

DALLAS FORT WORTH INTERNATIONAL AIRPORT

WAYFINDING SIGNAGE STANDARDS & GUIDELINES

Issue Date: 08.24.2017
Rev 1 Date: 09.30.2021



Prepared by: Labozan Associates

LOCHNER

1.0 DFW WAYFINDING OVERVIEW

1.1	Introduction	1-1
1.1.1	Overview	1-1
1.1.2	Wayfinding Philosophy	1-2
1.1.3	Wayfinding Evaluation Criteria	1-4
1.1.4	General Placement Guidelines	1-6
1.1.5	Wayfinding Application	1-7
1.1.6	Wayfinding Sign System Overview	1-9
1.1.7	General Graphic Standards	1-11
1.1.8	Wayfinding Sign Families	1-24
1.1.9	Governing Bodies, Codes & Regulations	1-34
1.1.10	Change Procedures/Sign Replacement	1-36
1.2	Wayfinding Analysis and Application	1-37
1.2.1	Overview	1-37
1.3	Design Criteria	1-38
1.3.1	Overview	1-38

2.0 WAYFINDING GRAPHIC STANDARDS & GUIDELINES

2.1	Messages	2-1
2.1.1	Overview & Functions	2-1
2.1.2	Message Hierarchy	2-1
2.1.3	Message Application	2-3
2.2	Typography	2-4
2.2.1	Overview	2-4
2.2.2	Type Spacing	2-5
2.2.3	Legibility	2-6
2.3	Symbols	2-7
2.3.1	Overview	2-7
2.3.2	Symbols List	2-8
2.4	Arrows	2-9
2.4.1	Overview	2-9
2.4.2	Arrow Application Guidelines	2-12
2.5	Colors	2-13
2.5.1	Overview	2-13
2.5.2	Color System	2-14
2.6	Art, Advertising and Amenities	2-15
2.6.1	Overview	2-15
2.7	Illumination	2-16
2.7.1	Overview	2-16
2.8	Wayfinding Sign System Overview	2-17
2.8.1	Overview	2-17
2.8.3	Sign Type Identification System	2-18

3.0 SIGN TYPES - TERMINALS/GATE AREAS

3.1	Sign Type Index	3-1
3.1.1	Overview	3-1
3.1.2	Terminals/Gate Areas	3-3
3.2	Sign Types	3-4
3.2.1	Directionals	3-4
3.2.2	Identification	3-19
3.2.3	Informational	3-32

4.0 SIGN TYPES - CURBSIDE/GROUND TRANSPORTATION AREAS

4.1	Sign Type Index	4-1
4.1.1	Overview	4-1
4.1.2	Curbside/Ground Transportation Areas	4-2
4.2	Sign Types	4-4
4.2.1	Directionals	4-4
4.2.2	Identification/Informational	4-12

5.0 SIGN TYPES - ROADWAY AREAS

5.1	Sign Type Index	5-1
5.1.1	Overview	5-1
5.1.2	Roadway Areas	5-2
5.2	Sign Types	5-4
5.2.1	Overhead	5-4
5.2.2	Roadside	5-8

6.0 SIGN TYPES - GARAGE/PARKING AREAS

6.1	Sign Type Index	6-1
6.1.1	Overview	6-1
6.1.2	Garage/Parking Areas: Pedestrian	6-3
6.1.3	Garage/Parking Areas: Vehicular	6-4
6.2	Sign Types	6-5
6.2.1	Directionals	6-5
6.2.2	Identification	6-31
6.2.3	Informational	6-38

7.0 TEMPORARY CONSTRUCTION SIGNAGE

7.1	Sign Type Index	7-1
7.1.1	Overview	7-1
7.2	Sign Types	7-1
7.2.1	Curbside	7-2
7.2.2	Roadway	7-1
7.2.3	Terminals	7-2

8.0 COVID PANDEMIC PREPAREDNESS SIGNAGE

8.1	Sign Type Index	8-1
8.1.1	Overview	8-1
8.2	Sign Types	8-1
8.2.1	Identifications	8-2
8.2.2	Detail Pages	8-2

9.0 AIRPORT BOUNDARY SIGN

9.1	Sign Types	9-1
9.2.1	Airport Perimeter Fence Signage	9-1
9.2.2	Trigg Lake No Trespassing Sign	9-2

10.0 APPENDIX : AHQ STANDARD

10.1	Sign Type Index	10-1
10.2	Graphic Elements	10-2

11.0 APPENDIX: BOARD FACILITIES

11.1	Sign Standards	11-1
------	----------------	------

WARNING:

This record contains Sensitive Security Information that is controlled under 49 CFR parts 15 and 1520. No part of this record may be disclosed to persons with a "need to know," as defined in 49 CFR parts 15 and 1520, except with the written permission of the Administrator of the Transportation Security Administration or the Secretary of Transportation. Unauthorized release may result in civil penalty or other action. For U.S. government agencies, public disclosure is governed by 5 U.S.C. 552 and 49 CFR parts 15 and 1520.

1.0

1.0 DFW WAYFINDING OVERVIEW

- 1.1 Introduction
- 1.2 Wayfinding Analysis and Application
- 1.3 Design Criteria
- 1.4 Wayfinding Factors and Planning

1.1 INTRODUCTION

1.1.1 OVERVIEW

Airports can be complex and difficult spaces to navigate. Numerous factors affect public perception and levels of customer service with the associated airport. This is particularly true when airport modifications or upgrade programs are undertaken. Older terminals, garages and roadways typically have outdated and inconsistent wayfinding signage systems not reflective of current world principals and standards, and improvement projects create even more challenges for individuals functioning within the airport's wayfinding processes.

It must be understood that regardless of an individual facility's demarcation, the wayfinding pathways extend to and from the surrounding roadways, parking, curbsides, terminals and concourse areas. Facility architecture, services, functions and amenities, as well as vertical and horizontal routes, must always be carefully considered and viewed as part of the airport's interconnected and overall wayfinding system. A solid understanding of graphic/visual cues and human behavioral responses to wayfinding processes is paramount, and the established wayfinding system must also function seamlessly, within the built environment, without user hesitation or confusion, regardless of what area of the airport is being navigated.

As an airport continues to evolve, it is important that it's wayfinding and signage systems be designed to accommodate these changes in a long-term holistic and adaptable manner. The primary focus should be on continual iteration and growth of the wayfinding system for the betterment of the airport's customer service experience rather than what's most convenient or pre-established. If an airport's existing wayfinding system has elements that function well, but could be improved upon to make the system function better for the majority of its users, enhancements should be considered and implemented.

BACKGROUND

DFW's terminals, curbsides, roadways and parking facilities are unique and complex entities that require wayfinding signage that is clear, consistent and comprehensive. Over many years, the use of differing wayfinding and signage applications/standards has resulted in a multi-layered signage system.

Additionally, over the next several years DFW will be going through major transformations due to multiple airport-wide improvement projects. Future improvement projects will also create continually changing wayfinding conditions.

Recognizing the complexity of their redevelopment plans, DFW commissioned the team of Labozan Associates, Inc. (LAI), Lochner and Moyer Consulting (referred to within this document as the Project Team) to provide wayfinding related data capture, analysis and evaluation of DFW's overall existing wayfinding signage program. During several stakeholder workshop meetings, the Project Team analyzed and presented several conceptual enhancement solutions that can establish a new holistic, refreshed and more effective DFW wayfinding signage system. This analysis identified potential discrepancies that may occur as a result of the Airport's redevelopment plans, as well as how enhancements to DFW's existing wayfinding system could address those issues holistically.

PROJECT GOALS

At the initiation of the project, several goals and objectives were introduced:

- DFW desires to be recognized as one of the best airports in the world, and sees wayfinding signage as a tool to achieve this recognition
- The Wayfinding Signage Observations and Recommendations will develop a vision and long-range plan for DFW's wayfinding signage system
- The Wayfinding Signage Observations and Recommendations will serve as a blueprint for addressing the wayfinding signage system as it relates to the overall growth of the Airport
- The project should yield a set of easy to understand guidelines for the holistic implementation of wayfinding signage to effectively communicate the Airport's basic philosophy and requirements with stakeholders, architects and designers to ensure the system is sustainable and maintainable
- The philosophies established in the Wayfinding Signage Observations and Recommendations will support the development of the updated Wayfinding Signage Standards and Guidelines

PURPOSE

This document presents information regarding the general development and planned implementation of DFW's new wayfinding signage system within all DFW airport property modernization programs. It will briefly establish recommendations for enhancement to all wayfinding signage being developed for the public accessible areas of DFW.

It should be noted that the current use of wayfinding signage and graphic standards at DFW is typically applied in a professional manner with varying degrees of success and consistency. However, it should also be noted that several enhancements could be made in several key areas to help make it more effective and more easily understood by a greater number of travelers.

SCOPE

The Wayfinding Signage Observations and Recommendations' scope includes the development of general philosophy, criteria and guidelines for the signage and wayfinding system Airport-wide, particularly for public use areas.

Topics covered within this document:

- Wayfinding Philosophy and Evaluation Criteria
- General Observations
- General Recommendations
- General Graphic Standards

Signs covered by this document:

- All interior and exterior wayfinding directional, identification and informational signs within public use areas only
- All on-airport roadway wayfinding signs within public use areas only
- All parking garage wayfinding signs within public use areas only

Signs not covered by this document:

- Tenant/concession/retail/advertising signs and standards
- Directory map artwork
- Flight Information Display Systems (FIDS)
- Baggage Information Display Systems (BIDS)
- Common Use Terminal Equipment (CUTE)
- Regulatory or life safety/egress signs
- Egress evacuation map artwork
- Branded Airline elements/systems/signs
- Rental car facilities/areas/signs
- Non-public, airside/runway/exterior or back-of-the-house areas/signs

DOCUMENT ORGANIZATION

This document is organized into six chapters:

1.0 DFW Wayfinding Overview

Purpose, background, scope of work, general requirements/design criteria and description of the DFW wayfinding system. Also includes general wayfinding factors and planning.

2.0 Wayfinding Graphic Standards & Guidelines

Specific graphic and design criteria/standards applicable to all DFW wayfinding signage:

- Message Standards - includes standardized message hierarchy for each category organized by sign type/message priority (primary, secondary and tertiary).
- Typography - includes descriptions for all wayfinding related typography.
- Symbol Standards - includes descriptions and list of all wayfinding related universal symbols.
- Arrow Standards - includes arrow standards, sizes, applications/meanings, rotation angles and placement.
- Color Standards - includes all color standards as applicable to the overall wayfinding system.
- Art, Amenities and Advertising - includes recommendations for addressing wayfinding signage in relation to art, amenity and advertising signage.
- Wayfinding Sign System Overview - includes general overview and recommended sign type identification system as applicable to the overall wayfinding system.

3.0 Sign Types - Terminals/Gate Areas

Overview, sign type index and design intent drawings for all wayfinding signage applicable to DFW's Terminals/Gates areas.

4.0 Sign Types - Curbside/Ground Transportation Areas

Overview, sign type index and design intent drawings for all wayfinding signage applicable to DFW's Curbside/Ground Transportation areas.

5.0 Sign Types - Roadway Areas

Overview, sign type index and design intent drawings for all wayfinding signage applicable to DFW's Roadway areas.

6.0 Sign Types - Garage/Parking Areas

Overview, sign type index and design intent drawings for all wayfinding signage applicable to DFW's Garage/Parking areas.

WARNING:

This record contains Sensitive Security Information that is controlled under 49 CFR parts 15 and 1520. No part of this record may be disclosed to persons with a "need to know," as defined in 49 CFR parts 15 and 1520, except with the written permission of the Administrator of the Transportation Security Administration or the Secretary of Transportation. Unauthorized release may result in civil penalty or other action. For U.S. government agencies, public disclosure is governed by 5 U.S.C. 552 and 49 CFR parts 15 and 1520.

1.1.2 WAYFINDING PHILOSOPHY

FOUNDATION AND BASICS

Wayfinding, as a process of increasing good customer service and well implemented design within built environments, has become an important consideration for companies and organizations of all sizes throughout the world. As a means of understanding the multifaceted topic of wayfinding as it applies to a large and complicated multimodal facility such as DFW, the following identifies several basics and foundations for good wayfinding:

What is ENVIRONMENTAL GRAPHIC DESIGN?

- The art of graphically presenting information or concepts to direct, influence or suggest a desired outcome, based on subjective and objective factors
- Is it an “Art” or a “Science?”...it’s actually a fusion of both

What is WAYFINDING?

- The processing of providing graphic direction and information to facilitate navigation through the built environment
- Enabling a journey: wayfinding, applied to Signage and Environmental Graphics, translates the process into logical and sequential units of information; a cognitive exercise in navigation

What is SIGN BRANDING/IDENTITY?

- Two or three dimensional presentation of a concept, relating to the desired essence and experience of product, service, facility or entity
- Establishing/reinforcing signage brand, helping to create a “sense of place”

The “VOICE OF THE OWNER”

- Wayfinding and Signage represents the “voice” of the owner, and should be assuring and calming
- Tonality can be passive/aggressive or positive/negative and should be considered in context of the surroundings

WAYFINDING ACCLIMATION

- Process of learning the wayfinding prompts and cues required for a journey (start to finish)
- Wayfinding must educate, creating user expectations for wayfinding to be provided

AUDIENCE

- Customer is #1; wayfinding should first and foremost accommodate the passenger and visitor

SIMPLICITY

- Less is really better
- Visual clutter can render wayfinding signage impotent & ineffective

LOCATION, PLACEMENT, FREQUENCY

- The right wayfinding element, at the right place, at the right time

- Horizontal/vertical: location, placement and frequency are critical

WAYFINDING CONSISTENCY

- For the entire pathway, wayfinding should be presented in a similar manner, perpendicular to circulation

STANDARDIZE

- Messages, fonts, colors, symbols, shapes, proportions, heights, placements, graphics, motif, branding and sub-branding

JOURNEY INCLUSIVE

- Intermodal / Multimodal: several methods of transportation can be taken to/from the airport, and within the airport (i.e. inter-terminal shuttles/trains)

SIGN & MESSAGE HIERARCHY

- Establish a sign type and message hierarchy ranking and stick to it

MESSAGING LIMITATIONS

- Only provide messaging and direction when absolutely necessary

MEMORABLE

- Only provide messaging and direction when absolutely necessary

KIT OF PARTS (sign family)

- Tool box/kit-of-parts, sign types and application for all wayfinding requirements, current and future (hanging, wall mount, etc.)

PROACTIVE/REACTIVE WAYFINDING

- Provide signage for 90% of the audience, not 10%, (consequences)

IT’S NOT ALWAYS A SIGN

- Enhance and augment wayfinding with art, flooring, landscaping, furniture, lighting, fixtures, advertising, architecture, etc.

HOLISTIC, 3D LANDSCAPE

- Consider and coordinate with art, advertising, retail, & advertising to create a more holistic visual landscape, “The Big Picture”

IT, FIDS/BIDS, WEBSITE, DYNAMIC SIGNS

- Critical component of the wayfinding, not a subset of IT

ADA and ACCESSIBILITY

- Controls font, size, contrast, placements, etc.
- Very beneficial, forces discipline

ALL ENCOMPASSING

- Wayfinding should be inclusive and considerate of various airport departments (i.e. retail/concessions, marketing, digital signage, parking, etc)

SIGNAGE PROGRAM ELEMENTS

In conjunction with a set of sound wayfinding foundation and basics, a successful wayfinding program should always include a basic set of documentation that is created and organized in the following manner:

Wayfinding Signage Standards and Guidelines

- Establishes visual consistency among the following elements:
 - Terminology and hierarchy of messages
 - Typography
 - Symbology
 - Arrows (style, placement and usage)
 - Colors
 - Materials
 - Illumination

Wayfinding Signage Observations and Recommendations

- Identifies wayfinding strategy and logic
- Provides holistic solutions on how to integrate and apply wayfinding into various airport facility zones or areas (i.e. terminal, curbside, ground transportation, parking, roadways, etc)
- It is the “why” behind the airport’s planned wayfinding solutions

Wayfinding Signage Design Intent Documents

- Provides details for fabrication and implementation within a specific wayfinding signage project
- Includes all sign types, design intent notes/specifications, detailed face layouts, general mounting detailing, intended sign usage and specific locations for it’s associated project and area of scope

Wayfinding Signage Implementation Plan

- Provides direction on how to apply the principles outlined in the Signage Standards and Guidelines and Observations and Recommendations
- Offers insight and/or scheduling on phasing and implementation priorities
- Provides the safest, shortest and simplest way to get from point A to B

WARNING:

This record contains Sensitive Security Information that is controlled under 49 CFR parts 15 and 1520. No part of this record may be disclosed to persons with a “need to know,” as defined in 49 CFR parts 15 and 1520, except with the written permission of the Administrator of the Transportation Security Administration or the Secretary of Transportation. Unauthorized release may result in civil penalty or other action. For U.S. government agencies, public disclosure is governed by 5 U.S.C. 552 and 49 CFR parts 15 and 1520.

DFW WAYFINDING SIGNAGE PHILOSOPHY

Develop ONE Signage System

Though there are varying facilities within the airport system that will be supported by signage, it must always maintain continuity throughout. Development of separate unassociated systems for each area (roadways, parking, terminals, gates) could dramatically alter the overall wayfinding. Additions, modifications and/or relocation of signs on the roads could have an impact on the wayfinding in the terminal. Therefore, developing and maintaining one cohesive, consistent and comprehensive system will enhance the travelers' decision-making process and perception of DFW as a whole.

Celebrate the Experience of Travel

Regardless of how common place air travel has become, the personal experience of leaving one's home, flying across the country, and arriving at a different destination is still an amazing event. Through decorative graphics, banner programs, wall graphics, sculpture, and thematic treatment of the signage elements whenever appropriate, celebrate that special travel experience and be supportive of all travelers, both local and foreign. Graphic enrichment programs should be supported by strong community and administrative policy thereby reflecting the values of the region and giving the traveler a taste of Dallas/Fort Worth.

Create an Identity for DFW

One of the most important aspects of the signage system is the opportunity it offers to establish an entirely new visual image for DFW. With a fresh, consistent, and dynamic visual image in place, the public will be encouraged to take another look at how to navigate at DFW. But the changes must be more than skin deep. Real communication improvements must be made, and the more significant the change, the more significant the awareness of it will be.

Design a System for Today and the Future

In an ever changing facility like DFW there is rarely, if ever, a good time to implement a major change-out of the signage program. Current uses often compete with future needs for available dollars. Good design practice requires stepping back, taking a hard look at the long term, and developing a series of scenarios, which serve both the near and long term. If planned properly, flexibility and fluidity of design will address most of the issues that arises.

DFW WAYFINDING DESIGN APPROACH

When designing wayfinding signage for implementation at DFW, three primary guidelines should be referenced and consistently followed during any conceptual, design and implementation phasing processes:

Signage Designed to Enhance the Passenger Experience

- The Passenger Experience is positive, enhanced by ease of wayfinding and promotes exploration of the Airport
- Eliminate visual clutter by concentrating and organizing messages into fewer and more deliberate signs
- Utilize appropriately sized graphics
- Display limited, succinct, and consistent nomenclature
- Use messages that are supported by universal symbols
- Adhere to ADA and add seamlessly into signage
- Signage should use widely accepted terminology, phrasing, and symbology
- Implement signage system Airport-wide, from the Roadways through the Parking facilities, and into and throughout the Terminal and Gates
- The sign system, facility design and operations should work in concert to facilitate easy-to-understand and easy-to-follow wayfinding
- Nomenclature, design styles, colors, typography, symbols and other design details should be appropriately consistent throughout all parts of the Airport
- The sign system should utilize a discreet family of sign types and maximize their use, while minimizing the use of non-standard sign types
- Focus on delivering the right message, in the right place, at the right time

Signage that Complements the Surrounding Environment

- Identify and reserve a color palette exclusive for signage, and apply this in a limited and controlled fashion
- Be harmonious with general interior and exterior architecture
- Visualize signage as an architectural enhancement, interesting and pleasing in form and graphics

Signage Designed to be Controllable and Manageable

- Integrate electronic application with implementation of new technologies and information sources
- Allow an appropriate level of variation commensurate with variations in designs of facilities
- The signage program should recognize the continuing evolution and expansion of the Airport
- It should provide credible and effective temporary signage
- It should provide design standards for future projects that can be effectively and efficiently applied by all design teams
- Encourage comprehensive coordination between multiple signage design teams for continuity
- The signage system should be maintainable over long-term time frames, and at a reasonable cost

WARNING:

This record contains Sensitive Security Information that is controlled under 49 CFR parts 15 and 1520. No part of this record may be disclosed to persons with a "need to know," as defined in 49 CFR parts 15 and 1520, except with the written permission of the Administrator of the Transportation Security Administration or the Secretary of Transportation. Unauthorized release may result in civil penalty or other action. For U.S. government agencies, public disclosure is governed by 5 U.S.C. 552 and 49 CFR parts 15 and 1520.

1.1.3 WAYFINDING EVALUATION CRITERIA

INTRODUCTION

While reviewing an existing wayfinding system, it is important to have a set of criteria from which to evaluate it. Wayfinding signs should always adhere to a basic set of guidelines that include several factors, including consistent copy styles/sizes, terminology, recognizable and universally accepted symbols, uniform colors systems, and recognizable sign types.

Prior to developing an updated Wayfinding Signage Observations and Recommendations, it was fundamental to understand the existing wayfinding signage at DFW. The Wayfinding Project Team analyzed all relevant existing materials by site visits, capturing photos, and reviewing existing and/or planned sign program documentation.

This section lists key elements that were used by the Wayfinding Project Team in evaluating the existing wayfinding system at DFW. For additional reference, wayfinding industry standard criteria and factors are also covered within the following documents:

- Guidelines for Airport Signing and Graphics - Terminal and Landside, Latest Edition
- ACRP Report 52 - Wayfinding and Signing Guidelines for Airport Terminals and Landside – Latest Edition
- Americans with Disabilities Act – 2010 ADA Standards for Accessible Design – Latest Revisions and Edition

The following are the specific evaluation criteria used for analyzing the existing DFW wayfinding program:

Wayfinding Signage Philosophy

- *Establish an integrated Framework that would produce ONE comprehensive signage system that can be easily understood, followed and identified*

In order to obtain the desired results from a sign system, a logical method of thinking must be employed by all parties involved in the process from the designers to the airport authority. Airport personnel, being familiar with the facilities will often forget that the traveling public is a captive audience in an unfamiliar environment. In addition, many designers will attempt to create unique sign systems by incorporating unique symbols, colors or decorative letter styles that reduce overall legibility of the message. Signage elements that compound the traveler's confusion will eventually lead to mistrust and disregard for the entire signage system.

This programming would stem from establishing one cohesive overall signage philosophy that encompass all areas of graphic communication (roadways, parking, curbsides, ground transportation, terminals, concourses etc.).

Standard Terminology

- *Experiencing the same terms and use of signs from one airport to the next will assist the general public in their comprehension and functioning within various airport facilities*

Message content must be in layman's language, understandable by the frequent and infrequent travelers.

The following terminology guidelines are consistent with typical standard primary messaging and terminology used at airports around the world:

- Airport Trailblazer and Airport Entrance(s)
 - Airport name (with its logo/or letter code)
- Airport Roadways
 - Terminal(s)
 - Departures
 - Arrivals
 - Ticketing/Check-In
 - Bag Claim
 - Parking
 - Rental Cars; Rental Car Return
 - Airport Exit
 - Return To Terminal(s)
- Terminal Building
 - Terminal
 - International Terminal
 - Domestic Terminal
 - Ticketing/Check-In

- Bag Claim
- Ground Transportation
- Parking
- Concourse(s)
- Gate(s)
- Toilets

In addition to the above listed terms, public service and regulatory terminology must also be standardized.

Message Hierarchy

- *Clear and concise information presented by "primary" and "secondary" signage system greatly improves the efficient passenger flow, both on the roadways and within terminal facilities*

A uniform hierarchy of messages and information needs to be established throughout the terminal and related facilities. Messages may be categorized into three levels: primary, secondary and tertiary.

1. Primary – Directional and Identification
 - Terminal
 - Ticketing/Check-In
 - Security Checkpoints
 - Bag Claim
 - Parking
 - Ground Transportation
 - Toilets
 - Gates
2. Secondary - Auxiliary services and support functions
 - Types of ground transportation
 - Flight Information Display Systems (FIDS)
 - Corporate identity (lounges, offices, and baggage services)
3. Tertiary - Third level information
 - Tenant names
 - Advertising
 - Regulatory / Safety and hazard related signs (emergency exits)

WARNING:

This record contains Sensitive Security Information that is controlled under 49 CFR parts 15 and 1520. No part of this record may be disclosed to persons with a "need to know," as defined in 49 CFR parts 15 and 1520, except with the written permission of the Administrator of the Transportation Security Administration or the Secretary of Transportation. Unauthorized release may result in civil penalty or other action. For U.S. government agencies, public disclosure is governed by 5 U.S.C. 552 and 49 CFR parts 15 and 1520.

Color Coding

- *Many studies have been done regarding colors and their effect on human behavior; therefore, careful study should be done when considering a multi-colored sign system*

It can clearly be recognized that many airports rely on basic brown, black or royal blue backgrounds with white lettering for both interior and exterior signing. While a few use the basic “highway” or Department of Transportation (DOT) green signs with white lettering, at other airports, there seems to be a need to explain the complexity of the facility by the use of a multi-colored sign system.

Many problems occur with multicolored sign systems, particularly with complex facilities and garage structures. Approximately 12 percent of the population is color blind, and these people cannot distinguish between mixed shades of red and orange, yellow or brown, black and blue. For this reason, if multiple colors are used it may be necessary to spell out the name of the color on the sign to make it clear to many of these individuals. It should also be noted that light affects color systems, and many colors fade and tend to blend in certain regions of the country due to weather conditions; therefore the use of color should be partially evaluated based on the geographic location of the airport.

Finally, it is also important to note that many studies have been done regarding colors and their effects on human behavior. These documents go into great detail and supply a host of alternatives. Therefore, it would be important that careful study be done when considering a multicolored sign system.

Symbols

- *The use of short verbal messages along with symbols is more effective than the use of messages or symbols alone*
- *The orientation and directional information that arrow symbols intend to convey is of equal importance to the consistent use of the recommended single style arrow*

The American Institute of Graphic Arts (AIGA), under contract to the US Department of Transportation, have developed a series of universal symbols in an effort to provide the public with recognizable characters. Today there are a multitude of recognizable symbols available and additional symbols are being developed from time to time. The following are a few guidelines in the use of symbols at airports:

- Mixing messages and symbols for relatively minor or secondary terminal functions, activities or tenants with essential public messages and main directional information, weakens the overall communications of the entire system
- Too many symbols or arrows at any one location can be counterproductive to the information being provided

The arrow orientation to convey “straight ahead” is of particular interest. Once a method has been selected for the “straight ahead” arrow orientation, consistent application should be continued throughout the signage system.

Scale of Copy

- *In a fast paced, often congested environment such as an airport, use a more conservative viewing distance such as 25 feet of viewing distance to each inch of cap letter height*
- *Airport roadway systems typically do not provide the lead time and distance between signs to comply with DOT guideline; therefore, a careful evaluation of what works, based on logical messages and reasonable copy heights, is very important*

Various studies by multiple agencies, authorities and universities have been done with regards to copy size and legibility. Through those studies, practical viewing distances (for a one-inch capital letter) have ranged from 16 to 50 feet, however, the most accepted viewing distance in the industry is 50 feet for a one-inch cap height, under optimal conditions by someone with 20/20 vision.

The relationship between capital letter height and lowercase letter height should be from 1:0.67 to 1:0.75 in order to allow lowercase to be read when smaller cap heights are used. Upper and lower case letters with medium stroke width are recommended for better legibility, since words composed of all capitals are much harder to read.

Many airport departments insist that the standard state and federal guidelines for roadway signage be followed. Although this is logical, in many situations, it is sometimes impossible to achieve.

Placement

- *Placement of signs at key decision points and/or in the direct line of sight of the traveling public reduces decision times*

Proper location of signs can dramatically alter the effectiveness of a signage system. This keeps pedestrian and vehicular traffic constantly moving, which is the objective of a comprehensive and effective system.

Sign placement should occur at all decision points and at those places where people become disoriented by the architectural configuration. In addition to directional signs being placed at every decision point, they should also be placed at reassuring intervals within a captive corridor. The architecture or competing pedestrian traffic flow may imply a change in direction; therefore signs may be required to reinforce the intended direction. A reasonable range of 75 to 125 feet between major directional overhead signs is acceptable and meets the general intent of ADA (Americans With Disabilities Act guidelines) and Texas Accessibility Standards.

A general rule for selecting sign placement is for the designer to put himself in the position of a departing or arriving passenger, visitor, or accompanying passengers throughout the terminal. These guidelines are general in context and some disorienting conditions that may require additional signing are:

- Complex architecture
- Competing pedestrian traffic
- Visual distractions
- Congested corridors

Conversely, favorable conditions that may reduce repetitive signage are:

- Efficient architecture
- Single direction traffic flow
- Minimal pedestrian usage
- Wall or floor treatments reinforcing single-direction traffic flow
- Lighting treatments emphasizing concourse hallways or other destinations

WARNING:

This record contains Sensitive Security Information that is controlled under 49 CFR parts 15 and 1520. No part of this record may be disclosed to persons with a "need to know," as defined in 49 CFR parts 15 and 1520, except with the written permission of the Administrator of the Transportation Security Administration or the Secretary of Transportation. Unauthorized release may result in civil penalty or other action. For U.S. government agencies, public disclosure is governed by 5 U.S.C. 552 and 49 CFR parts 15 and 1520.

1.1.4 GENERAL PLACEMENT GUIDELINES

Airports typically have several elements and systems that compete with pedestrian wayfinding signage. These include (but may not be limited to) art, advertising and amenity related signage. Consistent and sensible location of wayfinding signage in relation to each of these elements will ensure an effective and positive wayfinding experience. This section provides general guidelines and recommendations for effective placement of wayfinding signage in relation to these other nearby elements.

DFW "Wayfinding Signage Philosophies" place a priority on ease of wayfinding throughout all of its facilities. As a result, the DFW wayfinding system will typically take visibility and placement priority over other nearby systems such as art, advertising and amenity elements. However, it must also maintain general harmony with regards to visibility and general placement in relation to these other nearby systems. The following general guidelines have been established and should be used by all designers specifying wayfinding signage within DFW airport facilities.

Placement of wayfinding signage in relation to art, advertising and amenity elements shall always be done so in a manner that maximizes the visibility of each without obstructing important wayfinding information. As such, a simple grid system should be used by designers to maximize the placement of each element. This grid system is based on a simple X/Y/Z axis system (i.e. X = horizontal axis; Y = vertical axis; Z = third-dimension axis, or "forward/backward" in relation to the viewer's position).

The following are general guidelines to be used as a reference for placing wayfinding signage in relation to art, advertising and amenity elements (see Figure 1.1.4):

- Typical Vertical Placement:
 - Vertical placement of wayfinding signage and nearby elements will use an established set of three-dimensional spatial zones along the Y-axis plane and extend forward/backward along the Z-axis plane
- Typical Horizontal Placement:
 - Horizontal placement of wayfinding signage and nearby elements will use an established set of three-dimensional spatial zones along the X-axis plane and extend forward/backward along the Z-axis plane

Signage Zones

Basic placement zones have been provided here for locating DFW wayfinding signage in relation to art, advertising and amenity related elements (see Figure 1.1.4). The following general guidelines should be utilized when locating wayfinding signage near these elements (Note: A.F.F. = "above finished floor"):

- Overhead Wayfinding Zone: is a +/- 3'-0" high three-dimensional spatial plane dedicated to placement of overhead pedestrian wayfinding signage
 - Typical vertical zone size = +/- 8'-6" A.F.F. to 11'-6" A.F.F.
 - Note that the zone may also extend above or below these dimensions if deemed appropriate for a given location's conditions and requirements

- The line-of-sight for this zone should always maintain an unobstructed view of 50'-0" minimum on the Z-axis plane approach
- Amenity Zone: is a +/- 2'-6" high three-dimensional spatial plane that applies to placement of signage and/or elements for amenities (i.e. restaurants, taverns, retail shops, concessions, etc.)
 - Typical vertical zone size = +/- 6'-8" A.F.F. to 8'-6" A.F.F.
 - Placement of amenity elements within this zone are dependent upon established DFW amenity signage design standards and per individual terminal facility conditions; wayfinding signage should typically maintain a +/- 10'-0" min. horizontal perimeter away from amenity signage/elements whenever possible
- Lower Wayfinding/Art & Advertising Zone: is a +/- 6'-8" high three-dimensional spatial plane that applies to placement of lower wayfinding signage (i.e., floor mounted and lower wall mounted sign types), as well as concessions, art and advertising elements typically scaled for more personal interaction/viewing
 - Typical vertical zone size = Finished Floor to +/- 6'-8" A.F.F.
 - Art, advertising and freestanding concession elements in this area

should typically maintain a horizontal perimeter of +/- 10'-0" min. from wayfinding elements whenever possible

- Overhead Art & Advertising Zone: Note that overhead art & advertising requires flexibility in sizing and spacing and is preferred to occur above the Overhead Wayfinding Zone whenever possible (typically above 11'-6" A.F.F. or as deemed appropriate for a given location's conditions or sizing requirements, and is dependent on individual terminal facility conditions)

NOTE: Dimensions shown here are to be used as a general guideline only; some overlap of zones is to be expected and may occur depending on unique terminal environment conditions and sizing of wayfinding signage and existing/planned art, advertising and amenity elements; designers are required to review all wayfinding signage in relation to art, advertising and amenity elements as location conditions require, and adjust placements as necessary.

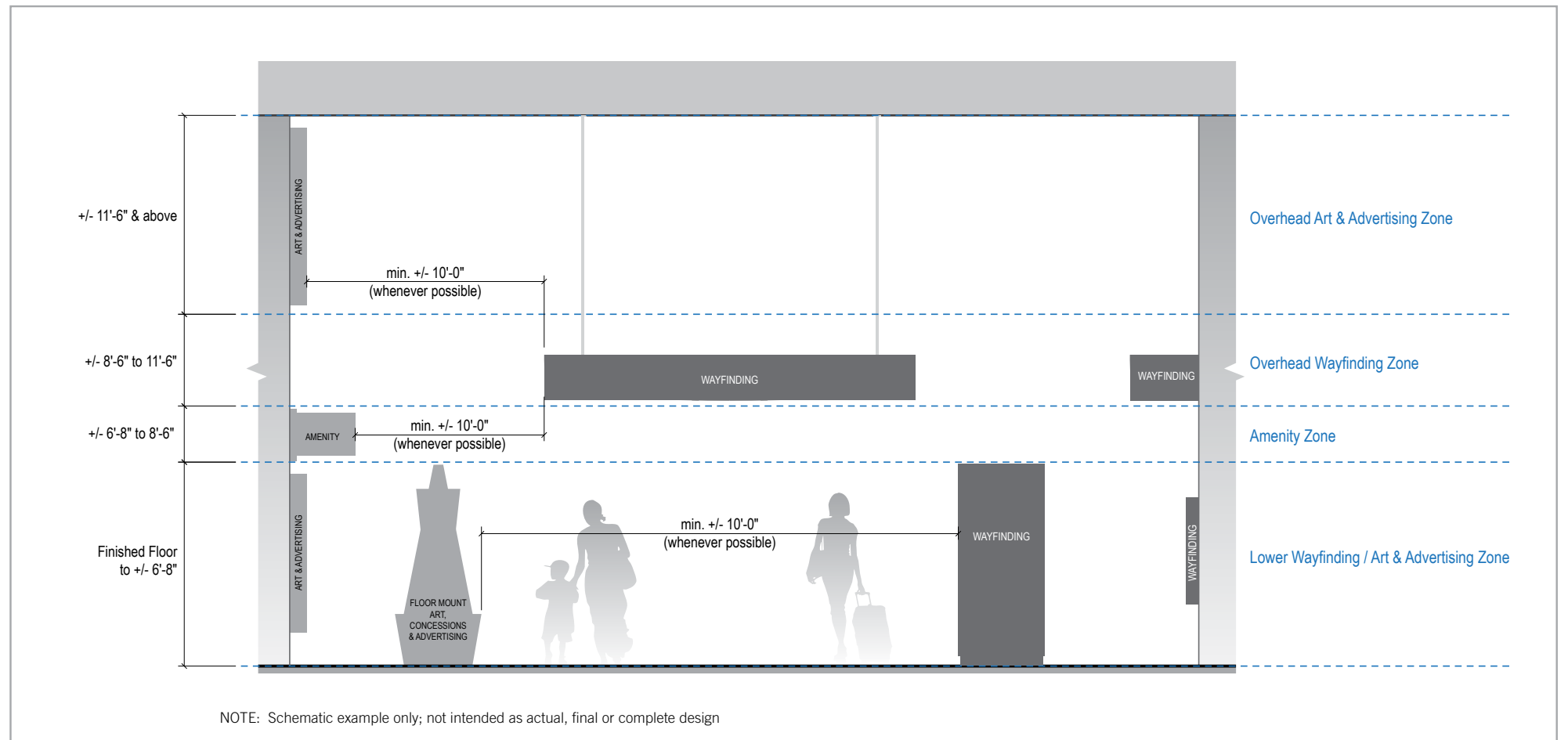

Figure 1.1.4 Typical Signage Zones - Recommended

1.1.5 WAYFINDING APPLICATION

GENERAL WAYFINDING FACTORS AND PLANNING

The ability to orient and navigate one's way through the varying environments as found within DFW airport facilities is of fundamental importance. Wayfinding planning using graphic diagrams establishes the analysis of spatial relationships and traffic circulation. All designers should utilize similar planning processes as shown here when designing signage for use at DFW.

Wayfinding Planning: Circulation Analysis

During design development, incoming and outgoing circulation for major user groups (i.e., pedestrians, vehicular, etc.) should be analyzed and documented by the designer. Points of origin and destination should be referenced as the basis for identifying critical decision points and message/information/signage requirements.

Primary user circulation routes should be depicted as solid-lines with end arrows, pointing in the direction of the individual traffic flow. Dotted lines with end-arrows depict possible alternate circulation routes occurring at direction changes (see Figure 1.1.5a).

Wayfinding Planning: Identification of Decision Points

Decision points along user circulation routes should be located at required direction changes, and points where the user encounters alternative choices. Decision point locations should be shown as larger yellow dotted-line circles at primary traffic-change intersections; in addition, areas where reinforcement is needed (i.e., longer corridors without a change in traffic direction) should be indicated by smaller yellow dotted-line circles (see Figure 1.1.5a). These areas are the most optimal location for placing directional signs that inform the user of the nearest existing and alternative wayfinding pathways for consideration.

Determining Required Information at Decision Points

Upon review of an area's wayfinding conditions, the required messaging/information and signage needed for a given decision point should be determined by the designer using logical thinking and the established standards in this document. The selection of messages identifying wayfinding destinations, as well as the selection of proper sign types should be determined by using the established DFW wayfinding message hierarchy, arrows, universal symbols and wayfinding sign types as listed in this document. In the event that custom wayfinding messaging or signage conditions occur, the designer should document/coordinate the recommendations with DFW for review and approval.

Identification of Sign Locations - Recommended

Plans, cross sections and elevation views of related project facility/site spaces should be analyzed by the designer to make determinations of sign locations. Following review of the architectural/environmental/site conditions, scaled plans should be generated with sign location "bars" (i.e., plan/top view representational boxes indicating the sign's basic size/shape that are scaled to match the floor plan, and are oriented/rotated as the sign would be in "real world" conditions). Differing and/or multiple sides of each sign should be indicated with a unique alpha designation (such as A, B, etc.) per sign location, and should coincide precisely with the specific sign type and related sign message schedule. Note that *all* signs should be given a *unique* sign location

annotation box, and will always be accompanied with a leader line extending from each annotation box to its associated sign location bar.

Also note that all overhead sign locations should be coordinated with architectural reflected ceiling plans (RCP) to ensure that no interferences occur with established and/or new architectural/environmental elements. Sign locations should be located in sensible areas nearest to its associated decision point, and in conjunction with existing or planned facility/site structural support elements whenever possible.

Sign Location Annotation - Recommended

The DFW sign location annotation system recommended in this document should be used to identify sign locations on all DFW wayfinding signage related documentation. Within terminal facility related areas (i.e., terminals, concourses, CBP areas, curbside/ground transportation areas and parking garages), each sign should be given a designation of location as shown on the following page in Figure 1.1.5b. Within airport property roadway areas (i.e., roads within the "Terminal Loop" zone near terminal facilities and perimeter roadways circulating around the airport's property), each sign should be given a designation of location as recommended on the following page in Figure 1.1.5c.

Message Schedules

All DFW Airport wayfinding signage related projects should include a message schedule, preferably in a graphic format showing examples of actual scaled sign face artwork. Message schedules should always coincide with, and precisely match, their corresponding sign location plan(s), and should account for every sign that is a part of the associated signage project. It should always include (at a minimum) the following elements/information:

- Unique Sign Location Number (i.e., "TA.L2-001," etc.)
- Sign Type Identification Number (i.e., "1.ID-35," etc.)
- General description of the sign type (i.e., "Wall Mount Overhead Restroom Entry ID," etc.)
- Side listings (i.e., "Side A," "Side B," etc.)
- Messages shown per side (i.e., graphic depiction of the actual sign face artwork, per each individual sign face side)
- Remarks/Notes (if needed for description of special circumstances, etc.)

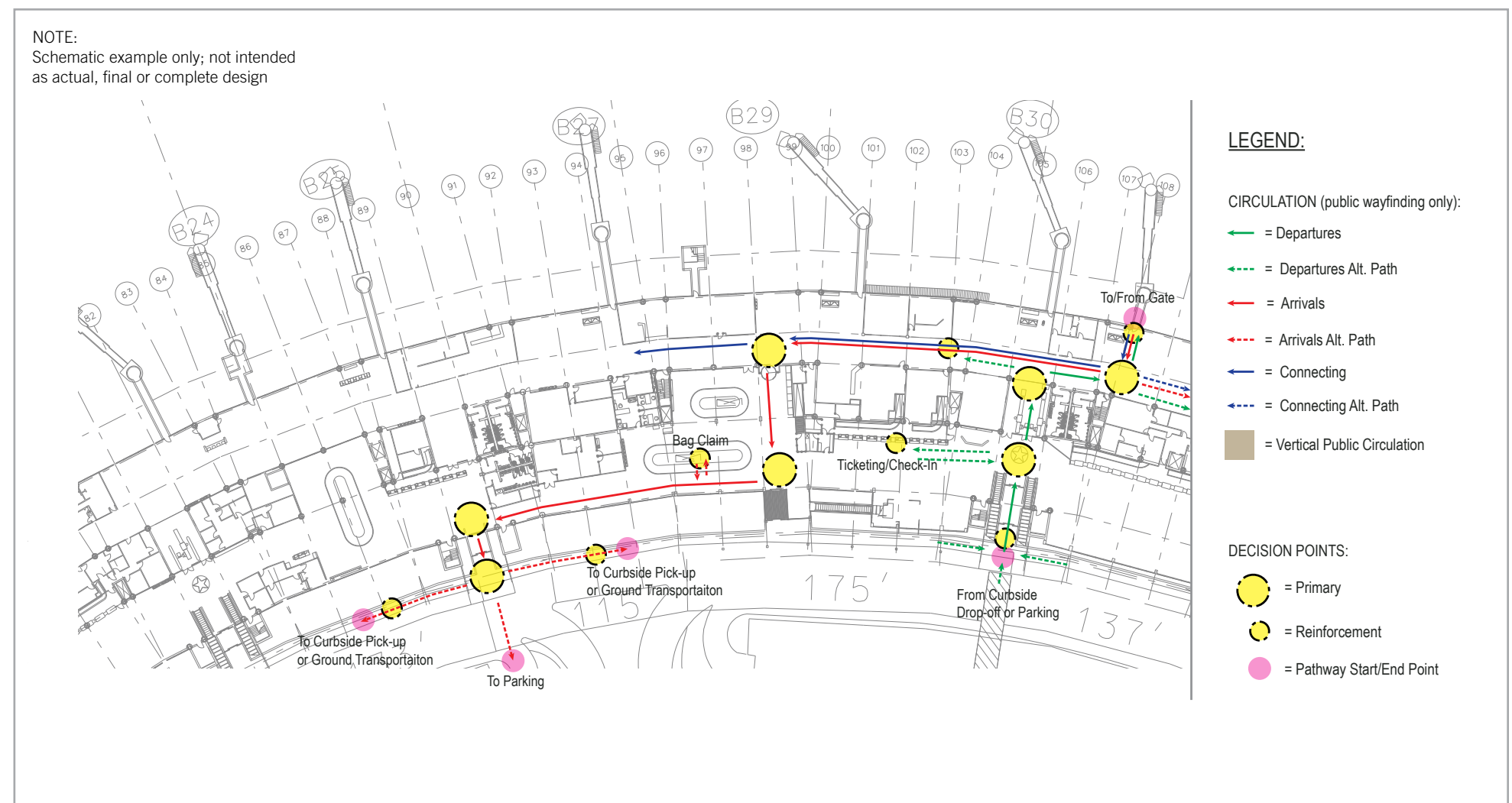

Figure 1.1.5a

Typical Wayfinding Plan Example

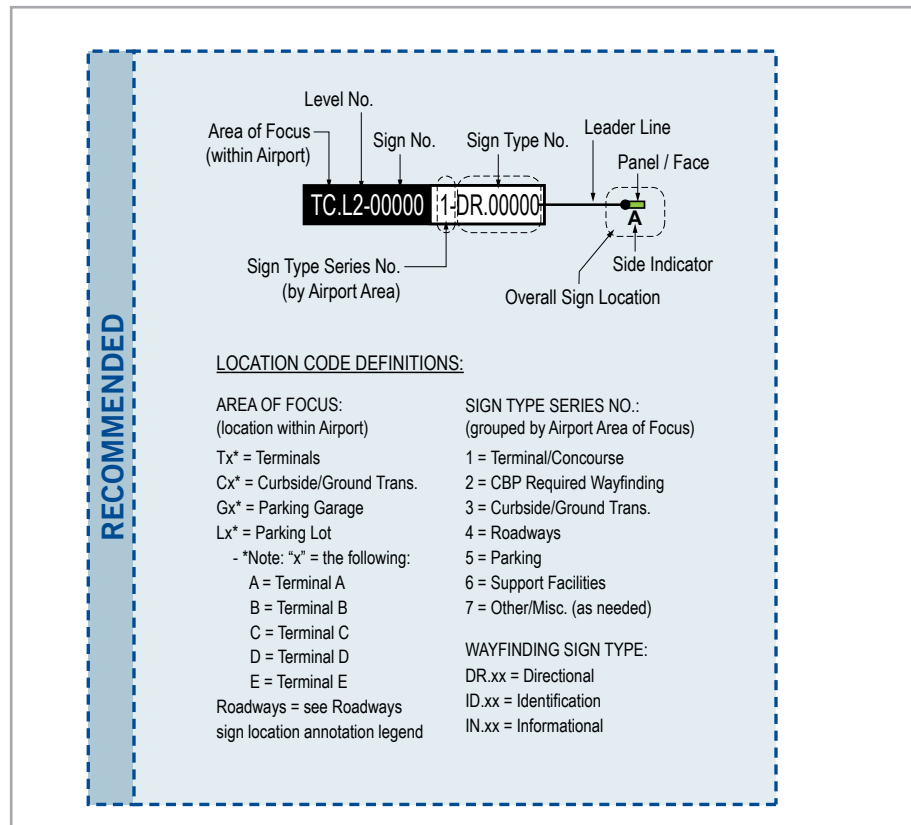

Figure 1.1.5b Sign Location Annotation - Terminal Facility Areas

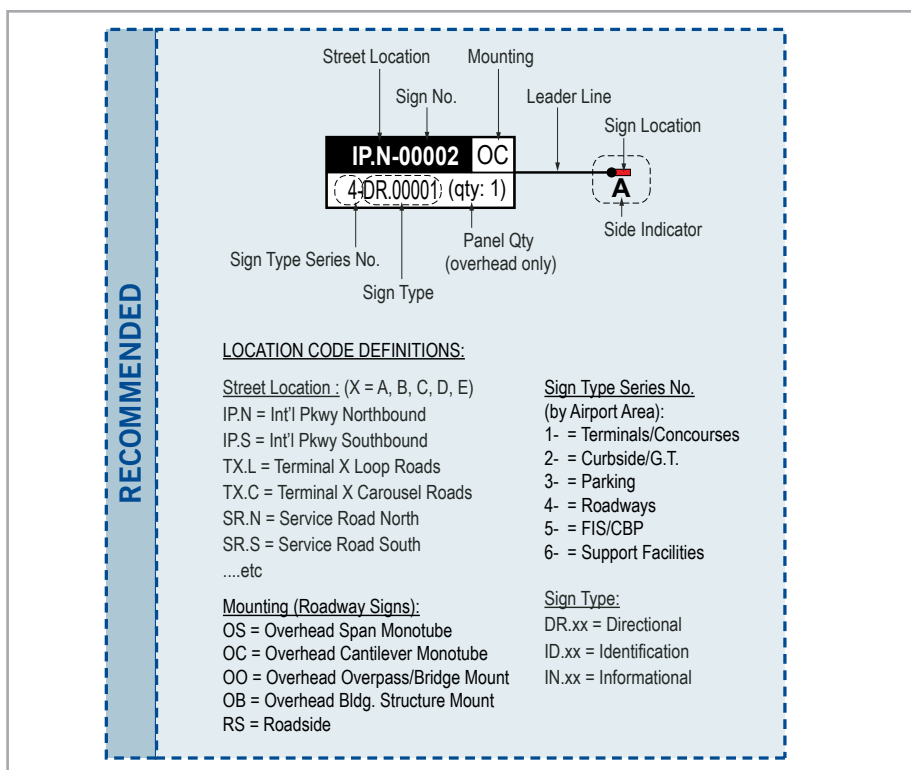

Figure 1.1.5c Sign Location Annotation - Roadway Areas

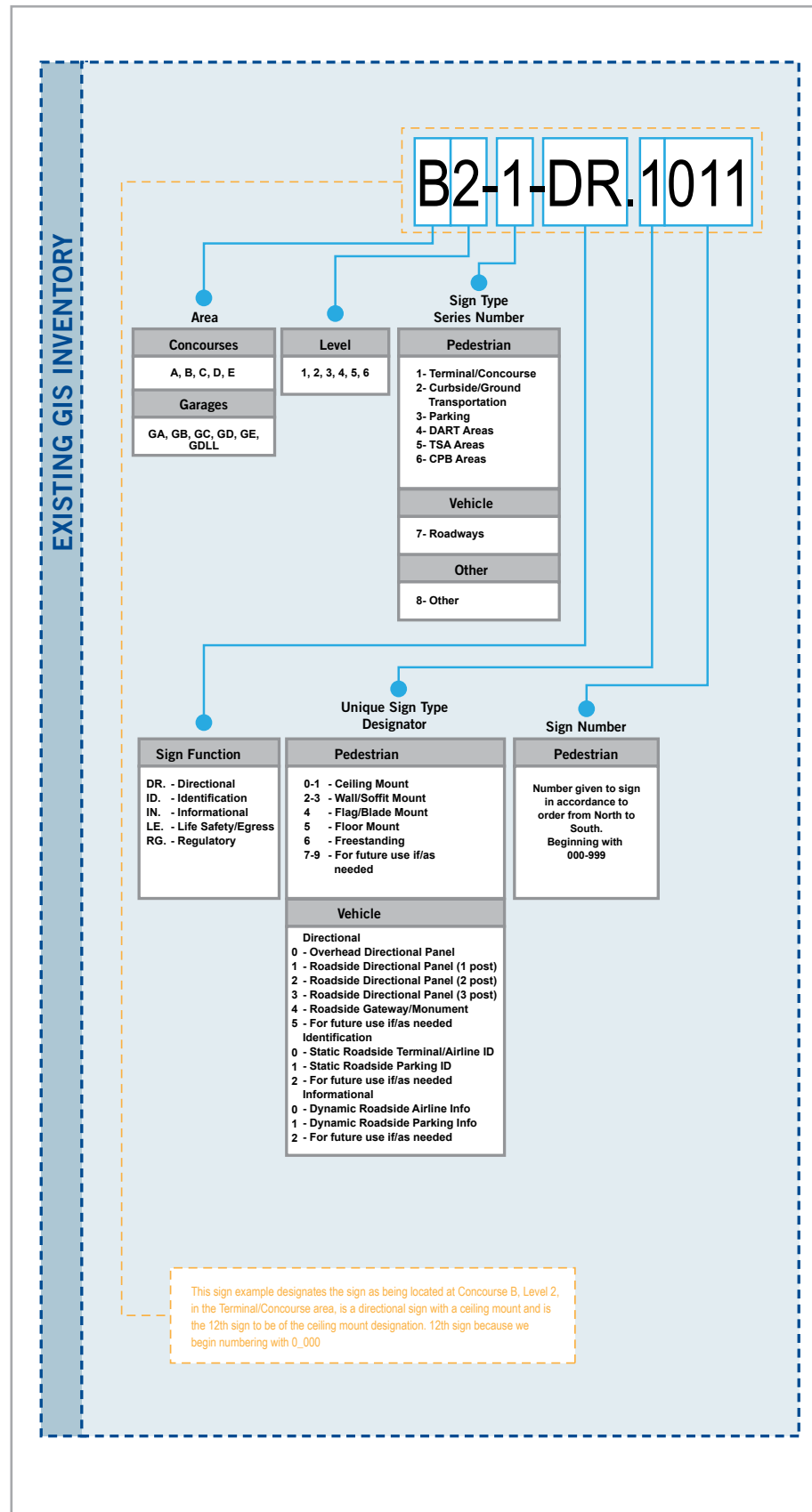

Figure 1.1.5d Sign Location Annotation - Existing GIS inventory

GENERAL SIGN PLACEMENT

Viewer circulation patterns and natural lines of vision are the basis for determining the location of all wayfinding signs. Signs should be located to precede decision points whenever possible. This will ensure sufficient time for users to react to each sign's set of messaging/information.

Sign Placement Considerations - Pedestrian Signage

A general rule for placing wayfinding signage is that a designer visualize themselves as an average departing or arriving passenger within a given airport environment, while thinking logically about decision points and the required messaging expected at a specific location. This guideline is very general in context, however, the requirements of the given sign location will be very specific regarding messaging, sign type and usage.

Note that disorienting conditions may occur, which in turn may require placement of additional or supplemental signage. These typically include:

- Complex architecture/interior environments
- Competing pedestrian wayfinding traffic
- Visual environmental distractions
- Congested architectural spaces/corridors

Favorable conditions which typically reduce need for repetitive signage are:

- Efficient architecture/interior environments
- Single direction wayfinding traffic flow
- Wall or floor treatments reinforcing single-direction traffic flow
- Lighting treatments emphasizing architectural passageways

Sign Placement by Sign Type - Pedestrian Signage

- Directional signs - placement will be perpendicular to wayfinding traffic, and will occur at all decision points and areas where people become disoriented by architectural or environmental conditions. Directional signs will also be placed at reassuring intervals within a captive corridor to reinforce directional messaging to wayfinding traffic. Note that architectural/interior conditions or competing pedestrian traffic flow may also inadvertently imply a change of direction. In these situations, additional directional signs will be used to reinforce the intended direction as needed
- Identification signs - placement will typically occur at or near all priority destinations and entrances. Identification signs, such as gate ID signs or corridor/building entrances, will also typically be placed perpendicular to wayfinding traffic
- Informational signs - placement will typically be located nearest major decision points. Directories will typically be located to the side of a major decision point and will be parallel/in-line with wayfinding traffic. FIDS and other dynamic informational systems should also be typically located parallel/in-line with wayfinding traffic unless otherwise deemed beneficial to be perpendicular in a given situation

Typical Pedestrian Sign Placement Intervals - Best Practices

Placement of signs at key decision points and/or in the direct line of sight of the traveling public reduces decision times. A reasonable range of 75 to 125 feet between major directional overhead signs is typical and meets the general intent of ADA guidelines. Using signs at regular intervals in longer captive corridors reinforces wayfinding information and improves traffic flow.

Sign Placement Considerations - Vehicular Signage

Note that disorienting conditions may occur due to the complex nature of airport roadway systems, which in turn may require placement of additional or supplemental signage. These typically include:

- Complex roadway/roadside/site or construction related conditions
- Competing vehicular wayfinding traffic
- Visual environmental distractions
- Congested traffic conditions

Favorable conditions which typically reduce need for repetitive signage are:

- Efficient/simplified roadway/roadside/site conditions
- Efficient sight lines for drivers of varying driving abilities
- Gradual road curves and exit lanes with adequate length
- Signs located with adequate distance and sizing to queue traffic safely and efficiently at posted speed limits

Sign Placement by Sign Type - Vehicular Signage

- Directional signs - placement will be perpendicular to wayfinding traffic, and will occur at all decision points and areas where drivers become disoriented by roadway or environmental site conditions. Directional signs will also be placed at reassuring intervals to reinforce directional messaging to wayfinding traffic. Note that roadway configurations/conditions or competing vehicular traffic flow may also inadvertently imply a change of direction. In these situations, additional directional signs should be used to reinforce the intended direction as needed per MUTCD/TXDOT requirements
- Identification signs - placement will typically occur at or near all priority destinations and roadway entrances. Identification signs (such as Airline ID signs), will also typically be placed perpendicular to wayfinding traffic
- Informational signs - placement will typically be located nearest major decision points. Informational signs will be perpendicular to wayfinding traffic, and will typically be located prior to major decision points and/or near entrances to the corresponding area

Typical Vehicular Sign Placement Intervals - Best Practices

- Placement of signs at/near key decision points and/or in the direct line of sight of the drivers reduces decision times
- For vehicular traffic, signs should generally be placed at intervals as deemed appropriate for the given condition. The specific distance used will typically depend on the legibility of the vertical height of the lettering at the posted speed limit. NOTE: all MUTCD/TXDOT requirements must always be followed

1.1.6 WAYFINDING SIGN SYSTEM OVERVIEW

The wayfinding sign system shown in this document represents a generally holistic system being implemented throughout all DFW facilities. The DFW wayfinding sign system should always be consistent in appearance and application throughout the entire airport area in which it is being applied. Doing so consistently will establish a public perception that DFW is a professional and forward-thinking organization, which will always be apparent within any of its amenities or facilities.

Design Description – DFW Wayfinding Signage System

The DFW wayfinding signage system should continue to be developed to make all airport wayfinding signage an extension of DFW's world-class branding and philosophies. It should meet the established principles of DFW's general mission and vision for wayfinding. The following should be universally adopted at all DFW facilities:

- Provides safe, efficient and appealing wayfinding at all DFW Airport facilities
- Reinforces DFW as an airport standard of excellence within the United States, as well as the world
- Unifies signage as one holistic wayfinding system, both interior and exterior
- Shares a consistent, positive “tone-of-voice” at all DFW areas and facilities
- Creates a consistent and shared “sense of arrival” and a “sense of place” at each Airport area and facility

These same principles will always be used for all wayfinding signage implemented within any of DFW's modernization programs.

Sign System Objective: Pedestrian Signage

The general objective of the Pedestrian related wayfinding sign system should be to direct the flow of pedestrian traveler traffic at curbside/ground transportation areas, in and out of the public terminal entrances, between appropriate designated terminal areas, in/out of the concourse/gate holdroom or CBP passenger processing areas, and within pedestrian related areas of parking garage facilities. This is achieved by using a hierarchy of signage that relates specifically to pedestrian traffic, and should be designed with appropriately sized graphics, visual queuing elements, orientation and placement for such traffic.

Sign System Objective: Vehicular Signage

The general objective of the Vehicular wayfinding sign system should be to direct the flow of vehicular traffic in and out of DFW, as well as throughout its various public-use facilities (i.e. to/from parking facilities, terminal curbs, service areas, etc.). This is achieved by using a hierarchy of signage that relates specifically to vehicular traffic, and should be designed with appropriately sized graphics, visual elements/features, orientation and placement for such traffic.

Special Areas

Some areas of the DFW airport properties do not necessarily fall within a specific category, and as such are identified as special areas. A special area should be specifically designed for and reviewed/approved by DFW on a case by case basis as needs require. Examples of special areas may include (but are not limited to) public art, advertising and concession related signage.

Interim (Temporary) Signage

Sign types developed for temporary/interim conditions shall also use the standards and guidelines for permanent wayfinding signage as shown in this document as a baseline for matching the rest of the wayfinding system.

Exceptions

To be successful, a signage program must allow for flexibility. Exceptions to any of the general signage standards and guidelines listed within this document should be reviewed on a case-by-case basis, and enforced by DFW as deemed necessary and appropriate.

SIGN TYPES – GENERAL OVERVIEW

There are several elements that make up a clear and recognizable sign. Even though the message and its copy size/clarity are of great importance, so too is the actual sign entity that it is placed on. Having consistent and distinct sign types enhances a sign system by being more recognizable to its users within unfamiliar environments. Many travelers can decipher the type of information that will be given based on the size, shape, mounting location or color of the sign. This shortens the decision-making process, creating smoother traffic flow and increased trust in the overall wayfinding system.

Sign types will typically be used based on their message priority and basic function:

- Primary Signs Types: Signs used for priority destinations/functions of the airport are considered “Primary” signage, and should be the most visible and visually dominate to other wayfinding signage
- Secondary Sign Types: Secondary messaging (such as Telephones, ATM, etc.) should typically be reserved for sign types pre-determined as “Secondary” in nature, and should appear visually subordinate to the Primary signage
- Tertiary Sign Types: Tertiary messaging (such as regulatory, safety related information, etc.) should also be placed on sign types pre-determined for “Tertiary” use, and should appear visually subordinate to both Primary and Secondary signage

Wayfinding Sign Family

DFW's wayfinding system should use a comprehensive sign typing system that is based on categories of a sign's function. In some regards it has been developed into a holistic family of signs with each member having their own specific use and purpose, while also utilizing a “kit-of-parts” design philosophy. It should be designed as manageable, and allow for being seamlessly integrated within all DFW facilities, while being updated on a continuing basis as needs arise.

Wayfinding sign types at DFW airport facilities should be classified as directional, identification, informational, regulatory, life-safety/egress and interim (temporary). Major sign type classifications (as categorized by function) and general descriptions of each should include:

- Directional: Signs that display standardized directional messaging to assist in finding one's way through a defined area or environment (i.e., an overhead sign at a decision point with arrow/symbol/destination messages listed)

WARNING:

This record contains Sensitive Security Information that is controlled under 49 CFR parts 15 and 1520. No part of this record may be disclosed to persons with a "need to know," as defined in 49 CFR parts 15 and 1520, except with the written permission of the Administrator of the Transportation Security Administration or the Secretary of Transportation. Unauthorized release may result in civil penalty or other action. For U.S. government agencies, public disclosure is governed by 5 U.S.C. 552 and 49 CFR parts 15 and 1520.

- Identification: Signs used as unique markers to identify specific locations within a defined area or environment (i.e. a gate identification sign).
- Informational: Signs or graphic systems that display specific and very detailed information to assist in orientation within a complex or unfamiliar environment (i.e. a directory map or FIDS)
- Regulatory: Signs that display regulatory information (i.e. “No Parking” or “Loading Zone Only” signs)
 - Note: not included as part of this document
- Life-Safety/Egress: Signs that display life-safety and vertical circulation/ egress related information as required by local and national codes (i.e. fire escape stairway core level identification signs)
 - Note: not included as part of this document
- Interim (Temporary): Signs that can be directional, identification, informational and regulatory, but are made of temporary materials and mounting methods
 - Note: not included as part of this document

The following wayfinding sign families are included within this document (see Section 3.5 Wayfinding Sign Families, sub-sections 1.1.8):

- Terminals/Gate Areas (Figure 1.1.8a)
- Curbside/Ground Transportation Areas (Figure 1.1.8c)
- Garages/Parking Areas (Pedestrian: Figure 1.1.8d; Vehicular: Figure 1.1.8e)
- Roadway Areas (Figure 1.1.8f)

Note: All sign types shown in this document are intended as general design intent only; Sizes shown are typical only; terminal conditions vary and may require adjustment for final design of sign type sizing/proportions/etc.; additional sign types not shown in this document may be required as determined during design processes of individual DFW improvement programs.

Scale and Sizing

Scale and sizing for all DFW wayfinding signage will be consistent and designed to the appropriate required viewing distances for a given condition or environment, as well as to the minimum ADA and/or MUTCD/TXDOT requirements.

Note: Sign types shown are for typical conditions only and are designed to accommodate minimum ADA and MUTCD/TXDOT requirements (i.e., minimum 3” capital height letters on pedestrian overhead signs at approximately +/- 8'-0” above finished floor to bottom of sign). Adjustments to the scale and size of certain sign types may be necessary to maximize visibility and aesthetic harmony within a given wayfinding condition or environment during design development. As such, all designers specifying wayfinding signage for use at DFW will review all individual spatial and environmental conditions per each modernization program, and make recommendations for scale/size adjustment as deemed appropriate.

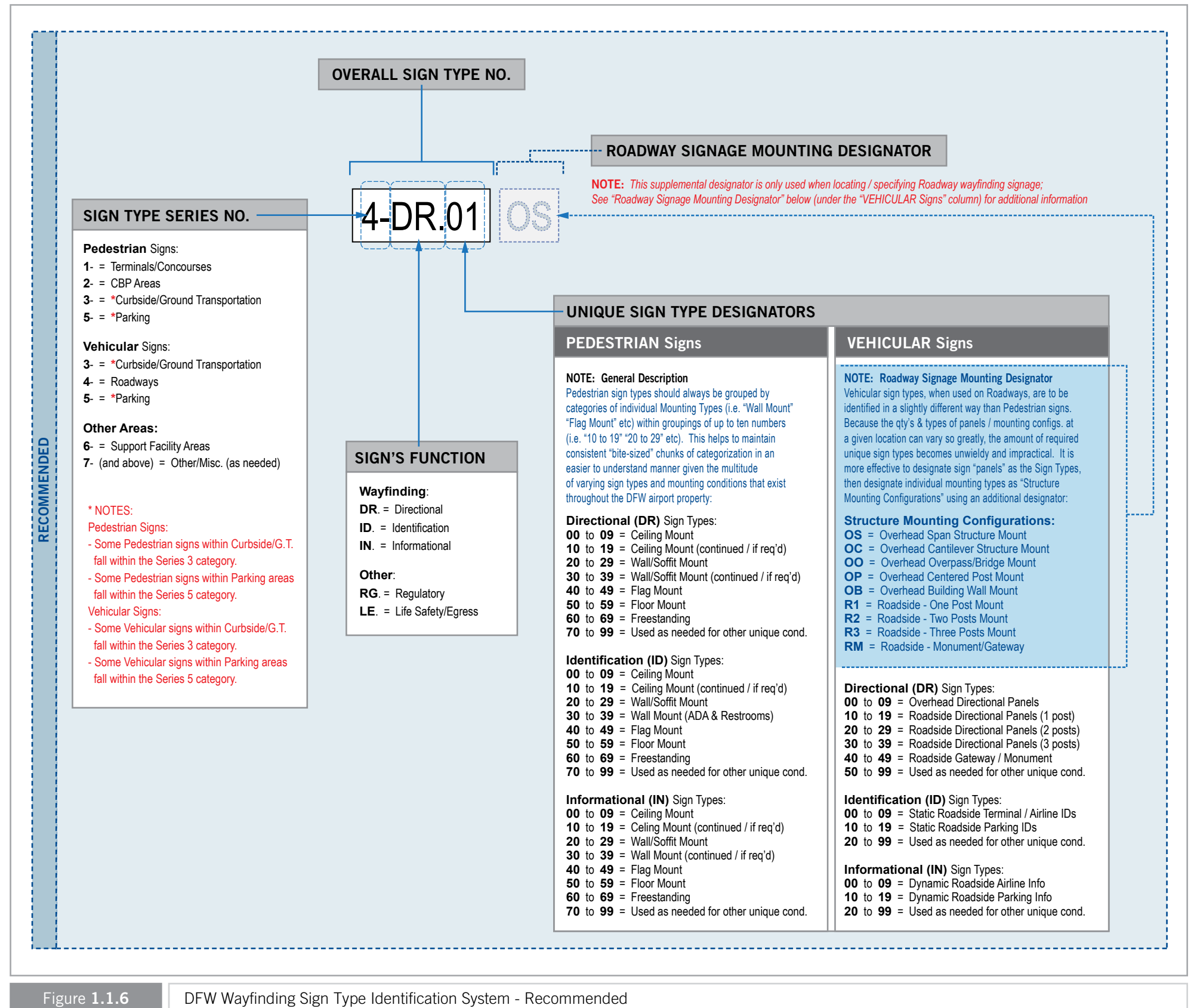

Figure 1.1.6 DFW Wayfinding Sign Type Identification System - Recommended

SIGN TYPE IDENTIFICATION SYSTEM - RECOMMENDED

The vast amount of differing architectural and site conditions at DFW airport facilities, combined with the fact that a standardized sign type identification system doesn't currently exist, creates a need for a comprehensive and holistic sign identification system. This ID system should always maintain standardization, flexibility and ease-of-understanding for the majority of individuals specifying and programming updated and new wayfinding signage at DFW. It is recommended that all DFW wayfinding signage be grouped into the following categories:

- Pedestrian Signs (*NOTE: Certain vehicular signs also fall within these Series numbers)
 - Series 1: Terminals / Concourses: Includes: All public-accessible Terminal and Concourse related areas
 - Series 2: CBP Required Signage: Includes: Areas as controlled by the U.S. Customs and Border Protection
 - *Series 3: Curbside / Ground Transportation: Includes: All Curbside and Ground Transportation related areas
 - *Series 5: Parking: Includes all on-property public-accessible garages and surface lots
- Vehicular Signs
 - Series 4: Roadways: Includes all on-property public-accessible roads
- Other Areas
 - Series 6: Support Facility Areas
 - Series 7 (and above): Are to be assigned as needed and based on unique requirements of individual projects. Note that all expanded series numbering and categorization must be coordinated with DFW for final approval

Pedestrian vs. Vehicular Sign Identification Systems

Pedestrian and vehicular wayfinding signage should always use similar sign type numbering and categorization methods to maintain a holistic identification system across the entire wayfinding program (see Figure 1.1.6). However, each traffic type also has unique requirements and/or mounting configurations associated with them. As such, the identification system is more effective when supplemental designators are applied to their respective systems as needed.

Roadway Signage - Unique Mounting Designator

See Figure 1.1.6, "Roadway Signage Mounting Designator" detail for a general description of the unique designator that should be applied to all DFW roadway wayfinding signage, as well as how to use it for roadway signage identification (see also Figure 1.1.5c for additional information regarding recommended roadway signage location annotation standards).

Variant/Option Designator

When a sign type requires a variant or option (due to sizing variations, directional end-facing, etc.), a unique designator using a lowercase letter at the end of the sign number should be used. For example, a wall mount directional sign type "1-DR.23" is designed for a left-justified directional layout/accent trim. However, when a right-justified layout is required, the accent trim must appear on the right side. In this instance, "1-DR.23b" would be used to designate the right-facing variant.

1.1.7 GENERAL GRAPHIC STANDARDS

INTRODUCTION

It is important to maintain and use a consistent, universally applied set of graphic standards and guidelines when implementing a wayfinding system. As such, general graphic standards and guidelines for the DFW wayfinding signage system are provided within this section.

General graphic design standards identified herein are to serve as the foundational basis for all DFW wayfinding signage. As individual project specifics dictate, these standards are subject to modification and expansion in order to accommodate various design requirements throughout DFW. However, in all cases the modification of design standards must be based in the same sound wayfinding principles established within this document. Designers will adhere to the general graphic standards established herein in regards to elements such as:

- Messages
- Typography
- Symbols
- Arrows
- Colors
- Art, Advertising and Amenities

GENERAL DESIGN CONSIDERATIONS

In addition to specific graphic standards found within this section, the following list of general design considerations should be used by designers when implementing new and/or updated DFW wayfinding signage:

- Consistency and Standards-Based: Consistent visual/graphic presentation across the entire wayfinding system to include:
 - Graphics/Colors/Typefaces/Arrows/Symbols
 - Shapes/Proportions/Sign Types
 - Placement/Orientation & Rotation Philosophy/Decision Points
- Subscribe to established design standards and requirements:
 - Accessibility (ADA)
 - MUTCD/TXDOT (vehicular signage)
 - Sustainability (LEED) whenever possible
- Sign Types
 - Configuration, sizing & placement relative to message priority/function
 - Primary destinations = priority overhead
 - Secondary destinations = secondary overhead or wall mount
 - Tertiary destinations = tertiary wall mount
 - Simplicity, de-clutter, less is better

- Color Coding and Application
 - Sign Background = DFW Wayfinding Blue (PMS 662C)
 - Minimizes confusion with branded Terminal ID and Skylink colors
 - Creates neutral backdrop for messaging and symbols
 - Least visual impact to other existing airport signage during phases of updating
- Multi-Color Discipline
 - Branded colors used as Terminal and train-system related identification accents only;
 - Helps to highlight and differentiate terminals and associated parking facilities, as well as inter-terminal people-mover (trams/shuttles) systems
 - Limited to a small number of priority areas/functions
 - No other colors may be used for DFW wayfinding signage unless otherwise noted and approved by DFW
- Typefaces
 - "Clearview" font family
 - Established as effective for pedestrian and vehicular use
 - Variety of styles that apply to vehicular and pedestrian traffic
 - Sized / kerned appropriately for predicted viewing distances
- Arrows
 - Use only approved DFW wayfinding system arrows and symbols
 - Always scale as locked proportional artwork, no stretching, disproportioning allowed
 - Always maintain consistent alignments and rotation angles
- Use of modern AIGA and DOT Universal Symbol Systems
 - Reinforces destination text
 - Assists international travelers
 - New/custom symbols only allowed upon DFW review and approval
- Message Hierarchy
 - Primary – priority destinations (largest, most visible)
 - Secondary – secondary destinations (may be swapped with primary destinations depending on location in airport; supplemental)
 - Tertiary – auxiliary/support destinations and functions
- Message Functions
 - Directional – direct to destination point(s)
 - Identification – identify destination point(s)
 - Informational – convey detailed information
 - Regulatory – describe regulations, warnings & requirements
 - Life-Safety/Egress – describe safety and egress related information
 - Interim (aka Temporary) – may be any of the above, but used during interim conditions

WARNING:

This record contains Sensitive Security Information that is controlled under 49 CFR parts 15 and 1520. No part of this record may be disclosed to persons with a "need to know," as defined in 49 CFR parts 15 and 1520, except with the written permission of the Administrator of the Transportation Security Administration or the Secretary of Transportation. Unauthorized release may result in civil penalty or other action. For U.S. government agencies, public disclosure is governed by 5 U.S.C. 552 and 49 CFR parts 15 and 1520.

MESSAGE FUNCTIONS

This section defines the four basic functions of a “message” as it pertains to the DFW wayfinding system. It is to be utilized by anyone designing or specifying new or updated wayfinding signage to be implemented at DFW airport properties.

Directional Messages

Directional messages are the main source of information enabling wayfinding traffic to choose the proper route to a specific destination point. This process involves selecting the correct destination point, and then determining at which point a change of direction will be required. Properly placed directional signage at decision points in adequate quantities is necessary for rapid movement of passengers, employees and vehicles.

Identification Messages

Identification messages mark specific locations/destinations within a defined area or environment (i.e., Restroom identification, gate identification, bag claim identification, etc.). In addition to these locations, identification messages provide proper public exposure to leased tenant spaces and other spaces as governed by Airport Management.

Informational Messages

Informational messages typically provide specific, detailed and supplementary wayfinding information to assist in orientation within an unfamiliar and/or complex environment. In addition, informational messaging that is graphic in nature (i.e. directory maps or interactive kiosks) help with providing precise locations for the user in context to the overall facility and its destinations/amenities/etc.

Regulatory / Safety Messages

Regulatory/Safety messages relate to DPS, FAA, TSA and CBP requirements, as well as other federal, state, and local city codes/regulations. In general, these messages provide travelers with important regulatory information, such as travel advice, warnings and restrictions.

Temporary Messages

Temporary messages generally fall into a separate category of messages, and are typically established during the course of fluctuating interim wayfinding conditions due to construction related processes. Temporary signs shall only be used on an interim basis while permanent signs are in the process of fabrication, repair and/or maintenance. Temporary signs are also an excellent way to test new wayfinding elements and locations prior to final fabrication. Note that all temporary messages shall be reviewed and approved by DFW Planning Department and Airport Management prior to implementation.

MESSAGE HIERARCHY

This section defines standards for a complete and uniform hierarchy of DFW wayfinding system messages and terminology. These standards shall be utilized for all new and updated wayfinding signage implemented at DFW airport facilities.

The need for visual continuity among all messages and information of the same hierarchy will help eliminate elements which may interrupt the functional wayfinding process or add confusion. Clear and concise information presented by Primary and Secondary signs/messaging systems ensure efficient passenger circulation. Tertiary signs/messaging must be coordinated with primary and secondary signs/messaging, as well as interior design features and elements. This tertiary category of signs should also be visually distinguished from other wayfinding signs.

Messages will be organized and maintained within three distinct and functionally tiered categories: Primary, Secondary and Tertiary (see Figure 1.1.7a for full message hierarchy lists).

Primary Messages

This information shall be the largest and the most visible information on each sign. Primary information includes, but may not be limited to:

- Exterior direction to and identification of Terminal(s)
- Exterior direction to major vehicular arteries (i.e. nearby access roads)
- Interior direction to and identification of multiple Terminals if applicable (i.e. A, B, C, D, E) and inter-terminal transit (i.e. Skylink and Terminal Link)
- Interior direction to and identification of Gates
- Interior direction to and identification of Bag Claim and Ticketing/Check-In

Secondary Messages

This information supplements and reinforces information already conveyed by the primary messages and signs listed above. It usually indicates the auxiliary services and support functions of the facility. Secondary information includes, but may not be limited to:

- Exterior direction to and identification of Ticketing/Check-In, Bag Claim, and specific Parking Facilities/Areas
- Exterior identification of Rental Car Return, Airport Exit, etc.
- Interior direction to and identification of Elevators and Restrooms
- Interior direction to Parking and Ground Transportation

Tertiary Messages

Tertiary sign information supplements both the primary and secondary messages, and typically informs visitors of regulations and warnings. All regulatory/safety signs are generally considered to be tertiary within the DFW wayfinding system. Tertiary information includes, but may not be limited to:

- Exterior and Interior TSA related notification messages
- Interior CBP related notification messages
- Exterior “No Parking” messages
- FAA required warnings, notifications and information

Other messages required by code.

MESSAGE TERMINOLOGY

Basic Requirements

Terminology, or nomenclature as it applies to airport signage and wayfinding systems, is a standardized set of words, syntax, grammar, spelling, and symbols used to communicate information to the user of the airport. Terminology systems ensure that information is presented in a consistent way, and that the content of this information is always clear and concise. When a term is shown with a corresponding symbol, that term will always appear with its symbol as indicated in *Section 1.1.7 Universal Symbols*, unless otherwise noted.

Change Procedures for Terminology

Consistent use of terminology for established messaging within the DFW wayfinding system is always required. All changes to or additions of new terminology shall require coordination, review and approval by DFW Planning Department.

FOREIGN LANGUAGE: APPLICATION & USE

Universal Symbols

Using universal symbols will assist international and non-English speaking travelers with locating airport destinations in a universal manner, while also eliminating the possibility of unintended bias for individual groups and languages. See *Section 1.1.7 Universal Symbols*.

Informational Wayfinding Signage and Supplemental Materials

Accommodating multiple languages on informational wayfinding signage (i.e. directories and information centers), as well as supplemental materials (such as hand-outs and maps) is the recommended and preferred method of providing detailed wayfinding information to the most diverse groups of non-English speaking airport users. Standards and guidelines for this type of information is not covered within this document and is to be coordinated with DFW as applicable and required.

Foreign Language Translations

All foreign language translations that are used within the DFW wayfinding system are to be provided by professional translators and will be coordinated with DFW staff for final approval prior to final fabrication and installation. All foreign language translations will use the most common and universal dialect for each individual foreign language as deemed appropriate by professional translators.

Dynamic Signage

Dynamic signage can be helpful with displaying multiple foreign languages if needed on monitors, FIDS, and BIDS to convey important information. This allows for flexibility to accommodate a diverse passenger demographic.

WARNING:

This record contains Sensitive Security Information that is controlled under 49 CFR parts 15 and 1520. No part of this record may be disclosed to persons with a “need to know,” as defined in 49 CFR parts 15 and 1520, except with the written permission of the Administrator of the Transportation Security Administration or the Secretary of Transportation. Unauthorized release may result in civil penalty or other action. For U.S. government agencies, public disclosure is governed by 5 U.S.C. 552 and 49 CFR parts 15 and 1520.

RECOMMENDED SIGN USE / FUNCTION	MESSAGE PRIORITY		
	PRIMARY	SECONDARY	TERTIARY
Directional Overhead	Dallas-Forth Worth International Airport Terminals XXXX (X = A, B, C, D, E) Terminal X (X = A, B, C, D, E) X Parking (X = A, B, C, D, E) Rental Cars North Exit; South Exit Return to Terminal Major surrounding access road names	Departures (<i>don't use "Ticketing" on roads</i>) Arrivals (<i>don't use "Bag Claim" on roads</i>) Express North Parking Express South Parking Remote North Parking Remote South Parking 1 Hour Parking	Airline names Curbside Bag Check
Directional Roadside	Rental Car Return; Rental Car Pick-Up Express North Parking Express South Parking Remote North Parking Remote South Parking North Exit; South Exit	Airline names Oversize Vehicles Rental Car Center Rental agency names	DFW Business Center
Identification	Dallas-Forth Worth International Airport Terminal X (X = A, B, C, D, E) Parking X (X = A, B, C, D, E) Airline names	Departures (<i>don't use "Ticketing" on roads</i>) Arrivals (<i>don't use "Bag Claim" on roads</i>) Express North Parking Express South Parking Remote North Parking Remote South Parking Rental Car Center	Curbside Bag Check Restricted areas Reserved Parking On-airport hotel names (<i>Hyatt Regency; Grand Hyatt</i>)
Information/Orientation	Dynamic airport information		Safety related information Hazards/warnings
Regulatory/Safety	No Parking Fire Lane Caution: Pedestrians Crossing Authorized Personnel Only	Tow Away Zone Do Not Enter All FAA, TSA notices All Airport notices	

ROADWAYS

RECOMMENDED SIGN USE / FUNCTION	MESSAGE PRIORITY		
	PRIMARY	SECONDARY	TERTIARY
Directional	Vehicular: - X Parking (X = A, B, C, D, E) - Gates X#-X# (X=A, B, C, D, E) - EXIT - Level X (X = 1, 2, 3, 4, 5, etc.) - DOWN to Level X (X = 1, 2, 3, 4, 5, etc.) - UP to Level X (X = 1, 2, 3, 4, 5, etc.) Pedestrian: - Terminal X (X = A, B, C, D, E) - Sections X-X (X = A, B, C, D, E, etc)	Vehicular: - Valet - Valet / 1 Hour - 1 Hour - 2 Hour - Additional - High Vehicles Pedestrian: - DFW Valet	Pedestrian: - Elevators - Stairs
Identification	X Parking: X Parking North, Central, South - (X = A, B, C, D, E) EXIT Level X (X = 1, 2, 3, 4, 5, etc.) Section X# (X = A, B, C, D, E) Express North Parking Express South Parking Remote North Parking Remote South Parking	Valet 1 Hour 2 Hour	Elevators Stairs
Information/Orientation	Parking rate information Parking spaces open/occupied counters Parking Directory	Handicap / Accessible Parking	Restricted areas Reserved Parking
Regulatory/Safety	No Parking No Parking Tow-Away Zone No Parking Fire Lane	DO NOT ENTER CLEARANCE: X'-X"	

GARAGES/PARKING

RECOMMENDED SIGN USE / FUNCTION	MESSAGE PRIORITY		
	PRIMARY	SECONDARY	TERTIARY
Directional	Terminal X (X = A, B, C, D, E) Ticketing/Check-In All Gates Security Checkpoint Bag Claim Bag Claim X#-X# (X = A, B, C, D, E) Ground Transportation International Arrivals	Gates X#-X# (X = A, B, C, D, E) Airline names Passenger Pick-Up Individual ground transportation names: - Terminal Link, Taxi, Pre-Arranged Limo, Shared Ride, Rental Cars, Public Transit, Express/Remote (for parking shuttles), Courtesy Vans, DART Bus/Rail, Texrail, TNC (Transportation Network Companies such as Uber, Lyft, etc.), Charter Bus, etc X Parking (X = A, B, C, D, E) Hourly/Daily Parking; Economy Parking Toilets	Pet Relief Area Tenant/concession/amenity names Telephones Lockers First Aid AED Police
Identification	Terminal X (X = A, B, C, D, E) Ticketing/Check-In Bag claim carousel no.'s (<i>alpha-numeric</i>) Ground Transportation	Airline names Individual ground transportation names: - Terminal Link; Taxi; Pre-Arranged Limo; Shared Ride; Rental Cars; Public Transit; Express/Remote (for parking shuttles); Courtesy Vans; DART Bus/Rail Elevator (or Elevator to:) Escalator (or Escalator to:) Toilets Men; Women; Family Baggage Information Baggage Services	Entry numbers (<i>aka "Door" numbers</i>) Pet Relief Area Telephones First Aid ATM; Currency Exchange Room numbers; room names Employee information Non-public spaces Advertising All tenant/concession/amenity names (<i>i.e. ACO, USO, Traveler's Aid, Credit Union, Chapel, Vending, etc</i>)
Information/Orientation	All directories (<i>static and dynamic</i>) FIDS / BIDS / GIDS	Visual paging systems	Safety related information Hazards/warnings
Regulatory/Safety	Exit / Emergency Exit Only No Smoking / Smoking Area	All FAA, TSA notices Authorized Personnel Only	AED Fire Extinguisher Yield to Pedestrians No Stopping, Standing, Parking

TERMINALS - LANDSIDE (Ticketing/Bag Claim/Curbside Areas)

RECOMMENDED SIGN USE / FUNCTION	MESSAGE PRIORITY		
	PRIMARY	SECONDARY	TERTIARY
Directional	Gates X#-X# (X = A, B, C, D, E) Bag Claim (<i>do not include carousel alpha-numeric ranges on airside signs</i>) Bag Claim/Exit Skylink to: XXXX (X = A, B, C, D, E)	Toilets Men; Women; Family Airline club names Elevator (or "Elevator to:") Escalator (or "Escalator to:")	Amenities (<i>USO, etc</i>) Grand Hyatt Hyatt Regency
Identification	Gate numbers (<i>number only, don't use the word "Gate" on IDs</i>) Skylink	Elevator Toilets Information Flight Information Connecting Information	Room numbers; room names Employee information Non-public spaces Advertising All tenant/concession/amenity names (<i>i.e. ACO, USO, Traveler's Aid, Credit Union, Chapel, Vending, etc</i>)
Information/Orientation	Airport directories (static and dynamic) FIDS / CGIDS	Visual paging systems	All required TSA/CBP notices Safety related Hazards/warnings
Regulatory/Safety	Exit / Emergency Exit Only No Smoking	All FAA, TSA notices Authorized Personnel Only Do Not Enter	AED Fire Extinguisher

TERMINALS - AIRSIDE (Concourses/Holdrooms/Gate Areas)

Figure 1.1.7a

DFW Wayfinding Message Hierarchy Lists: Recommended

WARNING:

This record contains Sensitive Security Information that is controlled under 49 CFR parts 15 and 1520. No part of this record may be disclosed to persons with a "need to know," as defined in 49 CFR parts 15 and 1520, except with the written permission of the Administrator of the Transportation Security Administration or the Secretary of Transportation. Unauthorized release may result in civil penalty or other action. For U.S. government agencies, public disclosure is governed by 5 U.S.C. 552 and 49 CFR parts 15 and 1520.

MESSAGE APPLICATION

Wayfinding messages at DFW airport facilities will be applied in a holistic and consistent manner. This includes the order of how wayfinding messages are listed, as well as the allowable number/quantity of wayfinding messages that are allowed on DFW wayfinding signage.

Listing Order

The majority of the international population read and decipher information in a prioritized “top-to-bottom” organizational format (see Figure 1.1.7b). As a result, wayfinding destinations are typically prioritized/listed as:

- The most important destinations or closest in proximity are listed first
 - i.e. the highest priority and/or closest proximity at the top
- Subsequent messages are listed in descending order downward
 - i.e. the next most important and/or next in order of closest proximity

Number/Quantity of Messages

Directional messaging, for both pedestrian and vehicular traffic, tends to be overwhelming when more than three messages are used for a single direction on directional signage. Limiting the number/quantity of messages in a single direction is important for rapid deciphering of messaging while maintaining smooth wayfinding circulation flows.

Note that directional messaging should typically be limited to two messages for a single direction whenever possible, and a maximum of no more than three messages for a single direction. Four messages, although sometimes necessary and will depend on unique wayfinding circumstances, is not preferred and should be limited whenever possible. If four messages are deemed necessary, they should typically be limited to secondary or tertiary messaging/sign types (see Figure 1.1.7b).

MESSAGE FUNCTION AND HIERARCHY RELATIONSHIPS

Along with prioritizing wayfinding messages in a hierarchy format (i.e. Primary vs. Secondary vs. Tertiary messages), they will also typically have functional properties associated with them (i.e. general vs. specific). They will also typically determine the categorization of sign type priority (i.e. Primary, Secondary and Tertiary sign types).

Message Priority Categorization and Function

It is important to understand that the same message may fall under a different priority category depending on its use and location within the overall wayfinding system. For example, traffic on a roadway approaching a terminal may find the term “Parking” as a primary message. However, the same term found in the terminal may be considered secondary when compared to other destinations in the terminal facility.

A message’s function will also typically change from the more general (i.e. “Terminal” or “Ground Transportation”) to the more specific (i.e. “Terminal A” or “Taxi, Shuttles, etc.”) as wayfinding traffic moves through an area/facility and approaches their destinations. Consistently maintaining this same functional use for messages throughout the entire wayfinding system is essential to smooth wayfinding traffic flow, and establishes solid visual continuity among messages/information and the sign system itself.

Message Priority and Sign Type Priority

The relationship between message function and message hierarchy also creates a basic foundation for the classification and determination of sign types. Message hierarchy (i.e. Primary, Secondary and Tertiary messaging) is used to group messages for their general use on directional, identification and informational sign types, each with their own specific application and usage priorities (i.e. Primary, Secondary and Tertiary sign type classifications).

Message Grouping by Priority

Emphasis should be placed on the reduction of signs and the amount of messaging wherever possible. However, it is typically a given that airport wayfinding sign systems are complicated with large quantities of varying sign types and associated messaging. As such, grouping messages by priority is necessary, and will result in fewer unique sign and message types.

For example, primary messages should typically be grouped with other primary messages whenever possible. If there is need for secondary messaging on the same sign, its importance will always be secondary to all primary messages. Ultimately, secondary messages may be better used on secondary sign types (if deemed appropriate for a given circumstance/condition or environment).

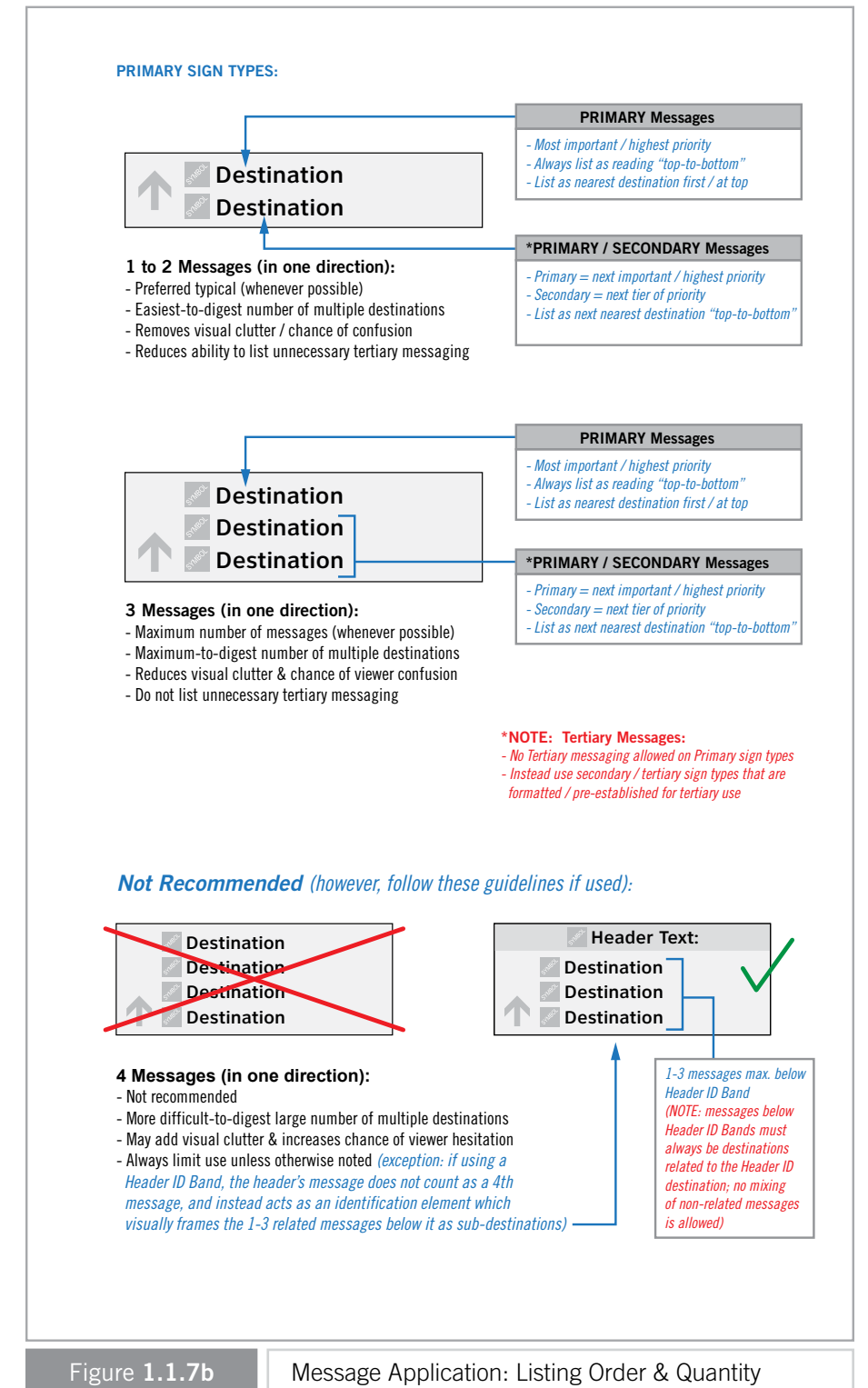

Figure 1.1.7b

Message Application: Listing Order & Quantity

TYPOGRAPHY

Clearview Text Medium and Clearview Text Bold (Pedestrian signage) and Clearview Highway (Vehicular/Roadway signage) typeface shall be the only typefaces used for all airport wayfinding signage at DFW (except for TXDOT, general DOT and regulatory signs). All sign text shall be set in approved Clearview family typefaces, unless otherwise specified.

Other weights and styles of the Clearview typeface family may be appropriate in unusual circumstances. Recommendations to use alternate type weights must be submitted for approval by the DFW Planning Department. Justification of such proposals shall demonstrate the advantage offered by the non-standard type and the relationship of the non-standard sign to the other signing in the area of the proposed use.

Pedestrian Typeface (see Figure 1.1.7c):

- ClearviewText font family will be the standard font used for all pedestrian/interior and garage signs
- ClearviewText Medium is the basic letter proportion used for directional and wayfinding signs (i.e. overhead, wall-mounted, etc.)
- ClearviewText Medium will be used for wall-mounted room ID signs
- ClearviewText Medium will be used for regulatory signs, with ClearviewText Bold used where emphasis is required
- ClearviewText Book may be used on informational signs (i.e. information boards, guidelines, etc.)
- ClearviewText Bold will be used for gate identification signs

Vehicular Typeface (see Figure 1.1.7d):

Guide signing for DFW Airport roadways shall incorporate the Clearview Highway font series according to the following classification and usage guidelines:

- Clearview Highway 5W shall typically be used for all guide signing with primary and secondary destinations and messages
- Clearview Hwy 5W font is the replacement for FHWA Standard Highway Gothic font series Emodified, and may be used for letter heights down to and including 6 inches
- Clearview Hwy 5W will be used for the parking symbol letter “P” as well as numerals appearing in the main field of a guide sign, such as parking rates
- Clearview Highway 4W is the replacement for FHWA Series E and shall be used for all action messages such as EXIT, STOP AHEAD or KEEP RIGHT typically found in footer panels
- Clearview Hwy 4W is used for cardinal directions when used to indicate route direction, and numerals used in footer panels indicating distances
- Clearview Highway 3W may be used on arterial, collector and local roadways for replacement of FHWA Series D and used where panel sizes are limited
- Clearview Highway 3W is used for letters in the Terminal Identifier Symbols
- Clearview Highway 2W will be used for on street name signs or signing in low speed areas when Clearview Highway 5W, or 4W or 3W cannot be applied

CAPITALIZATION

Aside from special decorative uses and certain regulatory signs, all sign word messages shall be in initial uppercase followed by lowercase (aka “Title Case”). Examples of exceptions:

- EXIT
- DO NOT ENTER
- KEEP LEFT; KEEP RIGHT
- NEXT LEFT; NEXT RIGHT
- ATM

Additionally:

- As required by the American with Disabilities Act, all tactile messages should be all uppercase
- For better legibility, lower case letters should have a lowercase “x” height that should be two-thirds the height of the uppercase letter
- All words should be first letter capitalized except for articles, prepositions, and conjunctions
- A consistent capital letter height will be maintained when signs are used in sequence

TYPOGRAPHIC RESTRICTIONS

Typefaces or weights not described above should not be used, unless deemed acceptable by the DFW Planning Department. Modification of letter shapes is prohibited. Condensed, extended, slanted, outlined or otherwise distorted type should not be used. Language to this effect should be included in the specifications for all additional airport sign projects and any variances must be approved by the DFW Planning Department.

LETTER SPACING

Unless otherwise indicated, all sign messages shall follow the vendor’s normal or “kerned” letter spacing standards. Messages set according to the type vendor’s letter spacing standards will not normally require adjustment. In some circumstances, modification of spacing between individual letter pairs may improve the appearance and legibility of a sign message. Designers are required to review sample messages for all sign projects and shall recommend spacing modifications where they can be shown to be advantageous. In these instances hand-kerning will be required to adjust spacing. Also, hand-kerning may be required on internally illuminated signs to prevent “halation” of the letters. Reducing normal letter or word spacing (e.g. to fit lengthy message within a restrictive layout area) should be avoided. Punctuation marks, which relate to two letters, should be spaced equally from both letters.

WORD SPACING (see Figure 1.1.7e)

Word spacing between related words is typically 3/4 (.75) times the cap letter height, unless otherwise noted. (For example, a message using 4” cap letters will have 3” between words).

LINE SPACING (see Figure 1.1.7f)

Line spacing is typically 1/2 (.50) times the cap letter height for words of a related message line, unless otherwise noted. Spacing between unrelated messages is typically one times the cap height, unless otherwise noted.

TYPE SIZES

The following are the standard typical type sizes for most sign messages at DFW, and should be used only as a general guideline when developing new sign types. Also, larger type sizes may be used in special decorative instances. All variations from these standards must be approved by the DFW Planning Department. See the DFW Signage Standards and Guidelines for listings and layouts of individual type sizes per approved wayfinding sign type.

Exterior

- Roadway (based on MUTCD/TXDOT)
 - Overhead Vehicular Sign Messages:
 - Primary = 16” minimum; Secondary = 12”; Tertiary = 12”
 - Roadside Post-Mounted Sign Messages:
 - Primary = 8” minimum; Secondary = 6”; Tertiary = Varies
 - Regulatory Sign Messages:
 - Refer to the TXDOT Traffic Manual, the Federal Manual of Uniform Traffic Control Devices (MUTCD), or City Municipal Code.
- Curbside
 - Overhead Directional Messages:
 - Primary = 3.5” to 4”; Secondary = 3”
 - Suspended Identification Messages:
 - Primary = 6”; Secondary = 4”
- Parking
 - Overhead Vehicular Directional Messages = 6” typical; 5” minimum
 - Overhead Pedestrian Directional Messages = 4” typical; 3” minimum
 - Level / Section Identification = 4” minimum

Interior

- Interior Directional Signs
 - Overhead Directionals:
 - All messages = 3.5” to 4” typical; 3” minimum
- Interior Identification Signs
 - All messages = Varies (see individual sign type layouts)
- Interior Informational Signs
 - Directory messages = Varies (see individual sign type layouts)
- Interior Regulatory and Safety Signs
 - Refer to latest edition of the ADA and all other current local, state & national codes

WARNING:

This record contains Sensitive Security Information that is controlled under 49 CFR parts 15 and 1520. No part of this record may be disclosed to persons with a “need to know,” as defined in 49 CFR parts 15 and 1520, except with the written permission of the Administrator of the Transportation Security Administration or the Secretary of Transportation. Unauthorized release may result in civil penalty or other action. For U.S. government agencies, public disclosure is governed by 5 U.S.C. 552 and 49 CFR parts 15 and 1520.

ABCDEFGHIJKLMNOPQRSTUVWXYZ
 abcdefghijklmnopqrstuvwxyz
 1234567890 !@#\$%^&*()-+=*/

Pedestrian - Directional Signs: **ClearviewText Medium**

ABCDEFGHIJKLMNOPQRSTUVWXYZ
 abcdefghijklmnopqrstuvwxyz
 1234567890 !@#\$%^&*()-+=*/

Pedestrian - Identification Signs: **ClearviewText Bold**

Figure 1.1.7c

Wayfinding Typefaces: **Terminal/Curbside/Garage Areas**

ABCDEFGHIJKLMNOPQRSTUVWXYZ
 abcdefghijklmnopqrstuvwxyz
 1234567890 !@#\$%^&*()-+=*/

Vehicular Signs - Wayfinding: **Clearview Highway 5W**

ABCDEFGHIJKLMNOPQRSTUVWXYZ
 abcdefghijklmnopqrstuvwxyz
 1234567890 !@#\$%^&*()-+=*/

Vehicular Signs - Exit Queuing: **Clearview Highway 3W**

Figure 1.1.7d

Wayfinding Typeface Examples: **Roadway Areas**

.75X
 X **Baggage Claim**

X = Letter Capital Height

Figure 1.1.7e

Typical Wayfinding Word Spacing

X
 .5X
 1X
 Ground
 Transportation
 Baggage Claim

Align

X = Letter Capital Height

Related Lines of Text

Unrelated Lines of Text

Figure 1.1.7f

Typical Wayfinding Line Spacing

WARNING:

This record contains Sensitive Security Information that is controlled under 49 CFR parts 15 and 1520. No part of this record may be disclosed to persons with a "need to know," as defined in 49 CFR parts 15 and 1520, except with the written permission of the Administrator of the Transportation Security Administration or the Secretary of Transportation. Unauthorized release may result in civil penalty or other action. For U.S. government agencies, public disclosure is governed by 5 U.S.C. 552 and 49 CFR parts 15 and 1520.

UNIVERSAL SYMBOLS

The following (Figure 1.1.7g) lists the standards for typical universal symbol usage at DFW. Typical universal symbols will be DFW Wayfinding Blue (PMS 662C) artwork on White background field (rounded corners) unless otherwise noted (i.e. Terminals/Gates, Ground Transportation, Terminal Link/Skylink and certain regulatory symbols will have unique colors as shown here). Use only DFW wayfinding program approved proportionally locked vector symbol artwork. No stretching, re-proportioning or other modification is allowed.

TRAVEL SYMBOL - WAY FINDING (Blue background)

PUBLIC SERVICE SYMBOLS - WAY FINDING (Blue background)

CONCESSIONS (Blue background)

GROUND TRANSPORTATION (Blue or other solid background)

TERMINALS (All solid backgrounds)

DFW BRAND LOGOS

SECURITY CHECKPOINT GRAPHICS

REGULATORY (Blue or other solid background)

SWATCH COLORS

LOWER LEVEL CURBSIDE COLORS (Legacy terminals only, Terminal D varies)

UPPER LEVEL COLORS (Legacy terminals only, Terminal D varies)

Figure 1.1.7g DFW Wayfinding Universal Symbols

WARNING:

This record contains Sensitive Security Information that is controlled under 49 CFR parts 15 and 1520. No part of this record may be disclosed to persons with a "need to know," as defined in 49 CFR parts 15 and 1520, except with the written permission of the Administrator of the Transportation Security Administration or the Secretary of Transportation. Unauthorized release may result in civil penalty or other action. For U.S. government agencies, public disclosure is governed by 5 U.S.C. 552 and 49 CFR parts 15 and 1520.

ARROWS

Arrows used as directional elements are more flexible and require less sign layout space than messages. Arrow graphic proportions and artwork should be standardized, and should always be applied in a consistent manner across the entire wayfinding signage system. Note that careful design and review of sign layouts must be done in order to produce proper proportioning between arrows, messages and symbol dimensions.

ARROW APPLICATION GUIDELINES

The angle of rotation and directional information that arrows convey is of equal importance to the consistent use of an arrow's graphic style. The arrow rotation which may be used to convey a message of "straight ahead" is of particular interest. Either "up arrow" or the "down arrow" can be used to convey the same message, but it's application and surrounding environmental context is what drives the differentiation. For example, an arrow pointing "down" near a downward stairway entrance will mean "straight ahead; down these stairs." However, an arrow pointing "down" over the entrance to a queuing lane will conversely mean "straight ahead; use this lane."

Note that once the general context of the directional message to be conveyed has been evaluated and selected, consistent application should always be continued throughout the entire signage system. The following are guidelines when using arrows within DFW's wayfinding system:

Arrow Sign Face Positioning/Sizing Relationship (see Figure 1.1.7h to 1.1.7k)

- The placement of arrows on sign faces should conform to the standards and guidelines provided. Arrows should not be positioned in any other location on the sign face. Arrows should not be stretched or re-proportioned outside of the standard locked-up wayfinding arrow artwork as shown (see Figure 1.1.7i). See the DFW Signage Standards and Guidelines for specific sign type arrow/graphic face layouts.
- Arrows should not point into text:
 - Left-facing arrows should be located on the left side of signs (corresponding message text should be left justified)
 - Right-facing arrows should be located on the right side of signs (corresponding message text should be right justified).
 - Upward-facing arrows are normally located closest to the flow of traffic (corresponding message text should be justified based on arrow location on sign face)
- Roadway Overhead Signs:
 - Arrows should be held within a designated area along the lower edge of the message area. Arrows are normally positioned flush with the bottom edge of the designated arrow area. See the DFW Signage Standards and Guidelines for vehicular sign type arrow/graphic face layouts
- Roadway Roadside Signs:
 - Arrows should be held within a designated vertical column along the left or right side of the message area

- Pedestrian Signs:
 - Arrows should be held within a designated vertical column along the left or right side of the message area. See the DFW Signage Standards and Guidelines Manual for pedestrian sign type arrow/graphic face layouts

Arrow Rotation Angles (see Figure 1.1.7m)

- When used for standardized wayfinding, the standard arrow can be rendered in eight (8) different standard rotation angles
- No alternate angles are acceptable, unless approved by DFW Planning Department

Arrow Applications

- Pedestrian Signs (see Figure 1.1.7n):
 - Arrow rotation angles and applications for pedestrian specific traffic should follow the guidelines provided in this section (see Figure 1.1.7i)
 - Straight-ahead pedestrian movement should be indicated by upward-facing arrows, unless a downward-facing arrow can be shown to be clearly advantageous in a specific circumstance (i.e. queuing lane identification/purposing, etc.)
 - Straight downward-facing arrows are normally reserved to indicate movement to a lower level for pedestrian traffic
- Vehicular Signs (see Figure 1.1.7o):
 - Arrow rotation angles and applications for vehicular specific traffic should follow the guidelines provided in the TXDOT Traffic Manual and the Federal Manual of Uniform Traffic Control Devices (MUTCD). Arrow position on overhead signs shall relate to the traffic lanes and their designated traffic flow

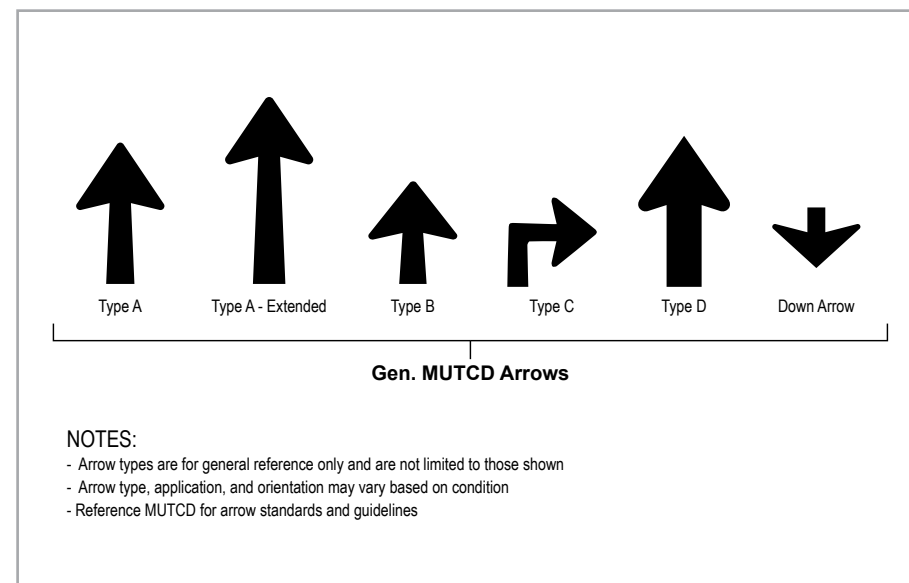
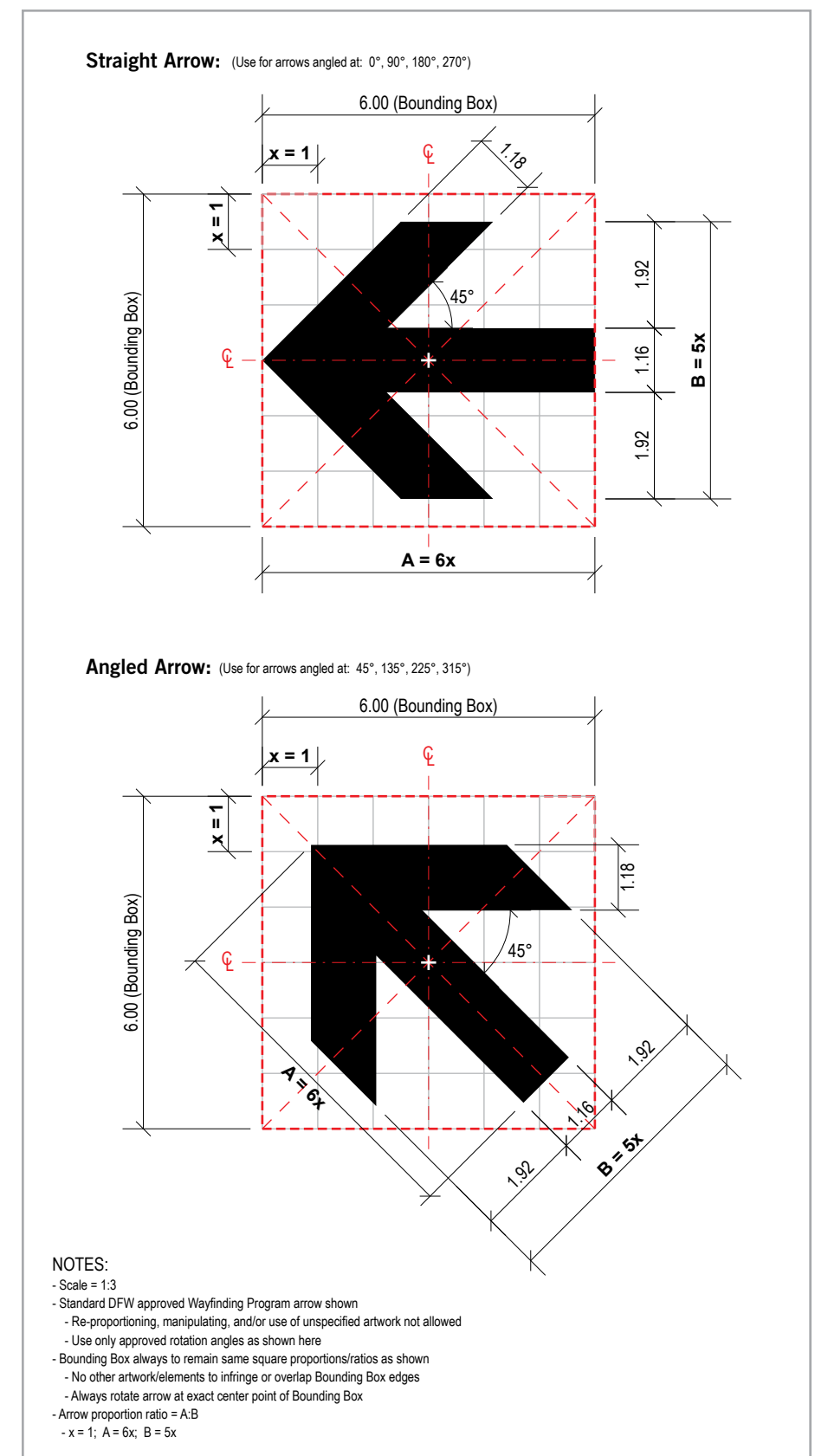

Figure 1.1.7h

Wayfinding Arrows: Vehicular



NOTES:

- Scale = 1:3
- Standard DFW approved Wayfinding Program arrow shown
 - Re-proportioning, manipulating, and/or use of unspecified artwork not allowed
 - Use only approved rotation angles as shown here
- Bounding Box always to remain same square proportions/ratios as shown
 - No other artwork/elements to infringe or overlap Bounding Box edges
 - Always rotate arrow at exact center point of Bounding Box
- Arrow proportion ratio = A:B
 - x = 1; A = 6x; B = 5x

Figure 1.1.7i

Wayfinding Arrows: Pedestrian - Proportions

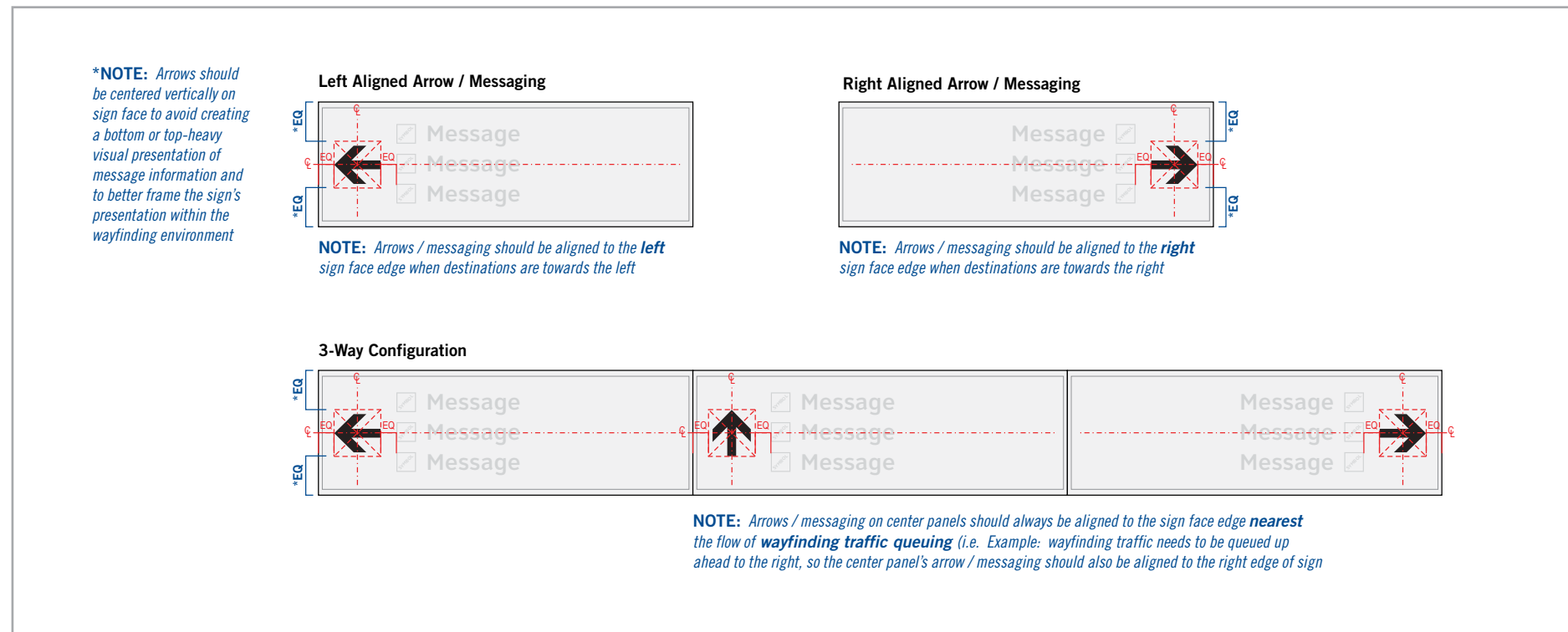

Figure 1.1.7j

Wayfinding Arrows: **Typical Alignment - Pedestrian Terminal/Garage Areas**

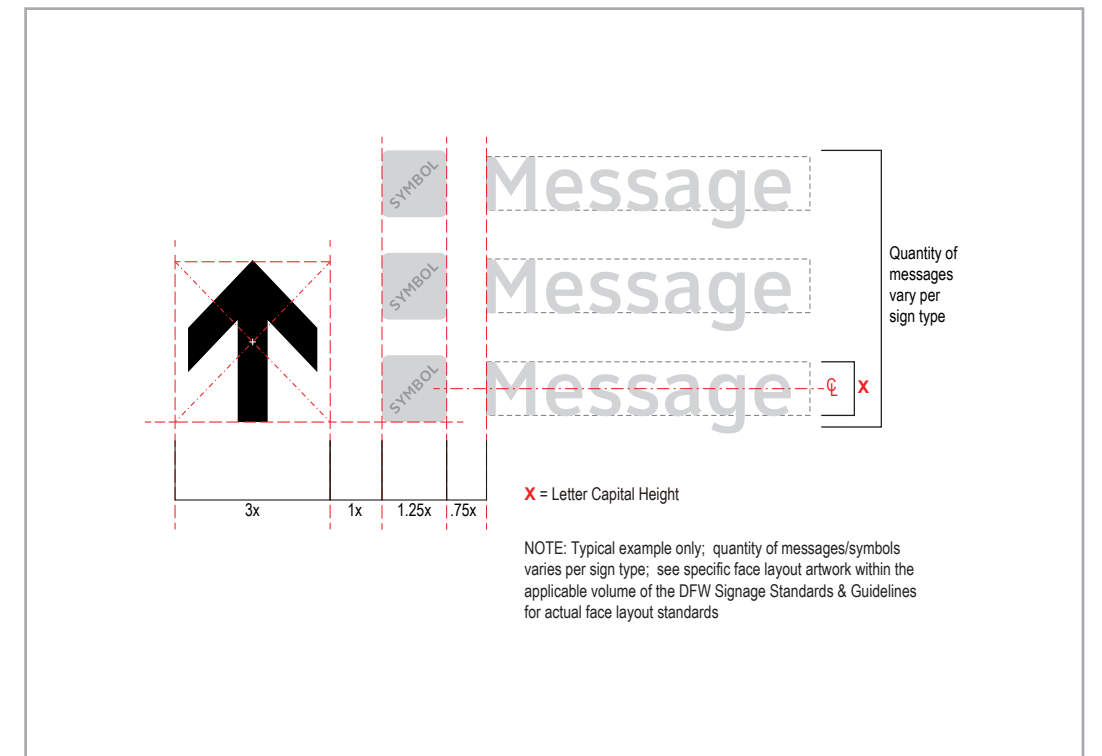

Figure 1.1.7i

Wayfinding Arrows: **Size Relationships - Pedestrian**

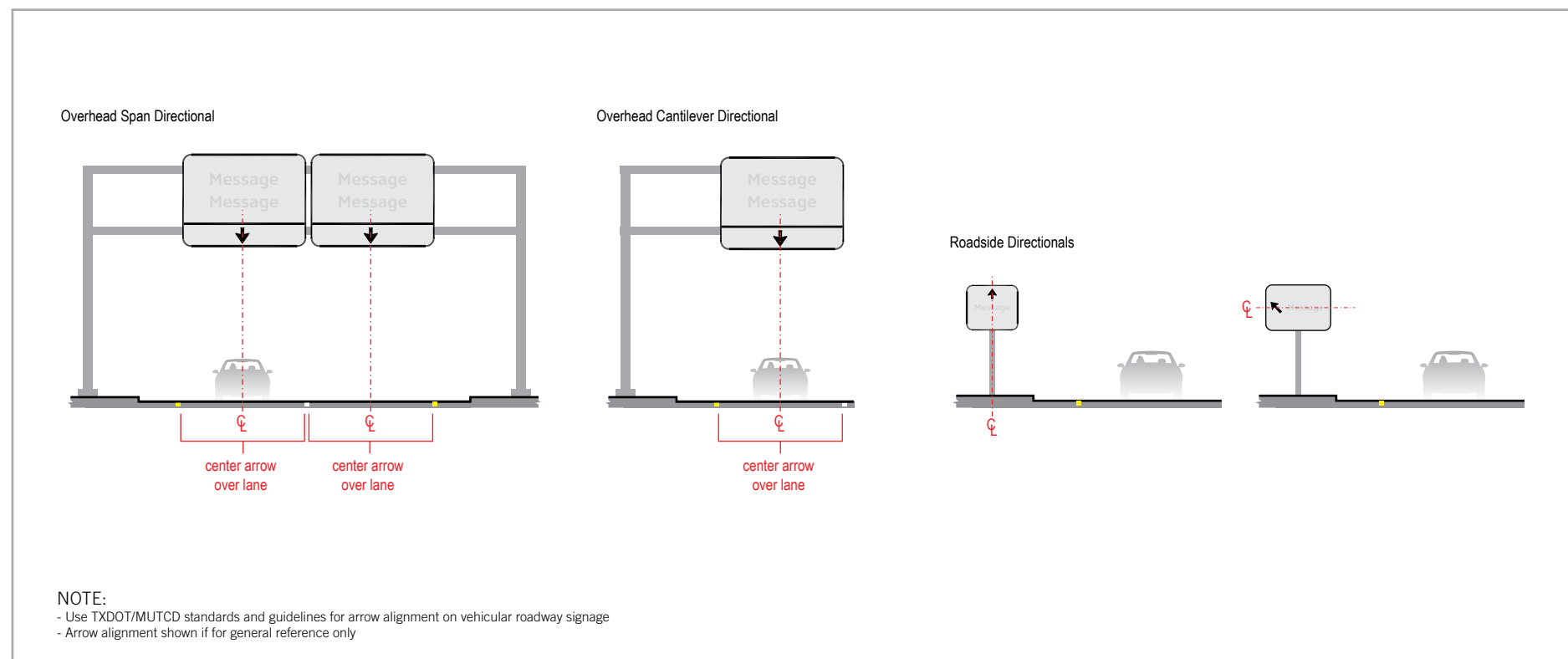

Figure 1.1.7k

Wayfinding Arrows: **Typical Alignment - Vehicular Roadway Areas**

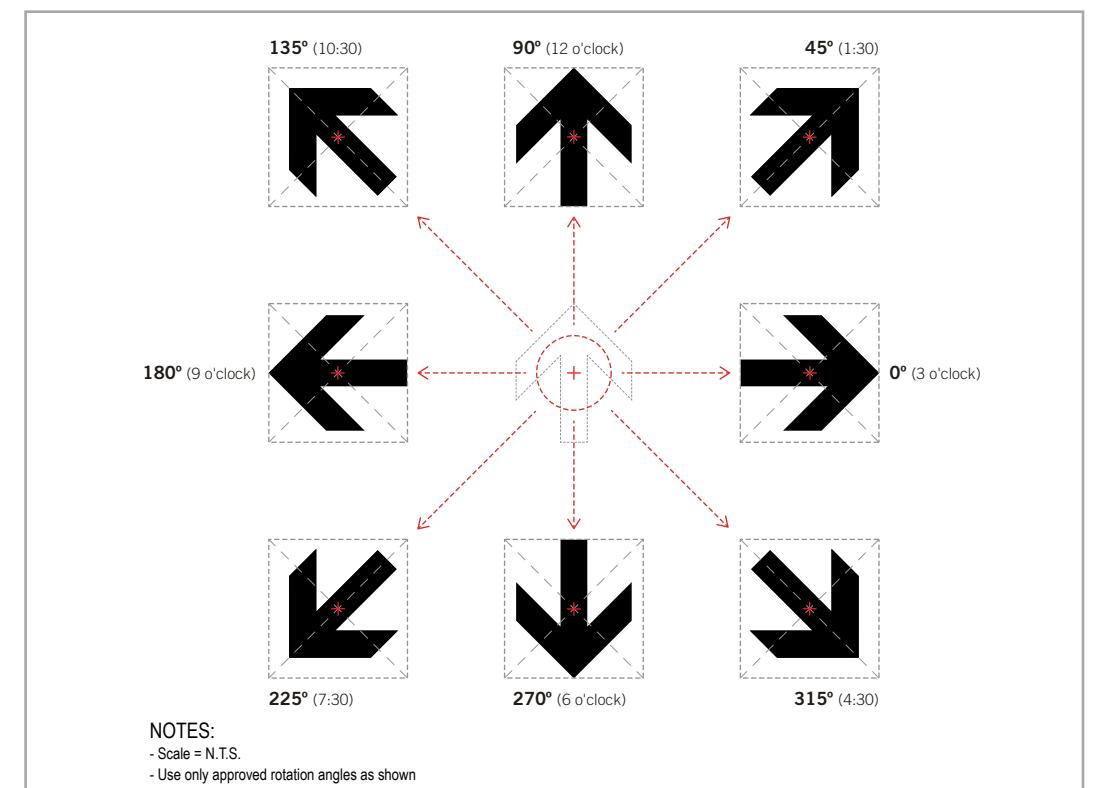

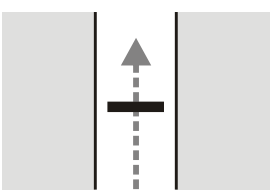

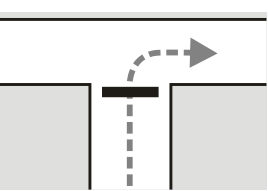

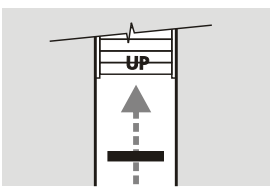

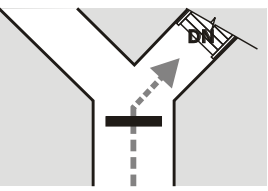

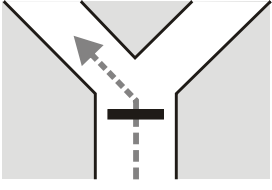

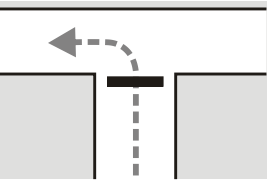

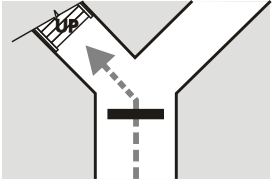

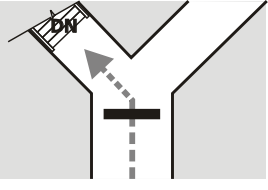

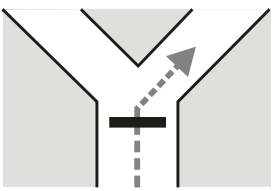

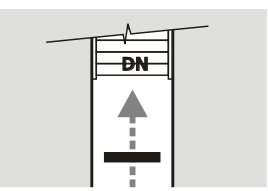

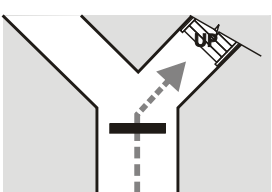

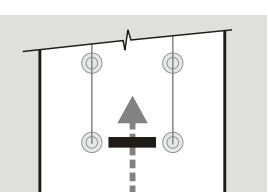

Figure 1.1.7m

Wayfinding Arrows: **Rotation Angles**

ALL Directionals					
ARROW ROTATION	LOCATION PLAN EXAMPLE	MESSAGE CONVEYED	ARROW ROTATION	LOCATION PLAN EXAMPLE	MESSAGE CONVEYED
 90° (12 o'clock)		Straight Ahead	 0° (3 o'clock)		Right
 90° (12 o'clock)		Up	 315° (4:30)		Down on the Right
 135° (10:30)		Ahead on the Left	 180° (9 o'clock)		Left
 135° (10:30)		Up on the Left	 225° (7:30)		Down on the Left
 45° (1:30)		Ahead on the Right	 270° (6 o'clock)		Down
 45° (1:30)		Up on the Right	 270° (6 o'clock)		Use this lane / row / aisle / line

NOTES:
 - Source: Guidelines for Airport Signage & Graphics - Latest Ed.
 - Schematic representations only; drawings not to scale

Figure 1.1.7n

Wayfinding Arrows: Applications - Pedestrian Terminal/Garage Areas

OVERHEAD Directionals		
ARROW ROTATION	LOCATION PLAN EXAMPLE	MESSAGE CONVEYED
Existing: ↑ 90° (12 o'clock)		Straight Ahead (Arrow Justified Center)
Existing: ↓ 270° (6 o'clock)		Straight Ahead: Use This Lane (Arrow Justified Center)
Existing: ↘ 315° (4:30)		Down on the Right (Arrow Justified Center)
Existing: ↙ 225° (7:30)		Down on the Left (Arrow Justified Center)
Existing: ↗ 45° (1:30)		Exit/Ahead on the Right (Arrow Justified Center)
Existing: ↖ 135° (10:30)		Exit/Ahead on the Left (Arrow Justified Center)

CANTILEVER Directionals		
ARROW ROTATION	LOCATION PLAN EXAMPLE	MESSAGE CONVEYED
Existing: ↑ 90° (12 o'clock)		Straight Ahead (Arrow Justified Center)
Existing: ↑ 90° (12 o'clock)		Straight Ahead (Arrow Justified Center)
Existing: ↓ 270° (6 o'clock)		Straight Ahead: Use This Lane (Arrow Justified Center)
Existing: ↓ 270° (6 o'clock)		Straight Ahead: Use This Lane (Arrow Justified Center)
Existing: ↖ 135° (10:30)		Exit/Ahead on the Left (Arrow Justified Center)
Existing: ↗ 45° (1:30)		Exit/Up on the Right (Arrow Justified Center)

ROADSIDE Directionals		
ARROW ROTATION	LOCATION PLAN EXAMPLE	MESSAGE CONVEYED
Existing: ↑ 90° (12 o'clock)		Straight Ahead (Arrow Justified Left)
Existing: ↑ 90° (12 o'clock)		Straight Ahead (Arrow Justified Right)
Existing: ↗ 45° (1:30)		Exit/Ahead on the Right (Arrow Justified Right)
Existing: → 0° (3:00)		To the Right (Arrow Justified Right)
Existing: ↖ 135° (10:30)		Exit/Ahead on the Left (Arrow Justified Left)
Existing: ← 180° (9 o'clock)		To the Left (Arrow Justified Left)

NOTES:
- Arrow applications shown are for general reference only
- Arrow type and application may vary based on condition
- Reference MUTCD for additional standards and guidelines

Figure 1.1.7o

Wayfinding Arrows: Applications - Vehicular Roadway Areas

OVERVIEW

In order to maintain a visually unified system of signs throughout all DFW facilities, the presentation of color must be consistent on all elements throughout the entirety of the wayfinding system. This section will provide an overview of the adopted color system as it should be used for all new and updated wayfinding signage at DFW.

COLOR DESIGN CONSIDERATIONS

The following general design considerations and guidelines should be utilized when specifying the DFW wayfinding color system:

Simple, Supplemental and Consistent

Colors, as they pertain to branding specific elements within a wayfinding environment, should always be simple, supplemental, limited in number and applied consistently and without exception. When too many colors are introduced, it will typically create an additional layer of information to decipher, which in turn may cause increased confusion, pause and distrust of the wayfinding system.

Consideration of Colorblind Individuals

As of this document's publishing, approximately 12% of the population is colorblind and cannot distinguish between mixed shades of red or orange, yellow or brown and black or blue. For this reason, if multiple colors are to be used as a primary means of identifying wayfinding elements (i.e. "The Orange Line," "The Green Room," etc.), then it would be necessary to spell out the name of the color in order to make the intended color usage clear to colorblind individuals, while also meeting related ADA requirements.

Color-Coding

Color-coding, when applied thoughtfully, sparingly and consistently, is a useful supplement to a good linguistic format. Color-coding should not typically be the absolute or primary means of distinguishing parts of a facility, and instead be used in a manner that supplements the primary graphic wayfinding information being presented. For example, applying a unique color to each individual level or area of a parking garage is a common practice among parking facility designers. However, the color use of such a system must be considered within the larger context of the surrounding/nearby facilities and how it will effect their color coding systems. When too many varied colors and/or color systems are used, color becomes yet one more layer to decipher in an already complex hierarchy of wayfinding information.

Recognition, Contrast, Reproduction and Environmental Considerations

Colors should always be chosen for their wide recognition, contrast/legibility, ease of manufacture/reproduction, as well as complementary to the established wayfinding system or surrounding environment. The long-term "survivability" of colors will also be dependent on surrounding weather and environmental conditions (i.e., direct sunlight and ambient light gradually affects color systems over time, typically fading and usually accelerated due to unique or typical local weather conditions). As such, the choice and use of color should always be evaluated to some degree based on the geographic location of the wayfinding environment.

COLOR APPLICATION GUIDELINES

DFW Wayfinding Color System: General Description

The DFW wayfinding system's color palette should always use a *supplemental* wayfinding specific color-coding system that accents and enhances the messaging, while also limiting the use of other branded and/or non-wayfinding related colors. In addition, all colors should be consistently and easily manufactured on signage, maintain good contrast with each other, and appear as a distinctive wayfinding specific color palette that is easily recognized by the majority of wayfinding system users, regardless of location within the airport property.

General Color Application Guidelines and Standards

The following are general color guidelines and standards for use within the DFW wayfinding signage system:

- Sign Graphics - All DFW Wayfinding Signage:
 - The primary sign face background and text colors for all wayfinding signage (vehicular and pedestrian) are White text/symbols on an DFW Wayfinding Blue (PMS 662C) background. These colors were chosen for their widely adopted implementation system-wide at DFW, their high contrast when incorporated within the multitude of DFW's varied wayfinding environments (both interior and exterior areas)
- Sign Graphics - Pedestrian Wayfinding Areas (i.e., terminals, curbsides, pedestrian-related parking areas):
 - The use of White text/symbols on a DFW Wayfinding Blue sign face background avoids competition with color schemes of other competing entities (concessions, airlines, etc..) and integrates well with the varying structural and architectural features found at DFW
- Sign Graphics - Vehicular Wayfinding Areas (i.e., roadways and vehicular-related parking areas)
 - Roadways: White text/symbols on TXDOT blue sign face background creates high contrast and greater legibility from a distance, while traveling at posted speeds; distinguishes the airport's wayfinding sign system from surrounding city, county or state road sign systems; serves to alert motorists that they are traveling within the airport's property limits, and more complex movements will occur in shorter distances; as a means of enhancing the visual queue of leaving the airport's property limits and entering the surrounding city roadway system, roadway directionals nearest to airport exit/property limit areas will utilize TXDOT green backgrounds and graphic formatting
 - Parking Garages: White text/symbols on DFW Wayfinding Blue sign face background creates holistic visuals with pedestrian wayfinding signage
- Branded Terminal Identification:
 - In order to identify the terminals as unique/separate facilities at DFW, the terminals will be branded with symbols unique from the other standard wayfinding symbols by utilizing the following colors:
 - Symbol field background = DFW Wayfinding Blue (PMS 662C)
 - Terminal ID letters = White

- Symbol borders = Gold (PMS 130C)
- Ground Transportation Identification (at curb areas):
 - Multi-color system as developed by Jacobs (see Figure 1.1.7p)
- Inter-Terminal Transit Systems:
 - The Inter-Terminal transit systems (i.e., Skylink = secured area access/elevated tram system; Terminal Link = non-secured area access using curbside shuttles) at DFW will utilize the following colors:
 - Symbol field background = Orange (PMS 166C)
 - Symbol artwork = White
- Parking Garage Level Identification:
 - All parking garage levels will use the same level color-coding as adopted at Terminal A garage:
 - Level 1 = Red (PMS 186C)
 - Level 2 = Purple (PMS 2587C)
 - Level 3 = Yellow (PMS 108C)
 - Level 4 = Orange (PMS 158C)
 - Level 5 = Med. Blue (PMS 2727C)

Other Color Considerations

- Consistent and Holistic Application:
 - To remain effective, the DFW wayfinding color system must always be applied to all wayfinding system elements in a consistent and holistic manner airport-wide (roadways, parking, curbsides, ground transportation areas, terminals, etc.) and at all DFW facilities
- Supplemental Colors:
 - The addition of any/all supplemental colors must always be carefully considered during design of new airport areas and their respective signage design programs in order to determine how they will mesh with the overall established DFW color-coding and wayfinding systems
 - All supplemental colors must be coordinated with/approved by DFW
 - All supplemental colors must always maintain all legibility and compatibility criteria as mentioned in this section, as well as any applicable ADA/Texas ADA and MUTCD/TXDOT requirements regarding color-use on signage
- Additional Use of Color:
 - Certain signs within the airport complex may employ the corporate colors of airlines, rental car agencies, concessionaires and other airport tenants as dictated and/or deemed appropriate by DFW
 - No other colors are to be used for DFW wayfinding signage or sign hardware used within DFW unless otherwise approved by DFW

WARNING:

This record contains Sensitive Security Information that is controlled under 49 CFR parts 15 and 1520. No part of this record may be disclosed to persons with a "need to know," as defined in 49 CFR parts 15 and 1520, except with the written permission of the Administrator of the Transportation Security Administration or the Secretary of Transportation. Unauthorized release may result in civil penalty or other action. For U.S. government agencies, public disclosure is governed by 5 U.S.C. 552 and 49 CFR parts 15 and 1520.

Terminal Areas:

PAINT COLORS

P1 Blue Powder Coated to match 3M 7725-37 EC Sapphire Blue	P2 Silver Matthews Paint # MP30136 Brushed Aluminum, satin finish	P3 Orange (Skylink) To match Pantone 166C. Satin Finish	P4 White Matthews Paint # MP05317 Photopolymer Braille, satin finish	P5 Light Green (Exit) To match Pantone 368C. Satin Finish
P6 Safety Red Matthews Paint to match Pantone 485C, satin fin.				

DIGITAL PRINT COLORS

D1 Light Green (Exit) To match Pantone 368C	D2 Dark Green (Terminal Link) To match Pantone 347C	D3 Reflex Blue (Prearranged Limo) To match Pantone Reflex Blue C	D4 Light Yellow (Taxi) To match Pantone 102C	D5 Orange (Shared Ride) To match Pantone 165C
D6 Aqua (Rental Cars) To match Pantone 299C	D7 Grey (Courtesy Van) To match Pantone 431C	D8 Mustard (Remote Parking) To match Pantone 124C	D9 Red (Express Parking) To match Pantone 704C	D10 Blue (DFW Valet) To match Pantone 301C
D11 Purple (Public Transit) To match Pantone 676C	Note: Typical Non-glare Overlaminated			

VINYL COLORS

V1 Blue 3M™ EC 7725-37 Sapphire Blue	V2 White 3M™ 7725-20 Opaque Matte White	V3 Yellow 3M™ 3630-25 Sunflower	V4 Light Green (Exit) To match Pantone 368C Opaque with Matte finish	V5 Black (Exit / Door Numbers) 3M™ 7725-22 Opaque Matte Black
V6 Safety Red To match Pantone 485C Opaque with Matte finish	V7 White 3M™ 4090 DG3 White	V8 Yellow 3M™ 4091 DG3 Yellow	V9 Blue 3M™ 4095 DG3 Blue	V10 Light Gray To match PMS Cool Gray 1C Opaque with Matte Finish

Garage Areas:

L1 (aka Level 1) Red = PMS 186C	L2 (aka Level 2) Purple = PMS 2587C	L3 (aka Level 3) Yellow = PMS 108C	L4 (aka Level 4) Orange = PMS 158C
L5 (aka Level 5) Blue = PMS 2727C	L6 (aka Level 6) Terminal D Only: White	LL1 (aka Lower Level 1) Terminal D Only: Green = PMS 368C	LL2 (aka Lower Level 2) Terminal D Only: Pink = PMS 204C
P1 Blue TIGER Drylac powder coat #PLSF21528P	V7 White 3M™ 4090 DG3 White	D12 Blue Digital print to match P1	

Curbside/Ground Transportation Areas (2017 New Adopted Jacobs-Developed Color System):

POWDERCOAT COLORS

C1 Blue TIGER Drylac #PLSF21528P	C2 Silver Metallic TIGER Drylac #38/31020	C3 Blue Powder Coated to match
--	---	---

PAINT COLORS

P1 Blue Matthews Acrylic Polyurethane Match Pantone 287C	P2 Silver Metallic Matthews Acrylic Polyurethane MP30136 "Brushed Aluminum"
--	---

DIGITAL PRINT COLORS

UL1 Pantone Reflex Blue C	LL1 Pantone Cool Gray 10	LL6 Pantone 287 CP
UL2 Pantone 166 CP	LL2 Pantone 5265 CP	LL7 Pantone 347 CP
UL3 Pantone 102 C	LL3 Pantone 631 CP	LL8 Pantone 676 C
UL4 Pantone 347 CP	LL4 Pantone P 88-8C	
UL5 Pantone 704 CP	LL5 Pantone 130 CP	

VINYL COLORS

V1 3M EC 7725-37 Sapphire Blue	V5 3M EC 7725-15 Bright Yellow	V9 ARLON 2100-42 Cardinal Red
V2 3M EC 7725-77 Peacock Blue	V6 ARLON 2100-58 Dark Magenta	
V3 3M EC 7725-14 Bright Orange	V7 3M EC 7725-186 Bright Green	
V4 3M EC 7725-38 Royal Purple	V8 3M EC 7725-64 Apricot	

GROUND TRANSPORTATION COLORS/SYMBOLS APPLIED

Terminal Link Background: PMS 166C Symbol: PMS166C/White	Pre-Arranged Limo Background: PMS Reflex Blue C Symbol: PMS Reflex Blue C/White	Taxi Background: PMS 102C Symbol: PMS 102C/Black
Rental Cars Background: PMS 5265C Symbol: PMS 301C/White	Courtesy Vans Background: PMS 254C Symbol: PMS 254C/White	Remote Background: PMS 130C Symbol: PMS 130C/Black
Charter Bus Background: PMS 186 C Symbol: PMS 186 C/White	Passenger Pick Up & Drop Off Background: PMS 347C Symbol: PMS 347C/White	Express Background: PMS 631C Symbol: PMS 631C/White
Shared Ride Background: PMS 704C Symbol: PMS 704C/White	Valet DFW Valet Background: PMS Cool Gray 11C Symbol: PMS 165C/White	On-Demand Limo Background: Neutral Black C Symbol: Neutral Black C/White
Employee Background: PMS Cool Gray 11C Symbol: PMS Cool Gray 11C/White	Rail Background: PMS 662C Symbol: PMS 287C/White	Ride App Background: PMS 7461 C Symbol: PMS 7461 C/White
Off Airport Valet Background: PMS 284 C Symbol: PMS 284 C/White/Neutral Black C	Grand Hyatt Valet Background: PMS 7418 C Symbol: PMS 7418 C/White	Corporate Aviation Background: PMS Cool Gray 11C Symbol: PMS Cool Gray 11C/White

Figure 1.1.7p

DFW Wayfinding Color System

WARNING:

This record contains Sensitive Security Information that is controlled under 49 CFR parts 15 and 1520. No part of this record may be disclosed to persons with a "need to know," as defined in 49 CFR parts 15 and 1520, except with the written permission of the Administrator of the Transportation Security Administration or the Secretary of Transportation. Unauthorized release may result in civil penalty or other action. For U.S. government agencies, public disclosure is governed by 5 U.S.C. 552 and 49 CFR parts 15 and 1520.

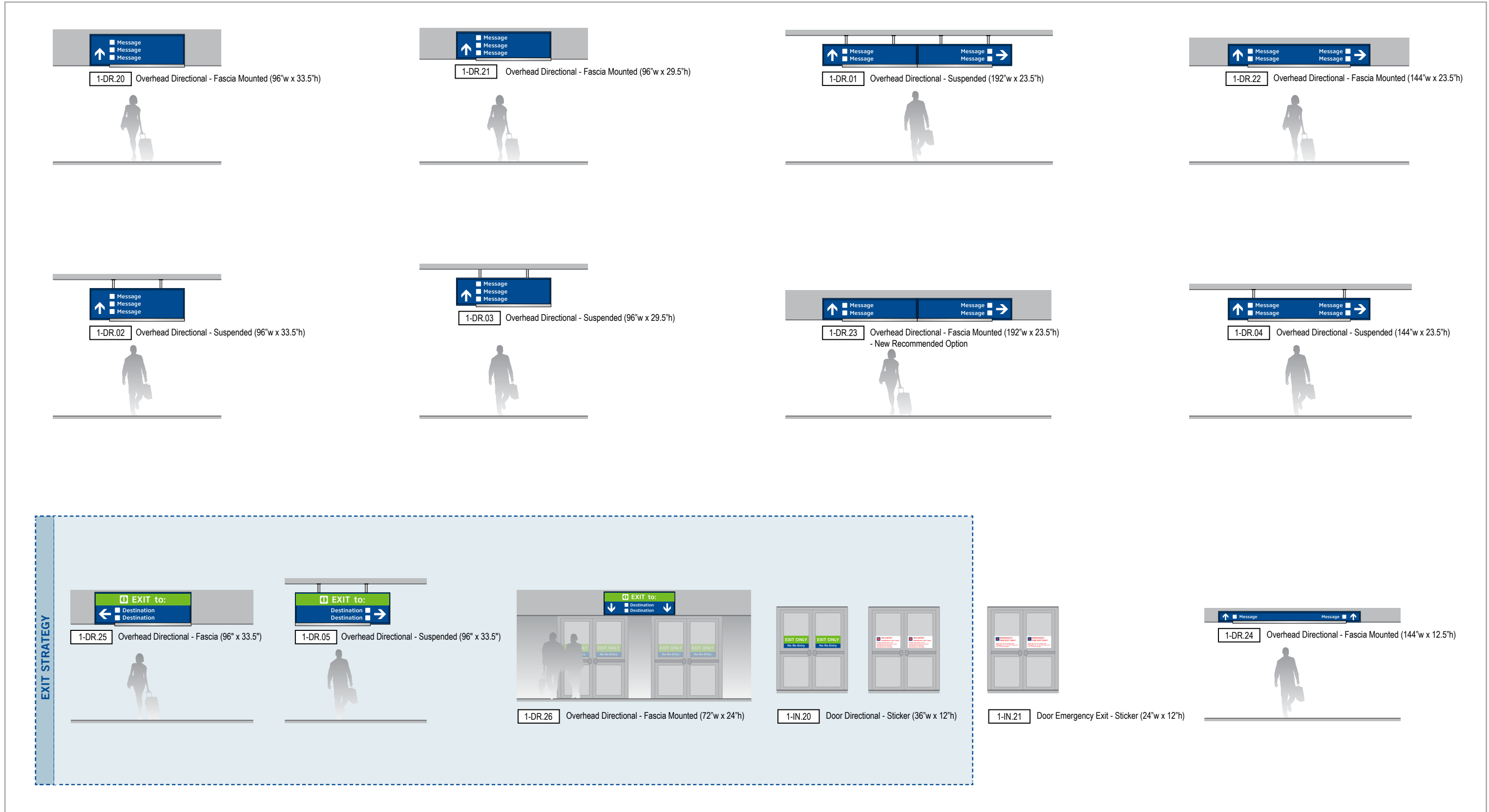

Figure 1.1.8 DFW Wayfinding Sign Family: Terminals/Gate Areas

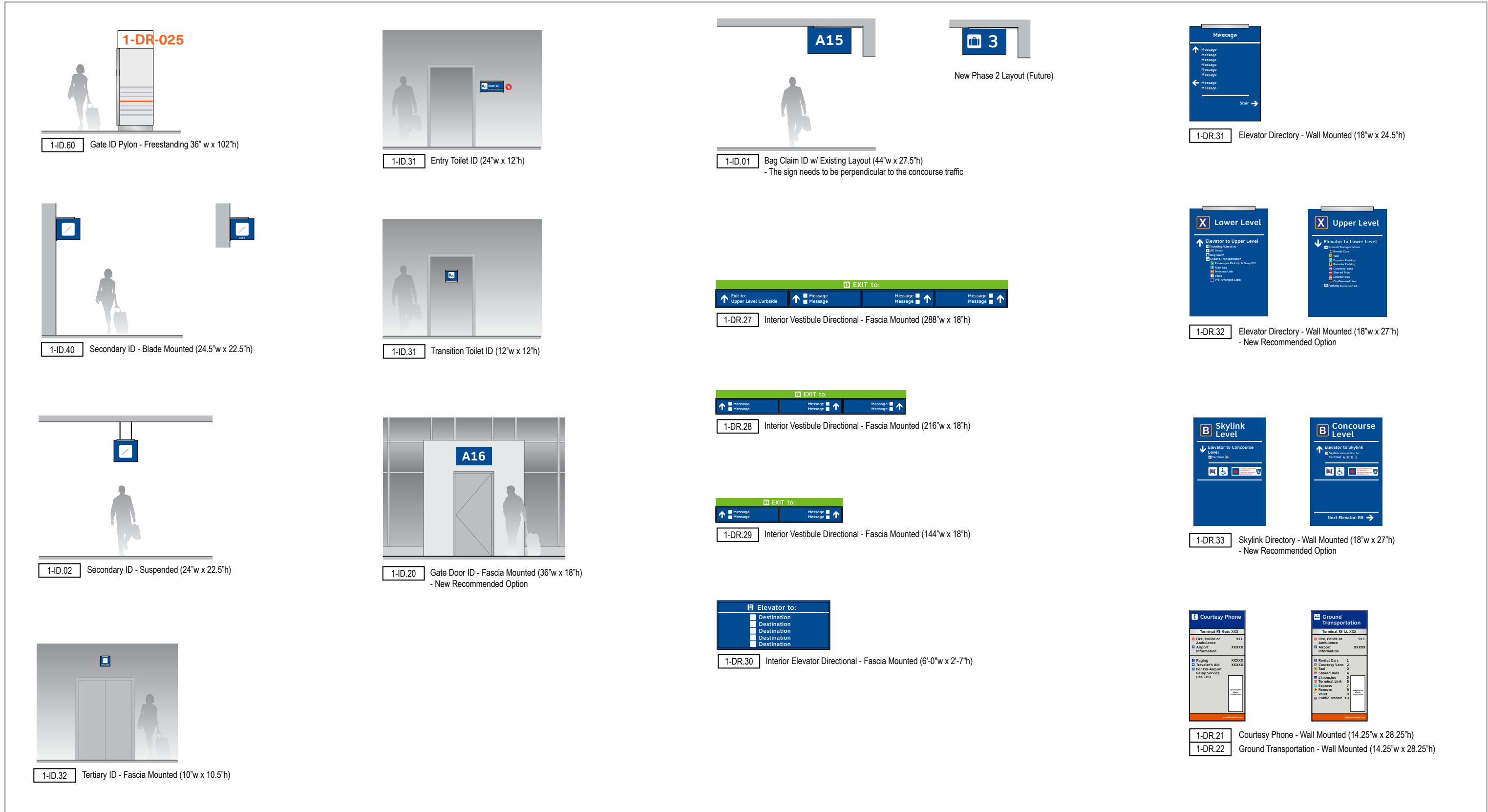

Figure 1.1.8a (cont.) DFW Wayfinding Sign Family: Terminals/Gate Areas (cont.)

TERMINAL A SIGNAGE LOCATION PLAN

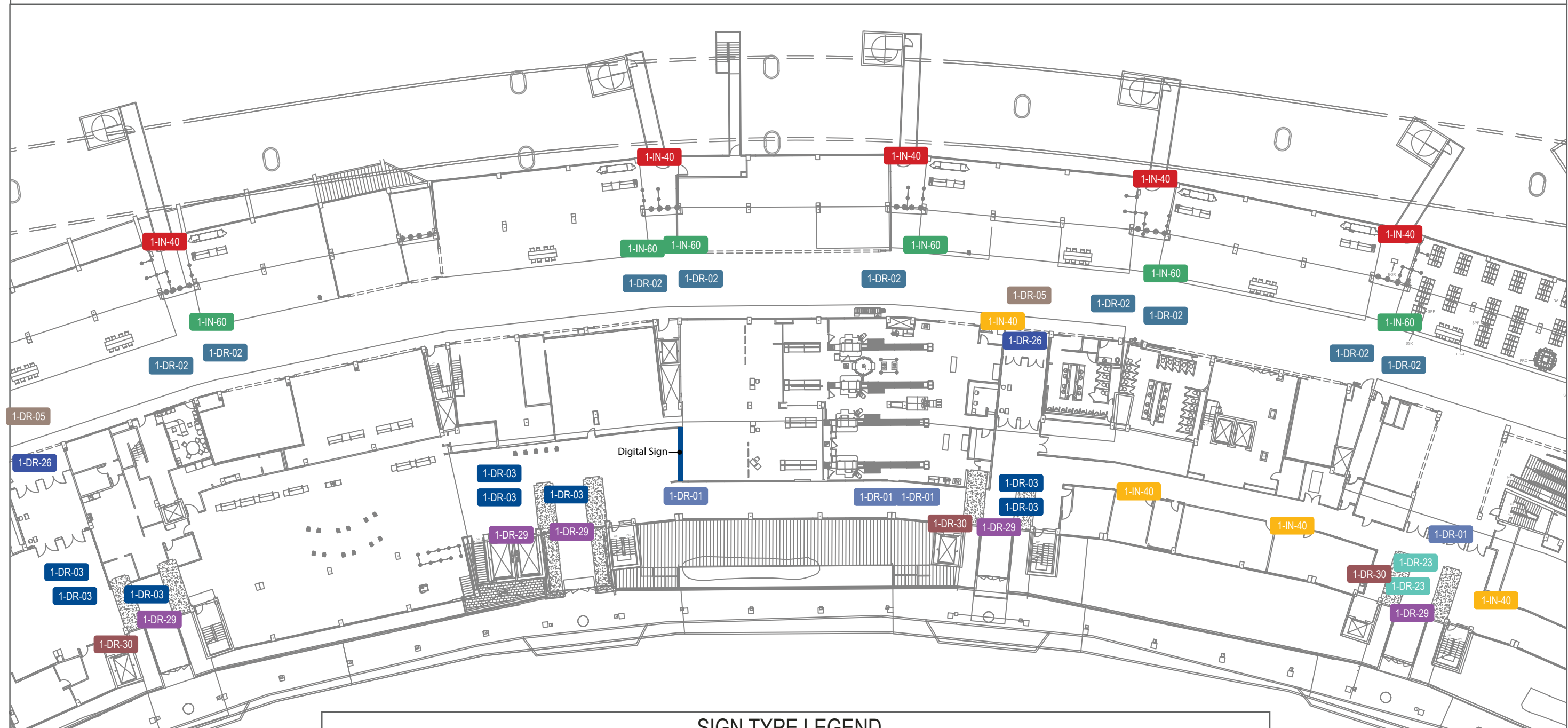

Figure 1.1.8b

DFW Signage Location Plan

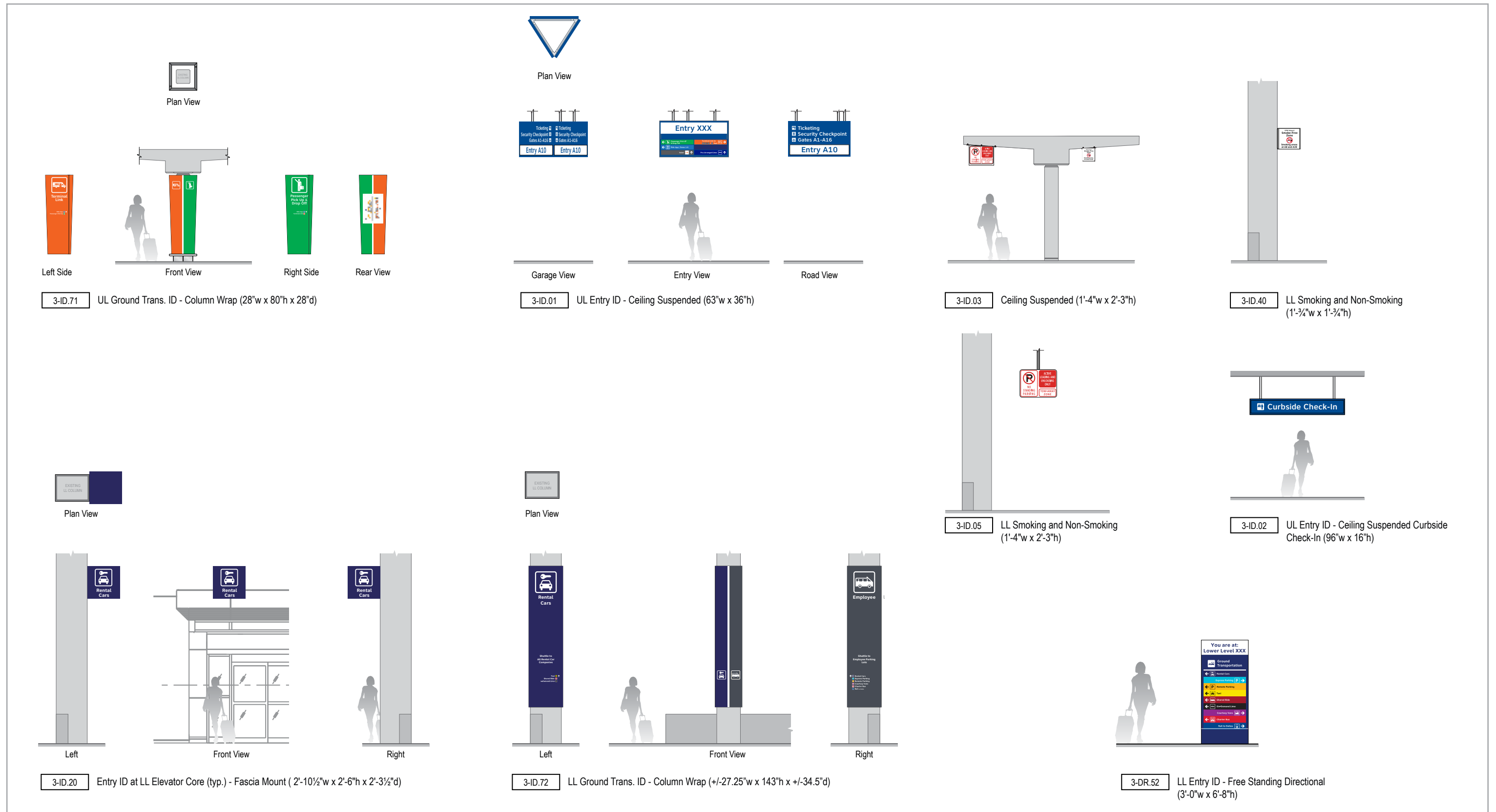
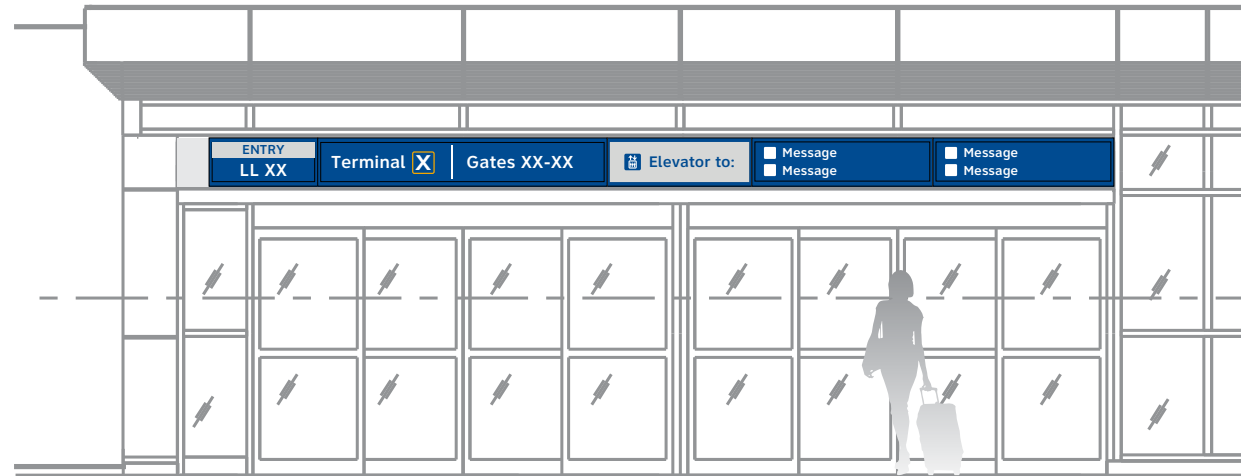

Figure 1.1.8c

DFW Wayfinding Sign Family: **Curbside/Ground Transportation Areas**

WARNING:

This record contains Sensitive Security Information that is controlled under 49 CFR parts 15 and 1520. No part of this record may be disclosed to persons with a "need to know," as defined in 49 CFR parts 15 and 1520, except with the written permission of the Administrator of the Transportation Security Administration or the Secretary of Transportation. Unauthorized release may result in civil penalty or other action. For U.S. government agencies, public disclosure is governed by 5 U.S.C. 552 and 49 CFR parts 15 and 1520.



3-ID.20 Entry ID at LL Elevator Core (typ.) - Fascia Mount (228"w x 16"h)



H.3 Entry ID at LL: variant w/ Elevator/Escalator Trailblazer - Fascia Mount (228"w x 16"h)

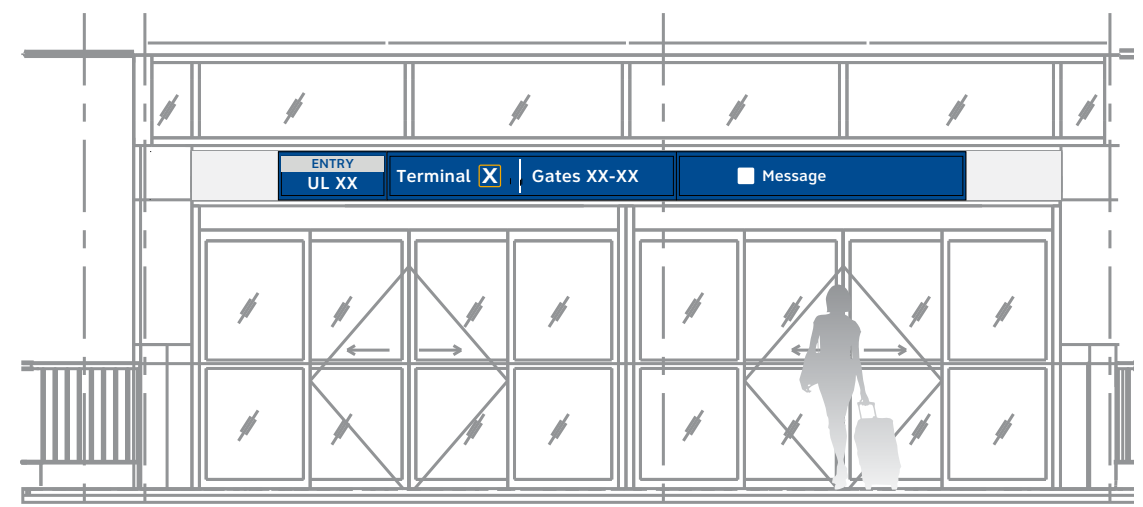

3-ID.21 Entry ID at UL Doors (typ.) - Fascia Mount (228"w x 16"h)



3-ID.21b Entry ID at LL: variant w/ Elevator/Escalator Trailblazer - Fascia Mount (228"w x 16"h)



3-ID.21c Entry ID: variant used at Terminal D - Fascia Mount (228"w x 16"h)

Figure 1.1.8c (cont.) DFW Wayfinding Sign Family: Curbside/Ground Transportation Areas

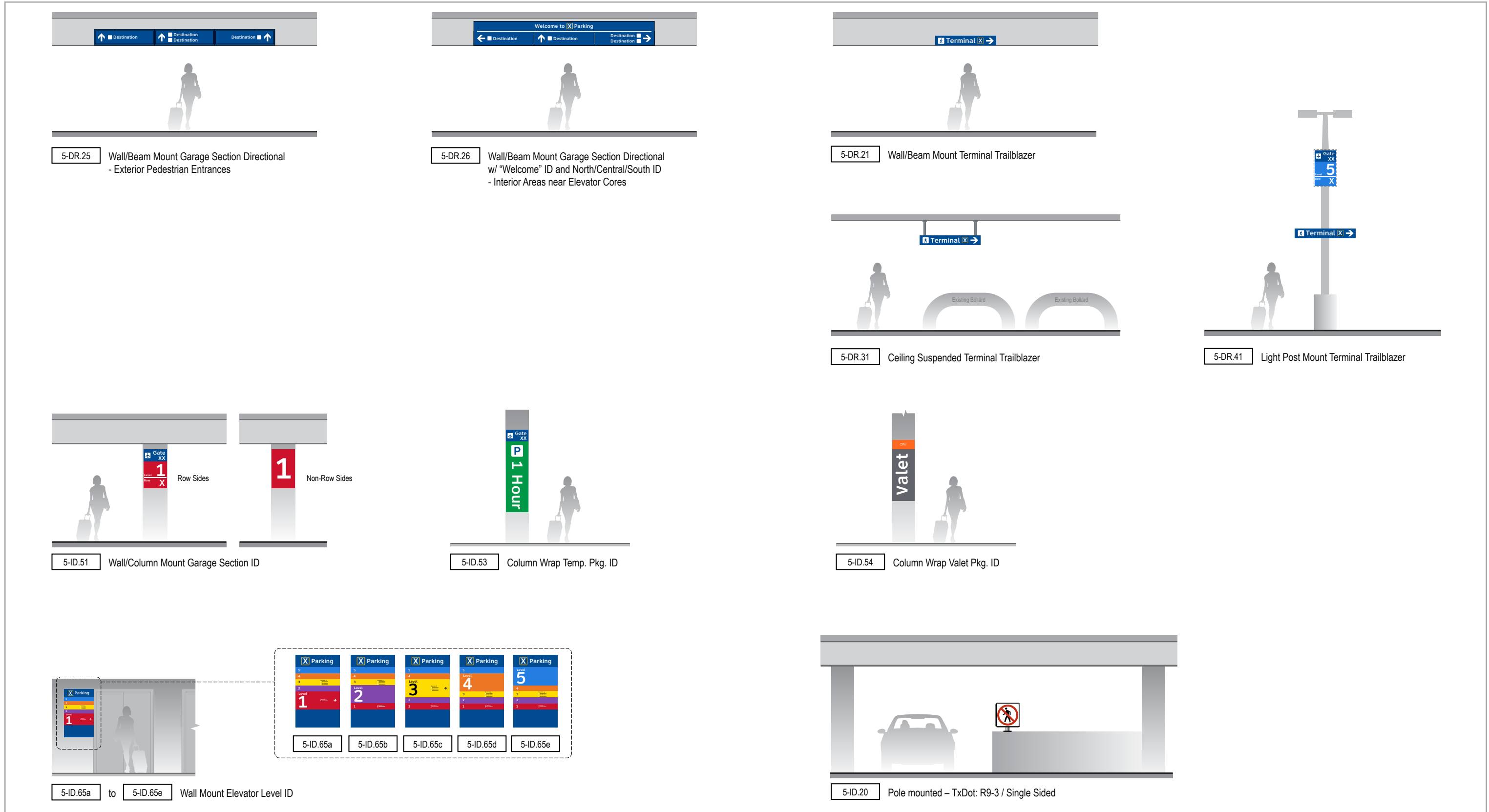
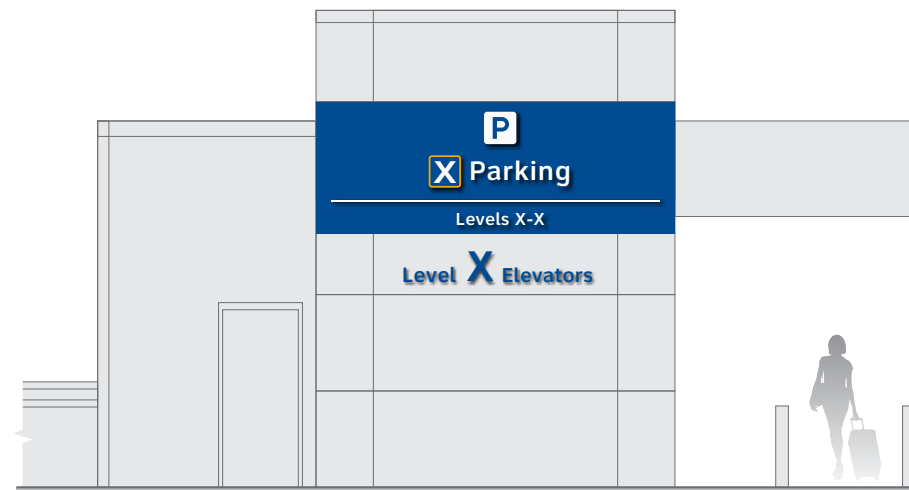

Figure 1.1.8d DFW Wayfinding Sign Family: **Garage/Parking Areas - Pedestrian**



5-ID.55 Wall Mount Large Pedestrian Garage Entrance ID



5-ID.56 Wall Mount Elevator Garage/Level ID

Figure 1.1.8d (cont.)

DFW Wayfinding Sign Family: **Garage/Parking Areas - Pedestrian (cont.)**

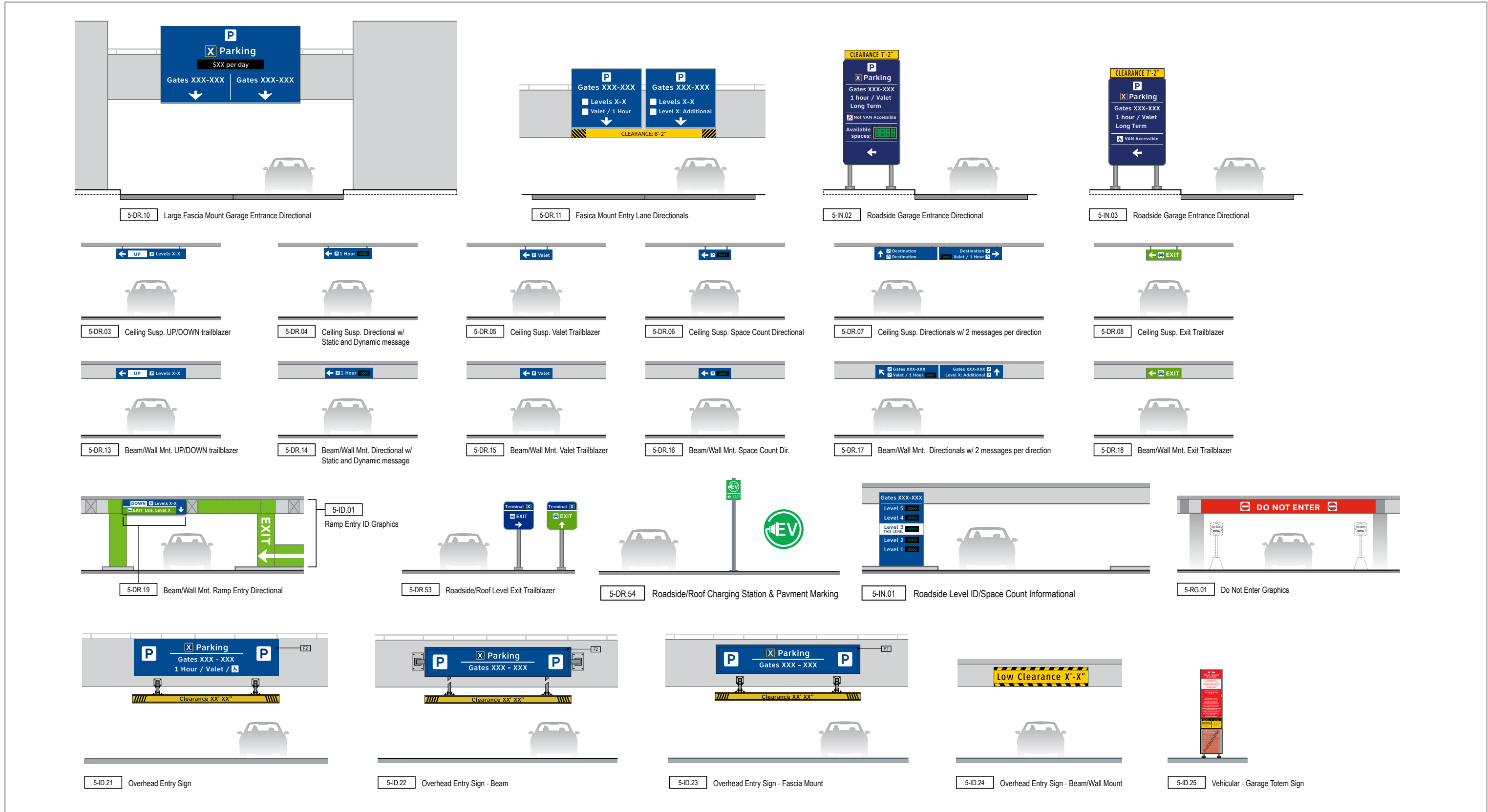
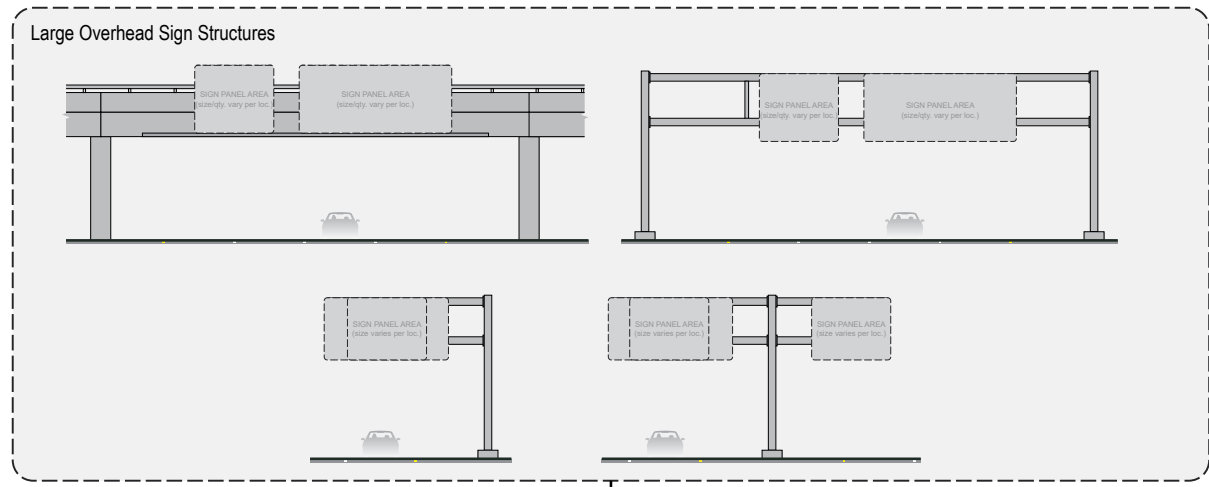

Figure 1.1.8e DFW Wayfinding Sign Family: Garage/Parking Areas - Vehicular



***NOTE:**
 Typical Sign Panel & Support Structure Examples Only
 Sign panels and support structures shown here are for typical example purposes only and are provided as a general design reference for as-built DFW Roadway signage; for additional information/sign panel layouts/structure details/etc, see existing as-built documents

*Typical Sign Panel Examples

RECOMMENDED

4-DR.01 Overhead 1-Lane Directional Panel (15'-0" w x 14'-0" h)

4-DR.06 Overhead Directional Mileage Panel w/ Exit Header (22'-0" w x 12'-0" h)

4-DR.02 Overhead 1-Lane Directional Panel w/ Dynamic Area (17'-0" w x 14'-0" h)

4-DR.11 Overhead 1-Lane 3-Line Directional Panel w/ Exit Header (23'-0" w x 18'-0" h)

4-DR.05 Overhead Cash/Credit Directional Panel w/ Exit Header (18'-0" w x 12'-0" h)

4-DR.12 Overhead 2-Lane 3-Line Directional Panel w/ Exit Header (27'-0" w x 18'-0" h)

S-NB-1 Vehicular Directional Panel - Cantilever (22'-0" w x 9'-6" h)

S-NB-2 Vehicular Directional Panel - Three Line Terminal (27'-0" w x 16'-6" h)

S-NB-3 Vehicular Directional Panel - Two Line Terminal (27'-0" w x 14'-0" h)

Figure 1.1.8f

DFW Wayfinding Sign Family: **Roadway Areas**

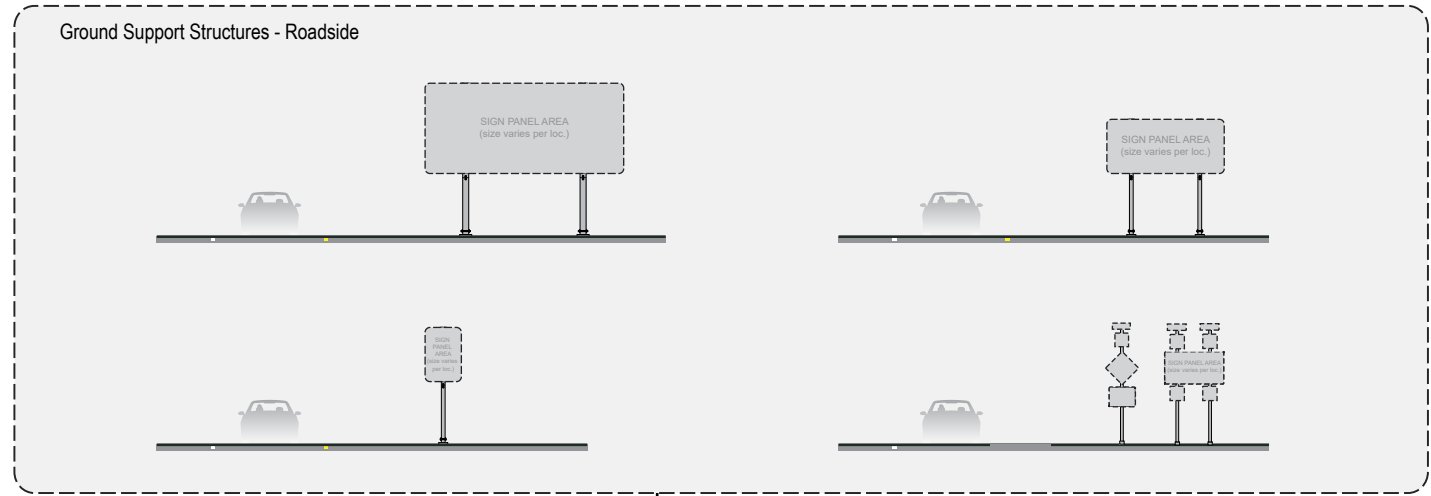

***NOTE:**
 Typical Sign Panel & Support Structure Examples Only
 Sign panels and support structures shown here are for typical example purposes only and are provided as a general design reference for as-built DFW Roadway signage; for additional information/sign panel layouts/structure details/etc, see existing as-built documents

*Typical Sign Panel Examples

RECOMMENDED

4-DR.30 Roadside Exit Trailblazer Panel (15'-0" w x 10'-0" h)

4-DR.31 Roadside Exit Trailblazer Panel w/ Lane Queue Areas (15'-0" w x 12'-0" h)

4-DR.35 Large Roadside 1-Lane 3-Line Directional Panel w/ Exit Header (23'-0" w x 18'-0" h)



S-SB-10 Vehicular Directional Panel - Roadside (13'-0" w x 6'-0" h)



S-NB-11 Vehicular Directional Panel - Roadside (12'-0" w x 6'-0" h)



C-11-GM04 Vehicular Directional Panel - Roadside (18'-6" w x 2'-6" h)



C-12-GM03 Vehicular Directional Panel - Roadside (16'-0" w x 8'-0" h)



C-14-GM02 Vehicular Directional Panel - Roadside (10'-6" w x 8'-6" h)



S-NB-7 Vehicular Directional Panel - Roadside (4'-0" w x 4'-0" h)



IT-NB-22 Vehicular Directional Panel - Roadside (3'-0" w x 5'-0" h)

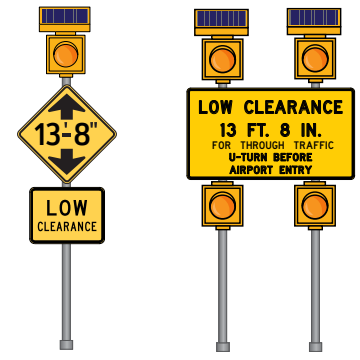

C-14-GM02 Vehicular Int. Prkwy TxDOT Standard Signs - Pole Mount

Figure 1.1.8f (cont.)

DFW Wayfinding Sign Family: **Roadway Areas**

1.1.9 GOVERNING BODIES, CODES & REGULATIONS

Governing bodies, codes, city ordinances and standards affecting the DFW wayfinding and signage system are outlined in this section. The accompanying lists have been compiled from various entities and codes affecting DFW, however, it is not to be considered a complete or final list of requirements. These lists have been initially established by DFW, and changes will be coordinated with and approved by DFW as required on an individual case-by-case basis. If there is a conflict between a requirement listed here and another authoritative code or standard, the more stringent one shall be applied.

NOTE: This section is for general reference only. It is the responsibility of the designer/fabricator/installer to always design/fabricate/engineer/install all signage to meet or exceed all current applicable local, state and national codes and regulations.

General Requirements

- An eggshell or satin finish (11 to 19 degree gloss on 60 degree gloss meter) on sign faces and elements is to be used in order to eliminate distracting levels of sheen.
- Letters and numbers on signs shall have a width-to-height ratio between 3:5 and 1:1 and a stroke-width-to-height ratio between 1:5 and 1:10.
- Characters and numbers on signs shall be sized according to the viewing distance from which they are to be read unless otherwise noted. The minimum height is measured using a capital letter height, and is shown as an "X" for the basis of measurement reference.
- For all tactile signs, the physical sign surface, background finish, contrast, materials, mounting heights/locations, letters/numbers and Braille shall be sized, spaced and applied to meet the most recent Federal ADA standards for Accessible Design, Texas Accessibility Standards and/or other local requirements.
- Elements and spaces of accessible facilities which shall be identified by the "International Symbol of Accessibility" are:
 - Parking spaces designated as reserved for individuals with disabilities
 - Accessible passenger loading zones
 - Accessible entrances when not all are accessible (inaccessible entrances shall have directional signs indicating the route to the nearest accessible entrance)
 - When older facilities contain non-accessible elevators and/or restrooms, the accessible elevators and restrooms must be identified as such
 - All other requirements as dictated by local, state and national standards/building codes and regulations

Governing Bodies & Authoritative Organizations

The following list includes (but may not be limited to) the governing bodies and authoritative organizations as applicable to design and engineering at DFW:

- AAEE: American Association of Airport Executives
- AASHTO: American Association of State Highway & Transportation Officials
- ACC: Airport Consultants Council
- ACRP: Airport Cooperative Research Program: Report 52
- AIGA: American Institute of Graphic Arts
- ANSI: American National Standards Institute
- ASTM: American Society for Testing and Materials
- ATA: Air Transport Association of America
- AWI: Architectural Woodwork Institute
- CAA: Civil Aeronautics Administration
- CAB: Civil Aeronautics Board
- CABO: Council of American Building Officials
- CSI: Construction Specification Institute
- FAA: Federal Aviation Administration
- FHA: Federal Highway Administration
- IATA: International Air Transport Association
- NEMA: National Electric Manufacturers Association
- NFPA: National Fire Protection Association
- TXDOT: Texas Department of Transportation
- Other governing bodies and authoritative organizations as deemed necessary by DFW

Codes & Regulations

The following list includes (but may not be limited to) the governing bodies and authoritative organizations as applicable to design and engineering at DFW:

- ADA: Americans with Disabilities Act
- ANSI: American National Standards Institute
- IBC: International Building Code
- LSC: Life Safety Code (written by the NFPA)
- NEC: No Exposure Certification
- SPC: Standard Plumbing Code (written by the NFPA)
- SBCCI: Standard Building Code
- TDLR: Texas Department of Licensing and Regulation
- UBC: Uniform Building Code
- Other codes and regulations as deemed necessary by DFW

DESIGN INTENT: DEFINITION & LIMITATIONS OF THIS DOCUMENT

Labozan Associates, Inc. (LAI) creates design intent documentation/specifications for the purposes of illustrating new wayfinding signage system design intent only, as it relates to the applicable wayfinding project and its predefined area of scope. LAI is not responsible or liable in any regard for final engineering, material selection, fabrication, installation or performance specification of any kind. The included design intent documentation and specifications are based on the most recent information and drawings as provided to LAI by DFW and the Project Team at the time of publication. Any included drawings, specifications or information within LAI's design intent documentation is to only be used as a general guideline. No information contained within LAI's design intent documentation or specifications should be construed as engineered elements or used for the purposes of final sign fabrication, specification or installation. The Fabricator/Contractor/Installer is responsible for all final design, engineering, fabrication and material specifications with regard to all structural, electrical, mechanical, foundation, installation and material selection/processes, and must be approved by DFW prior to final fabrication/install. In addition:

- All final design, engineering and amount/sizing of structural sign support elements, material types/thicknesses, dimensions, welds and attachment methods shall be performed and approved by an engineer licensed in the State of Texas to meet or exceed all applicable local, state and national codes, standards and regulations. Where a conflict occurs between LAI's design intent documentation/specifications, the more stringent requirements per all codes apply
- Final engineering, dimensions, materials and fabrication are the responsibility of the Contractor/Fabricator/Installer, and the Contractor/Fabricator/Installer must ensure the highest quality fit and finish for all components of the completed product. All final detailing and specifications are to be provided by the Contractor/Fabricator/Installer within their final fabrication-ready shop drawings and must be approved by DFW prior to final fabrication and installation
- Wherever dissimilar metals or possibly corrosive installation surfaces are in contact, always separate contact surfaces prior to assembly or installation with the necessary protective coatings/gaskets/washers to prevent galvanic, moisture related and all other types of corrosion
- Final fabrication methods, materials, quality and fit/finish to be reviewed and approved by DFW through prototype reviews and testing prior to final fabrication production run/installation processes
- Colors shown are for reference only, and are subject to the limitations of the printing process and/or variance of electronic screen displays. Refer to color system swatches and/or final finish samples for accurate reference
- All messages shown in this document must be reviewed by the Contractor/Fabricator/Installer prior to final fabrication and installation (see message schedules for actual messaging by individual location and sign type). Any discrepancies will be identified, documented, corrected and coordinated with DFW during the C.A. process and prior to final fabrication and installation

WARNING:

This record contains Sensitive Security Information that is controlled under 49 CFR parts 15 and 1520. No part of this record may be disclosed to persons with a "need to know," as defined in 49 CFR parts 15 and 1520, except with the written permission of the Administrator of the Transportation Security Administration or the Secretary of Transportation. Unauthorized release may result in civil penalty or other action. For U.S. government agencies, public disclosure is governed by 5 U.S.C. 552 and 49 CFR parts 15 and 1520.

- Sign locations/orientations and plans shown are approximations based on the most current plan drawings as provided to LAI at the time of the document's completion. Sign locations are for general design intent and wayfinding planning purposes only. They should not be construed or deemed as absolute or final locations. Field verification, marking and documentation of every final location is to be performed by the Contractor/Fabricator/Installer and coordinated with DFW for final approval
- All final install locations must be marked and verified in the field for proper structural integrity, adequate line of sight, utilities/property-line/other existing or future interferences, and must be in complete compliance with all local, state and national codes prior to fabrication or installation
- Adjustments to sign locations shown must be documented by the Contractor/Fabricator/Installer and provided to DFW for final approval
- Demolition plans of existing wayfinding signage is not in scope nor included; survey, removal and/or relocation of existing signage is to be coordinated by the Contractor/Fabricator/Installer with DFW

WARNING:

This record contains Sensitive Security Information that is controlled under 49 CFR parts 15 and 1520. No part of this record may be disclosed to persons with a "need to know," as defined in 49 CFR parts 15 and 1520, except with the written permission of the Administrator of the Transportation Security Administration or the Secretary of Transportation. Unauthorized release may result in civil penalty or other action. For U.S. government agencies, public disclosure is governed by 5 U.S.C. 552 and 49 CFR parts 15 and 1520.

1.1.10 CHANGE PROCEDURES/SIGN REPLACEMENT

Sign Replacement/Ordering Procedures

To ensure that the guidelines shown in this document are adhered to and signage is holistically maintained at all times, designers and individuals specifying signage for use within the DFW Airport complex will be required to use the sign replacement/ordering procedures as established by DFW.

All proposals for new construction or alteration of signs shall be required to follow one of the two established review procedure packages as follows:

1. Large Scale: New Construction, which includes:
 - New large scale design/construction projects/programs
 - New large scale interim/temporary sign projects/programs
2. Small Scale: Sign Additions and Corrections, which includes:
 - General sign maintenance
 - Arrival of new airlines
 - Airline Relocation
 - Addition of a sign
 - Deletion of a sign
 - Implementation of a temporary sign/banners
 - Miscellaneous sign issues

Management and Control

- Permanent and temporary signage programs shall fall under the same management process relative to review, approval and implementation. The program shall also be controlled through the DFW Planning Department and should include code compliance review where applicable
- A single point of contact shall be established (i.e. the Signage Project Manager)
- This strict process is required to control what is displayed, and how long it is displayed in/around the project area
- New signage shall be evaluated to establish any conflicts with existing permanent signage, wayfinding, concessions, advertising, art and/or other programs
- The construction process and schedule shall be monitored to ensure new wayfinding paths are properly addressed
- The process shall be flexible enough to address and deliver last minute changes and requirements to meet the operational and functional requirements of the project environment

Fabrication and Maintenance

This document is intended to illustrate design intent, and should only be used as a general guideline. No information contained here should be construed as engineered elements. The sign designer/fabricator/contractor shall be responsible for all engineering and specifications with regard to structural, electrical, mechanical, foundation and installation. Detailing and information contained on these pages shall not be reproduced, copied or utilized in any way without previous written authorization from the DFW Planning Department.

As-Built Documentation

As part of any sign related design and installation, complete documentation of the final built condition shall be provided to the owner at the completion of a project. As part of this submission the following drawings shall be included at a minimum:

- Sign location plans that illustrate the accurate placement of each sign. Each individual sign on the drawings shall be given a unique reference sign number
- Sign elevation drawings that illustrate the mounting height of all the sign types. Any variances from the typical mounting heights shall be noted
- Sign fabrication detail drawings that illustrate all of the internal and external components of the signs as well as any means of assembly
- Detailed sign attachment shop drawings that illustrate how the sign is attached to the building or site
- Copies of as-built drawings shall be reviewed and approved by the DFW Planning Department and code compliance prior to submittal and final versions
- Where applicable, the DFW Planning Department shall review as-built drawings for code compliance
- In addition to the As-Built Drawings, a consistent written database of every sign for record and use with the maintenance program should be created. This database should include the following items at a minimum:
 - Sign number (unique and identifiable)
 - Description of sign location (plan, using nearest architectural column-line if applicable)
 - List of physical properties (length, width, height, depth and weight)
 - List of electrical properties: electrical service (V), and amps required (A)
 - Complete parts list with supplier information.
 - Digital photo or artwork for each sign message
 - Maintenance log for the sign including scheduled maintenance tasks

Governance

Governance Process/Policy: The process suggested here reflects only the bare basics of a wayfinding and signage policy for all DFW departments, tenants, concessions, advertising and other on-going programs which could impact the passenger information orientation and decision-making requirements. Control must be from a central point and one department (i.e. DFW Planning Department). Applications for "signage" shall be necessary to begin the process.

- Design shall be submitted to the DFW Planning Department Signage Project Manager
- Design options, when applicable (i.e. illumination options), will be submitted to the Planning Department Signage Project Manager for review, selection, and approval
- Shop drawings shall be submitted to the DFW Planning Department Signage Project Manager prior to fabrication for review and approval
- Prototype signs shall be produced for each sign family type and submitted to the DFW Planning Department Signage Project Manager for review and approval
- DFW Planning Department Signage Project Manager to conduct site visits

and inspections on all signs during associated implementation phase of construction and other DFW signage projects

Reference Materials

The following information can be used as a helpful reference and can be provided by DFW upon approved request:

- Sign Replacement Program for Terminals A, B, C, E TA NO. A04-077B Delivery Order No. Issue for Bid July 30, 2004
- Sign Replacement Program For Terminals A, B, C, E TA NO. A04-077B Delivery Order No. Issue for Bid Sept 13, 2004
- Sign Replacement Program For Terminals A, B, C, E TA NO. A04-077B Delivery Order No. Issue for Bid Sept 13, 2004 Construction Contract # 850195001 TA # A04-077B-007Curbside Reallocation Terminal A,B,C,&E (future approved plans)
- Terminal Carousel Roads Guide Signs TA No. A01-090B-003 100% Submittal (Issue for Construction) April 28, 2003
- Curbside Reallocation Terminal A, B, C, &E (future approved plans)
 - Sign Design Requirements Peer Review Workshop:
 - DFW Airport Wayfinding Signs & Graphic Standards
 - SDR Lessons Learned
 - Signage Issues & Requests
 - Term D Advertising Observations and Recommendations
 - ACRP 07-08 Wayfinding & Signage Guidelines
- DFW Curbside Signage Contract NO. 9500273 (Existing signage)
- Roadway Sign Design Manual
- Terminal D Wayfinding Graphic Criteria Manual

1.2 WAYFINDING ANALYSIS AND APPLICATION

1.2.1 OVERVIEW

Prior to developing updated wayfinding signage design standards, it is fundamental to understand the existing wayfinding signage at DFW. In order to establish a clear direction in which to move forward with the updated wayfinding signage program, LAI analyzed all relevant existing materials by site visits, capturing photographic examples, and reviewing existing and/or planned sign program documentation at each terminal.

Evaluation Criteria

It is important for wayfinding signs to adhere to a basic guideline of copy styles/sizes, maintain consistent terminology, use recognizable and universally accepted symbols, incorporate uniform colors systems, and utilize consistent recognizable sign types. This section covers key elements that impact the effectiveness of a wayfinding signage system, as well as overall wayfinding processes at airports. LAI used these key elements as the criteria by which the existing signage system was evaluated, and will continue to use for implementing new wayfinding signage within DFW construction programs. Note that industry standard wayfinding and signage factors are covered in additional detail within the following documents:

- ACRP Report 52 - Wayfinding and Signing Guidelines for Airport Terminals and Landside – 2011 (<http://www.trb.org/Publications/Blurbs/165910.aspx>)
- Americans with Disabilities Act – 2010 ADA Standards for Accessible Design – Latest Revisions (https://www.ada.gov/2010ADAstandards_index.htm)

The following are general descriptions of the evaluation criteria used for analyzing the DFW wayfinding program:

- Signage Philosophy: Establish an integrated framework that would produce ONE comprehensive, holistic and visually attractive signage system that can be easily understood, followed and identified
- Standard Terminology: Experience the same terms and sign types from one terminal, facility or area to the next, which will assist in rapid public comprehension of various airport functions/destinations. Message content must be in layman’s language, equally understandable by first-time and frequent travelers
- Message Hierarchy: Clear and concise information presented by “primary,” “secondary” and “tertiary” sets of messages greatly improves efficient passenger flow
- Color Coding: Colors have great effect on human behavior and deciphering wayfinding information. Thoughtful consideration and consistent implementation should always be utilized when using multiple colors within a wayfinding sign system
- Symbols: The use of short verbal messages in conjunction with symbols is more effective than the use of messages or symbols alone. The use of consistent graphic representations and sizing of symbols and arrows maintains system cohesion and more rapid information deciphering. Limiting the number of arrows at a given decision point also greatly improves information deciphering and passenger flow

- Scale of Copy: In a fast paced, often congested environment such as an airport, a conservative pedestrian viewing distance of 25 feet of viewing distance to each inch of capital letter height should be used.
- Sign Placement: Placement of signs at key decision points and/or in the direct line of sight of the traveling public reduces decision times. A reasonable range of 75 to 125 feet between major directional overhead signs is acceptable and meets the general intent of ADA guidelines. Using signs at regular intervals within longer contained corridors reinforces wayfinding information and improves traffic flow

Conceptual Wayfinding Plans

Identify conceptual wayfinding pathways, decision points and sign locations for wayfinding signage to be implemented within all DFW construction programs. They will be used only as a general starting point/guideline for initial conceptual sign location reference within each applicable improvement program. More finalized and exact locations will be implemented during design development processes, and coordinated with DFW.

Interim (Temporary) Wayfinding

In addition to the established DFW wayfinding signage system, a transitional sign system should also be developed and employed during interim wayfinding conditions. A conceptual transitional wayfinding sign family should be considered and developed by designers during design phases as needed.

The following are recommendations for an effective transitional wayfinding signage system:

- A stand-alone or supplemental graphic/wayfinding “roll-out” campaign
- Emphasis on highly visible transitional signage that matches the general design/graphic intent of the final permanent signage
- Fabrication, installation and revision time should be very fast/expedited
- Easy on-site and “on-the-fly” revisions and sign adjustments
- Educates users with the new wayfinding program’s graphics, shapes, terminology, etc.
- Allows time to properly study, evaluate and address the most effective permanent wayfinding signage locations and solutions, while not compromising passenger circulation efficiency
- Timeframe on how long transitional wayfinding systems are in place should be established by phasing plans
- Fabrication considerations:
 - Constructed of low-cost materials to last the duration of the transitional period
 - Light-weight inexpensive sign face/background materials
 - Gatorfoam, Sintra, MDO plywood, etc.
 - Graphics = first surface applied digitally cut vinyl, or full-bleed (edge-to-edge) graphics printed on surface applied vinyl
 - Temporary printed sign face cover-wraps to cover permanent signage with transitional messaging/graphics
 - Banner materials
 - Over-the-face (wrap) configurations

- Temporary surface applied vinyl “super-graphics”
 - Draw additional attention to important vertical and/or horizontal travel areas and destinations; to be seen from greater distances for earlier queuing
- Freestanding moveable sign base systems
 - Gatorfoam with aluminum clamp bases
 - Pre-fabricated (off-the-shelf) units with slide-in graphic panel areas
- Implementation phasing based on DFW modernization program scheduling (TBD by others and coordinated with DFW)

Final Wayfinding Plans and Signage Design Intent

The wayfinding plans shown in this document are conceptual only and are based on the most recent architectural files as provided to LAI by the Project Team at time of this document’s publication. The sign family shown in this document is also considered in development and may require further refinement and/or additional sign types as deemed necessary during future design development processes. Final wayfinding plans, sign location plans and signage design intent drawings will all be further developed and refined during the course of DFW construction programs.

1.3 DESIGN CRITERIA

1.3.1 OVERVIEW

The general design criteria for DFW Airport's wayfinding sign program is organized into sections which outline the procedures and requirements for development of a holistic DFW wayfinding system. This criteria will help guide designers, fabricators and installers when implementing wayfinding signage at DFW Airport. Note that this section shall be used as the general basis for, and in supplement to, Chapter 2.0 *Wayfinding Graphic Standards & Guidelines*

The following list of design requirements/criteria shall be applied to all wayfinding sign types:

- Methodology
- Nomenclature
- Message Hierarchy
- Graphic Standards
- Sign Types

Methodology

To establish a comprehensive means of understanding DFW Airport's existing wayfinding sign system, an in-depth analysis of the facilities and circulation was conducted and published within the DFW Wayfinding Observations and Recommendations. All public-use landside Airport facilities and areas were reviewed and analyzed in a summarized format in order to understand and document existing wayfinding conditions, as well as provide analysis. The following were reviewed and analyzed:

- All applicable DFW Airport facilities plans (floor plans and elevations)
- Space functions
- Circulation paths
- Peak load circulation
- Nomenclature
- Message Hierarchy
- Vertical and horizontal circulation
- Primary destinations
- Possible areas that may prohibit efficient passenger circulation

Nomenclature

The first issue addressed was the establishment of Airport nomenclature. Nomenclature issues were addressed by identifying areas with inconsistent terminology use, and/or terminology that was not common practice in the airport industry. In coordination with DFW, terminology identifying DFW Airport functions and space were established and standardized.

Message Hierarchy

Upon establishment of standardized DFW Airport nomenclature, a message hierarchy was established. Hierarchy of messages were created for primary, secondary, and tertiary messaging. Ranking is based on routing of destination priorities and site or space specific direction(s). See *Section 2.1 Messages* for more detailed information regarding acceptable message hierarchy use at DFW Airport.

Nomenclature and message hierarchy shall be specifically tailored for the following wayfinding sign types categories:

- Directional: signs that display standardized directional messaging to assist in finding one's way through a defined area or environment (i.e. an overhead sign at a decision point with arrow/symbol/destination messages listed)
- Identification: signs used as unique markers to identify specific locations within a defined area or environment (i.e. a gate identification sign)
- Informational: signs or graphic systems that display specific and very detailed information to assist in orientation within a complex or unfamiliar environment (i.e. a directory map or FIDS)
- Regulatory: signs that display regulatory, safety or local code information (i.e., "No Parking" or "Loading Zone Only" signs)

Graphic Standards

Once DFW Airport's wayfinding methodology and system were determined, graphic standards were developed and established (see Chapter 2.0 *Wayfinding Graphic Standards & Guidelines*). Included within these graphic standards are:

- Typography, including Type Spacing and Legibility (See 2.2 *Typography*)
- Symbols (See 2.3 *Symbols*)
- Arrows, including application (See 2.4 *Arrows*)
- Colors (See 2.5 *Colors*)
- General material considerations

Sign Types

DFW Airport's wayfinding system uses a comprehensive set of sign types. It has been developed into a holistic family of signs with each member having their own specific use and purpose, while also utilizing a "kit-of-parts" design philosophy. It is designed to be manageable, integrated in a seamless manner with DFW Airport's Terminals/Gates areas, and can be updated on a continuing basis as needs arise.

Note that the wayfinding sign family at DFW Airport will always be categorized as directional, identification, informational and regulatory sign types. These sign types are listed as a catalog within *Chapter 4.0 - Sign Types*. It is a tool to assist designers in programming wayfinding signage, and establishes an effective design process when creating signage for inclusion within DFW's wayfinding system.

Note the following considerations used during the development of DFW's wayfinding sign family:

- Consideration of synchronicity with architecture and/or built environments. Analysis of architectural/environmental/site/location palettes, finishes, textures and shapes to allow wayfinding signage that complements its surroundings
- Multiple size and placement options developed for all sign types. Conditions Airport-wide were addressed with signage applications established for all facilities (i.e. directional signs may require applications for various configurations, including overhead, wall mount, blade mount, etc)
- Research of materials, finishes, textures, and colors appropriate for architectural/environmental/site/location requirements
- Documented specifications for signage materials, as well as fabrication and installation 1-38 techniques. By providing details and in-depth sign specifications, highly competitive and accurate bid solicitation is possible

WARNING:

This record contains Sensitive Security Information that is controlled under 49 CFR parts 15 and 1520. No part of this record may be disclosed to persons with a "need to know," as defined in 49 CFR parts 15 and 1520, except with the written permission of the Administrator of the Transportation Security Administration or the Secretary of Transportation. Unauthorized release may result in civil penalty or other action. For U.S. government agencies, public disclosure is governed by 5 U.S.C. 552 and 49 CFR parts 15 and 1520.

2.0

2.0 WAYFINDING GRAPHIC STANDARDS & GUIDELINES

- 2.1 Messages
- 2.2 Typography
- 2.3 Symbols
- 2.4 Arrows
- 2.5 Colors
- 2.6 Art, Advertising and Amenities
- 2.7 Illumination
- 2.8 Wayfinding Sign System Overview

2.1 MESSAGES

2.1.1 OVERVIEW AND FUNCTIONS

This section defines the four basic functions of a “message” as it pertains to the DFW wayfinding system. It is to be utilized by anyone designing or specifying new or updated wayfinding signage to be implemented at DFW.

- Directional Messages
- Identification Messages
- Informational Messages
- Regulatory Messages
- Life-Safety/Egress Messages
- Temporary Messages

Directional Messages

The main source of information enabling wayfinding traffic to choose the proper route to a specific destination point. This process involves selecting the correct destination point, and then determining at which point a change of direction will be required. Properly placed directional signage at decision points in adequate quantities is necessary for rapid movement of passengers, employees and vehicles.

Identification Messages

Mark specific locations/destinations within a defined area or environment. In addition to these locations, identification messages provide proper public exposure to leased tenant spaces and other spaces as governed by Airport Management.

Informational Messages

Provide specific, detailed and supplementary wayfinding information to assist in orientation within an unfamiliar and/or complex environment. In addition, informational messaging that is graphic in nature (i.e. directory maps) help with providing precise locations for the user in context to the overall facility and its destinations/amenities/etc.

Regulatory

Relate to DPS, FAA, TSA and CBP requirements, as well as other federal, state, and local city codes/regulations. In general, these messages provide travelers with important regulatory information, such as travel advice, warnings and restrictions.

Life-Safety/Egress

Signs that display life-safety and vertical circulation/ egress related information as required by local and national codes (i.e. fire escape stairway core level identification signs).

Temporary Messages

Temporary Messages generally fall into a separate category of messages, and are typically established during the course of fluctuating interim wayfinding conditions due to construction related processes. Temporary signs shall only be used on an interim basis while permanent signs are in the process of fabrication, repair and/or maintenance. Temporary signs are also an excellent way to test new wayfinding elements and locations prior to final fabrication. Note that all temporary messages shall be reviewed and approved by the DFW Planning Department prior to implementation.

2.1.2 MESSAGE HIERARCHY

This section defines standards for a complete and uniform hierarchy of DFW wayfinding system messages and terminology. These standards shall be utilized for all new and updated wayfinding signage implemented at DFW Airport.

The need for visual continuity among all messages and information of the same hierarchy will help eliminate elements which may interrupt the functional wayfinding process or add confusion. Clear and concise information presented by primary and secondary signs/messaging systems ensure efficient passenger circulation. Tertiary signs/messaging must always be coordinated with primary and secondary signs/messaging, as well as interior design features and elements. This tertiary category of signs should also always be visually distinguished from other wayfinding signs.

Messages will always be organized and maintained within three distinct and functionally tiered categories: Primary, secondary and tertiary (see Figure 2.1.1 for full message hierarchy lists categorized by airport area usage).

Primary Messages

This information shall be the largest and the most visible information on each sign. Primary information includes, but may not be limited to:

- Exterior direction to and identification of Terminal(s)
- Exterior direction to major vehicular arteries (i.e. nearby access roads).
- Interior direction to and identification of multiple Terminals if applicable (i.e. A, B, C, D, E) and inter-terminal transit (i.e. Skylink and Terminal Link)
- Interior direction to and identification of Gates
- Interior direction to and identification of Bag Claim and Ticketing/Check-In

Secondary Messages

This information supplements and reinforces information already conveyed by the primary messages and signs listed above. It usually indicates the auxiliary services and support functions of the facility. Secondary information includes, but may not be limited to:

- Exterior direction to and identification of Ticketing/Check-In, Bag Claim, and specific Parking Facilities/Areas
- Exterior identification of Rental Car Return, Airport Exit, etc.
- Interior direction to and identification of Elevators and Restrooms
- Interior direction to Parking and Ground Transportation

Tertiary Messages

Tertiary sign information supplements both the primary and secondary messages, and typically informs visitors of regulations and warnings. All regulatory/safety signs are generally considered to be tertiary within the DFW wayfinding system. Tertiary information includes, but may not be limited to:

- Exterior and Interior TSA related notification messages.
- Interior CBP related notification messages
- Exterior “No Parking” messages
- FAA required warnings, notifications and information
- Other messages required by code

2.1.3 MESSAGE TERMINOLOGY

Basic Requirements

Terminology, or nomenclature as it applies to airport signage and wayfinding systems, is a standardized set of words, syntax, grammar, spelling, and symbols used to communicate information to the user of the airport. Terminology systems ensure that information is presented in a consistent way, and that the content of this information is always clear and concise. When a term is shown with a corresponding symbol, that term will always appear with its symbol as indicated in *Section 2.3 Symbols*, unless otherwise noted.

Change Procedures for Terminology

Consistent use of terminology for established messaging within the DFW wayfinding system is always required. All changes to or additions of new terminology shall require coordination, review and approval by the DFW Planning Department.

FOREIGN LANGUAGE: APPLICATION & USE

Universal Symbols

Using universal symbols will assist international and non-English speaking travelers with locating airport destinations in a universal manner, while also eliminating the possibility of unintended bias for individual groups and languages. See *Section 2.3 Symbols*.

Informational Wayfinding Signage and Supplemental Materials

Accommodating multiple languages on informational wayfinding signage (i.e. directories and information centers), as well as supplemental materials (such as hand-outs and maps) is the recommended and preferred method of providing detailed wayfinding information to the most diverse groups of non-English speaking airport users. Standards and guidelines for this type of information are not covered within this document and is to be coordinated with the DFW Planning Department as applicable and required.

Foreign Language Translations

All foreign language translations, if/when used within the DFW wayfinding system, are to be provided by professional translators and will be coordinated with DFW staff for final approval prior to final fabrication and installation. All foreign language translations will use the most common and universal dialect for each individual foreign language as deemed appropriate by professional translators.

WARNING:

This record contains Sensitive Security Information that is controlled under 49 CFR parts 15 and 1520. No part of this record may be disclosed to persons with a "need to know," as defined in 49 CFR parts 15 and 1520, except with the written permission of the Administrator of the Transportation Security Administration or the Secretary of Transportation. Unauthorized release may result in civil penalty or other action. For U.S. government agencies, public disclosure is governed by 5 U.S.C. 552 and 49 CFR parts 15 and 1520.

SIGN USE / FUNCTION	MESSAGE PRIORITY		
	PRIMARY	SECONDARY	TERTIARY
Directional Overhead	Dallas-Forth Worth International Airport Terminals XXXXX (X = A, B, C, D, E) Terminal X (X = A, B, C, D, E) X Parking (X = A, B, C, D, E) Rental Cars North Exit; South Exit Return to Terminal Major surrounding access road names	Departures (don't use "Ticketing" on roads) Arrivals (don't use "Bag Claim" on roads) Express North Parking Express South Parking Remote North Parking Remote South Parking 1 Hour Parking	Airline names Curbside Bag Check
Directional Roadside	Rental Car Return; Rental Car Pick-Up Express North Parking Express South Parking Remote North Parking Remote South Parking North Exit; South Exit	Airline names Oversize Vehicles Rental Car Center Rental agency names	DFW Business Center
Identification	Dallas-Forth Worth International Airport Terminal X (X = A, B, C, D, E) Parking X (X = A, B, C, D, E) Airline names	Departures (don't use "Ticketing" on roads) Arrivals (don't use "Bag Claim" on roads) Express North Parking Express South Parking Remote North Parking Remote South Parking Rental Car Center	Curbside Bag Check Restricted areas Reserved Parking On-airport hotel names (Hyatt Regency; Grand Hyatt)
Information	Dynamic airport information		Safety related information Hazards/warnings
Regulatory/Safety	No Parking Fire Lane Caution: Pedestrians Crossing Authorized Personnel Only	Tow Away Zone Do Not Enter All FAA, TSA notices All Airport notices	

ROADWAYS

SIGN USE / FUNCTION	MESSAGE PRIORITY		
	PRIMARY	SECONDARY	TERTIARY
Directional	Vehicular: - X Parking (X = A, B, C, D, E) - Gates X#-X# (X=A, B, C, D, E) - EXIT - Level X (X = 1, 2, 3, 4, 5, etc.) - DOWN to Level X (X = 1, 2, 3, 4, 5, etc.) - UP to Level X (X = 1, 2, 3, 4, 5, etc.) Pedestrian: - Terminal X (X = A, B, C, D, E) - Sections X-X (X = A, B, C, D, E, etc)	Vehicular: - Valet - Valet / 1 Hour - 1 Hour - 2 Hour - Additional - High Vehicles Pedestrian: - DFW Valet	Pedestrian: - Elevators - Stairs
Identification	X Parking; X Parking North, Central, South - (X = A, B, C, D, E) EXIT Level X (X = 1, 2, 3, 4, 5, etc.) Section X# (X = A, B, C, D, E) Express North Parking Express South Parking Remote North Parking Remote South Parking	Valet 1 Hour 2 Hour	Elevators Stairs
Information	Parking rate information Parking spaces open/occupied counters Parking Directory	Handicap / Accessible Parking	Restricted areas Reserved Parking
Regulatory/Safety	No Parking No Parking Tow-Away Zone No Parking Fire Lane	DO NOT ENTER CLEARANCE: X'-X"	

GARAGES/PARKING

NOTE: Wording does not represent actual signage

SIGN USE / FUNCTION	MESSAGE PRIORITY		
	PRIMARY	SECONDARY	TERTIARY
Directional	Terminal X (X = A, B, C, D, E) Ticketing/Check-In All Gates Security Checkpoint Bag Claim Bag Claim X#-X# (X = A, B, C, D, E) Ground Transportation International Arrivals	Gates X#-X# (X = A, B, C, D, E) Airline names Passenger Pick-Up Individual ground transportation names: - Terminal Link, Taxi, Pre-Arranged Limo, Shared Ride, Rental Cars, Public Transit, Express/Remote (for parking shuttles), Courtesy Vans, DART Bus/Rail, Texrail, TNC (Transportation Network Companies such as Uber, Lyft, etc), Charter Bus, etc X Parking (X = A, B, C, D, E) Hourly/Daily Parking; Economy Parking Toilets	Pet Relief Area Tenant/concession/amenity names Telephones Lockers First Aid AED Police
Identification	Terminal X (X = A, B, C, D, E) Ticketing/Check-In Bag claim carousel no.'s (alpha-numeric) Ground Transportation	Airline names Individual ground transportation names: - Terminal Link; Taxi; Pre-Arranged Limo; Shared Ride; Rental Cars; Public Transit; Express/Remote (for parking shuttles); Courtesy Vans; DART Bus/Rail Elevator (or Elevator to:) Escalator (or Escalator to:) Toilets Men; Women; Family Baggage Information Baggage Services	Entry numbers (aka "Door" numbers) Pet Relief Area Telephones First Aid ATM; Currency Exchange Room numbers; room names Employee information Non-public spaces Advertising All tenant/concession/amenity names (i.e. ACO, USO, Traveler's Aid, Credit Union, Chapel, Vending, etc)
Information	All directories (static and dynamic) FIDS / BIDS / GIDS	Visual paging systems	Safety related information Hazards/warnings
Regulatory/Safety	Exit / Emergency Exit Only No Smoking / Smoking Area	All FAA, TSA notices Authorized Personnel Only	AED Fire Extinguisher Yield to Pedestrians No Stopping, Standing, Parking

TERMINALS - LANDSIDE (Ticketing/Bag Claim/Curbside Areas)

SIGN USE / FUNCTION	MESSAGE PRIORITY		
	PRIMARY	SECONDARY	TERTIARY
Directional	Gates X#-X# (X = A, B, C, D, E) Bag Claim (do not include carousel alpha-numeric ranges on airside signs) Bag Claim/Exit Skylink to: XXXX (X = A, B, C, D, E)	Toilets Men; Women; Family Airline club names Elevator (or "Elevator to:") Escalator (or "Escalator to:")	Amenities (USO, etc) Grand Hyatt Hyatt Regency
Identification	Gate numbers (number only, don't use the word "Gate" on IDs) Skylink	Elevator Toilets Information Flight Information Connecting Information	Room numbers; room names Employee information Non-public spaces Advertising All tenant/concession/amenity names (i.e. ACO, USO, Traveler's Aid, Credit Union, Chapel, Vending, etc)
Information	Airport directories (static and dynamic) FIDS / CGIDS	Visual paging systems	All required TSA/CBP notices Safety related Hazards/warnings
Regulatory/Safety	Exit / Emergency Exit Only No Smoking	All FAA, TSA notices Authorized Personnel Only Do Not Enter	AED Fire Extinguisher

TERMINALS - AIRSIDE (Concourses/Holdrooms/Gate Areas)

Figure 2.1.1

DFW Wayfinding Message Hierarchy Lists

2.1.4 MESSAGE APPLICATION

Wayfinding messages at DFW Airport will always be applied in a holistic and consistent manner. This includes the order of how wayfinding messages are listed, as well as the allowable number/quantity of wayfinding messages that are allowed on DFW wayfinding signage.

Listing Order

The majority of the international population read and decipher information in a prioritized “top-to-bottom” organizational format (see Figure 2.1.2). As a result, wayfinding destinations are typically prioritized/listed as:

- The most important destinations or closest in proximity are listed first.
 - i.e. the highest priority and/or closest proximity at the top
- Subsequent messages are listed in descending order downward.
 - i.e. the next most important and/or next in order of closest proximity

Number/Quantity of Messages

Directional messaging, for both pedestrian and vehicular traffic, tends to be overwhelming when more than three messages are used for a single direction on directional signage. Limiting the number/quantity of messages in a single direction is important for rapid deciphering of messaging while maintaining smooth wayfinding circulation flows.

Note that directional messaging should typically be limited to two messages for a single direction whenever possible, and a maximum of no more than three messages for a single direction. Four messages, although sometimes necessary and will depend on unique wayfinding circumstances, is not preferred and should be limited whenever possible. If four messages are deemed necessary, they should typically be limited to secondary or tertiary messaging/sign types (see Figure 2.1.2).

2.1.5 MESSAGE FUNCTION AND HIERARCHY RELATIONSHIPS

Along with prioritizing wayfinding messages, a hierarchy format (i.e. Primary vs. Secondary vs. Tertiary messages) will also typically have functional properties associated with them (i.e. general vs. specific). This will typically determine the categorization of sign type priority (i.e. Primary, Secondary and Tertiary sign types).

Message Priority Categorization and Function

It is important to understand that the same message may fall under a different priority category depending on its use and location within the overall wayfinding system. For example, traffic on a roadway approaching a terminal may find the term “Parking” as a primary message. However, the same term found in the terminal may be considered secondary when compared to other destinations in the terminal facility.

A message’s function will also typically change from the more general (i.e. “Terminal” or “Ground Transportation”) to the more specific (i.e. “Terminal A” or “Taxi, Shuttles, etc.”) as wayfinding traffic moves through an area/facility and approaches their destinations. Consistently maintaining this same functional use for messages throughout the entire wayfinding system is essential to smooth wayfinding traffic flow, and establishes solid visual continuity among messages/information and the sign system itself.

Message Priority and Sign Type Priority

The relationship between message function and message hierarchy also creates a basic foundation for the classification and determination of sign types. Message hierarchy (i.e. Primary, Secondary and Tertiary messaging) is used to group messages for their general use on directional, identification and informational sign types, each with their own specific application and usage priorities (i.e. Primary, Secondary and Tertiary sign type classifications).

Message Grouping by Priority

Emphasis should be placed on the reduction of signs and the amount of messaging wherever possible. However, it is typically a given that airport wayfinding sign systems are complicated with large quantities of varying sign types and associated messaging. As such, grouping messages by priority is necessary, and will result in fewer unique sign and message types.

For example, primary messages should typically be grouped with other primary messages whenever possible. If there is need for secondary messaging on the same sign, its importance will always be secondary to all primary messages. Ultimately, secondary messages may be better used on secondary sign types (if deemed appropriate for a given circumstance/condition or environment).

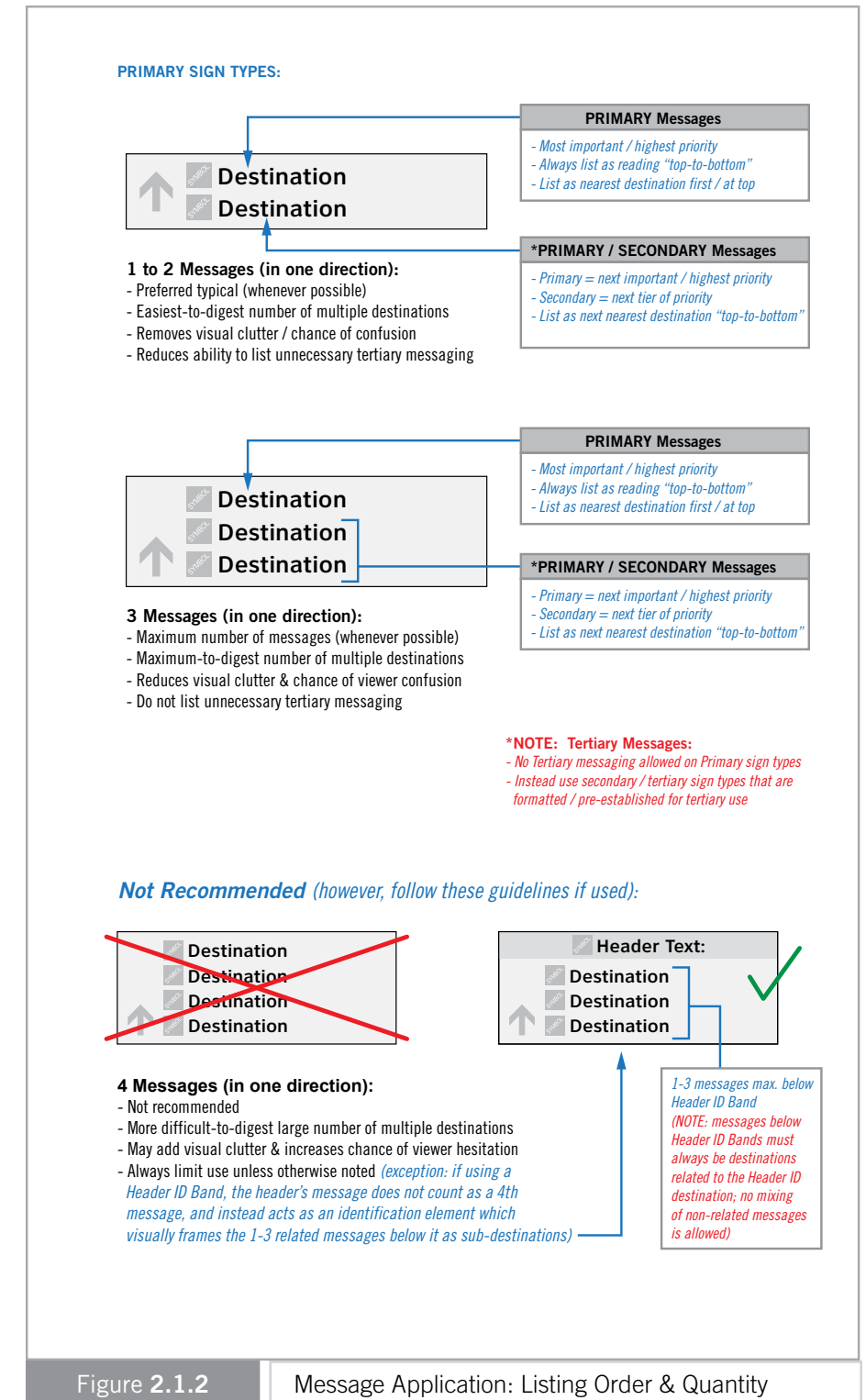

2.2 TYPOGRAPHY

2.2.1 OVERVIEW

Acceptable Type Styles

ClearviewText Medium, ClearviewText Bold (Pedestrian signage) and Clearview Highway (Roadway signage) typeface shall be the only typefaces used for all wayfinding signs at DFW (except for TXDOT, general DOT and regulatory signs). All sign text shall be set in approved Clearview family typefaces, unless otherwise specified and approved by the DFW Planning Department.

Other weights and styles of the Clearview typeface family may be appropriate in unusual circumstances. Recommendations to use alternate type weights must be submitted for approval by the DFW Planning Department. Justification of such proposals shall demonstrate the advantage offered by the non-standard type to the other signage in the area of the proposed use.

Pedestrian Typeface (see Figure 2.2.1a):

- ClearviewText font family will be the standard font used for all pedestrian/interior and garage signs
- ClearviewText Medium is the basic letter proportion used for directional and wayfinding signs (i.e. overhead, wall-mounted, etc)
- ClearviewText Medium will be used for wall-mounted room ID signs.
- ClearviewText Medium will be used for regulatory signs, with ClearviewText Bold used where emphasis is required
- ClearviewText Bold may be used on informational signs (i.e. information boards, guidelines, etc)
- ClearviewText Bold will be used for gate identification signs

Roadway Typeface (see Figure 2.2.1b):

Guide signing for DFW Airport roadways shall incorporate the Clearview Highway font series according to the following classification and usage guidelines:

- Clearview Highway 5-W (white on dark background) and 5-B (black on light background) shall typically be used for all guide signing with primary and secondary destinations and messages
- Clearview Hwy 5-W font is the replacement for FHWA Standard Highway Gothic font series E-modified, and may be used for letter heights down to and including 6 inches
- Clearview Highway 4-W is the replacement for FHWA Series E and shall be used for all action messages such as EXIT, STOP AHEAD or KEEP RIGHT typically found in footer panels
- Clearview Hwy 4-W is used for cardinal directions when used to indicate route direction, and numerals used in footer panels indicating distances
- Clearview Highway 3-W may be used on arterial, collector and local roads for replacement of FHWA Series D and used where panel sizes are limited
- Clearview Highway 3-W is used for letters in the Terminal Identifier Symbols
- Clearview Highway 2-W will be used for on street name signs or signing in low speed areas when Clearview Highway 5-W, or 4-W or 3-W cannot be applied

ClearviewText Medium:

ABCDEFGHIJKLMNOPQRSTUVWXYZ
abcdefghijklmnopqrstuvwxyz
1234567890 !@#\$%^&*()-+=*/:

ClearviewText Bold:

ABCDEFGHIJKLMNOPQRSTUVWXYZ
abcdefghijklmnopqrstuvwxyz
1234567890 !@#\$%^&*()-+=*/:

Figure 2.2.1a

Type Style: Pedestrian Wayfinding Text Example (Typical)

Clearview Highway 5-W (“W” = white text on dark background):

ABCDEFGHIJKLMNOPQRSTUVWXYZ
abcdefghijklmnopqrstuvwxyz
1234567890 !@#\$%^&*()-+=*/:

Clearview Highway 5-B (“B” = black text on light background):

ABCDEFGHIJKLMNOPQRSTUVWXYZ
abcdefghijklmnopqrstuvwxyz
1234567890 !@#\$%^&*()-+=*/:

Figure 2.2.1b

Type Style: Roadway Wayfinding Text (Typical)

Capitalization

Aside from special decorative uses where all-caps is desirable and/or used on specific regulatory related messaging, all word messages shall be in “Title Case.” Title Case is defined as the initial “alpha” letter shown in upper case followed by lower case letters for each individual word in a given message. Examples of exceptions include (but are not limited to):

- EXIT; EXIT ONLY
- DO NOT ENTER
- ATM
- KEEP LEFT; KEEP RIGHT
- NEXT LEFT; NEXT RIGHT

Other notables regarding message capitalization:

- As required by the Americans with Disabilities Act, all tactile messages shall be in all upper case
- All vehicular wayfinding signage must meet all requirements as established within MUTCD and TXDOT signage design standards
- Upper case letters shall have an upper case “X” height as determined by using a capital letter “I” when determining a layout’s text height dimension
- Lower case letters should have a lower case “x” height that is approximately two-thirds the height of the upper case letters
- Each word in a message shall be capitalized, with the exception of articles, prepositions and conjunctions (i.e. to, from, via, etc.)
- A consistent capital letter height shall always be maintained when wayfinding signs are used in sequence unless otherwise noted

Typographic Restrictions

Typefaces or weights not described here shall not be used at DFW, unless otherwise noted and approved by DFW. The following additional typographic restrictions shall always apply and be strictly adhered to when designing or specifying signage for DFW:

- Use only the type styles as specified for a specific traffic type as shown in this document (i.e. Pedestrian vs. Vehicular):
 - Use only Pedestrian type styles on Pedestrian wayfinding signage
 - Use only Vehicular type styles on Vehicular wayfinding signage
- Modification of letter shapes is prohibited unless otherwise specified and approved by DFW
- Condensed, extended, skewed, stretched, outlined or otherwise distorted type shall not be used

Language to this effect will always be included in the specifications for all related DFW wayfinding projects, and variances must be reviewed/approved by DFW.

Type styles specialized for a particular sign face or graphic layout shall be used exactly as specified in wayfinding signage design documents. Deviations from the sign type’s application provided in layouts are strictly prohibited. Refer to individual sign types for exact specifications and text sizing/layout details.

WARNING:

This record contains Sensitive Security Information that is controlled under 49 CFR parts 15 and 1520. No part of this record may be disclosed to persons with a “need to know,” as defined in 49 CFR parts 15 and 1520, except with the written permission of the Administrator of the Transportation Security Administration or the Secretary of Transportation. Unauthorized release may result in civil penalty or other action. For U.S. government agencies, public disclosure is governed by 5 U.S.C. 552 and 49 CFR parts 15 and 1520.

2.2.2 TYPE SPACING

Letter Spacing (Kerning and Tracking)

Kerning is typically defined as the process of adjusting the spacing between characters in a proportional font, usually to achieve a visually pleasing result within a set of readable text. Also note that while kerning adjusts the individual spacing between individual letter forms, tracking instead adjusts the spacing uniformly over an overall set/range of characters in a word or set of words. Tracking adjustments are not usually as ideal for readability on wayfinding signage as they tend to make individual words and groups of words more difficult to read, whereas kerning helps to maintain the visual harmony of words.

Unless otherwise indicated, all sign messages shall use the Clearview font family's default letter spacing with regards to kerning and tracking. Messages set according to the typeface maker's letter spacing standards will not normally require adjustment (see Figures 2.2.2a and 2.2.2b). In some circumstances, modification of the spacing between individual letters or letter-sets may improve the appearance and legibility of a sign message. Examples of typical needs for kerning adjustments include (but may not be limited to) improved visibility at increased viewing distances, as well as the elimination of unacceptable levels of "halation" (aka visual blurring together of letter strokes/graphic elements) due to internal or external illumination of the sign face.

Designers are required to review sample messages for all sign projects, and shall recommend spacing modifications where they can be shown to be advantageous or necessary. In these instances, hand-kerning will be required to adjust spacing and shall be noted as such within the sign's specific layout using a +/- pica unit of measurement as used within professional graphic design software. Other letter spacing restrictions include: reducing normal letter or word spacing (i.e. to fit a lengthy message within a restrictive size layout area) is not acceptable and shall always be avoided; punctuation marks, which relate to two letters, should be spaced equally from both letters.

Word Spacing

Unless otherwise indicated, spacing between words in a message is typically $\frac{3}{4}$ (.75) times the capital letter height (adjust by appropriate percentage if hand-kerning). For example, a message using 4" cap letters will have approximately 3" between words (see Figures 2.2.2a and 2.2.2b).

Line Spacing (Leading)

Leading is typically defined as the distance between the baselines of successive lines of type. Typically the *spacing between *related* lines of message text (i.e. a message in a layout that must continue to the next line down due to not enough available width on the first line) will typically be approximately $\frac{1}{2}$ (.50) times the capital letter height (unless otherwise noted). And typically the *spacing between *unrelated* message text lines (i.e. two completely separate ideas/destinations/messages) will typically be approximately 1 times the capital letter height (unless otherwise noted).

**NOTE: Always refer to actual DFW wayfinding signage face layouts for all final definitive line spacing requirements per each individual sign type as shown in current DFW wayfinding signage design intent/construction documents.*

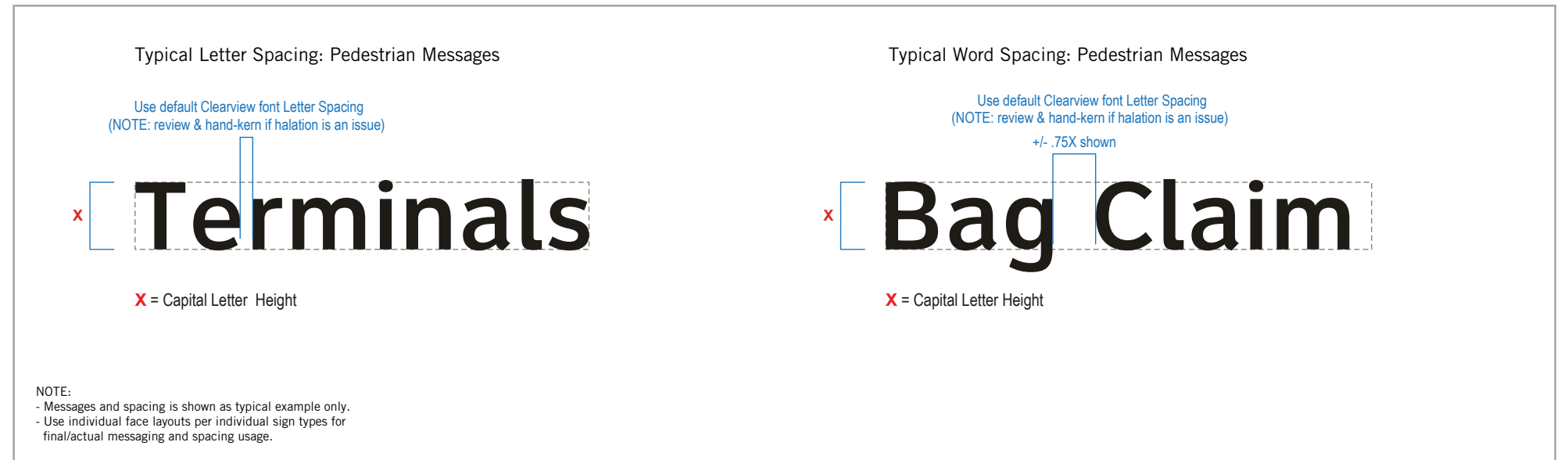

Figure 2.2.2a

Pedestrian Messages: Typical Type Spacing

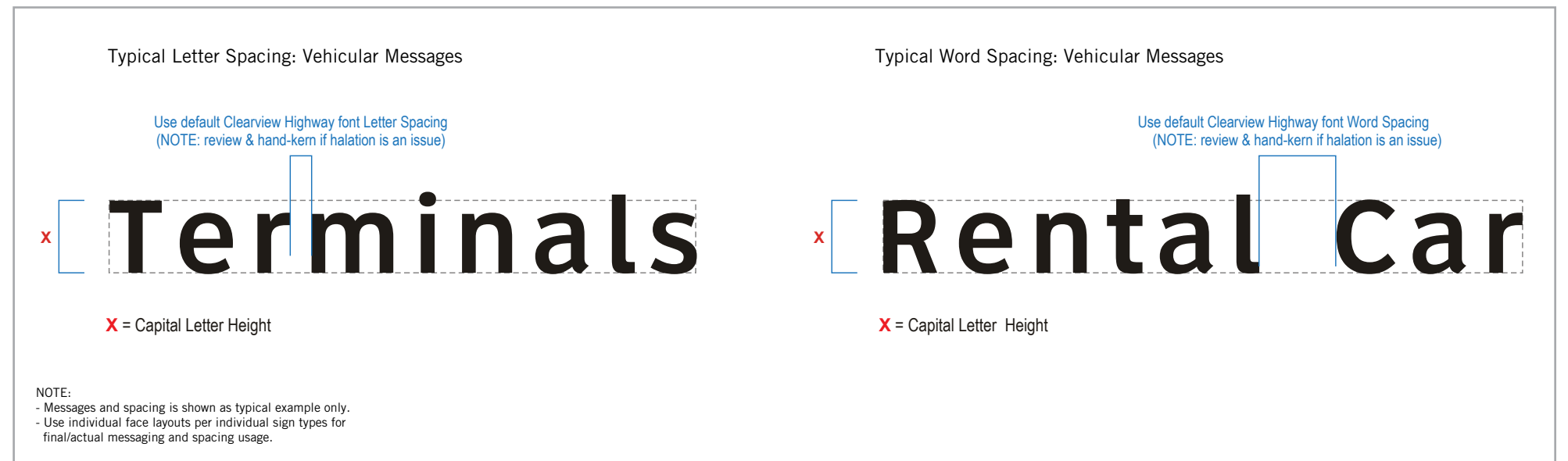

Figure 2.2.2b

Roadway Messages: Typical Type Spacing

WARNING:

This record contains Sensitive Security Information that is controlled under 49 CFR parts 15 and 1520. No part of this record may be disclosed to persons with a "need to know," as defined in 49 CFR parts 15 and 1520, except with the written permission of the Administrator of the Transportation Security Administration or the Secretary of Transportation. Unauthorized release may result in civil penalty or other action. For U.S. government agencies, public disclosure is governed by 5 U.S.C. 552 and 49 CFR parts 15 and 1520.

2.2.3 LEGIBILITY

Legibility is typically defined as the recognition of various elements that make a message or symbol understandable without the aid of additional wording or pre-conditioning. Additional factors may effect legibility including:

- Placement
- Lighting
- Contrast
- Viewing angles and distances

These factors must always be taken into account by designers when developing new or updated wayfinding signage to be implemented at DFW.

Pedestrian Legibility

It is necessary to have consistent placement and presentation of messaging on all wayfinding signage that are viewable to pedestrian traffic. This includes the sign's height above finished floor, and the overall size of the sign (including it's support structure). This will minimize unintentional misinterpretation of the pathways and uses of the facility when viewing the nearby wayfinding signage.

A pedestrian sign's location will often dictate the range of acceptable visibility to the viewer in order for them to quickly and effectively interpret the information. If the viewer is given an appropriate distance to comprehend the messaging, hesitation will be reduced and informed decisions will be made regarding changing direction or continuing on the same pathway. In a fast paced (often congested) environment such as an airport, a conservative pedestrian viewing distance of approximately 25 feet to each inch of capital letter height should be used when specifying wayfinding signage (see Figure 2.2.3). However, all text on pedestrian wayfinding signage must always follow all sizing and legibility requirements as established by the latest editions of the ADA and Federal, State and Local Accessibility and Code Standards.

Vehicular Legibility

Similar to pedestrian traffic, it is also imperative to maintain consistent placement and presentation of wayfinding messaging on all signs that are intended to be viewed and used by vehicular traffic. Again, this will minimize unintentional misinterpretation of the pathways and uses of the Airport's roadways, as well as allow drivers ample time to make safe and informed decisions.

There are several factors that affect the legibility of vehicular messages, including (but not limited to) the sign's height above finished grade, lateral spacing from the roadway, number of messages, overall size of the sign (including support structure) and the speed at which a vehicle is traveling. As a result, when designing new or updated vehicular wayfinding signage, *a set of general design guidelines should be used when determining a conceptual reference point for adequate message size (see Figure 2.2.3).

**NOTE: The information shown in Figure 2.2.3 is based on typical and generally accepted wayfinding industry standard practices (equations & table provided by the United States Sign Council, USSC), and is only a basic conceptual design reference. These are general "rule-of-thumb" guidelines and should only be used as an initial starting point when determining vehicular wayfinding signage legibility. This information should not be construed as absolute or final. All vehicular wayfinding signage legibility must meet all requirements as established within MUTCD and TXDOT signage design standards.*

Typical Pedestrian View Distances and Legibility Considerations:

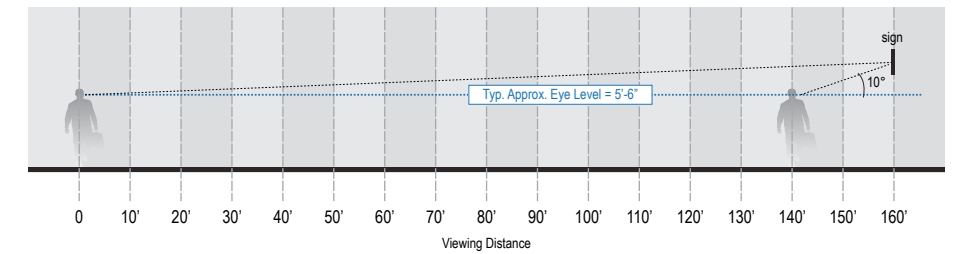
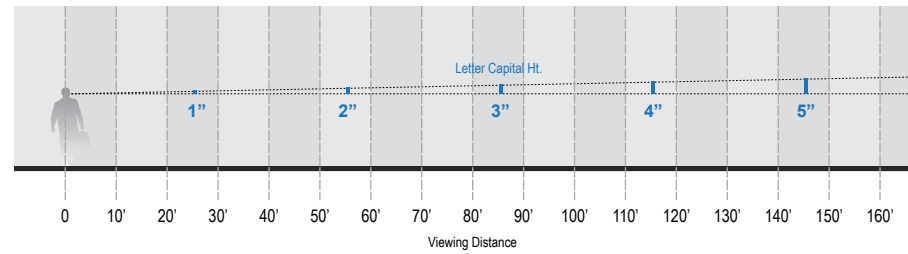

Typical Vehicular View Distances and Legibility Design Guidelines:

Typical Vehicular Sign Legibility Design Formulas:

Source:
USSC Sign Legibility Rules of Thumb, United States Sign Council (latest ed.: 2006 shown)

Example Equations

Notes:
LH = Letter Height (upper case letters in inches)
LN = No. of Lanes of Traffic
LO = Lateral Offset (from curb in feet)
LI = USSC Legibility Index (from Table 1)

Example Equation 1:
 $LH = (LN \times 10 + LO) / 5$

Equation 1 Example Solution:
Conditions:
- 2-Lane Roadway
- Lateral Offset = 37 feet from curb
- Letter Style = unknown

$LH = (2 \times 10 + 37) / 5$
 $LH = 57 / 5$
 $LH = 11.4 \text{ inches (upper case letters)}$

Example Equation 2:
 $LH = (LN \times 10 + LO) / (LI / 6)$

Equation 2 Example Solution:
Conditions:
- 2-Lane Roadway
- Lateral Offset = 37 feet from curb
- Letter Style = Helvetica, all caps
- Light Letters on Dark Background
- USSC Legibility Index = 22 ft / in (from Table 1)

$LH = (2 \times 10 + 37) / (22 / 6)$
 $LH = 57 / 3.67$
 $LH = 15.5 \text{ inches (upper case letters)}$

Table 1: USSC Standard Legibility Index (from source page 5)

*Illumination	**Letter Style	Letter Color	Background Color	Legibility Index (LI)	
				Title Case	All Caps
External	Helvetica	Black	White	29	25
External	Helvetica	Yellow	Green	26	22
External	Helvetica	White	Black	26	22
External	Clarendon	Black	White	28	24
External	Clarendon	Yellow	Green	31	26
External	Clarendon	White	Black	24	20
Internal Translucent	Helvetica	Black	White	29	25
Internal Translucent	Helvetica	Yellow	Green	37	31
Internal Translucent	Clarendon	Black	White	31	26
Internal Translucent	Clarendon	Yellow	Green	37	31
Internal Opaque	Helvetica	White	Black	34	29
Internal Opaque	Helvetica	Yellow	Green	37	31
Internal Opaque	Clarendon	White	Black	36	30
Internal Opaque	Clarendon	Yellow	Green	37	28
Neon	Helvetica	Red	Black	29	25
Neon	Helvetica	White	Black	38	32

*NOTE: Illumination Name Variations ("aka") may include:
- External: Internal with Full Translucent Background; Internal w/ Translucent Letters & Opaque background; Exposed Neon Tube

**NOTE: Letter Styles shown are typical examples only:
- Helvetica = a typical example of a sans serif version of a typeface
- Clarendon = a typical example of a serif version of a typeface
- Text height as prescribed by MUTCD

How to Use Table 1:

- Determine letter height for given viewing distance
- Select combination for: letter (font) style, illumination, letter color & background color most closely resembling table's listings
- Divide viewing distance (i.e. Veiver Reaction Distance "VRD" in feet) by applicable Legibility Index (aka "LI") value in Table 1
- Result = Capital Letter Height (in inches)

- Example:
VRD = 600 ft.
LI = 30
 $600' / 30 = 20'$
Capital Letter Ht. = 20 in.

Typical Driver Focusing Points at Various Speeds:

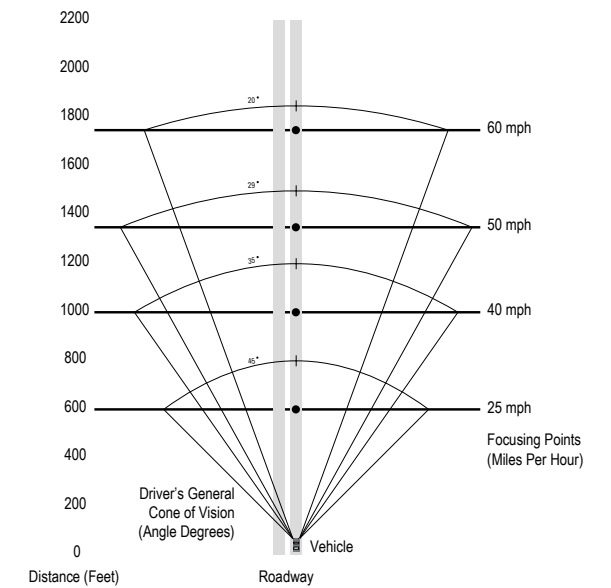

Figure 2.2.3

Typical Wayfinding Industry Accepted Legibility Design Guidelines

Testing Legibility

It is also highly recommended that field testing of 1:1 actual-size prototypes be utilized to determine the maximum effectiveness of a conceptual wayfinding sign's legibility per its individual location and line-of-sight conditions within a given area/project. All prototype development and field testing must be coordinated with and approved by DFW.

Consistency in Legibility

Consistent sizing of wayfinding message text and symbols from sign-to-sign throughout an airport also adds to the overall effectiveness of the wayfinding system. It establishes a consistent and professional looking display of information, which in turn will allow for much more rapid comprehension of the wayfinding information and general orientation with in an airport's varied and complex environments.

2.3 SYMBOLS

2.3.1 OVERVIEW

A cohesive and easily identifiable set of universal symbols is an absolutely critical part of a successful wayfinding system. To be most effective, these universal symbols must work in harmony with the wayfinding nomenclature/terminology, and must always be applied with consistency. Universal symbols should also always be used for reinforcement and visual confirmation of wayfinding message text, especially at the pedestrian level.

Note the following philosophies and guidelines that were used in the development the DFW wayfinding system's universal symbol set:

Symbols Supplementing Messaging

The use of universal symbols, in tandem with short verbal messages, is more effective than the use of symbols or messages by themselves. However, note that universal symbols should act as a *supplement* to the messaging, rather than serving as the primary graphic or messaging element.

International Traveler Consideration

Accommodating multiple languages on directional signage is costly, impractical and not recommended. Universal symbols can serve as an effective means of assisting international and non-English speaking travelers with locating airport destinations.

Limit Use to Priority Messaging

Mixing universal symbols (and their related message text) for relatively minor or tertiary airport functions/activities/tenants with essential public wayfinding information weakens the overall communication of the wayfinding system. By limiting their use to priority airport messaging and destinations, universal symbols help to supplement and graphically highlight the importance of the priority messaging.

Less is More

Too many universal symbols, messages or arrows at any one location can be counter-productive to the wayfinding information being provided. An over-abundance of symbol use and messaging in a given direction or at a decision point can result in information overload, which in turn will cause hesitation, confusion and general distrust of the wayfinding system.

Symbol Categorization

Universal symbols have been divided into specific categories based on their function as they are to be used within specific areas of DFW airport areas. These categories include:

- Pedestrian wayfinding signage:
 - Travel Symbols
 - Public Service Symbols
 - Concessions Symbols
 - Curbside/Ground Transportation Symbols
 - Terminals/Gates Symbols
 - Inter-Terminal Transit Symbols
 - Regulatory Symbols
- Vehicular wayfinding signage:
 - Only certain/select Travel Symbols (such as Parking)
 - Terminal ID Symbols
 - Highway ID Symbols

Regulatory Symbols

Symbol shape, placement and color on all regulatory signs shall conform to the latest editions of the ADA Standard for Accessible Design, local/national building codes, TXDOT Traffic Manual and the Federal Manual on Uniform Traffic Control Devices (MUTCD).

Change Procedures and Restrictions for Symbols

To be most effective, a symbol system must allow for the fluctuating nature of a modern and continually changing airport related terminology. Development of new universal symbol artwork is allowed when deemed necessary and appropriate for a given situation/condition; consistent use of DFW universal symbol artwork standards for established messaging is always required. All changes to existing and/or additions of new universal symbols shall require coordination, review and approval by DFW. Universal symbols not approved by DFW as described in this section and/or not illustrated in this document shall not be used.

DFW Logo Usage

Use of the DFW logo and/or literal/verbatim applications of the logo's elements within the wayfinding system is not allowed. When the DFW logo is applied in inconsistent, haphazard or inappropriate ways, it weakens the strength of the DFW brand itself, and may result in negative associations with the DFW brand, regardless of original intent. It should also be noted that using literal representations of the DFW logo for the purposes of decoration and/or graphic filler on wayfinding signage will create an additional layer of visual clutter that must also be digested within the process of deciphering of wayfinding messaging and information.

DFW Universal Symbols

An effective set of universal symbols will always supplement and enhance the messaging rather than graphically overpower it. Universal symbols usage within DFW shall always be applied consistently and holistically across the entire airport, and will always be applied with their associated messaging unless otherwise noted. Application of DFW universal symbols with no accompanying message text is not allowed unless otherwise noted.

Additionally, a basic graphic element description of DFW universal symbol artwork is provided in Figure 2.3.1. For a complete listing of DFW universal symbols and their associated messaging, see Figure 2.3.2.

Ground Transportation ID Symbols - Special Usage

Ground transportation symbols, when used for identification purposes, are the only exceptions to standard universal symbol color/graphic applications unless otherwise noted (see Figure 2.3.1). Also note that this special usage color should be reserved only for application on ground transportation identification signage, otherwise standard white/blue symbols is to be used on all other wayfinding signage. Application of DFW universal symbols with no accompanying message text is not allowed unless otherwise noted.

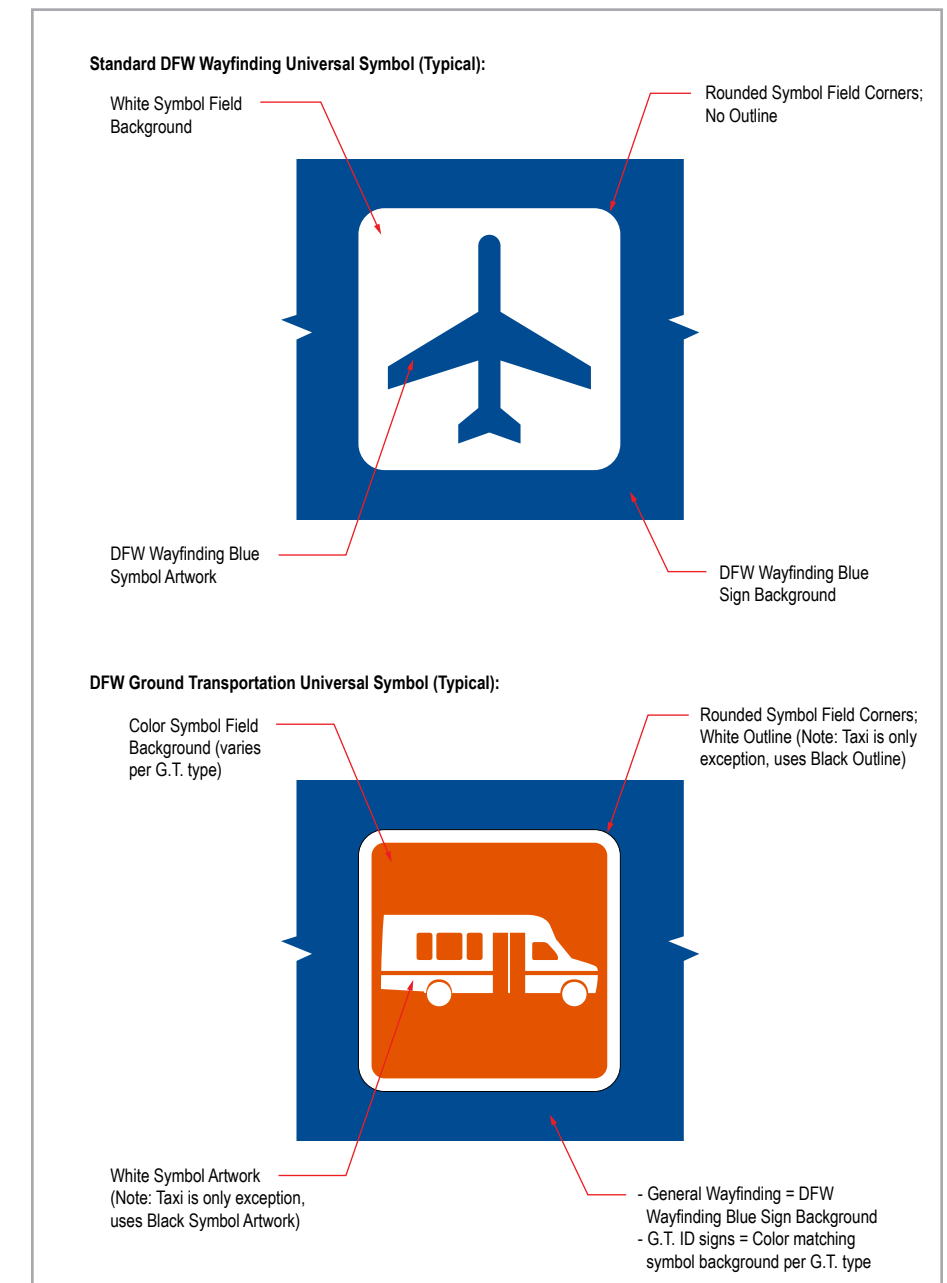

Figure 2.3.1

Universal Symbols: Graphic Element Description

TRAVEL SYMBOL - WAY FINDING (Blue background)



PUBLIC SERVICE SYMBOLS - WAY FINDING (Blue background)

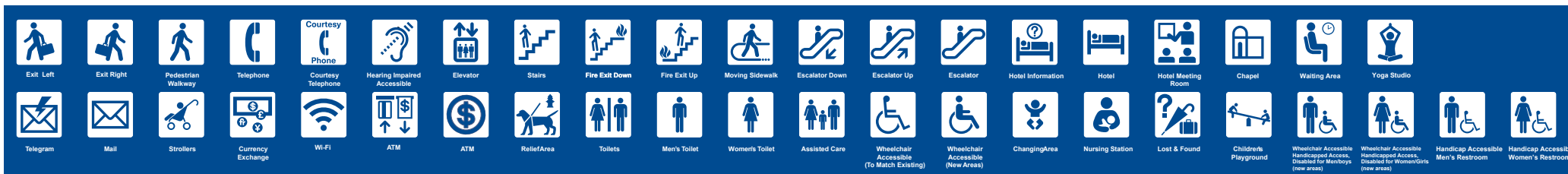

CONCESSIONS (Blue background)



GROUND TRANSPORTATION (Blue or other solid background)



TERMINALS (All solid backgrounds)



DFW BRAND LOGOS



REGULATORY (Blue or other solid background)



SWATCH COLORS



SECURITY CHECKPOINT GRAPHICS

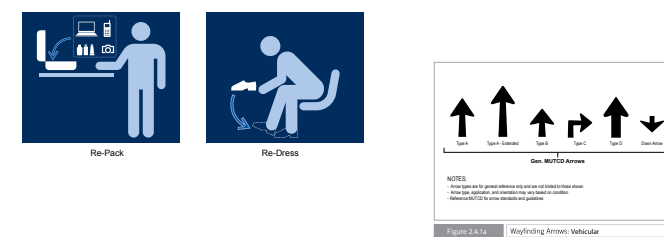

ARROWS



Note: See Wayfinding and Signage Observations and Recommendations for Iconography Study

Figure 2.3.2

DFW Wayfinding Universal Symbols Lists

WARNING:

This record contains Sensitive Security Information that is controlled under 49 CFR parts 15 and 1520. No part of this record may be disclosed to persons with a "need to know," as defined in 49 CFR parts 15 and 1520, except with the written permission of the Administrator of the Transportation Security Administration or the Secretary of Transportation. Unauthorized release may result in civil penalty or other action. For U.S. government agencies, public disclosure is governed by 5 U.S.C. 552 and 49 CFR parts 15 and 1520.

2.4 ARROWS

2.4.1 OVERVIEW

Arrows used as directional elements are more flexible and require less sign layout space than messages. Arrow graphic proportions and artwork should be standardized, and should always be applied in a consistent manner across the entire wayfinding signage system. Note that careful design and review of sign layouts must be done in order to produce proper proportioning between arrows, messages and symbols dimensions.

2.4.2 ARROW APPLICATION GUIDELINES

The angle of rotation and directional information that arrows convey is of equal importance to the consistent use of an arrow's graphic style. The arrow rotation which may be used to convey a message of "straight ahead" is of particular interest. Either "up arrow" or the "down arrow" can be used to convey the same message, but it's application and surrounding environmental context is what drives the differentiation. For example, an arrow pointing "down" near a downward stairway entrance will mean "straight ahead; down these stairs." However, an arrow pointing "down" over the entrance to a queuing lane will conversely mean "straight ahead; use this lane."

Note that once the general context of the directional message to be conveyed has been evaluated and selected, consistent application should always be continued throughout the entire signage system. The following are guidelines when using arrows within DFW's wayfinding system:

Arrow Sign Face Positioning/Sizing Relationship (see Figure 2.4.1a to 2.4.1c)

- The placement of arrows on sign faces should conform to the standards and guidelines provided. Arrows should not be positioned in any other location on the sign face. Arrows should not be stretched or re-proportioned outside of the standard locked-up wayfinding arrow artwork as shown (see Figure 2.4.1b). See the DFW Signage Standards and Guidelines for specific sign type arrow/graphic face layouts
- Arrows should not point into text:
 - Left-facing arrows should be located on the left side of signs (corresponding message text should be left justified)
 - Right-facing arrows should be located on the right side of signs (corresponding message text should be right justified)
 - Upward-facing arrows are normally located closest to the flow of traffic (corresponding message text should be justified based on arrow location on sign face).
- Roadway Overhead Signs:
 - Arrows should be held within a designated area along the lower edge of the message area. Arrows are normally positioned flush with the bottom edge of the designated arrow area. See the DFW Signage Standards and Guidelines for vehicular sign type arrow/graphic face layouts
- Roadway Roadside Signs:
 - Arrows should be held within a designated vertical column along the left or right side of the message area
 - Pedestrian Signs:

- Arrows should be held within a designated vertical column along the left or right side of the message area. See the DFW Signage Standards and Guidelines Manual for pedestrian sign type arrow/graphic face layouts.

Arrow Rotation Angles (see Figure 2.4.1f)

- When used for standardized wayfinding, the standard arrow can be rendered in eight (8) different standard rotation angles.
- No alternate angles are acceptable, unless approved by DFW.

Arrow Applications

- Pedestrian Signs (see Figure 2.4.2a):
 - Arrow rotation angles and applications for pedestrian specific traffic should follow the guidelines provided in this section (see Figure 3.2.7a).
 - Straight-ahead pedestrian movement should be indicated by upward-facing arrows, unless a downward-facing arrow can be shown to be clearly advantageous in a specific circumstance (i.e. queuing lane identification/purposing, etc)
 - Straight downward-facing arrows are normally reserved to indicate movement to a lower level for pedestrian traffic.
- Vehicular Signs (see Figure 2.4.2b):
 - Arrow rotation angles and applications for vehicular specific traffic should follow the guidelines provided in the TXDOT Traffic Manual and the Federal Manual of Uniform Traffic Control Devices (MUTCD). Arrow position on overhead signs shall relate to the traffic lanes and their designated traffic flow

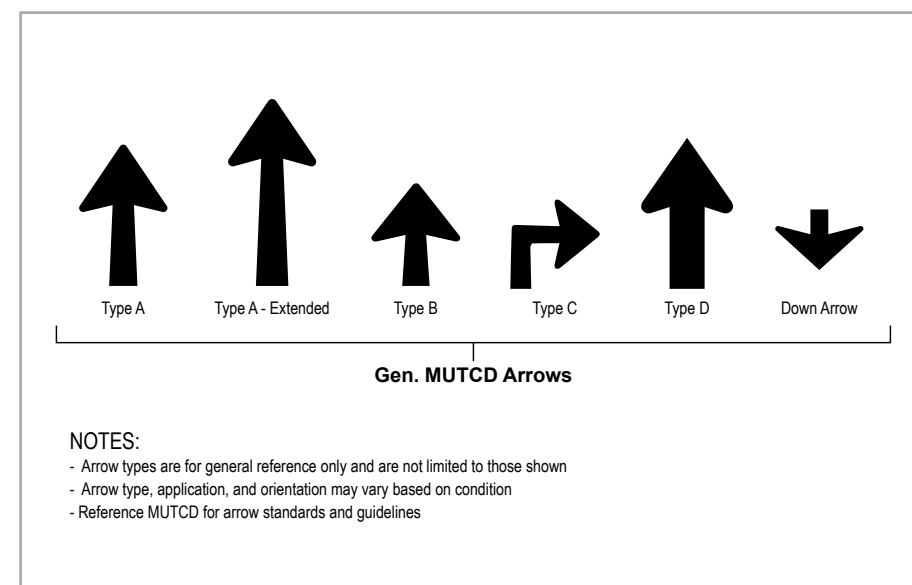

Figure 2.4.1a

Wayfinding Arrows: Vehicular

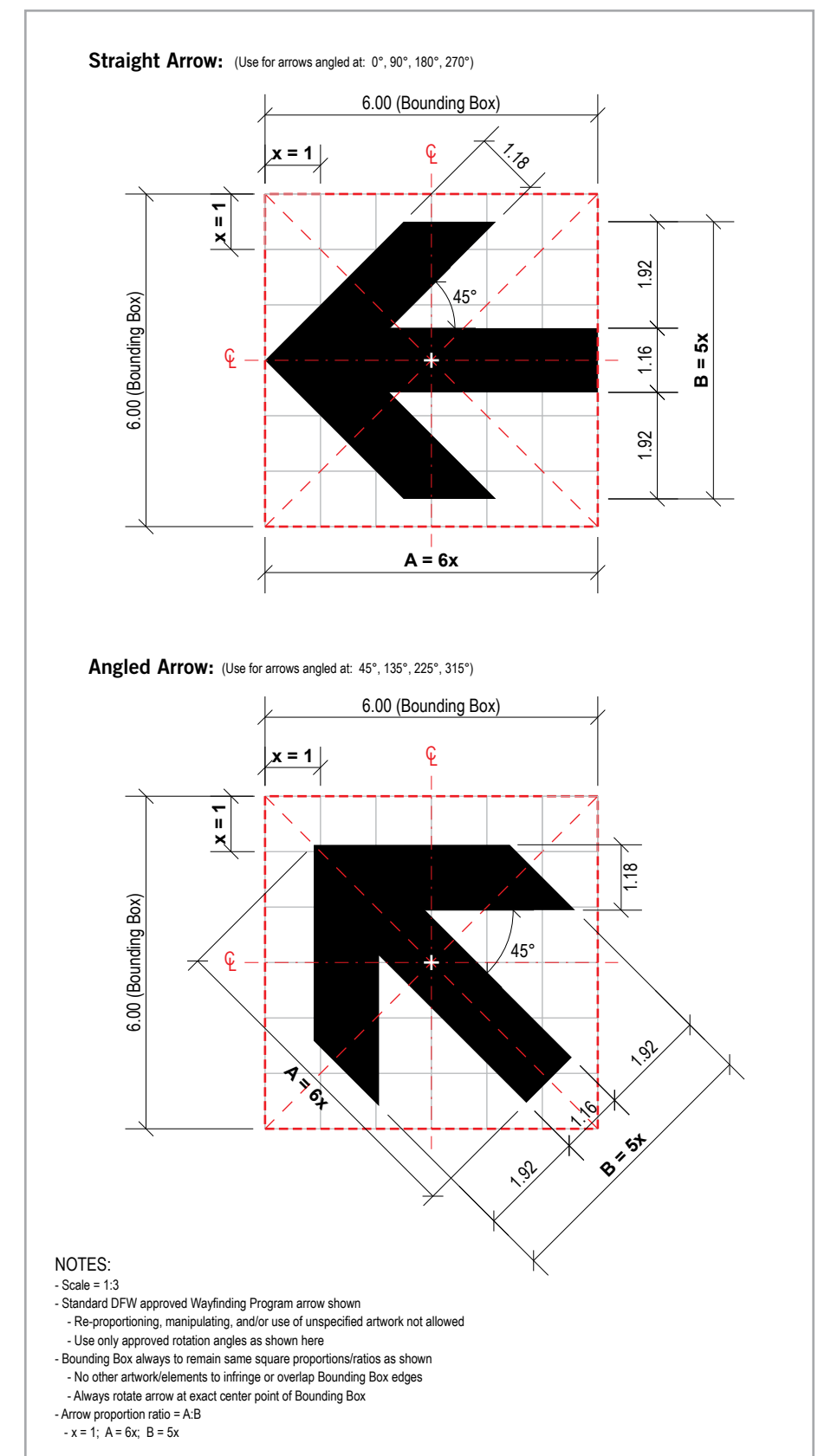

Figure 2.4.1b

Wayfinding Arrows: Pedestrian - Proportions

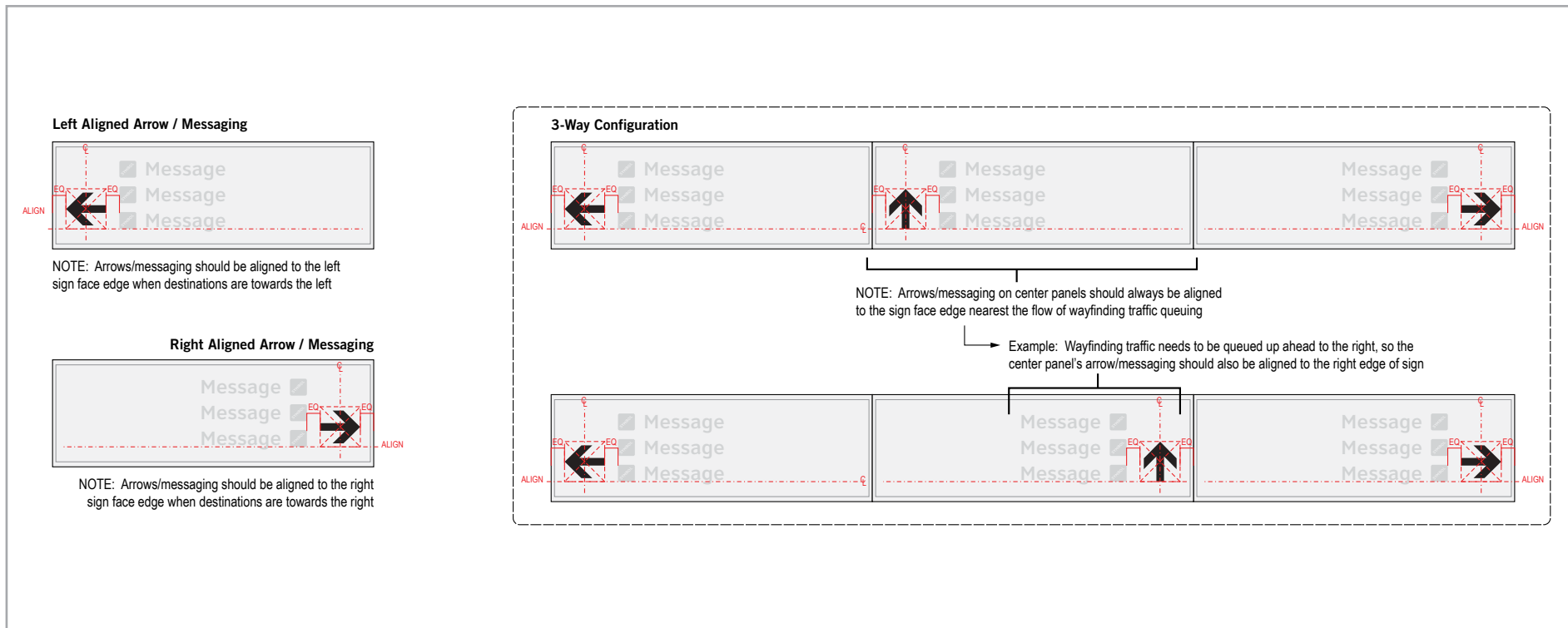

Figure 2.4.1c Wayfinding Arrows: **Typical Alignment - Pedestrian Terminal/Garage Areas**

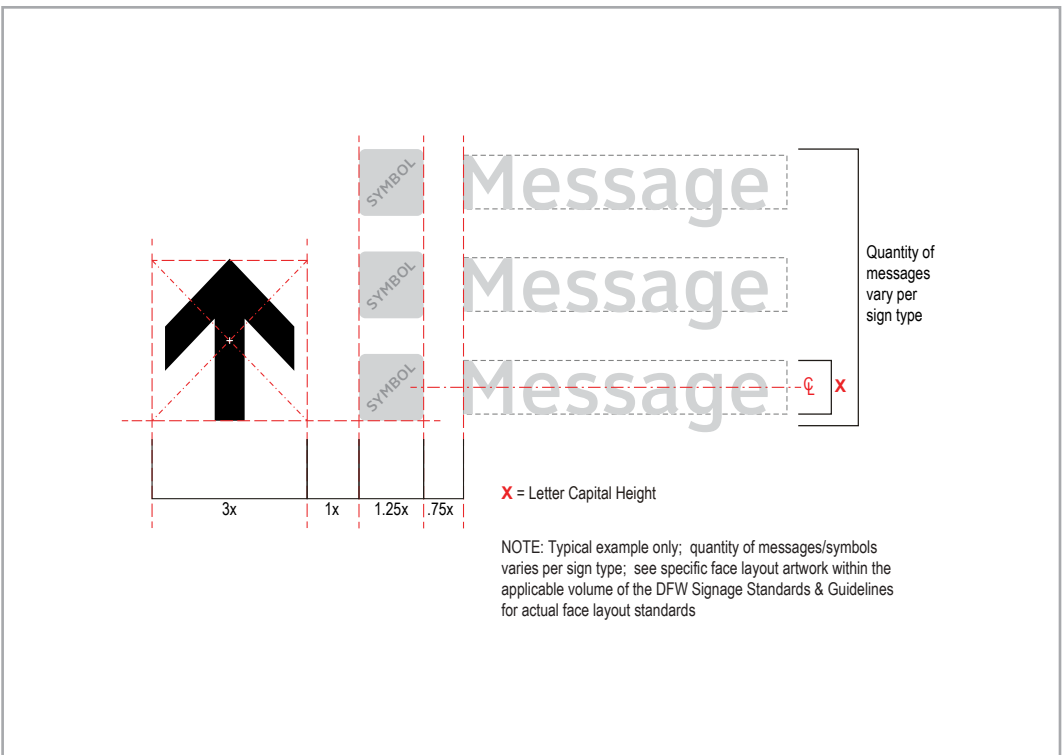

Figure 2.4.1d Wayfinding Arrows: **Size Relationships - Pedestrian**

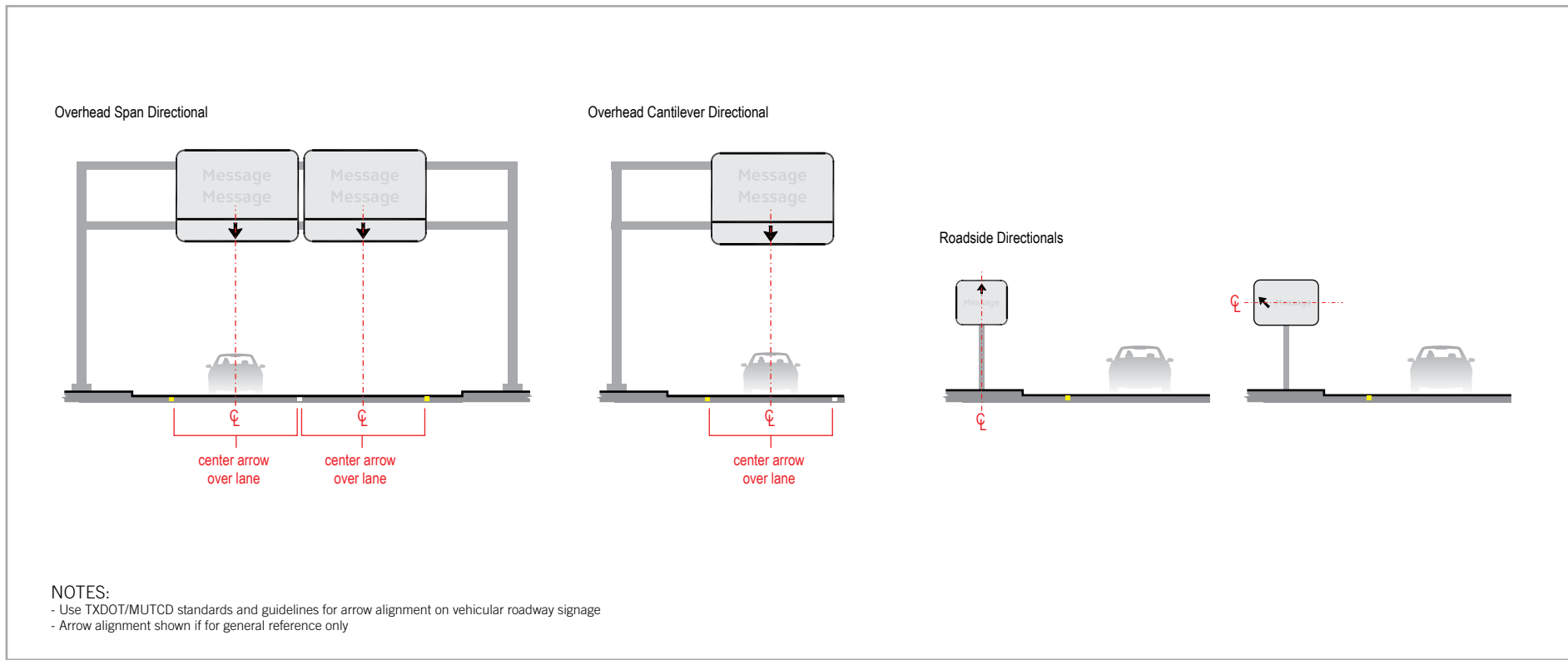

Figure 2.4.1e Wayfinding Arrows: **Typical Alignment - Vehicular Roadway Areas**

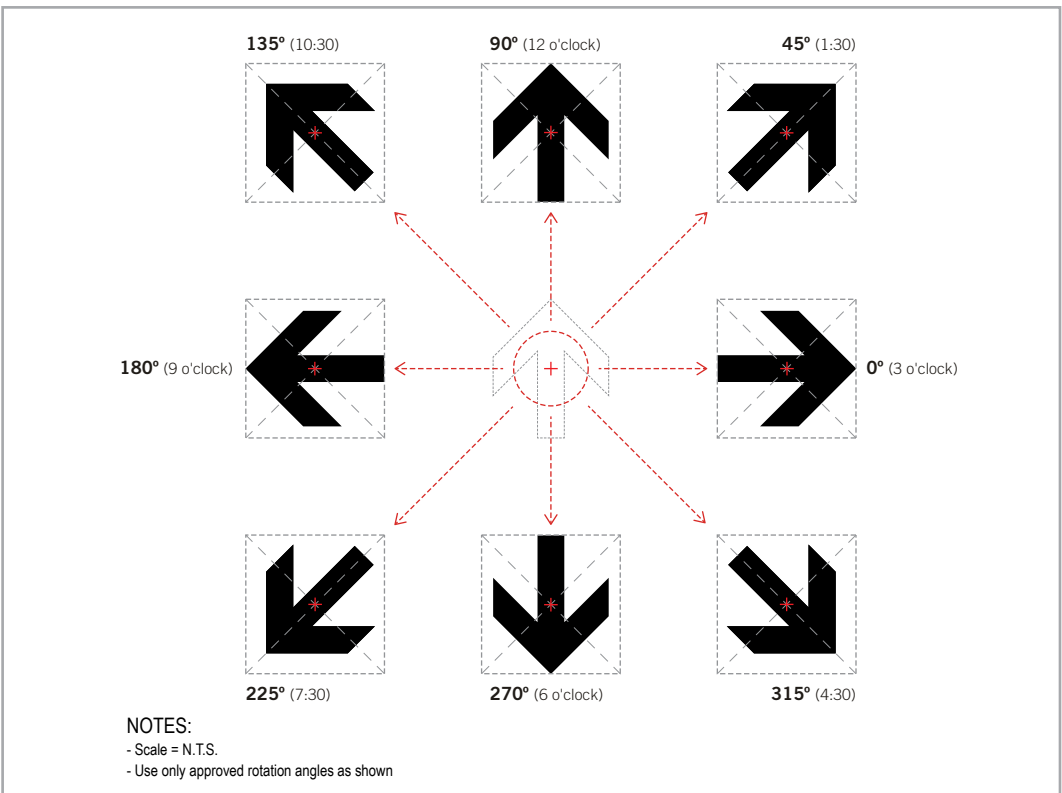

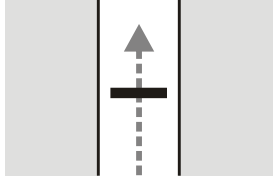

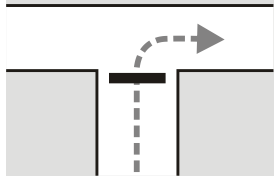

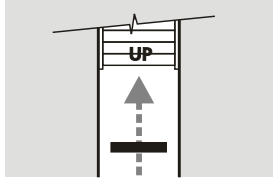

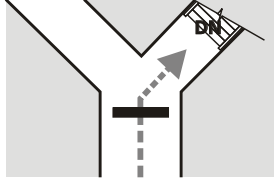

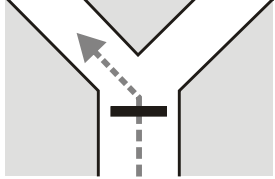

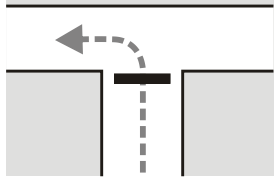

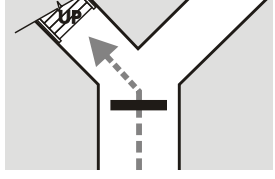

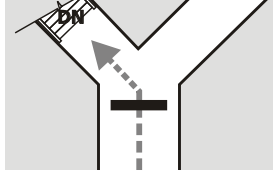

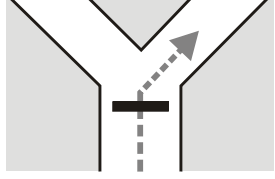

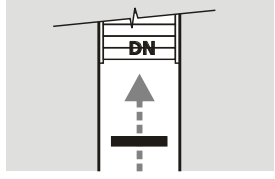

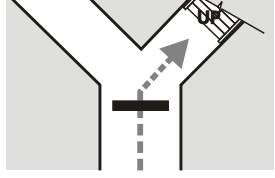

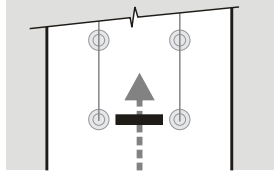

Figure 2.4.1f Wayfinding Arrows: **Rotation Angles**

ALL Directionals

ARROW ROTATION	LOCATION PLAN EXAMPLE	MESSAGE CONVEYED	ARROW ROTATION	LOCATION PLAN EXAMPLE	MESSAGE CONVEYED
 90° (12 o'clock)		Straight Ahead	 0° (3 o'clock)		Right
 90° (12 o'clock)		Up	 315° (4:30)		Down on the Right
 135° (10:30)		Ahead on the Left	 180° (9 o'clock)		Left
 135° (10:30)		Up on the Left	 225° (7:30)		Down on the Left
 45° (1:30)		Ahead on the Right	 270° (6 o'clock)		Down
 45° (1:30)		Up on the Right	 270° (6 o'clock)		Use this lane / row / aisle / line

NOTES:
 - Source: Guidelines for Airport Signage & Graphics - Latest Ed.
 - Schematic representations only; drawings not to scale

Figure 2.4.2a Wayfinding Arrows: Applications - Pedestrian Terminal/Garage Areas

OVERHEAD Directionals		
ARROW ROTATION	LOCATION PLAN EXAMPLE	MESSAGE CONVEYED
Existing: ↑ 90° (12 o'clock)		Straight Ahead (Arrow Justified Center)
Existing: ↓ 270° (6 o'clock)		Straight Ahead: Use This Lane (Arrow Justified Center)
Existing: ↘ 315° (4:30)		Down on the Right (Arrow Justified Center)
Existing: ↙ 225° (7:30)		Down on the Left (Arrow Justified Center)
Existing: ↗ 45° (1:30)		Exit/Ahead on the Right (Arrow Justified Center)
Existing: ↖ 135° (10:30)		Exit/Ahead on the Left (Arrow Justified Center)

CANTILEVER Directionals		
ARROW ROTATION	LOCATION PLAN EXAMPLE	MESSAGE CONVEYED
Existing: ↑ 90° (12 o'clock)		Straight Ahead (Arrow Justified Center)
Existing: ↑ 90° (12 o'clock)		Straight Ahead (Arrow Justified Center)
Existing: ↓ 270° (6 o'clock)		Straight Ahead: Use This Lane (Arrow Justified Center)
Existing: ↓ 270° (6 o'clock)		Straight Ahead: Use This Lane (Arrow Justified Center)
Existing: ↖ 135° (10:30)		Exit/Ahead on the Left (Arrow Justified Center)
Existing: ↗ 45° (1:30)		Exit/Up on the Right (Arrow Justified Center)

ROADSIDE Directionals		
ARROW ROTATION	LOCATION PLAN EXAMPLE	MESSAGE CONVEYED
Existing: ↑ 90° (12 o'clock)		Straight Ahead (Arrow Justified Left)
Existing: ↑ 90° (12 o'clock)		Straight Ahead (Arrow Justified Right)
Existing: ↗ 45° (1:30)		Exit/Ahead on the Right (Arrow Justified Right)
Existing: → 0° (3:00)		To the Right (Arrow Justified Right)
Existing: ↖ 135° (10:30)		Exit/Ahead on the Left (Arrow Justified Left)
Existing: ← 180° (9 o'clock)		To the Left (Arrow Justified Left)

NOTES:
 - Arrow applications shown are for general reference only
 - Arrow type and application may vary based on condition
 - Reference MUTCD for additional standards and guidelines

Figure 2.4.2b Wayfinding Arrows: Applications - Vehicular Roadway Areas

2.5 COLORS

2.5.1 OVERVIEW

In order to maintain a visually unified system of signs throughout all DFW facilities, the presentation of color must be consistent on all elements throughout the entirety of the wayfinding system. This section will provide an overview of the adopted color system as it should be used for all new and updated wayfinding signage at DFW.

2.5.2 COLOR DESIGN CONSIDERATIONS

The following general design considerations and guidelines should be utilized when specifying the DFW wayfinding color system:

Simple, Supplemental and Consistent:

- Colors, as they pertain to branding specific elements within a wayfinding environment, should always be simple, supplemental, limited in number and applied consistently and without exception. When too many colors are introduced, it will typically create an additional layer of information to decipher, which in turn may cause increased confusion, pause and distrust of the wayfinding system

Consideration of Colorblind Individuals:

- As of this document's publishing, approximately 12% of the population is colorblind and cannot distinguish between mixed shades of red or orange, yellow or brown and black or blue. For this reason, if multiple colors are to be used as a primary means of identifying wayfinding elements (i.e. "The Orange Line," "The Green Room," etc.), then it would be necessary to spell out the name of the color in order to make the intended color usage clear to colorblind individuals, while also meeting related ADA requirements

Color-Coding:

- Color-coding, when applied thoughtfully, sparingly and consistently, is a useful supplement to a good linguistic format. Color-coding should not typically be the absolute or primary means of distinguishing parts of a facility, and instead be used in a manner that supplements the primary graphic wayfinding information being presented. For example, applying a unique color to each individual level or area of a parking garage is a common practice among parking facility designers. However, the color use of such a color system must be considered within the larger context of the surrounding/nearby facilities and how it will effect their color coding systems. When too many varied colors and/or color systems are used, color becomes yet one more layer to decipher in an already complex hierarchy of wayfinding information

Recognition, Contrast, Reproduction and Environmental Considerations:

- Colors should always be chosen for their wide recognition, contrast/legibility, ease of manufacture/reproduction, as well as complementary to the established wayfinding system or surrounding environment. The long-term "survivability" of colors will also be dependent on surrounding weather and

environmental conditions (i.e. direct sunlight and ambient light gradually affects color systems over time, typically fading and usually accelerated due to unique or typical local weather conditions). As such, the choice and use of color should always be evaluated to some degree based on the geographic location of the wayfinding environment

2.5.3 COLOR APPLICATION GUIDELINES

DFW Wayfinding Color System: General Description

The DFW wayfinding system's color palette should always use a *supplemental* wayfinding specific color-coding system that accents and enhances the messaging, while also limiting the use of other branded and/or non-wayfinding related colors. In addition, all colors should be consistently and easily manufactured on signage, maintain good contrast with each other, and appear as a distinctive wayfinding-specific color palette that is easily recognized by the majority of wayfinding system users, regardless of location within the airport property.

General Color Application Guidelines and Standards

The following are general color guidelines and standards for use within the DFW wayfinding signage system (see Figure 2.5.1):

- Sign Graphics - All DFW Wayfinding Signage:
 - The primary sign face background and text colors for all wayfinding signage (vehicular and pedestrian) are White text/symbols on an DFW Wayfinding Blue (PMS 662C) background. These colors were chosen for their widely adopted implementation system-wide at DFW, their high contrast when incorporated within the multitude of DFW's varied wayfinding environments (both interior and exterior areas)
- Sign Graphics - Pedestrian Wayfinding Areas (i.e. terminals, curbsides, pedestrian-related parking areas):
 - The use of White text/symbols on a DFW Wayfinding Blue sign face background avoids competition with color schemes of other competing entities (concessions, airlines, etc..) and integrates well with the varying structural and architectural features found at DFW
- Sign Graphics - Vehicular Wayfinding Areas (i.e. roadways and vehicular-related parking areas)
 - Roadways: White text/symbols on TXDOT blue sign face background creates high contrast and greater legibility from a distance, while traveling at posted speeds; distinguishes the airport's wayfinding sign system from surrounding city, county or state road sign systems; serves to alert motorists that they are traveling within the airport's property limits, and more complex movements will occur in shorter distances; as a means of enhancing the visual queue of leaving the airport's property limits and entering the surrounding city roadway system, roadway directionals nearest to airport exit/property limit areas will utilize TXDOT green backgrounds and graphic formatting
 - Parking Garages: White text/symbols on DFW Wayfinding Blue sign face background creates holistic visuals with pedestrian wayfinding signage
- Branded Terminal Identification:
 - In order to identify the terminals as unique/separate facilities at DFW,

the terminals will be branded with symbols unique from the other standard wayfinding symbols by utilizing the following colors:

- Symbol field background = DFW Wayfinding Blue (PMS 662C)
- Terminal ID letters = White
- Symbol borders = DFW Gold (PMS 130C)
- Ground Transportation Identification (at curb areas):
 - Multi-color system as developed by Jacobs (see Figure 2.5.1)
- Inter-Terminal Transit Systems:
 - The Inter-Terminal transit systems (i.e. Skylink = secured area access/elevated tram system; Terminal Link = non-secured area access using curbside shuttles) at DFW will utilize the following colors:
 - Symbol field background = Orange (PMS 166C)
 - Symbol artwork = White
- Parking Garages Level Identification:
 - All parking garage levels will use the same level color-coding as adopted at Terminal A garage:
 - Level 1 = Red (PMS 186C)
 - Level 2 = Purple (PMS 2587C)
 - Level 3 = Yellow (PMS 108C)
 - Level 4 = Orange (PMS 158C)
 - Level 5 = Med. Blue (PMS 2727C)

Other Color Considerations

- Consistent and Holistic Application:
 - To remain effective, the DFW wayfinding color system must always be applied to all wayfinding system elements in a consistent and holistic manner airport-wide (roadways, parking, curbsides, ground transportation areas, terminals, etc.) and at all DFW facilities
- Supplemental Colors:
 - The addition of any/all supplemental colors must always be carefully considered during design of new airport areas and their respective signage design programs in order to determine how they will mesh with the overall established DFW color-coding and wayfinding systems.
 - All supplemental colors must be coordinated with/approved by DFW
 - All supplemental colors must always maintain all legibility and compatibility criteria as mentioned in this section, as well as any applicable ADA/Federal, State, Local Accessibility and Code Standards, and MUTCD/TXDOT requirements regarding color-use on signage
- Additional Use of Color:
 - Certain signs within the airport complex may employ the corporate colors of airlines, rental car agencies, concessionaires and other airport tenants as dictated and/or deemed appropriate by DFW
 - No other colors are to be used for DFW wayfinding signage or sign hardware used within DFW unless otherwise approved by DFW

Terminal Areas:

PAINT COLORS

P1 Blue Powder Coated to match 3M 7725-37 EC Sapphire Blue	P2 Silver Matthews Paint # MP30136 Brushed Aluminum, satin finish	P3 Orange (Skylink) To match Pantone 166C. Satin Finish	P4 White Matthews Paint # MP05317 Photopolymer Braille, satin finish	P5 Light Green (Exit) To match Pantone 368C. Satin Finish
P6 Safety Red Matthews Paint to match Pantone 485C, satin fin.				

DIGITAL PRINT COLORS

D1 Light Green (Exit) To match Pantone 368C	D2 Dark Green (Terminal Link) To match Pantone 347C	D3 Reflex Blue (Prearranged Limo) To match Pantone Reflex Blue C	D4 Light Yellow (Taxi) To match Pantone 102C	D5 Orange (Shared Ride) To match Pantone 165C
D6 Aqua (Rental Cars) To match Pantone 299C	D7 Grey (Courtesy Van) To match Pantone 431C	D8 Mustard (Remote Parking) To match Pantone 124C	D9 Red (Express Parking) To match Pantone 704C	D10 Blue (DFW Valet) To match Pantone 301C
D11 Purple (Public Transit) To match Pantone 676C	Note: Typical Non-glare Overlaminated			

VINYL COLORS

V1 Blue 3M™ EC 7725-37 Sapphire Blue	V2 White 3M™ 7725-20 Opaque Matte White	V3 Yellow 3M™ 3630-25 Sunflower	V4 Light Green (Exit) To match Pantone 368C Opaque with Matte finish	V5 Black (Exit / Door Numbers) 3M™ 7725-22 Opaque Matte Black
V6 Safety Red To match Pantone 485C Opaque with Matte finish	V7 White 3M™ 4090 DG3 White	V8 Yellow 3M™ 4091 DG3 Yellow	V9 Blue 3M™ 4095 DG3 Blue	V10 Light Gray To match PMS Cool Gray 1C Opaque with Matte Finish

Garage Areas:

L1 (aka Level 1) Red = PMS 186C	L2 (aka Level 2) Purple = PMS 2587C	L3 (aka Level 3) Yellow = PMS 108C	L4 (aka Level 4) Orange = PMS 158C
L5 (aka Level 5) Blue = PMS 2727C	L6 (aka Level 6) Terminal D Only: White	LL1 (aka Lower Level 1) Terminal D Only: Green = PMS 368C	LL2 (aka Lower Level 2) Terminal D Only: Pink = PMS 204C
P1 Blue TIGER Drylac powder coat #PLSF21528P	V7 White 3M™ 4090 DG3 White	D12 Blue Digital print to match P1	

Curbside/Ground Transportation Areas (2017 New Adopted Jacobs-Developed Color System):

POWDERCOAT COLORS

C1 Blue TIGER Drylac #PLSF21528P	C2 Silver Metallic TIGER Drylac #38/31020	C3 Blue Powder Coated to match
--	---	---

PAINT COLORS

P1 Blue Matthews Acrylic Polyurethane Match Pantone 287C	P2 Silver Metallic Matthews Acrylic Polyurethane MP30136 "Brushed Aluminum"
--	---

DIGITAL PRINT COLORS

UL1 Pantone Reflex Blue C	LL1 Pantone Cool Gray 10	LL6 Pantone 287 CP
UL2 Pantone 166 CP	LL2 Pantone 5265 CP	LL7 Pantone 347 CP
UL3 Pantone 102 C	LL3 Pantone 631 CP	LL8 Pantone 676 C
UL4 Pantone 347 CP	LL4 Pantone P 88-8C	
UL5 Pantone 704 CP	LL5 Pantone 130 CP	

VINYL COLORS

V1 3M EC 7725-37 Sapphire Blue	V5 3M EC 7725-15 Bright Yellow	V9 ARLON 2100-42 Cardinal Red
V2 3M EC 7725-77 Peacock Blue	V6 ARLON 2100-58 Dark Magenta	
V3 3M EC 7725-14 Bright Orange	V7 3M EC 7725-186 Bright Green	
V4 3M EC 7725-38 Royal Purple	V8 3M EC 7725-64 Apricot	

GROUND TRANSPORTATION COLORS/SYMBOLS APPLIED

Terminal Link Background: PMS 166C Symbol: PMS166C/White	Pre-Arranged Limo Background: PMS Reflex Blue C Symbol: PMS Reflex Blue C/White	Taxi Background: PMS 102C Symbol: PMS 102C/Black
Rental Cars Background: PMS 5265C Symbol: PMS 301C/White	Courtesy Vans Background: PMS 254C Symbol: PMS 254C/White	Remote Background: PMS 130C Symbol: PMS 130C/Black
Charter Bus Background: PMS 186 C Symbol: PMS 186 C/White	Passenger Pick Up & Drop Off Background: PMS 347C Symbol: PMS 347C/White	Express Background: PMS 631C Symbol: PMS 631C/White
Shared Ride Background: PMS 704C Symbol: PMS 704C/White	Valet DFW Valet Background: PMS Cool Gray 11C Symbol: PMS 165C/White	On-Demand Limo Background: Neutral Black C Symbol: Neutral Black C/White
Employee Background: PMS Cool Gray 11C Symbol: PMS Cool Gray 11C/White	Rail Background: PMS 662C Symbol: PMS 287C/White	Ride App Background: PMS 7461 C Symbol: PMS 7461 C/White
Off Airport Valet Background: PMS 284 C Symbol: PMS 284 C/White/Neutral Black C	Grand Hyatt Valet Background: PMS 7418 C Symbol: PMS 7418 C/White	Corporate Aviation Background: PMS Cool Gray 11C Symbol: PMS Cool Gray 11C/White

Figure 2.5.1 DFW Wayfinding Color System

2.6 ART, ADVERTISING AND AMENITIES

2.6.1 OVERVIEW

NOTE: Design standards for art, advertising and amenity signage is not covered within this document; see the most recent editions of DFW art, advertising and amenity design standard documentation for all applicable requirements.

Airports typically have several elements and systems that compete with pedestrian wayfinding signage. These include (but may not be limited to) art, advertising and amenity related signage. Consistent and sensible location of wayfinding signage in relation to each of these elements will ensure an effective and positive wayfinding experience. This section provides general guidelines and recommendations for effective placement of wayfinding signage in relation to these other nearby elements.

General Placement Guidelines

DFW "Wayfinding Signage Philosophies" place a priority on ease of wayfinding throughout all of its facilities. As a result, the DFW wayfinding system will typically take visibility and placement priority over other nearby systems such as art, advertising and amenity elements. However, it must also maintain general harmony with regards to visibility and general placement in relation to these other nearby systems. The following general guidelines have been established and should be used by all designers specifying wayfinding signage within DFW airport facilities.

Placement of wayfinding signage in relation to art, advertising and amenity elements shall always be done so in a manner that maximizes the visibility of each without obstructing important wayfinding information. As such, a simple grid system should be used by designers to maximize the placement of each element. This grid system is based on a simple X/Y/Z axis system (i.e. X = horizontal axis; Y = vertical axis; Z = third-dimension axis, or "forward/backward" in relation to the viewer's position).

The following are general guidelines to be used as a reference for placing wayfinding signage in relation to art, advertising and amenity elements (see Figure 2.6.1):

- Typical Vertical Placement:
 - Vertical placement of wayfinding signage and nearby elements will use an established set of three-dimensional spatial zones along the Y-axis plane and extend forward/backward along the Z-axis plane
- Typical Horizontal Placement:
 - Horizontal placement of wayfinding signage and nearby elements will use an established set of three-dimensional spatial zones along the X-axis plane and extend forward/backward along the Z-axis plane

Signage Zones

Basic placement zones have been provided here for locating DFW wayfinding signage in relation to art, advertising and amenity related elements (see Figure 2.6.1). The following general guidelines should be utilized when locating wayfinding signage near these elements (Note: A.F.F. = "above finished floor"):

- Overhead Wayfinding Zone: is a +/- 3'-0" high three-dimensional spatial

plane dedicated to placement of overhead pedestrian wayfinding signage

- Typical vertical zone size = +/- 8'-6" A.F.F. to 11'-6" A.F.F.
 - Note that the zone may also extend above or below these dimensions if deemed appropriate for a given location's conditions and requirements
- The line-of-sight for this zone should always maintain an unobstructed view of 50'-0" minimum on the Z-axis plane approach.
- Amenity Zone: is a +/- 2'-6" high three-dimensional spatial plane that applies to placement of signage and/or elements for amenities (i.e. restaurants, taverns, retail shops, concessions, etc.)
 - Typical vertical zone size = +/- 6'-8" A.F.F. to 8'-6" A.F.F.
 - Placement of amenity elements within this zone are dependent upon established DFW amenity signage design standards and per individual terminal facility conditions; wayfinding signage should typically maintain a +/- 10'-0" min. horizontal perimeter away from amenity signage/elements whenever possible
- Lower Wayfinding/Art & Advertising Zone: is a +/- 6'-8" high three-dimensional spatial plane that applies to placement of lower wayfinding signage (i.e., floor mounted and lower wall mounted sign types), as well as

concessions, art and advertising elements typically scaled for more personal interaction/viewing

- Typical vertical zone size = Finished Floor to +/- 6'-8" A.F.F.
- Art, advertising and freestanding concession elements in this area should typically maintain a horizontal perimeter of +/- 10'-0" min. from wayfinding elements whenever possible
- Overhead Art & Advertising Zone: Note that overhead art & advertising requires flexibility in sizing and spacing and is preferred to occur above the Overhead Wayfinding Zone whenever possible (typically above 11'-6" A.F.F. or as deemed appropriate for a given location's conditions or sizing requirements, and is dependent on individual terminal facility conditions)

NOTE: Dimensions shown here are to be used as a general guideline only; some overlap of zones is to be expected and may occur depending on unique terminal environment conditions and sizing of wayfinding signage and existing/planned art, advertising and amenity elements; no art, advertising or amenity elements will be placed within limits of wayfinding signage or attached to wayfinding structure; designers are required to review all wayfinding signage in relation to art, advertising and amenity elements as location conditions require, and adjust placements as necessary.

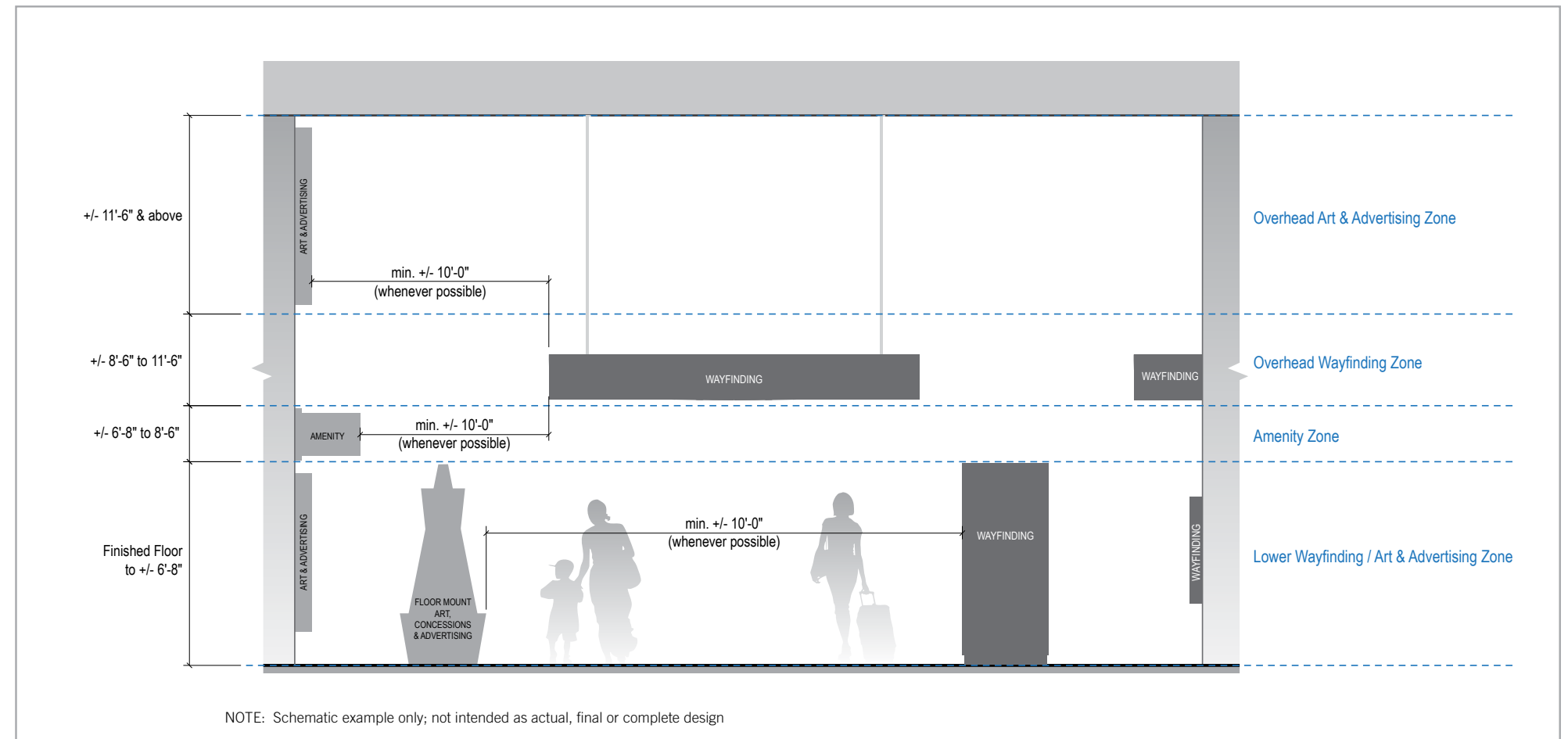

Figure 2.6.1

Typical Signage Zones

WARNING:

This record contains Sensitive Security Information that is controlled under 49 CFR parts 15 and 1520. No part of this record may be disclosed to persons with a "need to know," as defined in 49 CFR parts 15 and 1520, except with the written permission of the Administrator of the Transportation Security Administration or the Secretary of Transportation. Unauthorized release may result in civil penalty or other action. For U.S. government agencies, public disclosure is governed by 5 U.S.C. 552 and 49 CFR parts 15 and 1520.

2.7 ILLUMINATION

2.7.1 OVERVIEW

Ambient light conditions will always have an effect on a sign's visibility and legibility. The effectiveness of a wayfinding system is greatly dependent on the ability of wayfinding traffic to decipher a sign's graphics in a multitude of varying light levels and conditions as found within an airport's interior and exterior environments. Lower ambient light levels typically have adverse effects on message comprehension, which in turn may cause increased levels of stress and distrust of the overall wayfinding system. As such, illumination considerations and implementation are an extremely critical aspect of wayfinding signage.

Methods of Illumination

There are several different types of illumination that can be used on wayfinding signage, each with their own advantages and challenges. The following are examples of typical wayfinding signage illumination types:

- Non-Illuminated:
 - Completely reliant on ambient/nearby light conditions.
 - In lower light conditions, distinguishing a sign's forms or graphics from the surrounding environment is greatly diminished (note that a sign's visibility/legibility/contrast may not meet minimum ADA requirements if ambient light conditions are too low)
 - Can be more difficult to distinguish signage forms and/or decipher graphics when located near brightly lit background environments (i.e. near exterior-facing windows during daylight hours)
 - Thinner sign profiles and generally lighter weight fabrication methods can be employed, typically resulting in lower initial fabrication costs
- External Illumination (aka "Front-lit"):
 - Reliant on the quality, intensity and proximity of nearby light sources.
 - Forms and graphics on interior signs do not stand out from surrounding environments as well when located in higher ambient light areas
 - Typically suffer from inconsistent visual presentation due to increased possibility of hot/dark spots across sign face/elements
 - Requires nearby power sources be installed or in place prior to install.
 - Thinner sign profiles and generally lighter weight fabrication methods can be employed, typically resulting in lower initial fabrication costs
- Reflective Illumination
 - Reliant on the quality, intensity, direction and distance of light sources focused specifically at the reflective face area of a sign
 - Typically employed more frequently on vehicular signage as a means of cost effective illumination, as well as meeting associated MUTCD/TXDOT standards and requirements
- Internal Illumination (aka "Back-lit"):
 - Not reliant on ambient light conditions
 - Very good visibility in low or high ambient light conditions
 - If designed and implemented properly, will typically always meet ADA sign requirements regarding visibility/legibility/contrast
 - Greatly enhances the ability to read and distinguish wayfinding signage forms and graphics from the surrounding environment

- Requires nearby power sources be installed or in place prior to install
- Can be more expensive initially due to associated costs with chosen illumination technologies.
- Signage weight and profile thicknesses tend to be increased due to internal space requirements for illumination system components and added structural elements.

Illumination Guidelines and Standards - DFW Wayfinding System

DFW wayfinding signage will always utilize consistent and standardized illumination methods. This will enhance and provide holistic visibility and legibility across the overall wayfinding system, while also meeting applicable ADA and MUTCD/TXDOT requirements for wayfinding signage.

At the time of this document's publication, final universal illumination implementation standards for the DFW wayfinding system are still in discussion and development with DFW. However, in the interim and for the purposes of general design intent, the following recommended guidelines and standards for illumination implementation shall be used whenever designing and/or specifying DFW wayfinding signage.

Note: These recommendations are based on wayfinding industry typical best practices at time of this document's publication, & may change in the future as advancement of illumination technologies occur.

- Interior Pedestrian Signage:
 - Primary/preferred method = use internal illumination whenever possible.
 - When ambient lighting conditions are high, internal illumination still provides a benefit by making a sign's forms and graphics much more immediately visible/noticeable against competing environmental elements (see Figure 2.2.2a for conceptual design intent details and information regarding the recommended application of modern internal illumination technology within the DFW wayfinding system)
 - Modern internal LED illumination technology has several advantages when compared to conventional illumination methods (such as neon or fluorescent technologies)
 - Lower energy use and maintenance resulting in lower up-keep and power consumption costs over time
 - Lighter weight sign fabrication methods resulting in thinner cabinet profiles/projections, which also allow for much more aesthetically attractive and less visually imposing signage
 - When properly specified and implemented, LED edge lighting distribution is typically consistent and even across the entire sign face, while also typically eliminating hot/dark spots
 - Heat build-up is lessened and dissipation is much more efficient, typically resulting in extended illumination life expectancy
 - Secondary method = use non-illuminated sign fabrication
 - Use external illumination via nearby or dedicated lighting sources whenever possible; see Figure 2.2.3b for conceptual design intent details and information regarding the recommended non-illuminated fabrication

- Exterior Pedestrian Signage:
 - Primary/preferred method = use internal illumination whenever possible, or where it's most beneficial and/or required (i.e., within parking garages and/or under architectural covers where ambient lighting conditions vary radically the closer/further signage is located in proximity to the projection of daylight)
 - Secondary method = use external illumination via nearby or dedicated lighting sources when internal illumination is not viable or possible.
 - Use reflective graphics when nearby or dedicated lighting sources are not available
- Vehicular Signage - Roadways and Parking Garages/Lots:
 - Primary required method = on all overhead and roadside wayfinding signage, always use highly reflective sign face graphics by utilizing products such as 3M's DG3 line of reflective roadway sign films
 - Specialized applications = use internal and/or external illumination on specialized signage, such as Airport property entrance gateways and architectural/building identification as applicable
- Vehicular Signage - Curbsides:
 - Primary/preferred method = use highly reflective sign face graphics by utilizing products such as 3M's DG3 line of reflective roadway sign films.
 - Secondary method = use internal illumination for other specialized signage at terminal curbsides (i.e., curbside airline/meeting place ID)

General Illumination Requirements

- Illumination methods and usage not described here shall not be used at DFW, unless otherwise noted and approved by DFW Planning Department
- When *internal* illumination is used:
 - Illumination levels shall be uniform over the entire sign face surface
 - No hot spots, dark spots or inconsistent/varying levels of illumination are allowed. Signs shall always be located such that the illumination level on the readable surfaces is not significantly exceeded by the ambient light or additional visible sources of light behind or in front of the sign
- When *external* illumination is used:
 - Illumination levels on sign surfaces shall be in the 100 to 300 lux range (10 to 30 foot candles) and shall be uniform over the entire sign surface.
 - No hot spots, dark spots or inconsistent/varying levels of illumination are allowed. Signs shall always be located such that the illumination level on the readable surfaces is not significantly exceeded by the ambient light or additional sources of light behind or in front of the sign
 - Elements casting illumination from external sources (i.e. external attachments/housings/etc. for directed lighting) shall not block visibility of the sign or cast distracting shadows upon the sign's readable areas.
- When *non-illuminated* is used:
 - When located near other internally illuminated signs, Terminal ID colors on non-illuminated signs will require custom color matched paint to create color consistency across all wayfinding signage

WARNING:

This record contains Sensitive Security Information that is controlled under 49 CFR parts 15 and 1520. No part of this record may be disclosed to persons with a "need to know," as defined in 49 CFR parts 15 and 1520, except with the written permission of the Administrator of the Transportation Security Administration or the Secretary of Transportation. Unauthorized release may result in civil penalty or other action. For U.S. government agencies, public disclosure is governed by 5 U.S.C. 552 and 49 CFR parts 15 and 1520.

2.8 WAYFINDING SIGN SYSTEM OVERVIEW

2.8.1 OVERVIEW

The wayfinding sign system shown in this document represents a generally holistic system being implemented throughout all DFW facilities. The DFW wayfinding sign system should always be consistent in appearance and application throughout the entire airport area in which it is being applied. Doing so consistently will establish a public perception that DFW is a professional and forward-thinking organization, which will always be apparent within any of its amenities or facilities.

Design Description – DFW Wayfinding Signage System

The DFW wayfinding signage system should continue to be developed to make all airport wayfinding signage an extension of DFW's world-class branding and philosophies. It should meet the established principles of DFW's general mission and vision for wayfinding. The following should be universally adopted at all DFW facilities:

- Provides safe, efficient and appealing wayfinding at all DFW Airport facilities
- Reinforces DFW as an airport standard of excellence within the United States, as well as the world
- Unifies signage as one holistic wayfinding system, both interior and exterior
- Shares a consistent, positive “tone-of-voice” at all DFW areas and facilities
- Creates a consistent and shared “sense of arrival” and a “sense of place” at each Airport area and facility

These same principles will always be used for all wayfinding signage implemented within any of DFW's modernization programs.

Sign System Objective: Pedestrian Signage

The general objective of the Pedestrian related wayfinding sign system should be to direct the flow of pedestrian traveler traffic at curbside/ground transportation areas, in and out of the public terminal entrances, between appropriate designated terminal areas, in/out of the concourse/gate holdroom or CBP passenger processing areas, and within pedestrian related areas of parking garage facilities. This is achieved by using a hierarchy of signage that relates specifically to pedestrian traffic, and should be designed with appropriately sized graphics, visual queuing elements, orientation and placement for such traffic.

Sign System Objective: Vehicular Signage

The general objective of the Vehicular wayfinding sign system should be to direct the flow of vehicular traffic in and out of DFW, as well as throughout its various public-use facilities (i.e. to/from parking facilities, terminal curbs, service areas, etc.). This is achieved by using a hierarchy of signage that relates specifically to vehicular traffic, and should be designed with appropriately sized graphics, visual elements/features, orientation and placement for such traffic.

Special Areas

Some areas of the DFW do not necessarily fall within a specific category, and as such are identified as special areas. A special area should be specifically designed for and reviewed/approved by DFW Planning on a case by case basis as needs require. Examples of special areas may include (but are not limited to) public art, advertising and concession related signage.

Interim (Temporary) Signage

Sign types developed for temporary/interim conditions shall also use the standards and guidelines for permanent wayfinding signage as shown in this document as a baseline for matching the rest of the wayfinding system.

Exceptions

To be successful, a signage program must allow for flexibility. Exceptions to any of the general signage standards and guidelines listed within this document should be reviewed on a case-by-case basis, and enforced by DFW as deemed necessary and appropriate.

2.8.2 SIGN TYPES – GENERAL OVERVIEW

There are several elements that make up a clear and recognizable sign. Even though the message and its copy size/clarity are of great importance, so too is the actual sign entity that it is placed on. Having consistent and distinct sign types enhances a sign system by being more recognizable to its users within unfamiliar environments. Many travelers can decipher the type of information that will be given based on the size, shape, mounting location or color of the sign. This shortens the decision-making process, creating smoother traffic flow and increased trust in the overall wayfinding system.

Sign types will typically be used based on their message priority and basic function:

- Primary Signs Types: signs used for priority destinations/functions of the airport are considered “Primary” signage, and should be the most visible and visually dominate to other wayfinding signage
- Secondary Sign Types: secondary messaging (such as Telephones, ATM, etc.) should typically be reserved for sign types pre-determined as “Secondary” in nature, and should appear visually subordinate to the Primary signage
- Tertiary Sign Types: tertiary messaging (such as regulatory, safety related information, etc.) should also be placed on sign types pre-determined for “Tertiary” use, and should appear visually subordinate to both Primary and Secondary signage

Wayfinding Sign Family

DFW's wayfinding system should use a comprehensive sign typing system that is based on categories of a sign's function. In some regards it has been developed into a holistic family of signs with each member having their own specific use and purpose, while also utilizing a “kit-of-parts” design philosophy. It should be designed as manageable, and allow for being seamlessly integrated within all DFW facilities, while being updated on a continuing basis as needs arise.

Wayfinding sign types at DFW should be categorized as directional, identity, informational, regulatory/warning, room labels and tags. Major sign type classifications (as categorized by function) and general descriptions of each should include:

- Directional: signs that display standardized directional messaging to assist in finding one's way through a defined area or environment (i.e. an overhead sign at a decision point with arrow/symbol/destination messages listed)

- Identification: signs used as unique markers to identify specific locations within a defined area or environment (i.e. a gate identification sign)
- Informational: signs or graphic systems that display specific and very detailed information to assist in orientation within a complex or unfamiliar environment (i.e. a directory map or FIDS)
- Regulatory: signs that display regulatory information (i.e. “No Parking” or “Loading Zone Only” signs)
 - Note: not included as part of this document
- Life-Safety/Egress: signs that display life-safety and vertical circulation/egress related information as required by local and national codes (i.e. fire escape stairway core level identification signs)
 - Note: not included as part of this document
- Interim (Temporary): signs that can be directional, identification, informational and regulatory, but are made of temporary materials and mounting methods
 - Note: not included as part of this document

The following wayfinding sign families are included within this document:

- Terminals/Gate Areas (see Chapter 3.0)
- Curbside/Ground Transportation Areas (see Chapter 4.0)
- Roadway Areas (see Chapter 5.0)
- Garages/Parking Areas (see Chapter 6.0)

Note: All sign types shown in this document are intended as general design intent only; Sizes shown are typical only; terminal/garage/roadway conditions vary and may require adjustment for final design of sign type sizing/proportions/ etc.; additional sign types not shown in this document may be required as determined during design processes of individual DFW improvement programs.

Scale and Sizing

Scale and sizing for all DFW wayfinding signage will be consistent and designed to the appropriate required viewing distances for a given condition or environment, as well as to the minimum ADA and/or MUTCD/TXDOT requirements, as well as all code requirements.

Note that the sign types shown are for typical conditions only and are designed to accommodate minimum ADA and MUTCD/TXDOT requirements (i.e., minimum 3” capital height letters on pedestrian overhead signs at approximately +/- 8'-0” above finished floor to bottom of sign). Adjustments to the scale and size of certain sign types may be necessary to maximize visibility and aesthetic harmony within a given wayfinding condition or environment during design development. As such, all designers specifying wayfinding signage for use at DFW will review all individual spatial and environmental conditions per each area of scope, and make recommendations for scale/size adjustment as deemed appropriate.

2.8.3 SIGN TYPE IDENTIFICATION SYSTEM - RECOMMENDED

The vast amount of differing architectural and site conditions at DFW airport facilities, combined with the fact that a standardized sign type identification system doesn't currently exist, creates a need for a comprehensive and holistic sign identification system. This ID system should always maintain standardization, flexibility and ease-of-understanding for the majority of individuals specifying and programming updated and new wayfinding signage at DFW. It is recommended that all DFW wayfinding signage be grouped into the following categories:

- Pedestrian Signs (*NOTE: Certain vehicular signs also fall within these Series numbers)
 - Series 1: Terminals / Concourses: Includes all public-accessible Terminal and Concourse related areas
 - Series 2: CBP Required Signage: Includes: Areas as controlled by the U.S. Customs and Border Protection
 - *Series 3: Curbside / Ground Transportation: Includes: All Curbside and Ground Transportation related areas
 - *Series 5: Parking: Includes: All on-property public-accessible garages and surface lots
- Vehicular Signs
 - Series 4: Roadways: Includes: All on-property public-accessible roads
- Other Areas
 - Series 6: Support Facility Areas
 - Series 7 (and above): Are to be assigned as needed and based on unique requirements of individual projects. Note that all expanded series numbering and categorization must be coordinated with DFW Planning Department for final approval

Pedestrian vs. Vehicular Sign Identification Systems

Pedestrian and vehicular wayfinding signage should always use similar sign type numbering and categorization methods to maintain a holistic identification system across the entire wayfinding program (see Figure 2.8.1). However, each traffic type also has unique requirements and/or mounting configurations associated with them. As such, the identification system is more effective when supplemental designators are applied to their respective systems as needed.

Roadway Signage - Unique Mounting Designator

See Figure 2.8.1, "Roadway Signage Mounting Designator" detail for a general description of the unique designator that should to be applied to all DFW roadway wayfinding signage, as well as how to use it for roadway signage identification (see also Figure 1.4.2b for additional information regarding recommended roadway signage location annotation standards).

Variant/Option Designator

When a sign type requires a variant or option (due to sizing variations, directional end-facing, etc.), a unique designator using a lowercase letter at the end of the sign number should be used. For example, a wall mount directional sign type "1-DR.23" is designed for a left-justified directional layout/accent trim. However, when a right-justified layout is required, the accent trim must appear on the right side. In this instance, "1-DR.23b" would be used to designate the right-facing variant.

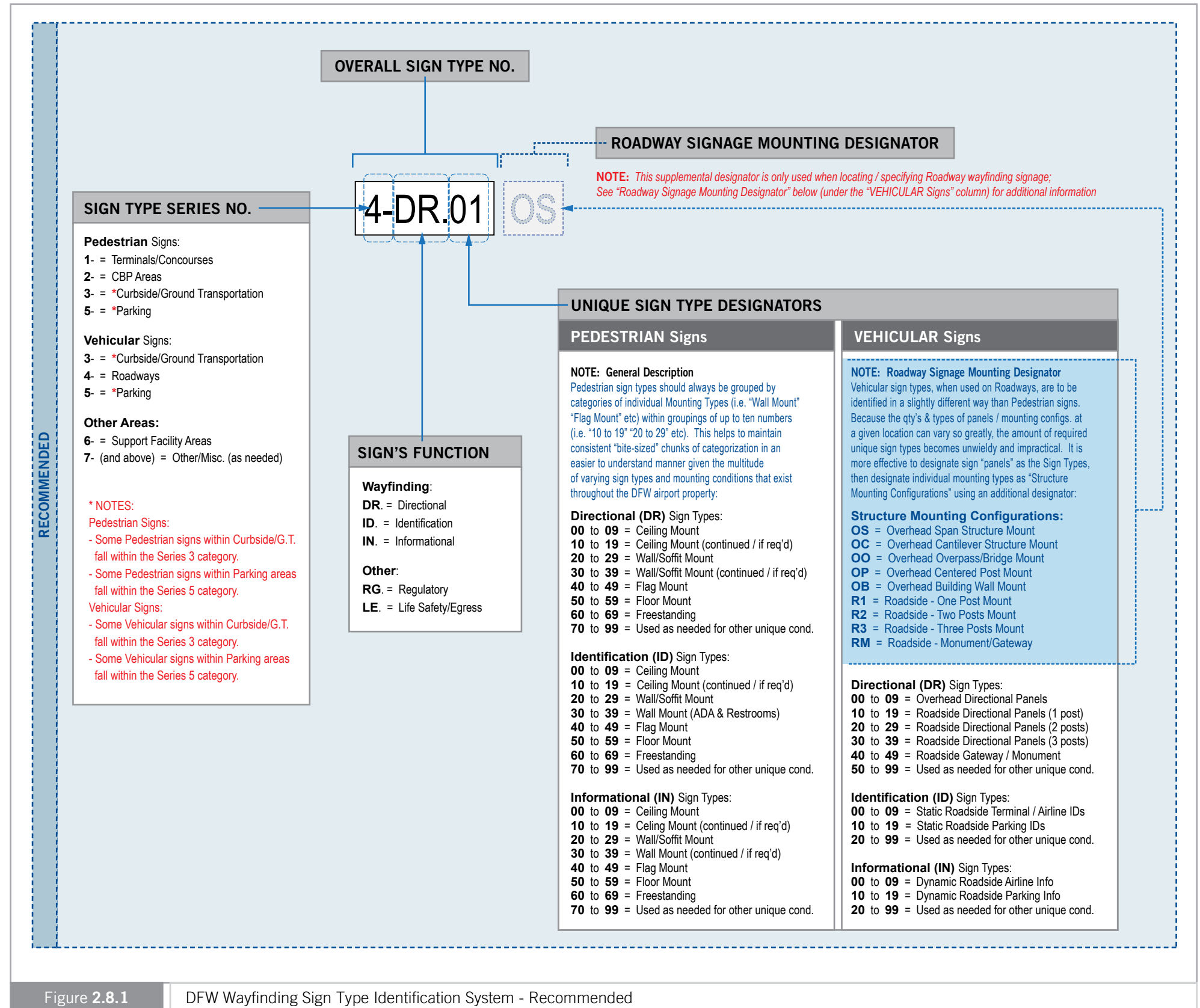

Figure 2.8.1

DFW Wayfinding Sign Type Identification System - Recommended

3.0

3.0 SIGN TYPES - TERMINALS/GATE AREAS

- 3.1 Sign Type Index
- 3.2 Sign Types

SIGN TYPE INDEX - TERMINALS/GATE AREAS

This chapter provides specific information regarding the wayfinding sign types applicable for use in the Terminals/Gate areas of DFW Airport. It contains a general sign family overview of the specific sign types (i.e., the Sign Type Index section), as well as more specific design/layouts/notes/etc for each individual sign type (i.e., the Sign Types section).

On the following pages, the Sign Type Index shows simple views of each sign type, as well as listings for each sign type's name, mounting method and basic overall size. Note that the Sign Type Index is intended only as a brief, simple catalog for all of the wayfinding sign types used within the Terminals/Gate areas of DFW, and is organized in numeric order of their sign type identification numbers (i.e., Directional sign type category: 1-DR.01, 1-DR.02, etc; Identification sign type category: 1-ID.01, 1-ID.02, etc; Informational sign type category: 1-IN.01, 1-IN.02, etc).

Sign Types - Design Intent Drawings

Section 3.2 - Sign Types contains design intent drawings of each specific wayfinding sign type used within the Terminals/Gate areas of DFW Airport. Each sheet displays scaled drawings of individual sign types and their basic views (i.e., elevations, plan views, end view, etc), sizing/dimensions, face layouts and general design intent related notes.

NOTE: these documents are intended to illustrate design intent, and should only be used as a general guideline. No information contained here should be construed as engineered elements. The designer/fabricator/contractor shall be responsible for all engineering and specifications with regard to structural, electrical, mechanical, foundation and installation. Details and information contained in this document shall not be reproduced, copied or utilized in any way except for the specific project for which they were created without previous written authorization from DFW Planning Department.

Mounting Requirements

Sign mountings shall support signs for optimum visibility, facilitate illumination where required, be fabricated from commonly available materials, be easily maintained, be engineered to established DFW wayfinding system and engineering requirements, and not obstruct or pose any hazard to pedestrians, vehicles or any other entity.

Basic Mounting Types

The basic mounting types used within DFW's Terminals/Gate areas are as follows:

- Ceiling Mount:
 - Suspended: Overhead signs located in high ceiling areas mounted with a suspension system mechanically attached to the sign's top most element and at the top of the suspension system, with the overall suspension system/sign attached to an above-ceiling structural support system
 - Flush Top: Overhead signs mounted in lower ceiling areas with the sign's top most element flush to the ceiling using a mechanical fastening system attached to an above-ceiling structural support system
- Wall/Soffit/Fascia Mount: Signs that are located on a vertical architectural fascia (overhead) or wall (overhead or pedestrian eye-level), and mechanically attached to the fascia/wall's internal vertical structure
- Wall Mount - ADA/tactile plaques: Signs with tactile features that are mounted to walls, doors or other required elements to meet local/ADA accessibility requirements and codes for accessible design and use
- Flag (Blade) Mount: Overhead signs mechanically attached on one vertical edge to internal structural elements of vertical architectural surfaces (i.e., walls, columns, etc) in a "flag-like" configuration
- Floor/Ground Mount: Non-moveable signs mechanically attached directly to structural elements of an architectural floor or in-ground structural mounting methods
- Freestanding (Moveable): Signs that utilize freestanding, non-attached base configurations, typically with wide and weighted footer features (to eliminate accidental tipping over); allow for flexibility in moving a sign as changing location conditions require

General Mounting Requirements/Restrictions - Pedestrian Signs

- All overhead pedestrian signs shall be mounted at a minimum of 8'-0" to a typical maximum of 9'-0" above finished floor to the bottom of the lowest element of the sign, unless otherwise indicated
- ADA accessibility and code required signage shall be mounted in accordance with all applicable code requirements using the most recent edition of the codes and regulations
- Whenever there is a conflict between a requirement listed in this document and another authoritative code or standard, the more stringent one shall be applied

WARNING:

This record contains Sensitive Security Information that is controlled under 49 CFR parts 15 and 1520. No part of this record may be disclosed to persons with a "need to know," as defined in 49 CFR parts 15 and 1520, except with the written permission of the Administrator of the Transportation Security Administration or the Secretary of Transportation. Unauthorized release may result in civil penalty or other action. For U.S. government agencies, public disclosure is governed by 5 U.S.C. 552 and 49 CFR parts 15 and 1520.

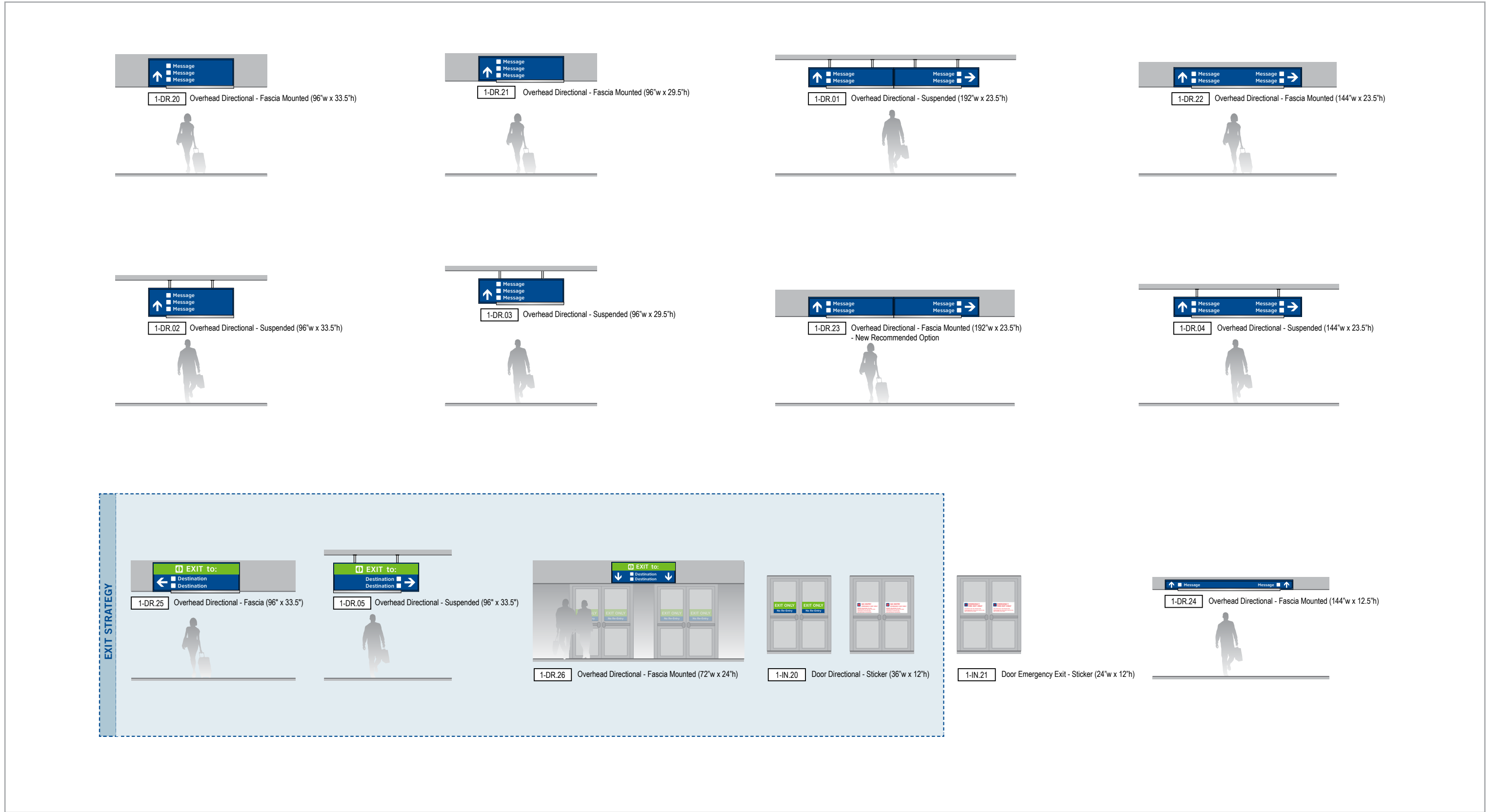

Figure 1.1.8 DFW Wayfinding Sign Family: Terminals/Gate Areas

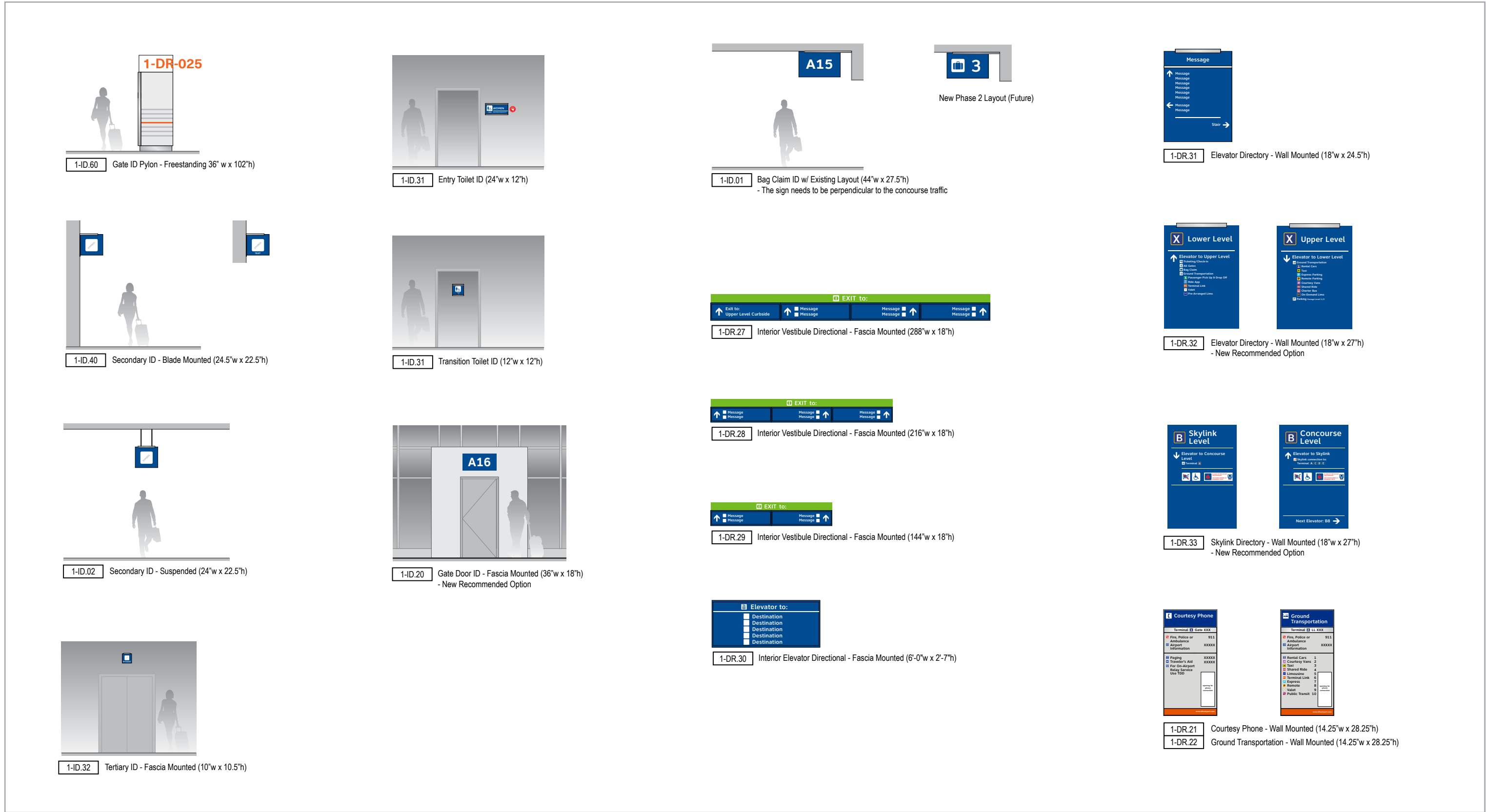

Figure 1.1.8

DFW Wayfinding Sign Family: **Terminals/Gate Areas**

ILLUMINATION	SIGN TYPE	SIGN FUNCTION	MOUNTING METHOD	GENERAL DESCRIPTION & USE
INTERNAL	1-DR.20 / 1-DR.25	DIRECTIONAL	FASCIA MOUNT	Overhead Directional

GENERAL NOTES

- All final design, engineering, and amount/sizing of structural sign support elements, material types/thicknesses, dimensions, and attachment methods shall be performed and approved by a licensed engineer to meet or exceed all applicable local and national codes.
- Final engineering, dimensions, materials, and fabrication are the responsibility of the Fabricator to ensure the highest quality fit and finish for all components of the completed product. All final detailing and specifications to be provided by the Fabricator within their final approved fabrication-ready shop drawings.
- Wherever dissimilar metals are in contact, always separate contact surfaces prior to assembly or installation with the necessary protective coatings/gaskets/washers to prevent galvanic corrosion.
- Final fabrication methods, quality and fit/finish to be reviewed and approved by DFW Airport Planning Department and wayfinding/architecture Design Consultants thru prototype reviews prior to final production run/installation processes (see Performance Specifications for details).
- Colors shown are for reference only, and are subject to the limitations of the printing process and/or variance of electronic RGB screen displays. Refer to color system swatches and/or final finish samples for accurate reference.
- Messages shown here are general placeholders only. See graphic message schedules for specific messaging by location and sign type.

FABRICATION INTENT NOTES

- F1** SIGN CABINET/FRAME: modular fabricated internal illuminated edge-lit sign module cabinet constructed of extruded aluminum and cast aluminum components with concealed internal welds; removable sign face and light modules; fabricated aluminum support frame with welded mitered corners and slotted mounting holes to accept sign mounting brackets; fabricated alum. sign mounting frame with tapered side end cover panels, attached with aluminum pin and clip system; power feed/units hidden behind mounting frame with access holes in back for wall mounting; powdercoat all exposed surfaces of sign cabinet/support frame/mounting frame to match P1 satin finish
- F2** SIGN FACE: fabricated sign face assembly module constructed of extruded aluminum frame and concealed internal welds; faces are 3/16" white acrylic with 1st surface applied V1 vinyl film, graphics reversed out of blue (white is exposed white acrylic cut-thru blue film); faces illuminated with light panel assembly using LED edge-lit clear inscribed acrylic diffuser and self-contained technology (including electronics, extruded frame and diffuser)
- F3** TRIM: .080 fabricated alum. trim piece with closed ends; detachable and mounted with keyholes/studs and set screws; paint all exposed surfaces to match P2, satin finish
- F4** MOUNTING: mount to hidden above-ceiling structural elements with connection system as installation location conditions require (Fabricator to coordinate connection location/type of structural elements with General Contractor); 2" diameter aluminum suspension tube supports with 4" diameter 3/16" aluminum escutcheon cover plate at ceiling connection point, paint all exposed surfaces to match P2, satin finish; attached to sign support frame with weld applied flanges and mechanical fasteners

GRAPHICS / COLORS / DECORATION NOTES

- L1** Typeface: font = ClearviewText Medium
- S1** Universal Symbols: AIGA style symbol artwork
- S2** Arrow(s): use only official DFW Airport wayfinding arrow artwork
- VINYL (FILM):**
- V1** Blue: 3M EC 7725-37 Sapphire Blue
- V2** White: 3M 7725-20 Opaque Matte White
- V3** Skylink Yellow: 3M 7725-114 Enamel Receptive
- PAINT:**
- P1** Blue: Powder coated to match 3M EC 7725-37, satin finish
- P2** Silver: MAP paint # MP30136, satin finish

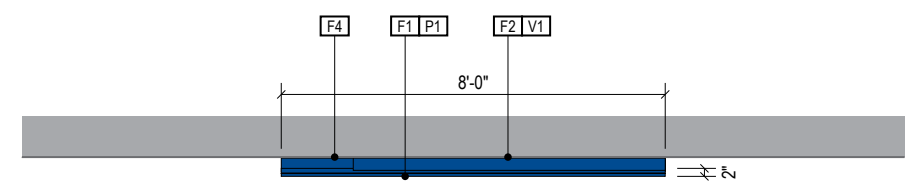

1 PLAN VIEW
Scale: 1/4" = 1'-0"

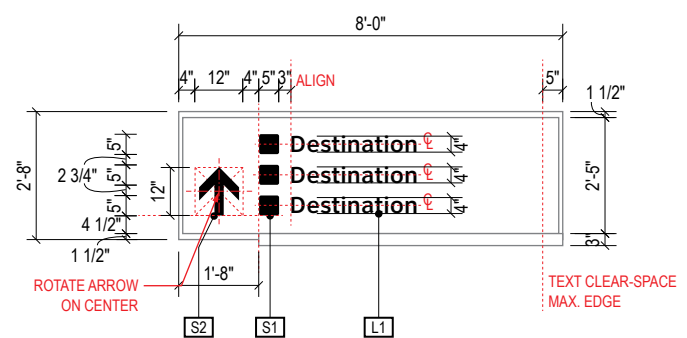

A DETAIL A: Face Layout
Scale: 1/4" = 1'-0"

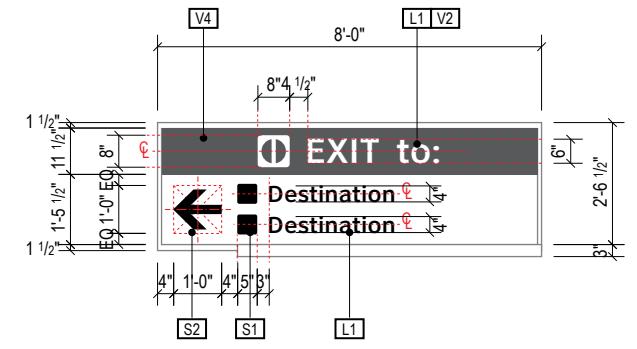

B DETAIL B: Alternate Face Layout
Scale: 1/4" = 1'-0"

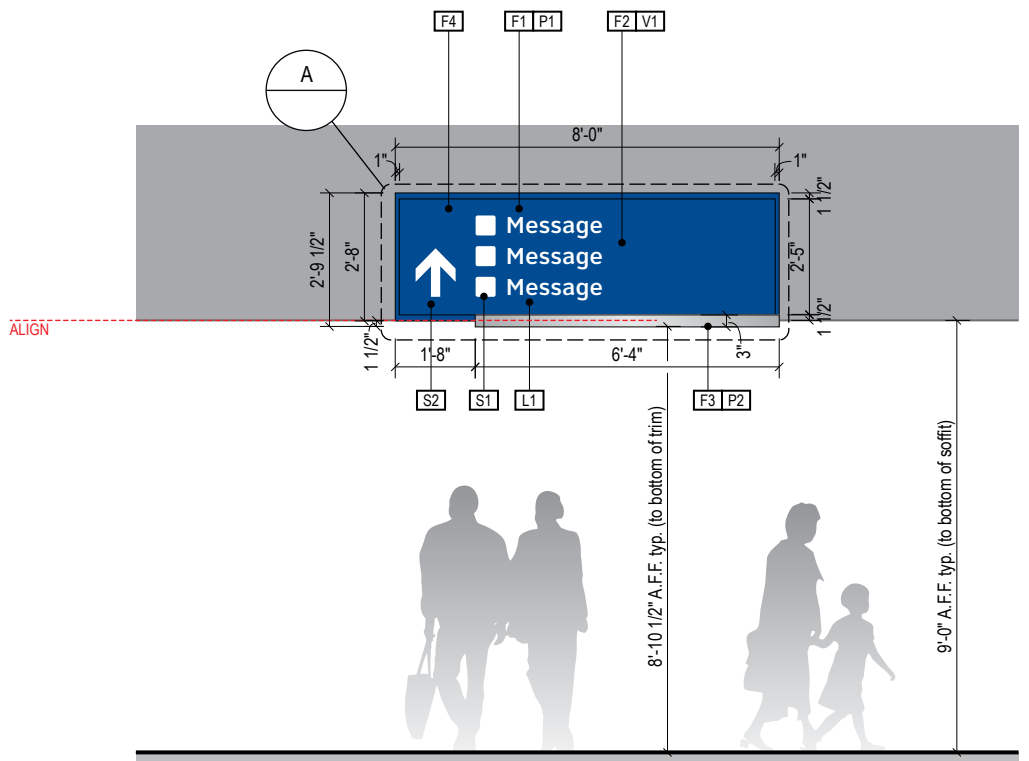

2 ELEVATION
Scale: 1/4" = 1'-0"

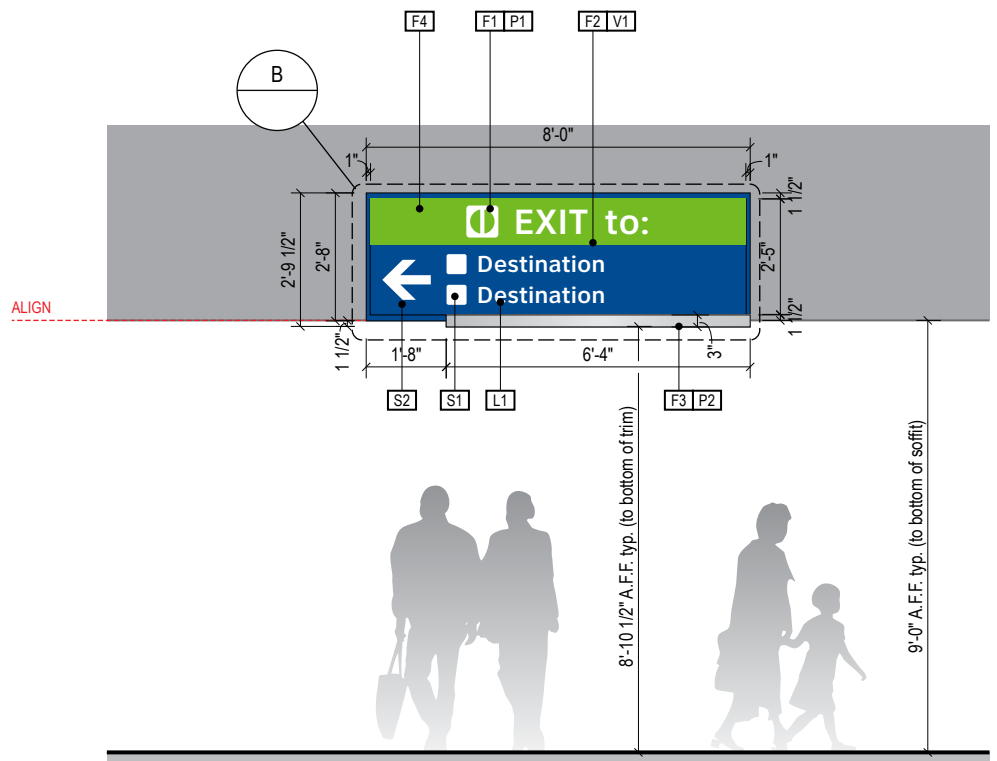

3 ELEVATION w/ ALTERNATE LAYOUT
Scale: 1/4" = 1'-0"

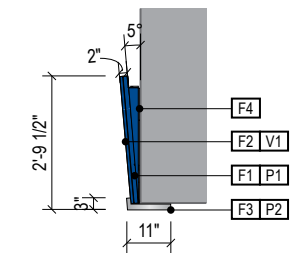

4 END VIEW
Scale: 1/4" = 1'-0"

ILLUMINATION	SIGN TYPE	SIGN FUNCTION	MOUNTING METHOD	GENERAL DESCRIPTION & USE
INTERNAL	1-DR.02 / 1-DR.05	DIRECTIONAL	SUSPENDED	Overhead Directional

GENERAL NOTES

- All final design, engineering, and amount/sizing of structural sign support elements, material types/thicknesses, dimensions, and attachment methods shall be performed and approved by a licensed engineer to meet or exceed all applicable local and national codes.
- Final engineering, dimensions, materials, and fabrication are the responsibility of the Fabricator to ensure the highest quality fit and finish for all components of the completed product. All final detailing and specifications to be provided by the Fabricator within their final approved fabrication-ready shop drawings.
- Wherever dissimilar metals are in contact, always separate contact surfaces prior to assembly or installation with the necessary protective coatings/gaskets/washers to prevent galvanic corrosion.
- Final fabrication methods, quality and fit/finish to be reviewed and approved by DFW Airport Planning Department and wayfinding/architecture Design Consultants thru prototype reviews prior to final production run/installation processes (see Performance Specifications for details).
- Colors shown are for reference only, and are subject to the limitations of the printing process and/or variance of electronic RGB screen displays. Refer to color system swatches and/or final finish samples for accurate reference.
- Messages shown here are general placeholders only. See graphic message schedules for specific messaging by location and sign type.

FABRICATION INTENT NOTES

- F1** SIGN CABINET/FRAME: modular fabricated internal illuminated edge-lit sign module cabinet constructed of extruded aluminum and cast aluminum components with concealed internal welds; removable sign face and light modules; fabricated aluminum support frame with welded mitered corners and slotted mounting holes to accept sign mounting brackets; fabricated alum. sign mounting frame with tapered side end cover panels, attached with aluminum pin and clip system; power feed/units hidden behind mounting frame with access holes in back for wall mounting; powdercoat all exposed surfaces of sign cabinet/support frame/mounting frame to match P1 satin finish
- F2** SIGN FACE: fabricated sign face assembly module constructed of extruded aluminum frame and concealed internal welds; faces are 3/16" white acrylic with 1st surface applied V1 vinyl film, graphics reversed out of blue (white is exposed white acrylic cut-thru blue film); faces illuminated with light panel assembly using LED edge-lit clear inscribed acrylic diffuser and self-contained technology (including electronics, extruded frame and diffuser)
- F3** TRIM: .080 fabricated alum. trim piece with closed ends; detachable and mounted with keyholes/studs and set screws; paint all exposed surfaces to match P2, satin finish
- F4** MOUNTING: mount to hidden above-ceiling structural elements with connection system as installation location conditions require (Fabricator to coordinate connection location/type of structural elements with General Contractor); 2" diameter aluminum suspension tube supports with 4" diameter 3/16" aluminum escutcheon cover plate at ceiling connection point, paint all exposed surfaces to match P2, satin finish; attached to sign support frame with weld applied flanges and mechanical fasteners

GRAPHICS / COLORS / DECORATION NOTES

- L1** Typeface: font = ClearviewText Medium
- S1** Universal Symbols: AIGA style symbol artwork
- S2** Arrow(s): use only official DFW Airport wayfinding arrow artwork
- VINYL (FILM):**
- V1** Blue: 3M EC 7725-37 Sapphire Blue
- V2** White: 3M 7725-20 Opaque Matte White
- V3** Skyink Yellow: 3M 7725-114 Enamel Receptive
- PAINT:**
- P1** Blue: Powder coated to match 3M EC 7725-37, satin finish
- P2** Silver: MAP paint # MP30136, satin finish

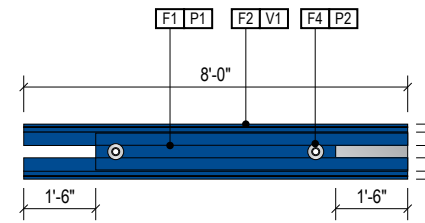

1 PLAN VIEW

Scale: 1/4" = 1'-0"

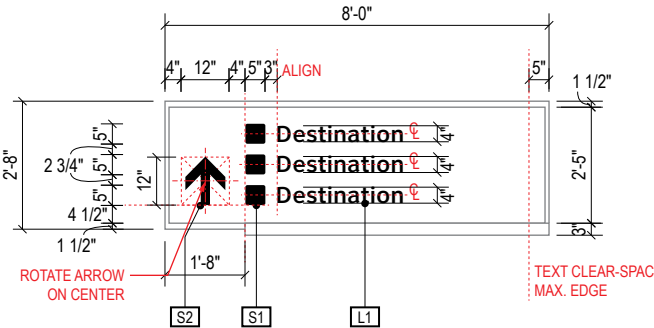

A DETAIL A: Face Layout

Scale: 1/4" = 1'-0"

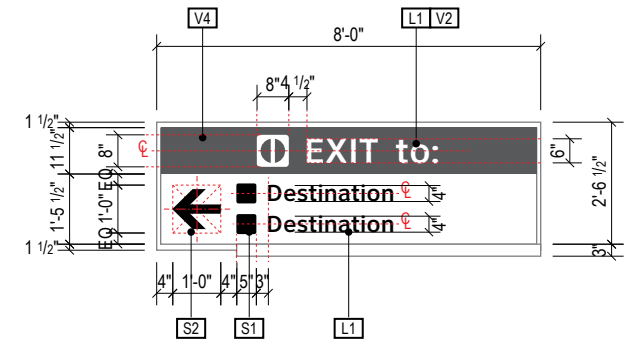

B DETAIL B: Alternate Face Layout

Scale: 1/4" = 1'-0"

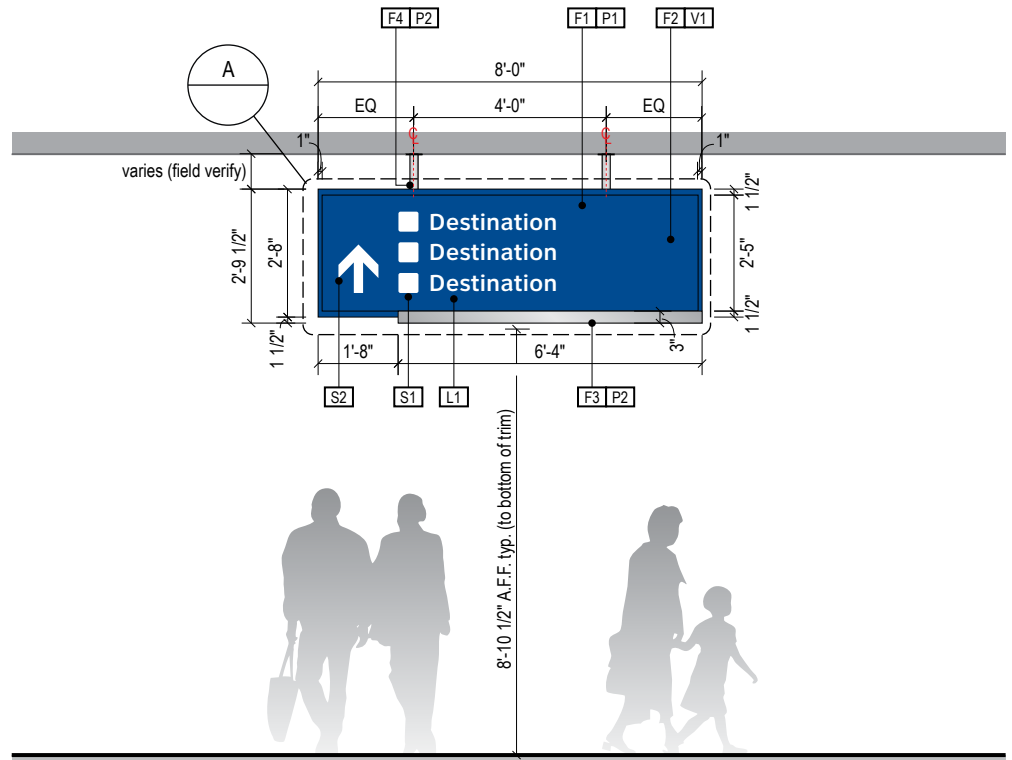

2 ELEVATION

Scale: 1/4" = 1'-0"

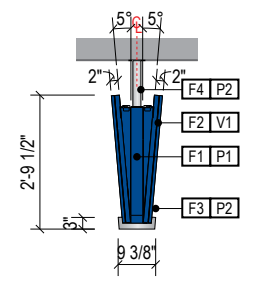

3 END VIEW

Scale: 1/4" = 1'-0"

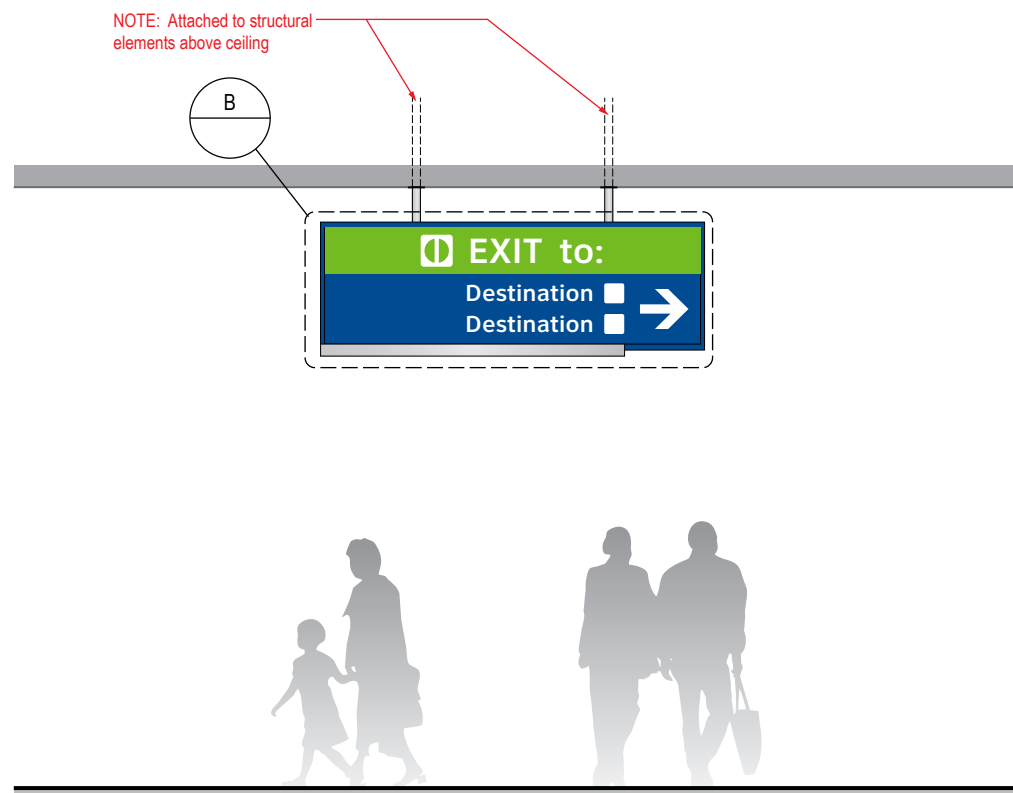

4 ELEVATION w/ ALTERNATE LAYOUT (OPPOSITE SIDE)

Scale: 1/4" = 1'-0"

ILLUMINATION	SIGN TYPE	SIGN FUNCTION	MOUNTING METHOD	GENERAL DESCRIPTION & USE
INTERNAL	1-DR.21	DIRECTIONAL	FASCIA MOUNT	Overhead Directional

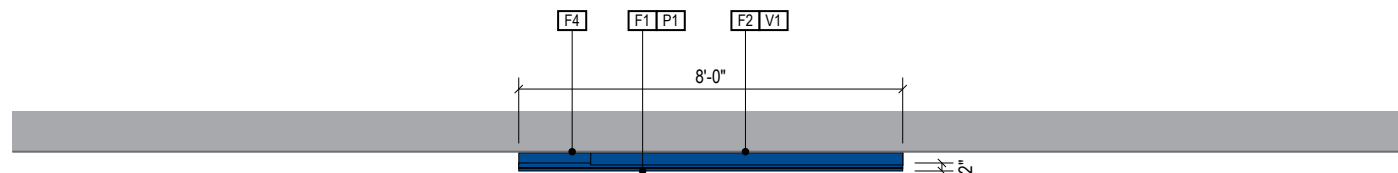

1 PLAN VIEW
Scale: 1/4" = 1'-0"

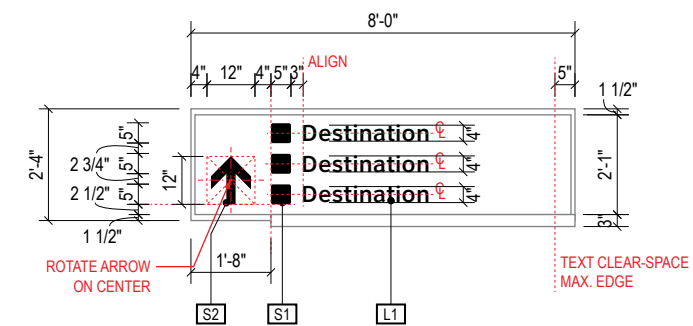

A DETAIL A: Face Layout
Scale: 1/4" = 1'-0"

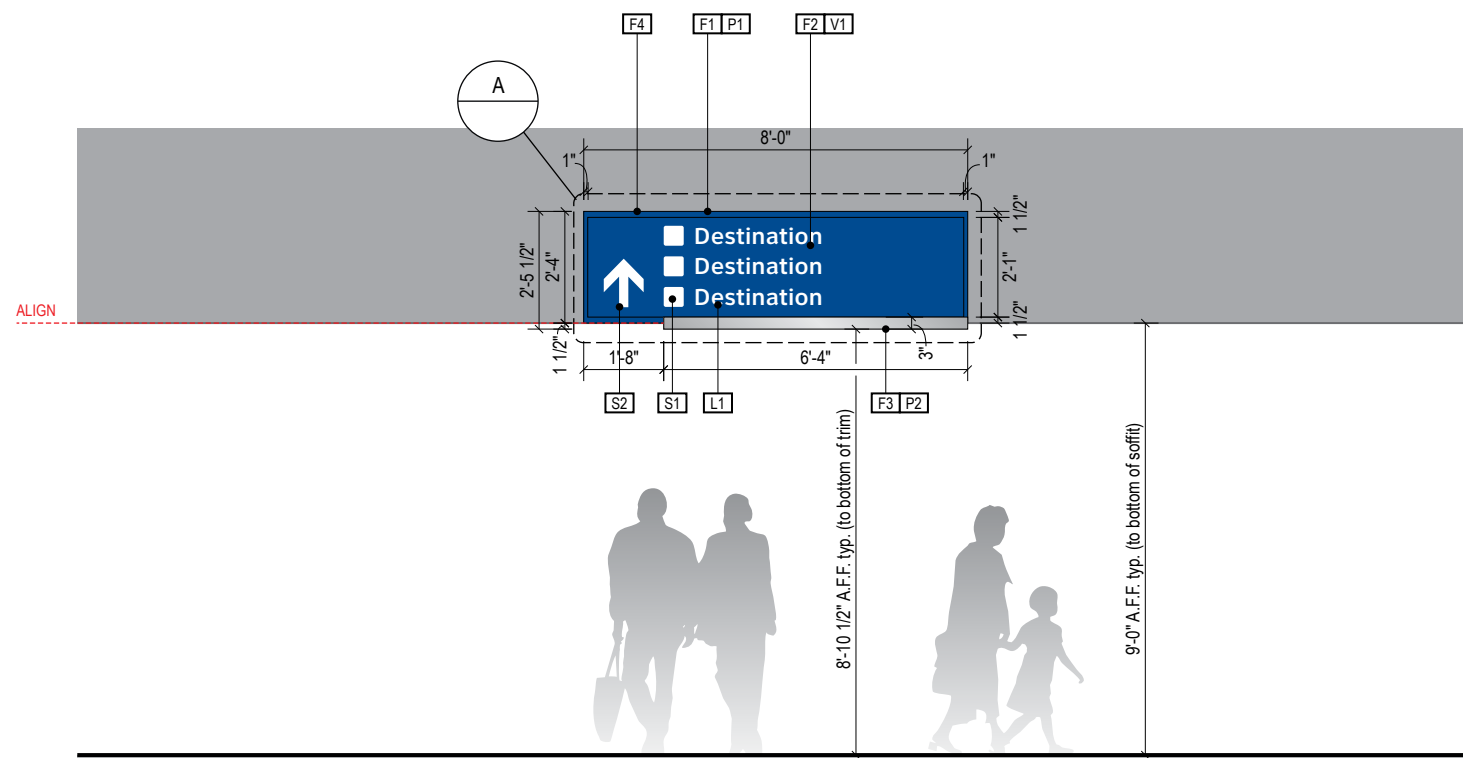

2 ELEVATION
Scale: 1/4" = 1'-0"

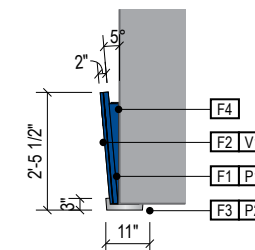

3 END VIEW
Scale: 1/4" = 1'-0"

GENERAL NOTES

- All final design, engineering, and amount/sizing of structural sign support elements, material types/thicknesses, dimensions, and attachment methods shall be performed and approved by a licensed engineer to meet or exceed all applicable local and national codes.
- Final engineering, dimensions, materials, and fabrication are the responsibility of the Fabricator to ensure the highest quality fit and finish for all components of the completed product. All final detailing and specifications to be provided by the Fabricator within their final approved fabrication-ready shop drawings.
- Wherever dissimilar metals are in contact, always separate contact surfaces prior to assembly or installation with the necessary protective coatings/gaskets/washers to prevent galvanic corrosion.
- Final fabrication methods, quality and fit/finish to be reviewed and approved by DFW Airport Planning Department and wayfinding/architecture Design Consultants thru prototype reviews prior to final production run/installation processes (see Performance Specifications for details).
- Colors shown are for reference only, and are subject to the limitations of the printing process and/or variance of electronic RGB screen displays. Refer to color system swatches and/or final finish samples for accurate reference.
- Messages shown here are general placeholders only. See graphic message schedules for specific messaging by location and sign type.

FABRICATION INTENT NOTES

- F1** SIGN CABINET/FRAME: modular fabricated internal illuminated edge-lit sign module cabinet constructed of extruded aluminum and cast aluminum components with concealed internal welds; removable sign face and light modules; fabricated aluminum support frame with welded mitered corners and slotted mounting holes to accept sign mounting brackets; fabricated alum. sign mounting frame with tapered side end cover panels, attached with aluminum pin and clip system; power feed/units hidden behind mounting frame with access holes in back for wall mounting; powdercoat all exposed surfaces of sign cabinet/support frame/mounting frame to match P1 satin finish
- F2** SIGN FACE: fabricated sign face assembly module constructed of extruded aluminum frame and concealed internal welds; faces are 3/16" white acrylic with 1st surface applied V1 vinyl film, graphics reversed out of blue (white is exposed white acrylic cut-thru blue film); faces illuminated with light panel assembly using LED edge-lit clear inscribed acrylic diffuser and self-contained technology (including electronics, extruded frame and diffuser)
- F3** TRIM: .080 fabricated alum. trim piece with closed ends; detachable and mounted with keyholes/studs and set screws; paint all exposed surfaces to match P2, satin finish
- F4** MOUNTING: mount to hidden above-ceiling structural elements with connection system as installation location conditions require (Fabricator to coordinate connection location/type of structural elements with General Contractor); 2" diameter aluminum suspension tube supports with 4" diameter 3/16" aluminum escutcheon cover plate at ceiling connection point, paint all exposed surfaces to match P2, satin finish; attached to sign support frame with weld applied flanges and mechanical fasteners

GRAPHICS / COLORS / DECORATION NOTES

- L1** Typeface: font = ClearviewText Medium
- S1** Universal Symbols: ALGA style symbol artwork
- S2** Arrow(s): use only official DFW Airport wayfinding arrow artwork
- VINYL (FILM):
- V1** Blue: 3M EC 7725-37 Sapphire Blue
- V2** White: 3M 7725-20 Opaque Matte White
- V3** Skylink Yellow: 3M 7725-114 Enamel Receptive
- PAINT:
- P1** Blue: Powder coated to match 3M EC 7725-37, satin finish
- P2** Silver: MAP paint # MP30136, satin finish

WARNING:

This record contains Sensitive Security Information that is controlled under 49 CFR parts 15 and 1520. No part of this record may be disclosed to persons with a "need to know," as defined in 49 CFR parts 15 and 1520, except with the written permission of the Administrator of the Transportation Security Administration or the Secretary of Transportation. Unauthorized release may result in civil penalty or other action. For U.S. government agencies, public disclosure is governed by 5 U.S.C. 552 and 49 CFR parts 15 and 1520.

ILLUMINATION	SIGN TYPE	SIGN FUNCTION	MOUNTING METHOD	GENERAL DESCRIPTION & USE
INTERNAL	1-DR.03	DIRECTIONAL	SUSPENDED	Overhead Directional

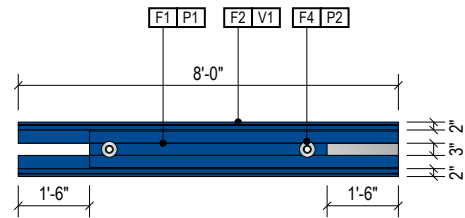

1 PLAN VIEW
Scale: 1/4" = 1'-0"

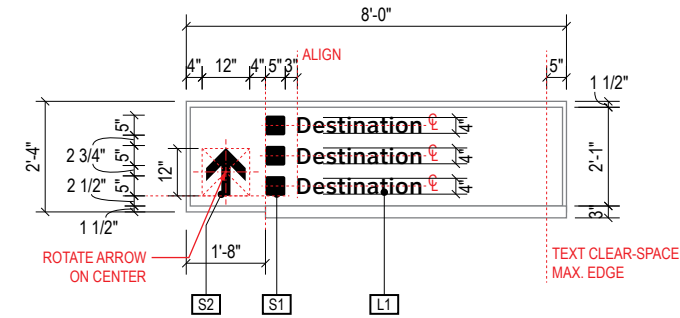

A DETAIL A: Face Layout
Scale: 1/4" = 1'-0"

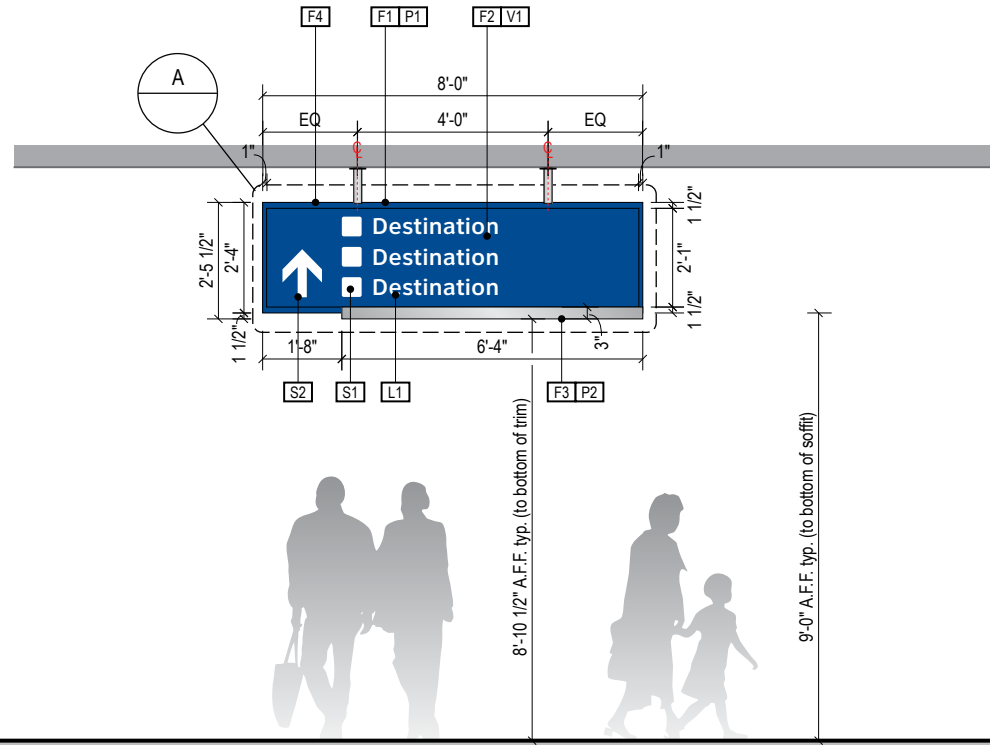

2 ELEVATION
Scale: 1/4" = 1'-0"

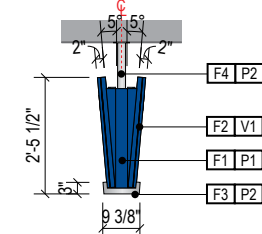

3 END VIEW
Scale: 1/4" = 1'-0"

GENERAL NOTES

- All final design, engineering, and amount/sizing of structural sign support elements, material types/thicknesses, dimensions, and attachment methods shall be performed and approved by a licensed engineer to meet or exceed all applicable local and national codes.
- Final engineering, dimensions, materials, and fabrication are the responsibility of the Fabricator to ensure the highest quality fit and finish for all components of the completed product. All final detailing and specifications to be provided by the Fabricator within their final approved fabrication-ready shop drawings.
- Wherever dissimilar metals are in contact, always separate contact surfaces prior to assembly or installation with the necessary protective coatings/gaskets/washers to prevent galvanic corrosion.
- Final fabrication methods, quality and fit/finish to be reviewed and approved by DFW Airport Planning Department and wayfinding/architecture Design Consultants thru prototype reviews prior to final production run/installation processes (see Performance Specifications for details).
- Colors shown are for reference only, and are subject to the limitations of the printing process and/or variance of electronic RGB screen displays. Refer to color system swatches and/or final finish samples for accurate reference.
- Messages shown here are general placeholders only. See graphic message schedules for specific messaging by location and sign type.

FABRICATION INTENT NOTES

- F1** SIGN CABINET/FRAME: modular fabricated internal illuminated edge-lit sign module cabinet constructed of extruded aluminum and cast aluminum components with concealed internal welds; removable sign face and light modules; fabricated aluminum support frame with welded mitered corners and slotted mounting holes to accept sign mounting brackets; fabricated alum. sign mounting frame with tapered side end cover panels, attached with aluminum pin and clip system; power feed/units hidden behind mounting frame with access holes in back for wall mounting; powdercoat all exposed surfaces of sign cabinet/support frame/mounting frame to match P1 satin finish
- F2** SIGN FACE: fabricated sign face assembly module constructed of extruded aluminum frame and concealed internal welds; faces are 3/16" white acrylic with 1st surface applied V1 vinyl film, graphics reversed out of blue (white is exposed white acrylic cut-thru blue film); faces illuminated with light panel assembly using LED edge-lit clear inscribed acrylic diffuser and self-contained technology (including electronics, extruded frame and diffuser)
- F3** TRIM: .080 fabricated alum. trim piece with closed ends; detachable and mounted with keyholes/studs and set screws; paint all exposed surfaces to match P2, satin finish
- F4** MOUNTING: mount to hidden above-ceiling structural elements with connection system as installation location conditions require (Fabricator to coordinate connection location/type of structural elements with General Contractor); 2" diameter aluminum suspension tube supports with 4" diameter 3/16" aluminum escutcheon cover plate at ceiling connection point, paint all exposed surfaces to match P2, satin finish; attached to sign support frame with weld applied flanges and mechanical fasteners

GRAPHICS / COLORS / DECORATION NOTES

- L1** Typeface: font = ClearviewText Medium
- S1** Universal Symbols: AIGA style symbol artwork
- S2** Arrow(s): use only official DFW Airport wayfinding arrow artwork
- VINYL (FILM):**
- V1** Blue: 3M EC 7725-37 Sapphire Blue
- V2** White: 3M 7725-20 Opaque Matte White
- V3** Skylink Yellow: 3M 7725-114 Enamel Receptive
- PAINT:**
- P1** Blue: Powder coated to match 3M EC 7725-37, satin finish
- P2** Silver: MAP paint # MP30136, satin finish

WARNING:

This record contains Sensitive Security Information that is controlled under 49 CFR parts 15 and 1520. No part of this record may be disclosed to persons with a "need to know," as defined in 49 CFR parts 15 and 1520, except with the written permission of the Administrator of the Transportation Security Administration or the Secretary of Transportation. Unauthorized release may result in civil penalty or other action. For U.S. government agencies, public disclosure is governed by 5 U.S.C. 552 and 49 CFR parts 15 and 1520.

ILLUMINATION	SIGN TYPE	SIGN FUNCTION	MOUNTING METHOD	GENERAL DESCRIPTION & USE
INTERNAL	1-DR.01	DIRECTIONAL	FASCIA MOUNT	Overhead Directional

GENERAL NOTES

- All final design, engineering, and amount/sizing of structural sign support elements, material types/thicknesses, dimensions, and attachment methods shall be performed and approved by a licensed engineer to meet or exceed all applicable local and national codes.
- Final engineering, dimensions, materials, and fabrication are the responsibility of the Fabricator to ensure the highest quality fit and finish for all components of the completed product. All final detailing and specifications to be provided by the Fabricator within their final approved fabrication-ready shop drawings.
- Wherever dissimilar metals are in contact, always separate contact surfaces prior to assembly or installation with the necessary protective coatings/gaskets/washers to prevent galvanic corrosion.
- Final fabrication methods, quality and fit/finish to be reviewed and approved by DFW Airport Planning Department and wayfinding/architecture Design Consultants thru prototype reviews prior to final production run/installation processes (see Performance Specifications for details).
- Colors shown are for reference only, and are subject to the limitations of the printing process and/or variance of electronic RGB screen displays. Refer to color system swatches and/or final finish samples for accurate reference.
- Messages shown here are general placeholders only. See graphic message schedules for specific messaging by location and sign type.

FABRICATION INTENT NOTES

- F1** SIGN CABINET/FRAME: modular fabricated internal illuminated edge-lit sign module cabinet constructed of extruded aluminum and cast aluminum components with concealed internal welds; removable sign face and light modules; fabricated aluminum support frame with welded mitered corners and slotted mounting holes to accept sign mounting brackets; fabricated aluminum sign mounting frame with tapered side end cover panels, attached with aluminum pin and clip system; power feed/units hidden behind mounting frame with access holes in back for wall mounting; powdercoat all exposed surfaces of sign cabinet/support frame/mounting frame to match P1, satin finish
- F2** SIGN FACE: fabricated sign face assembly module constructed of extruded aluminum frame and concealed internal welds; faces are 3/16" white acrylic with 1st surface applied V1 vinyl film, graphics reversed out of blue (white is exposed white acrylic cut-thru blue film); faces illuminated with light panel assembly using LED edge-lit clear inscribed acrylic diffuser and self-contained technology (including electronics, extruded frame and diffuser)
- F3** TRIM: .080 fabricated aluminum trim piece with closed ends; detachable and mounted with keyholes/studs and set screws; paint all exposed surfaces to match P2, satin finish
- F4** MOUNTING: mount to wall structural elements with connection system as installation location conditions require (Fabricator to coordinate connection location/type of structural elements with General Contractor); paint all exposed surfaces to match P1, satin finish

GRAPHICS / COLORS / DECORATION NOTES

- L1** Typeface: font = ClearviewText Medium
 - S1** Universal Symbols: AIGA style symbol artwork
 - S2** Arrow(s): use only official DFW wayfinding arrow artwork
- VINYL (FILM):
- V1** Blue: 3M EC 7725-37 Sapphire Blue
 - V2** White: 3M 7725-20 Opaque Matte White
 - V3** Skylink Yellow: 3M 7725-114 Enamel Receptive
 - V4** Exit Light Green: 3M Opaque Matte to match PMS 368C
- PAINT:
- P1** Blue: Powder coated to match 3M EC 7725-37, satin finish
 - P2** Silver: MAP paint # MP30136, satin finish

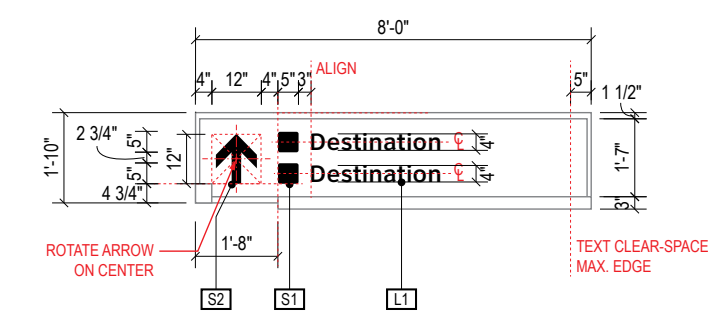

A DETAIL A: Face Layout
Scale: 1/4" = 1'-0"

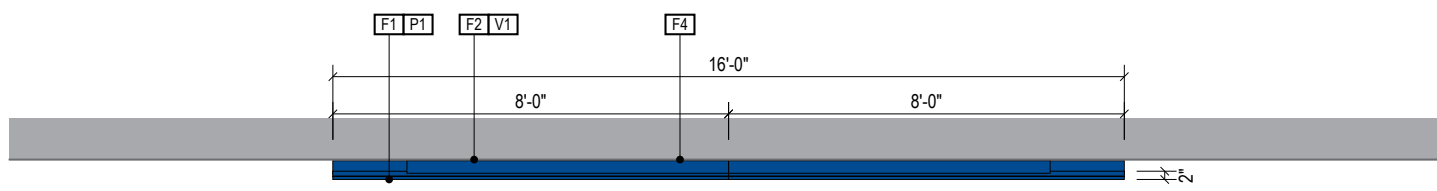

1 PLAN VIEW
Scale: 1/4" = 1'-0"

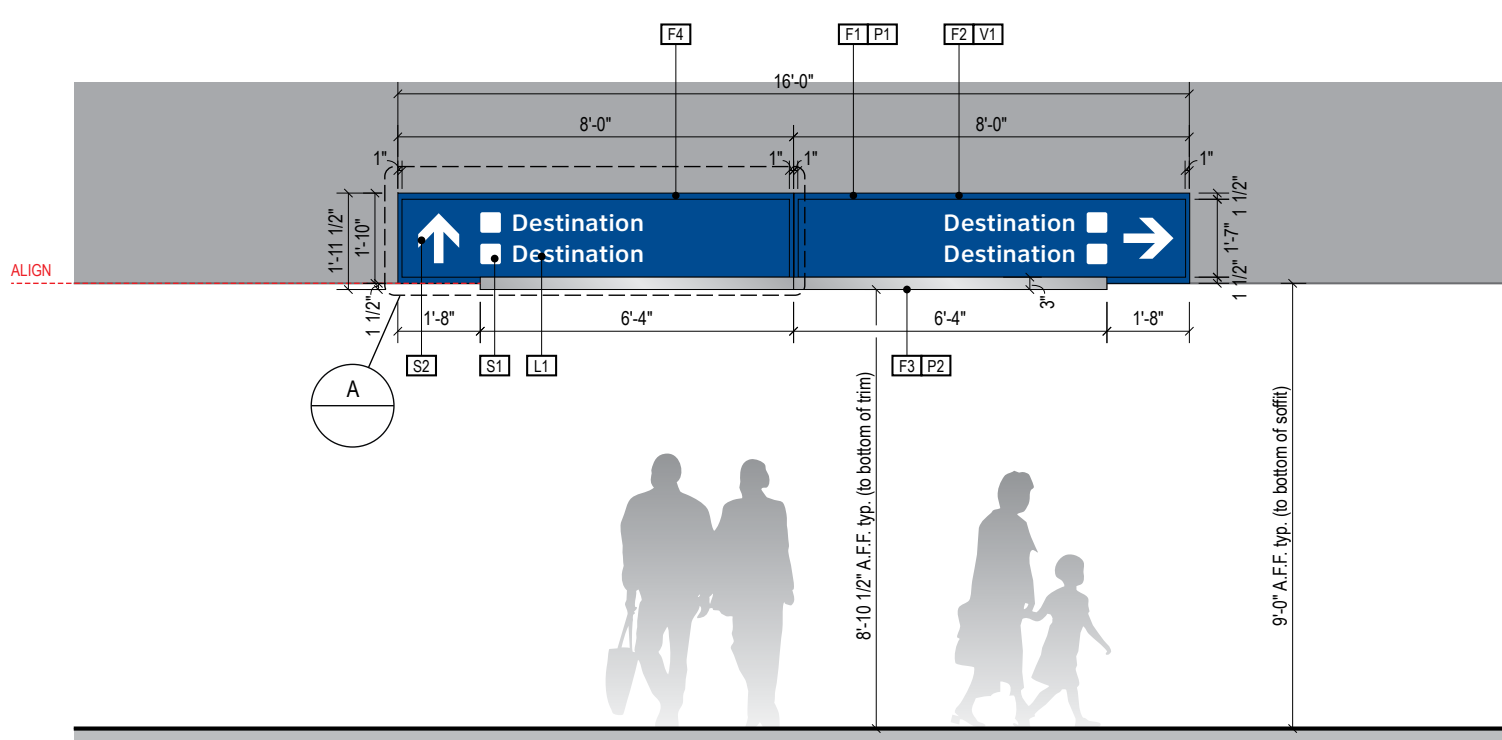

2 ELEVATION
Scale: 1/4" = 1'-0"

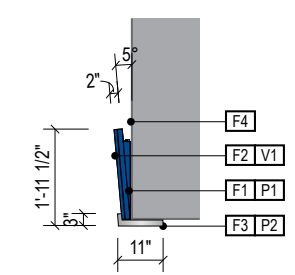

3 END VIEW
Scale: 1/4" = 1'-0"

ILLUMINATION	SIGN TYPE	SIGN FUNCTION	MOUNTING METHOD	GENERAL DESCRIPTION & USE
INTERNAL	1-DR.23	DIRECTIONAL	SUSPENDED	Overhead Directional

GENERAL NOTES

- All final design, engineering, and amount/sizing of structural sign support elements, material types/thicknesses, dimensions, and attachment methods shall be performed and approved by a licensed engineer to meet or exceed all applicable local and national codes.
- Final engineering, dimensions, materials, and fabrication are the responsibility of the Fabricator to ensure the highest quality fit and finish for all components of the completed product. All final detailing and specifications to be provided by the Fabricator within their final approved fabrication-ready shop drawings.
- Wherever dissimilar metals are in contact, always separate contact surfaces prior to assembly or installation with the necessary protective coatings/gaskets/washers to prevent galvanic corrosion.
- Final fabrication methods, quality and fit/finish to be reviewed and approved by DFW Airport Planning Department and wayfinding/architecture Design Consultants thru prototype reviews prior to final production run/installation processes (see Performance Specifications for details).
- Colors shown are for reference only, and are subject to the limitations of the printing process and/or variance of electronic RGB screen displays. Refer to color system swatches and/or final finish samples for accurate reference.
- Messages shown here are general placeholders only. See graphic message schedules for specific messaging by location and sign type.

FABRICATION INTENT NOTES

- F1** SIGN CABINET/FRAME: modular fabricated internal illuminated edge-lit sign module cabinet constructed of extruded aluminum and cast aluminum components with concealed internal welds; removable sign face and light modules; fabricated aluminum support frame with welded mitered corners and slotted mounting holes to accept sign mounting brackets; fabricated alum. sign mounting frame with tapered side end cover panels, attached with aluminum pin and clip system; power feed/units hidden behind mounting frame with access holes in back for wall mounting; powdercoat all exposed surfaces of sign cabinet/support frame/mounting frame to match P1 satin finish
- F2** SIGN FACE: fabricated sign face assembly module constructed of extruded aluminum frame and concealed internal welds; faces are 3/16" white acrylic with 1st surface applied V1 vinyl film, graphics reversed out of blue (white is exposed white acrylic cut-thru blue film); faces illuminated with light panel assembly using LED edge-lit clear inscribed acrylic diffuser and self-contained technology (including electronics, extruded frame and diffuser)
- F3** TRIM: .080 fabricated alum. trim piece with closed ends; detachable and mounted with keyholes/studs and set screws; paint all exposed surfaces to match P2, satin finish
- F4** MOUNTING: mount to hidden above-ceiling structural elements with connection system as installation location conditions require (Fabricator to coordinate connection location/type of structural elements with General Contractor); 2" diameter aluminum suspension tube supports with 4" diameter 3/16" aluminum escutcheon cover plate at ceiling connection point, paint all exposed surfaces to match P2, satin finish; attached to sign support frame with weld applied flanges and mechanical fasteners

GRAPHICS / COLORS / DECORATION NOTES

- L1** Typeface: font = ClearviewText Medium
- S1** Universal Symbols: AIGA style symbol artwork
- S2** Arrow(s): use only official DFW wayfinding arrow artwork
- VINYL (FILM):
- V1** Blue: 3M EC 7725-37 Sapphire Blue
- V2** White: 3M 7725-20 Opaque Matte White
- V3** Skylink Yellow: 3M 7725-114 Enamel Receptive
- PAINT:
- P1** Blue: Powder coated to match 3M EC 7725-37, satin finish
- P2** Silver: MAP paint # MP30136, satin finish

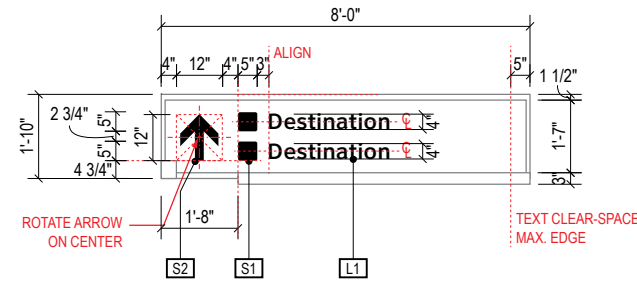

A DETAIL A: Face Layout
Scale: 1/4" = 1'-0"

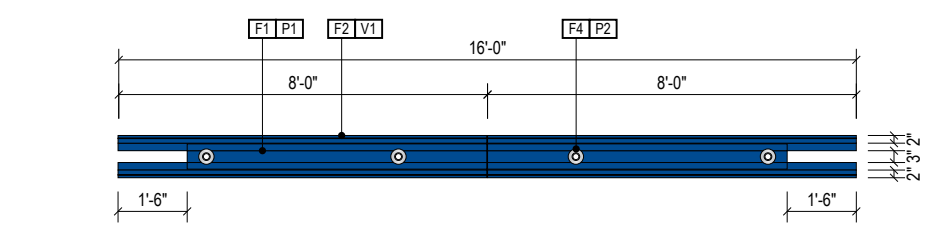

1 PLAN VIEW
Scale: 1/4" = 1'-0"

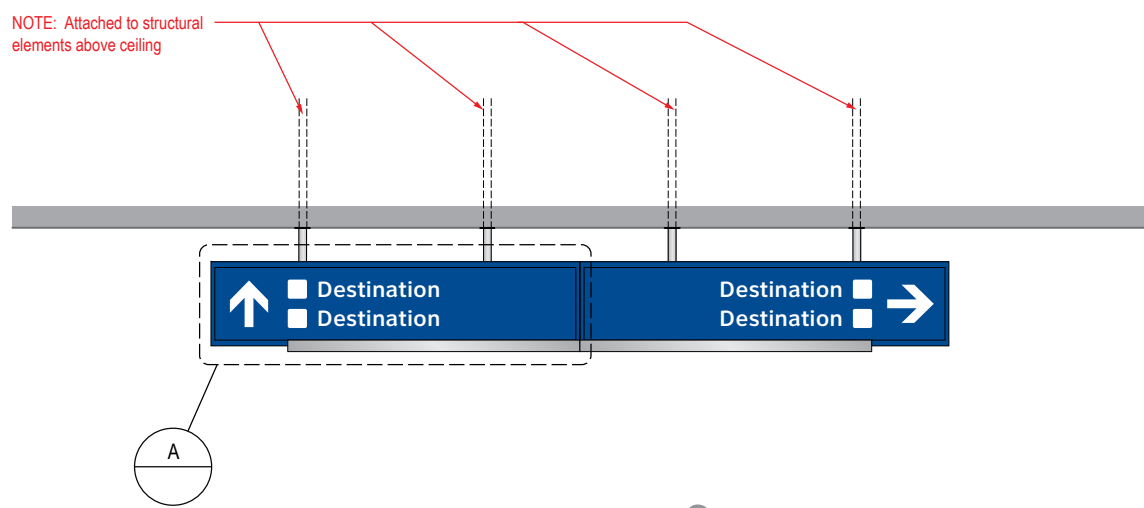

4 ELEVATION (OPPOSITE SIDE)
Scale: 1/4" = 1'-0"

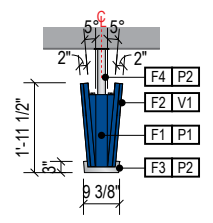

3 END VIEW
Scale: 1/4" = 1'-0"

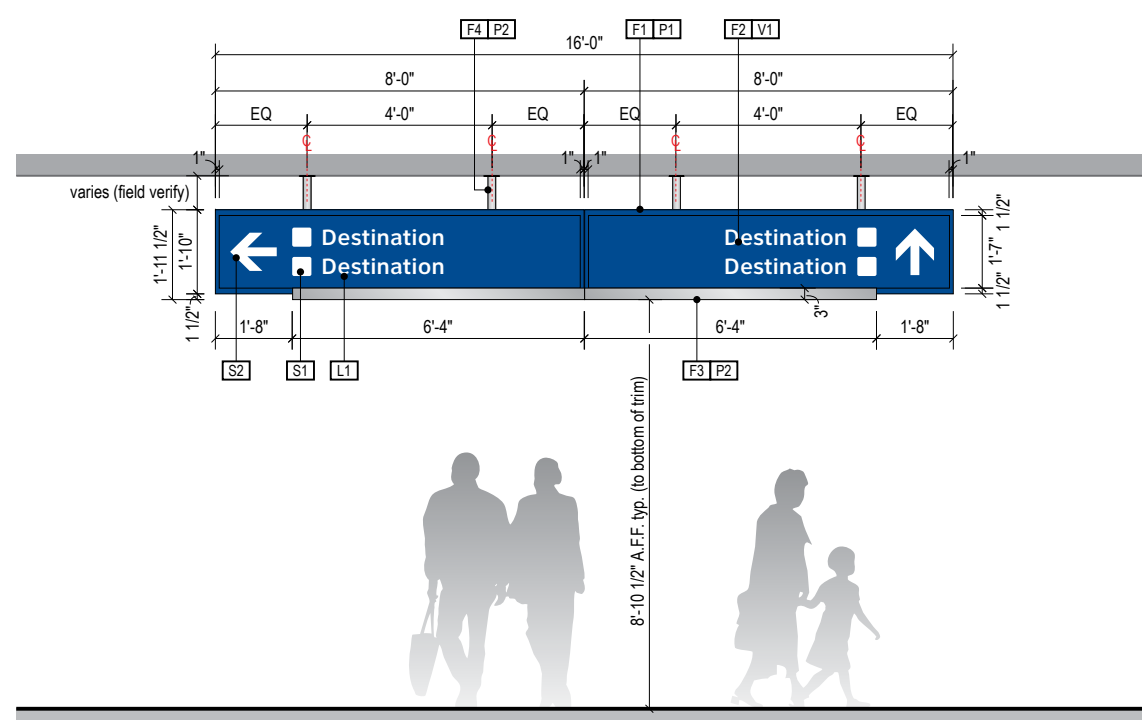

2 ELEVATION
Scale: 1/4" = 1'-0"

ILLUMINATION	SIGN TYPE	SIGN FUNCTION	MOUNTING METHOD	GENERAL DESCRIPTION & USE
INTERNAL	1-DR.22	DIRECTIONAL	FASCIA MOUNT	Overhead Directional

GENERAL NOTES

- All final design, engineering, and amount/sizing of structural sign support elements, material types/thicknesses, dimensions, and attachment methods shall be performed and approved by a licensed engineer to meet or exceed all applicable local and national codes.
- Final engineering, dimensions, materials, and fabrication are the responsibility of the Fabricator to ensure the highest quality fit and finish for all components of the completed product. All final detailing and specifications to be provided by the Fabricator within their final approved fabrication-ready shop drawings.
- Wherever dissimilar metals are in contact, always separate contact surfaces prior to assembly or installation with the necessary protective coatings/gaskets/washers to prevent galvanic corrosion.
- Final fabrication methods, quality and fit/finish to be reviewed and approved by DFW Airport Planning Department and wayfinding/architecture Design Consultants thru prototype reviews prior to final production run/installation processes (see Performance Specifications for details).
- Colors shown are for reference only, and are subject to the limitations of the printing process and/or variance of electronic RGB screen displays. Refer to color system swatches and/or final finish samples for accurate reference.
- Messages shown here are general placeholders only. See graphic message schedules for specific messaging by location and sign type.

FABRICATION INTENT NOTES

- F1** SIGN CABINET/FRAME: modular fabricated internal illuminated edge-lit sign module cabinet constructed of extruded aluminum and cast aluminum components with concealed internal welds; removable sign face and light modules; fabricated aluminum support frame with welded mitered corners and slotted mounting holes to accept sign mounting brackets; fabricated aluminum sign mounting frame with tapered side end cover panels, attached with aluminum pin and clip system; power feed/units hidden behind mounting frame with access holes in back for wall mounting; powdercoat all exposed surfaces of sign cabinet/support frame/mounting frame to match P1, satin finish
- F2** SIGN FACE: fabricated sign face assembly module constructed of extruded aluminum frame and concealed internal welds; faces are 3/16" white acrylic with 1st surface applied V1 vinyl film, graphics reversed out of blue (white is exposed white acrylic cut-thru blue film); faces illuminated with light panel assembly using LED edge-lit clear inscribed acrylic diffuser and self-contained technology (including electronics, extruded frame and diffuser)
- F3** TRIM: .080 fabricated aluminum trim piece with closed ends, detachable and mounted with keyholes/studs and set screws; paint all exposed surfaces to match P2, satin finish
- F4** MOUNTING: mount to wall structural elements with connection system as installation location conditions require (Fabricator to coordinate connection location/type of structural elements with General Contractor); paint all exposed surfaces to match P1, satin finish

GRAPHICS / COLORS / DECORATION NOTES

- L1** Typeface: font = ClearviewText Medium
 - S1** Universal Symbols: AIGA style symbol artwork
 - S2** Arrow(s): use only official DFW Airport wayfinding arrow artwork
 - V1** VINYL (FILM): Blue: 3M EC 7725-37 Sapphire Blue
 - V2** White: 3M 7725-20 Opaque Matte White
 - V3** Skylink Yellow: 3M 7725-114 Enamel Receptive
- PAINT:
- P1** Blue: Powder coated to match 3M EC 7725-37, satin finish
 - P2** Silver: MAP paint # MP30136, satin finish

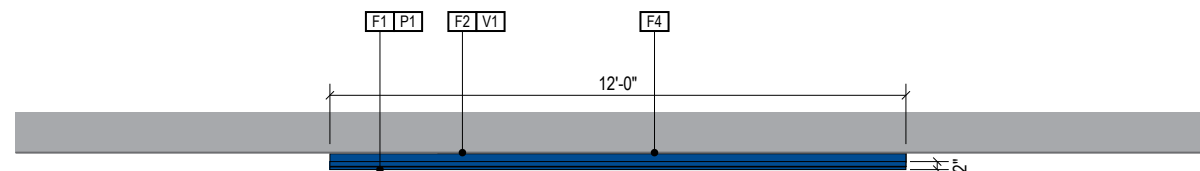

1 PLAN VIEW

Scale: 1/4" = 1'-0"

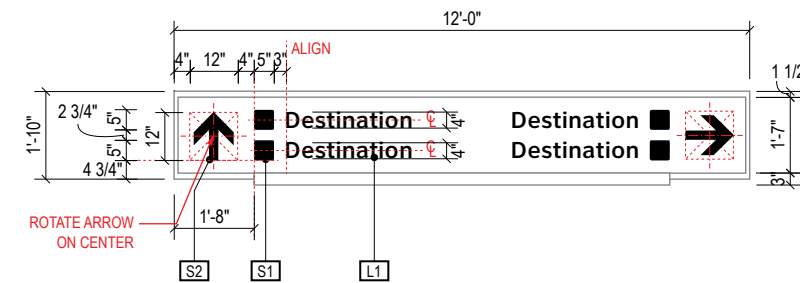

A DETAIL A: Face Layout

Scale: 1/4" = 1'-0"

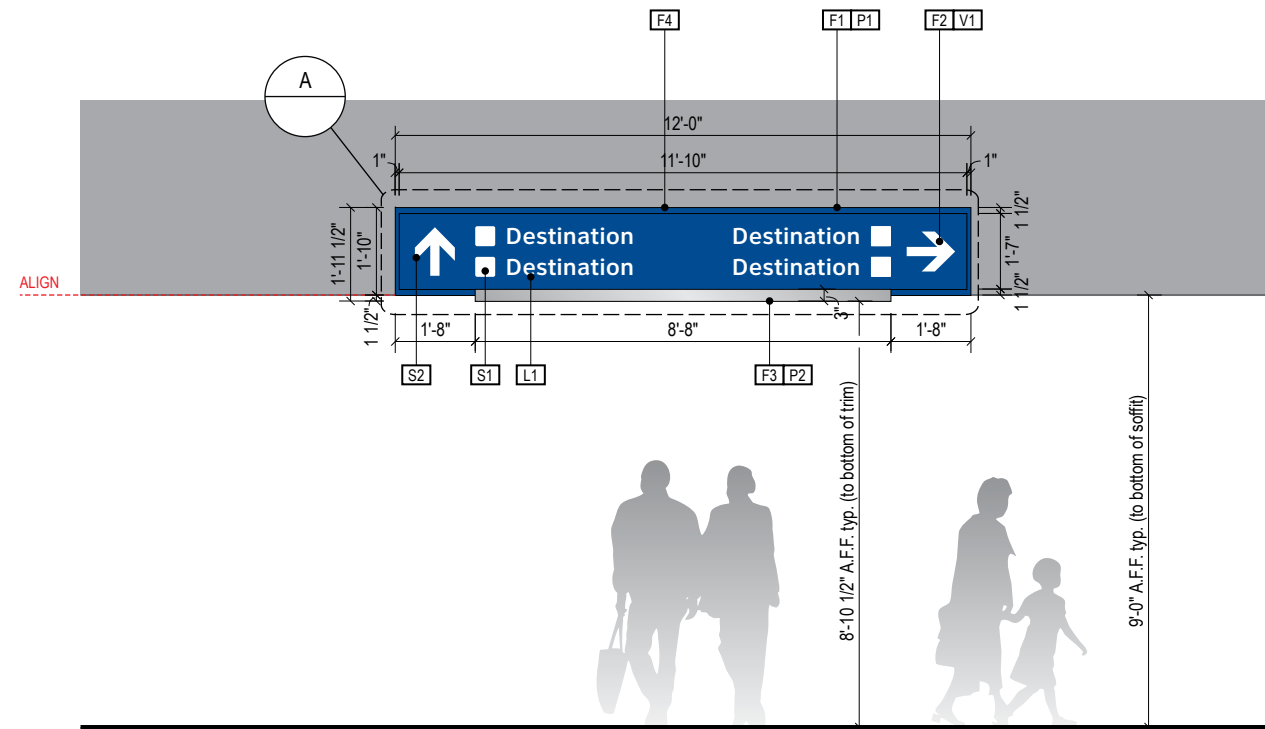

2 ELEVATION

Scale: 1/4" = 1'-0"

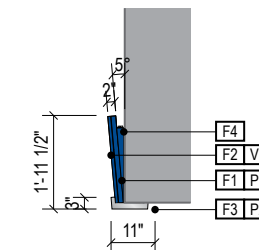

3 END VIEW

Scale: 1/4" = 1'-0"

WARNING:

This record contains Sensitive Security Information that is controlled under 49 CFR parts 15 and 1520. No part of this record may be disclosed to persons with a "need to know," as defined in 49 CFR parts 15 and 1520, except with the written permission of the Administrator of the Transportation Security Administration or the Secretary of Transportation. Unauthorized release may result in civil penalty or other action. For U.S. government agencies, public disclosure is governed by 5 U.S.C. 552 and 49 CFR parts 15 and 1520.

ILLUMINATION	SIGN TYPE	SIGN FUNCTION	MOUNTING METHOD	GENERAL DESCRIPTION & USE
INTERNAL	1-DR.04	DIRECTIONAL	SUSPENDED	Overhead Directional

GENERAL NOTES

- All final design, engineering, and amount/sizing of structural sign support elements, material types/thicknesses, dimensions, and attachment methods shall be performed and approved by a licensed engineer to meet or exceed all applicable local and national codes.
- Final engineering, dimensions, materials, and fabrication are the responsibility of the Fabricator to ensure the highest quality fit and finish for all components of the completed product. All final detailing and specifications to be provided by the Fabricator within their final approved fabrication-ready shop drawings.
- Wherever dissimilar metals are in contact, always separate contact surfaces prior to assembly or installation with the necessary protective coatings/gaskets/washers to prevent galvanic corrosion.
- Final fabrication methods, quality and fit/finish to be reviewed and approved by DFW Airport Planning Department and wayfinding/architecture Design Consultants thru prototype reviews prior to final production run/installation processes (see Performance Specifications for details).
- Colors shown are for reference only, and are subject to the limitations of the printing process and/or variance of electronic RGB screen displays. Refer to color system swatches and/or final finish samples for accurate reference.
- Messages shown here are general placeholders only. See graphic message schedules for specific messaging by location and sign type.

FABRICATION INTENT NOTES

- F1** SIGN CABINET/FRAME: modular fabricated internal illuminated edge-lit sign module cabinet constructed of extruded aluminum and cast aluminum components with concealed internal welds; removable sign face and light modules; fabricated aluminum support frame with welded mitered corners and slotted mounting holes to accept sign mounting brackets; fabricated alum. sign mounting frame with tapered side end cover panels, attached with aluminum pin and clip system; power feed/units hidden behind mounting frame with access holes in back for wall mounting; powdercoat all exposed surfaces of sign cabinet/support frame/mounting frame to match P1 satin finish
- F2** SIGN FACE: fabricated sign face assembly module constructed of extruded aluminum frame and concealed internal welds; faces are 3/16" white acrylic with 1st surface applied V1 vinyl film, graphics reversed out of blue (white is exposed white acrylic cut-thru blue film); faces illuminated with light panel assembly using LED edge-lit clear inscribed acrylic diffuser and self-contained technology (including electronics, extruded frame and diffuser)
- F3** TRIM: .080 fabricated alum. trim piece with closed ends; detachable and mounted with keyholes/studs and set screws; paint all exposed surfaces to match P2, satin finish
- F4** MOUNTING: mount to hidden above-ceiling structural elements with connection system as installation location conditions require (Fabricator to coordinate connection location/type of structural elements with General Contractor); 2" diameter aluminum suspension tube supports with 4" diameter 3/16" aluminum escutcheon cover plate at ceiling connection point, paint all exposed surfaces to match P2, satin finish; attached to sign support frame with weld applied flanges and mechanical fasteners

GRAPHICS / COLORS / DECORATION NOTES

- L1** Typeface: font = ClearviewText Medium
 - S1** Universal Symbols: AIGA style symbol artwork
 - S2** Arrow(s): use only official DFW Airport wayfinding arrow artwork
 - VINYL (FILM):**
 - V1** Blue: 3M EC 7725-37 Sapphire Blue
 - V2** White: 3M 7725-20 Opaque Matte White
 - V3** Skylink Yellow: 3M 7725-114 Enamel Receptive
- PAINT:
- P1** Blue: Powder coated to match 3M EC 7725-37, satin finish
 - P2** Silver: MAP paint # MP30136, satin finish

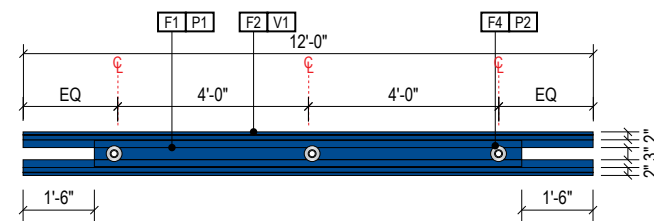

1 PLAN VIEW

Scale: 1/4" = 1'-0"

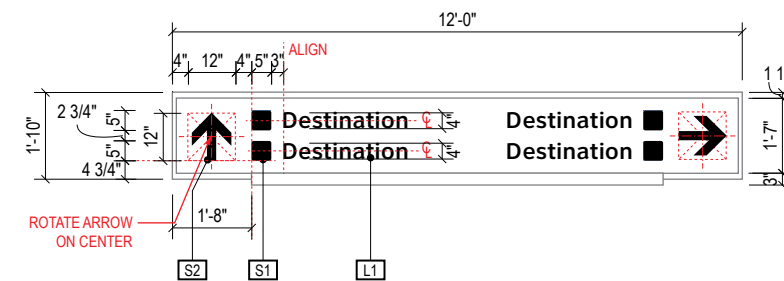

A DETAIL A: Face Layout

Scale: 1/4" = 1'-0"

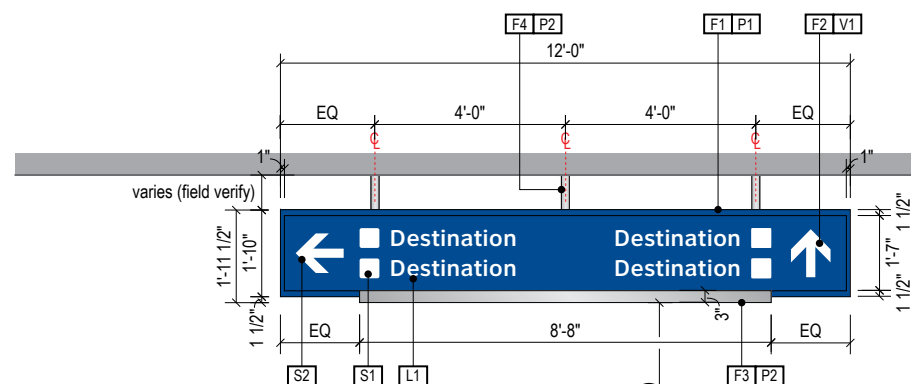

2 ELEVATION

Scale: 1/4" = 1'-0"

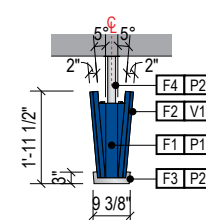

3 END VIEW

Scale: 1/4" = 1'-0"

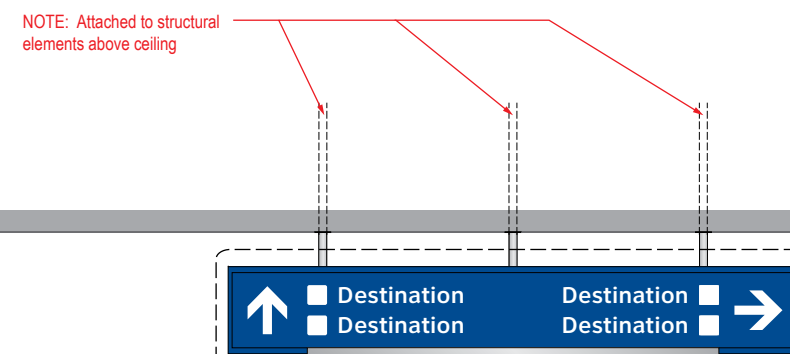

4 ELEVATION (OPPOSITE SIDE)

Scale: 1/4" = 1'-0"

WARNING:

This record contains Sensitive Security Information that is controlled under 49 CFR parts 15 and 1520. No part of this record may be disclosed to persons with a "need to know," as defined in 49 CFR parts 15 and 1520, except with the written permission of the Administrator of the Transportation Security Administration or the Secretary of Transportation. Unauthorized release may result in civil penalty or other action. For U.S. government agencies, public disclosure is governed by 5 U.S.C. 552 and 49 CFR parts 15 and 1520.

ILLUMINATION	SIGN TYPE	SIGN FUNCTION	MOUNTING METHOD	GENERAL DESCRIPTION & USE
INTERNAL	1-DR.24	DIRECTIONAL	FASCIA MOUNT	Overhead Directional

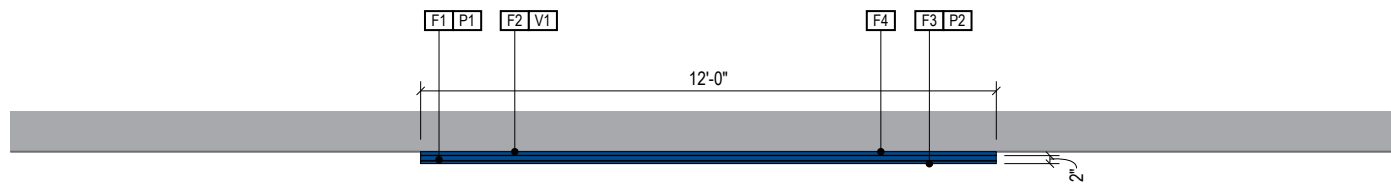

1 PLAN VIEW
Scale: 1/4" = 1'-0"

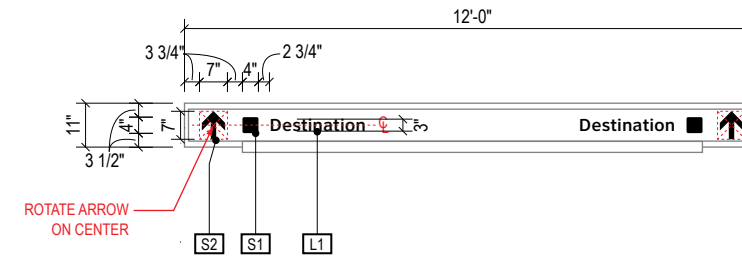

A DETAIL A: Face Layout
Scale: 1/4" = 1'-0"

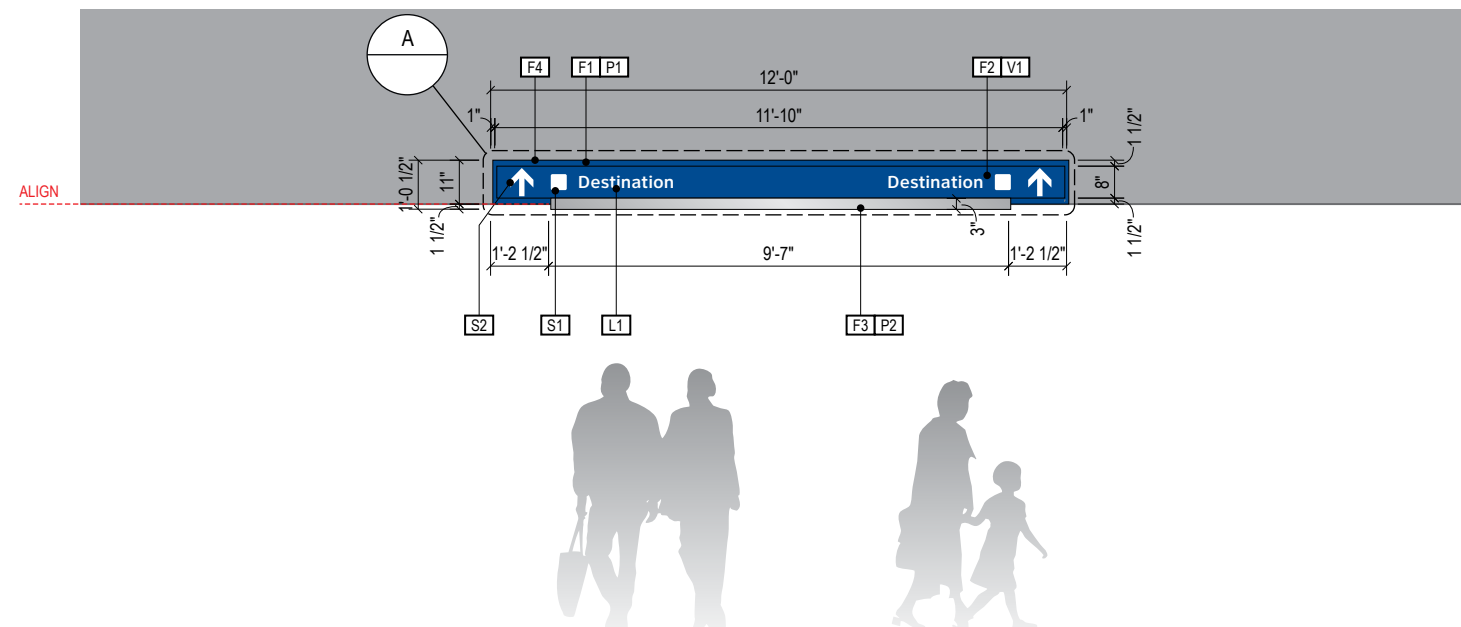

2 ELEVATION
Scale: 1/4" = 1'-0"

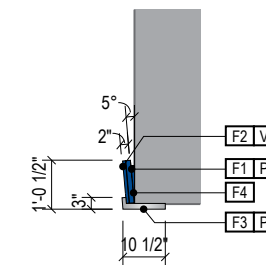

3 END VIEW
Scale: 1/4" = 1'-0"

GENERAL NOTES

- All final design, engineering, and amount/sizing of structural sign support elements, material types/thicknesses, dimensions, and attachment methods shall be performed and approved by a licensed engineer to meet or exceed all applicable local and national codes.
- Final engineering, dimensions, materials, and fabrication are the responsibility of the Fabricator to ensure the highest quality fit and finish for all components of the completed product. All final detailing and specifications to be provided by the Fabricator within their final approved fabrication-ready shop drawings.
- Wherever dissimilar metals are in contact, always separate contact surfaces prior to assembly or installation with the necessary protective coatings/gaskets/washers to prevent galvanic corrosion.
- Final fabrication methods, quality and fit/finish to be reviewed and approved by DFW Airport Planning Department and wayfinding/architecture Design Consultants thru prototype reviews prior to final production run/installation processes (see Performance Specifications for details).
- Colors shown are for reference only, and are subject to the limitations of the printing process and/or variance of electronic RGB screen displays. Refer to color system swatches and/or final finish samples for accurate reference.
- Messages shown here are general placeholders only. See graphic message schedules for specific messaging by location and sign type.

FABRICATION INTENT NOTES

- F1** SIGN CABINET/FRAME: modular fabricated internal illuminated edge-lit sign module cabinet constructed of extruded aluminum and cast aluminum components with concealed internal welds; removable sign face and light modules; fabricated aluminum support frame with welded mitered corners and slotted mounting holes to accept sign mounting brackets; fabricated aluminum sign mounting frame with tapered side end cover panels, attached with aluminum pin and clip system; power feed/units hidden behind mounting frame with access holes in back for wall mounting; powdercoat all exposed surfaces of sign cabinet/support frame/mounting frame to match P1, satin finish
- F2** SIGN FACE: fabricated sign face assembly module constructed of extruded aluminum frame and concealed internal welds; faces are 3/16" white acrylic with 1st surface applied V1 vinyl film, graphics reversed out of blue (white is exposed white acrylic cut-thru blue film); faces illuminated with light panel assembly using LED edge-lit clear inscribed acrylic diffuser and self-contained technology (including electronics, extruded frame and diffuser)
- F3** TRIM: .080 fabricated aluminum trim piece with closed ends; detachable and mounted with keyholes/studs and set screws; paint all exposed surfaces to match P2, satin finish
- F4** MOUNTING: mount to wall structural elements with connection system as installation location conditions require (Fabricator to coordinate connection location/type of structural elements with General Contractor); paint all exposed surfaces to match P1, satin finish

GRAPHICS / COLORS / DECORATION NOTES

- L1** Typeface: font = ClearviewText Medium
- S1** Universal Symbols: AIGA style symbol artwork
- S2** Arrow(s): use only official DFW wayfinding arrow artwork
- VINYL (FILM):
- V1** Blue: 3M EC 7725-37 Sapphire Blue
- V2** White: 3M 7725-20 Opaque Matte White
- V3** Skylink Yellow: 3M 7725-114 Enamel Receptive
- PAINT:
- P1** Blue: Powder coated to match 3M EC 7725-37, satin finish
- P2** Silver: MAP paint # MP30136, satin finish

WARNING:

This record contains Sensitive Security Information that is controlled under 49 CFR parts 15 and 1520. No part of this record may be disclosed to persons with a "need to know," as defined in 49 CFR parts 15 and 1520, except with the written permission of the Administrator of the Transportation Security Administration or the Secretary of Transportation. Unauthorized release may result in civil penalty or other action. For U.S. government agencies, public disclosure is governed by 5 U.S.C. 552 and 49 CFR parts 15 and 1520.

ILLUMINATION	SIGN TYPE	SIGN FUNCTION	MOUNTING METHOD	GENERAL DESCRIPTION & USE
INTERNAL	1-DR.26	DIRECTIONAL	FASCIA MOUNT	Exit Vestibule Directional - Fascia Mounted

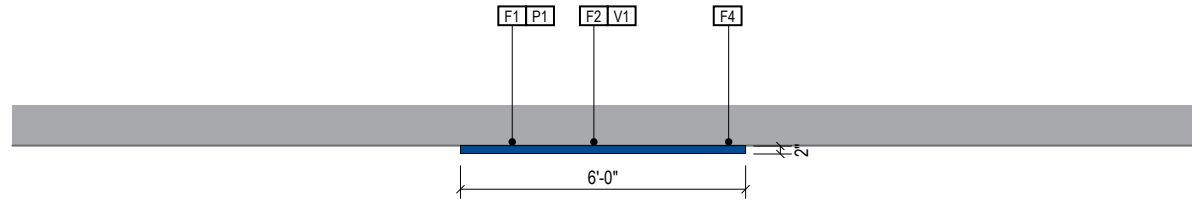

1 PLAN VIEW
Scale: 1/4" = 1'-0"

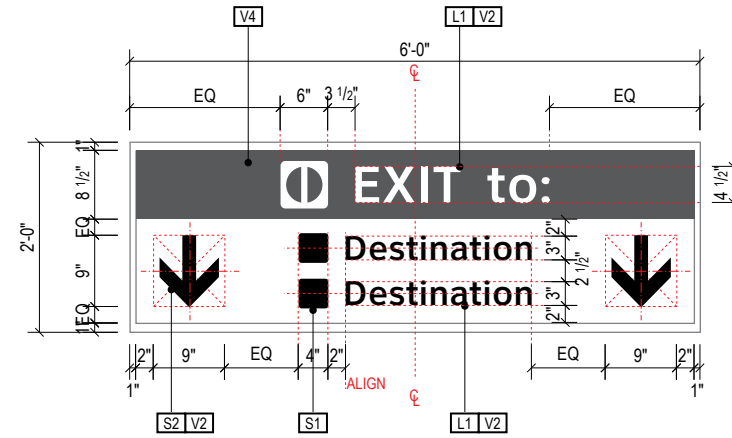

A DETAIL A: Face Layout
Scale: 1/2" = 1'-0"

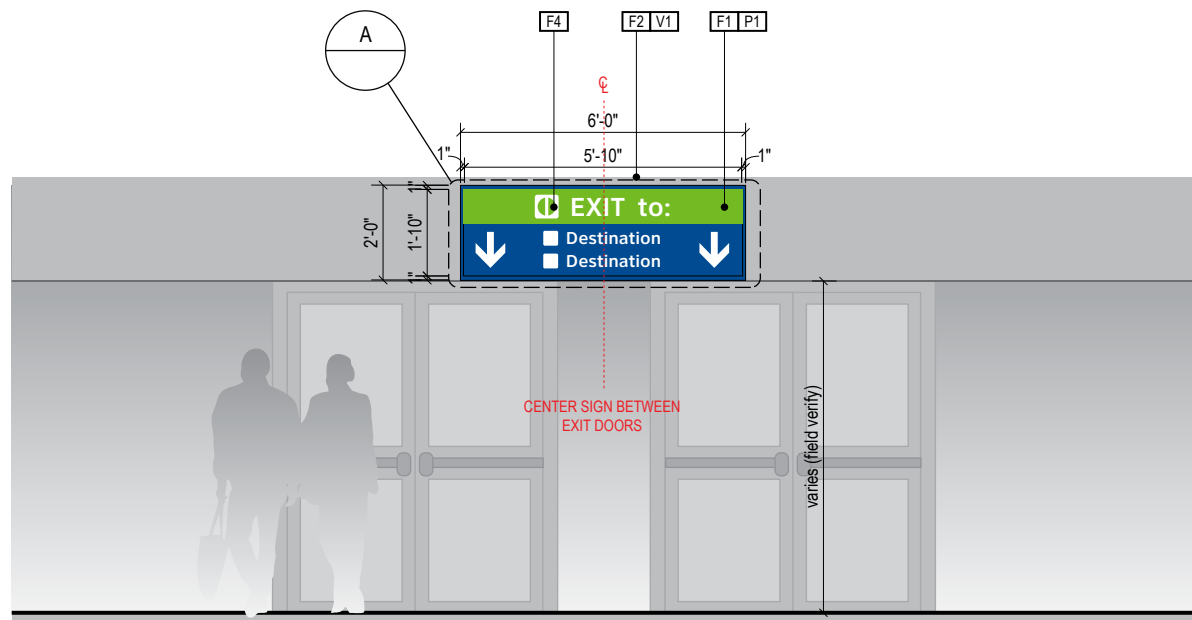

NOTE: Architectural conditions vary per install location; field verify

2 ELEVATION
Scale: 1/4" = 1'-0"

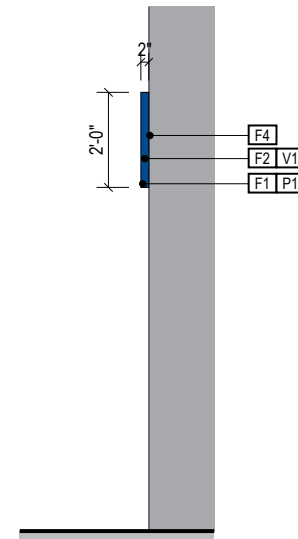

3 END VIEW
Scale: 1/4" = 1'-0"

GENERAL NOTES

- All final design, engineering, and amount/sizing of structural sign support elements, material types/thicknesses, dimensions, and attachment methods shall be performed and approved by a licensed engineer to meet or exceed all applicable local and national codes.
- Final engineering, dimensions, materials, and fabrication are the responsibility of the Fabricator to ensure the highest quality fit and finish for all components of the completed product. All final detailing and specifications to be provided by the Fabricator within their final approved fabrication-ready shop drawings.
- Wherever dissimilar metals are in contact, always separate contact surfaces prior to assembly or installation with the necessary protective coatings/gaskets/washers to prevent galvanic corrosion.
- Final fabrication methods, quality and fit/finish to be reviewed and approved by DFW Airport Planning Department and wayfinding/architecture Design Consultants thru prototype reviews prior to final production run/installation processes (see Performance Specifications for details).
- Colors shown are for reference only, and are subject to the limitations of the printing process and/or variance of electronic RGB screen displays. Refer to color system swatches and/or final finish samples for accurate reference.
- Messages shown here are general placeholders only. See graphic message schedules for specific messaging by location and sign type.

FABRICATION INTENT NOTES

- F1** SIGN CABINET/FRAME: modular fabricated internal illuminated edge-lit sign module cabinet constructed of extruded aluminum and cast aluminum components with concealed internal welds; removable sign face and light modules; fabricated aluminum support frame with welded mitered corners and slotted mounting holes to accept sign mounting brackets; fabricated aluminum sign mounting frame with tapered side end cover panels, attached with aluminum pin and clip system; power feed/units hidden behind mounting frame with access holes in back for wall mounting; powdercoat all exposed surfaces of sign cabinet/support frame/mounting frame to match P1, satin finish
- F2** SIGN FACE: fabricated sign face assembly module constructed of extruded aluminum frame and concealed internal welds; faces are 3/16" white acrylic with 1st surface applied V1 vinyl film, graphics reversed out of blue (white is exposed white acrylic cut-thru blue film); faces illuminated with light panel assembly using LED edge-lit clear inscribed acrylic diffuser and self-contained technology (including electronics, extruded frame and diffuser)
- F3** TRIM: .080 fabricated aluminum trim piece with closed ends; detachable and mounted with keyholes/studs and set screws; paint all exposed surfaces to match P2, satin finish
- F4** MOUNTING: mount to wall structural elements with connection system as installation location conditions require (Fabricator to coordinate connection location/type of structural elements with General Contractor); paint all exposed surfaces to match P1, satin finish

GRAPHICS / COLORS / DECORATION NOTES

- L1** Typeface: font = ClearviewText Medium
- S1** Universal Symbols: AIGA style symbol artwork
- S2** Arrow(s): use only official DFW Airport wayfinding arrow artwork
- VINYL (FILM):**
- V1** Blue: 3M EC 7725-37 Sapphire Blue
- V2** White: 3M 7725-20 Opaque Matte White
- V4** Exit Light Green: 3M Opaque Matte to match PMS 368C
- PAINT:**
- P1** Blue: Powder coated to match 3M EC 7725-37, satin finish

WARNING:

This record contains Sensitive Security Information that is controlled under 49 CFR parts 15 and 1520. No part of this record may be disclosed to persons with a "need to know," as defined in 49 CFR parts 15 and 1520, except with the written permission of the Administrator of the Transportation Security Administration or the Secretary of Transportation. Unauthorized release may result in civil penalty or other action. For U.S. government agencies, public disclosure is governed by 5 U.S.C. 552 and 49 CFR parts 15 and 1520.

ILLUMINATION	SIGN TYPE	SIGN FUNCTION	MOUNTING METHOD	GENERAL DESCRIPTION & USE
NON-ILLUMINATED	1-IN.20	IDENTIFICATION	DOOR SIGN	Secondary ID-Door Mounted

GENERAL NOTES

- All final design, engineering, and amount/sizing of structural sign support elements, material types/thicknesses, dimensions, and attachment methods shall be performed and approved by a licensed engineer to meet or exceed all applicable local and national codes.
- Final engineering, dimensions, materials and fabrication are the responsibility of the Fabricator to ensure the highest quality fit and finish for all components of the completed product. All final detailing and specifications to be provided by the Fabricator within their final approved fabrication-ready shop drawings.
- Wherever dissimilar metals are in contact, always separate contact surfaces prior to assembly or installation with the necessary protective coatings/gaskets/washers to prevent galvanic corrosion.
- Final fabrication methods, quality, and fit/finish to be reviewed and approved by DFW Planning Dept. and wayfinding/architecture Design Consultants through prototype reviews prior to final production run/installation processes (see Performance Specifications for details).
- Colors shown are for reference only, and are subject to the limitations of the printing process and/or variance of electronic RGB screen displays. Refer to color system swatches and/or final finish samples for accurate reference.
- Messages shown here are general placeholders only. See graphic message schedules for specific messaging by location and sign type.

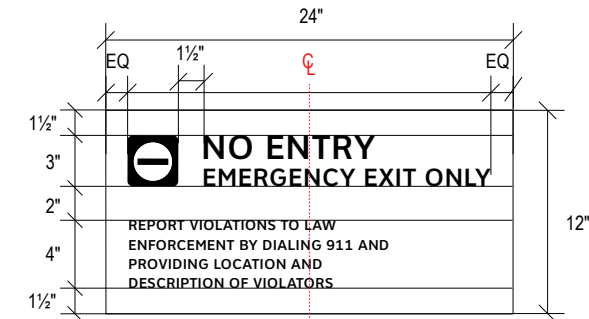
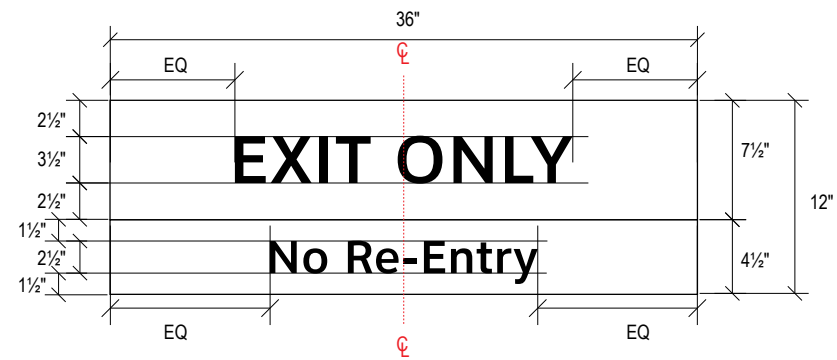
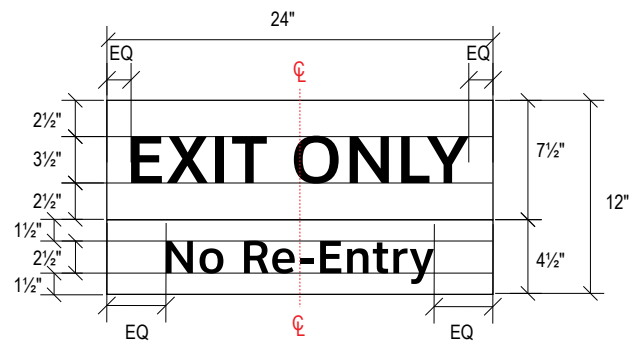

1 DOOR SIGN
Scale: 1/2" = 1'-0"



2 DOOR SIGN
Scale: 1/2" = 1'-0"

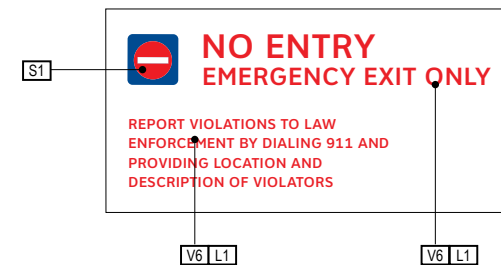

3 DOOR SIGN
Scale: 1/2" = 1'-0"



1 FIELD VIEW
Size: 12"x24"

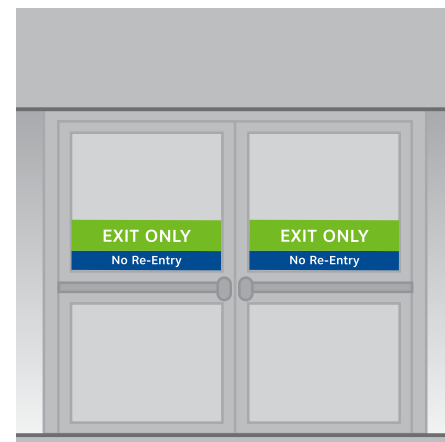

2 FIELD VIEW
Size: 12"x36"

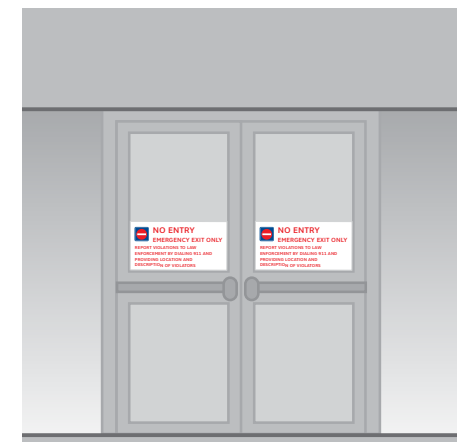

3 FIELD VIEW
Size: 12"x24"

GRAPHICS / COLORS / DECORATION NOTES

- L1** Typeface: font = ClearviewText Medium
- S1** Universal Symbols: AIGA style symbol artwork
- S2** Arrow(s): use only official DFW Airport wayfinding arrow artwork

- VINYL (FILM):**
- V1** Blue: 3M EC 7725-37 Sapphire Blue
 - V2** White: 3M 7725-20 Opaque Matte White
 - V4** Exit Light Green: 3M Opaque Matte to match PMS 368C
 - V6** Safety Red to match Pantone 485C

- PAINT:**
- P1** Blue: Powder coated to match 3M EC 7725-37, satin finish
 - P2** Silver: MAP paint # MP30136, satin finish

WARNING:

This record contains Sensitive Security Information that is controlled under 49 CFR parts 15 and 1520. No part of this record may be disclosed to persons with a "need to know," as defined in 49 CFR parts 15 and 1520, except with the written permission of the Administrator of the Transportation Security Administration or the Secretary of Transportation. Unauthorized release may result in civil penalty or other action. For U.S. government agencies, public disclosure is governed by 5 U.S.C. 552 and 49 CFR parts 15 and 1520.

ILLUMINATION	SIGN TYPE	SIGN FUNCTION	MOUNTING METHOD	GENERAL DESCRIPTION & USE
NON-ILLUMINATED	1-IN.21	IDENTIFICATION	DOOR SIGN	Secondary ID - Blade Mounted

GENERAL NOTES

- All final design, engineering, and amount/sizing of structural sign support elements, material types/thicknesses, dimensions, and attachment methods shall be performed and approved by a licensed engineer to meet or exceed all applicable local and national codes.
- Final engineering, dimensions, materials and fabrication are the responsibility of the Fabricator to ensure the highest quality fit and finish for all components of the completed product. All final detailing and specifications to be provided by the Fabricator within their final approved fabrication-ready shop drawings.
- Wherever dissimilar metals are in contact, always separate contact surfaces prior to assembly or installation with the necessary protective coatings/gaskets/washers to prevent galvanic corrosion.
- Final fabrication methods, quality, and fit/finish to be reviewed and approved by DFW Planning Dept. and wayfinding/architecture Design Consultants through prototype reviews prior to final production run/installation processes (see Performance Specifications for details).
- Colors shown are for reference only, and are subject to the limitations of the printing process and/or variance of electronic RGB screen displays. Refer to color system swatches and/or final finish samples for accurate reference.
- Messages shown here are general placeholders only. See graphic message schedules for specific messaging by location and sign type.

FABRICATION INTENT NOTES

- F1** SIGN CABINET/FRAME: Fabricated aluminum cabinet, powdercoat all exposed surfaces of sign cabinet/support frame/mounting frame to match P1; applied vinyl graphics
- F2** MOUNTING: Fabricated aluminum wall mount bracket with top channel to accept sign cabinet; countersunk screws; mount to wall structural elements with connection system as installation location conditions require (Fabricator to coordinate connection location/type of structural elements with General Contractor); paint all exposed surfaces with Matthews acrylic polyurethane (MAP), P2, satin finish

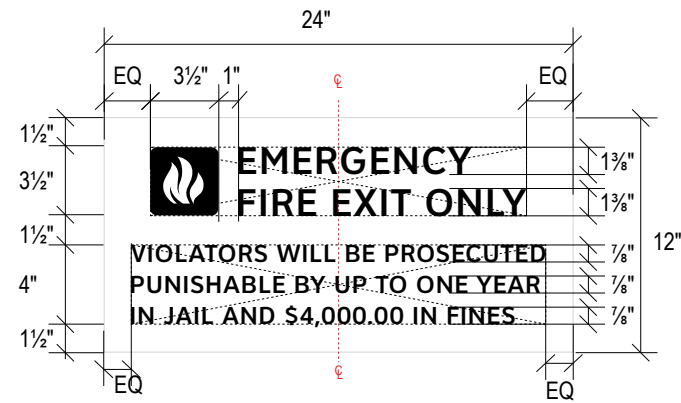

1 DOOR SIGN
Size: 12"x24"

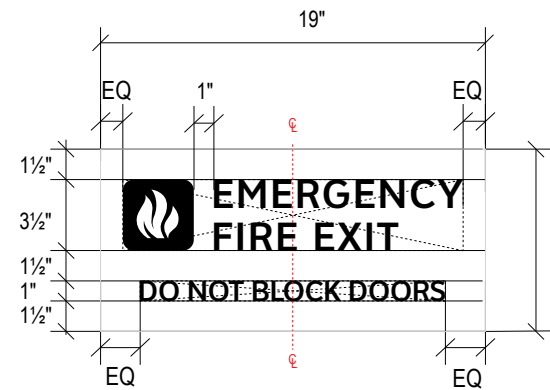

2 DOOR SIGN
Size: 9"x19"

GRAPHICS / COLORS / DECORATION NOTES

- L1** Typeface: font = ClearviewText Medium
- S1** Universal Symbols: AIGA style symbol artwork
- S2** Arrow(s): use only official DFW Airport wayfinding arrow artwork

VINYL (FILM):

- V1** Blue: 3M EC 7725-37 Sapphire Blue
- V2** White: 3M 7725-20 Opaque Matte White
- V4** Exit Light Green: 3M Opaque Matte to match PMS 368C
- V6** Safety Red to match Pantone 485C

PAINT:

- P1** Blue: Powder coated to match 3M EC 7725-37, satin finish
- P2** Silver: MAP paint # MP30136, satin finish

WARNING:

This record contains Sensitive Security Information that is controlled under 49 CFR parts 15 and 1520. No part of this record may be disclosed to persons with a "need to know," as defined in 49 CFR parts 15 and 1520, except with the written permission of the Administrator of the Transportation Security Administration or the Secretary of Transportation. Unauthorized release may result in civil penalty or other action. For U.S. government agencies, public disclosure is governed by 5 U.S.C. 552 and 49 CFR parts 15 and 1520.

ILLUMINATION	SIGN TYPE	SIGN FUNCTION	MOUNTING METHOD	GENERAL DESCRIPTION & USE
INTERNAL	1-DR.27	DIRECTIONAL	FASCIA MOUNT	Interior Vestibule Directional - Fascia Mounted

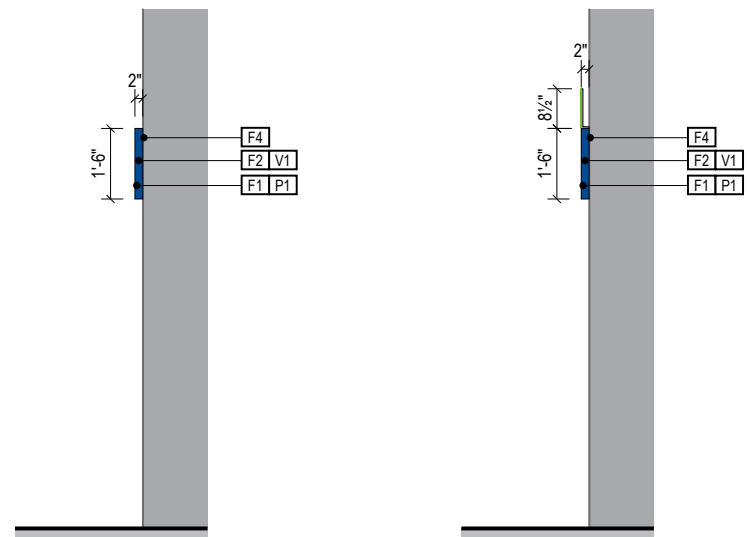

1a END VIEW ELEVATOR
Scale: 1/4" = 1'-0"

1b END VIEW ENTRY/EXIT DOORS
Scale: 1/4" = 1'-0"

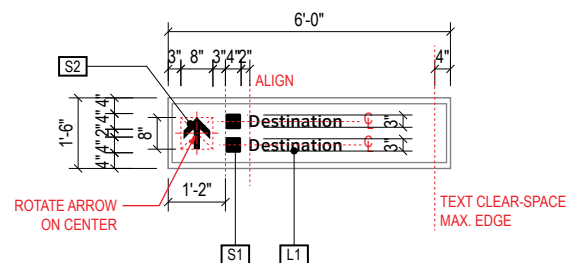

A DETAIL A: Face Layout
Scale: 1/4" = 1'-0"

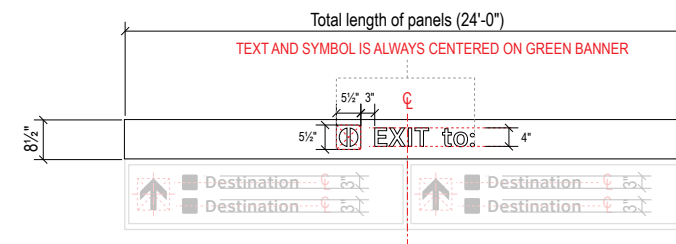

B DETAIL A: Face Layout
Scale: 1/4" = 1'-0"

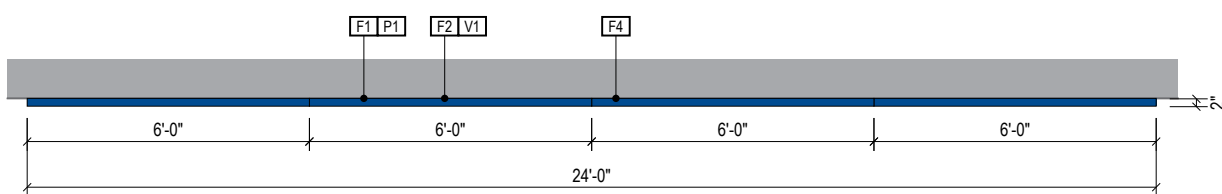

2a PLAN VIEW ELEVATOR
Scale: 1/4" = 1'-0"

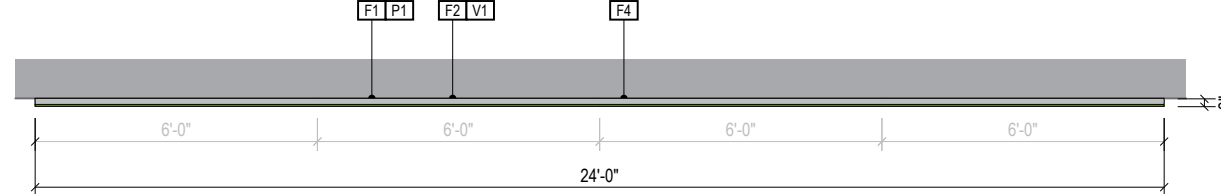

2b PLAN VIEW ENTRY/EXIT DOORS
Scale: 1/4" = 1'-0"

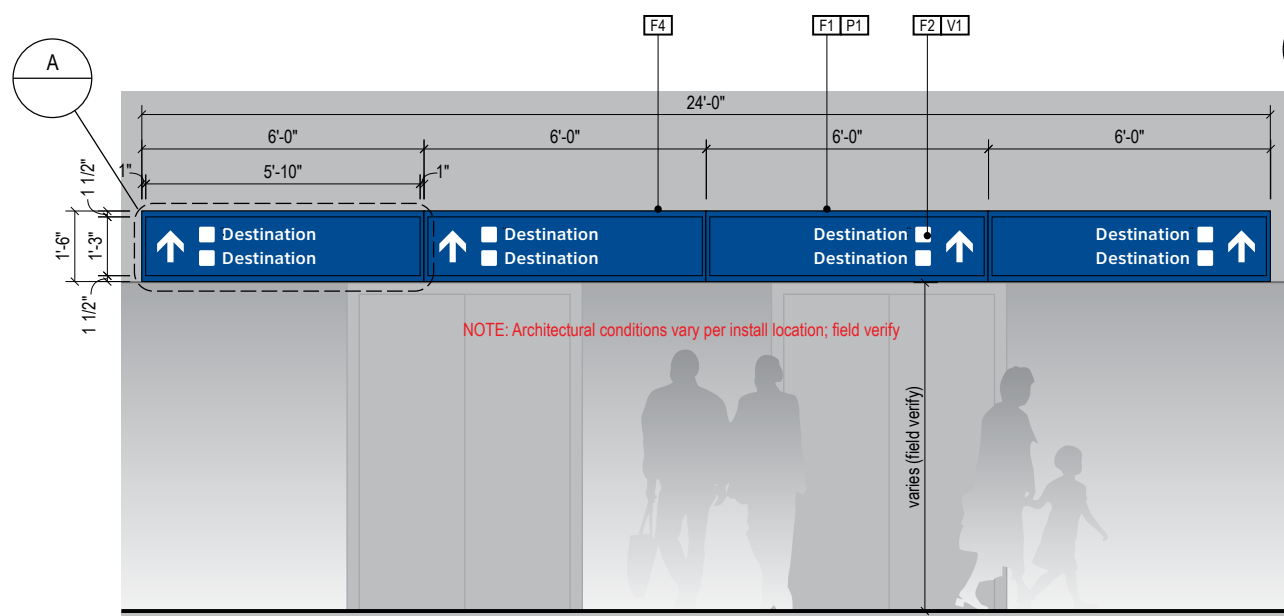

3a ELEVATION ELEVATOR
Scale: 1/4" = 1'-0"

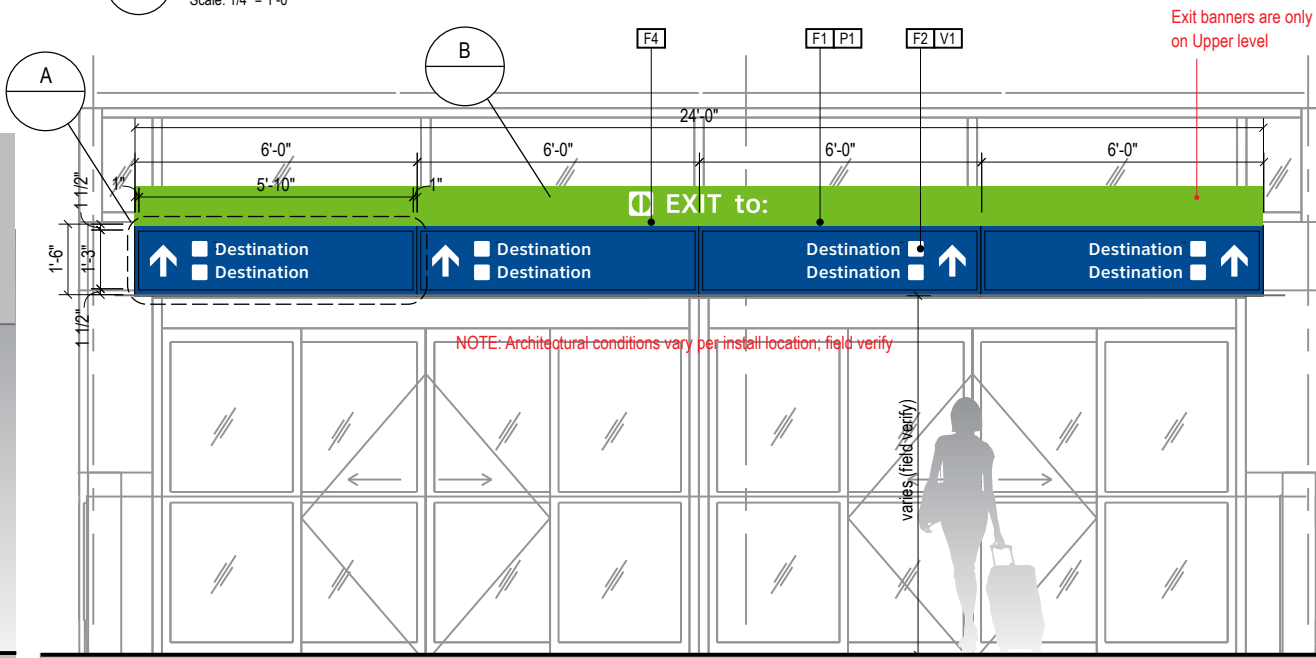

3b ELEVATION ENTRY/EXIT DOORS
Scale: 1/4" = 1'-0"

GENERAL NOTES

- All final design, engineering, and amount/sizing of structural sign support elements, material types/thicknesses, dimensions, and attachment methods shall be performed and approved by a licensed engineer to meet or exceed all applicable local and national codes.
- Final engineering, dimensions, materials, and fabrication are the responsibility of the Fabricator to ensure the highest quality fit and finish for all components of the completed product. All final detailing and specifications to be provided by the Fabricator within their final approved fabrication-ready shop drawings.
- Wherever dissimilar metals are in contact, always separate contact surfaces prior to assembly or installation with the necessary protective coatings/gaskets/washers to prevent galvanic corrosion.
- Final fabrication methods, quality and fit/finish to be reviewed and approved by DFW Airport Planning Department and wayfinding/architecture Design Consultants thru prototype reviews prior to final production run/installation processes (see Performance Specifications for details).
- Colors shown are for reference only, and are subject to the limitations of the printing process and/or variance of electronic RGB screen displays. Refer to color system swatches and/or final finish samples for accurate reference.
- Messages shown here are general placeholders only. See graphic message schedules for specific messaging by location and sign type.

FABRICATION INTENT NOTES

- F1** SIGN CABINET/FRAME: modular fabricated internal illuminated edge-lit sign module cabinet constructed of extruded aluminum and cast aluminum components with concealed internal welds; removable sign face and light modules; fabricated aluminum support frame with welded mitered corners and slotted mounting holes to accept sign mounting brackets; fabricated aluminum sign mounting frame with tapered side end cover panels, attached with aluminum pin and clip system; power feed/units hidden behind mounting frame with access holes in back for wall mounting; powdercoat all exposed surfaces of sign cabinet/support frame/mounting frame to match P1, satin finish
- F2** SIGN FACE: fabricated sign face assembly module constructed of extruded aluminum frame and concealed internal welds; faces are 3/16" white acrylic with 1st surface applied V1 vinyl film, graphics reversed out of blue (white is exposed white acrylic cut-thru blue film); faces illuminated with light panel assembly using LED edge-lit clear inscribed acrylic diffuser and self-contained technology (including electronics, extruded frame and diffuser)
- F3** TRIM: .080 fabricated aluminum trim piece with closed ends; detachable and mounted with keyholes/studs and set screws; paint all exposed surfaces to match P2, satin finish
- F4** MOUNTING: mount to wall structural elements with connection system as installation location conditions require (Fabricator to coordinate connection location/type of structural elements with General Contractor); paint all exposed surfaces to match P1, satin finish

GRAPHICS / COLORS / DECORATION NOTES

- L1** Typeface: font = ClearviewText Medium
- S1** Universal Symbols: AIGA style symbol artwork
- S2** Arrow(s): use only official DFW Airport wayfinding arrow artwork
- VINYL (FILM):**
- V1** Blue: 3M EC 7725-37 Sapphire Blue
- V2** White: 3M 7725-20 Opaque Matte White
- V3** Skylink Yellow: 3M 7725-114 Enamel Receptive
- PAINT:**
- P1** Blue: Powder coated to match 3M EC 7725-37, satin finish

WARNING:

This record contains Sensitive Security Information that is controlled under 49 CFR parts 15 and 1520. No part of this record may be disclosed to persons with a "need to know," as defined in 49 CFR parts 15 and 1520, except with the written permission of the Administrator of the Transportation Security Administration or the Secretary of Transportation. Unauthorized release may result in civil penalty or other action. For U.S. government agencies, public disclosure is governed by 5 U.S.C. 552 and 49 CFR parts 15 and 1520.

ILLUMINATION	SIGN TYPE	SIGN FUNCTION	MOUNTING METHOD	GENERAL DESCRIPTION & USE
INTERNAL	1-DR.28	DIRECTIONAL	FASCIA MOUNT	Interior Vestibule Directional - Fascia Mounted

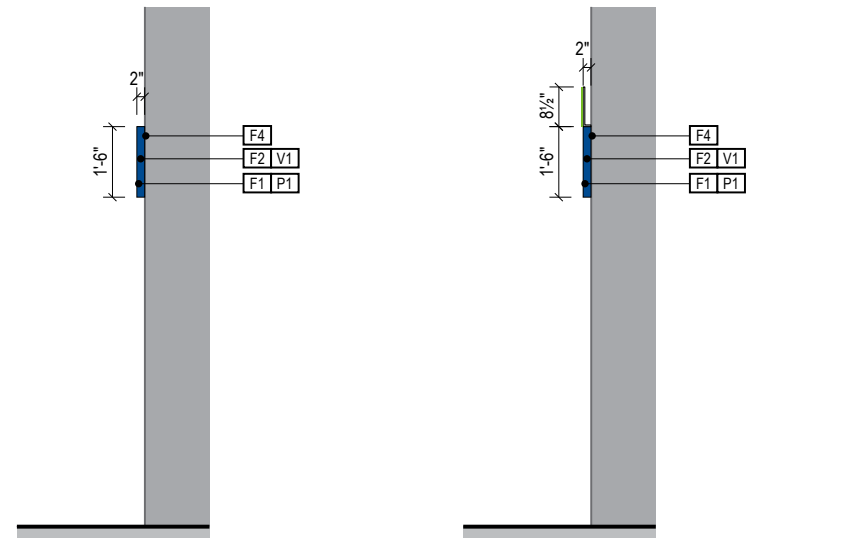

1a END VIEW ELEVATOR
Scale: 1/4" = 1'-0"

1b END VIEW ENTRY/EXIT DOORS
Scale: 1/4" = 1'-0"

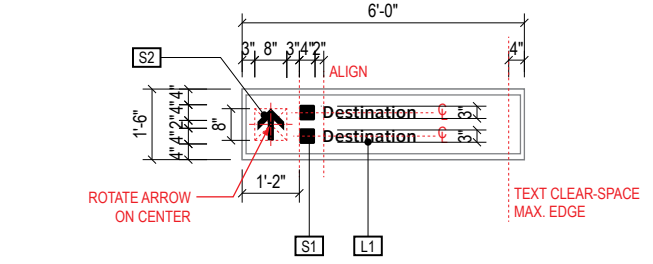

A DETAIL A: Face Layout
Scale: 1/4" = 1'-0"

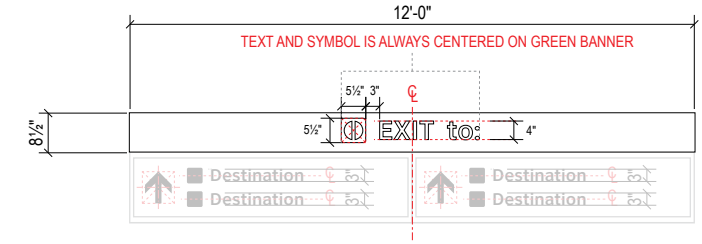

B DETAIL A: Face Layout
Scale: 1/4" = 1'-0"

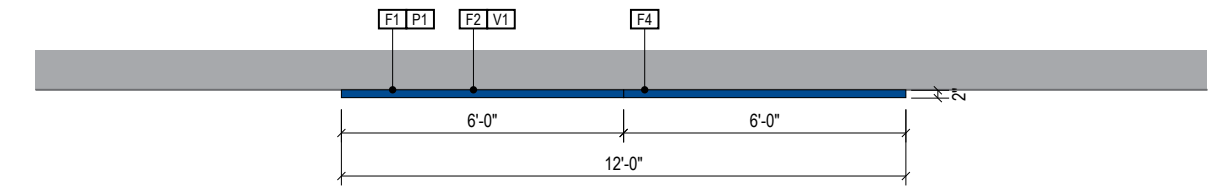

2a PLAN VIEW ELEVATOR
Scale: 1/4" = 1'-0"

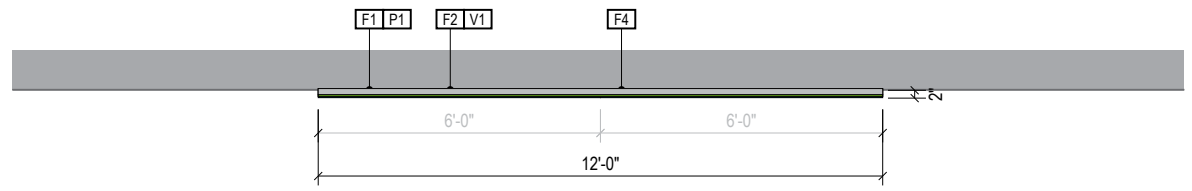

2b PLAN VIEW ENTRY/EXIT DOORS
Scale: 1/4" = 1'-0"

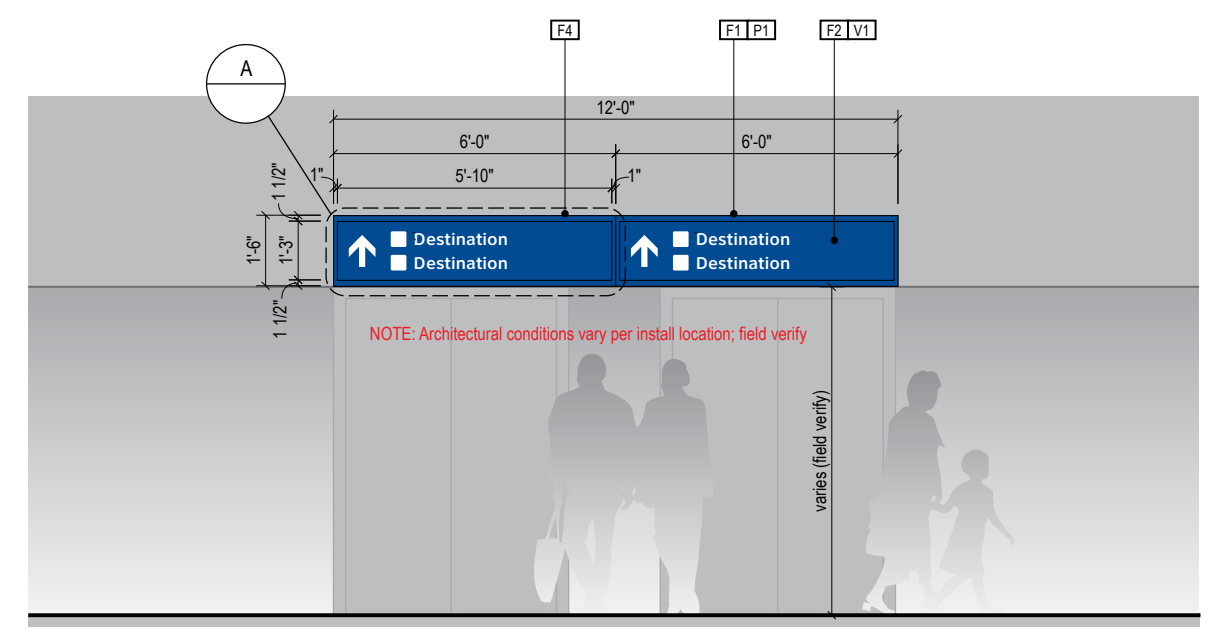

3a ELEVATION ELEVATOR
Scale: 1/4" = 1'-0"

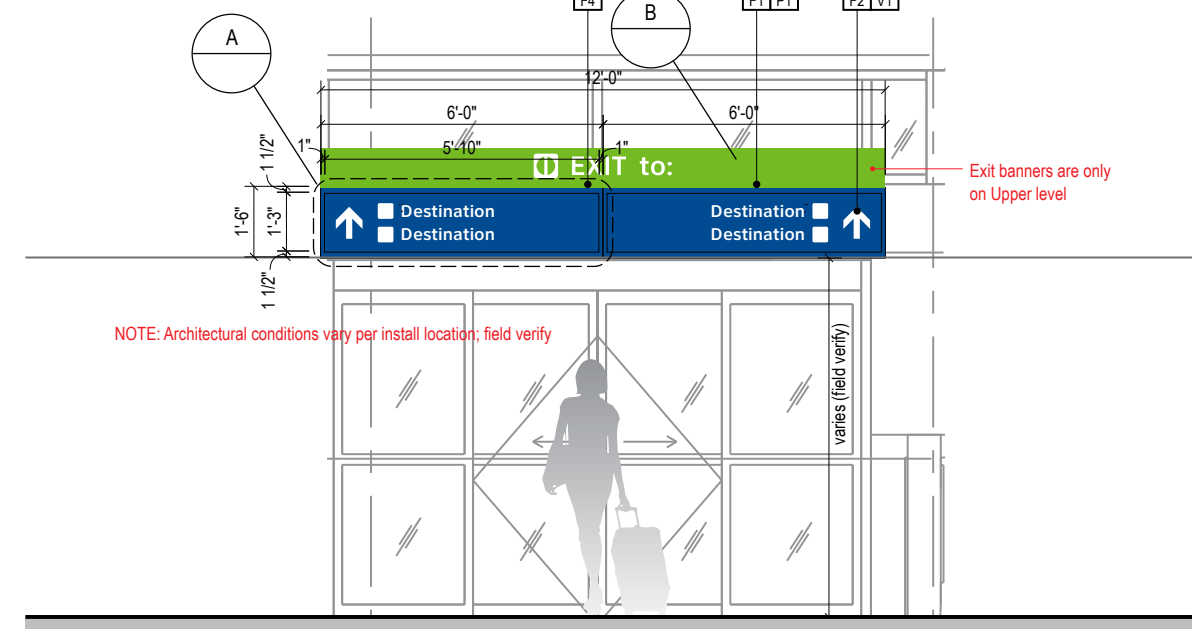

3b ELEVATION ENTRY/EXIT DOORS
Scale: 1/4" = 1'-0"

- GENERAL NOTES**
- All final design, engineering, and amount/sizing of structural sign support elements, material types/thicknesses, dimensions, and attachment methods shall be performed and approved by a licensed engineer to meet or exceed all applicable local and national codes.
 - Final engineering, dimensions, materials, and fabrication are the responsibility of the Fabricator to ensure the highest quality fit and finish for all components of the completed product. All final detailing and specifications to be provided by the Fabricator within their final approved fabrication-ready shop drawings.
 - Wherever dissimilar metals are in contact, always separate contact surfaces prior to assembly or installation with the necessary protective coatings/gaskets/washers to prevent galvanic corrosion.
 - Final fabrication methods, quality and fit/finish to be reviewed and approved by DFW Airport Planning Department and wayfinding/architecture Design Consultants thru prototype reviews prior to final production run/installation processes (see Performance Specifications for details).
 - Colors shown are for reference only, and are subject to the limitations of the printing process and/or variance of electronic RGB screen displays. Refer to color system swatches and/or final finish samples for accurate reference.
 - Messages shown here are general placeholders only. See graphic message schedules for specific messaging by location and sign type.

- FABRICATION INTENT NOTES**
- F1** SIGN CABINET/FRAME: modular fabricated internal illuminated edge-lit sign module cabinet constructed of extruded aluminum and cast aluminum components with concealed internal welds; removable sign face and light modules; fabricated aluminum support frame with welded mitered corners and slotted mounting holes to accept sign mounting brackets; fabricated aluminum sign mounting frame with tapered side end cover panels, attached with aluminum pin and clip system; power feed/units hidden behind mounting frame with access holes in back for wall mounting; powdercoat all exposed surfaces of sign cabinet/support frame/mounting frame to match P1, satin finish
 - F2** SIGN FACE: fabricated sign face assembly module constructed of extruded aluminum frame and concealed internal welds; faces are 3/16" white acrylic with 1st surface applied V1 vinyl film, graphics reversed out of blue (white is exposed white acrylic cut-thru blue film); faces illuminated with light panel assembly using LED edge-lit clear inscribed acrylic diffuser and self-contained technology (including electronics, extruded frame and diffuser)
 - F3** TRIM: .080 fabricated aluminum trim piece with closed ends; detachable and mounted with keyholes/studs and set screws; paint all exposed surfaces to match P2, satin finish
 - F4** MOUNTING: mount to wall structural elements with connection system as installation location conditions require (Fabricator to coordinate connection location/type of structural elements with General Contractor); paint all exposed surfaces to match P1, satin finish

- GRAPHICS / COLORS / DECORATION NOTES**
- L1** Typeface: font = ClearviewText Medium
 - S1** Universal Symbols: AIGA style symbol artwork
 - S2** Arrow(s): use only official DFW Airport wayfinding arrow artwork
 - VINYL (FILM):**
 - V1** Blue: 3M EC 7725-37 Sapphire Blue
 - V2** White: 3M 7725-20 Opaque Matte White
 - V3** Skylink Yellow: 3M 7725-114 Enamel Receptive
 - PAINT:**
 - P1** Blue: Powder coated to match 3M EC 7725-37, satin finish

ILLUMINATION	SIGN TYPE	SIGN FUNCTION	MOUNTING METHOD	GENERAL DESCRIPTION & USE
INTERNAL	1-DR.29	DIRECTIONAL	FASCIA MOUNT	Interior Vestibule Directional - Fascia Mounted

GENERAL NOTES

- All final design, engineering, and amount/sizing of structural sign support elements, material types/thicknesses, dimensions, and attachment methods shall be performed and approved by a licensed engineer to meet or exceed all applicable local and national codes.
- Final engineering, dimensions, materials, and fabrication are the responsibility of the Fabricator to ensure the highest quality fit and finish for all components of the completed product. All final detailing and specifications to be provided by the Fabricator within their final approved fabrication-ready shop drawings.
- Wherever dissimilar metals are in contact, always separate contact surfaces prior to assembly or installation with the necessary protective coatings/gaskets/washers to prevent galvanic corrosion.
- Final fabrication methods, quality and fit/finish to be reviewed and approved by DFW Airport Planning Department and wayfinding/architecture Design Consultants thru prototype reviews prior to final production run/installation processes (see Performance Specifications for details).
- Colors shown are for reference only, and are subject to the limitations of the printing process and/or variance of electronic RGB screen displays. Refer to color system swatches and/or final finish samples for accurate reference.
- Messages shown here are general placeholders only. See graphic message schedules for specific messaging by location and sign type.

FABRICATION INTENT NOTES

- F1** SIGN CABINET/FRAME: modular fabricated internal illuminated edge-lit sign module cabinet constructed of extruded aluminum and cast aluminum components with concealed internal welds; removable sign face and light modules; fabricated aluminum support frame with welded mitered corners and slotted mounting holes to accept sign mounting brackets; fabricated aluminum sign mounting frame with tapered side end cover panels, attached with aluminum pin and clip system; power feed/units hidden behind mounting frame with access holes in back for wall mounting; powdercoat all exposed surfaces of sign cabinet/support frame/mounting frame to match P1, satin finish
- F2** SIGN FACE: fabricated sign face assembly module constructed of extruded aluminum frame and concealed internal welds; faces are 3/16" white acrylic with 1st surface applied V1 vinyl film, graphics reversed out of blue (white is exposed white acrylic cut-thru blue film); faces illuminated with light panel assembly using LED edge-lit clear inscribed acrylic diffuser and self-contained technology (including electronics, extruded frame and diffuser)
- F3** TRIM: .080 fabricated aluminum trim piece with closed ends; detachable and mounted with keyholes/studs and set screws; paint all exposed surfaces to match P2, satin finish
- F4** MOUNTING: mount to wall structural elements with connection system as installation location conditions require (Fabricator to coordinate connection location/type of structural elements with General Contractor); paint all exposed surfaces to match P1, satin finish

GRAPHICS / COLORS / DECORATION NOTES

- L1** Typeface: font = ClearviewText Medium
 - S1** Universal Symbols: AIGA style symbol artwork
 - S2** Arrow(s): use only official DFW wayfinding arrow artwork
- VINYL (FILM):
- V1** Blue: 3M EC 7725-37 Sapphire Blue
 - V2** White: 3M 7725-20 Opaque Matte White
 - V3** Skylink Yellow: 3M 7725-114 Enamel Receptive
- PAINT:
- P1** Blue: Powder coated to match 3M EC 7725-37, satin finish

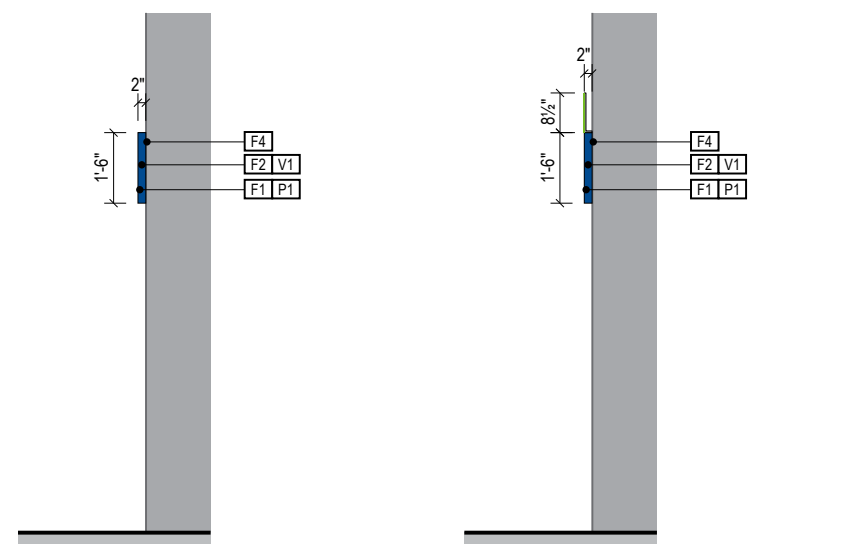

A DETAIL A: Face Layout
Scale: 1/4" = 1'-0"

B DETAIL A: Face Layout
Scale: 1/4" = 1'-0"

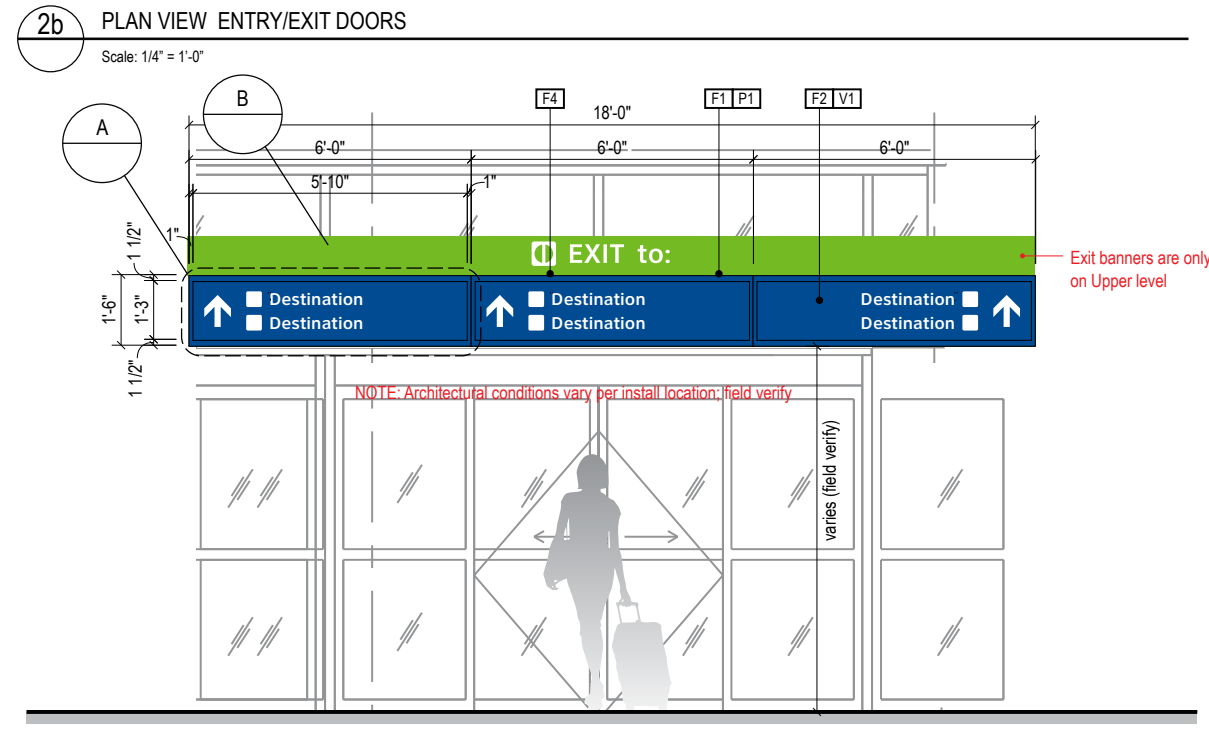
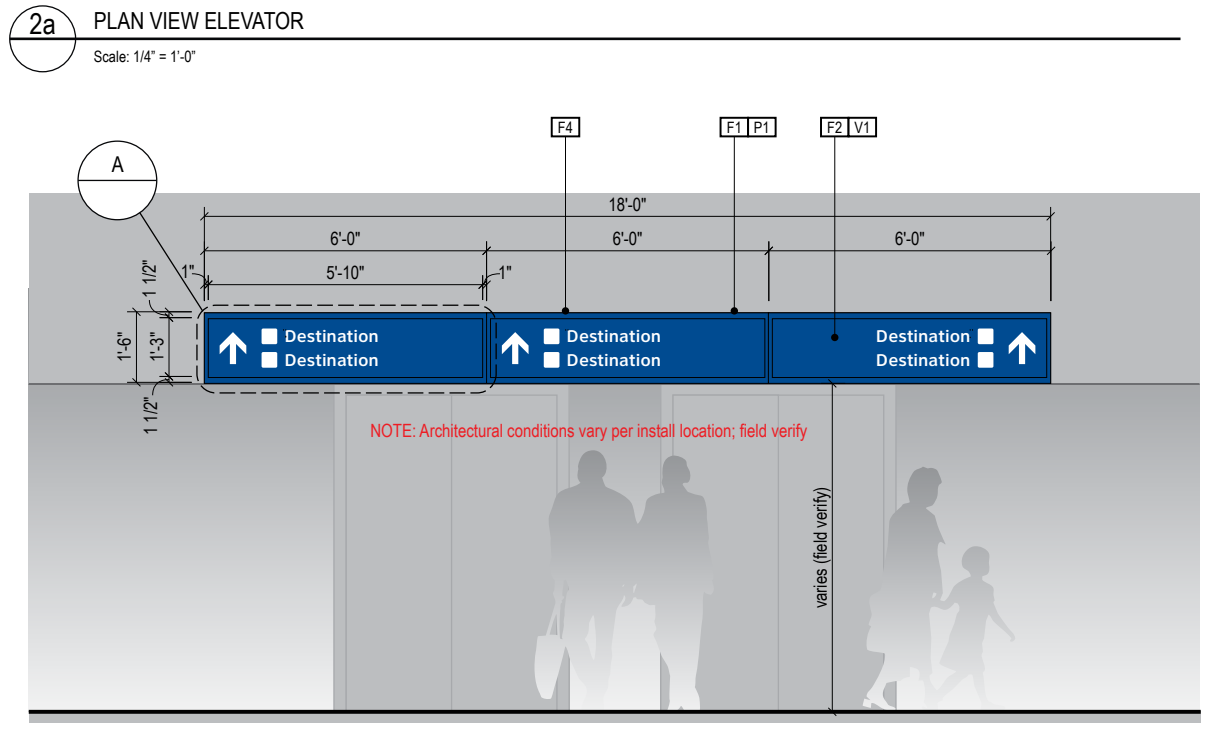
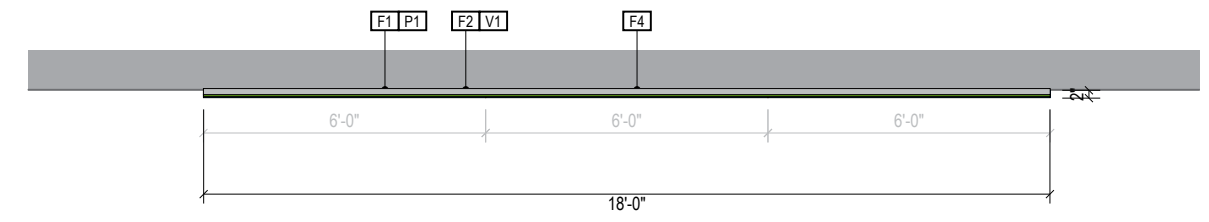
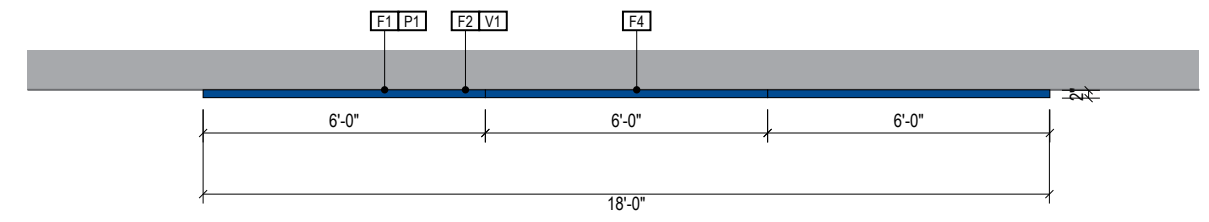
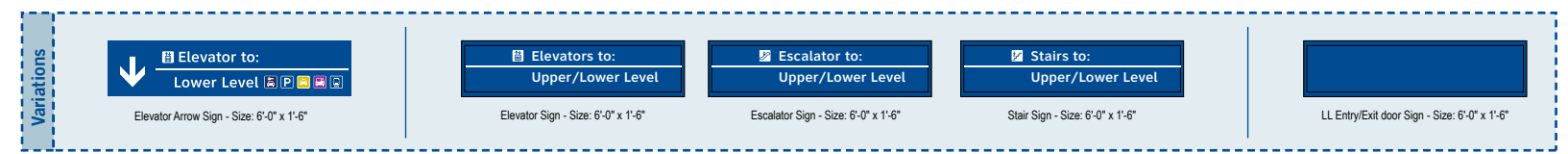

ILLUMINATION	SIGN TYPE	SIGN FUNCTION	MOUNTING METHOD	GENERAL DESCRIPTION & USE
INTERNAL	1-DR.30	DIRECTIONAL	FASCIA MOUNT	Elevator Directional - Fascia Mounted

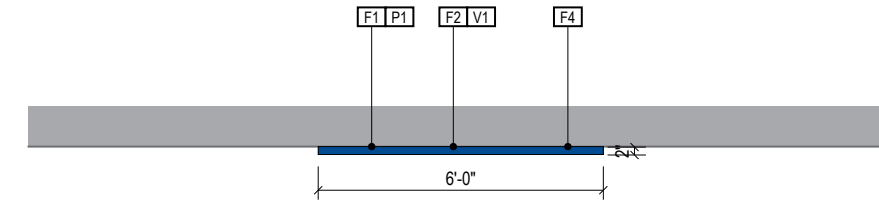

1 PLAN VIEW
Scale: 1/4" = 1'-0"

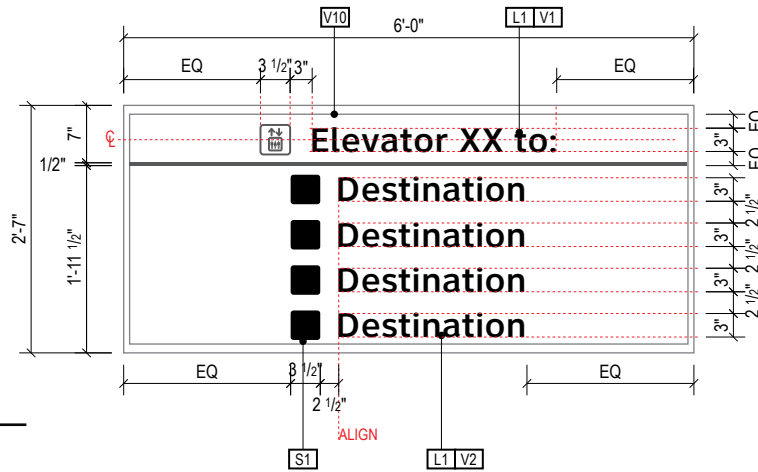

A DETAIL A: Face Layout
Scale: 1/2" = 1'-0"

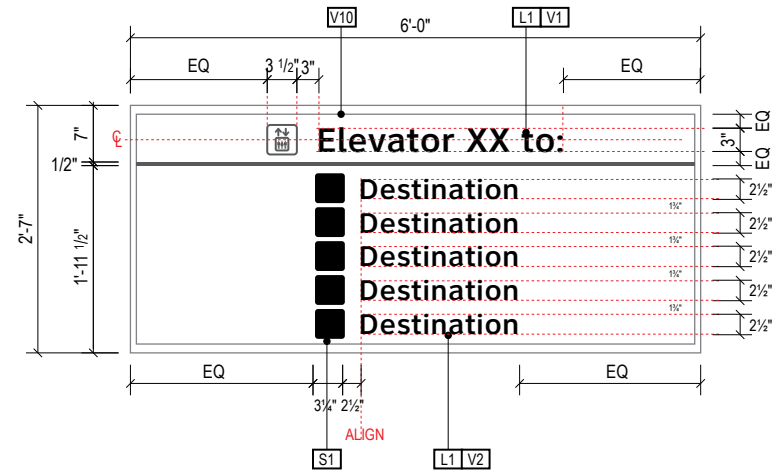

B DETAIL B: Face Layout
Scale: 1/2" = 1'-0"

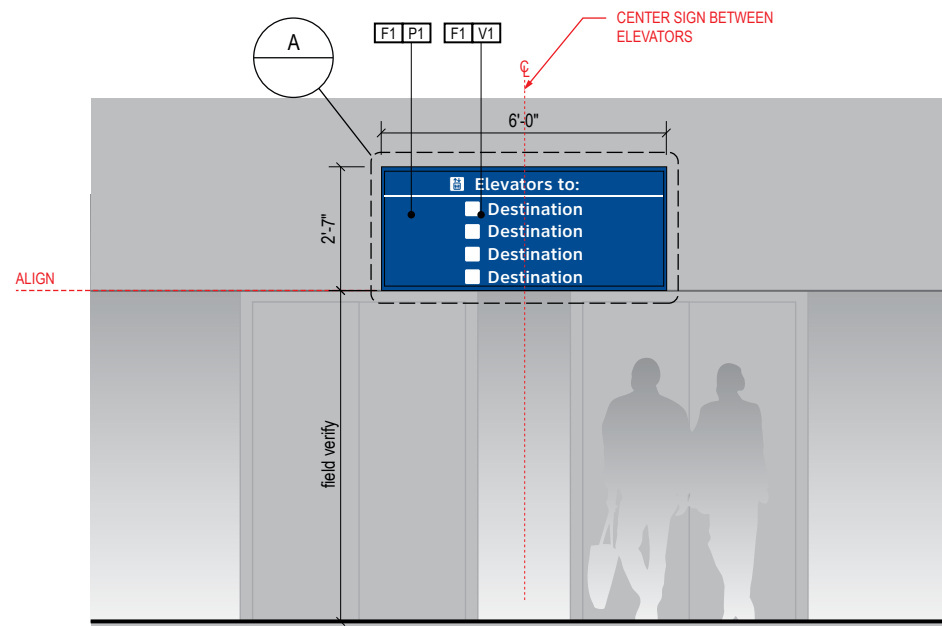

NOTE: Architectural conditions vary per install location; field verify

2 ELEVATION - DUAL ELEVATOR CONDITION
Scale: 1/4" = 1'-0"

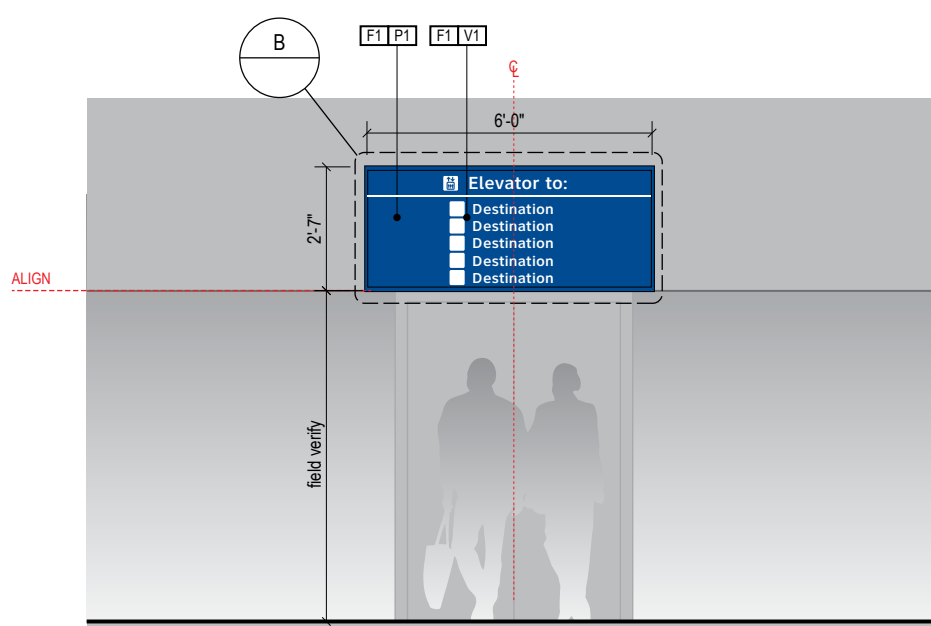

NOTE: Architectural conditions vary per install location; field verify

3 ELEVATION - SINGLE ELEVATOR CONDITION
Scale: 1/4" = 1'-0"

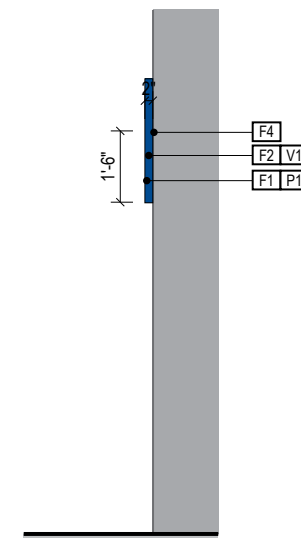

4 END VIEW
Scale: 1/4" = 1'-0"

GENERAL NOTES

- All final design, engineering, and amount/sizing of structural sign support elements, material types/thicknesses, dimensions, and attachment methods shall be performed and approved by a licensed engineer to meet or exceed all applicable local and national codes.
- Final engineering, dimensions, materials, and fabrication are the responsibility of the Fabricator to ensure the highest quality fit and finish for all components of the completed product. All final detailing and specifications to be provided by the Fabricator within their final approved fabrication-ready shop drawings.
- Whenever dissimilar metals are in contact, always separate contact surfaces prior to assembly or installation with the necessary protective coatings/gaskets/washers to prevent galvanic corrosion.
- Final fabrication methods, quality and fit/finish to be reviewed and approved by DFW Airport Planning Department and wayfinding/architecture Design Consultants thru prototype reviews prior to final production run/installation processes (see Performance Specifications for details).
- Colors shown are for reference only, and are subject to the limitations of the printing process and/or variance of electronic RGB screen displays. Refer to color system swatches and/or final finish samples for accurate reference.
- Messages shown here are general placeholders only. See graphic message schedules for specific messaging by location and sign type.

FABRICATION INTENT NOTES

- F1** SIGN CABINET/FRAME: modular fabricated internal illuminated edge-lit sign module cabinet constructed of extruded aluminum and cast aluminum components with concealed internal welds; removable sign face and light modules; fabricated aluminum support frame with welded mitered corners and slotted mounting holes to accept sign mounting brackets; fabricated aluminum sign mounting frame with tapered side end cover panels, attached with aluminum pin and clip system; power feed/units hidden behind mounting frame with access holes in back for wall mounting; powdercoat all exposed surfaces of sign cabinet/support frame/mounting frame to match P1, satin finish
- F2** SIGN FACE: fabricated sign face assembly module constructed of extruded aluminum frame and concealed internal welds; faces are 3/16" white acrylic with 1st surface applied V1 vinyl film, graphics reversed out of blue (white is exposed white acrylic cut-thru blue film); faces illuminated with light panel assembly using LED edge-lit clear inscribed acrylic diffuser and self-contained technology (including electronics, extruded frame and diffuser)
- F3** TRIM: .080 fabricated aluminum trim piece with closed ends; detachable and mounted with keyholes/studs and set screws; paint all exposed surfaces to match P2, satin finish
- F4** MOUNTING: mount to wall structural elements with connection system as installation location conditions require (Fabricator to coordinate connection location/type of structural elements with General Contractor); paint all exposed surfaces to match P1, satin finish

GRAPHICS / COLORS / DECORATION NOTES

- L1** Typeface: font = ClearviewText Medium
- S1** Universal Symbols: AIGA style symbol artwork

- VINYL (FILM):**
- V1** Blue: 3M EC 7725-37 Sapphire Blue
 - V2** White: 3M 7725-20 Opaque Matte White
 - V10** Light Gray: 3M Opaque Matte to match PMS Cool Gray 1C
- PAINT:**
- P1** Blue: Powder coated to match 3M EC 7725-37, satin finish

WARNING:

This record contains Sensitive Security Information that is controlled under 49 CFR parts 15 and 1520. No part of this record may be disclosed to persons with a "need to know," as defined in 49 CFR parts 15 and 1520, except with the written permission of the Administrator of the Transportation Security Administration or the Secretary of Transportation. Unauthorized release may result in civil penalty or other action. For U.S. government agencies, public disclosure is governed by 5 U.S.C. 552 and 49 CFR parts 15 and 1520.

ILLUMINATION	SIGN TYPE	SIGN FUNCTION	MOUNTING METHOD	GENERAL DESCRIPTION & USE
NON-ILLUMINATED	1-DR.31	DIRECTIONAL	WALL MOUNT	Elevator Directory - Wall Mounted

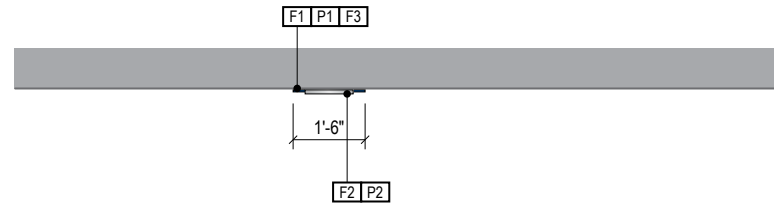

1 PLAN VIEW
Scale: 1/4" = 1'-0"

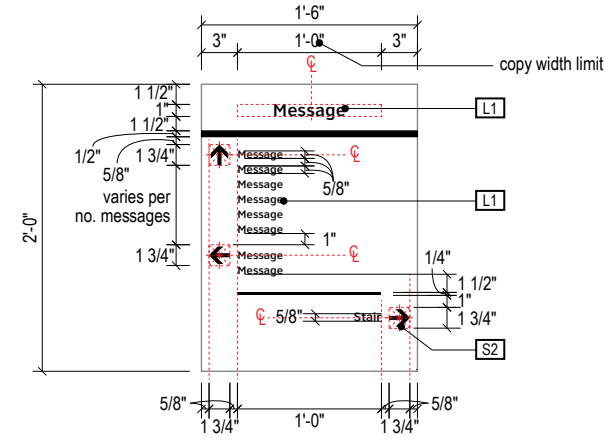

A DETAIL A: Face Layout
Scale: 3/4" = 1'-0"

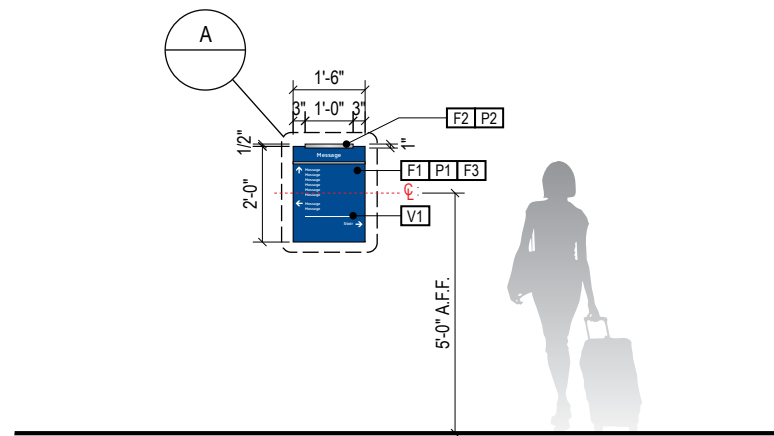

2 ELEVATION
Scale: 1/4" = 1'-0"

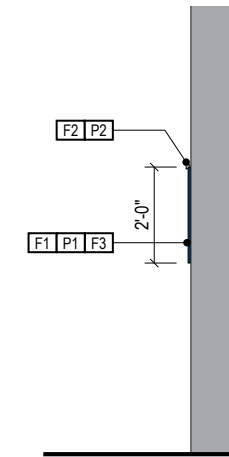

3 END VIEW
Scale: 1/4" = 1'-0"

GENERAL NOTES

- All final design, engineering, and amount/sizing of structural sign support elements, material types/thicknesses, dimensions and attachment methods shall be performed and approved by a licensed engineer to meet or exceed all applicable local and national codes.
- Final engineering, dimensions, materials and fabrication are the responsibility of the Fabricator to ensure the highest quality fit and finish for all components of the completed product. All final detailing and specifications to be provided by the Fabricator within their final approved fabrication-ready shop drawings.
- Wherever dissimilar metals are in contact, always separate contact surfaces prior to assembly or installation with the necessary protective coatings/gaskets/washers to prevent galvanic corrosion.
- Final fabrication methods, quality and fit/finish to be reviewed and approved by DFW Planning Dept. and wayfinding/architecture Design Consultants through prototype reviews prior to final production run/installation processes (see Performance Specifications for details).
- Colors shown are for reference only, and are subject to the limitations of the printing process and/or variance of electronic RGB screen displays. Refer to color system swatches and/or final finish samples for accurate reference.
- Messages shown here are general placeholders only. See graphic message schedules for specific messaging by location and sign type.

FABRICATION INTENT NOTES

- F1** SIGN FACE: 3/8" thick aluminum panel; paint all exposed surfaces of sign face to match P1, satin finish
- F2** TRIM: fabricated aluminum trim piece; attached to sign face panel with LORD adhesive; paint all exposed surfaces to match P2, satin finish
- F3** MOUNTING: mount 2nd surface of sign face to wall with .125" diameter threaded studs, DF tape and silicone as required

GRAPHICS / COLORS / DECORATION NOTES

- L1** Typeface: font = ClearviewText Medium
 - S1** Universal Symbols: AIGA style symbol artwork
 - S2** Arrow(s): use only official DFW Airport wayfinding arrow artwork
 - V1** VINYL (FILM): Blue: 3M EC 7725-37 Sapphire Blue
 - V2** White: 3M 7725-20 Opaque Matte White
 - V3** Skylink Yellow: 3M 7725-114 Enamel Receptive
- PAINT:**
- P1** Blue: Powder coated to match 3M EC 7725-37, satin finish
 - P2** Silver: MAP paint # MP30136, satin finish

WARNING:

This record contains Sensitive Security Information that is controlled under 49 CFR parts 15 and 1520. No part of this record may be disclosed to persons with a "need to know," as defined in 49 CFR parts 15 and 1520, except with the written permission of the Administrator of the Transportation Security Administration or the Secretary of Transportation. Unauthorized release may result in civil penalty or other action. For U.S. government agencies, public disclosure is governed by 5 U.S.C. 552 and 49 CFR parts 15 and 1520.

ILLUMINATION	SIGN TYPE	SIGN FUNCTION	MOUNTING METHOD	GENERAL DESCRIPTION & USE
NON-ILLUMINATED	1-DR-32	DIRECTIONAL	WALL MOUNT	Elevator Directory - Wall Mounted

GENERAL NOTES

- All final design, engineering, and amount/sizing of structural sign support elements, material types/thicknesses, dimensions and attachment methods shall be performed and approved by a licensed engineer to meet or exceed all applicable local and national codes.
- Final engineering, dimensions, materials and fabrication are the responsibility of the Fabricator to ensure the highest quality fit and finish for all components of the completed product. All final detailing and specifications to be provided by the Fabricator within their final approved fabrication-ready shop drawings.
- Wherever dissimilar metals are in contact, always separate contact surfaces prior to assembly or installation with the necessary protective coatings/gaskets/washers to prevent galvanic corrosion.
- Final fabrication methods, quality and fit/finish to be reviewed and approved by DFW Planning Dept. and wayfinding/architecture Design Consultants through prototype reviews prior to final production run/installation processes (see Performance Specifications for details).
- Colors shown are for reference only, and are subject to the limitations of the printing process and/or variance of electronic RGB screen displays. Refer to color system swatches and/or final finish samples for accurate reference.
- Messages shown here are general placeholders only. See graphic message schedules for specific messaging by location and sign type.

FABRICATION INTENT NOTES

- F1** SIGN FACE: 3/8" thick aluminum panel; paint all exposed surfaces of sign face to match P1, satin finish
- F2** TRIM: fabricated aluminum trim piece; attached to sign face panel with LORD adhesive; paint all exposed surfaces to match P2, satin finish
- F3** MOUNTING: mount 2nd surface of sign face to wall with .125" diameter threaded studs, DF tape and silicone as required

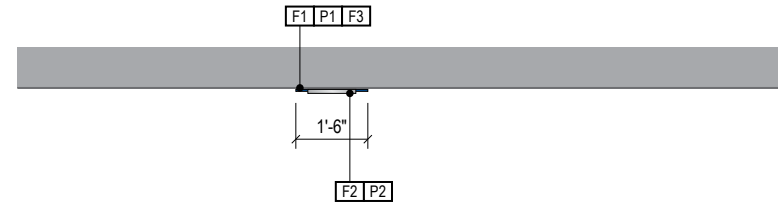

1 PLAN VIEW
Scale: 1/4" = 1'-0"

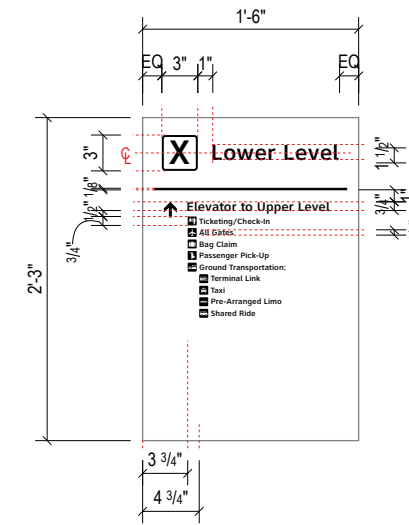

A DETAIL A: Face Layout
Scale: 3/4" = 1'-0"

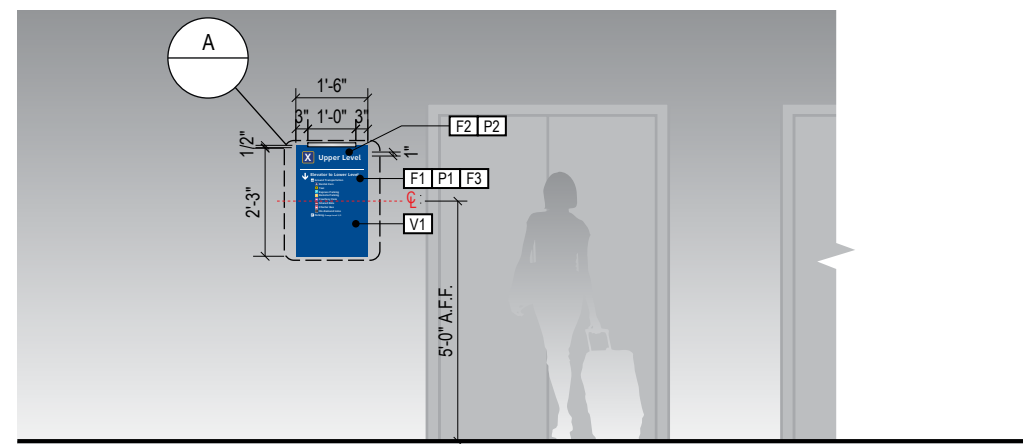

2 ELEVATION
Scale: 1/4" = 1'-0"

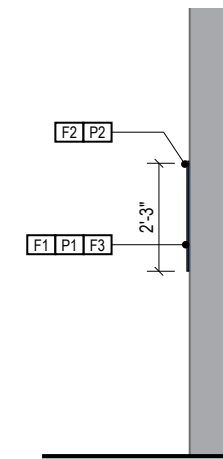

3 END VIEW
Scale: 1/4" = 1'-0"

GRAPHICS / COLORS / DECORATION NOTES

- L1** Typeface: font = ClearviewText Medium
- S1** Universal Symbols: AIGA style symbol artwork
- S2** Arrow(s): use only official DFW Airport wayfinding arrow artwork
VINYL (FILM):
V1 Blue: 3M EC 7725-37 Sapphire Blue
V2 White: 3M 7725-20 Opaque Matte White
V3 Skylink Yellow: 3M 7725-114 Enamel Receptive
- PAINT:**
P1 Blue: Powder coated to match 3M EC 7725-37, satin finish
P2 Silver: MAP paint # MP30136, satin finish

WARNING:

This record contains Sensitive Security Information that is controlled under 49 CFR parts 15 and 1520. No part of this record may be disclosed to persons with a "need to know," as defined in 49 CFR parts 15 and 1520, except with the written permission of the Administrator of the Transportation Security Administration or the Secretary of Transportation. Unauthorized release may result in civil penalty or other action. For U.S. government agencies, public disclosure is governed by 5 U.S.C. 552 and 49 CFR parts 15 and 1520.

ILLUMINATION	SIGN TYPE	SIGN FUNCTION	MOUNTING METHOD	GENERAL DESCRIPTION & USE
NON-ILLUMINATED	1-DR.33	DIRECTIONAL	WALL MOUNT	Elevator Directory - Wall Mounted



1 PLAN VIEW
Scale: 1/4" = 1'-0"

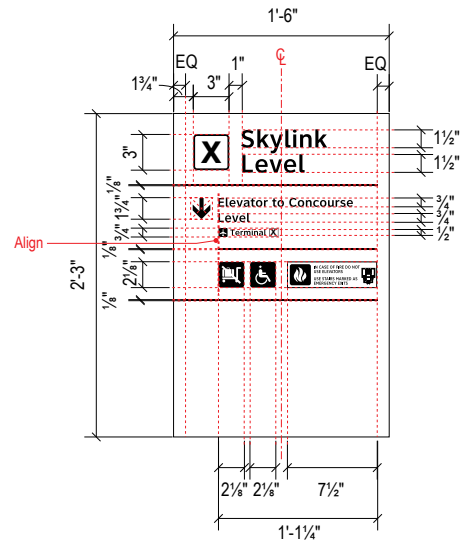

A DETAIL A: Face Layout
Scale: 3/4" = 1'-0"

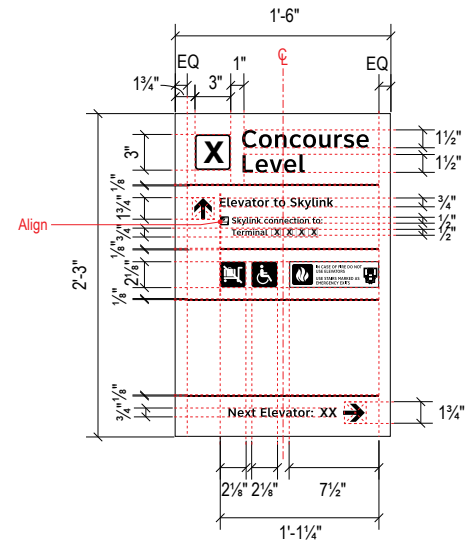

B DETAIL B: Face Layout
Scale: 3/4" = 1'-0"

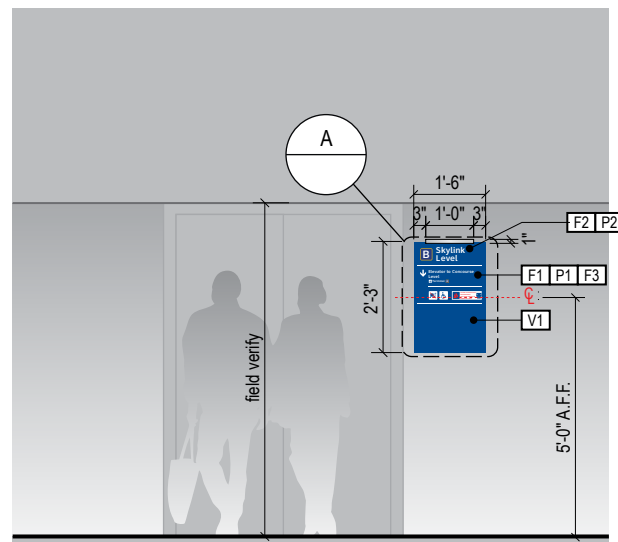

NOTE: Architectural conditions vary per install location; field verify

2 ELEVATION
Scale: 1/4" = 1'-0"

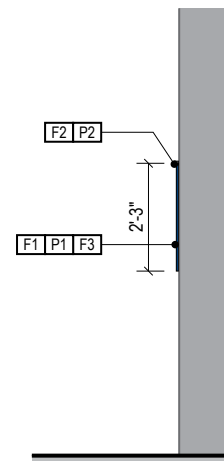

3 END VIEW
Scale: 1/4" = 1'-0"

GENERAL NOTES

- All final design, engineering, and amount/sizing of structural sign support elements, material types/thicknesses, dimensions and attachment methods shall be performed and approved by a licensed engineer to meet or exceed all applicable local and national codes.
- Final engineering, dimensions, materials and fabrication are the responsibility of the Fabricator to ensure the highest quality fit and finish for all components of the completed product. All final detailing and specifications to be provided by the Fabricator within their final approved fabrication-ready shop drawings.
- Wherever dissimilar metals are in contact, always separate contact surfaces prior to assembly or installation with the necessary protective coatings/gaskets/washers to prevent galvanic corrosion.
- Final fabrication methods, quality and fit/finish to be reviewed and approved by DFW Planning Dept. and wayfinding/architecture Design Consultants through prototype reviews prior to final production run/installation processes (see Performance Specifications for details).
- Colors shown are for reference only, and are subject to the limitations of the printing process and/or variance of electronic RGB screen displays. Refer to color system swatches and/or final finish samples for accurate reference.
- Messages shown here are general placeholders only. See graphic message schedules for specific messaging by location and sign type.

FABRICATION INTENT NOTES

- F1** SIGN FACE: 3/8" thick aluminum panel; paint all exposed surfaces of sign face to match P1, satin finish
- F2** TRIM: fabricated aluminum trim piece; attached to sign face panel with LORD adhesive; paint all exposed surfaces to match P2, satin finish
- F3** MOUNTING: mount 2nd surface of sign face to wall with .125" diameter threaded studs, DF tape and silicone as required

GRAPHICS / COLORS / DECORATION NOTES

- L1** Typeface: font = ClearviewText Medium
- S1** Universal Symbols: AIGA style symbol artwork
- S2** Arrow(s): use only official DFW Airport wayfinding arrow artwork
- VINYL (FILM):**
- V1** Blue: 3M EC 7725-37 Sapphire Blue
- V2** White: 3M 7725-20 Opaque Matte White
- V3** Skylink Yellow: 3M 7725-114 Enamel Receptive
- PAINT:**
- P1** Blue: Powder coated to match 3M EC 7725-37, satin finish
- P2** Silver: MAP paint # MP30136, satin finish

WARNING:

This record contains Sensitive Security Information that is controlled under 49 CFR parts 15 and 1520. No part of this record may be disclosed to persons with a "need to know," as defined in 49 CFR parts 15 and 1520, except with the written permission of the Administrator of the Transportation Security Administration or the Secretary of Transportation. Unauthorized release may result in civil penalty or other action. For U.S. government agencies, public disclosure is governed by 5 U.S.C. 552 and 49 CFR parts 15 and 1520.

ILLUMINATION	SIGN TYPE	SIGN FUNCTION	MOUNTING METHOD	GENERAL DESCRIPTION and USE
INTERNAL	1-ID.60	IDENTIFICATION	FREESTANDING	Gate ID Pylon - Freestanding

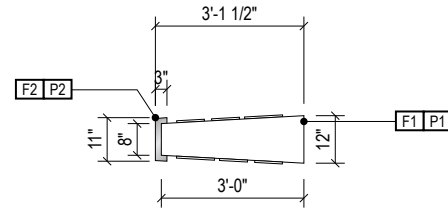

1 PLAN VIEW
Scale: 1/4" = 1'-0"

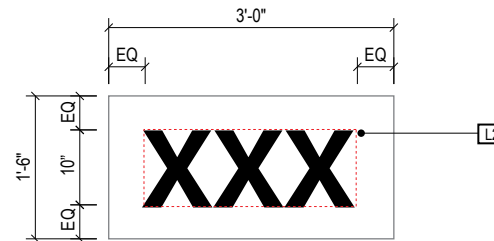

A DETAIL A: Face Layout
Scale: 1/2" = 1'-0"

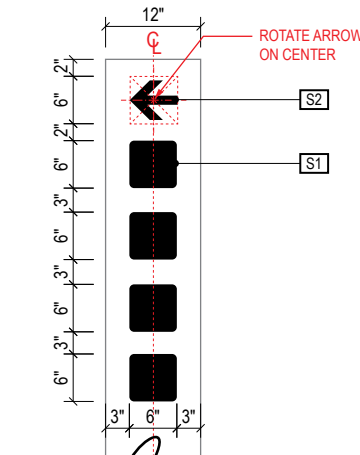

B DETAIL B: Face Layout
Scale: 1/2" = 1'-0"

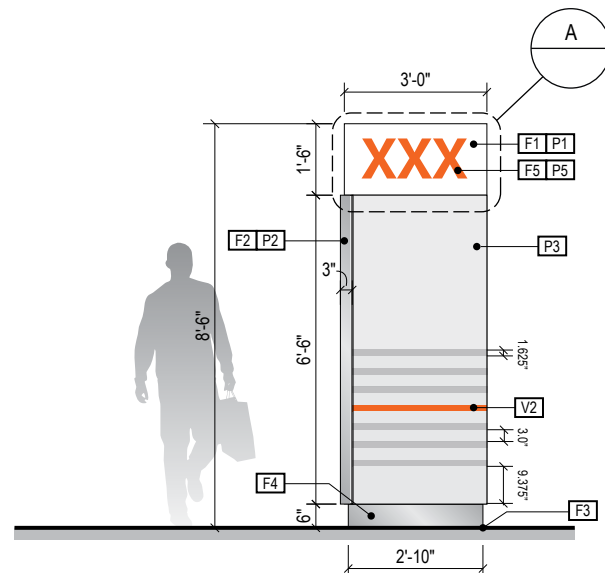

2 ELEVATION
Scale: 1/4" = 1'-0"

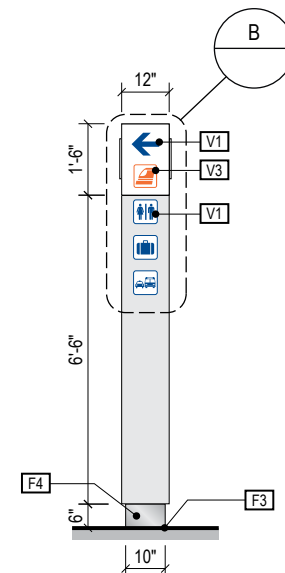

3 END VIEW
Scale: 1/4" = 1'-0"

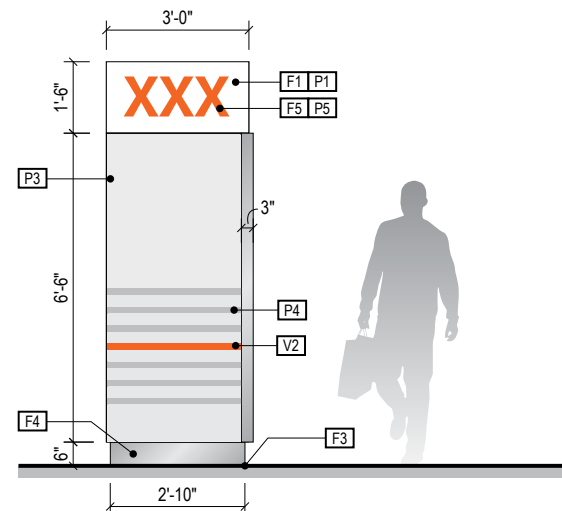

4 ELEVATION (OPPOSITE SIDE)
Scale: 1/4" = 1'-0"

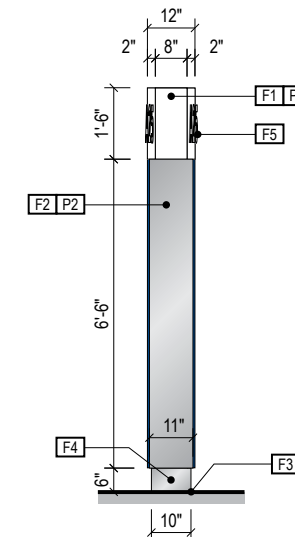

5 END VIEW
Scale: 1/4" = 1'-0"

GENERAL NOTES

- All final design, engineering, and amount/sizing of structural sign support elements, material types/thicknesses, dimensions and attachment methods shall be performed and approved by a licensed engineer to meet or exceed all applicable local and national codes.
- Final engineering, dimensions, materials, and fabrication are the responsibility of the Fabricator to ensure the highest quality fit and finish for all components of the completed product. All final detailing and specifications to be provided by the Fabricator within their final approved fabrication-ready shop drawings.
- Whenever dissimilar metals are in contact, always separate contact surfaces prior to assembly or installation with the necessary protective coatings/gaskets/washers to prevent galvanic corrosion.
- Final fabrication methods, quality and fit/finish to be reviewed and approved by DFW Planning Dept. and wayfinding/architecture Design Consultants through prototype reviews prior to final production run/installation processes (see Performance Specifications for details).
- Colors shown are for reference only, and are subject to the limitations of the printing process and/or variance of electronic RGB screen displays. Refer to color system swatches and/or final finish samples for accurate reference.
- Messages shown here are general placeholders only. See graphic message schedules for specific messaging by location and sign type.

FABRICATION INTENT NOTES

- F1** SIGN CABINET/FRAME: freestanding, fabricated aluminum sign cabinet with extruded copy; paint exposed surfaces of sign cabinet to match super white (matte). Top is painted, not coated. Apply vinyl V2 graphic where applicable.
- F2** TRIM: 0.125 fabricated alum. trim piece with closed ends; detachable and mounted with keyholes/studs and set screws; paint all exposed surfaces to match P2, clear coated finish (non-gloss)
- F3** MOUNTING: anchor to floor with connection system as installation location conditions require (Fabricator to coordinate connection location/type of structural elements with General Contractor)
- F4** INSET KICK: Stainless steel inset with #4 horizontal brushed finish.
- F5** EXTRUDED COPY: 1/4" aluminum 6061-T6 using a waterjet machine. Acute fillet angles will contain an undercut. Letters/numbers/text are 1/4" extruded from face and are applied to face with clear silicone.

GRAPHICS/COLORS/DECORATION NOTES

- L2** Typeface: font = Neue Haas Bold
 - S1** Universal Symbols: AIGA style symbol artwork
 - S2** Arrow(s): use only official DFW Airport wayfinding arrow artwork V1
 - V1** Blue Vinyl (FILM): 3M Sapphire blue, 3MEC7725-37
 - V2** Orange text and stripe: 3M #44 Orange Vinyl
 - V3** Skylink Yellow: 3M 7725-114 Enamel Receptive
- PAINT:**
- P1** White: Matthews Super White, matte finish
 - P2** Silver: MAP paint # MP30136, clear coated finish (non-gloss)
 - P3** Light Gray: Cool Gray 1c, MAP paint #MP07273, matte finish
 - P4** Medium Gray: Matthews formulated paint color to match PMS Cool Gray 4c, matte finish
 - P5** Orange: Ellis paint. Hy-Lux Extreme High Gloss Enamel 340 to match Pantone 166c, matte finish

WARNING:

This record contains Sensitive Security Information that is controlled under 49 CFR parts 15 and 1520. No part of this record may be disclosed to persons with a "need to know," as defined in 49 CFR parts 15 and 1520, except with the written permission of the Administrator of the Transportation Security Administration or the Secretary of Transportation. Unauthorized release may result in civil penalty or other action. For U.S. government agencies, public disclosure is governed by 5 U.S.C. 552 and 49 CFR parts 15 and 1520.

ILLUMINATION	SIGN TYPE	SIGN FUNCTION	MOUNTING METHOD	GENERAL DESCRIPTION & USE
NON-ILLUMINATED	1-ID.40	IDENTIFICATION	BLADE MOUNT	Secondary ID - Blade Mounted

GENERAL NOTES

- All final design, engineering, and amount/sizing of structural sign support elements, material types/thicknesses, dimensions, and attachment methods shall be performed and approved by a licensed engineer to meet or exceed all applicable local and national codes.
- Final engineering, dimensions, materials and fabrication are the responsibility of the Fabricator to ensure the highest quality fit and finish for all components of the completed product. All final detailing and specifications to be provided by the Fabricator within their final approved fabrication-ready shop drawings.
- Wherever dissimilar metals are in contact, always separate contact surfaces prior to assembly or installation with the necessary protective coatings/gaskets/washers to prevent galvanic corrosion.
- Final fabrication methods, quality, and fit/finish to be reviewed and approved by DFW Planning Dept. and wayfinding/architecture Design Consultants through prototype reviews prior to final production run/installation processes (see Performance Specifications for details).
- Colors shown are for reference only, and are subject to the limitations of the printing process and/or variance of electronic RGB screen displays. Refer to color system swatches and/or final finish samples for accurate reference.
- Messages shown here are general placeholders only. See graphic message schedules for specific messaging by location and sign type.

FABRICATION INTENT NOTES

- F1** SIGN CABINET/FRAME: Fabricated aluminum cabinet, powdercoat all exposed surfaces of sign cabinet/support frame/mounting frame to match P1; applied vinyl graphics
- F2** MOUNTING: Fabricated aluminum wall mount bracket with top channel to accept sign cabinet; countersunk screws; mount to wall structural elements with connection system as installation location conditions require (Fabricator to coordinate connection location/type of structural elements with General Contractor); paint all exposed surfaces with Matthews acrylic polyurethane (MAP), P2, satin finish

GRAPHICS / COLORS / DECORATION NOTES

- S1** Universal Symbols: AIGA style symbol artwork
- S2** Arrow(s): use only official DFW Airport wayfinding arrow artwork
- VINYL (FILM):
- V2** White: 3M 7725-20 Opaque Matte White
- PAINT:
- P1** Blue: Powder coated to match 3M EC 7725-37, satin finish
- P2** Silver: MAP paint # MP30136, satin finish

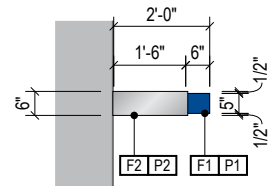

1 PLAN VIEW
Scale: 1/4" = 1'-0"

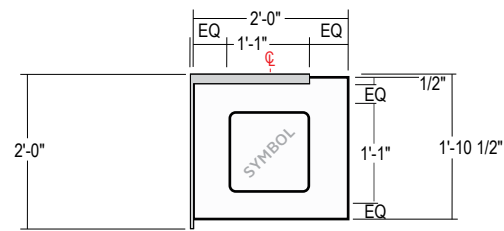

A DETAIL A: Face Layout
Scale: 1/4" = 1'-0"

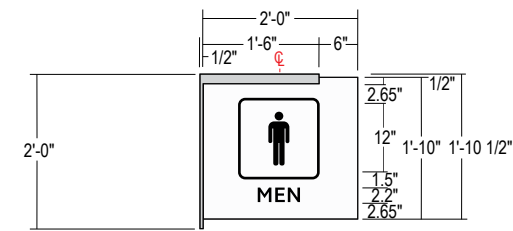

B DETAIL B: Face Layout
Scale: 1/4" = 1'-0"

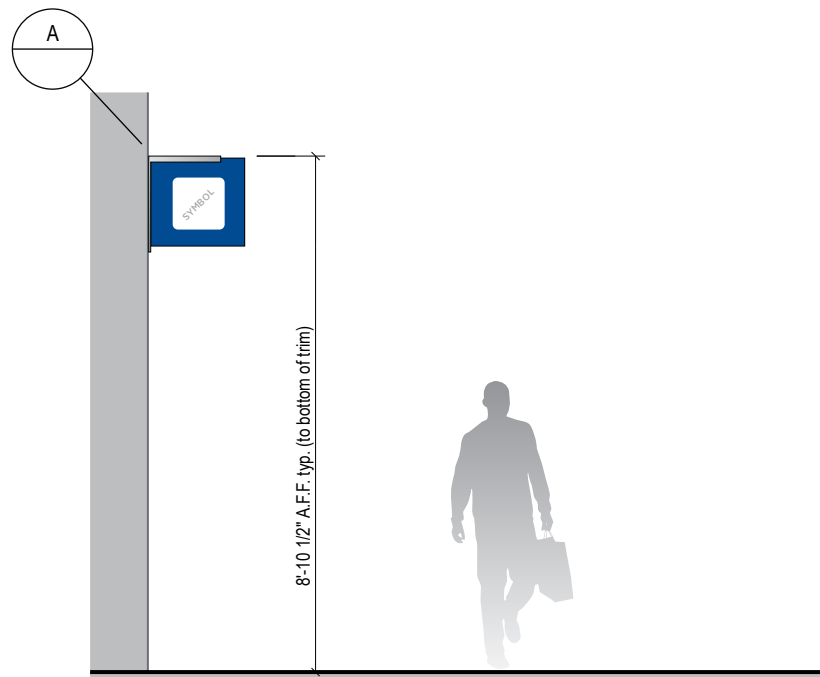

2 ELEVATION
Scale: 1/4" = 1'-0"

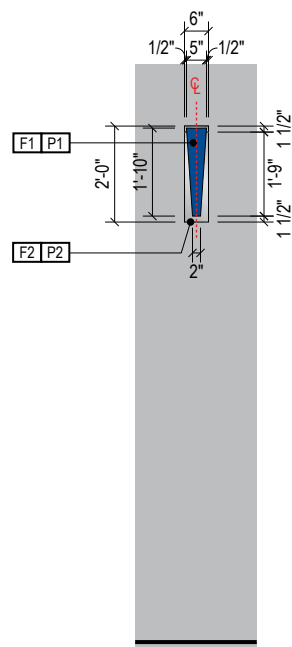

3 END VIEW
Scale: 1/4" = 1'-0"



4 ELEVATION (OPPOSITE SIDE)
Scale: 1/4" = 1'-0"

WARNING:

This record contains Sensitive Security Information that is controlled under 49 CFR parts 15 and 1520. No part of this record may be disclosed to persons with a "need to know," as defined in 49 CFR parts 15 and 1520, except with the written permission of the Administrator of the Transportation Security Administration or the Secretary of Transportation. Unauthorized release may result in civil penalty or other action. For U.S. government agencies, public disclosure is governed by 5 U.S.C. 552 and 49 CFR parts 15 and 1520.

ILLUMINATION	SIGN TYPE	SIGN FUNCTION	MOUNTING METHOD	GENERAL DESCRIPTION & USE
NON-ILLUMINATED	1-ID.02	IDENTIFICATION	SUSPENDED	Secondary ID - Suspended

GENERAL NOTES

- All final design, engineering, and amount/sizing of structural sign support elements, material types/thicknesses, dimensions and attachment methods shall be performed and approved by a licensed engineer to meet or exceed all applicable local and national codes.
- Final engineering, dimensions, materials, and fabrication are the responsibility of the Fabricator to ensure the highest quality fit and finish for all components of the completed product. All final detailing and specifications to be provided by the Fabricator within their final approved fabrication-ready shop drawings.
- Wherever dissimilar metals are in contact, always separate contact surfaces prior to assembly or installation with the necessary protective coatings/gaskets/washers to prevent galvanic corrosion.
- Final fabrication methods, quality, and fit/finish to be reviewed and approved by DFW Planning Department and wayfinding/architecture Design Consultants through prototype reviews prior to final production run/installation processes (see Performance Specifications for details).
- Colors shown are for reference only, and are subject to the limitations of the printing process and/or variance of electronic RGB screen displays. Refer to color system swatches and/or final finish samples for accurate reference.
- Messages shown here are general placeholders only. See graphic message schedules for specific messaging by location and sign type.

FABRICATION INTENT NOTES

- F1** SIGN CABINET: Fabricated aluminum cabinet, powdercoat all exposed surfaces of sign cabinet/support frame/mounting frame to match P1; applied vinyl graphics
- F2** TRIM: .080 fabricated alum. trim piece with closed ends; detachable and mounted with keyholes/studs and set screws; paint all exposed surfaces to match P2, satin finish
- F3** MOUNTING: mount to hidden above-ceiling structural elements with connection system as installation location conditions require (Fabricator to coordinate connection location/type of structural elements with General Contractor); 1" dia. alum. suspension tube supports with 4" dia. 3/16" thk alum. escutcheon cover plate at ceiling connection point, paint all exposed surfaces with Matthews acrylic polyurethane (MAP), satin finish; attached to sign support frame with weld applied flanges and mechanical fasteners

GRAPHICS / COLORS / DECORATION NOTES

- S1** Universal Symbols: AIGA style symbol artwork
- S2** Arrow(s): use only official DFW Airport wayfinding arrow artwork
- VINYL (FILM):
- V2** White: 3M 7725-20 Opaque Matte White
- PAINT:
- P1** Blue: Powder coated to match 3M EC 7725-37, satin finish
- P2** Silver: MAP paint # MP30136, satin finish

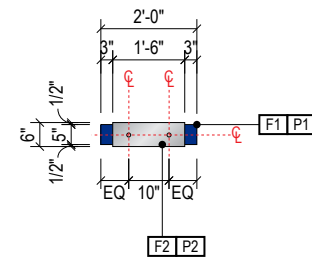

1 PLAN VIEW

Scale: 1/4" = 1'-0"

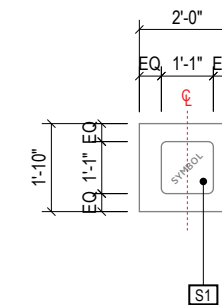

A DETAIL A: Face Layout

Scale: 1/4" = 1'-0"

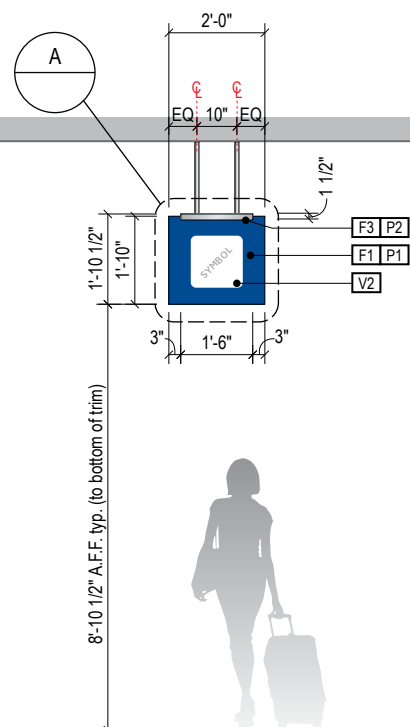

2 ELEVATION

Scale: 1/4" = 1'-0"

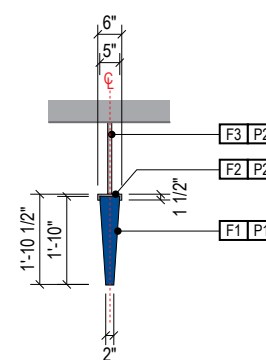

3 END VIEW

Scale: 1/4" = 1'-0"

NOTE: Attached to structural elements above ceiling

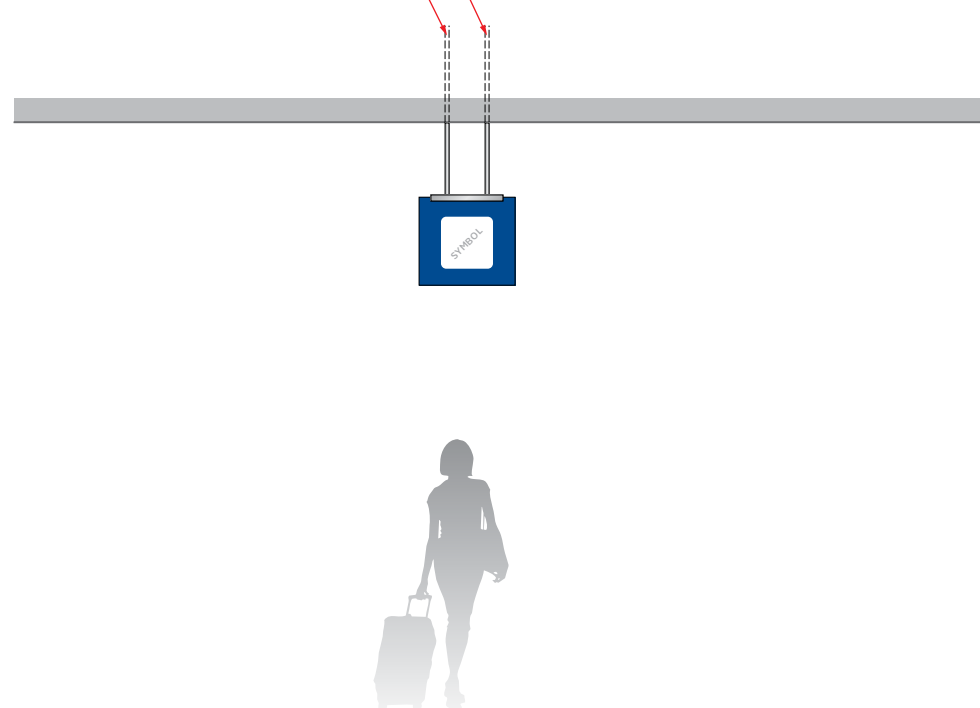

4 ELEVATION (OPPOSITE SIDE)

Scale: 1/4" = 1'-0"

WARNING:

This record contains Sensitive Security Information that is controlled under 49 CFR parts 15 and 1520. No part of this record may be disclosed to persons with a "need to know," as defined in 49 CFR parts 15 and 1520, except with the written permission of the Administrator of the Transportation Security Administration or the Secretary of Transportation. Unauthorized release may result in civil penalty or other action. For U.S. government agencies, public disclosure is governed by 5 U.S.C. 552 and 49 CFR parts 15 and 1520.

ILLUMINATION	SIGN TYPE	SIGN FUNCTION	MOUNTING METHOD	GENERAL DESCRIPTION & USE
NON-ILLUMINATED	1-ID.32	IDENTIFICATION	FASCIA MOUNT	Tertiary ID - Fascia Mounted

GENERAL NOTES

- All final design, engineering, and amount/sizing of structural sign support elements, material types/thicknesses, dimensions, and attachment methods shall be performed and approved by a licensed engineer to meet or exceed all applicable local and national codes.
- Final engineering, dimensions, materials, and fabrication are the responsibility of the Fabricator to ensure the highest quality fit and finish for all components of the completed product. All final detailing and specifications to be provided by the Fabricator within their final approved fabrication-ready shop drawings.
- Wherever dissimilar metals are in contact, always separate contact surfaces prior to assembly or installation with the necessary protective coatings/gaskets/washers to prevent galvanic corrosion.
- Final fabrication methods, quality and fit/finish to be reviewed and approved by DFW Airport Planning Department and wayfinding/architecture Design Consultants thru prototype reviews prior to final production run/installation processes (see Performance Specifications for details).
- Colors shown are for reference only, and are subject to the limitations of the printing process and/or variance of electronic RGB screen displays. Refer to color system swatches and/or final finish samples for accurate reference.
- Messages shown here are general placeholders only. See graphic message schedules for specific messaging by location and sign type.

FABRICATION INTENT NOTES

- F1** SIGN FACE: 3/8" thick alum. panel; powdercoat all exposed surfaces of sign cabinet/support frame/mounting frame to match P1, satin finish; applied vinyl graphics
- F2** TRIM: fabricated alum. trim piece; attached to sign face panel with LORD adhesive; paint all exposed surfaces to match P2, satin finish
- F3** MOUNTING: mount 2nd surface of sign face to wall with .125" diameter threaded studs, DF tape and silicone as required

GRAPHICS / COLORS / DECORATION NOTES

- S1** Universal Symbols: AIGA style symbol artwork
- S2** Arrow(s): use only official DFW Airport wayfinding arrow artwork
- VINYL (FILM):
- V2** White: 3M 7725-20 Opaque Matte White
- PAINT:
- P1** Blue: Powder coated to match 3M EC 7725-37, satin finish
- P2** Silver: MAP paint # MP30136, satin finish

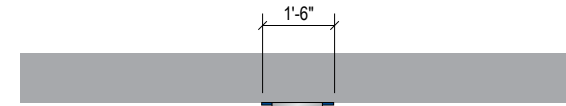

1 PLAN VIEW
Scale: 1/4" = 1'-0"

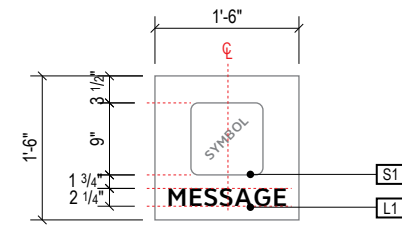

A DETAIL A: Face Layout
Scale: 1/2" = 1'-0"

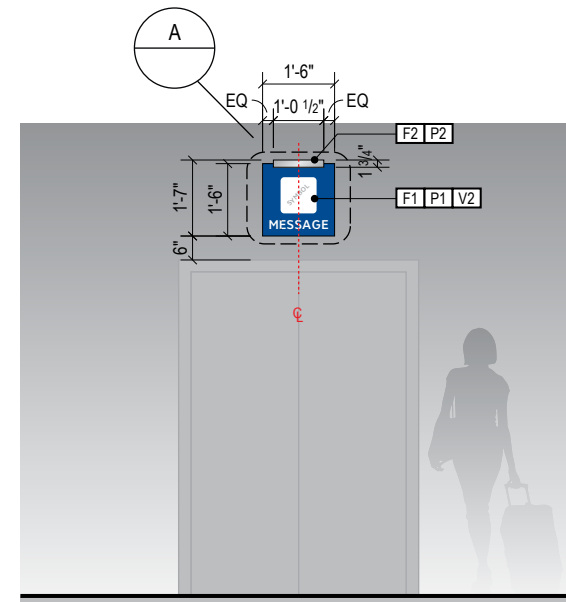

2 ELEVATION
Scale: 1/4" = 1'-0"



3 END VIEW
Scale: 1/4" = 1'-0"

WARNING:

This record contains Sensitive Security Information that is controlled under 49 CFR parts 15 and 1520. No part of this record may be disclosed to persons with a "need to know," as defined in 49 CFR parts 15 and 1520, except with the written permission of the Administrator of the Transportation Security Administration or the Secretary of Transportation. Unauthorized release may result in civil penalty or other action. For U.S. government agencies, public disclosure is governed by 5 U.S.C. 552 and 49 CFR parts 15 and 1520.

ILLUMINATION	SIGN TYPE	SIGN FUNCTION	MOUNTING METHOD	GENERAL DESCRIPTION & USE
NON-ILLUMINATED	1-ID.30 / 1-ID.31	IDENTIFICATION	WALL	Entry Toilet ID; Transition Toilet ID

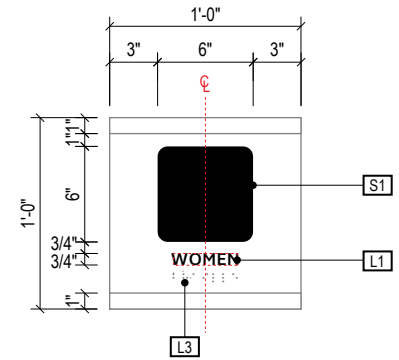

A DETAIL A: Face Layout
Scale: 1/2" = 1'-0"

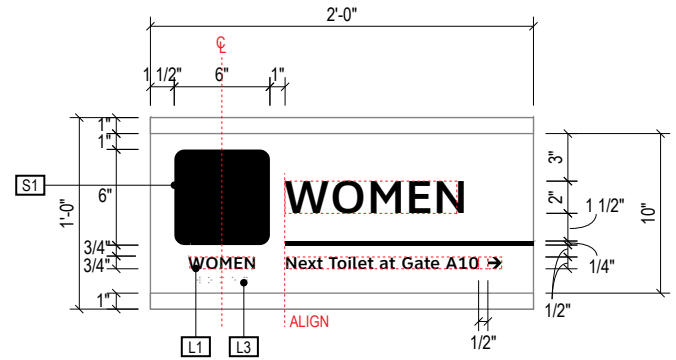

B DETAIL A: Face Layout
Scale: 1/2" = 1'-0"

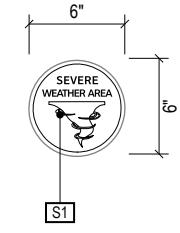

C DETAIL C: Face Layout
Scale: 1/2" = 1'-0"

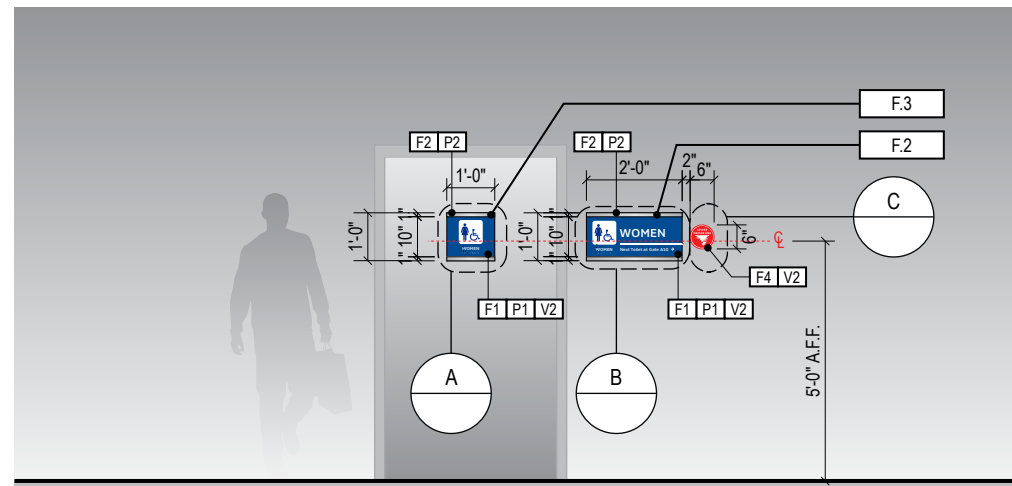

1 ELEVATION
Scale: 1/4" = 1'-0"

GENERAL NOTES

- All final design, engineering, and amount/sizing of structural sign support elements, material types/thicknesses, dimensions, and attachment methods shall be performed and approved by a licensed engineer to meet or exceed all applicable local and national codes.
- Final engineering, dimensions, materials, and fabrication are the responsibility of the Fabricator to ensure the highest quality fit and finish for all components of the completed product. All final detailing and specifications to be provided by the Fabricator within their final approved fabrication-ready shop drawings.
- Wherever dissimilar metals are in contact, always separate contact surfaces prior to assembly or installation with the necessary protective coatings/gaskets/washers to prevent galvanic corrosion.
- Final fabrication methods, quality and fit/finish to be reviewed and approved by DFW Airport Planning Department and wayfinding/architecture Design Consultants thru prototype reviews prior to final production run/installation processes (see Performance Specifications for details).
- Colors shown are for reference only, and are subject to the limitations of the printing process and/or variance of electronic RGB screen displays. Refer to color system swatches and/or final finish samples for accurate reference.
- Messages shown here are general placeholders only. See graphic message schedules for specific messaging by location and sign type.

FABRICATION INTENT NOTES

- F1** SIGN FACE: Dibond sign panel attached to aluminum tube frame; powdercoat to match P1; applied white V2 - White vinyl graphics
- F2** FRAME: 1"x1" fabricated aluminum frame; paint all exposed to match P2 - Silver
- F3** MOUNTING: mount 2nd surface of sign face to wall with .125" diameter threaded studs, DF tape and silicone as required
- F4** SEVERE WEATHER PLAQUE: locate Severe Weather plaque adjacent to restroom sign

GRAPHICS / COLORS / DECORATION NOTES

- L1** Typeface: font = ClearviewText Medium
- L2** Typeface: font = ClearviewText Bold
- L3** BRAILLE: Grade 2 contracted Braille; must meet all applicable ADA/TAS requirements for tactile signage
- S1** Universal Symbols: AIGA style symbol artwork
- S2** Arrow(s): use only official DFW Airport wayfinding arrow artwork
- VINYL (FILM):**
- V1** Blue: 3M EC 7725-37 Sapphire Blue
- V2** White: 3M 7725-20 Opaque Matte White
- V3** Skylink Yellow: 3M 7725-114 Enamel Receptive
- V4** Exit Light Green: 3M Opaque Matte to match PMS 368C
- V5** Black: 3M 7725-22 Opaque Matte Black
- V6** Safety Red: 3M Opaque Matte to match PMS 485C
- PAINT:**
- P1** Blue: Powder coated to match 3M EC 7725-37, satin finish
- P2** Silver: MAP paint # MP30136, satin finish
- P3** Skylink Yellow: MAP paint to match PMS 130C, satin finish
- P4** White: MAP paint # MP05317; photopolymer Braille, satin fin.
- P5** Light Green: MAP Paint to match PMS 368C, satin finish

ILLUMINATION	SIGN TYPE	SIGN FUNCTION	MOUNTING METHOD	GENERAL DESCRIPTION & USE
NON-ILLUMINATED	1-ID.20	IDENTIFICATION	FASCIA MOUNT	Gate Door ID - Fascia Mounted

GENERAL NOTES

- All final design, engineering, and amount/sizing of structural sign support elements, material types/thicknesses, dimensions, and attachment methods shall be performed and approved by a licensed engineer to meet or exceed all applicable local and national codes.
- Final engineering, dimensions, materials, and fabrication are the responsibility of the Fabricator to ensure the highest quality fit and finish for all components of the completed product. All final detailing and specifications to be provided by the Fabricator within their final approved fabrication-ready shop drawings.
- Wherever dissimilar metals are in contact, always separate contact surfaces prior to assembly or installation with the necessary protective coatings/gaskets/washers to prevent galvanic corrosion.
- Final fabrication methods, quality and fit/finish to be reviewed and approved by DFW Airport Planning Department and wayfinding/architecture Design Consultants thru prototype reviews prior to final production run/installation processes (see Performance Specifications for details).
- Colors shown are for reference only, and are subject to the limitations of the printing process and/or variance of electronic RGB screen displays. Refer to color system swatches and/or final finish samples for accurate reference.
- Messages shown here are general placeholders only. See graphic message schedules for specific messaging by location and sign type.

FABRICATION INTENT NOTES

- F1** SIGN FACE: 3/8" thick aluminum panel; powdercoat all exposed surfaces of sign cabinet/support frame/mounting frame to match P1, satin finish; applied vinyl graphics
- F3** MOUNTING: mount 2nd surface of sign face to wall with .125" diameter threaded studs, DF tape and silicone as required

GRAPHICS / COLORS / DECORATION NOTES

- L2** Typeface: font = ClearviewText Bold
- VINYL (FILM):
- V2** White: 3M 7725-20 Opaque Matte White=
- PAINT:
- P1** Blue: Powder coated to match 3M EC 7725-37, satin finish

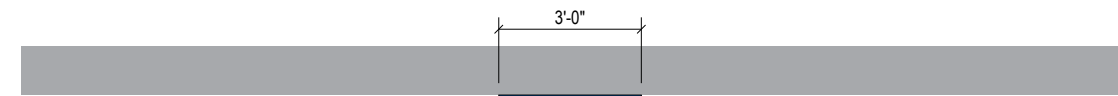

1 PLAN VIEW
Scale: 1/4" = 1'-0"

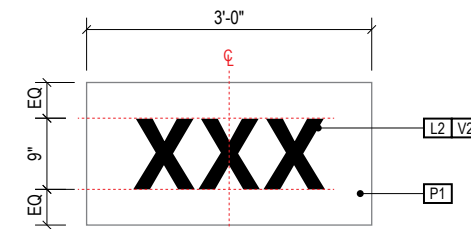

A DETAIL A: Face Layout
Scale: 1/2" = 1'-0"

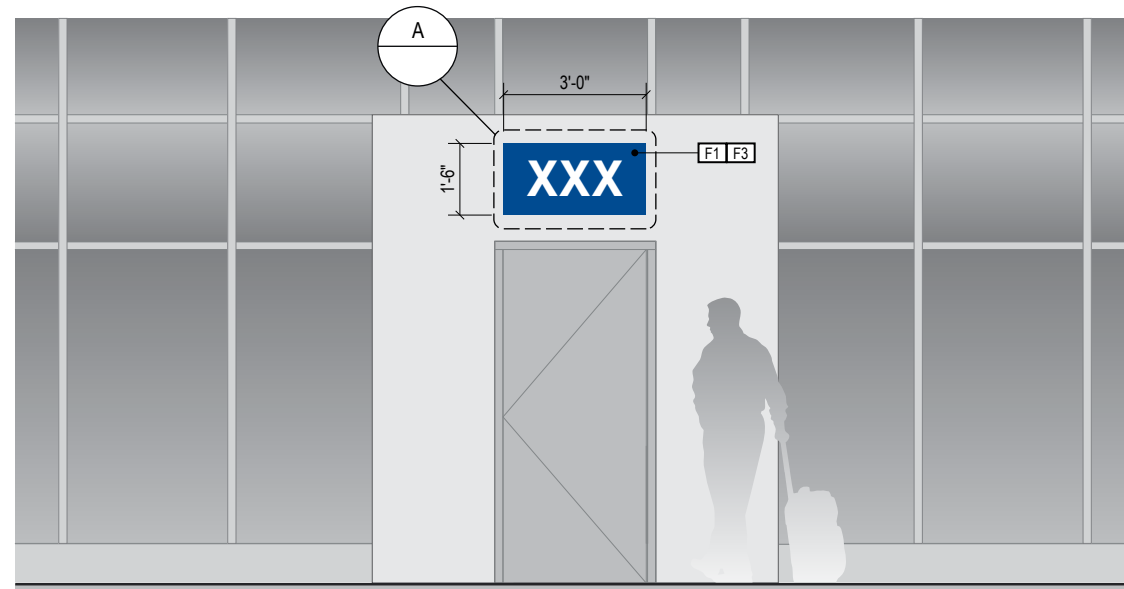

2 ELEVATION
Scale: 1/4" = 1'-0"



3 END VIEW
Scale: 1/4" = 1'-0"

WARNING:

This record contains Sensitive Security Information that is controlled under 49 CFR parts 15 and 1520. No part of this record may be disclosed to persons with a "need to know," as defined in 49 CFR parts 15 and 1520, except with the written permission of the Administrator of the Transportation Security Administration or the Secretary of Transportation. Unauthorized release may result in civil penalty or other action. For U.S. government agencies, public disclosure is governed by 5 U.S.C. 552 and 49 CFR parts 15 and 1520.

ILLUMINATION	SIGN TYPE	SIGN FUNCTION	MOUNTING METHOD	GENERAL DESCRIPTION & USE
INTERNAL	1-ID.01	IDENTIFICATION	CEILING MOUNT	Bag Claim ID

GENERAL NOTES

- All final design, engineering, and amount/sizing of structural sign support elements, material types/thicknesses, dimensions, and attachment methods shall be performed and approved by a licensed engineer to meet or exceed all applicable local and national codes.
- Final engineering, dimensions, materials, and fabrication are the responsibility of the Fabricator to ensure the highest quality fit and finish for all components of the completed product. All final detailing and specifications to be provided by the Fabricator within their final approved fabrication-ready shop drawings.
- Wherever dissimilar metals are in contact, always separate contact surfaces prior to assembly or installation with the necessary protective coatings/gaskets/washers to prevent galvanic corrosion.
- Final fabrication methods, quality and fit/finish to be reviewed and approved by DFW Airport Planning Department and wayfinding/architecture Design Consultants thru prototype reviews prior to final production run/installation processes (see Performance Specifications for details).
- Colors shown are for reference only, and are subject to the limitations of the printing process and/or variance of electronic RGB screen displays. Refer to color system swatches and/or final finish samples for accurate reference.
- Messages shown here are general placeholders only. See graphic message schedules for specific messaging by location and sign type.

FABRICATION INTENT NOTES

- F1** SIGN CABINET/FRAME: .080" fabricated aluminum cabinet with internally illuminated push-thru acrylic copy; powdercoat all exposed surfaces of sign cabinet/support frame/mounting frame to match P1, satin finish
- F2** MOUNTING: Fabricated .080" aluminum ceiling mount bracket; mount to hidden above-ceiling structural elements with connection system as installation location conditions require (Fabricator to coordinate connection location/type of structural elements with General Contractor); paint all exposed surfaces with Matthews acrylic polyurethane (MAP), P2, satin finish
- F3** PUSH-THRU COPY: 1/2" translucent white acrylic mounted with studs and clear silicone

GRAPHICS / COLORS / DECORATION NOTES

- L2** Typeface: font = ClearviewText Bold
 - S1** Universal Symbols: AIGA style symbol artwork
- PAINT:
- P1** Blue: Powder coated to match 3M EC 7725-37, satin finish
 - P2** Silver: MAP paint # MP30136, satin finish

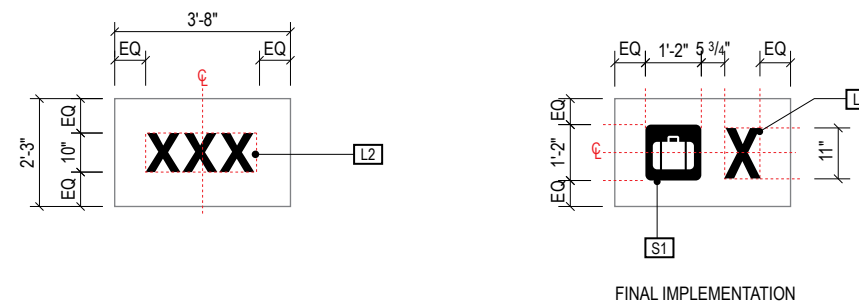
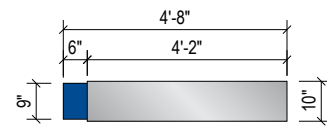

1 PLAN VIEW
Scale: 1/4" = 1'-0"

A DETAIL: Face Layout
Scale: 1/4" = 1'-0"

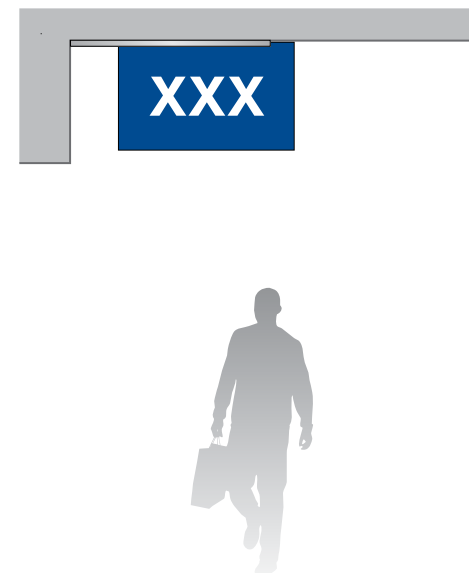
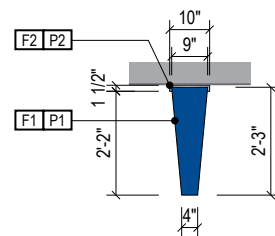
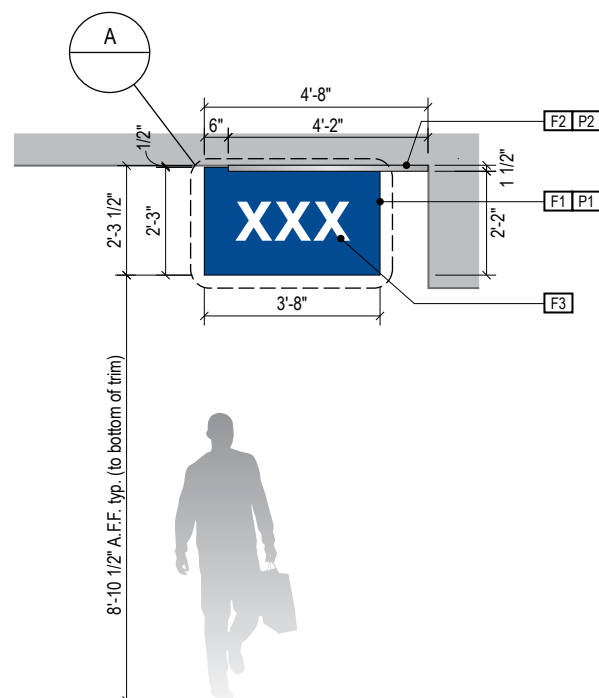

2 ELEVATION
Scale: 1/4" = 1'-0"

3 END VIEW
Scale: 1/4" = 1'-0"

4 ELEVATION (OPPOSITE SIDE)
Scale: 1/4" = 1'-0"

WARNING:

This record contains Sensitive Security Information that is controlled under 49 CFR parts 15 and 1520. No part of this record may be disclosed to persons with a "need to know," as defined in 49 CFR parts 15 and 1520, except with the written permission of the Administrator of the Transportation Security Administration or the Secretary of Transportation. Unauthorized release may result in civil penalty or other action. For U.S. government agencies, public disclosure is governed by 5 U.S.C. 552 and 49 CFR parts 15 and 1520.

ILLUMINATION	SIGN TYPE	SIGN FUNCTION	MOUNTING METHOD	GENERAL DESCRIPTION & USE
NON-ILLUMINATED	1-ID.21	INFORMATIONAL	WALL MOUNT	Courtesy Phone - Wall Mounted

GENERAL NOTES

- All final design, engineering, and amount/sizing of structural sign support elements, material types/thicknesses, dimensions, and attachment methods shall be performed and approved by a licensed engineer to meet or exceed all applicable local and national codes.
- Final engineering, dimensions, materials, and fabrication are the responsibility of the Fabricator to ensure the highest quality fit and finish for all components of the completed product. All final detailing and specifications to be provided by the Fabricator within their final approved fabrication-ready shop drawings.
- Wherever dissimilar metals are in contact, always separate contact surfaces prior to assembly or installation with the necessary protective coatings/gaskets/washers to prevent galvanic corrosion.
- Final fabrication methods, quality and fit/finish to be reviewed and approved by DFW Airport Planning Department and wayfinding/architecture Design Consultants thru prototype reviews prior to final production run/installation processes (see Performance Specifications for details).
- Colors shown are for reference only, and are subject to the limitations of the printing process and/or variance of electronic RGB screen displays. Refer to color system swatches and/or final finish samples for accurate reference.
- Messages shown here are general placeholders only. See graphic message schedules for specific messaging by location and sign type.

FABRICATION INTENT NOTES

- F1 SIGN FACE:**
- Face Panel: 1/8" clear non-glare acrylic
 - Graphic Insert: separate 3mm PVC with printed vinyl overlay graphic
 - Header: 3mm PVC with applied graphic overlay and brushed alum. film stripe
 - Spacer: 3mm solid PVC panel
 - Backing: 1/2" solid MDO board
- NOTE: cut-out opening for phone location thru all layers
- F2 FRAME:** fabricated 1" x 1" x 1/8" aluminum angle; paint all exposed surfaces to match P2, satin finish
- F3 MOUNTING:** mount alum. angle frame to wall with hidden mechanical fasteners as conditions require; mount all sign face layers/components at corners (as shown) into MDO backer panel using 3/16" screws with threaded T-nuts.

GRAPHICS / COLORS / DECORATION NOTES

- L1** Typeface: font = ClearviewText Medium
L2 Typeface: font = ClearviewText Bold
L3 BRAILLE: Grade 2 contracted Braille; must meet all applicable ADA/TAS requirements for tactile signage
S1 Universal Symbols: AIGA style symbol artwork
S2 Arrow(s): use only official DFW Airport wayfinding arrow artwork
VINYL (FILM):
V1 Blue: 3M EC 7725-37 Sapphire Blue
V2 White: 3M 7725-20 Opaque Matte White
V3 Skylink Yellow: 3M 7725-114 Enamel Receptive
V4 Exit Light Green: 3M Opaque Matte to match PMS 368C
V5 Black: 3M 7725-22 Opaque Matte Black
V6 Safety Red: 3M Opaque Matte to match PMS 485C
PAINT:
P1 Blue: Powder coated to match 3M EC 7725-37, satin finish
P2 Silver: MAP paint # MP30136, satin finish
P3 Skylink Yellow: MAP paint to match PMS 130C, satin finish
P4 White: MAP paint # MP05317; photopolymer Braille, satin fin.
P5 Light Green: MAP Paint to match PMS 368C, satin finish

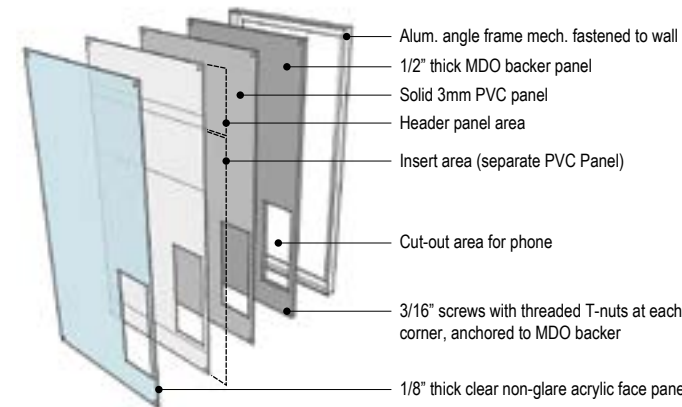

2 PERSPECTIVE (EXPLODED VIEW)

Scale: NTS

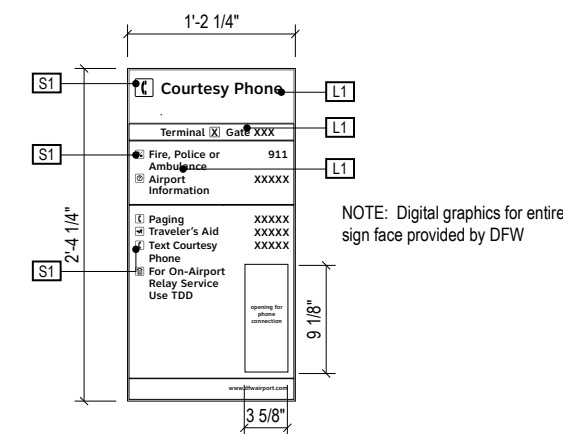

A DETAIL A: Face Layout

Scale: 3/4" = 1'-0"

NOTE: Digital graphics for entire sign face provided by DFW

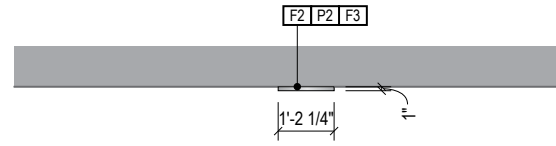

1 PLAN VIEW

Scale: 1/4" = 1'-0"

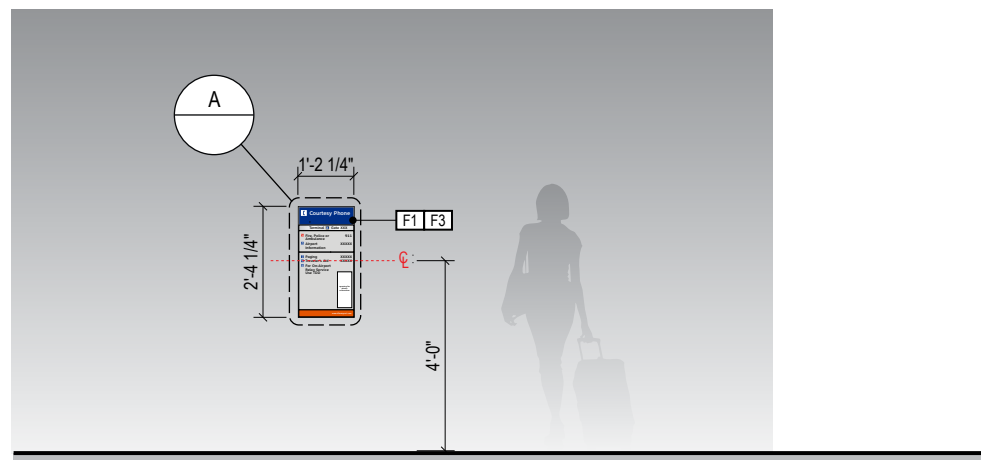

3 ELEVATION

Scale: 1/4" = 1'-0"

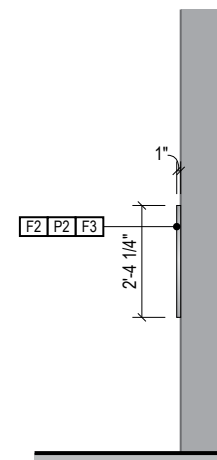

4 END VIEW

Scale: 1/4" = 1'-0"

WARNING:

This record contains Sensitive Security Information that is controlled under 49 CFR parts 15 and 1520. No part of this record may be disclosed to persons with a "need to know," as defined in 49 CFR parts 15 and 1520, except with the written permission of the Administrator of the Transportation Security Administration or the Secretary of Transportation. Unauthorized release may result in civil penalty or other action. For U.S. government agencies, public disclosure is governed by 5 U.S.C. 552 and 49 CFR parts 15 and 1520.

ILLUMINATION	SIGN TYPE	SIGN FUNCTION	MOUNTING METHOD	GENERAL DESCRIPTION & USE
NON-ILLUMINATED	1-ID.22	INFORMATIONAL	WALL MOUNT	Ground Transportation Phone - Wall Mounted

GENERAL NOTES

- All final design, engineering, and amount/sizing of structural sign support elements, material types/thicknesses, dimensions, and attachment methods shall be performed and approved by a licensed engineer to meet or exceed all applicable local and national codes.
- Final engineering, dimensions, materials, and fabrication are the responsibility of the Fabricator to ensure the highest quality fit and finish for all components of the completed product. All final detailing and specifications to be provided by the Fabricator within their final approved fabrication-ready shop drawings.
- Wherever dissimilar metals are in contact, always separate contact surfaces prior to assembly or installation with the necessary protective coatings/gaskets/washers to prevent galvanic corrosion.
- Final fabrication methods, quality and fit/finish to be reviewed and approved by DFW Airport Planning Department and wayfinding/architecture Design Consultants thru prototype reviews prior to final production run/installation processes (see Performance Specifications for details).
- Colors shown are for reference only, and are subject to the limitations of the printing process and/or variance of electronic RGB screen displays. Refer to color system swatches and/or final finish samples for accurate reference.
- Messages shown here are general placeholders only. See graphic message schedules for specific messaging by location and sign type.

FABRICATION INTENT NOTES

- F1** SIGN FACE:
- Face Panel: 1/8" clear non-glare acrylic
 - Graphic Insert: separate 3mm PVC with printed vinyl overlay graphic
 - Header: 3mm PVC with applied graphic overlay and brushed alum. film stripe
 - Spacer: 3mm solid PVC panel
 - Backing: 1/2" solid MDO board
- NOTE: cut-out opening for phone location thru all layers
- F2** FRAME: fabricated 1" x 1" x 1/8" aluminum angle; paint all exposed surfaces to match P2, satin finish
- F3** MOUNTING: mount alum. angle frame to wall with hidden mechanical fasteners as conditions require; mount all sign face layers/components at corners (as shown) into MDO backer panel using 3/16" screws with threaded T-nuts.

GRAPHICS / COLORS / DECORATION NOTES

- L1** Typeface: font = ClearviewText Medium
- L2** Typeface: font = ClearviewText Bold
- L3** BRAILLE: Grade 2 contracted Braille; must meet all applicable ADA/TAS requirements for tactile signage
- S1** Universal Symbols: AIGA style symbol artwork
- S2** Arrow(s): use only official DFW Airport wayfinding arrow artwork
- VINYL (FILM):
- V1** Blue: 3M EC 7725-37 Sapphire Blue
- V2** White: 3M 7725-20 Opaque Matte White
- V3** Skylink Yellow: 3M 7725-114 Enamel Receptive
- V4** Exit Light Green: 3M Opaque Matte to match PMS 368C
- V5** Black: 3M 7725-22 Opaque Matte Black
- V6** Safety Red: 3M Opaque Matte to match PMS 485C
- PAINT:
- P1** Blue: Powder coated to match 3M EC 7725-37, satin finish
- P2** Silver: MAP paint # MP30136, satin finish
- P3** Skylink Yellow: MAP paint to match PMS 130C, satin finish
- P4** White: MAP paint # MP05317; photopolymer Braille, satin fin.
- P5** Light Green: MAP Paint to match PMS 368C, satin finish

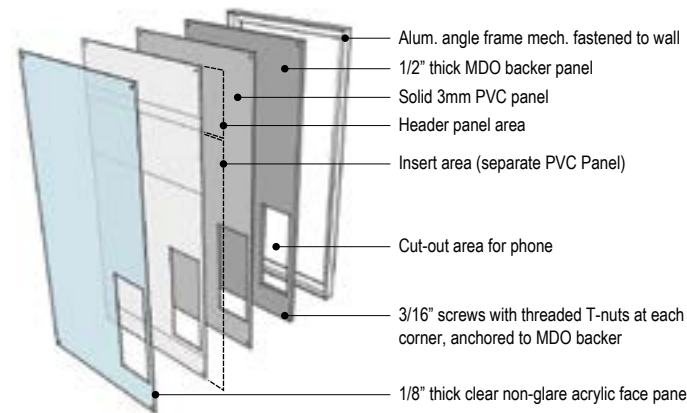

2 PERSPECTIVE (EXPLODED VIEW)

Scale: NTS

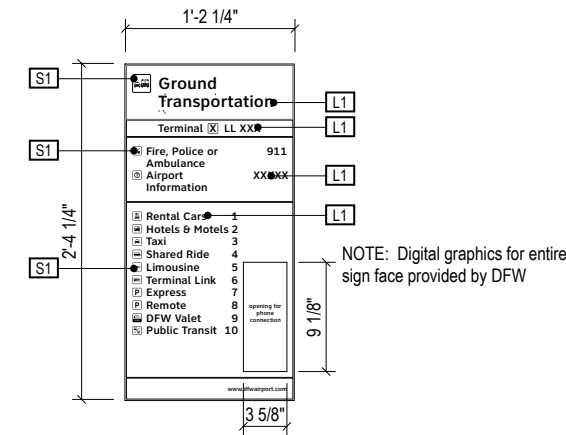

A DETAIL A: Face Layout

Scale: 3/4" = 1'-0"

NOTE: Digital graphics for entire sign face provided by DFW

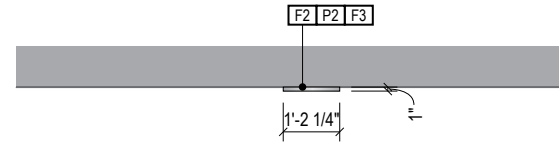

1 PLAN VIEW

Scale: 1/4" = 1'-0"

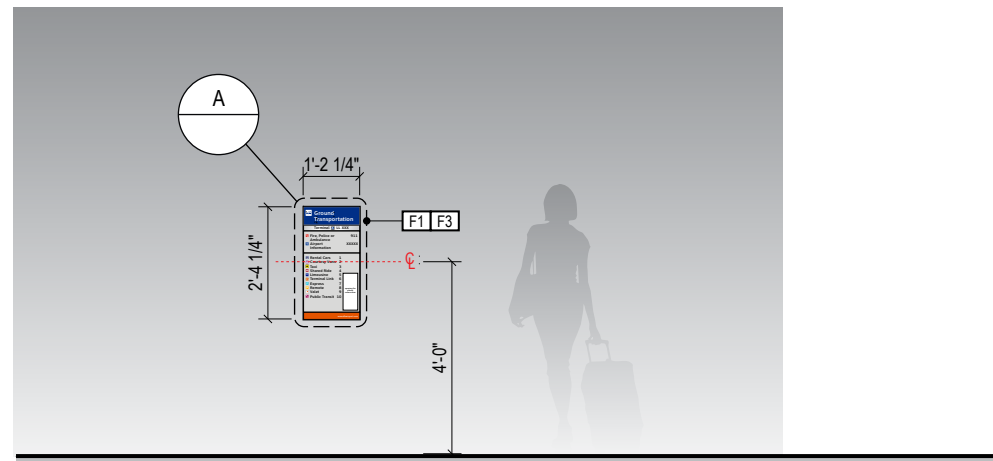

3 ELEVATION

Scale: 1/4" = 1'-0"

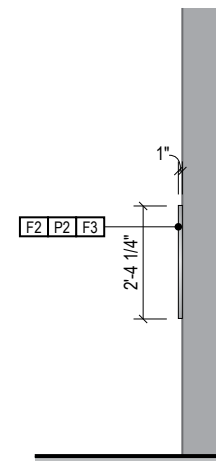

4 END VIEW

Scale: 1/4" = 1'-0"

WARNING:

This record contains Sensitive Security Information that is controlled under 49 CFR parts 15 and 1520. No part of this record may be disclosed to persons with a "need to know," as defined in 49 CFR parts 15 and 1520, except with the written permission of the Administrator of the Transportation Security Administration or the Secretary of Transportation. Unauthorized release may result in civil penalty or other action. For U.S. government agencies, public disclosure is governed by 5 U.S.C. 552 and 49 CFR parts 15 and 1520.

4.0

4.0 SIGN TYPES - CURBSIDE/GROUND TRANSPORTATION AREAS

- 4.1 Sign Type Index
- 4.2 Sign Types

SIGN TYPE INDEX - CURBSIDE/GROUND TRANSPORTATION

This chapter provides specific information regarding the wayfinding sign types applicable for use in the Curbside/Ground Transportation areas of DFW. It contains a general sign family overview of the specific sign types (i.e., the Sign Type Index section), as well as more specific design/layouts/notes/etc for each individual sign type (i.e., the Sign Types section).

On the following pages, the Sign Type Index shows sample views of each sign type, as well as listings for each sign type's name, mounting method and basic overall size. The Sign Type Index is intended only as a brief, simple catalog for all of the wayfinding sign types used within the Curbside/Ground Transportation areas of DFW, and is organized in numeric order of their sign type identification numbers (i.e. Directional sign type category: 3-DR.01, 3-DR.02, etc; Identification sign type category: 3-ID.01, 3-ID.02, etc; Informational sign type category: 3-IN.01, 3-IN.02, etc).

Sign Types - Design Intent Drawings

Section 4.2- Sign Types contains *design intent drawings of each specific wayfinding sign type used within the Curbside/Ground Transportation areas of DFW. Each sheet displays scaled drawings of individual sign types and their basic views (i.e., elevations, plan views, end view, etc), sizing/dimensions, face layouts and general design intent related notes.

**NOTE: these documents are intended to illustrate design intent, and should only be used as a general guideline. No information contained here should be construed as engineered elements. The designer/fabricator/contractor shall be responsible for all engineering and specifications with regard to structural, electrical, mechanical, foundation and installation. Details and information contained in this document shall not be reproduced, copied or utilized in any way except for the specific project for which they were created without previous written authorization from DFW.*

Mounting Requirements

Sign mountings shall support signs for optimum visibility, facilitate illumination where required, be fabricated from commonly available materials, be easily maintained, be engineered to established DFW wayfinding system and engineering requirements, and not obstruct or pose any hazard to pedestrians, vehicles or any other entity.

Basic Mounting Types

The basic mounting types used within DFW's Curbside/Ground Transportation areas are as follows:

- Ceiling Mount:
 - Suspended: overhead signs located in high ceiling areas mounted with a suspension system mechanically attached to the sign's top most element and at the top of the suspension system, with the overall suspension system/sign attached to an above-ceiling structural support system
 - Flush Top: overhead signs mounted in lower ceiling areas with the sign's top most element flush to the ceiling using a mechanical fastening system attached to an above-ceiling structural support system
- Canopy Mount:
 - Flush Top - overhead signs mounted in curbside areas with the sign's top most element flush to the underside/ceiling of a canopy and attached using a mechanical fastening system
- Wall/Soffit Mount: signs that are located on a vertical architectural fascia (overhead) or wall (overhead or pedestrian eye-level), and mechanically attached to the fascia/wall's internal vertical structure.
- Flag (Blade) Mount: overhead signs mechanically attached on one vertical edge to internal structural elements of vertical architectural surfaces (i.e. walls, columns, etc) in a "flagged" configuration
- Floor/Ground Mount: non-moveable signs mechanically attached directly to structural elements of an architectural floor or in-ground structural mounting methods
- Freestanding (Moveable): signs that utilize freestanding, non-attached base configurations, typically with wide and weighted footer features (to eliminate accidental tipping over); allow for flexibility in moving a sign as changing location conditions require
- Wall Mount - ADA/tactile plaques: signs with tactile features that are mounted to walls, doors or other required elements to meet local/ADA accessibility requirements and codes for accessible design and use

General Mounting Requirements/Restrictions - Pedestrian Signs

- All overhead pedestrian signs shall be mounted at a minimum of 8'-0" to a typical maximum of 9'-0" above finished floor to the bottom of the lowest element of the sign, unless otherwise indicated
- ADA accessibility and code required signage shall be mounted in accordance with all applicable code requirements using the most recent edition of the codes and regulations
- Whenever there is a conflict between a requirement listed in this document and another authoritative code or standard, the more stringent one shall be applied

WARNING:

This record contains Sensitive Security Information that is controlled under 49 CFR parts 15 and 1520. No part of this record may be disclosed to persons with a "need to know," as defined in 49 CFR parts 15 and 1520, except with the written permission of the Administrator of the Transportation Security Administration or the Secretary of Transportation. Unauthorized release may result in civil penalty or other action. For U.S. government agencies, public disclosure is governed by 5 U.S.C. 552 and 49 CFR parts 15 and 1520.

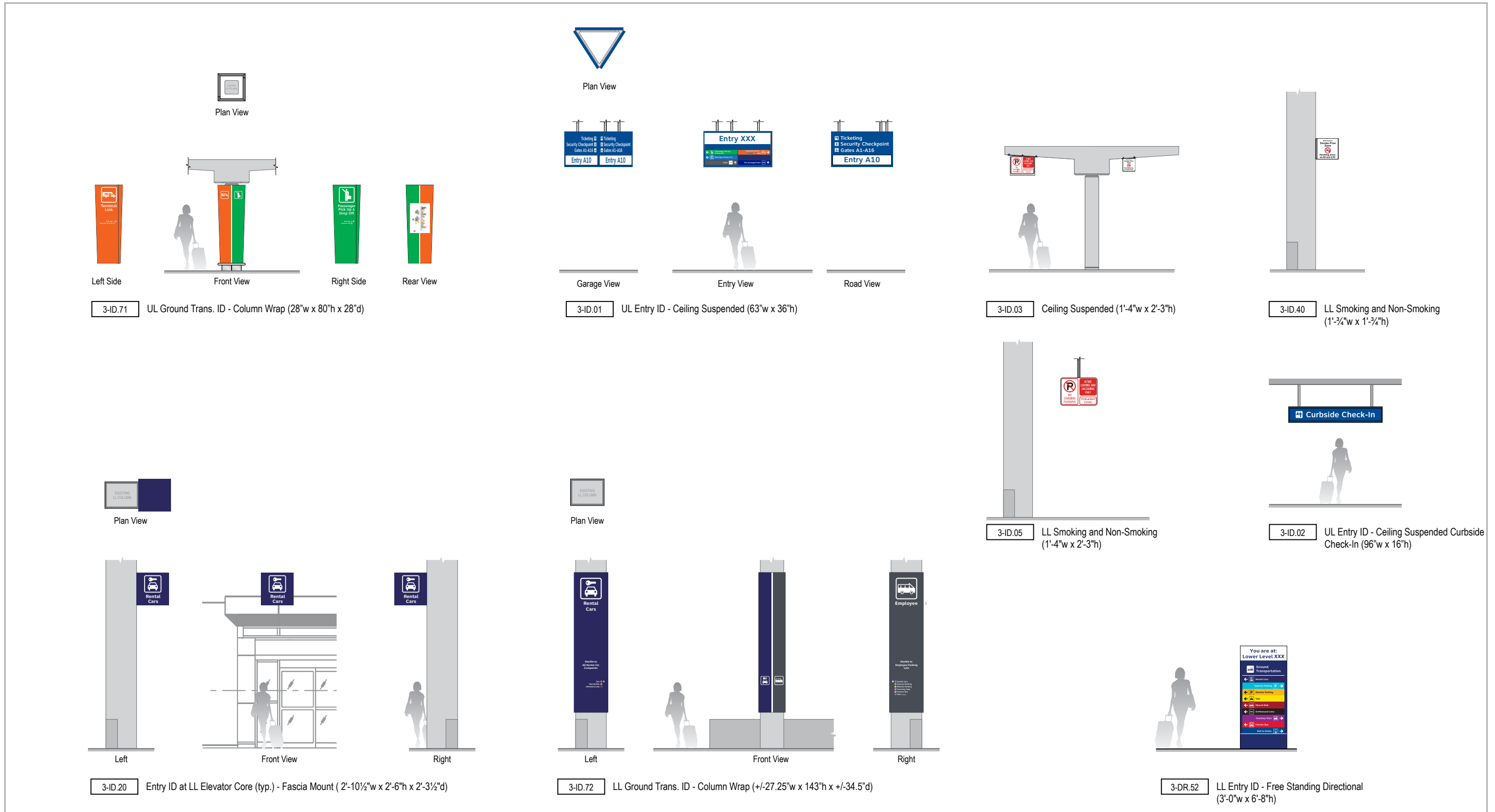
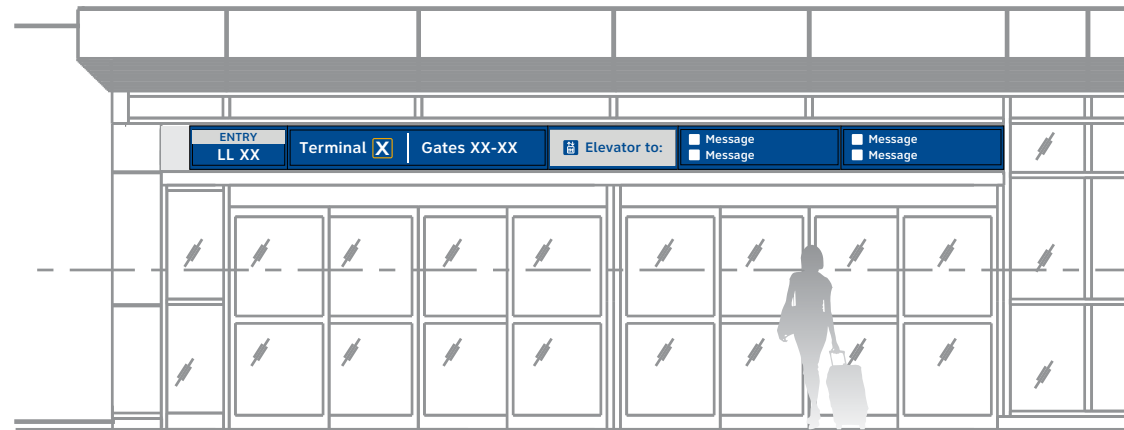

Figure 1.1.8c

DFW Wayfinding Sign Family: **Curbside/Ground Transportation Areas**



3-ID.20 Entry ID at LL Elevator Core (typ.) - Fascia Mount (228"w x 16"h)



H.3 Entry ID at LL: variant w/ Elevator/Escalator Trailblazer - Fascia Mount (228"w x 16"h)

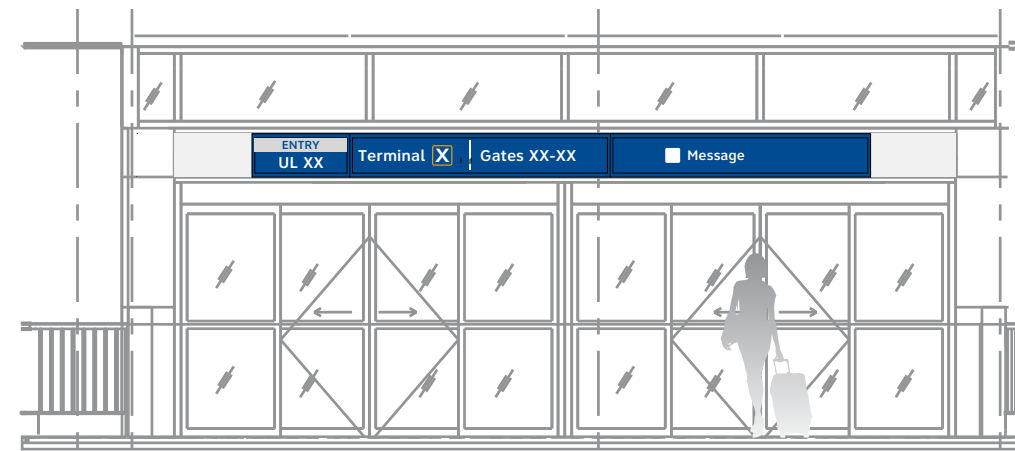

3-ID.21 Entry ID at UL Doors (typ.) - Fascia Mount (228"w x 16"h)

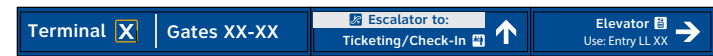

3-ID.21b Entry ID at LL: variant w/ Elevator/Escalator Trailblazer - Fascia Mount (228"w x 16"h)



3-ID.21c Entry ID: variant used at Terminal D - Fascia Mount (228"w x 16"h)

Figure 1.1.8c (cont.)

DFW Wayfinding Sign Family: **Curbside/Ground Transportation Areas**

ILLUMINATION	SIGN TYPE	SIGN FUNCTION	MOUNTING METHOD	GENERAL DESCRIPTION & USE
REFLECTIVE	3-DR.52	DIRECTIONAL / ID	Ground Mount	Lower Level Free Standing Directional/Entry ID

GENERAL NOTES

- All final design, engineering, and amount/sizing of structural sign support elements, material types/thicknesses, dimensions, and attachment methods shall be performed and approved by a licensed engineer to meet or exceed all applicable local and national codes.
- Final engineering, dimensions, materials, and fabrication are the responsibility of the Fabricator to ensure the highest quality fit and finish for all components of the completed product. All final detailing and specifications to be provided by the Fabricator within their final approved fabrication-ready shop drawings.
- Wherever dissimilar metals are in contact, always separate contact surfaces prior to assembly or installation with the necessary protective coatings/gaskets/washers to prevent galvanic corrosion.
- Final fabrication methods, quality and fit/finish to be reviewed and approved by DFW Airport Planning Department and wayfinding/architecture Design Consultants thru prototype reviews prior to final production run/installation processes (see Performance Specifications for details).
- Colors shown are for reference only, and are subject to the limitations of the printing process and/or variance of electronic RGB screen displays. Refer to color system swatches and/or final finish samples for accurate reference.
- Messages shown here are general placeholders only. See graphic message schedules for specific messaging by location and sign type.

FABRICATION INTENT NOTES

- F1** SIGN CABINET/FRAME: modular fabricated internal illuminated edge-lit sign module cabinet constructed of extruded aluminum and cast aluminum components with concealed internal welds; removable sign face and light modules; fabricated aluminum support frame with welded mitered corners and slotted mounting holes to accept sign mounting brackets; fabricated aluminum sign mounting frame with tapered side end cover panels, attached with aluminum pin and clip system; power feed/units hidden behind mounting frame with access holes in back for wall mounting; powdercoat all exposed surfaces of sign cabinet/support frame/mounting frame to match P1, satin finish
- F2** SIGN FACE: fabricated sign face assembly module constructed of extruded aluminum frame and concealed internal welds; faces are 3/16" white acrylic with 1st surface applied V1 vinyl film, graphics reversed out of blue (white is exposed white acrylic cut-thru blue film); faces illuminated with light panel assembly using LED edge-lit clear inscribed acrylic diffuser and self-contained technology (including electronics, extruded frame and diffuser)
- F3** TRIM: .080 fabricated aluminum trim piece with closed ends; detachable and mounted with keyholes/studs and set screws; paint all exposed surfaces to match P2, satin finish
- F4** MOUNTING: mount to wall structural elements with connection system as installation location conditions require (Fabricator to coordinate connection location/type of structural elements with General Contractor); paint all exposed surfaces to match P1, satin finish

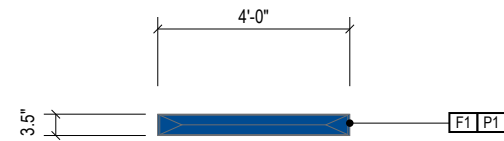

1 PLAN VIEW

Scale: 1/4" = 1'-0"

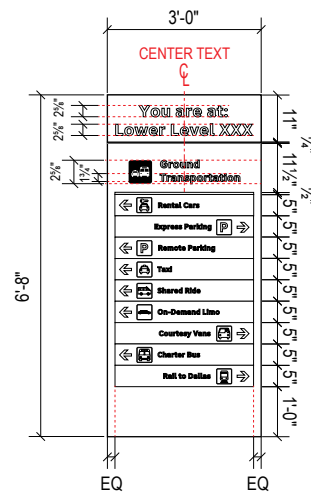

A DETAIL A: Face Layout

Scale: 1/4" = 1'-0"

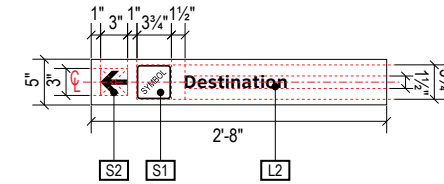

B DETAIL B: Allocation Face Layout

Scale: 1/2" = 1'-0"

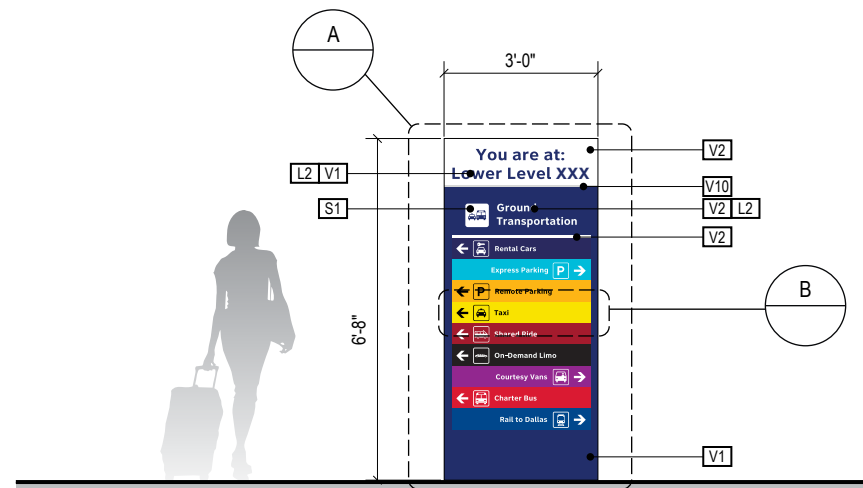

2 ELEVATION - Terminal Exit View

Scale: 1/4" = 1'-0"

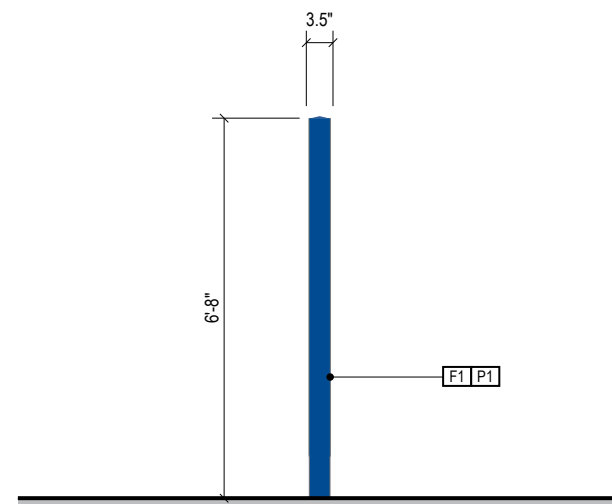

3 SIDE VIEW

Scale: 1/4" = 1'-0"

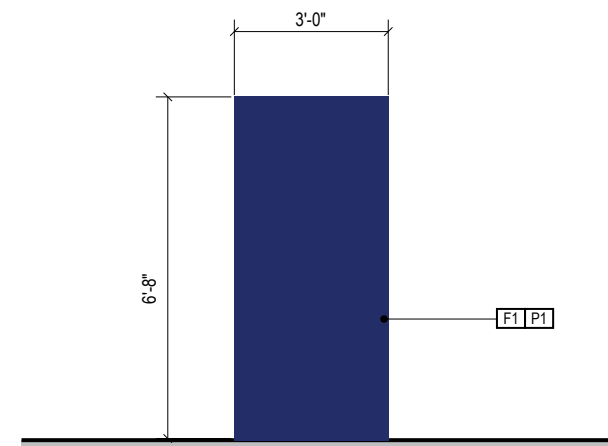

4 ELEVATION - Curbside View

Scale: 1/4" = 1'-0"

GRAPHICS / COLORS / DECORATION NOTES

- L2** Typeface: font = ClearviewText Bold
 - S1** Universal Symbols: use only official DFW symbol artwork
 - S2** Arrow(s): use only official DFW wayfinding arrow artwork
- VINYL (FILM):
- V1** Blue: 3M EC 7725-37 Sapphire Blue
 - V2** White: 3M 7725-20 Opaque Matte White
 - V10** Light Gray: To match PMS Cool Gray 1C Opaque with Matte Finish
- PAINT:
- P1** Blue: Powder coated polyester TGIC #PLSF21528PT

WARNING:

This record contains Sensitive Security Information that is controlled under 49 CFR parts 15 and 1520. No part of this record may be disclosed to persons with a "need to know," as defined in 49 CFR parts 15 and 1520, except with the written permission of the Administrator of the Transportation Security Administration or the Secretary of Transportation. Unauthorized release may result in civil penalty or other action. For U.S. government agencies, public disclosure is governed by 5 U.S.C. 552 and 49 CFR parts 15 and 1520.

ILLUMINATION	SIGN TYPE	SIGN FUNCTION	MOUNTING METHOD	GENERAL DESCRIPTION & USE
INTERNAL	3-DR.51	DIRECTIONAL/ID	SUSPENDED	Ceiling Suspended Entry Directional Sign

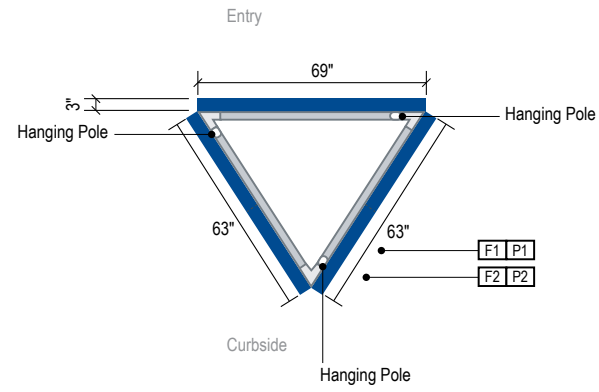

1 PLAN VIEW
Scale: 1/4" = 1'-0"

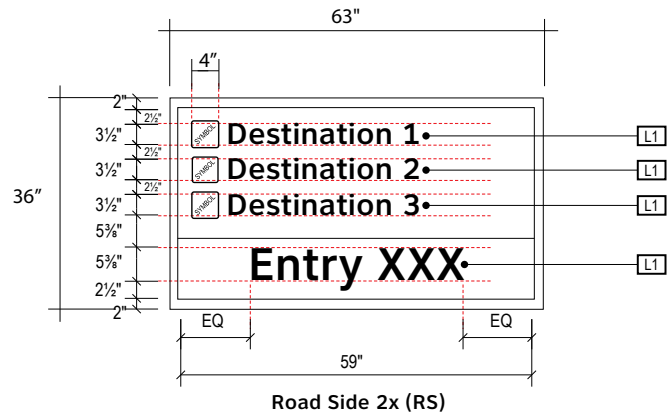

A DETAIL A: FACE LAYOUT
Scale: 1/4" = 1'-0"

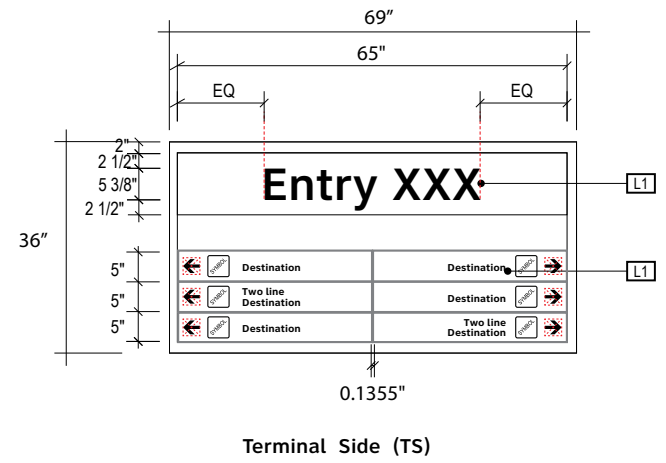

Terminal Side (TS)

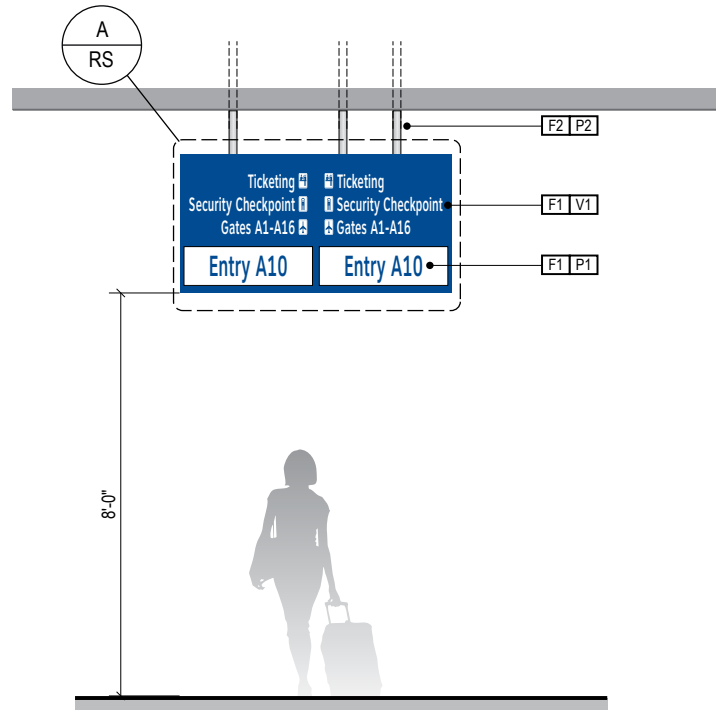

2 ELEVATION GARAGE VIEW
Scale: 1/4" = 1'-0"

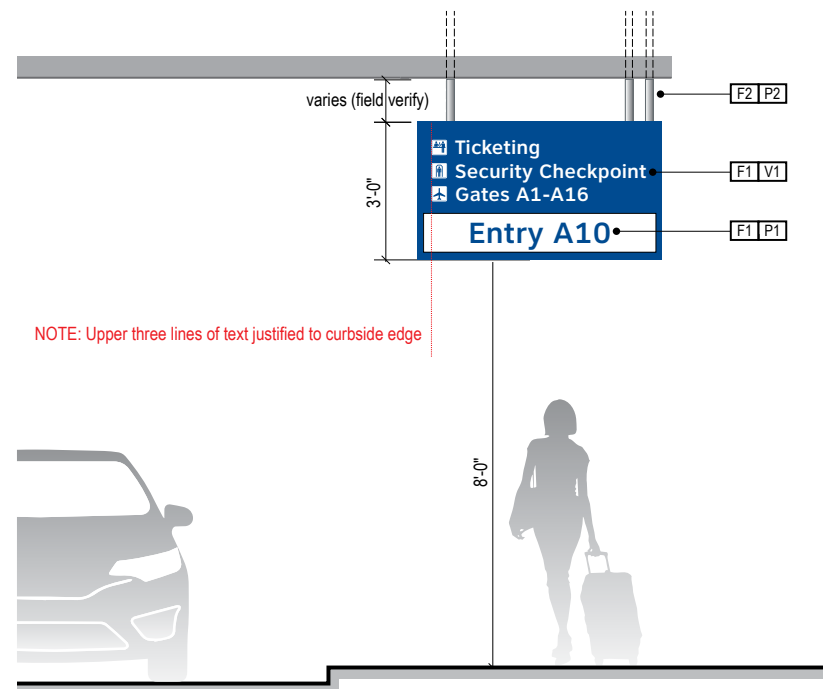

3 ROAD VIEW
Scale: 1/4" = 1'-0"

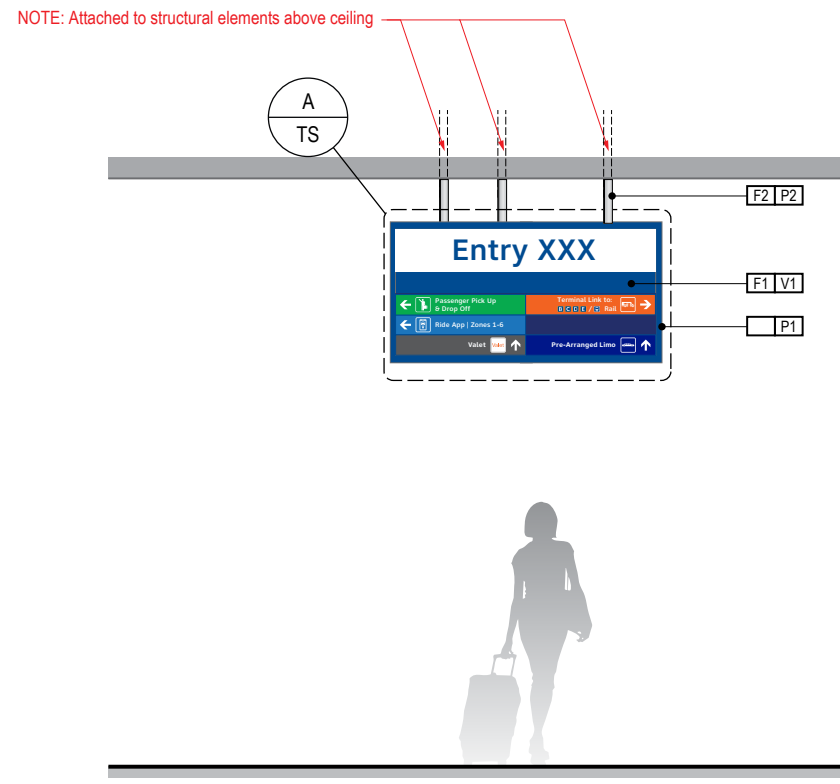

4 ELEVATION (OPPOSITE SIDE) ENTRY VIEW
Scale: 1/4" = 1'-0"

GENERAL NOTES

- All final design, engineering, and amount/sizing of structural sign support elements, material types/thicknesses, dimensions, and attachment methods shall be performed and approved by a licensed engineer to meet or exceed all applicable local and national codes.
- Final engineering, dimensions, materials, and fabrication are the responsibility of the Fabricator to ensure the highest quality fit and finish for all components of the completed product. All final detailing and specifications to be provided by the Fabricator within their final approved fabrication-ready shop drawings.
- Whenever dissimilar metals are in contact, always separate contact surfaces prior to assembly or installation with the necessary protective coatings/gaskets/washers to prevent galvanic corrosion.
- Final fabrication methods, quality and finish to be reviewed and approved by DFW Planning Department and wayfinding/architecture Design Consultants thru prototype reviews prior to final production run/installation processes (see Performance Specifications for details).
- Colors shown are for reference only, and are subject to the limitations of the printing process and/or variance of electronic RGB screen displays. Refer to color system swatches and/or final finish samples for accurate reference.
- Messages shown here are general placeholders only. Contractor to provide artwork for sign face at each entrance location.

FABRICATION INTENT NOTES

- F1** D/F ENTRY DIRECTIONAL SIGN: .063" T fabricated aluminum sign cabinet with replaceable acrylic face panels; internal LED illumination, interior of sign cabinet to be painted matte white; face panels to be Plexiglas #2447 with 3M 7725-37 "Sapphire Blue" vinyl film applied first surface, graphics are reverse weeded to backlight as white; all exposed surfaces to be finished with powder coat polyester TGIC #PLSF21528PT (Blue)
- F2** Hanger Covers: 2" diameter tube hanger covers to conceal engineered hangers as specified by state licensed structural engineer; electrical feed to also be concealed in hanger covers; provide an escutcheon plate at ceiling junction; paint all exposed surfaces with MAP paint to match P2, satin finish

GRAPHICS / COLORS / DECORATION NOTES

- L1** Typeface: font = ClearviewText Medium
- S1** Universal Symbols: use only official DFW Airport symbol artwork
- S2** Arrow(s): use only official DFW Airport wayfinding arrow artwork
- VINYL (FILM) / DIGITAL PRINT:
V1 Blue: 3M EC 7725-37 Sapphire Blue
- PAINT:
P1 Blue: Powder coated polyester TGIC #PLSF21528PT
P2 Silver: MAP paint # MP30136, satin finish

WARNING:

This record contains Sensitive Security Information that is controlled under 49 CFR parts 15 and 1520. No part of this record may be disclosed to persons with a "need to know," as defined in 49 CFR parts 15 and 1520, except with the written permission of the Administrator of the Transportation Security Administration or the Secretary of Transportation. Unauthorized release may result in civil penalty or other action. For U.S. government agencies, public disclosure is governed by 5 U.S.C. 552 and 49 CFR parts 15 and 1520.

ILLUMINATION	SIGN TYPE	SIGN FUNCTION	MOUNTING METHOD	GENERAL DESCRIPTION & USE
INTERNAL	3-ID.02	IDENTIFICATION	SUSPENDED	Ceiling Suspended Curbside Check-In ID

GENERAL NOTES

- All final design, engineering, and amount/sizing of structural sign support elements, material types/thicknesses, dimensions, and attachment methods shall be performed and approved by a licensed engineer to meet or exceed all applicable local and national codes.
- Final engineering, dimensions, materials, and fabrication are the responsibility of the Fabricator to ensure the highest quality fit and finish for all components of the completed product. All final detailing and specifications to be provided by the Fabricator within their final approved fabrication-ready shop drawings.
- Wherever dissimilar metals are in contact, always separate contact surfaces prior to assembly or installation with the necessary protective coatings/gaskets/washers to prevent galvanic corrosion.
- Final fabrication methods, quality and fit/finish to be reviewed and approved by DFW Planning Department and wayfinding/architecture Design Consultants thru prototype reviews prior to final production run/installation processes (see Performance Specifications for details).
- Colors shown are for reference only, and are subject to the limitations of the printing process and/or variance of electronic RGB screen displays. Refer to color system swatches and/or final finish samples for accurate reference.
- Messages shown here are general placeholders only. See graphic message schedules for specific messaging by location and sign type.

FABRICATION INTENT NOTES

- [F1]** D/F ENTRY ID: .063" T fabricated aluminum sign cabinet with replaceable acrylic face panels; internal LED illumination, interior of sign cabinet to be painted matte white; face panels to be Plexiglas #2447 with 3M 7725-37 "Sapphire Blue" vinyl film applied first surface, graphics are reverse weeded to backlight as white; all exposed surfaces to be finished with powder coat polyester TGIC #PLSF21528PT (Blue)
- [F2]** Hanger Covers: 2" diameter tube hanger covers to conceal engineered hangers as specified by state licensed structural engineer; electrical feed to also be concealed in hanger covers; provide an escutcheon plate at ceiling junction; paint all exposed surfaces with MAP paint to match P2, satin finish

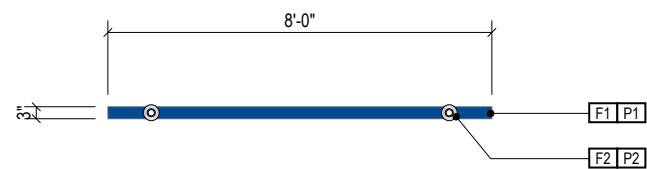

1 PLAN VIEW
Scale: 1/4" = 1'-0"

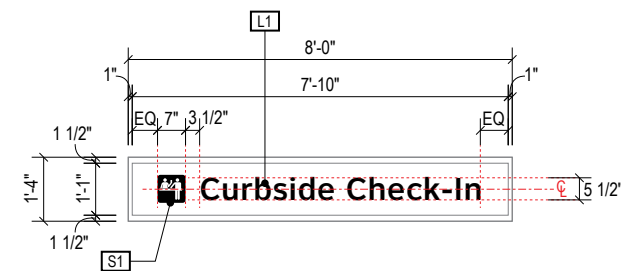

A DETAIL A: Face Layout
Scale: 1/4" = 1'-0"

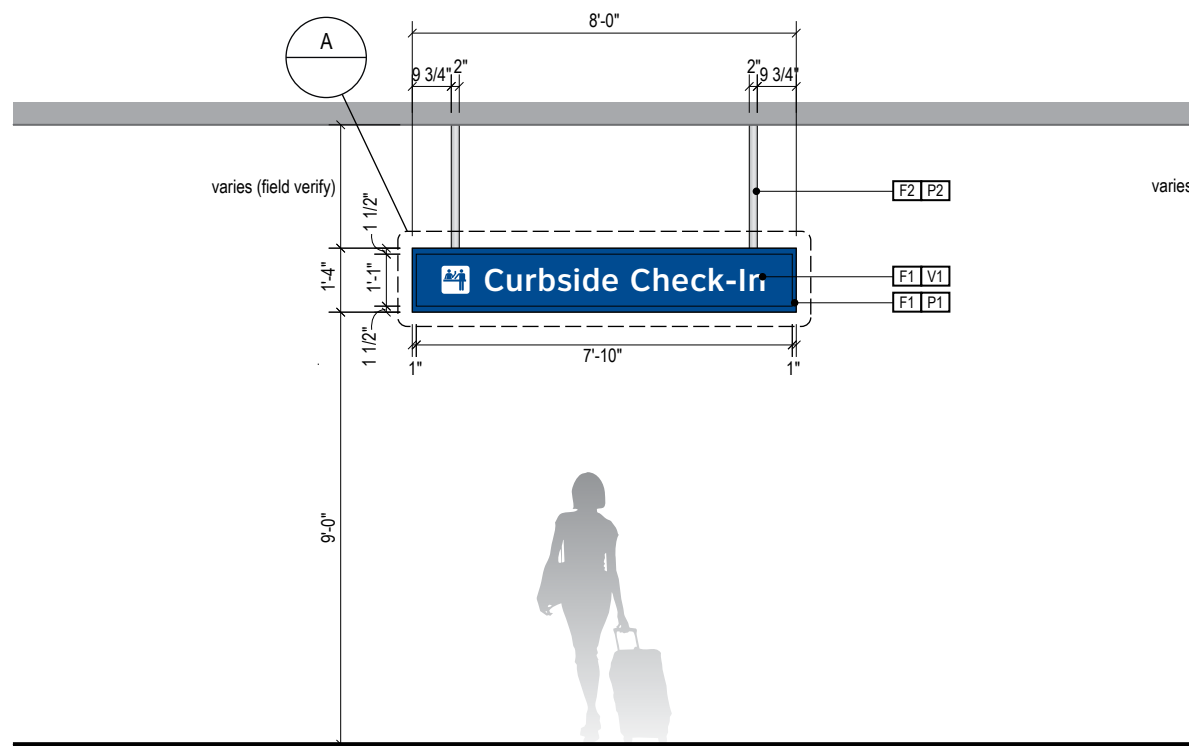

2 ELEVATION
Scale: 1/4" = 1'-0"

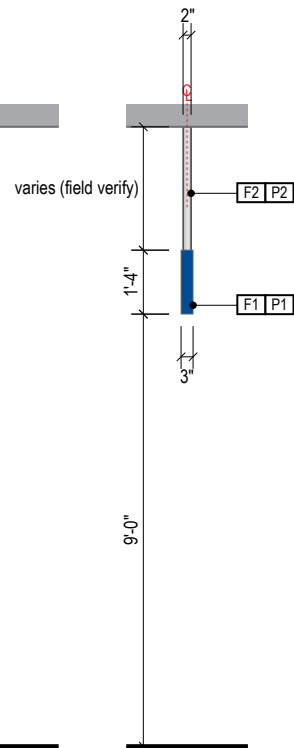

3 END VIEW
Scale: 1/4" = 1'-0"

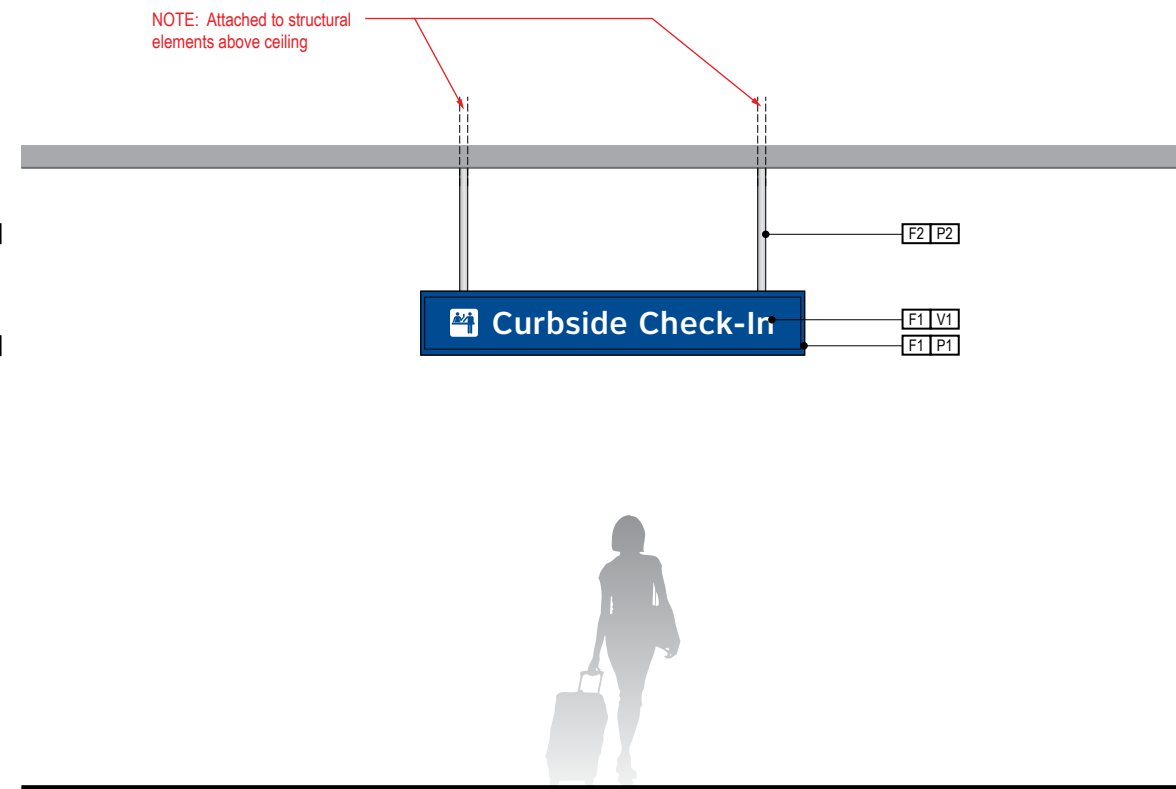

4 ELEVATION (OPPOSITE SIDE)
Scale: 1/4" = 1'-0"

GRAPHICS / COLORS / DECORATION NOTES

- [L1]** Typeface: font = ClearviewText Medium
- [S1]** Universal Symbols: use only official DFW Airport symbol artwork
- [S2]** Arrow(s): use only official DFW Airport wayfinding arrow artwork
- VINYL (FILM) / DIGITAL PRINT:**
- [V1]** Blue: 3M EC 7725-37 Sapphire Blue
- PAINT:**
- [P1]** Blue: Powder coated polyester TGIC #PLSF21528PT
- [P2]** Silver: MAP paint # MP30136, satin finish

WARNING:

This record contains Sensitive Security Information that is controlled under 49 CFR parts 15 and 1520. No part of this record may be disclosed to persons with a "need to know," as defined in 49 CFR parts 15 and 1520, except with the written permission of the Administrator of the Transportation Security Administration or the Secretary of Transportation. Unauthorized release may result in civil penalty or other action. For U.S. government agencies, public disclosure is governed by 5 U.S.C. 552 and 49 CFR parts 15 and 1520.

ILLUMINATION	SIGN TYPE	SIGN FUNCTION	MOUNTING METHOD	GENERAL DESCRIPTION & USE
INTERNAL	3-ID.20	IDENTIFICATION	FASCIA MOUNT	Entry ID at Lower Level Elevator Core (Typical)

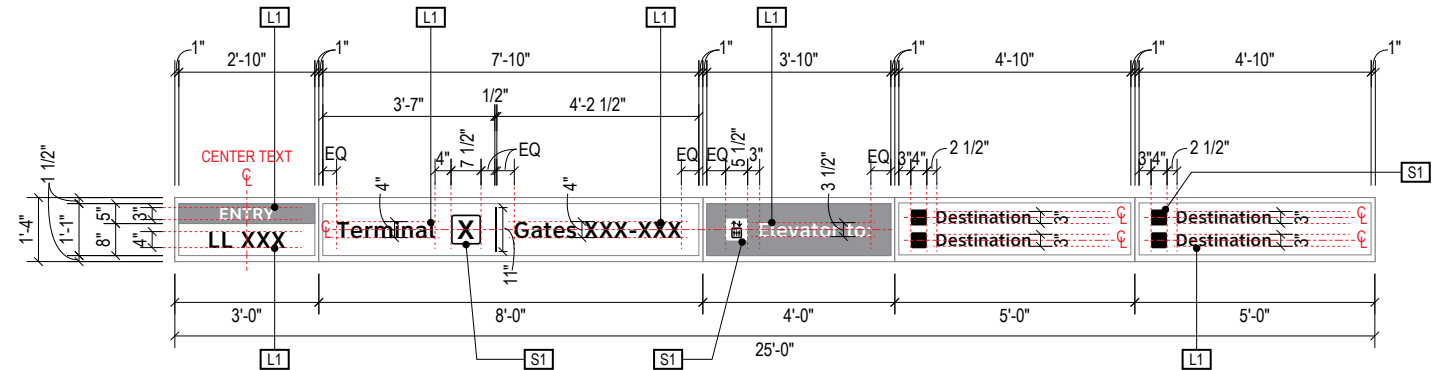

A DETAIL A: Face Layout
Scale: 1/4" = 1'-0"

NOTE: Elevation shown is typical example only; elevation varies per level and each unique terminal entrance location's conditions; field verify each location

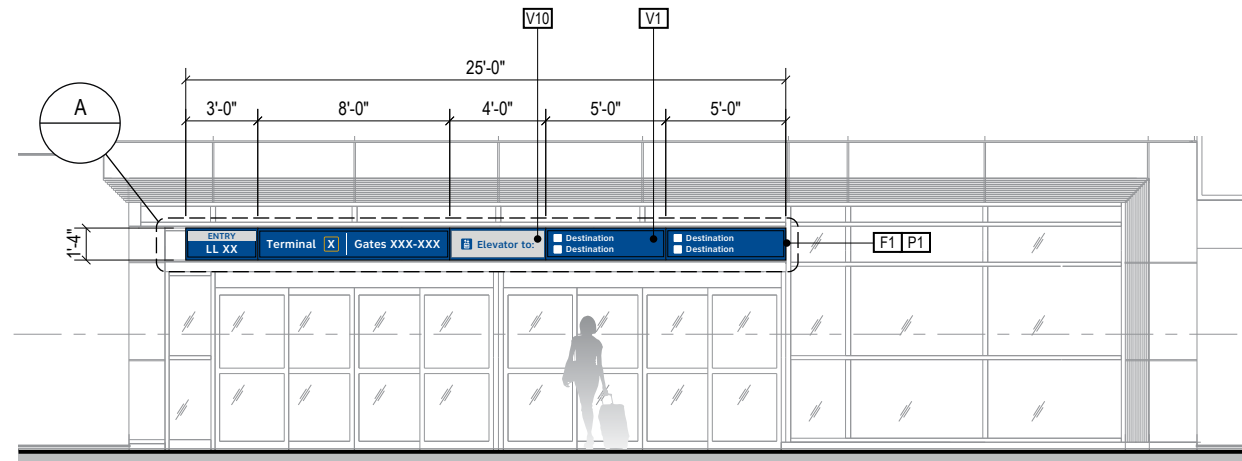

1 ELEVATION (TYPICAL)
Scale: 1/8" = 1'-0"

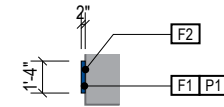

2 END VIEW
Scale: 1/8" = 1'-0"

GENERAL NOTES

- All final design, engineering, and amount/sizing of structural sign support elements, material types/thicknesses, dimensions, and attachment methods shall be performed and approved by a licensed engineer to meet or exceed all applicable local and national codes.
- Final engineering, dimensions, materials, and fabrication are the responsibility of the Fabricator to ensure the highest quality fit and finish for all components of the completed product. All final detailing and specifications to be provided by the Fabricator within their final approved fabrication-ready shop drawings.
- Wherever dissimilar metals are in contact, always separate contact surfaces prior to assembly or installation with the necessary protective coatings/gaskets/washers to prevent galvanic corrosion.
- Final fabrication methods, quality and fit/finish to be reviewed and approved by DFW Airport Planning Department and wayfinding/architecture Design Consultants thru prototype reviews prior to final production run/installation processes (see Performance Specifications for details).
- Colors shown are for reference only, and are subject to the limitations of the printing process and/or variance of electronic RGB screen displays. Refer to color system swatches and/or final finish samples for accurate reference.
- Messages shown here are general placeholders only. See graphic message schedules for specific messaging by location and sign type.

FABRICATION INTENT NOTES

- F1** CABINETS:
 - SIGN CABINET: two-piece extruded aluminum frame; cabinet has internal hinges at bottom to allow removal of face frame for access to copy panel and LED light module; powdercoat all exposed surfaces to match P1, satin finish
 - FACE FRAME: hinged at bottom and secured with FHMS at top; translucent white, 3/16" thick acrylic copy panel with first surface applied vinyl; V1 is secured to face frame with .090" thick aluminum retainers inside frame; frame slides forward on hinges and pivots 15 degree maximum to remove
 - BACK FRAME: hinged at bottom to receive face frame; contains LED light module; 1/8" thick aluminum sheet back panel is welded to extruded frame; receives mounting bracket and "Z" clips for mounting to angled mounting bracket
- F2** MOUNTING: mount to wall structural elements with connection system as installation location conditions require; provide seal at all exterior wall penetrations (Fabricator to coordinate connection location/type of structural elements with General Contractor)

GRAPHICS / COLORS / DECORATION NOTES

- L1** Typeface: font = ClearviewText Medium
- S1** Universal Symbols: use only official DFW Airport symbol artwork
VINYL (FILM) / DIGITAL PRINT:
- V1** Blue: 3M EC 7725-37 Sapphire Blue
- V10** Light Gray: 3M translucent to match PMS Cool Gray 1C
- PAINT:
- P1** Blue: Powder coated polyester TGIC #PLSF21528PT

WARNING:

This record contains Sensitive Security Information that is controlled under 49 CFR parts 15 and 1520. No part of this record may be disclosed to persons with a "need to know," as defined in 49 CFR parts 15 and 1520, except with the written permission of the Administrator of the Transportation Security Administration or the Secretary of Transportation. Unauthorized release may result in civil penalty or other action. For U.S. government agencies, public disclosure is governed by 5 U.S.C. 552 and 49 CFR parts 15 and 1520.

ILLUMINATION	SIGN TYPE	SIGN FUNCTION	MOUNTING METHOD	GENERAL DESCRIPTION & USE
INTERNAL	3-ID.21	IDENTIFICATION	FASCIA MOUNT	Entry ID at Upper or Lower Level Terminal Entrance Doors (Typical)

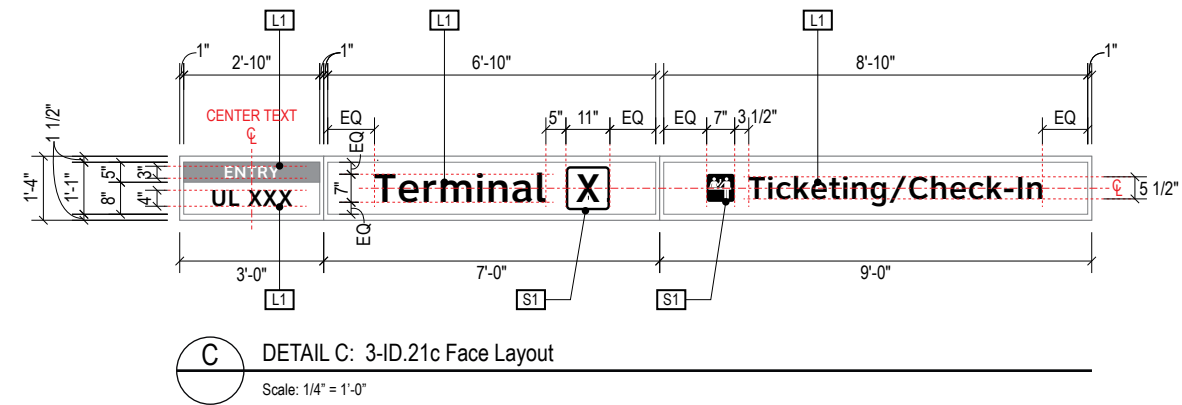
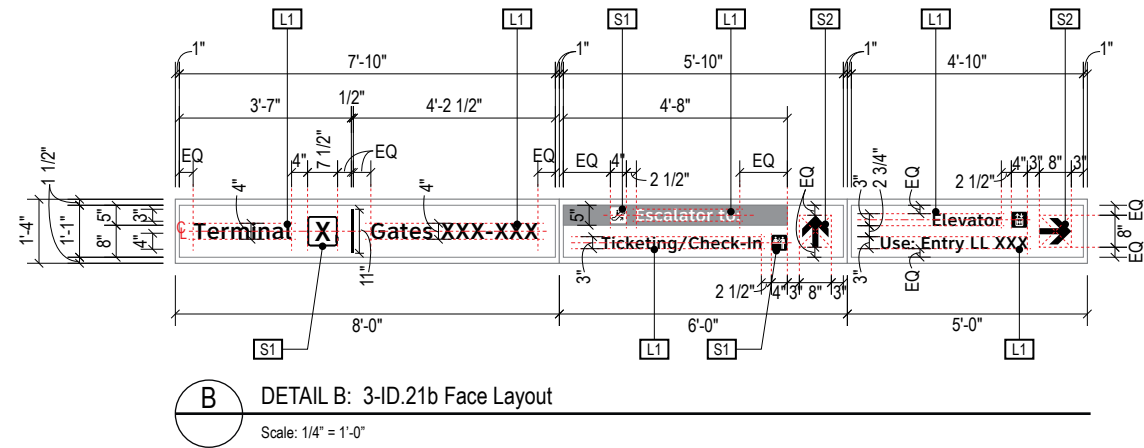
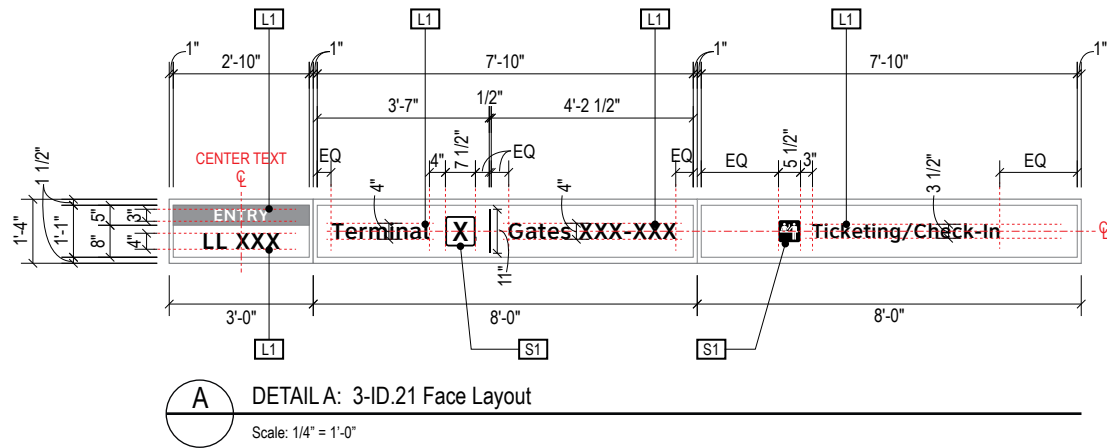

NOTE: Elevation shown is typical example only; elevation varies per level and each unique terminal entrance location's conditions; field verify each location

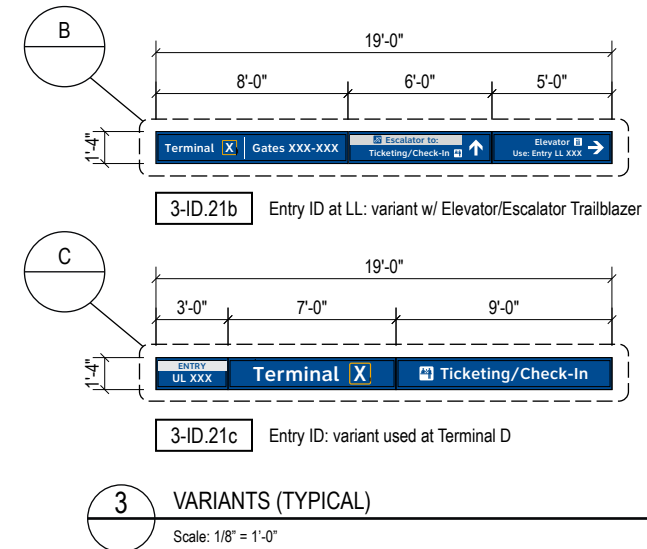
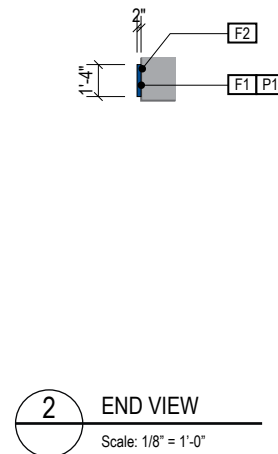
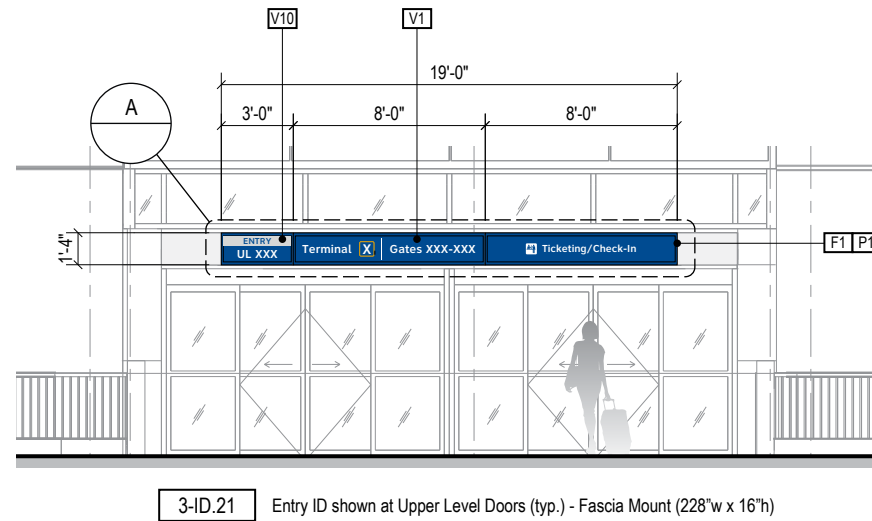

GENERAL NOTES

- All final design, engineering, and amount/sizing of structural sign support elements, material types/thicknesses, dimensions, and attachment methods shall be performed and approved by a licensed engineer to meet or exceed all applicable local and national codes.
- Final engineering, dimensions, materials, and fabrication are the responsibility of the Fabricator to ensure the highest quality fit and finish for all components of the completed product. All final detailing and specifications to be provided by the Fabricator within their final approved fabrication-ready shop drawings.
- Wherever dissimilar metals are in contact, always separate contact surfaces prior to assembly or installation with the necessary protective coatings/gaskets/washers to prevent galvanic corrosion.
- Final fabrication methods, quality and fit/finish to be reviewed and approved by DFW Airport Planning Department and wayfinding/architecture Design Consultants thru prototype reviews prior to final production run/installation processes (see Performance Specifications for details).
- Colors shown are for reference only, and are subject to the limitations of the printing process and/or variance of electronic RGB screen displays. Refer to color system swatches and/or final finish samples for accurate reference.
- Messages shown here are general placeholders only. See graphic message schedules for specific messaging by location and sign type.

FABRICATION INTENT NOTES

- F1** CABINETS:
- SIGN CABINET: two-piece extruded aluminum frame; cabinet has internal hinges at bottom to allow removal of face frame for access to copy panel and LED light module; powdercoat all exposed surfaces to match P1, satin finish
 - FACE FRAME: hinged at bottom and secured with FHMS at top; translucent white, 3/16" thick acrylic copy panel with first surface applied vinyl; V1 is secured to face frame with .090" thick aluminum retainers inside frame; frame slides forward on hinges and pivots 15 degree maximum to remove
 - BACK FRAME: hinged at bottom to receive face frame; contains LED light module; 1/8" thick aluminum sheet back panel is welded to extruded frame; receives mounting bracket and "Z" clips for mounting to angled mounting bracket
- F2** MOUNTING: mount to wall structural elements with connection system as installation location conditions require; provide seal at all exterior wall penetrations (Fabricator to coordinate connection location/type of structural elements with General Contractor)

GRAPHICS / COLORS / DECORATION NOTES

- L1** Typeface: font = ClearviewText Medium
 - S1** Universal Symbols: use only official DFW symbol artwork
 - S2** Arrow(s): use only official DFW wayfinding arrow artwork
- VINYL (FILM) / DIGITAL PRINT:
- V1** Blue: 3M EC 7725-37 Sapphire Blue
 - V10** Light Gray: 3M translucent to match PMS Cool Gray 1C
- PAINT:
- P1** Blue: Powder coated polyester TGIC #PLSF21528PT

ILLUMINATION	SIGN TYPE	SIGN FUNCTION	MOUNTING METHOD	GENERAL DESCRIPTION & USE
NON-ILLUMINATED	3-ID.71	ID/Informational	Column Wrap	Upper Level Ground Transportation Column Wrap ID on Existing Canopy

GENERAL NOTES

- All final design, engineering, and amount/sizing of structural sign support elements, material types/thicknesses, dimensions, and attachment methods shall be performed and approved by a licensed engineer to meet or exceed all applicable local and national codes.
- Final engineering, dimensions, materials, and fabrication are the responsibility of the Fabricator to ensure the highest quality fit and finish for all components of the completed product. All final detailing and specifications to be provided by the Fabricator within their final approved fabrication-ready shop drawings.
- Wherever dissimilar metals are in contact, always separate contact surfaces prior to assembly or installation with the necessary protective coatings/gaskets/washers to prevent galvanic corrosion.
- Final fabrication methods, quality and fit/finish to be reviewed and approved by DFW Planning Department and wayfinding/architecture Design Consultants thru prototype reviews prior to final production run/installation processes (see Performance Specifications for details).
- Colors shown are for reference only, and are subject to the limitations of the printing process and/or variance of electronic RGB screen displays. Refer to color system swatches and/or final finish samples for accurate reference.
- Messages shown here are general placeholders only. See graphic message schedules for specific messaging by location and sign type.

FABRICATION INTENT NOTES

- F1** COLUMN WRAP HALF: .125" aluminum sheet, router cut per pattern and break-formed shape; to receive additional welded components and digitally printed graphic wrap; thoroughly clean aluminum prior to application of vinyl wrap with Dupont Prep-Sol or owner approved equal
- F2** COLUMN WRAP GRAPHIC: digitally printed graphic on 3M 1080-S10 "Satin White" cast vinyl film; print with OEM latex ink for printer used; graphic to wrap all edges so that no bare metal is visible once halves are assembled; thoroughly clean aluminum prior to application of vinyl wrap with Dupont Prep-Sol or owner approved equal
- F3** BUMP BAR/BRACKET: 2" diameter x .125" wall 6061-T6 aluminum round tube; miter corners, continuous weld, grind and fill smooth as required; number 4 horizontal finish; weld to bump bar bracket with continuous fillet weld, grind and fill smooth as required; bracket to be 5" x 1.5" 6061-T6511 aluminum flat bar, miter corners, continuous weld, grind and fill smooth as required; number 4 horizontal finish; bolt bump bar/bracket to existing facility column with Hilti Kwik Bolt TZ SS 316 as specified by state licensed engineer
- F4** BASE WRAP (if used): 12 guage (.1046") 316 stainless steel sheet; cut per pattern and break-formed wings for attachment points; number 4 finish, grain to run vertically; screws to bump bar brackets with 1/4-20 FHMS; hardware to be 316 or 18-8 stainless steel

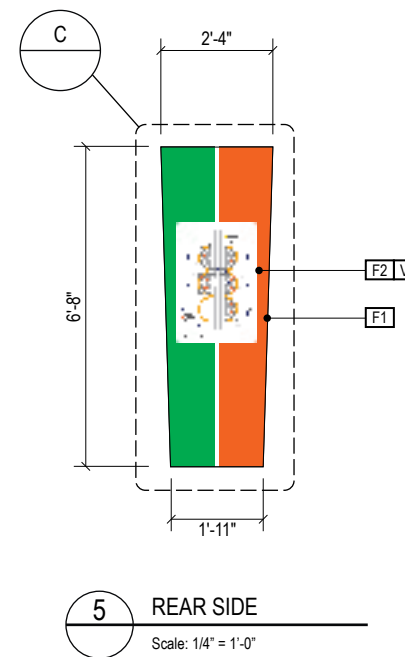
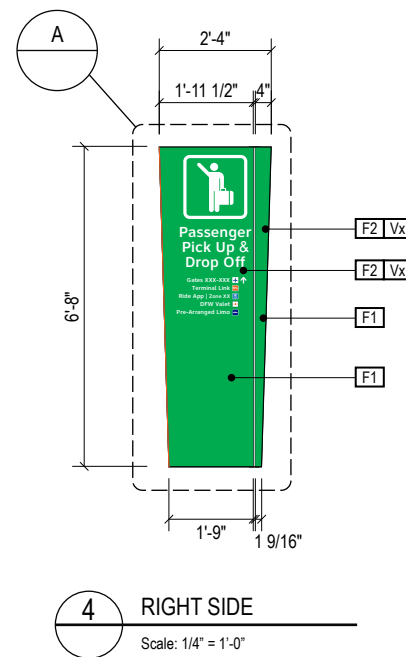
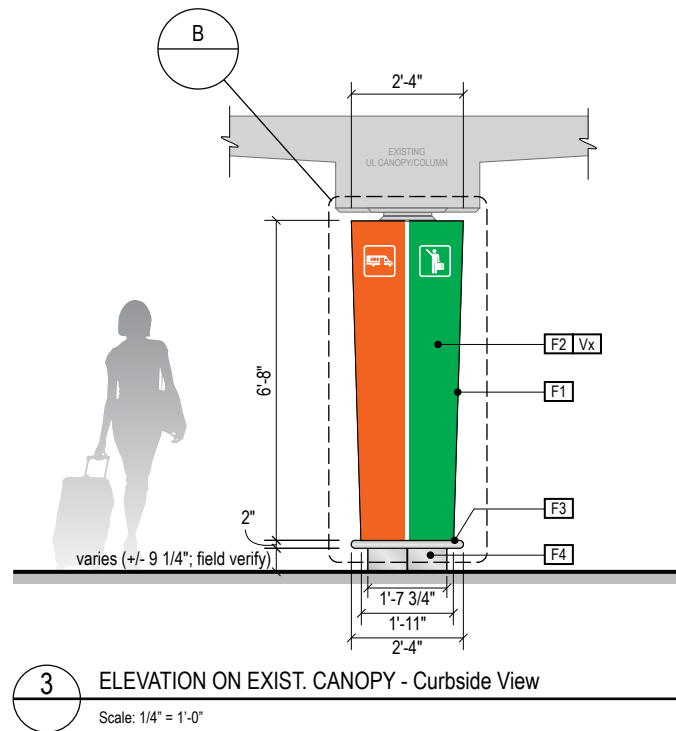
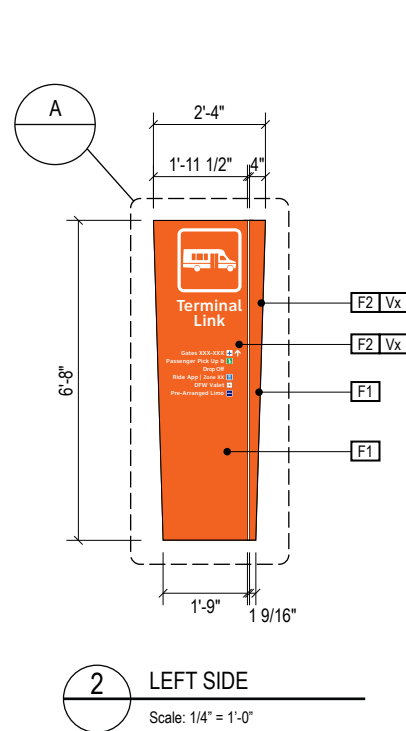
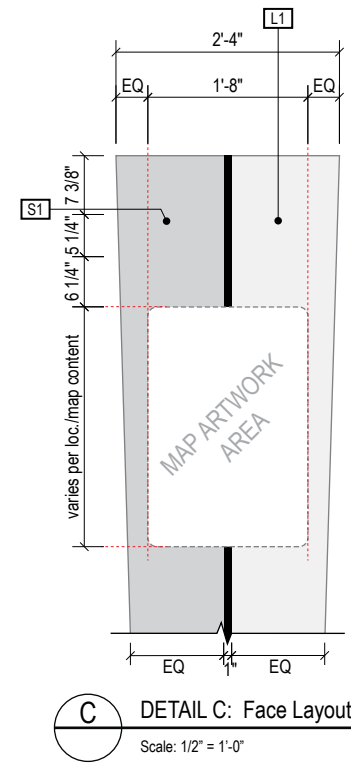
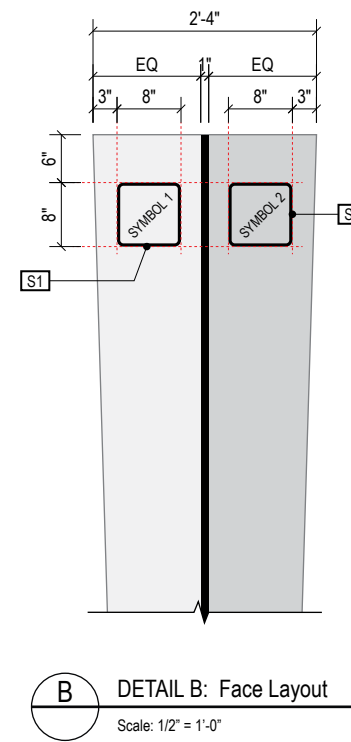
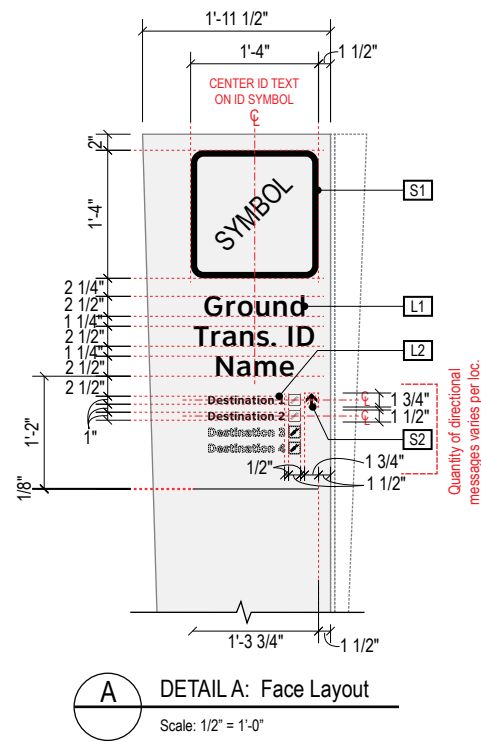
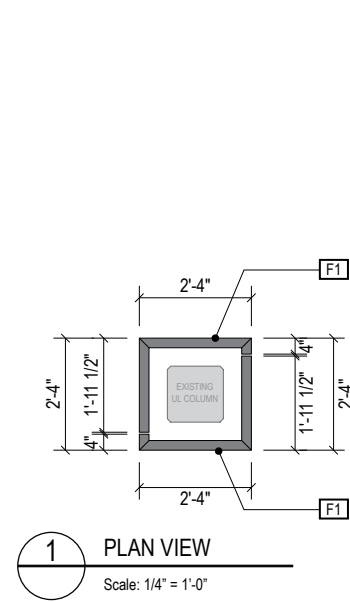

GRAPHICS / COLORS / DECORATION NOTES

- L1** Typeface: font = ClearviewText Medium
- L2** Typeface: font = ClearviewText Bold
- S1** Universal Symbols: use only official DFW Airport symbol artwork
- S2** Arrow(s): use only official DFW wayfinding arrow artwork
- VINYL (FILM) / DIGITAL PRINT:
- Vx** Curbside/G.T. Digital Print Colors: See Sheet 2-14

ILLUMINATION	SIGN TYPE	SIGN FUNCTION	MOUNTING METHOD	GENERAL DESCRIPTION & USE
NON-ILLUMINATED	3-ID.72	ID/Informational	Column Wrap	LL Ground Transportation ID

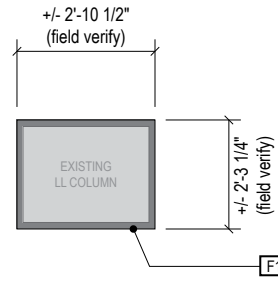

1 PLAN VIEW
Scale: 1/4" = 1'-0"

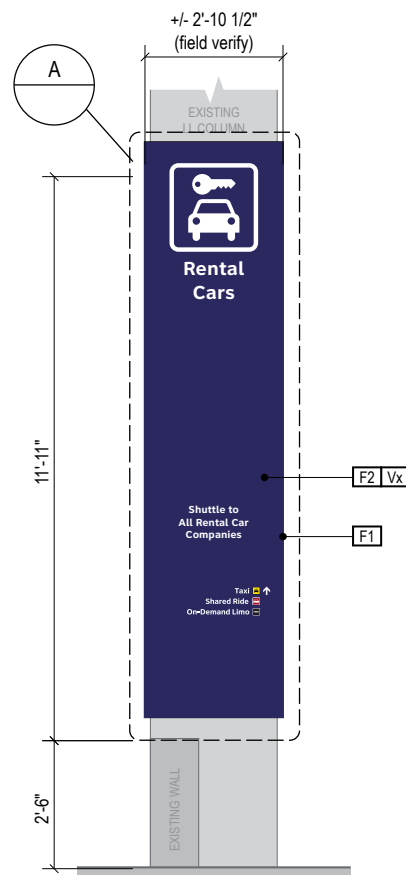

2 LEFT SIDE
Scale: 1/4" = 1'-0"

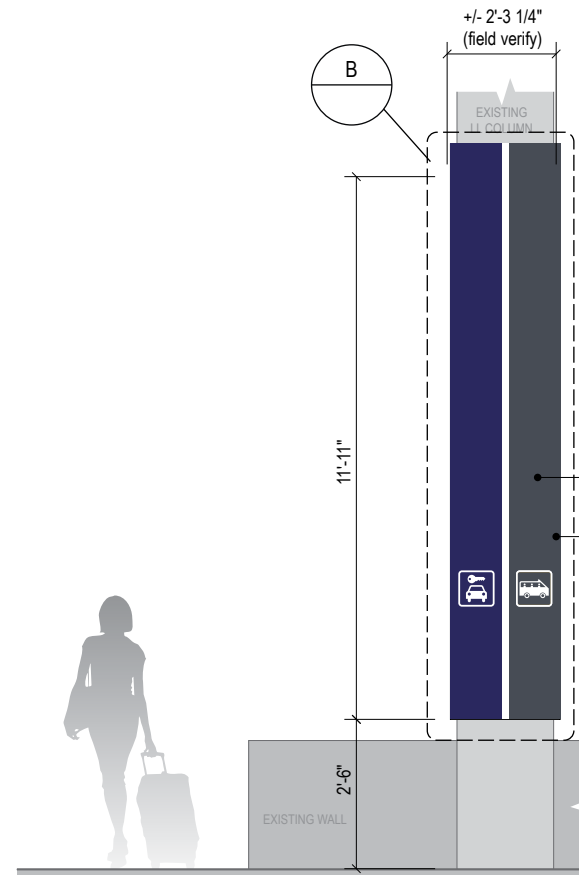

3 ELEVATION (View from Curb)
Scale: 1/4" = 1'-0"

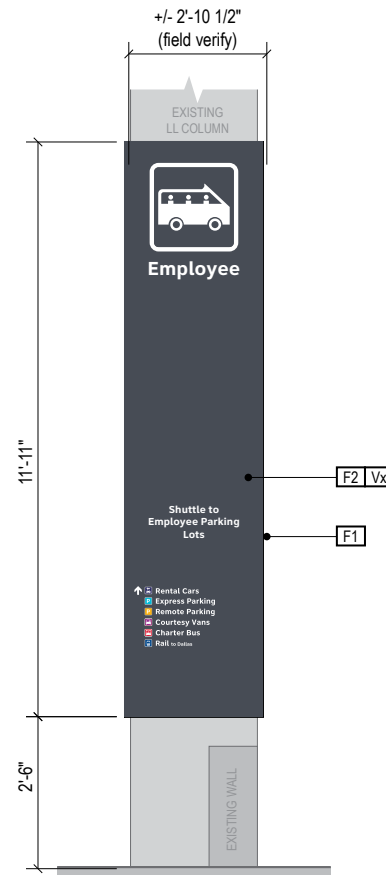

4 RIGHT SIDE
Scale: 1/4" = 1'-0"

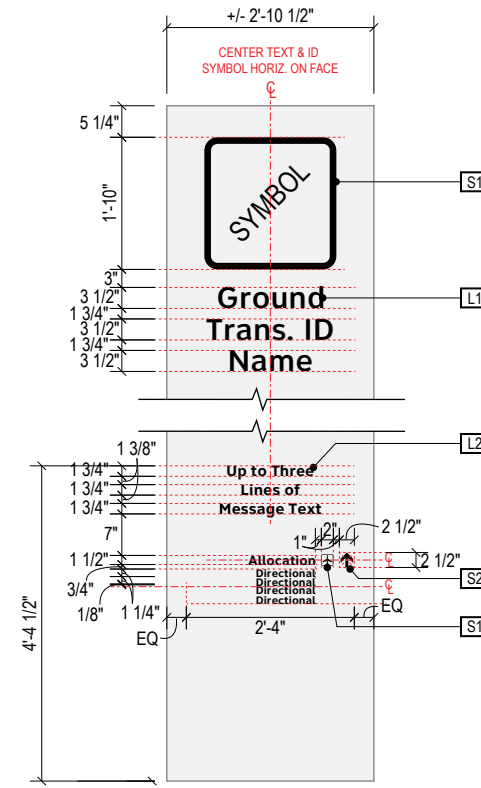

A DETAIL A: Face Layout
Scale: 3/8" = 1'-0"

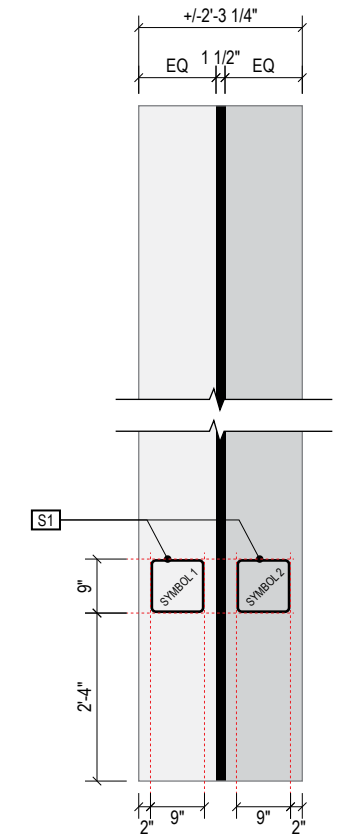

B DETAIL B: Face Layout
Scale: 3/8" = 1'-0"

GENERAL NOTES

- All final design, engineering, and amount/sizing of structural sign support elements, material types/thicknesses, dimensions, and attachment methods shall be performed and approved by a licensed engineer to meet or exceed all applicable local and national codes.
- Final engineering, dimensions, materials, and fabrication are the responsibility of the Fabricator to ensure the highest quality fit and finish for all components of the completed product. All final detailing and specifications to be provided by the Fabricator within their final approved fabrication-ready shop drawings.
- Wherever dissimilar metals are in contact, always separate contact surfaces prior to assembly or installation with the necessary protective coatings/gaskets/washers to prevent galvanic corrosion.
- Final fabrication methods, quality and fit/finish to be reviewed and approved by DFW Airport Planning Department and wayfinding/architecture Design Consultants thru prototype reviews prior to final production run/installation processes (see Performance Specifications for details).
- Colors shown are for reference only, and are subject to the limitations of the printing process and/or variance of electronic RGB screen displays. Refer to color system swatches and/or final finish samples for accurate reference.
- Messages shown here are general placeholders only. See graphic message schedules for specific messaging by location and sign type.

FABRICATION INTENT NOTES

- F1** COLUMN WRAP PANELS: .125" 6061-T5 aluminum sheet, mill finish; panel to receive digital print graphic vinyl film application; thoroughly clean aluminum prior to application of vinyl wrap with Dupont Prep-Sol or owner approved equal; mount panels to column-wrap framing with 3M VHB tape #4959 or owner approved equal; column wrap framing to be 1.5" x 1.5" x 1.25" 6061-T6 aluminum square tube, welded construction, grind welds smooth on faces and backs; field verify each install location; visible portions of frame are to match color of column wrap field color; front framing section to attach to side frames with appropriate mechanical fasteners from the inside of frame into backside of sides at front; all mating edges to be flush; framing section to bolt to existing concrete column with appropriate mechanical fasteners
- F2** COLUMN WRAP GRAPHIC: digitally printed graphic on 3M 1080-S10 "Satin White" cast vinyl film; print with OEM latex ink for printer used; graphic to wrap all edges so that no bare metal is visible once halves are assembled; thoroughly clean aluminum prior to application of vinyl wrap with Dupont Prep-Sol or owner approved equal

GRAPHICS / COLORS / DECORATION NOTES

- L1** Typeface: font = ClearviewText Medium
- L2** Typeface: font = ClearviewText Bold
- S1** Universal Symbols: use only official DFW Airport symbol artwork
- S2** Arrow(s): use only official DFW Airport wayfinding arrow artwork
- VINYL (FILM) / DIGITAL PRINT:
- Vx** Curbside/G.T. Digital Print Colors: See Sheet 2-14

WARNING:

This record contains Sensitive Security Information that is controlled under 49 CFR parts 15 and 1520. No part of this record may be disclosed to persons with a "need to know," as defined in 49 CFR parts 15 and 1520, except with the written permission of the Administrator of the Transportation Security Administration or the Secretary of Transportation. Unauthorized release may result in civil penalty or other action. For U.S. government agencies, public disclosure is governed by 5 U.S.C. 552 and 49 CFR parts 15 and 1520.

ILLUMINATION	SIGN TYPE	SIGN FUNCTION	MOUNTING METHOD	GENERAL DESCRIPTION & USE
NON-ILLUMINATED	3-ID.72a	ID/Informational	Fascia Mounted	LL Ground Transportation ID

GENERAL NOTES

- All final design, engineering, and amount/sizing of structural sign support elements, material types/thicknesses, dimensions, and attachment methods shall be performed and approved by a licensed engineer to meet or exceed all applicable local and national codes.
- Final engineering, dimensions, materials, and fabrication are the responsibility of the Fabricator to ensure the highest quality fit and finish for all components of the completed product. All final detailing and specifications to be provided by the Fabricator within their final approved fabrication-ready shop drawings.
- Wherever dissimilar metals are in contact, always separate contact surfaces prior to assembly or installation with the necessary protective coatings/gaskets/washers to prevent galvanic corrosion.
- Final fabrication methods, quality and finish to be reviewed and approved by DFW Airport Planning Department and wayfinding/architecture Design Consultants thru prototype reviews prior to final production run/installation processes (see Performance Specifications for details).
- Colors shown are for reference only, and are subject to the limitations of the printing process and/or variance of electronic RGB screen displays. Refer to color system swatches and/or final finish samples for accurate reference.
- Messages shown here are general placeholders only. See graphic message schedules for specific messaging by location and sign type.

FABRICATION INTENT NOTES

- [F1]** COLUMN WRAP PANELS: .125" 6061-T5 aluminum sheet, mill finish; panel to receive digital print graphic vinyl film application; thoroughly clean aluminum prior to application of vinyl wrap with Dupont Prep-Sol or owner approved equal; mount panels to column-wrap framing with 3M VHB tape #4959 or owner approved equal; column wrap framing to be 1.5" x 1.5" x 1.25" 6061-T6 aluminum square tube, welded construction, grind welds smooth on faces and backs; field verify each install location; visible portions of frame are to match color of column wrap field color; front framing section to attach to side frames with appropriate mechanical fasteners from the inside of frame into backside of sides at front; all mating edges to be flush; framing section to bolt to existing concrete column with appropriate mechanical fasteners
- [F2]** COLUMN WRAP GRAPHIC: digitally printed graphic on 3M 1080-S10 "Satin White" cast vinyl film; print with OEM latex ink for printer used; graphic to wrap all edges so that no bare metal is visible once halves are assembled; thoroughly clean aluminum prior to application of vinyl wrap with Dupont Prep-Sol or owner approved equal

GRAPHICS / COLORS / DECORATION NOTES

- [L1]** Typeface: font = ClearviewText Medium
- [L2]** Typeface: font = ClearviewText Bold
- [S1]** Universal Symbols: use only official DFW Airport symbol artwork
- [S2]** Arrow(s): use only official DFW Airport wayfinding arrow artwork
- VINYL (FILM) / DIGITAL PRINT:
- [Vx]** Curbside/G.T. Digital Print Colors: See Sheet 2-14

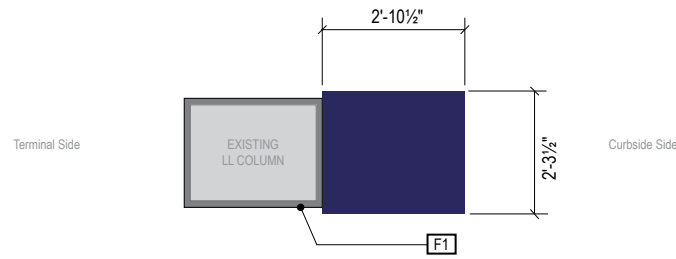

1 PLAN VIEW
Scale: NTS

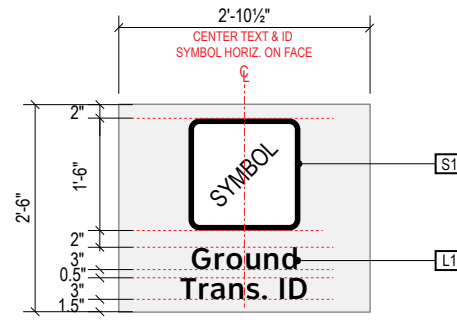

A DETAIL A: Side Face Layout
Scale: NTS

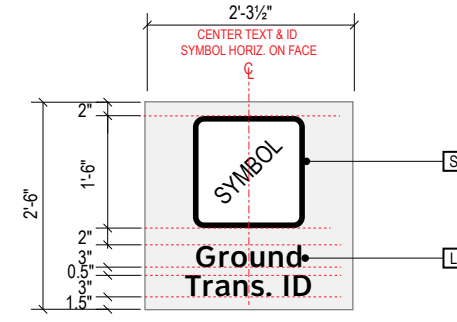

B DETAIL A: Front Face Layout
Scale: NTS

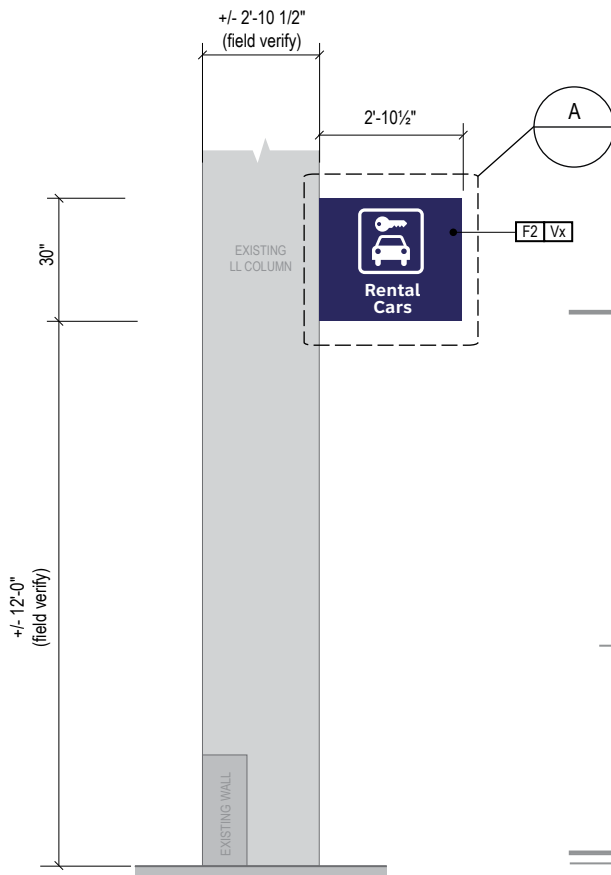

2 LEFT SIDE
Scale: NTS

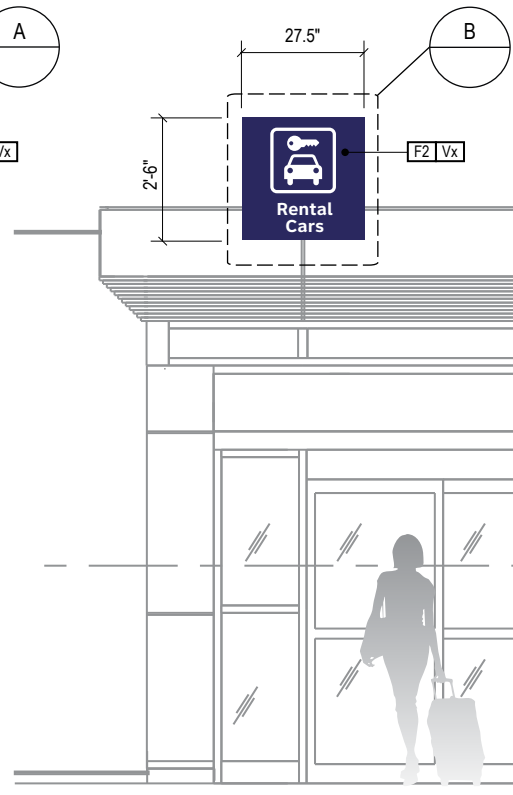

3 ELEVATION (View from Curb)
Scale: 1/4" = NTS

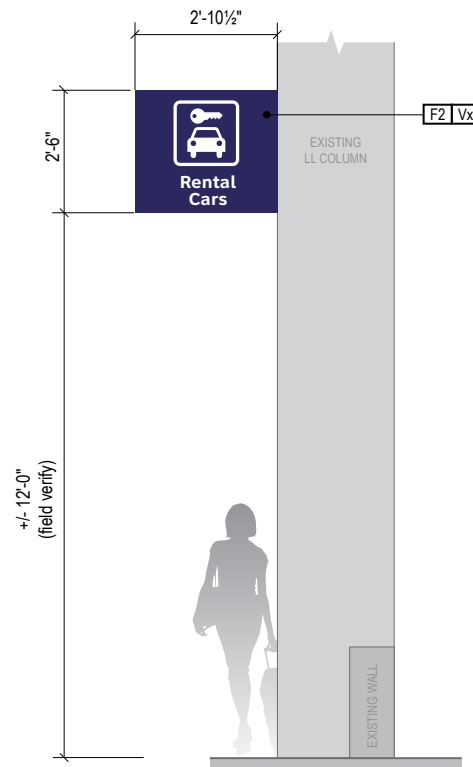

4 RIGHT SIDE
Scale: NTS

WARNING:

This record contains Sensitive Security Information that is controlled under 49 CFR parts 15 and 1520. No part of this record may be disclosed to persons with a "need to know," as defined in 49 CFR parts 15 and 1520, except with the written permission of the Administrator of the Transportation Security Administration or the Secretary of Transportation. Unauthorized release may result in civil penalty or other action. For U.S. government agencies, public disclosure is governed by 5 U.S.C. 552 and 49 CFR parts 15 and 1520.

ILLUMINATION	SIGN TYPE	SIGN FUNCTION	MOUNTING METHOD	GENERAL DESCRIPTION & USE
NON-ILLUMINATED	3-ID.40	ID/Informational	Blade	LL Smoking and Non-Smoking

GENERAL NOTES

- All final design, engineering, and amount/sizing of structural sign support elements, material types/thicknesses, dimensions, and attachment methods shall be performed and approved by a licensed engineer to meet or exceed all applicable local and national codes.
- Final engineering, dimensions, materials, and fabrication are the responsibility of the Fabricator to ensure the highest quality fit and finish for all components of the completed product. All final detailing and specifications to be provided by the Fabricator within their final approved fabrication-ready shop drawings.
- Wherever dissimilar metals are in contact, always separate contact surfaces prior to assembly or installation with the necessary protective coatings/gaskets/washers to prevent galvanic corrosion.
- Final fabrication methods, quality and fit/finish to be reviewed and approved by DFW Airport Planning Department and wayfinding/architecture Design Consultants thru prototype reviews prior to final production run/installation processes (see Performance Specifications for details).
- Colors shown are for reference only, and are subject to the limitations of the printing process and/or variance of electronic RGB screen displays. Refer to color system swatches and/or final finish samples for accurate reference.
- Messages shown here are general placeholders only. See graphic message schedules for specific messaging by location and sign type.

FABRICATION INTENT NOTES

- F1** D/F Regulatory Sign: 25" T aluminum plate panel and ceiling plate. Blind weld panel to ceiling plate. Ease all edges. Assembled sign bolts to existing cast concrete curb canopy at centerline of canopy column, 3" out from face of column capital.
- F2** Digital Print Graphics: 1 each per side, 12" x 12" contour cut graphics on exterior grade cast vinyl film 3M Controllac Graphic Film 8620Cv3 or equal.
- F3** Laminated Overlay: The digital print shall be protected by 3M ElectroCut film series 1170 clear UV protection film.

GRAPHICS / COLORS / DECORATION NOTES

- L1** Typeface: font = ClearviewText Medium
 - L2** Typeface: font = ClearviewText Bold
 - S1** Universal Symbols: use only official DFW Airport symbol artwork
 - S2** Arrow(s): use only official DFW Airport wayfinding arrow artwork
- VINYL (FILM):
- V2** White: 3M 7725-20 Opaque Matte White
 - V4** Exit Light Green: 3M Opaque Matte to match PMS 368C
 - V5** Black: 3M 7725-22 Opaque Matte Black
 - V6** Safety Red: 3M Opaque Matte to match PMS 485C
- PAINT:
- P2** Silver: MAP paint # MP30136, satin finish

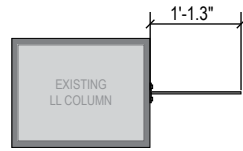

1 PLAN VIEW
Scale: 1/4" = 1'-0"

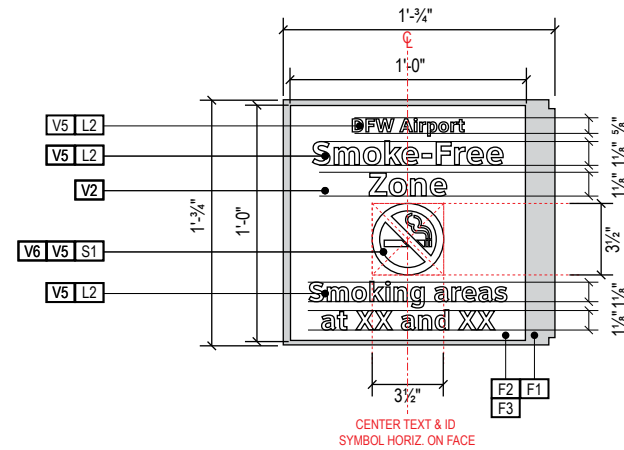

A DETAIL A: No Smoking Face Layout
NTS

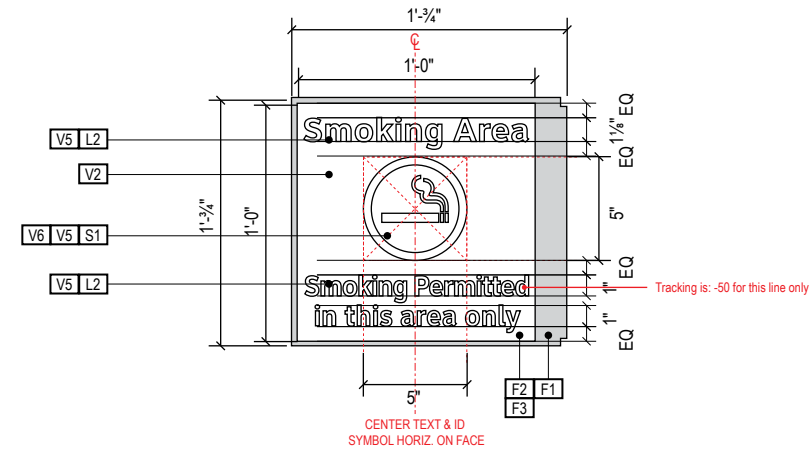

B DETAIL B: Smoking Face Layout
NTS

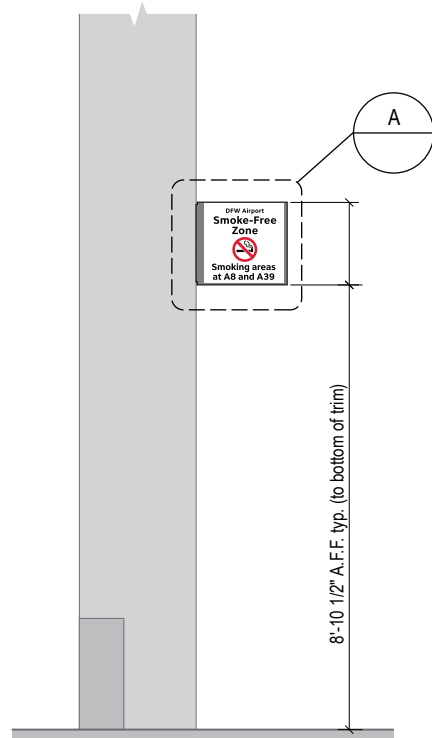

2 LEFT SIDE
Scale: 1/4" = 1'-0"

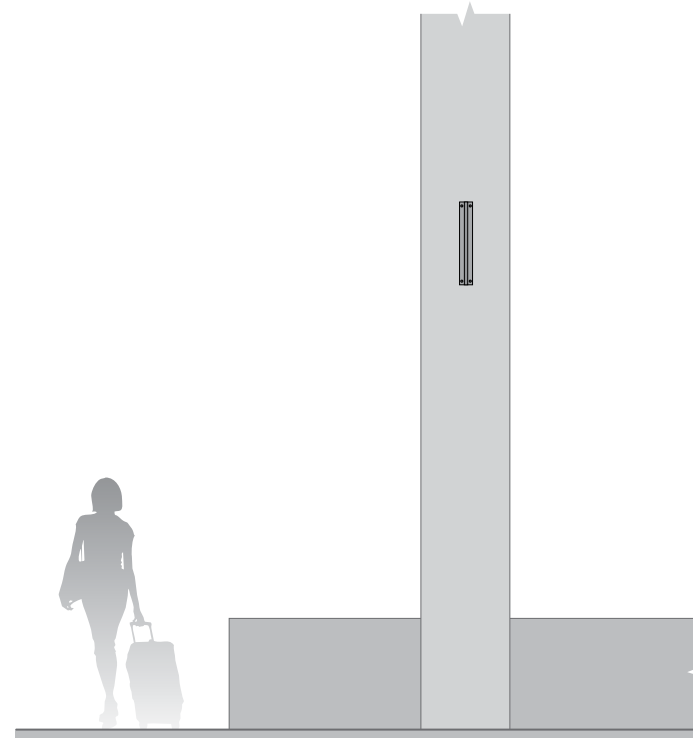

3 ELEVATION (View from Curb)
Scale: 1/4" = 1'-0"

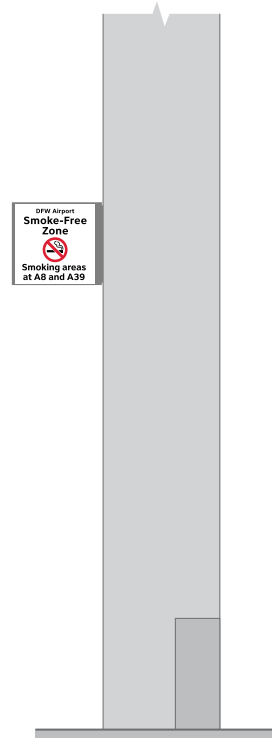

4 RIGHT SIDE
Scale: 1/4" = 1'-0"

ILLUMINATION	SIGN TYPE	SIGN FUNCTION	MOUNTING METHOD	GENERAL DESCRIPTION & USE
NON-ILLUMINATED	3-ID.03	ID/Informational	Blade	UL No Parking and No-Smoking

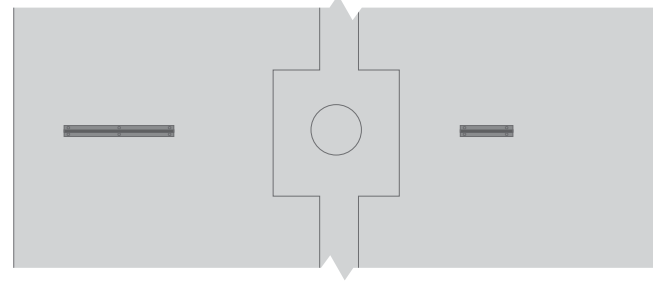

1 PLAN VIEW
Scale: 1/4" = 1'-0"

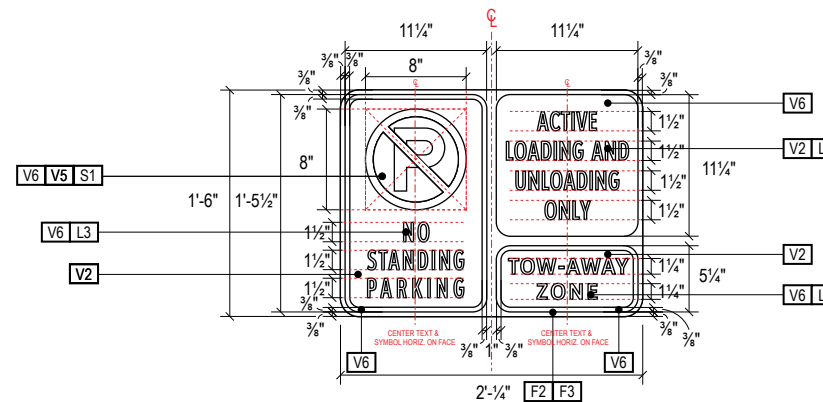

A DETAIL A: No Smoking Face Layout
NTS

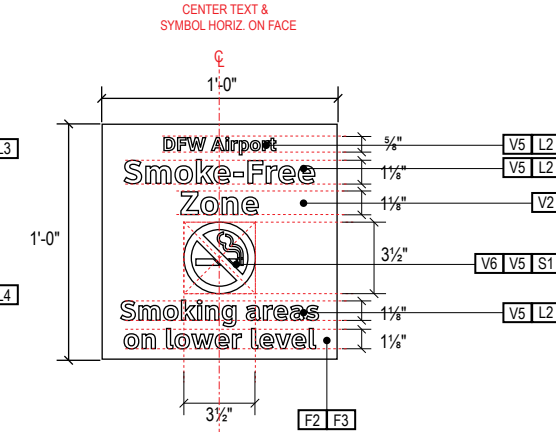

B DETAIL B: No Smoking Face Layout
NTS

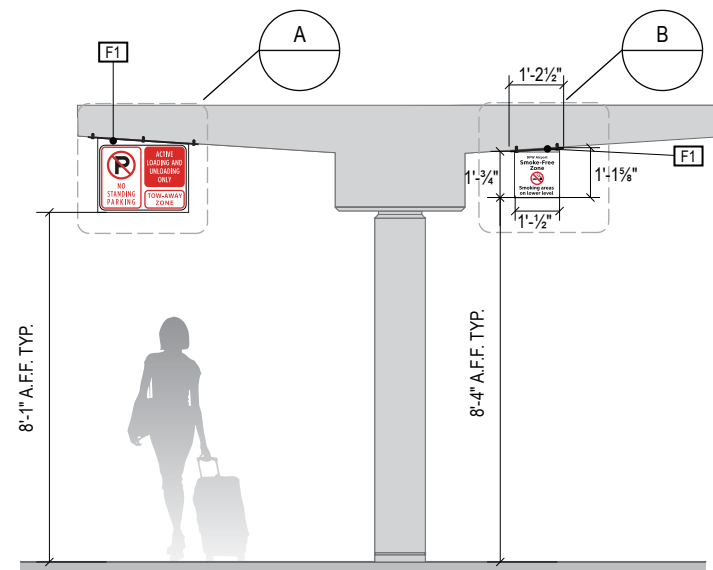

2 ELEVATION (View on Curb)
Scale: 1/4" = 1'-0"

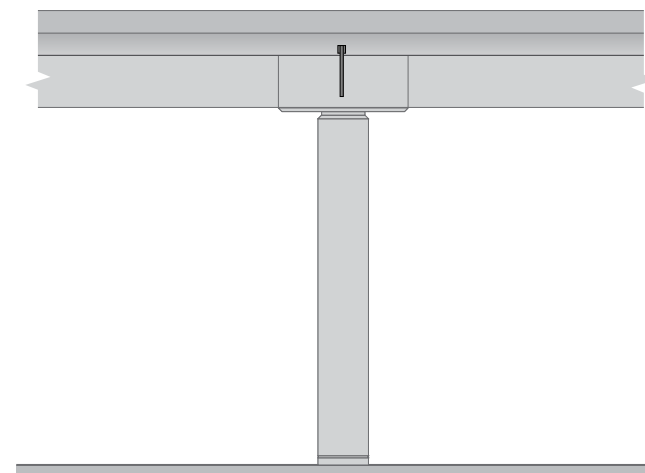

4 End view
Scale: 1/4" = 1'-0"

GENERAL NOTES

- All final design, engineering, and amount/sizing of structural sign support elements, material types/thicknesses, dimensions, and attachment methods shall be performed and approved by a licensed engineer to meet or exceed all applicable local and national codes.
- Final engineering, dimensions, materials, and fabrication are the responsibility of the Fabricator to ensure the highest quality fit and finish for all components of the completed product. All final detailing and specifications to be provided by the Fabricator within their final approved fabrication-ready shop drawings.
- Wherever dissimilar metals are in contact, always separate contact surfaces prior to assembly or installation with the necessary protective coatings/gaskets/washers to prevent galvanic corrosion.
- Final fabrication methods, quality and fit/finish to be reviewed and approved by DFW Airport Planning Department and wayfinding/architecture Design Consultants thru prototype reviews prior to final production run/installation processes (see Performance Specifications for details).
- Colors shown are for reference only, and are subject to the limitations of the printing process and/or variance of electronic RGB screen displays. Refer to color system swatches and/or final finish samples for accurate reference.
- Messages shown here are general placeholders only. See graphic message schedules for specific messaging by location and sign type.

FABRICATION INTENT NOTES

- F1** D/F Regulatory Sign: 25" T aluminum plate panel and ceiling plate. Blind weld panel to ceiling plate. Ease all edges. Assembled sign bolts to existing cast concrete curb canopy at centerline of canopy column, 3" out from face of column capital.
- F2** Digital Print Graphics: 1 each per side, 12" x 12" contour cut graphics on exterior grade cast vinyl film 3M Controllac Graphic Film 8620Cv3 or equal.
- F3** Laminated Overlay: The digital print shall be protected by 3M ElectroCut film series 1170 clear UV protection film.

GRAPHICS / COLORS / DECORATION NOTES

- L1** Typeface: font = ClearviewText Medium
 - L2** Typeface: font = ClearviewText Bold
 - L3** Typeface: font = Clearview Hwy 2-W, Interline Spacing of 2.5'
 - L4** Typeface: font = Clearview Hwy 2-B
 - S1** Universal Symbols: use only official DFW Airport symbol artwork
 - S2** Arrow(s): use only official DFW Airport wayfinding arrow artwork
- VINYL (FILM):
- V2** White: 3M 7725-20 Opaque Matte White
 - V4** Exit Light Green: 3M Opaque Matte to match PMS 368C
 - V5** Black: 3M 7725-22 Opaque Matte Black
 - V6** Safety Red: 3M Opaque Matte to match PMS 485C
- PAINT:
- P2** Silver: MAP paint # MP30136, satin finish

ILLUMINATION	SIGN TYPE	SIGN FUNCTION	MOUNTING METHOD	GENERAL DESCRIPTION & USE
NON-ILLUMINATED	3-ID.05	ID/Informational	Blade	LL No Parking and No Standing

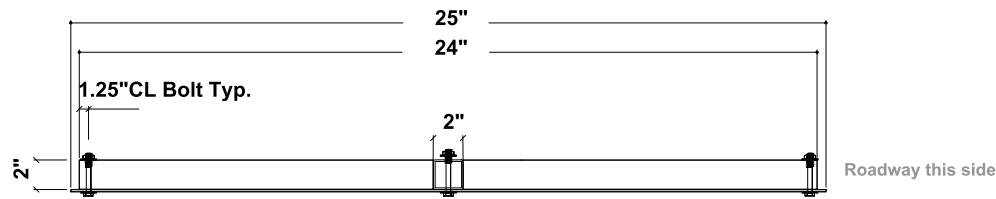

1 PLAN VIEW
Scale: 1/4" = 1'-0"

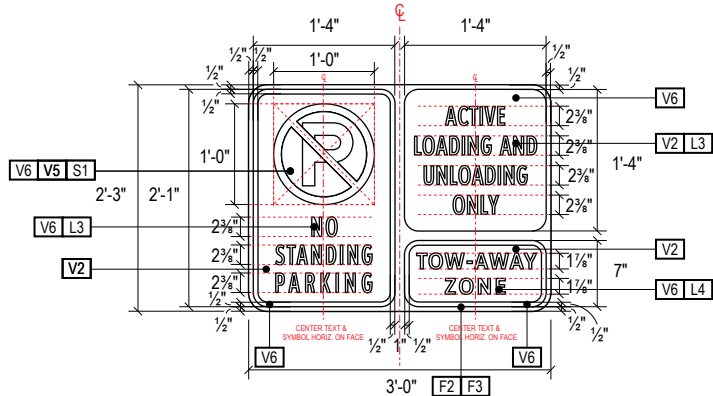

A DETAIL A: No Parking Face Layout
NTS

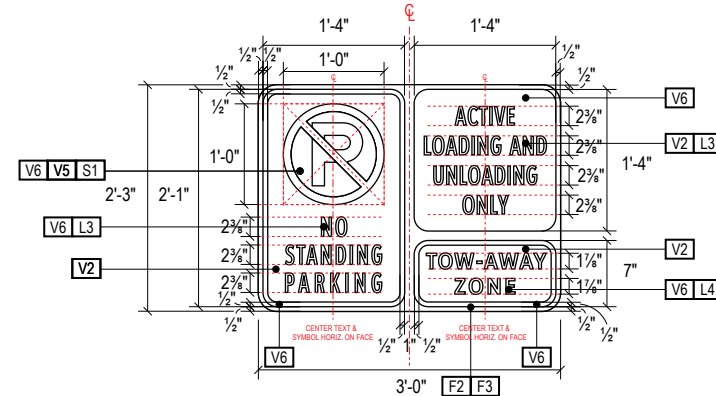

B DETAIL B: Reverse No Parking Face Layout
NTS

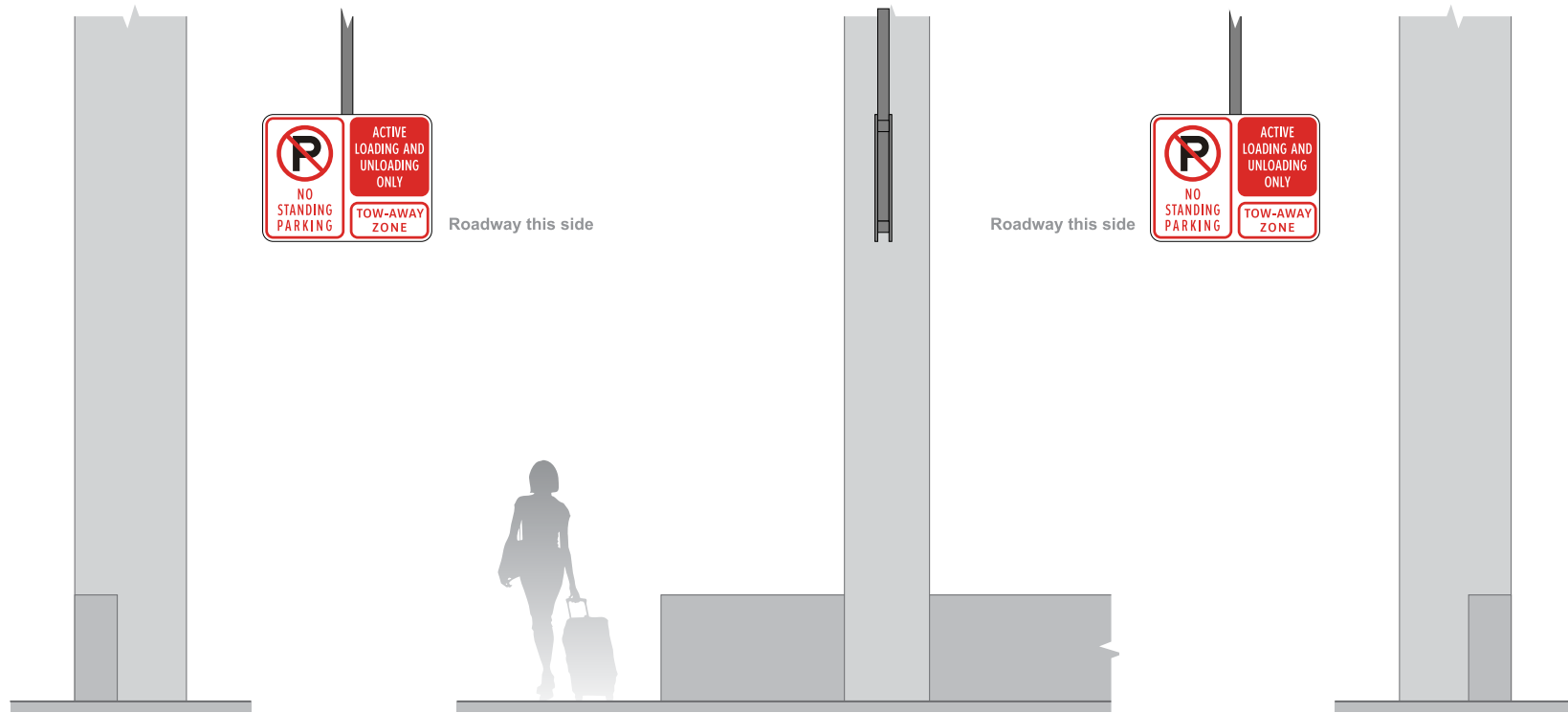

2 LEFT SIDE
Scale: 1/4" = 1'-0"

3 ELEVATION (View from Curb)
Scale: 1/4" = 1'-0"

4 RIGHT SIDE
Scale: 1/4" = 1'-0"

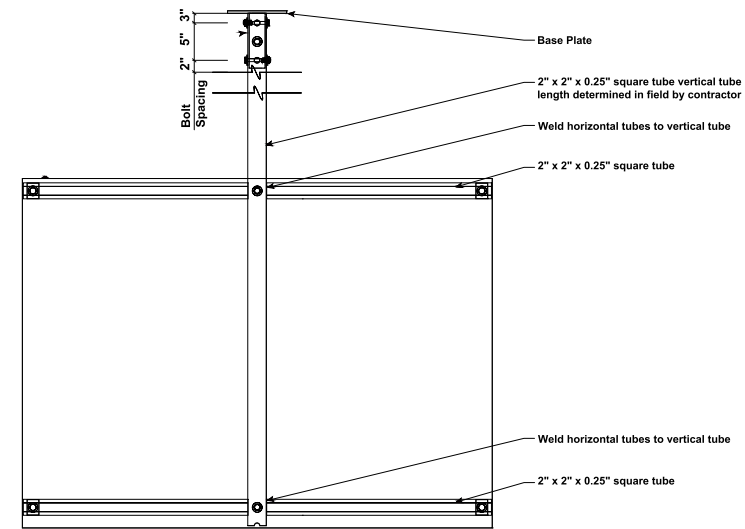

4 Construction Detail
NTS

GENERAL NOTES

- All final design, engineering, and amount/sizing of structural sign support elements, material types/thicknesses, dimensions, and attachment methods shall be performed and approved by a licensed engineer to meet or exceed all applicable local and national codes.
- Final engineering, dimensions, materials, and fabrication are the responsibility of the Fabricator to ensure the highest quality fit and finish for all components of the completed product. All final detailing and specifications to be provided by the Fabricator within their final approved fabrication-ready shop drawings.
- Wherever dissimilar metals are in contact, always separate contact surfaces prior to assembly or installation with the necessary protective coatings/gaskets/washers to prevent galvanic corrosion.
- Final fabrication methods, quality and fit/finish to be reviewed and approved by DFW Airport Planning Department and wayfinding/architecture Design Consultants thru prototype reviews prior to final production run/installation processes (see Performance Specifications for details).
- Colors shown are for reference only, and are subject to the limitations of the printing process and/or variance of electronic RGB screen displays. Refer to color system swatches and/or final finish samples for accurate reference.
- Messages shown here are general placeholders only. See graphic message schedules for specific messaging by location and sign type.

FABRICATION INTENT NOTES

- F1** D/F Regulatory Sign: 25" T aluminum plate panel and ceiling plate. Blind weld panel to ceiling plate. Ease all edges. Assembled sign bolts to existing cast concrete curb canopy at centerline of canopy column, 3" out from face of column capital.
- F2** Digital Print Graphics: 1 each per side, 12" x 12" contour cut graphics on exterior grade cast vinyl film 3M Controltac Graphic Film 8620Cv3 or equal.
- F3** Laminated Overlay: The digital print shall be protected by 3M ElectroCut film series 1170 clear UV protection film.

GRAPHICS / COLORS / DECORATION NOTES

- L1** Typeface: font = ClearviewText Medium
 - L2** Typeface: font = ClearviewText Bold
 - S1** Universal Symbols: use only official DFW Airport symbol artwork
 - S2** Arrow(s): use only official DFW Airport wayfinding arrow artwork
- VINYL (FILM):
- V2** White: 3M 7725-20 Opaque Matte White
 - V4** Exit Light Green: 3M Opaque Matte to match PMS 368C
 - V5** Black: 3M 7725-22 Opaque Matte Black
 - V6** Safety Red: 3M Opaque Matte to match PMS 485C
- PAINT:
- P2** Silver: MAP paint # MP30136, satin finish

WARNING:

This record contains Sensitive Security Information that is controlled under 49 CFR parts 15 and 1520. No part of this record may be disclosed to persons with a "need to know," as defined in 49 CFR parts 15 and 1520, except with the written permission of the Administrator of the Transportation Security Administration or the Secretary of Transportation. Unauthorized release may result in civil penalty or other action. For U.S. government agencies, public disclosure is governed by 5 U.S.C. 552 and 49 CFR parts 15 and 1520.

5.0

5.0 SIGN TYPES - ROADWAY AREAS

- 5.1 Sign Type Index
- 5.2 Sign Types

SIGN TYPE INDEX - ROADWAY AREAS

This chapter provides specific information regarding the wayfinding sign types applicable for use in the Roadway areas of DFW Airport. It contains a general sign family overview of the specific sign types (i.e., the Sign Type Index section), as well as more specific design/layouts/notes/etc for each individual sign type (i.e., the Sign Types section).

On the following pages, the Sign Type Index shows views of each sign type, as well as listings for each sign type's name, mounting method and basic overall size. The Sign Type Index is intended only as a brief, simple catalog for all of the wayfinding sign types used within the Roadway areas of DFW, and is organized in numeric order of their sign type identification numbers (i.e., Directional sign type category: 4-DR.01, 4-DR.02, etc; Identification sign type category: 4-ID.01, 4-ID.02, etc; Informational sign type category: 4-IN.01, 4-IN.02, etc).

Sign Types - Design Intent Drawings

Section 5.2 - Sign Types contains design intent drawings of each specific wayfinding sign type used within the Roadway areas of DFW Airport. Each sheet displays scaled drawings of individual sign types and their basic views (i.e., elevations, plan views, end view, etc), sizing/dimensions, face layouts and general design intent related notes.

NOTE: these documents are intended to illustrate design intent, and should only be used as a general guideline. No information contained here should be construed as engineered elements. The designer/fabricator/contractor shall be responsible for all engineering and specifications with regard to structural, electrical, mechanical, foundation and installation. Details and information contained in this document shall not be reproduced, copied or utilized in any way except for the specific project for which they were created without previous written authorization from DFW.

Mounting Requirements

Sign mountings shall support signs for optimum visibility, facilitate illumination where required, be fabricated from commonly available materials, be easily maintained, be engineered to established DFW wayfinding system and engineering requirements, and not obstruct or pose any hazard to pedestrians, vehicles or any other entity.

Basic Mounting Types

The basic mounting types used within DFW Roadway areas are as follows:

- Large Overhead Signs:
 - Span Structure - sign panel(s) (number/size vary per location and lane configuration) mechanically fastened to a large freestanding two post support structure spanning the entirety of a roadway
 - Bridge Mount Structure - sign panel(s) (number/size vary per location and lane configuration) with second surface mounted support structure grid mechanically fastened to a bridge's fascia
 - Cantilever Structure - sign panel (size varies per location and lane configuration) mechanically fastened to a large freestanding single post support structure and one support arm cantilevered over a roadway
 - Butterfly (Centered Post) Cantilever Structure - sign panel (size varies per location and lane configuration) mechanically fastened to a large freestanding single post support structure and two support arm cantilevered over roadways flanking both sides of support post
- Ground Mounted Signs:
 - Large Roadside - sign panels that are mounted to multiple (two or more) vertical posts and located laterally offset to the side of a roadway.
 - Small Roadside - sign panels that are mounted to one vertical post and located laterally offset to the side of a roadway

General Mounting Restrictions - Vehicular Signs

- Vehicular wayfinding signs shall always be mounted perpendicular to vehicular traffic flow
- Overhead and roadside signs: all mounting, lateral positioning/spacing from edge of roadway and clearances must be reviewed and approved by a traffic engineer licensed in the State of Texas prior to fabrication and installation
- Overhead and roadside signs: all elements, engineering, fabrication and materials used on roadway sign support structures must be reviewed and approved by a traffic engineer licensed in the State of Texas prior to fabrication and installation
- Ground-mounted vehicular signs (if used) must be mounted behind crash barriers, use break-away base mounting systems in the event of an accidental vehicular collision and as required by TXDOT
- Vehicular overhead signs must be mounted with the lowest element of the sign at a minimum of 17'-6" above finished grade unless otherwise indicated
- Vehicular roadside signs must be mounted with the bottom-most viewable area of the sign at a minimum of 8'-0" above finished grade unless otherwise indicated

- Whenever there is a conflict between a requirement listed in this document and another authoritative code or standard, the more stringent one shall be applied

WARNING:

This record contains Sensitive Security Information that is controlled under 49 CFR parts 15 and 1520. No part of this record may be disclosed to persons with a "need to know," as defined in 49 CFR parts 15 and 1520, except with the written permission of the Administrator of the Transportation Security Administration or the Secretary of Transportation. Unauthorized release may result in civil penalty or other action. For U.S. government agencies, public disclosure is governed by 5 U.S.C. 552 and 49 CFR parts 15 and 1520.

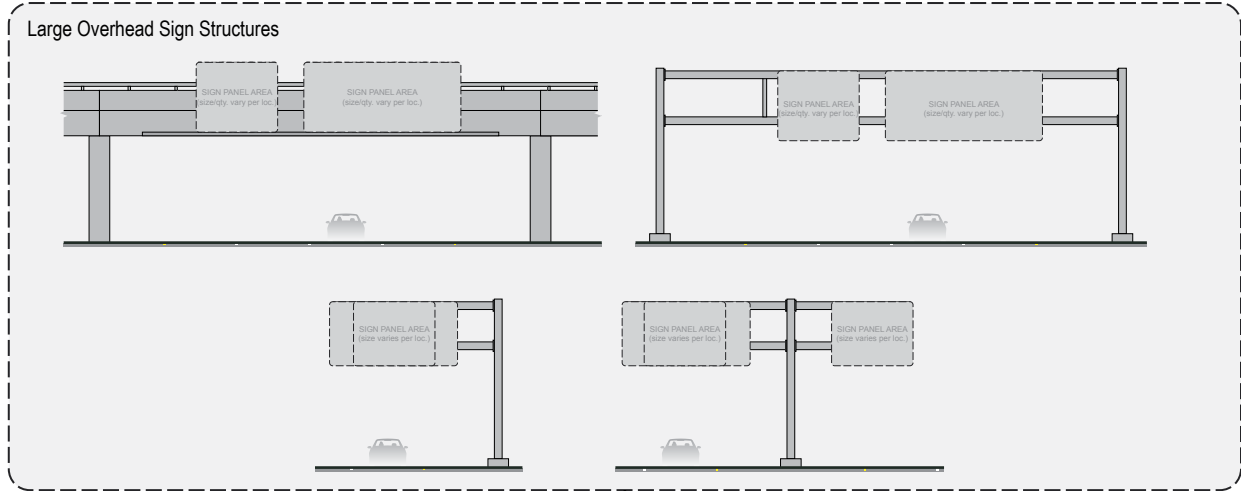

***NOTE:**
 Typical Sign Panel and Support Structure Examples Only
 Sign panels and support structures shown here are for typical example purposes only and are provided as a general design reference for as-built DFW Airport Roadway signage; for additional information/sign panel layouts/structure details, see existing as-built documents

*Typical Sign Panel Examples



4-DR.01 Overhead 1-Lane Directional Panel (15'-0" w x 14'-0" h)



4-DR.06 Overhead Directional Mileage Panel w/ Exit Header (22'-0" w x 12'-0" h)



S-NB-1 Vehicular Directional Panel - Cantilever (22'-0" w x 9'-6" h)



4-DR.02 Overhead 1-Lane Directional Panel w/ Dynamic Area (17'-0" w x 14'-0" h)



4-DR.11 Overhead 1-Lane 3-Line Directional Panel w/ Exit Header (23'-0" w x 18'-0" h)



S-NB-2 Vehicular Directional Panel - Three Line Terminal (27'-0" w x 16'-6" h)

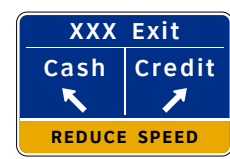

4-DR.05 Overhead Cash/Credit Directional Panel w/ Exit Header (18'-0" w x 12'-0" h)



4-DR.12 Overhead 2-Lane 3-Line Directional Panel w/ Exit Header (27'-0" w x 18'-0" h)

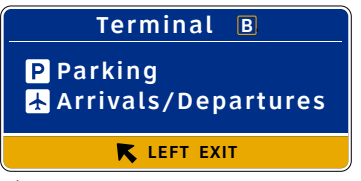

S-NB-3 Vehicular Directional Panel - Two Line Terminal (27'-0" w x 14'-0" h)

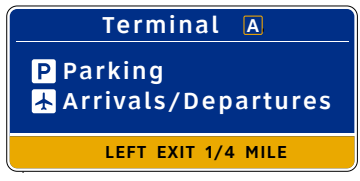
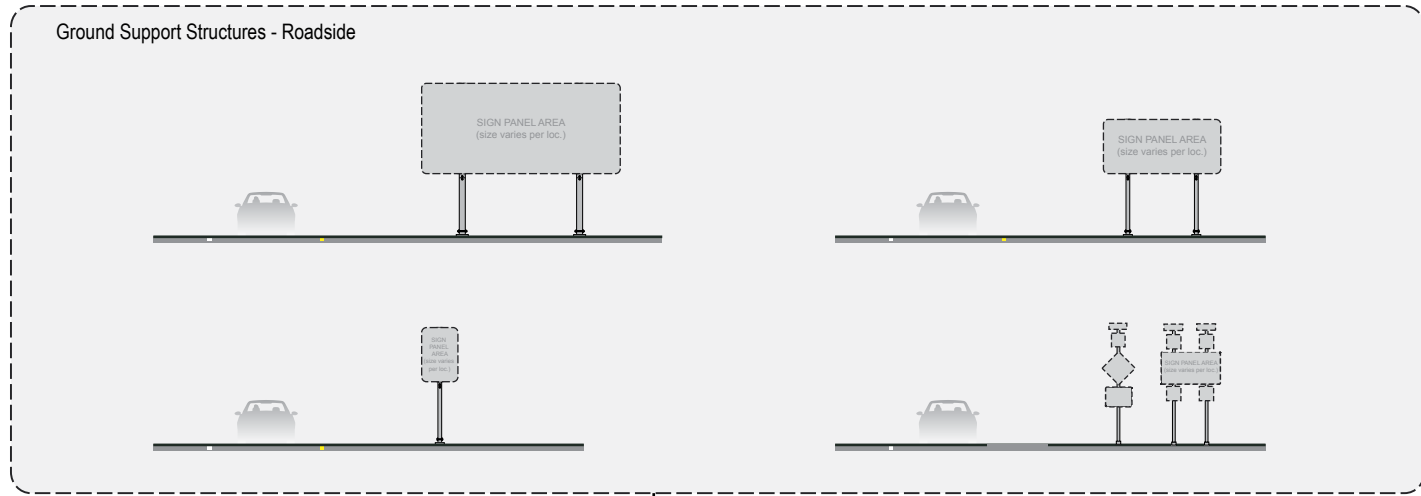

Figure 1.1.8e

DFW Wayfinding Sign Family: **Garage/Parking Areas - Vehicular**



***NOTE:**
 Typical Sign Panel & Support Structure Examples Only
 Sign panels and support structures shown here are for typical example purposes only and are provided as a general design reference for as-built DFW Roadway signage; for additional information/sign panel layouts/structure details/etc. see existing as-built documents

*Typical Sign Panel Examples

RECOMMENDED



S-SB-10 Vehicular Directional Panel - Roadside (13'-0" w x 6'-0" h)



S-NB-11 Vehicular Directional Panel - Roadside (12'-0" w x 6'-0" h)



C-11-GM04 Vehicular Directional Panel - Roadside (18'-6" w x 2'-6" h)



C-12-GM03 Vehicular Directional Panel - Roadside (16'-0" w x 8'-0" h)



C-14-GM02 Vehicular Directional Panel - Roadside (10'-6" w x 8'-6" h)



S-NB-7 Vehicular Directional Panel - Roadside (4'-0" w x 4'-0" h)



IT-NB-22 Vehicular Directional Panel - Roadside (3'-0" w x 5'-0" h)

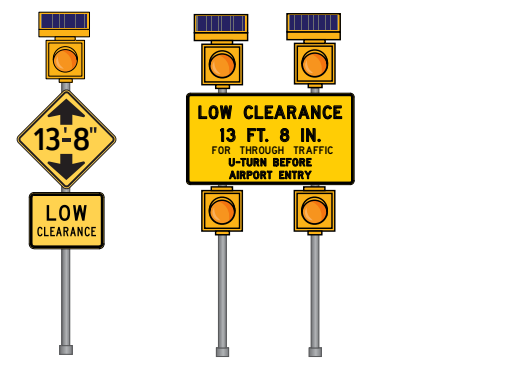

C-14-GM02 Vehicular Int. Prkwy TxDOT Standard Signs - Pole Mount

Figure 1.1.8e

DFW Wayfinding Sign Family: **Roadside Directional - Vehicular**

ILLUMINATION	SIGN TYPE	SIGN FUNCTION	MOUNTING METHOD	GENERAL DESCRIPTION & USE
REFLECTIVE	Large Overhead Support Structures: Span / Bridge	VARIABLES	SPAN / BRIDGE	Large Overhead Sign Support Structures (Typical) - Span and Bridge Mount

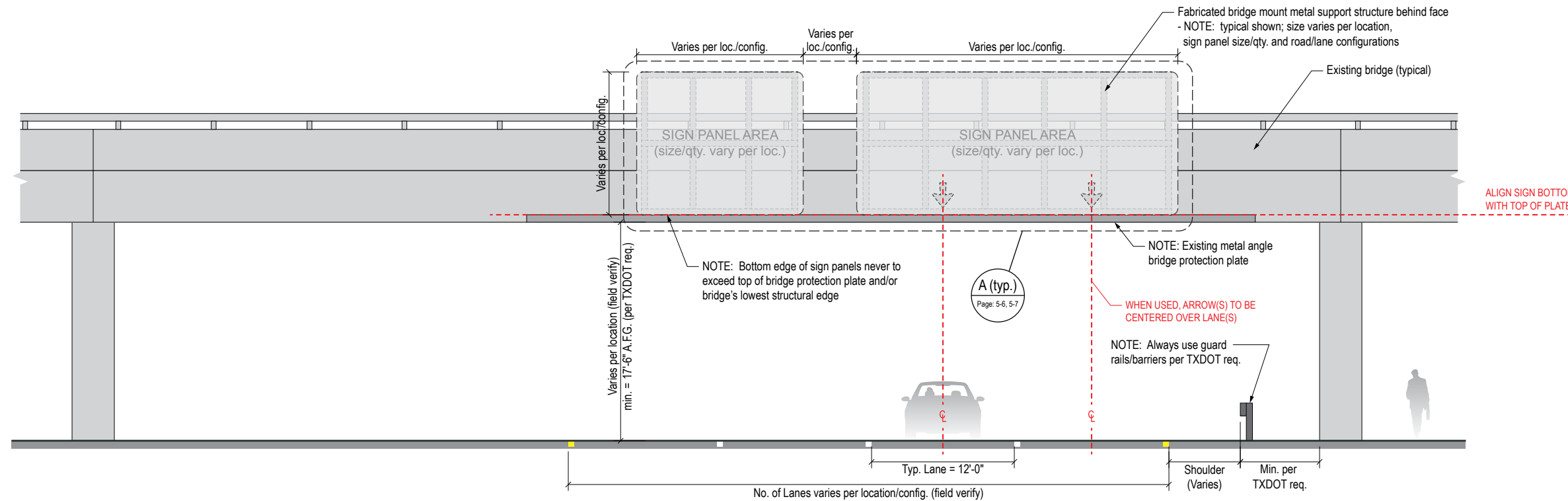

1 ELEVATION (TYPICAL) - Overhead Bridge Mount Structure
Scale: 3/32" = 1'-0"

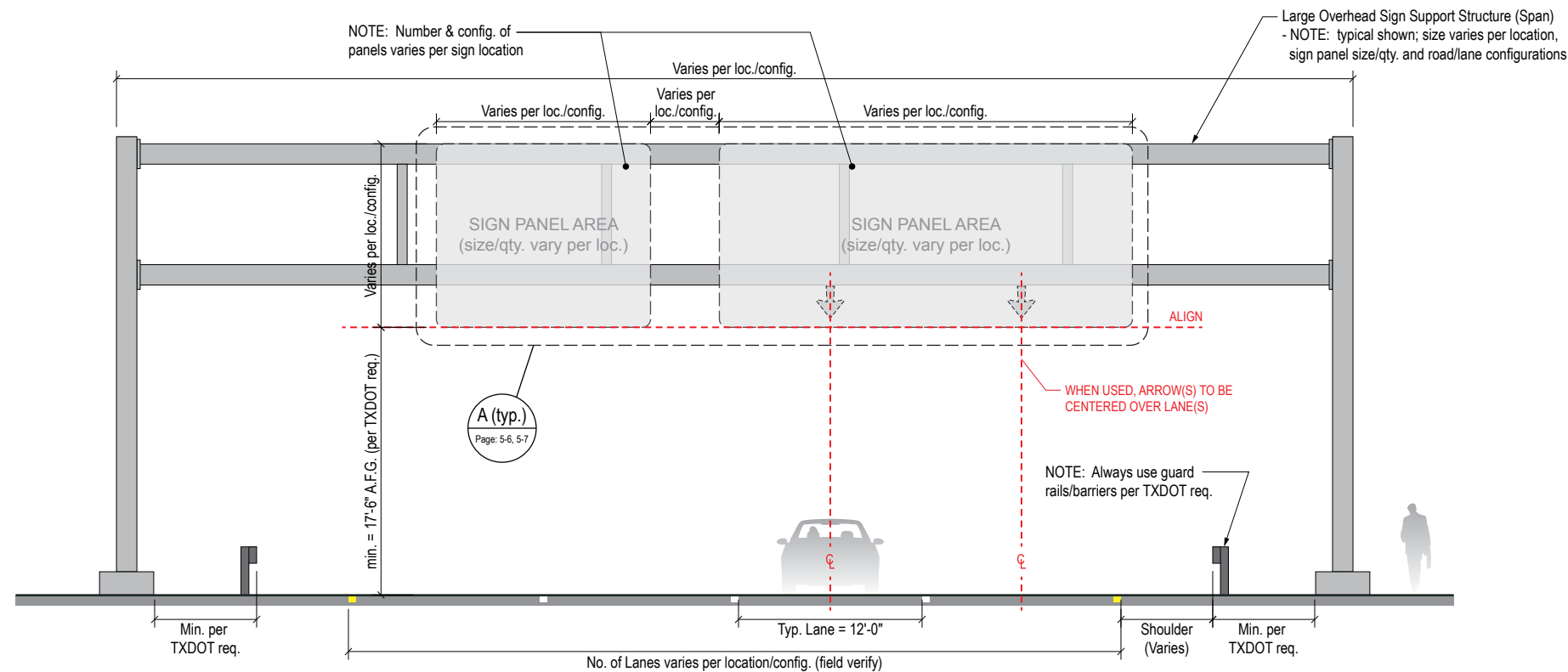

2 ELEVATION (TYPICAL) - Overhead Span Structure
Scale: 3/32" = 1'-0"

GENERAL NOTES

- All final design, engineering, and amount/sizing of structural sign support elements, material types/thicknesses, dimensions, and attachment methods shall be performed and approved by a licensed engineer to meet or exceed all applicable local and national codes.
- Final engineering, dimensions, materials, and fabrication are the responsibility of the Fabricator to ensure the highest quality fit and finish for all components of the completed product. All final detailing and specifications to be provided by the Fabricator within their final approved fabrication-ready shop drawings.
- Wherever dissimilar metals are in contact, always separate contact surfaces prior to assembly or installation with the necessary protective coatings/gaskets/washers to prevent galvanic corrosion.
- Final fabrication methods, quality and finish to be reviewed and approved by DFW Planning Department and wayfinding/architecture Design Consultants thru prototype reviews prior to final production run/installation processes (see Performance Specifications for details).
- Colors shown are for reference only, and are subject to the limitations of the printing process and/or variance of electronic RGB screen displays. Refer to color system swatches and/or final finish samples for accurate reference.
- Messages shown here are general placeholders only. See graphic message schedules for specific messaging by location and sign type.

ROADWAY SIGNAGE/STRUCTURES GENERAL NOTES

***NOTE:**
Typical Sign Panel and Support Structure Examples Only
Sign panels and support structures shown here are for typical example purposes only and are provided as a general design reference for as-built DFW Airport Roadway signage; for additional information/sign panel layouts/structure details, see existing as-built document reference list below

All signage and support structures used on DFW Airport roadways will comply with all regulations, design standards and requirements as shown in the latest edition of the MUTCD and TXDOT design manuals.

ILLUMINATION	SIGN TYPE	SIGN FUNCTION	MOUNTING METHOD	GENERAL DESCRIPTION & USE
REFLECTIVE	Large Overhead Support Structures: Cantilever	VARIABLES	CANTILEVER	Large Overhead Sign Support Structures (Typical) - Cantilever Mount

GENERAL NOTES

- All final design, engineering, and amount/sizing of structural sign support elements, material types/thicknesses, dimensions, and attachment methods shall be performed and approved by a licensed engineer to meet or exceed all applicable local and national codes.
- Final engineering, dimensions, materials, and fabrication are the responsibility of the Fabricator to ensure the highest quality fit and finish for all components of the completed product. All final detailing and specifications to be provided by the Fabricator within their final approved fabrication-ready shop drawings.
- Wherever dissimilar metals are in contact, always separate contact surfaces prior to assembly or installation with the necessary protective coatings/gaskets/washers to prevent galvanic corrosion.
- Final fabrication methods, quality and fit/finish to be reviewed and approved by DFW Planning Department and wayfinding/architecture Design Consultants thru prototype reviews prior to final production run/installation processes (see Performance Specifications for details).
- Colors shown are for reference only, and are subject to the limitations of the printing process and/or variance of electronic RGB screen displays. Refer to color system swatches and/or final finish samples for accurate reference.
- Messages shown here are general placeholders only. See graphic message schedules for specific messaging by location and sign type.

ROADWAY SIGNAGE/STRUCTURES GENERAL NOTES

***NOTE:**
Typical Sign Panel and Support Structure Examples Only
 Sign panels and support structures shown here are for typical example purposes only and are provided as a general design reference for as-built DFW Airport Roadway signage; for additional information/sign panel layouts/structure details, see existing as-built document reference list below

All signage and support structures used on DFW Airport roadways will comply with all regulations, design standards and requirements as shown in the latest edition of the MUTCD and TXDOT design manuals.

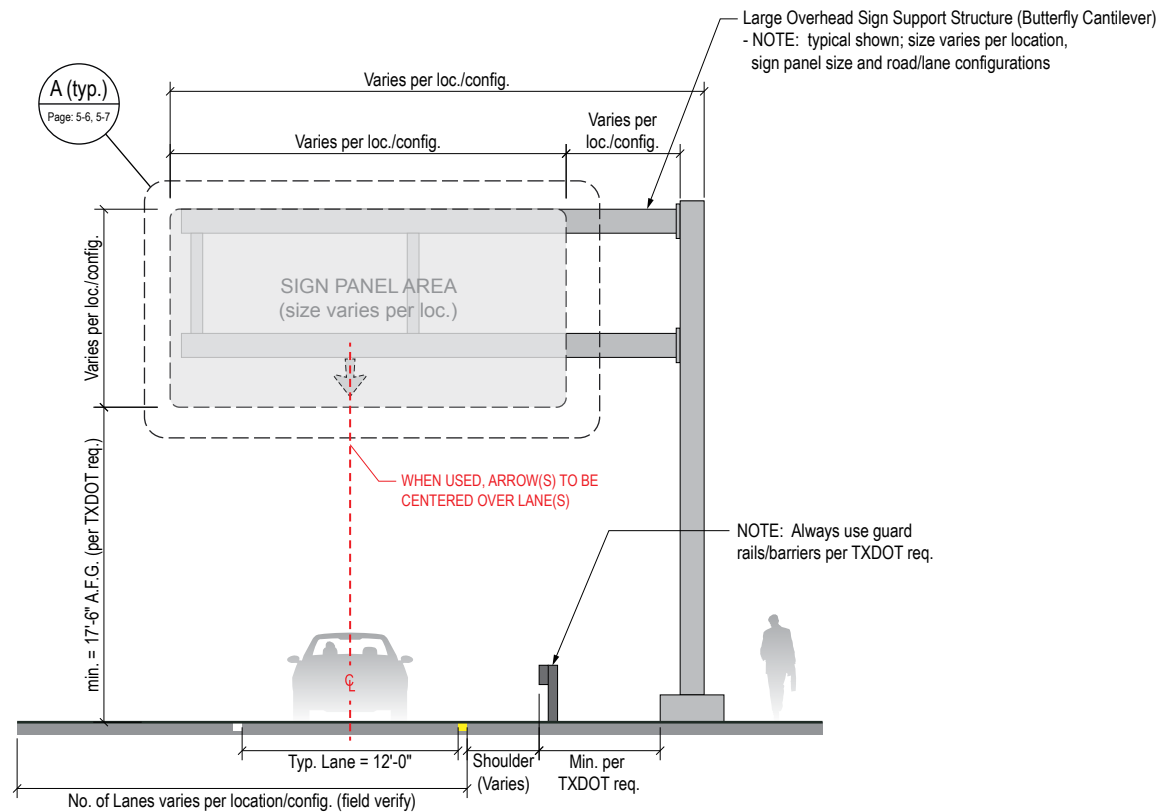

1 ELEVATION (TYPICAL) - Overhead Cantilever Structure
 Scale: 3/32" = 1'-0"

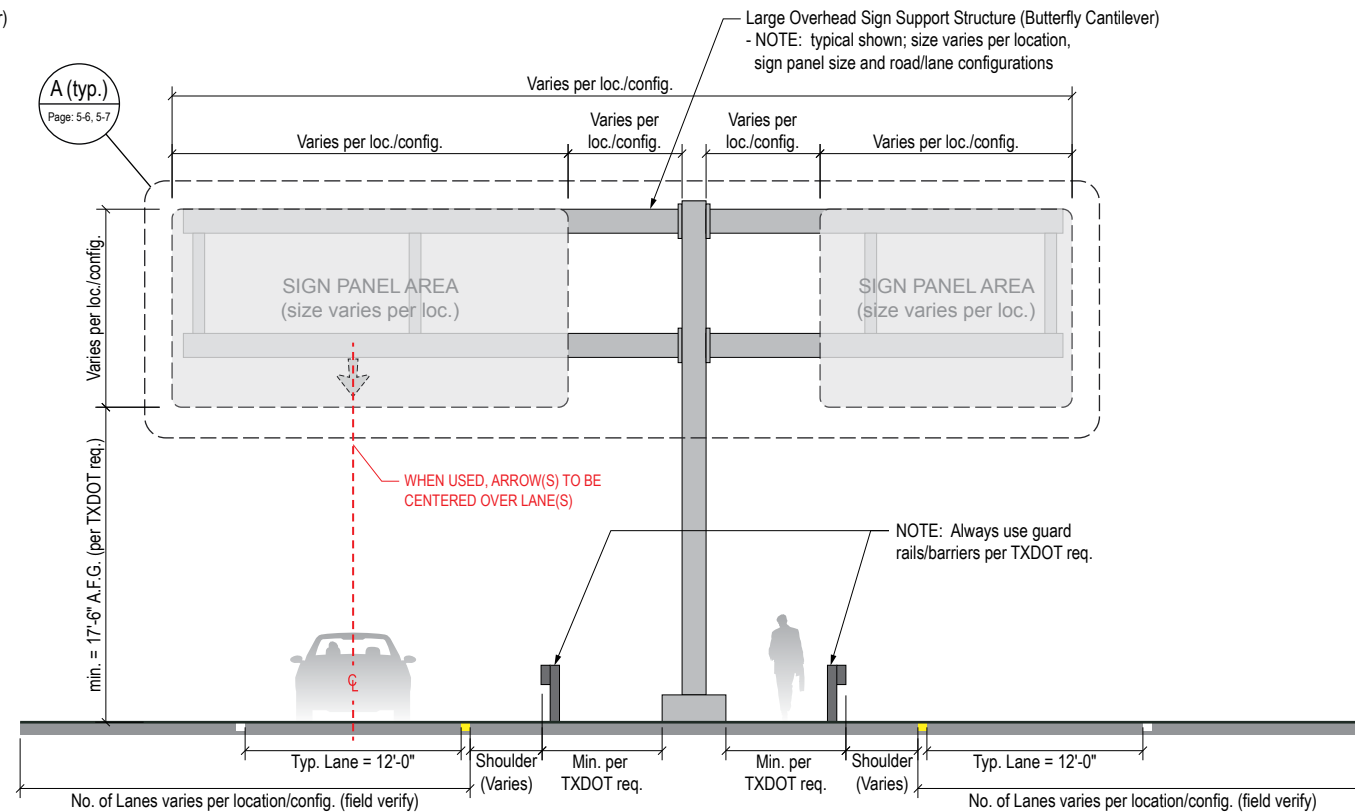

2 ELEVATION (TYPICAL) - Overhead Butterfly Cantilever Structure
 Scale: 3/32" = 1'-0"

ILLUMINATION	SIGN TYPE	SIGN FUNCTION	MOUNTING METHOD	GENERAL DESCRIPTION & USE
REFLECTIVE	New (2017) Large Overhead Sign Panels (Typical)	VARIABLES	SPAN / BRIDGE / CANTILEVER	Large Overhead Sign Panels - Face Layouts (Typical)

Typical Large Overhead Sign Structures Examples

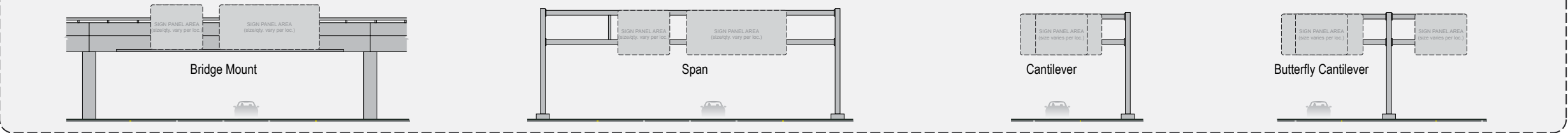

*Typical Sign Panel Examples Only

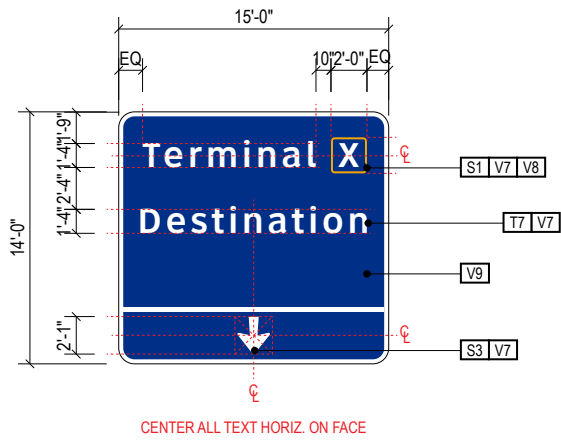

A1 FACE LAYOUT: 4-DR.01 (Typical)
Scale: 3/32" = 1'-0"
ALIGN

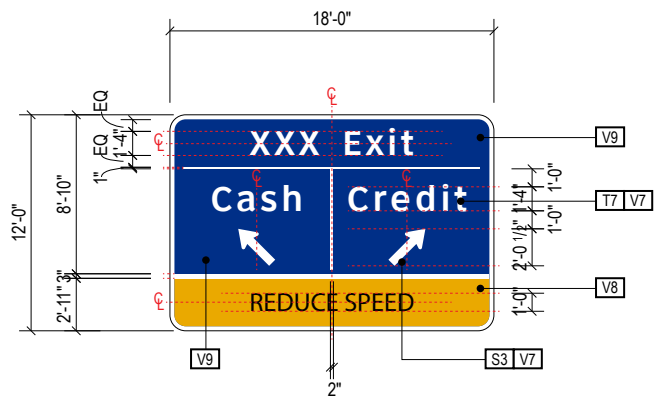

A3 FACE LAYOUT: 4-DR.05 (Typical)
Scale: 3/32" = 1'-0"

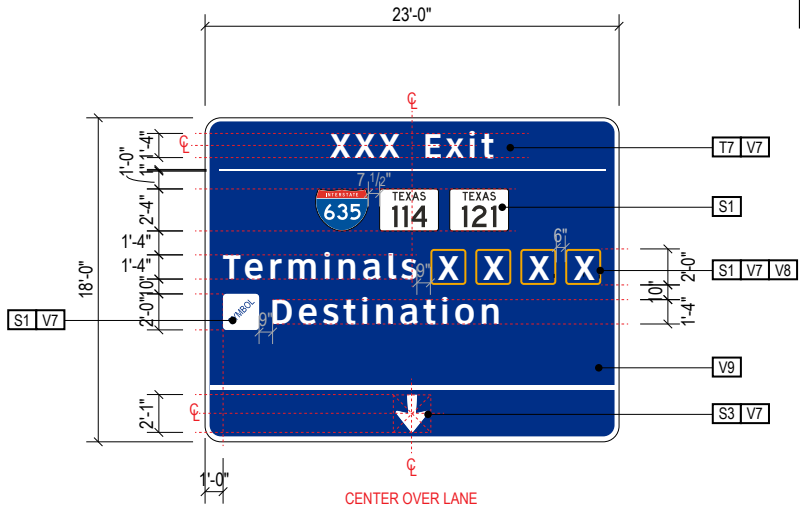

A5 FACE LAYOUT: 4-DR.11 (Typical)
Scale: 3/32" = 1'-0"

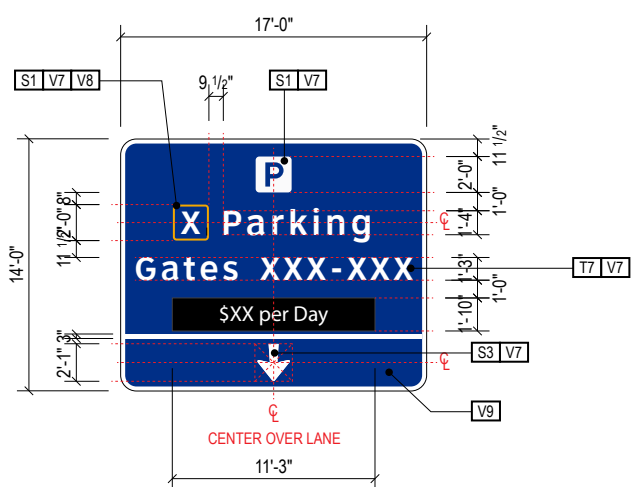

A2 FACE LAYOUT: 4-DR.02 (Typical)
Scale: 3/32" = 1'-0"

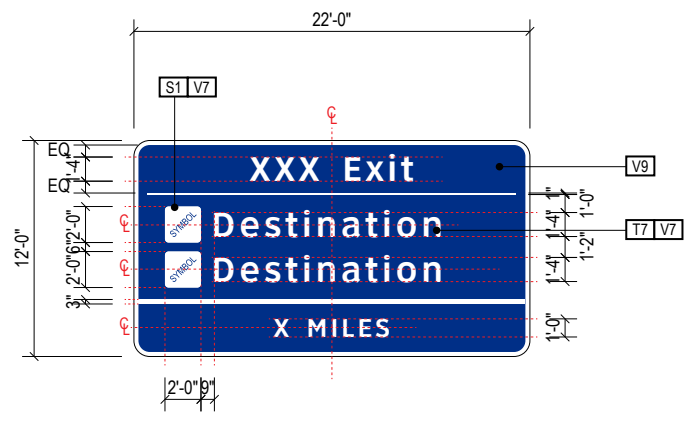

A4 FACE LAYOUT: 4-DR.06 (Typical)
Scale: 3/32" = 1'-0"

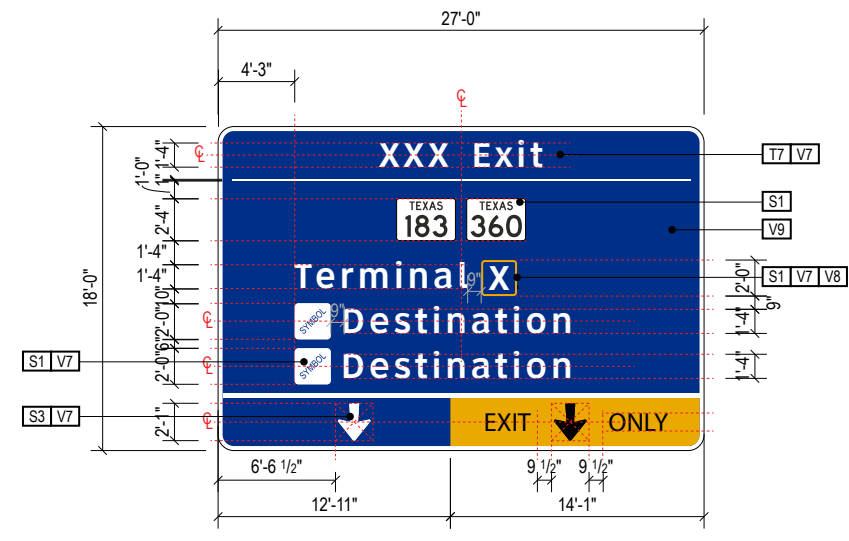

A6 FACE LAYOUT: 4-DR.12 (Typical)
Scale: 3/32" = 1'-0"

GENERAL NOTES

- All final design, engineering, and amount/sizing of structural sign support elements, material types/thicknesses, dimensions, and attachment methods shall be performed and approved by a licensed engineer to meet or exceed all applicable local and national codes.
- Final engineering, dimensions, materials, and fabrication are the responsibility of the Fabricator to ensure the highest quality fit and finish for all components of the completed product. All final detailing and specifications to be provided by the Fabricator within their final approved fabrication-ready shop drawings.
- Wherever dissimilar metals are in contact, always separate contact surfaces prior to assembly or installation with the necessary protective coatings/gaskets/washers to prevent galvanic corrosion.
- Final fabrication methods, quality and fit/finish to be reviewed and approved by DFW Planning Department and wayfinding/architecture Design Consultants thru prototype reviews prior to final production run/installation processes (see Performance Specifications for details).
- Colors shown are for reference only, and are subject to the limitations of the printing process and/or variance of electronic RGB screen displays. Refer to color system swatches and/or final finish samples for accurate reference.
- Messages shown here are general placeholders only. See graphic message schedules for specific messaging by location and sign type.

ROADWAY SIGNAGE/STRUCTURES GENERAL NOTES

***NOTE:**
Typical Sign Panel and Support Structure Examples Only
Sign panels and support structures shown here are for typical example purposes only and are provided as a general design reference for as-built DFW Airport Roadway signage; for additional information/sign panel layouts/structure details, see existing as-built document reference list below

All signage and support structures used on DFW Airport roadways will comply with all regulations, design standards and requirements as shown in the latest edition of the MUTCD and TXDOT design manuals.

GRAPHICS / COLORS / DECORATION NOTES

- T7** Typeface: font = Clearview Hwy 5-W
- S1** Universal Symbols: AIGA/TXDOT style symbol artwork
- S3** Veh. Arrow(s): use only official MUTCD/TXDOT arrow art
- VINYL (FILM):
- V7** White: 3M 4090 DG3 White (Reflective)
- V8** Yellow: 3M 4091 DG3 Yellow (Reflective)
- V9** Blue: 3M 4095 DG3 Blue (Reflective)

ILLUMINATION	SIGN TYPE	SIGN FUNCTION	MOUNTING METHOD	GENERAL DESCRIPTION & USE
REFLECTIVE	Large Overhead Sign Panels (Typical)	VARIES	SPAN / BRIDGE / CANTILEVER	Large Overhead Sign Panels - Face Layouts (Typical)

Typical Large Overhead Sign Structures Examples

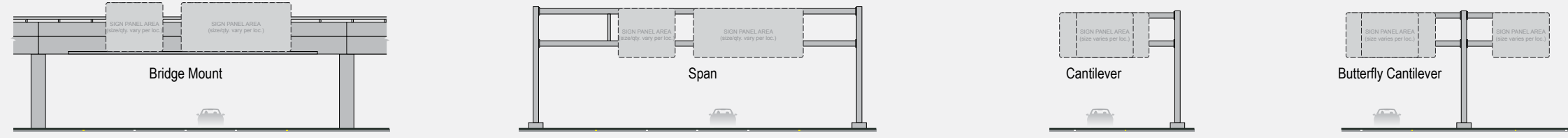

*Typical Sign Panel Examples Only

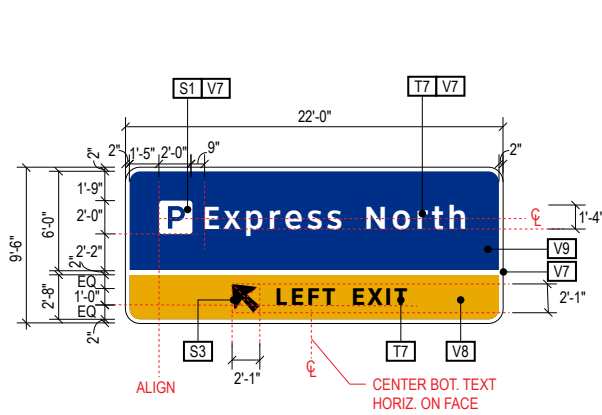

S-NB-1 Vehicular Directional Panel - Cantilever (22'-0" w x 9'-6" h)

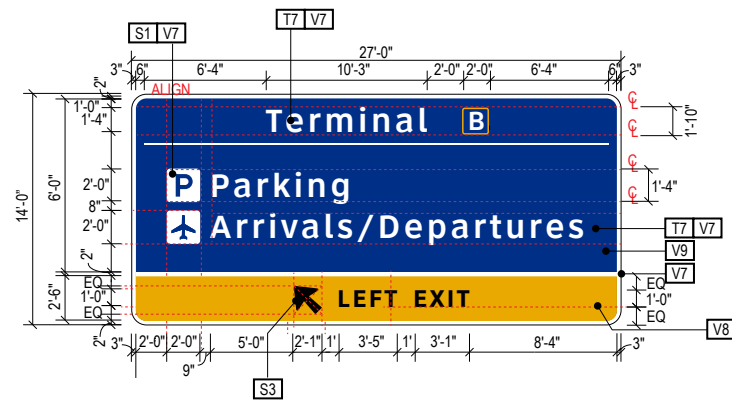

S-NB-3 Vehicular Directional Panel - Two Line Terminal (27'-0" w x 14'-0" h)

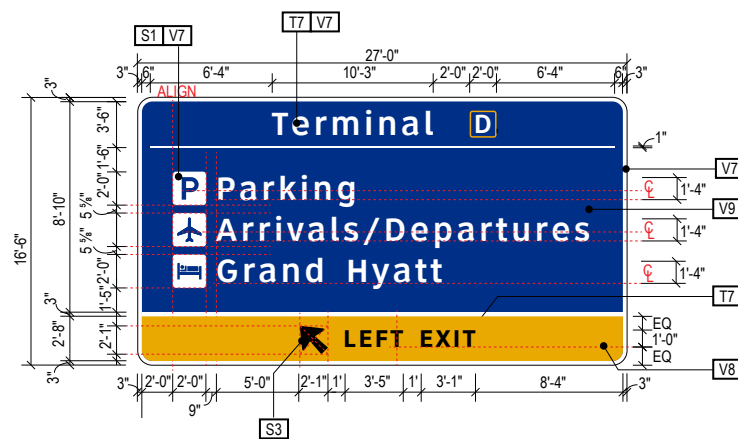
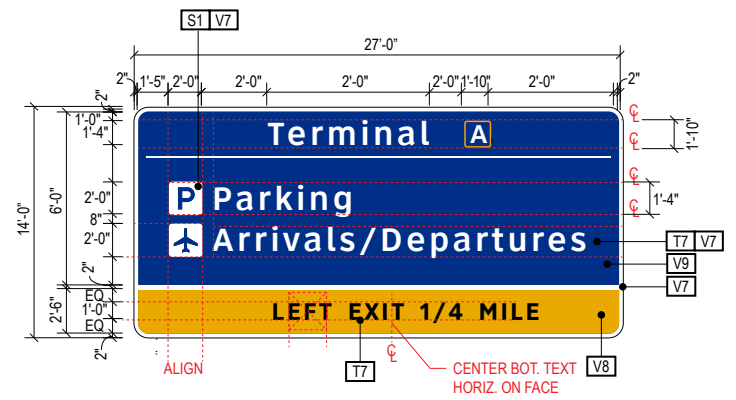

S-NB-2 Vehicular Directional Panel - Three Line Terminal (27'-0" w x 16'-6" h)

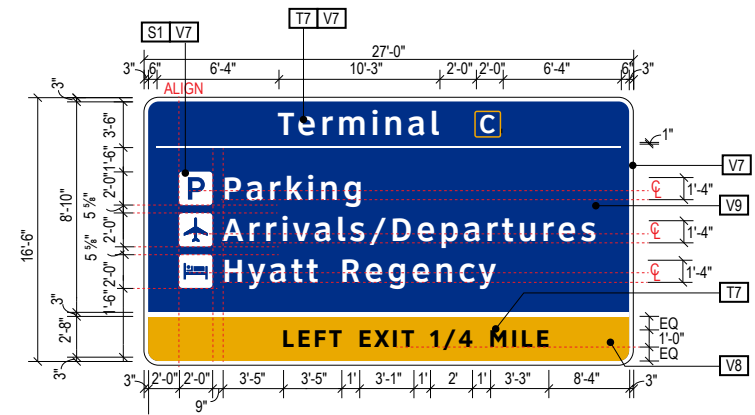

GENERAL NOTES

- All final design, engineering, and amount/sizing of structural sign support elements, material types/thicknesses, dimensions, and attachment methods shall be performed and approved by a licensed engineer to meet or exceed all applicable local and national codes.
- Final engineering, dimensions, materials, and fabrication are the responsibility of the Fabricator to ensure the highest quality fit and finish for all components of the completed product. All final detailing and specifications to be provided by the Fabricator within their final approved fabrication-ready shop drawings.
- Wherever dissimilar metals are in contact, always separate contact surfaces prior to assembly or installation with the necessary protective coatings/gaskets/washers to prevent galvanic corrosion.
- Final fabrication methods, quality and fit/finish to be reviewed and approved by DFW Planning Department and wayfinding/architecture Design Consultants thru prototype reviews prior to final production run/installation processes (see Performance Specifications for details).
- Colors shown are for reference only, and are subject to the limitations of the printing process and/or variance of electronic RGB screen displays. Refer to color system swatches and/or final finish samples for accurate reference.
- Messages shown here are general placeholders only. See graphic message schedules for specific messaging by location and sign type.

ROADWAY SIGNAGE/STRUCTURES GENERAL NOTES

***NOTE:**
Typical Sign Panel and Support Structure Examples Only
Sign panels and support structures shown here are for typical example purposes only and are provided as a general design reference for as-built DFW Airport Roadway signage; for additional information/sign panel layouts/structure details, see existing as-built document reference list below

All signage and support structures used on DFW Airport roadways will comply with all regulations, design standards and requirements as shown in the latest edition of the MUTCD and TXDOT design manuals.

GRAPHICS / COLORS / DECORATION NOTES

- T7 Typeface: font = Clearview Hwy 5-W
- S1 Universal Symbols: AIGA/TXDOT style symbol artwork
- S3 Veh. Arrow(s): use only official MUTCD/TXDOT arrow art
- VINYL (FILM):
- V7 White: 3M 4090 DG3 White (Reflective)
- V8 Yellow: 3M 4091 DG3 Yellow (Reflective)
- V9 Blue: 3M 4095 DG3 Blue (Reflective)

WARNING:

This record contains Sensitive Security Information that is controlled under 49 CFR parts 15 and 1520. No part of this record may be disclosed to persons with a "need to know," as defined in 49 CFR parts 15 and 1520, except with the written permission of the Administrator of the Transportation Security Administration or the Secretary of Transportation. Unauthorized release may result in civil penalty or other action. For U.S. government agencies, public disclosure is governed by 5 U.S.C. 552 and 49 CFR parts 15 and 1520.

ILLUMINATION	SIGN TYPE	SIGN FUNCTION	MOUNTING METHOD	GENERAL DESCRIPTION & USE
REFLECTIVE	Roadside Support Structures	VARIES	ROADSIDE POST MOUNT	Roadside Sign Support Structures (Typical)

GENERAL NOTES

- All final design, engineering, and amount/sizing of structural sign support elements, material types/thicknesses, dimensions, and attachment methods shall be performed and approved by a licensed engineer to meet or exceed all applicable local and national codes.
- Final engineering, dimensions, materials, and fabrication are the responsibility of the Fabricator to ensure the highest quality fit and finish for all components of the completed product. All final detailing and specifications to be provided by the Fabricator within their final approved fabrication-ready shop drawings.
- Wherever dissimilar metals are in contact, always separate contact surfaces prior to assembly or installation with the necessary protective coatings/gaskets/washers to prevent galvanic corrosion.
- Final fabrication methods, quality and fit/finish to be reviewed and approved by DFW Planning Department and wayfinding/architecture Design Consultants thru prototype reviews prior to final production run/installation processes (see Performance Specifications for details).
- Colors shown are for reference only, and are subject to the limitations of the printing process and/or variance of electronic RGB screen displays. Refer to color system swatches and/or final finish samples for accurate reference.
- Messages shown here are general placeholders only. See graphic message schedules for specific messaging by location and sign type.

ROADWAY SIGNAGE/STRUCTURES GENERAL NOTES

***NOTE:**
Typical Sign Panel and Support Structure Examples Only
 Sign panels and support structures shown here are for typical example purposes only and are provided as a general design reference for as-built DFW Airport Roadway signage; for additional information/sign panel layouts/structure details, see existing as-built document reference list below

All signage and support structures used on DFW Airport roadways will comply with all regulations, design standards and requirements as shown in the latest edition of the MUTCD and TXDOT design manuals.

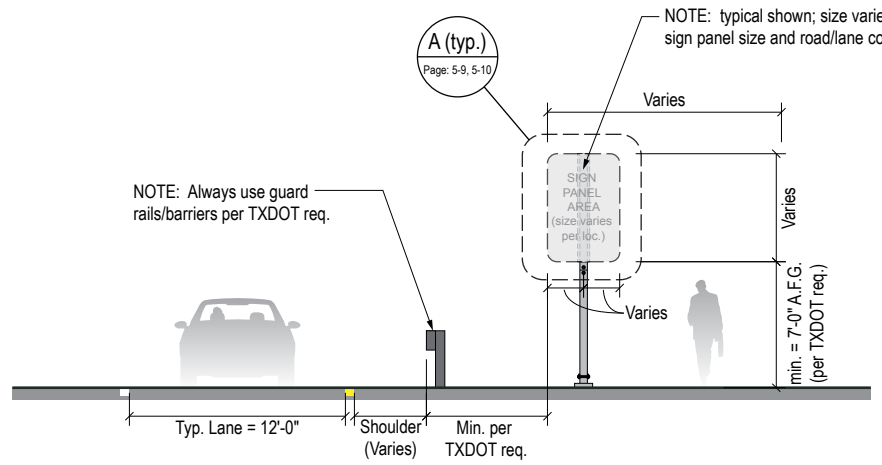

1 ELEVATION (TYPICAL) - Roadside Structure: Small w/ One Post
 Scale: 3/32" = 1'-0"

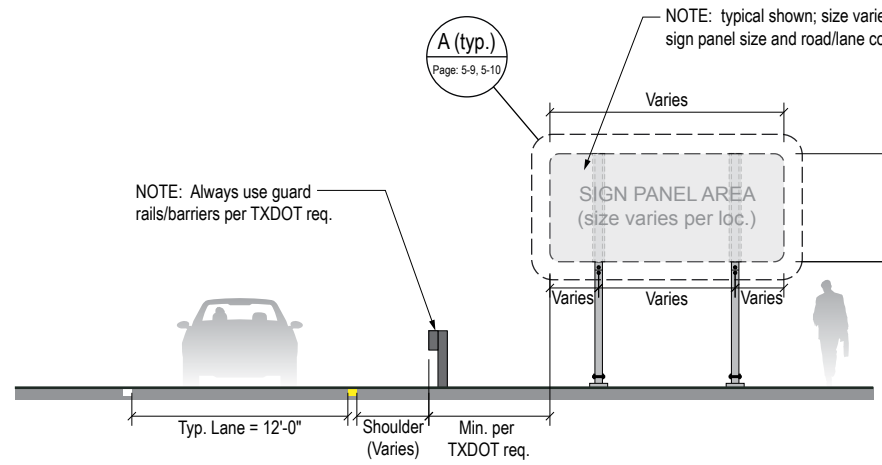

2 ELEVATION (TYPICAL) - Roadside Structure: Small w/ Two Posts
 Scale: 3/32" = 1'-0"

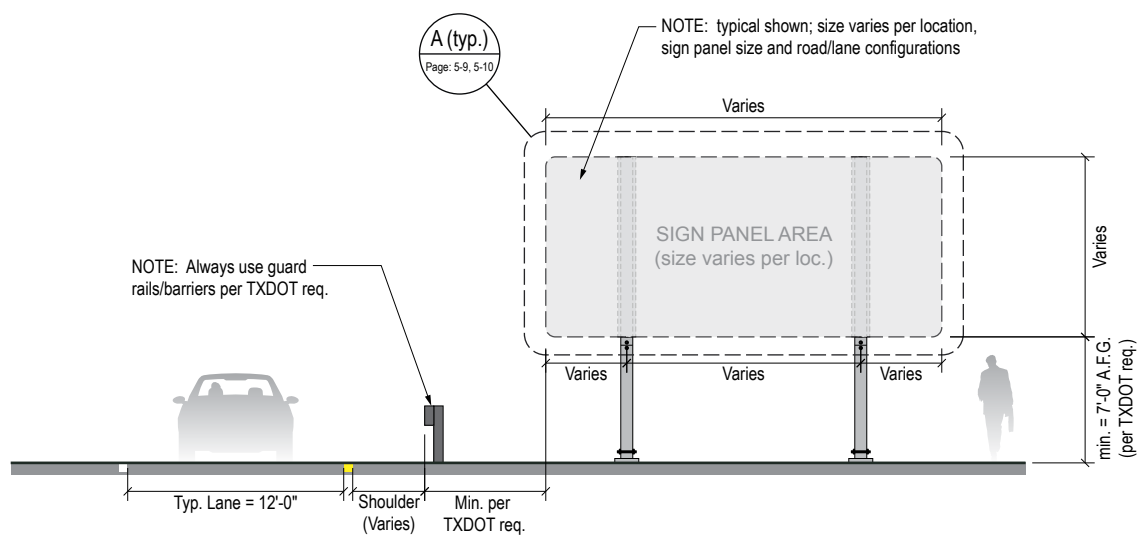

3 ELEVATION (TYPICAL) - Roadside Structure: Large w/ Two Posts
 Scale: 3/32" = 1'-0"

ILLUMINATION	SIGN TYPE	SIGN FUNCTION	MOUNTING METHOD	GENERAL DESCRIPTION & USE
REFLECTIVE	New (2017) Roadside Sign Panels (Typical)	VARIES	ROADSIDE POST MOUNT	Roadside Sign Panels - Face Layouts (Typical)

Typical Roadside Sign Structures Examples

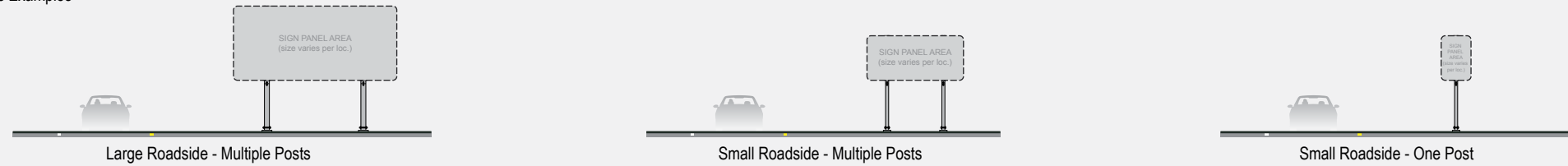

*Typical Sign Panel Examples Only

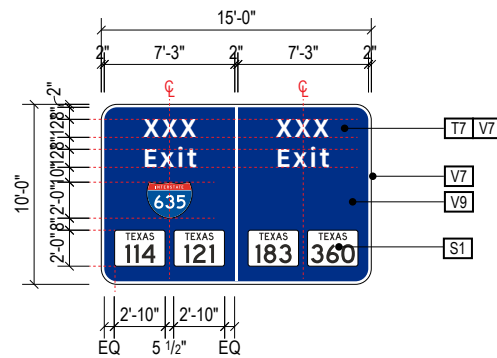

A1 FACE LAYOUT: 4-DR.30
Scale: 3/32" = 1'-0"

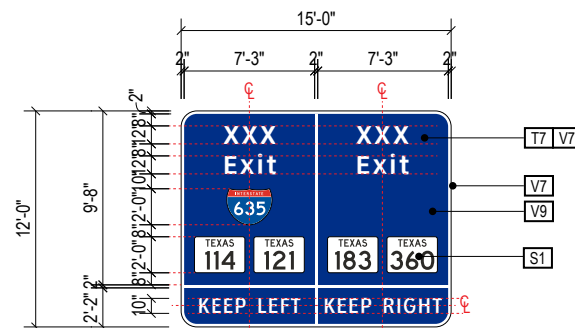

A2 FACE LAYOUT: 4-DR.31
Scale: 3/36" = 1'-0"

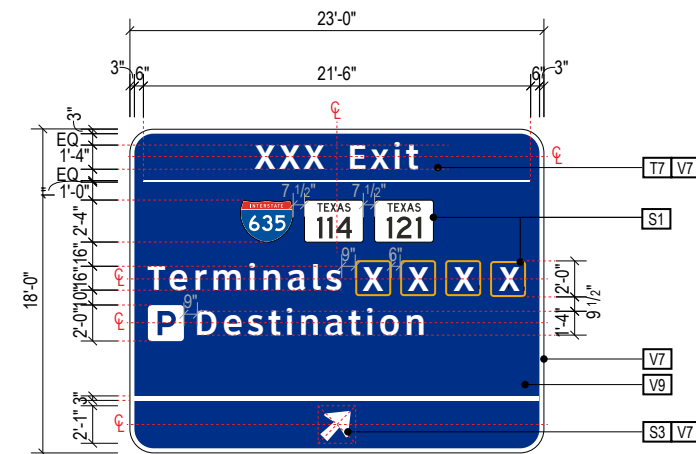

A3 FACE LAYOUT: 4-DR.35
Scale: 3/32" = 1'-0"

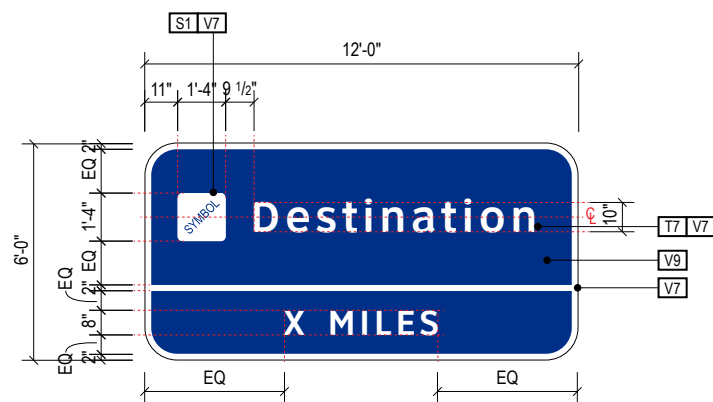

A4 FACE LAYOUT - *Typical Example (S-NB-11 shown)
Scale: 3/16" = 1'-0"

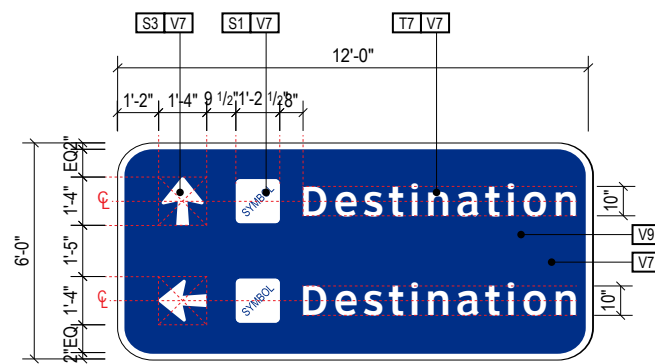

A5 FACE LAYOUT - *Typical Example (S-NB-11 shown)
Scale: 3/16" = 1'-0"

GENERAL NOTES

- All final design, engineering, and amount/sizing of structural sign support elements, material types/thicknesses, dimensions, and attachment methods shall be performed and approved by a licensed engineer to meet or exceed all applicable local and national codes.
- Final engineering, dimensions, materials, and fabrication are the responsibility of the Fabricator to ensure the highest quality fit and finish for all components of the completed product. All final detailing and specifications to be provided by the Fabricator within their final approved fabrication-ready shop drawings.
- Wherever dissimilar metals are in contact, always separate contact surfaces prior to assembly or installation with the necessary protective coatings/gaskets/washers to prevent galvanic corrosion.
- Final fabrication methods, quality and fit/finish to be reviewed and approved by DFW Planning Department and wayfinding/architecture Design Consultants thru prototype reviews prior to final production run/installation processes (see Performance Specifications for details).
- Colors shown are for reference only, and are subject to the limitations of the printing process and/or variance of electronic RGB screen displays. Refer to color system swatches and/or final finish samples for accurate reference.
- Messages shown here are general placeholders only. See graphic message schedules for specific messaging by location and sign type.

ROADWAY SIGNAGE/STRUCTURES GENERAL NOTES

***NOTE:**
Typical Sign Panel and Support Structure Examples Only
Sign panels and support structures shown here are for typical example purposes only and are provided as a general design reference for as-built DFW Airport Roadway signage; for additional information/sign panel layouts/structure details, see existing as-built document reference list below

All signage and support structures used on DFW Airport roadways will comply with all regulations, design standards and requirements as shown in the latest edition of the MUTCD and TXDOT design manuals.

GRAPHICS / COLORS / DECORATION NOTES

- T7** Typeface: font = Clearview Hwy 5-W
 - S1** Universal Symbols: AIGA/TXDOT style symbol artwork
 - S3** Veh. Arrow(s): use only official MUTCD/TXDOT arrow art
- VINYL (FILM):
- V7** White: 3M 4090 DG3 White (Reflective)
 - V8** Yellow: 3M 4091 DG3 Yellow (Reflective)
 - V9** Blue: 3M 4095 DG3 Blue (Reflective)

WARNING:

This record contains Sensitive Security Information that is controlled under 49 CFR parts 15 and 1520. No part of this record may be disclosed to persons with a "need to know," as defined in 49 CFR parts 15 and 1520, except with the written permission of the Administrator of the Transportation Security Administration or the Secretary of Transportation. Unauthorized release may result in civil penalty or other action. For U.S. government agencies, public disclosure is governed by 5 U.S.C. 552 and 49 CFR parts 15 and 1520.

ILLUMINATION	SIGN TYPE	SIGN FUNCTION	MOUNTING METHOD	GENERAL DESCRIPTION & USE
REFLECTIVE	Roadside Sign Panels (Typical)	VARIES	ROADSIDE POST MOUNT	Roadside Sign Panels - Face Layouts (Typical)

Typical Roadside Sign Structures Examples

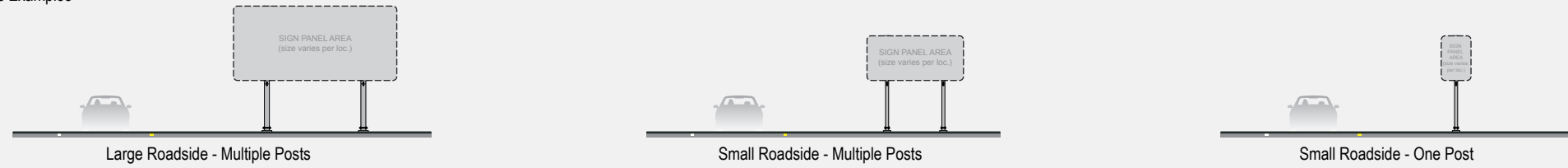

*Typical Sign Panel Examples Only

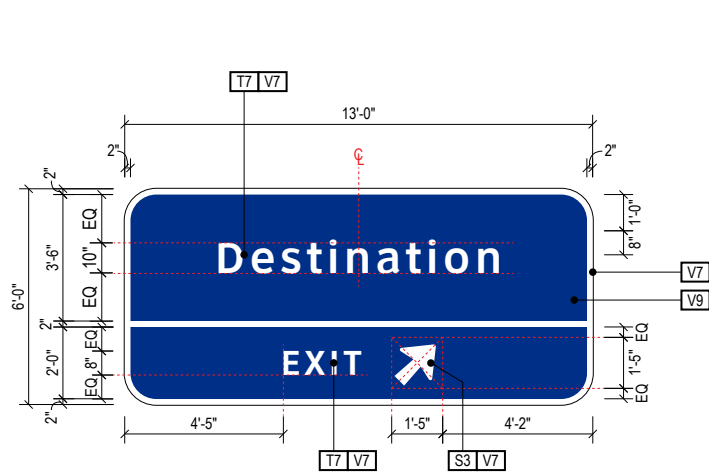

A6 FACE LAYOUT - *Typical Example (S-SB-10 shown)
Scale: 3/16" = 1'-0"

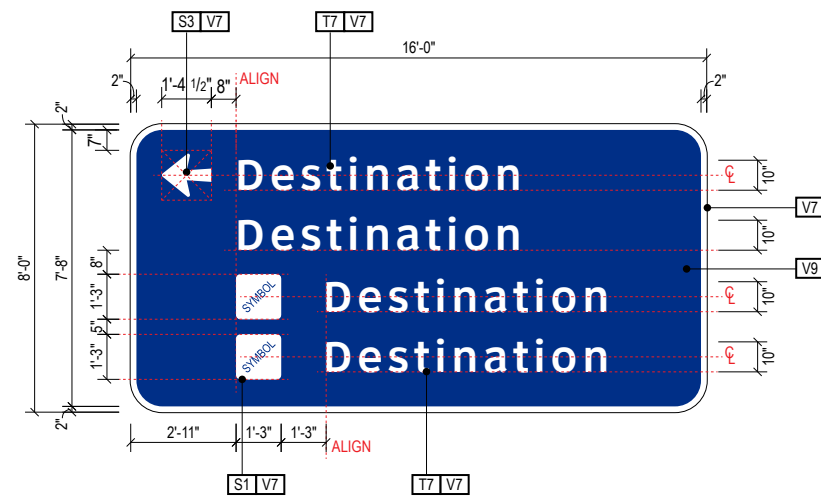

A8 FACE LAYOUT - *Typical Example (C-12-GM03 shown)
Scale: 3/16" = 1'-0"

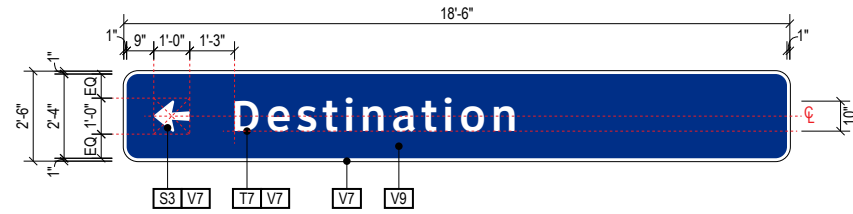

A9 FACE LAYOUT - *Typical Example (C-11-GM04 shown)
Scale: 3/16" = 1'-0"

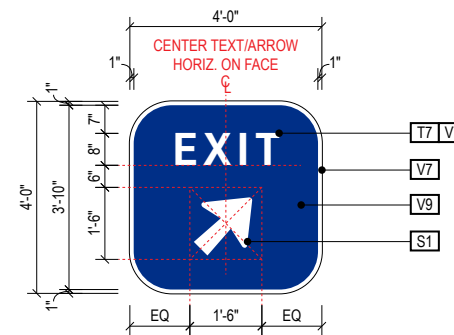

A10 FACE LAYOUT - *Typical Example (S-NB-7 shown)
Scale: 1/4" = 1'-0"



A7 FACE LAYOUT - *Typical Example (C-14-GM02 shown)
Scale: 3/16" = 1'-0"

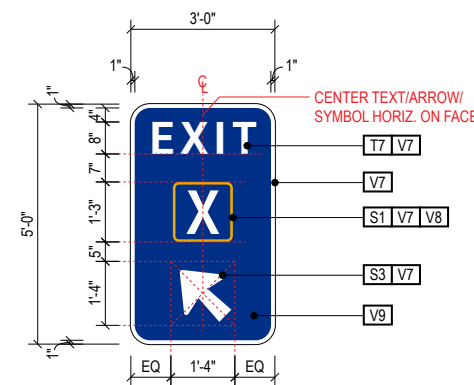

A11 FACE LAYOUT - *Typical Example (IT-NB-22 shown)
Scale: 1/4" = 1'-0"

GENERAL NOTES

- All final design, engineering, and amount/sizing of structural sign support elements, material types/thicknesses, dimensions, and attachment methods shall be performed and approved by a licensed engineer to meet or exceed all applicable local and national codes.
- Final engineering, dimensions, materials, and fabrication are the responsibility of the Fabricator to ensure the highest quality fit and finish for all components of the completed product. All final detailing and specifications to be provided by the Fabricator within their final approved fabrication-ready shop drawings.
- Wherever dissimilar metals are in contact, always separate contact surfaces prior to assembly or installation with the necessary protective coatings/gaskets/washers to prevent galvanic corrosion.
- Final fabrication methods, quality and fit/finish to be reviewed and approved by DFW Planning Department and wayfinding/architecture Design Consultants thru prototype reviews prior to final production run/installation processes (see Performance Specifications for details).
- Colors shown are for reference only, and are subject to the limitations of the printing process and/or variance of electronic RGB screen displays. Refer to color system swatches and/or final finish samples for accurate reference.
- Messages shown here are general placeholders only. See graphic message schedules for specific messaging by location and sign type.

ROADWAY SIGNAGE/STRUCTURES GENERAL NOTES

***NOTE:**
Typical Sign Panel and Support Structure Examples Only
Sign panels and support structures shown here are for typical example purposes only and are provided as a general design reference for as-built DFW Airport Roadway signage; for additional information/sign panel layouts/structure details, see existing as-built document reference list below

All signage and support structures used on DFW Airport roadways will comply with all regulations, design standards and requirements as shown in the latest edition of the MUTCD and TXDOT design manuals.

GRAPHICS / COLORS / DECORATION NOTES

- T7** Typeface: font = Clearview Hwy 5-W
- S1** Universal Symbols: AIGA/TXDOT style symbol artwork
- S3** Veh. Arrow(s): use only official MUTCD/TXDOT arrow art
- VINYL (FILM):
- V7** White: 3M 4090 DG3 White (Reflective)
- V8** Yellow: 3M 4091 DG3 Yellow (Reflective)
- V9** Blue: 3M 4095 DG3 Blue (Reflective)

WARNING:

This record contains Sensitive Security Information that is controlled under 49 CFR parts 15 and 1520. No part of this record may be disclosed to persons with a "need to know," as defined in 49 CFR parts 15 and 1520, except with the written permission of the Administrator of the Transportation Security Administration or the Secretary of Transportation. Unauthorized release may result in civil penalty or other action. For U.S. government agencies, public disclosure is governed by 5 U.S.C. 552 and 49 CFR parts 15 and 1520.

ILLUMINATION	SIGN TYPE	SIGN FUNCTION	MOUNTING METHOD	GENERAL DESCRIPTION & USE
REFLECTIVE	Control Plaza Sign / Pavement Markings	Varies	Wall Mounted / Pavement Markings	Control Plaza Sign / Pavement Markings

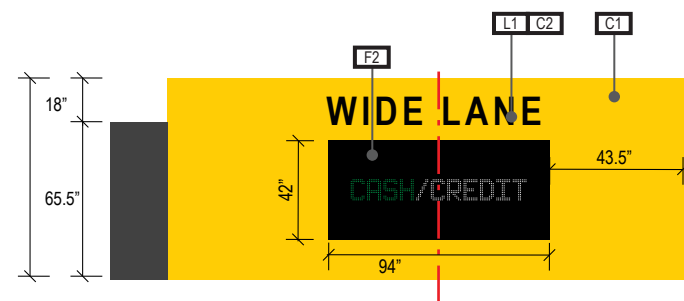

A FACE LAYOUT
Scale: NTS

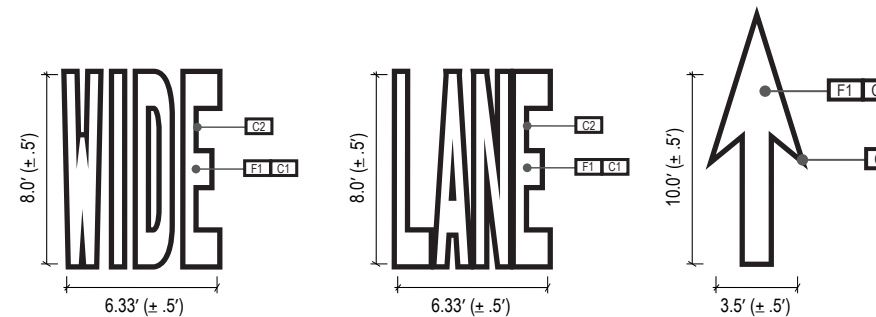

1 PAVEMENT MARKINGS
Scale: NTS

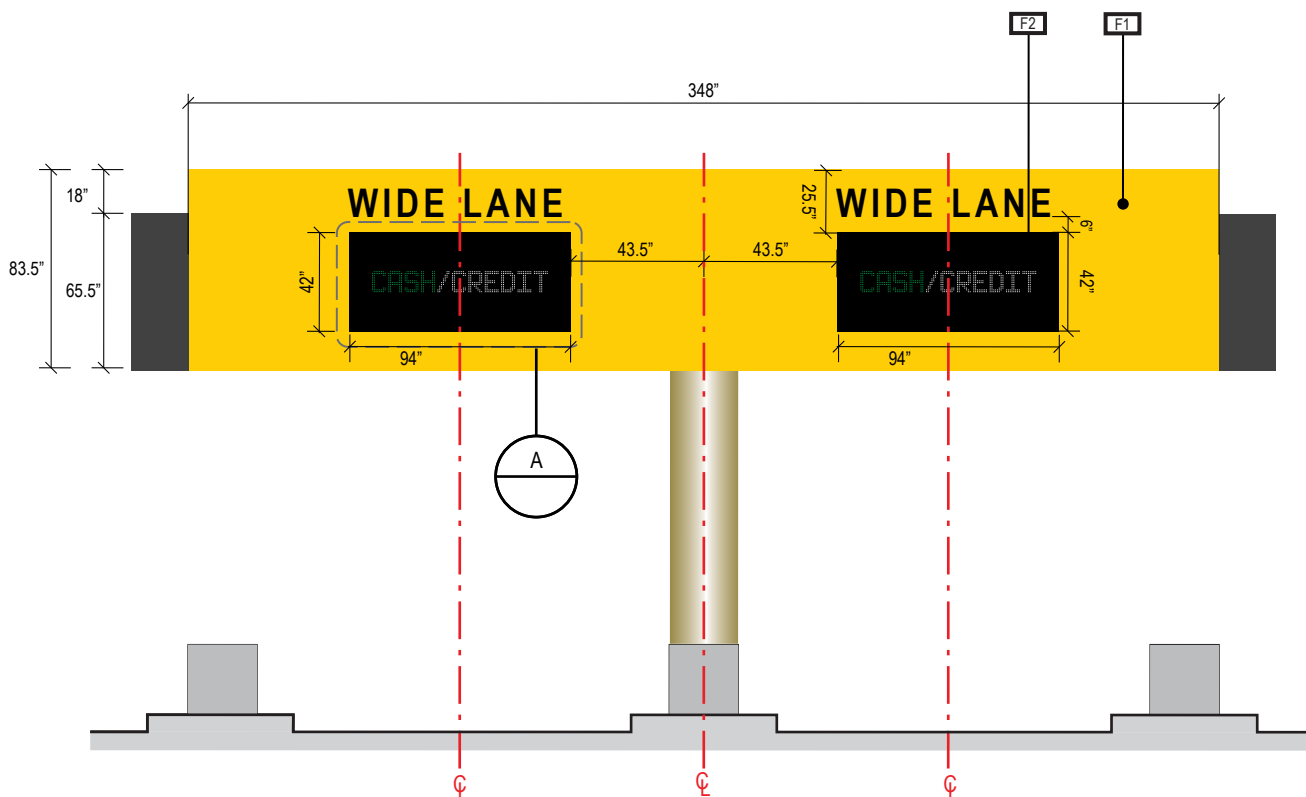

2 CONTROL PLAZA
Scale: NTS

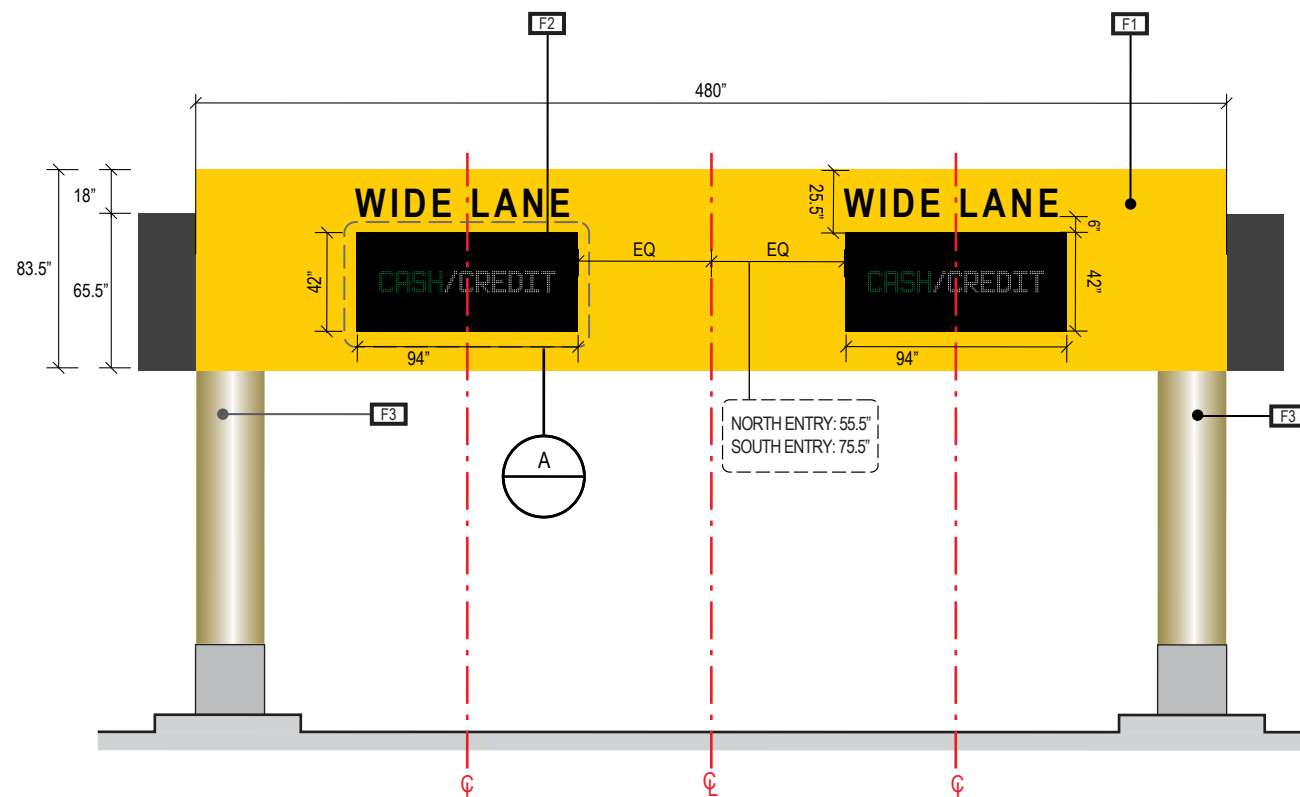

3 CONTROL PLAZA
Scale: NTS

GENERAL NOTES

- All final design, engineering & amount/sizing of structural sign support elements, material types/thicknesses, dimensions and attachment methods shall be performed and approved by a licensed engineer to meet or exceed all applicable local and national codes.
- Final engineering, dimensions, materials and fabrication are the responsibility of the Contractor/Fabricator/Installer to ensure the highest quality fit and finish for all components of the completed product. All final detailing and specifications to be provided by the Contractor/Fabricator/Installer within their final approved fabrication-ready shop drawings.
- Wherever dissimilar metals are in contact, always separate contact surfaces prior to assembly or installation with the necessary protective coatings/gaskets/washers to prevent galvanic corrosion.
- Colors shown are for reference only, and are subject to the limitations of the printing process and / or variance of electronic RGB screen displays. Refer to color system swatches and/or final finish samples for accurate reference.
- Messages shown here are typical placeholders only.
- All dimensions are approximate, where necessary, field verify for accuracy.

FABRICATION NOTES (GENERAL DESIGN INTENT)

- F1** SIGN PANEL: Digitally printed full-bleed color graphics on 3M Reflective DG3 4090 White film applied to 1st surface of alum. panel; mechanically fasten panel to existing dynamic display; attachment method to be approved by structural engineer; custom cut-out to expose existing dynamic unit; field verify all dimensions.
- F2** DIGITAL DISPLAY: Existing unit by others.
- F3** COLUMN: Paint existing column(s) with reflective paint to match Yellow PMS 116C

TYPEFACES

- L1** Typeface: Clearview Highway 3-W)

COLORS:

- C1** Yellow: PMS 116C
- C2** Black: PMS Black C

WARNING:

This record contains Sensitive Security Information that is controlled under 49 CFR parts 15 and 1520. No part of this record may be disclosed to persons with a "need to know," as defined in 49 CFR parts 15 and 1520, except with the written permission of the Administrator of the Transportation Security Administration or the Secretary of Transportation. Unauthorized release may result in civil penalty or other action. For U.S. government agencies, public disclosure is governed by 5 U.S.C. 552 and 49 CFR parts 15 and 1520.

ILLUMINATION	SIGN TYPE	SIGN FUNCTION	MOUNTING METHOD	GENERAL DESCRIPTION & USE
SOLAR/NON-ILLUMINATED	Roadside - Low Clearance	IDENTIFICATION	POLE MOUNT	VEHICULAR - Low Clearance Sign with LED Solar Warning Lights

GENERAL NOTES

- All final design, engineering, and amount/sizing of structural sign support elements, material types/thicknesses, dimensions, and attachment methods shall be performed and approved by a licensed engineer to meet or exceed all applicable local and national codes.
- Final engineering, dimensions, materials, and fabrication are the responsibility of the Fabricator to ensure the highest quality fit and finish for all components of the completed product. All final detailing and specifications to be provided by the Fabricator within their final approved fabrication-ready shop drawings.
- Wherever dissimilar metals are in contact, always separate contact surfaces prior to assembly or installation with the necessary protective coatings/gaskets/washers to prevent galvanic corrosion.
- Final fabrication methods, quality and fit/finish to be reviewed and approved by DFW Planning Department and wayfinding/architecture Design Consultants thru prototype reviews prior to final production run/installation processes (see Performance Specifications for details).
- Colors shown are for reference only, and are subject to the limitations of the printing process and/or variance of electronic RGB screen displays. Refer to color system swatches and/or final finish samples for accurate reference.
- Messages shown here are general placeholders only. See graphic message schedules for specific messaging by location and sign type.

FABRICATION INTENT NOTES

- F1** SIGN CABINET/FRAME: modular fabricated internal illuminated edge-lit sign module cabinet constructed of extruded aluminum and cast aluminum components with concealed internal welds; removable sign face and light modules; fabricated aluminum support frame with welded mitered corners and slotted mounting holes to accept sign mounting brackets; fabricated aluminum sign mounting frame with tapered side end cover panels, attached with aluminum pin and clip system; power feed/units hidden behind mounting frame with access holes in back for wall mounting; powdercoat all exposed surfaces of sign cabinet/support frame/mounting frame to match P1, satin finish
- F2** SIGN FACE: fabricated sign face assembly module constructed of extruded aluminum frame and concealed internal welds; faces are 3/16" white acrylic with 1st surface applied V1 vinyl film, graphics reversed out of blue (white is exposed white acrylic cut-thru blue film); faces illuminated with light panel assembly using LED edge-lit clear inscribed acrylic diffuser and self-contained technology (including electronics, extruded frame and diffuser)
- F3** TRIM: .080 fabricated aluminum trim piece with closed ends; detachable and mounted with keyholes/studs and set screws; paint all exposed surfaces to match P2, satin finish
- F4** MOUNTING: mount to wall structural elements with connection system as installation location conditions require (Fabricator to coordinate connection location/type of structural elements with General Contractor); paint all exposed surfaces to match P1, satin finish.
- F5** SOLAR TRAFFIC LIGHT 8" DIAMETER: by others.

GRAPHICS / COLORS / DECORATION NOTES

- L1** Typeface: font = ClearviewText Medium
- L2** Typeface: font = ClearviewText Bold
- S1** Universal Symbols: AIGA/TXDOT style symbol artwork
- S3** Veh. Arrow(s): use only official MUTCD/TXDOT arrow art

VINYL (FILM) / DIGITAL PRINT:

- V4** Light Green: match PMS 368C
- V7** White: 3M 4090 DG3 White (Reflective)
- V9** Blue: 3M 4095 DG3 Blue (Reflective)
- V8** Yellow: 3M 4091 DG3 (Reflective)
- V3** Yellow: 3M 3630-25
- V5** Black: 3M 7725-22

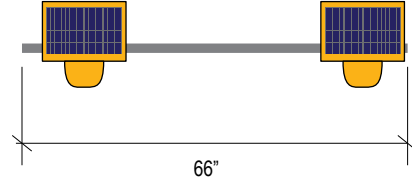
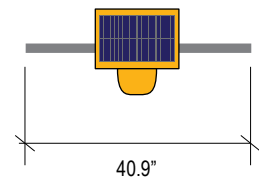

1 PLAN VIEW
Scale: NTS

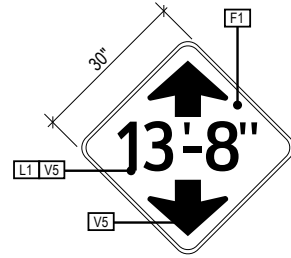

A FACE LAYOUT
Scale: NTS

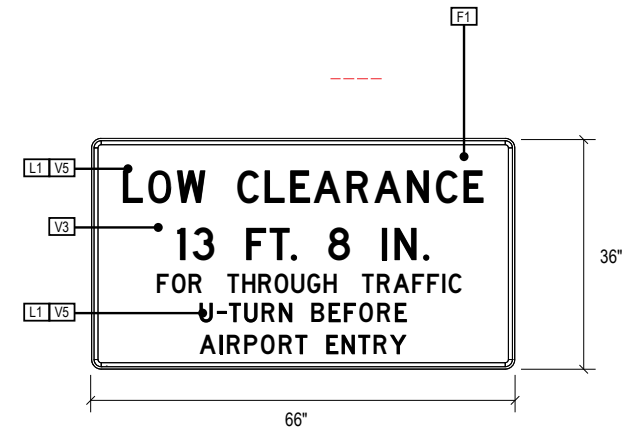
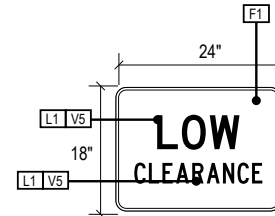

B FACE LAYOUT
Scale: NTS

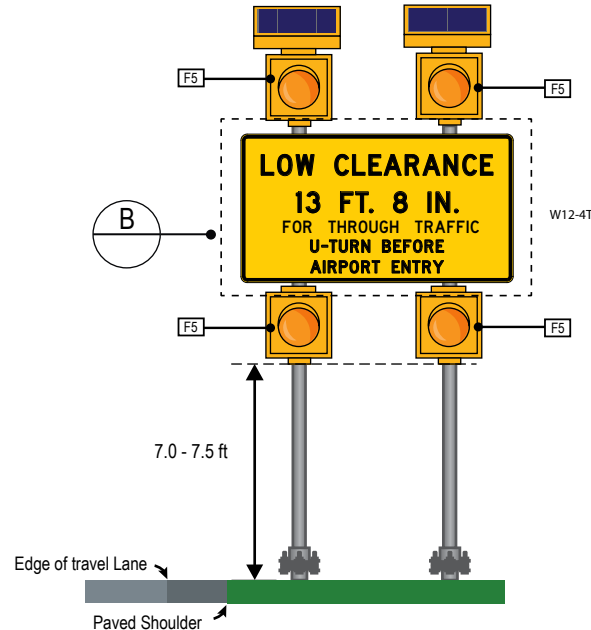
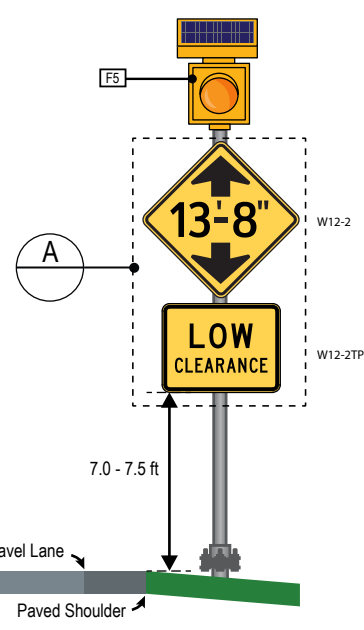

2 ELEVATION
Scale: NTS

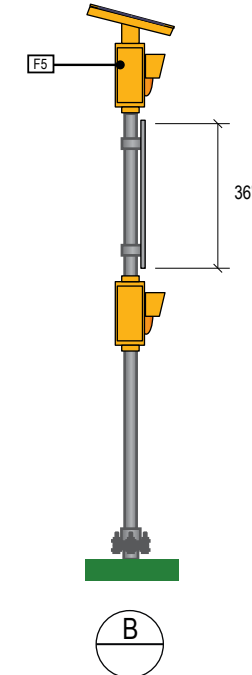
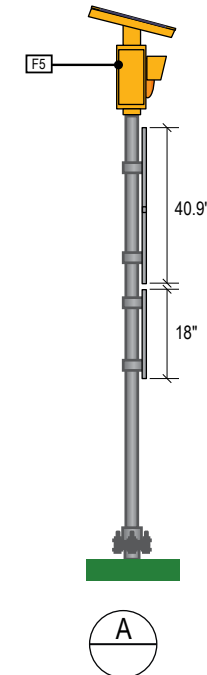

3 END VIEW
Scale: NTS

Sign to be placed at 12ft Minimum from edge of travel lane, or if paved shoulder is greater than 6 ft than minimum of 6 ft from paved shoulder edge

6.0

6.0 SIGN TYPES - GARAGE/PARKING AREAS

- 6.1 Sign Type Index
- 6.2 Sign Types

SIGN TYPE INDEX

GARAGES/PARKING AREAS

This chapter provides specific information regarding the wayfinding sign types applicable for use in the Garage/Parking areas of DFW Airport. It contains a general sign family overview of the specific sign types (i.e., the Sign Type Index section), as well as more specific design/layouts/notes/etc for each individual sign type (i.e., the Sign Types section).

On the following pages, the Sign Type Index shows simple views of each sign type, as well as listings for each sign type's name, mounting method and basic overall size. The Sign Type Index is intended only as a brief, simple catalog for all of the wayfinding sign types used within the Garage/Parking areas of DFW, and is organized in numeric order of their sign type identification numbers (i.e., Directional sign type category: 5-DR.01, 5-DR.02, etc; Identification sign type category: 5-ID.01, 5-ID.02, etc; Informational sign type category: 5-IN.01, 5-IN.02, etc).

Sign Types - Design Intent Drawings

Section 6.2 - Sign Types contains design intent drawings of each specific wayfinding sign type used within the Garage/Parking areas of DFW. Each sheet displays scaled drawings of individual sign types and their basic views (i.e., elevations, plan views, end view, etc), sizing/dimensions, face layouts and general design intent related notes.

NOTE: these documents are intended to illustrate design intent, and should only be used as a general guideline. No information contained here should be construed as engineered elements. The designer/fabricator/contractor shall be responsible for all engineering and specifications with regard to structural, electrical, mechanical, foundation and installation. Details and information contained in this document shall not be reproduced, copied or utilized in any way except for the specific project for which they were created without previous written authorization from DFW.

Mounting Requirements

Sign mountings shall support signs for optimum visibility, facilitate illumination where required, be fabricated from commonly available materials, be easily maintained, be engineered to established DFW wayfinding system and engineering requirements, and not obstruct or pose any hazard to pedestrians, vehicles or any other entity.

Basic Mounting Types

The basic mounting types used within DFW Garage/Parking areas are as follows:

- Ceiling Mount:
 - Suspended: Overhead signs located in high ceiling areas mounted with a suspension system mechanically attached to the sign's top most element and at the top of the suspension system, with the overall suspension system/sign attached to an above-ceiling structural support system
 - Flush Top: Overhead signs mounted in lower ceiling areas with the sign's top most element flush to the ceiling using a mechanical fastening system attached to an above-ceiling structural support system
- Wall/Soffit Mount: Signs that are located on a vertical architectural fascia (overhead) or wall (overhead or pedestrian eye-level), and mechanically attached to the fascia/wall's internal vertical structure
- Wall Mount - ADA/tactile plaques: Signs with tactile features that are mounted to walls, doors or other required elements to meet local/ADA accessibility requirements and codes for accessible design and use
- Light Pole/Column Wrap - Signs that are mounted to existing light poles or columns with mechanical fastening systems and/or surface applied film
- Flag (Blade) Mount: Overhead signs mechanically attached on one vertical edge to internal structural elements of vertical architectural surfaces (i.e. walls, columns, etc) in a "flagged" configuration
- Floor/Ground Mount: Non-moveable signs mechanically attached directly to structural elements of an architectural floor or in-ground structural mounting methods
- Freestanding (Moveable): Signs that utilize freestanding, non-attached base configurations, typically with wide and weighted footer features (to eliminate accidental tipping over); allow for flexibility in moving a sign as changing location conditions require

General Mounting Restrictions - Pedestrian Signs

- Overhead signs will always be mounted at a minimum of 7'-0" above finished floor to the bottom of the lowest element of the sign, unless otherwise indicated or dictated by minimum garage clearance (varies per garage, field verify prior to final fabrication and installation)
- ADA accessibility and code required signage (when used) shall be mounted in accordance with all applicable code requirements using the most recent edition of the codes and regulations
- Whenever there is a conflict between a requirement listed in this document and another authoritative code or standard, the more stringent one shall be applied

General Mounting Restrictions - Vehicular Signs

- Vehicular wayfinding signs shall always be mounted perpendicular to vehicular traffic flow
- Overhead and roadside signs: all mounting, lateral positioning/spacing from edge of roadway and clearances must be reviewed and approved by a traffic engineer licensed in the State of Texas prior to fabrication and installation
- Ground-mounted vehicular signs (if used) must be mounted behind crash barriers, use break-away base mounting systems and/or utilize hinged-top connectors (overhead suspended only) in the event of an accidental vehicular collision and as required by TXDOT
- Vehicular roadside signs must be mounted with the bottom-most viewable area of the sign at a minimum of 7'-0" above finished grade unless otherwise indicated
- Vehicular signs located in the garage will allow for a minimum of overhead garage clearance (varies per garage, field verify prior to final fabrication and installation)
- Whenever there is a conflict between a requirement listed in this document and another authoritative code or standard, the more stringent one shall be applied

WARNING:

This record contains Sensitive Security Information that is controlled under 49 CFR parts 15 and 1520. No part of this record may be disclosed to persons with a "need to know," as defined in 49 CFR parts 15 and 1520, except with the written permission of the Administrator of the Transportation Security Administration or the Secretary of Transportation. Unauthorized release may result in civil penalty or other action. For U.S. government agencies, public disclosure is governed by 5 U.S.C. 552 and 49 CFR parts 15 and 1520.

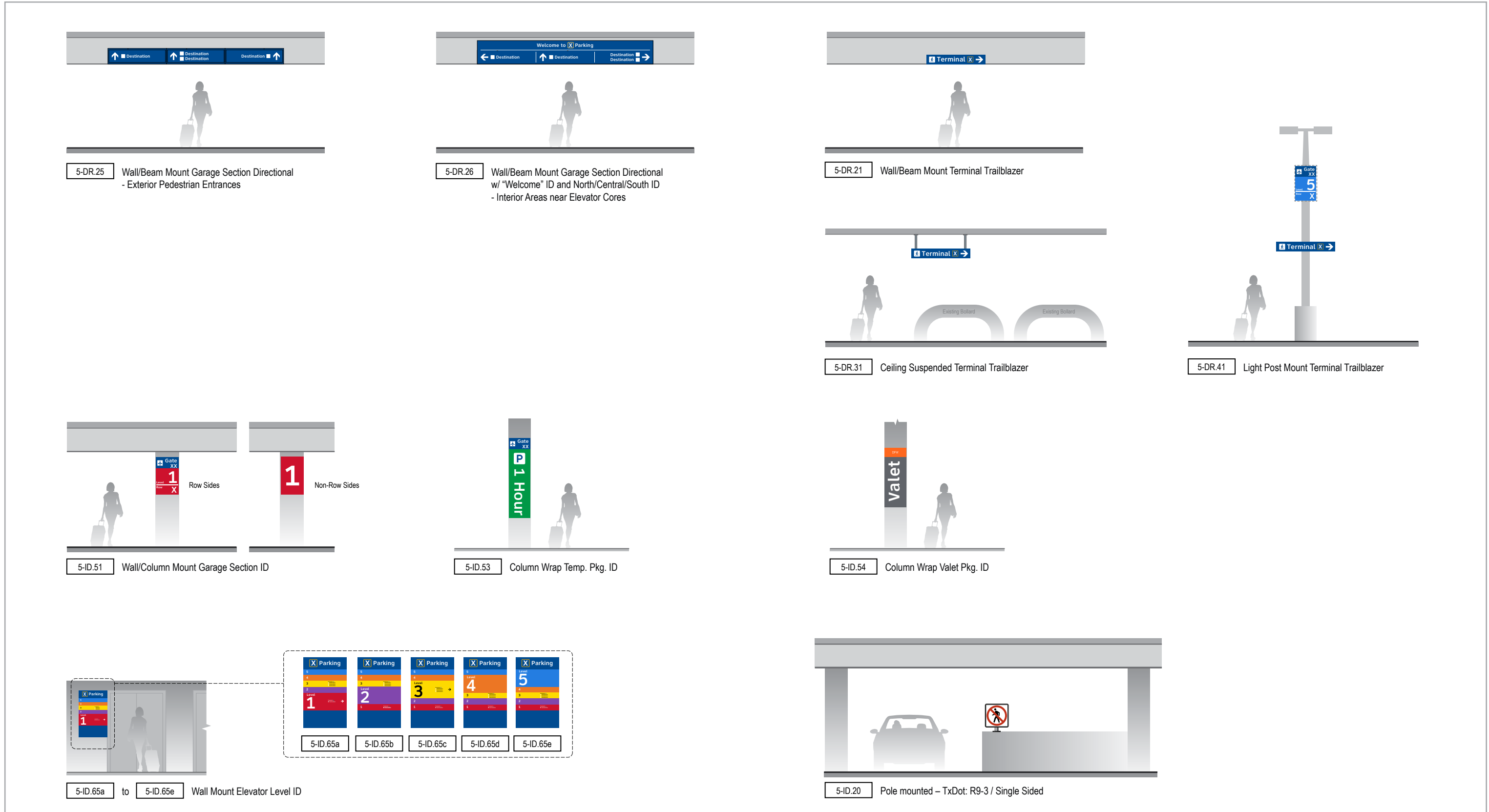
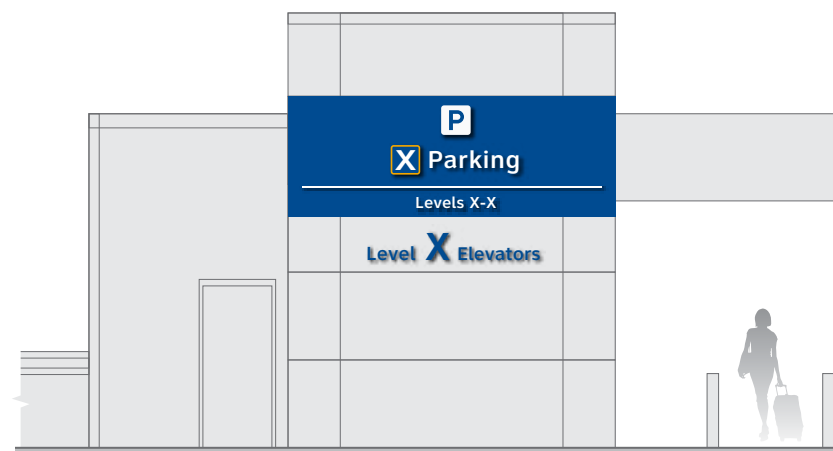

Figure 1.1.8d DFW Wayfinding Sign Family: **Garage/Parking Areas - Pedestrian**



5-ID.55 Wall Mount Large Pedestrian Garage Entrance ID



5-ID.56 Wall Mount Elevator Garage/Level ID

Figure 1.1.8d (cont.)

DFW Wayfinding Sign Family: **Garage/Parking Areas - Pedestrian (cont.)**

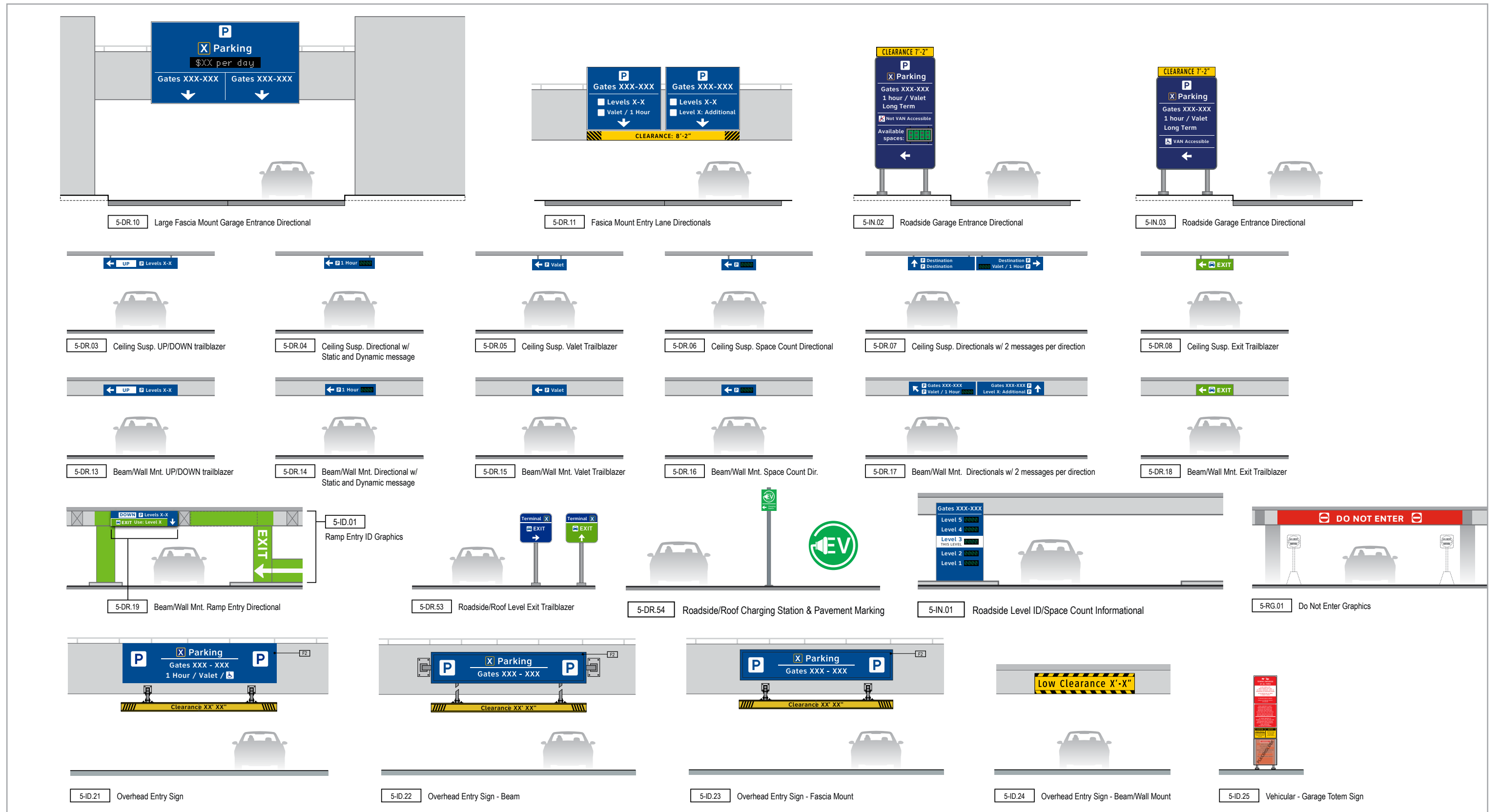

Figure 1.1.8d (cont.) DFW Wayfinding Sign Family: **Garage/Parking Areas - Pedestrian (cont.)**

ILLUMINATION	SIGN TYPE	SIGN FUNCTION	MOUNTING METHOD	GENERAL DESCRIPTION & USE
REFLECTIVE	5-DR.03	DIRECTIONAL	CEILING SUSPENDED	VEHICULAR - UP/DOWN Trailblazer; 1 direction; 1 or 2 sides

GENERAL NOTES

- All final design, engineering, and amount/sizing of structural sign support elements, material types/thicknesses, dimensions, and attachment methods shall be performed and approved by a licensed engineer to meet or exceed all applicable local and national codes.
- Final engineering, dimensions, materials, and fabrication are the responsibility of the Fabricator to ensure the highest quality fit and finish for all components of the completed product. All final detailing and specifications to be provided by the Fabricator within their final approved fabrication-ready shop drawings.
- Wherever dissimilar metals are in contact, always separate contact surfaces prior to assembly or installation with the necessary protective coatings/gaskets/washers to prevent galvanic corrosion.
- Final fabrication methods, quality and fit/finish to be reviewed and approved by DFW Airport Planning Department and wayfinding/architecture Design Consultants thru prototype reviews prior to final production run/installation processes (see Performance Specifications for details).
- Colors shown are for reference only, and are subject to the limitations of the printing process and/or variance of electronic RGB screen displays. Refer to color system swatches and/or final finish samples for accurate reference.
- Messages shown here are general placeholders only. See graphic message schedules for specific messaging by location and sign type.

FABRICATION INTENT NOTES

- F1** SIGN CABINET/FRAME: modular fabricated internal illuminated edge-lit sign module cabinet constructed of extruded aluminum and cast aluminum components with concealed internal welds; removable sign face and light modules; fabricated aluminum support frame with welded mitered corners and slotted mounting holes to accept sign mounting brackets; fabricated alum. sign mounting frame with tapered side end cover panels, attached with aluminum pin and clip system; power feed/units hidden behind mounting frame with access holes in back for wall mounting; powdercoat all exposed surfaces of sign cabinet/support frame/mounting frame to match P1 satin finish
- F2** SIGN FACE: fabricated sign face assembly module constructed of extruded aluminum frame and concealed internal welds; faces are 3/16" white acrylic with 1st surface applied V1 vinyl film, graphics reversed out of blue (white is exposed white acrylic cut-thru blue film); faces illuminated with light panel assembly using LED edge-lit clear inscribed acrylic diffuser and self-contained technology (including electronics, extruded frame and diffuser)
- F3** TRIM: .080 fabricated alum. trim piece with closed ends; detachable and mounted with keyholes/studs and set screws; paint all exposed surfaces to match P2, satin finish
- F4** MOUNTING: mount to hidden above-ceiling structural elements with connection system as installation location conditions require (Fabricator to coordinate connection location/type of structural elements with General Contractor); 2" diameter aluminum suspension tube supports with 4" diameter 3/16" aluminum escutcheon cover plate at ceiling connection point, paint all exposed surfaces to match P2, satin finish; attached to sign support frame with weld applied flanges and mechanical fasteners

GRAPHICS / COLORS / DECORATION NOTES

- L1** Typeface: font = ClearviewText Medium
 - L2** Typeface: font = ClearviewText Bold
 - S1** Universal Symbols: AIGA/TXDOT style symbol artwork
 - S3** Veh. Arrow(s): use only official MUTCD/TXDOT arrow art
- VINYL (FILM) / DIGITAL PRINT:
- V7** White: 3M 4090 DG3 White (Reflective)
 - V9** Blue: 3M 4095 DG3 Blue (Reflective)
- PAINT:
- P2** Silver: Matthews Paint #MP30136 Brushed Aluminum, satin finish

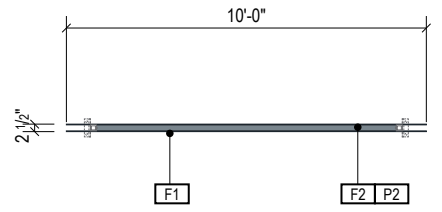

1 PLAN VIEW
Scale: 3/16" = 1'-0"

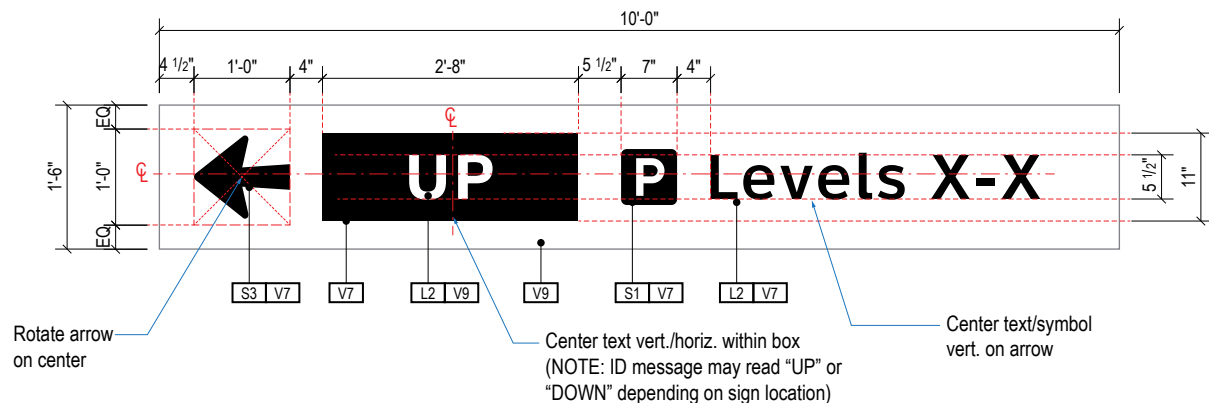

A FACE LAYOUT
Scale: 1/2" = 1'-0"

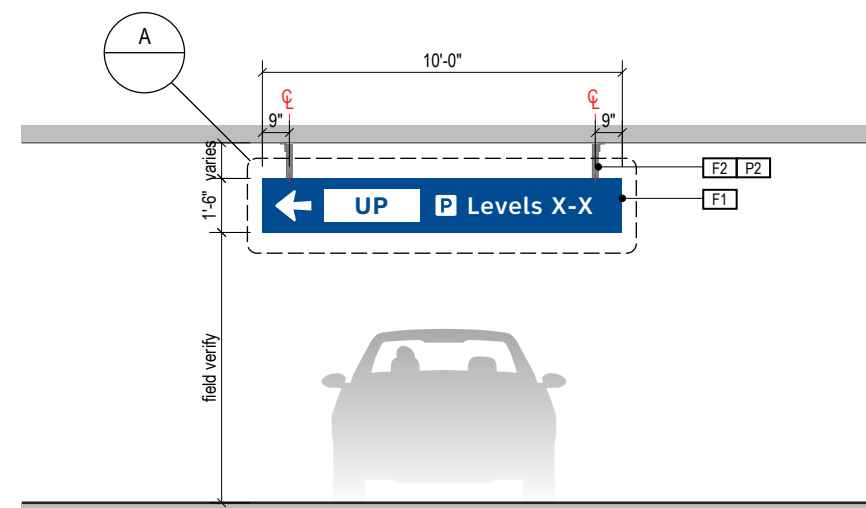

2 ELEVATION
Scale: 3/16" = 1'-0"

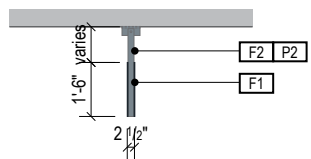

3 END VIEW
Scale: 3/16" = 1'-0"

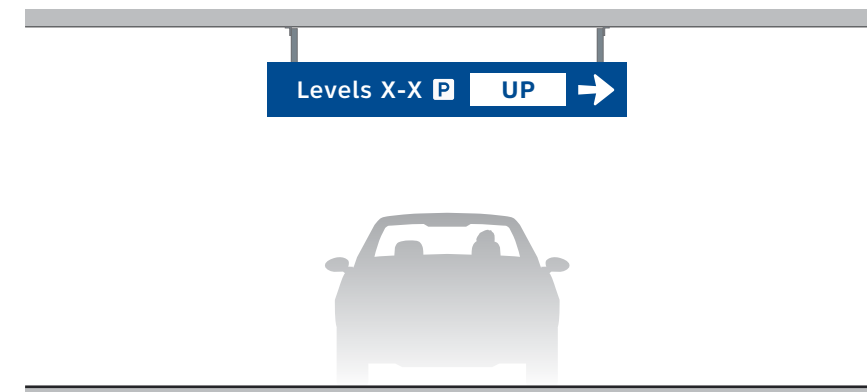

4 ELEVATION (OPPOSITE SIDE)
Scale: 3/16" = 1'-0"

ILLUMINATION	SIGN TYPE	SIGN FUNCTION	MOUNTING METHOD	GENERAL DESCRIPTION & USE
REFLECTIVE / DYNAMIC LED	5-DR.04	DIRECTIONAL	CEILING SUSPENDED	VEHICULAR - Directional w/ Static & Dynamic message; 1 direction; 1 or 2 sides

GENERAL NOTES

- All final design, engineering, and amount/sizing of structural sign support elements, material types/thicknesses, dimensions, and attachment methods shall be performed and approved by a licensed engineer to meet or exceed all applicable local and national codes.
- Final engineering, dimensions, materials, and fabrication are the responsibility of the Fabricator to ensure the highest quality fit and finish for all components of the completed product. All final detailing and specifications to be provided by the Fabricator within their final approved fabrication-ready shop drawings.
- Wherever dissimilar metals are in contact, always separate contact surfaces prior to assembly or installation with the necessary protective coatings/gaskets/washers to prevent galvanic corrosion.
- Final fabrication methods, quality and fit/finish to be reviewed and approved by DFW Planning Department and wayfinding/architecture Design Consultants thru prototype reviews prior to final production run/installation processes (see Performance Specifications for details).
- Colors shown are for reference only, and are subject to the limitations of the printing process and/or variance of electronic RGB screen displays. Refer to color system swatches and/or final finish samples for accurate reference.
- Messages shown here are general placeholders only. See graphic message schedules for specific messaging by location and sign type.

FABRICATION INTENT NOTES

- F1** SIGN BOX: fabricated aluminum extrusion frame with removable aluminum face panels, all welds filled and ground smooth for seamless appearance; removable faces use internal hidden top aluminum panel clip and are mechanically fastened with countersunk S.S. screws at bottom returns edges of extrusion frame (paint screwheads to match returns) into internal aluminum angle; vertical support tubes mechanically fastened to top of sign box extrusion frame; digitally printed full-bleed color graphics on 3M Reflective DG3 4090 White film applied to 1st surface of face panels; all exposed surfaces, returns, etc to be painted with MAP paint to match P1, satin finish; routed cut-outs in face panels and vents in sign box sized per dynamic unit required
- F2** SUPPORT FRAME/SUSPENSION: fabricated 2" square aluminum support tube frame and vertical suspension tube structure; all exposed support frame tube ends to be capped with aluminum; all welds on frame/caps to be filled and ground smooth for uniform appearance; suspension tubes mechanically attached to ceiling attachment hinge plates above; ceiling attachment plates to be mechanically fastened to garage's structural ceiling elements as required with mech. fasteners (fabricator to field verify); support frame, suspension tubes and hinge plates to be painted all exposed surfaces with MAP paint to match P2, satin finish
- F3** DYNAMIC SPACE COUNT UNIT: By others

GRAPHICS / COLORS / DECORATION NOTES

- L1** Typeface: font = ClearviewText Medium
 - S1** Universal Symbols: AIGA/TXDOT style symbol artwork
 - S3** Veh. Arrow(s): use only official MUTCD/TXDOT arrow art
- VINYL (FILM) / DIGITAL PRINT:
- V7** White: 3M 4090 DG3 White (Reflective)
 - V9** Blue: 3M 4095 DG3 Blue (Reflective)
- PAINT:
- P2** Silver: Matthews Paint #MP30136 Brushed Aluminum, satin finish

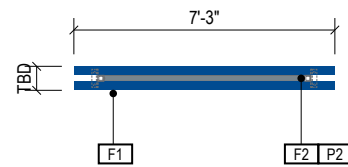

1 PLAN VIEW
Scale: 3/16" = 1'-0"

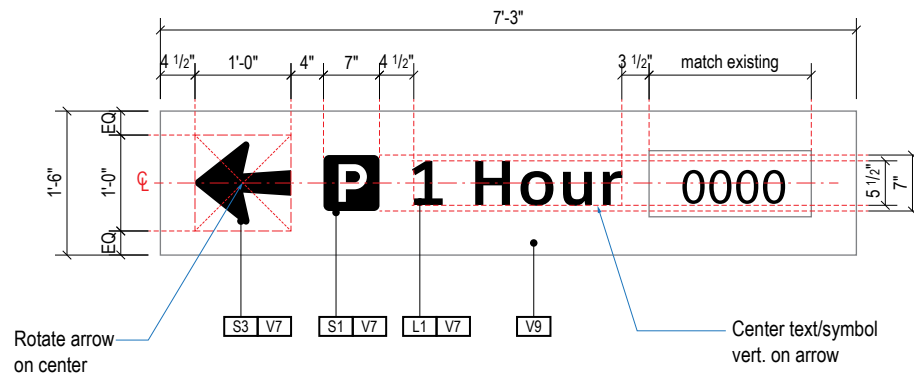

A FACE LAYOUT
Scale: 1/2" = 1'-0"

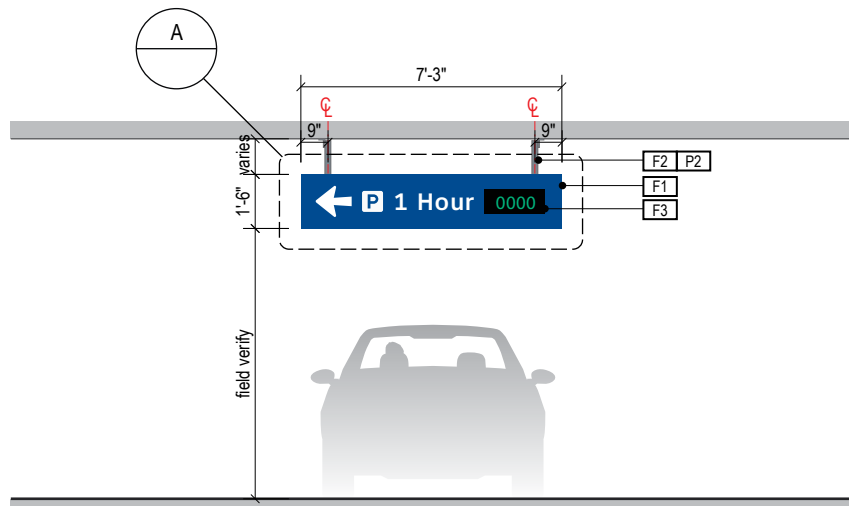

2 ELEVATION
Scale: 3/16" = 1'-0"

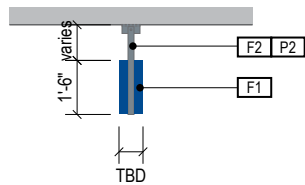

3 END VIEW
Scale: 3/16" = 1'-0"

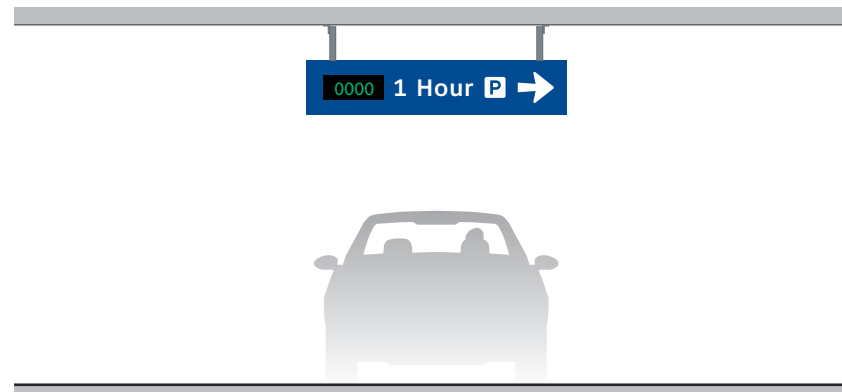

4 ELEVATION (OPPOSITE SIDE)
Scale: 3/16" = 1'-0"

ILLUMINATION	SIGN TYPE	SIGN FUNCTION	MOUNTING METHOD	GENERAL DESCRIPTION & USE
REFLECTIVE	5-DR.05	DIRECTIONAL	CEILING SUSPENDED	VEHICULAR - Valet Trailblazer; 1 direction; 1 or 2 sides

GENERAL NOTES

- All final design, engineering, and amount/sizing of structural sign support elements, material types/thicknesses, dimensions, and attachment methods shall be performed and approved by a licensed engineer to meet or exceed all applicable local and national codes.
- Final engineering, dimensions, materials, and fabrication are the responsibility of the Fabricator to ensure the highest quality fit and finish for all components of the completed product. All final detailing and specifications to be provided by the Fabricator within their final approved fabrication-ready shop drawings.
- Wherever dissimilar metals are in contact, always separate contact surfaces prior to assembly or installation with the necessary protective coatings/gaskets/washers to prevent galvanic corrosion.
- Final fabrication methods, quality and fit/finish to be reviewed and approved by DFW Planning Department and wayfinding/architecture Design Consultants thru prototype reviews prior to final production run/installation processes (see Performance Specifications for details).
- Colors shown are for reference only, and are subject to the limitations of the printing process and/or variance of electronic RGB screen displays. Refer to color system swatches and/or final finish samples for accurate reference.
- Messages shown here are general placeholders only. See graphic message schedules for specific messaging by location and sign type.

FABRICATION INTENT NOTES

- F1** SIGN FACE PANELS: 1/8" thick aluminum sign face panels; mechanically fasten sign panels to support tube structure with stainless steel countersunk screws, paint heads to match sign face; digitally printed full-bleed color graphics on 3M Reflective DG3 4090 White film applied to 1st surface of face panels; all exposed surfaces, returns, etc. to be clearcoated to prevent corrosion
- F2** SUPPORT FRAME/SUSPENSION: fabricated 2" square aluminum support tube frame and vertical suspension tube structure; all exposed support frame tube ends to be capped with aluminum; all welds on frame/caps to be filled and ground smooth for uniform appearance; suspension tubes mechanically attached to ceiling attachment hinge plates above; ceiling attachment plates to be mechanically fastened to garage's structural ceiling elements as required with mech. fasteners (fabricator to field verify); support frame, suspension tubes and hinge plates to be painted all exposed surfaces with MAP paint to match P2, satin finish

GRAPHICS / COLORS / DECORATION NOTES

- L1** Typeface: font = ClearviewText Medium
 - S1** Universal Symbols: AIGATXDOT style symbol artwork
 - S3** Veh. Arrow(s): use only official MUTCD/TXDOT arrow art
- VINYL (FILM) / DIGITAL PRINT:
- V7** White: 3M 4090 DG3 White (Reflective)
 - V9** Blue: 3M 4095 DG3 Blue (Reflective)
- PAINT:
- P2** Silver: Matthews Paint #MP30136 Brushed Aluminum, satin finish

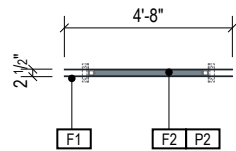

1 PLAN VIEW
Scale: 3/16" = 1'-0"

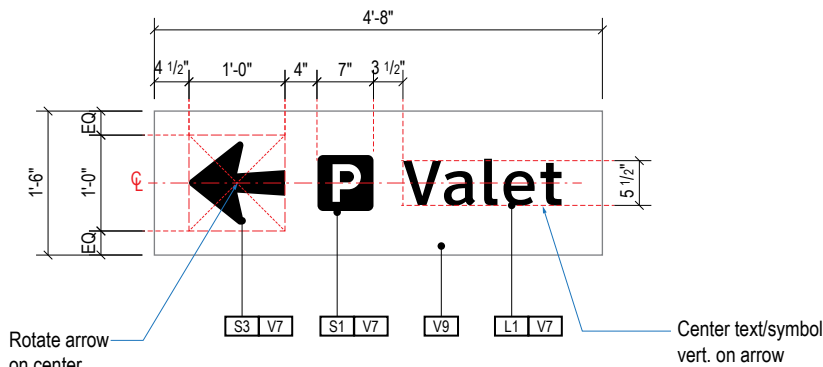

A FACE LAYOUT
Scale: 1/2" = 1'-0"

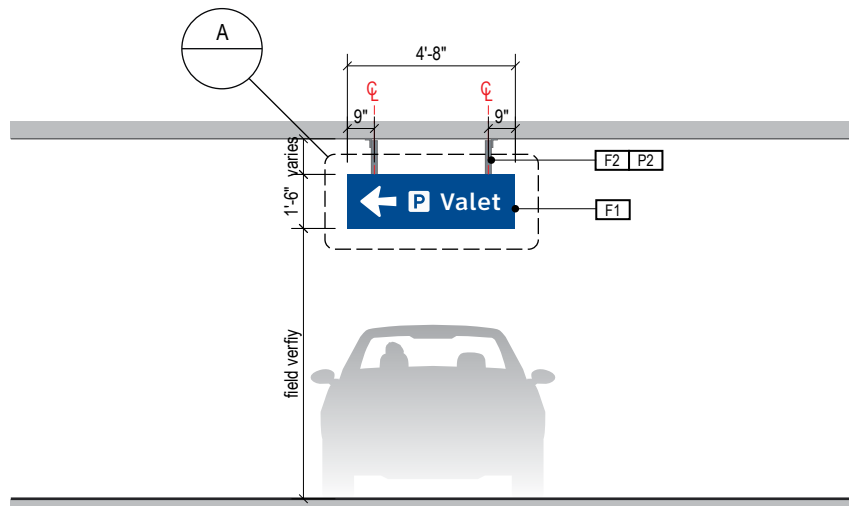

2 ELEVATION
Scale: 3/16" = 1'-0"

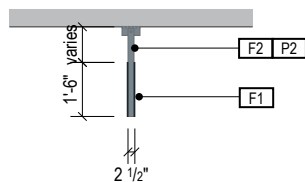

3 END VIEW
Scale: 3/16" = 1'-0"

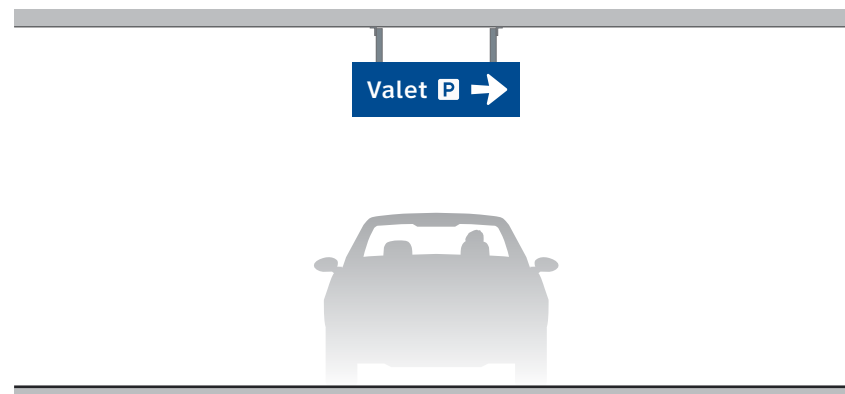

4 ELEVATION (OPPOSITE SIDE)
Scale: 3/16" = 1'-0"

ILLUMINATION	SIGN TYPE	SIGN FUNCTION	MOUNTING METHOD	GENERAL DESCRIPTION & USE
REFLECTIVE / DYNAMIC LED	5-DR.06	DIRECTIONAL	CEILING SUSPENDED	VEHICULAR - Space Count Directional; 1 direction; 1 or 2 sides

GENERAL NOTES

- All final design, engineering, and amount/sizing of structural sign support elements, material types/thicknesses, dimensions, and attachment methods shall be performed and approved by a licensed engineer to meet or exceed all applicable local and national codes.
- Final engineering, dimensions, materials, and fabrication are the responsibility of the Fabricator to ensure the highest quality fit and finish for all components of the completed product. All final detailing and specifications to be provided by the Fabricator within their final approved fabrication-ready shop drawings.
- Wherever dissimilar metals are in contact, always separate contact surfaces prior to assembly or installation with the necessary protective coatings/gaskets/washers to prevent galvanic corrosion.
- Final fabrication methods, quality and fit/finish to be reviewed and approved by DFW Planning Department and wayfinding/architecture Design Consultants thru prototype reviews prior to final production run/installation processes (see Performance Specifications for details).
- Colors shown are for reference only, and are subject to the limitations of the printing process and/or variance of electronic RGB screen displays. Refer to color system swatches and/or final finish samples for accurate reference.
- Messages shown here are general placeholders only. See graphic message schedules for specific messaging by location and sign type.

FABRICATION INTENT NOTES

- F1** SIGN BOX: fabricated aluminum extrusion frame with removable aluminum face panels, all welds filled and ground smooth for seamless appearance; removable faces use internal hidden top aluminum panel clip and are mechanically fastened with countersunk S.S. screws at bottom returns edges of extrusion frame (paint screwheads to match returns) into internal aluminum angle; vertical support tubes mechanically fastened to top of sign box extrusion frame; digitally printed full-bleed color graphics on 3M Reflective DG3 4090 White film applied to 1st surface of face panels; all exposed surfaces, returns, etc to be painted with MAP paint to match P1, satin finish; routed cut-outs in face panels and vents in sign box sized per dynamic unit required
- F2** SUPPORT FRAME/SUSPENSION: fabricated 2" square aluminum support tube frame and vertical suspension tube structure; all exposed support frame tube ends to be capped with aluminum; all welds on frame/caps to be filled and ground smooth for uniform appearance; suspension tubes mechanically attached to ceiling attachment hinge plates above; ceiling attachment plates to be mechanically fastened to garage's structural ceiling elements as required with mech. fasteners (fabricator to field verify); support frame, suspension tubes and hinge plates to be painted all exposed surfaces with MAP paint to match P2, satin finish
- F3** DYNAMIC SPACE COUNT UNIT: By others

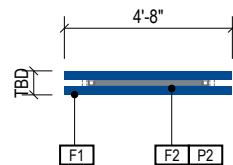

1 PLAN VIEW

Scale: 3/16" = 1'-0"

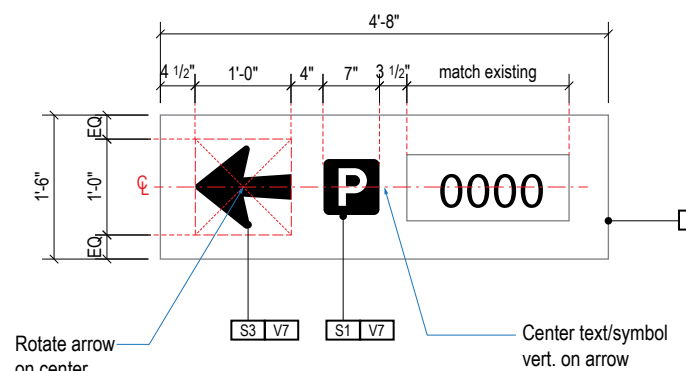

A FACE LAYOUT

Scale: 1/2" = 1'-0"

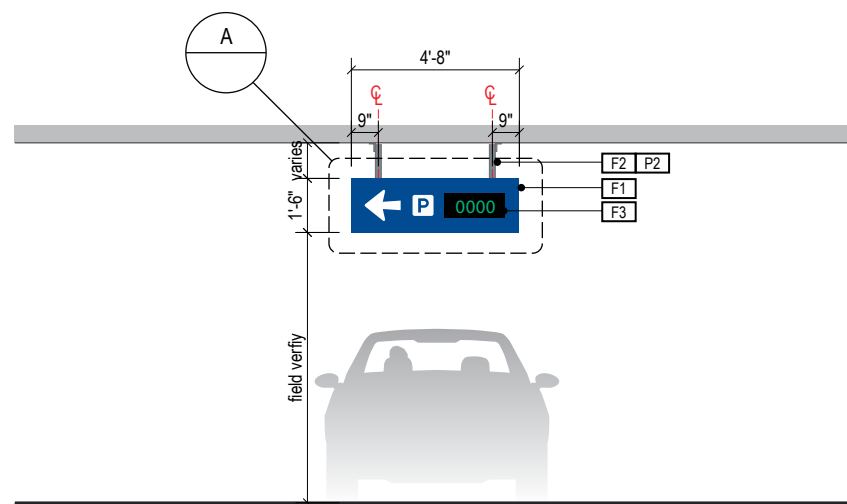

2 ELEVATION

Scale: 3/16" = 1'-0"

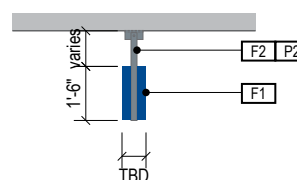

3 END VIEW

Scale: 3/16" = 1'-0"

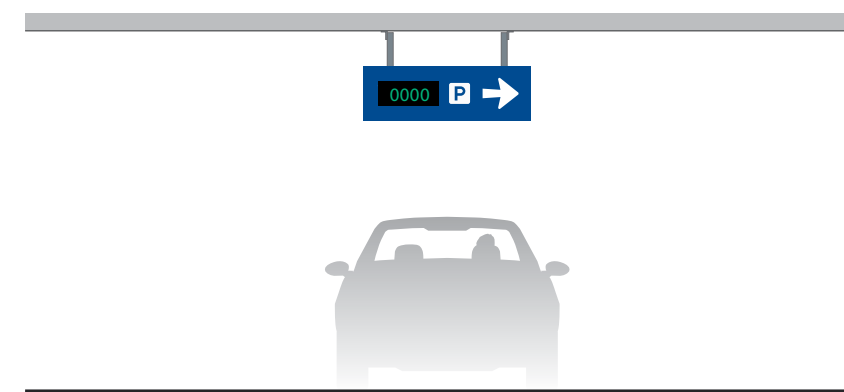

4 ELEVATION (OPPOSITE SIDE)

Scale: 3/16" = 1'-0"

GRAPHICS / COLORS / DECORATION NOTES

- L1** Typeface: font = ClearviewText Medium
- S1** Universal Symbols: AIGA/TXDOT style symbol artwork
- S3** Veh. Arrow(s): use only official MUTCD/TXDOT arrow art
- VINYL (FILM) / DIGITAL PRINT:
 - V7** White: 3M 4090 DG3 White (Reflective)
 - V9** Blue: 3M 4095 DG3 Blue (Reflective)
- PAINT:
 - P2** Silver: Matthews Paint #MP30136 Brushed Aluminum, satin finish

WARNING:

This record contains Sensitive Security Information that is controlled under 49 CFR parts 15 and 1520. No part of this record may be disclosed to persons with a "need to know," as defined in 49 CFR parts 15 and 1520, except with the written permission of the Administrator of the Transportation Security Administration or the Secretary of Transportation. Unauthorized release may result in civil penalty or other action. For U.S. government agencies, public disclosure is governed by 5 U.S.C. 552 and 49 CFR parts 15 and 1520.

ILLUMINATION	SIGN TYPE	SIGN FUNCTION	MOUNTING METHOD	GENERAL DESCRIPTION & USE
REFLECTIVE / DYNAMIC LED	5-DR.07	DIRECTIONAL	CEILING SUSPENDED	VEHICULAR - Directionals w/ 2 messages per direction; 2 directions; 1 or 2 sides

GENERAL NOTES

- All final design, engineering, and amount/sizing of structural sign support elements, material types/thicknesses, dimensions, and attachment methods shall be performed and approved by a licensed engineer to meet or exceed all applicable local and national codes.
- Final engineering, dimensions, materials, and fabrication are the responsibility of the Fabricator to ensure the highest quality fit and finish for all components of the completed product. All final detailing and specifications to be provided by the Fabricator within their final approved fabrication-ready shop drawings.
- Wherever dissimilar metals are in contact, always separate contact surfaces prior to assembly or installation with the necessary protective coatings/gaskets/washers to prevent galvanic corrosion.
- Final fabrication methods, quality and fit/finish to be reviewed and approved by DFW Planning Department and wayfinding/architecture Design Consultants thru prototype reviews prior to final production run/installation processes (see Performance Specifications for details).
- Colors shown are for reference only, and are subject to the limitations of the printing process and/or variance of electronic RGB screen displays. Refer to color system swatches and/or final finish samples for accurate reference.
- Messages shown here are general placeholders only. See graphic message schedules for specific messaging by location and sign type.

FABRICATION INTENT NOTES

- F1** SIGN BOX: fabricated aluminum extrusion frame with removable aluminum face panels, all welds filled and ground smooth for seamless appearance; removable faces use internal hidden top aluminum panel clip and are mechanically fastened with countersunk S.S. screws at bottom returns edges of extrusion frame (paint screwheads to match returns) into internal aluminum angle; vertical support tubes mechanically fastened to top of sign box extrusion frame; digitally printed full-bleed color graphics on 3M Reflective DG3 4090 White film applied to 1st surface of face panels; all exposed surfaces, returns, etc to be painted with MAP paint to match P1, satin finish; routed cut-outs in face panels and vents in sign box sized per dynamic unit required
- F2** SUPPORT FRAME/SUSPENSION: fabricated 2" square aluminum support tube frame and vertical suspension tube structure; all exposed support frame tube ends to be capped with aluminum; all welds on frame/caps to be filled and ground smooth for uniform appearance; suspension tubes mechanically attached to ceiling attachment hinge plates above; ceiling attachment plates to be mechanically fastened to garage's structural ceiling elements as required with mech. fasteners (fabricator to field verify); support frame, suspension tubes and hinge plates to be painted all exposed surfaces with MAP paint to match P2, satin finish
- F3** DYNAMIC SPACE COUNT UNIT: By others

GRAPHICS / COLORS / DECORATION NOTES

- L1** Typeface: font = ClearviewText Medium
 - S1** Universal Symbols: AIGA/TXDOT style symbol artwork
 - S3** Veh. Arrow(s): use only official MUTCD/TXDOT arrow art
- VINYL (FILM) / DIGITAL PRINT:
- V7** White: 3M 4090 DG3 White (Reflective)
 - V9** Blue: 3M 4095 DG3 Blue (Reflective)
- PAINT:
- P2** Silver: Matthews Paint #MP30136 Brushed Aluminum, satin finish

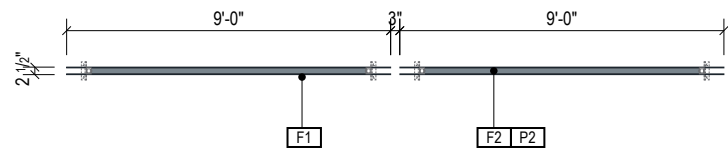

1 PLAN VIEW
Scale: 3/16" = 1'-0"

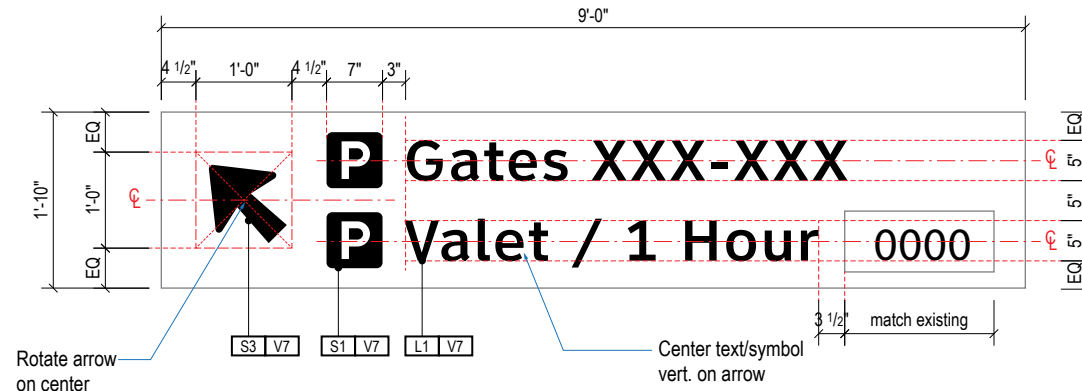

A FACE LAYOUT
Scale: 1/2" = 1'-0"

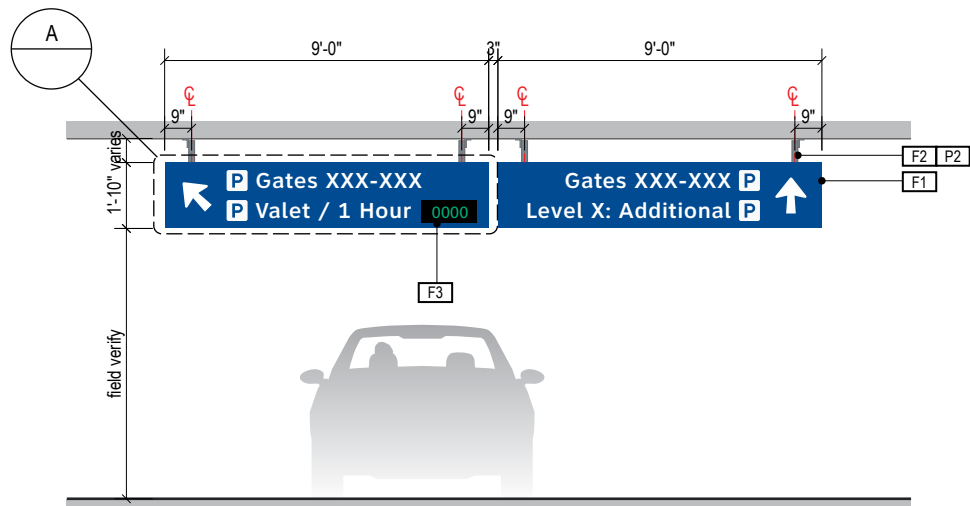

2 ELEVATION
Scale: 3/16" = 1'-0"

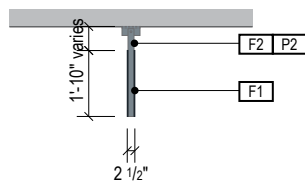

3 END VIEW
Scale: 3/16" = 1'-0"

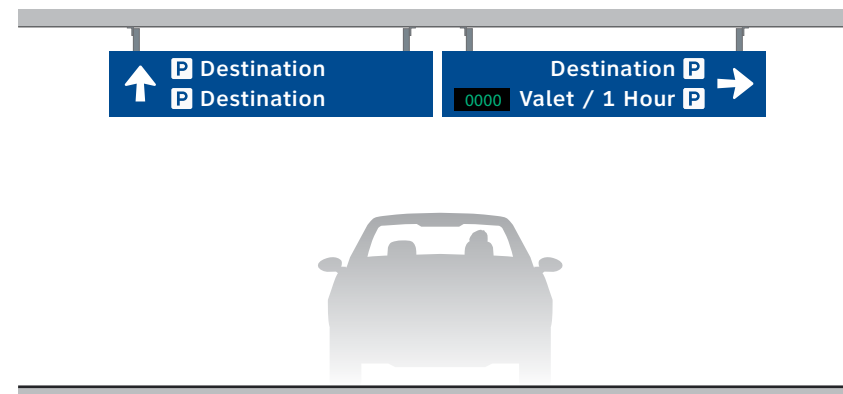

4 ELEVATION (OPPOSITE SIDE)
Scale: 3/16" = 1'-0"

ILLUMINATION	SIGN TYPE	SIGN FUNCTION	MOUNTING METHOD	GENERAL DESCRIPTION & USE
REFLECTIVE	5-DR.08	DIRECTIONAL	CEILING SUSPENDED	VEHICULAR - Exit Trailblazer, 1 direction; 1 or 2 sides

GENERAL NOTES

- All final design, engineering, and amount/sizing of structural sign support elements, material types/thicknesses, dimensions, and attachment methods shall be performed and approved by a licensed engineer to meet or exceed all applicable local and national codes.
- Final engineering, dimensions, materials, and fabrication are the responsibility of the Fabricator to ensure the highest quality fit and finish for all components of the completed product. All final detailing and specifications to be provided by the Fabricator within their final approved fabrication-ready shop drawings.
- Wherever dissimilar metals are in contact, always separate contact surfaces prior to assembly or installation with the necessary protective coatings/gaskets/washers to prevent galvanic corrosion.
- Final fabrication methods, quality and fit/finish to be reviewed and approved by DFW Planning Department and wayfinding/architecture Design Consultants thru prototype reviews prior to final production run/installation processes (see Performance Specifications for details).
- Colors shown are for reference only, and are subject to the limitations of the printing process and/or variance of electronic RGB screen displays. Refer to color system swatches and/or final finish samples for accurate reference.
- Messages shown here are general placeholders only. See graphic message schedules for specific messaging by location and sign type.

FABRICATION INTENT NOTES

- F1** SIGN FACE PANELS: 1/8" thick aluminum sign face panels; mechanically fasten sign panels to support tube structure with stainless steel countersunk screws, paint heads to match sign face; digitally printed full-bleed color graphics on 3M Reflective DG3 4090 White film applied to 1st surface of face panels; all exposed surfaces, returns, etc. to be clearcoated to prevent corrosion
- F2** SUPPORT FRAME/SUSPENSION: fabricated 2" square aluminum support tube frame and vertical suspension tube structure; all exposed support frame tube ends to be capped with aluminum; all welds on frame/caps to be filled and ground smooth for uniform appearance; suspension tubes mechanically attached to ceiling attachment hinge plates above; ceiling attachment plates to be mechanically fastened to garage's structural ceiling elements as required with mech. fasteners (fabricator to field verify); support frame, suspension tubes and hinge plates to be painted all exposed surfaces with MAP paint to match P2, satin finish

GRAPHICS / COLORS / DECORATION NOTES

- L2** Typeface: font = ClearviewText Bold
 - S1** Universal Symbols: AIGA/TXDOT style symbol artwork
 - S3** Veh. Arrow(s): use only official MUTCD/TXDOT arrow art
- VINYL (FILM) / DIGITAL PRINT:
- V4** Light Green: match PMS 368C
 - V7** White: 3M 4090 DG3 White (Reflective)
 - V9** Blue: 3M 4095 DG3 Blue (Reflective)
- PAINT:
- P2** Silver: Matthews Paint #MP30136 Brushed Aluminum, satin finish

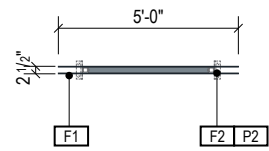

1 PLAN VIEW
Scale: 3/16" = 1'-0"

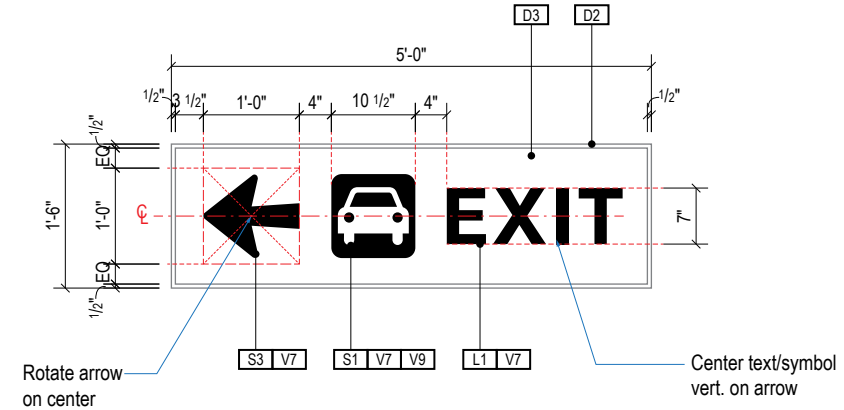

A FACE LAYOUT
Scale: 1/2" = 1'-0"

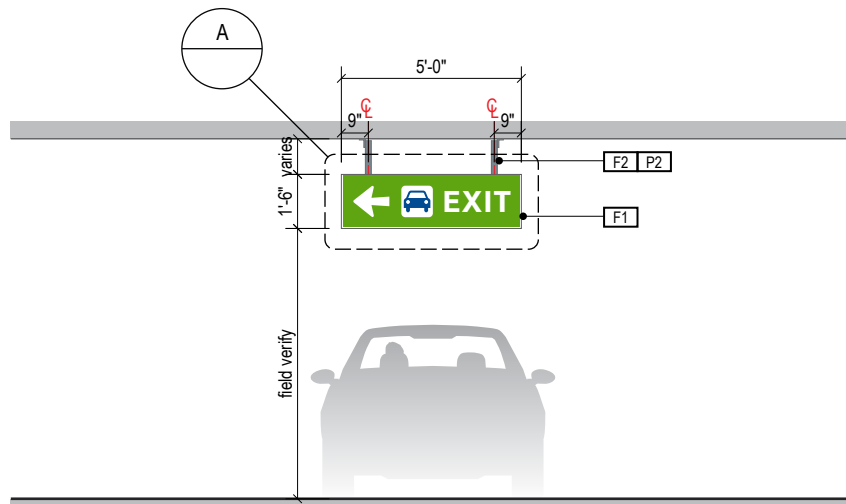

2 ELEVATION
Scale: 3/16" = 1'-0"

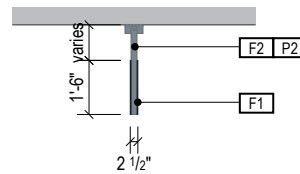

3 END VIEW
Scale: 3/16" = 1'-0"

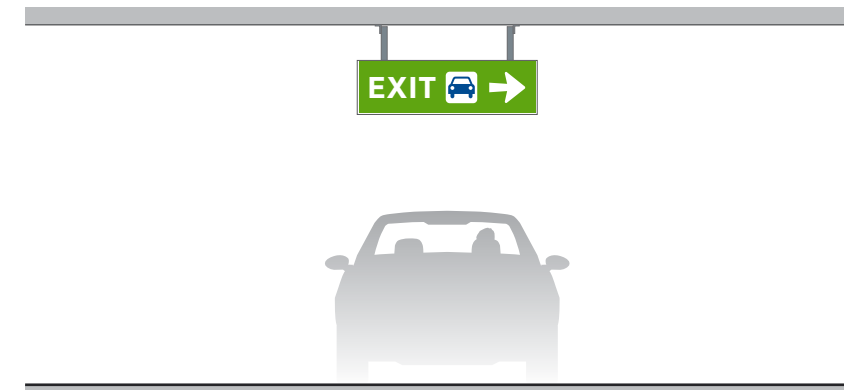

4 ELEVATION (OPPOSITE SIDE)
Scale: 3/16" = 1'-0"

WARNING:

This record contains Sensitive Security Information that is controlled under 49 CFR parts 15 and 1520. No part of this record may be disclosed to persons with a "need to know," as defined in 49 CFR parts 15 and 1520, except with the written permission of the Administrator of the Transportation Security Administration or the Secretary of Transportation. Unauthorized release may result in civil penalty or other action. For U.S. government agencies, public disclosure is governed by 5 U.S.C. 552 and 49 CFR parts 15 and 1520.

ILLUMINATION	SIGN TYPE	SIGN FUNCTION	MOUNTING METHOD	GENERAL DESCRIPTION & USE
REFLECTIVE / DYNAMIC LED	5-DR.10	DIRECTIONAL	FASCIA MOUNT	VEHICULAR - Primary Garage Entrance Directional

GENERAL NOTES

- All final design, engineering, and amount/sizing of structural sign support elements, material types/thicknesses, dimensions, and attachment methods shall be performed and approved by a licensed engineer to meet or exceed all applicable local and national codes.
- Final engineering, dimensions, materials, and fabrication are the responsibility of the Fabricator to ensure the highest quality fit and finish for all components of the completed product. All final detailing and specifications to be provided by the Fabricator within their final approved fabrication-ready shop drawings.
- Wherever dissimilar metals are in contact, always separate contact surfaces prior to assembly or installation with the necessary protective coatings/gaskets/washers to prevent galvanic corrosion.
- Final fabrication methods, quality and fit/finish to be reviewed and approved by DFW Planning Department and wayfinding/architecture Design Consultants thru prototype reviews prior to final production run/installation processes (see Performance Specifications for details).
- Colors shown are for reference only, and are subject to the limitations of the printing process and/or variance of electronic RGB screen displays. Refer to color system swatches and/or final finish samples for accurate reference.
- Messages shown here are general placeholders only. See graphic message schedules for specific messaging by location and sign type.

FABRICATION INTENT NOTES

- F1** OVERHEAD SIGN MOUNTING STRUCTURE: TXDOT overhead sign mounting structure, mounted to existing architectural building structures (determined per sign location); designed, engineered and installed by others per all TXDOT/MUTCD requirements; all structural attachment, sizing, type, amount and electrical feeds/components to be determined and engineered by a licensed engineer to meet or exceed all applicable codes
- F2** OVERHEAD SIGN PANELS: Standard TXDOT 12'H fabricated aluminum sign panel face U-extrusions mechanically fastened edge-to-edge to create overall sign face panel; cut ends curved to match sign face appearance as shown here; overall sign face unit mechanically fastened to standard 2nd surface TXDOT aluminum support frame/ribbing/structure; extrusions covered with 1st surface applied full-bleed 3M Reflective DG3 4090 White film with digitally printed color graphics (i.e. Picasso printer); graphics to be aligned vertically/horizontally as required for seamless graphic presentation as shown; sign element attachment, sizing, type, amount and electrical feeds/components to be determined and engineered by a licensed engineer to meet or exceed all applicable codes
- F3** DYNAMIC SPACE COUNT UNIT: match existing product used in latest garage improvement programs (or DFW Airport approved equivalent)

GRAPHICS / COLORS / DECORATION NOTES

- L1** Typeface: font = Clearview/Text Medium
 - S1** Universal Symbols: AIGA/TXDOT style symbol artwork
 - S3** Veh. Arrow(s): use only official MUTCD/TXDOT arrow art
- VINYL (FILM):
- V7** White: 3M 4090 DG3 White (Reflective)
 - V8** Yellow: 3M 4091 DG3 Yellow (Reflective)
 - V9** Blue: 3M 4095 DG3 Blue (Reflective)

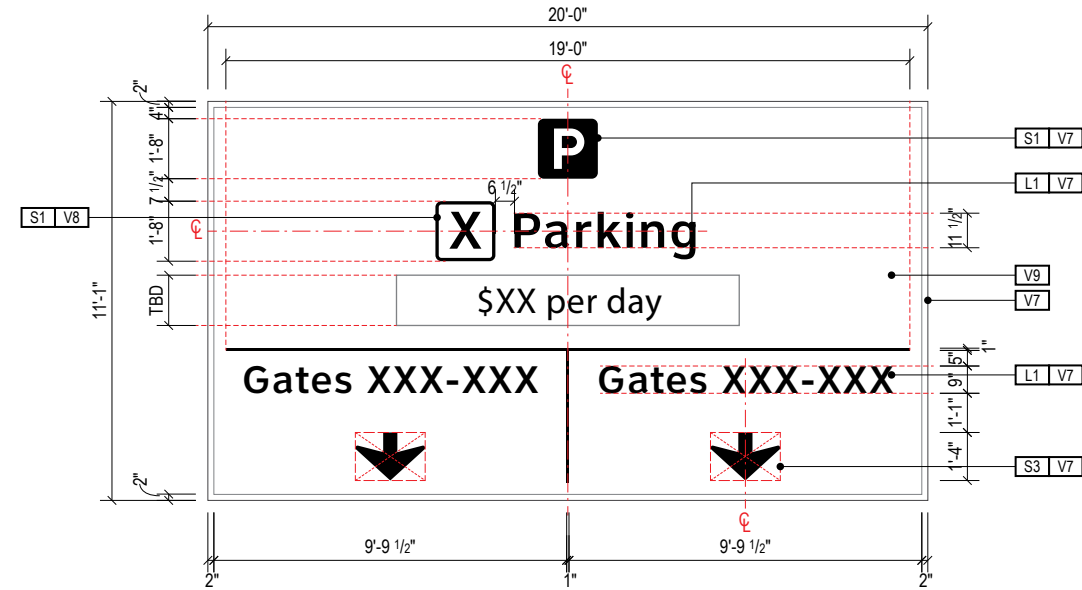

A FACE LAYOUT
Scale: 3/16" = 1'-0"

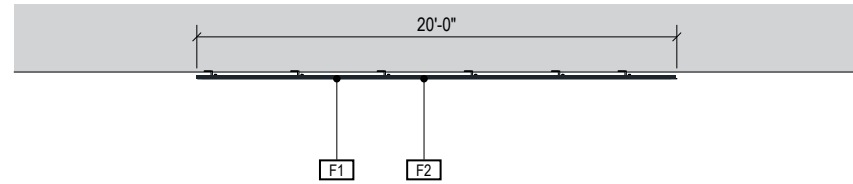

1 PLAN VIEW
Scale: 1/8" = 1'-0"

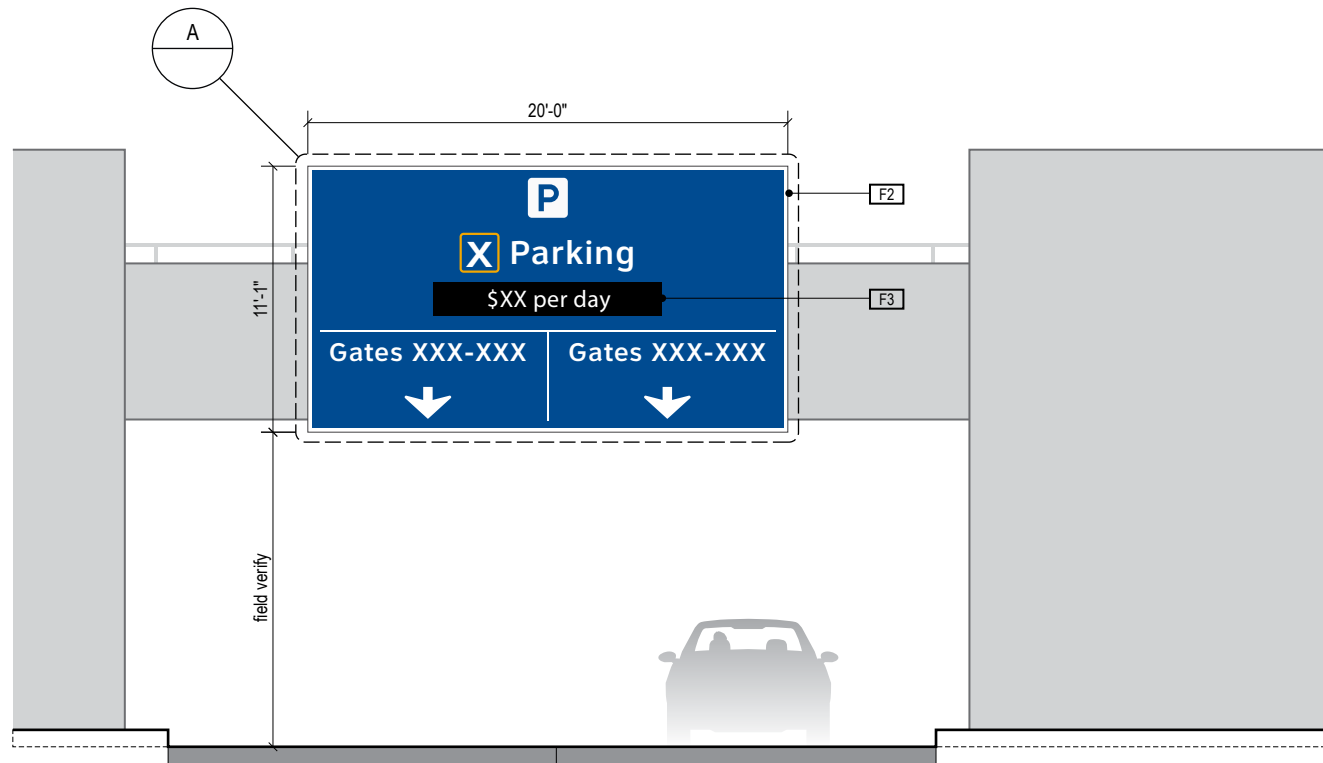

2 ELEVATION
Scale: 1/8" = 1'-0"

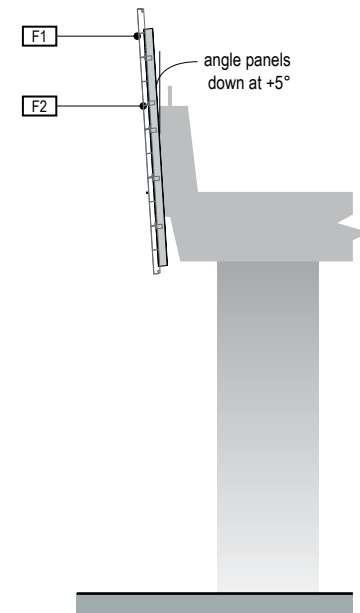

3 ELEVATION
Scale: 1/8" = 1'-0"

WARNING:

This record contains Sensitive Security Information that is controlled under 49 CFR parts 15 and 1520. No part of this record may be disclosed to persons with a "need to know," as defined in 49 CFR parts 15 and 1520, except with the written permission of the Administrator of the Transportation Security Administration or the Secretary of Transportation. Unauthorized release may result in civil penalty or other action. For U.S. government agencies, public disclosure is governed by 5 U.S.C. 552 and 49 CFR parts 15 and 1520.

ILLUMINATION	SIGN TYPE	SIGN FUNCTION	MOUNTING METHOD	GENERAL DESCRIPTION & USE
INTERNAL	5-ID.21	IDENTIFICATION	SUSPENDED	Ceiling Suspended Entry ID

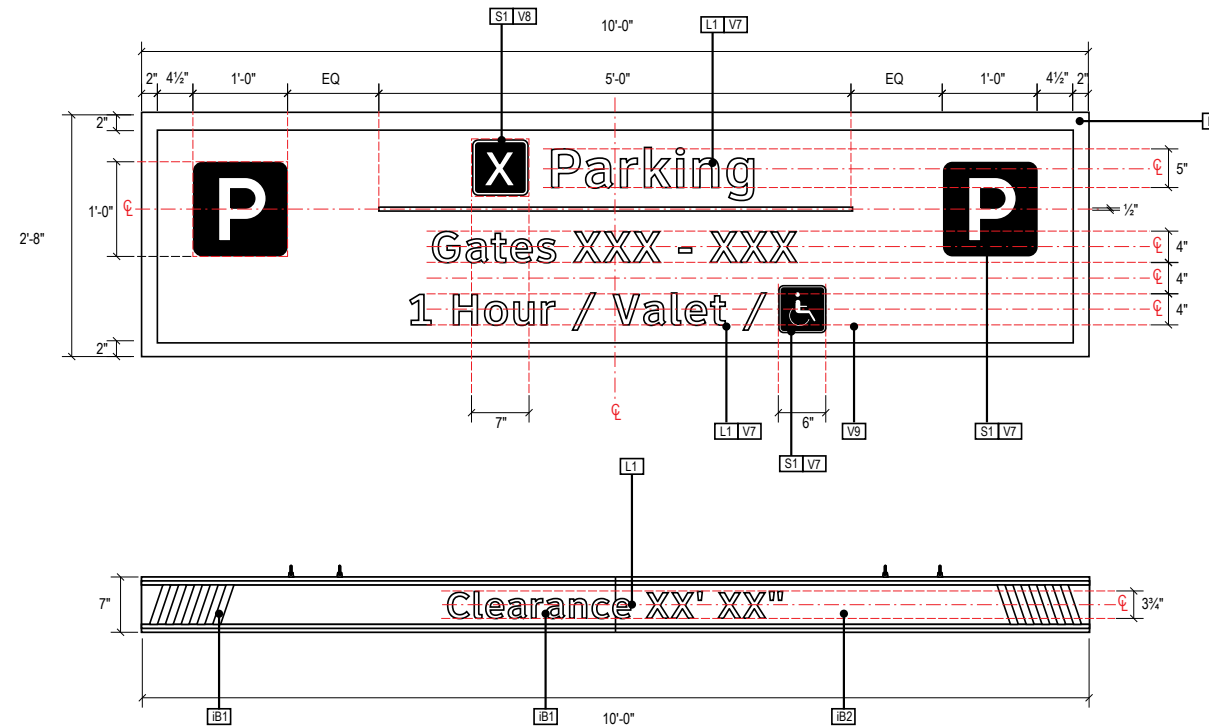

A DETAIL A: FACE LAYOUT
Scale: 1/4" = 1'-0"

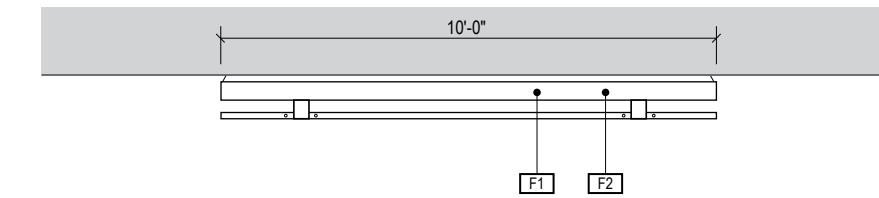

1 PLAN VIEW
Scale: 1/8" = 1'-0"

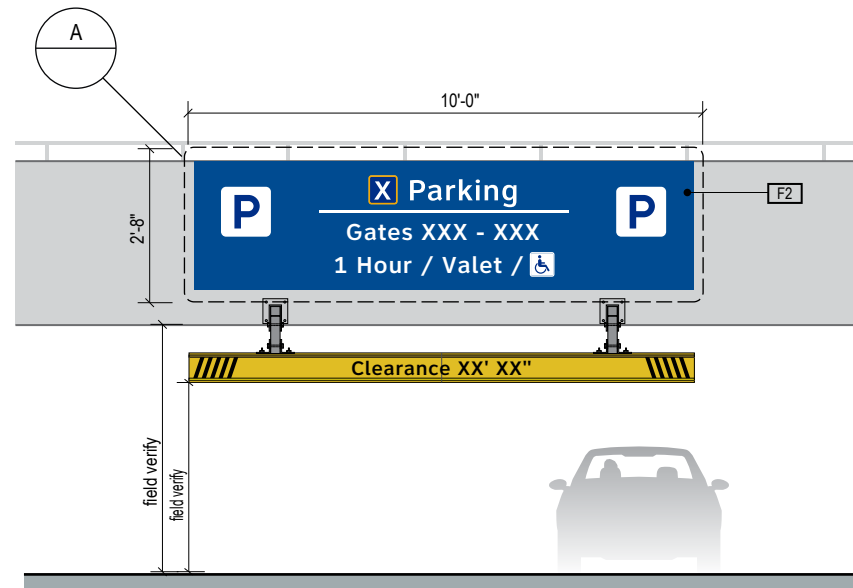

2 ELEVATION
Scale: 1/8" = 1'-0"

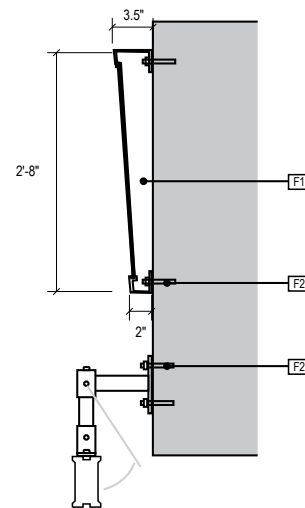

1 END VIEW
Scale: 1/4" = 1'-0"

GENERAL NOTES

- All final design, engineering, and amount/sizing of structural sign support elements, material types/thicknesses, dimensions, and attachment methods shall be performed and approved by a licensed engineer to meet or exceed all applicable local and national codes.
- Final engineering, dimensions, materials, and fabrication are the responsibility of the Fabricator to ensure the highest quality fit and finish for all components of the completed product. All final detailing and specifications to be provided by the Fabricator within their final approved fabrication-ready shop drawings.
- Wherever dissimilar metals are in contact, always separate contact surfaces prior to assembly or installation with the necessary protective coatings/gaskets/washers to prevent galvanic corrosion.
- Final fabrication methods, quality and fit/finish to be reviewed and approved by DFW Planning Department and wayfinding/architecture Design Consultants thru prototype reviews prior to final production run/installation processes (see Performance Specifications for details).
- Colors shown are for reference only, and are subject to the limitations of the printing process and/or variance of electronic RGB screen displays. Refer to color system swatches and/or final finish samples for accurate reference.
- Messages shown here are general placeholders only. See graphic message schedules for specific messaging by location and sign type.

FABRICATION INTENT NOTES

- F1** OVERHEAD SIGN MOUNTING STRUCTURE: TXDOT overhead sign mounting structure, mounted to existing architectural building structures (determined per sign location); designed, engineered and installed by others per all TXDOT/MUTCD requirements; all structural attachment, sizing, type, amount and electrical feeds/components to be determined and engineered by a licensed engineer to meet or exceed all applicable codes
- F2** OVERHEAD SIGN PANELS: Standard TXDOT 12"H fabricated aluminum sign panel face U-extrusions mechanically fastened edge-to-edge to create overall sign face panel; cut ends curved to match sign face appearance as shown here; overall sign face unit mechanically fastened to standard 2nd surface TXDOT aluminum support frame/ribbing/structure; extrusions covered with 1st surface applied full-bleed 3M Reflective DG3 4090 White film with digitally printed color graphics (i.e. Picasso printer); graphics to be aligned vertically/horizontally as required for seamless graphic presentation as shown all sign element attachment, sizing, type, amount and electrical feeds/components to be determined and engineered by a licensed engineer to meet or exceed all applicable codes

GRAPHICS / COLORS / DECORATION NOTES

- L1** Typeface: font = Clearview/Text Medium
 - S1** Universal Symbols: AIGA/TXDOT style symbol artwork
 - S3** Veh. Arrow(s): use only official MUTCD/TXDOT arrow art
- VINYL (FILM):
- V7** White: 3M 4090 DG3 White (Reflective)
 - V8** Yellow: 3M 4091 DG3 Yellow (Reflective)
 - V9** Blue: 3M 4095 DG3 Blue (Reflective)

WARNING:

This record contains Sensitive Security Information that is controlled under 49 CFR parts 15 and 1520. No part of this record may be disclosed to persons with a "need to know," as defined in 49 CFR parts 15 and 1520, except with the written permission of the Administrator of the Transportation Security Administration or the Secretary of Transportation. Unauthorized release may result in civil penalty or other action. For U.S. government agencies, public disclosure is governed by 5 U.S.C. 552 and 49 CFR parts 15 and 1520.

ILLUMINATION	SIGN TYPE	SIGN FUNCTION	MOUNTING METHOD	GENERAL DESCRIPTION & USE
INTERNAL	5-ID.21	IDENTIFICATION	WALL MOUNTED	Garage Entry Clearance Sign

GENERAL NOTES

- All final design, engineering, and amount/sizing of structural sign support elements, material types/thicknesses, dimensions, and attachment methods shall be performed and approved by a licensed engineer to meet or exceed all applicable local and national codes.
- Final engineering, dimensions, materials, and fabrication are the responsibility of the Fabricator to ensure the highest quality fit and finish for all components of the completed product. All final detailing and specifications to be provided by the Fabricator within their final approved fabrication-ready shop drawings.
- Wherever dissimilar metals are in contact, always separate contact surfaces prior to assembly or installation with the necessary protective coatings/gaskets/washers to prevent galvanic corrosion.
- Final fabrication methods, quality and fit/finish to be reviewed and approved by DFW Planning Department and wayfinding/architecture Design Consultants thru prototype reviews prior to final production run/installation processes (see Performance Specifications for details).
- Colors shown are for reference only, and are subject to the limitations of the printing process and/or variance of electronic RGB screen displays. Refer to color system swatches and/or final finish samples for accurate reference.
- Messages shown here are general placeholders only. See graphic message schedules for specific messaging by location and sign type.

FABRICATION INTENT NOTES

- F1** OVERHEAD SIGN MOUNTING STRUCTURE: TXDOT overhead sign mounting structure, mounted to existing architectural building structures (determined per sign location); designed, engineered and installed by others per all TXDOT/MUTCD requirements; all structural attachment, sizing, type, amount and electrical feeds/components to be determined and engineered by a licensed engineer to meet or exceed all applicable codes
- F2** OVERHEAD SIGN PANELS: Standard TXDOT 12"H fabricated aluminum sign panel face U-extrusions mechanically fastened edge-to-edge to create overall sign face panel; cut ends curved to match sign face appearance as shown here; overall sign face unit mechanically fastened to standard 2nd surface TXDOT aluminum support frame/ribbing/structure; extrusions covered with 1st surface applied full-bleed 3M Reflective DG3 4090 White film with digitally printed color graphics (i.e. Picasso printer); graphics to be aligned vertically/horizontally as required for seamless graphic presentation as shown; sign element attachment, sizing, type, amount and electrical feeds/components to be determined and engineered by a licensed engineer to meet or exceed all applicable codes

GRAPHICS / COLORS / DECORATION NOTES

- L1** Typeface: font = Clearview/Text Medium
 - S1** Universal Symbols: AIGA/TXDOT style symbol artwork
 - S3** Veh. Arrow(s): use only official MUTCD/TXDOT arrow art
- VINYL (FILM):
- V7** White: 3M 4090 DG3 White (Reflective)
 - V8** Yellow: 3M 4091 DG3 Yellow (Reflective)
 - V9** Blue: 3M 4095 DG3 Blue (Reflective)

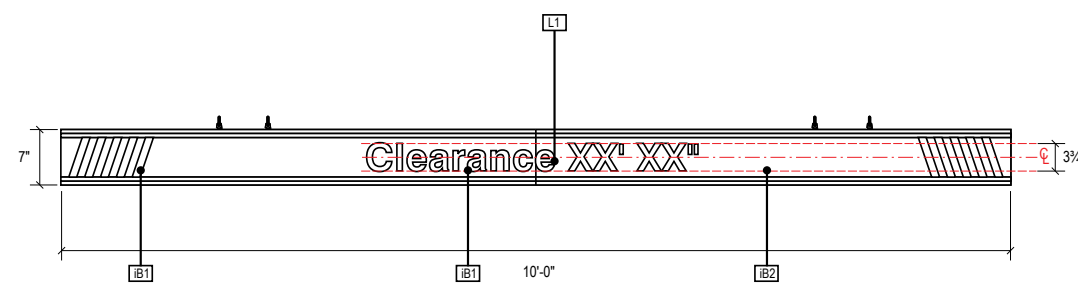
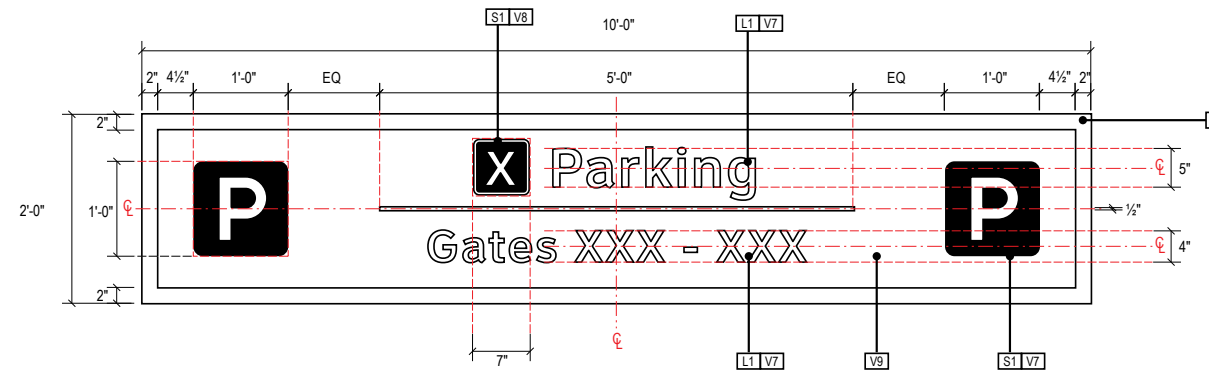

A DETAIL A: FACE LAYOUT
Scale: 1/4" = 1'-0"

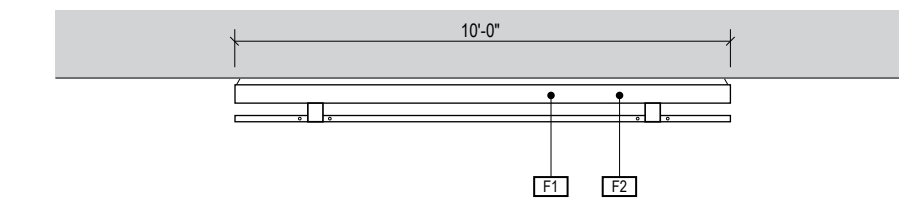

1 PLAN VIEW
Scale: 1/8" = 1'-0"

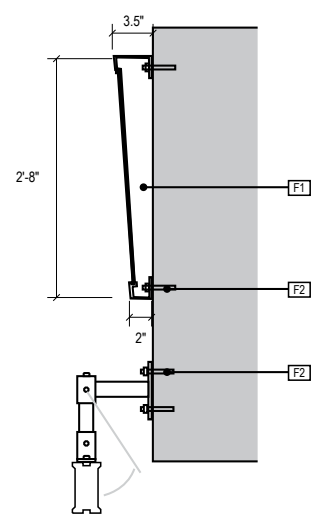

1 END VIEW
Scale: 1/4" = 1'-0"

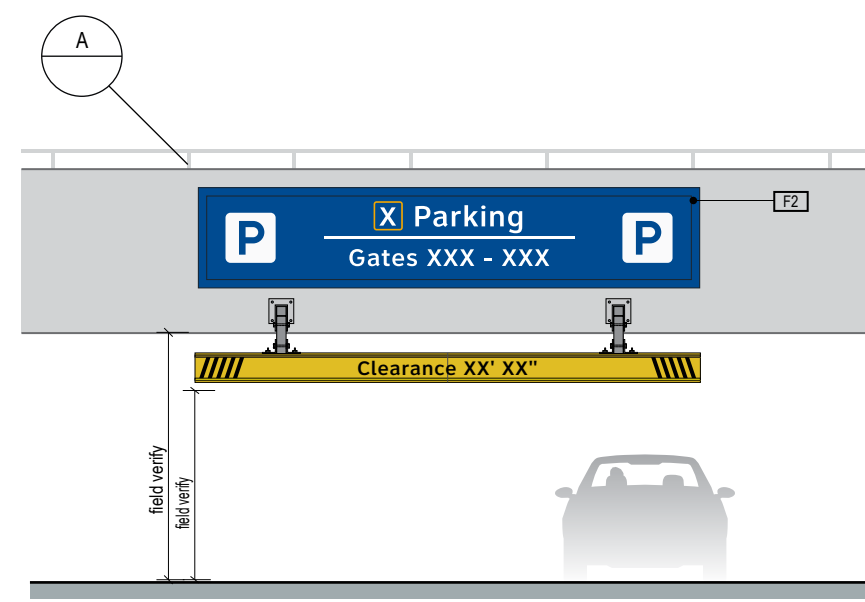

2 ELEVATION
Scale: 1/8" = 1'-0"

ILLUMINATION	SIGN TYPE	SIGN FUNCTION	MOUNTING METHOD	GENERAL DESCRIPTION & USE
INTERNAL	5-ID.22	IDENTIFICATION	WALL MOUNTED	Garage Entry Clearance Sign

GENERAL NOTES

- All final design, engineering, and amount/sizing of structural sign support elements, material types/thicknesses, dimensions, and attachment methods shall be performed and approved by a licensed engineer to meet or exceed all applicable local and national codes.
- Final engineering, dimensions, materials, and fabrication are the responsibility of the Fabricator to ensure the highest quality fit and finish for all components of the completed product. All final detailing and specifications to be provided by the Fabricator within their final approved fabrication-ready shop drawings.
- Wherever dissimilar metals are in contact, always separate contact surfaces prior to assembly or installation with the necessary protective coatings/gaskets/washers to prevent galvanic corrosion.
- Final fabrication methods, quality and fit/finish to be reviewed and approved by DFW Planning Department and wayfinding/architecture Design Consultants thru prototype reviews prior to final production run/installation processes (see Performance Specifications for details).
- Colors shown are for reference only, and are subject to the limitations of the printing process and/or variance of electronic RGB screen displays. Refer to color system swatches and/or final finish samples for accurate reference.
- Messages shown here are general placeholders only. See graphic message schedules for specific messaging by location and sign type.

FABRICATION INTENT NOTES

- F1** OVERHEAD SIGN MOUNTING STRUCTURE: TXDOT overhead sign mounting structure, mounted to existing architectural building structures (determined per sign location); designed, engineered and installed by others per all TXDOT/MUTCD requirements; all structural attachment, sizing, type, amount and electrical feeds/components to be determined and engineered by a licensed engineer to meet or exceed all applicable codes
- F2** OVERHEAD SIGN PANELS: Standard TXDOT 12"H fabricated aluminum sign panel face U-extrusions mechanically fastened edge-to-edge to create overall sign face panel; cut ends curved to match sign face appearance as shown here; overall sign face unit mechanically fastened to standard 2nd surface TXDOT aluminum support frame/ribbing/structure; extrusions covered with 1st surface applied full-bleed 3M Reflective DG3 4090 White film with digitally printed color graphics (i.e. Picasso printer); graphics to be aligned vertically/horizontally as required for seamless graphic presentation as shown/all sign element attachment, sizing, type, amount and electrical feeds/components to be determined and engineered by a licensed engineer to meet or exceed all applicable codes

GRAPHICS / COLORS / DECORATION NOTES

- L1** Typeface: font = Clearview/Text Medium
 - S1** Universal Symbols: AIGA/TXDOT style symbol artwork
 - S3** Veh. Arrow(s): use only official MUTCD/TXDOT arrow art
- VINYL (FILM):
- V7** White: 3M 4090 DG3 White (Reflective)
 - V8** Yellow: 3M 4091 DG3 Yellow (Reflective)
 - V9** Blue: 3M 4095 DG3 Blue (Reflective)

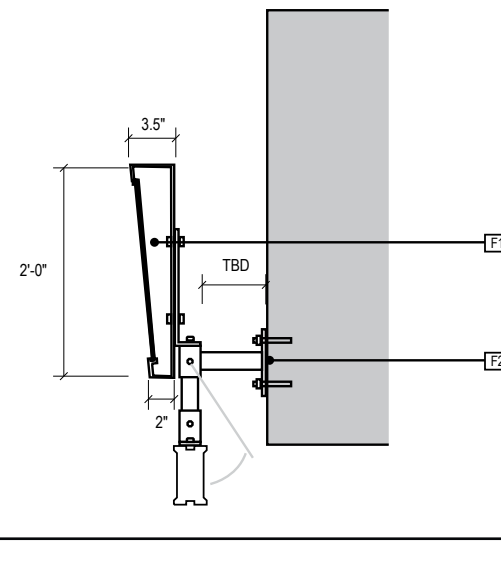
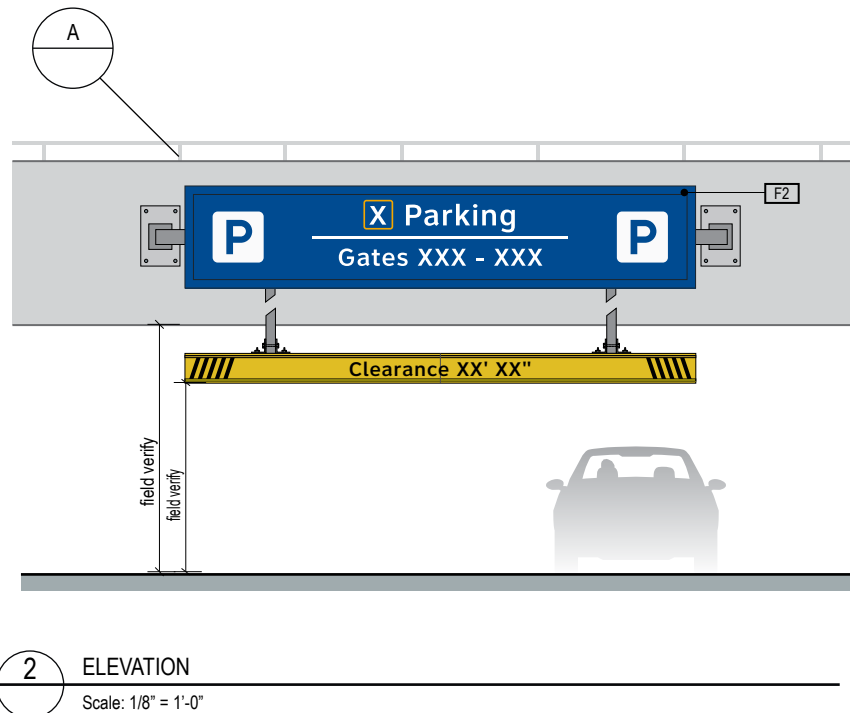
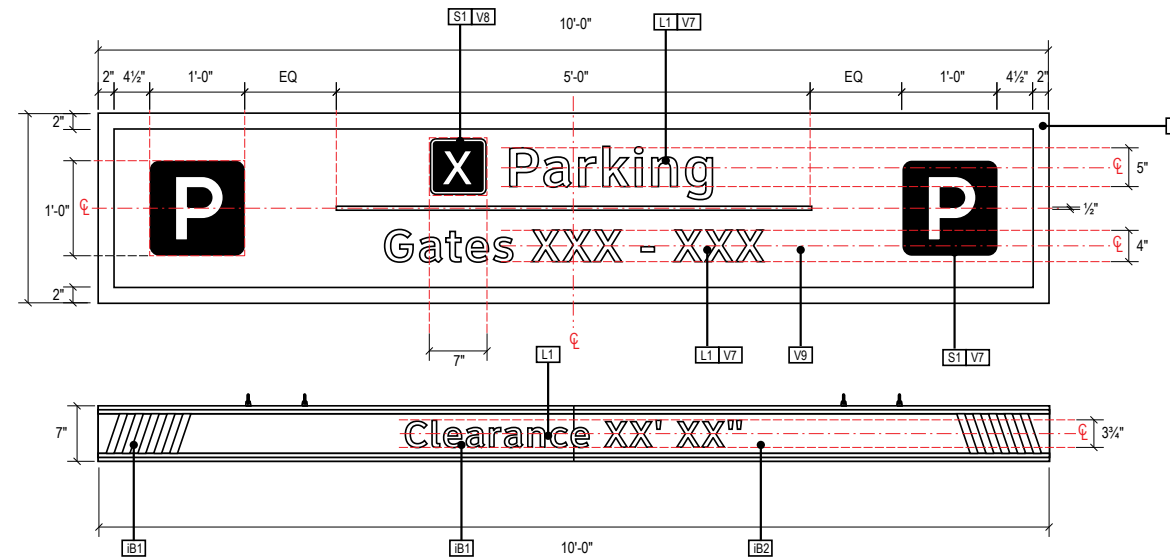
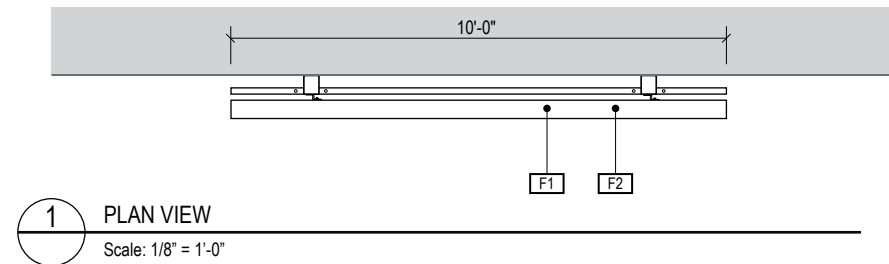

WARNING:

This record contains Sensitive Security Information that is controlled under 49 CFR parts 15 and 1520. No part of this record may be disclosed to persons with a "need to know," as defined in 49 CFR parts 15 and 1520, except with the written permission of the Administrator of the Transportation Security Administration or the Secretary of Transportation. Unauthorized release may result in civil penalty or other action. For U.S. government agencies, public disclosure is governed by 5 U.S.C. 552 and 49 CFR parts 15 and 1520.

ILLUMINATION	SIGN TYPE	SIGN FUNCTION	MOUNTING METHOD	GENERAL DESCRIPTION & USE
REFLECTIVE	5-DR.11	DIRECTIONAL	FASCIA MOUNT	VEHICULAR - Garage Entry Lane Directional

GENERAL NOTES

- All final design, engineering, and amount/sizing of structural sign support elements, material types/thicknesses, dimensions, and attachment methods shall be performed and approved by a licensed engineer to meet or exceed all applicable local and national codes.
- Final engineering, dimensions, materials, and fabrication are the responsibility of the Fabricator to ensure the highest quality fit and finish for all components of the completed product. All final detailing and specifications to be provided by the Fabricator within their final approved fabrication-ready shop drawings.
- Wherever dissimilar metals are in contact, always separate contact surfaces prior to assembly or installation with the necessary protective coatings/gaskets/washers to prevent galvanic corrosion.
- Final fabrication methods, quality and fit/finish to be reviewed and approved by DFW Planning Department and wayfinding/architecture Design Consultants thru prototype reviews prior to final production run/installation processes (see Performance Specifications for details).
- Colors shown are for reference only, and are subject to the limitations of the printing process and/or variance of electronic RGB screen displays. Refer to color system swatches and/or final finish samples for accurate reference.
- Messages shown here are general placeholders only. See graphic message schedules for specific messaging by location and sign type.

FABRICATION INTENT NOTES

- F1** OVERHEAD SIGN MOUNTING STRUCTURE: TXDOT overhead sign mounting structure, mounted to existing architectural building structures (determined per sign location); designed, engineered and installed by others per all TXDOT/MUTCD requirements; all structural attachment, sizing, type, amount and electrical feeds/components to be determined and engineered by a licensed engineer to meet or exceed all applicable codes
- F2** OVERHEAD SIGN PANELS: Standard TXDOT 12'H fabricated aluminum sign panel face U-extrusions mechanically fastened edge-to-edge to create overall sign face panel; cut ends curved to match sign face appearance as shown here; overall sign face unit mechanically fastened to standard 2nd surface TXDOT aluminum support frame/ribbing/structure; extrusions covered with 1st surface applied full-bleed 3M Reflective DG3 4090 White film with digitally printed color graphics (i.e. Picasso printer); graphics to be aligned vertically/horizontally as required for seamless graphic presentation as shown; sign element attachment, sizing, type, amount and electrical feeds/components to be determined and engineered by a licensed engineer to meet or exceed all applicable codes

GRAPHICS / COLORS / DECORATION NOTES

- L1** Typeface: font = ClearviewText Medium
- S1** Universal Symbols: AIGA/TXDOT style symbol artwork
- S3** Veh. Arrow(s): use only official MUTCD/TXDOT arrow art
- VINYL (FILM):
- V7** White: 3M 4090 DG3 White (Reflective)
- V9** Blue: 3M 4095 DG3 Blue (Reflective)

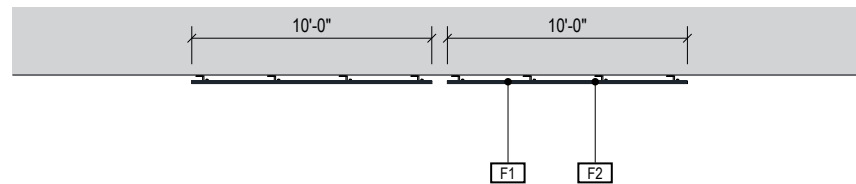

1 PLAN VIEW
Scale: 1/8" = 1'-0"

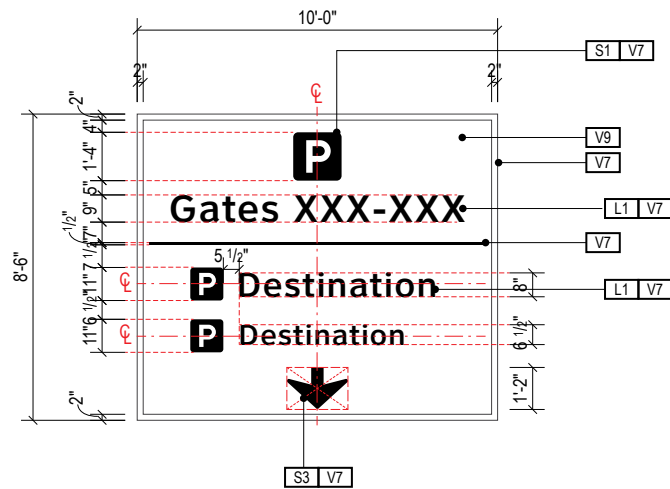

A FACE LAYOUT
Scale: 3/16" = 1'-0"

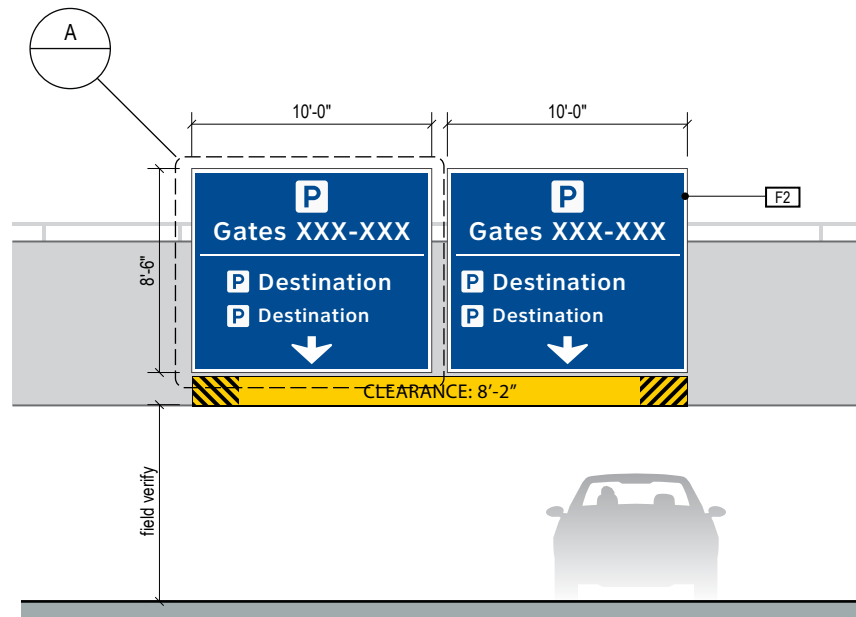

2 ELEVATION
Scale: 1/8" = 1'-0"

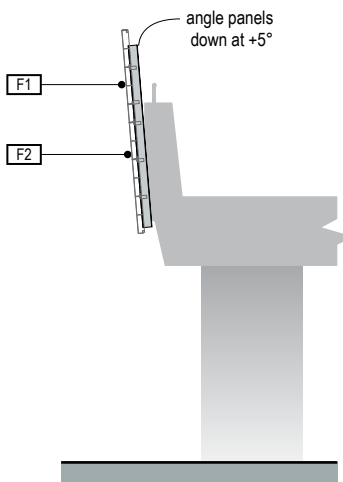

3 ELEVATION
Scale: 1/8" = 1'-0"

ILLUMINATION	SIGN TYPE	SIGN FUNCTION	MOUNTING METHOD	GENERAL DESCRIPTION & USE
REFLECTIVE	5-ID.24	IDENTIFICATION	BEAM/WALL	Inside Garage Clearance Sign

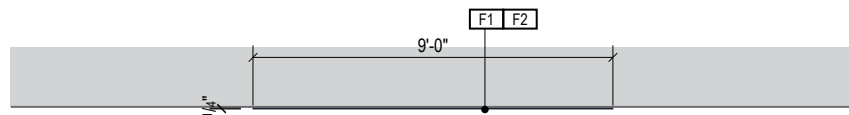

1 PLAN VIEW
Scale: 3/16" = 1'-0"

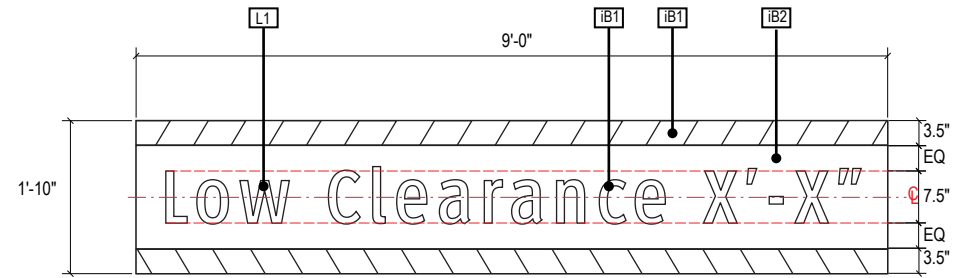

A FACE LAYOUT
Scale: 1/2" = 1'-0"

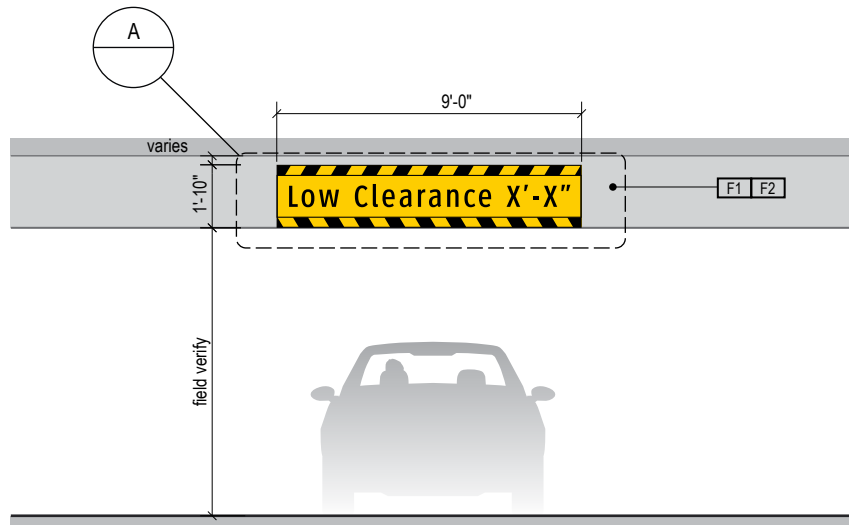

2 ELEVATION
Scale: 3/16" = 1'-0"

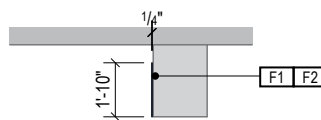

3 END VIEW
Scale: 3/16" = 1'-0"

GENERAL NOTES

- All final design, engineering, and amount/sizing of structural sign support elements, material types/thicknesses, dimensions, and attachment methods shall be performed and approved by a licensed engineer to meet or exceed all applicable local and national codes.
- Final engineering, dimensions, materials, and fabrication are the responsibility of the Fabricator to ensure the highest quality fit and finish for all components of the completed product. All final detailing and specifications to be provided by the Fabricator within their final approved fabrication-ready shop drawings.
- Wherever dissimilar metals are in contact, always separate contact surfaces prior to assembly or installation with the necessary protective coatings/gaskets/washers to prevent galvanic corrosion.
- Final fabrication methods, quality and fit/finish to be reviewed and approved by DFW Airport Planning Department and wayfinding/architecture Design Consultants thru prototype reviews prior to final production run/installation processes (see Performance Specifications for details).
- Colors shown are for reference only, and are subject to the limitations of the printing process and/or variance of electronic RGB screen displays. Refer to color system swatches and/or final finish samples for accurate reference.
- Messages shown here are general placeholders only. See graphic message schedules for specific messaging by location and sign type.

FABRICATION INTENT NOTES

- F1** SIGN CABINET/FRAME: modular fabricated internal illuminated edge-lit sign module cabinet constructed of extruded aluminum and cast aluminum components with concealed internal welds; removable sign face and light modules; fabricated aluminum support frame with welded mitered corners and slotted mounting holes to accept sign mounting brackets; fabricated aluminum sign mounting frame with tapered side end cover panels, attached with aluminum pin and clip system; power feed/units hidden behind mounting frame with access holes in back for wall mounting; powdercoat all exposed surfaces of sign cabinet/support frame/mounting frame to match P1, satin finish
- F2** SIGN FACE: fabricated sign face assembly module constructed of extruded aluminum frame and concealed internal welds; faces are 3/16" white acrylic with 1st surface applied V1 vinyl film, graphics reversed out of blue (white is exposed white acrylic cut-thru blue film); faces illuminated with light panel assembly using LED edge-lit clear inscribed acrylic diffuser and self-contained technology (including electronics, extruded frame and diffuser)
- F3** TRIM: .080 fabricated aluminum trim piece with closed ends; detachable and mounted with keyholes/studs and set screws; paint all exposed surfaces to match P2, satin finish
- F4** MOUNTING: mount to wall structural elements with connection system as installation location conditions require (Fabricator to coordinate connection location/type of structural elements with General Contractor); paint all exposed surfaces to match P1, satin finish

GRAPHICS / COLORS / DECORATION NOTES

- L1** Typeface: font = ClearviewText Medium
- L2** Typeface: font = ClearviewText Bold
- S1** Universal Symbols: AIGATXDOT style symbol artwork
- S3** Veh. Arrow(s): use only official MUTCD/TXDOT arrow art

VINYL (FILM) / DIGITAL PRINT:

- V7** White: 3M 4090 DG3 White (Reflective)
- V8** Yellow: 3M 4091 DG3 Yellow (Reflective)
- V9** Blue: 3M 4095 DG3 Blue (Reflective)
- IB1** Black reflective vinyl (7803)
- IB2** Powder coated Traffic Yellow

WARNING:

This record contains Sensitive Security Information that is controlled under 49 CFR parts 15 and 1520. No part of this record may be disclosed to persons with a "need to know," as defined in 49 CFR parts 15 and 1520, except with the written permission of the Administrator of the Transportation Security Administration or the Secretary of Transportation. Unauthorized release may result in civil penalty or other action. For U.S. government agencies, public disclosure is governed by 5 U.S.C. 552 and 49 CFR parts 15 and 1520.

ILLUMINATION	SIGN TYPE	SIGN FUNCTION	MOUNTING METHOD	GENERAL DESCRIPTION & USE
REFLECTIVE	5-DR.13	DIRECTIONAL	BEAM/WALL	VEHICULAR - UP/DOWN Trailblazer; 1 direction; 1 side

GENERAL NOTES

- All final design, engineering, and amount/sizing of structural sign support elements, material types/thicknesses, dimensions, and attachment methods shall be performed and approved by a licensed engineer to meet or exceed all applicable local and national codes.
- Final engineering, dimensions, materials, and fabrication are the responsibility of the Fabricator to ensure the highest quality fit and finish for all components of the completed product. All final detailing and specifications to be provided by the Fabricator within their final approved fabrication-ready shop drawings.
- Wherever dissimilar metals are in contact, always separate contact surfaces prior to assembly or installation with the necessary protective coatings/gaskets/washers to prevent galvanic corrosion.
- Final fabrication methods, quality and fit/finish to be reviewed and approved by DFW Planning Department and wayfinding/architecture Design Consultants thru prototype reviews prior to final production run/installation processes (see Performance Specifications for details).
- Colors shown are for reference only, and are subject to the limitations of the printing process and/or variance of electronic RGB screen displays. Refer to color system swatches and/or final finish samples for accurate reference.
- Messages shown here are general placeholders only. See graphic message schedules for specific messaging by location and sign type.

FABRICATION INTENT NOTES

- F1** SIGN FACE PANELS: 1/4" thick aluminum sign face panels; digitally printed full-bleed color graphics on 3M Reflective DG3 4090 White film applied to 1st surface of face panels; all exposed surfaces and returns to be painted with MAP paint to match P1, satin finish
- F2** MOUNTING: mechanically fasten sign panels to wall/beam/soffit with stainless steel tamper-proof mechanical fasteners as install conditions require (Fabricator to field verify), paint heads to match sign face; NOTE: Fabricator to use proper connection gaskets/seals/etc to eliminate corrosion from mounting surface and weather conditions as install location conditions require (Fabricator to field verify)

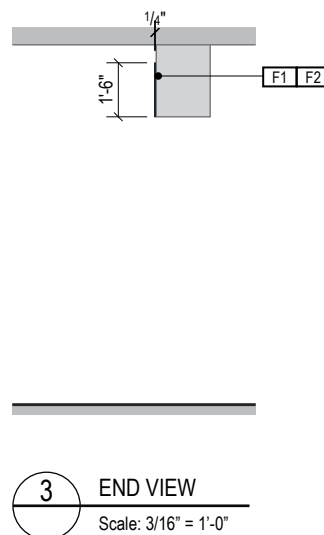
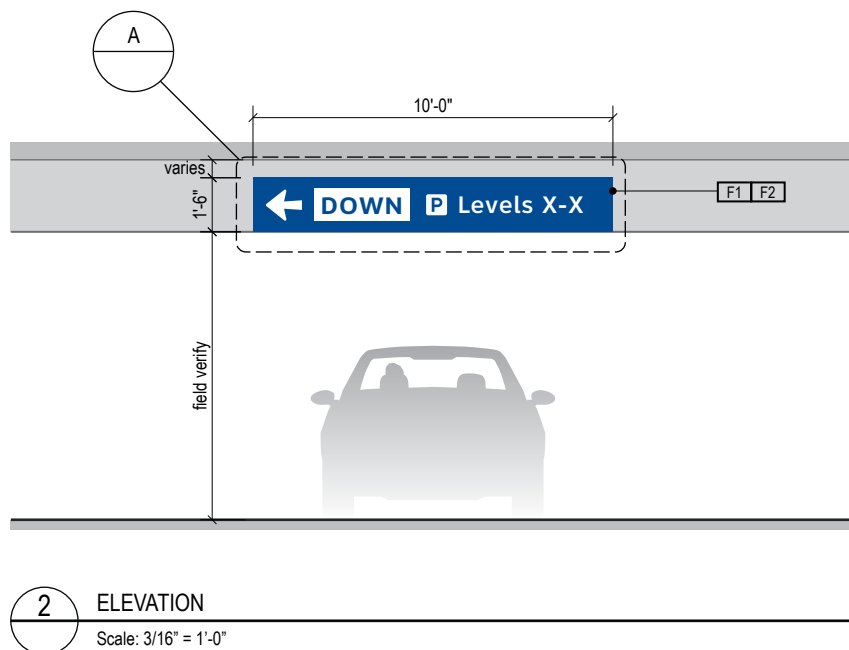
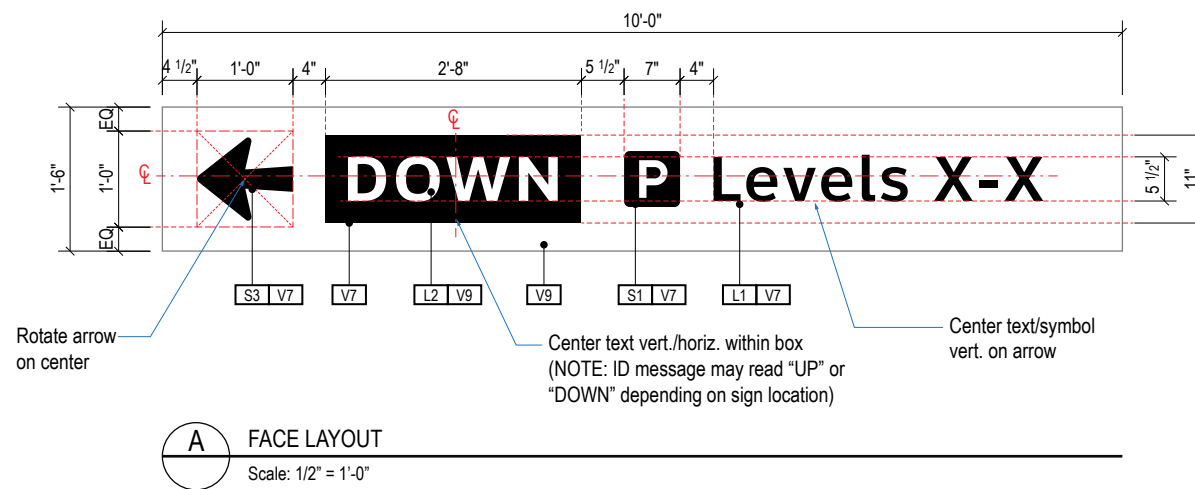
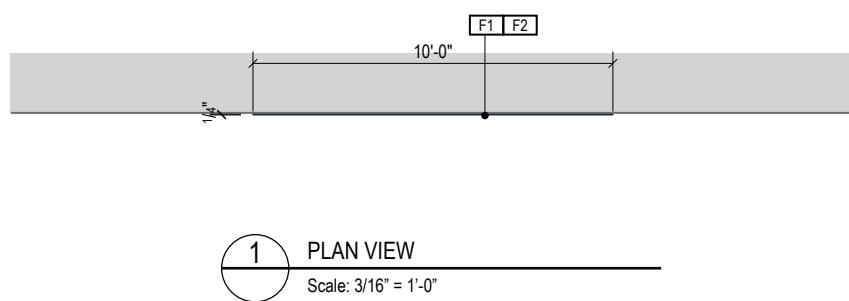

GRAPHICS / COLORS / DECORATION NOTES

- L1** Typeface: font = ClearviewText Medium
 - L2** Typeface: font = ClearviewText Bold
 - S1** Universal Symbols: AIGA/TXDOT style symbol artwork
 - S3** Veh. Arrow(s): use only official MUTCD/TXDOT arrow art
- VINYL (FILM) / DIGITAL PRINT:
- V7** White: 3M 4090 DG3 White (Reflective)
 - V9** Blue: 3M 4095 DG3 Blue (Reflective)

ILLUMINATION	SIGN TYPE	SIGN FUNCTION	MOUNTING METHOD	GENERAL DESCRIPTION & USE
REFLECTIVE / DYNAMIC LED	5-DR.14	DIRECTIONAL	BEAM/WALL	VEHICULAR - Directional w/ Static & Dynamic message; 1 direction; 1 side

GENERAL NOTES

- All final design, engineering, and amount/sizing of structural sign support elements, material types/thicknesses, dimensions, and attachment methods shall be performed and approved by a licensed engineer to meet or exceed all applicable local and national codes.
- Final engineering, dimensions, materials, and fabrication are the responsibility of the Fabricator to ensure the highest quality fit and finish for all components of the completed product. All final detailing and specifications to be provided by the Fabricator within their final approved fabrication-ready shop drawings.
- Wherever dissimilar metals are in contact, always separate contact surfaces prior to assembly or installation with the necessary protective coatings/gaskets/washers to prevent galvanic corrosion.
- Final fabrication methods, quality and finish to be reviewed and approved by DFW Planning Department and wayfinding/architecture Design Consultants thru prototype reviews prior to final production run/installation processes (see Performance Specifications for details).
- Colors shown are for reference only, and are subject to the limitations of the printing process and/or variance of electronic RGB screen displays. Refer to color system swatches and/or final finish samples for accurate reference.
- Messages shown here are general placeholders only. See graphic message schedules for specific messaging by location and sign type.

FABRICATION INTENT NOTES

- F1** SIGN BOX: fabricated aluminum extrusion frame with removable aluminum face panels, all welds filled and ground smooth for seamless appearance; removable faces use internal hidden top aluminum panel clip and are mechanically fastened with countersunk S.S. screws at bottom returns edges of extrusion frame (paint screwheads to match returns) into internal aluminum angle; vertical support tubes mechanically fastened to top of sign box extrusion frame; digitally printed full-bleed color graphics on 3M Reflective DG3 4090 White film applied to 1st surface of face panels; all exposed surfaces, returns, etc to be painted with MAP paint to match P1, satin finish; routed cut-outs in face panels and vents in sign box sized per dynamic unit required
- F2** MOUNTING: mechanically fasten sign panels to wall/beam/soffit with stainless steel tamper-proof mechanical fasteners as install conditions require (Fabricator to field verify), paint heads to match sign face; NOTE: Fabricator to use proper connection gaskets/seals/etc to eliminate corrosion from mounting surface and weather conditions as install location conditions require (Fabricator to field verify)
- F3** DYNAMIC SPACE COUNT UNIT: By others

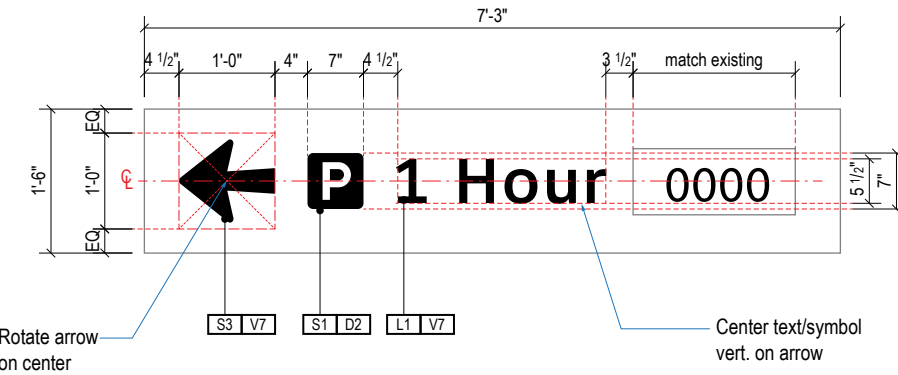

A FACE LAYOUT
Scale: 1/2" = 1'-0"

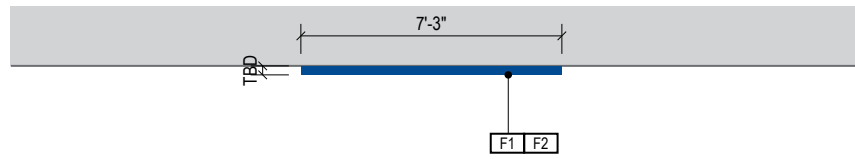

1 PLAN VIEW
Scale: 3/16" = 1'-0"

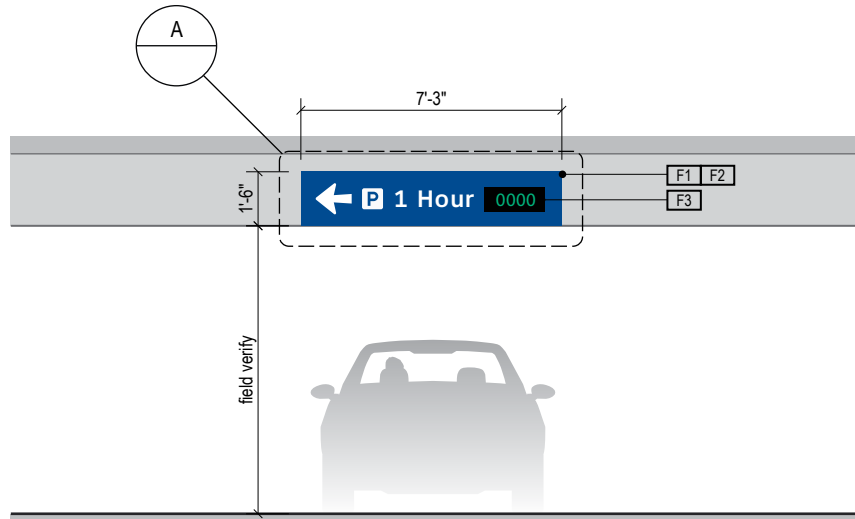

2 ELEVATION
Scale: 3/16" = 1'-0"

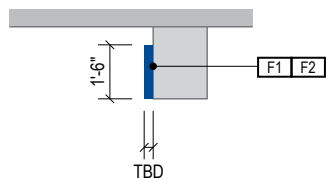

3 END VIEW
Scale: 3/16" = 1'-0"

GRAPHICS / COLORS / DECORATION NOTES

- L1** Typeface: font = ClearviewText Medium
 - S1** Universal Symbols: AIGA/TXDOT style symbol artwork
 - S3** Veh. Arrow(s): use only official MUTCD/TXDOT arrow art
- VINYL (FILM) / DIGITAL PRINT:
- V7** White: 3M 4090 DG3 White (Reflective)
 - V9** Blue: 3M 4095 DG3 Blue (Reflective)

WARNING:

This record contains Sensitive Security Information that is controlled under 49 CFR parts 15 and 1520. No part of this record may be disclosed to persons with a "need to know," as defined in 49 CFR parts 15 and 1520, except with the written permission of the Administrator of the Transportation Security Administration or the Secretary of Transportation. Unauthorized release may result in civil penalty or other action. For U.S. government agencies, public disclosure is governed by 5 U.S.C. 552 and 49 CFR parts 15 and 1520.

ILLUMINATION	SIGN TYPE	SIGN FUNCTION	MOUNTING METHOD	GENERAL DESCRIPTION & USE
REFLECTIVE	5-DR.15	DIRECTIONAL	BEAM/WALL	VEHICULAR - Valet Trailblazer; 1 direction; 1 side

GENERAL NOTES

- All final design, engineering, and amount/sizing of structural sign support elements, material types/thicknesses, dimensions, and attachment methods shall be performed and approved by a licensed engineer to meet or exceed all applicable local and national codes.
- Final engineering, dimensions, materials, and fabrication are the responsibility of the Fabricator to ensure the highest quality fit and finish for all components of the completed product. All final detailing and specifications to be provided by the Fabricator within their final approved fabrication-ready shop drawings.
- Wherever dissimilar metals are in contact, always separate contact surfaces prior to assembly or installation with the necessary protective coatings/gaskets/washers to prevent galvanic corrosion.
- Final fabrication methods, quality and fit/finish to be reviewed and approved by DFW Planning Department and wayfinding/architecture Design Consultants thru prototype reviews prior to final production run/installation processes (see Performance Specifications for details).
- Colors shown are for reference only, and are subject to the limitations of the printing process and/or variance of electronic RGB screen displays. Refer to color system swatches and/or final finish samples for accurate reference.
- Messages shown here are general placeholders only. See graphic message schedules for specific messaging by location and sign type.

FABRICATION INTENT NOTES

- F1** SIGN FACE PANELS: 1/4" thick aluminum sign face panels; digitally printed full-bleed color graphics on 3M Reflective DG3 4090 White film applied to 1st surface of face panels; all exposed surfaces and returns to be painted with MAP paint to match P1, satin finish
- F2** MOUNTING: mechanically fasten sign panels to wall/beam/soffit with stainless steel tamper-proof mechanical fasteners as install conditions require (Fabricator to field verify), paint heads to match sign face; NOTE: Fabricator to use proper connection gaskets/seals/etc to eliminate corrosion from mounting surface and weather conditions as install location conditions require (Fabricator to field verify)

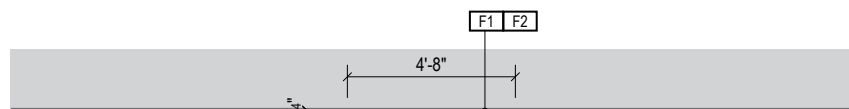

1 PLAN VIEW
Scale: 3/16" = 1'-0"

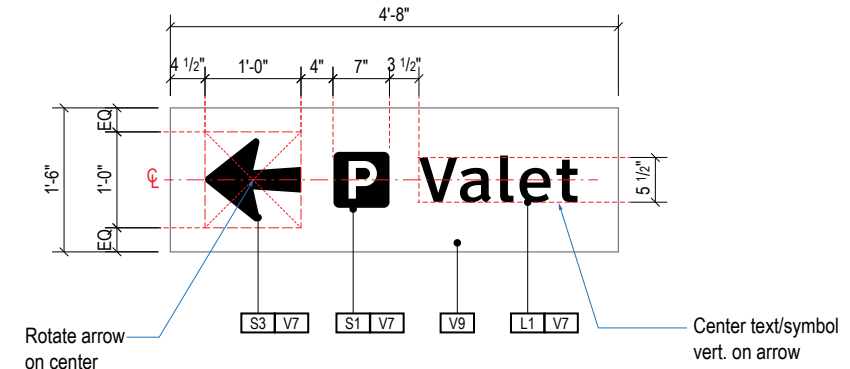

A FACE LAYOUT
Scale: 1/2" = 1'-0"

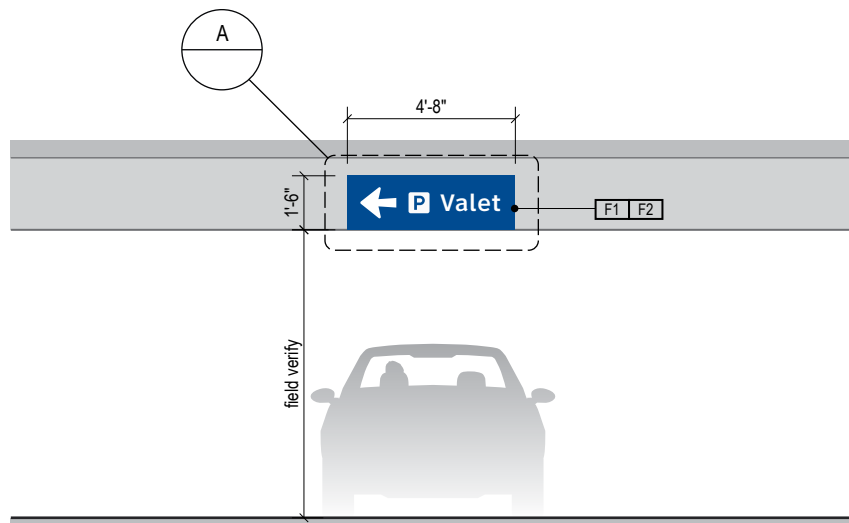

2 ELEVATION
Scale: 3/16" = 1'-0"

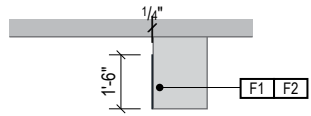

3 END VIEW
Scale: 3/16" = 1'-0"

GRAPHICS / COLORS / DECORATION NOTES

- L1** Typeface: font = ClearviewText Medium
- S1** Universal Symbols: AIGA/TXDOT style symbol artwork
- S3** Veh. Arrow(s): use only official MUTCD/TXDOT arrow art

VINYL (FILM) / DIGITAL PRINT:

- V7** White: 3M 4090 DG3 White (Reflective)
- V9** Blue: 3M 4095 DG3 Blue (Reflective)

WARNING:

This record contains Sensitive Security Information that is controlled under 49 CFR parts 15 and 1520. No part of this record may be disclosed to persons with a "need to know," as defined in 49 CFR parts 15 and 1520, except with the written permission of the Administrator of the Transportation Security Administration or the Secretary of Transportation. Unauthorized release may result in civil penalty or other action. For U.S. government agencies, public disclosure is governed by 5 U.S.C. 552 and 49 CFR parts 15 and 1520.

ILLUMINATION	SIGN TYPE	SIGN FUNCTION	MOUNTING METHOD	GENERAL DESCRIPTION & USE
REFLECTIVE / DYNAMIC LED	5-DR.16	DIRECTIONAL	BEAM/WALL	VEHICULAR - Space Count Directional; 1 direction; 1 side

GENERAL NOTES

- All final design, engineering, and amount/sizing of structural sign support elements, material types/thicknesses, dimensions, and attachment methods shall be performed and approved by a licensed engineer to meet or exceed all applicable local and national codes.
- Final engineering, dimensions, materials, and fabrication are the responsibility of the Fabricator to ensure the highest quality fit and finish for all components of the completed product. All final detailing and specifications to be provided by the Fabricator within their final approved fabrication-ready shop drawings.
- Wherever dissimilar metals are in contact, always separate contact surfaces prior to assembly or installation with the necessary protective coatings/gaskets/washers to prevent galvanic corrosion.
- Final fabrication methods, quality and finish to be reviewed and approved by DFW Planning Department and wayfinding/architecture Design Consultants thru prototype reviews prior to final production run/installation processes (see Performance Specifications for details).
- Colors shown are for reference only, and are subject to the limitations of the printing process and/or variance of electronic RGB screen displays. Refer to color system swatches and/or final finish samples for accurate reference.
- Messages shown here are general placeholders only. See graphic message schedules for specific messaging by location and sign type.

FABRICATION INTENT NOTES

- F1** SIGN BOX: fabricated aluminum extrusion frame with removable aluminum face panels, all welds filled and ground smooth for seamless appearance; removable faces use internal hidden top aluminum panel clip and are mechanically fastened with countersunk S.S. screws at bottom returns edges of extrusion frame (paint screwheads to match returns) into internal aluminum angle; vertical support tubes mechanically fastened to top of sign box extrusion frame; digitally printed full-bleed color graphics on 3M Reflective DG3 4090 White film applied to 1st surface of face panels; all exposed surfaces, returns, etc to be painted with MAP paint to match P1, satin finish; routed cut-outs in face panels and vents in sign box sized per dynamic unit required
- F2** MOUNTING: mechanically fasten sign panels to wall/beam/soffit with stainless steel tamper-proof mechanical fasteners as install conditions require (Fabricator to field verify), paint heads to match sign face; NOTE: Fabricator to use proper connection gaskets/seals/etc to eliminate corrosion from mounting surface and weather conditions as install location conditions require (Fabricator to field verify)
- F3** DYNAMIC SPACE COUNT UNIT: By others

GRAPHICS / COLORS / DECORATION NOTES

- L1** Typeface: font = ClearviewText Medium
- L2** Typeface: font = ClearviewText Bold
- S1** Universal Symbols: AIGA/TXDOT style symbol artwork
- S3** Veh. Arrow(s): use only official MUTCD/TXDOT arrow art

- VINYL (FILM) / DIGITAL PRINT:
- V7** White: 3M 4090 DG3 White (Reflective)
 - V9** Blue: 3M 4095 DG3 Blue (Reflective)

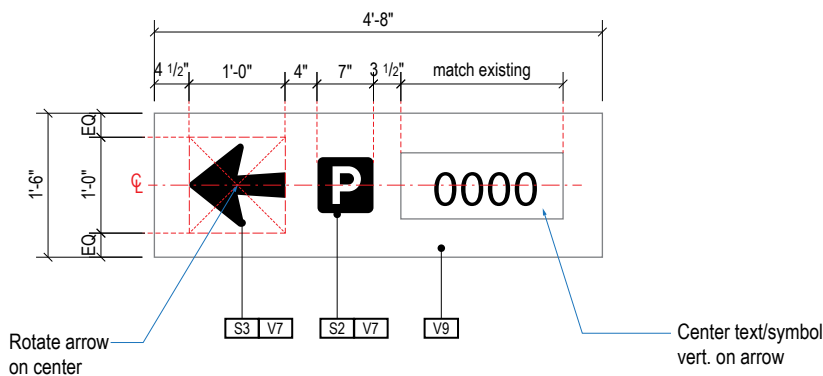

A FACE LAYOUT
Scale: 1/2" = 1'-0"

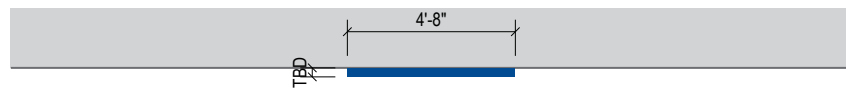

1 PLAN VIEW
Scale: 3/16" = 1'-0"

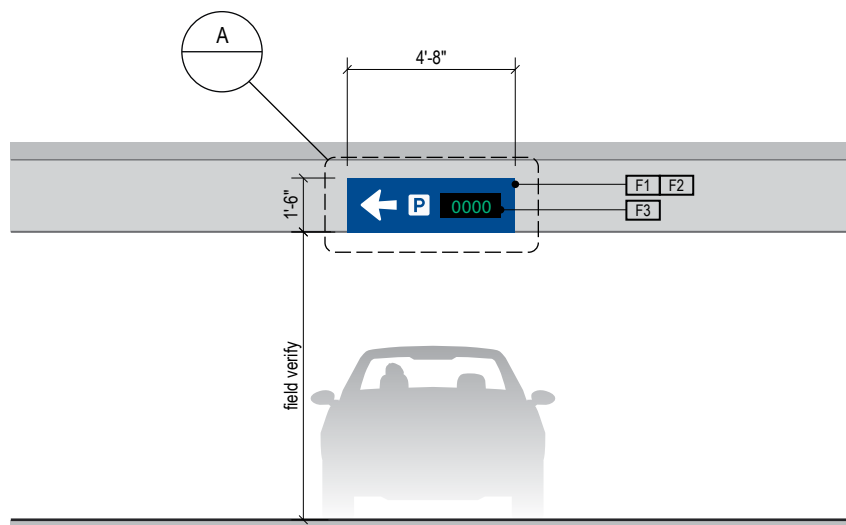

2 ELEVATION
Scale: 3/16" = 1'-0"

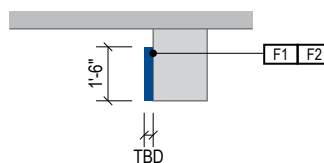

3 END VIEW
Scale: 3/16" = 1'-0"

WARNING:

This record contains Sensitive Security Information that is controlled under 49 CFR parts 15 and 1520. No part of this record may be disclosed to persons with a "need to know," as defined in 49 CFR parts 15 and 1520, except with the written permission of the Administrator of the Transportation Security Administration or the Secretary of Transportation. Unauthorized release may result in civil penalty or other action. For U.S. government agencies, public disclosure is governed by 5 U.S.C. 552 and 49 CFR parts 15 and 1520.

ILLUMINATION	SIGN TYPE	SIGN FUNCTION	MOUNTING METHOD	GENERAL DESCRIPTION & USE
REFLECTIVE / DYNAMIC LED	5-DR.17	DIRECTIONAL	BEAM/WALL	VEHICULAR - Directionals w/ 2 Message per Direction; 2 directions; 1 side

GENERAL NOTES

- All final design, engineering, and amount/sizing of structural sign support elements, material types/thicknesses, dimensions, and attachment methods shall be performed and approved by a licensed engineer to meet or exceed all applicable local and national codes.
- Final engineering, dimensions, materials, and fabrication are the responsibility of the Fabricator to ensure the highest quality fit and finish for all components of the completed product. All final detailing and specifications to be provided by the Fabricator within their final approved fabrication-ready shop drawings.
- Wherever dissimilar metals are in contact, always separate contact surfaces prior to assembly or installation with the necessary protective coatings/gaskets/washers to prevent galvanic corrosion.
- Final fabrication methods, quality and fit/finish to be reviewed and approved by DFW Planning Department and wayfinding/architecture Design Consultants thru prototype reviews prior to final production run/installation processes (see Performance Specifications for details).
- Colors shown are for reference only, and are subject to the limitations of the printing process and/or variance of electronic RGB screen displays. Refer to color system swatches and/or final finish samples for accurate reference.
- Messages shown here are general placeholders only. See graphic message schedules for specific messaging by location and sign type.

FABRICATION INTENT NOTES

- F1** SIGN BOX: fabricated aluminum extrusion frame with removable aluminum face panels, all welds filled and ground smooth for seamless appearance; removable faces use internal hidden top aluminum panel clip and are mechanically fastened with countersunk S.S. screws at bottom returns edges of extrusion frame (paint screwheads to match returns) into internal aluminum angle; vertical support tubes mechanically fastened to top of sign box extrusion frame; digitally printed full-bleed color graphics on 3M Reflective DG3 4090 White film applied to 1st surface of face panels; all exposed surfaces, returns, etc to be painted with MAP paint to match P1, satin finish; routed cut-outs in face panels and vents in sign box sized per dynamic unit required
- F2** MOUNTING: mechanically fasten sign panels to wall/beam/soffit with stainless steel tamper-proof mechanical fasteners as install conditions require (Fabricator to field verify), paint heads to match sign face; NOTE: Fabricator to use proper connection gaskets/seals/etc to eliminate corrosion from mounting surface and weather conditions as install location conditions require (Fabricator to field verify)
- F3** DYNAMIC SPACE COUNT UNIT: By others

GRAPHICS / COLORS / DECORATION NOTES

- L1** Typeface: font = ClearviewText Medium
 - S1** Universal Symbols: AIGA/TXDOT style symbol artwork
 - S3** Veh. Arrow(s): use only official MUTCD/TXDOT arrow art
- VINYL (FILM) / DIGITAL PRINT:
- V7** White: 3M 4090 DG3 White (Reflective)
 - V9** Blue: 3M 4095 DG3 Blue (Reflective)

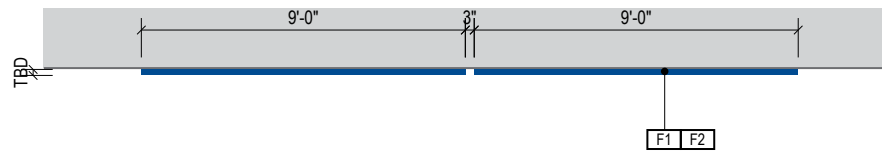

1 PLAN VIEW
Scale: 3/16" = 1'-0"

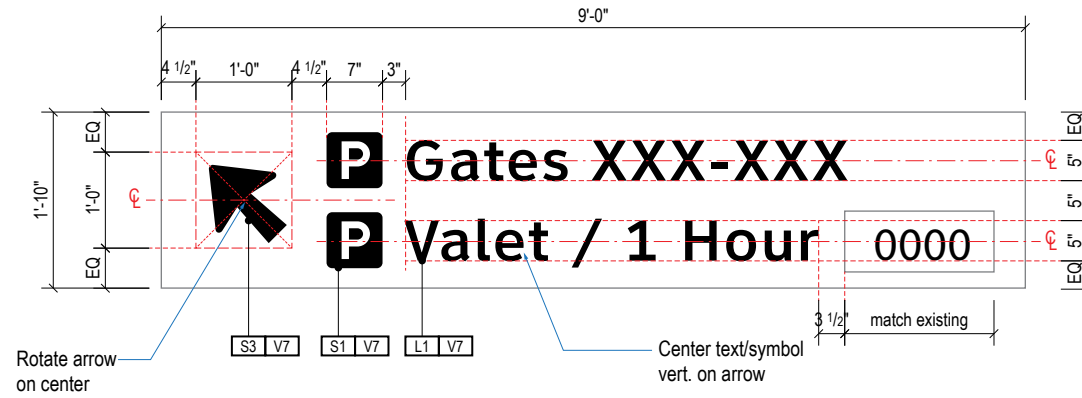

A FACE LAYOUT
Scale: 1/2" = 1'-0"

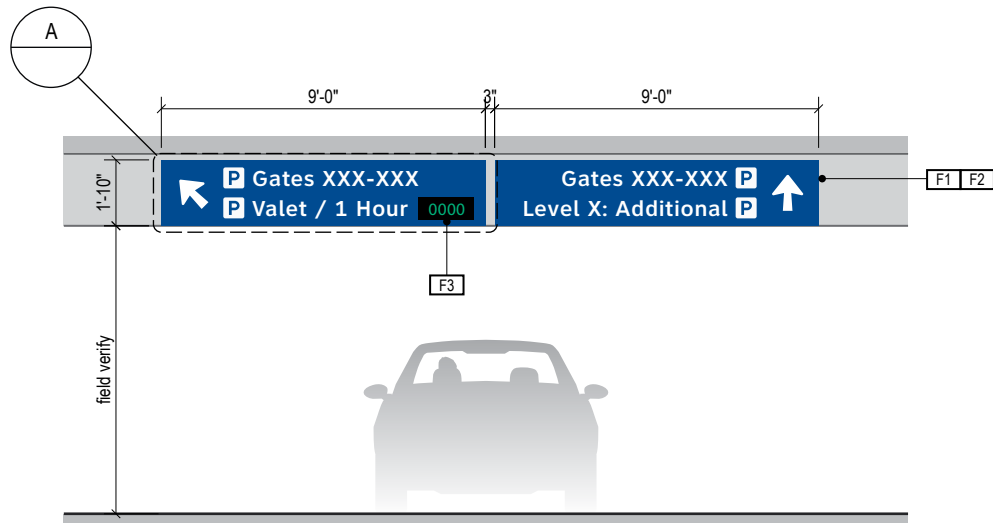

2 ELEVATION
Scale: 3/16" = 1'-0"

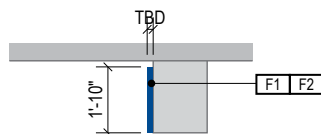

3 END VIEW
Scale: 3/16" = 1'-0"

ILLUMINATION	SIGN TYPE	SIGN FUNCTION	MOUNTING METHOD	GENERAL DESCRIPTION & USE
REFLECTIVE	5-DR.18	DIRECTIONAL	BEAM/WALL	VEHICULAR - Exit Trailblazer; 1 direction; 1 side

GENERAL NOTES

- All final design, engineering, and amount/sizing of structural sign support elements, material types/thicknesses, dimensions, and attachment methods shall be performed and approved by a licensed engineer to meet or exceed all applicable local and national codes.
- Final engineering, dimensions, materials, and fabrication are the responsibility of the Fabricator to ensure the highest quality fit and finish for all components of the completed product. All final detailing and specifications to be provided by the Fabricator within their final approved fabrication-ready shop drawings.
- Wherever dissimilar metals are in contact, always separate contact surfaces prior to assembly or installation with the necessary protective coatings/gaskets/washers to prevent galvanic corrosion.
- Final fabrication methods, quality and fit/finish to be reviewed and approved by DFW Planning Department and wayfinding/architecture Design Consultants thru prototype reviews prior to final production run/installation processes (see Performance Specifications for details).
- Colors shown are for reference only, and are subject to the limitations of the printing process and/or variance of electronic RGB screen displays. Refer to color system swatches and/or final finish samples for accurate reference.
- Messages shown here are general placeholders only. See graphic message schedules for specific messaging by location and sign type.

FABRICATION INTENT NOTES

- F1** SIGN FACE PANELS: 1/4" thick aluminum sign face panels; digitally printed full-bleed color graphics on 3M Reflective DG3 4090 White film applied to 1st surface of face panels; all exposed surfaces and returns to be painted with MAP paint to match P1, satin finish
- F2** MOUNTING: mechanically fasten sign panels to wall/beam/soffit with stainless steel tamper-proof mechanical fasteners as install conditions require (Fabricator to field verify), paint heads to match sign face; NOTE: Fabricator to use proper connection gaskets/seals/etc to eliminate corrosion from mounting surface and weather conditions as install location conditions require (Fabricator to field verify)

GRAPHICS / COLORS / DECORATION NOTES

- L2** Typeface: font = ClearviewText Bold
 - S1** Universal Symbols: AIGA/TXDOT style symbol artwork
 - S3** Veh. Arrow(s): use only official MUTCD/TXDOT arrow art
- VINYL (FILM) / DIGITAL PRINT:
- V4** Light Green: match PMS 368C
 - V7** White: 3M 4090 DG3 White (Reflective)
 - V9** Blue: 3M 4095 DG3 Blue (Reflective)

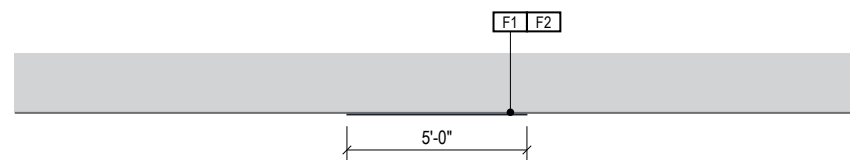

1 PLAN VIEW
Scale: 3/16" = 1'-0"

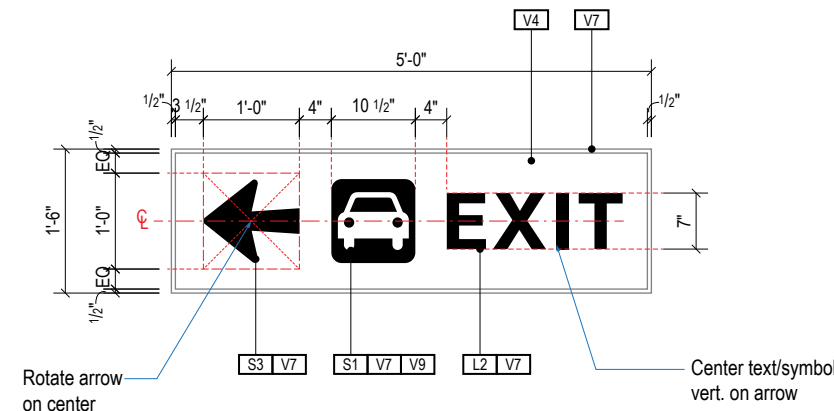

A FACE LAYOUT
Scale: 1/2" = 1'-0"

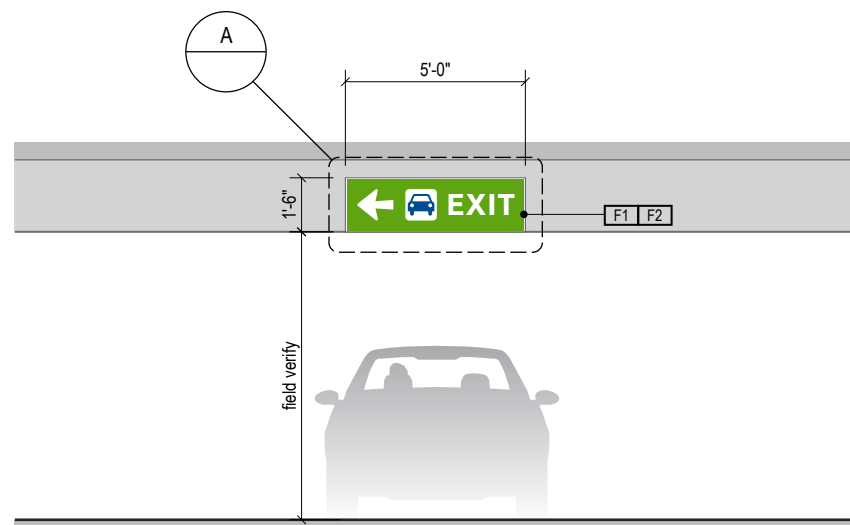

2 ELEVATION
Scale: 3/16" = 1'-0"

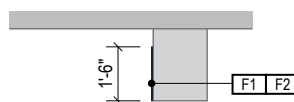

3 END VIEW
Scale: 3/16" = 1'-0"

ILLUMINATION	SIGN TYPE	SIGN FUNCTION	MOUNTING METHOD	GENERAL DESCRIPTION & USE
REFLECTIVE	5-DR.19	DIRECTIONAL	BEAM/WALL	VEHICULAR - Garage Ramp Entry Directional

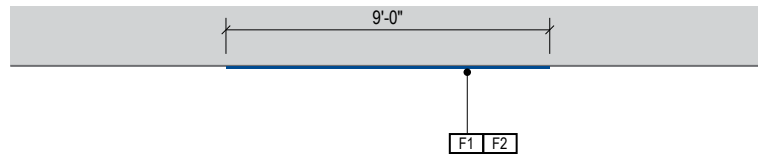

1 PLAN VIEW
Scale: 3/16" = 1'-0"

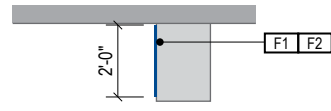

3 END VIEW
Scale: 3/16" = 1'-0"

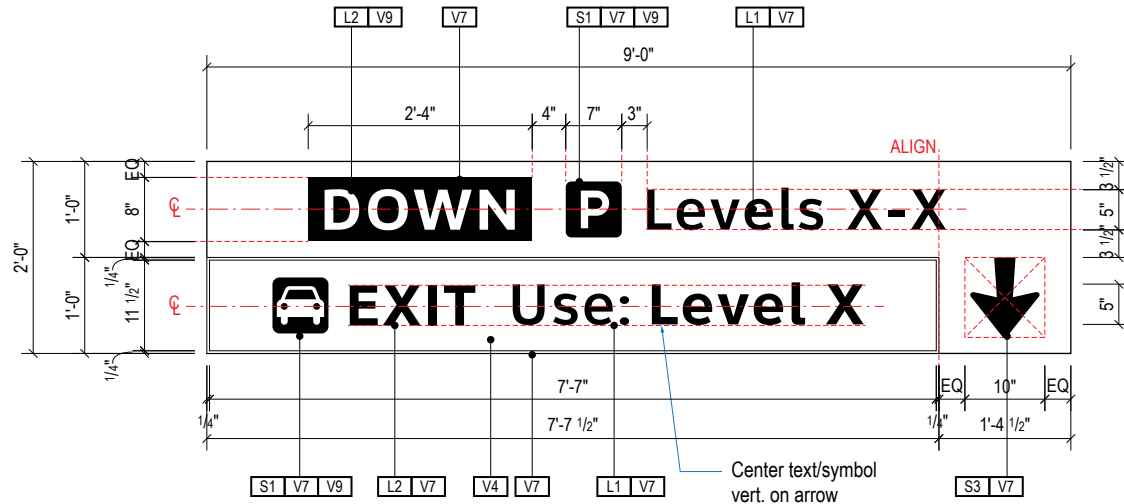

A FACE LAYOUT
Scale: 1/2" = 1'-0"

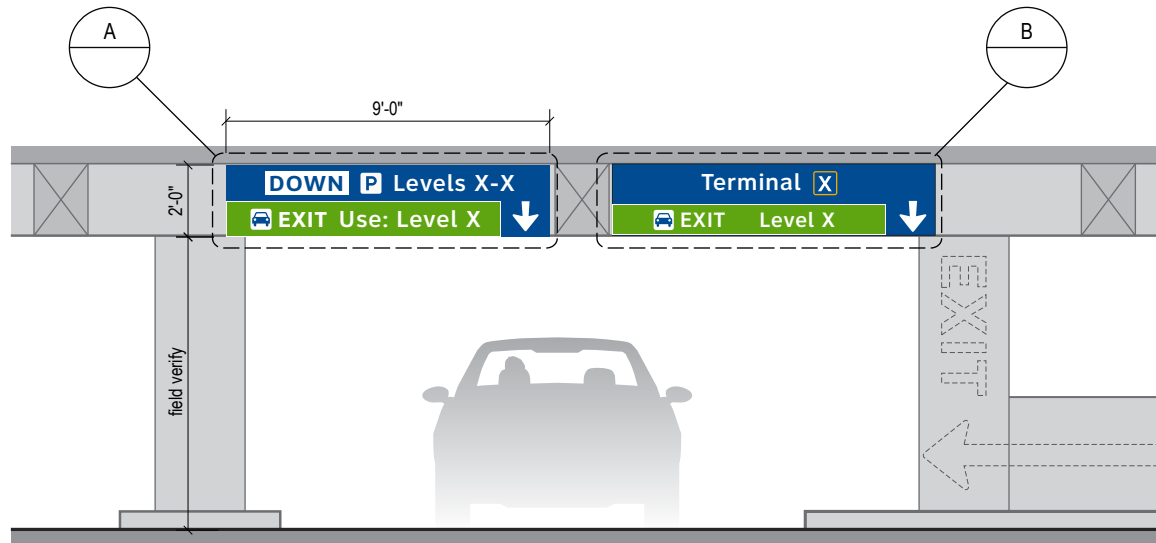

2 ELEVATION
Scale: 3/16" = 1'-0"

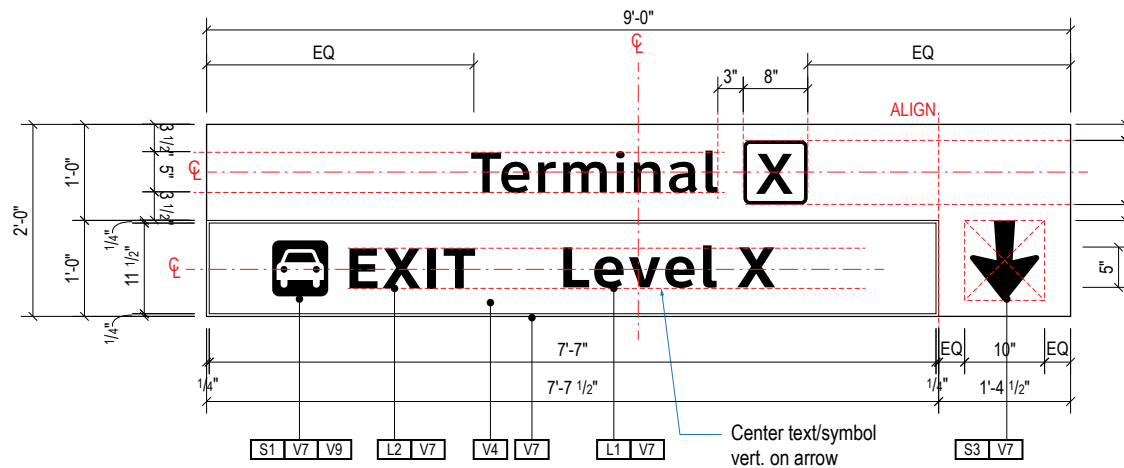

B ALTERNATIVE FACE LAYOUT
Scale: 1/2" = 1'-0"

GENERAL NOTES

- All final design, engineering, and amount/sizing of structural sign support elements, material types/thicknesses, dimensions, and attachment methods shall be performed and approved by a licensed engineer to meet or exceed all applicable local and national codes.
- Final engineering, dimensions, materials, and fabrication are the responsibility of the Fabricator to ensure the highest quality fit and finish for all components of the completed product. All final detailing and specifications to be provided by the Fabricator within their final approved fabrication-ready shop drawings.
- Wherever dissimilar metals are in contact, always separate contact surfaces prior to assembly or installation with the necessary protective coatings/gaskets/washers to prevent galvanic corrosion.
- Final fabrication methods, quality and finish to be reviewed and approved by DFW Planning Department and wayfinding/architecture Design Consultants thru prototype reviews prior to final production run/installation processes (see Performance Specifications for details).
- Colors shown are for reference only, and are subject to the limitations of the printing process and/or variance of electronic RGB screen displays. Refer to color system swatches and/or final finish samples for accurate reference.
- Messages shown here are general placeholders only. See graphic message schedules for specific messaging by location and sign type.

FABRICATION INTENT NOTES

- F1** SIGN FACE PANELS: 1/4" thick aluminum sign face panels; digitally printed full-bleed color graphics on 3M Reflective DG3 4090 White film applied to 1st surface of face panels; all exposed surfaces and returns to be painted with MAP paint to match P1, satin finish
- F2** MOUNTING: mechanically fasten sign panels to wall/beam/soffit with stainless steel tamper-proof mechanical fasteners as install conditions require (Fabricator to field verify), paint heads to match sign face; NOTE: Fabricator to use proper connection gaskets/seals/etc to eliminate corrosion from mounting surface and weather conditions as install location conditions require (Fabricator to field verify)

GRAPHICS / COLORS / DECORATION NOTES

- L1** Typeface: font = ClearviewText Medium
 - S1** Universal Symbols: use only official DFW symbol artwork
 - S2** Arrow(s): use only official DFW wayfinding arrow artwork
- VINYL (FILM) / DIGITAL PRINT:
- V7** White: 3M 4090 DG3 White (Reflective)
 - V8** Yellow: 3M 4091 DG3 Yellow (Reflective)
 - V9** Blue: 3M 4095 DG3 Blue (Reflective)

WARNING:

This record contains Sensitive Security Information that is controlled under 49 CFR parts 15 and 1520. No part of this record may be disclosed to persons with a "need to know," as defined in 49 CFR parts 15 and 1520, except with the written permission of the Administrator of the Transportation Security Administration or the Secretary of Transportation. Unauthorized release may result in civil penalty or other action. For U.S. government agencies, public disclosure is governed by 5 U.S.C. 552 and 49 CFR parts 15 and 1520.

ILLUMINATION	SIGN TYPE	SIGN FUNCTION	MOUNTING METHOD	GENERAL DESCRIPTION & USE
REFLECTIVE	5-DR.21	DIRECTIONAL	BEAM/WALL	PEDESTRIAN - Beam/Wall Mount Terminal Trailblazer

GENERAL NOTES

- All final design, engineering, and amount/sizing of structural sign support elements, material types/thicknesses, dimensions, and attachment methods shall be performed and approved by a licensed engineer to meet or exceed all applicable local and national codes.
- Final engineering, dimensions, materials, and fabrication are the responsibility of the Fabricator to ensure the highest quality fit and finish for all components of the completed product. All final detailing and specifications to be provided by the Fabricator within their final approved fabrication-ready shop drawings.
- Wherever dissimilar metals are in contact, always separate contact surfaces prior to assembly or installation with the necessary protective coatings/gaskets/washers to prevent galvanic corrosion.
- Final fabrication methods, quality and fit/finish to be reviewed and approved by DFW Planning Department and wayfinding/architecture Design Consultants thru prototype reviews prior to final production run/installation processes (see Performance Specifications for details).
- Colors shown are for reference only, and are subject to the limitations of the printing process and/or variance of electronic RGB screen displays. Refer to color system swatches and/or final finish samples for accurate reference.
- Messages shown here are general placeholders only. See graphic message schedules for specific messaging by location and sign type.

FABRICATION INTENT NOTES

- F1** SIGN FACE PANELS: 1/4" thick aluminum sign face panels; digitally printed full-bleed color graphics on 3M Reflective DG3 4090 White film applied to 1st surface of face panels; all exposed surfaces and returns to be painted with MAP paint to match P1, satin finish
- F2** MOUNTING: mechanically fasten sign panels to wall/beam/soffit with stainless steel tamper-proof mechanical fasteners as install conditions require (Fabricator to field verify), paint heads to match sign face; NOTE: Fabricator to use proper connection gaskets/seals/etc to eliminate corrosion from mounting surface and weather conditions as install location conditions require (Fabricator to field verify)

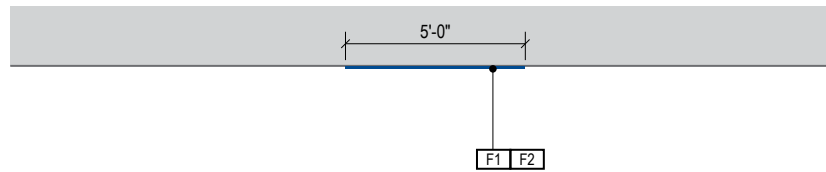

1 PLAN VIEW
Scale: 3/16" = 1'-0"

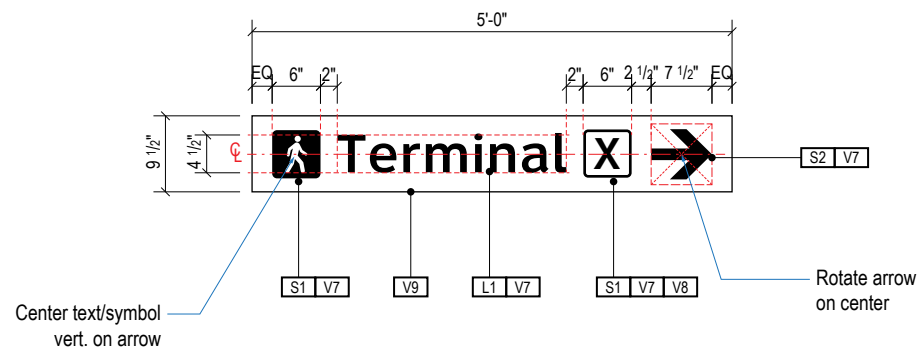

A FACE LAYOUT
Scale: 1/2" = 1'-0"

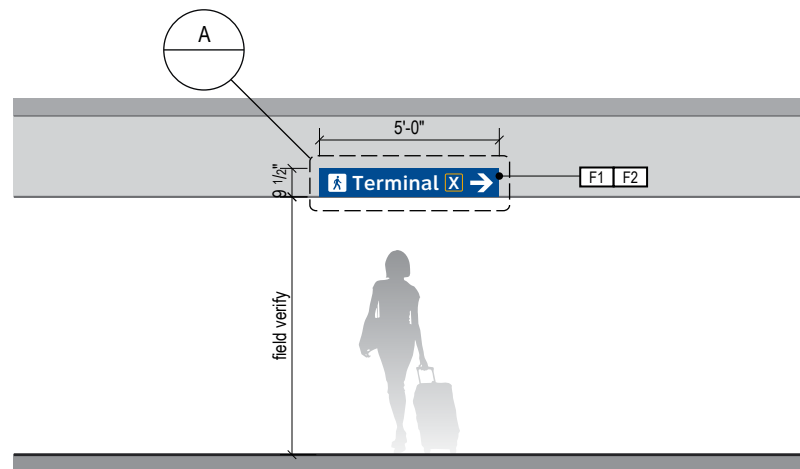

2 ELEVATION
Scale: 3/16" = 1'-0"

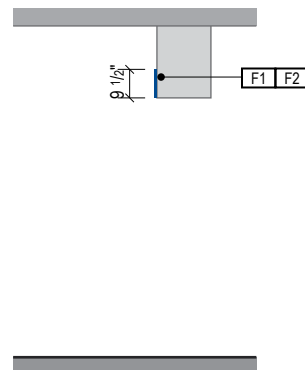

3 END VIEW
Scale: 3/16" = 1'-0"

GRAPHICS / COLORS / DECORATION NOTES

- L1** Typeface: font = ClearviewText Medium
- S1** Universal Symbols: use only official DFW symbol artwork
- S2** Arrow(s): use only official DFW wayfinding arrow artwork

VINYL (FILM) / DIGITAL PRINT:

- V7** White: 3M 4090 DG3 White (Reflective)
- V8** Yellow: 3M 4091 DG3 Yellow (Reflective)
- V9** Blue: 3M 4095 DG3 Blue (Reflective)

WARNING:

This record contains Sensitive Security Information that is controlled under 49 CFR parts 15 and 1520. No part of this record may be disclosed to persons with a "need to know," as defined in 49 CFR parts 15 and 1520, except with the written permission of the Administrator of the Transportation Security Administration or the Secretary of Transportation. Unauthorized release may result in civil penalty or other action. For U.S. government agencies, public disclosure is governed by 5 U.S.C. 552 and 49 CFR parts 15 and 1520.

ILLUMINATION	SIGN TYPE	SIGN FUNCTION	MOUNTING METHOD	GENERAL DESCRIPTION & USE
INTERNAL	5-DR.25	DIRECTIONAL	BEAM/WALL	PEDESTRIAN - Garage Section Directional (exterior pedestrian entrances)

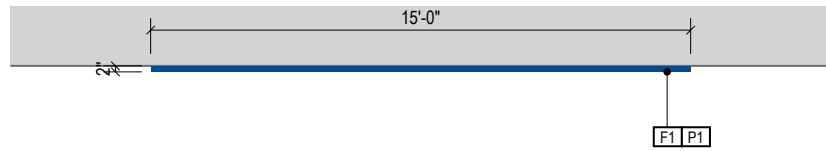

1 PLAN VIEW
Scale: 3/16" = 1'-0"

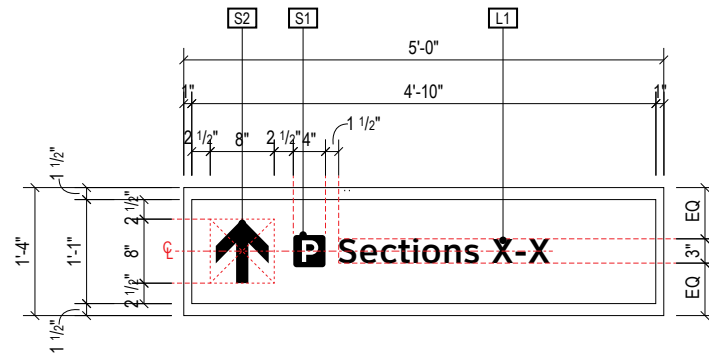

A FACE LAYOUT
Scale: 1/2" = 1'-0"

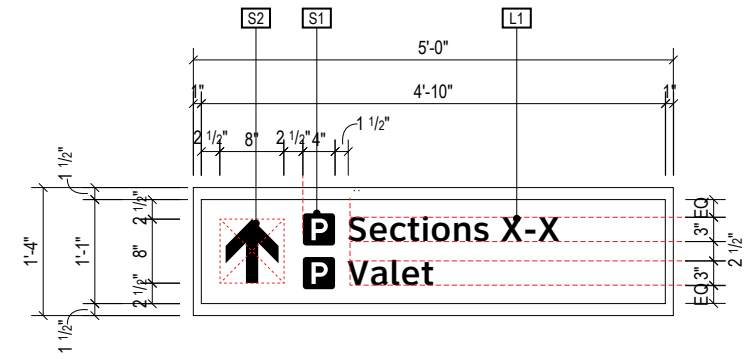

B FACE LAYOUT
Scale: 1/2" = 1'-0"

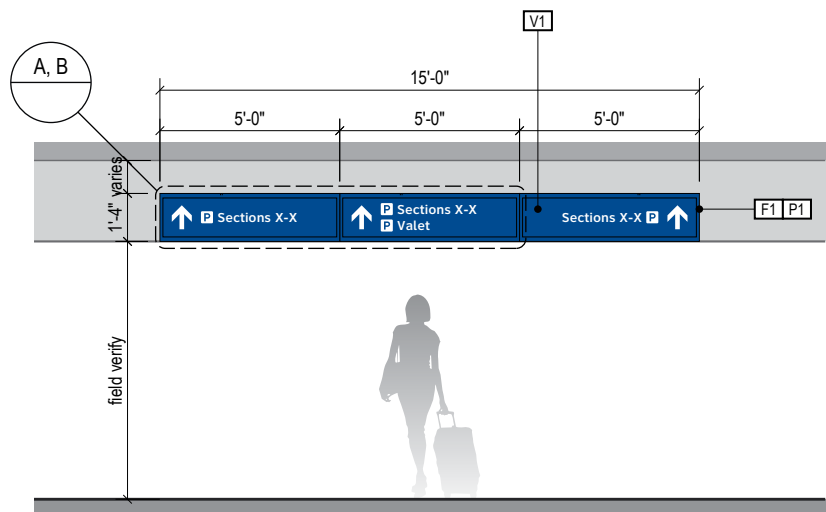

2 ELEVATION
Scale: 3/16" = 1'-0"

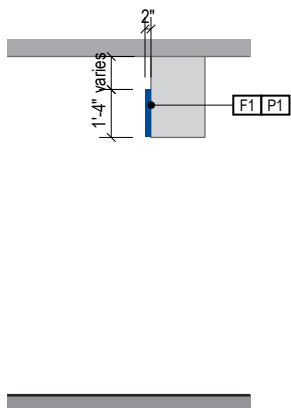

3 END VIEW
Scale: 3/16" = 1'-0"

GENERAL NOTES

- All final design, engineering, and amount/sizing of structural sign support elements, material types/thicknesses, dimensions, and attachment methods shall be performed and approved by a licensed engineer to meet or exceed all applicable local and national codes.
- Final engineering, dimensions, materials, and fabrication are the responsibility of the Fabricator to ensure the highest quality fit and finish for all components of the completed product. All final detailing and specifications to be provided by the Fabricator within their final approved fabrication-ready shop drawings.
- Wherever dissimilar metals are in contact, always separate contact surfaces prior to assembly or installation with the necessary protective coatings/gaskets/washers to prevent galvanic corrosion.
- Final fabrication methods, quality and fit/finish to be reviewed and approved by DFW Planning Department and wayfinding/architecture Design Consultants thru prototype reviews prior to final production run/installation processes (see Performance Specifications for details).
- Colors shown are for reference only, and are subject to the limitations of the printing process and/or variance of electronic RGB screen displays. Refer to color system swatches and/or final finish samples for accurate reference.
- Messages shown here are general placeholders only. See graphic message schedules for specific messaging by location and sign type.

FABRICATION INTENT NOTES

- F1** CABINETS:
- SIGN CABINET: two-piece extruded aluminum frame; cabinet has internal hinges at bottom to allow removal of face frame for access to copy panel and LED light module; powdercoat all exposed surfaces to match P1, satin finish
 - FACE FRAME: hinged at bottom and secured with FHMS at top; translucent white, 3/16" thick acrylic copy panel with first surface applied vinyl; V1 is secured to face frame with .090" thick aluminum retainers inside frame; frame slides forward on hinges and pivots 15 degree max. to remove
 - BACK FRAME: hinged at bottom to receive face frame; contains LED light module; 1/8" thick aluminum sheet back panel is welded to extruded frame; receives mounting bracket and "Z" clips for mounting to angled mounting bracket
- F2** MOUNTING: mount to wall structural elements with connection system as installation location conditions require; provide seal at all exterior wall penetrations (Fabricator to coordinate connection location/type of structural elements with General Contractor)

GRAPHICS / COLORS / DECORATION NOTES

- L1** Typeface: font = ClearviewText Medium
 - S1** Universal Symbols: use only official DFW symbol artwork
 - S2** Arrow(s): use only official DFW wayfinding arrow artwork
- VINYL (FILM) / DIGITAL PRINT:
- V1** Blue: 3M EC 7725-37 Sapphire Blue
- PAINT:
- P1** Blue: Powder coated polyester TGIC #PLSF21528PT

WARNING:

This record contains Sensitive Security Information that is controlled under 49 CFR parts 15 and 1520. No part of this record may be disclosed to persons with a "need to know," as defined in 49 CFR parts 15 and 1520, except with the written permission of the Administrator of the Transportation Security Administration or the Secretary of Transportation. Unauthorized release may result in civil penalty or other action. For U.S. government agencies, public disclosure is governed by 5 U.S.C. 552 and 49 CFR parts 15 and 1520.

ILLUMINATION	SIGN TYPE	SIGN FUNCTION	MOUNTING METHOD	GENERAL DESCRIPTION & USE
INTERNAL	5-DR.26	DIRECTIONAL	BEAM/WALL	PEDESTRIAN - Garage Section Directional w/ "Welcome" ID (interior areas near elevator cores)

GENERAL NOTES

- All final design, engineering, and amount/sizing of structural sign support elements, material types/thicknesses, dimensions, and attachment methods shall be performed and approved by a licensed engineer to meet or exceed all applicable local and national codes.
- Final engineering, dimensions, materials, and fabrication are the responsibility of the Fabricator to ensure the highest quality fit and finish for all components of the completed product. All final detailing and specifications to be provided by the Fabricator within their final approved fabrication-ready shop drawings.
- Wherever dissimilar metals are in contact, always separate contact surfaces prior to assembly or installation with the necessary protective coatings/gaskets/washers to prevent galvanic corrosion.
- Final fabrication methods, quality and fit/finish to be reviewed and approved by DFW Planning Department and wayfinding/architecture Design Consultants thru prototype reviews prior to final production run/installation processes (see Performance Specifications for details).
- Colors shown are for reference only, and are subject to the limitations of the printing process and/or variance of electronic RGB screen displays. Refer to color system swatches and/or final finish samples for accurate reference.
- Messages shown here are general placeholders only. See graphic message schedules for specific messaging by location and sign type.

FABRICATION INTENT NOTES

- F1** CABINETS:
- SIGN CABINET: two-piece extruded aluminum frame; cabinet has internal hinges at bottom to allow removal of face frame for access to copy panel and LED light module; powdercoat all exposed surfaces to match P1, satin finish
 - FACE FRAME: hinged at bottom and secured with FHMS at top; translucent white, 3/16" thick acrylic copy panel with first surface applied vinyl; V1 is secured to face frame with .090" thick aluminum retainers inside frame; frame slides forward on hinges and pivots 15 degree max. to remove
 - BACK FRAME: hinged at bottom to receive face frame; contains LED light module; 1/8" thick aluminum sheet back panel is welded to extruded frame; receives mounting bracket and "Z" clips for mounting to angled mounting bracket
- F2** MOUNTING: mount to wall structural elements with connection system as installation location conditions require; provide seal at all exterior wall penetrations (Fabricator to coordinate connection location/type of structural elements with General Contractor)

GRAPHICS / COLORS / DECORATION NOTES

- L1** Typeface: font = ClearviewText Medium
 - S1** Universal Symbols: use only official DFW symbol artwork
 - S2** Arrow(s): use only official DFW wayfinding arrow artwork
- VINYL (FILM) / DIGITAL PRINT:
- V1** Blue: 3M EC 7725-37 Sapphire Blue
 - V3** Yellow: 3M 3630-25 Sunflower
- PAINT:
- P1** Blue: Powder coated polyester TGIC #PLSF21528PT

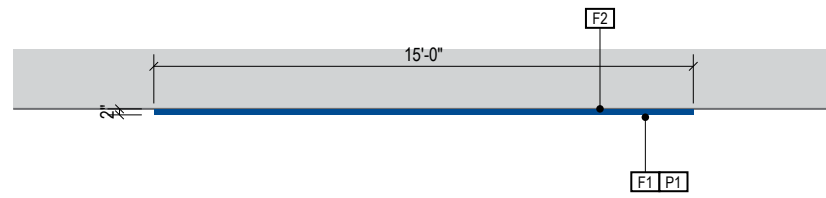

1 PLAN VIEW
Scale: 3/16" = 1'-0"

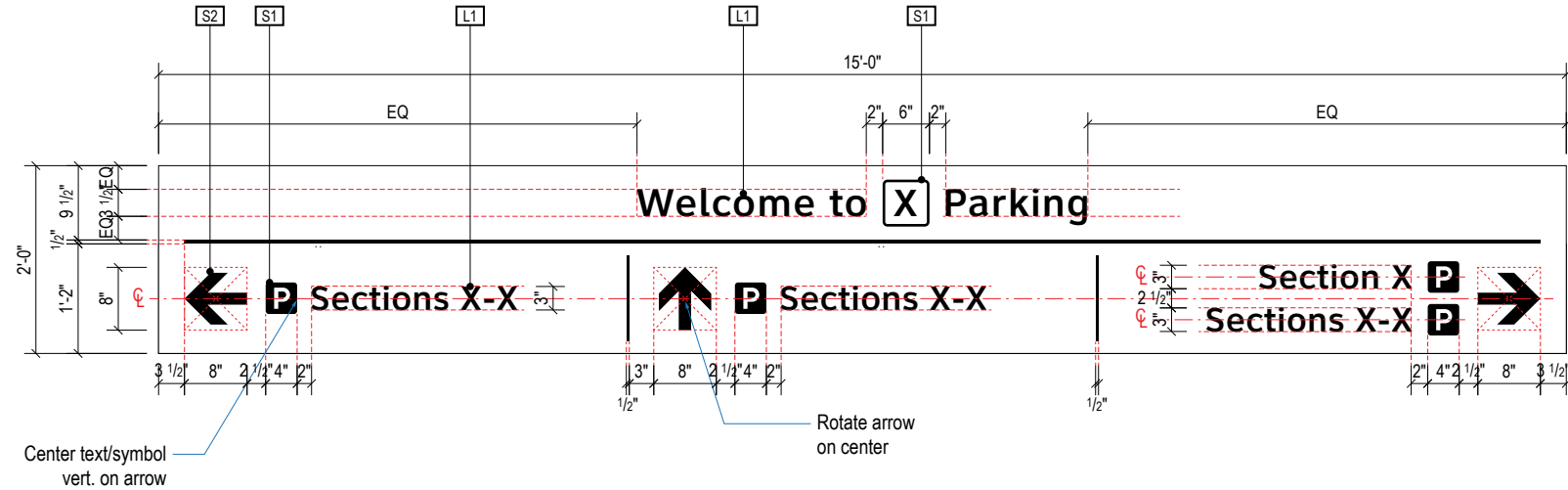

A FACE LAYOUT
Scale: 1/2" = 1'-0"

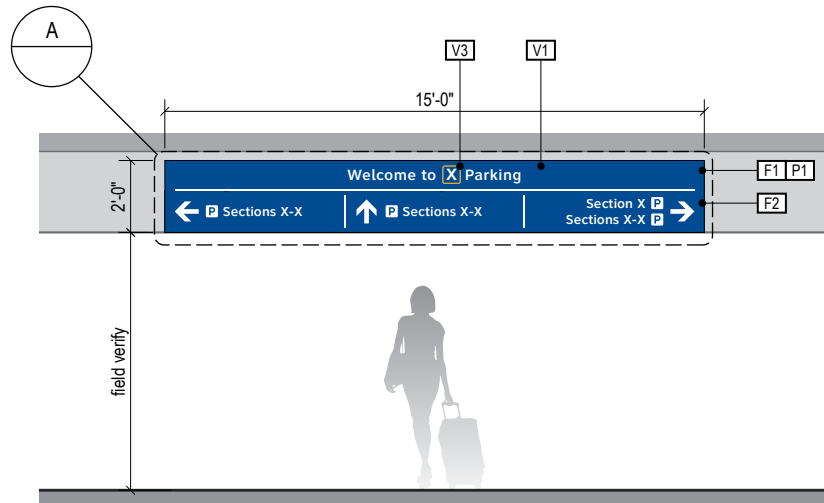

2 ELEVATION
Scale: 3/16" = 1'-0"

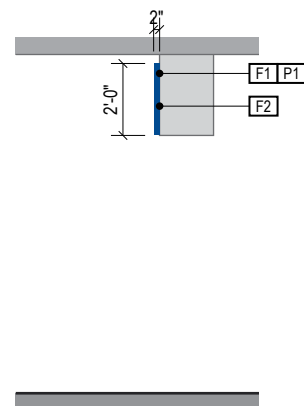

3 END VIEW
Scale: 3/16" = 1'-0"

ILLUMINATION	SIGN TYPE	SIGN FUNCTION	MOUNTING METHOD	GENERAL DESCRIPTION & USE
REFLECTIVE	5-DR.31	DIRECTIONAL	SUSPENDED	PEDESTRIAN - Terminal Trailblazer

GENERAL NOTES

- All final design, engineering, and amount/sizing of structural sign support elements, material types/thicknesses, dimensions, and attachment methods shall be performed and approved by a licensed engineer to meet or exceed all applicable local and national codes.
- Final engineering, dimensions, materials, and fabrication are the responsibility of the Fabricator to ensure the highest quality fit and finish for all components of the completed product. All final detailing and specifications to be provided by the Fabricator within their final approved fabrication-ready shop drawings.
- Wherever dissimilar metals are in contact, always separate contact surfaces prior to assembly or installation with the necessary protective coatings/gaskets/washers to prevent galvanic corrosion.
- Final fabrication methods, quality and fit/finish to be reviewed and approved by DFW Planning Department and wayfinding/architecture Design Consultants thru prototype reviews prior to final production run/installation processes (see Performance Specifications for details).
- Colors shown are for reference only, and are subject to the limitations of the printing process and/or variance of electronic RGB screen displays. Refer to color system swatches and/or final finish samples for accurate reference.
- Messages shown here are general placeholders only. See graphic message schedules for specific messaging by location and sign type.

FABRICATION INTENT NOTES

- F1** SIGN FACE PANELS: 1/8" thick aluminum sign face panels; mechanically fasten sign panels to support tube structure with stainless steel countersunk screws, paint heads to match sign face; digitally printed full-bleed color graphics on 3M Reflective DG3 4090 White film applied to 1st surface of face panels; all exposed surfaces, returns, etc. to be clearcoated to prevent corrosion
- F2** SUPPORT FRAME/SUSPENSION: fabricated 2" square aluminum support tube frame and vertical suspension tube structure; all exposed support frame tube ends to be capped with aluminum; all welds on frame/caps to be filled and ground smooth for uniform appearance; suspension tubes mechanically attached to ceiling attachment hinge plates above; ceiling attachment plates to be mechanically fastened to garage's structural ceiling elements as required with mech. fasteners (fabricator to field verify); support frame, suspension tubes and hinge plates to be painted all exposed surfaces with MAP paint to match P2, satin finish

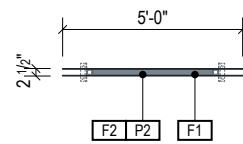

1 PLAN VIEW
Scale: 3/16" = 1'-0"

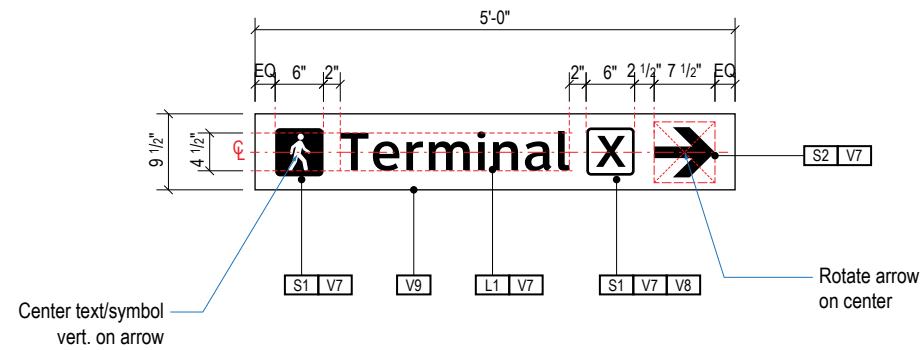

A FACE LAYOUT
Scale: 1/2" = 1'-0"

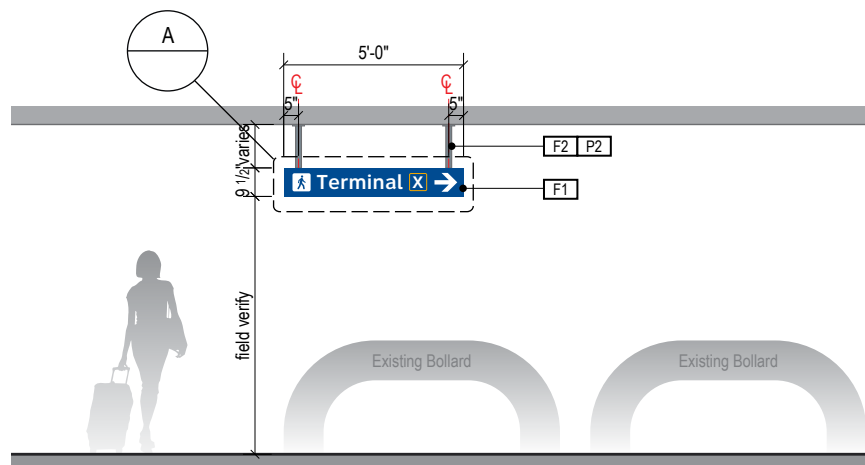

2 ELEVATION
Scale: 3/16" = 1'-0"

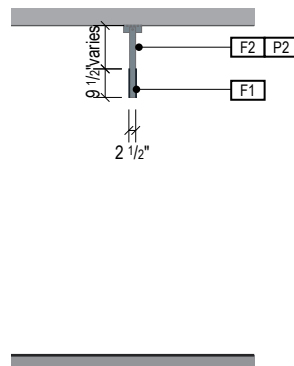

3 END VIEW
Scale: 3/16" = 1'-0"

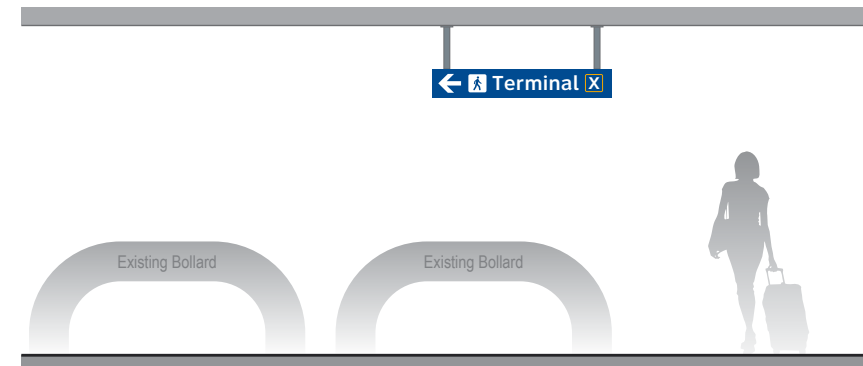

4 ELEVATION (OPPOSITE SIDE)
Scale: 3/16" = 1'-0"

GRAPHICS / COLORS / DECORATION NOTES

- L1** Typeface: font = ClearviewText Medium
 - S1** Universal Symbols: use only official DFW symbol artwork
 - S2** Arrow(s): use only official DFW wayfinding arrow artwork
- VINYL (FILM) / DIGITAL PRINT:
- V7** White: 3M 4090 DG3 White (Reflective)
 - V8** Yellow: 3M 4091 DG3 Yellow (Reflective)
 - V9** Blue: 3M 4095 DG3 Blue (Reflective)

WARNING:

This record contains Sensitive Security Information that is controlled under 49 CFR parts 15 and 1520. No part of this record may be disclosed to persons with a "need to know," as defined in 49 CFR parts 15 and 1520, except with the written permission of the Administrator of the Transportation Security Administration or the Secretary of Transportation. Unauthorized release may result in civil penalty or other action. For U.S. government agencies, public disclosure is governed by 5 U.S.C. 552 and 49 CFR parts 15 and 1520.

ILLUMINATION	SIGN TYPE	SIGN FUNCTION	MOUNTING METHOD	GENERAL DESCRIPTION & USE
REFLECTIVE	5-DR.41	DIRECTIONAL	POST MOUNT	PEDESTRIAN - Terminal Trailblazer

GENERAL NOTES

- All final design, engineering, and amount/sizing of structural sign support elements, material types/thicknesses, dimensions, and attachment methods shall be performed and approved by a licensed engineer to meet or exceed all applicable local and national codes.
- Final engineering, dimensions, materials, and fabrication are the responsibility of the Fabricator to ensure the highest quality fit and finish for all components of the completed product. All final detailing and specifications to be provided by the Fabricator within their final approved fabrication-ready shop drawings.
- Wherever dissimilar metals are in contact, always separate contact surfaces prior to assembly or installation with the necessary protective coatings/gaskets/washers to prevent galvanic corrosion.
- Final fabrication methods, quality and fit/finish to be reviewed and approved by DFW Planning Department and wayfinding/architecture Design Consultants thru prototype reviews prior to final production run/installation processes (see Performance Specifications for details).
- Colors shown are for reference only, and are subject to the limitations of the printing process and/or variance of electronic RGB screen displays. Refer to color system swatches and/or final finish samples for accurate reference.
- Messages shown here are general placeholders only. See graphic message schedules for specific messaging by location and sign type.

FABRICATION INTENT NOTES

- [F1]** SIGN FACE PANELS: 1/4" thick aluminum sign face panels; mechanically fasten sign panels to support tube structure with stainless steel tamper-proof screws, paint heads to match sign face; digitally printed full-bleed color graphics on 3M Reflective DG3 4090 White film applied to 1st surface of face panels; all exposed surfaces, returns, etc. to be painted with MAP paint to match P1, satin finish
- [F2]** SUPPORT FRAME/POST ATTACHMENT: fabricated 1" square aluminum support tube frame structure; all exposed support frame tube ends to be capped with aluminum; all welds on frame/caps to be filled and ground smooth for uniform appearance; support frame mechanically attached to light post attachment band; attachment band to be mechanically fastened to light post as required w/ mech. fasteners (fabricator to field verify); support frame and attachment bands to be painted all exposed surfaces with MAP paint to match P2, satin finish
- [F3]** LIGHT POST: existing light post at existing garage roof areas; fabricator to field verify light post conditions and engineer sign attachment to light posts as install locations require (NOTE: light post shown is artist rendering only and may not be representative of final light post product).

GRAPHICS / COLORS / DECORATION NOTES

- [L1]** Typeface: font = ClearviewText Medium
 - [S1]** Universal Symbols: use only official DFW symbol artwork
 - [S2]** Arrow(s): use only official DFW wayfinding arrow artwork
- VINYL (FILM) / DIGITAL PRINT:
- [V7]** White: 3M 4090 DG3 White (Reflective)
 - [V8]** Yellow: 3M 4091 DG3 Yellow (Reflective)
 - [V9]** Blue: 3M 4095 DG3 Blue (Reflective)

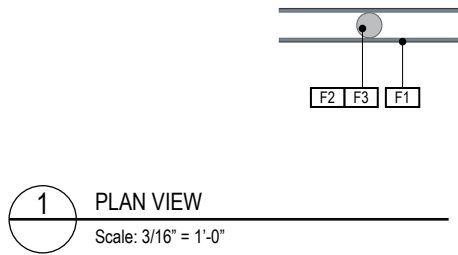

1 PLAN VIEW
Scale: 3/16" = 1'-0"

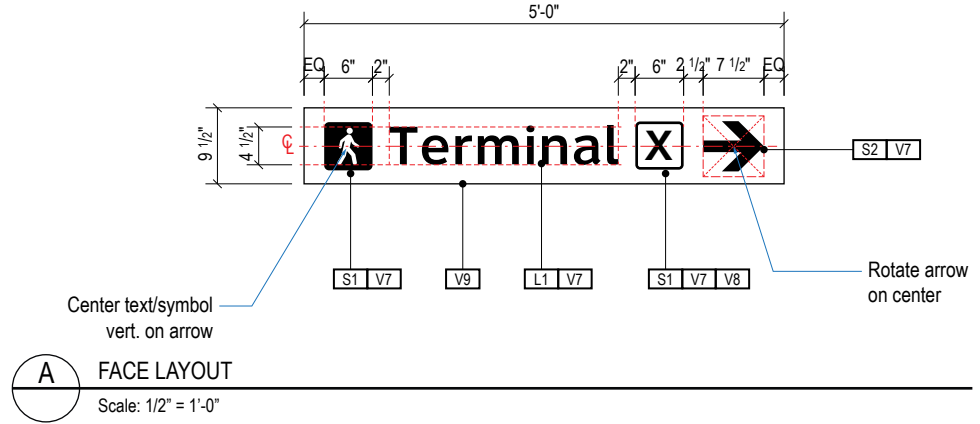

A FACE LAYOUT
Scale: 1/2" = 1'-0"

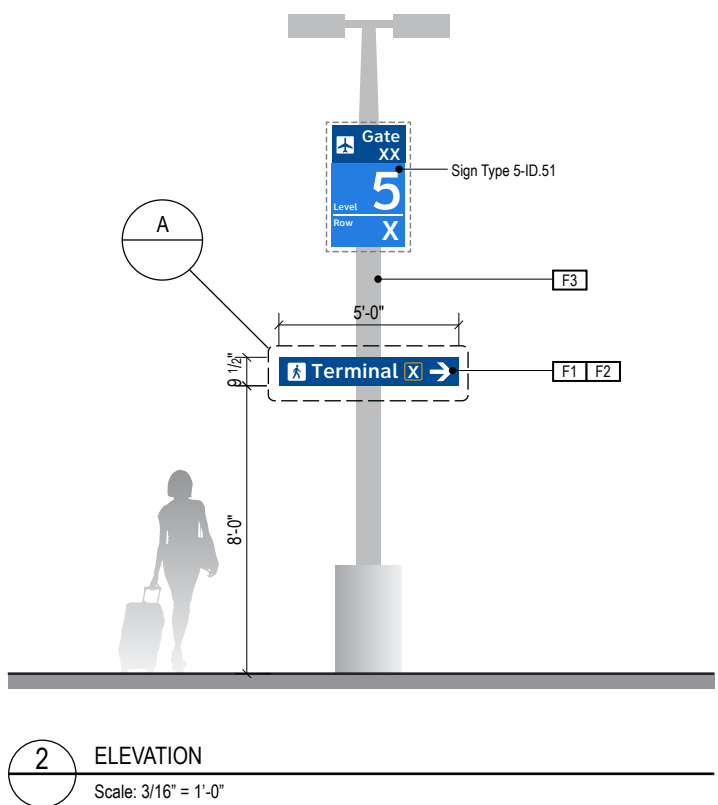

2 ELEVATION
Scale: 3/16" = 1'-0"

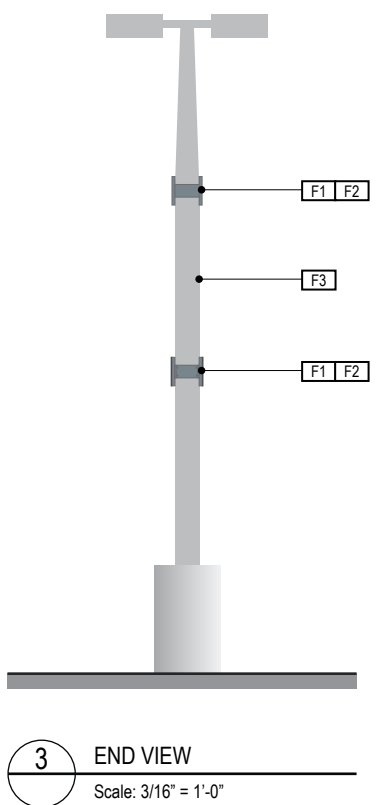

3 END VIEW
Scale: 3/16" = 1'-0"



4 ELEVATION
Scale: 3/16" = 1'-0"

ILLUMINATION	SIGN TYPE	SIGN FUNCTION	MOUNTING METHOD	GENERAL DESCRIPTION & USE
REFLECTIVE	5-DR.53	DIRECTIONAL	POST MOUNT	VEHICULAR - Roadside/Roof Level Exit Trailblazer

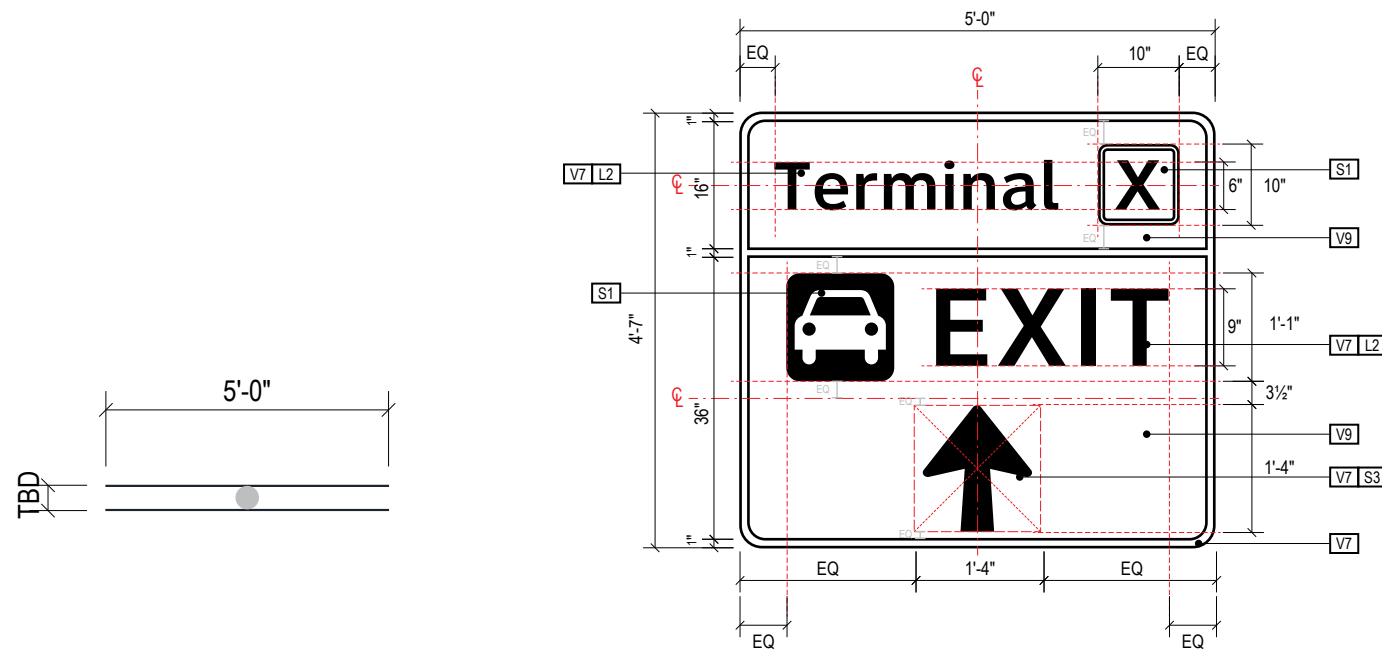

1 PLAN VIEW
Scale: 3/16" = 1'-0"

A FACE LAYOUT (outside garage)
Scale: 1/2" = 1'-0"

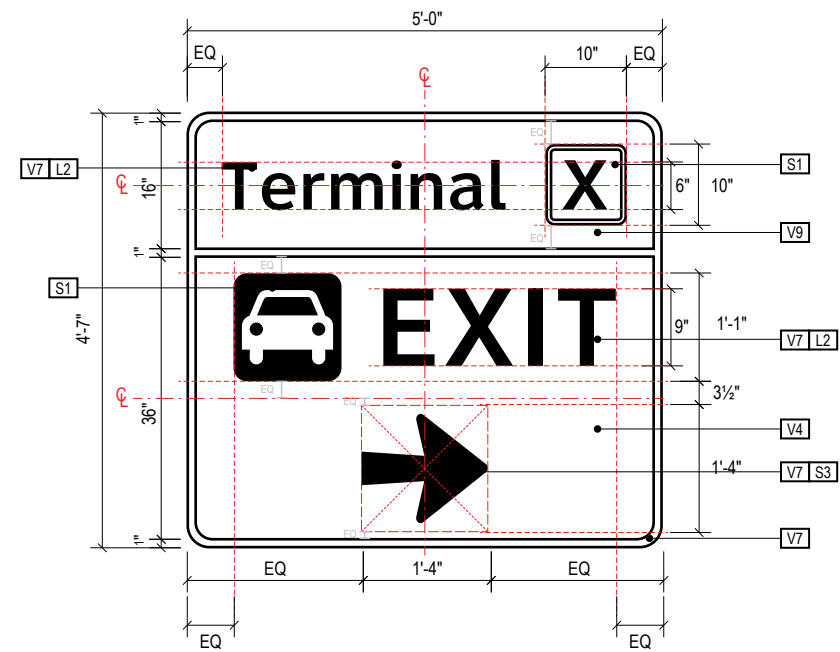

B ALTERNATE FACE LAYOUT OPTION (through garage)
Scale: 1/2" = 1'-0"

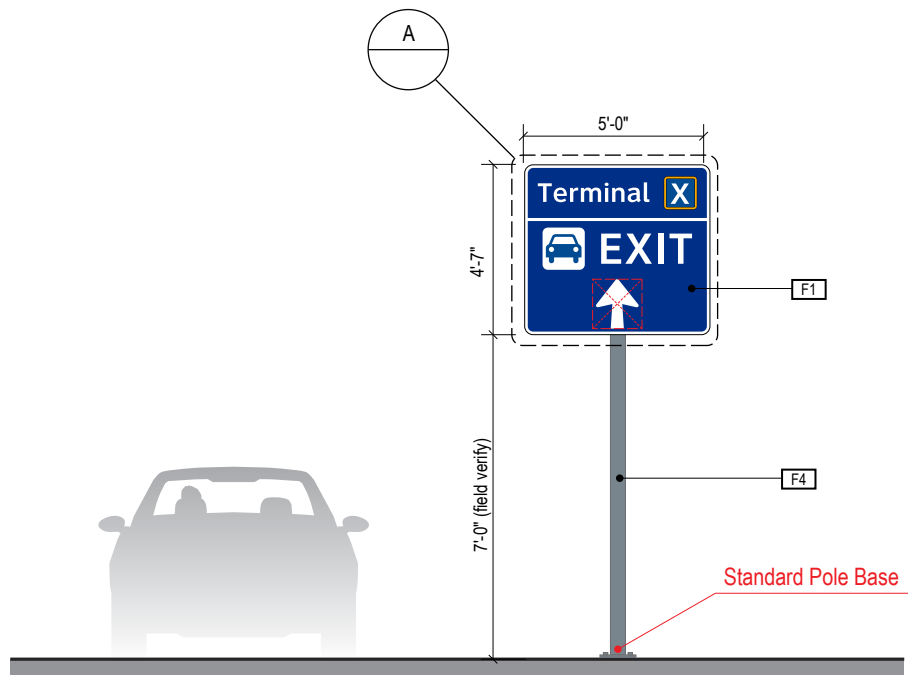

2 ELEVATION w/ Standard Base
Scale: 3/16" = 1'-0"

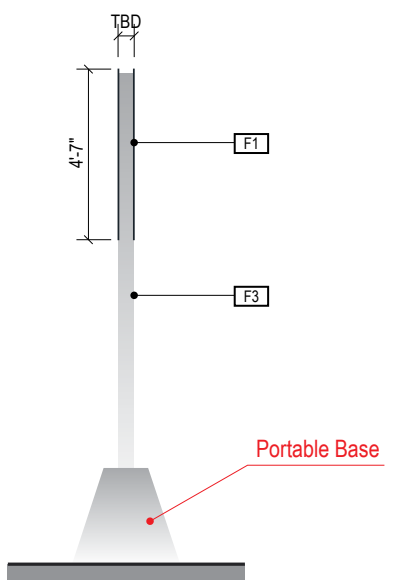

3 END VIEW
Scale: 3/16" = 1'-0"

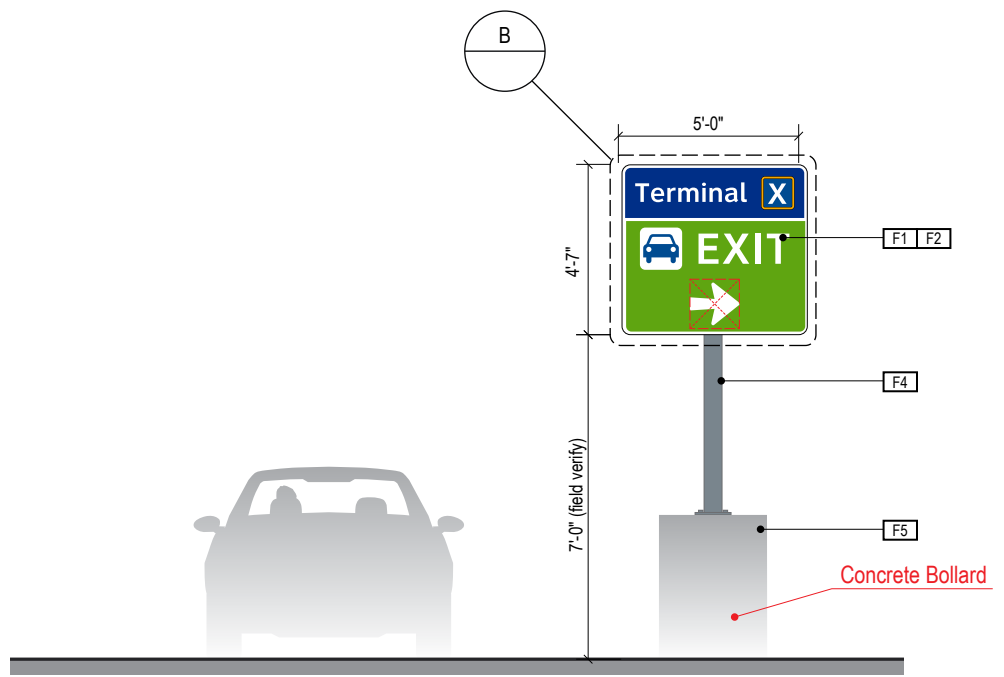

4 ELEVATION w/ Existing Concrete Bollard
Scale: 3/16" = 1'-0"

- GENERAL NOTES**
- All final design, engineering, and amount/sizing of structural sign support elements, material types/thicknesses, dimensions, and attachment methods shall be performed and approved by a licensed engineer to meet or exceed all applicable local and national codes.
 - Final engineering, dimensions, materials, and fabrication are the responsibility of the Fabricator to ensure the highest quality fit and finish for all components of the completed product. All final detailing and specifications to be provided by the Fabricator within their final approved fabrication-ready shop drawings.
 - Wherever dissimilar metals are in contact, always separate contact surfaces prior to assembly or installation with the necessary protective coatings/gaskets/washers to prevent galvanic corrosion.
 - Final fabrication methods, quality and fit/finish to be reviewed and approved by DFW Planning Department and wayfinding/architecture Design Consultants thru prototype reviews prior to final production run/installation processes (see Performance Specifications for details).
 - Colors shown are for reference only, and are subject to the limitations of the printing process and/or variance of electronic RGB screen displays. Refer to color system swatches and/or final finish samples for accurate reference.
 - Messages shown here are general placeholders only. See graphic message schedules for specific messaging by location and sign type.

- FABRICATION INTENT NOTES**
- F1** SIGN FACE PANELS: 1/4" thick aluminum sign face panels; mechanically fasten sign panels to support tube structure with stainless steel tamper-proof screws, paint heads to match sign face; digitally printed full-bleed color graphics on 3M Reflective DG3 4090 White film applied to 1st surface of face panels; all exposed surfaces, returns, etc to be painted with MAP paint to match P1, satin finish
 - F2** SUPPORT FRAME/POST ATTACHMENT: fabricated 1" square aluminum support tube frame structure; all exposed support frame tube ends to be capped with aluminum; all welds on frame/caps to be filled and ground smooth for uniform appearance; support frame mechanically attached to support post as required w/ mech. fasteners (fabricator to field verify); support frame to be painted all exposed surfaces with MAP paint to match P2, satin finish
 - F3** PORTABLE PYRAMID BASE and POLE: By others. Mount per manufacturer recommendations.
 - F4** SUPPORT POST: Fabricated square aluminum vertical support post tube; support post tube end to be capped with aluminum; all welds on frame/caps to be filled and ground smooth for uniform appearance; support post welded to foot plate and mechanically attached to concrete bollard; all support post/attachment plate/fasteners and exposed surfaces to be painted with MAP paint to match P2, satin finish
 - F5** EXISTING CONCRETE BOLLARD: Existing concrete bollard

- GRAPHICS / COLORS / DECORATION NOTES**
- L2** Typeface: font = Clearview/Text Bold
 - S1** Universal Symbols: AIGA/TXDOT style symbol artwork
 - S3** Veh. Arrow(s): use only official MUTCD/TXDOT arrow art
- VINYL (FILM) / DIGITAL PRINT:
- V4** Light Green: match PMS 368C
 - V7** White: 3M 4090 DG3 White (Reflective)
 - V9** Blue: 3M 4095 DG3 Blue (Reflective)
- PAINT:
- P2** Silver: Matthews Paint #MP30136 Brushed Aluminum, satin finish

ILLUMINATION	SIGN TYPE	SIGN FUNCTION	MOUNTING METHOD	GENERAL DESCRIPTION & USE
REFLECTIVE	5-DR.54	DIRECTIONAL	POST MOUNT	VEHICULAR - Roadside/Roof Charging Station

GENERAL NOTES

- All final design, engineering, and amount/sizing of structural sign support elements, material types/thicknesses, dimensions, and attachment methods shall be performed and approved by a licensed engineer to meet or exceed all applicable local and national codes.
- Final engineering, dimensions, materials, and fabrication are the responsibility of the Fabricator to ensure the highest quality fit and finish for all components of the completed product. All final detailing and specifications to be provided by the Fabricator within their final approved fabrication-ready shop drawings.
- Wherever dissimilar metals are in contact, always separate contact surfaces prior to assembly or installation with the necessary protective coatings/gaskets/washers to prevent galvanic corrosion.
- Final fabrication methods, quality and fit/finish to be reviewed and approved by DFW Planning Department and wayfinding/architecture Design Consultants thru prototype reviews prior to final production run/installation processes (see Performance Specifications for details).
- Colors shown are for reference only, and are subject to the limitations of the printing process and/or variance of electronic RGB screen displays. Refer to color system swatches and/or final finish samples for accurate reference.
- Messages shown here are general placeholders only. See graphic message schedules for specific messaging by location and sign type.

FABRICATION INTENT NOTES

- F1** SIGN FACE PANELS: 1/4" thick aluminum sign face panels; mechanically fasten sign panels to support tube structure with stainless steel tamper-proof screws, paint heads to match sign face; digitally printed full-bleed color graphics on 3M Reflective DG3 4090 White film applied to 1st surface of face panels; all exposed surfaces, returns, etc to be painted with MAP paint to match P1, satin finish
- F2** SUPPORT FRAME/POST ATTACHMENT: fabricated 1" square aluminum support tube frame structure; all exposed support frame tube ends to be capped with aluminum; all welds on frame/caps to be filled and ground smooth for uniform appearance; support frame mechanically attached to support post as required w/ mech. fasteners (fabricator to field verify); support frame to be painted all exposed surfaces with MAP paint to match P2, satin finish
- F3** PORTABLE PYRAMID BASE and POLE: By others. Mount per manufacturer recommendations.
- F4** SUPPORT POST: Fabricated square aluminum vertical support post tube; support post tube end to be capped with aluminum; all welds on frame/caps to be filled and ground smooth for uniform appearance; support post welded to foot plate and mechanically attached to concrete bollard; all support post/attachment plate/fasteners and exposed surfaces to be painted with MAP paint to match P2, satin finish
- F5** EXISTING CONCRETE BOLLARD: Existing concrete bollard

GRAPHICS / COLORS / DECORATION NOTES

- L2** Typeface: font = ClearviewText Bold
 - S1** Universal Symbols: AIGA/TXDOT style symbol artwork
 - S3** Veh. Arrow(s): use only official MUTCD/TXDOT arrow art
- VINYL (FILM) / DIGITAL PRINT:
- V4** Light Green: match PMS 368C
 - V7** White: 3M 4090 DG3 White (Reflective)
 - V9** Blue: 3M 4095 DG3 Blue (Reflective)
- PAINT:
- TP1** White: PMS White C, Type DMS-8200 Traffic Paint
 - TP2** Green: to match PMS 7482 C Traffic Paint

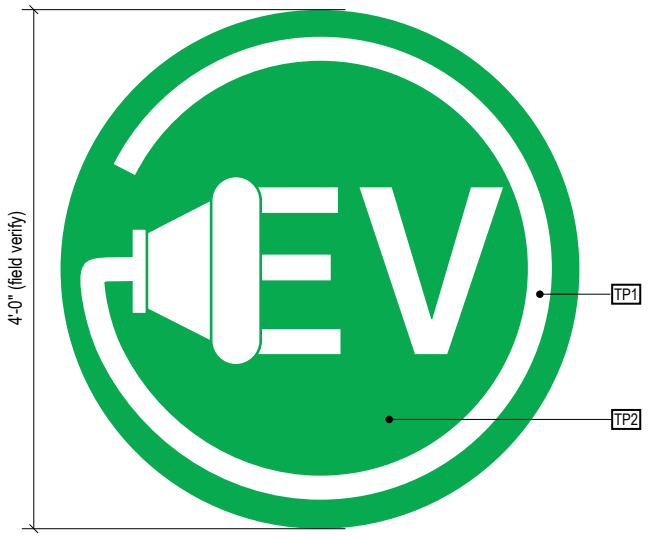
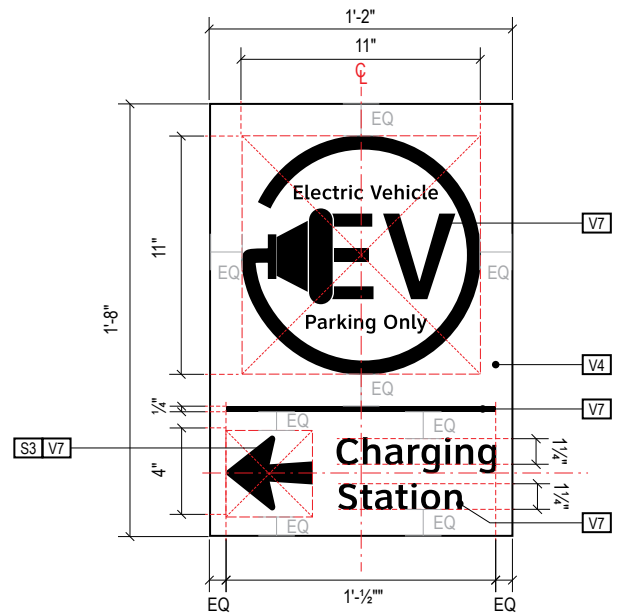

1 PLAN VIEW
Scale: NTS

A FACE LAYOUT
Scale: NTS

B CHARGING STATION PAVEMENT MARKING
Scale: NTS

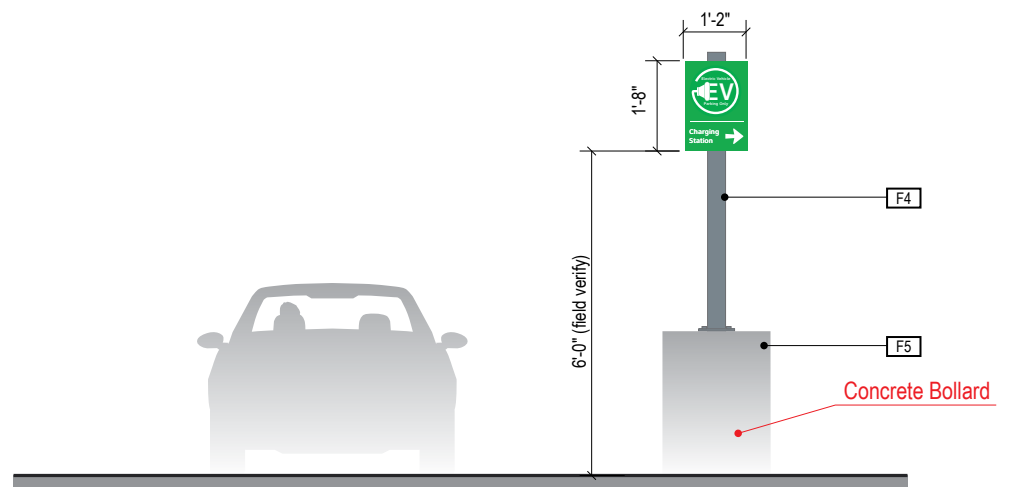
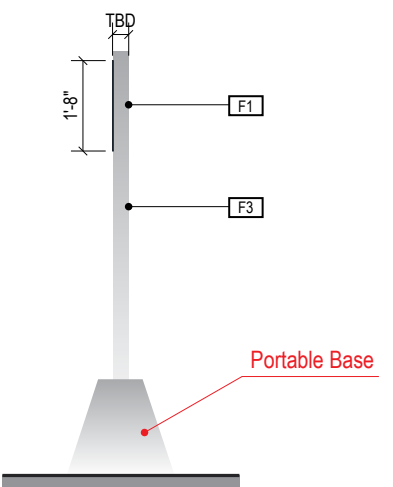
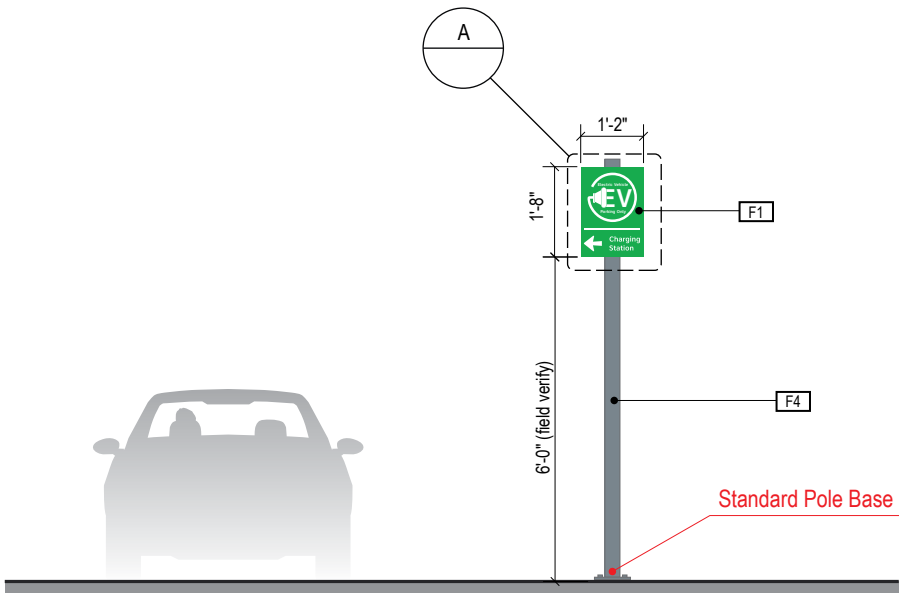

2 ELEVATION w/ Standard Base
Scale: NTS

3 END VIEW
Scale: NTS

4 ELEVATION w/ Existing Concrete Bollard
Scale: NTS

ILLUMINATION	SIGN TYPE	SIGN FUNCTION	MOUNTING METHOD	GENERAL DESCRIPTION & USE
NON-ILLUMINATED	5-ID.01	IDENTIFICATION	WALL/BEAM/COLUMN	VEHICULAR - Ramp Entry ID Graphics

GENERAL NOTES

- All final design, engineering, and amount/sizing of structural sign support elements, material types/thicknesses, dimensions, and attachment methods shall be performed and approved by a licensed engineer to meet or exceed all applicable local and national codes.
- Final engineering, dimensions, materials, and fabrication are the responsibility of the Fabricator to ensure the highest quality fit and finish for all components of the completed product. All final detailing and specifications to be provided by the Fabricator within their final approved fabrication-ready shop drawings.
- Wherever dissimilar metals are in contact, always separate contact surfaces prior to assembly or installation with the necessary protective coatings/gaskets/washers to prevent galvanic corrosion.
- Final fabrication methods, quality and fit/finish to be reviewed and approved by DFW Planning Department and wayfinding/architecture Design Consultants thru prototype reviews prior to final production run/installation processes (see Performance Specifications for details).
- Colors shown are for reference only, and are subject to the limitations of the printing process and/or variance of electronic RGB screen displays. Refer to color system swatches and/or final finish samples for accurate reference.
- Messages shown here are general placeholders only. See graphic message schedules for specific messaging by location and sign type.

FABRICATION INTENT NOTES

- F1** BACKGROUND AREA: paint existing background area with MAP paint, satin finish; field verify existing background surface area conditions and prep with primer prior to painting per paint manufacturer's specifications
- F2** ARROW GRAPHICS: paint arrow with MAP paint, satin finish; field verify existing background surface area conditions and prep with primer prior to painting per paint manufacturer's specifications
- F3** LARGE EXIT LETTERS: paint letters with MAP paint, satin finish; field verify existing background surface area conditions and prep with primer prior to painting per paint manufacturer's specifications

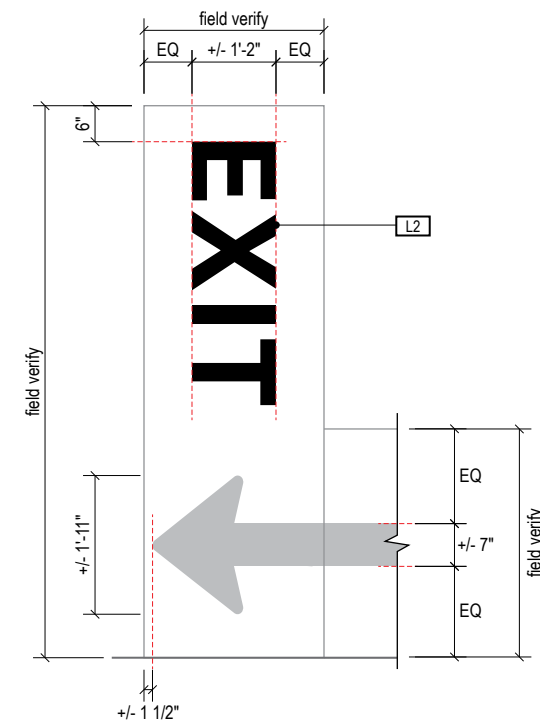

A FACE LAYOUT
Scale: 3/8" = 1'-0"

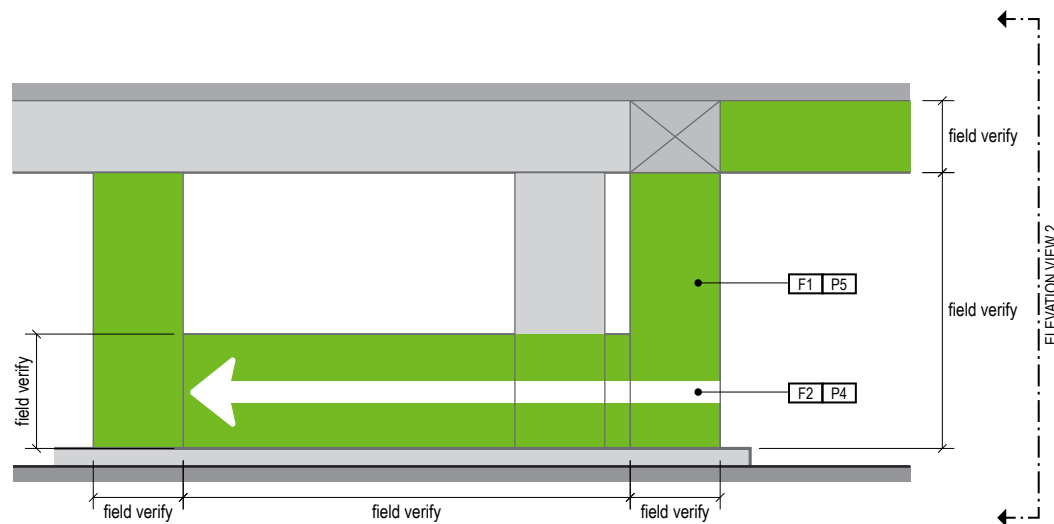

1 ELEVATION: Ramp Entrance Inner Wall Area (Typical)
Scale: 3/16" = 1'-0"

NOTE: Elevation shown is typical example only; elevation varies per level and each garage vehicular ramp entrance location; field verify each location

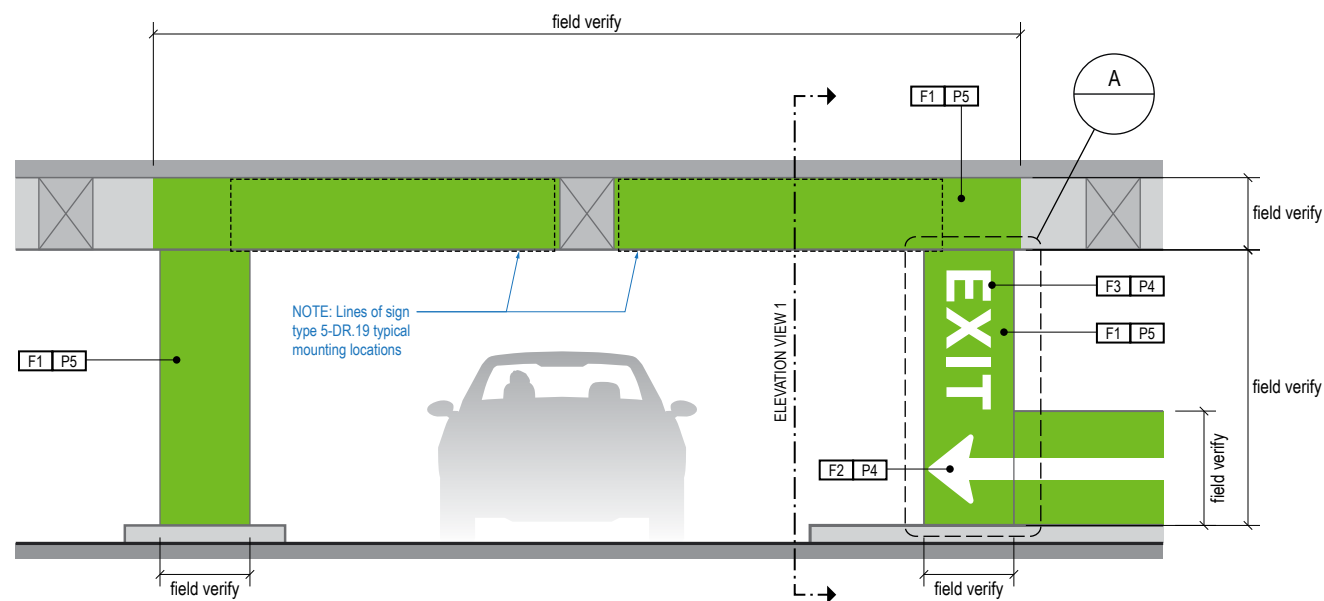

2 ELEVATION: Ramp Entrance Threshold Area (Typical)
Scale: 3/16" = 1'-0"

NOTE: Elevation shown is typical example only; elevation varies per level and each garage vehicular ramp entrance location; field verify each location

GRAPHICS / COLORS / DECORATION NOTES

- L2** Typeface: ClearviewText Bold
- PAINT:
- P4** White: MAP paint # MP05317, satin fin.
- P5** Exit Light Green: MAP paint to match PMS 368C, satin fin.

ILLUMINATION	SIGN TYPE	SIGN FUNCTION	MOUNTING METHOD	GENERAL DESCRIPTION & USE
REFLECTIVE	5-ID.51	IDENTIFICATION	WALL/COLUMN	PEDESTRIAN - Wall/Column Mount Garage Section ID; 1 side

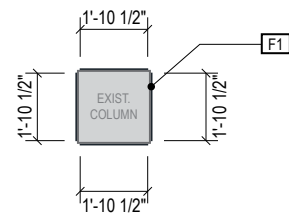

1 PLAN VIEW
Scale: 3/16" = 1'-0"

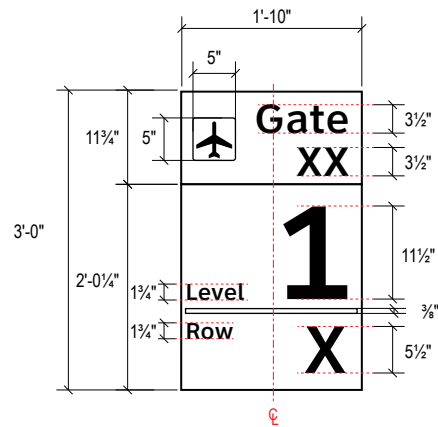

A FACE LAYOUT: Row Sides
Scale: 1/2" = 1'-0"

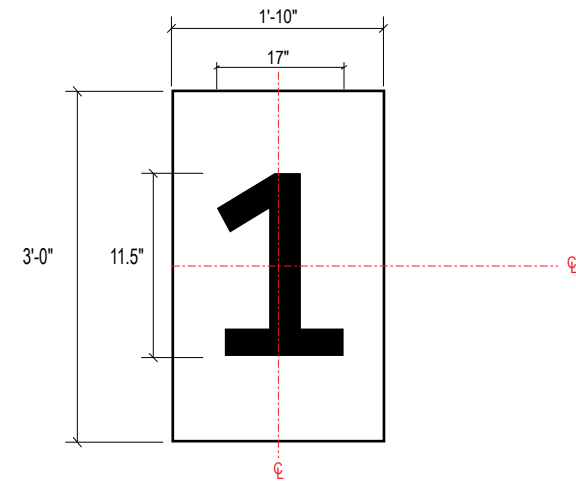

B FACE LAYOUT: Non-Row Sides
Scale: 1/2" = 1'-0"

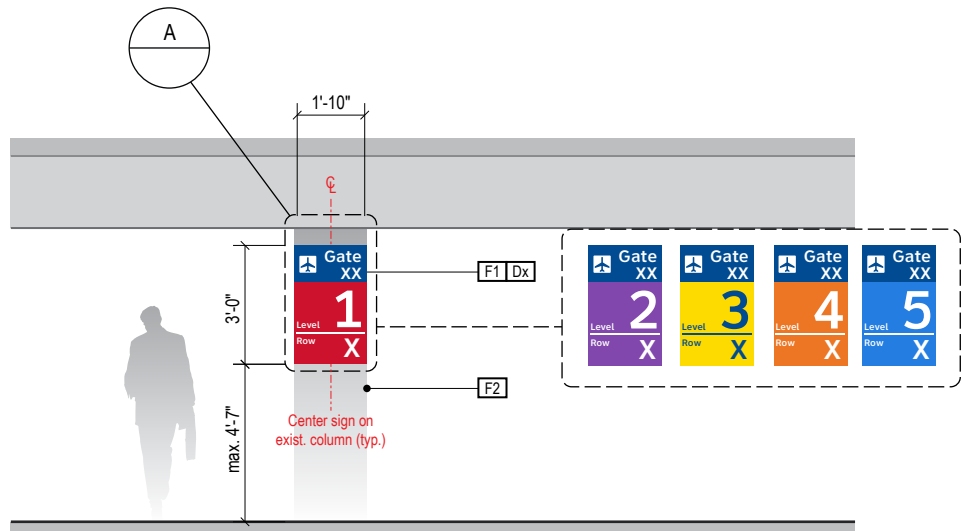

2 ELEVATION: Row Sides
Scale: 3/16" = 1'-0"

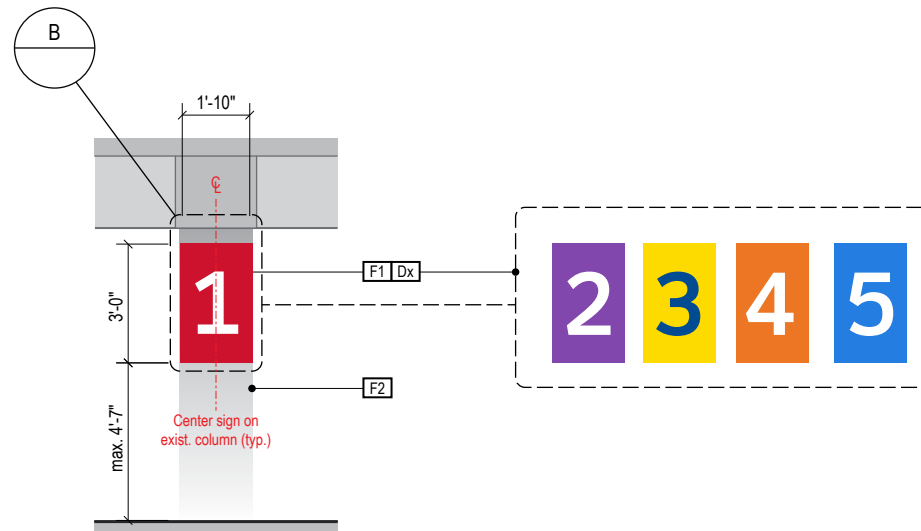

3 Non-Row Sides
Scale: 3/16" = 1'-0"

GENERAL NOTES

- All final design, engineering, and amount/sizing of structural sign support elements, material types/thicknesses, dimensions, and attachment methods shall be performed and approved by a licensed engineer to meet or exceed all applicable local and national codes.
- Final engineering, dimensions, materials, and fabrication are the responsibility of the Fabricator to ensure the highest quality fit and finish for all components of the completed product. All final detailing and specifications to be provided by the Fabricator within their final approved fabrication-ready shop drawings.
- Wherever dissimilar metals are in contact, always separate contact surfaces prior to assembly or installation with the necessary protective coatings/gaskets/washers to prevent galvanic corrosion.
- Final fabrication methods, quality and fit/finish to be reviewed and approved by DFW Planning Department and wayfinding/architecture Design Consultants thru prototype reviews prior to final production run/installation processes (see Performance Specifications for details).
- Colors shown are for reference only, and are subject to the limitations of the printing process and/or variance of electronic RGB screen displays. Refer to color system swatches and/or final finish samples for accurate reference.
- Messages shown here are general placeholders only. See graphic message schedules for specific messaging by location and sign type.

FABRICATION INTENT NOTES

- F1** SIGN FACE PANELS: 1/8" thick aluminum sign face panels; mechanically fasten sign panels to garage support column/walls as install conditions require (field verify); digitally printed full-bleed color graphics on 3M Reflective DG3 4090 White film applied to 1st surface of face panels.
- F2** COLUMNS: existing garage vertical support column; fabricator to field verify column conditions and engineer sign attachment to columns as install locations require.

GRAPHICS / COLORS / DECORATION NOTES

- L1** Typeface: font = ClearviewText Medium
- S1** Universal Symbols: use only official DFW symbol artwork

VINYL (FILM) / DIGITAL PRINT:

- Dx** DFW Wayfinding Blue: to match PMS 662C
- Garage Level ID Digital Print Colors:
 - Level 1: Red = to match PMS 186C
 - Level 2: Purple = to match PMS 2587C
 - Level 3: Yellow = to match PMS 108C
 - Level 4: Orange = to match PMS 158C
 - Level 5: Blue = to match PMS 2727C

WARNING:

This record contains Sensitive Security Information that is controlled under 49 CFR parts 15 and 1520. No part of this record may be disclosed to persons with a "need to know," as defined in 49 CFR parts 15 and 1520, except with the written permission of the Administrator of the Transportation Security Administration or the Secretary of Transportation. Unauthorized release may result in civil penalty or other action. For U.S. government agencies, public disclosure is governed by 5 U.S.C. 552 and 49 CFR parts 15 and 1520.

ILLUMINATION	SIGN TYPE	SIGN FUNCTION	MOUNTING METHOD	GENERAL DESCRIPTION & USE
REFLECTIVE	5-ID.53	IDENTIFICATION	WALL/COLUMN	VEHEACLE - Wall/Column Mount Garage Section ID; 1 side

GENERAL NOTES

- All final design, engineering, and amount/sizing of structural sign support elements, material types/thicknesses, dimensions, and attachment methods shall be performed and approved by a licensed engineer to meet or exceed all applicable local and national codes.
- Final engineering, dimensions, materials, and fabrication are the responsibility of the Fabricator to ensure the highest quality fit and finish for all components of the completed product. All final detailing and specifications to be provided by the Fabricator within their final approved fabrication-ready shop drawings.
- Wherever dissimilar metals are in contact, always separate contact surfaces prior to assembly or installation with the necessary protective coatings/gaskets/washers to prevent galvanic corrosion.
- Final fabrication methods, quality and fit/finish to be reviewed and approved by DFW Planning Department and wayfinding/architecture Design Consultants thru prototype reviews prior to final production run/installation processes (see Performance Specifications for details).
- Colors shown are for reference only, and are subject to the limitations of the printing process and/or variance of electronic RGB screen displays. Refer to color system swatches and/or final finish samples for accurate reference.
- Messages shown here are general placeholders only. See graphic message schedules for specific messaging by location and sign type.

FABRICATION INTENT NOTES

- F1** SIGN FACE PANELS: 1/8" thick aluminum sign face panels; mechanically fasten sign panels to garage support column/walls as install conditions require (field verify); digitally printed full-bleed color graphics on 3M Reflective DG3 4090 White film applied to 1st surface of face panels.
- F2** COLUMNS: existing garage vertical support column; fabricator to field verify column conditions and engineer sign attachment to columns as install locations require.

GRAPHICS / COLORS / DECORATION NOTES

- L1** Typeface: font = ClearviewText Medium
- S1** Universal Symbols: use only official DFW symbol artwork

COLORS:

- C1** Blue-Gray: PMS 5425C
- C2** Green: PMS 347C
- C3** Dark Blue: PMS 662C

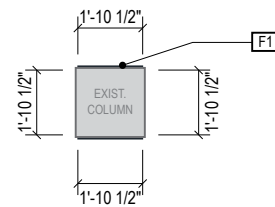

1 PLAN VIEW
Scale: 3/16" = 1'-0"

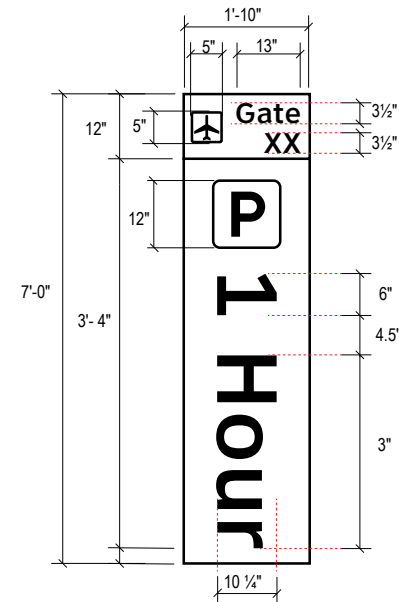

A FACE LAYOUT: Temp. Parking
Scale: 1/2" = 1'-0"

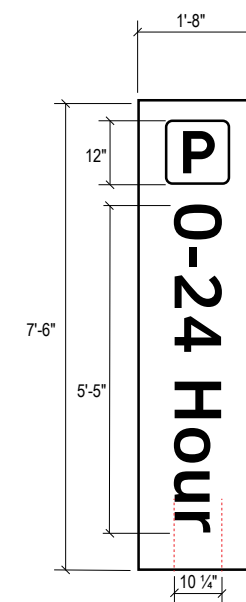

B FACE LAYOUT: D Garage Parking
Scale: 1/2" = 1'-0"

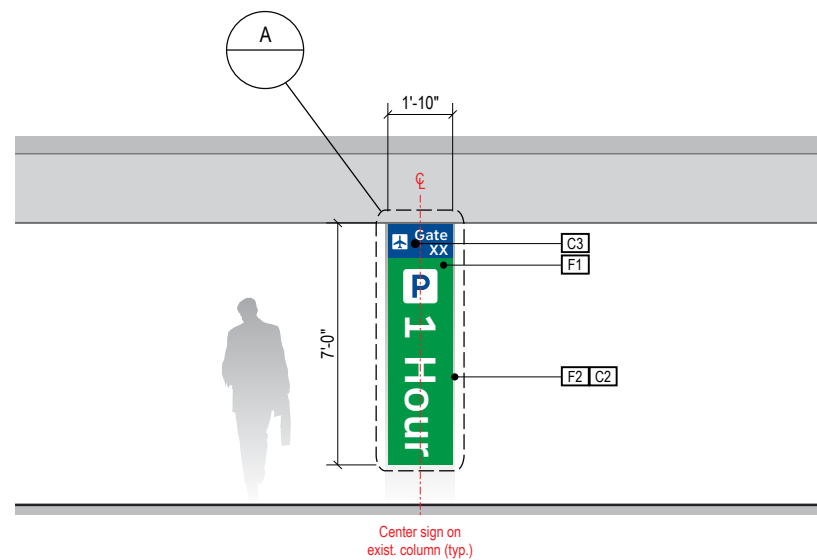

2 ELEVATION: Temp. Parking
Scale: 3/16" = 1'-0"

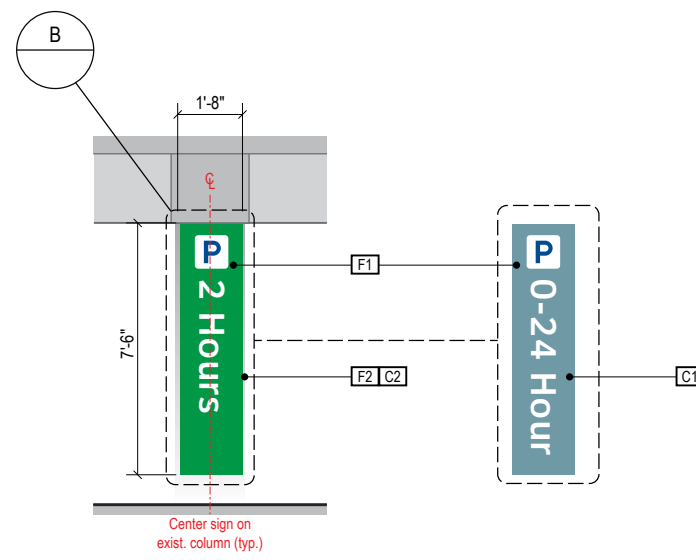

3 D Garage Parking
Scale: 3/16" = 1'-0"

WARNING:

This record contains Sensitive Security Information that is controlled under 49 CFR parts 15 and 1520. No part of this record may be disclosed to persons with a "need to know," as defined in 49 CFR parts 15 and 1520, except with the written permission of the Administrator of the Transportation Security Administration or the Secretary of Transportation. Unauthorized release may result in civil penalty or other action. For U.S. government agencies, public disclosure is governed by 5 U.S.C. 552 and 49 CFR parts 15 and 1520.

ILLUMINATION	SIGN TYPE	SIGN FUNCTION	MOUNTING METHOD	GENERAL DESCRIPTION & USE
REFLECTIVE	5-ID.54	IDENTIFICATION	WALL/COLUMN	PEDESTRIAN - Wall/Column Mount Garage Section ID; 1 side

GENERAL NOTES

- All final design, engineering, and amount/sizing of structural sign support elements, material types/thicknesses, dimensions, and attachment methods shall be performed and approved by a licensed engineer to meet or exceed all applicable local and national codes.
- Final engineering, dimensions, materials, and fabrication are the responsibility of the Fabricator to ensure the highest quality fit and finish for all components of the completed product. All final detailing and specifications to be provided by the Fabricator within their final approved fabrication-ready shop drawings.
- Wherever dissimilar metals are in contact, always separate contact surfaces prior to assembly or installation with the necessary protective coatings/gaskets/washers to prevent galvanic corrosion.
- Final fabrication methods, quality and fit/finish to be reviewed and approved by DFW Planning Department and wayfinding/architecture Design Consultants thru prototype reviews prior to final production run/installation processes (see Performance Specifications for details).
- Colors shown are for reference only, and are subject to the limitations of the printing process and/or variance of electronic RGB screen displays. Refer to color system swatches and/or final finish samples for accurate reference.
- Messages shown here are general placeholders only. See graphic message schedules for specific messaging by location and sign type.

FABRICATION INTENT NOTES

F1 SIGN FACE PANELS: 1/8" thick aluminum sign face panels; mechanically fasten sign panels to garage support column/walls as install conditions require (field verify); digitally printed full-bleed color graphics on 3M Reflective DG3 4090 White film applied to 1st surface of face panels.

F2 COLUMNS: existing garage vertical support column; fabricator to field verify column conditions and engineer sign attachment to columns as install locations require.

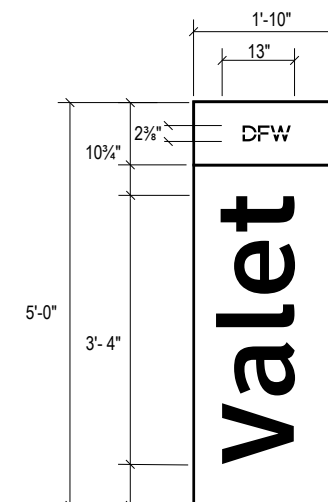

A FACE LAYOUT: Valet
Scale: 1/2" = 1'-0"

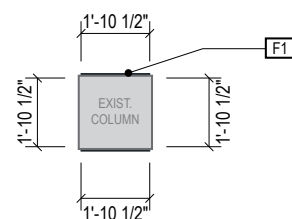

1 PLAN VIEW
Scale: 3/16" = 1'-0"

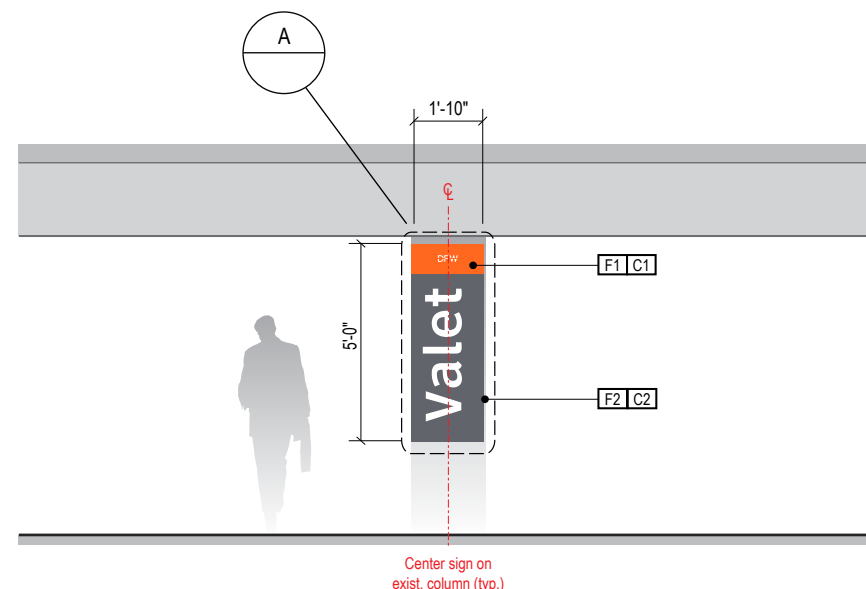

2 ELEVATION: Valet Parking
Scale: 3/16" = 1'-0"

GRAPHICS / COLORS / DECORATION NOTES

- L1** Typeface: font = ClearviewText Medium
- S1** Universal Symbols: use only official DFW symbol artwork

COLORS:

- C1** Gray: Cool Gray 11C
- C2** Orange: PMS 166 C

WARNING:

This record contains Sensitive Security Information that is controlled under 49 CFR parts 15 and 1520. No part of this record may be disclosed to persons with a "need to know," as defined in 49 CFR parts 15 and 1520, except with the written permission of the Administrator of the Transportation Security Administration or the Secretary of Transportation. Unauthorized release may result in civil penalty or other action. For U.S. government agencies, public disclosure is governed by 5 U.S.C. 552 and 49 CFR parts 15 and 1520.

ILLUMINATION	SIGN TYPE	SIGN FUNCTION	MOUNTING METHOD	GENERAL DESCRIPTION & USE
NON-ILLUMINATED	5-ID.55	IDENTIFICATION	WALL MOUNT	PEDESTRIAN - Large Wall Mount Garage Entrance ID (Typical)

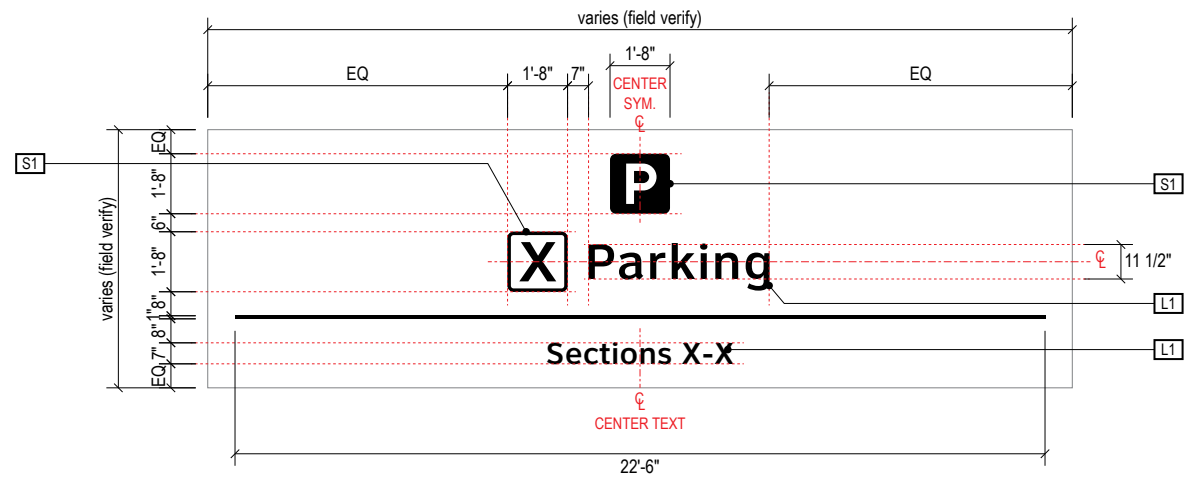

A DETAIL A: Face Layout (Typical)
Scale: 3/16" = 1'-0"

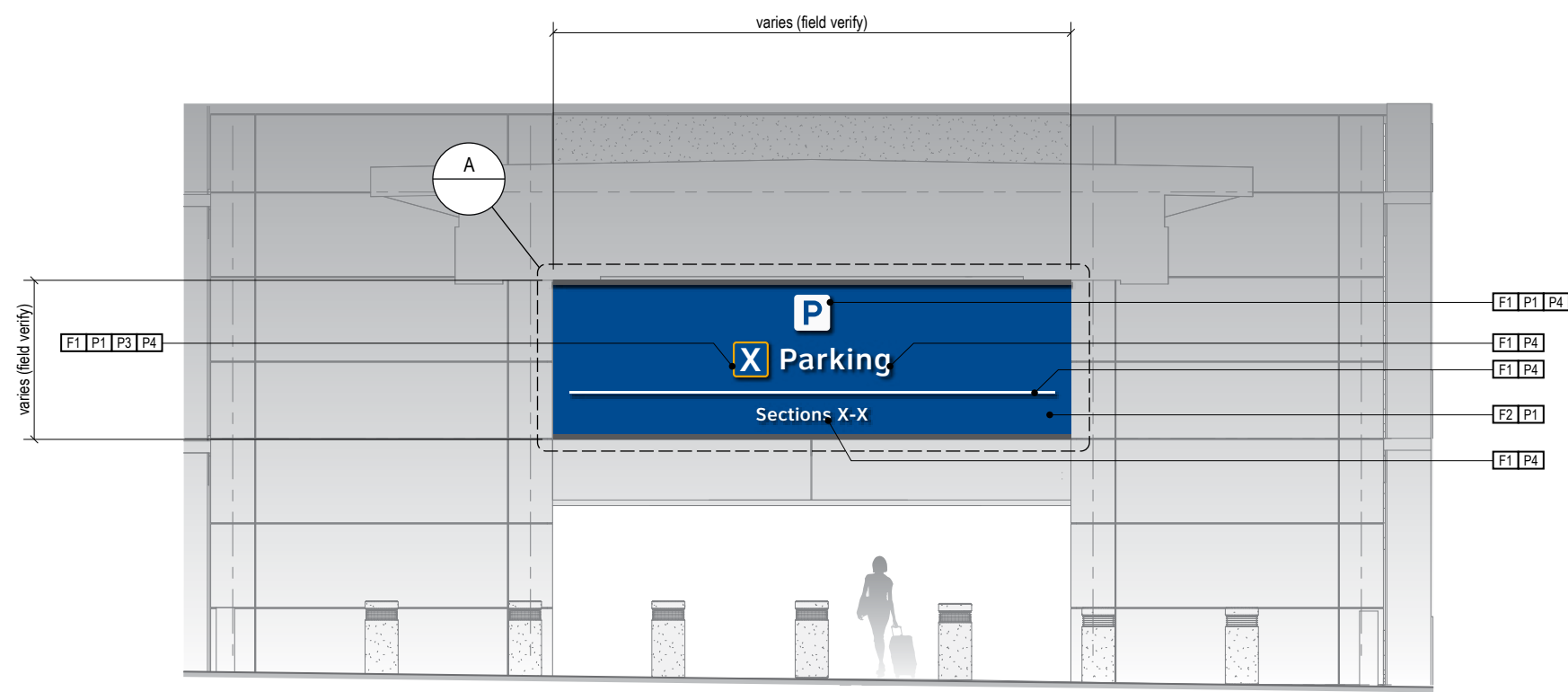

1 ELEVATION (TYPICAL)
Scale: 1/8" = 1'-0"

NOTE: Elevation shown is typical example only; elevation varies per level and each garage pedestrian entrance location; field verify each location

- GENERAL NOTES**
- All final design, engineering, and amount/sizing of structural sign support elements, material types/thicknesses, dimensions, and attachment methods shall be performed and approved by a licensed engineer to meet or exceed all applicable local and national codes.
 - Final engineering, dimensions, materials, and fabrication are the responsibility of the Fabricator to ensure the highest quality fit and finish for all components of the completed product. All final detailing and specifications to be provided by the Fabricator within their final approved fabrication-ready shop drawings.
 - Wherever dissimilar metals are in contact, always separate contact surfaces prior to assembly or installation with the necessary protective coatings/gaskets/washers to prevent galvanic corrosion.
 - Final fabrication methods, quality and fit/finish to be reviewed and approved by DFW Planning Department and wayfinding/architecture Design Consultants thru prototype reviews prior to final production run/installation processes (see Performance Specifications for details).
 - Colors shown are for reference only, and are subject to the limitations of the printing process and/or variance of electronic RGB screen displays. Refer to color system swatches and/or final finish samples for accurate reference.
 - Messages shown here are general placeholders only. See graphic message schedules for specific messaging by location and sign type.
- FABRICATION INTENT NOTES**
- F1** CHANNEL LETTERS: 2" deep channel letter; General Contractor to coordinate with stainless steel mesh manufacturer for typical attachment details as required.; mount to wall structural elements with connection system as installation location conditions require; provide seal at all exterior wall penetrations (Fabricator to coordinate connection location/type of structural elements with General Contractor)
 - F2** BACKGROUND AREA: paint existing area with MAP paint, satin finish; field verify existing background surface area conditions and prep with primer prior to painting per paint manufacturer's specifications

- GRAPHICS / COLORS / DECORATION NOTES**
- L1** Typeface: font = ClearviewText Medium
 - S1** Universal Symbols: use only official DFW symbol artwork
- PAINT:**
- P1** Blue: MAP paint to match PMS 662C, satin finish
 - P3** Yellow: MAP paint to match PMS 130C, satin finish
 - P4** White: MAP paint # MP05317, satin finish

ILLUMINATION	SIGN TYPE	SIGN FUNCTION	MOUNTING METHOD	GENERAL DESCRIPTION & USE
NON-ILLUMINATED	5-ID.56	IDENTIFICATION	WALL MOUNT	PEDESTRIAN - Wall Mount Roof Level Elevator Garage/Level ID (Typical)

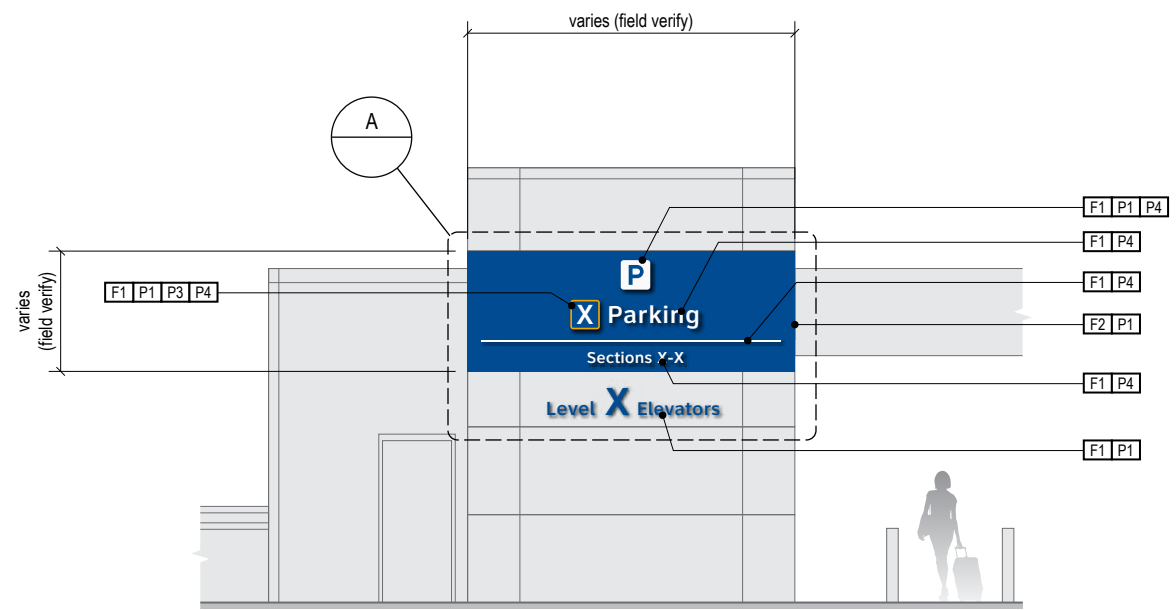
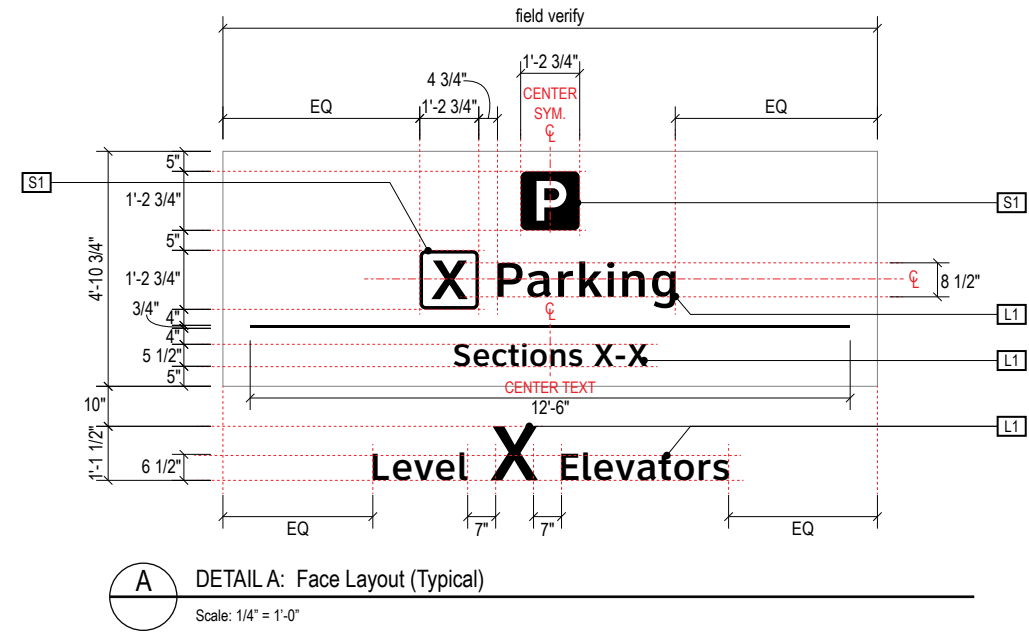

1 ELEVATION (TYPICAL)
Scale: 1/8" = 1'-0"

NOTE: Elevation shown is typical example only; elevation varies per level and each garage pedestrian entrance location; field verify each location

GENERAL NOTES

- All final design, engineering, and amount/sizing of structural sign support elements, material types/thicknesses, dimensions, and attachment methods shall be performed and approved by a licensed engineer to meet or exceed all applicable local and national codes.
- Final engineering, dimensions, materials, and fabrication are the responsibility of the Fabricator to ensure the highest quality fit and finish for all components of the completed product. All final detailing and specifications to be provided by the Fabricator within their final approved fabrication-ready shop drawings.
- Wherever dissimilar metals are in contact, always separate contact surfaces prior to assembly or installation with the necessary protective coatings/gaskets/washers to prevent galvanic corrosion.
- Final fabrication methods, quality and fit/finish to be reviewed and approved by DFW Planning Department and wayfinding/architecture Design Consultants thru prototype reviews prior to final production run/installation processes (see Performance Specifications for details).
- Colors shown are for reference only, and are subject to the limitations of the printing process and/or variance of electronic RGB screen displays. Refer to color system swatches and/or final finish samples for accurate reference.
- Messages shown here are general placeholders only. See graphic message schedules for specific messaging by location and sign type.

FABRICATION INTENT NOTES

- F1** CHANNEL LETTERS: 2" deep channel letter; General Contractor to coordinate with stainless steel mesh manufacturer for typical attachment details as required.; mount to wall structural elements with connection system as installation location conditions require; provide seal at all exterior wall penetrations (Fabricator to coordinate connection location/type of structural elements with General Contractor)
- F2** BACKGROUND AREA: paint existing area with MAP paint, satin finish; field verify existing background surface area conditions and prep with primer prior to painting per paint manufacturer's specifications

GRAPHICS / COLORS / DECORATION NOTES

- L1** Typeface: font = ClearviewText Medium
- S1** Universal Symbols: use only official DFW symbol artwork
- PAINT:**
- P1** Blue: MAP paint to match PMS 662C, satin finish
- P3** Yellow: MAP paint to match PMS 130C, satin finish
- P4** White: MAP paint # MP05317, satin finish

ILLUMINATION	SIGN TYPE	SIGN FUNCTION	MOUNTING METHOD	GENERAL DESCRIPTION & USE
NON-ILLUMINATED	5-ID.65	IDENTIFICATION	WALL MOUNT	PEDESTRIAN - Wall Mount Elevator Level ID/Directory

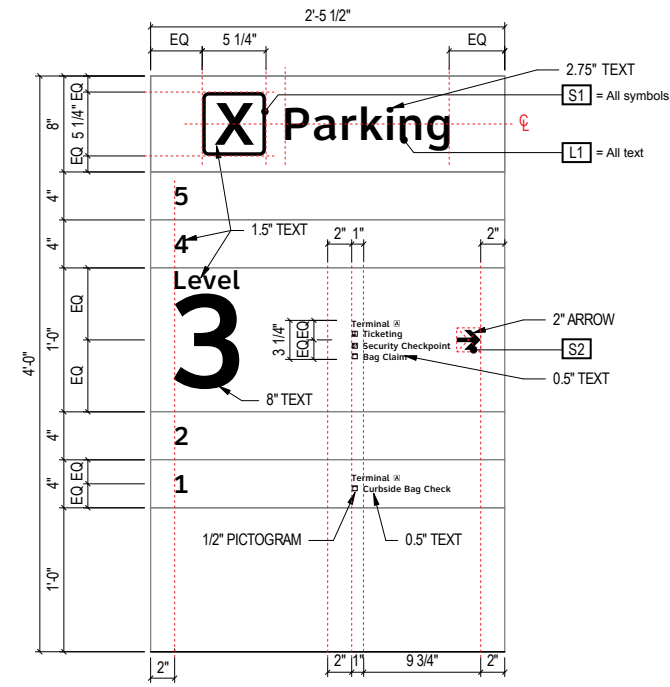

A DETAIL A: Face Layout
Scale: 3/4" = 1'-0"

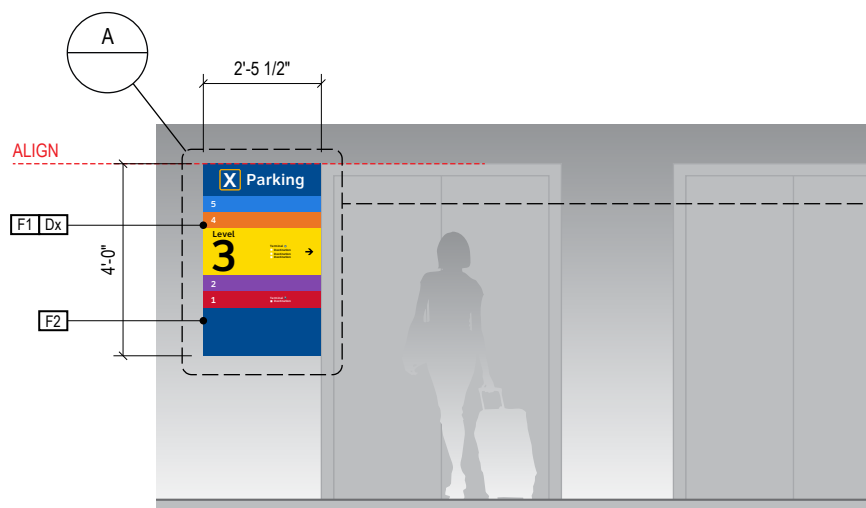

1 ELEVATION (TYPICAL)
Scale: 1/4" = 1'-0"

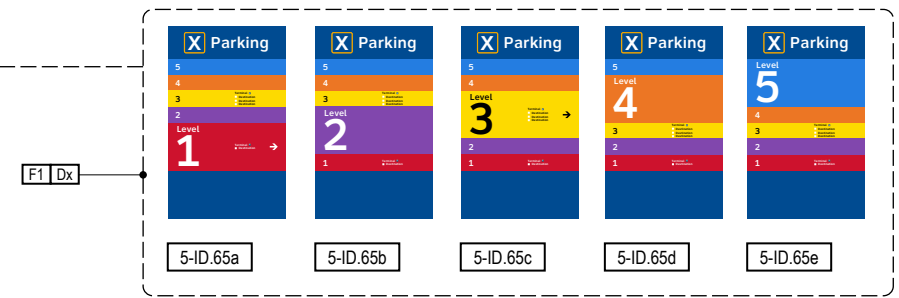

GENERAL NOTES

- All final design, engineering, and amount/sizing of structural sign support elements, material types/thicknesses, dimensions, and attachment methods shall be performed and approved by a licensed engineer to meet or exceed all applicable local and national codes.
- Final engineering, dimensions, materials, and fabrication are the responsibility of the Fabricator to ensure the highest quality fit and finish for all components of the completed product. All final detailing and specifications to be provided by the Fabricator within their final approved fabrication-ready shop drawings.
- Wherever dissimilar metals are in contact, always separate contact surfaces prior to assembly or installation with the necessary protective coatings/gaskets/washers to prevent galvanic corrosion.
- Final fabrication methods, quality and fit/finish to be reviewed and approved by DFW Planning Department and wayfinding/architecture Design Consultants thru prototype reviews prior to final production run/installation processes (see Performance Specifications for details).
- Colors shown are for reference only, and are subject to the limitations of the printing process and/or variance of electronic RGB screen displays. Refer to color system swatches and/or final finish samples for accurate reference.
- Messages shown here are general placeholders only. See graphic message schedules for specific messaging by location and sign type.

FABRICATION INTENT NOTES

- F1** SIGN PANEL: composite phenolic core unitized sign with integral polymetric face layer and interchangeable message panels
- F2** MOUNTING: mount to wall structural elements with connection system as installation location conditions require

GRAPHICS / COLORS / DECORATION NOTES

- L1** Typeface: font = ClearviewText Medium
- S1** Universal Symbols: use only official DFW symbol artwork

- VINYL (FILM) / DIGITAL PRINT:
- Dx** DFW Wayfinding Blue: to match PMS 662C
 - Garage Level ID Digital Print Colors:
 - Level 1: Red = to match PMS 186C
 - Level 2: Purple = to match PMS 2587C
 - Level 3: Yellow = to match PMS 108C
 - Level 4: Orange = to match PMS 158C
 - Level 5: Blue = to match PMS 2727C

ILLUMINATION	SIGN TYPE	SIGN FUNCTION	MOUNTING METHOD	GENERAL DESCRIPTION & USE
REFLECTIVE	5-ID.20	INFORMATIONAL	POLE MOUNTED	No Pedestrian - Pole Mounted Sign

GENERAL NOTES

- All final design, engineering, and amount/sizing of structural sign support elements, material types/thicknesses, dimensions, and attachment methods shall be performed and approved by a licensed engineer to meet or exceed all applicable local and national codes.
- Final engineering, dimensions, materials, and fabrication are the responsibility of the Fabricator to ensure the highest quality fit and finish for all components of the completed product. All final detailing and specifications to be provided by the Fabricator within their final approved fabrication-ready shop drawings.
- Wherever dissimilar metals are in contact, always separate contact surfaces prior to assembly or installation with the necessary protective coatings/gaskets/washers to prevent galvanic corrosion.
- Final fabrication methods, quality and fit/finish to be reviewed and approved by DFW Airport Planning Department and wayfinding/architecture Design Consultants thru prototype reviews prior to final production run/installation processes (see Performance Specifications for details).
- Colors shown are for reference only, and are subject to the limitations of the printing process and/or variance of electronic RGB screen displays. Refer to color system swatches and/or final finish samples for accurate reference.
- Messages shown here are general placeholders only. See graphic message schedules for specific messaging by location and sign type.

FABRICATION INTENT NOTES

- F1** SIGN CABINET/FRAME: modular fabricated internal illuminated edge-lit sign module cabinet constructed of extruded aluminum and cast aluminum components with concealed internal welds; removable sign face and light modules; fabricated aluminum support frame with welded mitered corners and slotted mounting holes to accept sign mounting brackets; fabricated aluminum sign mounting frame with tapered side end cover panels, attached with aluminum pin and clip system; power feed/units hidden behind mounting frame with access holes in back for wall mounting; powdercoat all exposed surfaces of sign cabinet/support frame/mounting frame to match P1, satin finish
- F2** SIGN FACE: fabricated sign face assembly module constructed of extruded aluminum frame and concealed internal welds; faces are 3/16" white acrylic with 1st surface applied V1 vinyl film, graphics reversed out of blue (white is exposed white acrylic cut-thru blue film); faces illuminated with light panel assembly using LED edge-lit clear inscribed acrylic diffuser and self-contained technology (including electronics, extruded frame and diffuser)
- F3** TRIM: .080 fabricated aluminum trim piece with closed ends; detachable and mounted with keyholes/studs and set screws; paint all exposed surfaces to match P2, satin finish
- F4** MOUNTING: mount to wall structural elements with connection system as installation location conditions require (Fabricator to coordinate connection location/type of structural elements with General Contractor); paint all exposed surfaces to match P1, satin finish

GRAPHICS / COLORS / DECORATION NOTES

- L1** Typeface: font = ClearviewText Medium
- L2** Typeface: font = ClearviewText Bold
- L3** BRAILLE: Grade 2 contracted Braille; must meet all applicable ADA/TAS requirements for tactile signage
- S1** Universal Symbols: AIGA style symbol artwork
- S2** Arrow(s): use only official DFW wayfinding arrow artwork
- VINYL (FILM):
 - V1** Blue: 3M EC 7725-37 Sapphire Blue
 - V2** White: 3M 7725-20 Opaque Matte White
 - V3** Skylink Yellow: 3M 7725-114 Enamel Receptive
 - V4** Exit Light Green: 3M Opaque Matte to match PMS 368C
 - V5** Black: 3M 7725-22 Opaque Matte Black
 - V6** Safety Red: 3M Opaque Matte to match PMS 485C
- PAINT:
 - P1** Blue: Powder coated to match 3M EC 7725-37, satin finish
 - P2** Silver: MAP paint # MP30136, satin finish
 - P3** Skylink Yellow: MAP paint to match PMS 130C, satin finish
 - P4** White: MAP paint # MP05317; photopolymer Braille, satin fin.
 - P5** Light Green: MAP Paint to match PMS 368C, satin finish

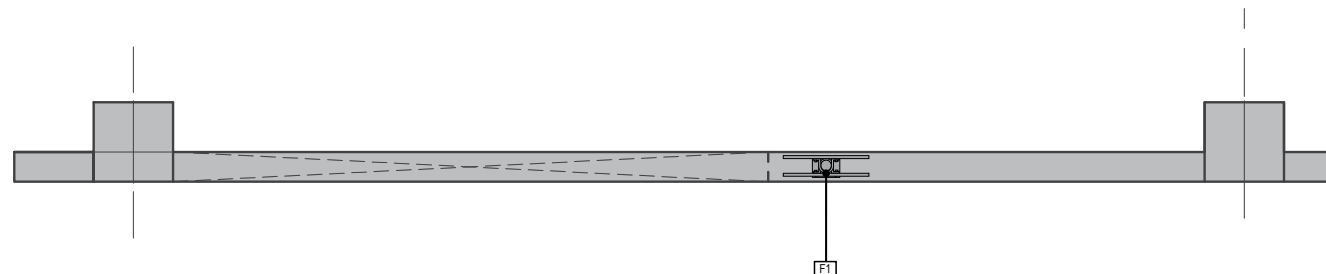

1 PLAN VIEW
Scale: NTS

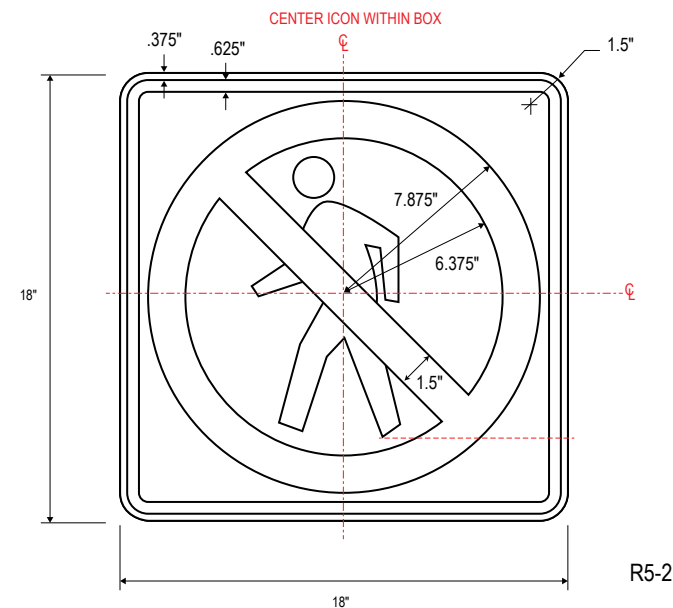

A FACE LAYOUT
Scale: NTS

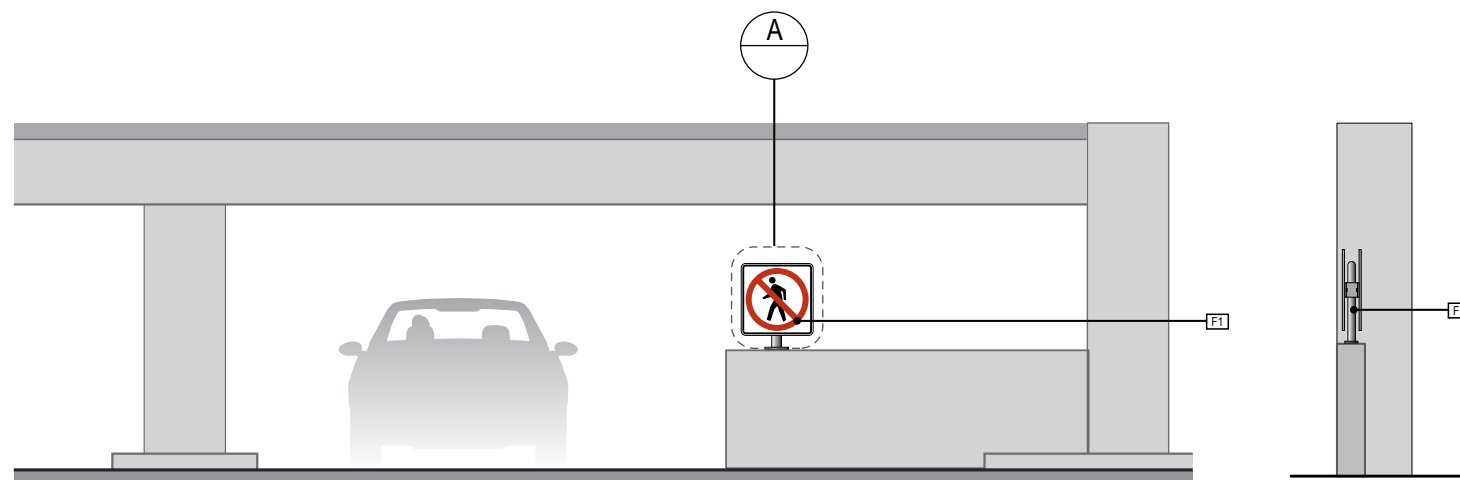

2 ELEVATION
Scale: NTS

3 END VIEW
Scale: NTS

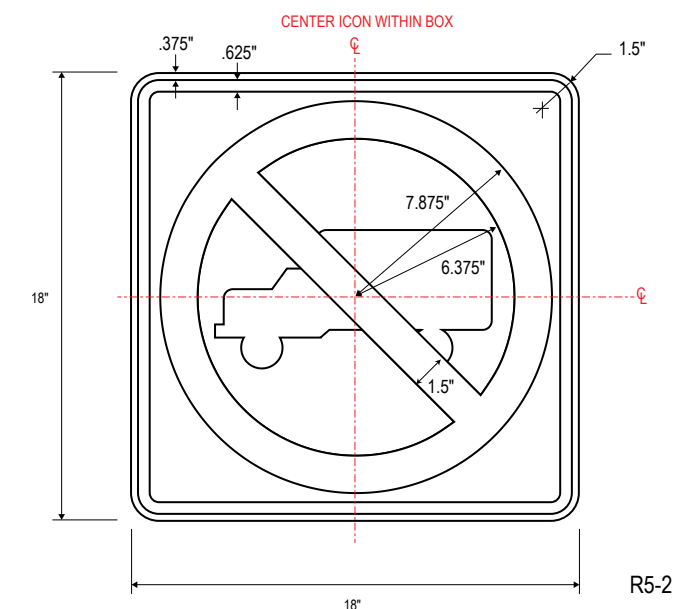

A FACE LAYOUT Alternate Message
Scale: NTS

WARNING:

This record contains Sensitive Security Information that is controlled under 49 CFR parts 15 and 1520. No part of this record may be disclosed to persons with a "need to know," as defined in 49 CFR parts 15 and 1520, except with the written permission of the Administrator of the Transportation Security Administration or the Secretary of Transportation. Unauthorized release may result in civil penalty or other action. For U.S. government agencies, public disclosure is governed by 5 U.S.C. 552 and 49 CFR parts 15 and 1520.

ILLUMINATION	SIGN TYPE	SIGN FUNCTION	MOUNTING METHOD	GENERAL DESCRIPTION & USE
REFLECTIVE / DYNAMIC	5-IN.01	INFORMATIONAL	GROUND MOUNT	VEHICULAR - Roadside Level ID/Space Count Informational

GENERAL NOTES

- All final design, engineering, and amount/sizing of structural sign support elements, material types/thicknesses, dimensions, and attachment methods shall be performed and approved by a licensed engineer to meet or exceed all applicable local and national codes.
- Final engineering, dimensions, materials, and fabrication are the responsibility of the Fabricator to ensure the highest quality fit and finish for all components of the completed product. All final detailing and specifications to be provided by the Fabricator within their final approved fabrication-ready shop drawings.
- Wherever dissimilar metals are in contact, always separate contact surfaces prior to assembly or installation with the necessary protective coatings/gaskets/washers to prevent galvanic corrosion.
- Final fabrication methods, quality and fit/finish to be reviewed and approved by DFW Airport Planning Department and wayfinding/architecture Design Consultants thru prototype reviews prior to final production run/installation processes (see Performance Specifications for details).
- Colors shown are for reference only, and are subject to the limitations of the printing process and/or variance of electronic RGB screen displays. Refer to color system swatches and/or final finish samples for accurate reference.
- Messages shown here are general placeholders only. See graphic message schedules for specific messaging by location and sign type.

FABRICATION INTENT NOTES

- F1** SIGN CABINET/FRAME: modular fabricated internal illuminated edge-lit sign module cabinet constructed of extruded aluminum and cast aluminum components with concealed internal welds; removable sign face and light modules; fabricated aluminum support frame with welded mitered corners and slotted mounting holes to accept sign mounting brackets; fabricated aluminum sign mounting frame with tapered side end cover panels, attached with aluminum pin and clip system; power feed/units hidden behind mounting frame with access holes in back for wall mounting; powdercoat all exposed surfaces of sign cabinet/support frame/mounting frame to match P1, satin finish
- F2** SIGN FACE: fabricated sign face assembly module constructed of extruded aluminum frame and concealed internal welds; faces are 3/16" white acrylic with 1st surface applied V1 vinyl film, graphics reversed out of blue (white is exposed white acrylic cut-thru blue film); faces illuminated with light panel assembly using LED edge-lit clear inscribed acrylic diffuser and self-contained technology (including electronics, extruded frame and diffuser)
- F3** TRIM: .080 fabricated aluminum trim piece with closed ends; detachable and mounted with keyholes/studs and set screws; paint all exposed surfaces to match P2, satin finish
- F4** MOUNTING: mount to wall structural elements with connection system as installation location conditions require (Fabricator to coordinate connection location/type of structural elements with General Contractor); paint all exposed surfaces to match P1, satin finish

GRAPHICS / COLORS / DECORATION NOTES

- L1** Typeface: font = ClearviewText Medium
- L2** Typeface: font = ClearviewText Bold
- L3** BRAILLE: Grade 2 contracted Braille; must meet all applicable ADA/TAS requirements for tactile signage
- S1** Universal Symbols: AIGA style symbol artwork
- S2** Arrow(s): use only official DFW wayfinding arrow artwork
- VINYL (FILM):
 - V1** Blue: 3M EC 7725-37 Sapphire Blue
 - V2** White: 3M 7725-20 Opaque Matte White
 - V3** Skylink Yellow: 3M 7725-114 Enamel Receptive
 - V4** Exit Light Green: 3M Opaque Matte to match PMS 368C
 - V5** Black: 3M 7725-22 Opaque Matte Black
 - V6** Safety Red: 3M Opaque Matte to match PMS 485C
- PAINT:
 - P1** Blue: Powder coated to match 3M EC 7725-37, satin finish
 - P2** Silver: MAP paint # MP30136, satin finish
 - P3** Skylink Yellow: MAP paint to match PMS 130C, satin finish
 - P4** White: MAP paint # MP05317; photopolymer Braille, satin fin.
 - P5** Light Green: MAP Paint to match PMS 368C, satin finish

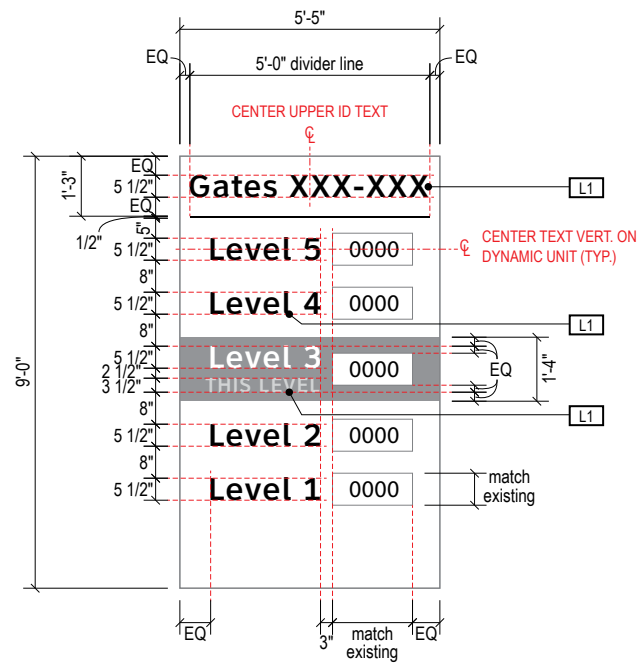

A FACE LAYOUT
Scale: 1/4" = 1'-0"

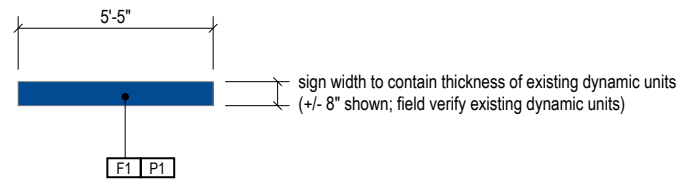

1 PLAN VIEW
Scale: 3/16" = 1'-0"



1 ELEVATION: Garage Level 3 Entrance Area (Typical)
Scale: 3/16" = 1'-0"

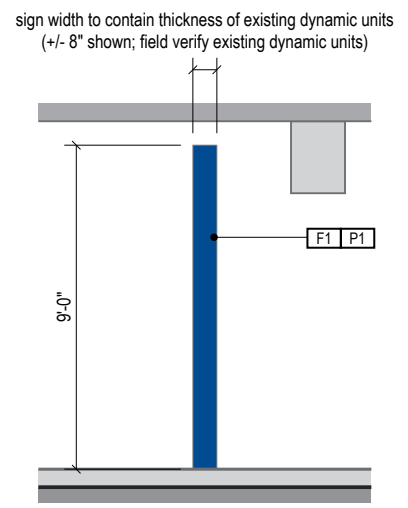

2 SIDE VIEW
Scale: 3/16" = 1'-0"

ILLUMINATION	SIGN TYPE	SIGN FUNCTION	MOUNTING METHOD	GENERAL DESCRIPTION & USE
NON-ILLUMINATED	5-RG.01	REGULATORY	BEAM	VEHICULAR - Do Not Enter Graphics

GENERAL NOTES

- All final design, engineering, and amount/sizing of structural sign support elements, material types/thicknesses, dimensions, and attachment methods shall be performed and approved by a licensed engineer to meet or exceed all applicable local and national codes.
- Final engineering, dimensions, materials, and fabrication are the responsibility of the Fabricator to ensure the highest quality fit and finish for all components of the completed product. All final detailing and specifications to be provided by the Fabricator within their final approved fabrication-ready shop drawings.
- Wherever dissimilar metals are in contact, always separate contact surfaces prior to assembly or installation with the necessary protective coatings/gaskets/washers to prevent galvanic corrosion.
- Final fabrication methods, quality and fit/finish to be reviewed and approved by DFW Planning Department and wayfinding/architecture Design Consultants thru prototype reviews prior to final production run/installation processes (see Performance Specifications for details).
- Colors shown are for reference only, and are subject to the limitations of the printing process and/or variance of electronic RGB screen displays. Refer to color system swatches and/or final finish samples for accurate reference.
- Messages shown here are general placeholders only. See graphic message schedules for specific messaging by location and sign type.

FABRICATION INTENT NOTES

- F1** BACKGROUND AREA: paint existing background area with MAP paint, satin finish; field verify existing background surface area conditions and prep with primer prior to painting per paint manufacturer's specifications
- F2** LARGE LETTERS/SYMBOLS: paint letters/symbols with MAP paint, satin finish; field verify existing background surface area conditions and prep with primer prior to painting per paint manufacturer's specifications

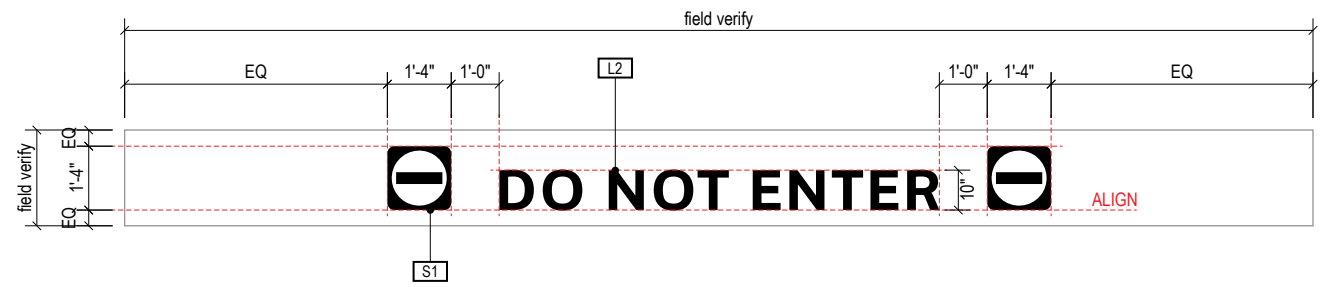

A FACE LAYOUT
Scale: 1/4" = 1'-0"

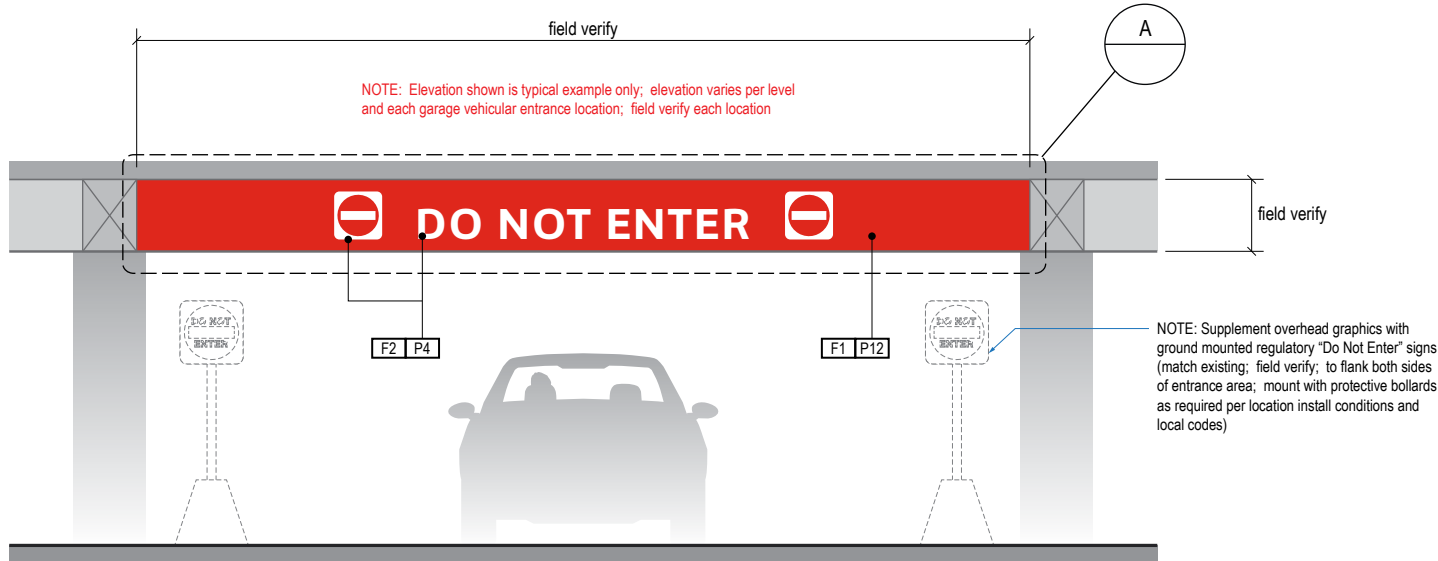

1 ELEVATION: Garage Entrance Area (Typical)
Scale: 3/16" = 1'-0"

GRAPHICS / COLORS / DECORATION NOTES

- L2** Typeface: ClearviewText Bold
- PAINT:**
- P4** White: MAP paint # MP05317, satin fin.
- P12** Safety Red: MAP paint to match PMS 485C, satin fin.

ILLUMINATION	SIGN TYPE	SIGN FUNCTION	MOUNTING METHOD	GENERAL DESCRIPTION & USE
REFLECTIVE / DYNAMIC	5-IN.02	INFORMATIONAL	GROUND MOUNT	VEHICULAR - Roadside Level ID/Space Count Informational

GENERAL NOTES

- All final design, engineering, and amount/sizing of structural sign support elements, material types/thicknesses, dimensions, and attachment methods shall be performed and approved by a licensed engineer to meet or exceed all applicable local and national codes.
- Final engineering, dimensions, materials, and fabrication are the responsibility of the Fabricator to ensure the highest quality fit and finish for all components of the completed product. All final detailing and specifications to be provided by the Fabricator within their final approved fabrication-ready shop drawings.
- Wherever dissimilar metals are in contact, always separate contact surfaces prior to assembly or installation with the necessary protective coatings/gaskets/washers to prevent galvanic corrosion.
- Final fabrication methods, quality and fit/finish to be reviewed and approved by DFW Airport Planning Department and wayfinding/architecture Design Consultants thru prototype reviews prior to final production run/installation processes (see Performance Specifications for details).
- Colors shown are for reference only, and are subject to the limitations of the printing process and/or variance of electronic RGB screen displays. Refer to color system swatches and/or final finish samples for accurate reference.
- Messages shown here are general placeholders only. See graphic message schedules for specific messaging by location and sign type.

FABRICATION INTENT NOTES

- F1** SIGN FACE PANELS: 1/4" thick aluminum sign face panels; mechanically fasten sign panels to support tube structure with stainless steel tamper-proof screws, paint heads to match sign face; digitally printed full-bleed color graphics on 3M Reflective DG3 4090 White film applied to 1st surface of face panels; all exposed surfaces, returns, etc to be painted with MAP paint to match P1, satin finish; routed cut-outs in face panels and vents in sign box sized per dynamic unit required
- F2** SUPPORT FRAME/POST ATTACHMENT: fabricated 1" square aluminum support tube frame structure; all exposed support frame tube ends to be capped with aluminum; all welds on frame/caps to be filled and ground smooth for uniform appearance; support frame mechanically attached to support post as required w/ mech. fasteners (fabricator to field verify); support frame to be painted all exposed surfaces with MAP paint to match P2, satin finish
- F3** SUPPORT POST: Fabricated square aluminum vertical support post tube; support post tube end to be capped with aluminum; all welds on frame/caps to be filled and ground smooth for uniform appearance; support post welded to foot plate and mechanically attached to concrete bollard; all support post/attachment plate/fasteners and exposed surfaces to be painted with MAP paint to match P2, satin finish

- F4** DYNAMIC SPACE COUNT UNIT: By others

GRAPHICS / COLORS / DECORATION NOTES

- L1** Typeface: font = ClearviewText Medium
- L2** Typeface: font = ClearviewText Bold
- S1** Universal Symbols: AIGA style symbol artwork
- S2** Arrow(s): use only official DFW wayfinding arrow artwork

- VINYL (FILM):**
- V4** Light Green: match PMS 368C
 - V7** White: 3M 4090 DG3 White (Reflective)
 - V9** Blue: 3M 4095 DG3 Blue (Reflective)
 - IB1** Black reflective vinyl (7803)
 - IB2** Powder coated Traffic Yellow

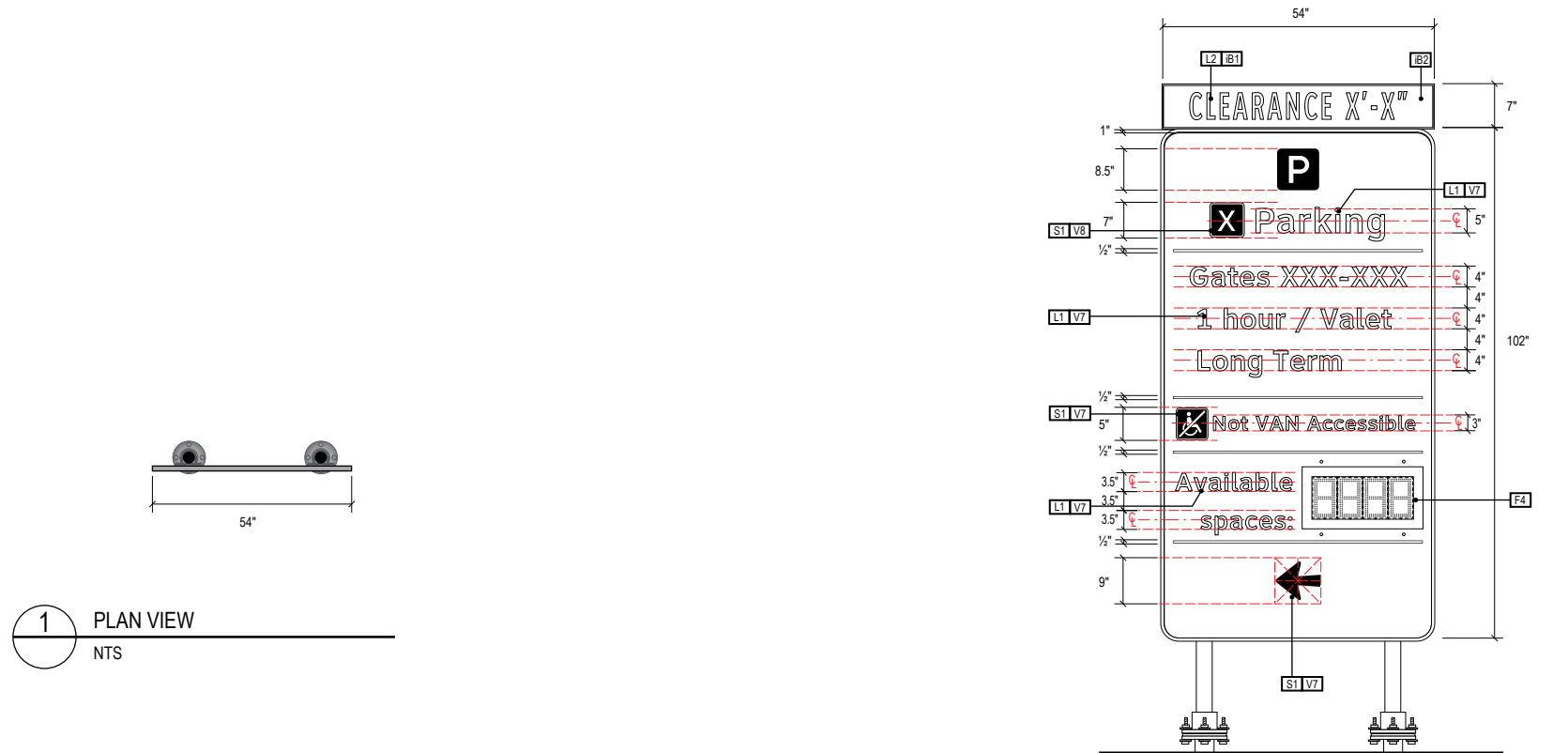

1 PLAN VIEW
NTS

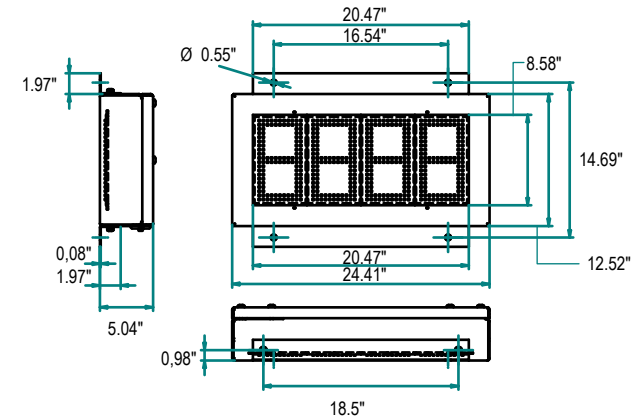

A FACE LAYOUT Digital Component
NTS

A FACE LAYOUT
NTS

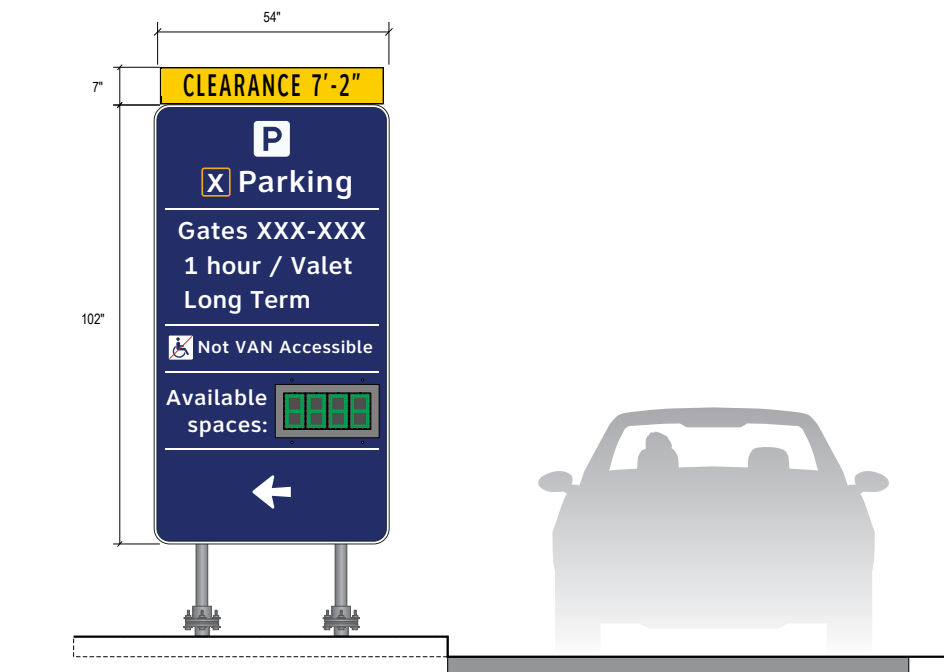

1 ELEVATION: Garage Entrance Area (Typical)
NTS

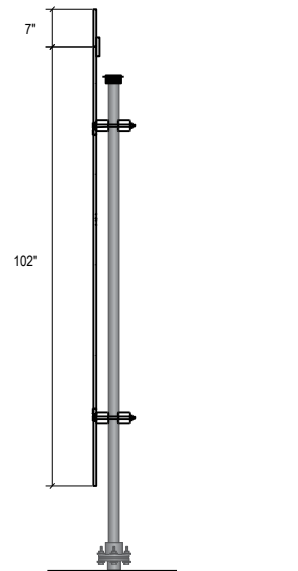

2 SIDE VIEW
NTS

WARNING:

This record contains Sensitive Security Information that is controlled under 49 CFR parts 15 and 1520. No part of this record may be disclosed to persons with a "need to know," as defined in 49 CFR parts 15 and 1520, except with the written permission of the Administrator of the Transportation Security Administration or the Secretary of Transportation. Unauthorized release may result in civil penalty or other action. For U.S. government agencies, public disclosure is governed by 5 U.S.C. 552 and 49 CFR parts 15 and 1520.

ILLUMINATION	SIGN TYPE	SIGN FUNCTION	MOUNTING METHOD	GENERAL DESCRIPTION & USE
REFLECTIVE	5-IN.03	INFORMATIONAL	GROUND MOUNT	VEHICULAR - Roadside Level ID/Space Count Informational

GENERAL NOTES

- All final design, engineering, and amount/sizing of structural sign support elements, material types/thicknesses, dimensions, and attachment methods shall be performed and approved by a licensed engineer to meet or exceed all applicable local and national codes.
- Final engineering, dimensions, materials, and fabrication are the responsibility of the Fabricator to ensure the highest quality fit and finish for all components of the completed product. All final detailing and specifications to be provided by the Fabricator within their final approved fabrication-ready shop drawings.
- Wherever dissimilar metals are in contact, always separate contact surfaces prior to assembly or installation with the necessary protective coatings/gaskets/washers to prevent galvanic corrosion.
- Final fabrication methods, quality and fit/finish to be reviewed and approved by DFW Airport Planning Department and wayfinding/architecture Design Consultants thru prototype reviews prior to final production run/installation processes (see Performance Specifications for details).
- Colors shown are for reference only, and are subject to the limitations of the printing process and/or variance of electronic RGB screen displays. Refer to color system swatches and/or final finish samples for accurate reference.
- Messages shown here are general placeholders only. See graphic message schedules for specific messaging by location and sign type.

FABRICATION INTENT NOTES

- F1** SIGN FACE PANELS: 1/4" thick aluminum sign face panels; mechanically fasten sign panels to support tube structure with stainless steel tamper-proof screws, paint heads to match sign face; digitally printed full-bleed color graphics on 3M Reflective DG3 4090 White film applied to 1st surface of face panels; all exposed surfaces, returns, etc to be painted with MAP paint to match P1, satin finish; routed cut-outs in face panels and vents in sign box sized per dynamic unit required
- F2** SUPPORT FRAME/POST ATTACHMENT: fabricated 1" square aluminum support tube frame structure; all exposed support frame tube ends to be capped with aluminum; all welds on frame/caps to be filled and ground smooth for uniform appearance; support frame mechanically attached to support post as required w/ mech. fasteners (fabricator to field verify); support frame to be painted all exposed surfaces with MAP paint to match P2, satin finish
- F3** SUPPORT POST: Fabricated square aluminum vertical support post tube; support post tube end to be capped with aluminum; all welds on frame/caps to be filled and ground smooth for uniform appearance; support post welded to foot plate and mechanically attached to concrete bollard; all support post/attachment plate/fasteners and exposed surfaces to be painted with MAP paint to match P2, satin finish

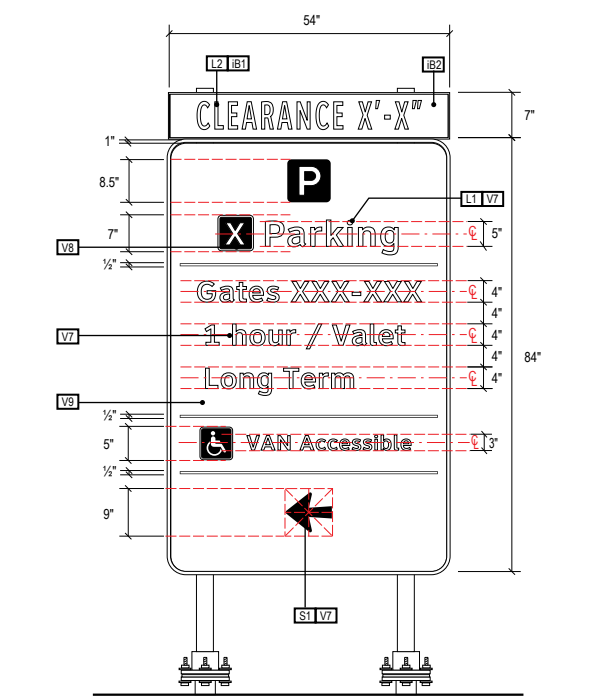
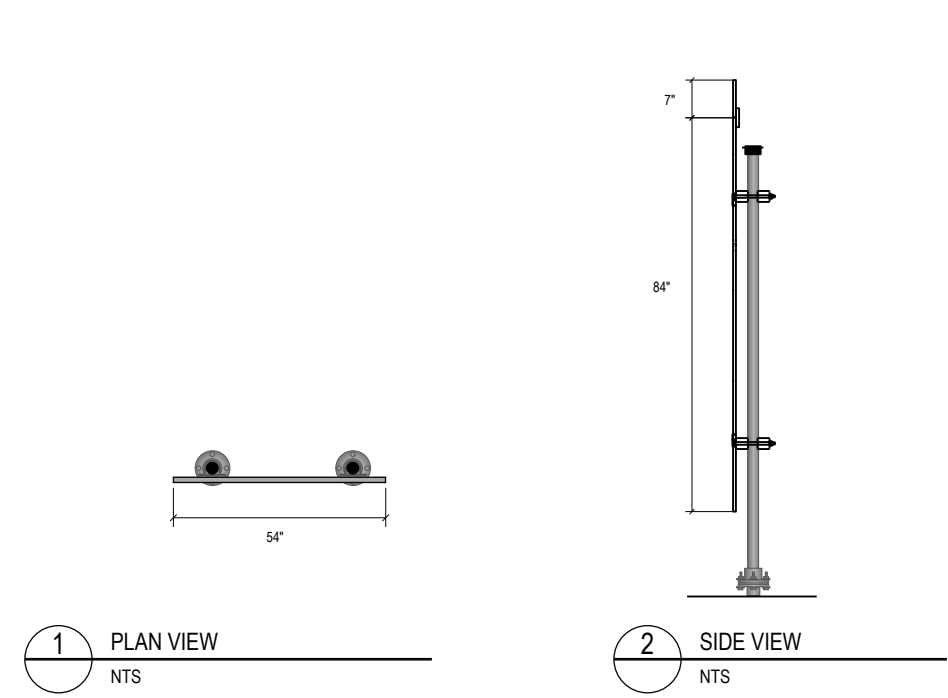

1 PLAN VIEW
NTS

2 SIDE VIEW
NTS

A FACE LAYOUT
NTS



1 ELEVATION: Garage Entrance Area (Typical)
NTS

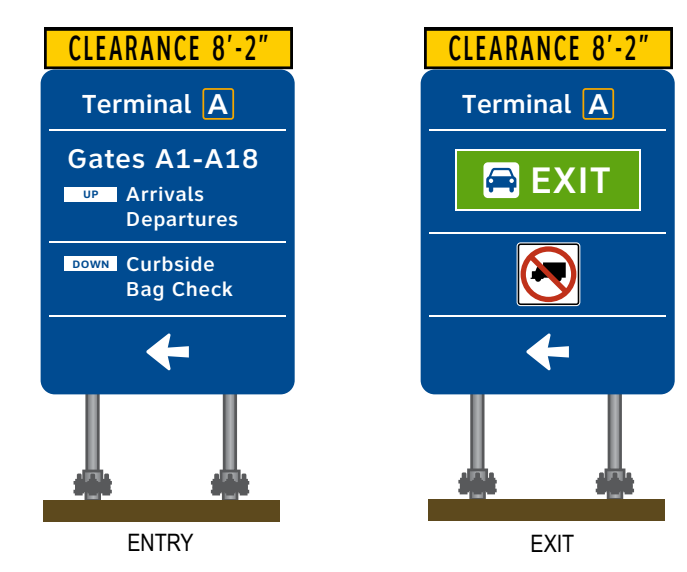

B Alternative Sign faces
NTS

GRAPHICS / COLORS / DECORATION NOTES

- L1** Typeface: font = ClearviewText Medium
- L2** Typeface: font = ClearviewText Bold
- S1** Universal Symbols: AIGA style symbol artwork
- S2** Arrow(s): use only official DFW wayfinding arrow artwork
- VINYL (FILM):**
- V4** Light Green: match PMS 368C
- V7** White: 3M 4090 DG3 White (Reflective)
- V9** Blue: 3M 4095 DG3 Blue (Reflective)
- IB1** Black reflective vinyl (7803)
- IB2** Powder coated Traffic Yellow

ILLUMINATION	SIGN TYPE	SIGN FUNCTION	MOUNTING METHOD	GENERAL DESCRIPTION & USE
NON-ILLUMINATED	5-ID.25	IDENTIFICATION	POLE MOUNT	VEHICULAR - Garage Totem Sign

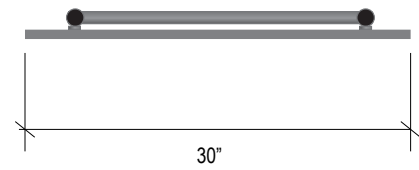

1 PLAN VIEW
Scale: NTS

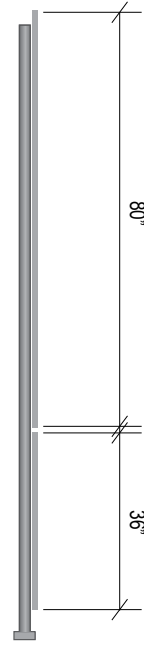

3 END VIEW
Scale: NTS

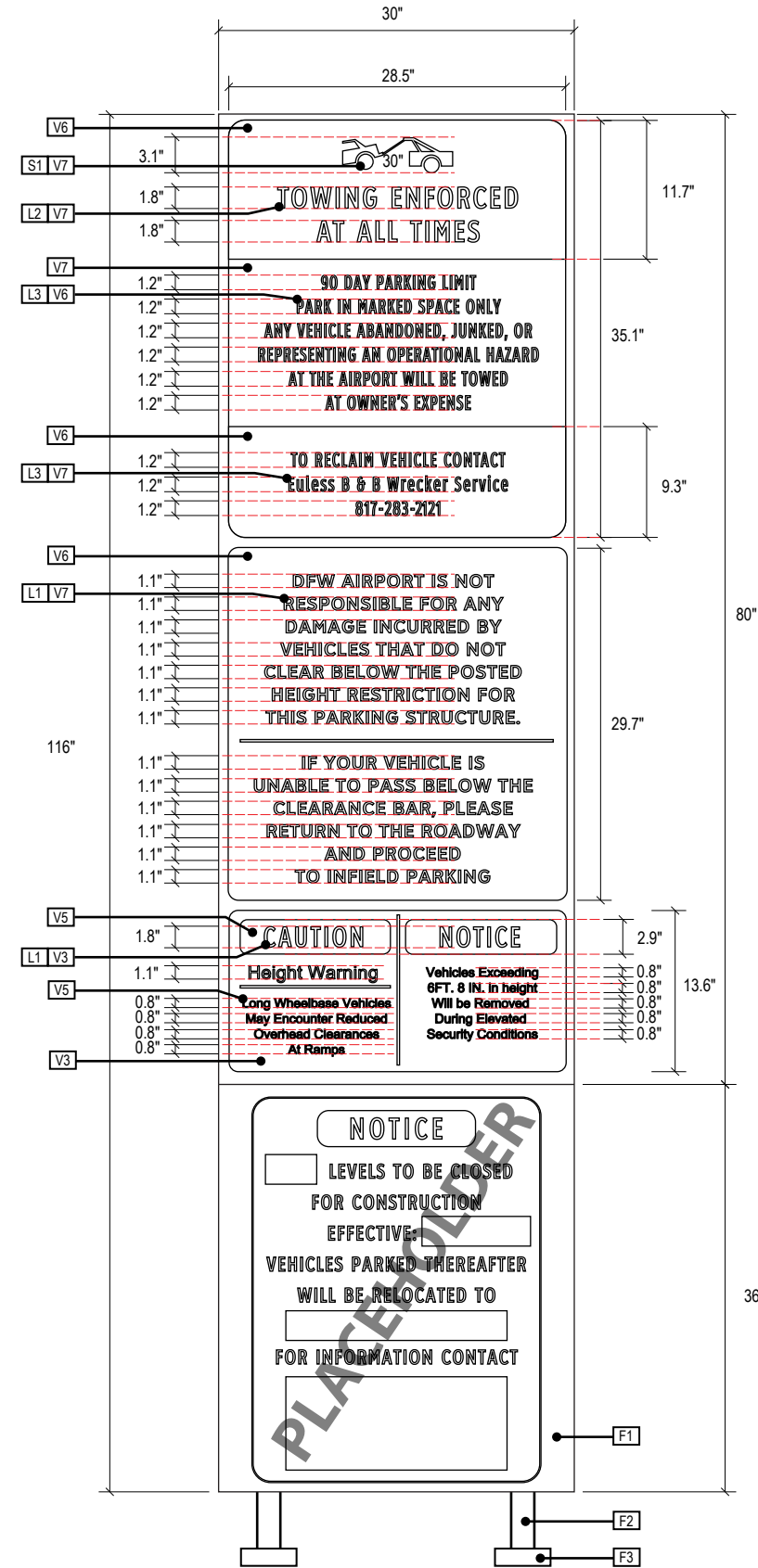

A FACE LAYOUT
Scale: NTS

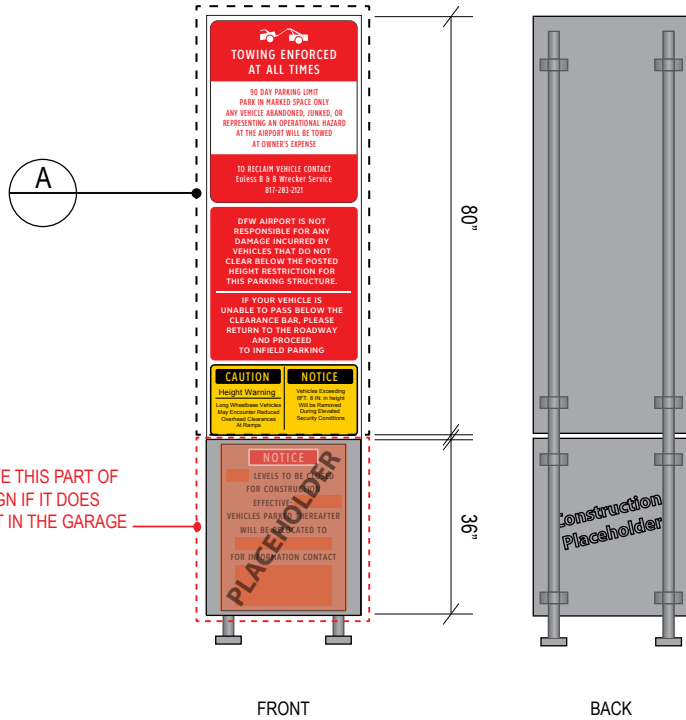

2 ELEVATION
Scale: NTS

GENERAL NOTES

- All final design, engineering, and amount/sizing of structural sign support elements, material types/thicknesses, dimensions, and attachment methods shall be performed and approved by a licensed engineer to meet or exceed all applicable local and national codes.
- Final engineering, dimensions, materials, and fabrication are the responsibility of the Fabricator to ensure the highest quality fit and finish for all components of the completed product. All final detailing and specifications to be provided by the Fabricator within their final approved fabrication-ready shop drawings.
- Wherever dissimilar metals are in contact, always separate contact surfaces prior to assembly or installation with the necessary protective coatings/gaskets/washers to prevent galvanic corrosion.
- Final fabrication methods, quality and fit/finish to be reviewed and approved by DFW Planning Department and wayfinding/architecture Design Consultants thru prototype reviews prior to final production run/installation processes (see Performance Specifications for details).
- Colors shown are for reference only, and are subject to the limitations of the printing process and/or variance of electronic RGB screen displays. Refer to color system swatches and/or final finish samples for accurate reference.
- Messages shown here are general placeholders only. See graphic message schedules for specific messaging by location and sign type.

FABRICATION INTENT NOTES

- F1 SIGN FACE PANELS: 1/4" thick aluminum sign face panels; digitally printed full-bleed color graphics on 3M Reflective DG3 4090 White film applied to 1st surface of face panels; all exposed surfaces and returns to be painted with MAP paint to match P1, satin finish
- F2 MOUNTING: mechanically fasten sign panels to wall/beam/soffit with stainless steel tamper-proof mechanical fasteners as install conditions require (Fabricator to field verify), paint heads to match sign face; NOTE: Fabricator to use proper connection gaskets/seals/etc to eliminate corrosion from mounting surface and weather conditions as install location conditions require (Fabricator to field verify)
- F3 TRIM: .080 fabricated aluminum trim piece with closed ends; detachable and mounted with keyholes/studs and set screws; paint all exposed surfaces to match P2, satin finish

GRAPHICS / COLORS / DECORATION NOTES

- L1 Typeface: font = ClearviewText Medium
 - L2 Typeface: font = ClearviewHwy 2-W
 - L3 Typeface: font = ClearviewHwy 1-W
 - S1 Universal Symbols: use only official DFW symbol artwork
- VINYL (FILM) :
- V3 Skylink Yellow: 3M 7725-114 Enamel Receptive
 - V5 Black: 3M 7725-22 Opaque Matte Black
 - V6 Safety Red: 3M Opaque Matte to match PMS 485C
 - V7 White: 3M 4090 DG3 White (Reflective)

7.0

7.0 TEMPORARY CONSTRUCTION SIGNAGE

- 7.1 Sign Type Index
- 7.2 Sign Types

SIGN TYPE INDEX

TEMPORARY SIGNAGE

This chapter provides specific information regarding the temporary wayfinding sign types applicable for use in the curbside/roadways, terminals and the garage areas during construction and closures only. It contains a general signage overview of temporary signage as well as more specific design/layouts/notes for each individual sign type.

On the following pages, the Sign Type shows simple views of each sign type, as well as listings for each sign type's name, mounting method and basic overall size.

Sign Types - Design Intent Drawings

Section 7.2- Sign Types contains design intent drawings of each specific temporary wayfinding sign type used within the Curbside/Roadways, Terminals and the Garage areas of DFW. Each sheet displays drawings of individual sign types and sizing/dimensions, face layouts and general design intent related notes.

NOTE: these documents are intended to illustrate design intent for temporary signage during construction and closures only, and should only be used as a general guideline. No information contained here should be construed as engineered elements. The designer/fabricator/contractor shall be responsible for all engineering and specifications with regard to structural, electrical, mechanical, foundation and installation. Details and information contained in this document shall not be reproduced, copied or utilized in any way except for the specific project for which they were created without previous written authorization from DFW.

Mounting Requirements

Sign mountings shall support signs for optimum visibility, facilitate illumination where required, be fabricated from commonly available materials, be easily maintained, be engineered to established DFW wayfinding system and engineering requirements, and not obstruct or pose any hazard to pedestrians, vehicles or any other entity.

Basic Mounting Types

The basic mounting types used for temporary signage are as follows:

- Stanchions Frames, Wall Mounted Sign, Vinyl Overlay over an existing signage
- Light Pole/Column Wrap - Signs that are mounted to existing light poles or columns with mechanical fastening systems and/or surface applied film

WARNING:

This record contains Sensitive Security Information that is controlled under 49 CFR parts 15 and 1520. No part of this record may be disclosed to persons with a "need to know," as defined in 49 CFR parts 15 and 1520, except with the written permission of the Administrator of the Transportation Security Administration or the Secretary of Transportation. Unauthorized release may result in civil penalty or other action. For U.S. government agencies, public disclosure is governed by 5 U.S.C. 552 and 49 CFR parts 15 and 1520.

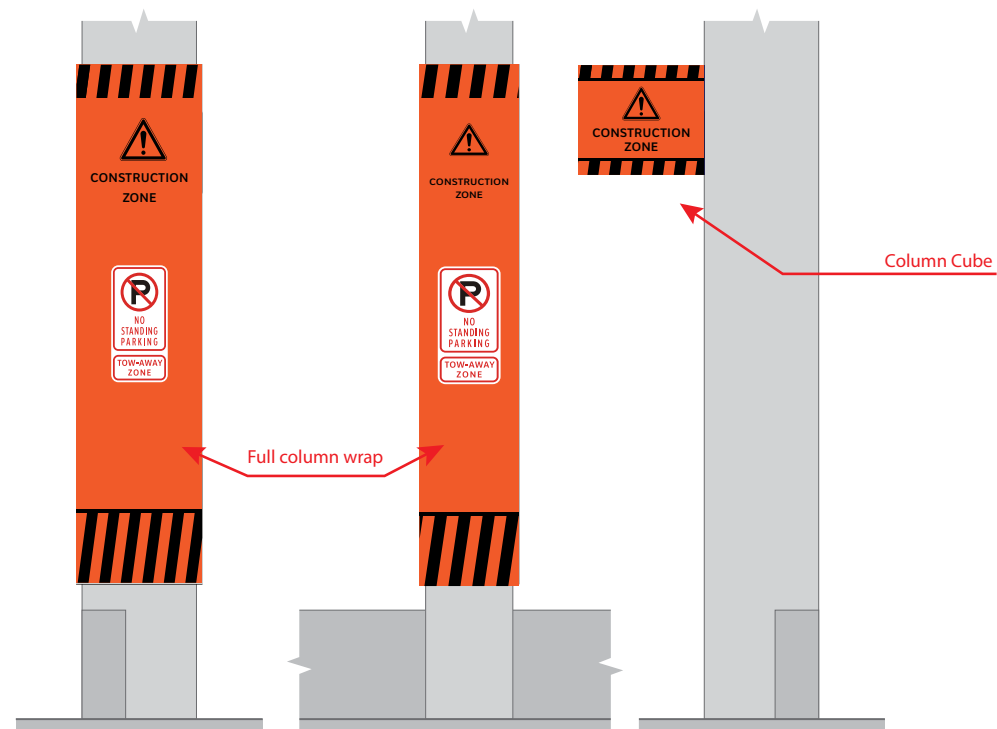

Curbside

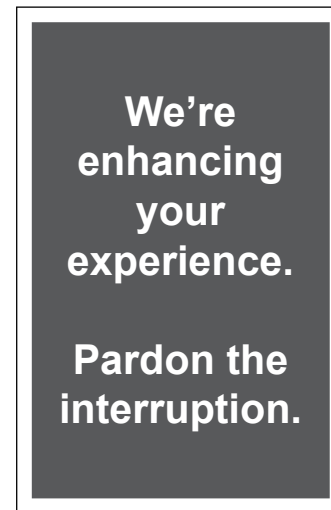

Tabloid 11" x 17"

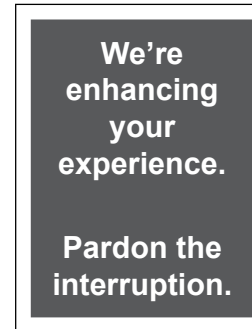

Letter 8" x 11"



Sidewalk Sign - Garage - Vehicle 28" x 44"



Door Sticker - Pedestrian 24" x 12"



Garage - Vehicle 22" x 15"

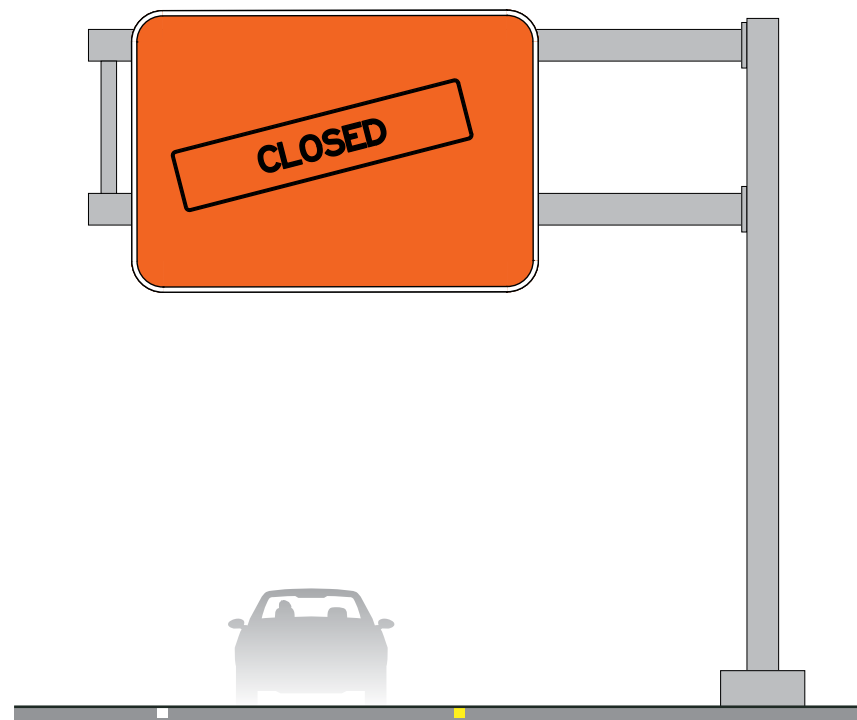

Roadways



Box 2' x 3'-4" x 2'



Sidewalk sign - Curbside - Pedestrian 24" x 36"

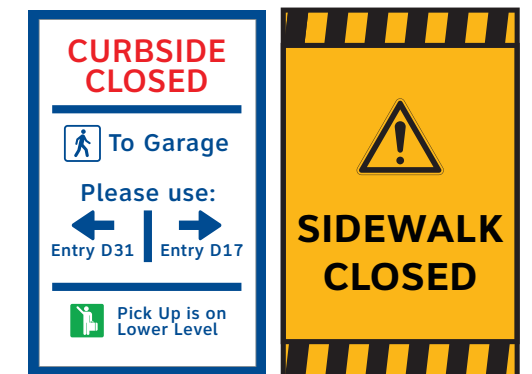

1 CURBSIDE / ROADWAY TEMPORARY SIGNAGE
NTS

2 TERMINAL TEMPORARY SIGNAGE
NTS

3 GARAGE TEMPORARY SIGNAGE
NTS

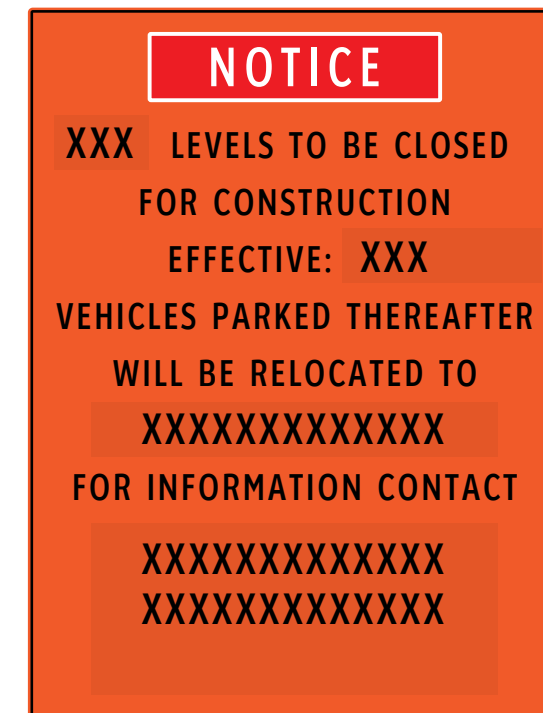
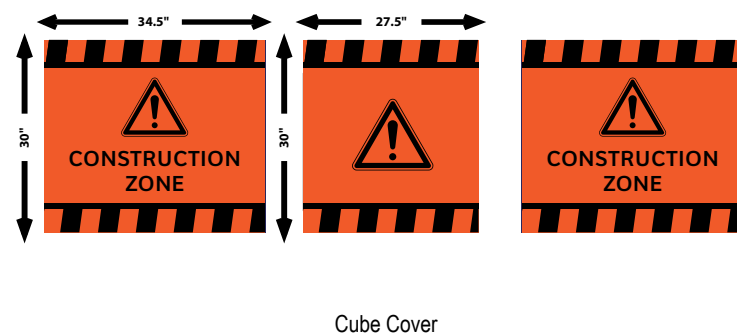
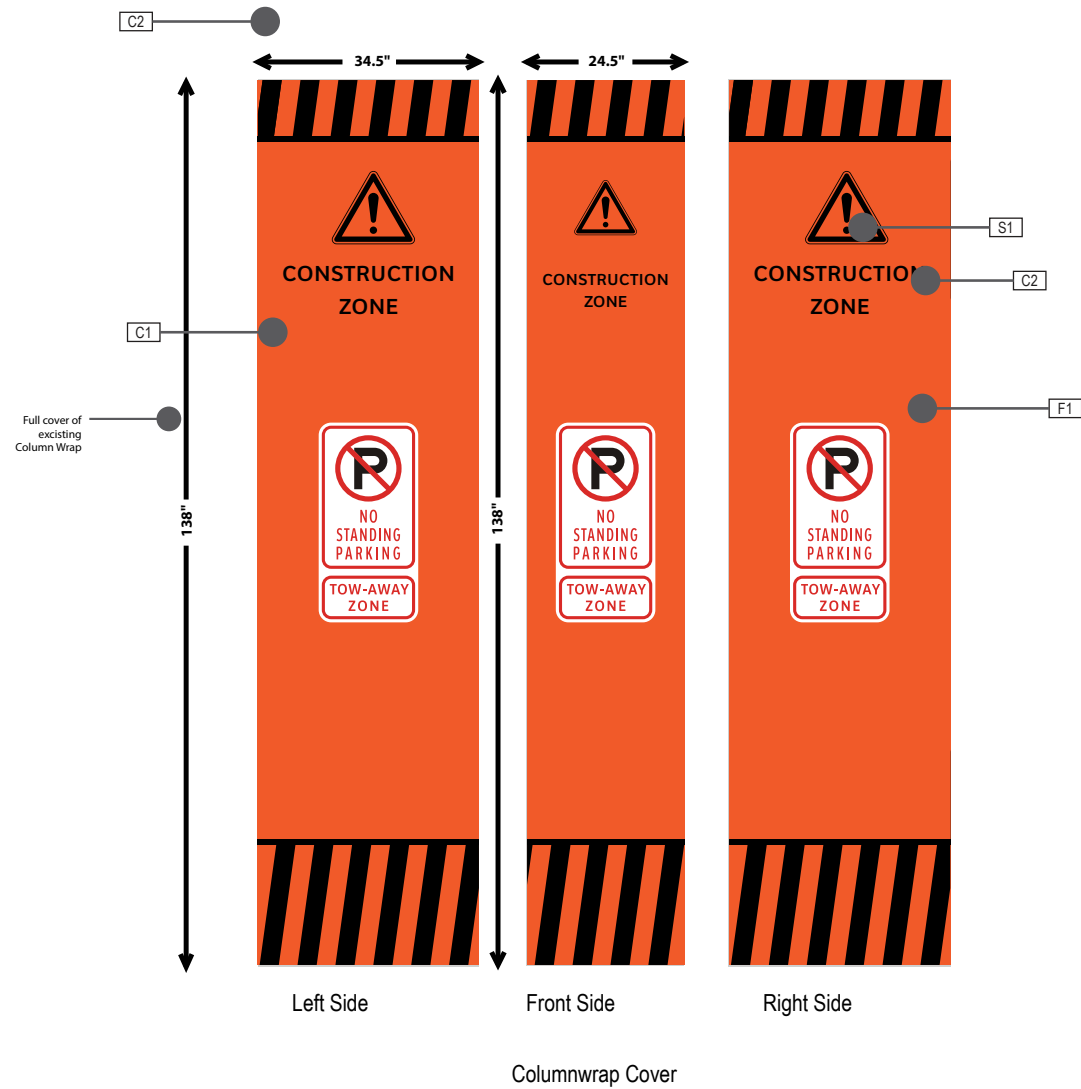
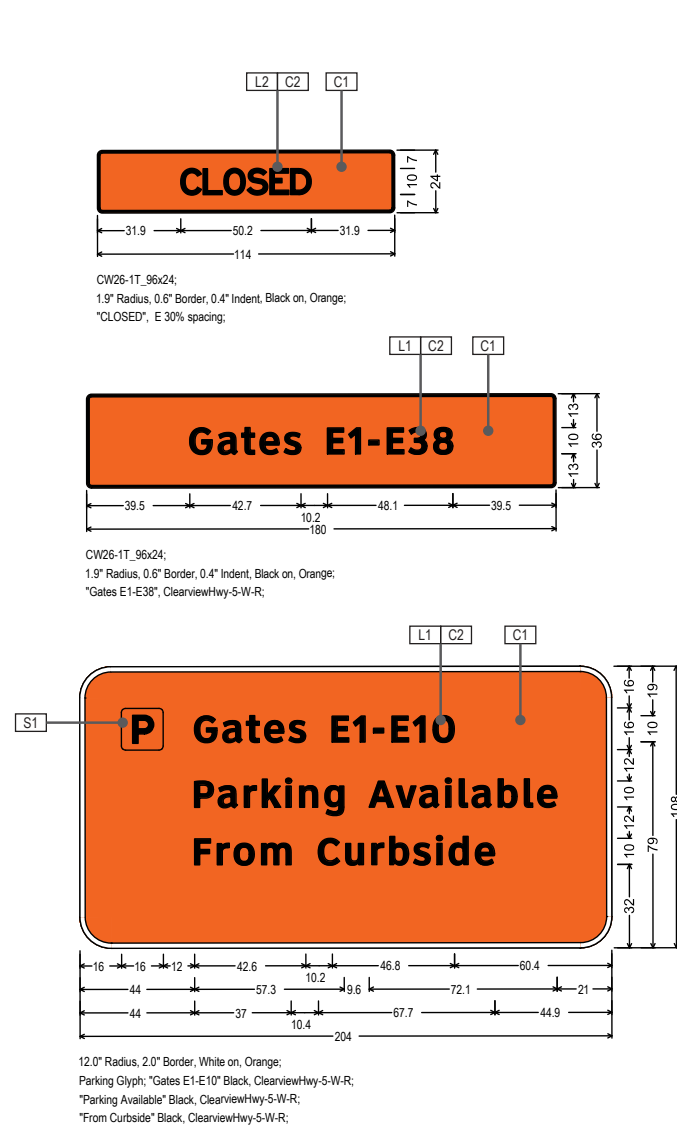

Media Size: 2'-6" X 3'-6"



Sidewalk Sign - Media Size: 24" x 36"

GENERAL NOTES

- Wherever dissimilar metals are in contact, always separate contact surfaces prior to assembly or installation with the necessary protective coatings/gaskets/washers to prevent galvanic corrosion.
- Colors shown are for reference only, and are subject to the limitations of the printing process and / or variance of electronic RGB screen displays. Refer to color system swatches and/or final finish samples for accurate reference.
- All dimensions are approximate, contractor to field verify for accuracy.
- Messages shown here are typical placeholders only.
- No additional payment will be made for variation in size.
- Any damage to existing signage due to temporary signage should be replaced at the contractor's expense at the conclusion of the project.
- Drawing is for sign location reference only. This is not an architectural document.

FABRICATION NOTES (GENERAL DESIGN INTENT)

- F1** SIGN PANEL: Digitally printed graphic on 180Cv3 cast vinyl film. The digital print shall be protected by 3M™ 8519 Scotchcal Luster Overlaminate clear UV protection film.

COLORS:

- C1** Orange: PMS P 152 C
- C2** Black: PMS Black C

TYPEFACES

- L1** Typeface: Clearview Text
- S1** Symbols: Use only official DFW Wayfinding symbol art

- N1** SIGN FACE PANELS: 1/4" thick aluminum sign face panels; digitally printed full-bleed color graphics on 3M Reflective DG3 4090 White film applied to 1st surface of face panels; all exposed surfaces and returns to be painted with MAP paint to match P1, satin finish

VINYL (FILM) / DIGITAL PRINT:

- V1** Safety Red: MAP paint to match PMS 485C, satin fin.
- V2** White: 3M HIP 3930 White (Reflective)

WARNING:

This record contains Sensitive Security Information that is controlled under 49 CFR parts 15 and 1520. No part of this record may be disclosed to persons with a "need to know," as defined in 49 CFR parts 15 and 1520, except with the written permission of the Administrator of the Transportation Security Administration or the Secretary of Transportation. Unauthorized release may result in civil penalty or other action. For U.S. government agencies, public disclosure is governed by 5 U.S.C. 552 and 49 CFR parts 15 and 1520.

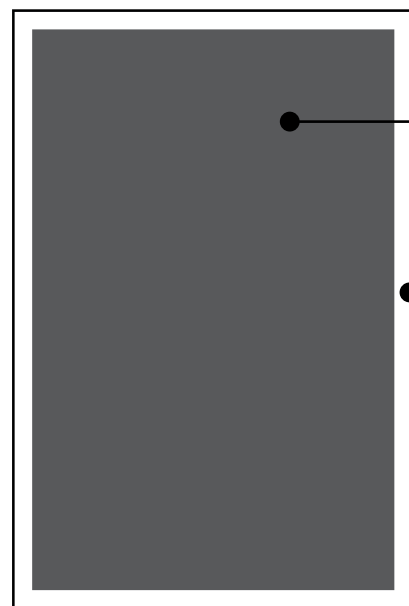

DFW Dark Gray
 Pantone Cool Gray 10 C
 CMYK: 0/0/0/80
 RGB: 88/88/88
 HEX: #585858

White band Size: 1/2"
 CMYK: 0/0/0/0
 RGB: 255/255/255
 HEX: #FFFFFF

Print Sizes*:

Tabloid 11"x17"
 Letter 8"x11"

* Can be printed by DFW print shop,
 DFW office/Department or Third party printer

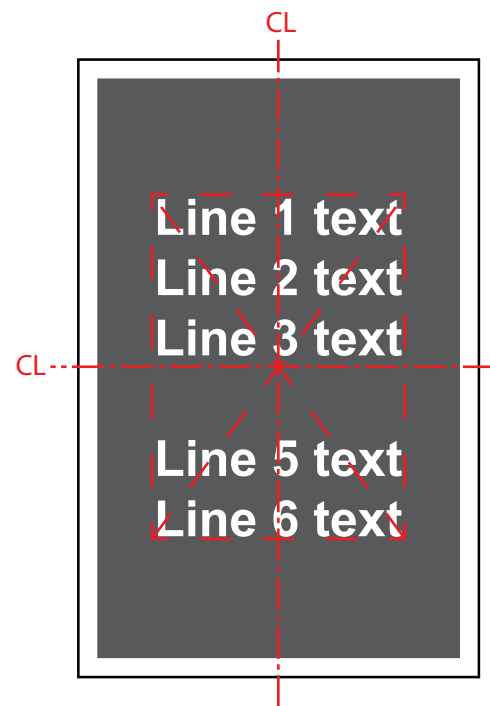

Message to be aligned on center line
 Both horizontal and vertical

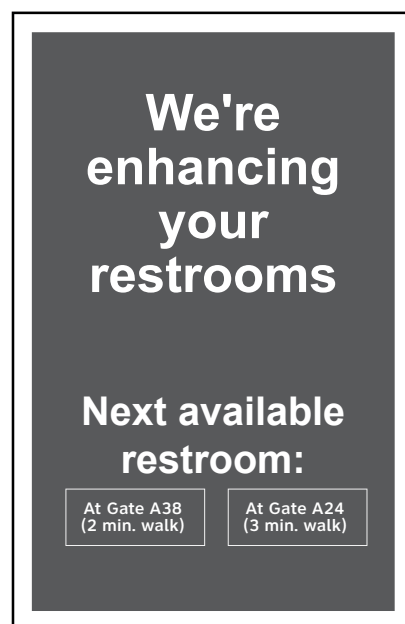

Short Version



Option A

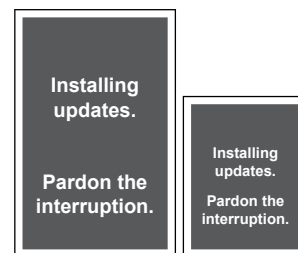

Option B



Option C

Long Version

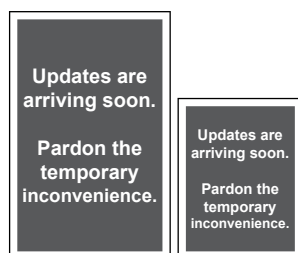

Option A

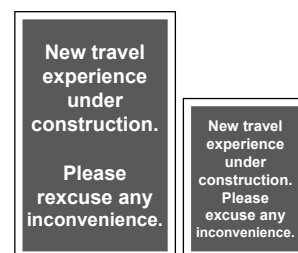

Option B

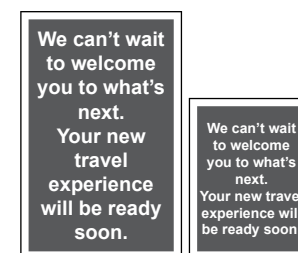

Option C

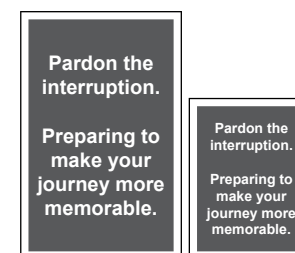

Option D

Generic

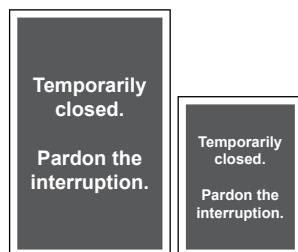

Option A

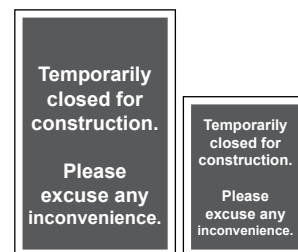

Option B



Option C

Box



Box 2'x3'-4"x2'

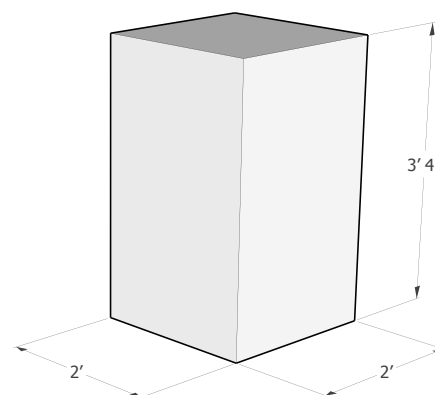

SIDES



TOP / BOTTOM

GENERAL NOTES

- Wherever dissimilar metals are in contact, always separate contact surfaces prior to assembly or installation with the necessary protective coatings/gaskets/washers to prevent galvanic corrosion.
- Colors shown are for reference only, and are subject to the limitations of the printing process and / or variance of electronic RGB screen displays. Refer to color system swatches and/or final finish samples for accurate reference.
- All dimensions are approximate, contractor to field verify for accuracy.
- Messages shown here are typical placeholders only.
- No additional payment will be made for variation in size.
- Any damage to existing signage due to temporary signage should be replaced at the contractors expense at the conclusion of the project.
- Drawing is for sign location reference only. This is not an architectural document.

FABRICATION NOTES (GENERAL DESIGN INTENT)

F1 SIGN PANEL: Digitally printed graphic on 180Cv3 cast vinyl film. The digital print shall be protected by 3M™ 8519 Scotchcal Luster Overlaminate clear UV protection film.

COLORS:

- C1** Orange: PMS P 152 C
- C2** Black: PMS Black C

TYPEFACES

- L1** Typeface: Clearview Text
- S1** Symbols: Use only official DFW Wayfinding symbol art

N1 SIGN FACE PANELS: 1/4" thick aluminum sign face panels; digitally printed full-bleed color graphics on 3M Reflective DG3 4090 White film applied to 1st surface of face panels; all exposed surfaces and returns to be painted with MAP paint to match P1, satin finish

VINYL (FILM) / DIGITAL PRINT:

- V1** Safety Red: MAP paint to match PMS 485C, satin fin.
- V2** White: 3M HIP 3930 White (Reflective)

WARNING:

This record contains Sensitive Security Information that is controlled under 49 CFR parts 15 and 1520. No part of this record may be disclosed to persons with a "need to know," as defined in 49 CFR parts 15 and 1520, except with the written permission of the Administrator of the Transportation Security Administration or the Secretary of Transportation. Unauthorized release may result in civil penalty or other action. For U.S. government agencies, public disclosure is governed by 5 U.S.C. 552 and 49 CFR parts 15 and 1520.

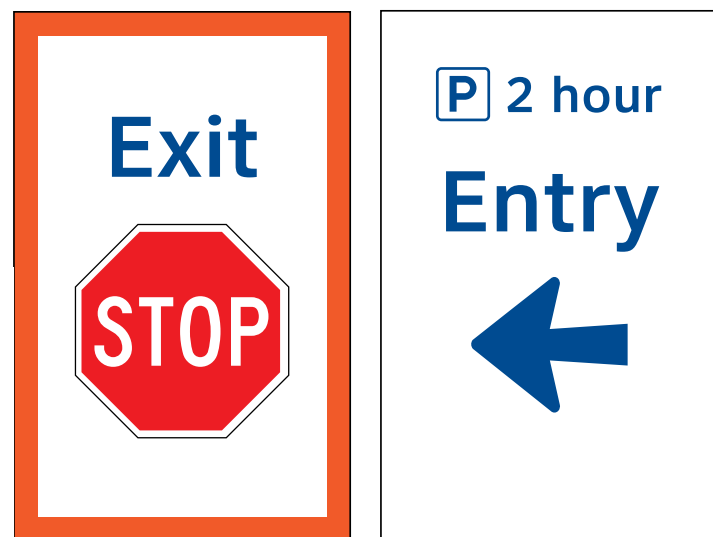
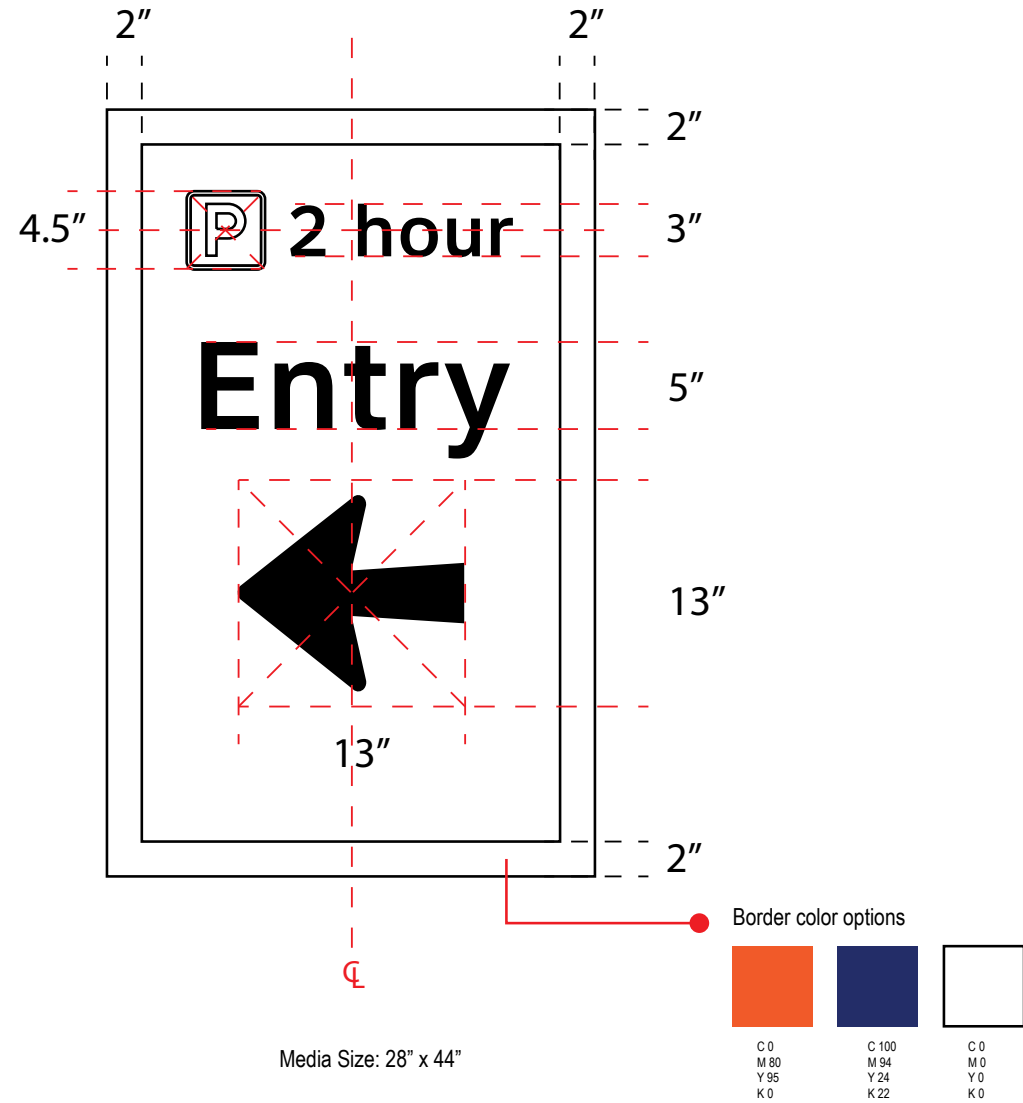

Garage - Vehicle 28" x 44"



Garage - Vehicle 30" x 60"

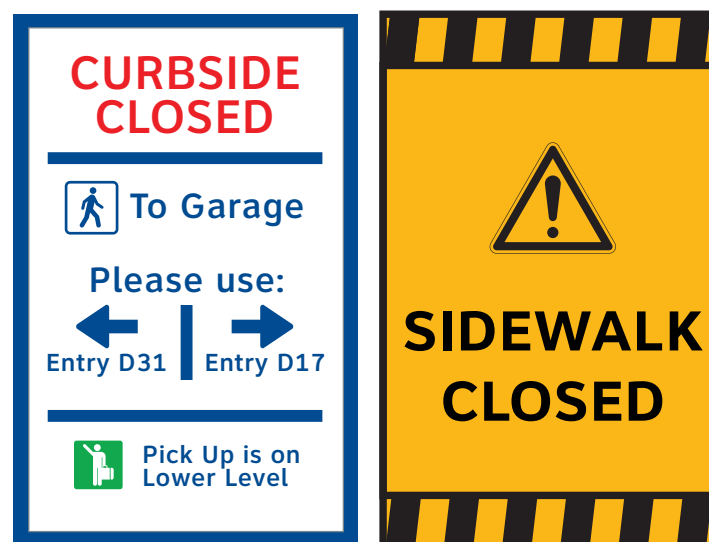

Curbside - Pedestrian 24" x 36"



Door Sticker - Pedestrian 24" x 12"

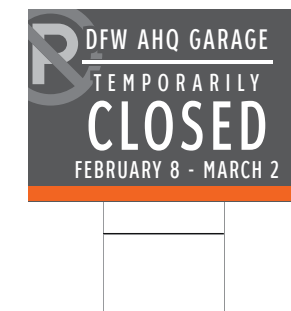

Garage - Vehicle 22" x 15"

GENERAL NOTES

- Wherever dissimilar metals are in contact, always separate contact surfaces prior to assembly or installation with the necessary protective coatings/gaskets/washers to prevent galvanic corrosion.
- Colors shown are for reference only, and are subject to the limitations of the printing process and / or variance of electronic RGB screen displays. Refer to color system swatches and/or final finish samples for accurate reference.
- All dimensions are approximate, contractor to field verify for accuracy.
- Messages shown here are typical placeholders only.
- No additional payment will be made for variation in size.
- Any damage to existing signage due to temporary signage should be replaced at the contractors expense at the conclusion of the project.
- Drawing is for sign location reference only. This is not an architectural document.

FABRICATION NOTES (GENERAL DESIGN INTENT)

F1 SIGN PANEL: Digitally printed graphic on 180Cv3 cast vinyl film. The digital print shall be protected by 3M™ 8519 Scotchcal Luster Overlaminate clear UV protection film.

COLORS:

- C1** Orange: PMS P 152 C
- C2** Black: PMS Black C

TYPEFACES

- L1** Typeface: Clearview Text
- S1** Symbols: Use only official DFW Wayfinding symbol art

N1 SIGN FACE PANELS: 1/4" thick aluminum sign face panels; digitally printed full-bleed color graphics on 3M Reflective DG3 4090 White film applied to 1st surface of face panels; all exposed surfaces and returns to be painted with MAP paint to match P1, satin finish

VINYL (FILM) / DIGITAL PRINT:

- V1** Safety Red: MAP paint to match PMS 485C, satin fin.
- V2** White: 3M HIP 3930 White (Reflective)

WARNING:

This record contains Sensitive Security Information that is controlled under 49 CFR parts 15 and 1520. No part of this record may be disclosed to persons with a "need to know," as defined in 49 CFR parts 15 and 1520, except with the written permission of the Administrator of the Transportation Security Administration or the Secretary of Transportation. Unauthorized release may result in civil penalty or other action. For U.S. government agencies, public disclosure is governed by 5 U.S.C. 552 and 49 CFR parts 15 and 1520.

8.0

8.0 COVID PANDEMIC PREPAREDNESS SIGNAGE

- 8.1 Sign Type Index
- 8.2 Sign Types

SIGN TYPE INDEX

COVID PANDEMIC PREPAREDNESS SIGNAGE

This chapter provides specific information regarding the awareness sign types applicable for use in the Terminals and Board Facilities for COVID Pandemic Awareness. It contains a general signage overview of iconography, color swatches, various signage type as well as more specific design/layouts/notes for a common used sign type.

Sign Types - Design Intent Drawings

Section 8.2 Sign Types contains basic guidelines of a typical covid awareness sign type used within the Terminals and Board Facilities of DFW. Each sheet displays drawings of individual sign types and sizing/dimensions, face layouts and general design intent related notes.

NOTE: these documents are intended to provide guidance for covid awareness signage and should only be used as a general guideline. No information contained here should be construed as engineered elements. The designer/fabricator/contractor shall be responsible for all engineering and specifications with regard to structural, electrical, mechanical, foundation and installation. Details and information contained in this document shall not be reproduced, copied or utilized in any way except for the specific project for which they were created without previous written authorization from DFW.

Mounting Requirements

Sign mountings shall support signs for optimum visibility, facilitate illumination where required, be fabricated from commonly available materials, be easily maintained, be engineered to established DFW wayfinding system and engineering requirements, and not obstruct or pose any hazard to pedestrians, vehicles or any other entity.

Basic Mounting Types

The basic mounting types used for temporary COVID Awareness signage are as follows:

- Stanchions Frames, Wall Mounted Sign, Vinyl Stickers

WARNING:

This record contains Sensitive Security Information that is controlled under 49 CFR parts 15 and 1520. No part of this record may be disclosed to persons with a "need to know," as defined in 49 CFR parts 15 and 1520, except with the written permission of the Administrator of the Transportation Security Administration or the Secretary of Transportation. Unauthorized release may result in civil penalty or other action. For U.S. government agencies, public disclosure is governed by 5 U.S.C. 552 and 49 CFR parts 15 and 1520.

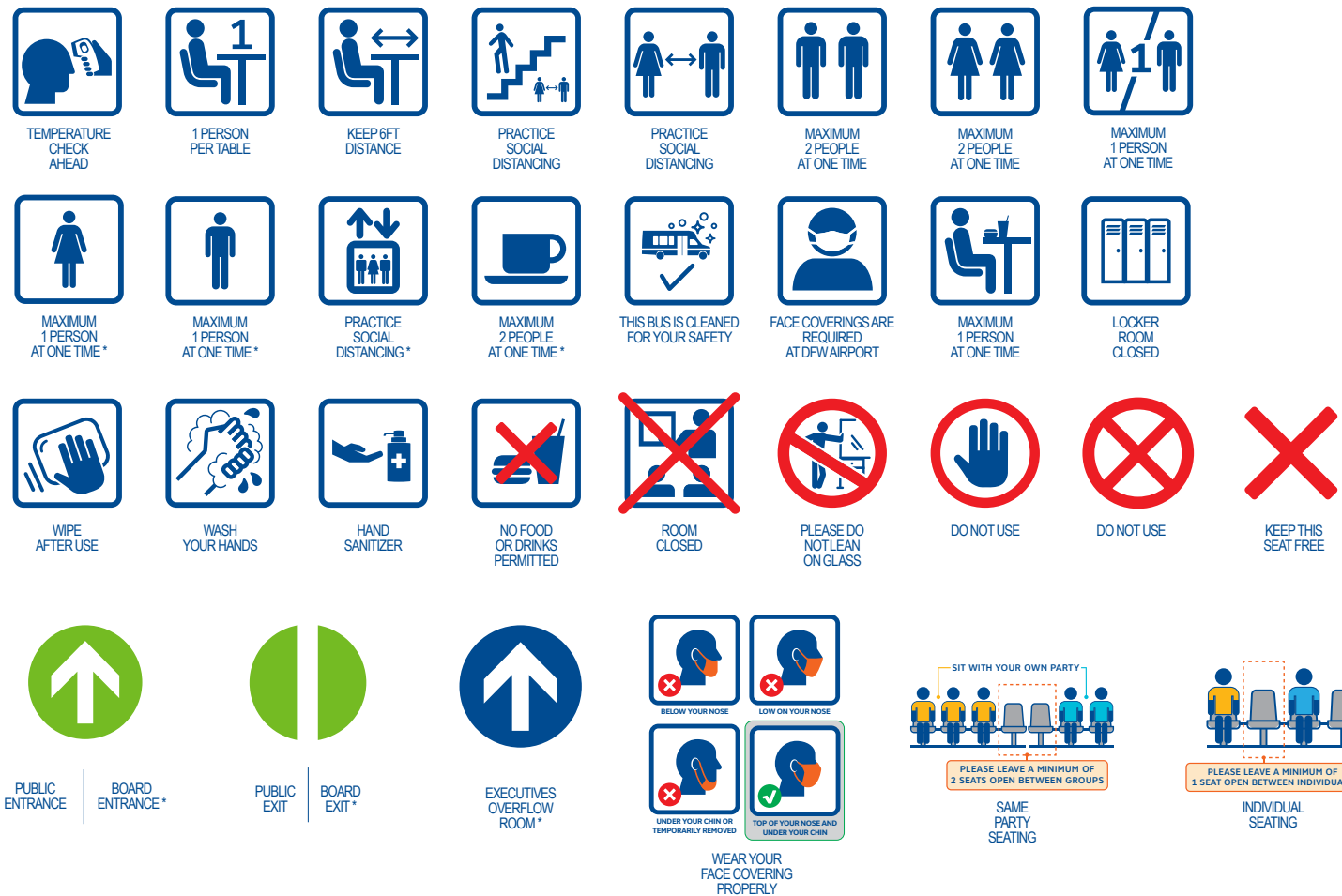

GROUNDWALL STICKERS



* ICONS ARE FORM DFW STANDARD ICONS

DFW COVID Color Swatches

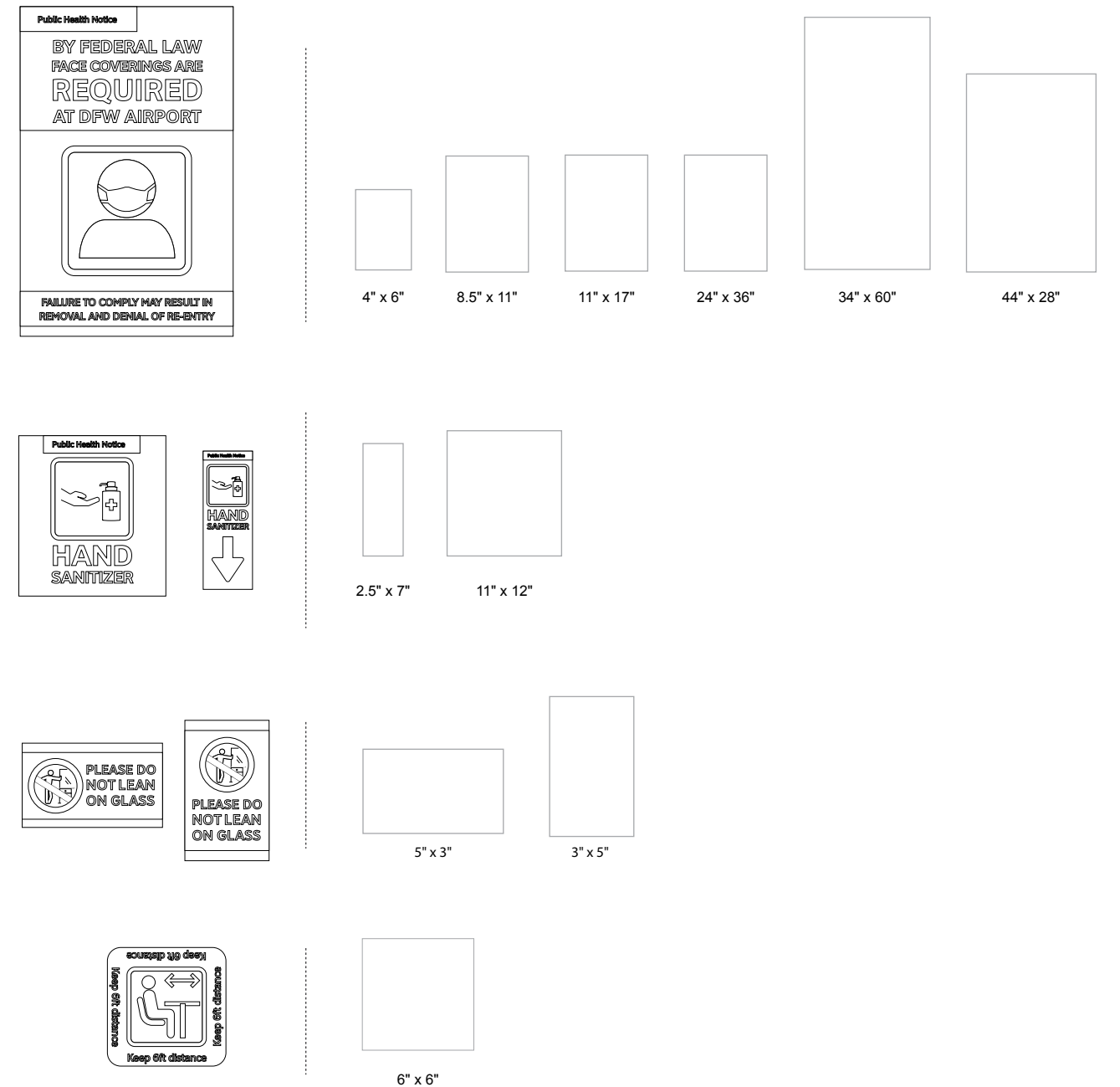
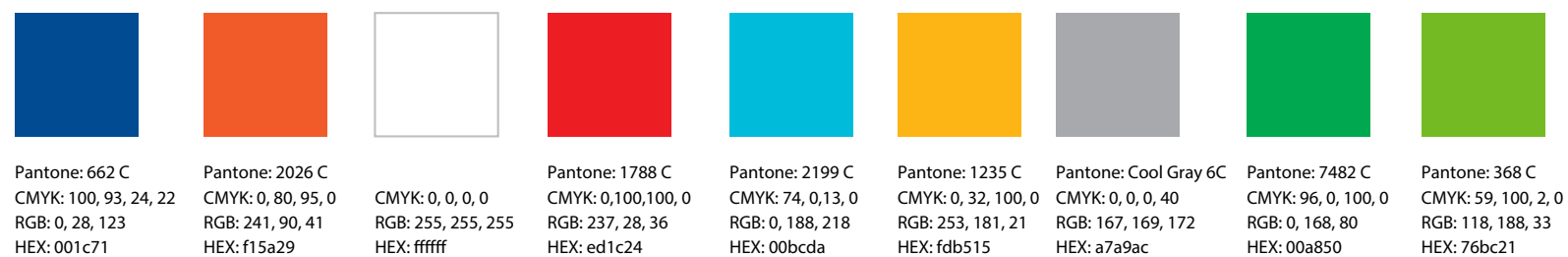

DFW COVID Ground/Wall Sticker Print Sizes

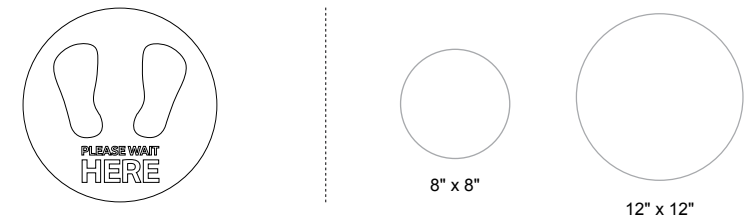

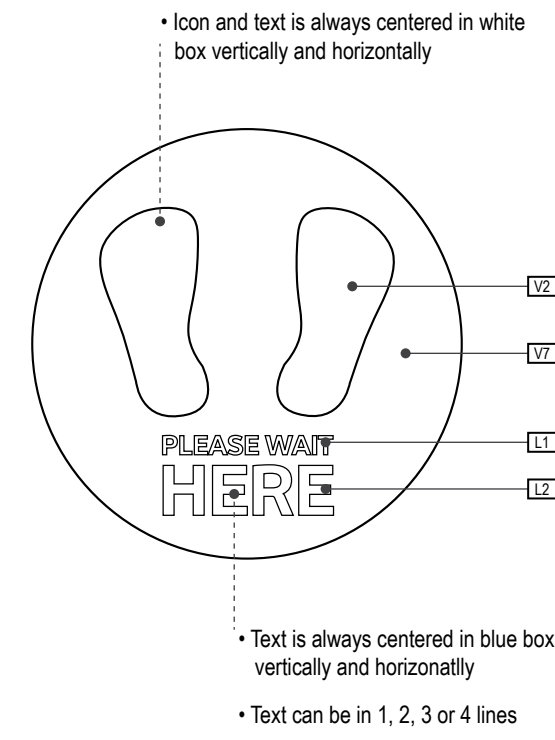
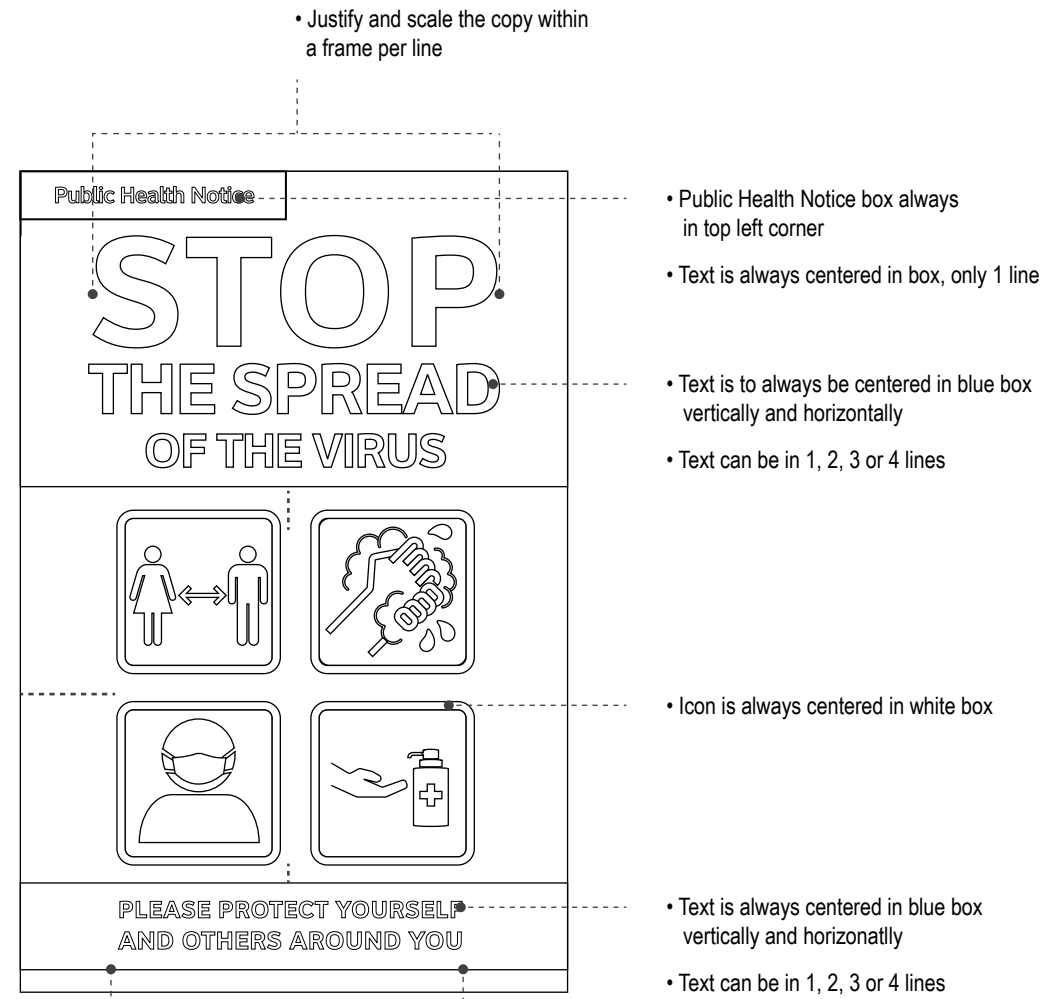
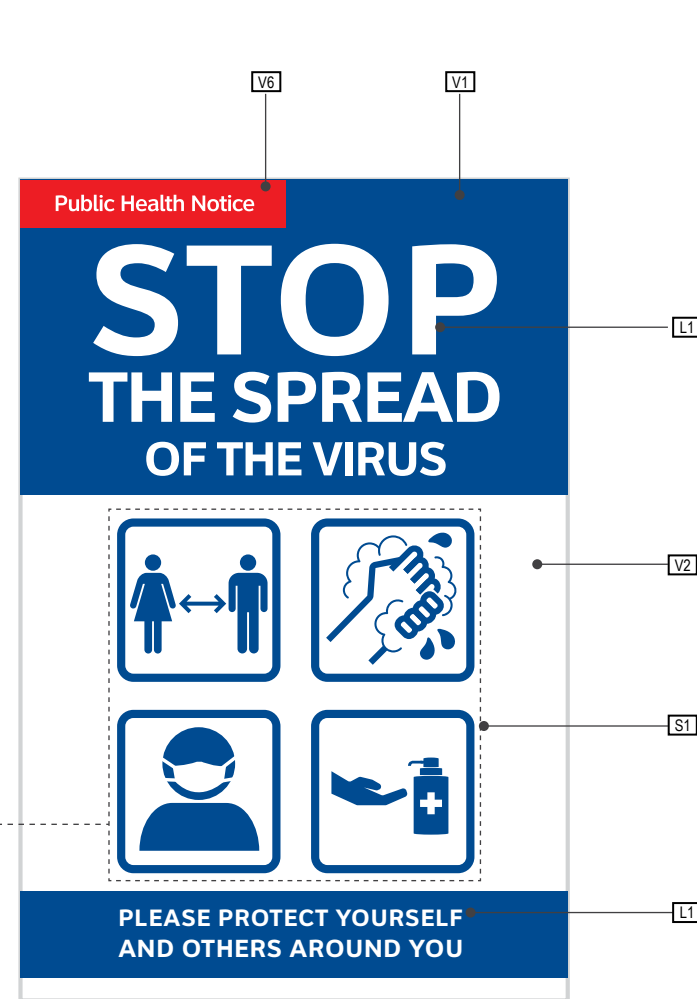

Alternate variations of icon layout within the sign shown below:



Justify and scale the copy within a frame per line

Standard text for COVID signage is always "PLEASE PROTECT YOURSELF AND OTHERS AROUND YOU"

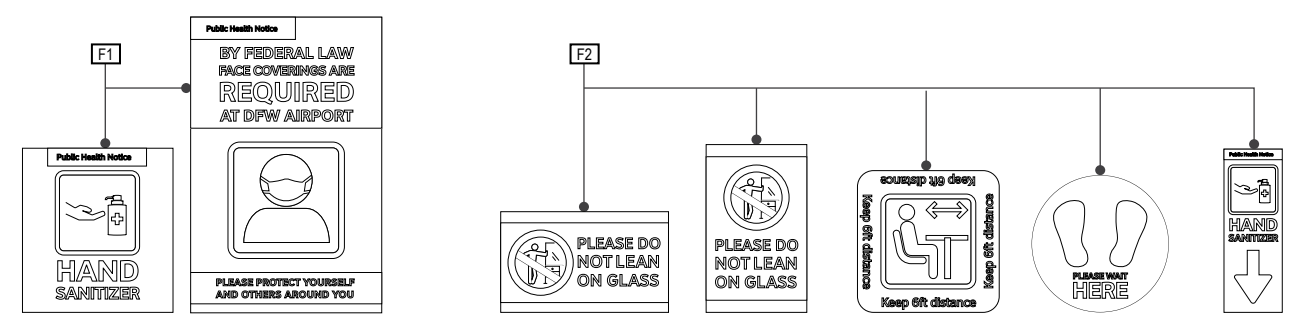

GENERAL NOTES

- All final design, engineering, and amount/sizing of structural sign support elements, material types/thicknesses, dimensions, and attachment methods shall be performed and approved by a licensed engineer to meet or exceed all applicable local and national codes.
- Final engineering, dimensions, materials, and fabrication are the responsibility of the Fabricator to ensure the highest quality fit and finish for all components of the completed product. All final detailing and specifications to be provided by the Fabricator within their final approved fabrication-ready shop drawings.
- Wherever dissimilar metals are in contact, always separate contact surfaces prior to installation with the necessary protective coatings/gaskets/washers to prevent galvanic corrosion.
- Final fabrication methods, quality and fit/finish to be reviewed and approved by DFW Airport Planning Department and wayfinding/architecture Design Consultants thru prototype reviews prior to final production run/installation processes (see Performance Specifications for details).
- Colors shown are for reference only, and are subject to the limitations of the printing process and/or variance of electronic RGB screen displays. Refer to color system swatches and/or final finish samples for accurate reference.
- Messages shown here are general placeholders only. See graphic message schedules for specific messaging by location and sign type.

FABRICATION INTENT NOTES

- F1** SIGN CABINET/FRAME: modular fabricated internal illuminated edge-lit sign module cabinet constructed of extruded aluminum and cast aluminum components with concealed internal welds; removable sign face and light modules; fabricated aluminum support frame with welded mitered corners and slotted mounting holes to accept sign mounting brackets; fabricated aluminum sign mounting frame with tapered side end cover panels, attached with aluminum pin and clip system; power feed/units hidden behind mounting frame with access holes in back for wall mounting; powdercoat all exposed surfaces of sign cabinet/support frame/mounting frame to match P1, satin finish
- F2** SIGN FACE: fabricated sign face assembly module constructed of extruded aluminum frame and concealed internal welds; faces are 3/16" white acrylic with 1st surface applied V1 vinyl film, graphics reversed out of blue (white is exposed white acrylic cut-thru blue film); faces illuminated with light panel assembly using LED edge-lit clear inscribed acrylic diffuser and self-contained technology (including electronics, extruded frame and diffuser)
- F3** TRIM: .080 fabricated aluminum trim piece with closed ends; detachable and mounted with keyholes/studs and set screws; paint all exposed surfaces to match P2, satin finish
- F4** MOUNTING: mount to wall structural elements with connection system as installation location conditions require (Fabricator to coordinate connection location/type of structural elements with General Contractor); paint all exposed surfaces to match P1, satin finish

GRAPHICS / COLORS / DECORATION NOTES

- L1** Typeface: font = ClearviewText Medium
- L2** Typeface: font = ClearviewText Bold
- L3** BRAILLE: Grade 2 contracted Braille; must meet all applicable ADA/TAS requirements for tactile signage
- S1** Universal Symbols: AIGA style symbol artwork
- S2** Arrow(s): use only official DFW wayfinding arrow artwork
- VINYL (FILM):**
- V1** Blue: 3M EC 7725-37 Sapphire Blue
- V2** White: 3M 7725-20 Opaque Matte White
- V3** Skylink Yellow: 3M 7725-114 Enamel Receptive
- V4** Exit Light Green: 3M Opaque Matte to match PMS 368C
- V5** Black: 3M 7725-22 Opaque Matte Black
- V6** Safety Red: 3M Opaque Matte to match PMS 485C
- V7** DFW Orange: 3M Opaque Matte to match PMS 2026C

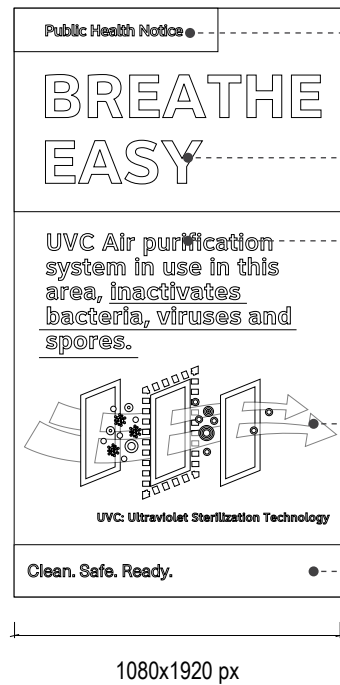
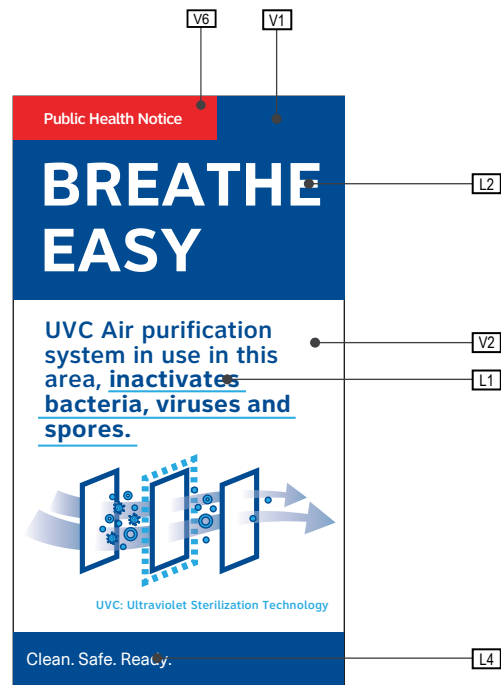

- Public Health Notice box always in top left corner
- Text is always centered in box, only 1 line
- Text is to always be centered in blue box vertically and horizontally and left aligned
- Text can be multiline and have highlights by underlining, using Bold fonts or different colors.
- Imagery is always centered in white box
- Text is to always be centered in blue box vertically and horizontally and left aligned
- Footer box should always be blue, never white

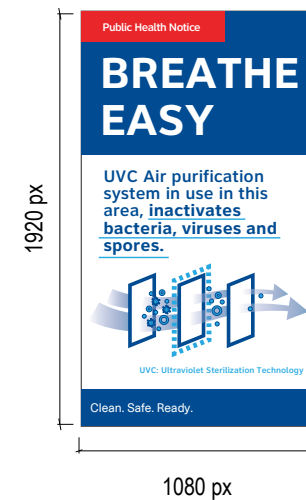
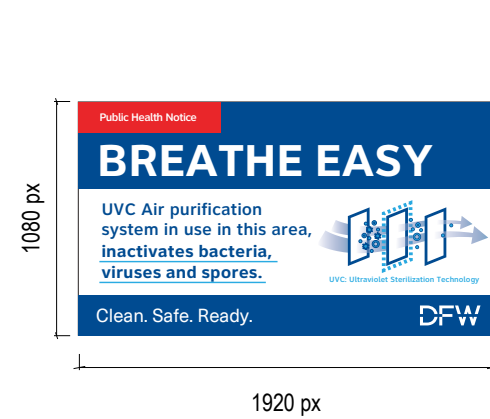

• Variations of UVC sign for horizontal and vertical layout shown above

DFW Cleaning Station

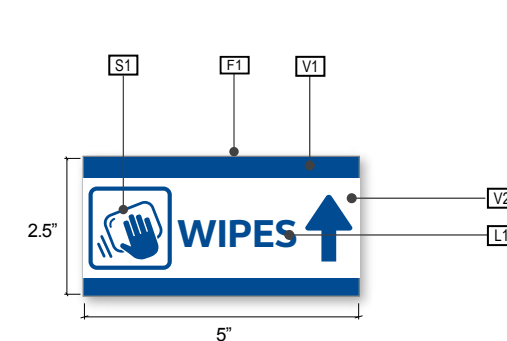
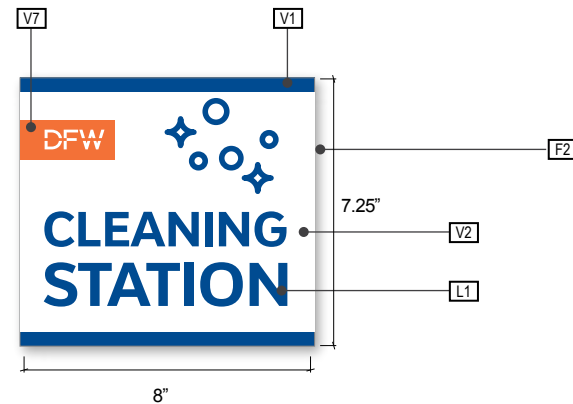
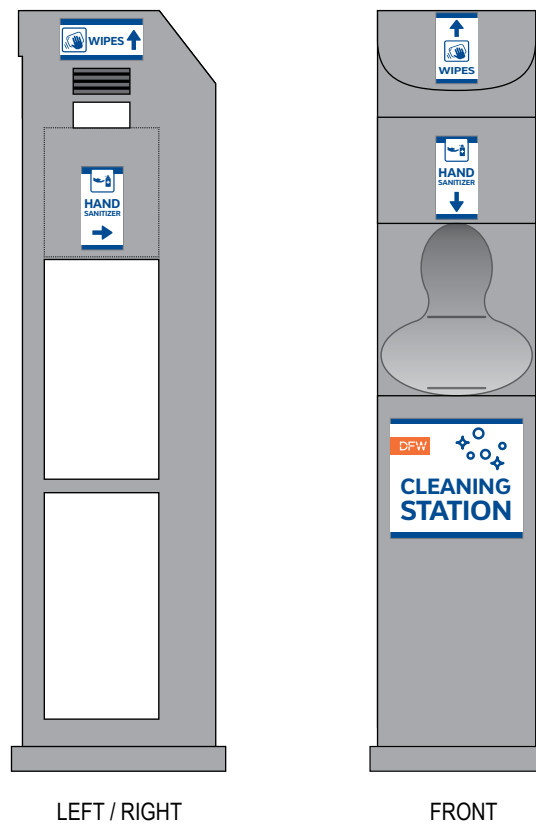

GENERAL NOTES

- All final design, engineering, and amount/sizing of structural sign support elements, material types/thicknesses, dimensions, and attachment methods shall be performed and approved by a licensed engineer to meet or exceed all applicable local and national codes.
- Final engineering, dimensions, materials, and fabrication are the responsibility of the Fabricator to ensure the highest quality fit and finish for all components of the completed product. All final detailing and specifications to be provided by the Fabricator within their final approved fabrication-ready shop drawings.
- Wherever dissimilar metals are in contact, always separate contact surfaces prior to assembly or installation with the necessary protective coatings/gaskets/washers to prevent galvanic corrosion.
- Final fabrication methods, quality and fit/finish to be reviewed and approved by DFW Airport Planning Department and wayfinding/architecture Design Consultants thru prototype reviews prior to final production run/installation processes (see Performance Specifications for details).
- Colors shown are for reference only, and are subject to the limitations of the printing process and/or variance of electronic RGB screen displays. Refer to color system swatches and/or final finish samples for accurate reference.
- Messages shown here are general placeholders only. See graphic message schedules for specific messaging by location and sign type.

FABRICATION INTENT NOTES

- F1** SIGN CABINET/FRAME: modular fabricated internal illuminated edge-lit sign module cabinet constructed of extruded aluminum and cast aluminum components with concealed internal welds; removable sign face and light modules; fabricated aluminum support frame with welded mitered corners and slotted mounting holes to accept sign mounting brackets; fabricated aluminum sign mounting frame with tapered side end cover panels, attached with aluminum pin and clip system; power feed/units hidden behind mounting frame with access holes in back for wall mounting; powdercoat all exposed surfaces of sign cabinet/support frame/mounting frame to match P1, satin finish
- F2** SIGN FACE: fabricated sign face assembly module constructed of extruded aluminum frame and concealed internal welds; faces are 3/16" white acrylic with 1st surface applied V1 vinyl film, graphics reversed out of blue (white is exposed white acrylic cut-thru blue film); faces illuminated with light panel assembly using LED edge-lit clear inscribed acrylic diffuser and self-contained technology (including electronics, extruded frame and diffuser)
- F3** TRIM: .080 fabricated aluminum trim piece with closed ends; detachable and mounted with keyholes/studs and set screws; paint all exposed surfaces to match P2, satin finish
- F4** MOUNTING: mount to wall structural elements with connection system as installation location conditions require (Fabricator to coordinate connection location/type of structural elements with General Contractor); paint all exposed surfaces to match P1, satin finish

GRAPHICS / COLORS / DECORATION NOTES

- L1** Typeface: font = ClearviewText Medium
- L2** Typeface: font = ClearviewText Bold
- L3** BRAILLE: Grade 2 contracted Braille; must meet all applicable ADA/TAS requirements for tactile signage
- L4** Typeface: font = Neue Haas Unica W1G Regular
- S1** Universal Symbols: AIGA style symbol artwork
- S2** Arrow(s): use only official DFW wayfinding arrow artwork
- VINYL (FILM):
- V1** Blue: 3M EC 7725-37 Sapphire Blue
- V2** White: 3M 7725-20 Opaque Matte White
- V3** Skylink Yellow: 3M 7725-114 Enamel Receptive
- V4** Exit Light Green: 3M Opaque Matte to match PMS 368C
- V5** Black: 3M 7725-22 Opaque Matte Black
- V6** Safety Red: 3M Opaque Matte to match PMS 485C
- V7** DFW Orange: 3M Opaque Matte to match PMS 166C

WARNING:

This record contains Sensitive Security Information that is controlled under 49 CFR parts 15 and 1520. No part of this record may be disclosed to persons with a "need to know," as defined in 49 CFR parts 15 and 1520, except with the written permission of the Administrator of the Transportation Security Administration or the Secretary of Transportation. Unauthorized release may result in civil penalty or other action. For U.S. government agencies, public disclosure is governed by 5 U.S.C. 552 and 49 CFR parts 15 and 1520.

9.0

9.0 AIRPORT BOUNDARY SIGN

- 9.1 Sign Types

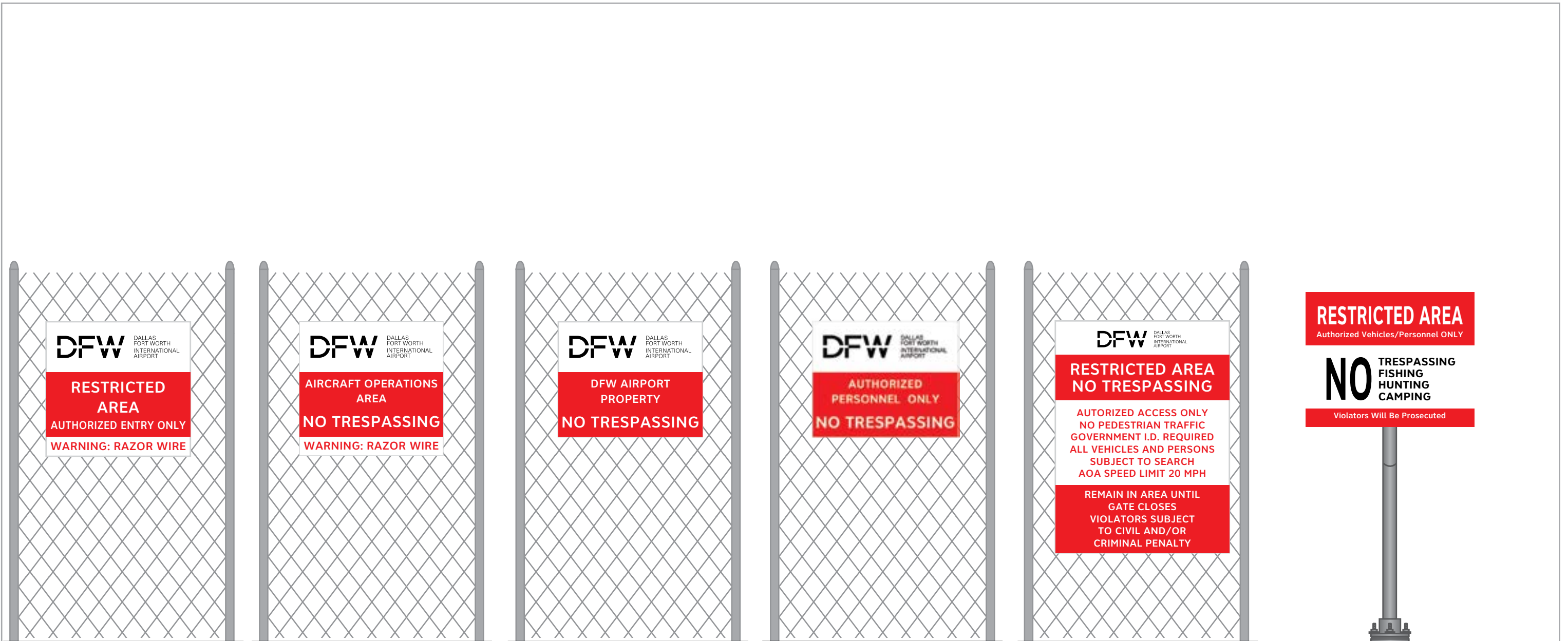

7-RG-01 Restricted Area Sign (28”h x 30”w) 7-RG-02 AOA No Trespassing Sign (28”h x 30”w) 7-RG-03 DFW No Trespassing Sign (24”h x 30”w) 7-RG-04 Authorized Personnel (24”h x 30”w) 7-RG-05 Large Restricted Area Sign (48”h x 36”w) 7-RG-06 No Trespassing Sign (24”h x 30”w)

Figure 1.1.9a DFW Wayfinding Sign Family: **Airport Perimeter Fence Signage**

ILLUMINATION	SIGN TYPE	SIGN FUNCTION	MOUNTING METHOD	GENERAL DESCRIPTION & USE
Reflective	Fence Signage	Regulatory	Fence Mount	Airport Perimeter Fence Signage

GENERAL NOTES

- All final design, engineering, and amount/sizing of structural sign support elements, material types/thicknesses, dimensions, and attachment methods shall be performed and approved by a licensed engineer to meet or exceed all applicable local and national codes.
- Final engineering, dimensions, materials, and fabrication are the responsibility of the Fabricator to ensure the highest quality fit and finish for all components of the completed product. All final detailing and specifications to be provided by the Fabricator within their final approved fabrication-ready shop drawings.
- Wherever dissimilar metals are in contact, always separate contact surfaces prior to assembly or installation with the necessary protective coatings/gaskets/washers to prevent galvanic corrosion.
- Final fabrication methods, quality and finish shall be reviewed and approved by DFW Airport Planning Department and wayfinding/architecture Design Consultants thru prototype reviews prior to final production run/installation processes (see Performance Specifications for details).
- Colors shown are for reference only, and are subject to the limitations of the printing process and/or variance of electronic RGB screen displays. Refer to color system swatches and/or final finish samples for accurate reference.
- Messages shown here are general placeholders only. See graphic message schedules for specific messaging by location and sign type.

FABRICATION INTENT NOTES

- F1** SIGN CABINET/FRAME: modular fabricated internal illuminated edge-lit sign module cabinet constructed of extruded aluminum and cast aluminum components with concealed internal welds; removable sign face and light modules; fabricated aluminum support frame with welded mitered corners and slotted mounting holes to accept sign mounting brackets; fabricated aluminum sign mounting frame with tapered side end cover panels, attached with aluminum pin and clip system; power feed/units hidden behind mounting frame with access holes in back for wall mounting; powdercoat all exposed surfaces of sign cabinet/support frame/mounting frame to match P1, satin finish
- F2** SIGN FACE: fabricated sign face assembly module constructed of extruded aluminum frame and concealed internal welds; faces are 3/16" white acrylic with 1st surface applied V1 vinyl film, graphics reversed out of blue (white is exposed white acrylic cut-thru blue film); faces illuminated with light panel assembly using LED edge-lit clear inscribed acrylic diffuser and self-contained technology (including electronics, extruded frame and diffuser)
- F3** TRIM: .080 fabricated aluminum trim piece with closed ends; detachable and mounted with keyholes/studs and set screws; paint all exposed surfaces to match P2, satin finish
- F4** MOUNTING: mount to wall structural elements with connection system as installation location conditions require (Fabricator to coordinate connection location/type of structural elements with General Contractor); paint all exposed surfaces to match P1, satin finish

GRAPHICS / COLORS / DECORATION NOTES

- L1** Typeface: font = ClearviewText Medium
- L2** Typeface: font = ClearviewText Bold
- L3** BRAILLE: Grade 2 contracted Braille; must meet all applicable ADA/TAS requirements for tactile signage
- S1** Universal Symbols: AIGA style symbol artwork
- S2** Arrow(s): use only official DFW wayfinding arrow artwork
- VINYL (FILM):
 - V1** Blue: 3M EC 7725-37 Sapphire Blue
 - V2** White: 3M 7725-20 Opaque Matte White
 - V3** Skylink Yellow: 3M 7725-114 Enamel Receptive
 - V4** Exit Light Green: 3M Opaque Matte to match PMS 368C
 - V5** Black: 3M 7725-22 Opaque Matte Black
 - V6** Safety Red: 3M Opaque Matte to match PMS 485C
- PAINT:
 - P1** Blue: Powder coated to match 3M EC 7725-37, satin finish
 - P2** Silver: MAP paint # MP30136, satin finish
 - P3** Skylink Yellow: MAP paint to match PMS 130C, satin finish
 - P4** White: MAP paint # MP05317; photopolymer Braille, satin fin.
 - P5** Light Green: MAP Paint to match PMS 368C, satin finish

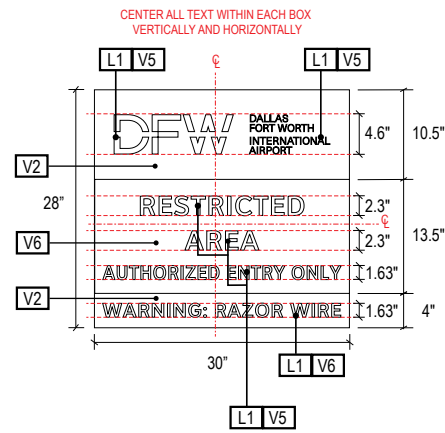

A DETAIL A: Face Layout

Scale: NTS

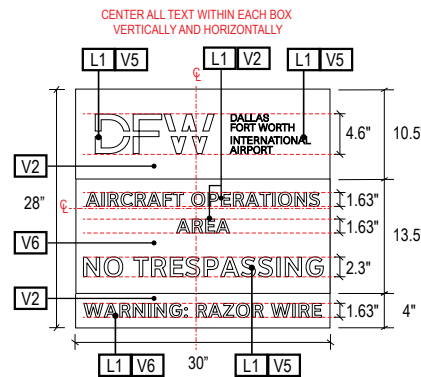

B DETAIL B: Face Layout

Scale: NTS

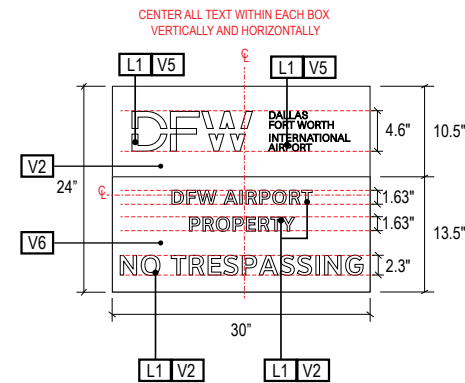

C DETAIL C: Face Layout

Scale: NTS

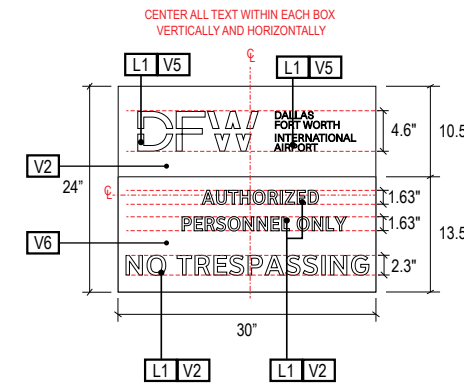

D DETAIL C: Face Layout

Scale: NTS

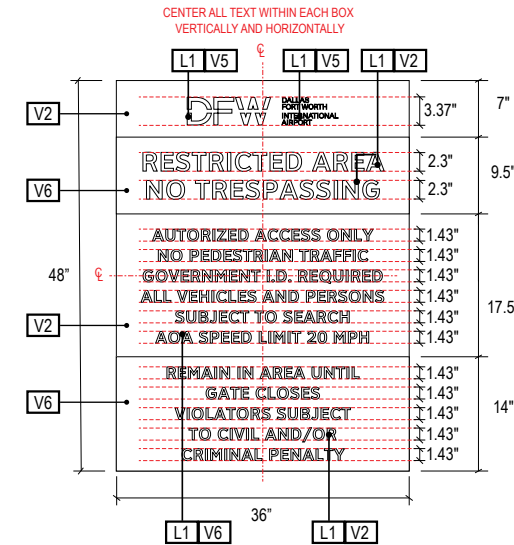

E DETAIL C: Face Layout

Scale: NTS

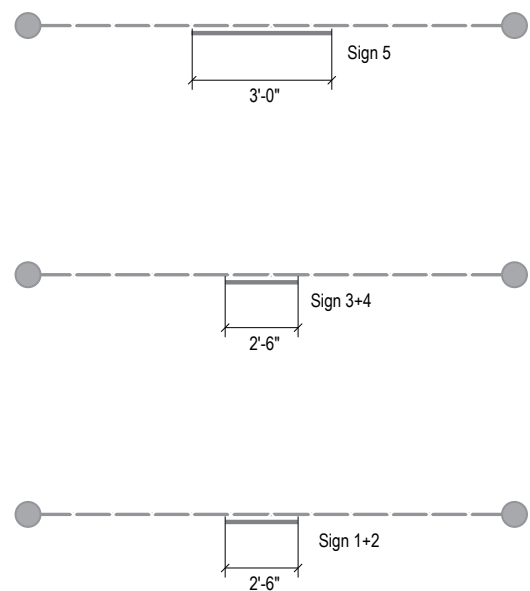

1 PLAN VIEW

Scale: NTS

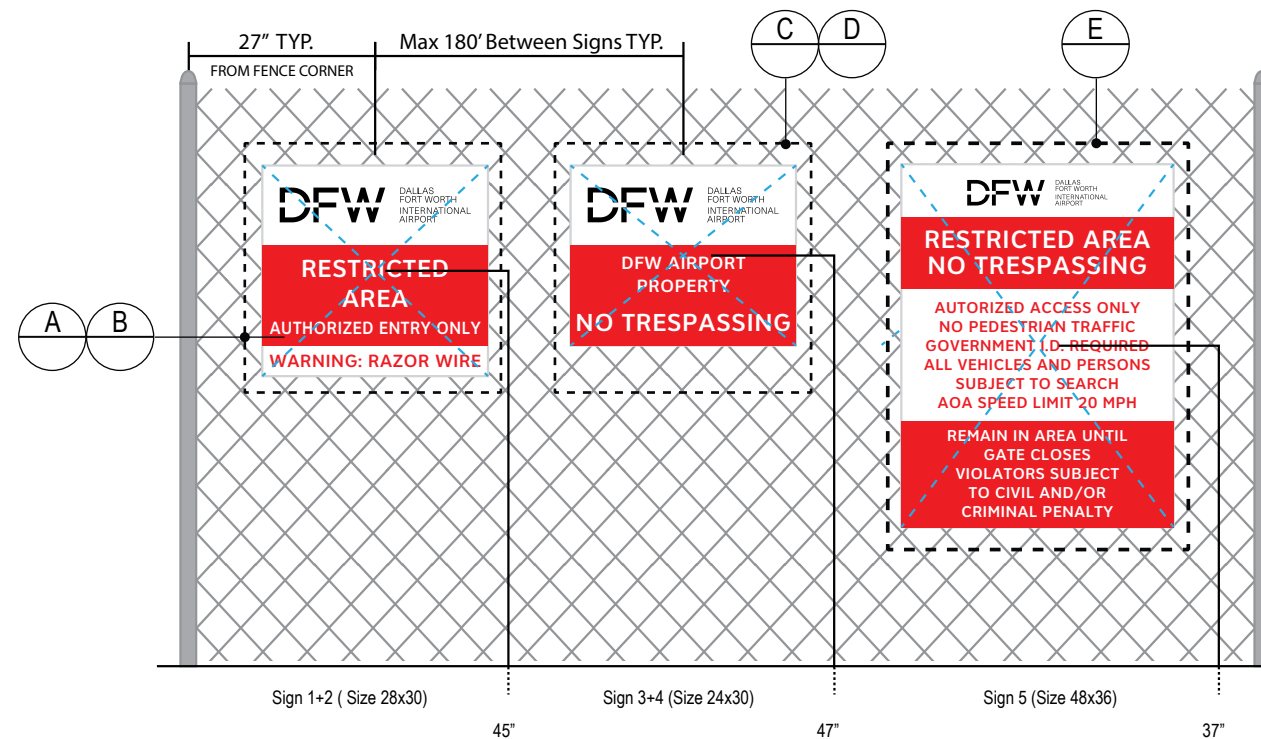

2 ELEVATION

Scale: NTS

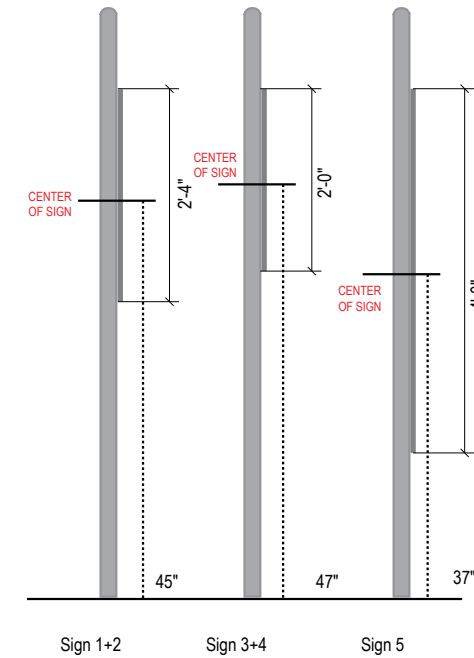

3 END VIEW

Scale: NTS

ILLUMINATION	SIGN TYPE	SIGN FUNCTION	MOUNTING METHOD	GENERAL DESCRIPTION & USE
Reflective	7-RG-06	Regulatory	Pole Mount	Trigg Lake Restricted Area Sign

GENERAL NOTES

- All final design, engineering, and amount/sizing of structural sign support elements, material types/thicknesses, dimensions, and attachment methods shall be performed and approved by a licensed engineer to meet or exceed all applicable local and national codes.
- Final engineering, dimensions, materials, and fabrication are the responsibility of the Fabricator to ensure the highest quality fit and finish for all components of the completed product. All final detailing and specifications to be provided by the Fabricator within their final approved fabrication-ready shop drawings.
- Wherever dissimilar metals are in contact, always separate contact surfaces prior to assembly or installation with the necessary protective coatings/gaskets/washers to prevent galvanic corrosion.
- Final fabrication methods, quality and fit/finish to be reviewed and approved by DFW Airport Planning Department and wayfinding/architecture Design Consultants thru prototype reviews prior to final production run/installation processes (see Performance Specifications for details).
- Colors shown are for reference only, and are subject to the limitations of the printing process and/or variance of electronic RGB screen displays. Refer to color system swatches and/or final finish samples for accurate reference.
- Messages shown here are general placeholders only. See graphic message schedules for specific messaging by location and sign type.

FABRICATION INTENT NOTES

- F1** SIGN CABINET/FRAME: modular fabricated internal illuminated edge-lit sign module cabinet constructed of extruded aluminum and cast aluminum components with concealed internal welds; removable sign face and light modules; fabricated aluminum support frame with welded mitered corners and slotted mounting holes to accept sign mounting brackets; fabricated aluminum sign mounting frame with tapered side end cover panels, attached with aluminum pin and clip system; power feed/units hidden behind mounting frame with access holes in back for wall mounting; powdercoat all exposed surfaces of sign cabinet/support frame/mounting frame to match P1, satin finish
- F2** SIGN FACE: fabricated sign face assembly module constructed of extruded aluminum frame and concealed internal welds; faces are 3/16" white acrylic with 1st surface applied V1 vinyl film, graphics reversed out of blue (white is exposed white acrylic cut-thru blue film); faces illuminated with light panel assembly using LED edge-lit clear inscribed acrylic diffuser and self-contained technology (including electronics, extruded frame and diffuser)
- F3** TRIM: .080 fabricated aluminum trim piece with closed ends; detachable and mounted with keyholes/studs and set screws; paint all exposed surfaces to match P2, satin finish
- F4** MOUNTING: mount to wall structural elements with connection system as installation location conditions require (Fabricator to coordinate connection location/type of structural elements with General Contractor); paint all exposed surfaces to match P1, satin finish

GRAPHICS / COLORS / DECORATION NOTES

- L1** Typeface: font = ClearviewText Medium
- L2** Typeface: font = ClearviewText Bold
- L3** BRAILLE: Grade 2 contracted Braille; must meet all applicable ADA/TAS requirements for tactile signage
- S1** Universal Symbols: AIGA style symbol artwork
- S2** Arrow(s): use only official DFW wayfinding arrow artwork
- VINYL (FILM):
- V1** Blue: 3M EC 7725-37 Sapphire Blue
- V2** White: 3M 7725-20 Opaque Matte White
- V3** Skylink Yellow: 3M 7725-114 Enamel Receptive
- V4** Exit Light Green: 3M Opaque Matte to match PMS 368C
- V5** Black: 3M 7725-22 Opaque Matte Black
- V6** Safety Red: 3M Opaque Matte to match PMS 485C
- PAINT:
- P1** Blue: Powder coated to match 3M EC 7725-37, satin finish
- P2** Silver: MAP paint # MP30136, satin finish
- P3** Skylink Yellow: MAP paint to match PMS 130C, satin finish
- P4** White: MAP paint # MP05317; photopolymer Braille, satin fin.
- P5** Light Green: MAP Paint to match PMS 368C, satin finish

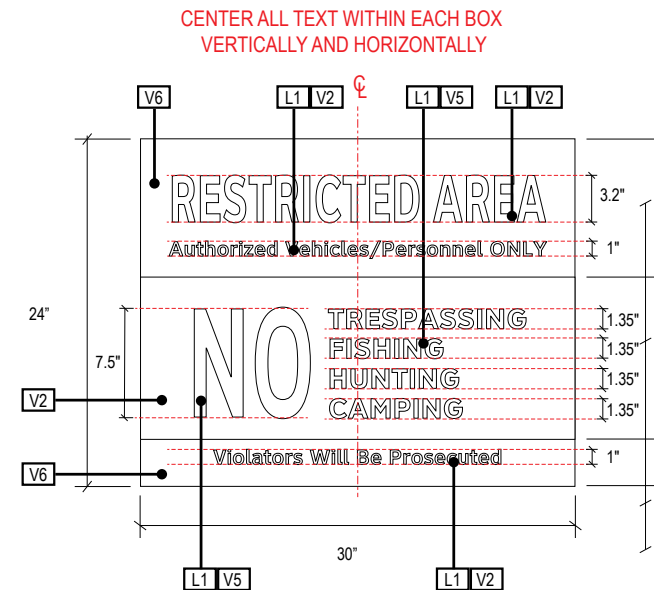

A DETAIL A: Face Layout
Scale: NTS

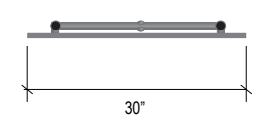

1 PLAN VIEW
Scale: NTS

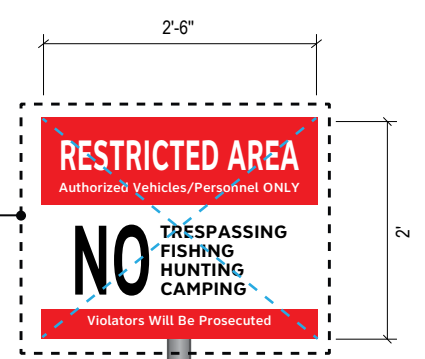

2 ELEVATION
Scale: NTS

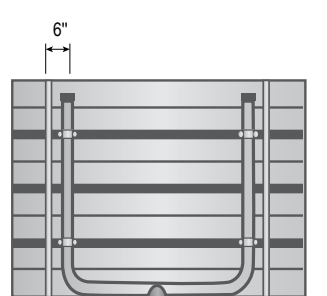

BACK

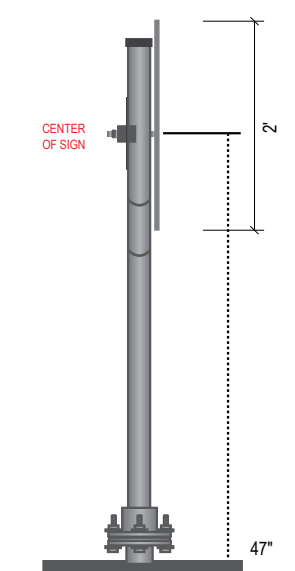

3 END VIEW
Scale: NTS

WARNING:

This record contains Sensitive Security Information that is controlled under 49 CFR parts 15 and 1520. No part of this record may be disclosed to persons with a "need to know," as defined in 49 CFR parts 15 and 1520, except with the written permission of the Administrator of the Transportation Security Administration or the Secretary of Transportation. Unauthorized release may result in civil penalty or other action. For U.S. government agencies, public disclosure is governed by 5 U.S.C. 552 and 49 CFR parts 15 and 1520.

10.0

10.0 APPENDIX : AHQ STANDARD

- 10.1 Cover
- 10.2 Graphic Elements



DFW INTERNATIONAL AIRPORT HEADQUARTERS

Exterior, Garage & Interior Graphic Elements

NOTE: Taken from DFW International Airport
Headquarters document dated March 17, 2014

Project/Document Title:



DALLAS
FORT WORTH
INTERNATIONAL
AIRPORT

**WAYFINDING AND SIGNAGE
STANDARDS AND GUIDELINES**

Prepared by:



LOCHNER
225 W Washington Street
12th Floor
Chicago, IL 60606

Issue Date: 08.24.2017

REV. : 09.30.21
REV. :
REV. :
REV. :

These documents are intended to illustrate design intent, and should only be used as a general guideline. No information contained here should be construed as engineered elements. The fabricator/contractor/installer shall be responsible for all engineering and specifications with regard to structural, electrical, mechanical, foundation and installation. Information and illustrations contained here are part of an original unpublished design by Labozan Associates, Inc. Detailing and information contained on these pages shall not be reproduced, copied or utilized in any way except for the specific project for which they were created without previous written authorization from Labozan Associates, Inc.
© 2017 by Labozan Associates, Inc.

WARNING:

This record contains Sensitive Security Information that is controlled under 49 CFR parts 15 and 1520. No part of this record may be disclosed to persons with a "need to know," as defined in 49 CFR parts 15 and 1520, except with the written permission of the Administrator of the Transportation Security Administration or the Secretary of Transportation. Unauthorized release may result in civil penalty or other action. For U.S. government agencies, public disclosure is governed by 5 U.S.C. 552 and 49 CFR parts 15 and 1520.

Paint

All interior finishes to be Eggshell unless specified otherwise.
All paint to be exterior grade w/ UV inhibitors.

- P1 White**
Matthews Paint
MP32071
- P2 Directional Blue**
Matthews Custom Match
Pantone 300 C
- P3 Wayfinding Blue**
Matthews Custom Match
Pantone 662 C
- P4 Carribean Coast**
Matthews Custom Match
Benjamin Moore 2065-60 Carribean Coast
- P5 Blue Wave**
Matthews Custom Match
Benjamin Moore 2065-50 Blue Wave
- P6 Utah Sky**
Matthews Custom Match
Benjamin Moore 2065-40 Utah Sky
- P7 Garage Red**
Matthews Custom Match
Pantone 186C
- P8 Garage Purple**
Matthews Custom Match
Pantone 2587C
- P9 Garage Yellow**
Matthews Custom Match
Pantone 108C
- P10 Green**
Matthews Custom Match
Pantone 354C
- P11 White Dove**
Matthews Custom Match
Benjamin Moore OC-17 White Dove
- P12 Collonade Gray**
Matthews Custom Match
Sherwin Williams SW7641 Collonade Gray

- P13 Black**
Matthews Custom Match
Pantone Black
- P14 Silver**
Matthews Custom Match
MP18128 Cool Metallic
- P15 Logo Light Blue**
Matthews Custom Match
Pantone 299 CVC
- P16 Logo Dark Blue**
Matthews Custom Match
Pantone 2955 CVC
- P17 Light Grey**
Matthews Custom Match
Pantone Cool Grey 1C
- P18 Dark Grey**
Matthews Custom Match
Pantone Cool Grey 10C

Metal

- M1 Brushed Aluminum**
Standard #4 Finish
(horizontal grain)
- M2 Brushed Aluminum**
Standard #4 Finish
(vertical grain)
- M3 Sandblasted Metal**
Custom Light Sandblasted Finish
- M4 Brushed Stainless Steel**
Standard #4 Finish

Acrylic

- A1 Textured Acrylic**
Acrylite
Colorless 0A000 BO

Vinyl

- V1 White**
3M Brand (no substitutions)
Scotchcal 7725-20 Matte White
- V2 Reflective White**
3M Brand (no substitutions)
Scotchcal 690-10 White
- V3 Dusted Crystal**
3M Brand (no substitutions)
Scotchcal 7725-314 Dusted Crystal
- V4 Red**
3M Brand (no substitutions)
Scotchcal 7725-63 Geranium
- V5 Reflective Red**
3M Brand (no substitutions)
Scotchcal 690-82 Ruby Red
- V6 Black**
3M Brand (no substitutions)
Scotchcal 7725-12 Black
- V7 Sunflower**
3M Brand (no substitutions)
Scotchcal 7725-25 Sunflower
- V8 Reflective Green**
3M Brand (no substitutions)
Scotchcal 2277 Green
- V9 Reflective Blue**
3M Brand (no substitutions)
Scotchcal 2275 Blue
- V10 Silver**
3M Brand (no substitutions)
Scotchcal 7725-120 Satin Aluminum
- V11 Translucent White**
3M Brand (no substitutions)
Scotchcal 3630-20 White

NOTE: Taken from DFW International Airport Headquarters document dated March 17, 2014

F Clearview Hwy 3-W
0% Kerning except as noted
 ABCDEFGHIJKLMNOPQRSTUVWXYZ0123456789
 abcdefghijklmnopqrstuvwxyz.,:;()/?!@#%&

E Clearview Hwy 2-W
0% Kerning except as noted
 ABCDEFGHIJKLMNOPQRSTUVWXYZ0123456789
 abcdefghijklmnopqrstuvwxyz.,:;()/?!@#%&

D Clearview Hwy 2-B
0% Kerning except as noted
 ABCDEFGHIJKLMNOPQRSTUVWXYZ0123456789
 abcdefghijklmnopqrstuvwxyz.,:;()/?!@#%&

C Clearview Text Bold
0% Kerning except as noted
 ABCDEFGHIJKLMNOPQRSTUVWXYZ0123456789
 abcdefghijklmnopqrstuvwxyz.,:;()/?!@#%&

B Clearview Text Medium
0% Kerning except as noted
 ABCDEFGHIJKLMNOPQRSTUVWXYZ0123456789
 abcdefghijklmnopqrstuvwxyz.,:;()/?!@#%&

A Clearview Text Book
0% Kerning except as noted
 ABCDEFGHIJKLMNOPQRSTUVWXYZ0123456789
 abcdefghijklmnopqrstuvwxyz.,:;()/?!@#%&

NOTE: Taken from DFW International Airport Headquarters document dated March 17, 2014

L ABCDEFGHIJKLMNOPQRSTUVWXYZ0123456789
abcde fghijklmnopqrstuvwxyz.,:;()/?!@#%&
Avenir
95 Black
0% Kerning
except as noted

K ABCDEFGHIJKLMNOPQRSTUVWXYZ0123456789
abcde fghijklmnopqrstuvwxyz.,:;()/?!@#%&
Avenir
85 Heavy
0% Kerning
except as noted

J ABCDEFGHIJKLMNOPQRSTUVWXYZ0123456789
abcde fghijklmnopqrstuvwxyz.,:;()/?!@#%&
Avenir
55 Roman
0% Kerning
except as noted

I ABCDEFGHIJKLMNOPQRSTUVWXYZ0123456789
abcde fghijklmnopqrstuvwxyz.,:;()/?!@#%&
Avenir
35 Light
0% Kerning
except as noted

H ABCDEFGHIJKLMNOPQRSTUVWXYZ0123456789
abcde fghijklmnopqrstuvwxyz.,:;()/?!@#%&
Clearview Hwy
5-W
0% Kerning
except as noted

G ABCDEFGHIJKLMNOPQRSTUVWXYZ0123456789
abcde fghijklmnopqrstuvwxyz.,:;()/?!@#%&
Clearview Hwy
4-W
0% Kerning
except as noted

NOTE: Taken from DFW International Airport Headquarters document dated March 17, 2014

DFW Airport Headquarters

A
Cut Letters
M1 Face
M3 Returns

2.5"

2 Elevation / 1 1/2" = 1' - 0"

B

Frame
M1 Face
M3 Returns

C

Bar
M1 Face
M3 Returns

D

Textured Panel
P6 Flight Level 003
P5 Flight Level 002
P4 Flight Level 001

E

Message Panel
P6 Level 3
P5 Level 2
P4 Level 1
P1 Text

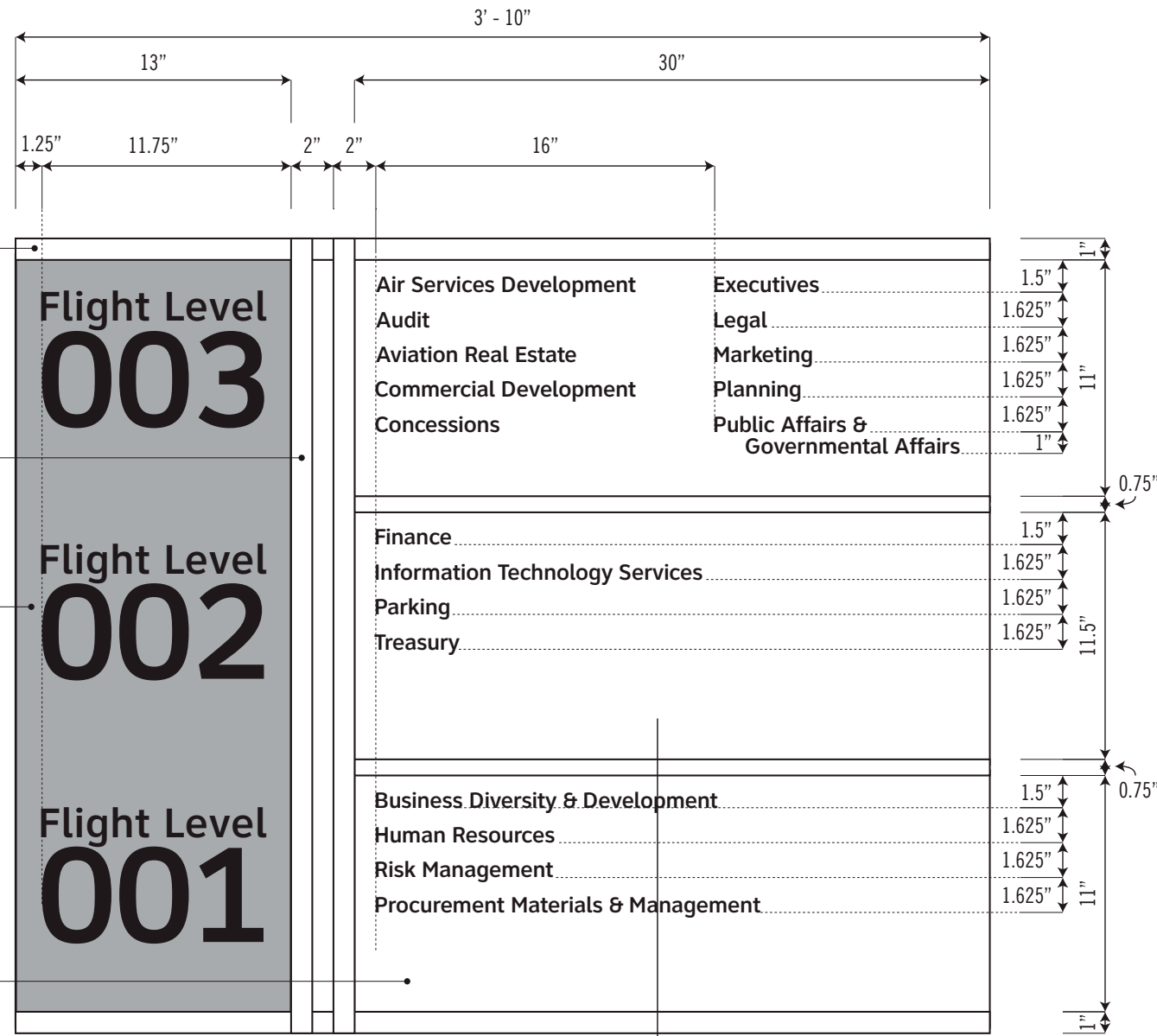

1 Elevation / 1 1/2" = 1' - 0"

B

Frame

Spacer

E

Message Panel

A Section Detail / Half Size Schematic

Dimensions & shapes of all elements as shown on G3.B1a thru G3.B1b.

A Cut Letters:

Computer cut letters of 0.75" thick aluminum. Use Laser or Waterjet cutting method for minimal inside corner radius. Buff returns smooth and even to eliminate any tooling marks. Drill and tap reverse of each element for not less than 3 threaded studs. Finish all surfaces as indicated. Apply thin matte finish clear coat to all surfaces.

Typography:

Clearview Text Medium, 2.5" Cap Height (Based on "E"), Kerned -32%

B Frame:

Fabricated form of not less than 0.125" Aluminum. All welded construction. Grind and buff all welds smooth. No Visible tooling marks or seams. Configured with incorporated spacer to hold message & textured panel tight into frame. Configured so panels can be removable. Finish all surfaces as indicated. Apply thin matte finish, clear coat to all surfaces.

C Bar:

Aluminum bar, 0.25" thick by 1" wide, cut length. buff ends smooth and even to eliminate all tooling marks. Finish all surfaces as indicated. Apply thin matte finish clearcoat to all surfaces. Concealed mechanical attachment flush to frame. Position as indicated.

D Textured Panel:

Textured acrylic panel of 0.125" thickness, Acrylite Colorless 0A000 B0, cut to size. Texture to be second surface. Text to be screen printed to first Surface (non-textured surface) with paint color indicated.

Typography:

"Flight Level" - Clearview Text Book, 1.375" Cap Height (Based on "E"), Kerned 0. For "001", "002", "003" - Clearview Text Medium, 4.5" Cap Height (Based on "1"), Kerned -50%.

E Message Panel:

Acrylic panel of 0.25" thickness, cut to size. Buff returns smooth, finish all surfaces as indicated. Graphics to be screened first surface.

Installation:

Concealed mechanical attachment of frame and message assembly flush to wall, locate as indicated. Concealed pin and silicone mount letters flush to wall.

NOTE: Taken from DFW International Airport Headquarters document dated March 17, 2014

Dimensions & shapes of all elements as shown on G3.B1a thru G3.B1b.

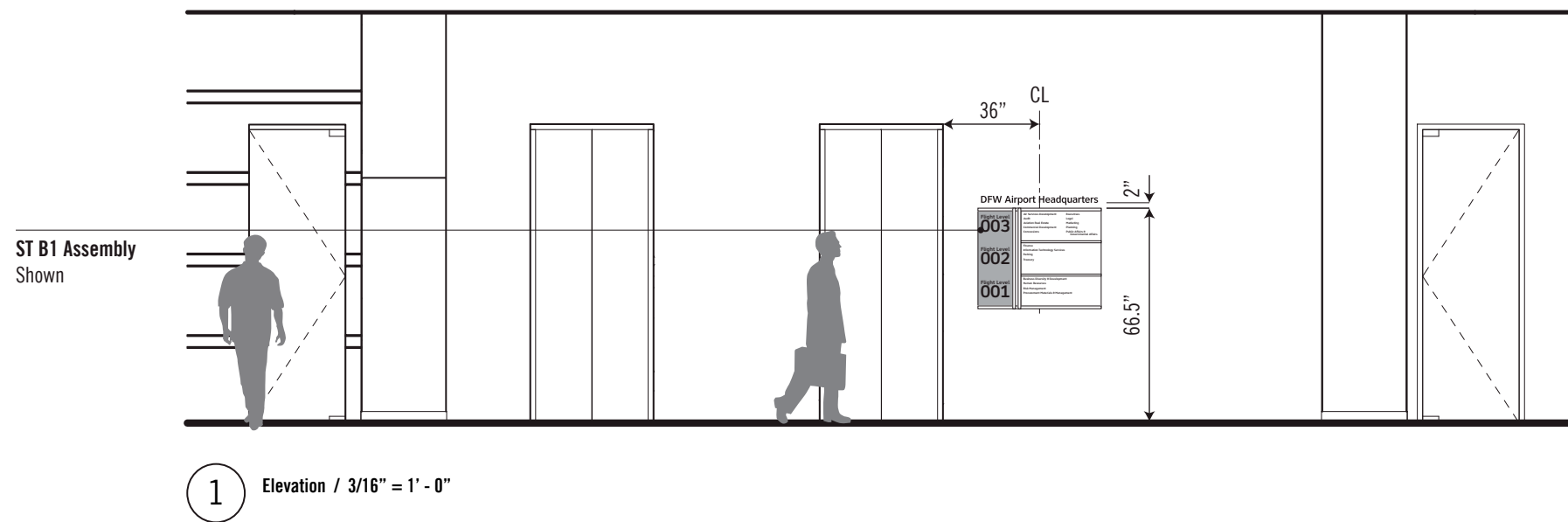

NOTE: Taken from DFW International Airport Headquarters document dated March 17, 2014

WARNING:

This record contains Sensitive Security Information that is controlled under 49 CFR parts 15 and 1520. No part of this record may be disclosed to persons with a "need to know," as defined in 49 CFR parts 15 and 1520, except with the written permission of the Administrator of the Transportation Security Administration or the Secretary of Transportation. Unauthorized release may result in civil penalty or other action. For U.S. government agencies, public disclosure is governed by 5 U.S.C. 552 and 49 CFR parts 15 and 1520.

Dimensions & shapes of all elements as shown on G3.B2a.

A Textured Panel:
Textured acrylic panel of 0.125" thickness, Acrylite Colorless 0A000 B0, cut to size. Buff returns smooth and even to eliminate any tooling marks. Texture to be second surface. Text to be screen printed to first Surface (non-textured surface) as indicated.

Typography:
"Flight Level" - Clearview Text Book, 0.3125" Cap Height (Based on "F"), Kerned 0.
"001", "002", "003" - Clearview Text Medium, 1" Cap Height (Based on "1"), Kerned -50%.

B Digital Print:
Computer Cut digitally printed vinyl. First surface application. Sign Contractor responsible for color match digital print to indicated colors.

Installation:
Concealed 3M VHB tape & silicone mount flush to elevator cab wall. Sign contractor to field verify conditions prior to fabrication.

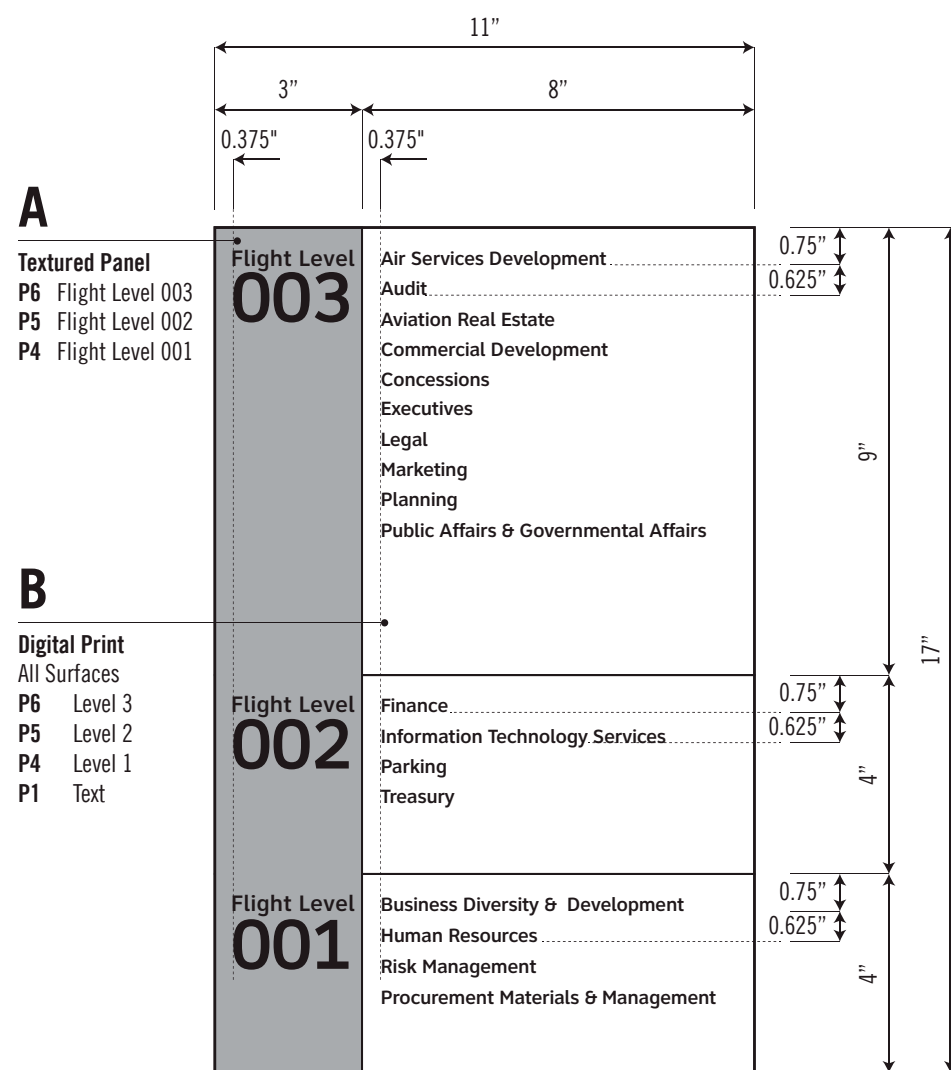

1 Elevation / 3" = 1' - 0"

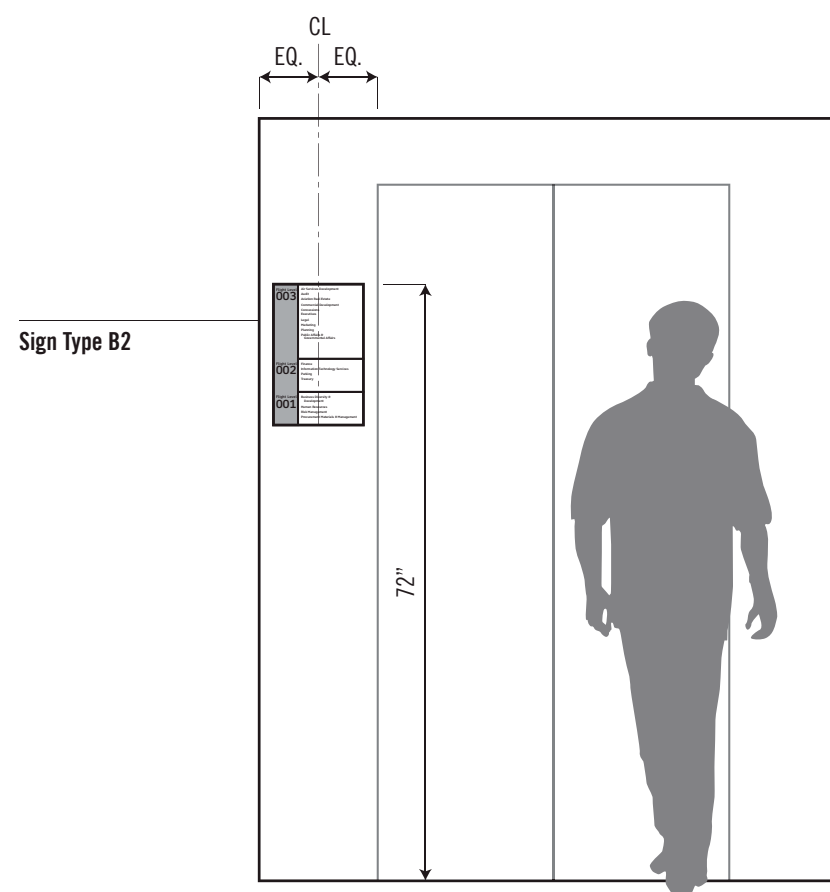

2 Elevation / 1/2" = 1' - 0"

NOTE: Taken from DFW International Airport Headquarters document dated March 17, 2014

WARNING:

This record contains Sensitive Security Information that is controlled under 49 CFR parts 15 and 1520. No part of this record may be disclosed to persons with a "need to know," as defined in 49 CFR parts 15 and 1520, except with the written permission of the Administrator of the Transportation Security Administration or the Secretary of Transportation. Unauthorized release may result in civil penalty or other action. For U.S. government agencies, public disclosure is governed by 5 U.S.C. 552 and 49 CFR parts 15 and 1520.

Dimensions & shapes of all elements as shown on G3.B4a thru G3.B4b.

A Logo Panel:
Stainless steel plate of 0.25" thickness, cut to size. Buff returns smooth and even to eliminate any tooling marks. Etch graphics and surfaces as indicated. Design to provide artwork for logo.

Installation:
Concealed mechanical attachment of logo panel to wood wall with concealed full angle frame inset from all edges as indicated.

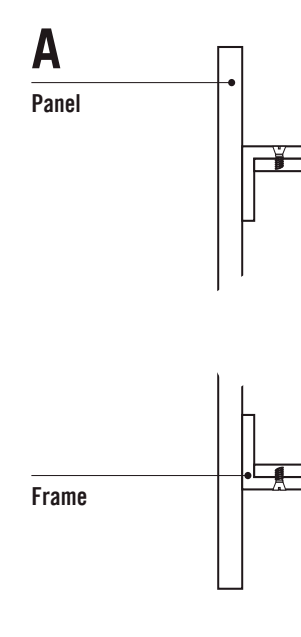

A Section Detail / Half Size



1 Elevation / 1 1/2" = 1' - 0"

2 Side View / 1 1/2" = 1' - 0"

NOTE: Taken from DFW International Airport Headquarters document dated March 17, 2014

Dimensions & shapes of all elements as shown on G3.B4a thru G3.B4.

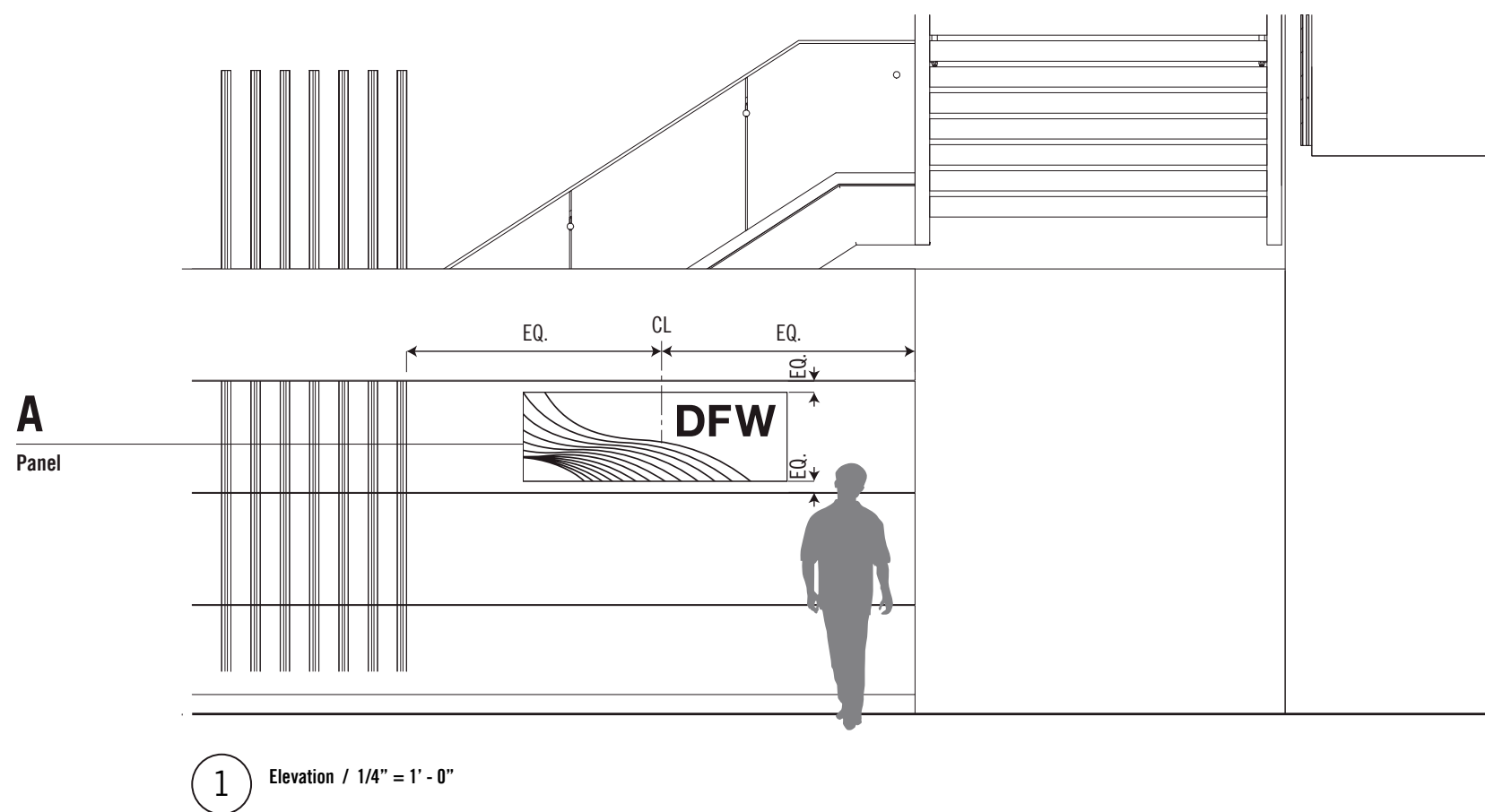

NOTE: Taken from DFW International Airport Headquarters document dated March 17, 2014

Dimensions & shapes of all elements as shown on G3.B5a.

A Vinyl:
3M Computer Cut Vinyl graphics to be applied to first surface of glass. Color as indicated.

Typography:
For "DFW Airport Headquarters" Clearview Text Bold, 1.5" Cap Height (Based on "E"), Kerned -25%; For Hours of Operation, Clearview Text Medium, 1" Cap Height (Based on "E"), Kerned -25%; For Symbol Text, 0.5" Cap Height (Based on "E"), Kerned -25%. Interline spacing for all as indicated.

Symbols:
3" Height

Installation:
Clean surface & apply vinyl to first surface.



1 Elevation / 3" = 1' - 0"

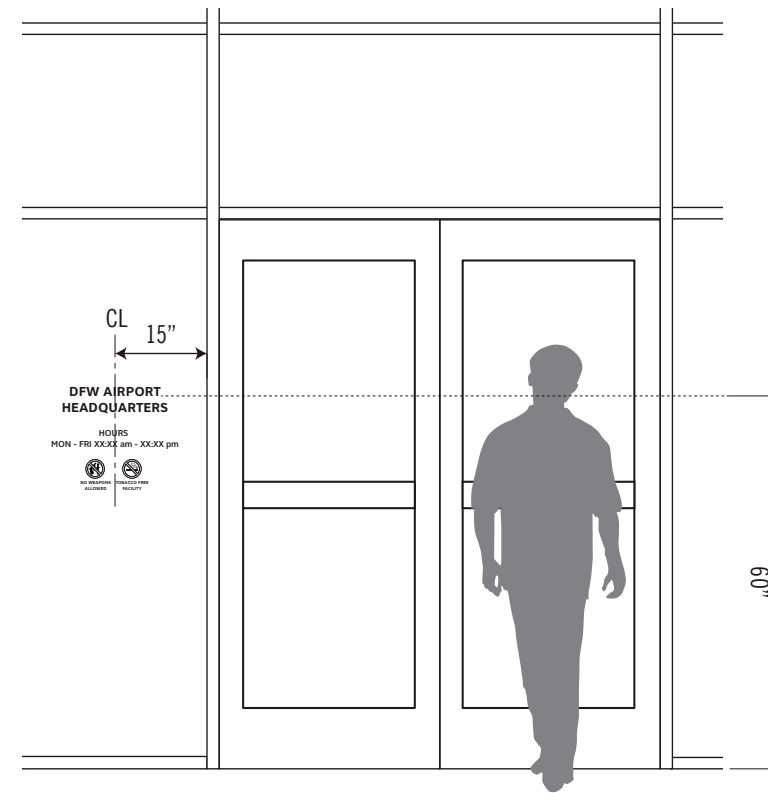

2 Elevation / 3/8" = 1' - 0"

NOTE: Taken from DFW International Airport Headquarters document dated March 17, 2014

Dimensions & shapes of all elements as shown on G3.E6a.

A Cut Letters:

Aluminum letters of 0.5" thickness to be computer cut. Buff returns smooth and even to eliminate any tooling marks. Finish all surfaces as indicated. Concealed mechanical attachment to baseplate. all letters to be plumb.

Typography:

Clearview Text Bold, 4" Cap Height (Based on "M"), Kerned 0.

B Baseplate:

Aluminum plate of 0.25" thickness, cut to length of letters. Buff returns smooth and even to eliminate any tooling marks. Finish as indicated.

Installation:

Concealed mechanical attachment to top of soffit.

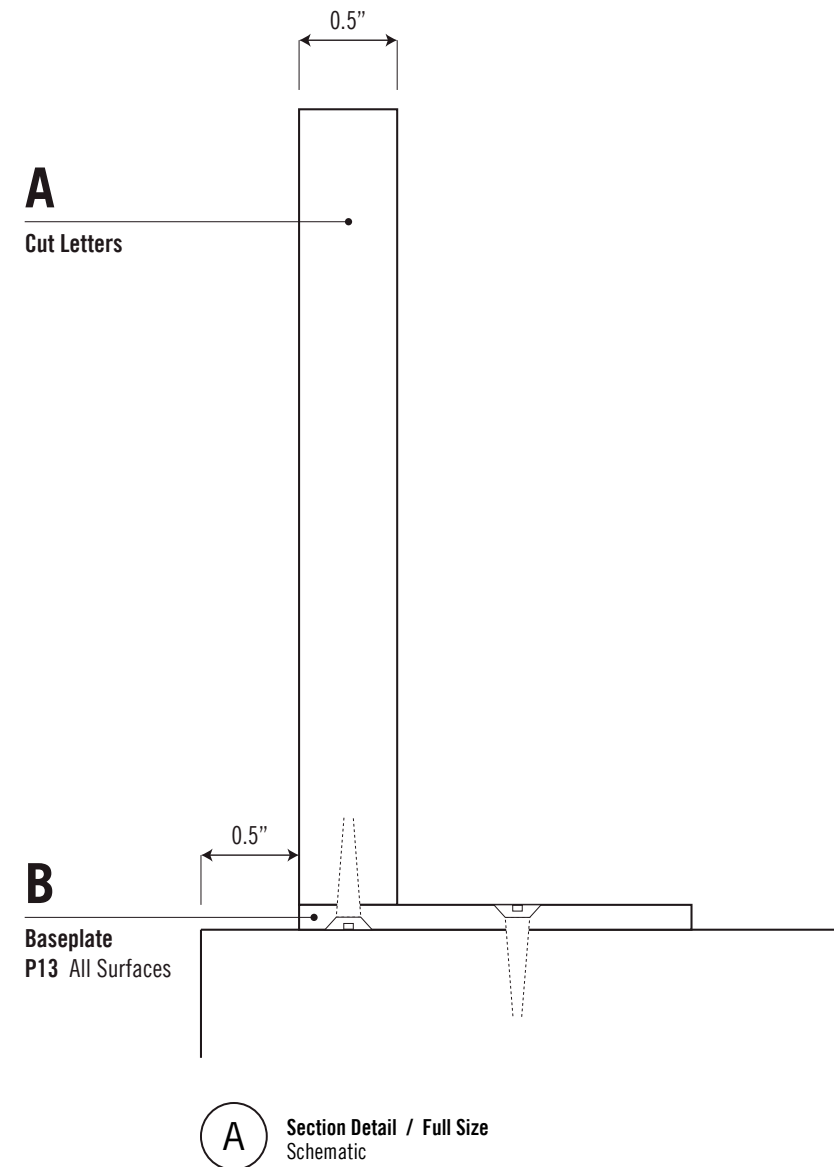
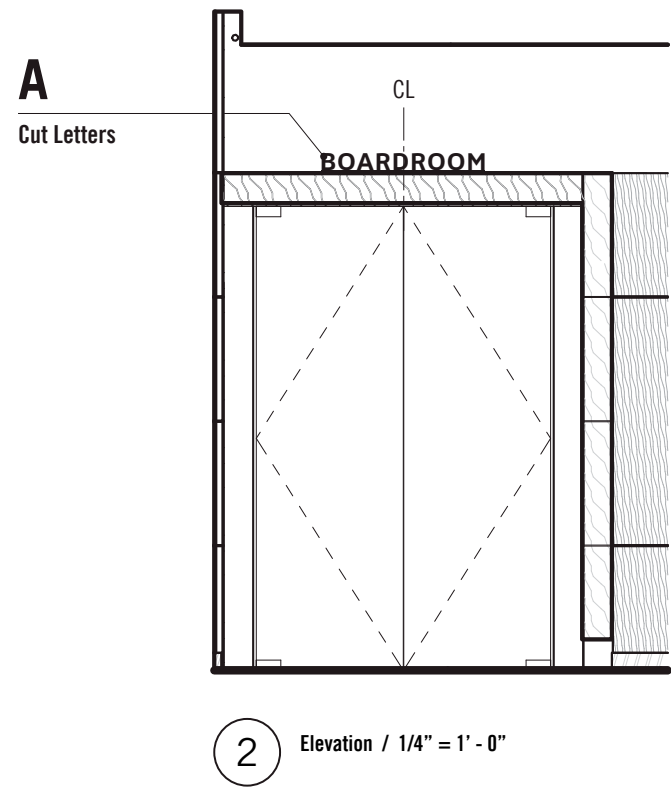

NOTE: Taken from DFW International Airport Headquarters document dated March 17, 2014

Dimensions & shapes of all elements as shown on G3.B7a.

A Tactile Plaque:
Photopolymer Plaque, 0.25" thickness, w/ raised graphics and Grade 2 Braille. Buff returns smooth and even to eliminate tooling marks. Paint finish all surfaces as indicated.

Typography:
Clearview Text Medium, 0.625" Cap Height (Based on "E"), Kerned +25%. Interline spacing of 1.125".

Grade 2 Braille:
Height, kerning & leading per requirements of the DOJ's 2010 ADA Standards for Accessible Design.

B Accent:
Acrylite Colorless 0A000 B0 textured acrylic panel, 0.125" thickness, cut to size, texture to be first surface. Rout grooves into face, no greater than 0.0625" configured to accept Bars. Polish returns clear, smooth and even, backpaint as indicated. Laminate to Tactile Plaque using concealed adhesive sheeting, aligning edges.

C Bars:
Aluminum Bars 0.25" wide by 0.125" thick, cut to length. Buff edges smooth and even to eliminate any tooling marks. Finish as indicated. Apply thin and even matte finish clearcoat to all surfaces and laminate to Accent with concealed adhesive.

Installation:
Concealed 3M VHB tape & silicone mount flush to wall adjacent to latch side of door. Locate 58" to centerline of plaque from finished floor, 2" from door frame. At outswinging door locations maintain distance specified in DOJ 2010 ADA Standards for Accessible Design.

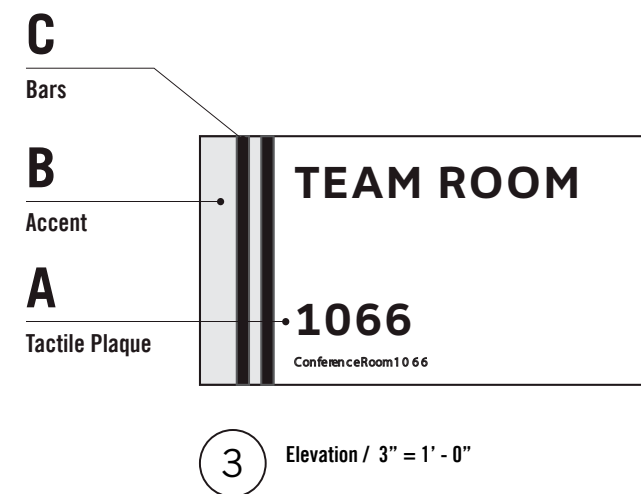
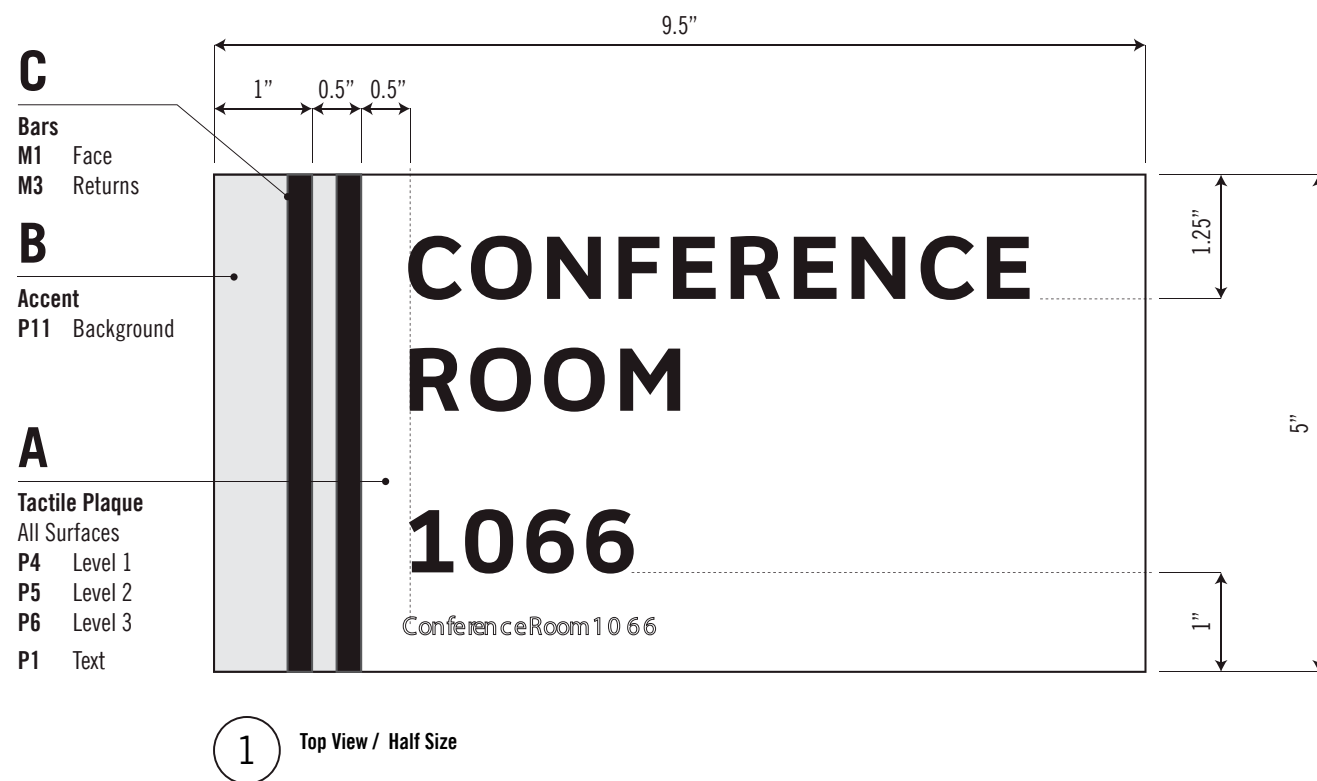
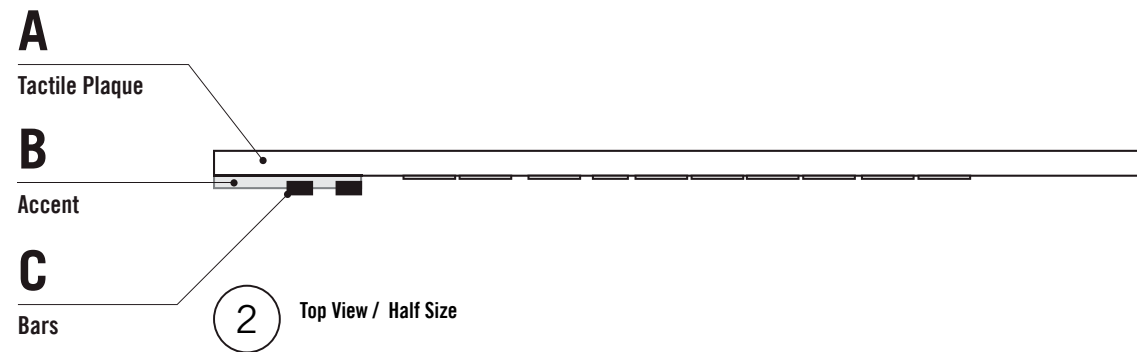

NOTE: Taken from DFW International Airport Headquarters document dated March 17, 2014

Dimensions & shapes of all elements as shown on G3.B8a.

A Tactile Plaque:
Photopolymer Plaque, 0.25" thickness, w/ raised graphics and Grade 2 Braille. Buff returns smooth and even to eliminate tooling marks. Paint finish all surfaces as indicated.

Typography:
Clearview Text Medium, 0.625" Cap Height (Based on "E"), Kerned +25%. Interline spacing of 1.125".

Grade 2 Braille:
Height, kerning & leading per requirements of the DOJ's 2010 ADA Standards for Accessible Design.

B Accent:
Acrylite Colorless 0A000 B0 textured acrylic panel, 0.125" thickness, cut to size, texture to be first surface. Rout grooves into face, no greater than 0.0625" configured to accept Bars. Polish returns clear, smooth and even, backpaint as indicated. Laminate to Tactile Plaque using concealed adhesive sheeting, aligning edges.

C Bars:
Aluminum Bars 0.25" wide by 0.125" thick, cut to length. Buff edges smooth and even to eliminate any tooling marks. Finish as indicated. Apply thin and even matte finish clearcoat to all surfaces and laminate to Accent with concealed adhesive.

Installation:
Concealed 3M VHB tape & silicone mount flush to wall adjacent to latch side of door. Locate 58" to centerline of plaque from finished floor, 2" from door frame. At outswinging door locations maintain distance specified in DOJ 2010 ADA Standards for Accessible Design.

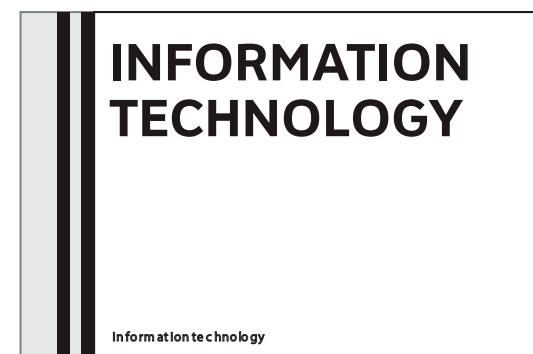
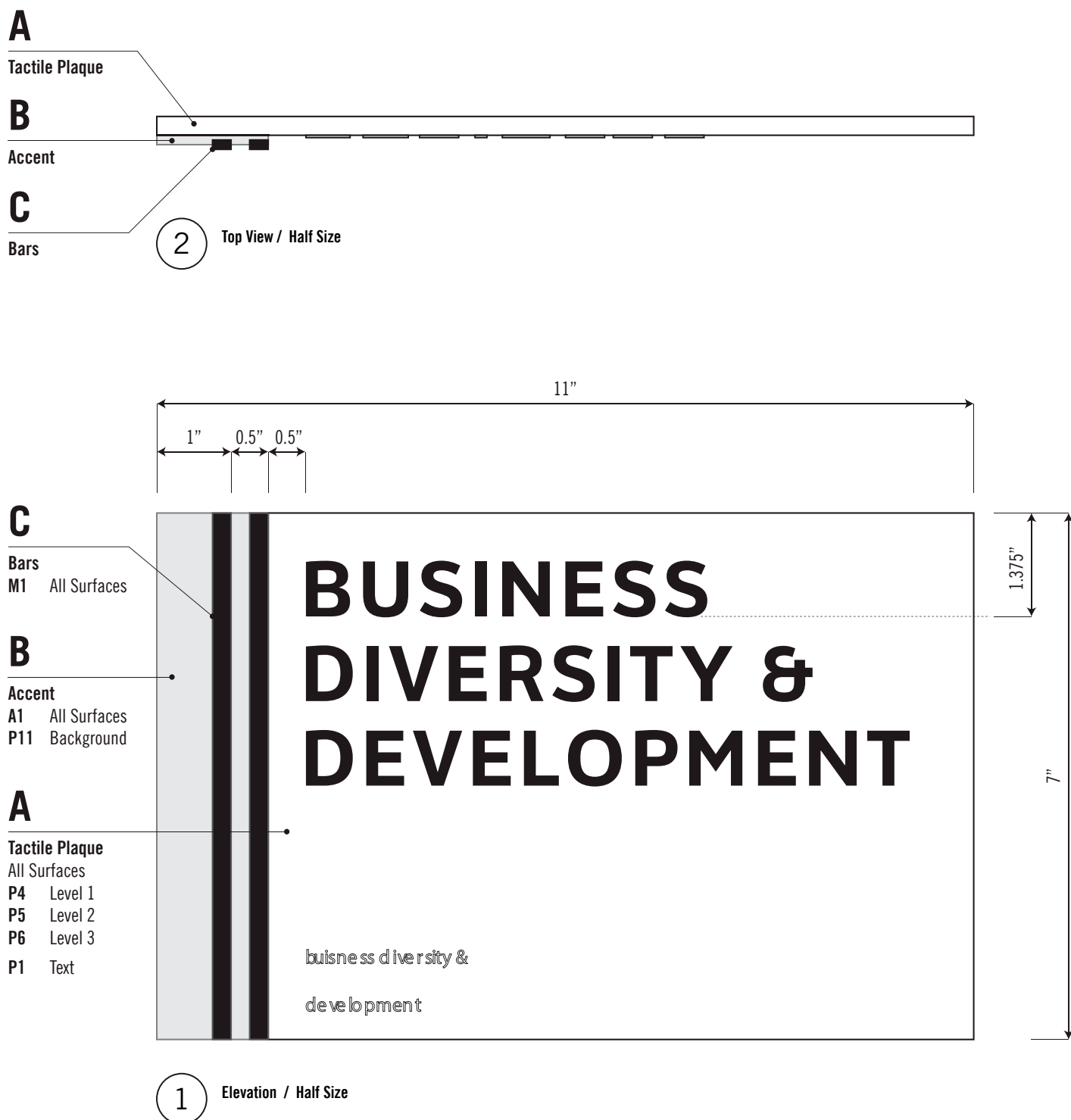

3 Elevation / 3" = 1' - 0" Alternate Layouts

NOTE: Taken from DFW International Airport Headquarters document dated March 17, 2014

Dimensions & shapes of all elements as shown on G3.B9.

A Tactile Plaque:
Photopolymer Plaque, 0.25" thickness, w/ raised graphics and Grade 2 Braille. Buff returns smooth and even to eliminate tooling marks. Paint finish all surfaces as indicated.

Typography:
Clearview Text Medium, 0.625" Cap Height (Based on "E"), Kerned +25%. Interline spacing of 1.125".

Bars: 0.25" width.

Grade 2 Braille:
Height, kerning & leading per requirements of the DOJ's 2010 ADA Standards for Accessible Design.

Installation:
Concealed 3M VHB tape & silicone mount flush to wall adjacent to latch side of door. Locate 58" to centerline of plaque from finished floor, 2" from door frame. At outswinging door locations maintain distance specified in DOJ 2010 ADA Standards for Accessible Design.

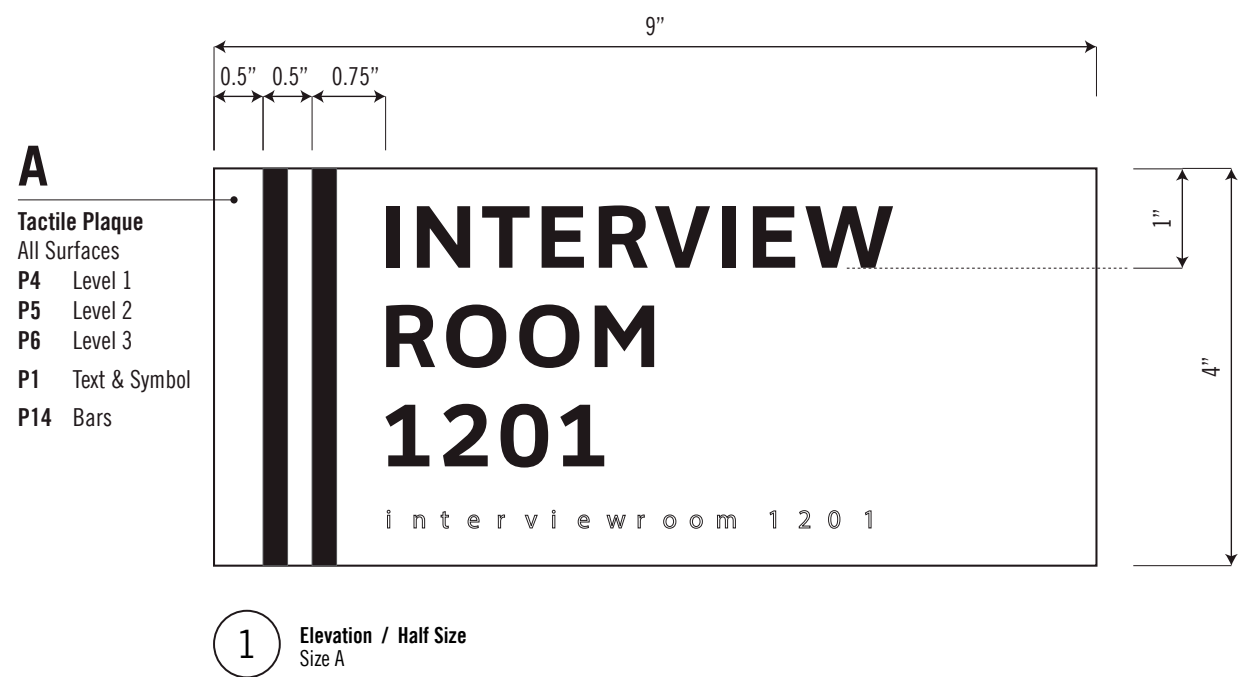
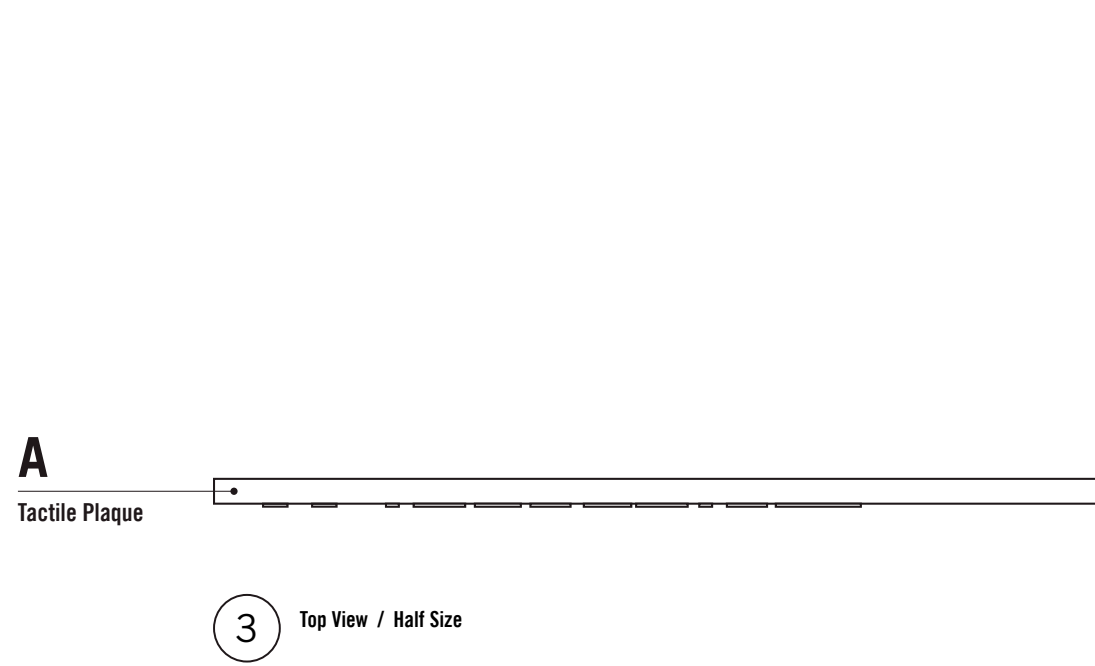

NOTE: Taken from DFW International Airport Headquarters document dated March 17, 2014

WARNING:

This record contains Sensitive Security Information that is controlled under 49 CFR parts 15 and 1520. No part of this record may be disclosed to persons with a "need to know," as defined in 49 CFR parts 15 and 1520, except with the written permission of the Administrator of the Transportation Security Administration or the Secretary of Transportation. Unauthorized release may result in civil penalty or other action. For U.S. government agencies, public disclosure is governed by 5 U.S.C. 552 and 49 CFR parts 15 and 1520.

Dimensions & shapes of all elements as shown on G3.B10a.

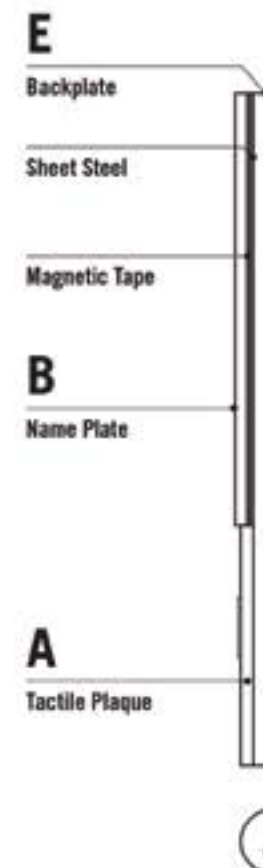
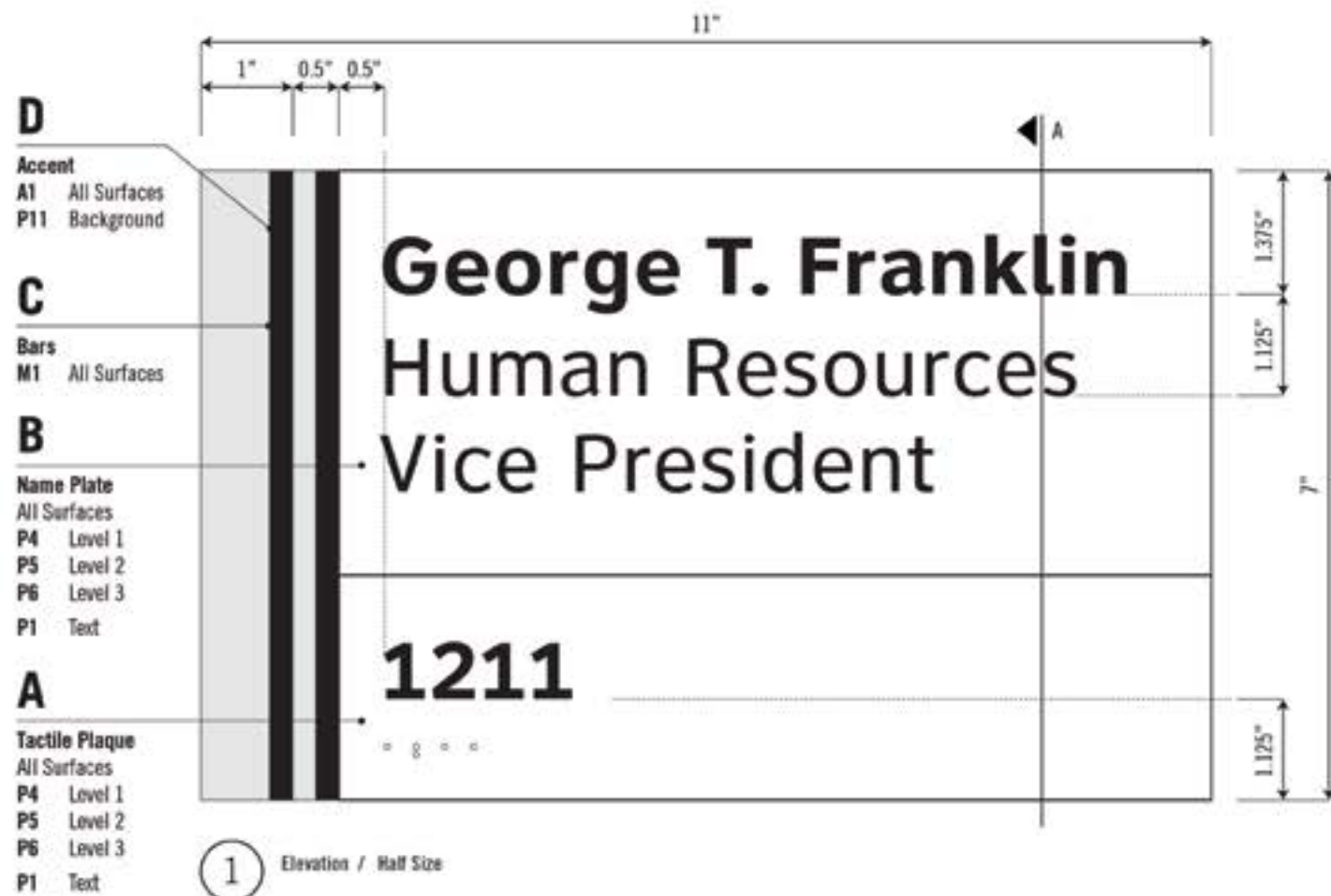
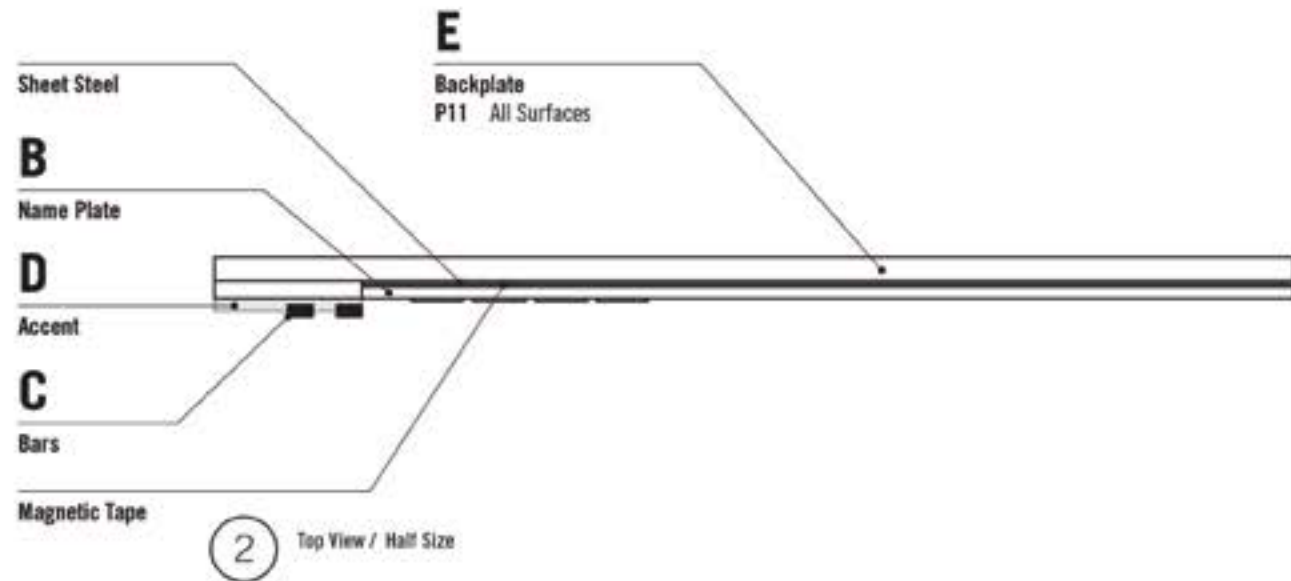

A Tactile Plaque:
Photopolymer, 0.125" thickness, w/ raised graphics and Grade 2 Braille. Buff returns smooth and even to eliminate any tooling marks. Finish all surfaces as indicated.

Typography:
Clearview Text Medium, 0.625" Cap Height (Based on "E"), Kerned +25%. Interline spacing of 1.125".

Grade 2 Braille:
Height, kerning & leading per requirements of the DOJ's 2010 ADA Standards for Accessible Design.

B Name Plate:
Acrylic sheet, 0.125" thickness, cut to size. Buff returns smooth and even to eliminate any tooling marks. Paint finish all surfaces as indicated. Screen print text to first surface. Configured with concealed magnetic tape.

Typography:
Name: Clearview Text Bold, 0.75" Cap Height (Based on "E"); Title & Department: Clearview Text Book, 0.625" Cap Height (Based on "E"). Interline spacing as indicated.

C Bars:
Aluminum Bars 0.25" wide by 0.125" thick with vertical brush finish, cut to length. Buff edges smooth and even to eliminate any tooling marks. Apply thin and even matte finish clearcoat to all surfaces and laminate to Accent with concealed adhesive.

D Accent:
Acrylite Colorless 0A000 B0 textured acrylic panel, 0.125" thickness, cut to size. Rout grooves into face, no greater than 0.0625" configured to accept Bars. Polish returns clear, smooth and even, eliminating any tooling marks and backpaint at second surface. Laminate to Tactile Plaque using concealed adhesive sheeting, aligning edges.

E Backplate:
Acrylic sheet, 0.25" thickness, cut to size. Buff returns smooth and even to eliminate tooling marks. Paint finish all surfaces as indicated. Apply thin tin @name plate location only. Configured to hold name plate.

Installation:
Concealed 3M VHB tape & silicone mount flush to wall adjacent to latch side of door. Locate 58" to centerline of plaque from finished floor, 2" from door frame. At outswinging door locations maintain distance specified in DOJ 2010 ADA Standards for Accessible Design.

NOTE: Taken from DFW International Airport Headquarters document dated March 17, 2014

WARNING:

This record contains Sensitive Security Information that is controlled under 49 CFR parts 15 and 1520. No part of this record may be disclosed to persons with a "need to know," as defined in 49 CFR parts 15 and 1520, except with the written permission of the Administrator of the Transportation Security Administration or the Secretary of Transportation. Unauthorized release may result in civil penalty or other action. For U.S. government agencies, public disclosure is governed by 5 U.S.C. 552 and 49 CFR parts 15 and 1520.

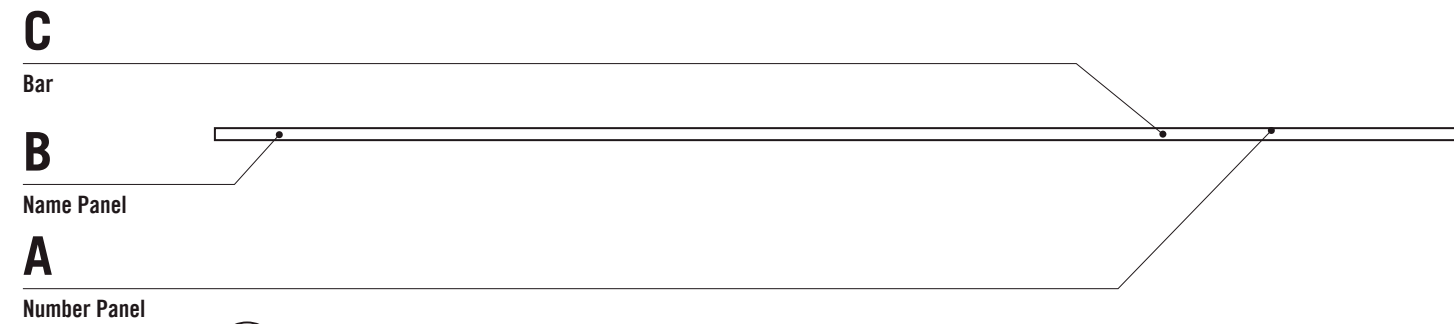

2 Top View / Half Size

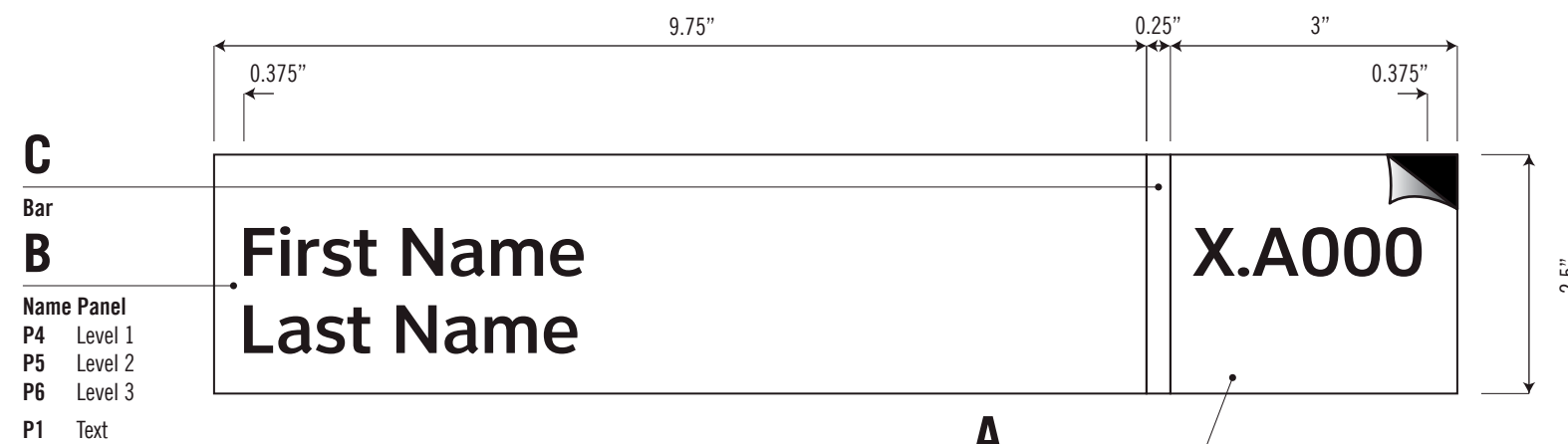

1 Elevation / Half Size

A
Number Plaque
 P4 Level 1
 P5 Level 2
 P6 Level 3
 P1 Text

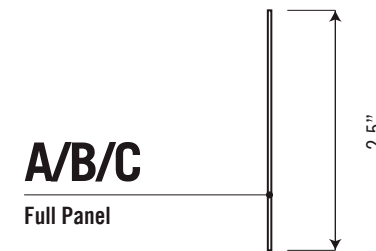

3 Elevation / Half Size

A Number Plaque:
 Acrylic plaque, 0.125" thickness, cut to size. Buff returns smooth and even to eliminate any tooling marks. Paint finish all surfaces as indicated. Screen print graphics to first surface.

Typography:
 Number: Clearview Text Medium, 0.625" Cap Height (Based on "E"); Interline spacing as indicated.

B Name Plate:
 Acrylic plaque, 0.125" thickness, w/ screen printed graphics. Buff returns smooth and even to eliminate tooling marks. Paint finish all surfaces as indicated. Held in place with concealed magnetic tape and sheet steel.

Typography:
 Name: Clearview Text Medium, 0.625" Cap Height (Based on "E"); Interline spacing as indicated.

C Bar:
 Print-area: 0.25" wide by 0.125" thick

A, B and C = printed as 1 panel

Installation:
 Install over existing cubicle wall. Sign fabricator to verify conditions prior to fabrication.

NOTE: Taken from DFW International Airport Headquarters document dated March 17, 2014

Dimensions & shapes of all elements as shown on G3.B11a.

A Tactile Plaque:
Photopolymer Plaque, 0.25" thickness, w/ raised graphics and Grade 2 Braille. Buff returns smooth and even to eliminate tooling marks. Paint finish all surfaces as indicated.

Typography:
Clearview Text Medium, 0.625" Cap Height (Based on "E"), Kerned +25%. Interline spacing as indicated.

Grade 2 Braille:
Height, kerning & leading per requirements of the DOJ's 2010 ADA Standards for Accessible Design.

B Accent:
Acrylite Colorless 0A000 B0 textured acrylic panel, 0.125" thickness, cut to size. Rout grooves into face, no greater than 0.0625" configured to accept Bars. Polish returns clear, smooth and even, eliminating any tooling marks and backpaint at second surface. Laminate to Tactile Plaque using concealed adhesive sheeting, aligning edges.

C Bars:
Aluminum Bars 0.25" wide by 0.125" thick with vertical brush finish, cut to length. Buff edges smooth and even to eliminate any tooling marks. Apply thin and even matte finish clearcoat to all surfaces and laminate to Accent with concealed adhesive.

Installation:
Concealed 3M VHB tape & silicone mount flush to wall adjacent to latch side of door. Locate 58" to centerline of plaque from finished floor, 2" from door frame. At outswinging door locations maintain distance specified in DOJ 2010 ADA Standards for Accessible Design.

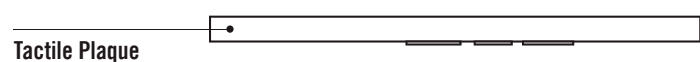

Tactile Plaque

2 Top View / Half Size

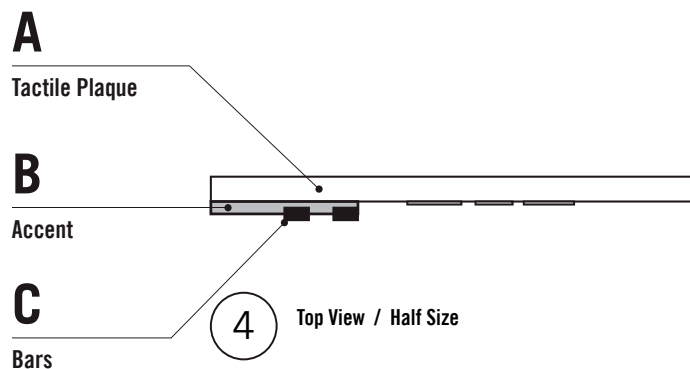

Tactile Plaque

Accent

Bars

4 Top View / Half Size

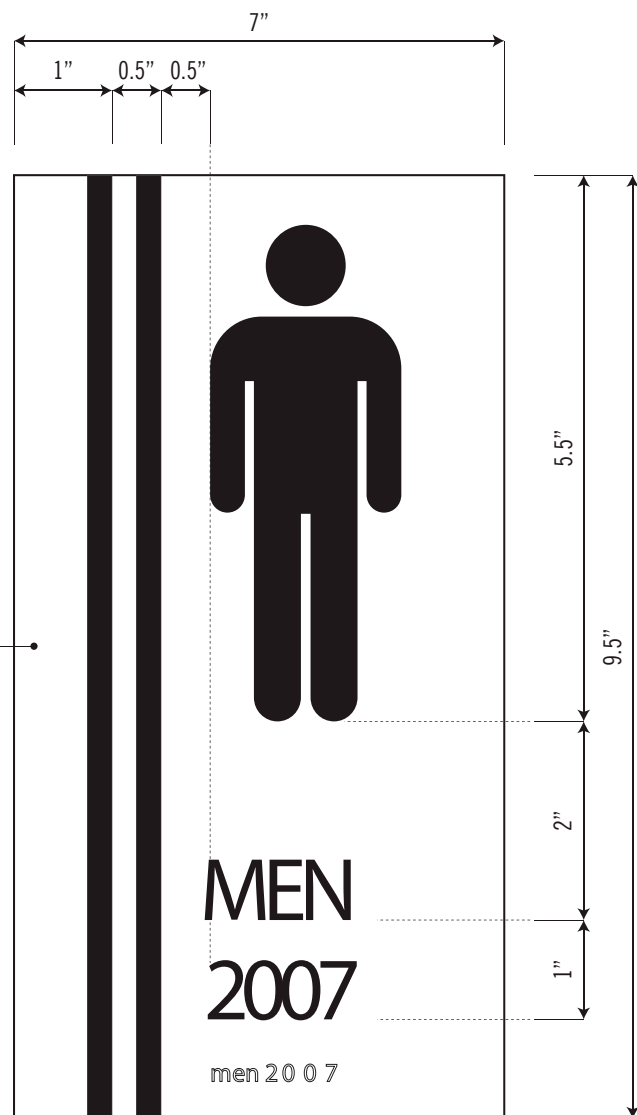

A
Tactile Plaque
All Surfaces
P4 Level 1
P5 Level 2
P6 Level 3
P1 Text & Symbol
P14 Bars

1 Elevation / Half Size
Style A

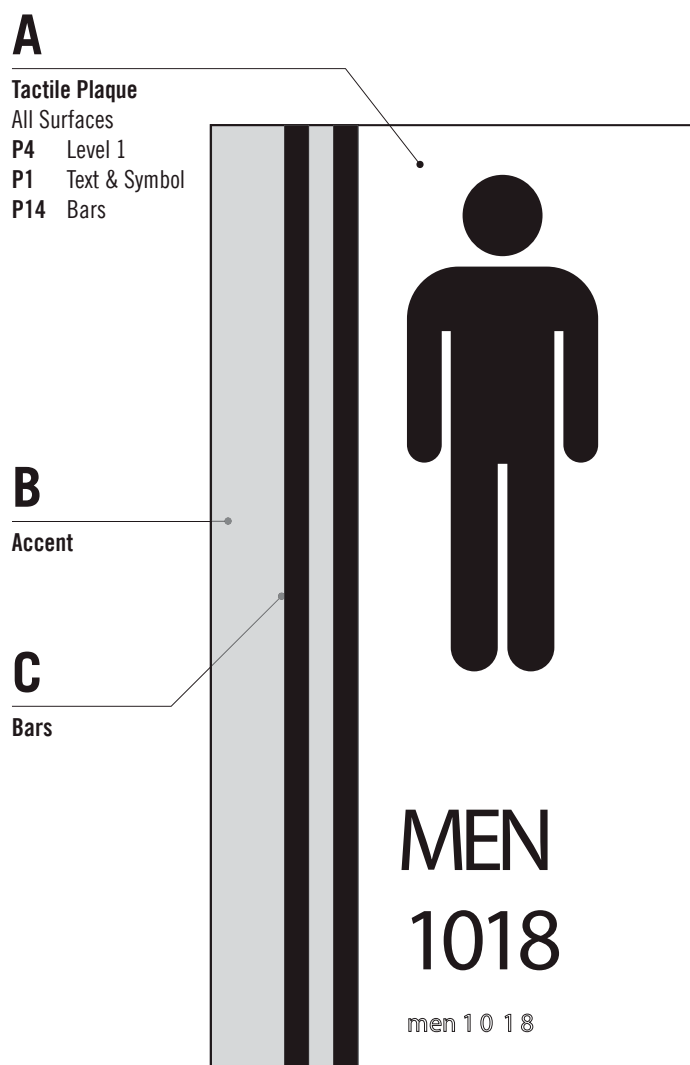

Tactile Plaque

All Surfaces
P4 Level 1
P1 Text & Symbol
P14 Bars

Accent

Bars

3 Elevation / Half Size
Style B

NOTE: Taken from DFW International Airport Headquarters document dated March 17, 2014

WARNING:

This record contains Sensitive Security Information that is controlled under 49 CFR parts 15 and 1520. No part of this record may be disclosed to persons with a "need to know," as defined in 49 CFR parts 15 and 1520, except with the written permission of the Administrator of the Transportation Security Administration or the Secretary of Transportation. Unauthorized release may result in civil penalty or other action. For U.S. government agencies, public disclosure is governed by 5 U.S.C. 552 and 49 CFR parts 15 and 1520.

Dimensions & shapes of all elements as shown on G3.B12a thru G3.12d.

A Vinyl:
3M Computer-cut Vinyl. 1st Surface application. Color as indicated. Vinyl to be applied on both sides of glass panels. Designer to provide artwork for prior to fabrication.

Installation:
Clean surface & apply Vinyl. Sign contractor to verify all as-built conditions prior to fabrication including dimensions and indicate on shop drawings. Ensure that all elements are uniform, parallel and aligned.

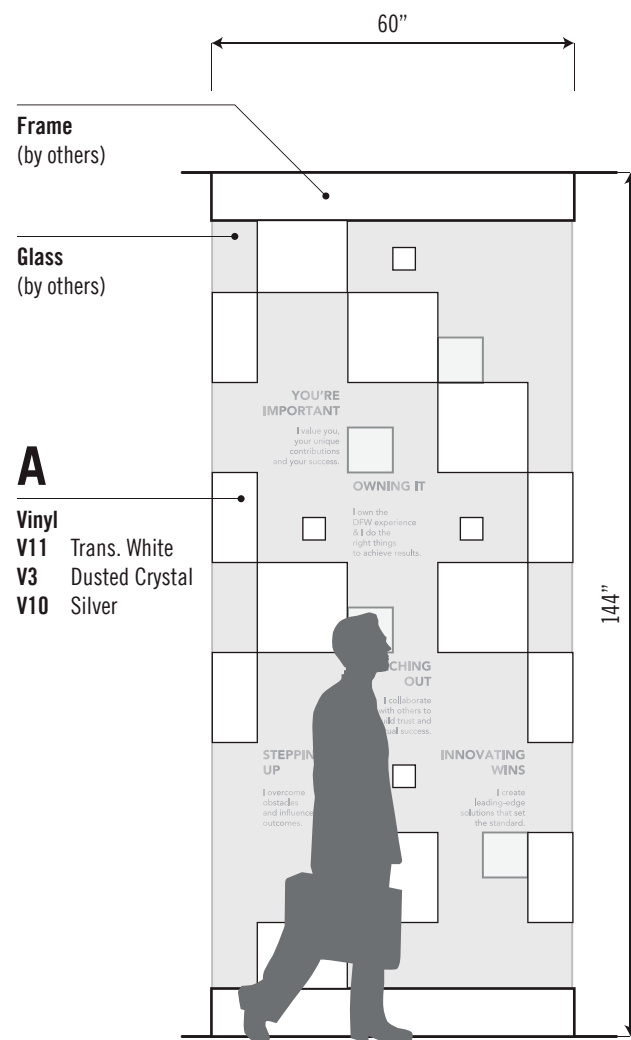

1 Elevation / 3/8" = 1' - 0"
Lounge Panel 1, Side A Shown



Silver Elements

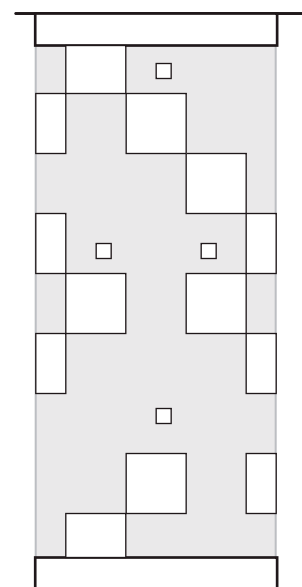

White Elements

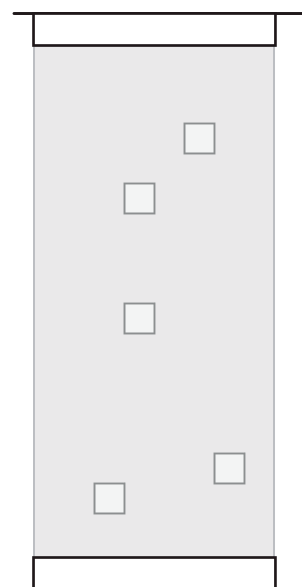

Dusted Crystal Elements

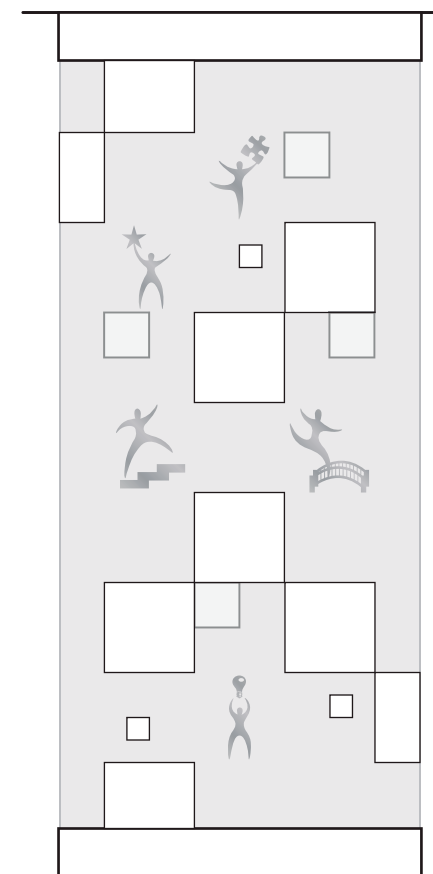

2 Elevation / 3/8" = 1' - 0"
Lounge Panel 1, Side B Shown

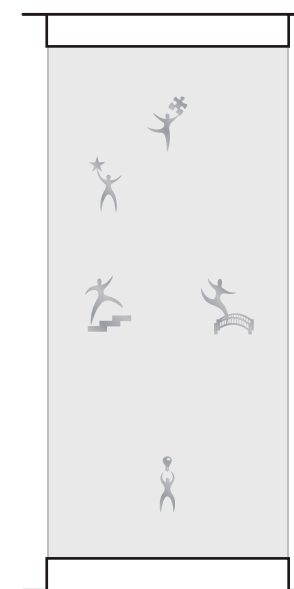

Silver Elements

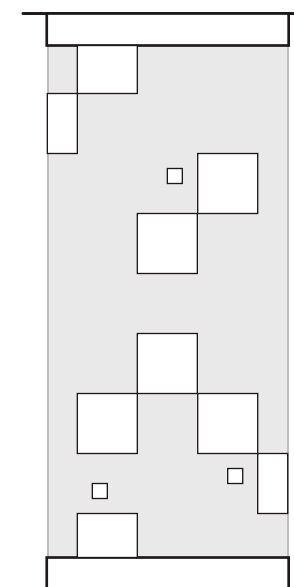

White Elements

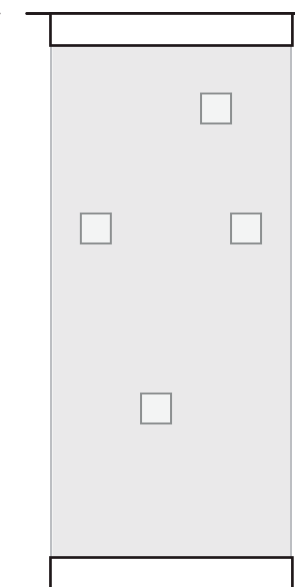

Dusted Crystal Elements

NOTE: Taken from DFW International Airport Headquarters document dated March 17, 2014

WARNING:

This record contains Sensitive Security Information that is controlled under 49 CFR parts 15 and 1520. No part of this record may be disclosed to persons with a "need to know," as defined in 49 CFR parts 15 and 1520, except with the written permission of the Administrator of the Transportation Security Administration or the Secretary of Transportation. Unauthorized release may result in civil penalty or other action. For U.S. government agencies, public disclosure is governed by 5 U.S.C. 552 and 49 CFR parts 15 and 1520.

Dimensions & shapes of all elements as shown on G3.B12a thru G3.12d.



NOTE: Taken from DFW International Airport Headquarters document dated March 17, 2014

Dimensions & shapes of all elements as shown on G3.B12a thru G3.12d.

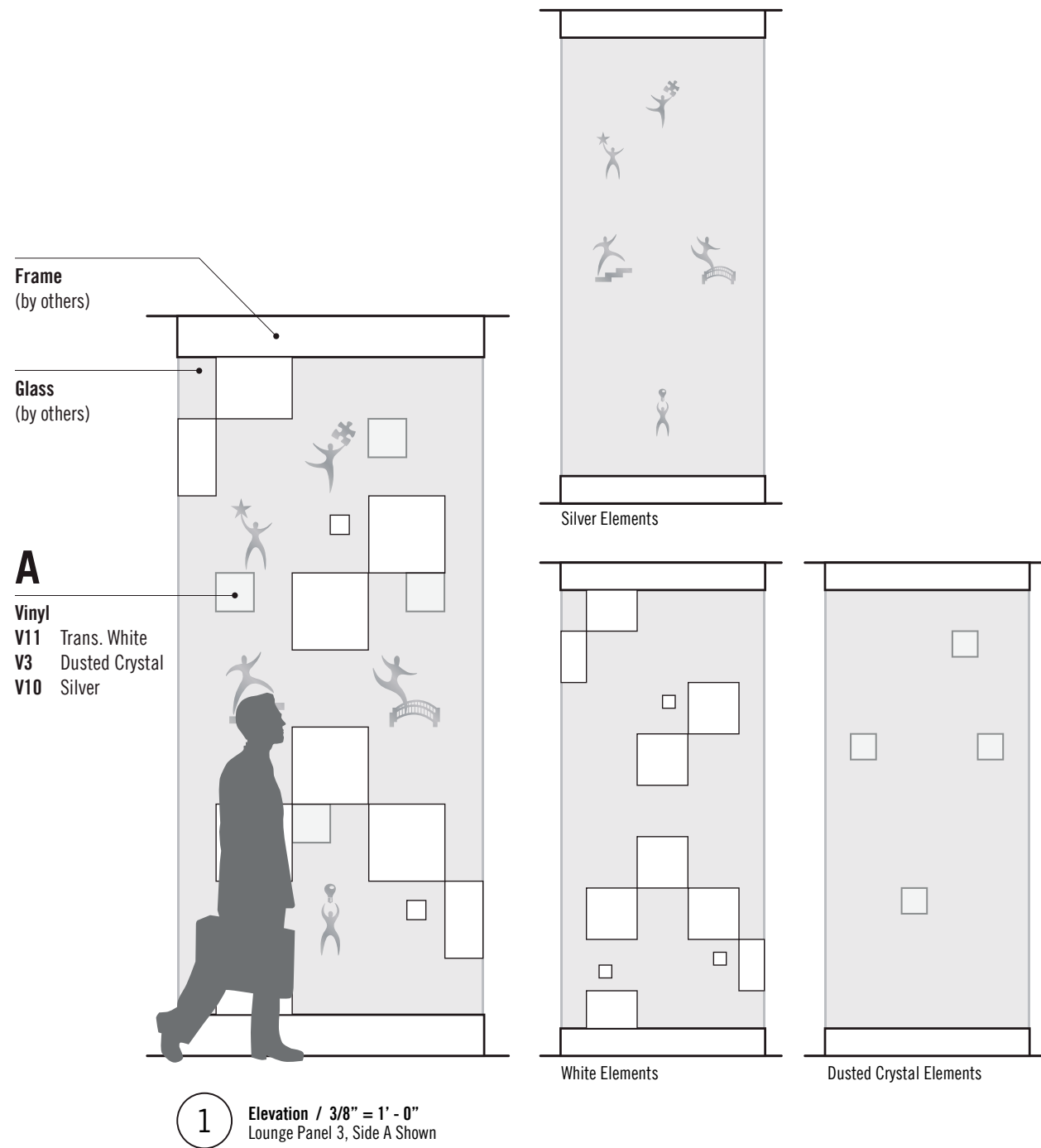

NOTE: Taken from DFW International Airport Headquarters document dated March 17, 2014

Dimensions & shapes of all elements as shown on G3.B12a thru G3.12d.

- Frame (by others)
- Glass (by others)
- A**
- Vinyl
- V11 Trans. White
- V3 Dusted Crystal
- V10 Silver

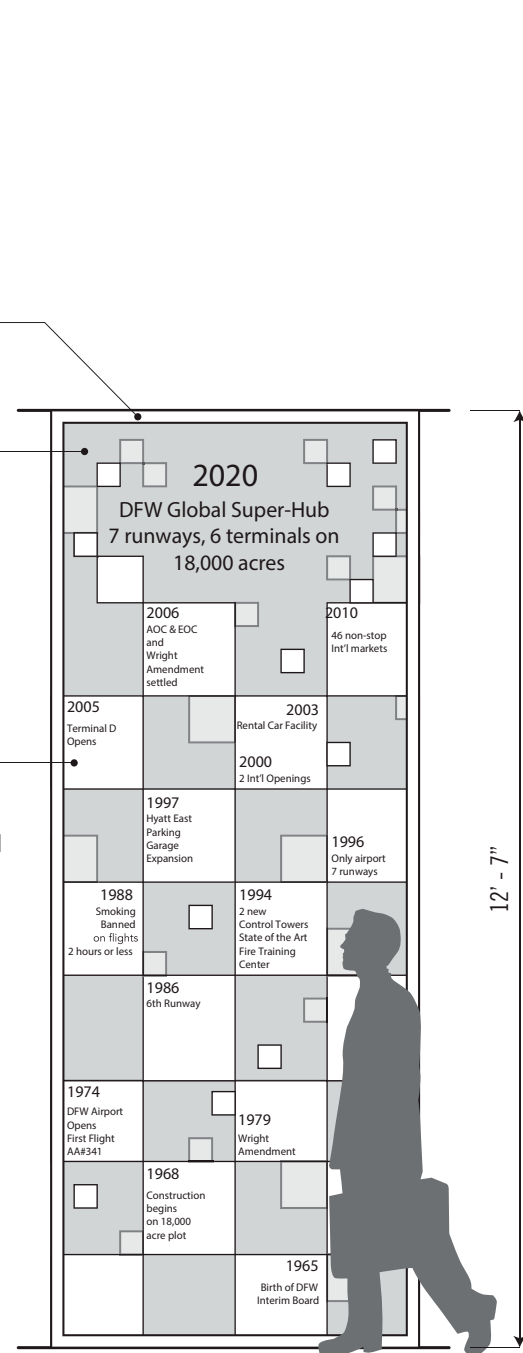

1 Elevation / 3/8" = 1' - 0" History Wall, Shown

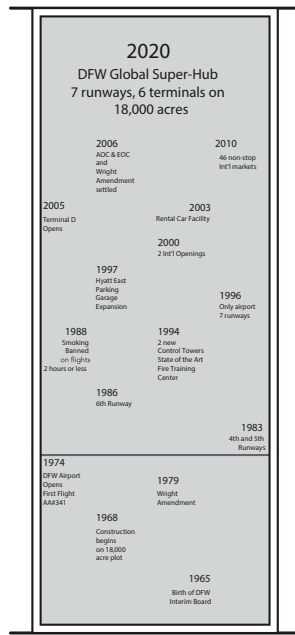

Silver Elements

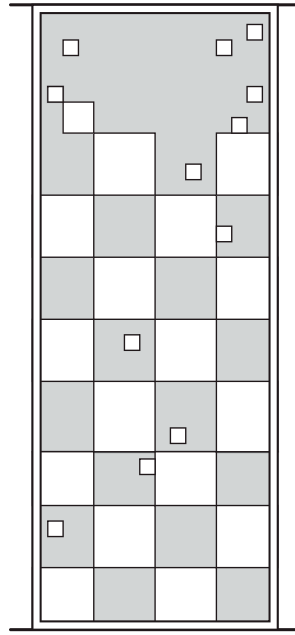

White Elements

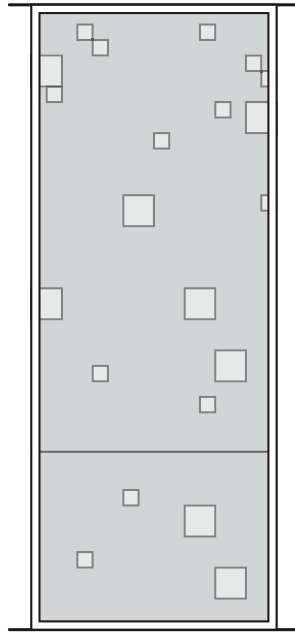

Dusted Crystal Elements

- Frame (by others)
- Glass (by others)
- A**
- Vinyl
- V11 Trans. White
- V3 Dusted Crystal
- V10 Silver

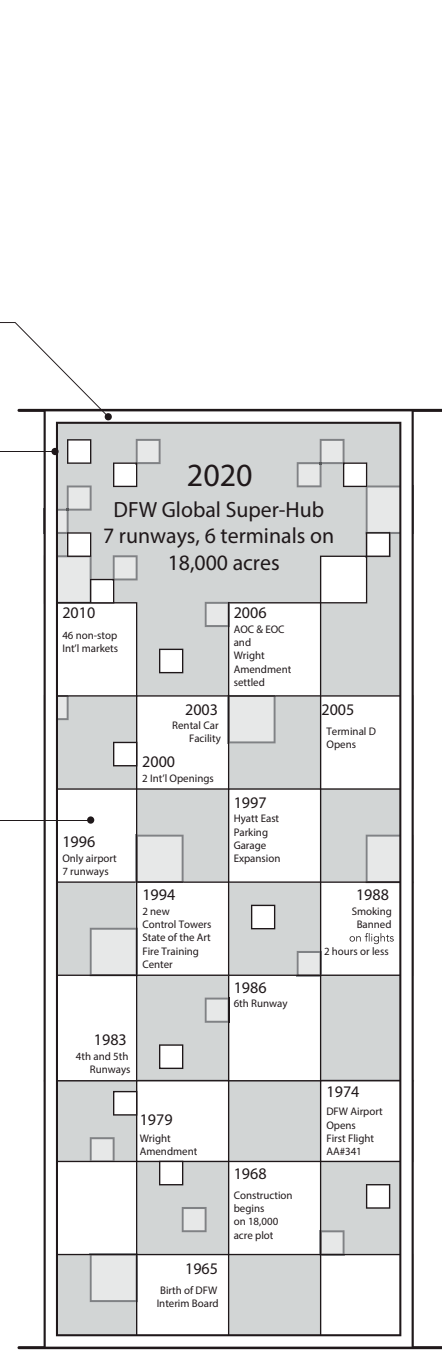

2 Elevation / 3/8" = 1' - 0" History Wall, Shown

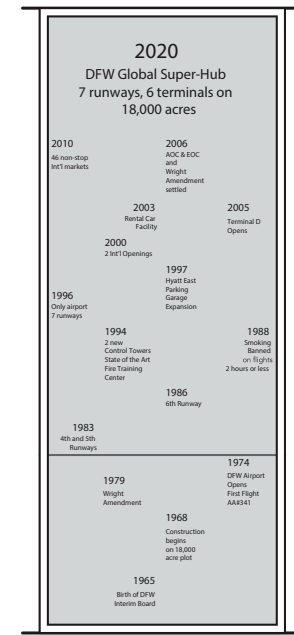

Silver Elements

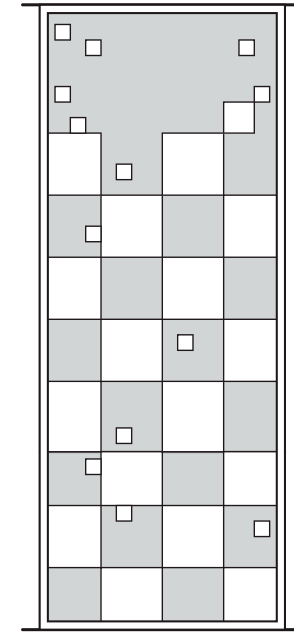

White Elements

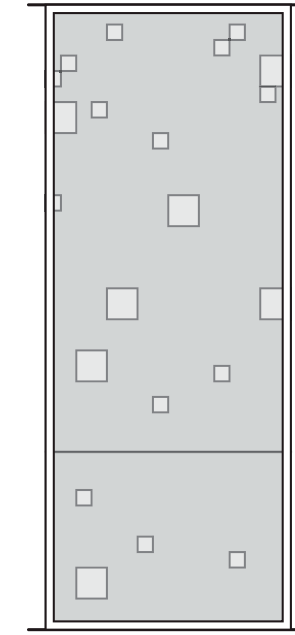

Dusted Crystal Elements

NOTE: Taken from DFW International Airport Headquarters document dated March 17, 2014

Dimensions & shapes of all elements as shown on G3.B14a.

A Panel:
Acrylic plate of 0.125" thickness, cut to size. Buff returns smooth and even to eliminate any tooling marks. Paint all surfaces as indicated. Graphics to be screened first surface.

Typography:
Messages: Clearview Hwy 3-W, 1" Cap Height (Based on "E"), Interline spacing as indicated. Kerned -50%.
Numeral: Clearview Hwy 5-W, 5" Cap Height (Based on "E").

Symbols:
Arrow: 3" Height; Star: 3" Height

B Tactile Plaque:
Photopolymer Plaque, 0.0625" thickness, w/ raised graphics and Grade 2 Braille. Buff returns smooth and even to eliminate tooling marks. Paint finish all surfaces as indicated. Laminate to panel with concealed adhesive, align edges.

Typography:
Clearview Text Bold, 0.625" Cap Height (Based on "E").

Grade 2 Braille:
Height, kerning & leading per requirements of the DOJ's 2010 ADA Standards for Accessible Design.

Installation:
Concealed VHB tape & silicone mount holder assembly flush to wall at 56" above finish floor to bottom of sign. Locate on wall outside stair where sign is visible. Owner to field verify position.

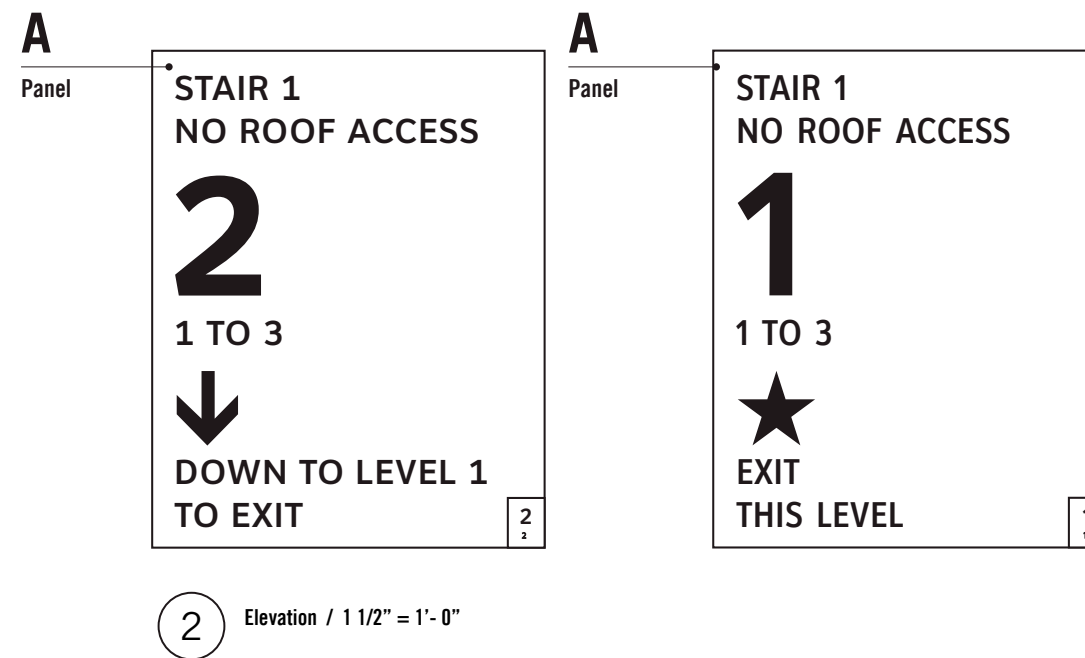
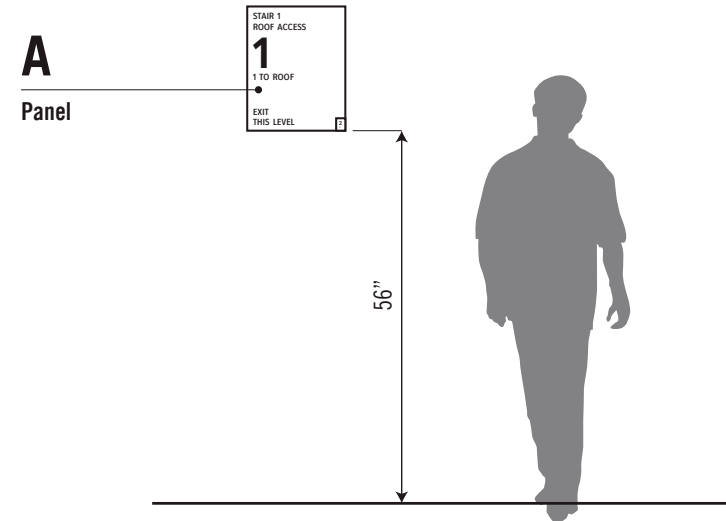
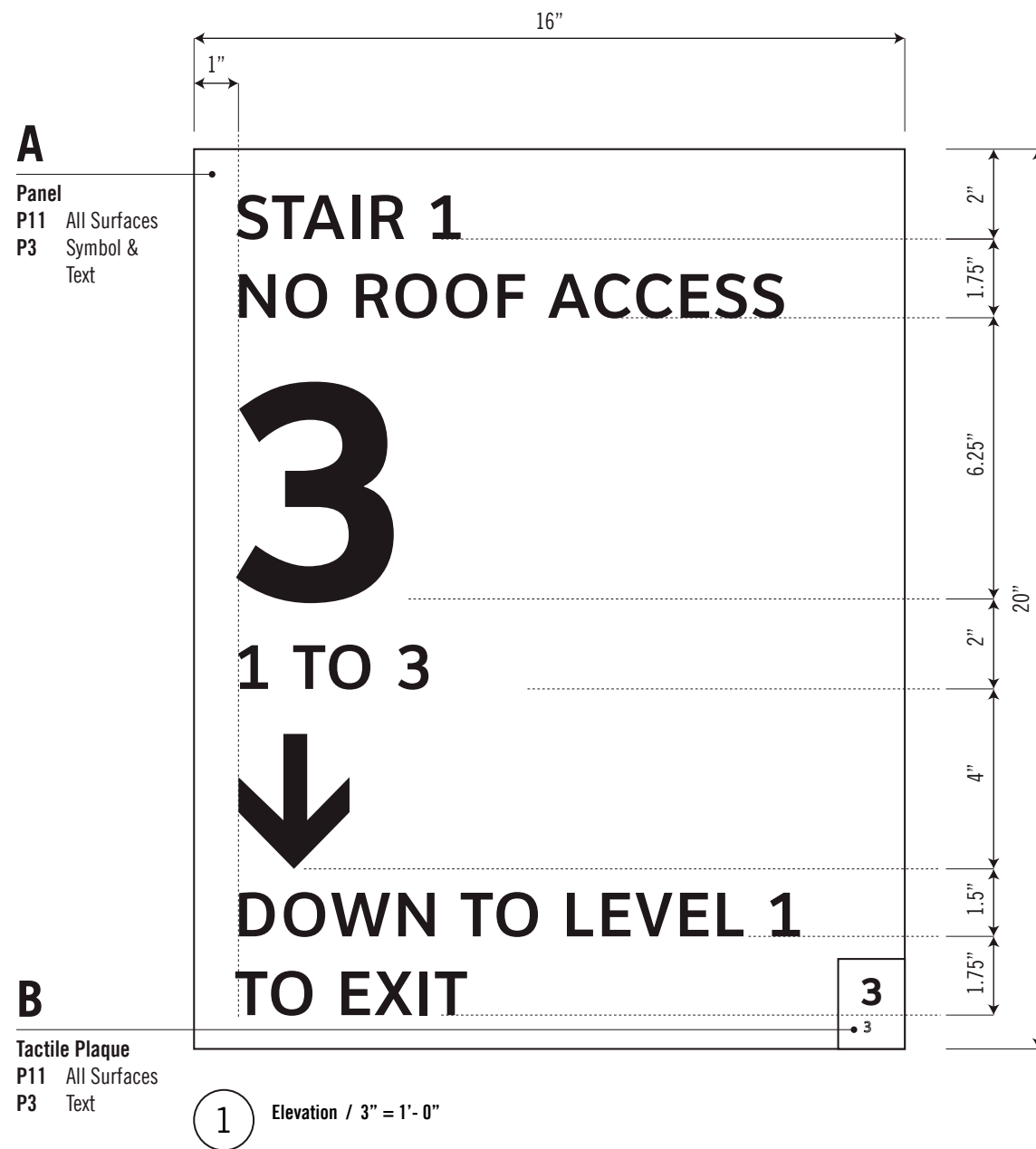

NOTE: Taken from DFW International Airport Headquarters document dated March 17, 2014

Dimensions & shapes of all elements as shown on G3.B15a.

A Panel:

0.125" Thick acrylic, cut to size. Buff returns smooth and even to eliminate tool marks. Paint all surfaces as indicated. Graphics to be screened first surface.

Typography:

For "Flight Level": Clearview Text Book, 1" Cap Height (Based on "E"), Kerned -25%. For Level Indicator: Clearview Text Bold, 1.5" Cap Height (Based on "1"), Kerned -50%. For Map Key & Warning Information: Clearview Text Book, 0.5" Cap Height (Based on "E"), Interline spacing as indicated. For "In Case of Fire...": Clearview Text Bold, 0.625" Cap Height (Based on "E"), Kerned 0. Interline spacing as indicated.

Symbols:

(FS): 2.5" Height, (FES): 0.5" Height, (YAH): 0.5" Height, (SR): 0.5" Height, (RR): 0.5" Height

Map Art:

Signage Contractor is responsible for developing ALL map layouts, including determination of primary and secondary paths of egress based on Life Safety Plans (A1 Series), and is responsible for producing ALL digital artwork required to produce signage. Submit ALL finished map artwork to Designer for review and approval of map style and content. Submit ALL finished map artwork to project Fire Marshall and/or other appropriate governing agency within the project jurisdiction for review and approval for fire code compliance. Provide hard copy of Fire Marshall's signed approval to Owner for record keeping. Refer to sheet G3.MSa for map style guide and minimal requirements for map art.

Installation:

Concealed 3M VHB tape and silicone mount flush to wall 1 1/2" above existing elevator call button plate. Designer verify and confirm location in field.

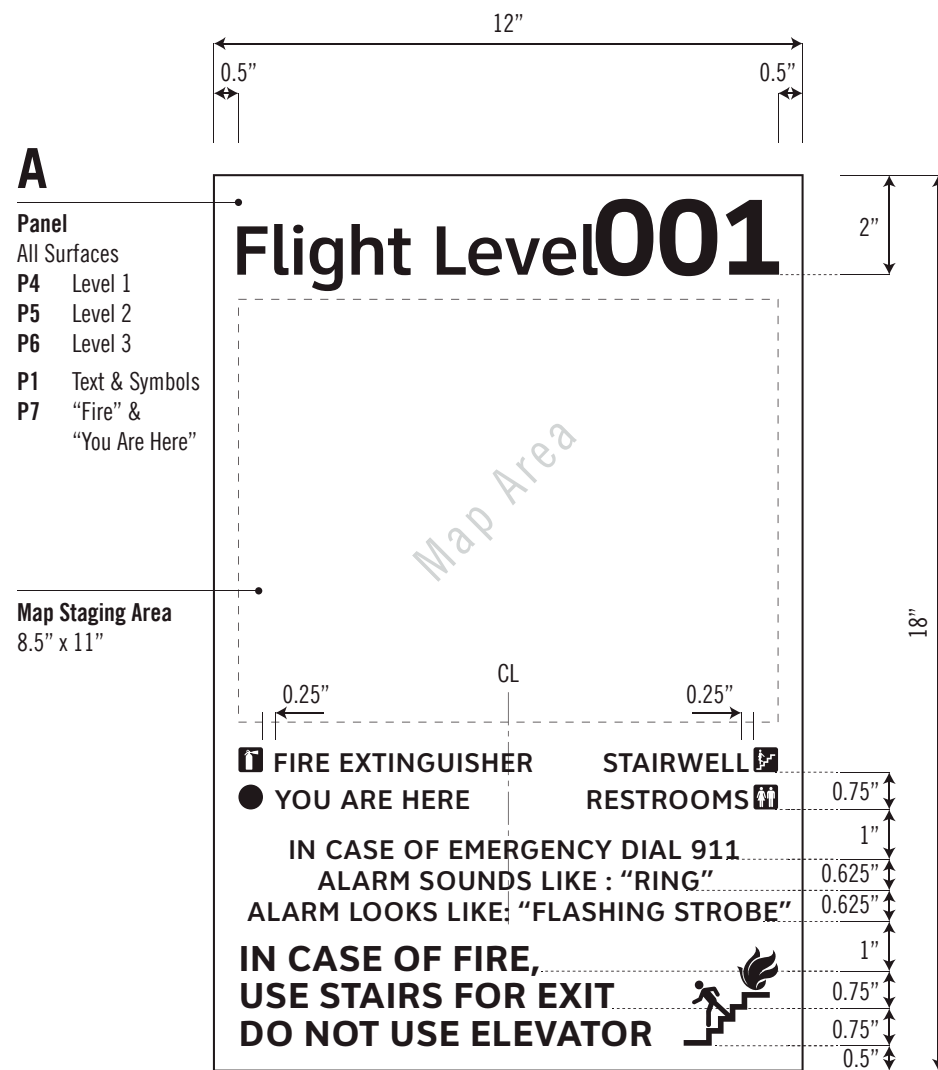

1 Elevation / 3" = 1'-0"

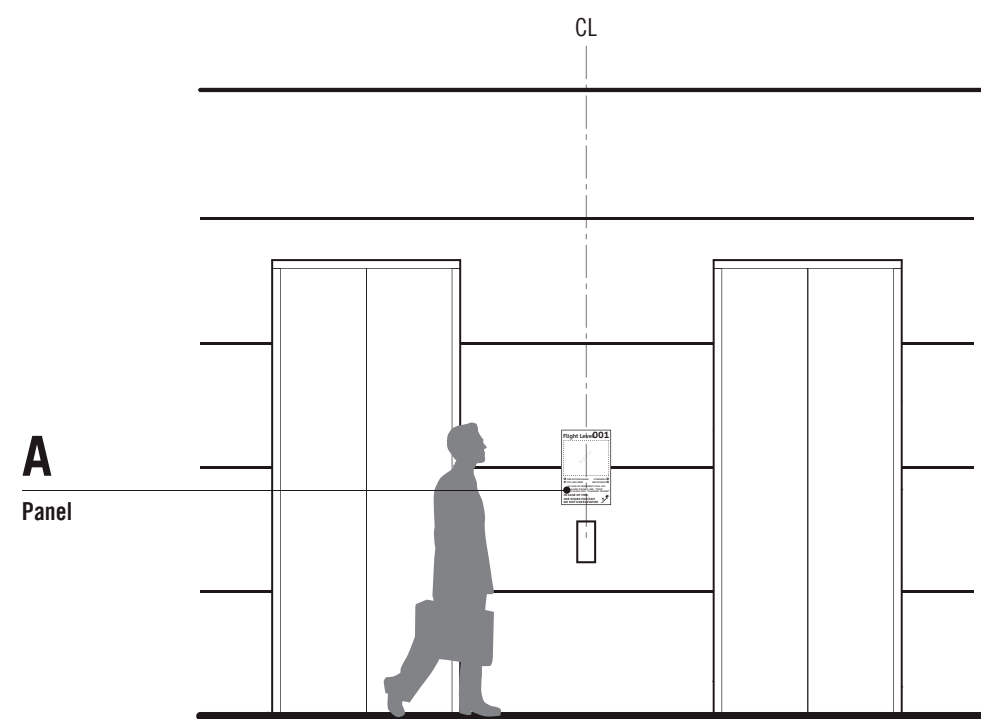

2 Elevation / 1/4" = 1'-0"

NOTE: Taken from DFW International Airport Headquarters document dated March 17, 2014

WARNING:

This record contains Sensitive Security Information that is controlled under 49 CFR parts 15 and 1520. No part of this record may be disclosed to persons with a "need to know," as defined in 49 CFR parts 15 and 1520, except with the written permission of the Administrator of the Transportation Security Administration or the Secretary of Transportation. Unauthorized release may result in civil penalty or other action. For U.S. government agencies, public disclosure is governed by 5 U.S.C. 552 and 49 CFR parts 15 and 1520.

Dimensions & shapes of all elements as shown on G3.B16a.

A Holder:
Two layers of 0.125" Colorless Non-Glare Acrylic w/ 0.0625" Acrylic spacer. Open @ both left and right sides. Configure to hold Insert and removable with Post-It note. Back paint 2nd surface of front layer to create window. Back with spacer and backer. Clear polish returns of front plate only. Buff returns of spacer and backer and paint all surfaces as indicated (Note: Front of backer is paint finished). Laminate all parts together with concealed full sheet adhesive.

B Insert:
Clear Rigid Acetate with computer printed map art as indicated. Insert to fit flush at sides of opening.

Map Art:
Signage Contractor is responsible for developing All map layouts, including determination of primary & secondary paths of egress based on Life Safety plans (A1 Series); and, is responsible for producing ALL digital and/or hard copy camera-ready artwork required to produce signage. Submit ALL finished map artwork to Designer for design intent review & submit to project Fire Marshall and/or other appropriate governing agency within the project jurisdiction for review & approval for fire code compliance. Provide hard copy of Fire Marshall's signed approval to Owner, Designer & Architect for record keeping. Designer to provide map style guide w/ list of minimum requirements, sign location plans ONLY.

Installation:
Concealed VHB tape & silicone mount flush to wall. Locate 56" from center of sign to finished floor. Designer / Fire Marshall to confirm mounting location of extra stock as required.

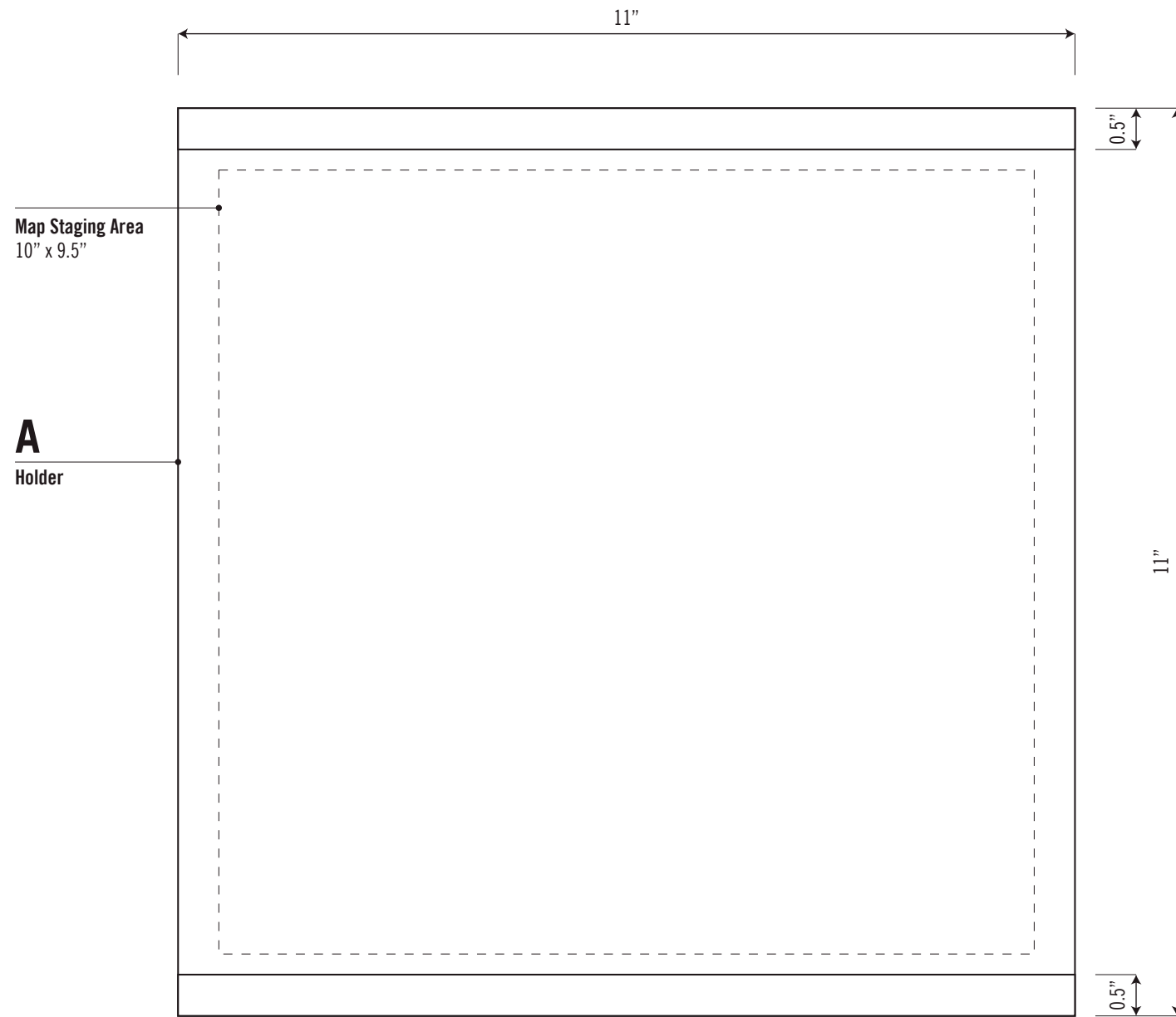

1 Elevation / Half Size

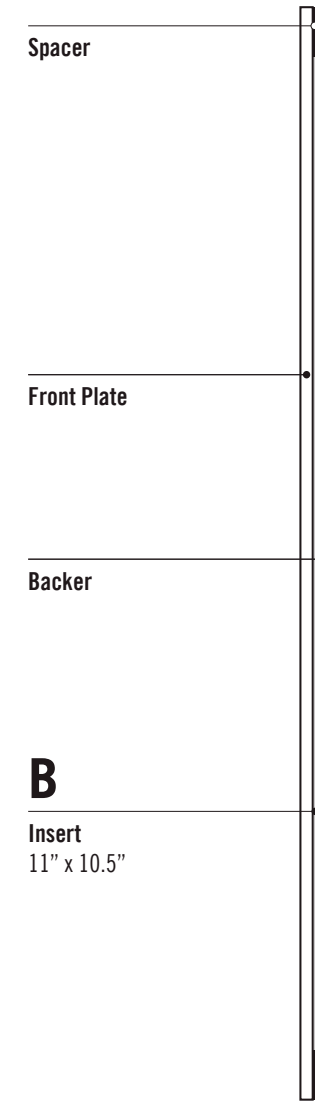

2 Side View / Half Size

NOTE: Taken from DFW International Airport Headquarters document dated March 17, 2014

Dimensions & shapes of all elements as shown on G3.B17a.

A Cut Letters:
Computer Cut 0.25" aluminum letters. Grind and buff smooth to eliminate any tooling marks. Paint all surfaces as indicated.

Typography:
For "Flight Level", Clearview Text Book. For Level, Clearview Text Bold. Sized as indicated.

Installation:
Concealed 3M VHB tape & silicone mount flush to wall. locate as indicated.

A
Cut Letters
P1 All Surfaces

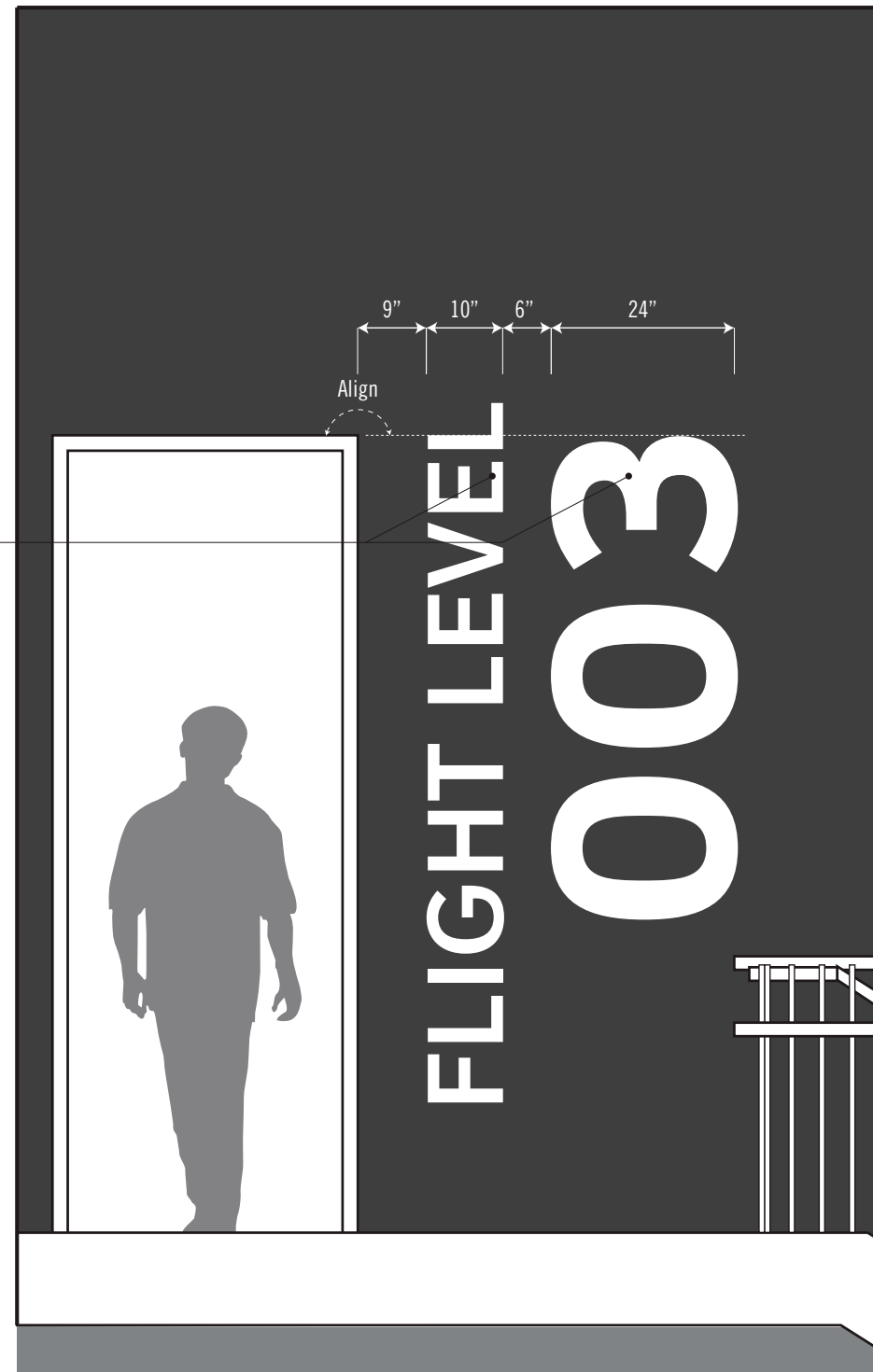

1 Elevation / 1/2" = 1'-0"

A
Cut Letters

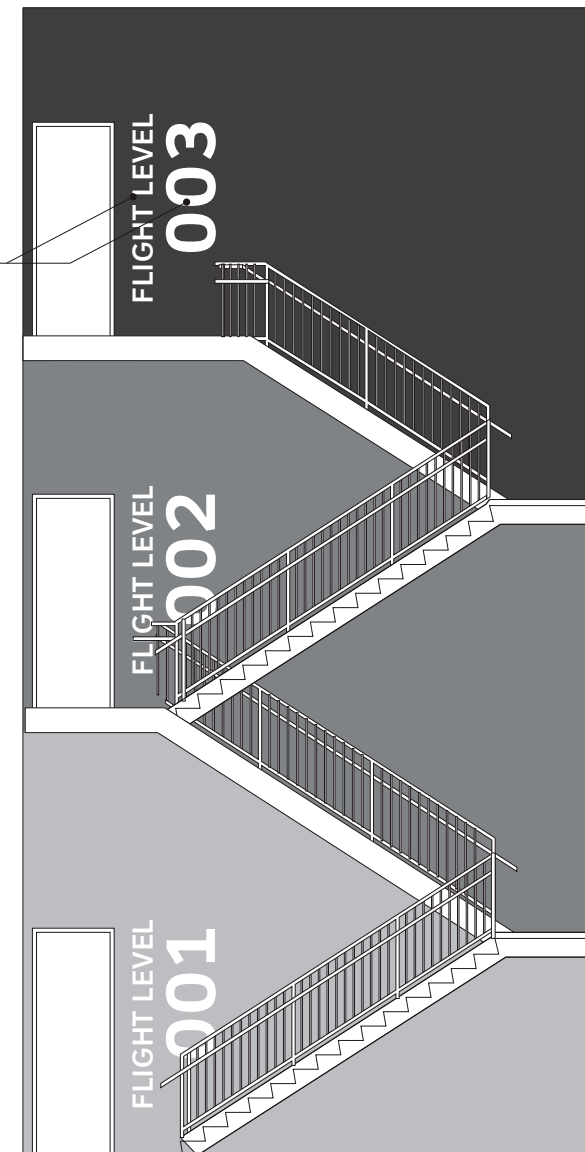

2 Elevation / 3/16" = 1'-0"

NOTE: Taken from DFW International Airport Headquarters document dated March 17, 2014

Dimensions & shapes of all elements as shown on G3.G18a.

A Panel:
Acrylic Plaque of 0.125" thickness. Cut to size and buff returns smooth and even to eliminate tooling marks. Paint finish all surfaces as indicated. screen print graphics at first surface.

Installation:
Concealed VHB tape & silicone mount holder assembly flush to wall. Locate on wall, 4" above Fire Extinguisher Cabinet. Owner to field verify position.

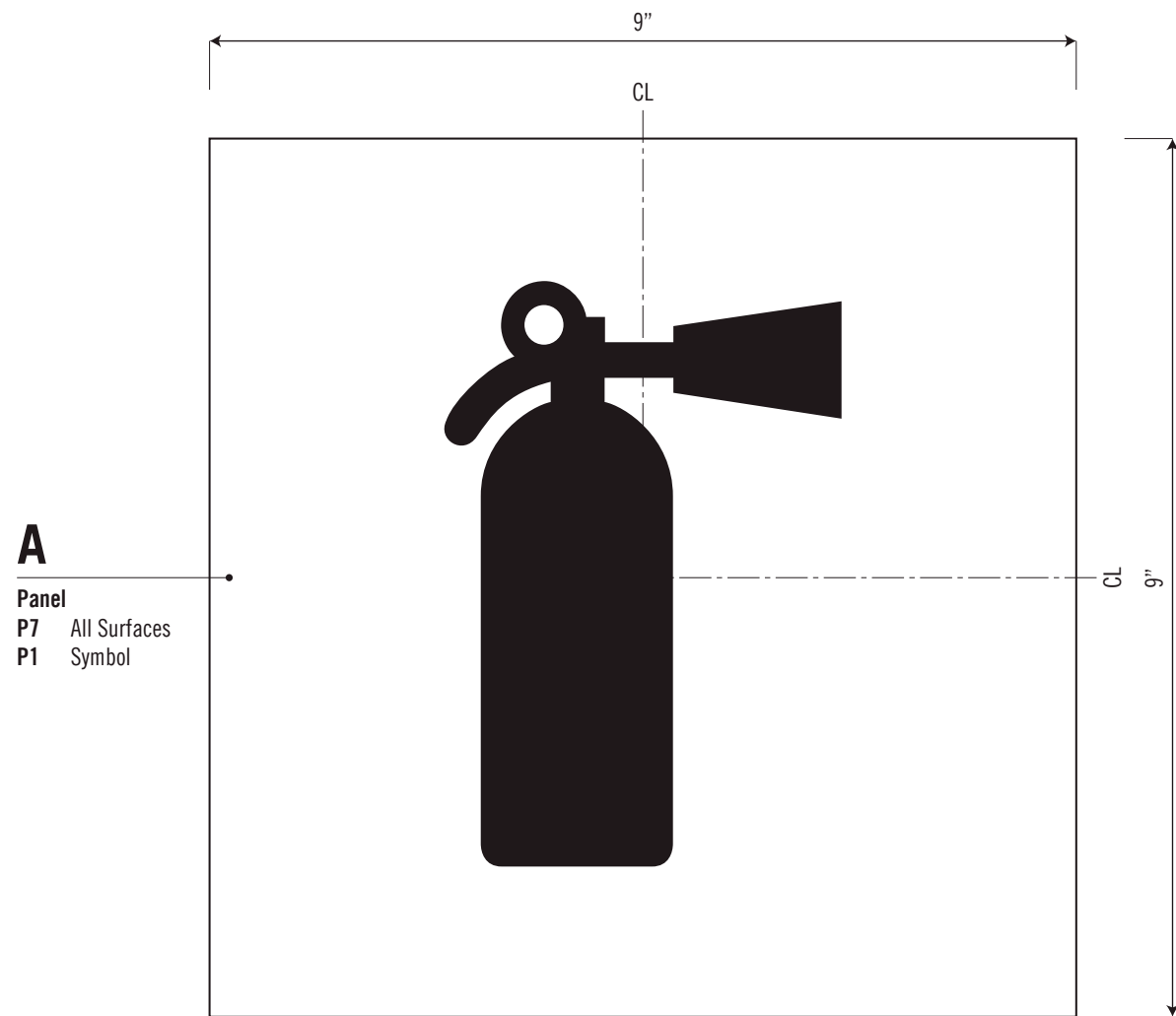

A
Panel
P7 All Surfaces
P1 Symbol

1 Elevation / Half Size Schematic

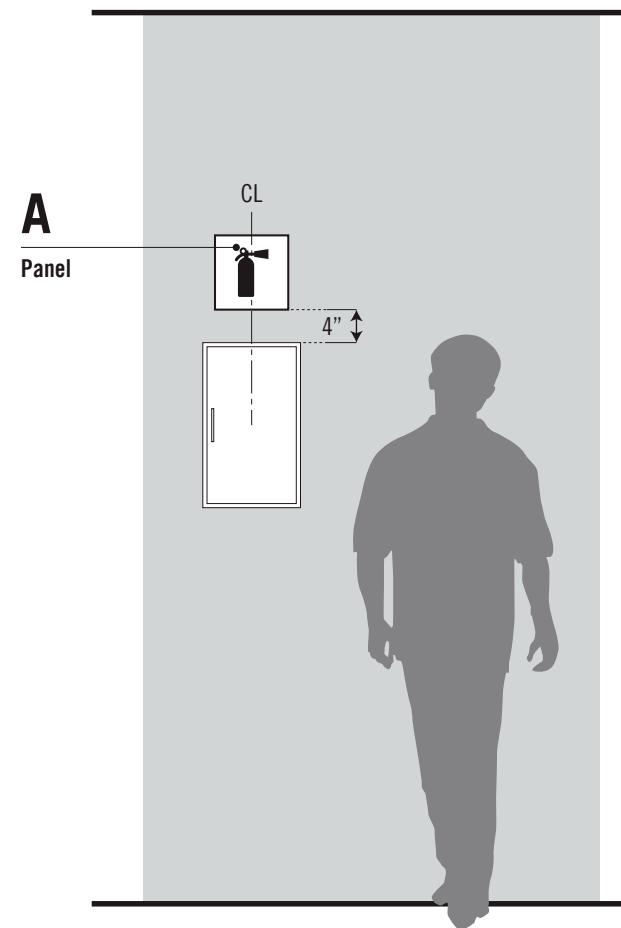

2 Elevation / 1/2" = 1'- 0"

NOTE: Taken from DFW International Airport Headquarters document dated March 17, 2014

Dimensions & shapes of all elements as shown on G3.B19a.

A Panel:
Acrylic sheet of 0.25" thickness, cut to size. Buff returns smooth and even to eliminate any tooling marks. Paint all surfaces as indicated and direct image gradient logo to first surface.

Installation:
Concealed VHB tape and silicone mount flush to lecturn. Locate as indicated.

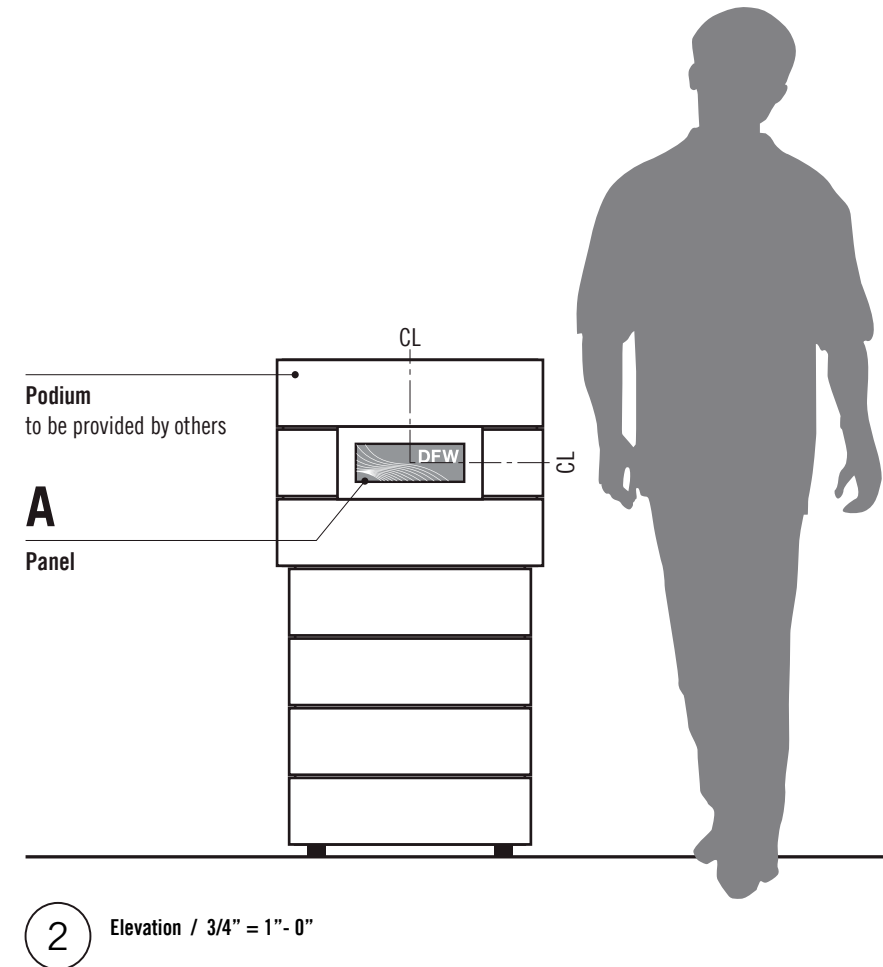
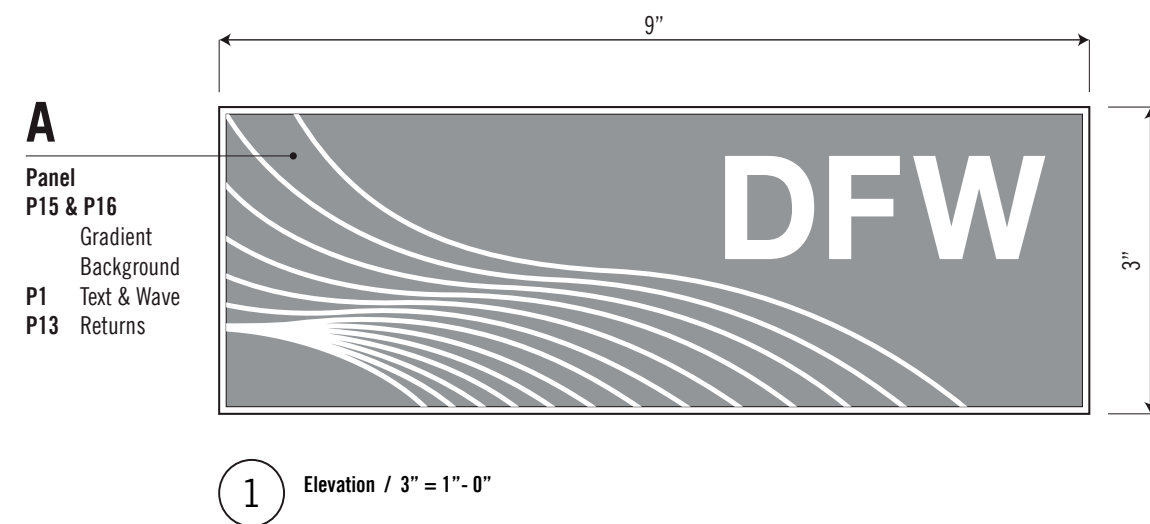

NOTE: Taken from DFW International Airport Headquarters document dated March 17, 2014

Dimensions & shapes of all elements as shown on G3.B20a.

A Panel:
Stainless steel panel of 0.090" thickness to be cut to shape. Buff edges smooth and even to eliminate any tooling marks. Roll face to match radius as indicated. Finish all surfaces as indicated. Name to be screen printed to first surface, color as indicated.

Typography:
Clearview Text Bold, 1.25" Cap Height (Based on "E"), Kerned 0.

Installation:
Sign assembly to be mounted to board member desk via incorporated mounting tabs and lip in desk. Sign Contractor responsible to field verify all as-built conditions prior to fabrication.

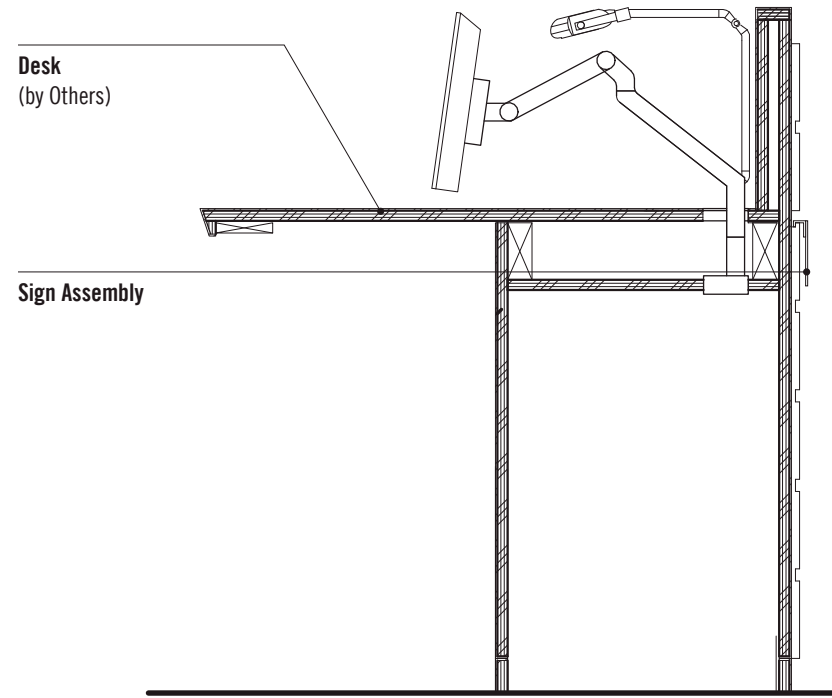

4 Mounting Detail / 3" = 1' - 0"



3 Top View / 3" = 1' - 0"

A
Panel

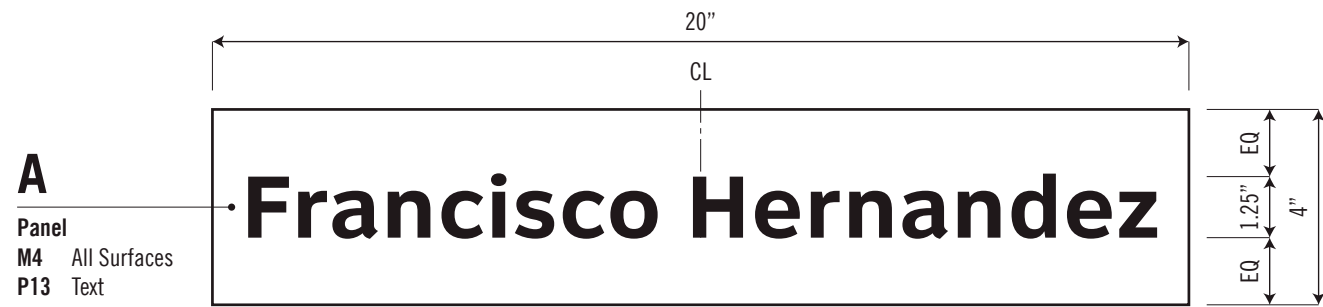

1 Elevation / 3" = 1' - 0"

A
Panel
M4 All Surfaces
P13 Text

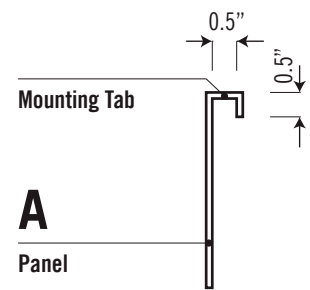

2 Side View / NTS

A
Panel

NOTE: Taken from DFW International Airport Headquarters document dated March 17, 2014

Dimensions & shapes of all elements as shown on G3.E2a.

A Panel:
Four panels required per location. Aluminum Panel of not less than 0.125" thickness. Cut to size and buff returns smooth and even to eliminate tooling marks. Paint finish all surfaces as indicated. Apply 3M Computer Cut Vinyl Graphics to first surface. Screen print logo to first surface as indicated.

Typography:
Clearview Hwy 4-W, 2.5" Cap Height (Based on "E"), Kerned -50%. Interline spacing of 6". For "DFW Airport Headquarters Clearview Hwy 3-W, 2" Cap Height (Based on "E"), Kerned 0. Interline spacing at 3.5"

Symbols:
Arrow: 3" Length; Logo: 6" Height; Rule = 0.25" thickness

B Base:
Cast in Place Smooth Finish Concrete, refer to Architect's specifications for concrete requirements to follow.

C Footing:
Single unit smooth finish concrete and rebar footing, sized and configured to support sign assembly plumb and level. Integrated smooth finish mow strip, sized as indicated.

Installation:
Concealed 3M VHB ape and construction adhesive flush to concrete base. Align Edges.

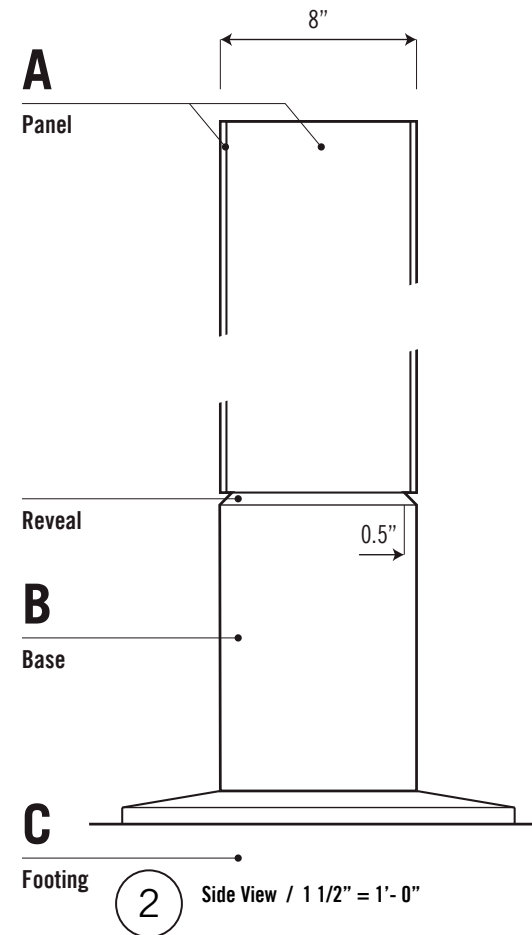
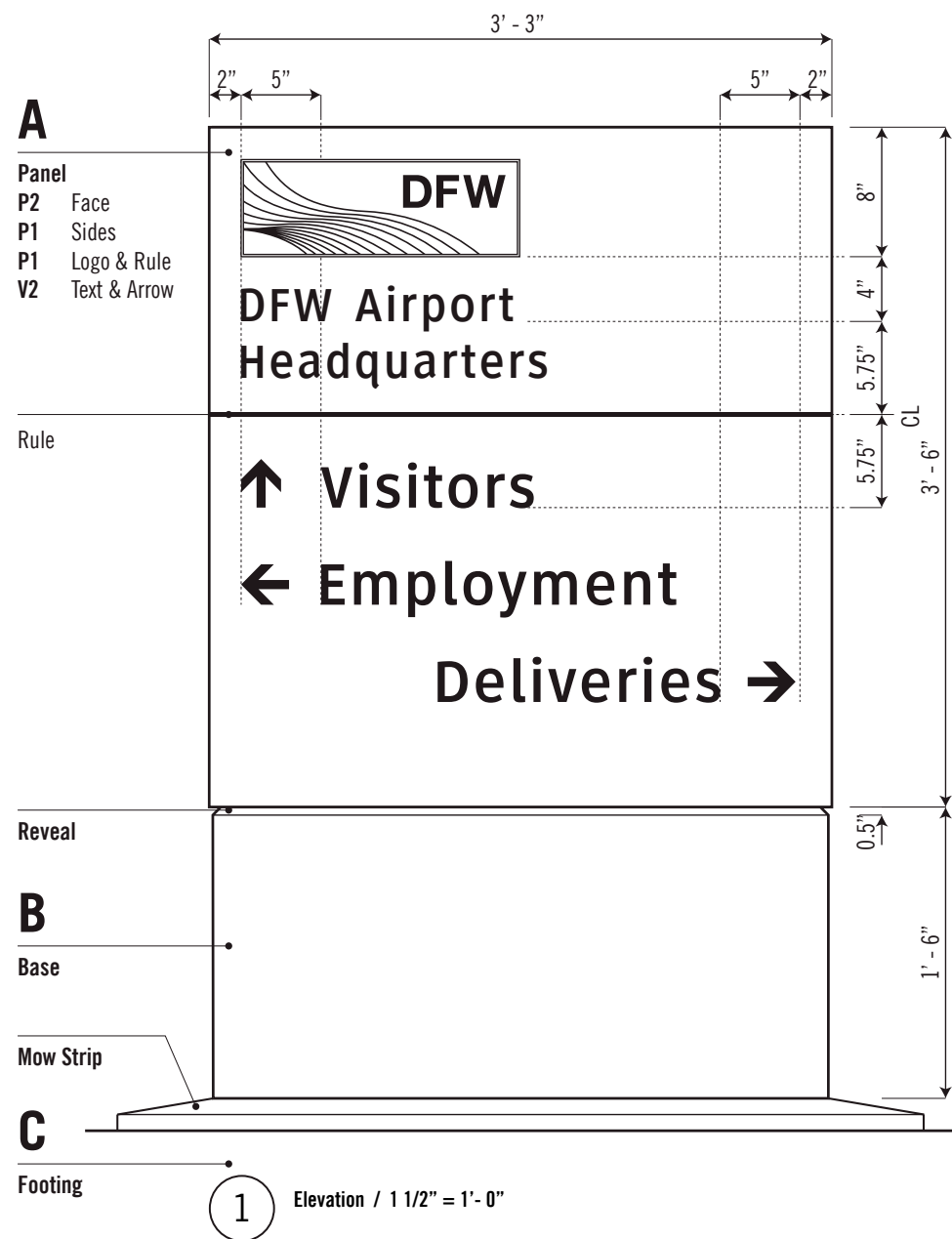
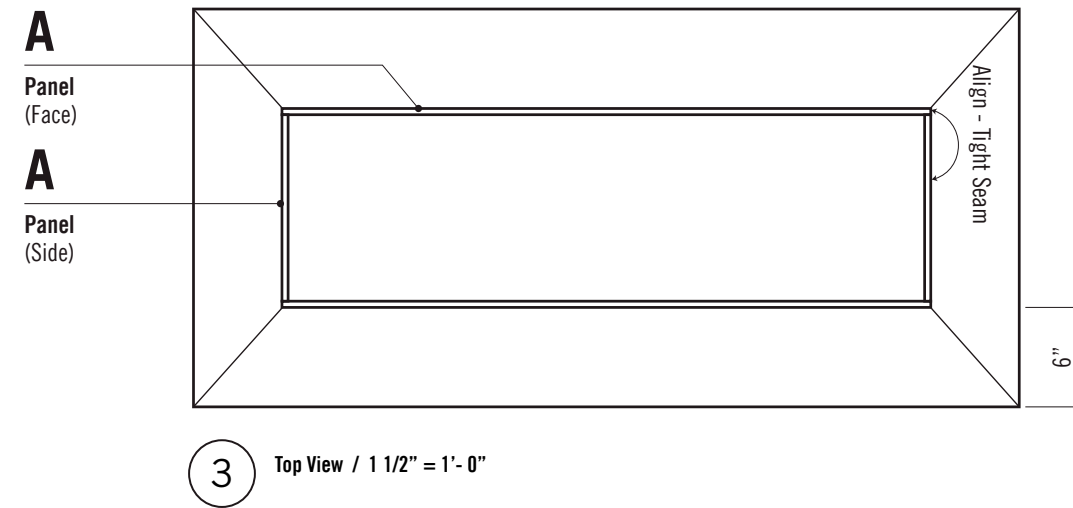

NOTE: Taken from DFW International Airport Headquarters document dated March 17, 2014

Dimensions & shapes of all elements as shown on G3.E3a thru G3.E3b.

A Panel:
 Aluminum Panel of 0.090" thickness. Cut to shape and buff returns smooth and even to eliminate tooling marks. Apply 3M Computer Cut Vinyl Graphics to first surface. Mount to post - post to be provided by others. Reference Architectural Documents for post details.

Typography
 For "Reserved Parking", Clearview Hwy 2-W, 1.75" Cap Height (Based on "E"), Interline Spacing of 2.5". For "Tow-Away" and "Van", Clearview Hwy 2-B, 1.5" Cap Height (Based on "E"). For "Zone" and "Accessible", Clearview Hwy 5-W, 1" Cap Height (Based on "E").

Symbols:
 (HC) = 8" height; Fuel Efficient Car = 5" Height
 Rule = 0.25" thickness

Installation:
 Direct Burial of Post and Panel assembly securely, level and plumb in below grade concrete footing. For softscape locations, back fill with soil and resod or match existing landscape materials. For hardscape locations, core drill and smooth concrete flush with surrounding surfaces. Sign contractor responsible to field verify all as build conditions to determine hardscape or softscape.

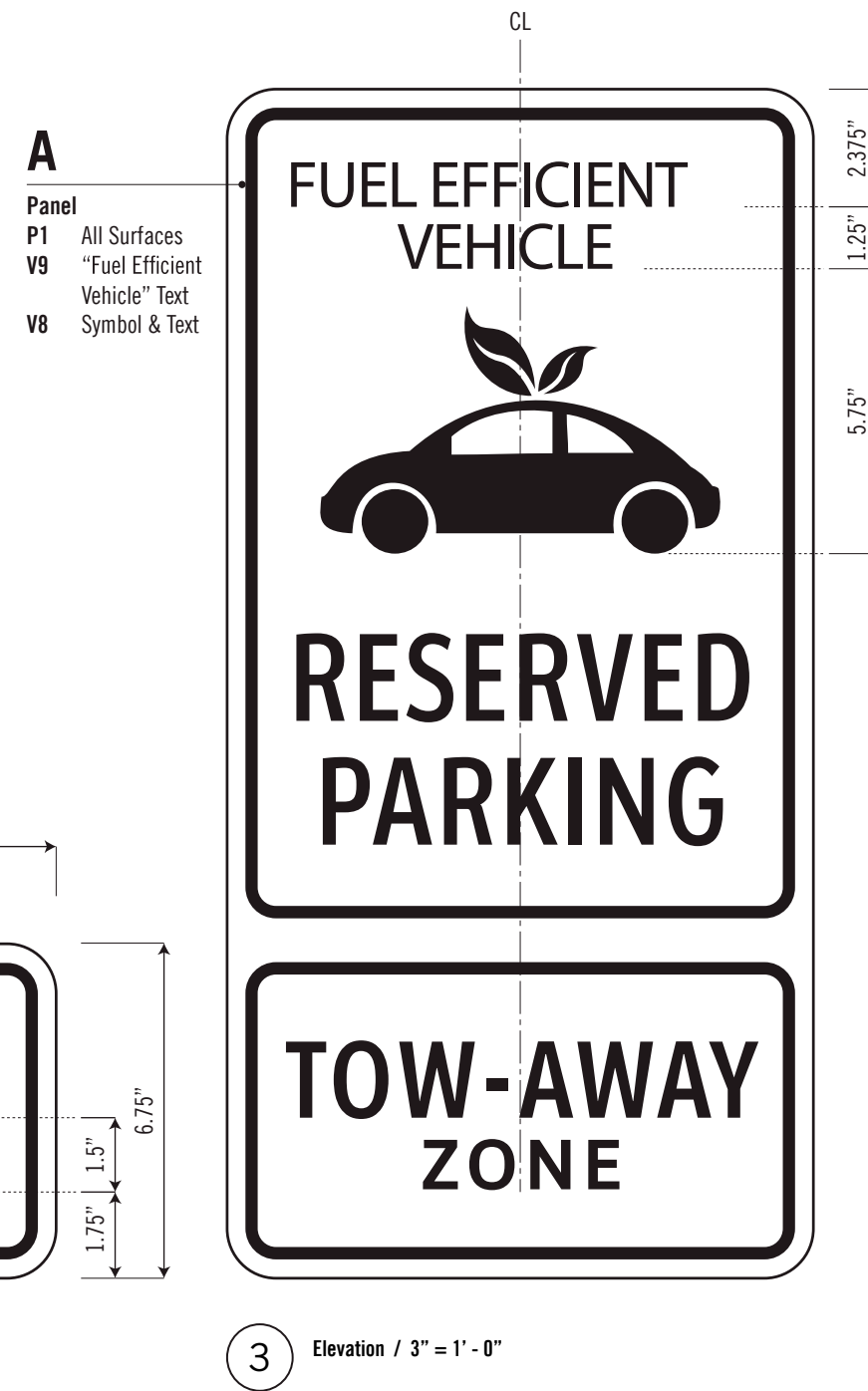
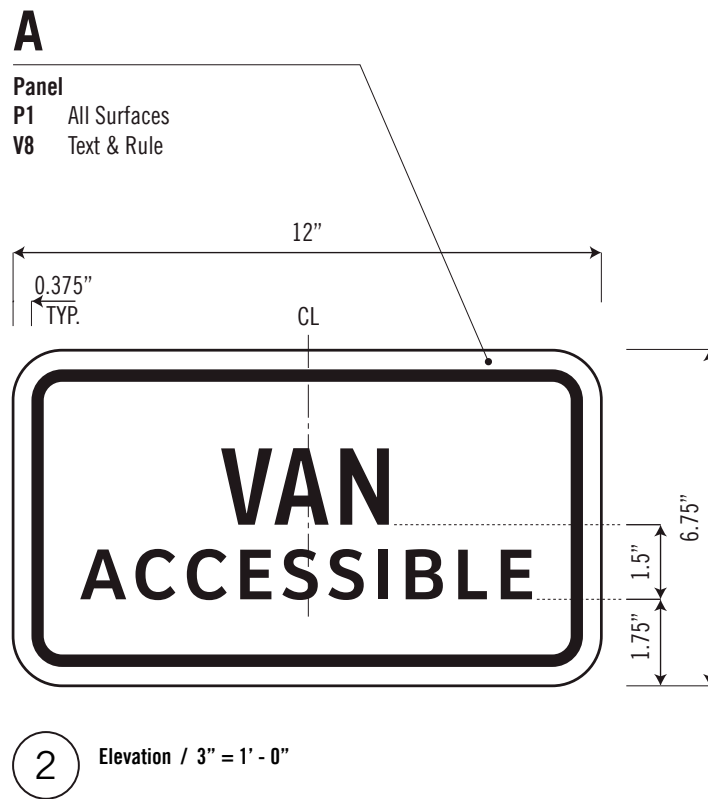

NOTE: Taken from DFW International Airport Headquarters document dated March 17, 2014

WARNING:

This record contains Sensitive Security Information that is controlled under 49 CFR parts 15 and 1520. No part of this record may be disclosed to persons with a "need to know," as defined in 49 CFR parts 15 and 1520, except with the written permission of the Administrator of the Transportation Security Administration or the Secretary of Transportation. Unauthorized release may result in civil penalty or other action. For U.S. government agencies, public disclosure is governed by 5 U.S.C. 552 and 49 CFR parts 15 and 1520.

Dimensions & shapes of all elements as shown on G3.E3a thru G3.E3b.



- A**
- Panel
 - P1 All Surfaces
 - V5 "Circle" Symbol
 - Text and Rule
 - V6 "P" Symbol

1 Elevation / 3" = 1' - 0"

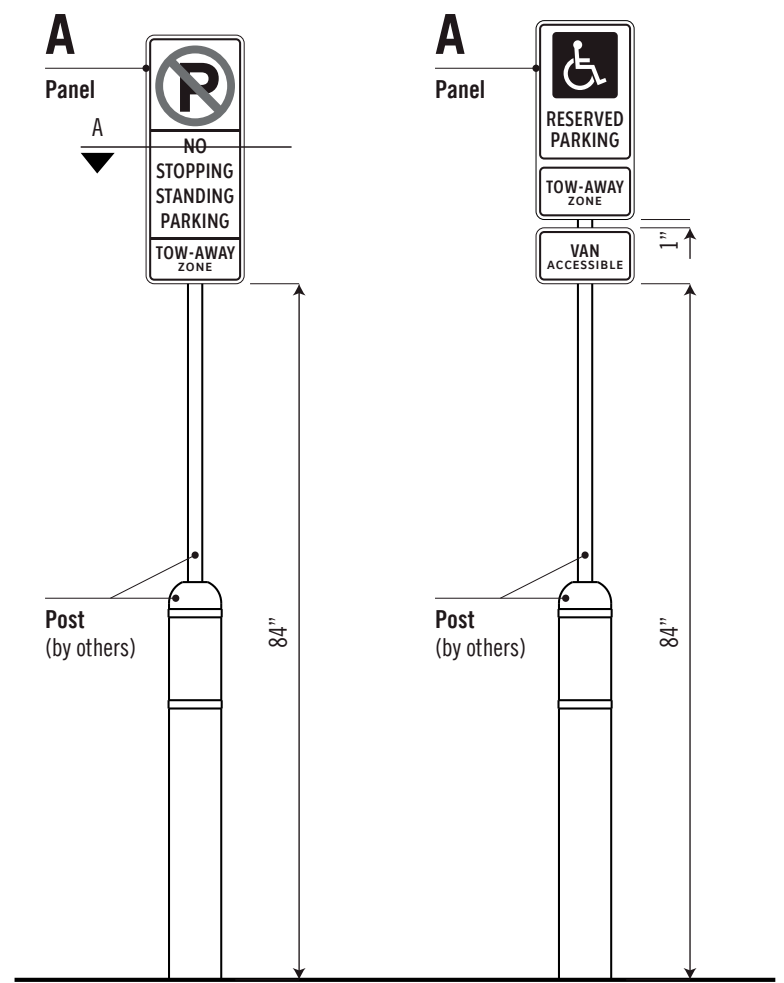
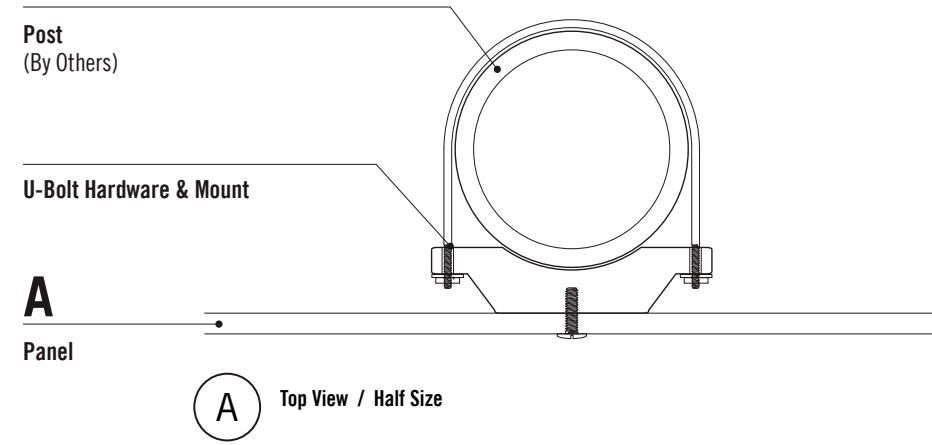

2 Elevation / 1/2" = 1' - 0"

NOTE: Taken from DFW International Airport Headquarters document dated March 17, 2014

ILLUMINATION	SIGN TYPE	SIGN FUNCTION	MOUNTING METHOD	GENERAL DESCRIPTION & USE
REFLECTIVE	5-D.55	DIRECTIONAL	POST MOUNT	VEHICULAR - Roadside/Visitor Parking

GENERAL NOTES

- All final design, engineering, and amount/sizing of structural sign support elements, material types/thicknesses, dimensions, and attachment methods shall be performed and approved by a licensed engineer to meet or exceed all applicable local and national codes.
- Final engineering, dimensions, materials, and fabrication are the responsibility of the Fabricator to ensure the highest quality fit and finish for all components of the completed product. All final detailing and specifications to be provided by the Fabricator within their final approved fabrication-ready shop drawings.
- Wherever dissimilar metals are in contact, always separate contact surfaces prior to assembly or installation with the necessary protective coatings/gaskets/washers to prevent galvanic corrosion.
- Final fabrication methods, quality and fit/finish to be reviewed and approved by DFW Planning Department and wayfinding/architecture Design Consultants thru prototype reviews prior to final production run/installation processes (see Performance Specifications for details).
- Colors shown are for reference only, and are subject to the limitations of the printing process and/or variance of electronic RGB screen displays. Refer to color system swatches and/or final finish samples for accurate reference.
- Messages shown here are general placeholders only. See graphic message schedules for specific messaging by location and sign type.

FABRICATION INTENT NOTES

- F1** SIGN FACE PANELS: 1/4" thick aluminum sign face panels; mechanically fasten sign panels to support tube structure with stainless steel tamper-proof screws, paint heads to match sign face; digitally printed full-bleed color graphics on 3M Reflective DG3 4090 White film applied to 1st surface of face panels; all exposed surfaces, returns, etc to be painted with MAP paint to match P1, satin finish
- F2** SUPPORT FRAME/POST ATTACHMENT: fabricated 1" square aluminum support tube frame structure; all exposed support frame tube ends to be capped with aluminum; all welds on frame/caps to be filled and ground smooth for uniform appearance; support frame mechanically attached to support post as required w/ mech. fasteners (fabricator to field verify); support frame to be painted all exposed surfaces with MAP paint to match P2, satin finish
- F3** PORTABLE PYRAMID BASE and POLE: By others. Mount per manufacturer recommendations.
- F4** SUPPORT POST: Fabricated square aluminum vertical support post tube; support post tube end to be capped with aluminum; all welds on frame/caps to be filled and ground smooth for uniform appearance; support post welded to foot plate and mechanically attached to concrete bollard; all support post/attachment plate/fasteners and exposed surfaces to be painted with MAP paint to match P2, satin finish
- F5** EXISTING CONCRETE BOLLARD: Existing concrete bollard

GRAPHICS / COLORS / DECORATION NOTES

L2 Typeface: font = ClearviewText Bold

VINYL (FILM) / DIGITAL PRINT/PAINT:

- P3** Orange: PMS 166 C
- V5** Black: 3M 7725-22
- V7** White: 3M 4090 DG3 White (Reflective)

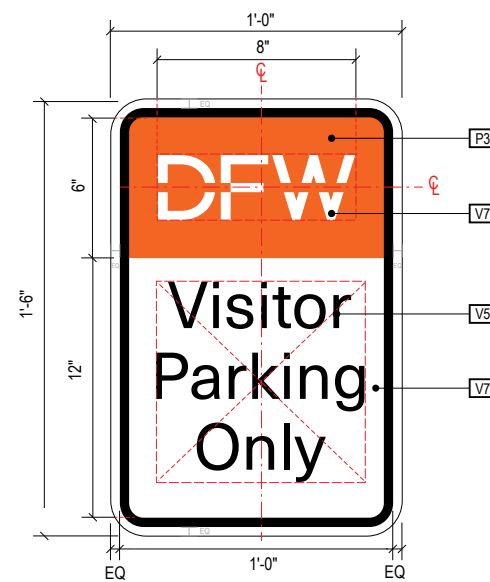

A FACE LAYOUT
Scale: NTS

1 PLAN VIEW
Scale: NTS

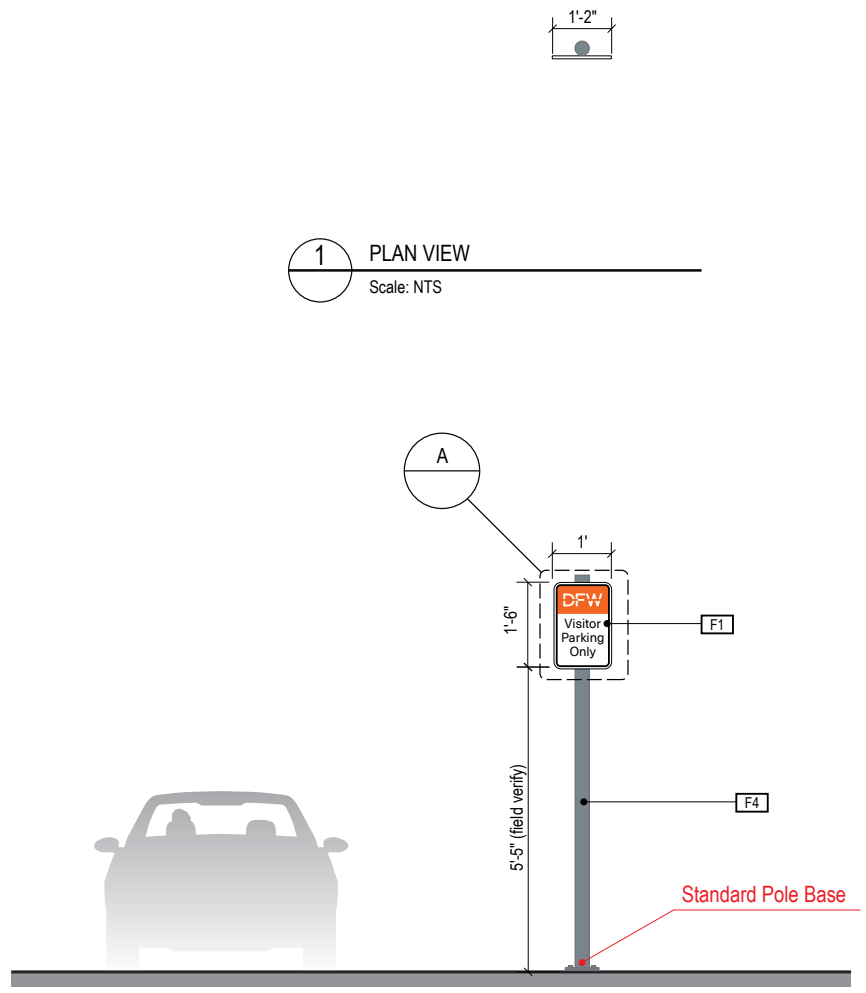

2 ELEVATION w/ Standard Base
Scale: NTS

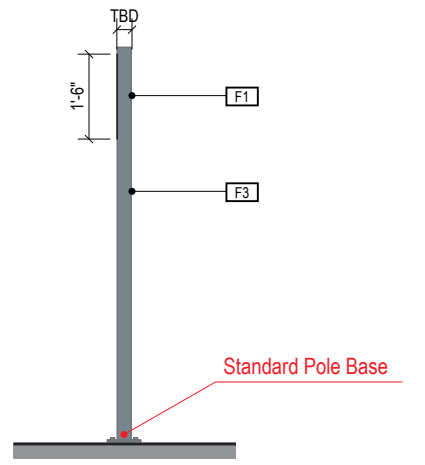

3 END VIEW
Scale: NTS

Dimensions & shapes of all elements as shown on G3.E4a.

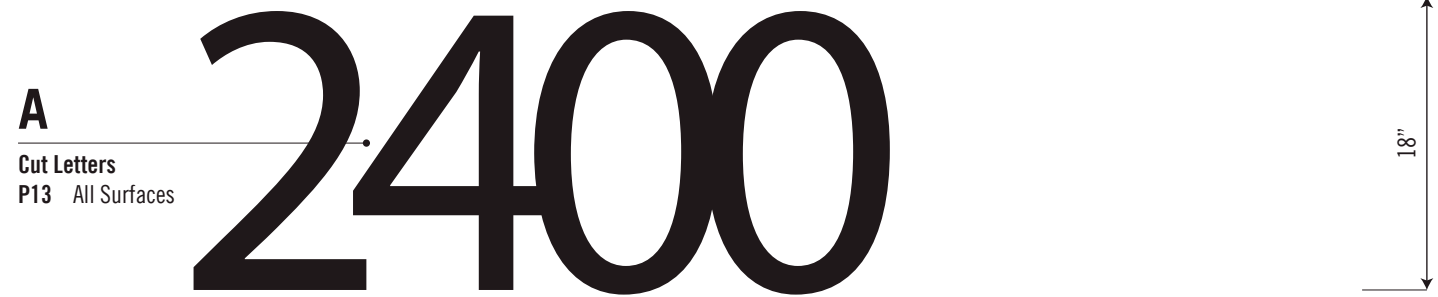

A
Cut Letters
P13 All Surfaces

2 Elevation / 1" = 1' - 0"

A Cut Letters:
Computer cut letters of 0.25" thick aluminum. Buff returns smooth and even to eliminate any tooling marks. Drill and tap reverse of each element for not less than 3 studs per element. Paint finish all surfaces as indicated.

Typography:
Clearview Hwy 5-W, Sized as indicated, Kerned -100%

Installation:
Concealed stud and silicone mount flush to wall surface. Seal all penetrations 360 degrees with a sealant approved by General Contractor. Designer will field locate exact installation location. Sign Contractor is responsible for field verifying all as-built conditions including building dimensions and indicate on shop drawings for review and approval.

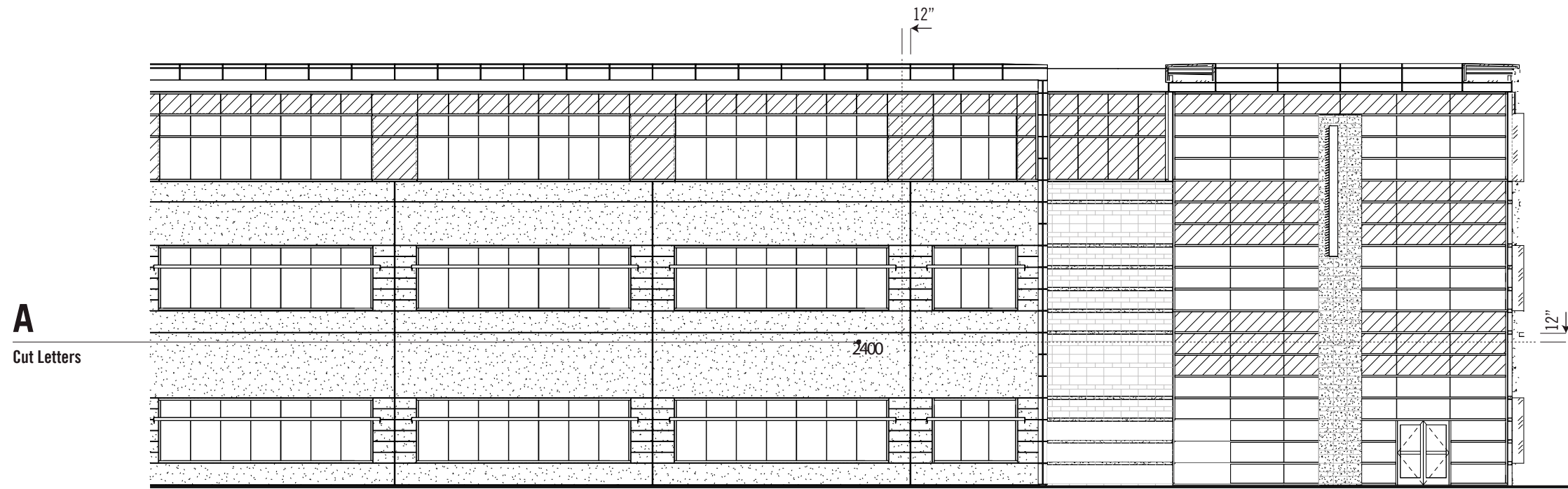

A
Cut Letters

1 Elevation / 1/16" = 1' - 0"

NOTE: Taken from DFW International Airport Headquarters document dated March 17, 2014

Dimensions & shapes of all elements as shown on G3.G1a.

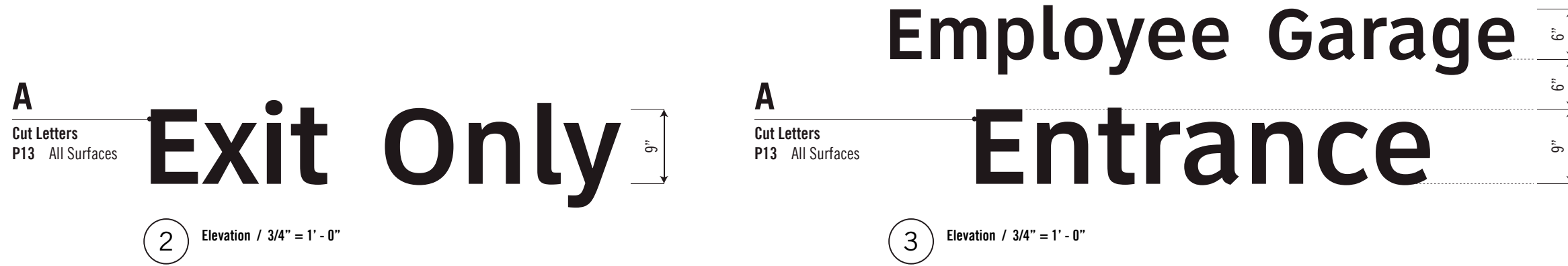

A Cut Letters:
Computer cut letters of 0.25" thick aluminum. Buff returns smooth and even to eliminate any tooling marks. Drill and tap reverse of each element for not less than 3 studs per element. Paint finish all surfaces as indicated.

Typography:
Clearview Hwy 5-W, Sized as indicated, Kerned -100%

Installation:
Concealed stud and silicone mount flush to wall surface. Seal all penetrations 360 degrees with a sealant approved by General Contractor. Designer will field locate exact installation location.

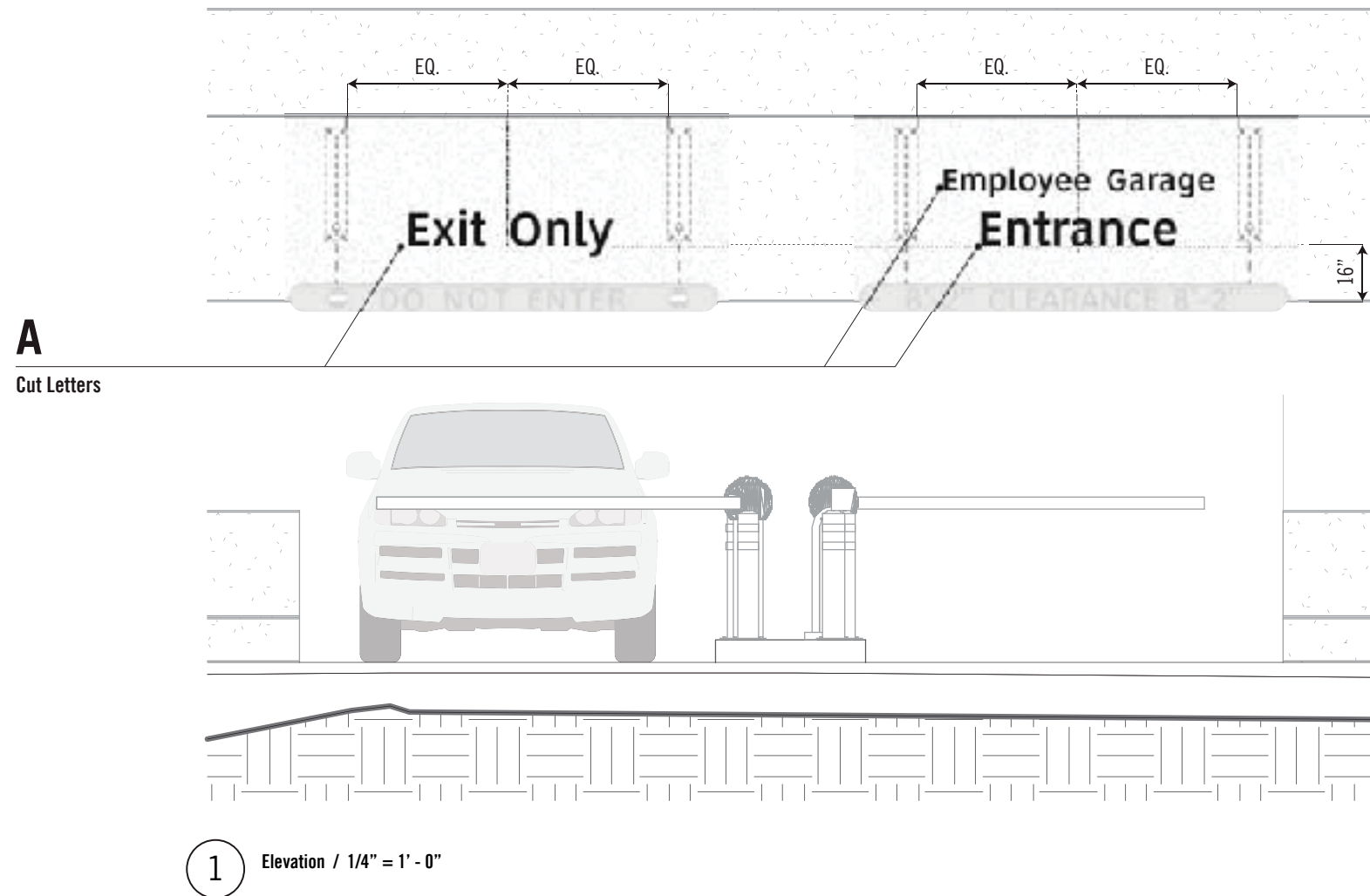

NOTE: Taken from DFW International Airport Headquarters document dated March 17, 2014

Dimensions & shapes of all elements as shown on G3.G2a.

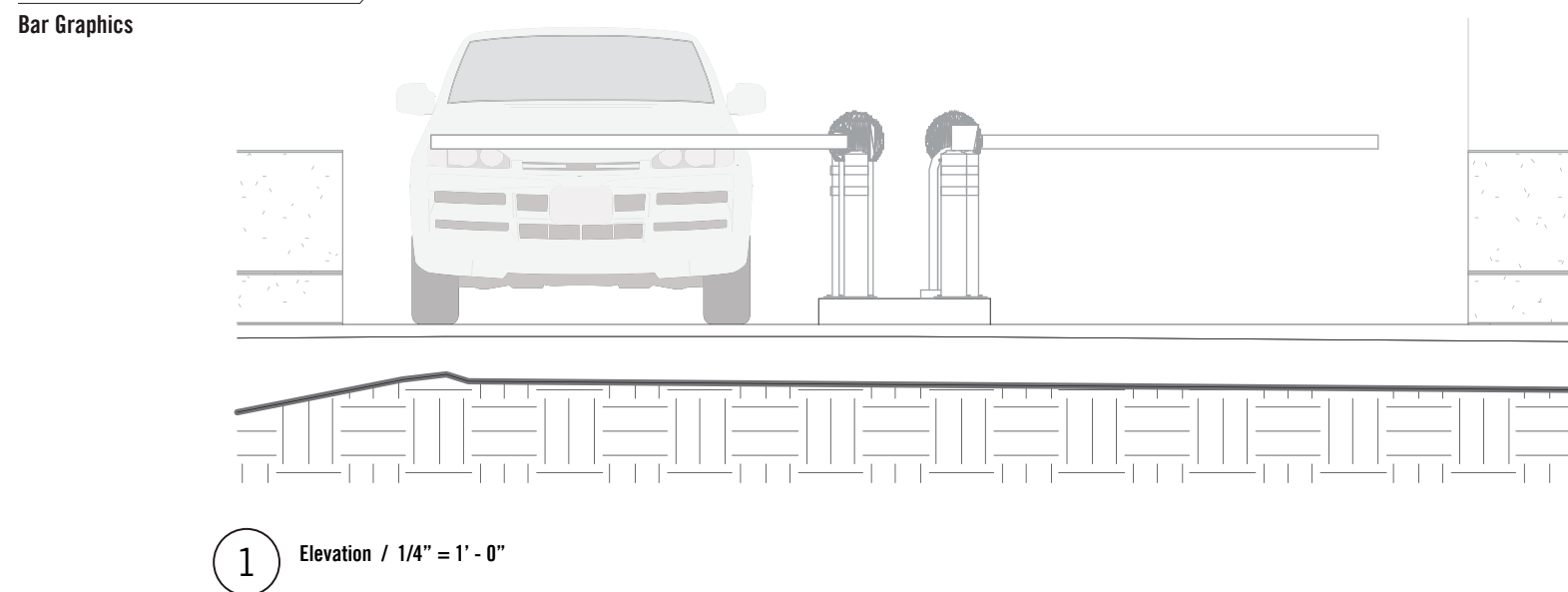
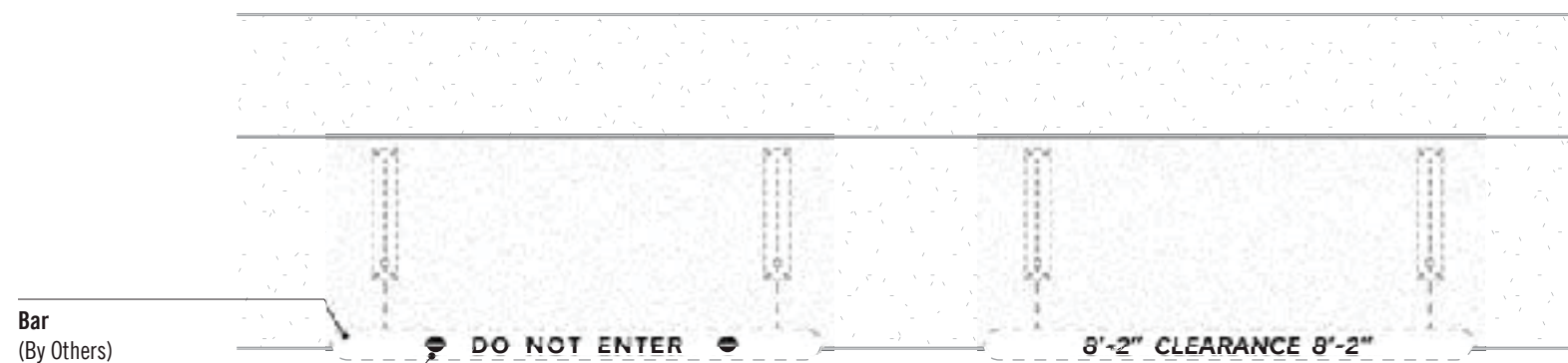
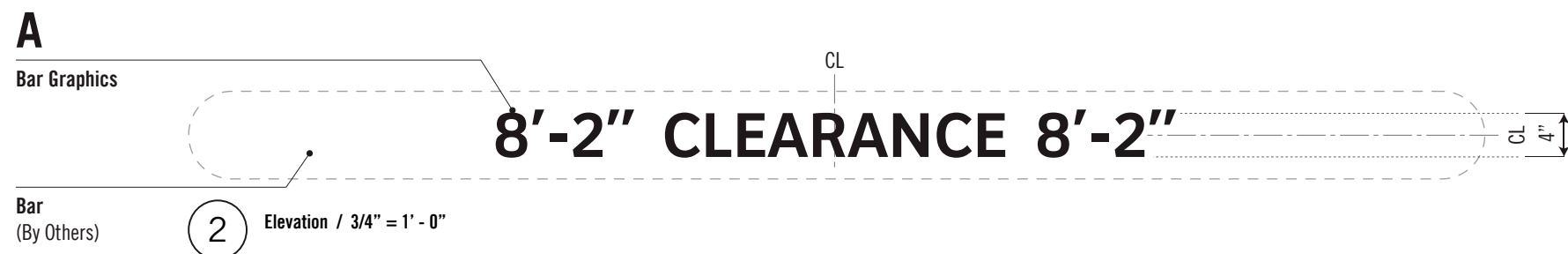
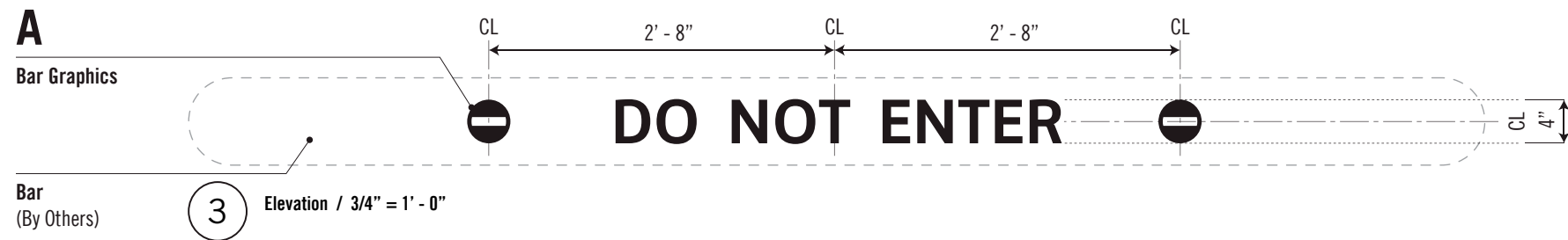

A Bar Graphics:

3M Computer-cut vinyl. First surface application. Sign Contractor to ensure contrast prior to fabrication. If not contrasting, notify designer. Sign Contractor responsible to verify as built conditions including color and size of PVC Headache Bar and indicate on shop drawings.

Typography:
Clearview Hwy 5-W, Sized as indicated, Kerned -120%

Symbols:
(DNE): 4" Height

Installation:

Clean surface & apply vinyl. Sign contractor to field verify clearance/Architect to provide actual clearance from field measurements. Sign Contractor is responsible for field verifying all as-built conditions that may impact installation & maintenance and indicate on shop drawings for review and approval.

NOTE: Taken from DFW International Airport Headquarters document dated March 17, 2014

Dimensions & shapes of all elements as shown on G3.G3a.

A Panel:
Aluminum Panel of 0.125" thickness. Cut to size and buff returns smooth and even to eliminate tooling marks. Paint finish all surfaces as indicated. Apply 3M Computer Cut Vinyl Graphics to first surface.

Typography:
Clearview Hwy 5-W, 4" Cap Height (Based on "E"), Kerned -25%.
For "Caution: Two Way Traffic" Clearview Hwy 2-W, 4" Cap Height, Kerned -25%.

Symbols:
Arrow: 6" Length; (STOP): 6" Height; (P):4" Height; (HC): 4" Height

Installation:
Concealed 3M VHB tape and silicone mount flush to concrete.
Designer to field verify exact mounting locations.

Sign contractor to verify all as-built conditions prior to fabrication including dimensions and indicate on shop drawings. Ensure that all elements are uniform, parallel and aligned.

B Panel:
Installation:
Mechanical attachment of panel to post with U-bolt hardware and mount sign contractor responsible to field verify all as build conditions to determine hardscape or softscape.

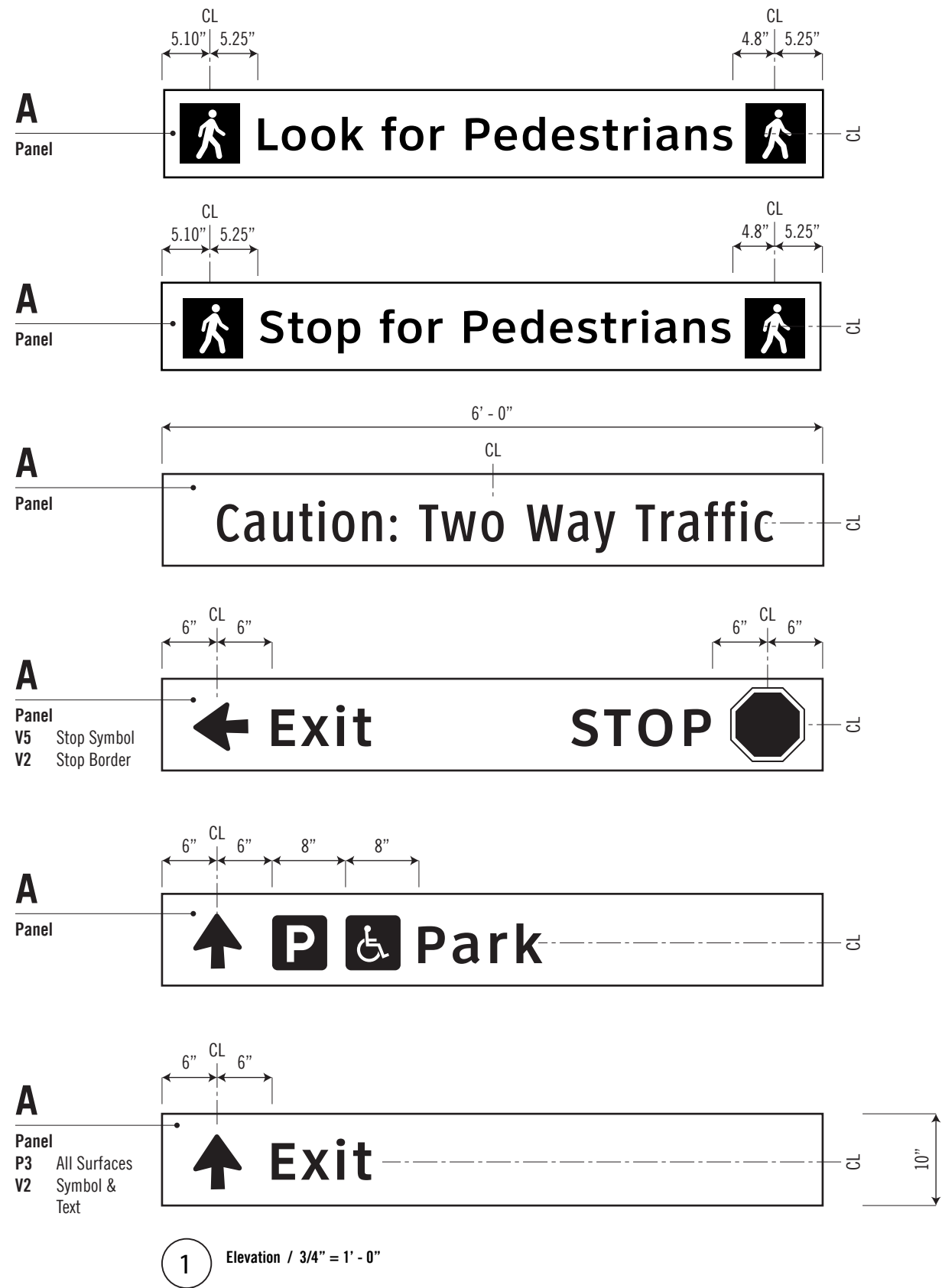

1 Elevation / 3/4" = 1' - 0"

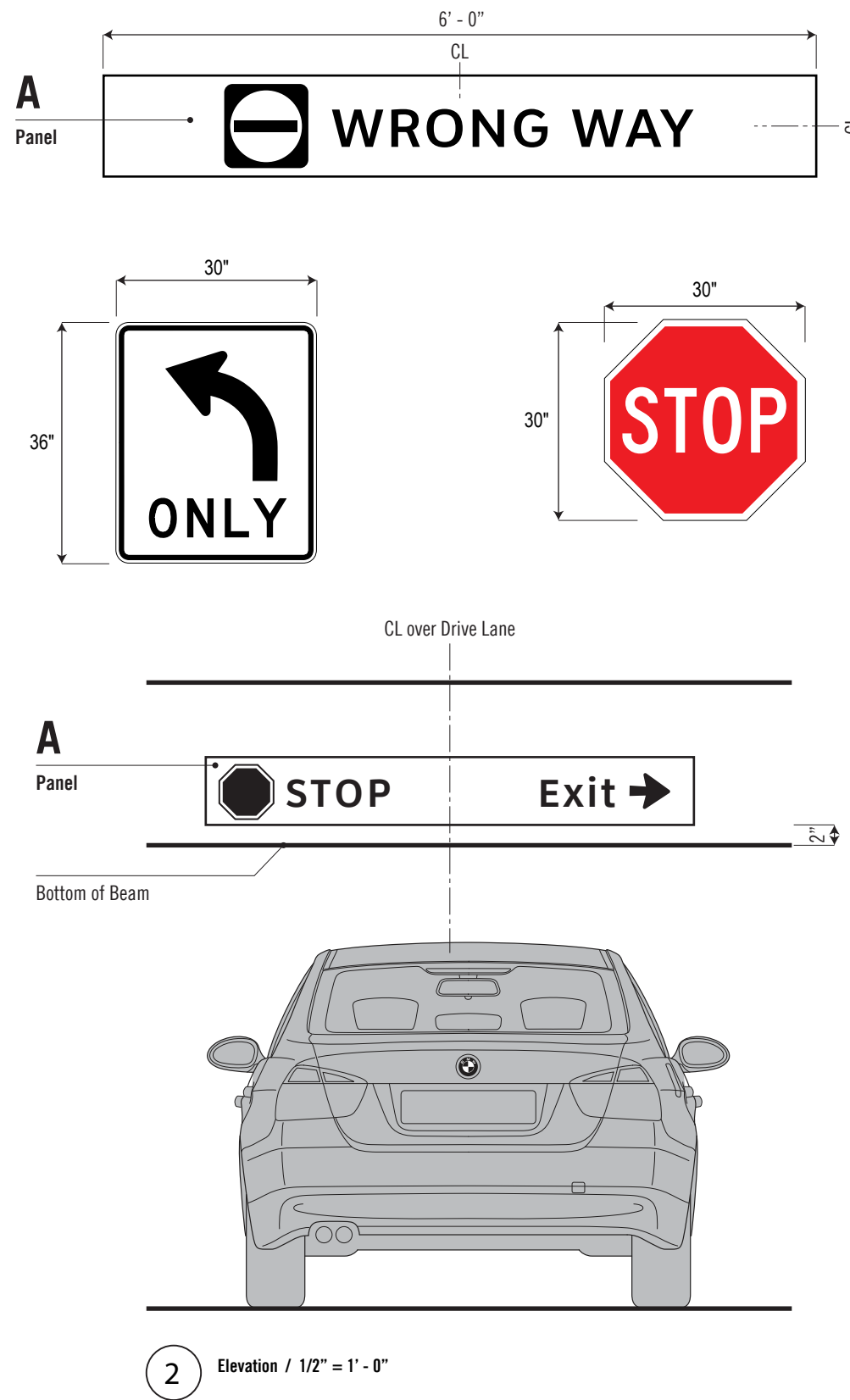

2 Elevation / 1/2" = 1' - 0"

NOTE: Page Updated dated September 30, 2021

Pavement Marking Notes

Colors shown are for reference only, and are subject to the limitations of the printing process and / or variance of electronic RGB screen displays. Refer to color system swatches and / or final finish samples for accurate reference.

Messages shown here are typical placeholders only.

All dimensions are approximate, where necessary, field verify for accuracy.

Pavement marking letters, numerals, symbols, and arrows shall be installed in accordance with the design details in the Pavement Markings chapter of the "Standard Highway Sign Designs for Texas" book.

Fabrication Notes (General Design Intent):

- COLORS:
- F1** White: PMS White C, Type DMS-8200 Traffic Paint
 - C1** Reference for print material: Texas Manual on Uniform Traffic Control Devices (TMUTCD)

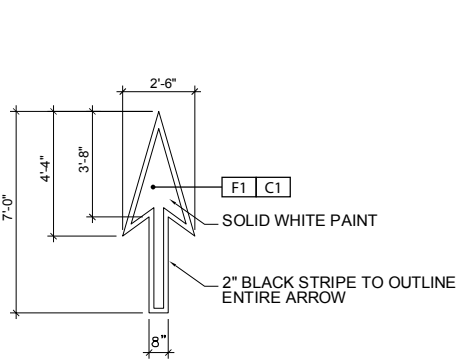

1 STRAIGHT ARROW PAVEMENT MARKING DETAIL
Not To Scale

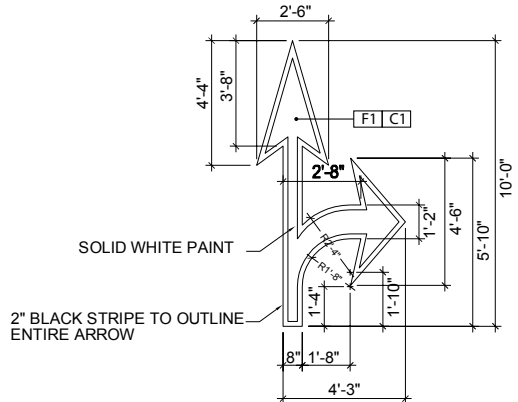

2 STRAIGHT RIGHT ARROW PAVEMENT MARKING DETAIL
Not To Scale

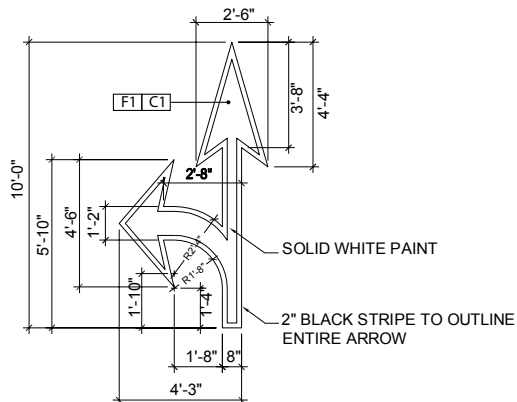

3 STRAIGHT LEFT ARROW PAVEMENT MARKING DETAIL
Not To Scale

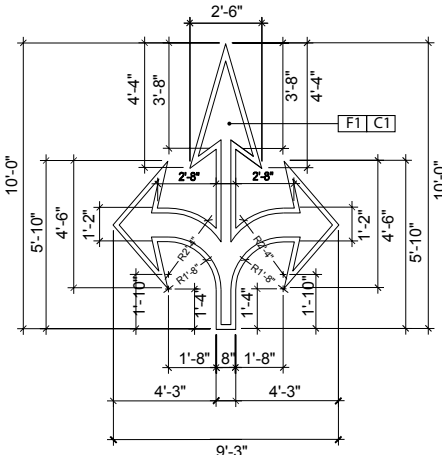

4 STRAIGHT LEFT RIGHT ARROW PAVEMENT MARKING DETAIL
Not To Scale

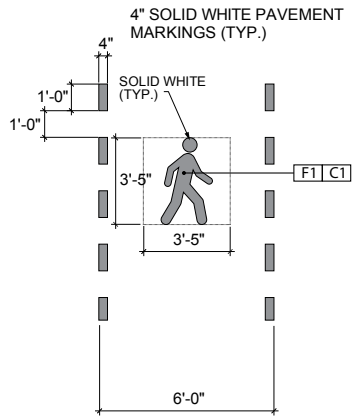

5 PEDESTRIAN PAVEMENT MARKING DETAIL
Not To Scale

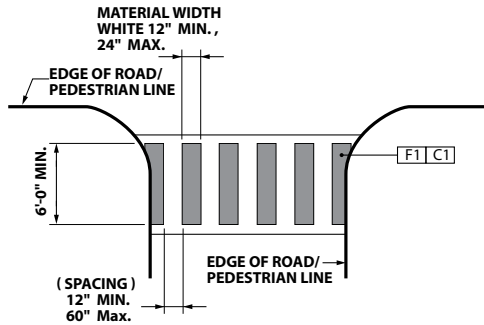

6 STANDARD CROSSWALK PAVEMENT MARKING DETAIL
Not To Scale

NOTE: CONTRACTOR SHALL LEAVE TEMPLATE WITH OWNER

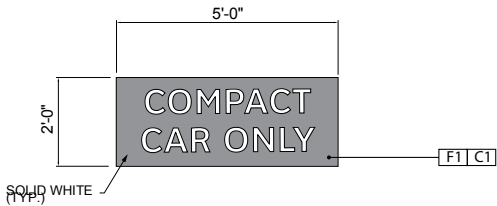

NOTE: CONTRACTOR SHALL LEAVE TEMPLATE WITH OWNER

7 COMPACT CAR PAVEMENT MARKING DETAIL
Not To Scale

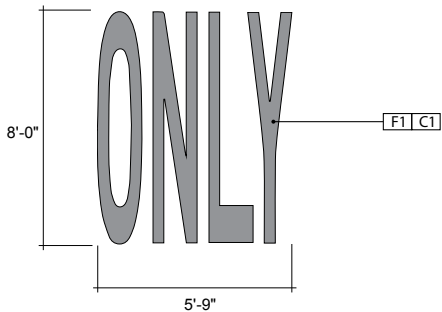

NOTE: CONTRACTOR SHALL LEAVE TEMPLATE WITH OWNER

8 ONLY PAVEMENT MARKING DETAIL
Not To Scale

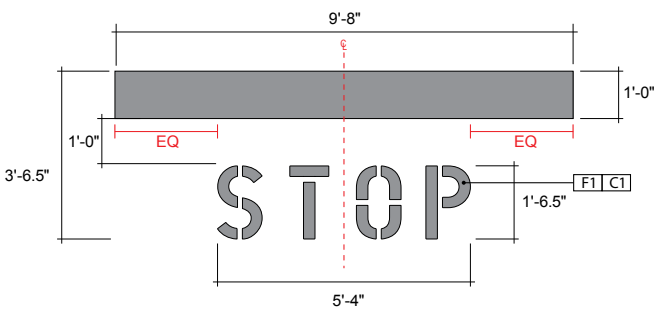

NOTE: CONTRACTOR SHALL LEAVE TEMPLATE WITH OWNER

9 STOP PAVEMENT MARKING DETAIL
Not To Scale

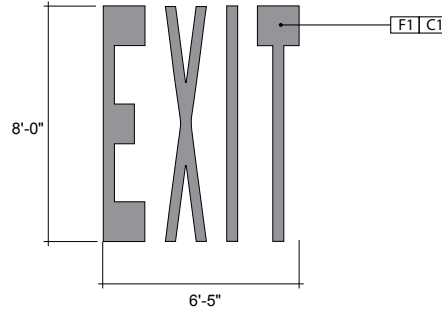

NOTE: CONTRACTOR SHALL LEAVE TEMPLATE WITH OWNER

10 EXIT PAVEMENT MARKING DETAIL
Not To Scale

NOTE: Page Updated dated September 30, 2021

Dimensions & shapes of all elements as shown on G3.G4a thru G3.G4b.

A Panel:
Aluminum Panel of 0.125" thickness. Cut to size and buff returns smooth and even to eliminate tooling marks. Paint finish all surfaces as indicated and screen print graphics to first surface.

Typography:
Clearview Hwy 4-W, 2.5" Cap Height (Based on "E"), Kerned -50%.

Symbols:
Arrow: 3" Length; Logo: 6"

Installation:
Concealed 3M VHB tape and silicone mount flush to concrete. Designer to field verify exact mounting locations.



A
Panel
P9 Level 3
(All Surfaces)
P13 Text

Footer
P3 Background
P1 Text

1 Elevation / 3" = 1'-0"

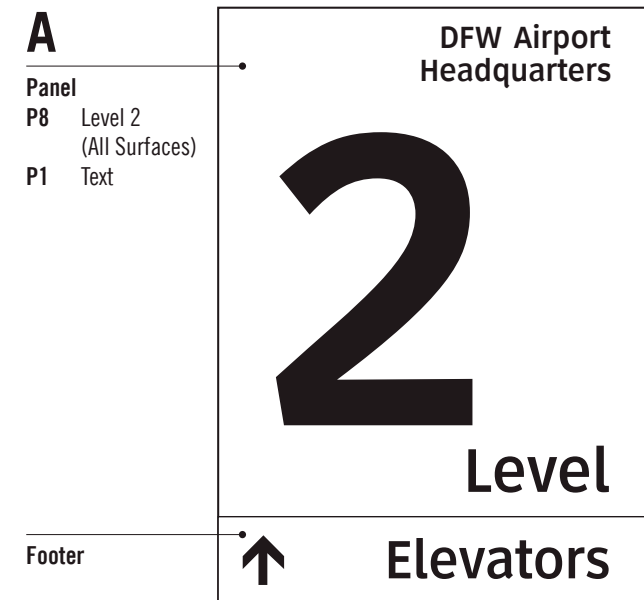

A
Panel
P8 Level 2
(All Surfaces)
P1 Text

Footer

2 Elevation / 1 1/2" = 1'-0"

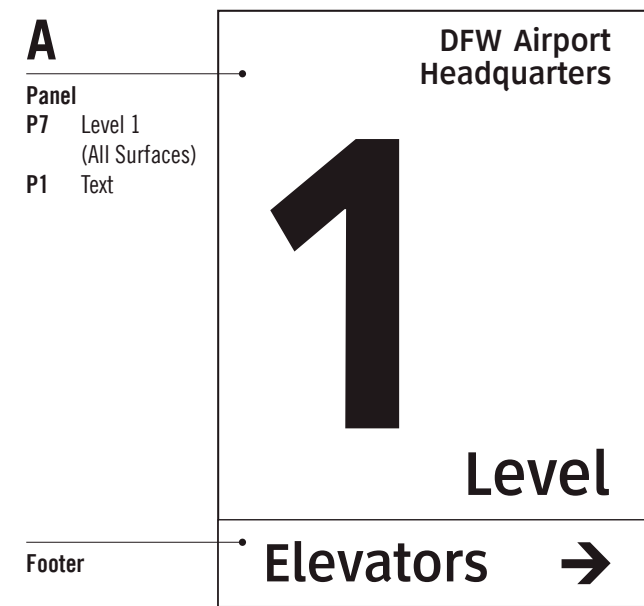

A
Panel
P7 Level 1
(All Surfaces)
P1 Text

Footer

NOTE: Taken from DFW International Airport Headquarters document dated March 17, 2014

Dimensions & shapes of all elements as shown on G3.G4a thru G3.G4b.

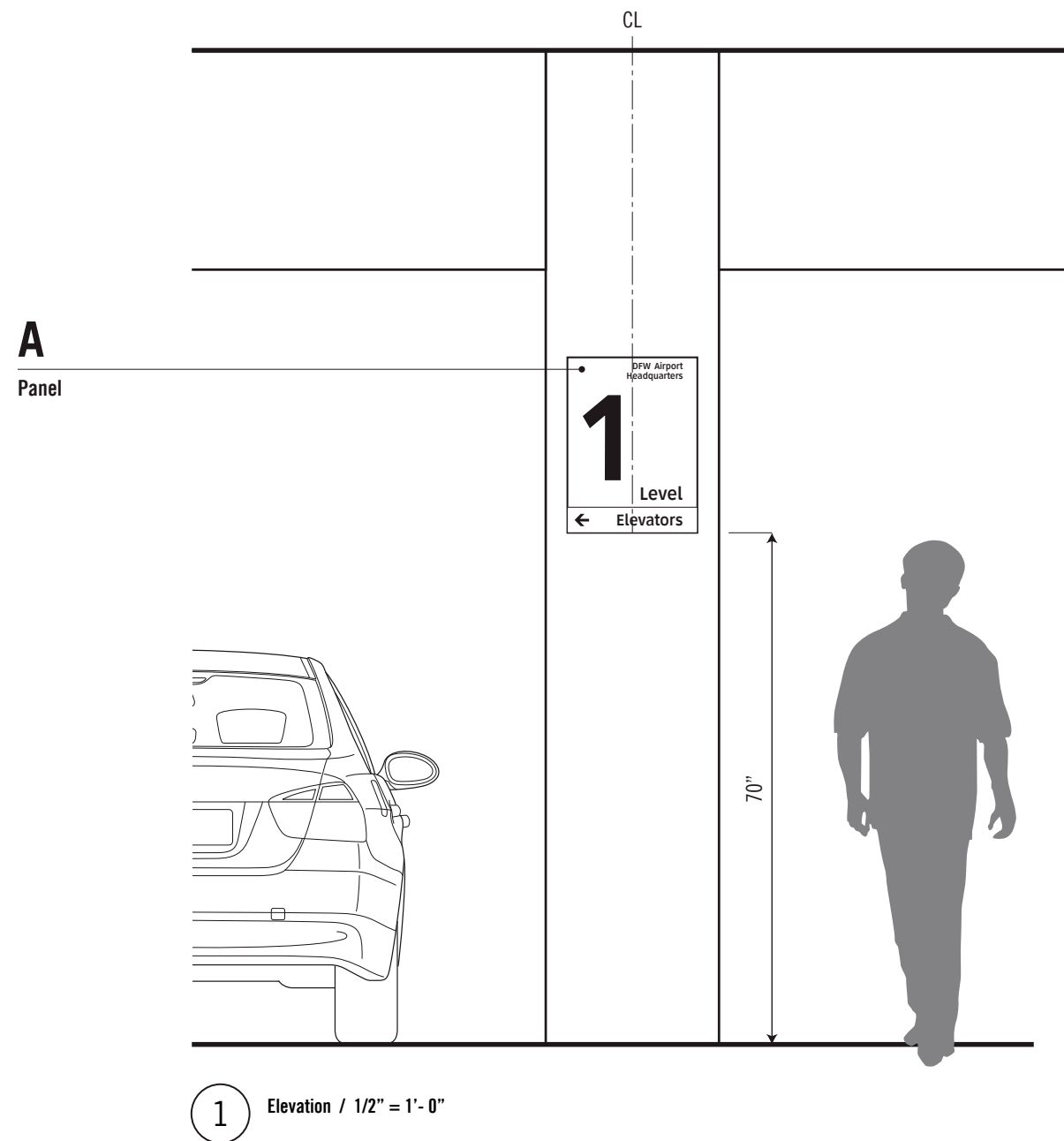

NOTE: Taken from DFW International Airport Headquarters document dated March 17, 2014

WARNING:

This record contains Sensitive Security Information that is controlled under 49 CFR parts 15 and 1520. No part of this record may be disclosed to persons with a "need to know," as defined in 49 CFR parts 15 and 1520, except with the written permission of the Administrator of the Transportation Security Administration or the Secretary of Transportation. Unauthorized release may result in civil penalty or other action. For U.S. government agencies, public disclosure is governed by 5 U.S.C. 552 and 49 CFR parts 15 and 1520.

Dimensions & shapes of all elements as shown on G3.G5a thru G3.G5b

A Panel:

Aluminum Panel of 0.125" thickness. Cut to size and buff returns smooth and even to eliminate tooling marks. Paint finish all surfaces as indicated. Screen print text to first surface.

Typography:

Clearview Hwy 5-W, 16" Cap Height (Based on "1"). For "Level" Clearview Hwy 4-W, 2.25" Cap Height (Based on "E"), Kerned -100%. For "DFW Airport Headquarters" Clearview Hwy 4-W, 1.25" Cap Height (Based on "E"), Kerned -100%.

Installation:

Concealed 3M VHB tape and silicone, mount flush to wall.

B Vinyl:

Computer-cut vinyl graphics applied to first surface of glass.

Typography:

Clearview Hwy 5-W, 16" Cap Height (Based on "1"). For "Level" Clearview Hwy 4-W, 2.25" Cap Height (Based on "E"), Kerned -100%. For "DFW Airport Headquarters" Clearview Hwy 4-W, 1.25" Cap Height (Based on "E"), Kerned -100%.

Installation:

Clean glass prior to installation. Install vinyl background to surface of glass, install vinyl text to background.

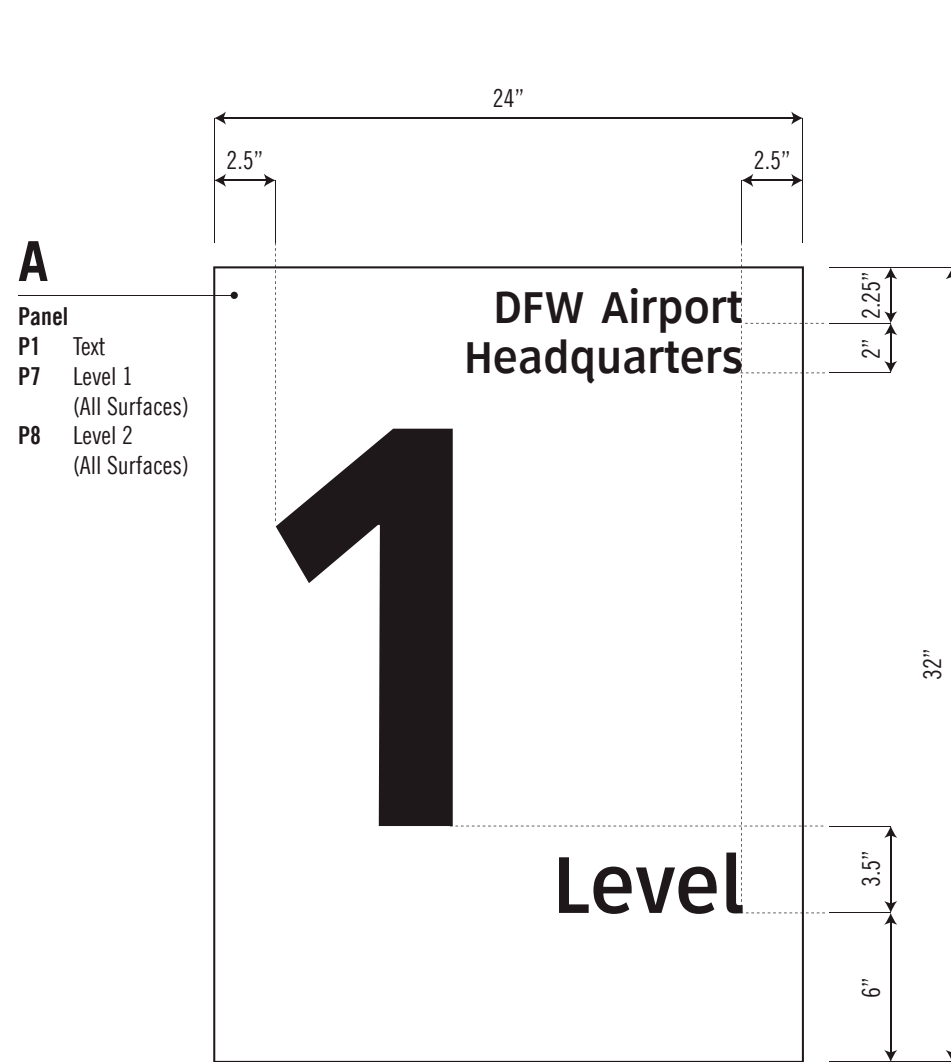

A

- Panel
- P1 Text
- P7 Level 1 (All Surfaces)
- P8 Level 2 (All Surfaces)

1 Elevation / 1 1/2" = 1'-0" Level 1 and 2

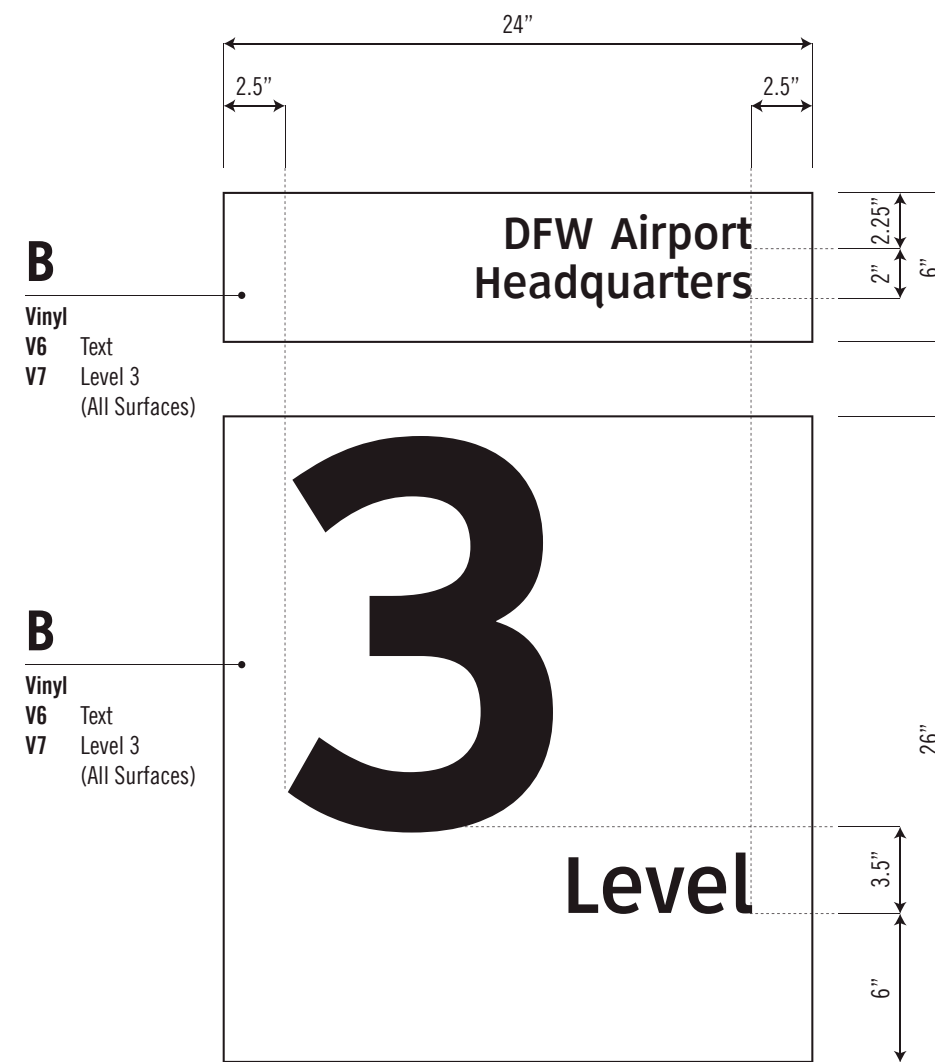

B

- Vinyl
- V6 Text
- V7 Level 3 (All Surfaces)

B

- Vinyl
- V6 Text
- V7 Level 3 (All Surfaces)

2 Elevation / 1 1/2" = 1'-0" Level 3

NOTE: Taken from DFW International Airport Headquarters document dated March 17, 2014

WARNING:

This record contains Sensitive Security Information that is controlled under 49 CFR parts 15 and 1520. No part of this record may be disclosed to persons with a "need to know," as defined in 49 CFR parts 15 and 1520, except with the written permission of the Administrator of the Transportation Security Administration or the Secretary of Transportation. Unauthorized release may result in civil penalty or other action. For U.S. government agencies, public disclosure is governed by 5 U.S.C. 552 and 49 CFR parts 15 and 1520.

Dimensions & shapes of all elements as shown on G3.G5a thru G3.G5b

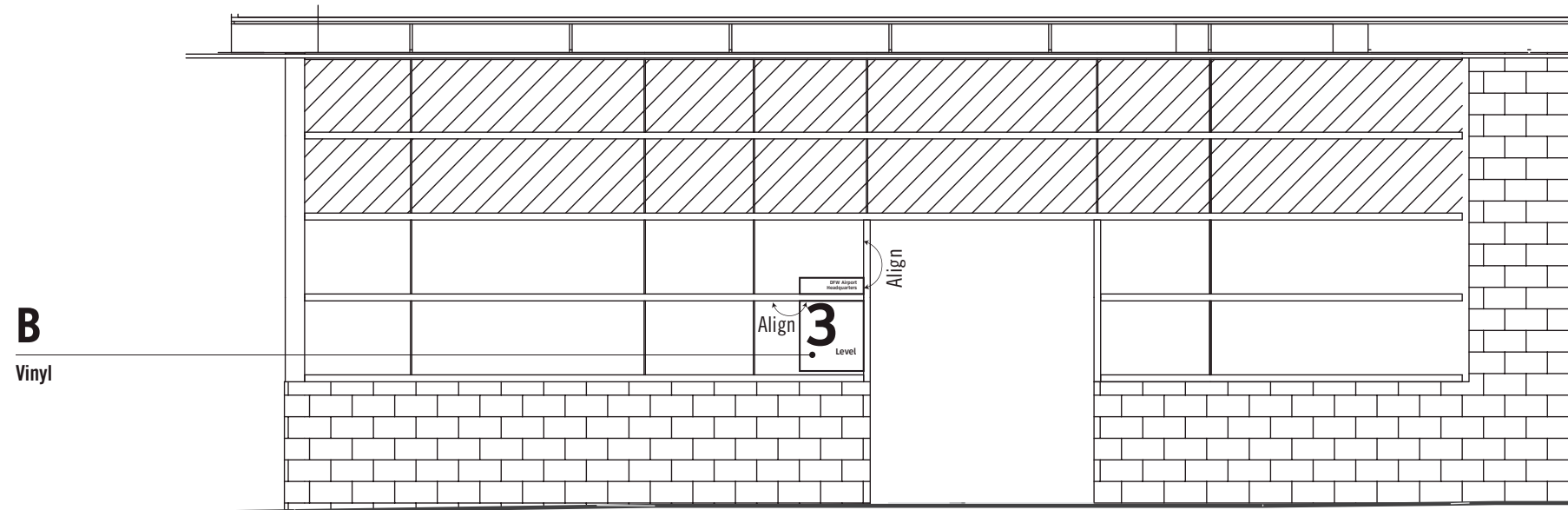

2 Elevation / 3/16" = 1'-0"
3rd Floor

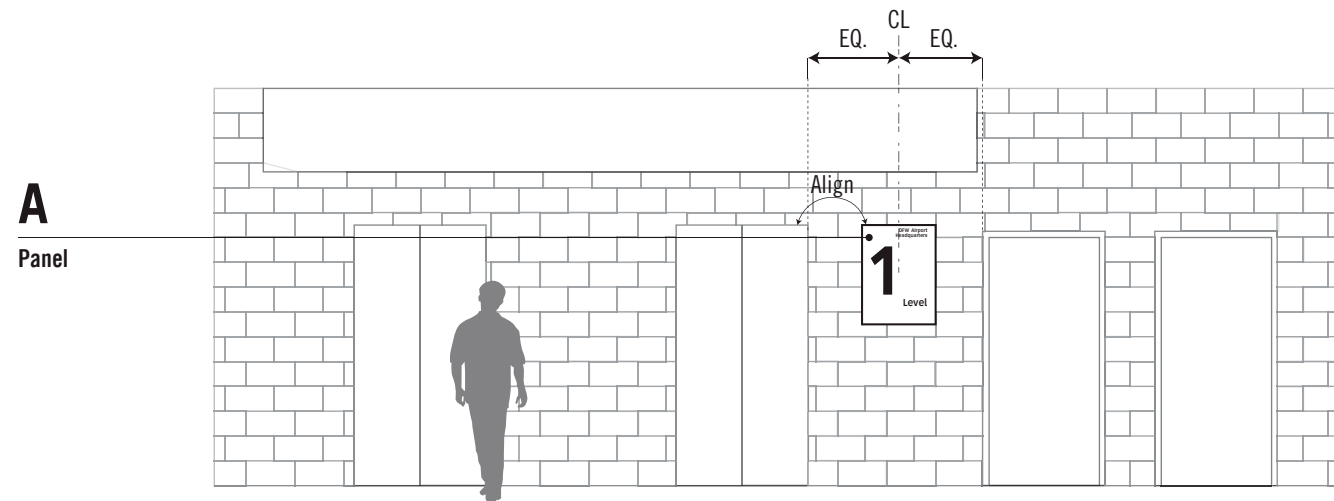

1 Elevation / 3/16" = 1'-0"
1st Floor shown, Typical for 1st and 2nd floor

NOTE: Taken from DFW International Airport Headquarters document dated March 17, 2014

Dimensions & shapes of all elements as shown on G3.G6a thru G3.G6b.

A Panel:

Aluminum Panel of 0.090" thickness. Cut to shape and buff returns smooth and even to eliminate tooling marks. Paint all surfaces as indicated. Apply 3M Computer Cut Vinyl Graphics to first surface.

Typography

For "Reserved Parking", Clearview Hwy 2-W, 1.75" Cap Height (Based on "E"), Interline Spacing of 2.5". For "Tow-Away" and "Van", Clearview Hwy 2-B, 1.5" Cap Height (Based on "E"). For "Zone" and "Accessible", Clearview Hwy 5-W, 1" Cap Height (Based on "E").

Symbols:

(HC): 8" height; Fuel Efficient Car: 5" Height; Rule: 0.25" thickness

Installation:

Mechanical Attachment of panel to existing post with U-bolt Hardware and Mount Sign contractor responsible to field verify all as build conditions to determine hardscape or softscape.

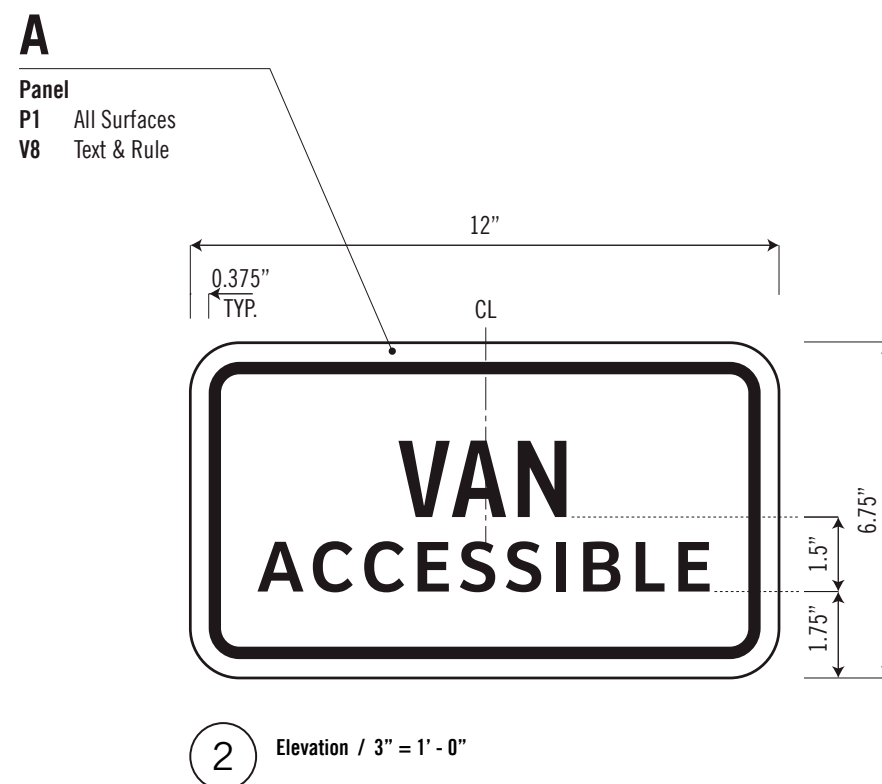

NOTE: Taken from DFW International Airport Headquarters document dated March 17, 2014

WARNING:

This record contains Sensitive Security Information that is controlled under 49 CFR parts 15 and 1520. No part of this record may be disclosed to persons with a "need to know," as defined in 49 CFR parts 15 and 1520, except with the written permission of the Administrator of the Transportation Security Administration or the Secretary of Transportation. Unauthorized release may result in civil penalty or other action. For U.S. government agencies, public disclosure is governed by 5 U.S.C. 552 and 49 CFR parts 15 and 1520.

Dimensions & shapes of all elements as shown on G3.G6a thru G3.G6b.

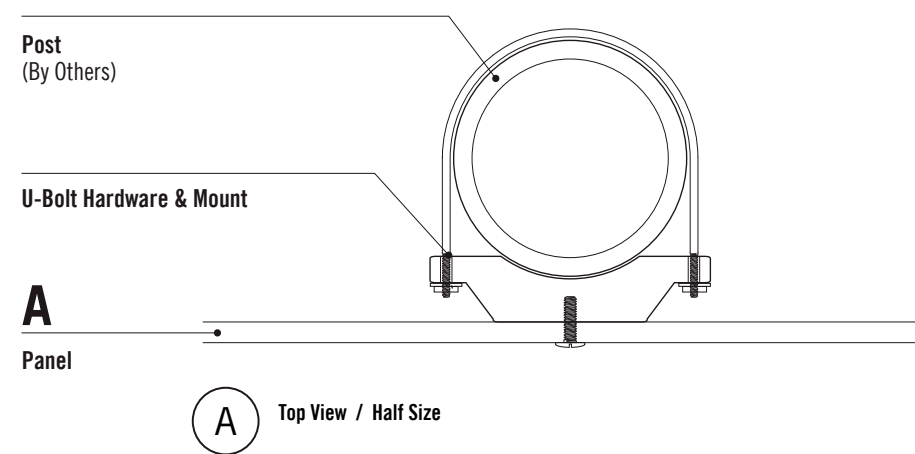
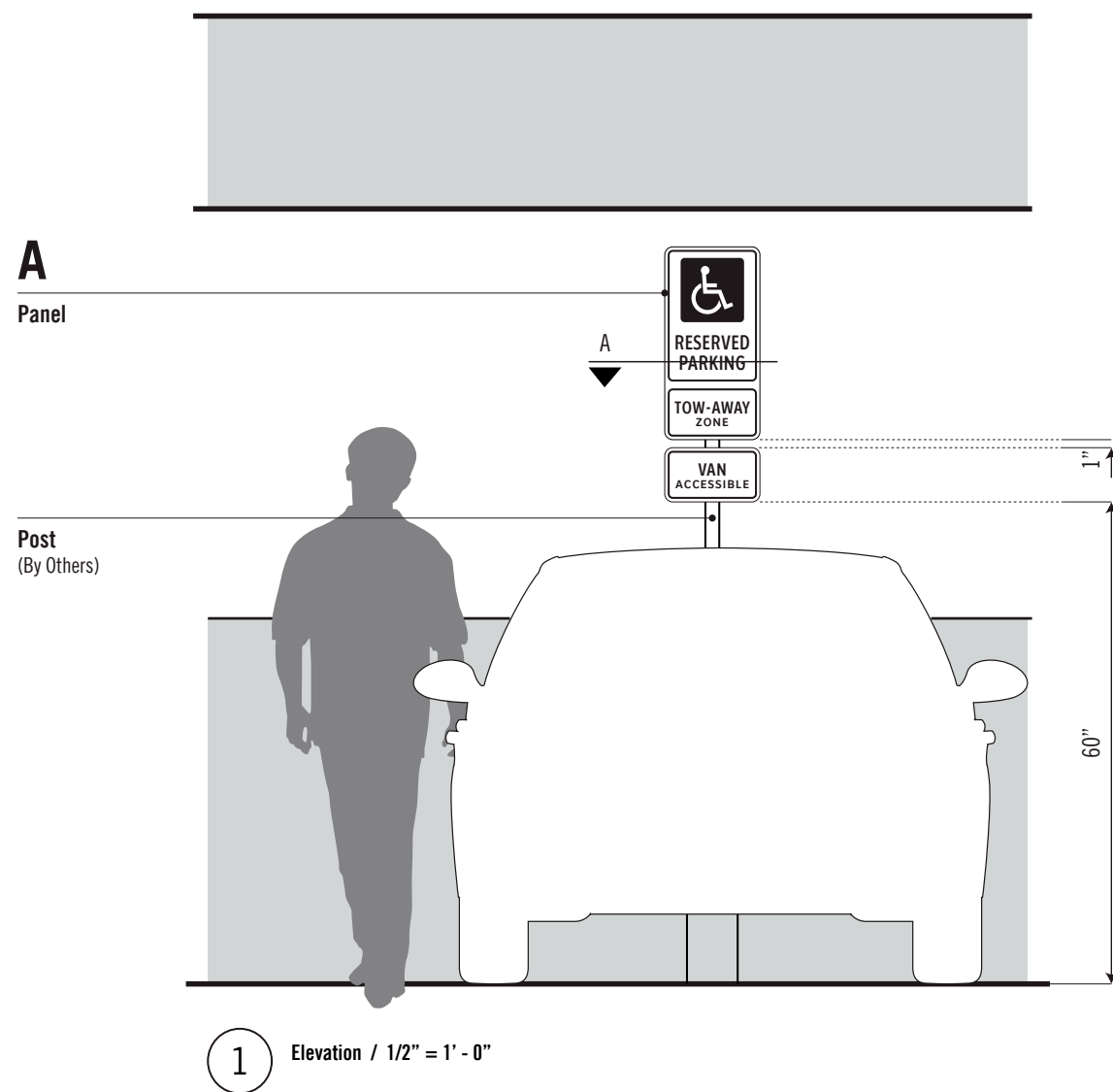

NOTE: Taken from DFW International Airport Headquarters document dated March 17, 2014

Dimensions & shapes of all elements as shown on G3.G7a thru G3.G7b.

A Panel:

Two (2) panels per location. Aluminum Panel of 0.090" thickness. Cut to size and buff returns smooth and even to eliminate tooling marks. Paint all surfaces as indicated. Apply 3M Computer Cut Vinyl Graphics to first surface. Mount to post - post to be provided by others. Concealed adhesive mount hinge to top of panels as shown. Configured to allow top panel to swing 180 degrees.

Typography

For "Reserved Parking", Clearview Hwy 2-W, 1.75" Cap Height (Based on "E"), Interline Spacing of 2.5". For "Tow-Away" and "Van", Clearview Hwy 2-B, 1.5" Cap Height (Based on "E"). For "Zone" and "Accessible", Clearview Hwy 5-W, 1" Cap Height (Based on "E").

B Hinge:

Larsen and Shaw, Part No. 1416D42SS
 Material Type Stainless Steel
 Material Gauge 0.060"
 Pin Diameter 0.125"
 Knuckle Length 0.50"
 Width 1.25"
 Length 10"
 Holes No
 Product Stainless Steel Custom Hinge
 www.larsenhinge.com

C Clip Assembly:

Custom stainless steel assembly of threaded bolt and nut with washer, stand-off and clip. Configured to hold top panel securely.

Installation:

Mechanical Attachment of panel to existing post with U-bolt Hardware and Mount Sign contractor responsible to field verify all as build conditions to determine hardscape or softscape.

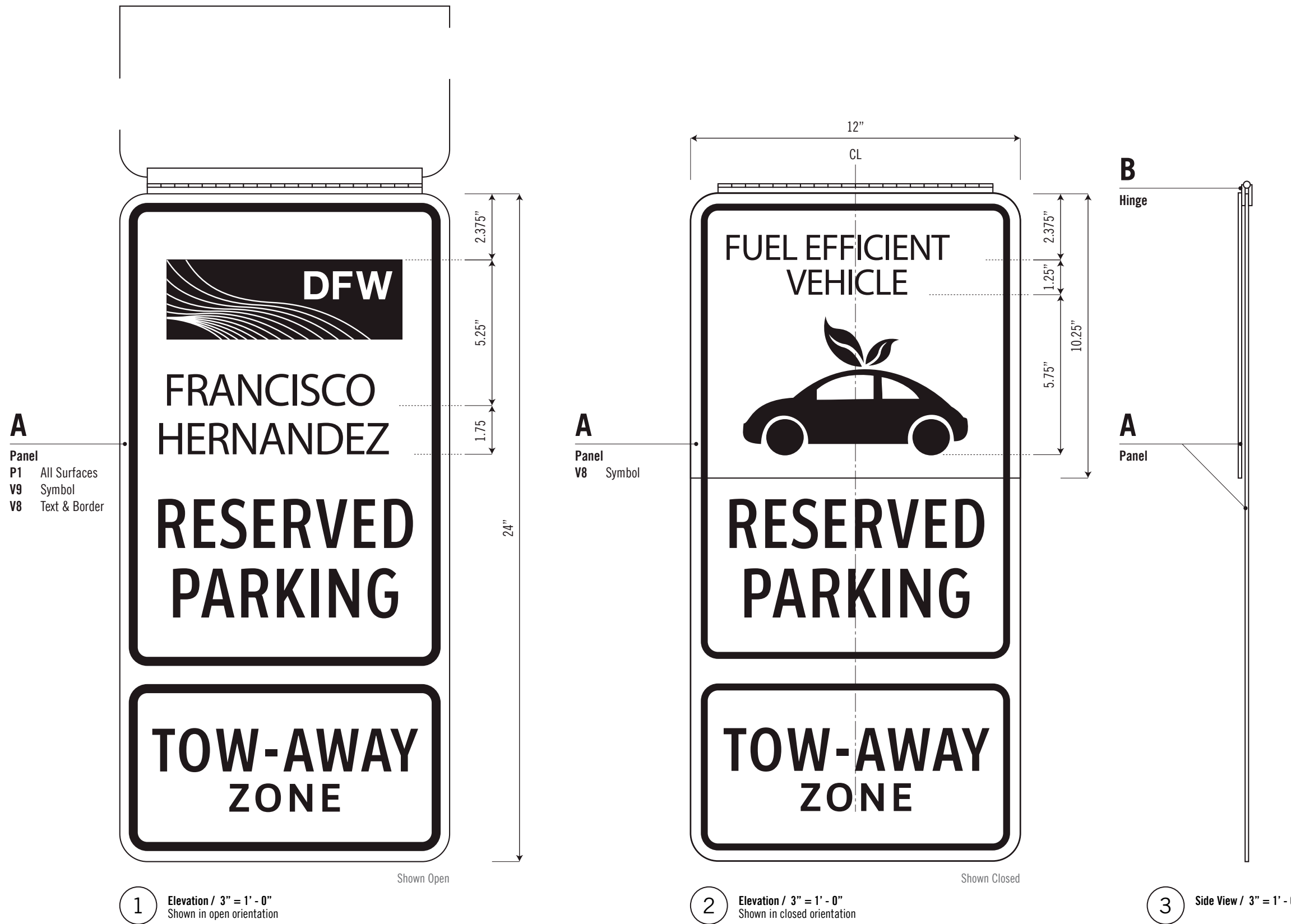

NOTE: Taken from DFW International Airport Headquarters document dated March 17, 2014

WARNING:

This record contains Sensitive Security Information that is controlled under 49 CFR parts 15 and 1520. No part of this record may be disclosed to persons with a "need to know," as defined in 49 CFR parts 15 and 1520, except with the written permission of the Administrator of the Transportation Security Administration or the Secretary of Transportation. Unauthorized release may result in civil penalty or other action. For U.S. government agencies, public disclosure is governed by 5 U.S.C. 552 and 49 CFR parts 15 and 1520.

Dimensions & shapes of all elements as shown on G3.G7a thru G3.G7b.

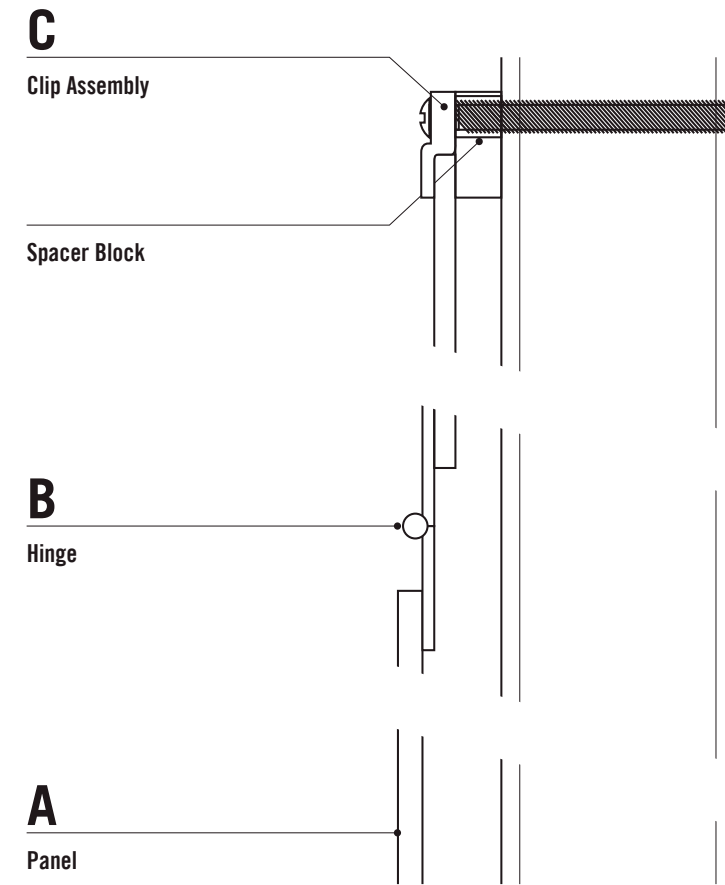
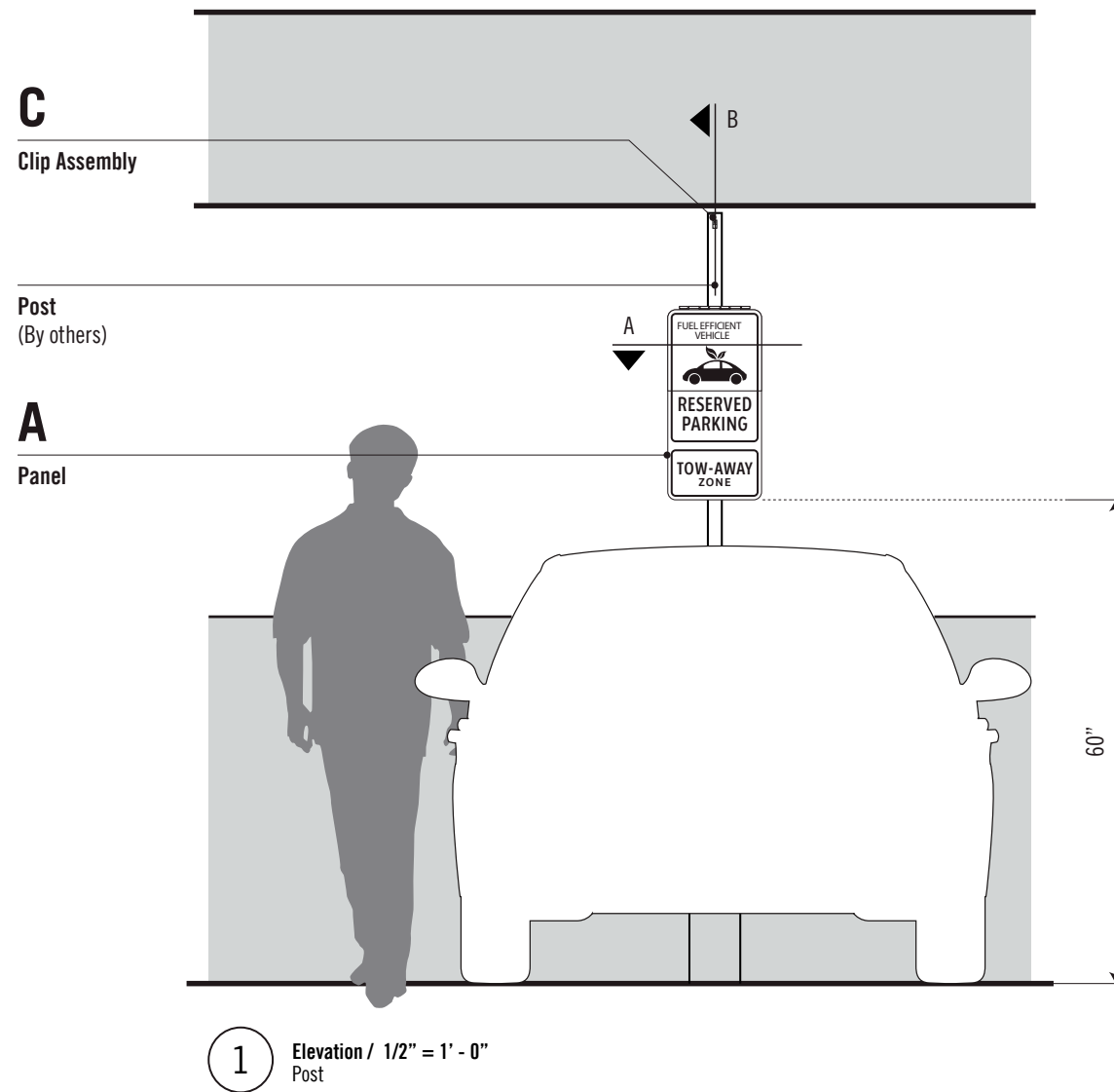

B Section Detail / NTS
Clip Assembly

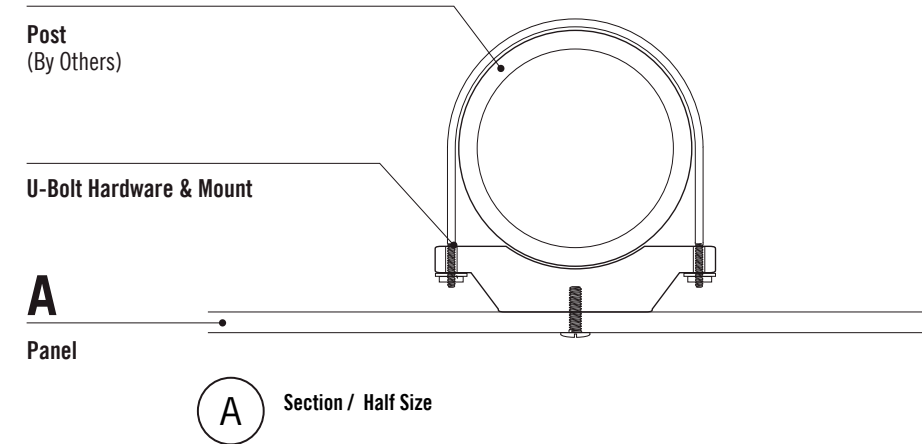

NOTE: Taken from DFW International Airport Headquarters document dated March 17, 2014

Dimensions & shapes of all elements as shown on G3.G8a thru G3.G8b.

A Tactile Plaque:

Photopolymer Plaque, 0.25" thickness, w/ raised graphics and Grade 2 Braille. Buff returns smooth and even to eliminate tooling marks. Paint finish all surfaces as indicated.

Typography:
Clearview Hwy 2-W, 0.625" Cap Height (Based on "E"), Kerned -25%. Interline spacing as indicated.

Symbol: 0.75" Height, Rule: 0.0625"

Installation:
Concealed 3M VHB tape & silicone mount flush to wall adjacent to latch side of door. Locate 58" to centerline of plaque from finished floor, 2" from door frame. At outswinging door locations maintain distance specified in DOJ 2010 ADA Standards for Accessible Design.

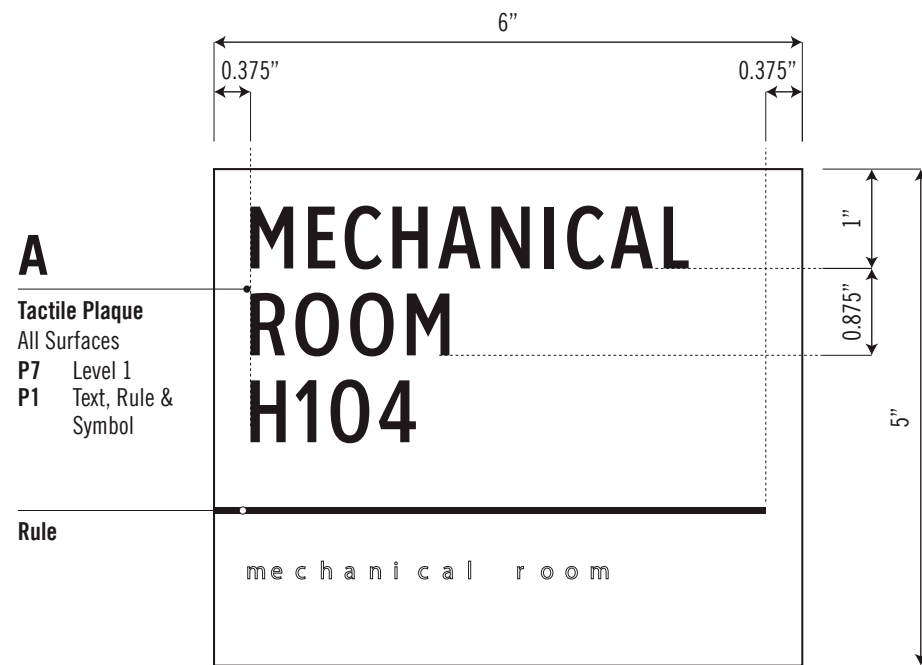

1 Elevation / Half Size

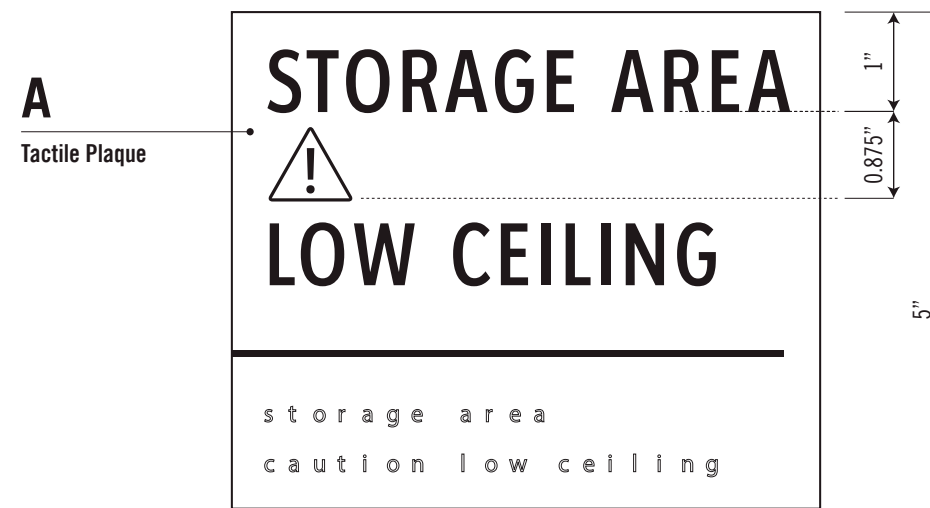

2 Elevation / Half Size

NOTE: Taken from DFW International Airport Headquarters document dated March 17, 2014

Dimensions & shapes of all elements as shown on G3.G8a thru G3.G8b.

A

Tactile Plaque

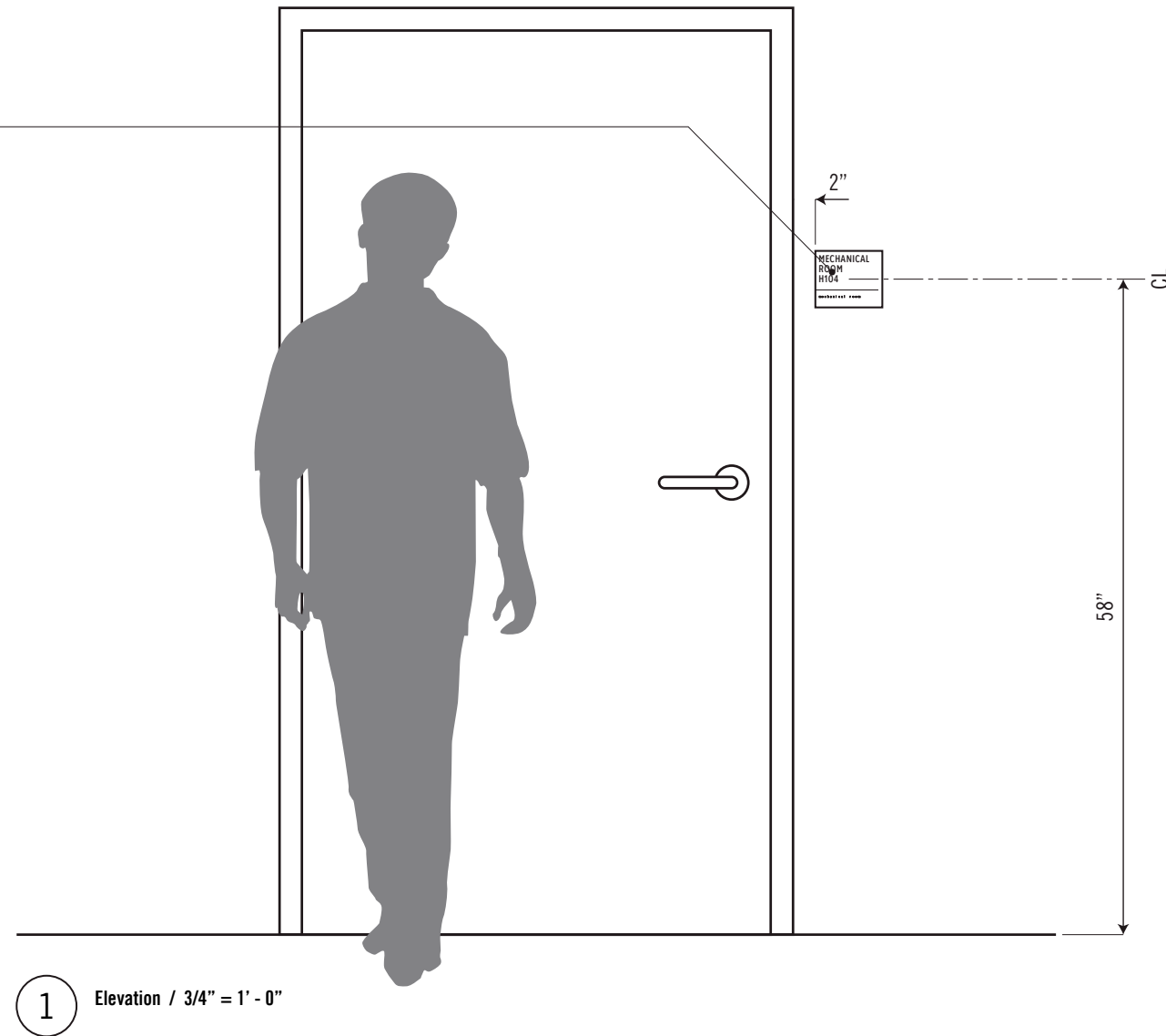

NOTE: Taken from DFW International Airport Headquarters document dated March 17, 2014

WARNING:

This record contains Sensitive Security Information that is controlled under 49 CFR parts 15 and 1520. No part of this record may be disclosed to persons with a "need to know," as defined in 49 CFR parts 15 and 1520, except with the written permission of the Administrator of the Transportation Security Administration or the Secretary of Transportation. Unauthorized release may result in civil penalty or other action. For U.S. government agencies, public disclosure is governed by 5 U.S.C. 552 and 49 CFR parts 15 and 1520.

Dimensions & shapes of all elements as shown on G3.G9a.

A Panel:
Acrylic plate of 0.125" thickness, cut to size. Buff returns smooth and even to eliminate any tooling marks. Paint all surfaces as indicated. Graphics to be screened first surface.

Typography:
Messages: Clearview Hwy 3-W, 1" Cap Height (Based on "E"), Interline spacing as indicated. Kerned -50%.
Numeral: Clearview Hwy 5-W, 5" Cap Height (Based on "E").

Symbols:
Arrow: 3" Height; Star: 3" Height

B Tactile Plaque:
Photopolymer Plaque, 0.0625" thickness, w/ raised graphics and Grade 2 Braille. Buff returns smooth and even to eliminate tooling marks. Paint finish all surfaces as indicated. Laminate to panel with concealed adhesive, align edges.

Typography:
Clearview Hwy 5-W, 0.625" Cap Height (Based on "E").

Grade 2 Braille:
Height, kerning & leading per requirements of the DOJ's 2010 ADA Standards for Accessible Design.

Installation:
Concealed VHB tape & silicone mount holder assembly flush to wall at 56" above finish floor to bottom of sign. Locate on wall outside stair where sign is visible. Owner to field verify position.

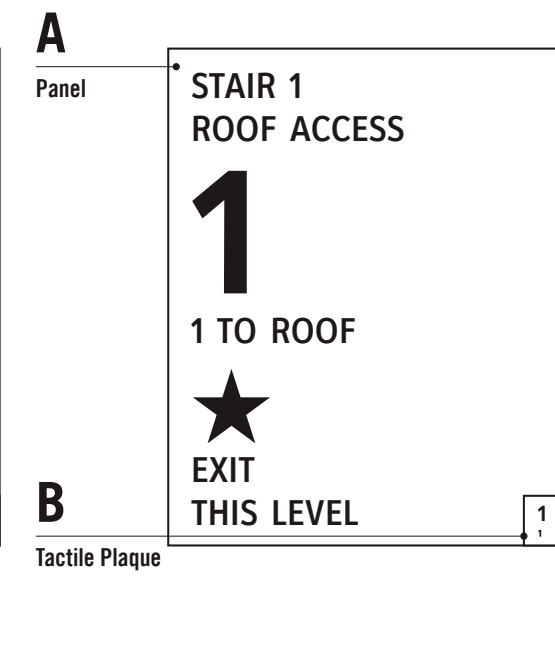
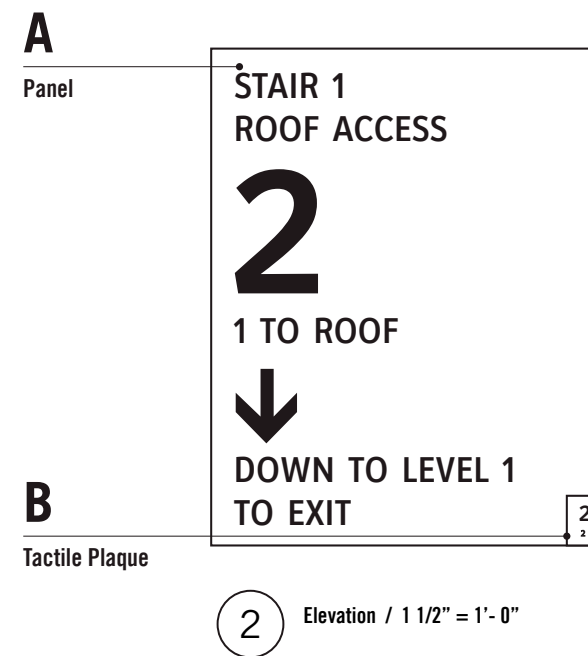
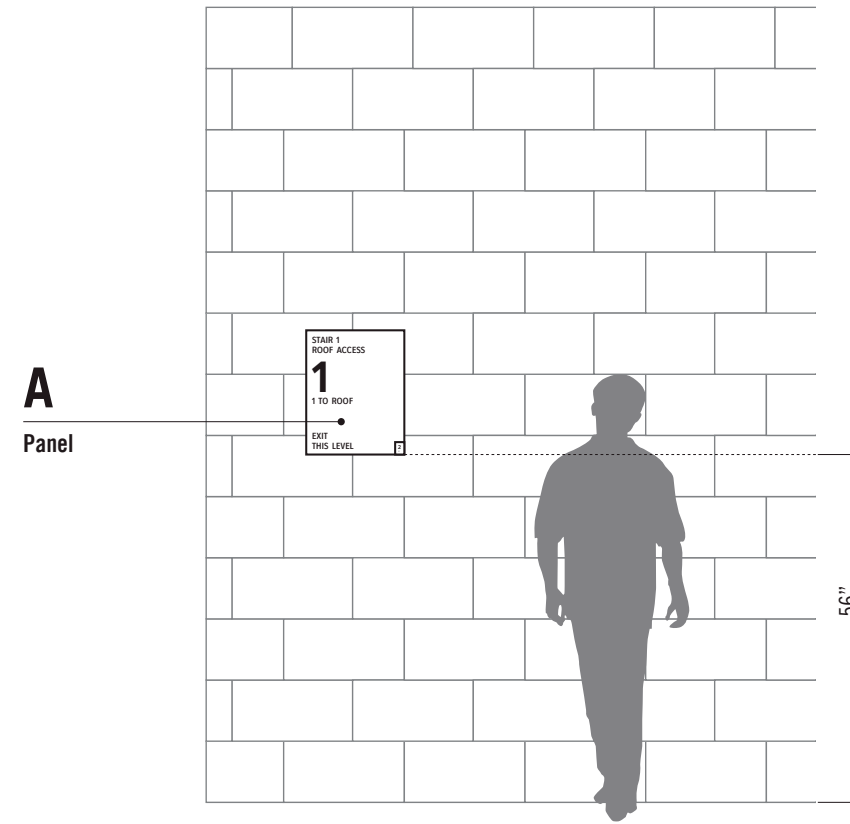
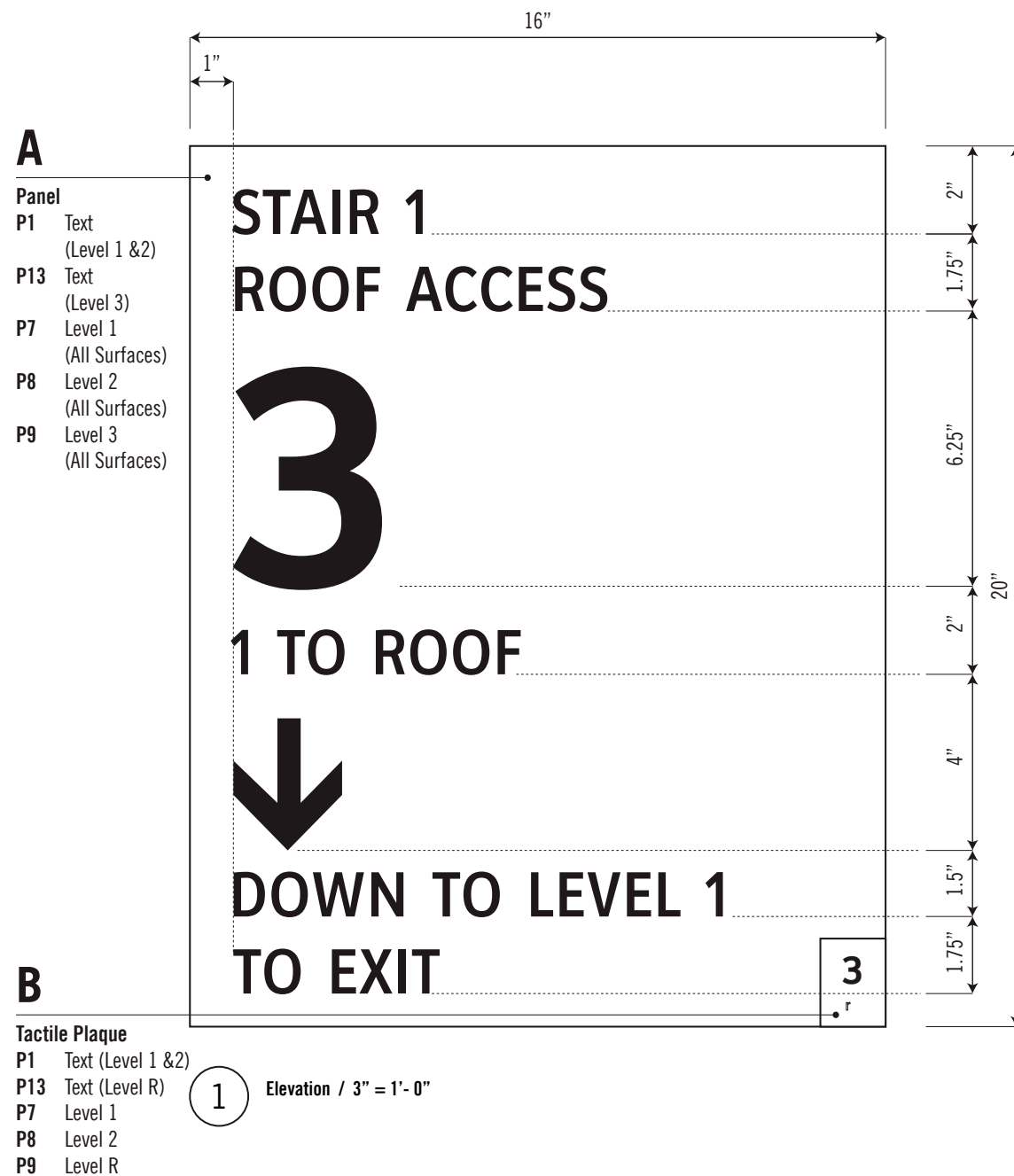

NOTE: Taken from DFW International Airport Headquarters document dated March 17, 2014

Dimensions & shapes of all elements as shown on G3.G10a.

A Panel:
0.125" Thick acrylic, cut to size. Buff returns smooth and even to eliminate tool marks. Paint all surfaces as indicated. Graphics to be screened first surface.

Typography:
For "Flight Level": Clearview Hwy 2-B, 1" Cap Height (Based on "E"), Kerned -50%. For Level Indicator: Clearview Hwy 3-B, 1.5" Cap Height (Based on "1"), Kerned -50%. For Map Key & Warning Information: Clearview Hwy 2-B, 0.5" Cap Height, Kerned -50%. Interline spacing as indicated. For "In Case of Fire...": Clearview Hwy 2-B, 0.625" Cap Height, Kerned -50%. Interline spacing as indicated.

Symbols:
(FS): 2.5" Height, (FES): 0.5" Height, (YAH): 0.5" Height, (SR): 0.5" Height, (RR): 0.5" Height.

Map Art:
Signage Contractor is responsible for developing ALL map layouts, including determination of primary and secondary paths of egress based on Life Safety Plans (A1 Series), and is responsible for producing ALL digital artwork required to produce signage. Submit ALL finished map artwork to Designer for review and approval of map style and content. Submit ALL finished map artwork to project Fire Marshall and/or other appropriate governing agency within the project jurisdiction for review and approval for fire code compliance. Provide hard copy of Fire Marshall's signed approval to Owner for record keeping. Refer to sheet G3.MSa for map style guide and minimal requirements for map art.

Installation:
Concealed 3M VHB tape and silicone mount flush to wall 1 1/2" above existing elevator call button plate. Designer verify and confirm location in field.

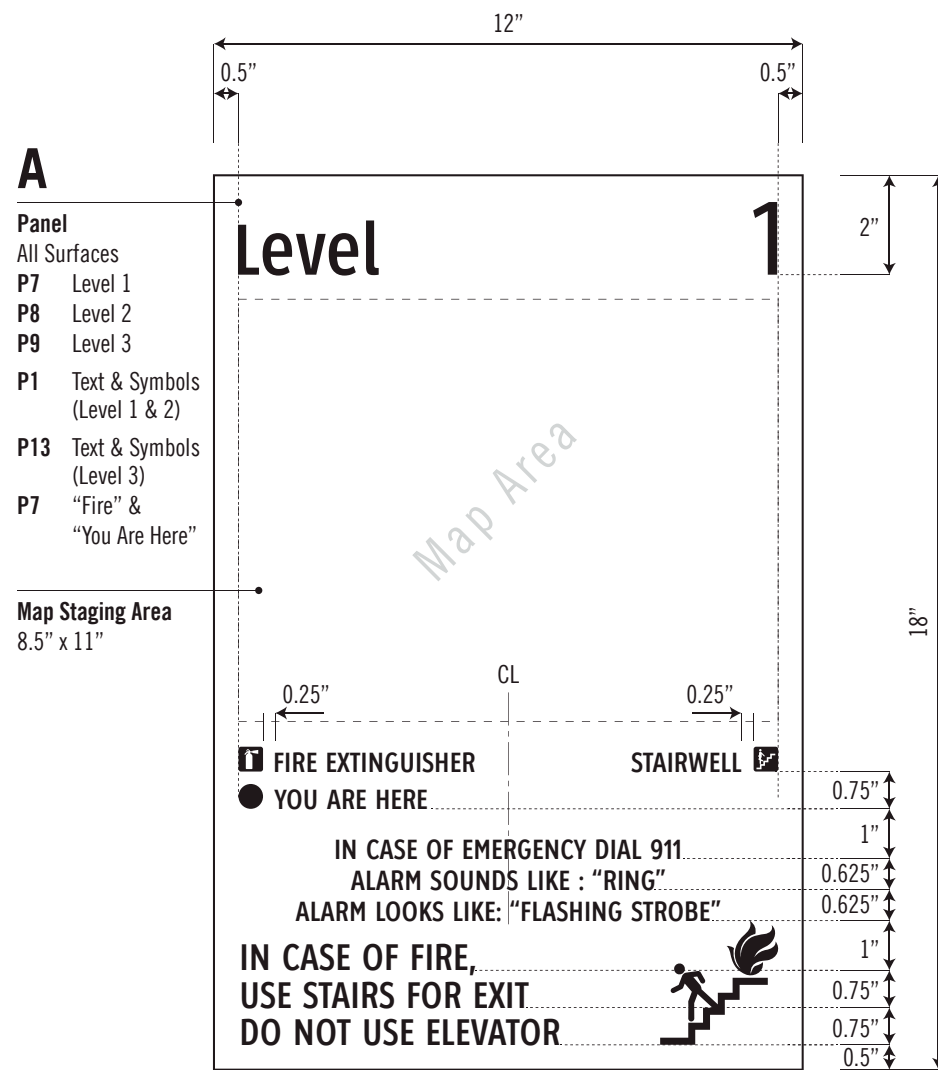

1 Elevation / 3" = 1'-0"

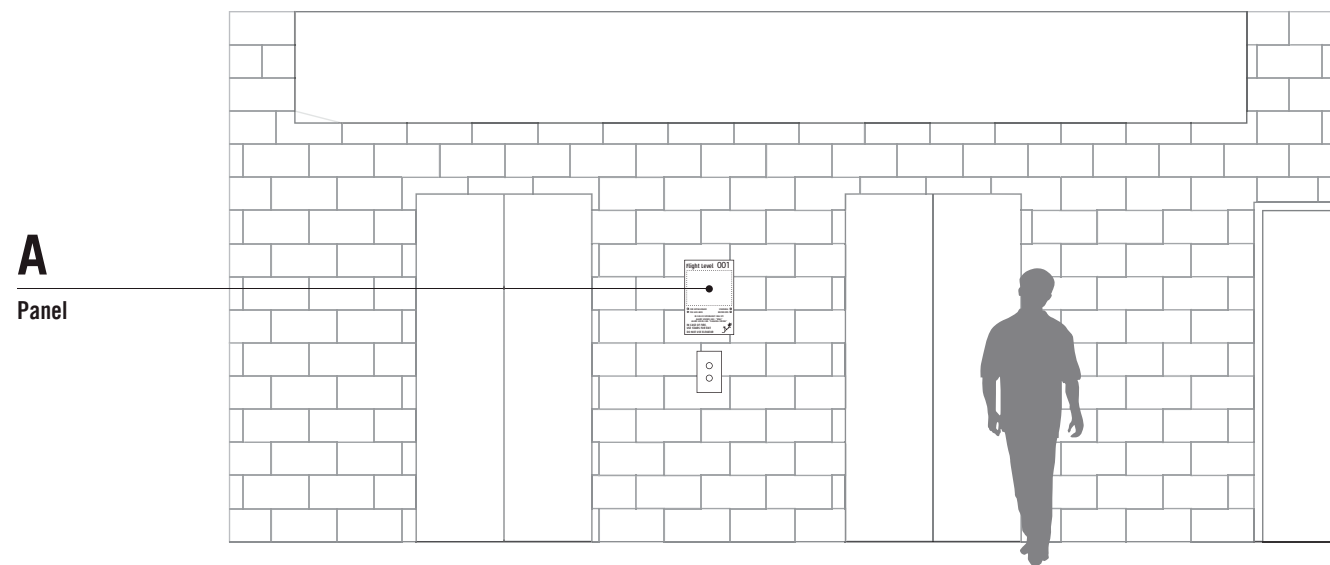

2 Elevation / 1/4" = 1'-0"

NOTE: Taken from DFW International Airport Headquarters document dated March 17, 2014

Dimensions & shapes of all elements as shown on G3.G11a.

A Panel:
 Aluminum Panel of 0.090" thickness. Cut to shape and buff returns smooth and even to eliminate tooling marks. Paint all surfaces as indicated. Apply 3M Computer Cut Vinyl Graphics to first surface.

Typography
 For "Reserved Parking", Clearview Hwy 2-W, 1.75" Cap Height (Based on "E"), Interline Spacing of 2.5". For "Tow-Away" and "Van", Clearview Hwy 2-B, 1.5" Cap Height (Based on "E"). For "Zone" and "Accessible", Clearview Hwy 5-W, 1" Cap Height (Based on "E").

Installation:
 Mechanical Attachment of panel to existing post with U-bolt Hardware and Mount Sign contractor responsible to field verify all as build conditions to determine hardscape or softscape.

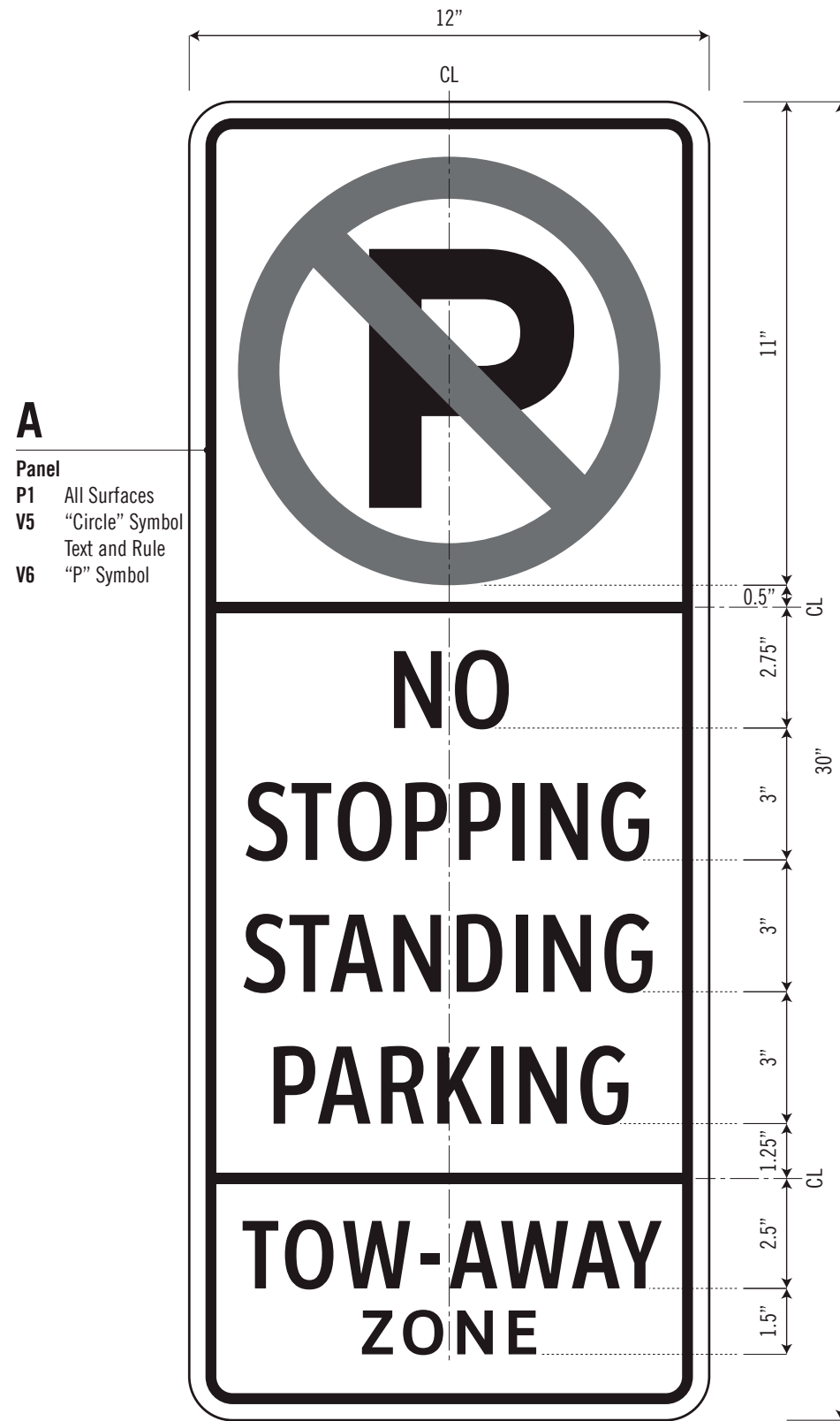

- A**
- Panel**
- P1** All Surfaces
- V5** "Circle" Symbol
- V6** "P" Symbol

1 Elevation / 3" = 1' - 0"

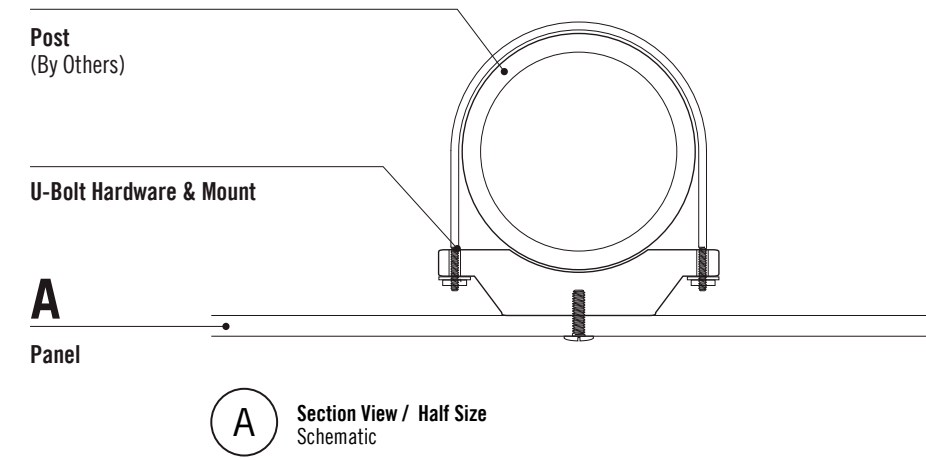

A Section View / Half Size Schematic

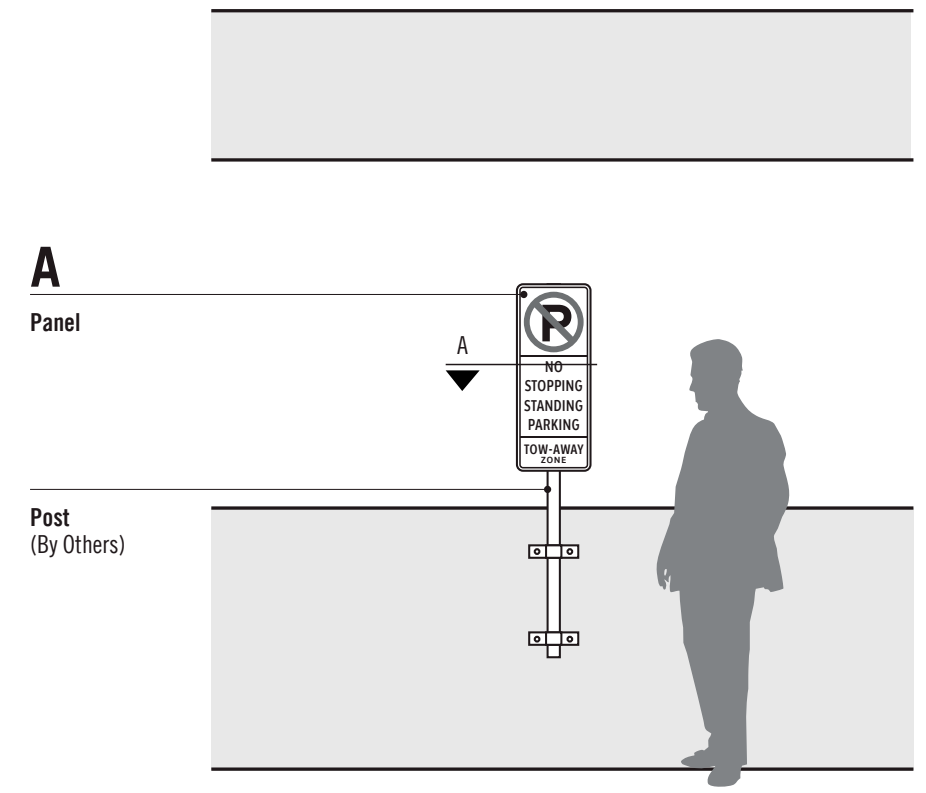

2 Elevation / 3/8" = 1' - 0"

NOTE: Taken from DFW International Airport Headquarters document dated March 17, 2014

Dimensions & shapes of all elements as shown on G3.G13a.

A Panel:
 Aluminum Panel of 0.125" thickness. Cut to size and buff returns smooth and even to eliminate tooling marks. Apply 3M Computer Cut Vinyl Graphics to first surface. Paint finish all surfaces as indicated.

Installation:
 Concealed 3M VHB tape and silicone mount flush to wall 4" above existing fire extinguisher cabinet.

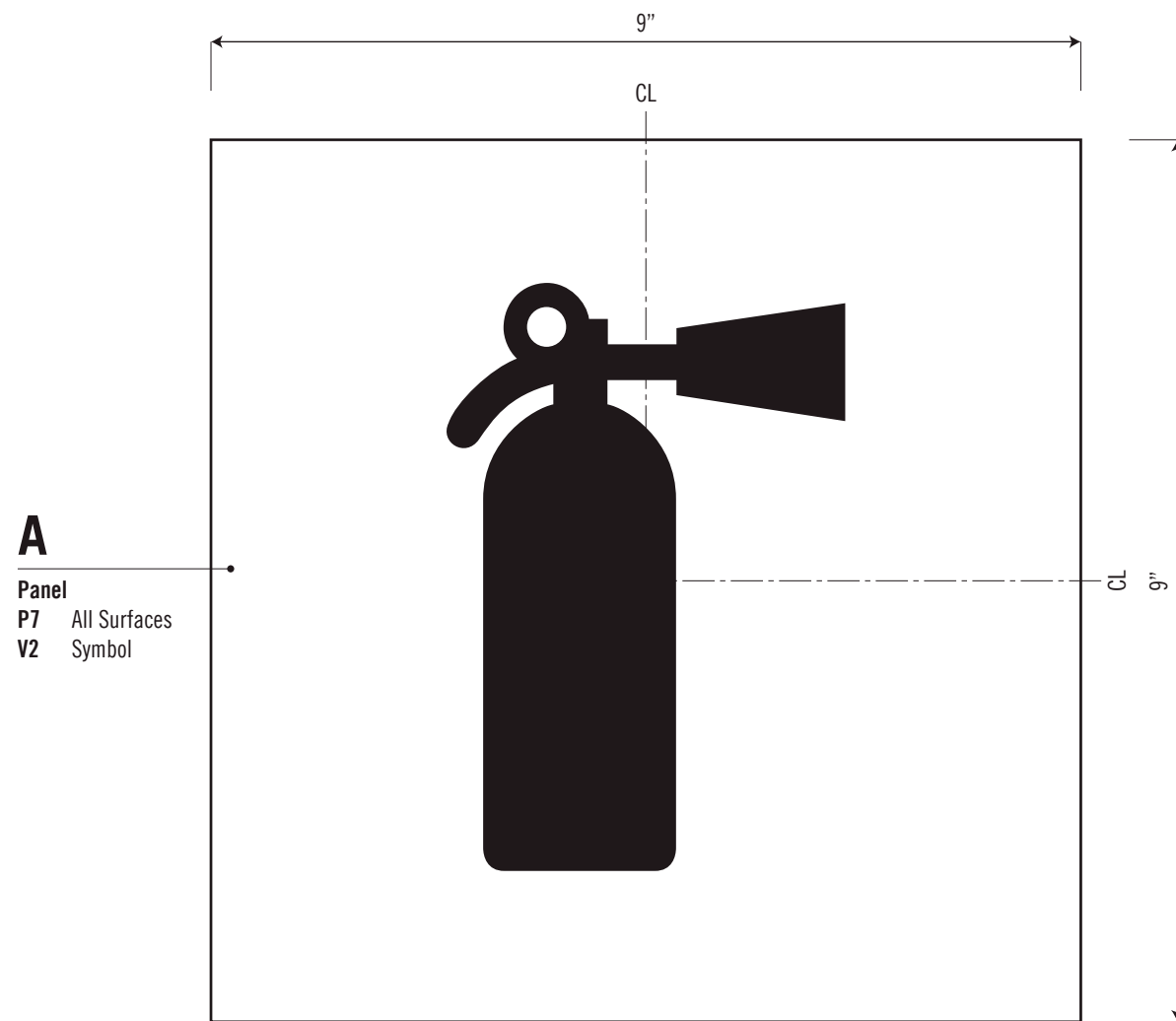

A
 Panel
 P7 All Surfaces
 V2 Symbol

1 Elevation / Half Size

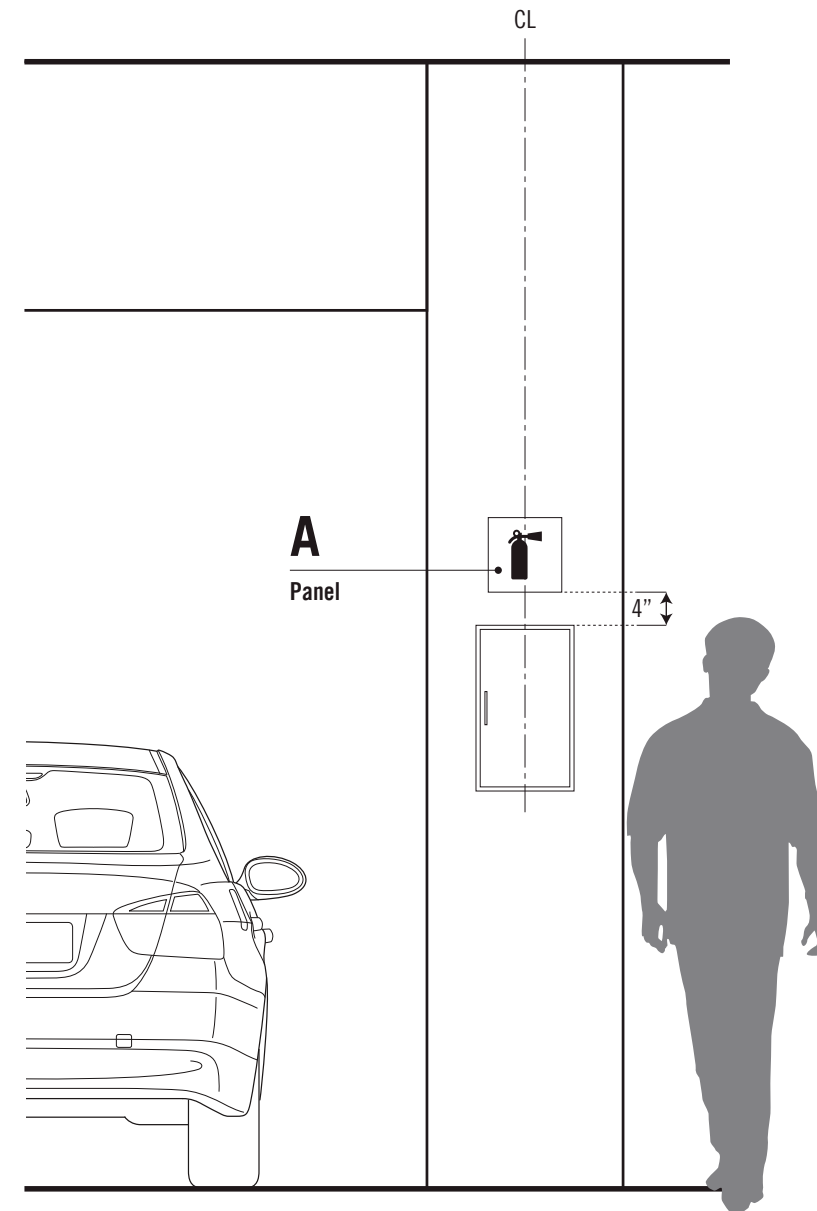

2 Elevation / 1/2" = 1'-0"

NOTE: Taken from DFW International Airport Headquarters document dated March 17, 2014

11.0

11.0 APPENDIX: BOARD FACILITIES

-11.1 Sign Standards

Dimensions & shapes of all elements as shown on G3.B7a.

A Tactile Plaque:
Photopolymer Plaque, 0.25" thickness, w/ raised graphics and Grade 2 Braille. Buff returns smooth and even to eliminate tooling marks. Paint finish all surfaces as indicated.

Typography:
Clearview Text Medium, 0.625" Cap Height (Based on "E"), Kerned +25%. Interline spacing of 1".

Grade 2 Braille:
Height, kerning & leading per requirements of the Texas Accessibility Standard (TAS), American with Disabilities Act (ADA).

B Accent:
Acrylite Colorless 0A000 B0 textured acrylic panel, 0.125" thickness, cut to size, texture to be first surface. Rout grooves into face, no greater than 0.0625" configured to accept Bars. Polish returns clear, smooth and even, backpaint as indicated. Laminate to Tactile Plaque using concealed adhesive sheeting, aligning edges.

C Bars:
Aluminum Bars 0.25" wide by 0.125" thick, cut to length. Buff edges smooth and even to eliminate any tooling marks. Finish as indicated. Apply thin and even matte finish clearcoat to all surfaces and laminate to Accent with concealed adhesive.

Installation:
Concealed 3M VHB tape & silicone mount flush to wall adjacent to latch side of door. Locate 58" to centerline of plaque from finished floor, 2" from door frame. At outswinging door locations maintain distance specified in the Texas Accessibility Standard (TAS), American with Disabilities Act (ADA).

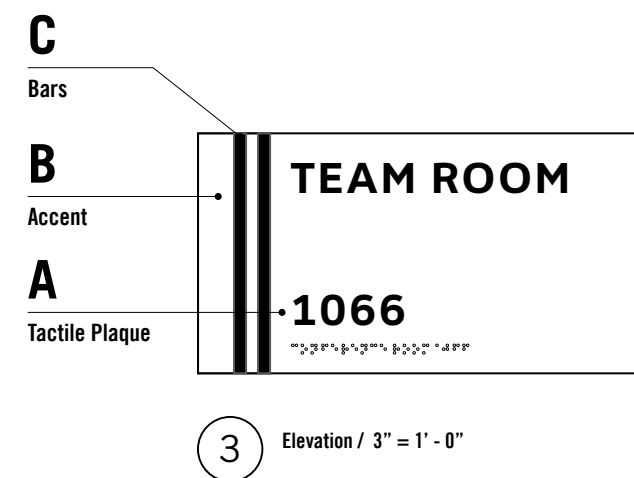
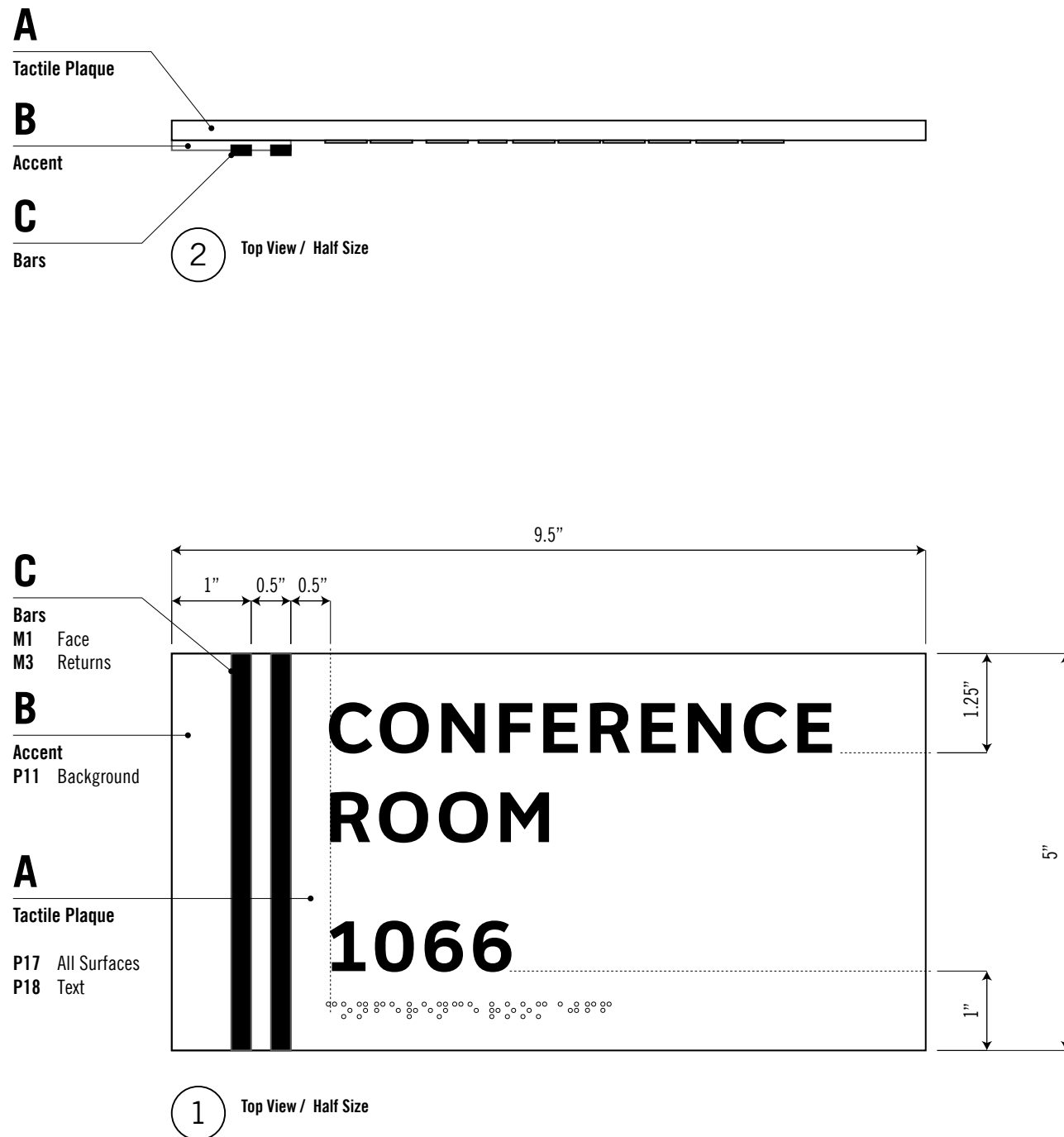

Dimensions & shapes of all elements as shown on G3.B10a.

A Tactile Plaque:
Photopolymer, 0.125" thickness, w/ raised graphics and Grade 2 Braille. Buff returns smooth and even to eliminate any tooling marks. Finish all surfaces as indicated.

Typography:
Clearview Text Medium, 0.625" Cap Height (Based on "E"), Kerned +25%. Interline spacing of 1".

Grade 2 Braille:
Height, kerning & leading per requirements of the Texas Accessibility Standard (TAS), American with Disabilities Act (ADA).

B Name Plate:
Acrylic sheet, 0.125" thickness, cut to size. Buff returns smooth and even to eliminate any tooling marks. Paint finish all surfaces as indicated. Screen print text to first surface. Configured with concealed magnetic tape.

Typography:
Name: Clearview Text Bold, 0.75" Cap Height (Based on "E"); Title & Department: Clearview Text Book, 0.625" Cap Height (Based on "E"), Interline spacing as indicated.

C Bars:
Aluminum Bars 0.25" wide by 0.125" thick with vertical brush finish, cut to length. Buff edges smooth and even to eliminate any tooling marks. Apply thin and even matte finish clearcoat to all surfaces and laminate to Accent with concealed adhesive.

D Accent:
Acrylite Colorless 0A000 BO textured acrylic panel, 0.125" thickness, cut to size. Rout grooves into face, no greater than 0.0625" configured to accept Bars. Polish returns clear, smooth and even, eliminating any tooling marks and backpaint at second surface. Laminate to Tactile Plaque using concealed adhesive sheeting, aligning edges.

E Backplate:
Acrylic sheet, 0.25" thickness, cut to size. Buff returns smooth and even to eliminate tooling marks. Paint finish all surfaces as indicated. Apply thin tin @name plate location only. Configured to hold name plate.

Installation:
Concealed 3M VHB tape & silicone mount flush to wall adjacent to latch side of door. Locate 58" to centerline of plaque from finished floor, 2" from door frame. At outswinging door locations maintain distance specified in the Texas Accessibility Standard (TAS), American with Disabilities Act (ADA).

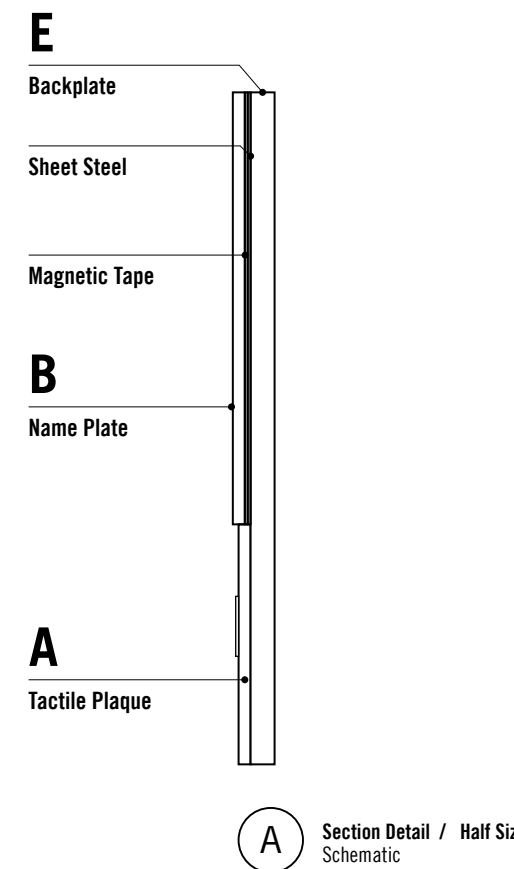
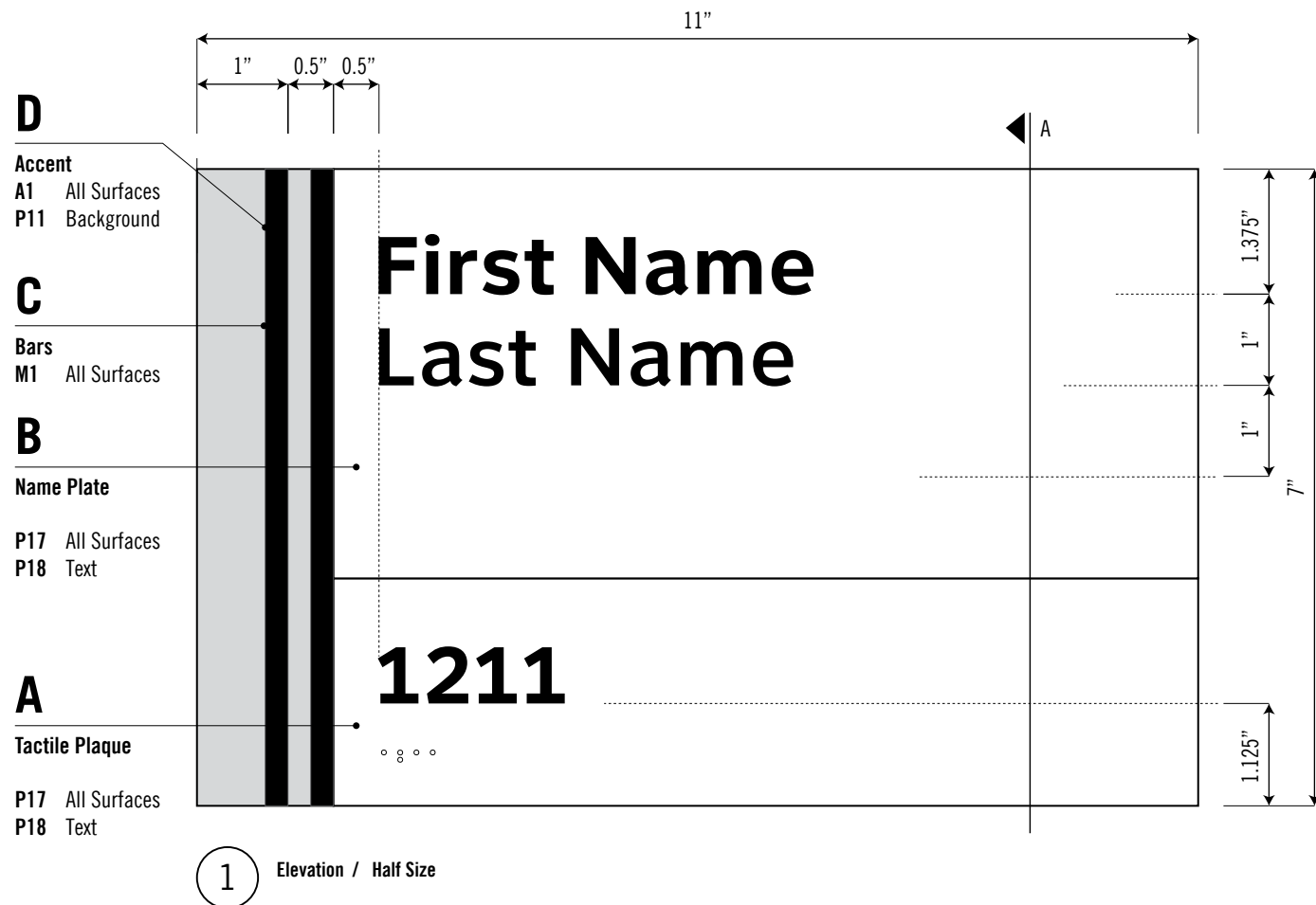
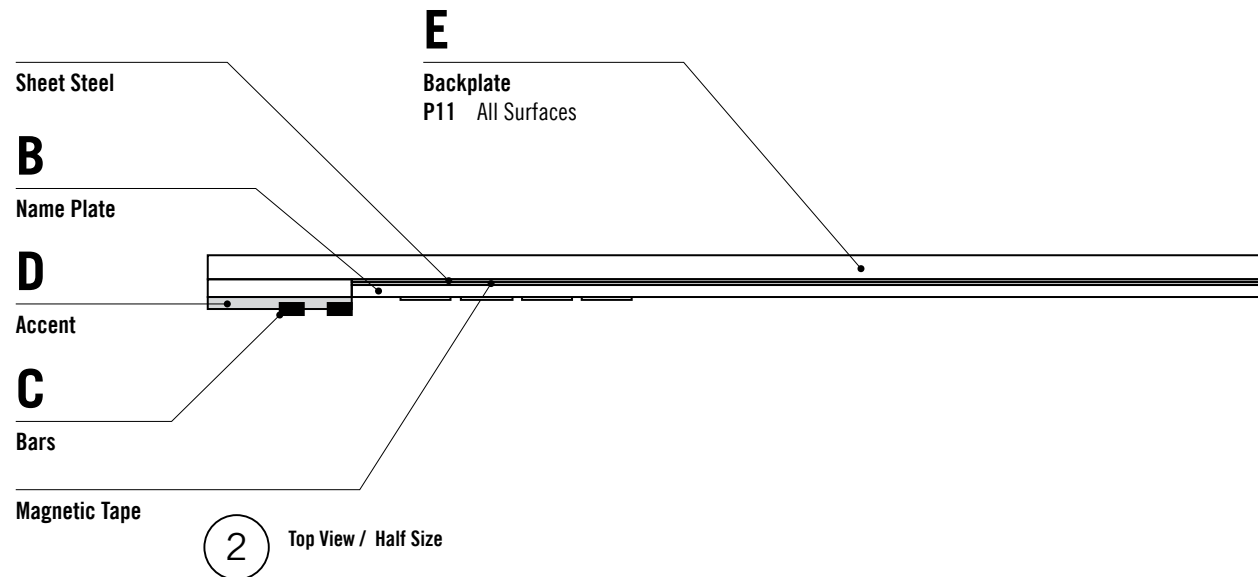

Dimensions & shapes of all elements as shown on G3.B11a.

A Tactile Plaque:
 Photopolymer Plaque, 0.25" thickness, w/ raised graphics and Grade 2 Braille. Buff returns smooth and even to eliminate tooling marks. Paint finish all surfaces as indicated.

Typography:
 Clearview Text Medium, 0.625" Cap Height (Based on "E"), Kerned +25%. Interline spacing as indicated.

Grade 2 Braille:
 Height, kerning & leading per requirements of the Texas Accessibility Standard (TAS), American with Disabilities Act (ADA).

Installation:
 Concealed 3M VHB tape & silicone mount flush to wall adjacent to latch side of door. Locate 58" to centerline of plaque from finished floor, 2" from door frame. At outswinging door locations maintain distance specified in the Texas Accessibility Standard (TAS), American with Disabilities Act (ADA).

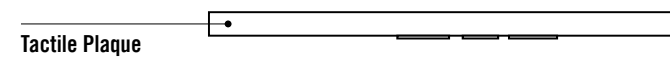

2 Top View / Half Size

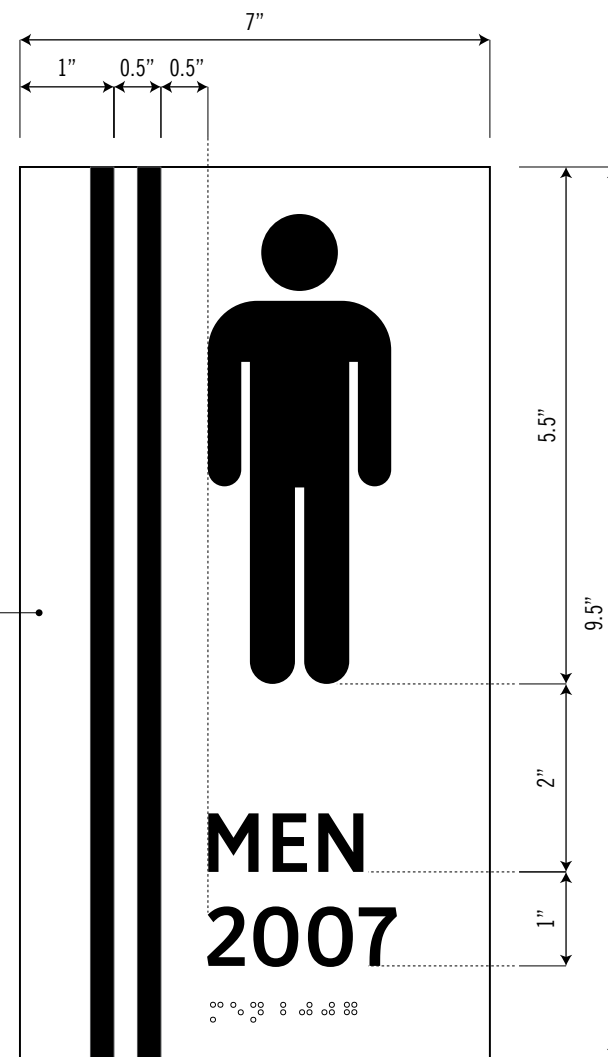

A
 Tactile Plaque
 P17 All Surfaces
 P18 Text
 P14 Bars

1 Elevation / Half Size
 Style A

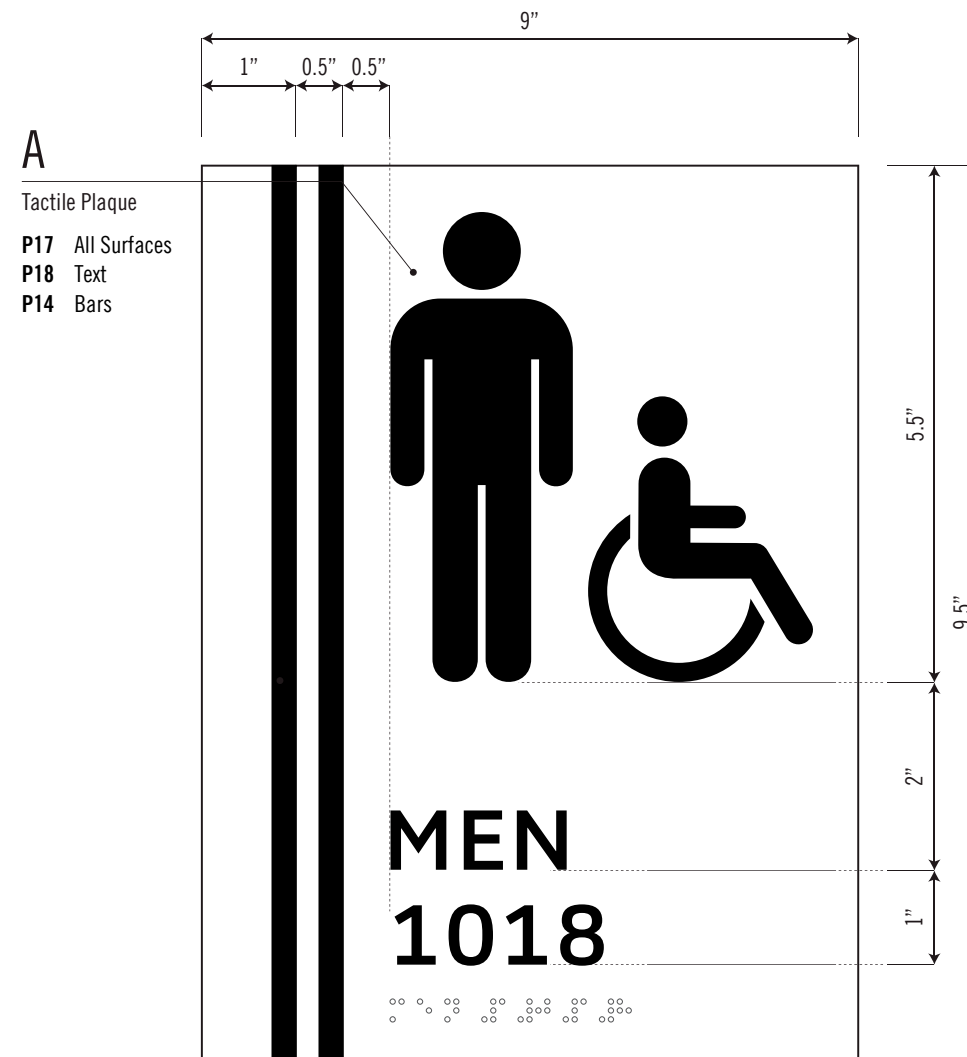

A
 Tactile Plaque
 P17 All Surfaces
 P18 Text
 P14 Bars

3 Elevation / Half Size
 Style A

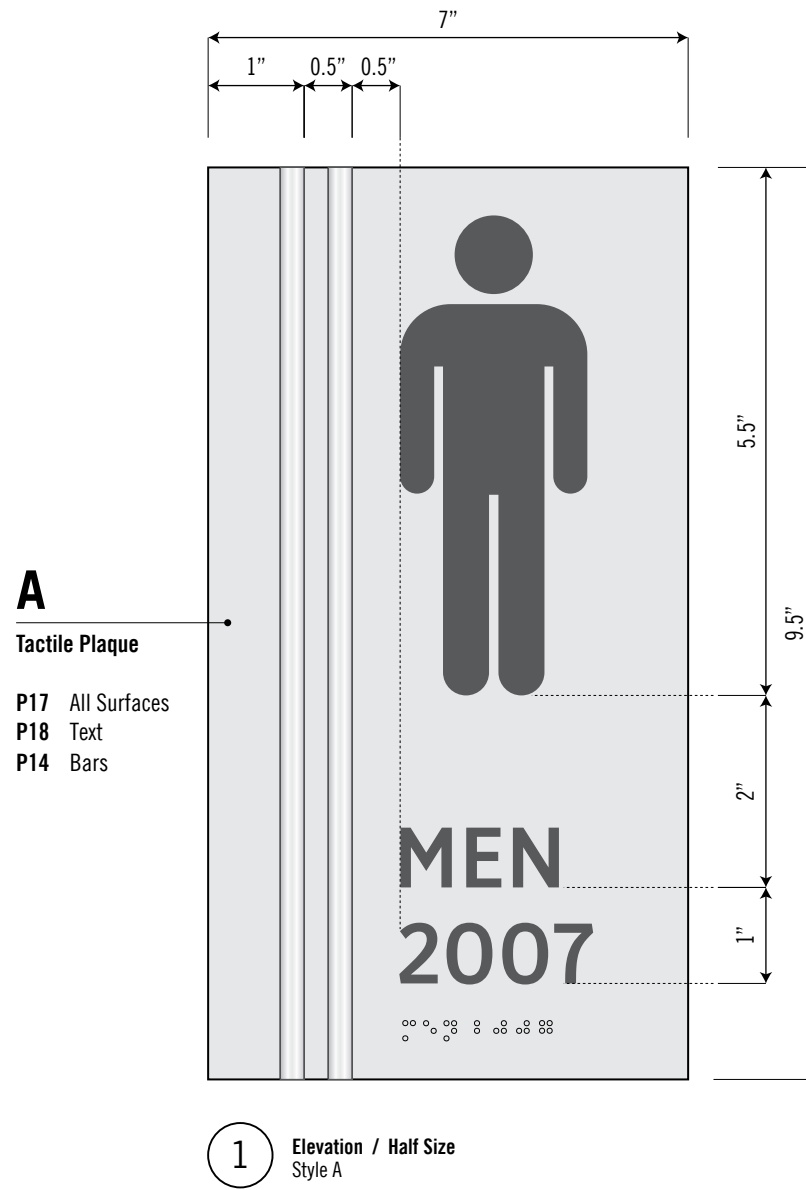

Dimensions & shapes of all elements as shown on G3.B13a.

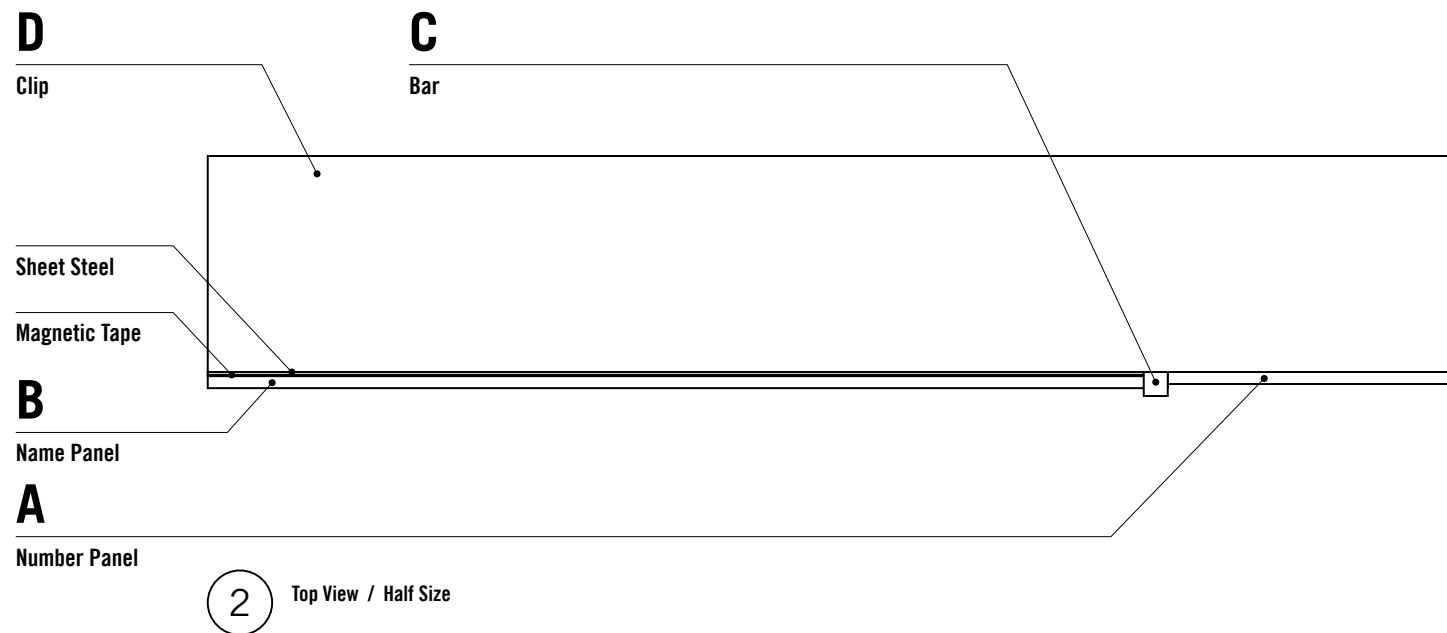

A Number Plaque:
Acrylic plaque, 0.125" thickness, cut to size. Buff returns smooth and even to eliminate any tooling marks. Paint finish all surfaces as indicated. Screen print graphics to first surface.

Typography:
Clearview Text Bold, 0.625" Cap Height (Based on "E")

B Name Plate:
Acrylic plaque, 0.125" thickness, w/ screen printed graphics. Buff returns smooth and even to eliminate tooling marks. Paint finish all surfaces as indicated. Held in place with concealed magnetic tape and sheet steel.

Typography:
Name: Clearview Text Bold, 0.625" Cap Height (Based on "E"); Title & Department: Clearview Text Book, 0.375" Cap Height (Based on "E"), Interline spacing as indicated.

C Bar:
Aluminum Bars 0.25" wide by 0.125" thick with vertical brush finish, cut to length. Buff edges smooth and even to eliminate any tooling marks. Apply thin and even matte finish clearcoat to all surfaces and laminate to Accent with concealed adhesive.

D Clip:
Aluminum form of 0.125" thickness, cut to size. Buff edges smooth and even to remove any and all tool marks. To be formed to shape to fit on cubicle walls. Cubicle wall dimensions to be determined. Architect to supply dimensions and specifications on cubicle furniture prior to fabrication.

Installation:
Install over existing cubicle wall. Sign fabricator to verify conditions prior to fabrication.

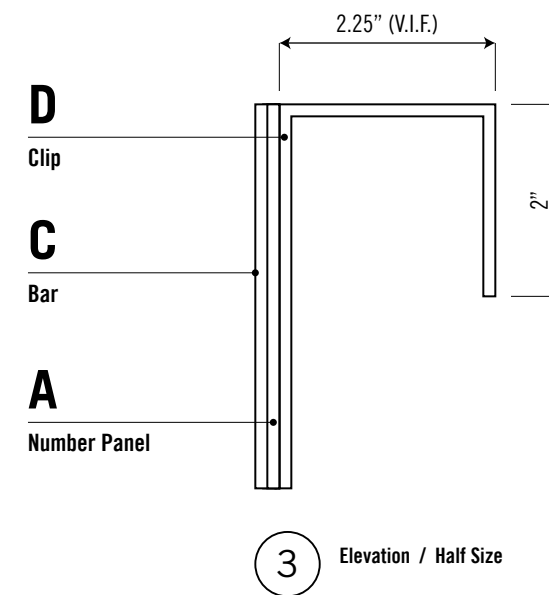
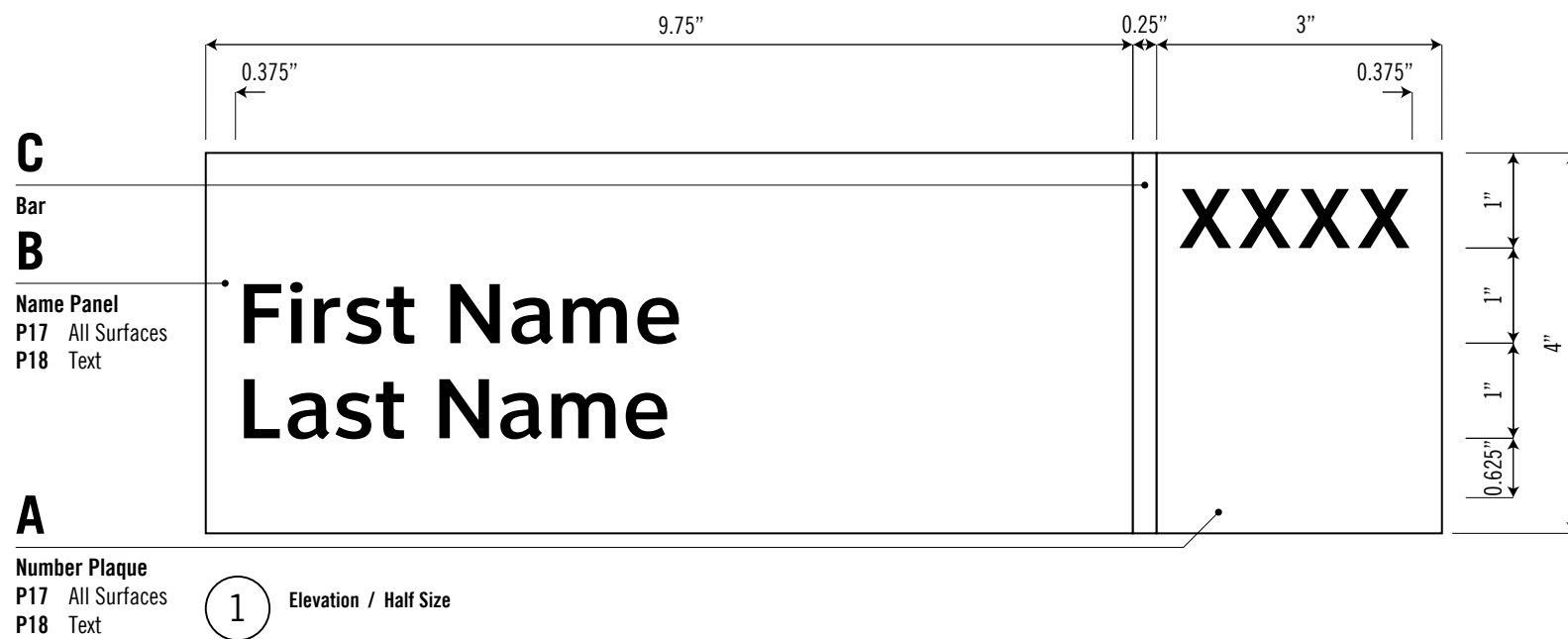

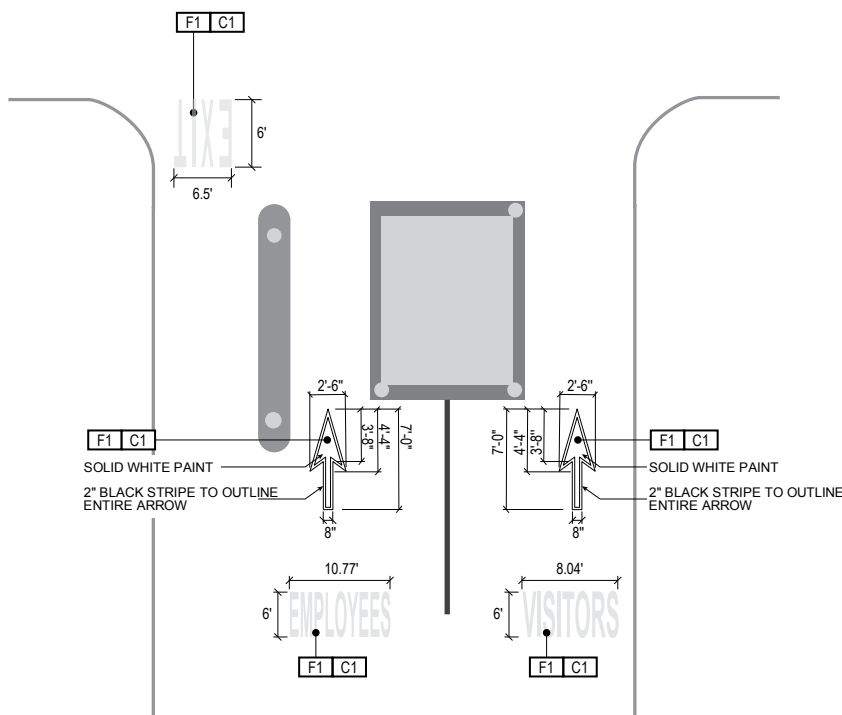

1 PLAN VIEW
Scale: NTS

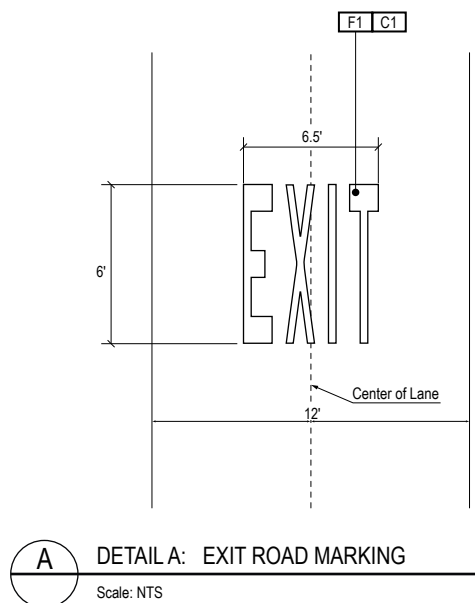

A DETAIL A: EXIT ROAD MARKING
Scale: NTS

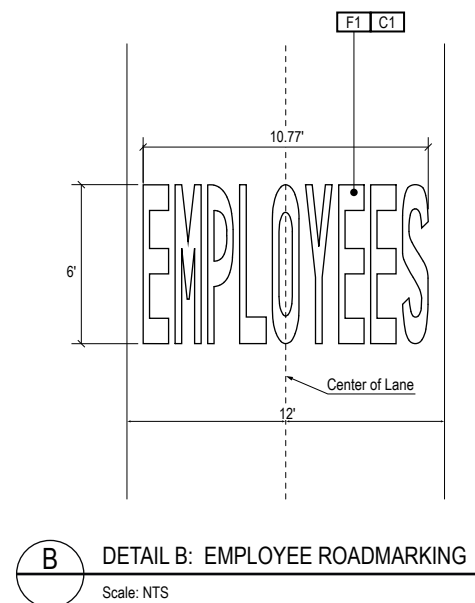

B DETAIL B: EMPLOYEE ROADMARKING
Scale: NTS

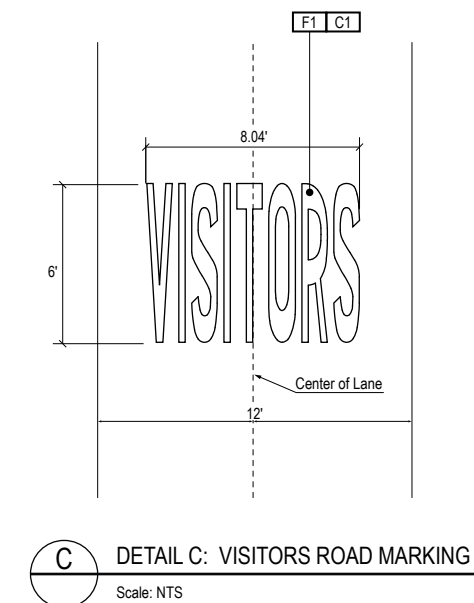

C DETAIL C: VISITORS ROAD MARKING
Scale: NTS

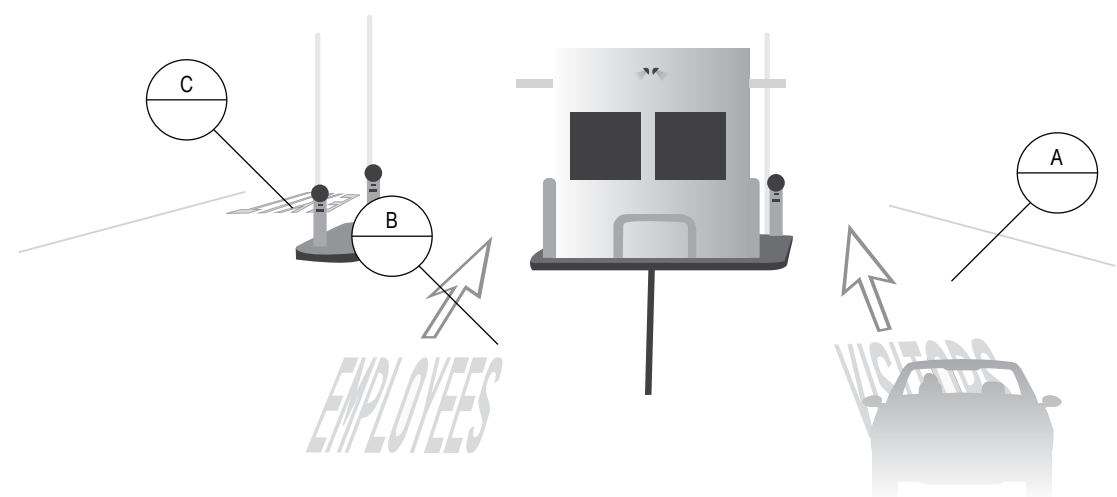

2 ELEVATION - ENTRANCE VIEW
Scale: NTS

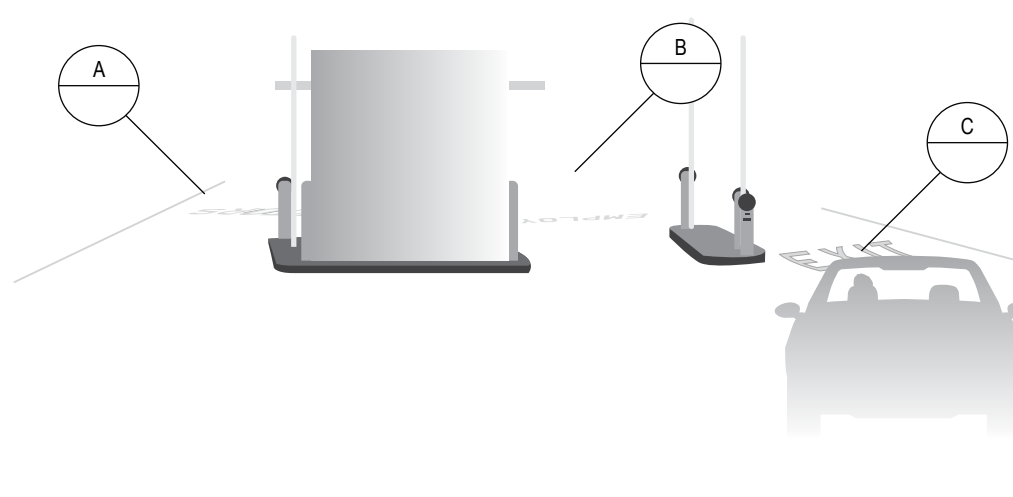

3 ELEVATION - EXIT VIEW
Scale: NTS

PAVEMENT MARKING NOTES

Colors shown are for reference only, and are subject to the limitations of the printing process and / or variance of electronic RGB screen displays. Refer to color system swatches and/or final finish samples for accurate reference.

Messages shown here are typical placeholders only.

All dimensions are approximate, where necessary, field verify for accuracy.

Pavement marking letters, numerals, symbols, and arrows shall be installed in accordance with the design details in the Pavement Markings chapter of the "Standard Highway Sign Designs for Texas" book.

FABRICATION NOTES (GENERAL DESIGN INTENT)

F1 PAVEMENT MARKINGS

COLORS:

C1 White: PMS White C, Type DMS-8200 Traffic Paint

Reference for print material: Texas Manual on Uniform Traffic Control Devices (TMUTCD)

WARNING:

This record contains Sensitive Security Information that is controlled under 49 CFR parts 15 and 1520. No part of this record may be disclosed to persons with a "need to know," as defined in 49 CFR parts 15 and 1520, except with the written permission of the Administrator of the Transportation Security Administration or the Secretary of Transportation. Unauthorized release may result in civil penalty or other action. For U.S. government agencies, public disclosure is governed by 5 U.S.C. 552 and 49 CFR parts 15 and 1520.

LEVEL 1	DPS Field Operations Support Services & Records Holding Facility, Crime Lab, & Sally Port Evidence
LEVEL 2	Special Services Investigations FBI Information Technology Chief's Suite Project Support Fire Services & Administration

Elevator Directory

Dimensions & shapes of all elements as shown on G3.B2a.

A Textured Panel:

Textured acrylic panel of 0.125" thickness, Acrylite Colorless 0A000 B0, cut to size. Buff returns smooth and even to eliminate any tooling marks. Texture to be second surface. Text to be screen printed to first surface (non-textured surface) as indicated.

Typography:

"Flight Level" - Clearview Text Book, 0.3125" Cap Height (Based on "F"), Kerned 0.

"001", "002" - Clearview Text Medium, 1" Cap Height (Based on "1"), Kerned -50%.

B Digital Print:

Computer Cut digitally printed vinyl. First surface application. Sign Contractor responsible for color match digital print to indicated colors.

Installation:

Concealed 3M VHB tape & silicone mount flush to elevator cab wall. Sign contractor to field verify conditions prior to fabrication.

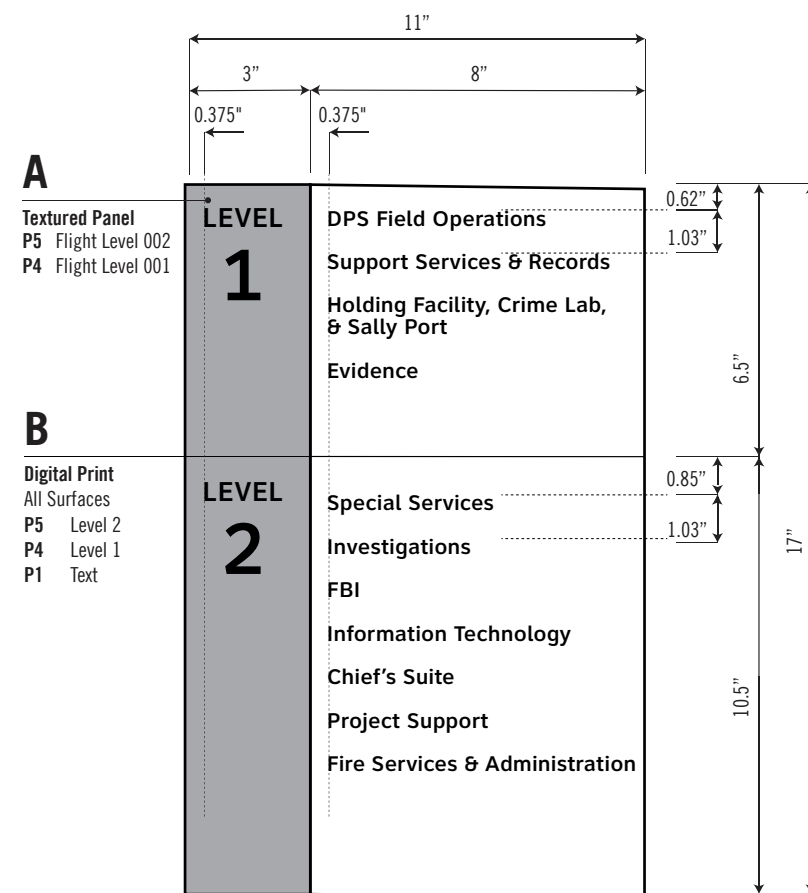

1 ELEVATION - ELEVATOR ENTRANCE VIEW

Scale: 3" = 1'-0"

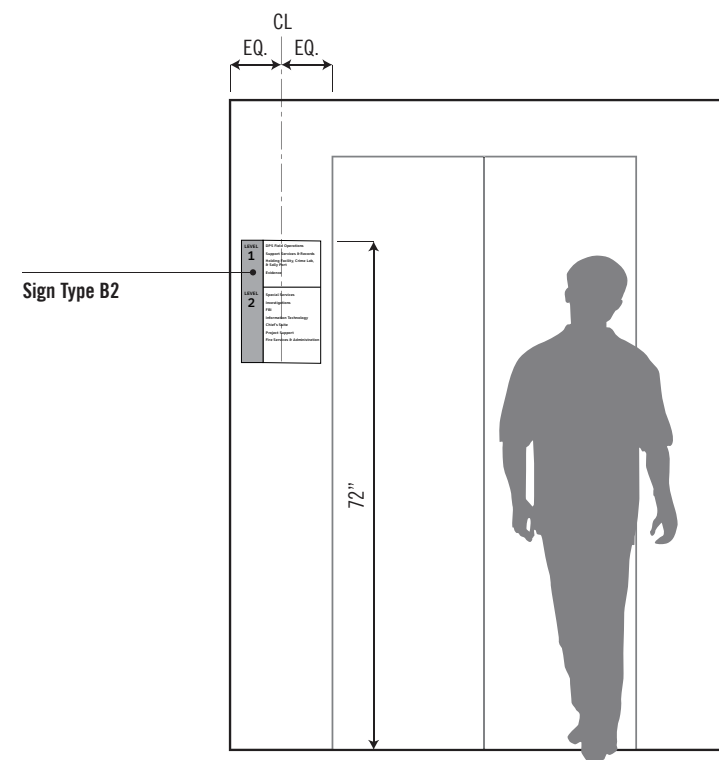

Sign Type B2

2 ELEVATION - ELEVATOR ENTRANCE VIEW

Scale: 1/2" = 1'-0"

WARNING:

This record contains Sensitive Security Information that is controlled under 49 CFR parts 15 and 1520. No part of this record may be disclosed to persons with a "need to know," as defined in 49 CFR parts 15 and 1520, except with the written permission of the Administrator of the Transportation Security Administration or the Secretary of Transportation. Unauthorized release may result in civil penalty or other action. For U.S. government agencies, public disclosure is governed by 5 U.S.C. 552 and 49 CFR parts 15 and 1520.



1 ELEVATION
Scale: NTS



A DETAIL A: Jail Signage
NTS

General Notes

Fabrication Specifications (for contractor)
Font: Clearview Medium
Font Size: 5/8", 7/8"
Sign Size: 12" x 18"
Finish: High res digital print on 3M control-tac vinyl first surface applied to 0.080" thick aluminum. Signs shall be mounted to door/brick with VHB double sided adhesive tape.

Materials/Colors

- Pantone 287 C
- White: 3M 7725-20 Opaque Matte White

Wall Signs

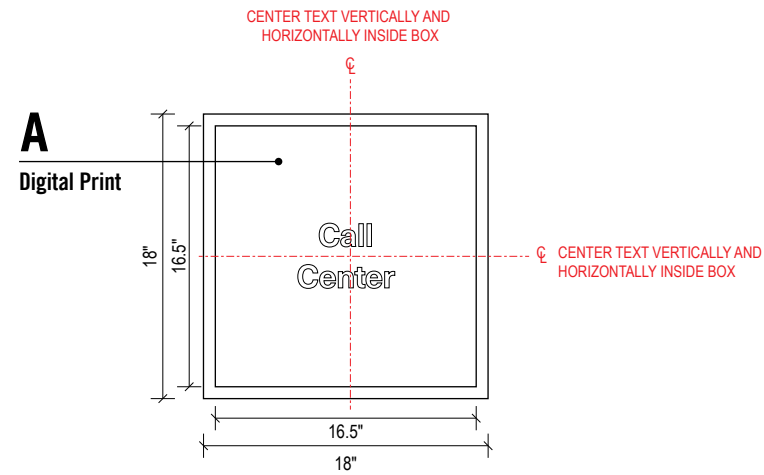

A Digital Print:

High res digital print on 3M control-tac vinyl with matte over laminate; first surface applied to all 3 faces of triangular sign topper.

Typography:

Neue Haas Unica Pro Bold, 1.375"

Colors:

1/8" thick brushed aluminum accents first surface applied to sign face.

- Pantone Cool Gray 10 C
- Pantone Cool Gray 1 C
- P2 Glimmer

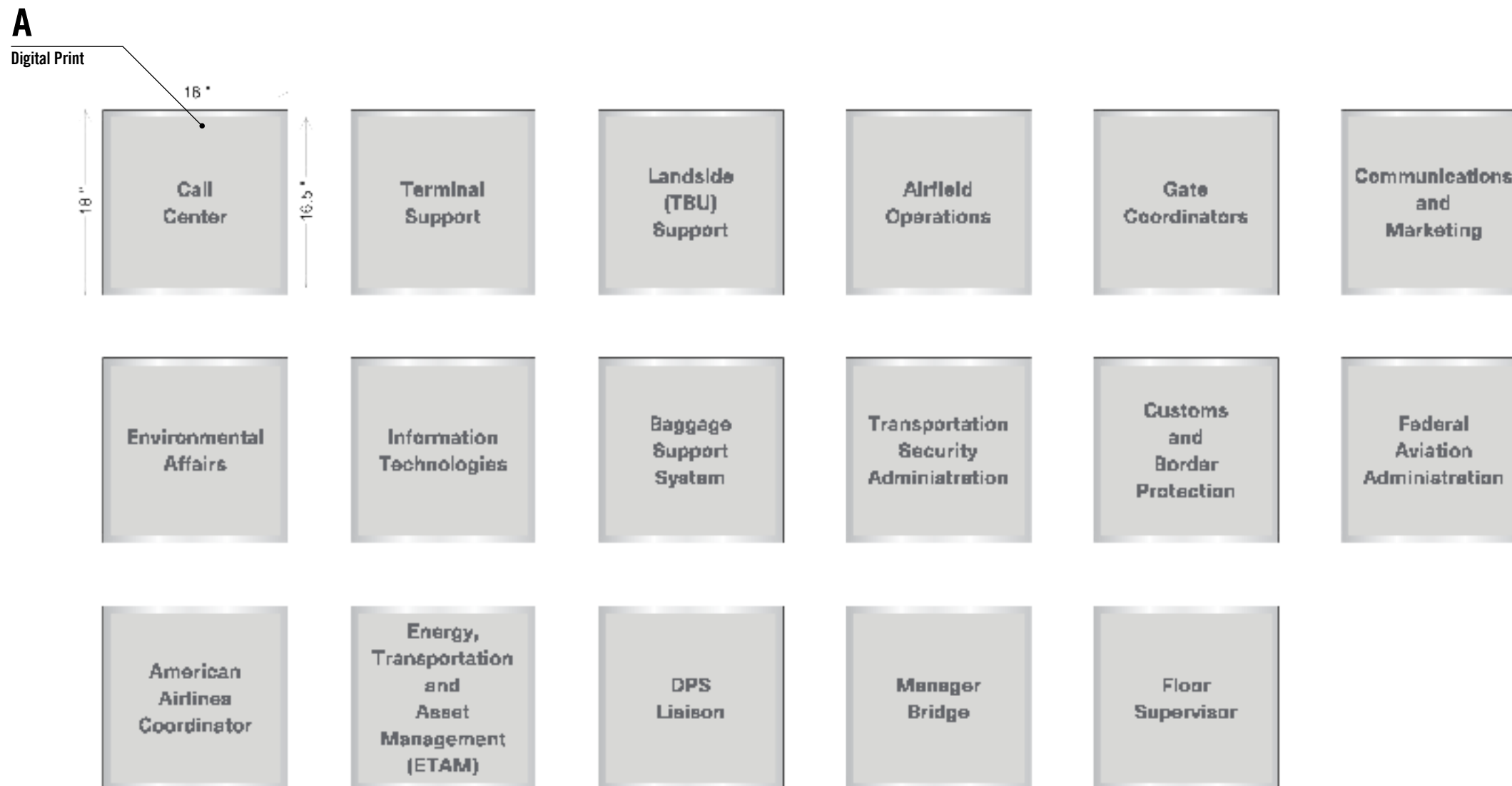

WARNING:

This record contains Sensitive Security Information that is controlled under 49 CFR parts 15 and 1520. No part of this record may be disclosed to persons with a "need to know," as defined in 49 CFR parts 15 and 1520, except with the written permission of the Administrator of the Transportation Security Administration or the Secretary of Transportation. Unauthorized release may result in civil penalty or other action. For U.S. government agencies, public disclosure is governed by 5 U.S.C. 552 and 49 CFR parts 15 and 1520.