

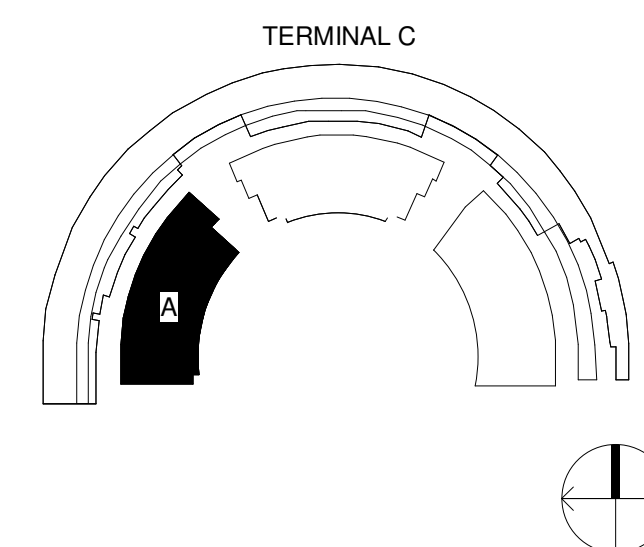

DFW AIRPORT

DFW TERMINAL C GARAGE AND ROADWAYS

PHASE 3

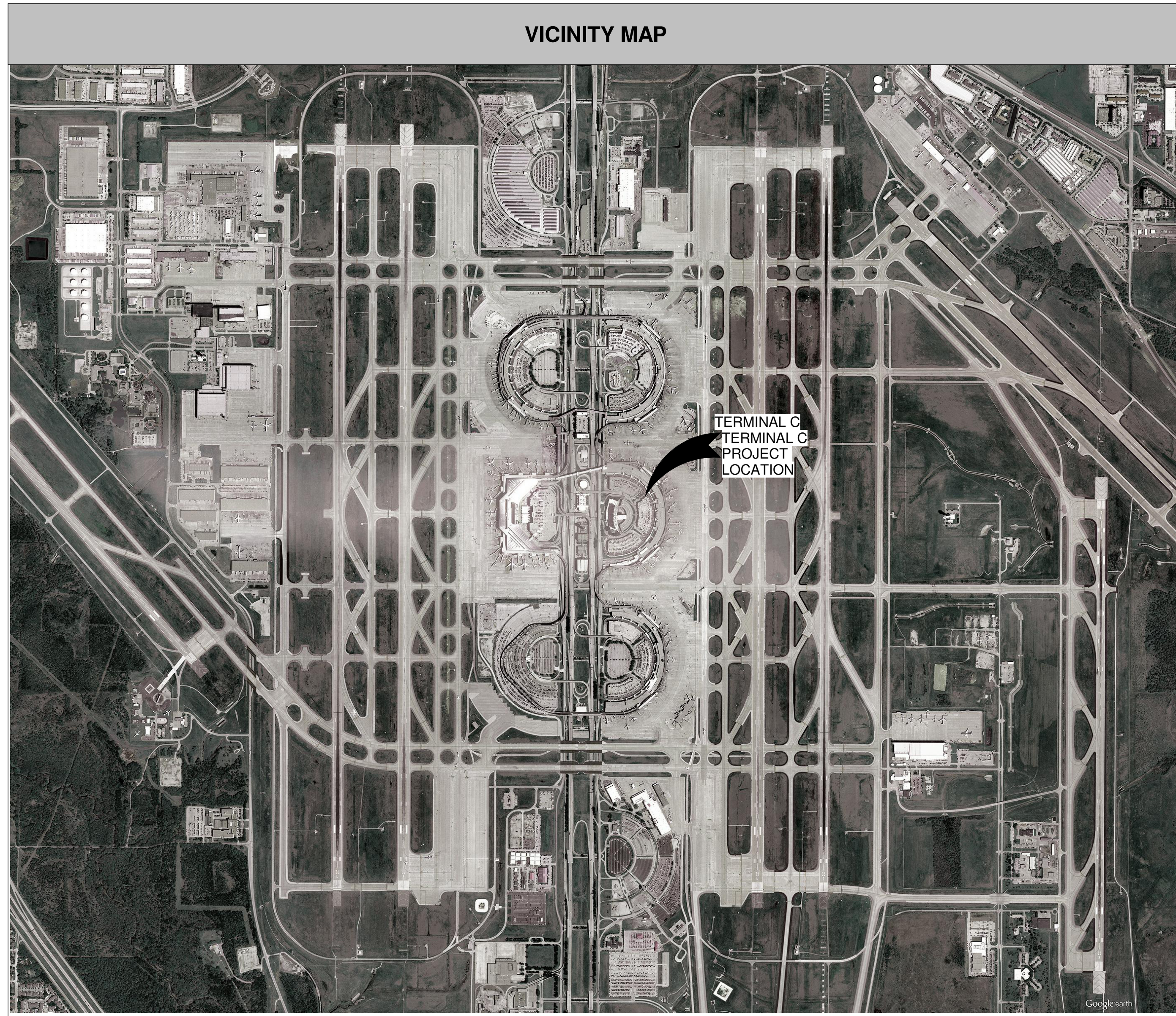

2330 N INTERNATIONAL PARKWAY
DFW AIRPORT, TX 75261

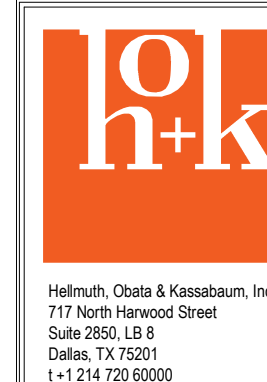

Hobbs, Clark & Koenigsmann, Inc.
777 North Marwood Street
Dallas, TX 75201
1-214-722-6000

DRAWN BY: RB
APPROVED BY: DM
ISSUE DATE: 2022-07-28

**NOT FOR BID OR
CONSTRUCTION**

NO.	DATE	DESCRIPTION
1	2022-07-28	100% ISSUED FOR PERMIT (IFP)

DFW TERMINAL C GARAGE AND ROADWAYS
COVER SHEET - PHASE ROADWAYS

PROJECT NUMBER: TFD-007

PERMIT NUMBER: B22-0023

SHEET NUMBER
GI004-900R

SCALE(S) AS NOTED ON THIS SHEET ARE BASED ON A FULL SIZE 30 X 42 SHEET.

SHEET INDEX - PHASE ROADWAYS

SHEET NUMBER	SHEET NAME				
		A21-188B - Terminal C Garage C	B22-0021 - Terminal C Garage B	B22-0022 - Terminal C Garage A	B22-0023 - Terminal C Roadway
00 - GENERAL					
GI004-900R	COVER SHEET - PHASE ROADWAYS				
GI014-900R	SHEET INDEX - PHASE ROADWAYS				
00 - GENERAL: 2					
D					
05 - CIVIL					
V-101-900R	SURVEY BENCHMARK PLAN (LOWER ROADWAY)				
V-102-900R	SURVEY BENCHMARK PLAN (LOWER ROADWAY)				
V-103-900R	SURVEY BENCHMARK PLAN (UPPER ROADWAY)				
V-104-900R	SURVEY BENCHMARK PLAN (UPPER ROADWAY)				
CD101-900R	DEMOLITION PLAN (LOWER ROADWAY)				
CD102-900R	DEMOLITION PLAN (LOWER ROADWAY)				
CD103-900R	DEMOLITION PLAN (UPPER ROADWAY)				
CD104-900R	DEMOLITION PLAN (UPPER ROADWAY)				
CS101-900R	DIMENSIONAL CONTROL PLAN (LOWER ROADWAY)				
CS102-900R	DIMENSIONAL CONTROL PLAN (LOWER ROADWAY)				
CS103-900R	DIMENSIONAL CONTROL PLAN (UPPER ROADWAY)				
CS104-900R	DIMENSIONAL CONTROL PLAN (UPPER ROADWAY)				
CS105-900R	OVERALL PHASING PLAN				
CP101-900R	PHASE 1 PAVING PLAN (LOWER ROADWAY)				
CP102-900R	PHASE 1 PAVING PLAN (UPPER ROADWAY)				
CP103-900R	PHASE 2 PAVING PLAN (LOWER ROADWAY)				
CP104-900R	PHASE 2 PAVING PLAN (LOWER ROADWAY)				
CP105-900R	PHASE 2 PAVING PLAN (UPPER ROADWAY)				
CP106-900R	PHASE 2 PAVING PLAN (UPPER ROADWAY)				
CP107-900R	PHASE 3 PAVING PLAN (LOWER ROADWAY)				
CP108-900R	PHASE 3 PAVING PLAN (UPPER ROADWAY)				
CP109-900R	PAVEMENT REPAIR PLAN				
CP110-900R	PAVEMENT REPAIR PLAN				
CP111-900R	PAVEMENT MARKING PLAN (LOWER ROADWAY)				
CP112-900R	PAVEMENT MARKING PLAN (LOWER ROADWAY)				
CP113-900R	PAVEMENT MARKING PLAN (UPPER ROADWAY)				
CP114-900R	PAVEMENT MARKING PLAN (UPPER ROADWAY)				
CP501-900R	PAVEMENT DETAILS				
CP502-900R	PAVEMENT DETAILS				
C-101-900R	CURBSIDE ALLOCATION - EXISTING (LOWER LEVEL)				
C-102-900R	CURBSIDE ALLOCATION - SUB PHASE 0 (LOWER LEVEL)				
C-103-900R	CURBSIDE ALLOCATION - PHASE 1A (LOWER LEVEL)				
C-104-900R	CURBSIDE ALLOCATION - PHASE 1B (LOWER LEVEL)				
C-105-900R	CURBSIDE ALLOCATION - PHASE 2A (LOWER LEVEL)				
C-106-900R	CURBSIDE ALLOCATION - PHASE 2B (LOWER LEVEL)				
C-107-900R	CURBSIDE ALLOCATION - PHASE 3A (LOWER LEVEL)				
C-108-900R	CURBSIDE ALLOCATION - PHASE 3B (LOWER LEVEL)				
C-109-900R	CURBSIDE ALLOCATION - FINAL (LOWER LEVEL)				
C-110-900R	CURBSIDE ALLOCATION - EXISTING (UPPER LEVEL)				
C-111-900R	CURBSIDE ALLOCATION - PHASE 1 & 6 (UPPER LEVEL)				
C-112-900R	CURBSIDE ALLOCATION - PHASE 2 & 7 (UPPER LEVEL)				
C-113-900R	CURBSIDE ALLOCATION - PHASE 3 & 8 (UPPER LEVEL)				
C-114-900R	CURBSIDE ALLOCATION - FINAL (UPPER LEVEL)				
C-115-900R	TRUCK TURNING MOVEMENTS				
CG101-900R	EROSION CONTROL PLAN (PHASE 1)				
CG102-900R	EROSION CONTROL PLAN (PHASE 2)				
CG103-900R	EROSION CONTROL PLAN (PHASE 2)				
CG104-900R	EROSION CONTROL PLAN (PHASE 3)				
CG105-900R	EROSION CONTROL PLAN (PHASE 3)				
CG106-900R	EROSION CONTROL PLAN (PHASE 3)				
CG501-900R	EROSION CONTROL DETAILS				
CG502-900R	EROSION CONTROL DETAILS (LOWER ROADWAY)				
CG503-900R	EROSION CONTROL DETAILS (UPPER ROADWAY)				
CT100-900R	PHASING NOTES AND TYPICAL SECTIONS				
CT101-900R	PHASE 1A MOT (LOWER ROADWAY)				
CT102-900R	PHASE 1A MOT (LOWER ROADWAY)				
CT103-900R	PHASE 1A MOT (LOWER ROADWAY)				
CT104-900R	PHASE 1B MOT (LOWER ROADWAY)				
CT105-900R	PHASE 1B MOT (LOWER ROADWAY)				
CT106-900R	PHASE 2A MOT (LOWER ROADWAY)				
CT107-900R	PHASE 2A MOT (LOWER ROADWAY)				
CT108-900R	PHASE 2B MOT (LOWER ROADWAY)				
CT109-900R	PHASE 2B MOT (LOWER ROADWAY)				
CT110-900R	PHASE 3A MOT (LOWER ROADWAY)				
CT111-900R	PHASE 3B MOT (LOWER ROADWAY)				
CT112-900R	PHASE 4A MOT (LOWER ROADWAY)				
CT113-900R	PHASE 4B MOT (LOWER ROADWAY)				
CT114-900R	STAGE 1 MOT (UPPER ROADWAY)				
CT115-900R	STAGE 2 MOT (UPPER ROADWAY)				
CT116-900R	STAGE 2 MOT (UPPER ROADWAY)				
CT117-900R	STAGE 3 MOT (UPPER ROADWAY)				
CT118-900R	STAGE 6 MOT (UPPER ROADWAY)				
CT119-900R	STAGE 7 MOT (UPPER ROADWAY)				
CT120-900R	STAGE 7 MOT (UPPER ROADWAY)				
CT121-900R	STAGE 8 MOT (UPPER ROADWAY)				
CT122-900R	DETOUR PLAN				
CT123-900R	MOT DETAILS				
CU101-900R	UTILITY DEMOLITION PLAN 1				
CU102-900R	UTILITY DEMOLITION PLAN 2				
CU103-900R	SITE UTILITY PLAN 1				
CU104-900R	SITE UTILITY PLAN 2				
CU105-900R	STORM SEWER DEMOLITION PLAN				
CU106-900R	STORM SEWER DEMOLITION PLAN				
CU107-900R	STORM SEWER PLAN				
CU108-900R	STORM SEWER PLAN				
CU109-900R	WATER SERVICE SHUT-OFF PLAN				
CU201-900R	STORM SEWER PROFILES				
CU202-900R	STORM SEWER PROFILES				
CU203-900R	STORM SEWER PROFILES				
CU204-900R	SANITARY PIPE PROFILES				
CU205-900R	WATER PIPE PROFILES 1				
CU206-900R	WATER PIPE PROFILES 2				
CU501-900R	WATER DETAILS 1				
CU502-900R	WATER DETAILS 2				
CU503-900R	SANITARY SEWER STRUCTURE AND WATER FITTING TABLES				
CU504-900R	SANITARY SEWER DETAILS				
CU505-900R	STORM SEWER DETAILS				
S-001-900R	LOADING DOCK RETAINING WALL STRUCTURAL NOTES				
SS501-900R	LOADING DOCK RETAINING WALL PROFILE AND DETAILS				
E-001-900R	ELECTRICAL ABBREVIATIONS AND SYMBOLS				
E-002-900R	ELECTRICAL GENERAL NOTES				
ED101-900R	ELECTRICAL DEMOLITION - LOWER ROADWAY, NORTH				
ED102-900R	ELECTRICAL DEMOLITION - LOWER ROADWAY, SOUTH				
ED103-900R	LIGHTING DEMOLITION - LOWER ROADWAY, NORTH				
ED104-900R	LIGHTING DEMOLITION - LOWER ROADWAY, SOUTH				
ED105-900R	LIGHTING DEMOLITION - UPPER ROADWAY, NORTH				
ED106-900R	LIGHTING DEMOLITION - UPPER ROADWAY, SOUTH				
ES101-900R	ELECTRICAL SITE PLAN, NORTH				
ES102-900R	ELECTRICAL SITE PLAN, SOUTH				
ES103-900R	ELECTRICAL NEW WORK - LOWER ROADWAY, NORTH				
ES104-900R	ELECTRICAL NEW WORK - LOWER ROADWAY, SOUTH				
ES105-900R	LIGHTING NEW WORK - LOWER ROADWAY, NORTH				
ES106-900R	LIGHTING NEW WORK - LOWER ROADWAY, SOUTH				
ES107-900R	LIGHTING NEW WORK - UPPER ROADWAY, NORTH				
ES108-900R	LIGHTING NEW WORK - UPPER ROADWAY, SOUTH				
ES201-900R	ELECTRICAL DUCT BANK PLAN AND PROFILE, NORTH				
ES202-900R	ELECTRICAL DUCT BANK PLAN AND PROFILE, SOUTH				
ES401-900R	GARAGES A AND B ELECTRICAL ENCLOSURE ENLARGED PLANS, NORTH				
ES402-900R	GARAGES C ELECTRICAL ENCLOSURE ENLARGED PLANS, SOUTH				
ES501-900R	ELECTRICAL DETAILS				
ES502-900R	ELECTRICAL DETAILS				
ES503-900R	ELECTRICAL DETAILS				
ES504-900R	DNCR DETAILS				
ES601-900R	POWER DISTRIBUTION SINGLE LINE DIAGRAM AND SWITCHGEAR ELEVATION - GARAGES A AND B				
ES602-900R	POWER DISTRIBUTION SINGLE LINE DIAGRAM AND SWITCHGEAR ELEVATION - GARAGE C				

SHEET INDEX - PHASE ROADWAYS

SHEET NUMBER	SHEET NAME				
		A21-188B - Terminal C Garage C	B22-0021 - Terminal C Garage B	B22-0022 - Terminal C Garage A	B22-0023 - Terminal C Roadway
ES603-900R	ELECTRICAL LIGHTING RISERS				
ES604-900R	ELECTRICAL SCHEDULES				
ES605-900R	ELECTRICAL SCHEDULES				
05 - CIVIL: 128					
06 - LANDSCAPE					
L-101-900R	LANDSCAPE PLAN AREA A				
L-102-900R	LANDSCAPE PLAN AREA B				
06 - LANDSCAPE: 2					
07 - STRUCTURAL					
S-040-900R	GENERAL NOTES - ROADWAY				
S-140-900R	ROADWAY OVERALL 3D VIEW & PLAN				
S-141-900R	ROADWAY FRAMING PLAN - GRIDS 5-12 & RAMP M (BOTTOM)				
S-142-900R	ROADWAY FRAMING PLAN - GRIDS 5-12 & RAMP M (TOP)				
S-143-900R	ROADWAY FRAMING PLAN - GRIDS 12-24 (BOTTOM)				
S-144-900R	ROADWAY FRAMING PLAN - GRIDS 12-24 (TOP)				
S-145-900R	ROADWAY FRAMING PLAN - GRIDS 24-34 (BOTTOM)				
S-146-900R	ROADWAY FRAMING PLAN - GRIDS 24-34 (TOP)				
S-147-900R	ROADWAY FRAMING PLAN - GRIDS 34-46 & RAMP Q (BOTTOM)				
S-148-900R	ROADWAY FRAMING PLAN - GRIDS 34-46 & RAMP Q (TOP)				
S-149-900R	ROADWAY FRAMING PLAN - GRIDS 46-57 & RAMP R (BOTTOM)				
S-150-900R	ROADWAY FRAMING PLAN - GRIDS 46-57 & RAMP R (TOP)				
S-151-900R	ROADWAY FRAMING PLAN - GRIDS 57-70 (BOTTOM)				
S-152-900R	ROADWAY FRAMING PLAN - GRIDS 57-70 (TOP)				
S-153-900R	ROADWAY FRAMING PLAN - GRIDS 70-82 (BOTTOM)				
S-154-900R	ROADWAY FRAMING PLAN - GRIDS 70-82 (TOP)				
S-155-900R	ROADWAY FRAMING PLAN - GRIDS 82-94 & RAMP U (BOTTOM)				
S-156-900R	ROADWAY FRAMING PLAN - GRIDS 82-94 & RAMP U (TOP)				
S-157-900R	ROADWAY FRAMING PLAN - GRIDS 94-105 & RAMP V (BOTTOM)				
S-158-900R	ROADWAY FRAMING PLAN - GRIDS 94-105 & RAMP V (TOP)				
S-159-900R	ROADWAY FRAMING PLAN - GRIDS 105-116 (BOTTOM)				
S-160-900R	ROADWAY FRAMING PLAN - GRIDS 105-116 (TOP)				
S-161-900R	ROADWAY FRAMING PLAN - GRIDS 116-128 (BOTTOM)				
S-162-900R	ROADWAY FRAMING PLAN - GRIDS 116-128 (TOP)				
S-163-900R	ROADWAY FRAMING PLAN - GRIDS 128-133 & RAMP Y (BOTTOM)				
S-164-900R	ROADWAY FRAMING PLAN - GRIDS 128-133 & RAMP Y (TOP)				
07 - STRUCTURAL: 26					
TOTAL : 158					



DALLAS
FORT WORTH
INTERNATIONAL
AIRPORT

2330 N INTERNATIONAL PARKWAY
DFW AIRPORT, TX 75261

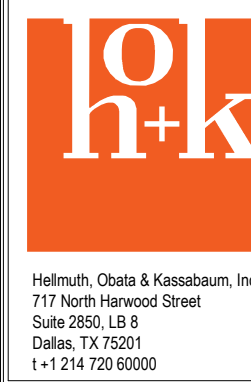

Hobbs, Clark & Koenigsmann, Inc.
777 North Meadows Street
Dallas, TX 75201
1-214-728-6000

DRAWN BY: RB
APPROVED BY: DM
ISSUE DATE: 2022-07-28

NOT FOR BID OR
CONSTRUCTION

NO.	DATE	DESCRIPTION
	2022-07-28	100% ISSUED FOR PERMIT (IFP)

PROJECT NUMBER: TFD-007

DFW TERMINAL C GARAGE AND ROADWAYS
SHEET INDEX - PHASE ROADWAYS

SHEET NUMBER

GI014-900R

PERMIT NUMBER: B22-0023

SCALE(S) AS NOTED ON THIS SHEET ARE BASED ON A FULL SIZE 30 X 42 SHEET.

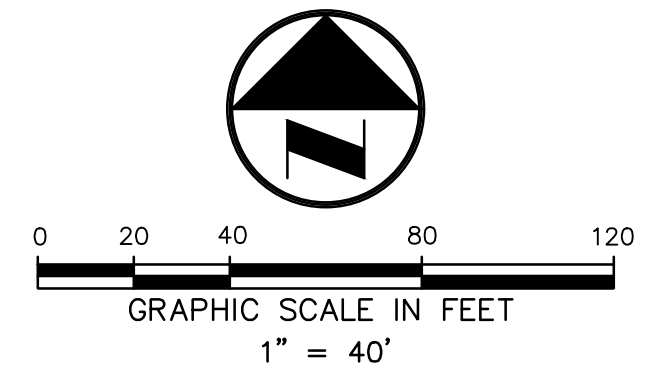

NOTES

- COORDINATES SHOWN ARE GROUND VALUES. SAID VALUES CAN BE CONVERTED TO GRID VALUES BY MULTIPLYING THE GROUND VALUES BY THE DFW AIRPORT PROJECT COMBINED SCALE FACTOR OF 0.99985318712. GRID DATA IS BASED ON THE TEXAS STATE PLANE COORDINATE SYSTEM, NORTH CENTRAL ZONE (4202), NORTH AMERICAN DATUM OF 1983 (NAD '83), 2011 ADJUSTMENT. VERTICAL DATA IS BASED ON NORTH AMERICAN DATUM OF 1988 (NAVD '88), ESTABLISHED BY A DIFFERENTIAL LEVEL LOOP USING DFW AIRPORT BRASS MONUMENT BENCHMARKS AS SHOWN IN THE TABLE. BENCHMARK 1451 WAS HELD.
- THE CONTRACTOR IS RESPONSIBLE FOR REPLACING IN KIND, AT NO ADDITIONAL COST TO THE OWNER, ANY AND ALL CONTROL POINTS DISTURBED, DAMAGED, AND / OR DESTROYED.
- ALL CONTROL POINTS, TOPOGRAPHICAL AND UTILITY INFORMATION PROVIDED BY CRIADO & ASSOCIATES, INC. FROM A SURVEY PERFORMED IN SEPTEMBER 2021.
- PRIOR TO ANY LAYOUT FOR THE PROPOSED WORK, THE CONTRACTOR MUST FIELD-VERIFY ALL CONTROL POINTS AND NOTIFY THE OWNER'S REPRESENTATIVE IF ANY DISCREPANCIES ARE FOUND.
- IT IS THE CONTRACTOR'S RESPONSIBILITY TO SET ADDITIONAL CONTROL POINTS AS MAY BE NECESSARY TO FACILITATE ACCURATE SURVEY LAYOUT.
- ALL PROJECT CONTROL AND CONSTRUCTION STAKEOUT SHALL BE PERFORMED BY THE CONTRACTOR. THE WORK MUST BE COMPLETED BY A REGISTERED PROFESSIONAL LAND SURVEYOR LICENSED BY THE STATE OF TEXAS.
- CONTRACTOR SURVEY CONTROL MUST BE VERIFIED AND APPROVED BY DFW SURVEY PRIOR TO CONSTRUCTION. NOTIFY THE OWNER OF ANY DISCREPANCIES IMMEDIATELY IF FOUND.

POINT TABLE				
POINT #	NORTHING	EASTING	ELEVATION	DESCRIPTION
1321	7013322.42	2417266.99	566.51	MDFW
1350	7013950.91	2417592.71	582.21	MDFW
1351	7013734.40	2417819.34	581.86	MDFW
1352	7013430.96	2417761.22	581.37	MDFW
1353	7013267.84	2417533.95	578.79	MDFW
1354	7013445.93	2417486.43	583.16	MDFW
1450	7013491.03	2417213.33	567.05	MDFW
1451	7013174.87	2417265.46	573.22	MDFW
1454	7013158.21	2417964.08	571.24	MDFW
1455	7013426.75	2418069.78	570.56	MDFW
1456	7013716.69	2418133.63	571.81	MDFW
1458	7014198.86	2417794.94	571.55	MDFW
1459	7014351.54	2417530.42	572.83	MDFW
1452	7012912.65	2417265.74	569.43	MDFW

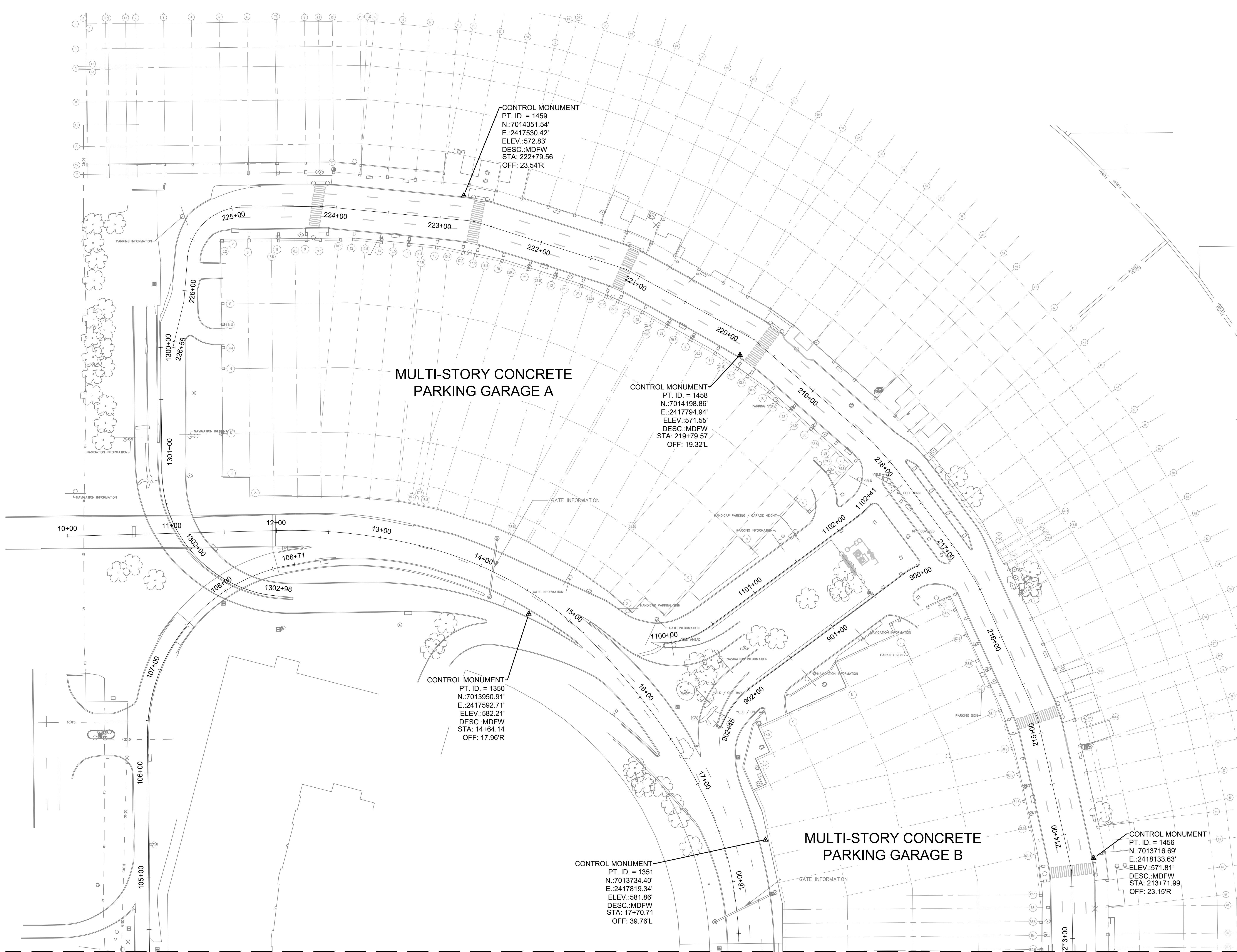

MATCHLINE - SEE SHEET V-102-900R

KEY PLAN

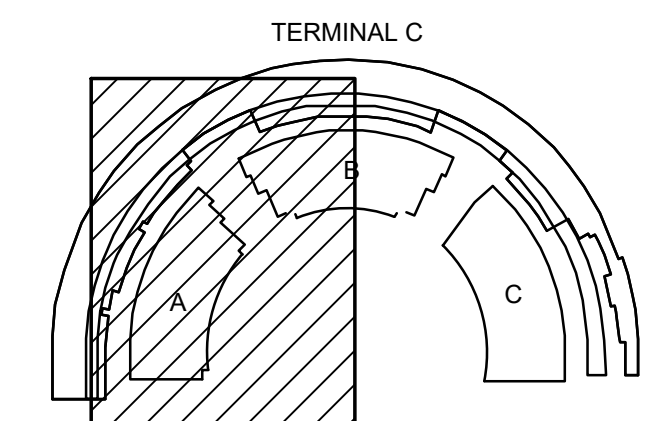

DALLAS FORT WORTH INTERNATIONAL AIRPORT
2330 N INTERNATIONAL PARKWAY
DFW AIRPORT, TX 75261

07/28/2022

CRIADO & ASSOCIATES
1100 Spring Valley Road
Suite 100
Dallas, TX 75244
+1 214 720 9900

DRAWN BY: SJP
APPROVED BY: RJC
ISSUE DATE: 2022-07-28

NOT FOR BID OR CONSTRUCTION

NO.	DATE	DESCRIPTION
2022-07-28	100% ISSUED FOR PERMIT (IFP)	

TERMINAL C GARAGE & ROADWAYS
SURVEY BENCHMARK PLAN (LOWER ROADWAY)

PROJECT NUMBER: TFD-007
PERMIT NUMBER: B22-0023

SHEET NUMBER
V-101-900R

SCALE(S) AS NOTED ON THIS SHEET ARE BASED ON A FULL SIZE 30 X 42 SHEET.

BORDER RELEASE DATE: October 16, 2021
01/20/2021 7:46:09 AM C:\Users\jrc\Documents\Projects\DFW\Terminal C\Garage\Roadways\Survey\Lower\DWG
C:\Users\jrc\Documents\Projects\DFW\Terminal C\Garage\Roadways\Survey\Lower\DWG

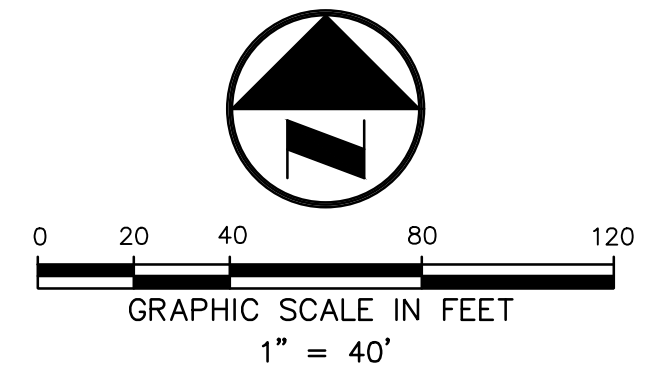

MULTI-STORY CONCRETE PARKING GARAGE B

MULTI-STORY CONCRETE PARKING GARAGE C TO BE DEMOLISHED

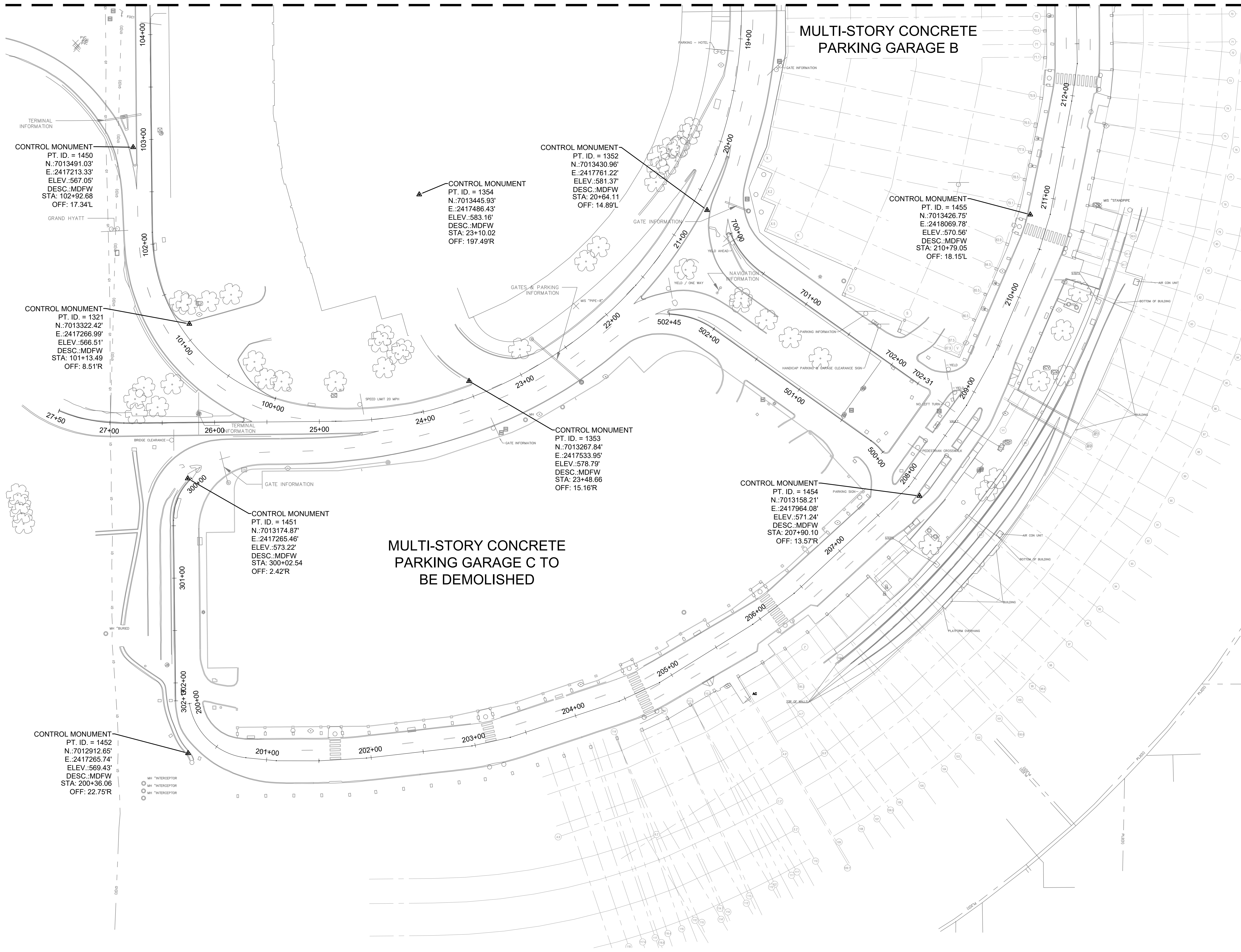

NOTES

- COORDINATES SHOWN ARE GROUND VALUES. SAID VALUES CAN BE CONVERTED TO GRID VALUES BY MULTIPLYING THE GROUND VALUES BY THE DFW AIRPORT PROJECT COMBINED SCALE FACTOR OF 0.99985318712. GRID DATA IS BASED ON THE TEXAS STATE PLANE COORDINATE SYSTEM, NORTH CENTRAL ZONE (4202), NORTH AMERICAN DATUM OF 1983 (NAD '83), 2011 ADJUSTMENT. VERTICAL DATA IS BASED ON NORTH AMERICAN DATUM OF 1988 (NAVD '88), ESTABLISHED BY A DIFFERENTIAL LEVEL LOOP USING DFW AIRPORT BRASS MONUMENT BENCHMARKS AS SHOWN IN THE TABLE. BENCHMARK 1451 WAS HELD.
- THE CONTRACTOR IS RESPONSIBLE FOR REPLACING IN KIND, AT NO ADDITIONAL COST TO THE OWNER, ANY AND ALL CONTROL POINTS DISTURBED, DAMAGED, AND / OR DESTROYED.
- ALL CONTROL POINTS, TOPOGRAPHICAL AND UTILITY INFORMATION PROVIDED BY CRIADO & ASSOCIATES, INC. FROM A SURVEY PERFORMED IN SEPTEMBER 2021.
- PRIOR TO ANY LAYOUT FOR THE PROPOSED WORK, THE CONTRACTOR MUST FIELD-VERIFY ALL CONTROL POINTS AND NOTIFY THE OWNER'S REPRESENTATIVE IF ANY DISCREPANCIES ARE FOUND.
- IT IS THE CONTRACTOR'S RESPONSIBILITY TO SET ADDITIONAL CONTROL POINTS AS MAY BE NECESSARY TO FACILITATE ACCURATE SURVEY LAYOUT.
- ALL PROJECT CONTROL AND CONSTRUCTION STAKEOUT SHALL BE PERFORMED BY THE CONTRACTOR. THE WORK MUST BE COMPLETED BY A REGISTERED PROFESSIONAL LAND SURVEYOR LICENSED BY THE STATE OF TEXAS.
- CONTRACTOR SURVEY CONTROL MUST BE VERIFIED AND APPROVED BY DFW SURVEY PRIOR TO CONSTRUCTION. NOTIFY THE OWNER OF ANY DISCREPANCIES IMMEDIATELY IF FOUND.

POINT TABLE			
POINT #	NORTHING	EASTING	DESCRIPTION
1321	7013322.42	2417266.99	566.51 MDFW
1350	7013950.91	2417592.71	582.21 MDFW
1351	7013734.40	2417819.34	581.86 MDFW
1352	7013430.96	2417761.22	581.37 MDFW
1353	7013267.84	2417533.95	578.79 MDFW
1354	7013445.93	2417486.43	583.16 MDFW
1450	7013491.03	2417213.33	567.05 MDFW
1451	7013174.87	2417265.46	573.22 MDFW
1454	7013158.21	2417964.08	571.24 MDFW
1455	7013426.75	2418069.78	570.56 MDFW
1456	7013716.69	2418133.63	571.81 MDFW
1458	7014198.86	2417794.94	571.55 MDFW
1459	7014351.54	2417530.42	572.83 MDFW
1452	7012912.65	2417265.74	569.43 MDFW

KEY PLAN

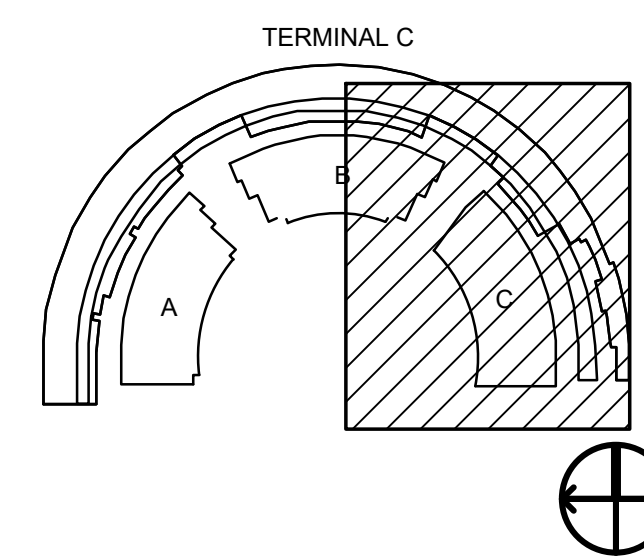

BORDER RELEASE DATE: October 16, 2021
 01/20/2021 7:45:09 AM C:\Users\jmc\Documents\DWG\DAL\DFW\Intl Airport - CTA Expansion Program\Project Files\01_CTA - Terminal C Garages and Roadways\05_CED1 - CAD\Sheets\050302-DFW-TC-V-101-900R-Survey\lower.dwg

DALLAS FORT WORTH INTERNATIONAL AIRPORT
 2330 N INTERNATIONAL PARKWAY
 DFW AIRPORT, TX 75261

h+k
CRIADO
 CRIADO & ASSOCIATES
 4100 Spring Valley Road
 Suite 1001
 Dallas, TX 75244
 +1 214 720 9000

DRAWN BY: SJP
 APPROVED BY: RIC
 ISSUE DATE: 2022-07-28

NOT FOR BID OR CONSTRUCTION

NO.	DATE	DESCRIPTION

TERMINAL C GARAGE & ROADWAYS
SURVEY BENCHMARK PLAN (LOWER ROADWAY)

PROJECT NUMBER: TFD-007

PERMIT NUMBER: B22-0023

SHEET NUMBER
V-102-900R

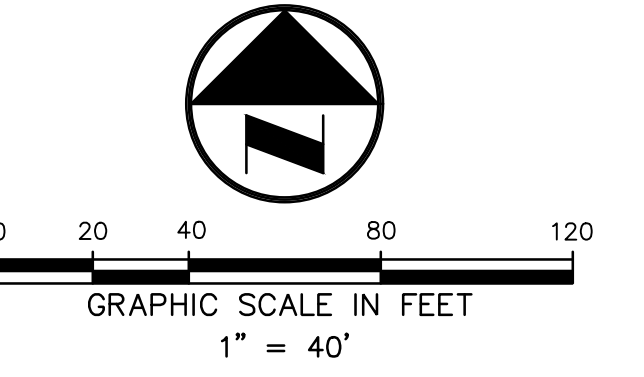

NOTES

- COORDINATES SHOWN ARE GROUND VALUES. SAID VALUES CAN BE CONVERTED TO GRID VALUES BY MULTIPLYING THE GROUND VALUES BY THE DFW AIRPORT PROJECT COMBINED SCALE FACTOR OF 0.99985318712. GRID DATA IS BASED ON THE TEXAS STATE PLANE COORDINATE SYSTEM, NORTH CENTRAL ZONE (4202), NORTH AMERICAN DATUM OF 1983 (NAD '83), 2011 ADJUSTMENT. VERTICAL DATA IS BASED ON NORTH AMERICAN DATUM OF 1988 (NAVD '88), ESTABLISHED BY A DIFFERENTIAL LEVEL LOOP USING DFW AIRPORT BRASS MONUMENT BENCHMARKS AS SHOWN IN THE TABLE. BENCHMARK 1451 WAS HELD.
- THE CONTRACTOR IS RESPONSIBLE FOR REPLACING IN KIND, AT NO ADDITIONAL COST TO THE OWNER, ANY AND ALL CONTROL POINTS DISTURBED, DAMAGED, AND / OR DESTROYED.
- ALL CONTROL POINTS, TOPOGRAPHICAL AND UTILITY INFORMATION PROVIDED BY CRIADO & ASSOCIATES, INC. FROM A SURVEY PERFORMED IN SEPTEMBER 2021.
- PRIOR TO ANY LAYOUT FOR THE PROPOSED WORK, THE CONTRACTOR MUST FIELD-VERIFY ALL CONTROL POINTS AND NOTIFY THE OWNER'S REPRESENTATIVE IF ANY DISCREPANCIES ARE FOUND.
- IT IS THE CONTRACTOR'S RESPONSIBILITY TO SET ADDITIONAL CONTROL POINTS AS MAY BE NECESSARY TO FACILITATE ACCURATE SURVEY LAYOUT.
- ALL PROJECT CONTROL AND CONSTRUCTION STAKEOUT SHALL BE PERFORMED BY THE CONTRACTOR. THE WORK MUST BE COMPLETED BY A REGISTERED PROFESSIONAL LAND SURVEYOR LICENSED BY THE STATE OF TEXAS.
- CONTRACTOR SURVEY CONTROL MUST BE VERIFIED AND APPROVED BY DFW SURVEY PRIOR TO CONSTRUCTION. NOTIFY THE OWNER OF ANY DISCREPANCIES IMMEDIATELY IF FOUND.

POINT TABLE				
POINT #	NORTHING	EASTING	ELEVATION	DESCRIPTION
1315	7013908.30	2418038.72	591.11	MDFW
1316	7013703.11	2418084.36	590.49	MDFW
1317	7013558.90	2418086.87	590.33	MDFW
1451	7013174.87	2417265.46	573.22	MDFW
1452	7012912.65	2417265.74	569.43	MDFW

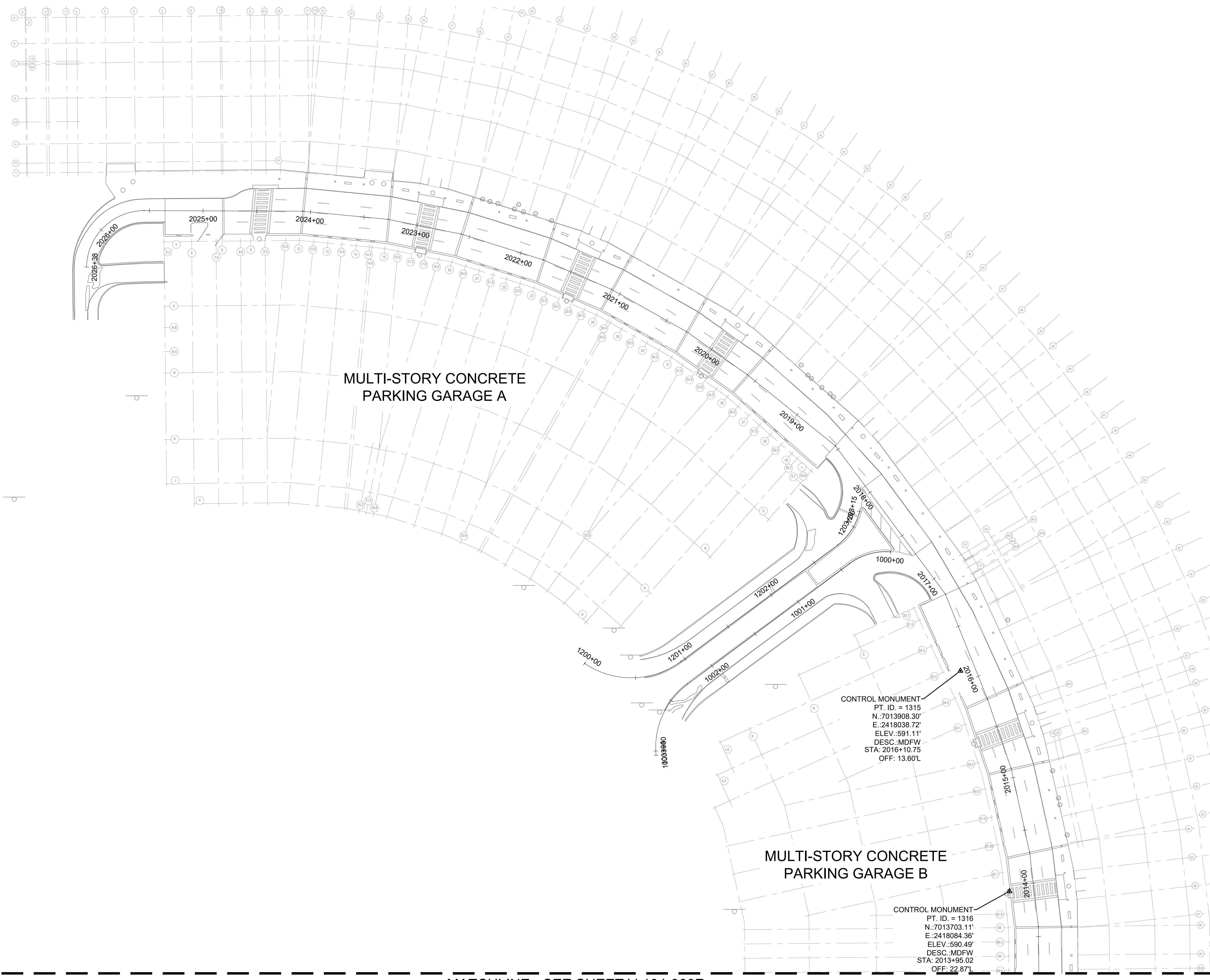

MATCHLINE - SEE SHEET V-104-900R

KEY PLAN

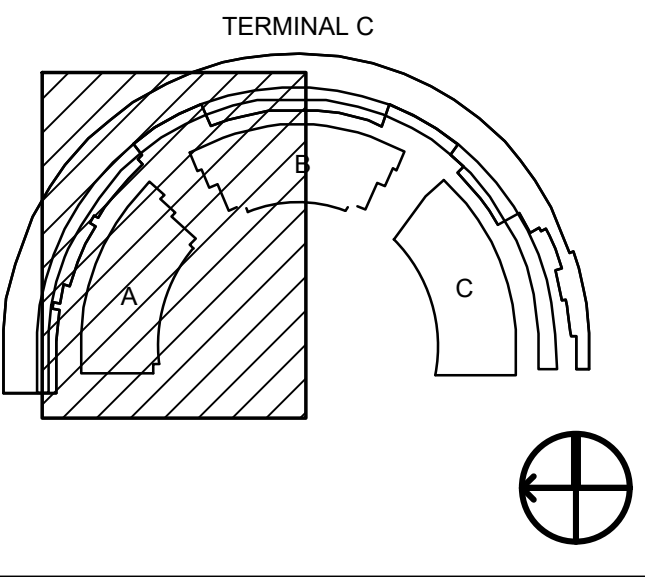

BORDER RELEASE DATE: October 16, 2021
 01/20/2021 7:46:09 AM C:\Users\jgarcia\OneDrive\Documents\DWG\Drawings\2021\104-900R-Survey\Upper.dwg

DALLAS FORT WORTH INTERNATIONAL AIRPORT
 2330 N INTERNATIONAL PARKWAY
 DFW AIRPORT, TX 75261

07/28/2022

h+k
CRIADO
 CRIADO & ASSOCIATES
 4100 Spring Valley Road
 Suite 100
 Dallas, TX 75244
 1+1214 720 9000 1+1972 382 9992

DRAWN BY: SJP
 APPROVED BY: RIC
 ISSUE DATE: 2022-07-28

NOT FOR BID OR CONSTRUCTION

NO.	DATE	DESCRIPTION

TERMINAL C GARAGE & ROADWAYS
SURVEY BENCHMARK PLAN (UPPER ROADWAY)

PROJECT NUMBER: TFD-007

PERMIT NUMBER: B22-0023

SHEET NUMBER
V-103-900R

SCALE(S) AS NOTED ON THIS SHEET ARE BASED ON A FULL SIZE 30 X 42 SHEET.

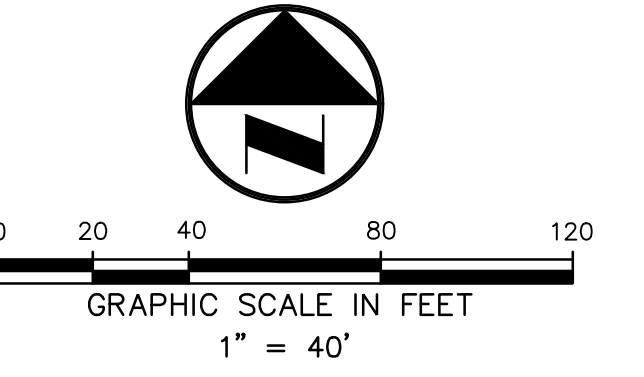

NOTES

1. COORDINATES SHOWN ARE GROUND VALUES. SAID VALUES CAN BE CONVERTED TO GRID VALUES BY MULTIPLYING THE GROUND VALUES BY THE DFW AIRPORT PROJECT COMBINED SCALE FACTOR OF 0.99985318712. GRID DATA IS BASED ON THE TEXAS STATE PLANE COORDINATE SYSTEM, NORTH CENTRAL ZONE (4202), NORTH AMERICAN DATUM OF 1983 (NAD '83), 2011 ADJUSTMENT. VERTICAL DATA IS BASED ON NORTH AMERICAN DATUM OF 1988 (NAVD '88), ESTABLISHED BY A DIFFERENTIAL LEVEL LOOP USING DFW AIRPORT BRASS MONUMENT BENCHMARKS AS SHOWN IN THE TABLE. BENCHMARK 1451 WAS HELD.
2. THE CONTRACTOR IS RESPONSIBLE FOR REPLACING IN KIND, AT NO ADDITIONAL COST TO THE OWNER, ANY AND ALL CONTROL POINTS DISTURBED, DAMAGED, AND / OR DESTROYED.
3. ALL CONTROL POINTS, TOPOGRAPHICAL AND UTILITY INFORMATION PROVIDED BY CRIADO & ASSOCIATES, INC. FROM A SURVEY PERFORMED IN SEPTEMBER 2021.
4. PRIOR TO ANY LAYOUT FOR THE PROPOSED WORK, THE CONTRACTOR MUST FIELD-VERIFY ALL CONTROL POINTS AND NOTIFY THE OWNER'S REPRESENTATIVE IF ANY DISCREPANCIES ARE FOUND.
5. IT IS THE CONTRACTOR'S RESPONSIBILITY TO SET ADDITIONAL CONTROL POINTS AS MAY BE NECESSARY TO FACILITATE ACCURATE SURVEY LAYOUT.
6. ALL PROJECT CONTROL AND CONSTRUCTION STAKEOUT SHALL BE PERFORMED BY THE CONTRACTOR. THE WORK MUST BE COMPLETED BY A REGISTERED PROFESSIONAL LAND SURVEYOR LICENSED BY THE STATE OF TEXAS.
7. CONTRACTOR SURVEY CONTROL MUST BE VERIFIED AND APPROVED BY DFW SURVEY PRIOR TO CONSTRUCTION. NOTIFY THE OWNER OF ANY DISCREPANCIES IMMEDIATELY IF FOUND.

POINT TABLE				
POINT #	NORTHING	EASTING	ELEVATION	DESCRIPTION
1315	7013908.30	2418038.72	591.11	MDFW
1316	7013703.11	2418084.36	590.49	MDFW
1317	7013558.90	2418086.87	590.33	MDFW
1451	7013174.87	2417265.46	573.22	MDFW
1452	7012912.65	2417265.74	569.43	MDFW

KEY PLAN

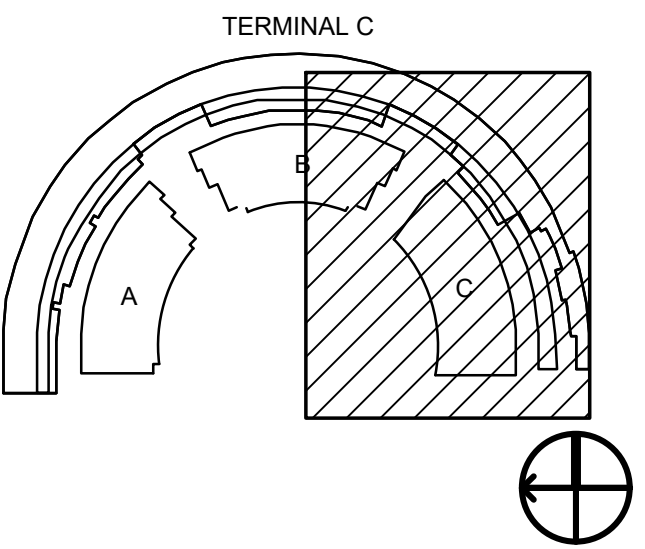

MULTI-STORY CONCRETE PARKING GARAGE B

CONTROL MONUMENT
PT. ID. = 1317
N.:7013558.90'
E.:2418086.87'
ELEV.:590.33'
DESC.:MDFW
STA: 2012+45.67
OFF: 22.11'L

CONTROL MONUMENT
PT. ID. = 1451
N.:7013174.87'
E.:2417265.46'
ELEV.:573.22'
DESC.:MDFW
STA: 300+02.54
OFF: 2.42'R

GARAGE C ENTRANCE
(LOWER LEVEL) BASELINE

CONTROL MONUMENT
PT. ID. = 1452
N.:7012912.65'
E.:2417265.74'
ELEV.:569.43'
DESC.:MDFW
STA: 2000+56.21
OFF: 2.57'R

BORDER RELEASE DATE: October 16, 2021
01/20/2021 7:46:09 AM C:\Users\jgarcia\OneDrive\Documents\HOK\DAL\DFW Int'l Airport - CTA Expansion Program\Project Files\01_CTA - Terminal C Garages and Roadways\03-DFW-TC-V-103-900R-Survey\Upper.dwg



2330 N INTERNATIONAL PARKWAY
DFW AIRPORT, TX 75261

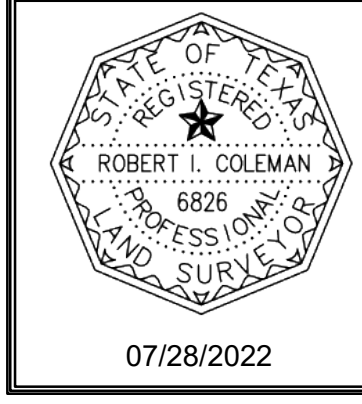

DRAWN BY: SJP
APPROVED BY: RIC
ISSUE DATE: 2022-07-28
NOT FOR BID OR CONSTRUCTION

NO.	DATE	DESCRIPTION

TERMINAL C GARAGE & ROADWAYS
SURVEY BENCHMARK PLAN (UPPER ROADWAY)

PROJECT NUMBER: TFD-007

PERMIT NUMBER: B22-0023

SHEET NUMBER
V-104-900R

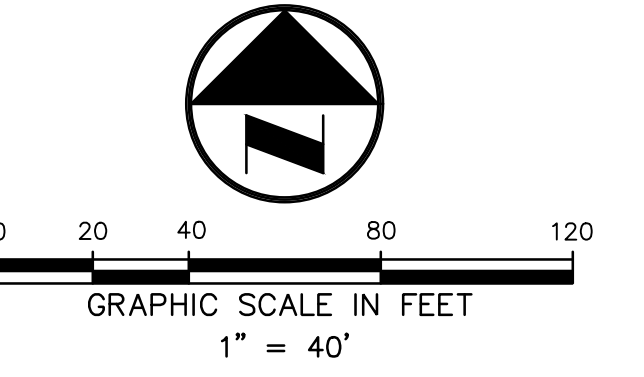

EXISTING LEGEND

- CRIADO CONTROL POINT
- IRON ROD FOUND
- BOLLARD
- GAS METER
- TRAFFIC SIGNAL LIGHT
- POLE
- TRAFFIC SIGNAL PULL BOX
- TRAFFIC SIGNAL CONTROL BOX
- TELECOM SERVICE BOX
- TELECOM PEDESTAL
- TELECOM MANHOLE
- CATV PEDESTAL
- CATV JUNCTION BOX
- CATV APPURTENANCE
- LIGHT POLE
- CATHODIC PROTECTION
- FLAG POLE
- GENERIC MANHOLE
- POWER POLE
- GUYWIRE
- ELECTRIC MANHOLE
- ELECTRIC PULL BOX
- ELECTRIC METER
- ELECTRIC BOX
- ELECTRIC RISER
- GROUND LIGHT
- SIGN
- GAS PUMP
- FUEL TANK VENT
- TREE
- BUSH
- WASTE WATER CLEANOUT
- WASTE WATER MANHOLE
- STORM DRAIN MANHOLE
- WATER VALVE
- IRRIGATION CONTROL VALVE
- SPRINKLER HEAD
- SPIGOT
- FIRE HYDRANT
- WATER METER
- OVERHEAD UTILITY
- OVERHEAD ELECTRIC

DEMOLITION LEGEND

- FULL-DEPTH CONCRETE PAVEMENT REMOVAL
- CONCRETE SIDEWALK REMOVAL
- CONCRETE CURB & GUTTER REMOVAL
- WALL REMOVAL
- ITEM TO BE REMOVED

GENERAL NOTES

1. SEE LOWER ROADWAY PHASING SEQUENCING NOTES ON SHEET CT100-900R FOR ADDITIONAL DETAILS.
2. SEE PAVEMENT REPAIR PLAN ON SHEETS CP109-900R & CP110-900R FOR ADDITIONAL DETAILS.
3. PAVEMENT REPAIR LOCATIONS ARE APPROXIMATE. PRIOR TO START OF WORK, CONTRACTOR IS TO PERFORM INSPECTION TO CONFIRM LIMITS OF PAVEMENT REPLACEMENT. IF THE LIMITS OF PAVEMENT DETERIORATION EXCEED THE ESTIMATED QUANTITY SHOWN IN THE DRAWINGS, THE CONTRACTOR IS TO CONTACT OWNER'S REPRESENTATIVE. SEE SHEETS CP-100-900R AND CP-110-900R FOR PATCH SIZES.
4. EXISTING BRIDGE FOOTINGS, COLUMNS, RETAINING WALLS AND OVERHEAD ELEMENTS ARE TO REMAIN. CONTRACTOR TO USE THE UTMOST CARE AROUND THEM AND NOT UNDERMINE ANY PART. IF THE CONTRACTOR HITS/DAMAGES ANY BRIDGE PARTS, THEY NEED TO CONTACT THE OWNER'S REPRESENTATIVE IMMEDIATELY. ANY REPAIRS AS A RESULT OF CONTRACTOR ACTIVITY IS THE RESPONSIBILITY OF THE CONTRACTOR.
5. EXISTING CURBS AND SIDE WALKS TO REMAIN UNLESS SPECIFICALLY SHOWN TO BE REMOVED. CONTRACTOR TO USE THE UTMOST CARE AROUND THEM AND NOT UNDERMINE ANY PART. IF THE CONTRACTOR HITS/DAMAGES ANY BRIDGE PARTS, THEY NEED TO CONTACT THE OWNER'S REPRESENTATIVE IMMEDIATELY. ANY REPAIRS AS A RESULT OF CONTRACTOR ACTIVITY IS THE RESPONSIBILITY OF THE CONTRACTOR.
6. MAXIMUM CLEAR HEIGHT OF LOWER LEVEL ROADWAY IS 14'-0" IN DRIVE LANES.

KEY PLAN

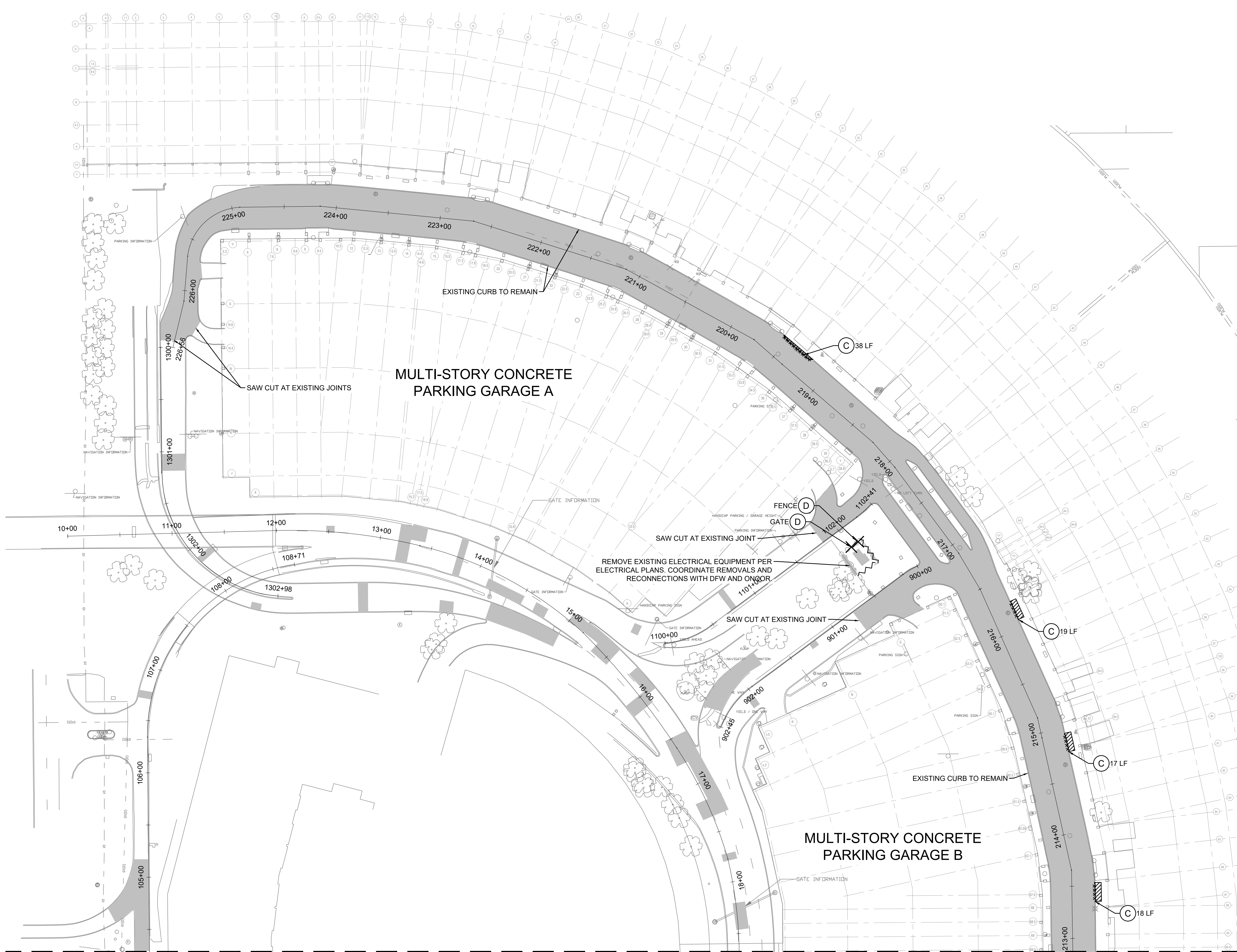
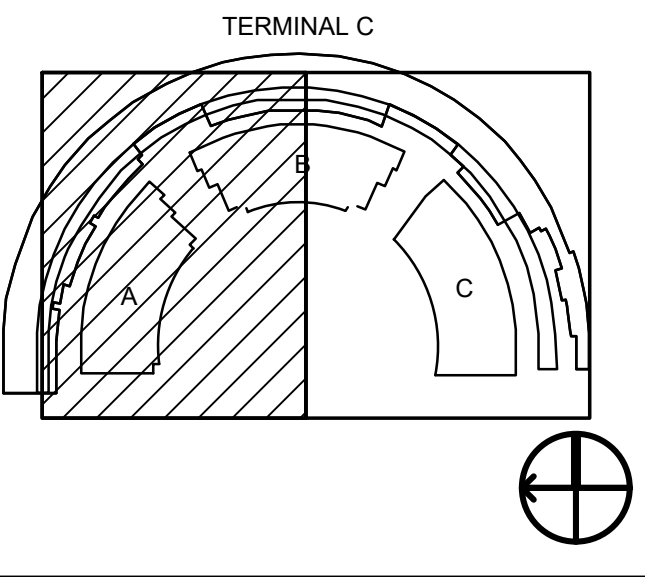

MATCHLINE - SEE SHEET CD102-900R

BORDER RELEASE DATE: October 16, 2021
 01/20/2021 14:50:09
 C:\Users\mcc203\OneDrive\Documents\CD101-900R\CD101-900R\RoadDemo.dwg

DALLAS
FORT WORTH
INTERNATIONAL
AIRPORT

2330 N INTERNATIONAL PARKWAY
DFW AIRPORT, TX 75261



Primera

Primera Engineers, Ltd.
300 West 7th
Suite 211
Dallas, TX 75201
+1 214 720 8000

DRAWN BY: SJP
APPROVED BY: JMA
ISSUE DATE: 2022-07-28

NOT FOR BID OR CONSTRUCTION

NO.	DATE	DESCRIPTION
0001	01-20-21	30% DESIGN
0002	01-06-22	30% DESIGN
0003	05-01-22	100% DESIGN
0004	07-28-22	100% REVISED FOR PERMIT (RFP)

TERMINAL C GARAGE & ROADWAYS

DEMOLITION PLAN (LOWER LEVEL)

PROJECT NUMBER: TFD-007

PERMIT NUMBER: B22-0023

SHEET NUMBER

CD101-900R

SCALE(S) AS NOTED ON THIS SHEET ARE BASED ON A FULL SIZE 30 X 42 SHEET.

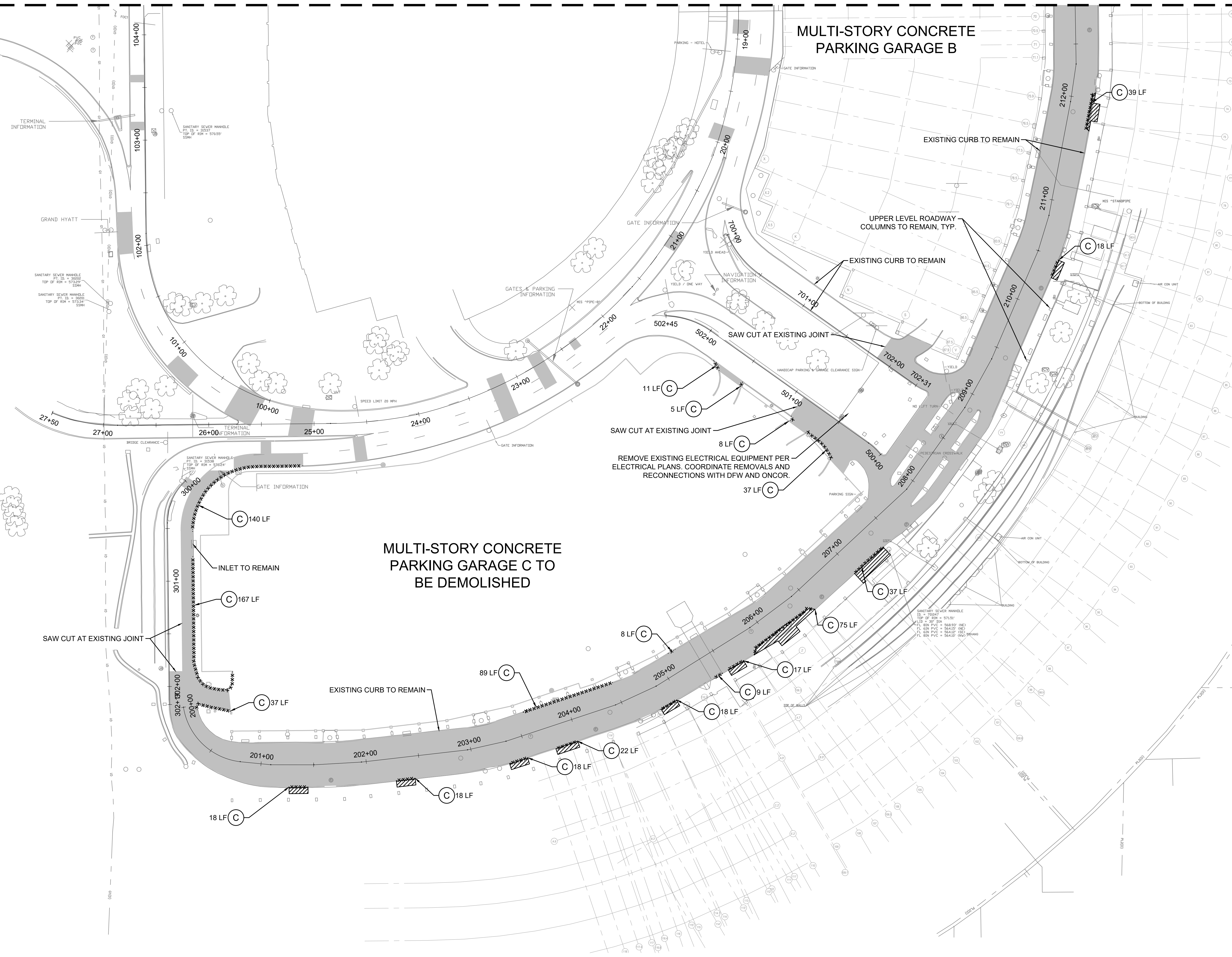
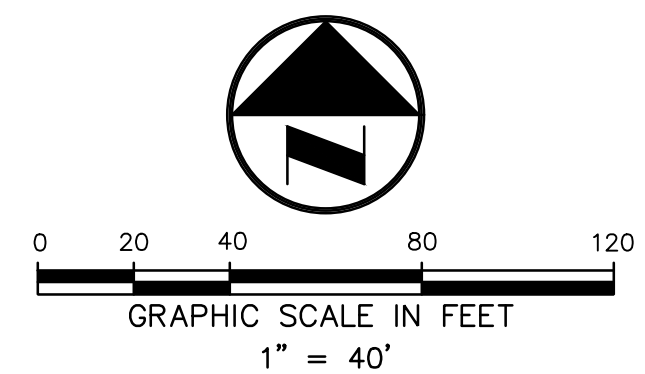

EXISTING LEGEND

- CRIADO CONTROL POINT
- IRON ROD FOUND
- BOLLARD
- GAS METER
- TRAFFIC SIGNAL LIGHT POLE
- TRAFFIC SIGNAL PULL BOX
- TRAFFIC SIGNAL CONTROL BOX
- TELECOM SERVICE BOX
- TELECOM PEDESTAL
- CATV PEDESTAL
- CATV JUNCTION BOX
- CATV APPURTENANCE
- CATHODIC PROTECTION LIGHT POLE
- FLAG POLE
- GENERIC MANHOLE
- POWER POLE
- GUYWIRE
- ELECTRIC MANHOLE
- ELECTRIC PULL BOX
- ELECTRIC METER
- ELECTRIC BOX
- ELECTRIC RISER
- GROUND LIGHT SIGN
- GAS PUMP
- FUEL TANK VENT
- TREE
- BUSH
- WASTE WATER CLEANOUT
- WASTE WATER MANHOLE
- STORM DRAIN MANHOLE
- WATER VALVE
- IRRIGATION CONTROL VALVE
- SPRINKLER HEAD
- SPIGOT
- FIRE HYDRANT
- WATER METER
- OVERHEAD UTILITY
- OVERHEAD ELECTRIC

DEMOLITION LEGEND

- FULL-DEPTH CONCRETE PAVEMENT REMOVAL
- ▨ CONCRETE SIDEWALK REMOVAL
- xxx• CONCRETE CURB & GUTTER REMOVAL
- ~ WALL REMOVAL
- ⊗ ITEM TO BE REMOVED

GENERAL NOTES

1. SEE LOWER ROADWAY PHASING SEQUENCING NOTES ON SHEET CT100-900R FOR ADDITIONAL DETAILS.
2. SEE PAVEMENT REPAIR PLAN ON SHEETS CP109-900R & CP110-900R FOR ADDITIONAL DETAILS.
3. PAVEMENT REPAIR LOCATIONS ARE APPROXIMATE. PRIOR TO START OF WORK, CONTRACTOR IS TO PERFORM INSPECTION TO CONFIRM LIMITS OF PAVEMENT REPLACEMENT. IF THE LIMITS OF PAVEMENT DETERIORATION EXCEED THE ESTIMATED QUANTITY SHOWN IN THE DRAWINGS, THE CONTRACTOR IS TO CONTACT OWNER'S REPRESENTATIVE. SEE SHEETS CP-100-900R AND CP-110-900R FOR PATCH SIZES.
4. EXISTING BRIDGE FOOTINGS, COLUMNS, RETAINING WALLS AND OVERHEAD ELEMENTS ARE TO REMAIN. CONTRACTOR TO USE THE UTMOST CARE AROUND THEM AND NOT UNDERMINE ANY PART. IF THE CONTRACTOR HITS/DAMAGES ANY BRIDGE PARTS, THEY NEED TO CONTACT THE OWNER'S REPRESENTATIVE IMMEDIATELY. ANY REPAIRS AS A RESULT OF CONTRACTOR ACTIVITY IS THE RESPONSIBILITY OF THE CONTRACTOR.
5. EXISTING CURBS AND SIDE WALKS TO REMAIN UNLESS SPECIFICALLY SHOWN TO BE REMOVED. CONTRACTOR TO USE THE UTMOST CARE AROUND THEM AND NOT UNDERMINE ANY PART. IF THE CONTRACTOR HITS/DAMAGES ANY BRIDGE PARTS, THEY NEED TO CONTACT THE OWNER'S REPRESENTATIVE IMMEDIATELY. ANY REPAIRS AS A RESULT OF CONTRACTOR ACTIVITY IS THE RESPONSIBILITY OF THE CONTRACTOR.
6. MAXIMUM CLEAR HEIGHT OF LOWER LEVEL ROADWAY IS 14'-0" IN DRIVE LANES.

KEY PLAN

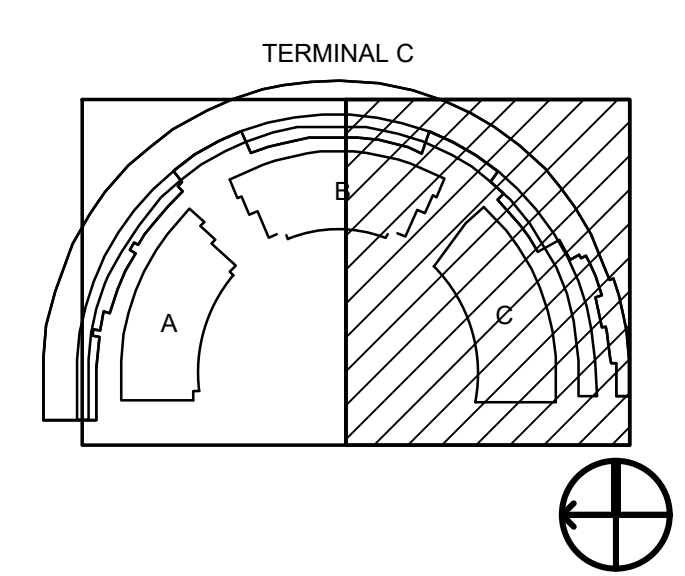

BORDER RELEASE DATE: October 16, 2021
 01/20/2021 10:50:09 AM
 C:\Users\jrc2\OneDrive\Documents\CD102-900R\CD102-900R.dwg



DALLAS FORT WORTH INTERNATIONAL AIRPORT
 2330 N INTERNATIONAL PARKWAY
 DFW AIRPORT, TX 75261



h+k **Primera**
 Herrera, Obeso & Kozminski, Inc.
 777 South Meadows Drive
 Suite 2000, LB #
 Dallas, TX 75201
 (+1) 214 720 8000

DRAWN BY: SJP
 APPROVED BY: JMA
 ISSUE DATE: 2022-07-28
NOT FOR BID OR CONSTRUCTION

NO.	DATE	DESCRIPTION
0001	01-20-21	30% DESIGN
0002	01-06-21	50% DESIGN
0003	05-01-21	100% DESIGN
0004	07-28-22	100% REVISED FOR PERMIT (RFP)

TERMINAL C GARAGE & ROADWAYS
DEMOLITION PLAN (LOWER LEVEL)
 PROJECT NUMBER: TFD-007
 PERMIT NUMBER: B22-0023

SHEET NUMBER
CD102-900R

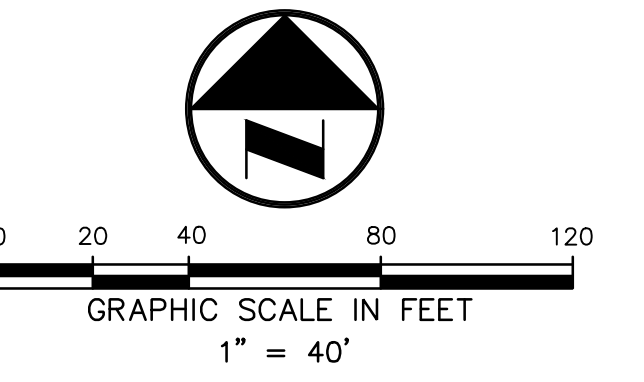

EXISTING LEGEND

- CRIADO CONTROL POINT
- IRON ROD FOUND
- BOLLARD
- GAS METER
- TRAFFIC SIGNAL LIGHT POLE
- TRAFFIC SIGNAL PULL BOX
- TRAFFIC SIGNAL CONTROL BOX
- TELECOM SERVICE BOX
- TELECOM PEDESTAL
- TELECOM MANHOLE
- CATV PEDESTAL
- CATV JUNCTION BOX
- CATV APPURTENANCE
- LIGHT POLE
- CATHODIC PROTECTION
- FLAG POLE
- GENERIC MANHOLE
- POWER POLE
- GUYWIRE
- ELECTRIC MANHOLE
- ELECTRIC PULL BOX
- ELECTRIC METER
- ELECTRIC BOX
- ELECTRIC RISER
- GROUND LIGHT SIGN
- GAS PUMP
- FUEL TANK VENT
- TREE
- BUSH
- WASTE WATER CLEANOUT
- WASTE WATER MANHOLE
- STORM DRAIN MANHOLE
- WATER VALVE
- IRRIGATION CONTROL VALVE
- SPRINKLER HEAD
- SPIGOT
- FIRE HYDRANT
- WATER METER
- OVERHEAD UTILITY
- OVERHEAD ELECTRIC

DEMOLITION LEGEND

- FULL-DEPTH CONCRETE PAVEMENT REMOVAL
- FULL-DEPTH CONCRETE PAVEMENT REMOVAL (PROPOSED STORM SEWER LAYOUT. SEE SHEET CU1-0-0108)
- FULL-DEPTH CONCRETE PAVEMENT REMOVAL (ALTERNATE STORM SEWER LAYOUT. SEE SHEET CU1-0-0108)
- ASPHALT MILLING (SEE PAVING PLANS FOR OVERLAY INFORMATION)
- CONCRETE SIDEWALK REMOVAL
- CONCRETE CURB & GUTTER REMOVAL
- WALL REMOVAL
- ITEM TO BE REMOVED

NOTES:

1. SEE UPPER ROADWAY PHASING SEQUENCING NOTES ON SHEET CT100-900R FOR ADDITIONAL DETAIL.
2. EXISTING BRIDGE FOOTINGS, COLUMNS, RETAINING WALLS AND OVERHEAD ELEMENTS ARE TO REMAIN. CONTRACTOR TO USE THE UTMOST CARE AROUND THEM AND NOT UNDERMINE ANY PART. IF THE CONTRACTOR HITS/DAMAGES ANY BRIDGE PARTS, THEY NEED TO CONTACT THE OWNER'S REPRESENTATIVE IMMEDIATELY. ANY REPAIRS AS A RESULT OF CONTRACTOR ACTIVITY IS THE RESPONSIBILITY OF THE CONTRACTOR.
3. EXISTING CURBS AND SIDE WALKS TO REMAIN UNLESS SPECIFICALLY SHOWN TO BE REMOVED. CONTRACTOR TO USE THE UTMOST CARE AROUND THEM AND NOT UNDERMINE ANY PART. IF THE CONTRACTOR HITS/DAMAGES ANY BRIDGE PARTS, THEY NEED TO CONTACT THE OWNER'S REPRESENTATIVE IMMEDIATELY. ANY REPAIRS AS A RESULT OF CONTRACTOR ACTIVITY IS THE RESPONSIBILITY OF THE CONTRACTOR.

KEY PLAN

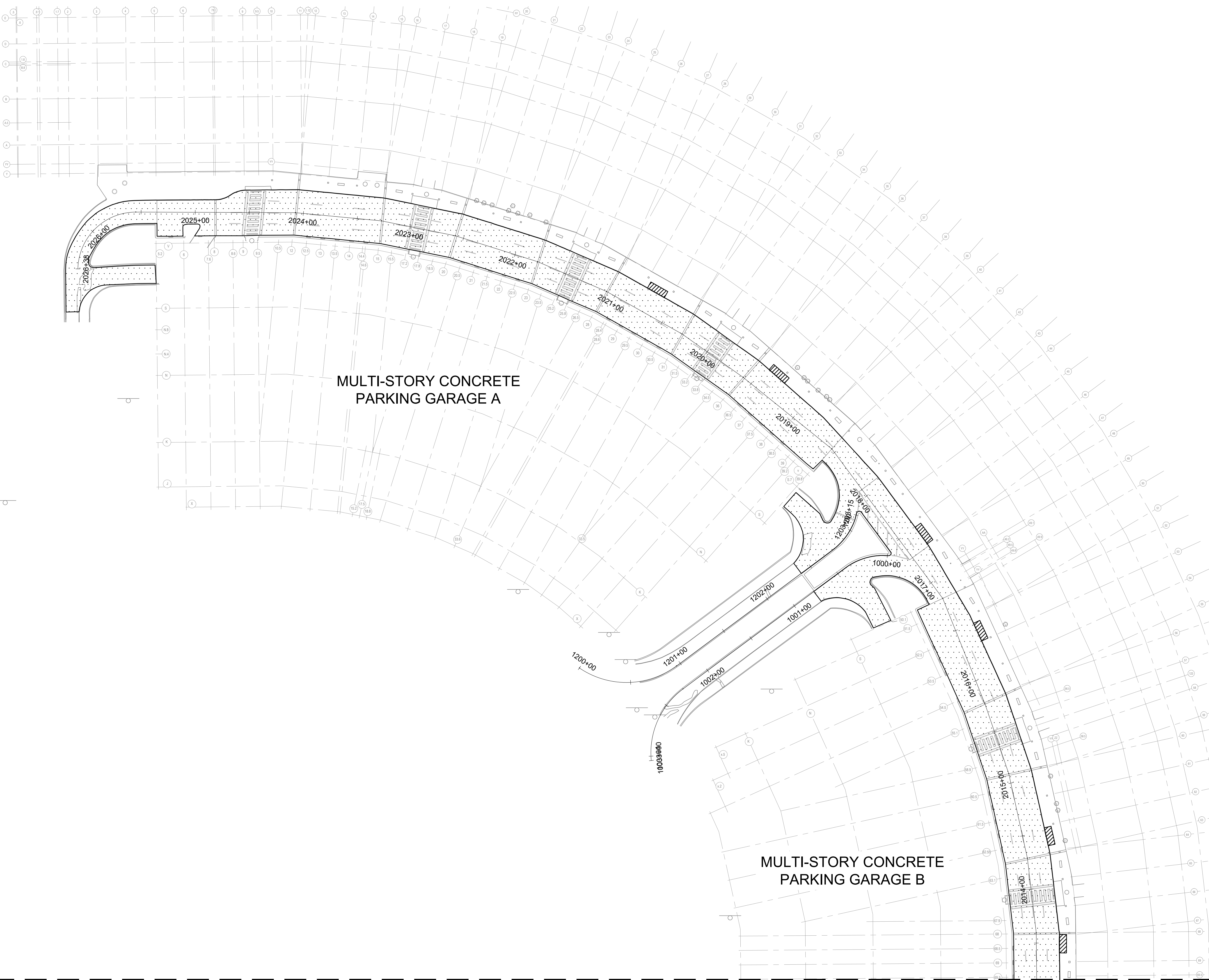
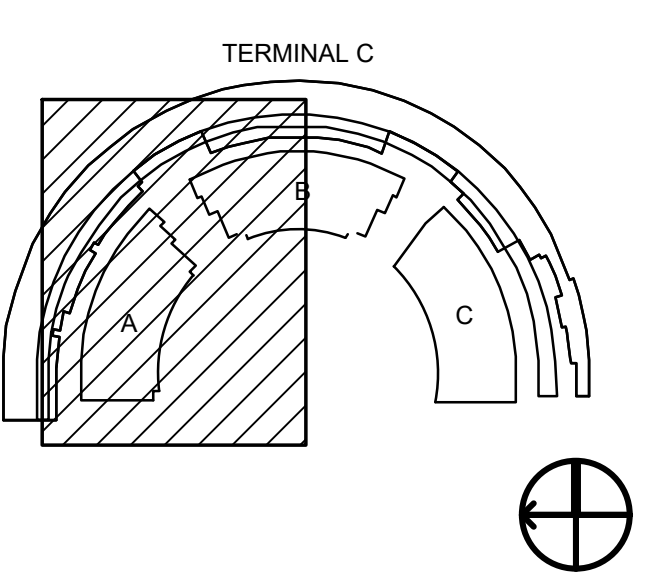

MATCHLINE - SEE SHEET CD104-900R

BORDER RELEASE DATE: October 16, 2021
 01/20/2021 10:59:09 AM C:\Users\mrc2233\OneDrive\Documents\CD103-900R-Upper.dwg
 C:\Users\mrc2233\OneDrive\Documents\CD103-900R-Upper.dwg

DALLAS
FORT WORTH
INTERNATIONAL
AIRPORT

2330 N INTERNATIONAL PARKWAY
DFW AIRPORT, TX 75261

JOSEPH MICHAEL AVRAM
12736
12736
12736

Primera
Primera Engineers, LLC
300 West 7th
Suite 211
Dallas, TX 75201
+1 214 720 8000

DRAWN BY: SJP
 APPROVED BY: JMA
 ISSUE DATE: 2022-07-28
NOT FOR BID OR CONSTRUCTION

NO.	DATE	DESCRIPTION
1	2022-09-01	100% DESIGN
2	2022-07-28	100% DESIGN FOR PERMIT (DPP)

TERMINAL C GARAGE & ROADWAYS
DEMOLITION PLAN (UPPER ROADWAY)

PROJECT NUMBER: TFD-007

PERMIT NUMBER: B22-0023

SHEET NUMBER
CD103-900R

SCALE(S) AS NOTED ON THIS SHEET ARE BASED ON A FULL SIZE 30 X 42 SHEET.

MATCHLINE - SEE SHEET CD103-900R

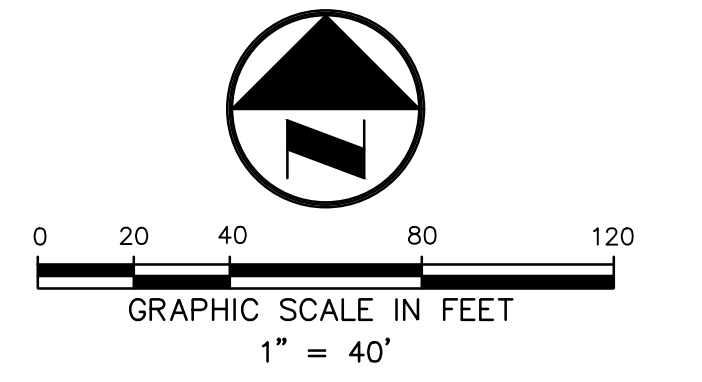

MULTI-STORY CONCRETE
PARKING GARAGE B

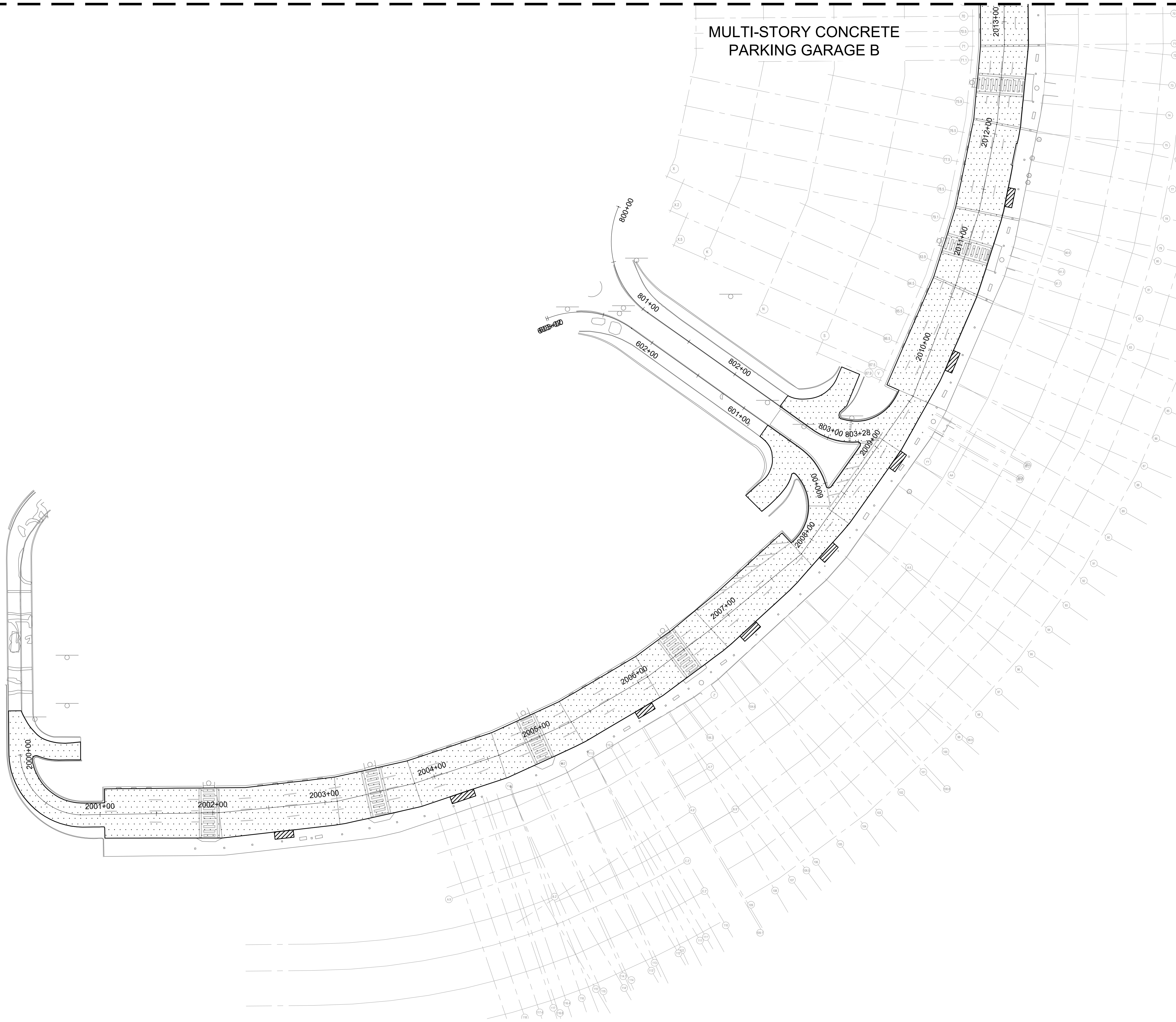

EXISTING LEGEND

- CRIADO CONTROL POINT
- IRON ROD FOUND
- BOLLARD
- GAS METER
- TRAFFIC SIGNAL LIGHT POLE
- TRAFFIC SIGNAL PULL BOX
- TRAFFIC SIGNAL CONTROL BOX
- TELECOM SERVICE BOX
- TELECOM PEDESTAL
- CATV PEDESTAL
- CATV JUNCTION BOX
- CATV APPURTENANCE
- LIGHT POLE
- CATHODIC PROTECTION
- FLAG POLE
- GENERIC MANHOLE
- POWER MANHOLE
- GUYWIRE
- ELECTRIC MANHOLE
- ELECTRIC PULL BOX
- ELECTRIC METER
- ELECTRIC BOX
- ELECTRIC RISER
- GROUND LIGHT SIGN
- GAS PUMP
- FUEL TANK VENT
- TREE
- BUSH
- WASTE WATER CLEANOUT
- WASTE WATER MANHOLE
- STORM DRAIN MANHOLE
- WATER VALVE
- IRRIGATION CONTROL VALVE
- SPRINKLER HEAD
- SPIGOT
- FIRE HYDRANT
- WATER METER
- OVERHEAD UTILITY
- OVERHEAD ELECTRIC

DEMOLITION LEGEND

- FULL-DEPTH CONCRETE PAVEMENT REMOVAL
- ▨ FULL-DEPTH CONCRETE PAVEMENT REMOVAL (PROPOSED STORM SEWER LAYOUT. SEE SHEET CU1-0-0108)
- ▧ FULL-DEPTH CONCRETE PAVEMENT REMOVAL (ALTERNATE STORM SEWER LAYOUT. SEE SHEET CU1-0-0108)
- ▩ ASPHALT MILLING (SEE PAVING PLANS FOR OVERLAY INFORMATION)
- ▨ CONCRETE SIDEWALK REMOVAL
- xxx• (C) CONCRETE CURB & GUTTER REMOVAL
- ~ WALL REMOVAL
- ⊗ (D) ITEM TO BE REMOVED

NOTES:

1. SEE UPPER ROADWAY PHASING SEQUENCING NOTES ON SHEET CT100-900R FOR ADDITIONAL DETAIL.
2. EXISTING BRIDGE FOOTINGS, COLUMNS, RETAINING WALLS AND OVERHEAD ELEMENTS ARE TO REMAIN. CONTRACTOR TO USE THE UTMOST CARE AROUND THEM AND NOT UNDERMINE ANY PART. IF THE CONTRACTOR HITS/DAMAGES ANY BRIDGE PARTS, THEY NEED TO CONTACT THE OWNER'S REPRESENTATIVE IMMEDIATELY. ANY REPAIRS AS A RESULT OF CONTRACTOR ACTIVITY IS THE RESPONSIBILITY OF THE CONTRACTOR.
3. EXISTING CURBS AND SIDE WALKS TO REMAIN UNLESS SPECIFICALLY SHOWN TO BE REMOVED. CONTRACTOR TO USE THE UTMOST CARE AROUND THEM AND NOT UNDERMINE ANY PART. IF THE CONTRACTOR HITS/DAMAGES ANY BRIDGE PARTS, THEY NEED TO CONTACT THE OWNER'S REPRESENTATIVE IMMEDIATELY. ANY REPAIRS AS A RESULT OF CONTRACTOR ACTIVITY IS THE RESPONSIBILITY OF THE CONTRACTOR.

KEY PLAN

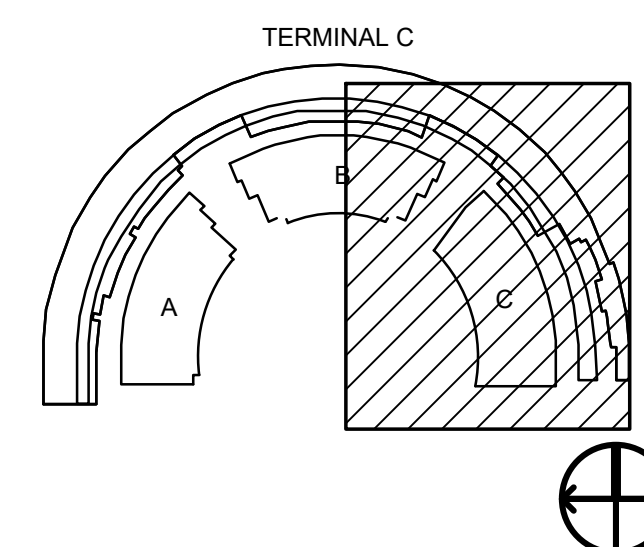

BORDER RELEASE DATE: October 16, 2021
01/20/2021 10:50:09 AM C:\Users\hrc2303\OneDrive\Documents\CD104-900R\CD104-900R-Upper.dwg



DALLAS
FORT WORTH
INTERNATIONAL
AIRPORT

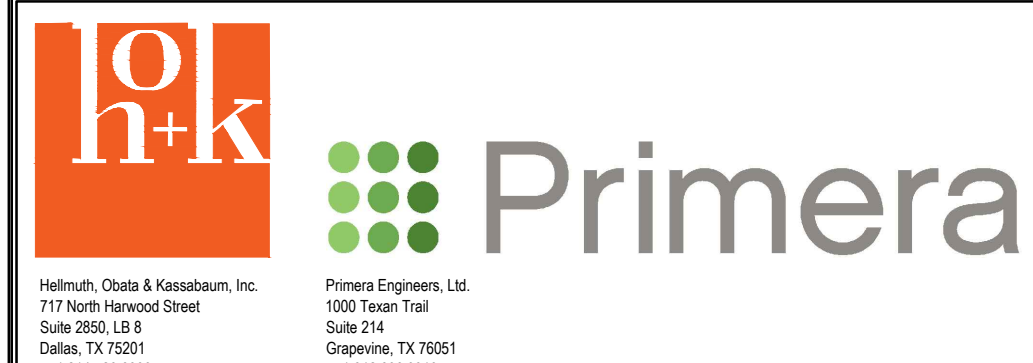

DRAWN BY: SJP
APPROVED BY: JMA
ISSUE DATE: 2022-07-28
NOT FOR BID OR CONSTRUCTION

NO:	DATE:	DESCRIPTION:
2022-07-28	100% DESIGN	
2022-07-28	100% DESIGN FOR PERMIT (D/P)	

TERMINAL C GARAGE & ROADWAYS
DEMOLITION PLAN (UPPER ROADWAY)

PROJECT NUMBER: TFD-007

PERMIT NUMBER: B22-0023

SHEET NUMBER
CD104-900R

SCALE(S) AS NOTED ON THIS SHEET ARE BASED ON A FULL SIZE 30 X 42 SHEET.

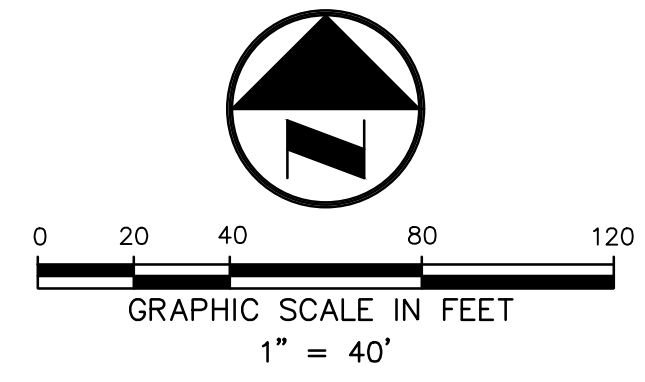

EXISTING LEGEND

- | | |
|------------------------------|----------------------------|
| • CRIADO CONTROL POINT | ⊠ ELECTRIC PULL BOX |
| • BOLLARD | ⊠ ELECTRIC METER |
| • GAS METER | ⊠ ELECTRIC BOX |
| ⊠ TRAFFIC SIGNAL LIGHT POLE | ⊠ ELECTRIC RISER |
| ⊠ TRAFFIC SIGNAL PULL BOX | ⊠ GROUND LIGHT SIGN |
| ⊠ TRAFFIC SIGNAL CONTROL BOX | ⊠ GAS PUMP |
| ⊠ TELECOM SERVICE BOX | ⊠ FUEL TANK VENT TREE |
| ⊠ TELECOM PEDESTAL | ⊠ BUSH |
| ⊠ CATV PEDESTAL | ⊠ WASTE WATER CLEANOUT |
| ⊠ CATV JUNCTION BOX | ⊠ WASTE WATER MANHOLE |
| ⊠ CATV APPURTENANCE | ⊠ STORM DRAIN MANHOLE |
| ⊠ LIGHT POLE | ⊠ WATER VALVE |
| ⊠ CATHODIC PROTECTION | ⊠ IRRIGATION CONTROL VALVE |
| ⊠ FLAG POLE | ⊠ SPRINKLER HEAD |
| ⊠ GENERIC MANHOLE | ⊠ SPIGOT |
| ⊠ POWER POLE | ⊠ FIRE HYDRANT |
| ⊠ GUYWIRE | ⊠ WATER METER |
| ⊠ ELECTRIC MANHOLE | ⊠ OVERHEAD UTILITY |
| | ⊠ OVERHEAD ELECTRIC |

GENERAL NOTES

1. ALL DIMENSIONS REFER TO FACE OF CURB UNLESS OTHERWISE NOTED.
2. BUILDING DIMENSIONS ARE TO THE OUTSIDE FACE OF BUILDING UNLESS OTHERWISE NOTED.
3. REFER TO ARCHITECTURAL AND STRUCTURAL PLANS TO VERIFY ALL BUILDING DIMENSIONS.
4. SEE MEP PLANS FOR SITE ELECTRICAL DRAWINGS.

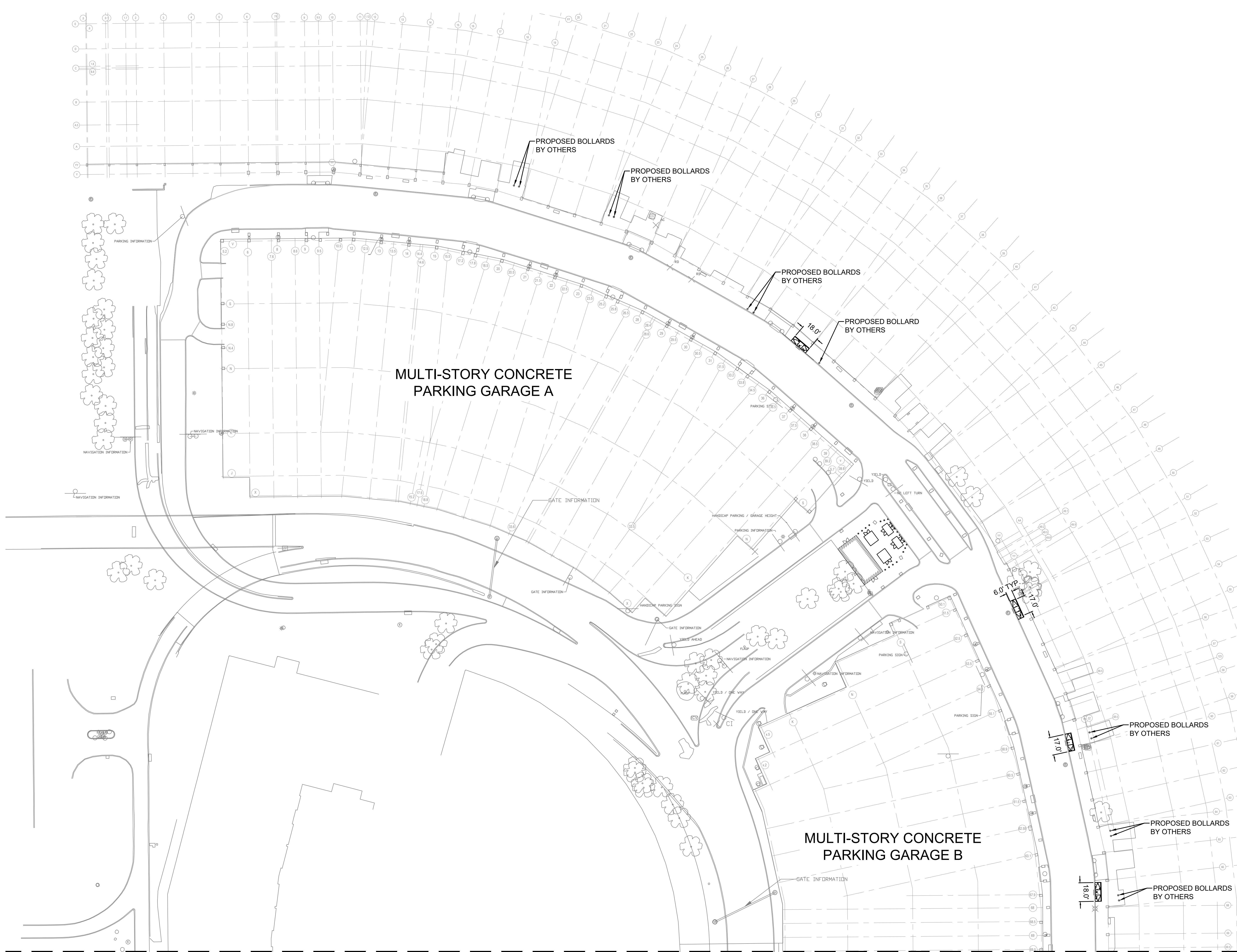

MATCHLINE - SEE SHEET CS102-900R

KEY PLAN

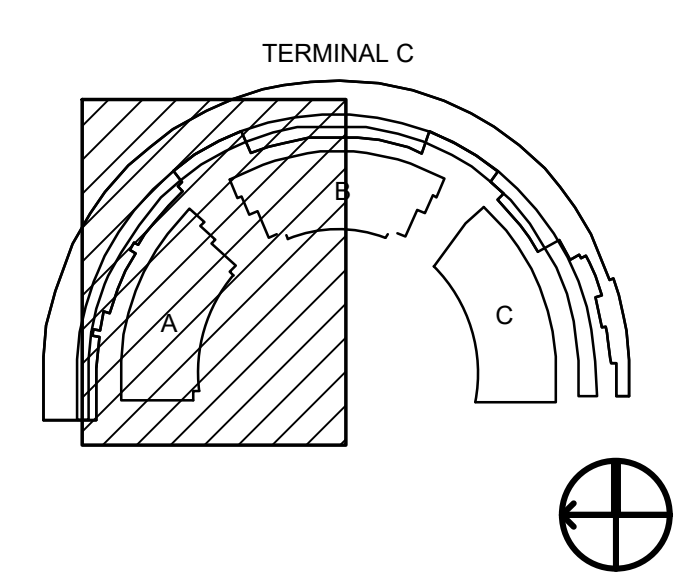

BORDER RELEASE DATE: October 16, 2021
 01/20/2021 10:59:09 AM
 C:\Users\jrc23\OneDrive\Documents\HOK\DAL\DFW\Int'l Airport - CTA Expansion Program\Project Files\01_CTA - Terminal C Garages and Roadways\CE\01 - CAD\Sheets\800\802-DFW-TC-CP1-4-0101-01m\Chp1Plan.dwg

DALLAS FORT WORTH INTERNATIONAL AIRPORT
 2330 N INTERNATIONAL PARKWAY
 DFW AIRPORT, TX 75261



Primera
 Project Engineers, LLC
 300 West 7th
 Suite 211
 Dallas, TX 75201
 (+1) 214 720 8000 (+1) 312 606 0910

DRAWN BY: SJP
 APPROVED BY: JMA
 ISSUE DATE: 2022-07-28
NOT FOR BID OR CONSTRUCTION

NO.	DATE	DESCRIPTION
2022-01-06		30% DESIGN
2022-03-01		100% DESIGN
2022-07-28		100% REVISED FOR PERMIT (RFP)

TERMINAL C GARAGE & ROADWAYS
DIMENSIONAL CONTROL PLAN (LOWER ROADWAY)
 PROJECT NUMBER: TFD-007
 PERMIT NUMBER: B22-0023

SHEET NUMBER
CS101-900R

SCALE(S) AS NOTED ON THIS SHEET ARE BASED ON A FULL SIZE 30 X 42 SHEET.

MATCHLINE - SEE SHEET CS101-900R

MULTI-STORY CONCRETE
PARKING GARAGE B

PROPOSED PARKING
GARAGE C

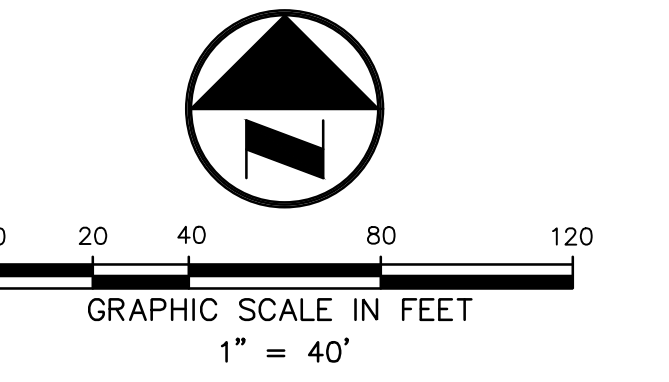

EXISTING LEGEND

- | | |
|------------------------------|----------------------------|
| • CRIADO CONTROL POINT | ⊠ ELECTRIC PULL BOX |
| • IRON ROD FOUND | ⊠ ELECTRIC METER |
| • BOLLARD | ⊠ ELECTRIC BOX |
| • GAS METER | ⊠ ELECTRIC RISER |
| ⊠ TRAFFIC SIGNAL LIGHT | ⊠ GROUND LIGHT |
| ⊠ POLE | ⊠ SIGN |
| ⊠ TRAFFIC SIGNAL PULL BOX | ⊠ GAS PUMP |
| ⊠ TRAFFIC SIGNAL CONTROL BOX | ⊠ FUEL TANK VENT |
| ⊠ TELECOM SERVICE BOX | ⊠ TREE |
| ⊠ TELECOM PEDESTAL | ⊠ BUSH |
| ⊠ CATV PEDESTAL | ⊠ WASTE WATER CLEANOUT |
| ⊠ CATV JUNCTION BOX | ⊠ WASTE WATER MANHOLE |
| ⊠ CATV APPURTENANCE | ⊠ STORM DRAIN MANHOLE |
| ⊠ LIGHT POLE | ⊠ WATER VALVE |
| ⊠ CATHODIC PROTECTION | ⊠ IRRIGATION CONTROL VALVE |
| ⊠ FLAG POLE | ⊠ SPRINKLER HEAD |
| ⊠ GENERIC MANHOLE | ⊠ SPIGOT |
| ⊠ POWER POLE | ⊠ FIRE HYDRANT |
| ⊠ GUYWIRE | ⊠ WATER METER |
| ⊠ ELECTRIC MANHOLE | ⊠ OVERHEAD UTILITY |
| | ⊠ OVERHEAD ELECTRIC |

GENERAL NOTES

1. ALL DIMENSIONS REFER TO FACE OF CURB UNLESS OTHERWISE NOTED.
2. BUILDING DIMENSIONS ARE TO THE OUTSIDE FACE OF BUILDING UNLESS OTHERWISE NOTED.
3. REFER TO ARCHITECTURAL AND STRUCTURAL PLANS TO VERIFY ALL BUILDING DIMENSIONS.
4. SEE MEP PLANS FOR SITE ELECTRICAL DRAWINGS.

KEY PLAN

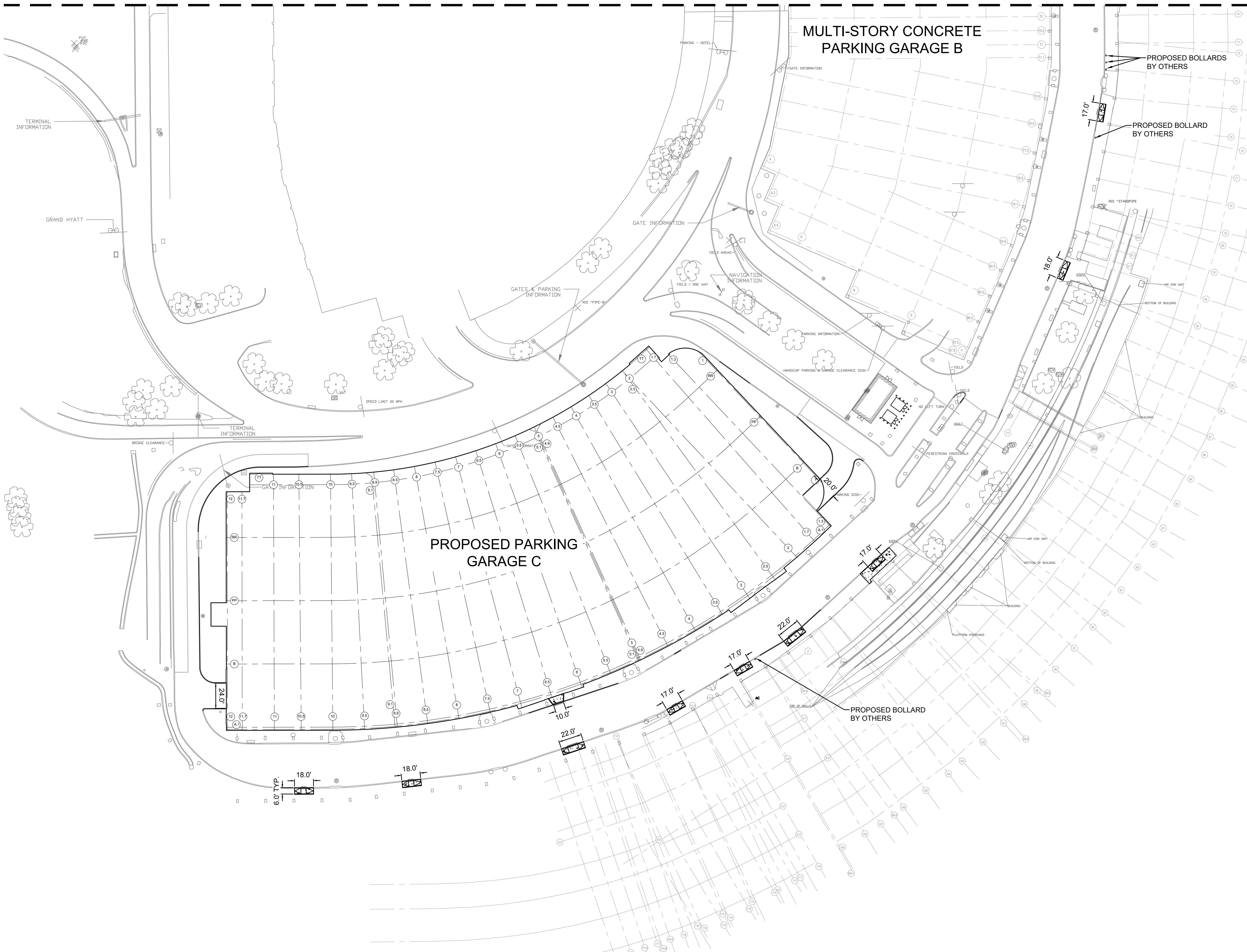
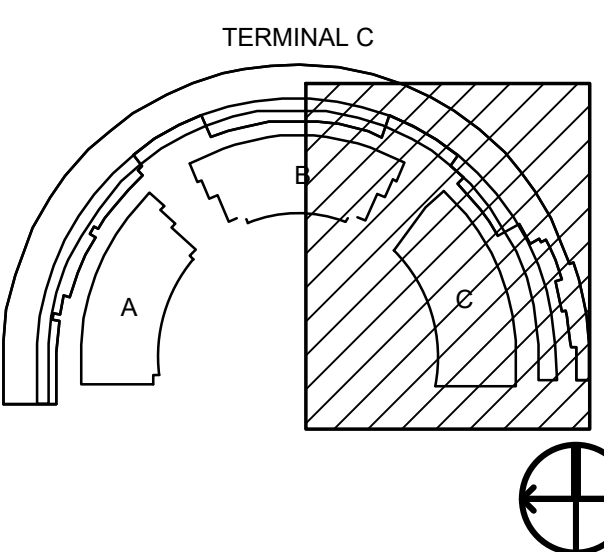

DFW DALLAS FORT WORTH INTERNATIONAL AIRPORT
2330 N INTERNATIONAL PARKWAY
DFW AIRPORT, TX 75261



h+k Primera
Primera Engineers, Ltd.
300 West 7th
Suite 211
Dallas, TX 75201
+1 214 720 8000 +1 312 606 0910

DRAWN BY: SJP
APPROVED BY: JMA
ISSUE DATE: 2022-07-28
NOT FOR BID OR CONSTRUCTION

NO.	DATE	DESCRIPTION
2022-01-06	30% DESIGN	
2022-03-01	100% DESIGN	
2022-02-28	100% SUBMITTED FOR PERMIT (SFP)	

TERMINAL C GARAGE & ROADWAYS
DIMENSIONAL CONTROL PLAN (LOWER ROADWAY)
PROJECT NUMBER: TFD-007
PERMIT NUMBER: B22-0023

SHEET NUMBER
CS102-900R

SCALE(S) AS NOTED ON THIS SHEET ARE BASED ON A FULL SIZE 30 X 42 SHEET.

BORDER RELEASE DATE: October 16, 2021
01/22/2021 10:59:09 AM C:\Users\jmc2020\OneDrive\Documents\Projects\DFW\Terminal C\Garages and Roadways\CE01 - CAD\Sheets\B220023.DWG - Terminal C Garages and Roadways\CE01 - CAD\Sheets\B220023.DWG - Terminal C Garages and Roadways\CE01 - CAD\Sheets\B220023.DWG

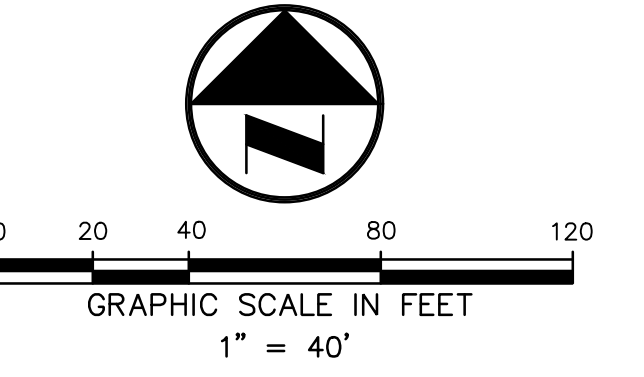

EXISTING LEGEND

- CRIADO CONTROL POINT
- IRON ROD FOUND
- BOLLARD
- GAS METER
- TRAFFIC SIGNAL LIGHT POLE
- TRAFFIC SIGNAL PULL BOX
- TRAFFIC SIGNAL CONTROL BOX
- TELECOM SERVICE BOX
- TELECOM PEDESTAL
- TELECOM MANHOLE
- CATV PEDESTAL
- CATV JUNCTION BOX
- CATV APPURTENANCE
- LIGHT POLE
- CATHODIC PROTECTION
- FLAG POLE
- GENERIC MANHOLE
- POWER POLE
- GUYWIRE
- ELECTRIC MANHOLE
- ELECTRIC PULL BOX
- ELECTRIC METER
- ELECTRIC BOX
- GAS METER
- GROUND LIGHT SIGN
- GAS PUMP
- FUEL TANK VENT
- TREE
- BUSH
- WASTE WATER CLEANOUT
- WASTE WATER MANHOLE
- STORM DRAIN MANHOLE
- WATER VALVE
- IRRIGATION CONTROL VALVE
- SPRINKLER HEAD
- SPIGOT
- FIRE HYDRANT
- WATER METER
- OVERHEAD UTILITY
- OVERHEAD ELECTRIC

GENERAL NOTES

1. ALL DIMENSIONS REFER TO FACE OF CURB UNLESS OTHERWISE NOTED.
2. BUILDING DIMENSIONS ARE TO THE OUTSIDE FACE OF BUILDING UNLESS OTHERWISE NOTED.
3. REFER TO ARCHITECTURAL AND STRUCTURAL PLANS TO VERIFY ALL BUILDING DIMENSIONS.
4. SEE MEP PLANS FOR SITE ELECTRICAL DRAWINGS.

KEY PLAN

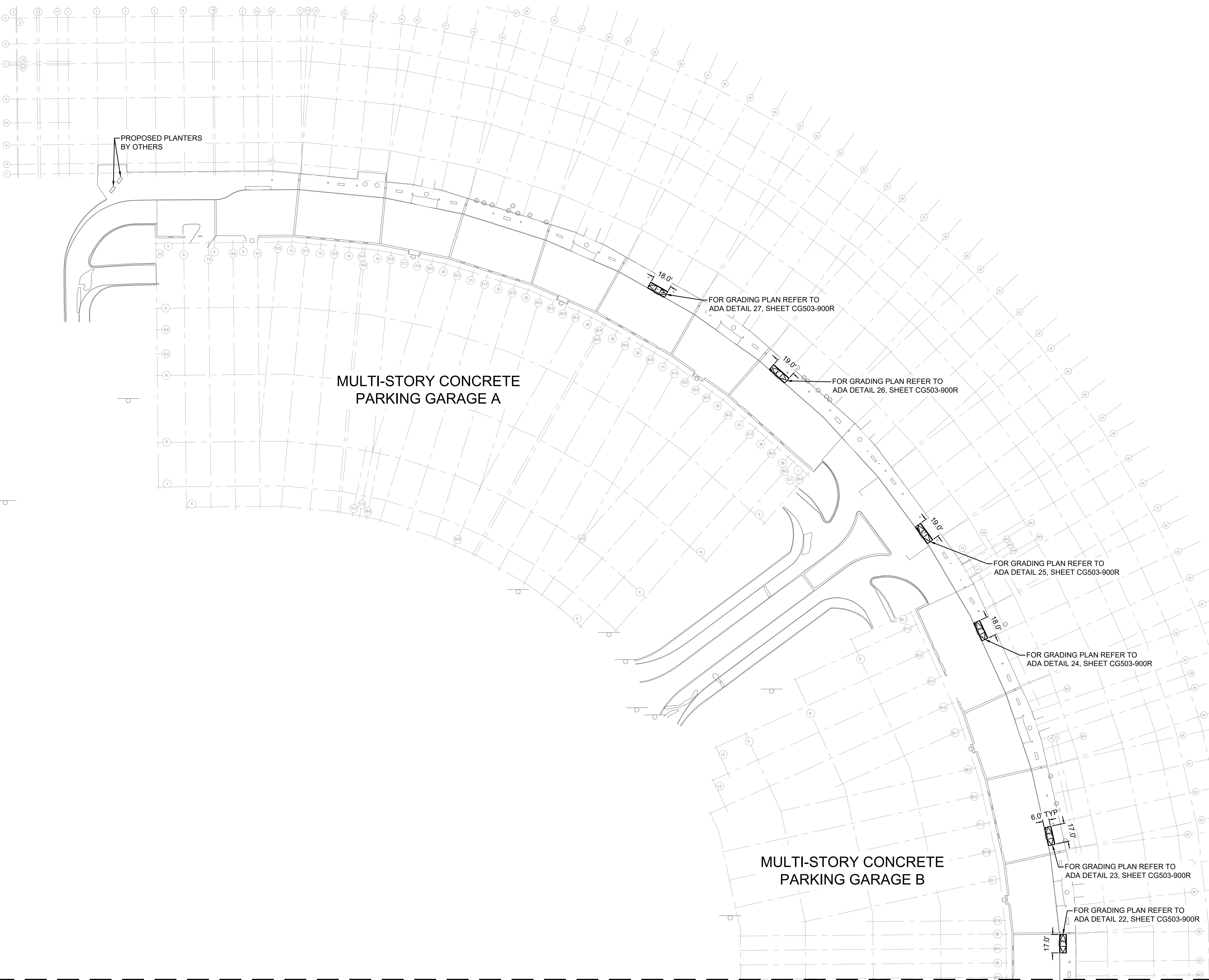
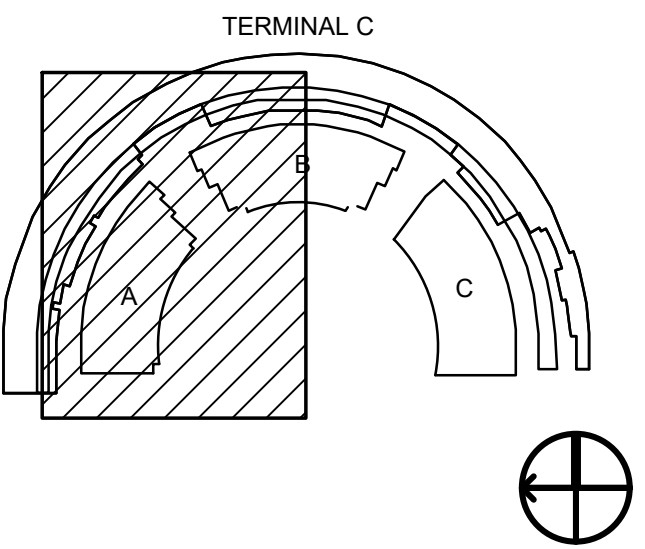

MATCHLINE - SEE SHEET CS104-900R

BORDER RELEASE DATE: October 16, 2021
 01/22/2021 10:09:09 AM C:\Users\jmc2020\OneDrive\Documents\HOK\DAL\DFW\Int'l Airport - CTA Expansion Program\Project Files\01_CTA - Terminal C Garages and Roadways\CE/01 - CAD/Sheets/85000082_DFW-TC-CS104-900R-DimControlUpper.dwg

DFW DALLAS FORT WORTH INTERNATIONAL AIRPORT

2330 N INTERNATIONAL PARKWAY
DFW AIRPORT, TX 75261



h+k Primera

Primera Engineers, LLC
 300 West 7th
 Suite 200, LB #
 Dallas, TX 75201
 (+1) 214 720 8000 (+1) 312 606 0910

DRAWN BY: SJP
 APPROVED BY: JMA
 ISSUE DATE: 2022-07-28

NOT FOR BID OR CONSTRUCTION

NO.	DATE	DESCRIPTION
1	2022-09-01	100% DESIGN
2	2022-07-28	100% SUBMIT FOR PERMIT (SFP)

TERMINAL C GARAGE & ROADWAYS

DIMENSIONAL CONTROL PLAN (UPPER ROADWAY)

PROJECT NUMBER: TFD-007

PERMIT NUMBER: B22-0023

SHEET NUMBER
CS103-900R

SCALE(S) AS NOTED ON THIS SHEET ARE BASED ON A FULL SIZE 30 X 42 SHEET.

MATCHLINE - SEE SHEET CS103-900R

MULTI-STORY CONCRETE
PARKING GARAGE B

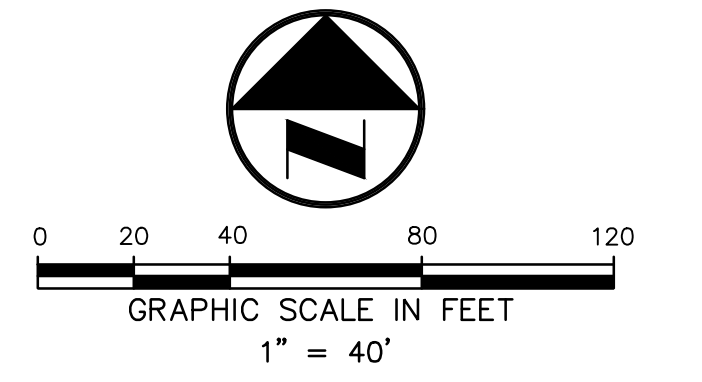

EXISTING LEGEND

- | | |
|------------------------------|----------------------------|
| • CRIADO CONTROL POINT | ⊠ ELECTRIC PULL BOX |
| • IRON ROD FOUND | ⊠ ELECTRIC METER |
| • BOLLARD | ⊠ ELECTRIC BOX |
| • GAS METER | ⊠ ELECTRIC RISER |
| • TRAFFIC SIGNAL LIGHT | ⊠ GROUND LIGHT |
| • POLE | ⊠ SIGN |
| • TRAFFIC SIGNAL PULL BOX | • GAS PUMP |
| • TRAFFIC SIGNAL CONTROL BOX | • FUEL TANK VENT |
| • TELECOM SERVICE BOX | • TREE |
| • TELECOM PEDESTAL | • BUSH |
| • TELECOM MANHOLE | • WASTE WATER CLEANOUT |
| • CATV PEDESTAL | • WASTE WATER MANHOLE |
| • CATV JUNCTION BOX | • STORM DRAIN MANHOLE |
| • CATV APPURTENANCE | • WATER VALVE |
| • LIGHT POLE | • IRRIGATION CONTROL VALVE |
| • CATHODIC PROTECTION | • SPRINKLER HEAD |
| • FLAG POLE | • SPIGOT |
| • GENERIC MANHOLE | • FIRE HYDRANT |
| • POWER POLE | • WATER METER |
| • GUYWIRE | • OVERHEAD UTILITY |
| • ELECTRIC MANHOLE | • OVERHEAD ELECTRIC |

GENERAL NOTES

1. ALL DIMENSIONS REFER TO FACE OF CURB UNLESS OTHERWISE NOTED.
2. BUILDING DIMENSIONS ARE TO THE OUTSIDE FACE OF BUILDING UNLESS OTHERWISE NOTED.
3. REFER TO ARCHITECTURAL AND STRUCTURAL PLANS TO VERIFY ALL BUILDING DIMENSIONS.
4. SEE MEP PLANS FOR SITE ELECTRICAL DRAWINGS.

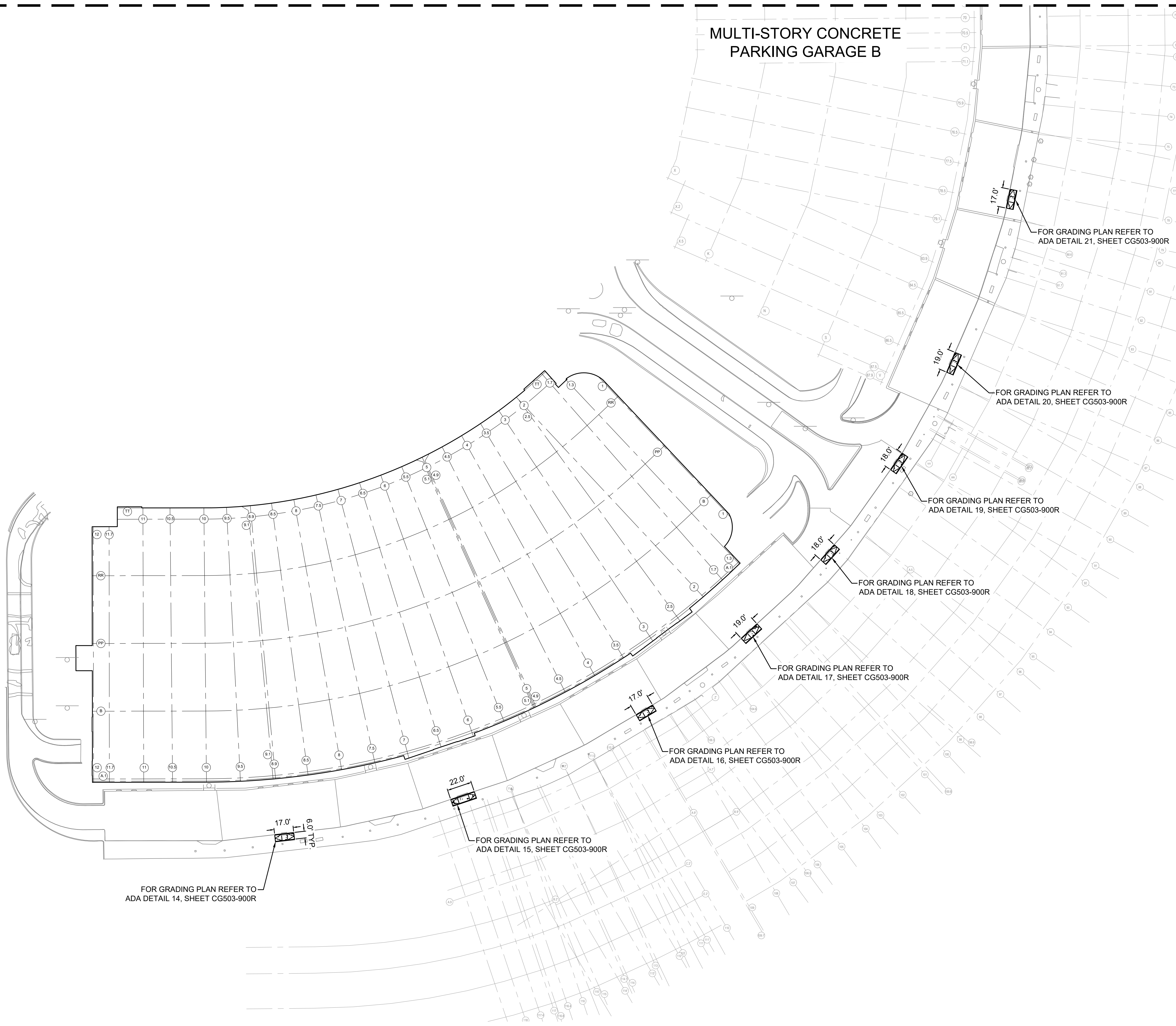

KEY PLAN

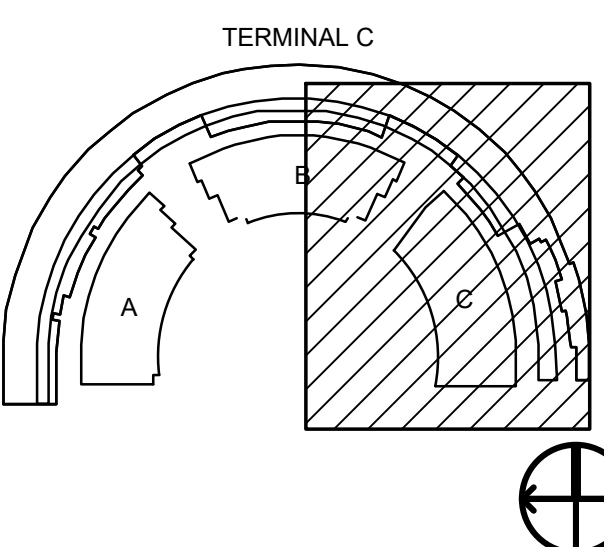

BORDER RELEASE DATE: October 16, 2021
01/20/2021 10:09:09 AM C:\Users\jmc2020\OneDrive\Documents\CS104-900R-DIM-UPPER.dwg



2330 N INTERNATIONAL PARKWAY
DFW AIRPORT, TX 75261

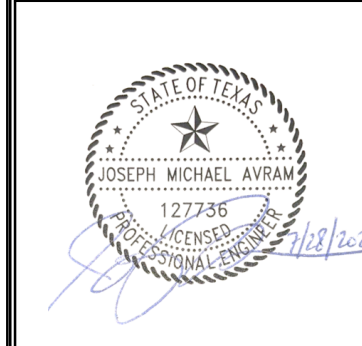

DRAWN BY: SJP
APPROVED BY: JMA
ISSUE DATE: 2022-07-28
NOT FOR BID OR CONSTRUCTION

NO.	DATE	DESCRIPTION
1	2022-07-28	100% DESIGN
2	2022-07-28	100% SUBMITTED FOR PERMIT (SFP)

TERMINAL C GARAGE & ROADWAYS
DIMENSIONAL CONTROL PLAN (UPPER ROADWAY)
PROJECT NUMBER: TFD-007
PERMIT NUMBER: B22-0023

SHEET NUMBER
CS104-900R

SCALE(S) AS NOTED ON THIS SHEET ARE BASED ON A FULL SIZE 30 X 42 SHEET.

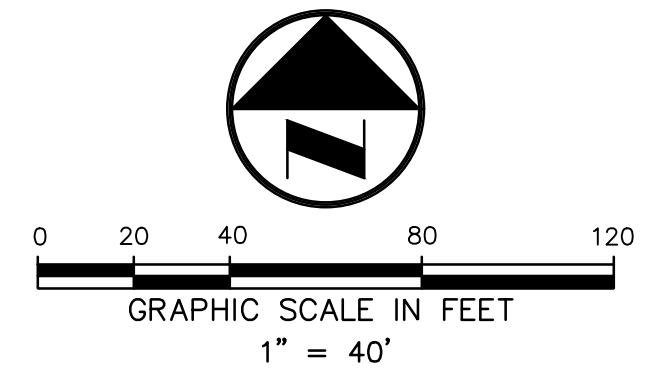

EXISTING LEGEND

- CRIADO CONTROL POINT
- IRON ROD FOUND
- BOLLARD
- GAS METER
- TRAFFIC SIGNAL LIGHT POLE
- TRAFFIC SIGNAL PULL BOX
- TRAFFIC SIGNAL CONTROL BOX
- TELECOM SERVICE BOX
- TELECOM PEDESTAL
- TELECOM MANHOLE
- CATV PEDESTAL
- CATV JUNCTION BOX
- CATV APPURTENANCE
- LIGHT POLE
- CATHODIC PROTECTION
- FLAG POLE
- GENERIC MANHOLE
- POWER POLE
- GUYWIRE
- ELECTRIC MANHOLE
- ELECTRIC PULL BOX
- ELECTRIC METER
- ELECTRIC BOX
- ELECTRIC RISER
- GROUND LIGHT SIGN
- GAS PUMP
- FUEL TANK VENT
- TREE
- BUSH
- WASTE WATER CLEANOUT
- WASTE WATER MANHOLE
- STORM DRAIN MANHOLE
- WATER VALVE
- IRRIGATION CONTROL VALVE
- SPRINKLER HEAD
- SPIGOT
- FIRE HYDRANT
- WATER METER
- OVERHEAD UTILITY
- OVERHEAD ELECTRIC

PROPOSED LEGEND

- PAVEMENT RESURFACING (REFER TO SHEET CP501-900R)
- CONCRETE SIDEWALK (REFER TO SHEET CP501-900R)
- PROPOSED CURB & GUTTER
- PROPOSED DEPRESSED CURB & GUTTER

NOTES:

1. SEE UPPER ROADWAY PHASING SEQUENCING NOTES ON SHEET CT100-900R FOR ADDITIONAL DETAIL.
2. EXISTING BRIDGE FOOTINGS, COLUMNS, RETAINING WALLS AND OVERHEAD ELEMENTS ARE TO REMAIN. CONTRACTOR TO USE THE UTMOST CARE AROUND THEM AND NOT UNDERMINE ANY PART. IF THE CONTRACTOR HITS/DAMAGES ANY BRIDGE PARTS, THEY NEED TO CONTACT THE OWNER'S REPRESENTATIVE IMMEDIATELY. ANY REPAIRS AS A RESULT OF CONTRACTOR ACTIVITY IS THE RESPONSIBILITY OF THE CONTRACTOR.
3. EXISTING CURBS AND SIDE WALKS TO REMAIN UNLESS SPECIFICALLY SHOWN TO BE REMOVED. CONTRACTOR TO USE THE UTMOST CARE AROUND THEM AND NOT UNDERMINE ANY PART. IF THE CONTRACTOR HITS/DAMAGES ANY BRIDGE PARTS, THEY NEED TO CONTACT THE OWNER'S REPRESENTATIVE IMMEDIATELY. ANY REPAIRS AS A RESULT OF CONTRACTOR ACTIVITY IS THE RESPONSIBILITY OF THE CONTRACTOR.

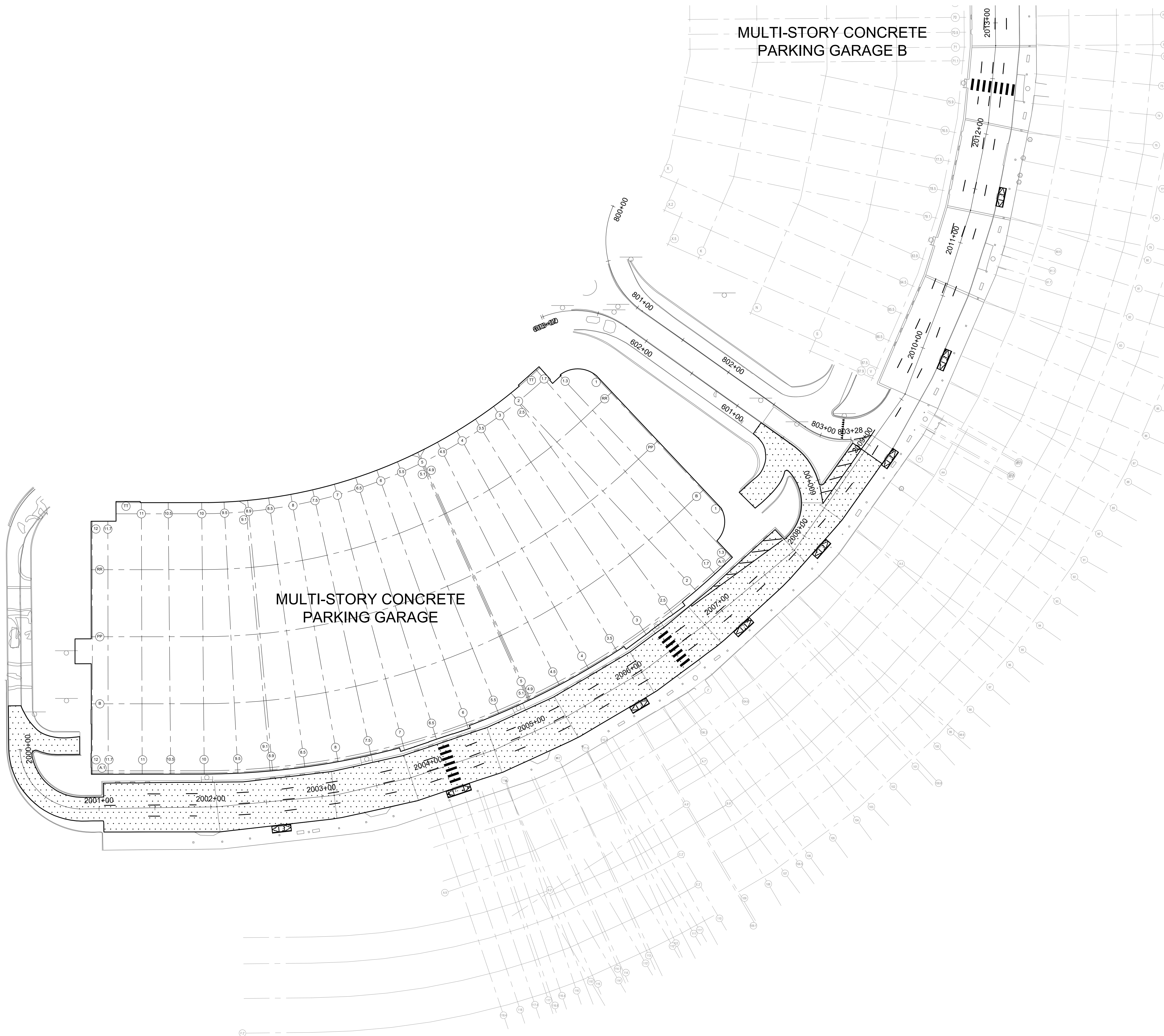

KEY PLAN

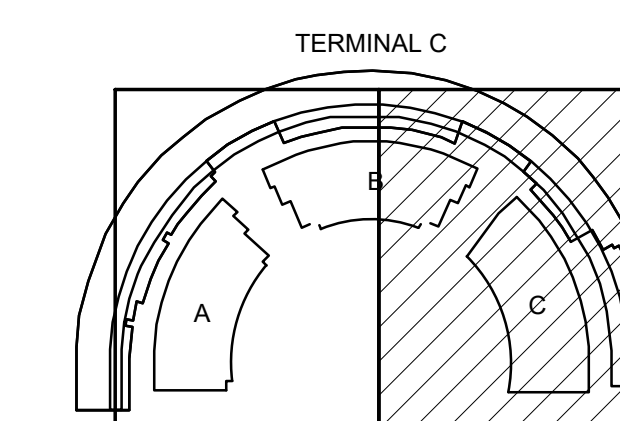

BORDER RELEASE DATE: October 16, 2021
 01/20/2021 10:59:09 AM C:\Users\jmc2020\OneDrive\Documents\hok\DFW\Int'l Airport - CTA Expansion Program\Project Files\01_CTA - Terminal C Garages and Roadways\CP102-900R-RoadwayUpper.dwg



2330 N INTERNATIONAL PARKWAY
DFW AIRPORT, TX 75261

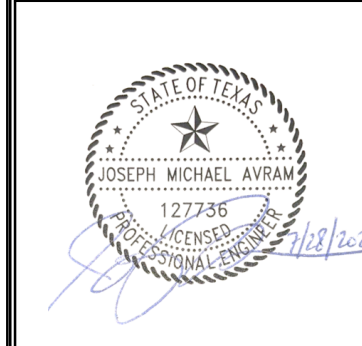

DRAWN BY: SJP
 APPROVED BY: JMA
 ISSUE DATE: 2022-07-28
NOT FOR BID OR CONSTRUCTION

NO.	DATE	DESCRIPTION
0001	01-20-20	30% DESIGN
0002	01-09	30% DESIGN
0003	05-01	100% DESIGN
0004	07-28	100% DESIGN FOR PERMIT (D/P)

TERMINAL C GARAGE & ROADWAYS
PHASE 1 PAVING PLAN (UPPER ROADWAY)
 PROJECT NUMBER: TFD-007
 PERMIT NUMBER: B22-0023

SHEET NUMBER
CP102-900R

SCALE(S) AS NOTED ON THIS SHEET ARE BASED ON A FULL SIZE 30 X 42 SHEET.

MATCHLINE - SEE SHEET CP103-900R

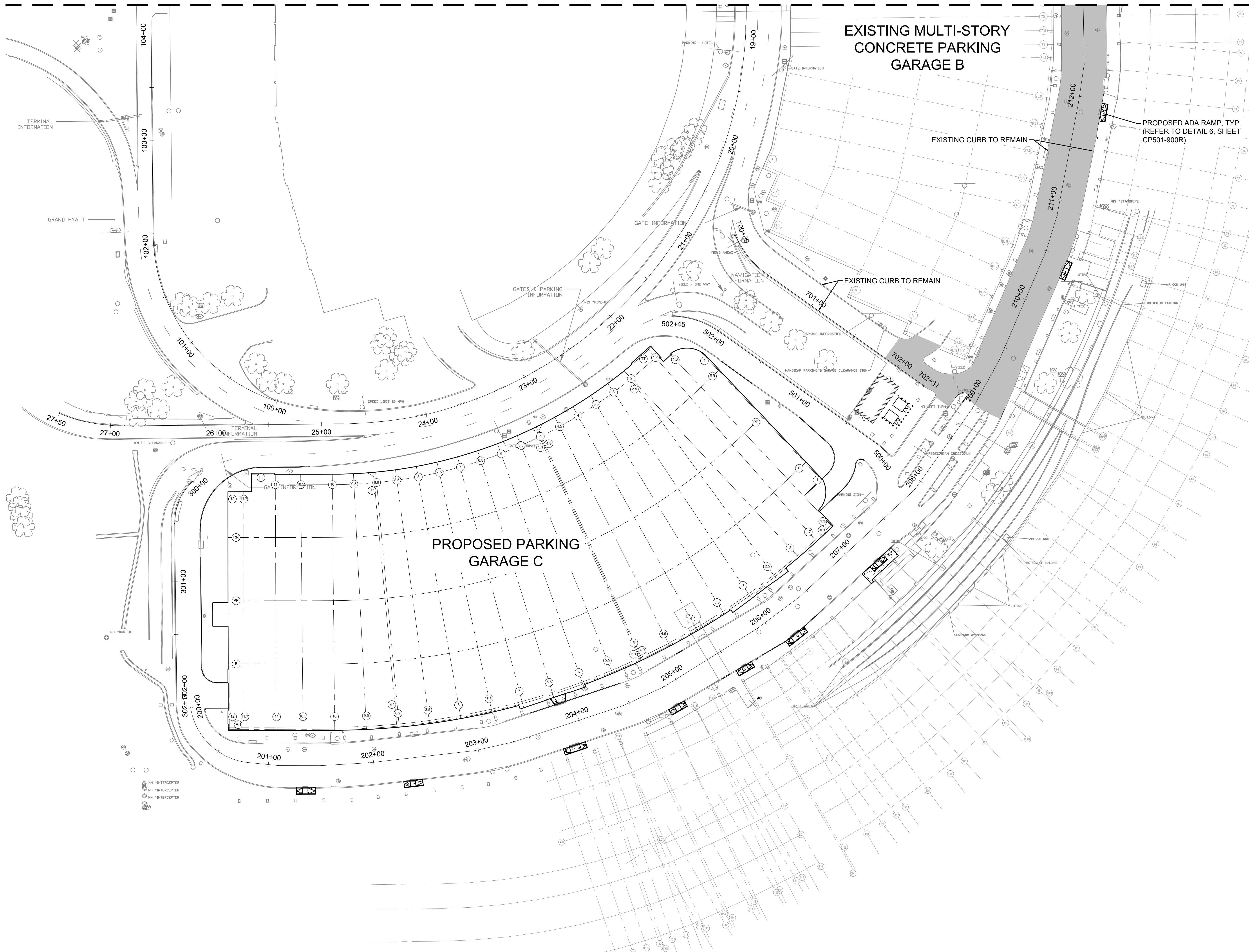
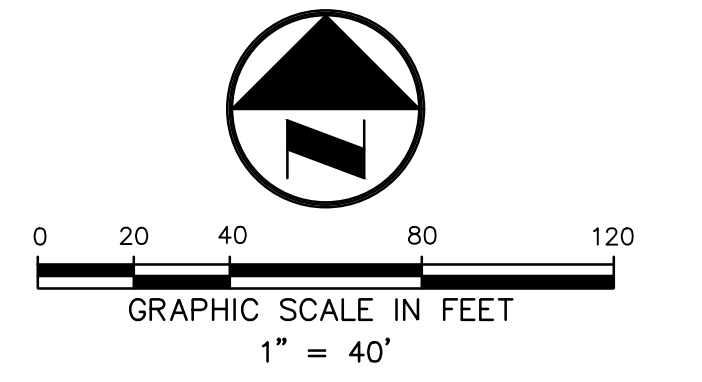

EXISTING LEGEND

- CRIADO CONTROL POINT
- IRON ROD FOUND
- BOLLARD
- GAS METER
- TRAFFIC SIGNAL LIGHT POLE
- TRAFFIC SIGNAL PULL BOX
- TRAFFIC SIGNAL CONTROL BOX
- TELECOM SERVICE BOX
- TELECOM PEDESTAL
- CATV PEDESTAL
- CATV JUNCTION BOX
- CATV APPURTENANCE
- LIGHT POLE
- CATHODIC PROTECTION
- FLAG POLE
- GENERIC MANHOLE
- POWER POLE
- GUYWIRE
- ELECTRIC MANHOLE
- ELECTRIC PULL BOX
- ELECTRIC METER
- ELECTRIC BOX
- ELECTRIC RISER
- GROUND LIGHT SIGN
- GAS PUMP
- FUEL TANK VENT
- TREE
- BUSH
- WASTE WATER CLEANOUT
- WASTE WATER MANHOLE
- STORM DRAIN MANHOLE
- WATER VALVE
- IRRIGATION CONTROL VALVE
- SPRINKLER HEAD
- SPIGOT
- FIRE HYDRANT
- WATER METER
- OVERHEAD UTILITY
- OVERHEAD ELECTRIC

PROPOSED LEGEND

- FULL-DEPTH CONCRETE PAVEMENT
- CONCRETE SIDEWALK (REFER TO SHEET CP501-900R)
- PROPOSED CURB & GUTTER
- PROPOSED DEPRESSED CURB & GUTTER
- PROPOSED RETAINING WALL
- PROPOSED ADA RAMP

NOTES:

1. SEE LOWER ROADWAY PHASING SEQUENCING NOTES ON SHEET CT100-900R FOR ADDITIONAL DETAIL.
2. SEE SHEETS CP501-900R & CP502-900R FOR PAVEMENT SECTION AND DETAILS.
3. CONTRACTOR TO SUBMIT JOINT LAYOUT PLAN BASED ON PROJECT PHASING AND TXDOT STANDARDS.
4. EXISTING BRIDGE FOOTINGS, COLUMNS, RETAINING WALLS AND OVERHEAD ELEMENTS ARE TO REMAIN. CONTRACTOR TO USE THE UTMOST CARE AROUND THEM AND NOT UNDERMINE ANY PART. IF THE CONTRACTOR HITS/DAMAGES ANY BRIDGE PARTS, THEY NEED TO CONTACT THE OWNER'S REPRESENTATIVE IMMEDIATELY. ANY REPAIRS AS A RESULT OF CONTRACTOR ACTIVITY IS THE RESPONSIBILITY OF THE CONTRACTOR.
5. EXISTING CURBS AND SIDE WALKS TO REMAIN UNLESS SPECIFICALLY SHOWN TO BE REMOVED. CONTRACTOR TO USE THE UTMOST CARE AROUND THEM AND NOT UNDERMINE ANY PART. IF THE CONTRACTOR HITS/DAMAGES ANY BRIDGE PARTS, THEY NEED TO CONTACT THE OWNER'S REPRESENTATIVE IMMEDIATELY. ANY REPAIRS AS A RESULT OF CONTRACTOR ACTIVITY IS THE RESPONSIBILITY OF THE CONTRACTOR.

KEY PLAN

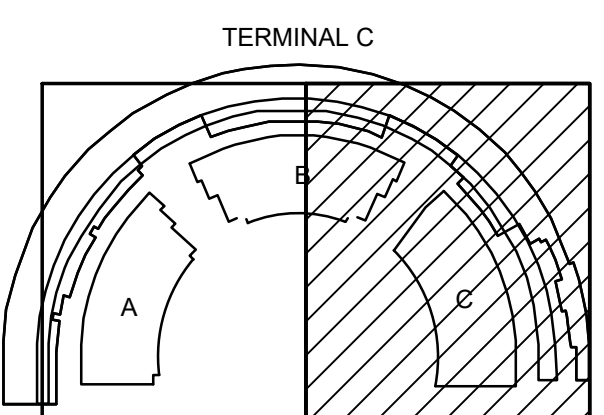

BORDER RELEASE DATE: October 16, 2021
 01/20/2021 10:09:09 AM C:\Users\jmc2020\OneDrive\Documents\DFW\CP104-900R\CP104-900R\Roadway\Lower.dwg
 C:\Users\jmc2020\OneDrive\Documents\DFW\CP104-900R\Terminal C Garages and Roadways\CP104-900R\Terminal C Garages and Roadways\Lower.dwg

DALLAS
FORT WORTH
INTERNATIONAL
AIRPORT

2330 N INTERNATIONAL PARKWAY
DFW AIRPORT, TX 75261



Primera
 Engineers, Inc.
 300 West 7th
 Suite 200, LB #
 Dallas, TX 75201
 (+1) 214 720 8000

DRAWN BY: SJP
 APPROVED BY: JMA
 ISSUE DATE: 2022-07-28
NOT FOR BID OR CONSTRUCTION

NO.	DATE	DESCRIPTION
0001	01-20-20	30% DESIGN
0002	01-06	30% DESIGN
0003	01-01	100% DESIGN
0004	01-28	100% DESIGN FOR PERMIT (D/P)

TERMINAL C GARAGE & ROADWAYS
PHASE 2 PAVING PLAN (LOWER ROADWAY)

PROJECT NUMBER: TFD-007

PERMIT NUMBER: B22-0023

SHEET NUMBER
CP104-900R

SCALE(S) AS NOTED ON THIS SHEET ARE BASED ON A FULL SIZE 30 X 42 SHEET.

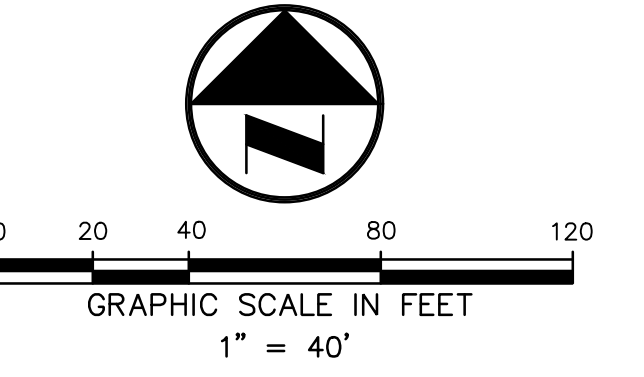

PROPOSED PLANTERS
BY OTHERS

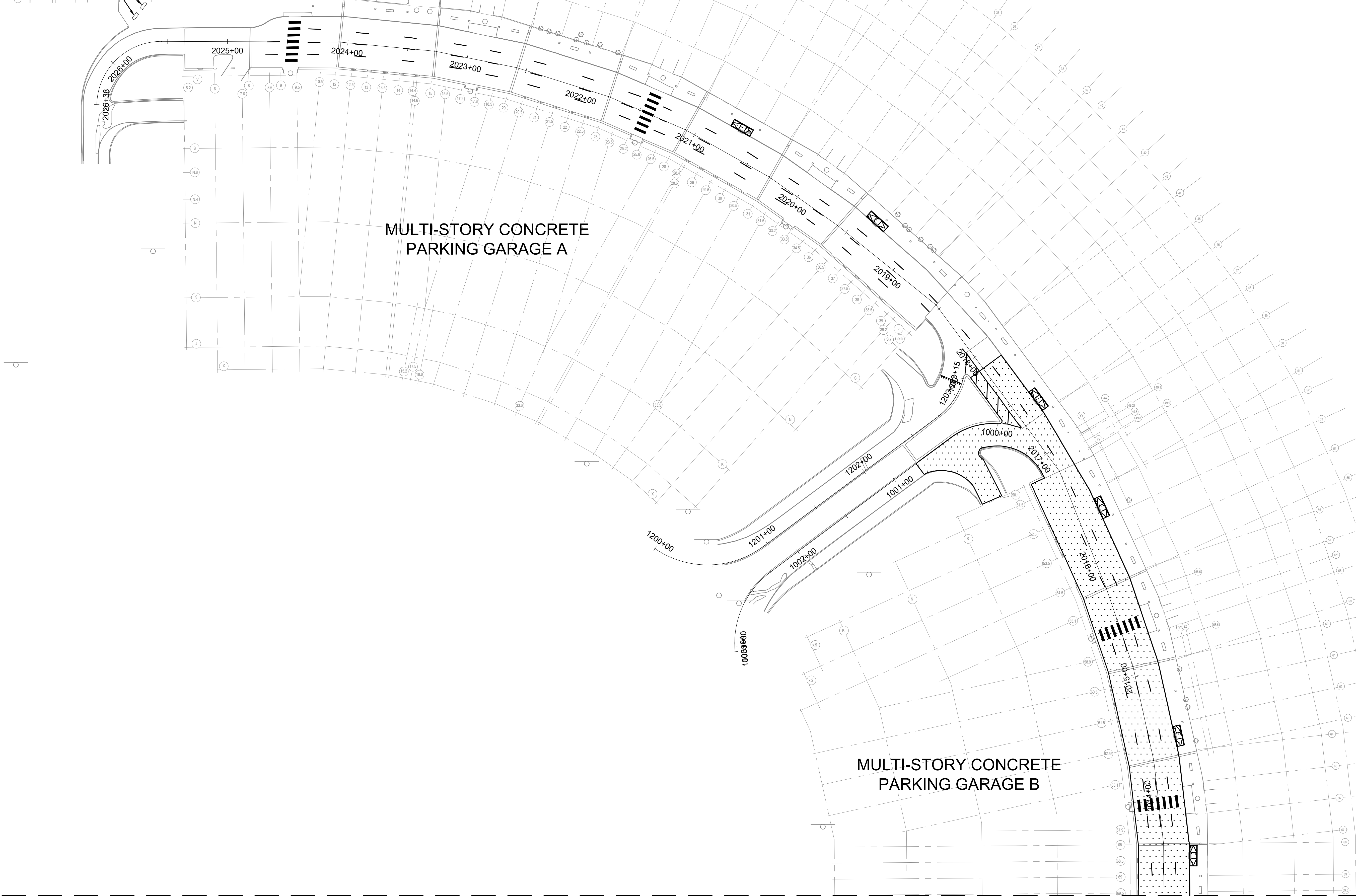

EXISTING LEGEND

- CRIADO CONTROL POINT
- IRON ROD FOUND
- BOLLARD
- GAS METER
- TRAFFIC SIGNAL LIGHT POLE
- TRAFFIC SIGNAL PULL BOX
- TRAFFIC SIGNAL CONTROL BOX
- TELECOM SERVICE BOX
- TELECOM PEDESTAL
- TELECOM MANHOLE
- CATV PEDESTAL
- CATV JUNCTION BOX
- CATV APPURTENANCE
- LIGHT POLE
- CATHODIC PROTECTION
- FLAG POLE
- GENERIC MANHOLE
- POWER POLE
- GUYWIRE
- ELECTRIC MANHOLE
- ELECTRIC PULL BOX
- ELECTRIC METER
- ELECTRIC BOX
- ELECTRIC RISER
- GROUND LIGHT SIGN
- GAS PUMP
- FUEL TANK VENT
- TREE
- BUSH
- WASTE WATER CLEANOUT
- WASTE WATER MANHOLE
- STORM DRAIN MANHOLE
- WATER VALVE
- IRRIGATION CONTROL VALVE
- SPRINKLER HEAD
- SPIGOT
- FIRE HYDRANT
- WATER METER
- OVERHEAD UTILITY
- OVERHEAD ELECTRIC

PROPOSED LEGEND

- ▨ PAVEMENT RESURFACING (REFER TO SHEET CP501-900R)
- ▨ CONCRETE SIDEWALK (REFER TO SHEET CP501-900R)
- PROPOSED CURB & GUTTER
- PROPOSED DEPRESSED CURB & GUTTER

NOTES:

1. SEE UPPER ROADWAY PHASING SEQUENCING NOTES ON SHEET CT100-900R FOR ADDITIONAL DETAIL.
2. EXISTING BRIDGE FOOTINGS, COLUMNS, RETAINING WALLS AND OVERHEAD ELEMENTS ARE TO REMAIN. CONTRACTOR TO USE THE UTMOST CARE AROUND THEM AND NOT UNDERMINE ANY PART. IF THE CONTRACTOR HITS/DAMAGES ANY BRIDGE PARTS, THEY NEED TO CONTACT THE OWNER'S REPRESENTATIVE IMMEDIATELY. ANY REPAIRS AS A RESULT OF CONTRACTOR ACTIVITY IS THE RESPONSIBILITY OF THE CONTRACTOR.
3. EXISTING CURBS AND SIDE WALKS TO REMAIN UNLESS SPECIFICALLY SHOWN TO BE REMOVED. CONTRACTOR TO USE THE UTMOST CARE AROUND THEM AND NOT UNDERMINE ANY PART. IF THE CONTRACTOR HITS/DAMAGES ANY BRIDGE PARTS, THEY NEED TO CONTACT THE OWNER'S REPRESENTATIVE IMMEDIATELY. ANY REPAIRS AS A RESULT OF CONTRACTOR ACTIVITY IS THE RESPONSIBILITY OF THE CONTRACTOR.

MATCHLINE - SEE SHEET CP106-900R

KEY PLAN

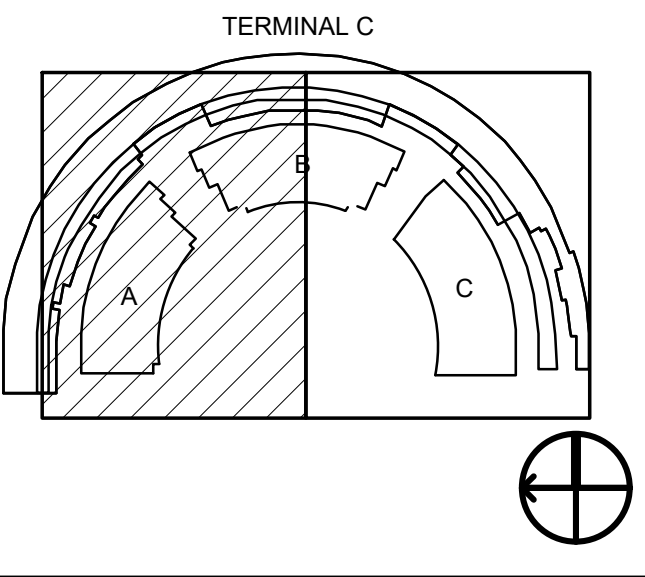

BORDER RELEASE DATE: October 16, 2021
01/20/2021 10:59:09 AM C:\Users\jmc2020\OneDrive\Documents\CP105-900R.dwg
C:\Users\jmc2020\OneDrive\Documents\CP105-900R.dwg - Terminal C Garages and Roadways - CTA Expansion Program\Project Files\01_CTA - Terminal C Garages and Roadways\CP105-900R.dwg



2330 N INTERNATIONAL PARKWAY
DFW AIRPORT, TX 75261



DRAWN BY: SJP
APPROVED BY: JMA
ISSUE DATE: 2022-07-28
NOT FOR BID OR CONSTRUCTION

NO.	DATE	DESCRIPTION
0001	2022-01-28	30% DESIGN
0002	2022-01-28	30% DESIGN
0003	2022-01-28	100% DESIGN
0004	2022-07-28	100% REVISED FOR PERMIT (RFP)

TERMINAL C GARAGE & ROADWAYS
PHASE 2 PAVING PLAN (UPPER ROADWAY)
PROJECT NUMBER: TFD-007
PERMIT NUMBER: B22-0023

SHEET NUMBER
CP105-900R

SCALE(S) AS NOTED ON THIS SHEET ARE BASED ON A FULL SIZE 30 X 42 SHEET.

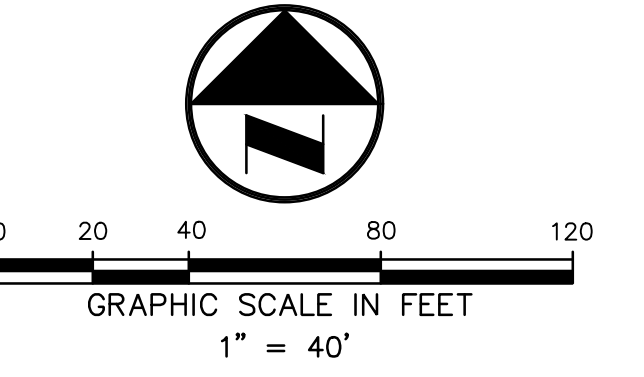

LEGEND

- LEVEL A = WORK TO BE COMPLETED DURING PHASE 1
- LEVEL B = WORK TO BE COMPLETED DURING PHASE 1
- LEVEL C = WORK TO BE COMPLETED DURING PHASE 3

- NOTES:**
1. FIELD INSPECTION REQUIRED TO DETERMINE EXACT SIZE AND LOCATION OF REPAIRS.
 2. SEE TXDOT STANDARD RECP-14 ON SHEET CP502-900R FOR ADDITIONAL DETAIL.
 3. SEE LOWER ROADWAY PHASING SEQUENCING NOTES ON SHEET CT100-900R FOR ADDITIONAL DETAIL.
 4. SEE LOWER LEVEL DEMOLITION PLANS ON SHEETS CD101-900R & CD102-900R FOR ADDITIONAL DETAIL.
 5. PAVEMENT REPAIR HATCHING ARE APPROXIMATE. DIMENSIONS PROVIDED ARE BASED ON SITE VISIT CONDUCTED IN 2021. PRIOR TO START OF WORK, CONTRACTOR IS TO PERFORM INSPECTION TO CONFIRM LIMITS OF PAVEMENT REPLACEMENT. IF THE LIMITS OF PAVEMENT DETERIORATION EXCEED THE ESTIMATED QUANTITY SHOWN IN THE DRAWINGS, THE CONTRACTOR IS TO CONTACT OWNER'S REPRESENTATIVE.
 6. EXISTING BRIDGE FOOTINGS, COLUMNS, RETAINING WALLS AND OVERHEAD ELEMENTS ARE TO REMAIN. CONTRACTOR TO USE THE UTMOST CARE AROUND THEM AND NOT UNDERMINE ANY PART. IF THE CONTRACTOR HITS/DAMAGES ANY BRIDGE PARTS, THEY NEED TO CONTACT THE OWNER'S REPRESENTATIVE IMMEDIATELY. ANY REPAIRS AS A RESULT OF CONTRACTOR ACTIVITY IS THE RESPONSIBILITY OF THE CONTRACTOR.
 7. EXISTING CURBS AND SIDE WALKS TO REMAIN UNLESS SPECIFICALLY SHOWN TO BE REMOVED. CONTRACTOR TO USE THE UTMOST CARE AROUND THEM AND NOT UNDERMINE ANY PART. IF THE CONTRACTOR HITS/DAMAGES ANY BRIDGE PARTS, THEY NEED TO CONTACT THE OWNER'S REPRESENTATIVE IMMEDIATELY. ANY REPAIRS AS A RESULT OF CONTRACTOR ACTIVITY IS THE RESPONSIBILITY OF THE CONTRACTOR.

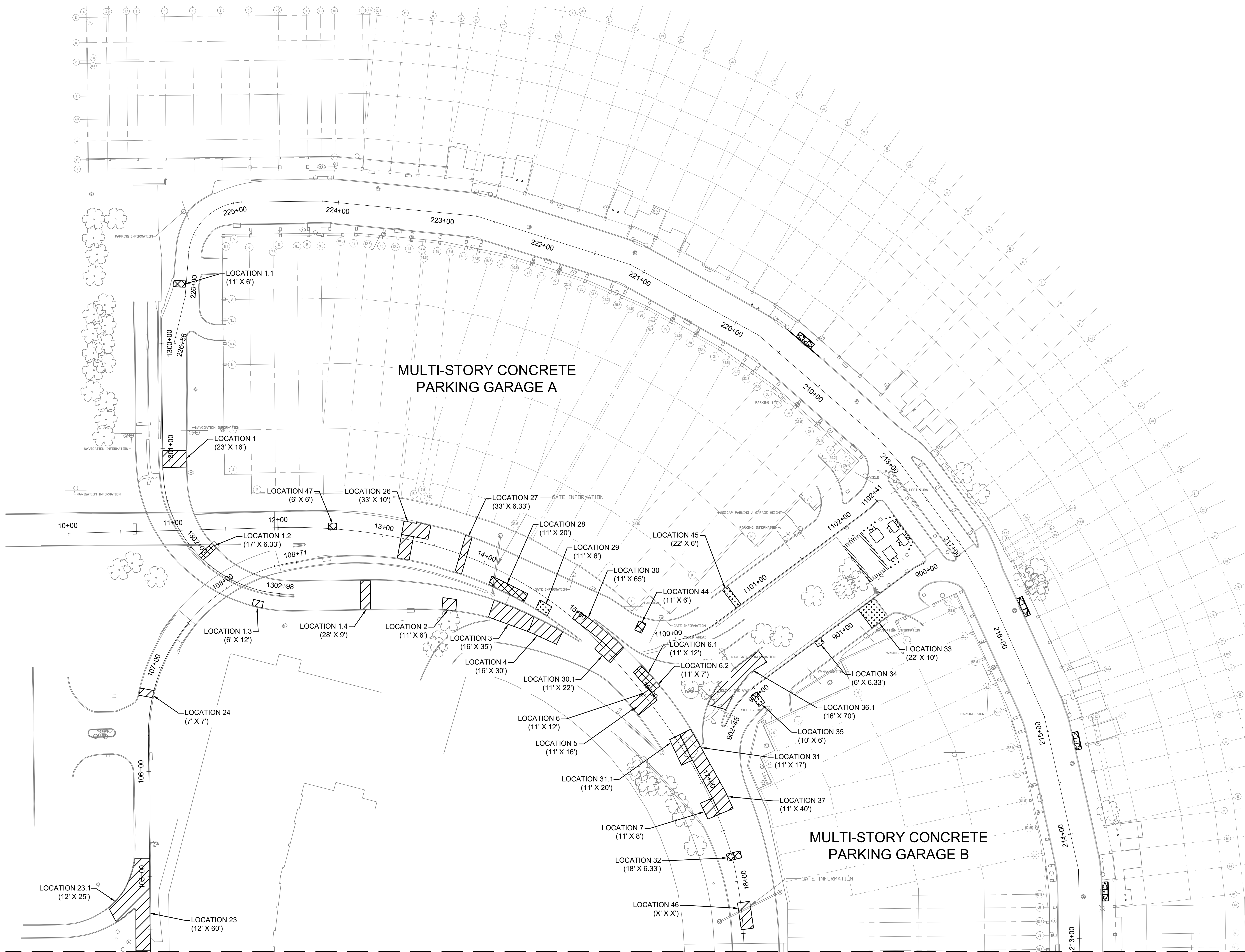

MATCHLINE - SEE SHEET CP110-900R

KEY PLAN

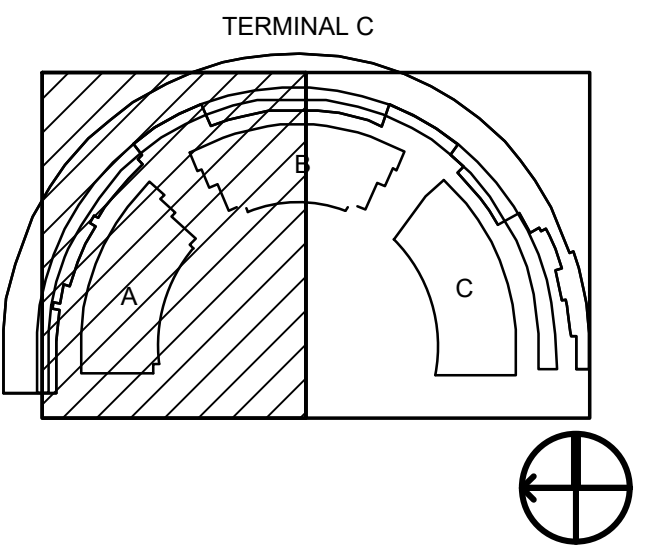

BORDER RELEASE DATE: October 16, 2021
 01/20/2021 14:50:09 LT:\J0919100\CP109-900R.dwg
 C:\Users\j0919100\Documents\CP109-900R.dwg



2330 N INTERNATIONAL PARKWAY
DFW AIRPORT, TX 75261

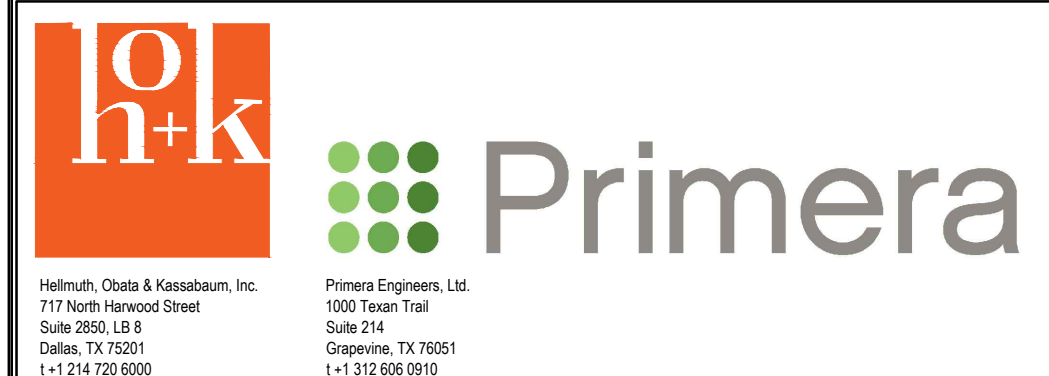

DRAWN BY: JB
 APPROVED BY: JMA
 ISSUE DATE: 2022-07-28
NOT FOR BID OR CONSTRUCTION

NO.	DATE	DESCRIPTION
2022-01-06	30% DESIGN	
2022-05-01	100% DESIGN	
2022-07-28	100% DESIGN FOR PERMIT (DPP)	

TERMINAL C GARAGE & ROADWAYS
PAVEMENT REPAIR PLAN

PROJECT NUMBER: TFD-007

PERMIT NUMBER: B22-0023

SHEET NUMBER
CP109-900R

SCALE(S) AS NOTED ON THIS SHEET ARE BASED ON A FULL SIZE 30 X 42 SHEET.

MATCHLINE - SEE SHEET CP109-900R

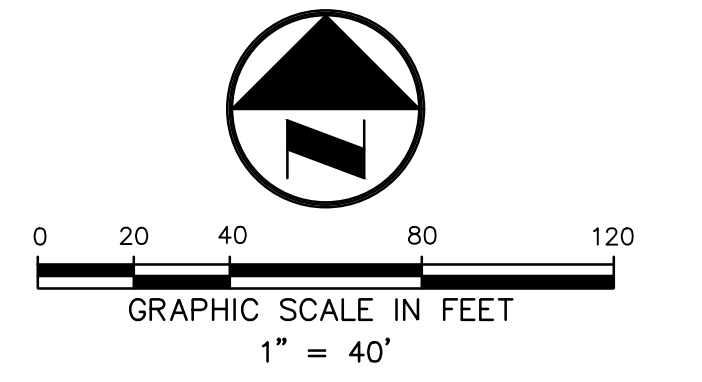

LEGEND

- LEVEL A = WORK TO BE COMPLETED DURING PHASE 1
- LEVEL B = WORK TO BE COMPLETED DURING PHASE 1
- LEVEL C = WORK TO BE COMPLETED DURING PHASE 3

NOTES:

1. FIELD INSPECTION REQUIRED TO DETERMINE EXACT SIZE AND LOCATION OF REPAIRS.
2. SEE TXDOT STANDARD REPCP-14 ON SHEET CP502-900R FOR ADDITIONAL DETAIL.
3. SEE LOWER ROADWAY PHASING SEQUENCING NOTES ON SHEET CT100-900R FOR ADDITIONAL DETAIL.
4. SEE LOWER LEVEL DEMOLITION PLANS ON SHEETS CD101-900R & CD102-900R FOR ADDITIONAL DETAIL.
5. PAVEMENT REPAIR HATCHING ARE APPROXIMATE. DIMENSIONS PROVIDED ARE BASED ON SITE VISIT CONDUCTED IN 2021. PRIOR TO START OF WORK, CONTRACTOR IS TO PERFORM INSPECTION TO CONFIRM LIMITS OF PAVEMENT DETERIORATION EXCEED THE ESTIMATED QUANTITY SHOWN IN THE DRAWINGS. THE CONTRACTOR IS TO CONTACT OWNER'S REPRESENTATIVE.
6. EXISTING BRIDGE FOOTINGS, COLUMNS, RETAINING WALLS AND OVERHEAD ELEMENTS ARE TO REMAIN. CONTRACTOR TO USE THE UTMOST CARE AROUND THEM AND NOT UNDERMINE ANY PART. IF THE CONTRACTOR HITS/DAMAGES ANY BRIDGE PARTS, THEY NEED TO CONTACT THE OWNER'S REPRESENTATIVE IMMEDIATELY. ANY REPAIRS AS A RESULT OF CONTRACTOR ACTIVITY IS THE RESPONSIBILITY OF THE CONTRACTOR.
7. EXISTING CURBS AND SIDE WALKS TO REMAIN UNLESS SPECIFICALLY SHOWN TO BE REMOVED. CONTRACTOR TO USE THE UTMOST CARE AROUND THEM AND NOT UNDERMINE ANY PART. IF THE CONTRACTOR HITS/DAMAGES ANY BRIDGE PARTS, THEY NEED TO CONTACT THE OWNER'S REPRESENTATIVE IMMEDIATELY. ANY REPAIRS AS A RESULT OF CONTRACTOR ACTIVITY IS THE RESPONSIBILITY OF THE CONTRACTOR.

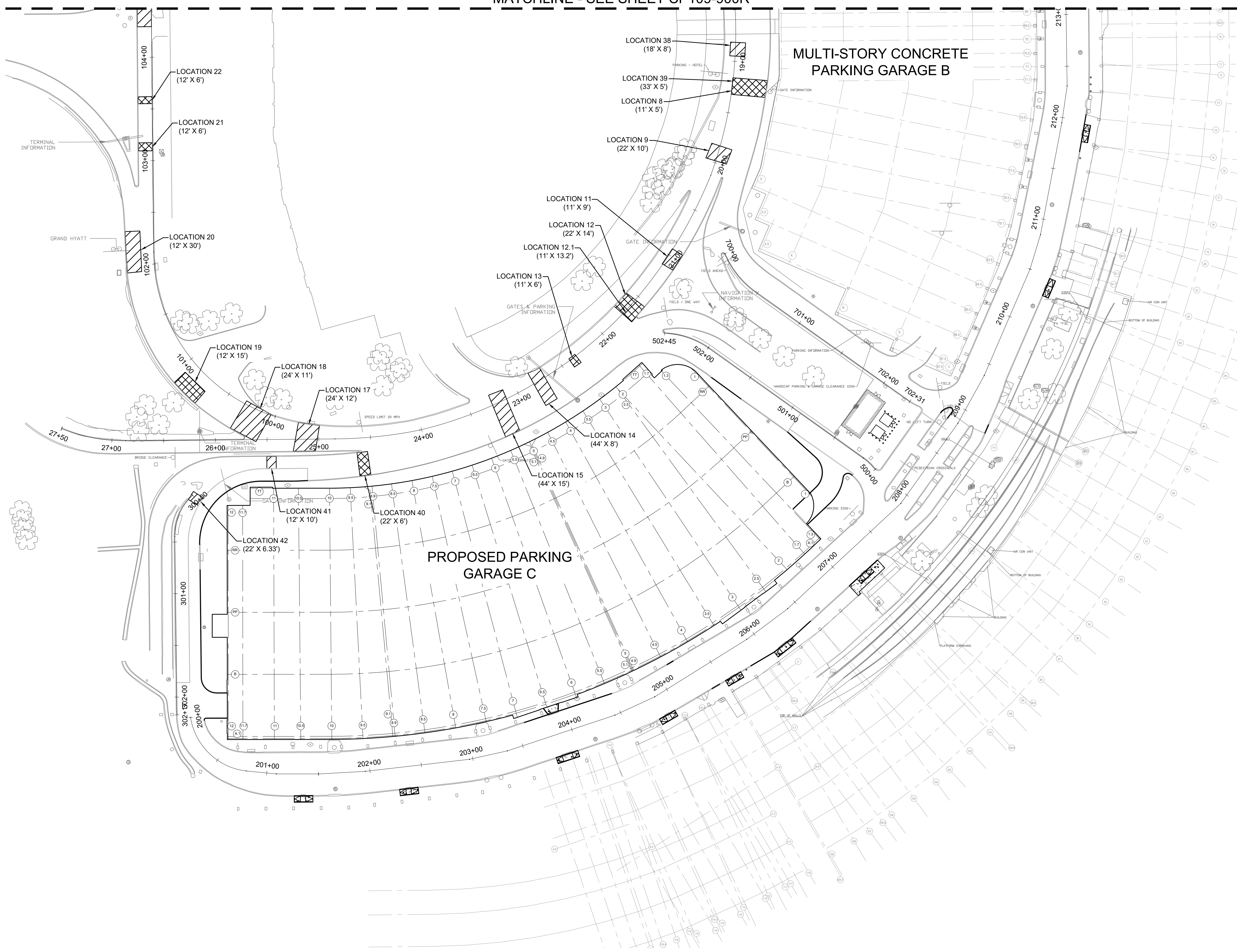

KEY PLAN

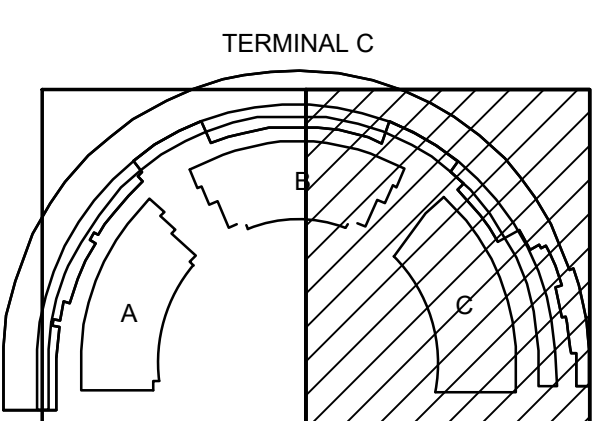

BORDER RELEASE DATE: October 16, 2021
 01/20/2021 10:50:09 AM C:\Users\jmc2020\OneDrive\Documents\CP110-900R-PavementRepair.dwg
 C:\Users\jmc2020\OneDrive\Documents\CP110-900R-PavementRepair.dwg

DALLAS
FORT WORTH
INTERNATIONAL
AIRPORT

2330 N INTERNATIONAL PARKWAY
DFW AIRPORT, TX 75261



Primera

Primera Engineers, LLC
 300 West Loop
 Suite 211
 Irving, TX 75039
 (+1) 214 720 8900

DRAWN BY: JB
 APPROVED BY: JMA
 ISSUE DATE: 2022-07-28

NOT FOR BID OR CONSTRUCTION

NO.	DATE	DESCRIPTION
001	2022-01-06	30% DESIGN
002	2022-03-01	100% DESIGN
003	2022-07-28	100% REVISED FOR PERMIT (RFP)

PROJECT NUMBER: TFD-007

TERMINAL C GARAGE & ROADWAYS
PAVEMENT REPAIR PLAN

PERMIT NUMBER: B22-0023

SHEET NUMBER
CP110-900R

SCALE(S) AS NOTED ON THIS SHEET ARE BASED ON A FULL SIZE 30 X 42 SHEET.

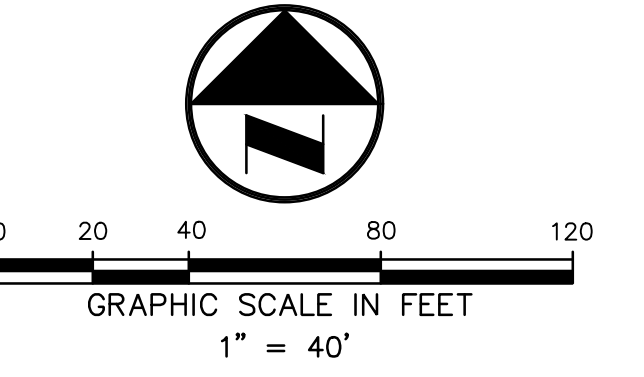

EXISTING LEGEND

- CRIADO CONTROL POINT
- IRON ROD FOUND
- BOLLARD
- GAS METER
- TRAFFIC SIGNAL LIGHT POLE
- TRAFFIC SIGNAL PULL BOX
- TRAFFIC SIGNAL CONTROL BOX
- TELECOM SERVICE BOX
- TELECOM PEDESTAL
- CATV PEDESTAL
- CATV JUNCTION BOX
- CATV APPURTENANCE
- LIGHT POLE
- CATHODIC PROTECTION
- FLAG POLE
- GENERIC MANHOLE
- POWER POLE
- GUYWIRE
- ELECTRIC MANHOLE
- ELECTRIC PULL BOX
- ELECTRIC METER
- ELECTRIC BOX
- ELECTRIC RISER
- GROUND LIGHT SIGN
- GAS PUMP
- FUEL TANK VENT
- TREE
- BUSH
- WASTE WATER CLEANOUT
- WASTE WATER MANHOLE
- STORM DRAIN MANHOLE
- WATER VALVE
- IRRIGATION CONTROL VALVE
- SPRINKLER HEAD
- SPIGOT
- FIRE HYDRANT
- WATER METER
- OVERHEAD UTILITY
- OVERHEAD ELECTRIC

PROPOSED LEGEND

- ① CROSSWALK STRIPING, 2' BAR, 3.25' GAP (WIDTH PER PLAN, WHITE)
- ② SOLID LINE (4" WIDE, WHITE)
- ③ SOLID LINE (12" WIDE, WHITE)
- ④ 10' DASH, 30' SKIP (4" WIDE, WHITE)
- ⑤ YIELD LINE (SEE DETAIL 8, SHEET CP501-900R, WHITE)

PAVEMENT MARKING NOTES

1. ALL PAVEMENT MARKINGS SHALL BE IN ACCORDANCE WITH THE MANUAL ON UNIFORM TRAFFIC CONTROL DEVICES (MUTCD) AND THE TEXAS DEPARTMENT OF TRANSPORTATION (TXDOT) STANDARDS. ALL PAVEMENT MARKINGS TO BE IN ACCORDANCE WITH TXDOT SPEC 666, TYPE 1.
2. COLOR, WIDTH, STYLE, AND SIZE OF ALL MARKINGS SHALL BE IN ACCORDANCE WITH THE MUTCD AND LOCAL CODE.
3. WHERE NEW LANE MARKINGS ARE INSTALLED ADJACENT TO EXISTING LANE MARKINGS, CONTRACTOR SHALL ALIGN SKIPS AND DASHES WITH EXISTING LANE MARKINGS.
4. CONTRACTOR TO COMPLETE PAVEMENT MARKINGS NECESSARY TO REOPEN PHASE TO PUBLIC AT END OF EACH PHASE. SOME MARKINGS MAY BE REQUIRED TO BE RENEWED AT POINTS BETWEEN THE PHASES. COORDINATE WORK WITH OWNER'S REPRESENTATIVE

KEY PLAN

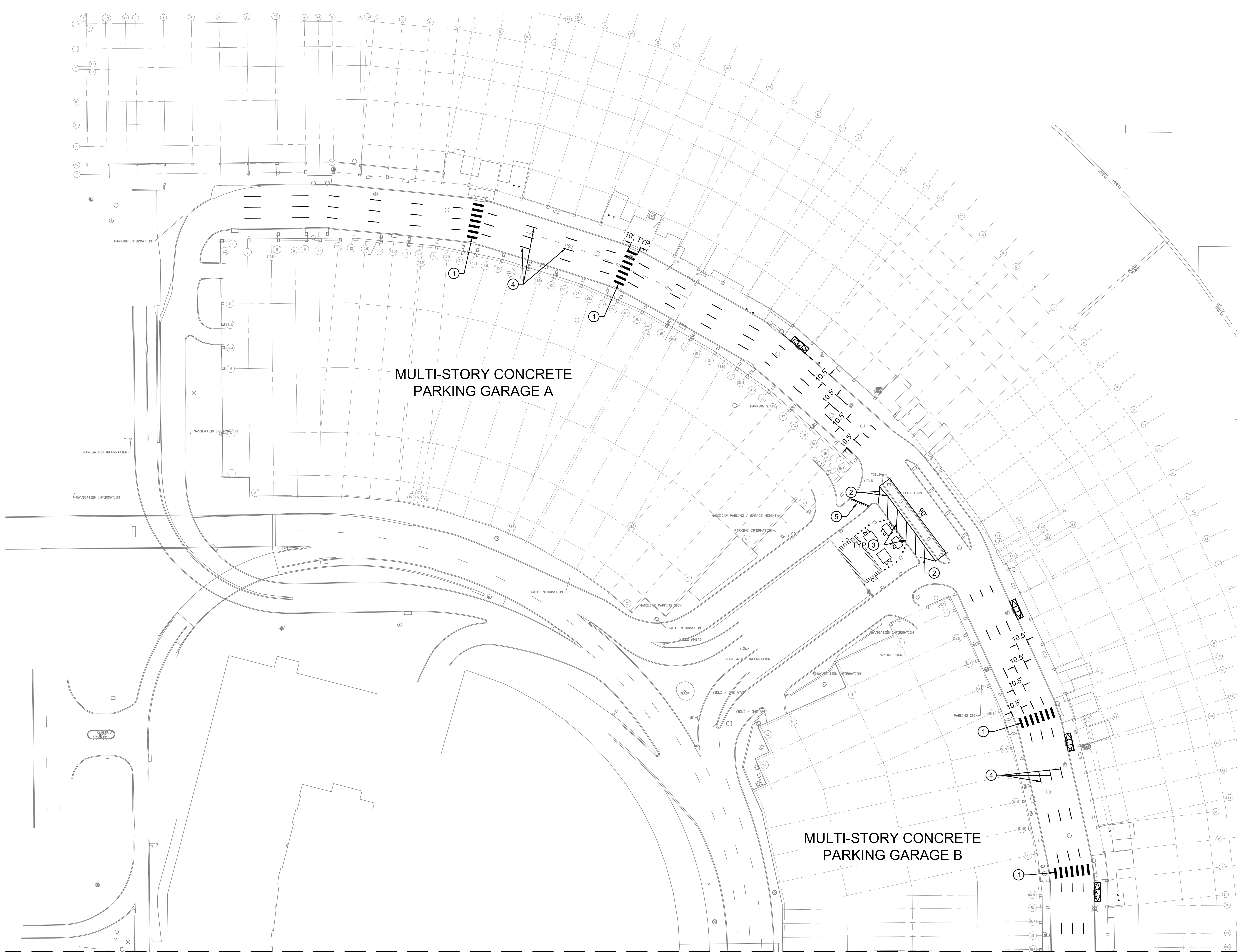
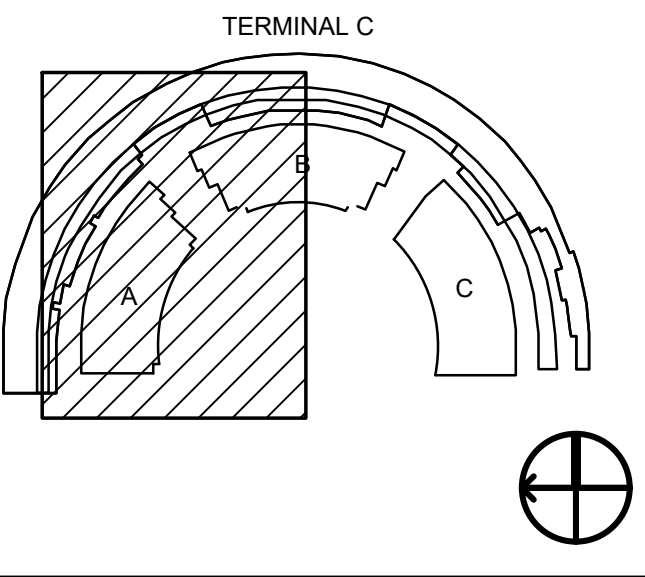

MATCHLINE - SEE SHEET CP112-900R

BORDER RELEASE DATE: October 16, 2021
 01/20/2021 10:09:09 AM
 C:\Users\h3c2c3\OneDrive\Documents\CP111-900R.dwg



DALLAS
 FORT WORTH
 INTERNATIONAL
 AIRPORT
 2330 N INTERNATIONAL PARKWAY
 DFW AIRPORT, TX 75261

Primera
 Engineers, Inc.
 300 West 7th
 Suite 211
 Dallas, TX 75201
 (+1) 214 720 8000

DRAWN BY: SJP
 APPROVED BY: JMA
 ISSUE DATE: 2022-07-28
NOT FOR BID OR CONSTRUCTION

NO.	DATE	DESCRIPTION
2022-01-06	30% DESIGN	
2022-03-01	100% DESIGN	
2022-02-28	100% DESIGN FOR PERMIT (D/P)	

TERMINAL C GARAGE & ROADWAYS
PAVEMENT MARKING PLAN (LOWER ROADWAY)
 PROJECT NUMBER: TFD-007
 PERMIT NUMBER: B22-0023

SHEET NUMBER
CP111-900R

SCALE(S) AS NOTED ON THIS SHEET ARE BASED ON A FULL SIZE 30 X 42 SHEET.

MATCHLINE - SEE SHEET CP111-900R

MULTI-STORY CONCRETE
PARKING GARAGE B

PROPOSED PARKING
GARAGE C

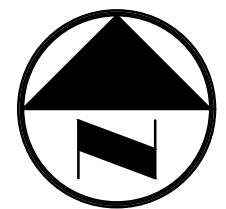

0 20 40 80 120
GRAPHIC SCALE IN FEET
1" = 40'

EXISTING LEGEND

- CRIADO CONTROL POINT
- IRON ROD FOUND
- BOLLARD
- GAS METER
- TRAFFIC SIGNAL LIGHT POLE
- TRAFFIC SIGNAL PULL BOX
- TRAFFIC SIGNAL CONTROL BOX
- TELECOM SERVICE BOX
- TELECOM PEDESTAL
- CATV PEDESTAL
- CATV JUNCTION BOX
- CATV APPURTENANCE
- CATHODIC PROTECTION
- FLAG POLE
- GENERIC MANHOLE
- POWER POLE
- GUYWIRE
- ELECTRIC MANHOLE
- ELECTRIC PULL BOX
- ELECTRIC METER
- ELECTRIC BOX
- ELECTRIC RISER
- GROUND LIGHT SIGN
- GAS PUMP
- FUEL TANK VENT TREE
- BUSH
- WASTE WATER CLEANOUT
- WASTE WATER MANHOLE
- STORM DRAIN MANHOLE
- WATER VALVE
- IRRIGATION CONTROL VALVE
- SPRINKLER HEAD
- SPIGOT
- FIRE HYDRANT
- WATER METER
- OVERHEAD UTILITY
- OVERHEAD ELECTRIC

PROPOSED LEGEND

- ① CROSSWALK STRIPING, 2' BAR, 3.25' GAP (WIDTH PER PLAN, WHITE)
- ② SOLID LINE (4" WIDE, WHITE)
- ③ SOLID LINE (12" WIDE, WHITE)
- ④ 10' DASH, 30' SKIP (4" WIDE, WHITE)
- ⑤ YIELD LINE (SEE DETAIL 8, SHEET CP501-900R, WHITE)

PAVEMENT MARKING NOTES

1. ALL PAVEMENT MARKINGS SHALL BE IN ACCORDANCE WITH THE MANUAL ON UNIFORM TRAFFIC CONTROL DEVICES (MUTCD) AND THE TEXAS DEPARTMENT OF TRANSPORTATION (TXDOT) STANDARDS. ALL PAVEMENT MARKINGS TO BE IN ACCORDANCE WITH TXDOT SPEC 666, TYPE 1.
2. COLOR, WIDTH, STYLE, AND SIZE OF ALL MARKINGS SHALL BE IN ACCORDANCE WITH THE MUTCD AND LOCAL CODE.
3. WHERE NEW LANE MARKINGS ARE INSTALLED ADJACENT TO EXISTING LANE MARKINGS, CONTRACTOR SHALL ALIGN SKIPS AND DASHES WITH EXISTING LANE MARKINGS.
4. CONTRACTOR TO COMPLETE PAVEMENT MARKINGS NECESSARY TO REOPEN PHASE TO PUBLIC AT END OF EACH PHASE. SOME MARKINGS MAY BE REQUIRED TO BE RENEWED AT POINTS BETWEEN THE PHASES. COORDINATE WORK WITH OWNER'S REPRESENTATIVE

KEY PLAN

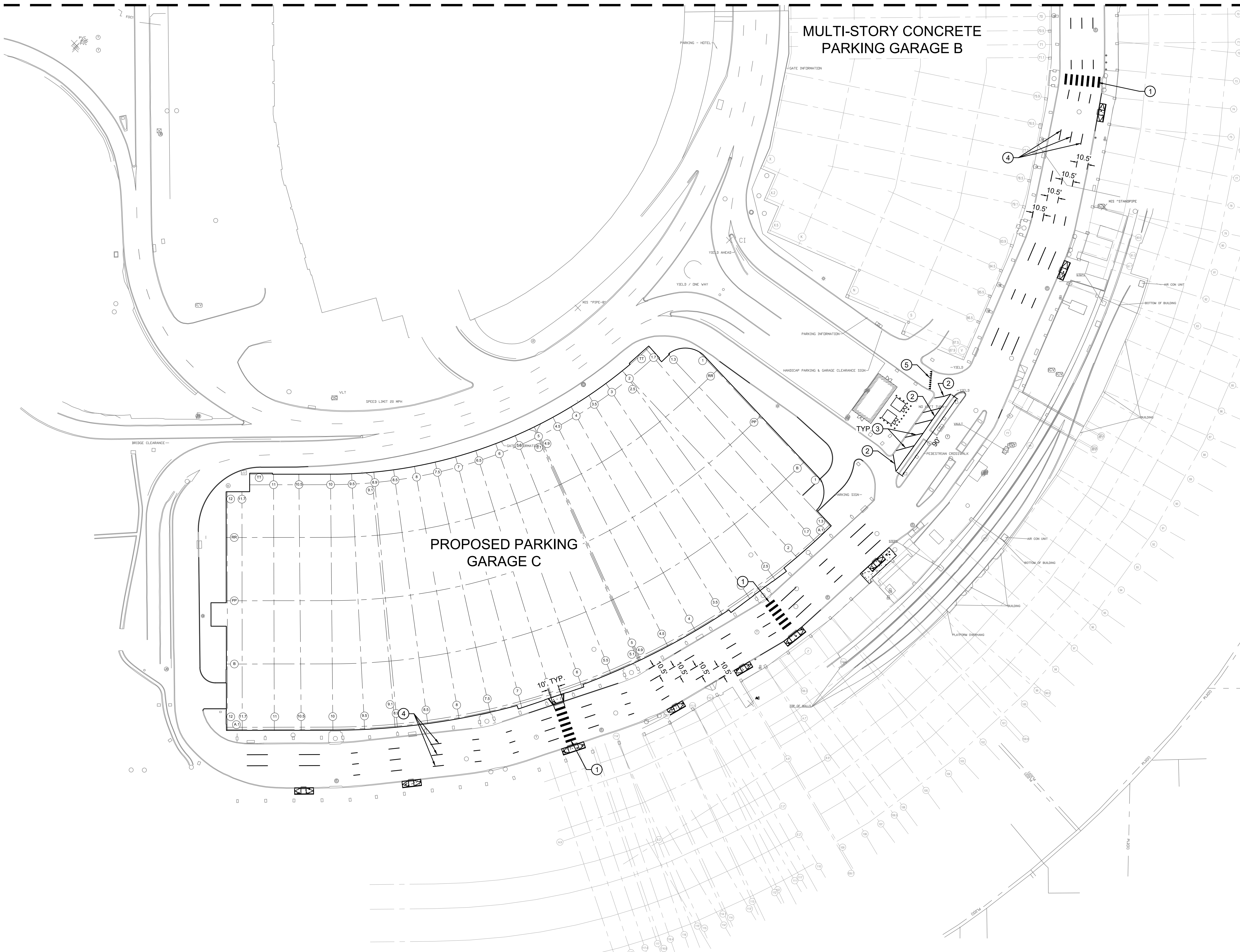
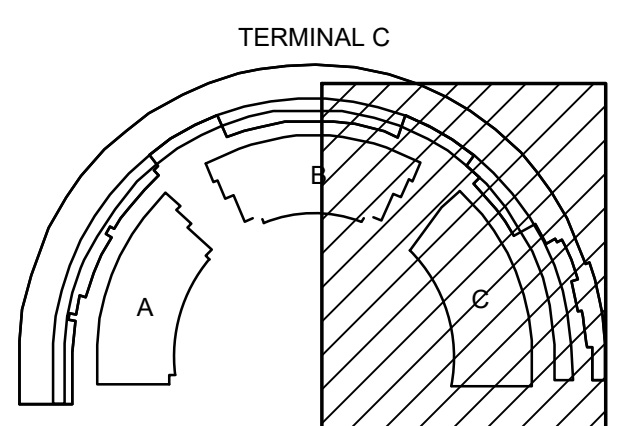

BORDER RELEASE DATE: October 16, 2021
01/20/2021 10:59:09 AM
C:\Users\jmc2020\OneDrive\Documents\CP112-900R\CP112-900R.dwg



DALLAS
FORT WORTH
INTERNATIONAL
AIRPORT

2330 N INTERNATIONAL PARKWAY
DFW AIRPORT, TX 75261



h+k **Primera**

Heidi-John, Chad & Kaseyann, Inc.
777 South Meadows Drive
Suite 200, LB #
Dallas, TX 75201
+1 214 720 8000

Primera Engineers, Ltd.
300 West 7th
Suite 211
Ovington, TX 76051
+1 312 606 0910

DRAWN BY: SJP
APPROVED BY: JMA
ISSUE DATE: 2022-07-28
NOT FOR BID OR CONSTRUCTION

NO.	DATE	DESCRIPTION
1	2022-01-06	30% DESIGN
2	2022-03-01	100% DESIGN
3	2022-07-28	100% REVISED FOR PERMIT (RFP)

TERMINAL C GARAGE & ROADWAYS
PAVEMENT MARKING PLAN (LOWER ROADWAY)

PROJECT NUMBER: TFD-007

PERMIT NUMBER: B22-0023

SHEET NUMBER
CP112-900R

SCALE(S) AS NOTED ON THIS SHEET ARE BASED ON A FULL SIZE 30 X 42 SHEET.

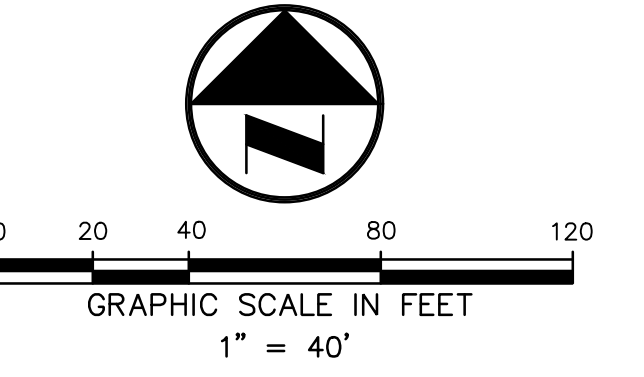

EXISTING LEGEND

- CRIADO CONTROL POINT
- IRON ROD FOUND
- BOLLARD
- GAS METER
- TRAFFIC SIGNAL LIGHT POLE
- TRAFFIC SIGNAL PULL BOX
- TRAFFIC SIGNAL CONTROL BOX
- TELECOM SERVICE BOX
- TELECOM PEDESTAL
- TELECOM MANHOLE
- CATV PEDESTAL
- CATV JUNCTION BOX
- CATV APPURTENANCE
- LIGHT POLE
- CATHODIC PROTECTION
- FLAG POLE
- GENERIC MANHOLE
- POWER POLE
- GUYWIRE
- ELECTRIC MANHOLE
- ELECTRIC PULL BOX
- ELECTRIC METER
- ELECTRIC BOX
- ELECTRIC RISER
- GROUND LIGHT SIGN
- GAS PUMP
- FUEL TANK VENT
- TREE
- BUSH
- WASTE WATER CLEANOUT
- WASTE WATER MANHOLE
- STORM DRAIN MANHOLE
- WATER VALVE
- IRRIGATION CONTROL VALVE
- SPRINKLER HEAD
- SPIGOT
- FIRE HYDRANT
- WATER METER
- OVERHEAD UTILITY
- OVERHEAD ELECTRIC

PROPOSED LEGEND

- ① CROSSWALK STRIPING, 2' BAR, 3.25' GAP (WIDTH PER PLAN, WHITE)
- ② SOLID LINE (4" WIDE, WHITE)
- ③ SOLID LINE (12" WIDE, WHITE)
- ④ 10' DASH, 30' SKIP (4" WIDE, WHITE)
- ⑤ YIELD LINE (SEE DETAIL 8, SHEET CP501-900R, WHITE)

PAVEMENT MARKING NOTES

1. ALL PAVEMENT MARKINGS SHALL BE IN ACCORDANCE WITH THE MANUAL ON UNIFORM TRAFFIC CONTROL DEVICES (MUTCD) AND THE TEXAS DEPARTMENT OF TRANSPORTATION (TXDOT) STANDARDS. ALL PAVEMENT MARKINGS TO BE IN ACCORDANCE WITH TXDOT SPEC 666, TYPE 1.
2. COLOR, WIDTH, STYLE, AND SIZE OF ALL MARKINGS SHALL BE IN ACCORDANCE WITH THE MUTCD AND LOCAL CODE.
3. WHERE NEW LANE MARKINGS ARE INSTALLED ADJACENT TO EXISTING LANE MARKINGS, CONTRACTOR SHALL ALIGN SKIPS AND DASHES WITH EXISTING LANE MARKINGS.
4. EXISTING PAVEMENT MARKINGS NEED TO BE REMOVED AND TEMPORARY PAVEMENT MARKINGS WILL BE REQUIRED TO REOPEN EACH PHASE TO PUBLIC AT END OF THAT PHASE. SOME MARKINGS MAY BE REQUIRED TO BE RENEWED AT POINTS BETWEEN THE PHASES. COORDINATE WORK WITH OWNER'S REPRESENTATIVE.
5. DURING PHASE 3 ALL TRAFFIC SURFACE COATING WILL BE REMOVED. BRIDGE DECK REPAIRS WILL OCCUR AND NEW TRAFFIC COATINGS TO BE APPLIED. PROVIDE TEMPORARY MARKINGS AFTER DECK COATING IS REMOVED AND PERMANENT MARKING AFTER COATING IS PLACED NEAR END OF PHASE 3.

KEY PLAN

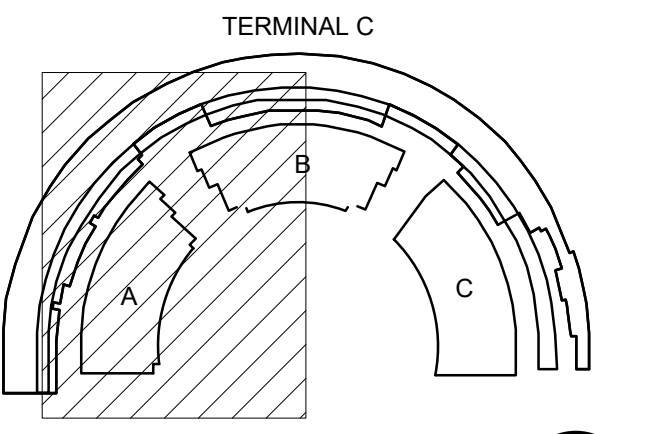

MATCHLINE - SEE SHEET CP114-900R

MULTI-STORY CONCRETE PARKING GARAGE A

MULTI-STORY CONCRETE PARKING GARAGE B

BORDER RELEASE DATE: October 16, 2021
 01/22/2021 10:59:09 AM
 C:\Users\jmc2020\OneDrive\Documents\HOK\DAL\DFW\Int'l Airport - CTA Expansion Program\Project Files\01_CTA - Terminal C Garages and Roadways\CE\01 - CAD\Sheets\800\802_DFW-TC-CP114-900R_Pavement.dwg



2330 N INTERNATIONAL PARKWAY
 DFW AIRPORT, TX 75261



DRAWN BY: SJP
 APPROVED BY: JMA
 ISSUE DATE: 2022-07-28
NOT FOR BID OR CONSTRUCTION

NO.	DATE	DESCRIPTION
2022-01-06	30% DESIGN	
2022-03-01	100% DESIGN	
2022-07-28	100% REVISED FOR PERMIT (RFP)	

TERMINAL C GARAGE & ROADWAYS
PAVEMENT MARKING PLAN (UPPER ROADWAY)
 PROJECT NUMBER: TFD-007
 PERMIT NUMBER: B22-0023

SHEET NUMBER
CP113-900R

SCALE(S) AS NOTED ON THIS SHEET ARE BASED ON A FULL SIZE 30 X 42 SHEET.

MATCHLINE - SEE SHEET CP113-900R

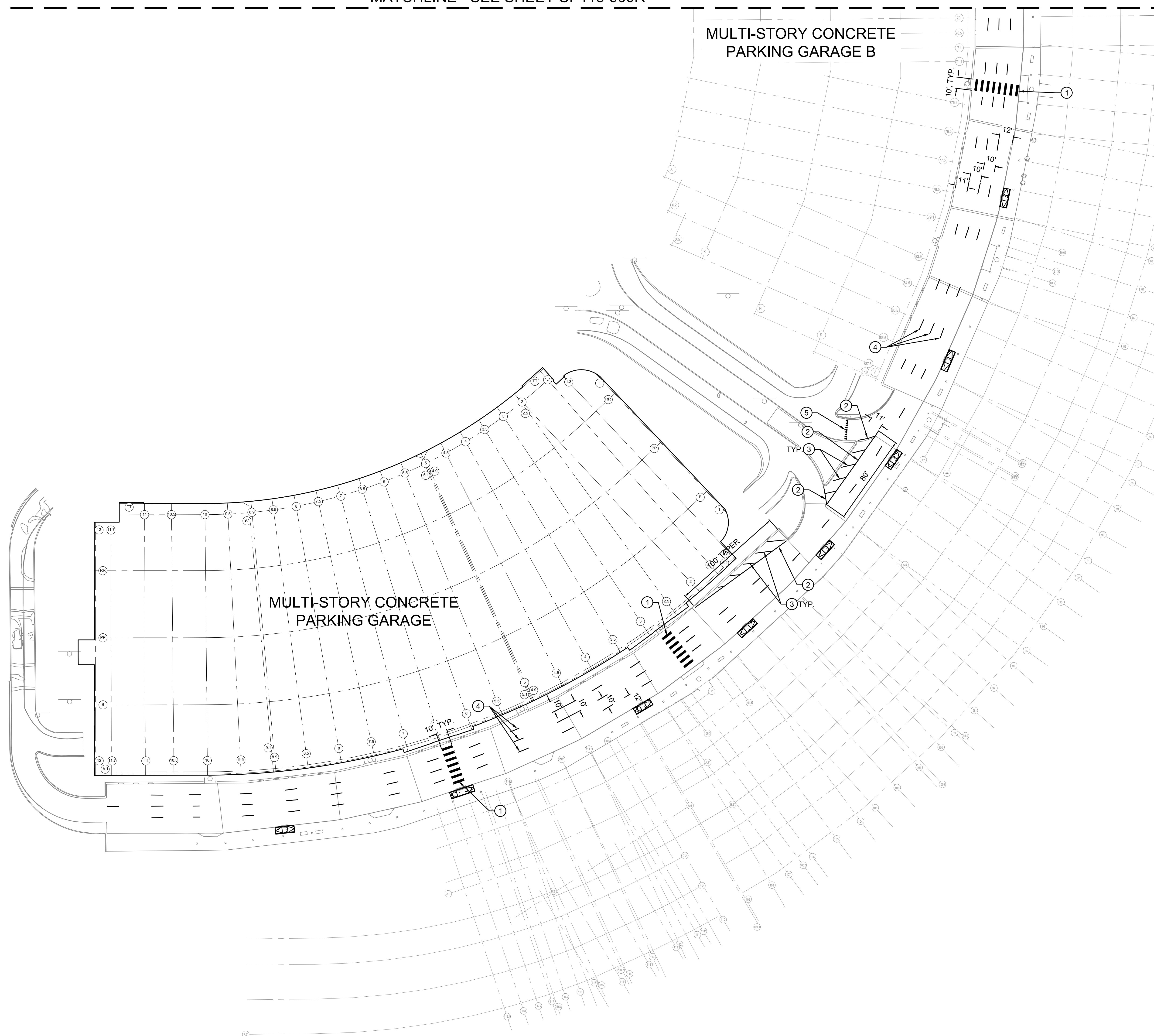
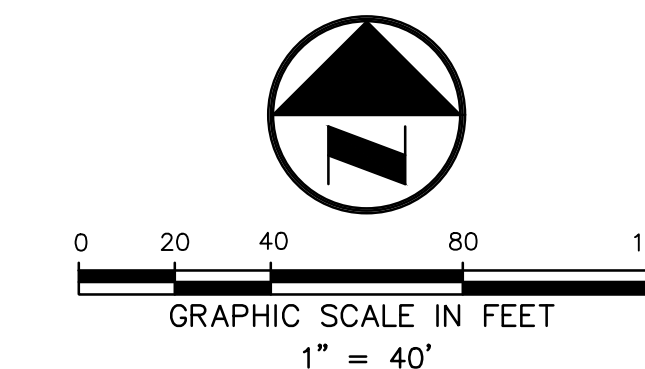

EXISTING LEGEND

- CRIADO CONTROL POINT
- IRON ROD FOUND
- GAS METER
- TRAFFIC SIGNAL LIGHT POLE
- TRAFFIC SIGNAL PULL BOX
- TRAFFIC SIGNAL CONTROL BOX
- TELECOM SERVICE BOX
- TELECOM PEDESTAL
- CATV PEDESTAL
- CATV JUNCTION BOX
- CATV APPURTENANCE
- LIGHT POLE
- CATHODIC PROTECTION
- FLAG POLE
- GENERIC MANHOLE
- POWER POLE
- GUYWIRE
- ELECTRIC MANHOLE
- ELECTRIC PULL BOX
- ELECTRIC METER
- ELECTRIC BOX
- ELECTRIC RISER
- GROUND LIGHT SIGN
- GAS PUMP
- FUEL TANK VENT
- TREE
- BUSH
- WASTE WATER CLEANOUT
- WASTE WATER MANHOLE
- STORM DRAIN MANHOLE
- WATER VALVE
- IRRIGATION CONTROL VALVE
- SPRINKLER HEAD
- SPIGOT
- FIRE HYDRANT
- WATER METER
- OVERHEAD UTILITY
- OVERHEAD ELECTRIC

PROPOSED LEGEND

- ① CROSSWALK STRIPING, 2' BAR, 3.25' GAP (WIDTH PER PLAN, WHITE)
- ② SOLID LINE (4" WIDE, WHITE)
- ③ SOLID LINE (12" WIDE, WHITE)
- ④ 10' DASH, 30' SKIP (4" WIDE, WHITE)
- ⑤ YIELD LINE (SEE DETAIL 8, SHEET CP501-900R, WHITE)

PAVEMENT MARKING NOTES

1. ALL PAVEMENT MARKINGS SHALL BE IN ACCORDANCE WITH THE MANUAL ON UNIFORM TRAFFIC CONTROL DEVICES (MUTCD) AND THE TEXAS DEPARTMENT OF TRANSPORTATION (TXDOT) STANDARDS. ALL PAVEMENT MARKINGS TO BE IN ACCORDANCE WITH TXDOT SPEC 666, TYPE 1.
2. COLOR, WIDTH, STYLE, AND SIZE OF ALL MARKINGS SHALL BE IN ACCORDANCE WITH THE MUTCD AND LOCAL CODE.
3. WHERE NEW LANE MARKINGS ARE INSTALLED ADJACENT TO EXISTING LANE MARKINGS, CONTRACTOR SHALL ALIGN SKIPS AND DASHES WITH EXISTING LANE MARKINGS.
4. EXISTING PAVEMENT MARKINGS NEED TO BE REMOVED AND TEMPORARY PAVEMENT MARKINGS WILL BE REQUIRED TO REOPEN EACH PHASE TO PUBLIC AT END OF THAT PHASE. SOME MARKINGS MAY BE REQUIRED TO BE RENEWED AT POINTS BETWEEN THE PHASES. COORDINATE WORK WITH OWNER'S REPRESENTATIVE.
5. DURING PHASE 3 ALL TRAFFIC SURFACE COATING WILL BE REMOVED. BRIDGE DECK REPAIRS WILL OCCUR AND NEW TRAFFIC COATINGS TO BE APPLIED. PROVIDE TEMPORARY MARKINGS AFTER DECK COATING IS REMOVED AND PERMANENT MARKING AFTER COATING IS PLACED NEAR END OF PHASE 3.

KEY PLAN

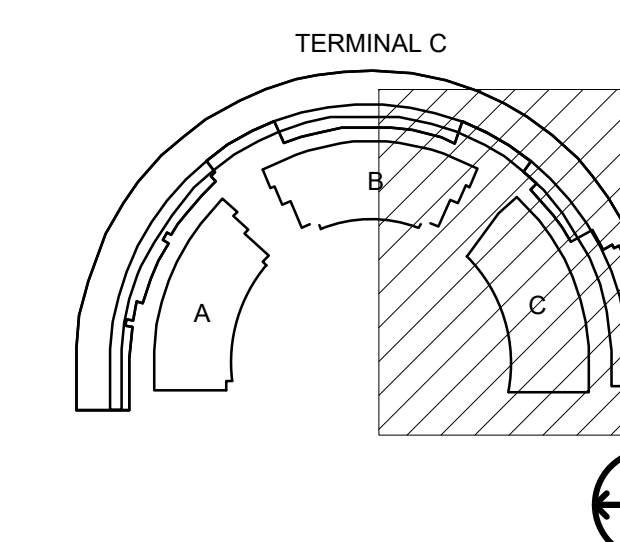

BORDER RELEASE DATE: October 16, 2021
01/20/2021 10:09:09 AM C:\Users\hok\OneDrive\Documents\HOK\DAL\DFW\Int'l Airport - CTA Expansion Program\Project Files\01_CTA - Terminal C Garages and Roadways\CE\01 - CAD\Sheets\800\802_DFW-TC-CP114-900R_Pavement.dwg



DALLAS
FORT WORTH
INTERNATIONAL
AIRPORT



DRAWN BY: SJP
APPROVED BY: JMA
ISSUE DATE: 2022-07-28
NOT FOR BID OR CONSTRUCTION

NO.	DATE	DESCRIPTION
1	2022-01-06	30% DESIGN
2	2022-03-01	100% DESIGN
3	2022-07-28	100% REVISED FOR PERMIT (RFP)

TERMINAL C GARAGE & ROADWAYS
PAVEMENT MARKING PLAN (UPPER ROADWAY)

PROJECT NUMBER: TFD-007

PERMIT NUMBER: B22-0023

SHEET NUMBER
CP114-900R

SCALE(S) AS NOTED ON THIS SHEET ARE BASED ON A FULL SIZE 30 X 42 SHEET.

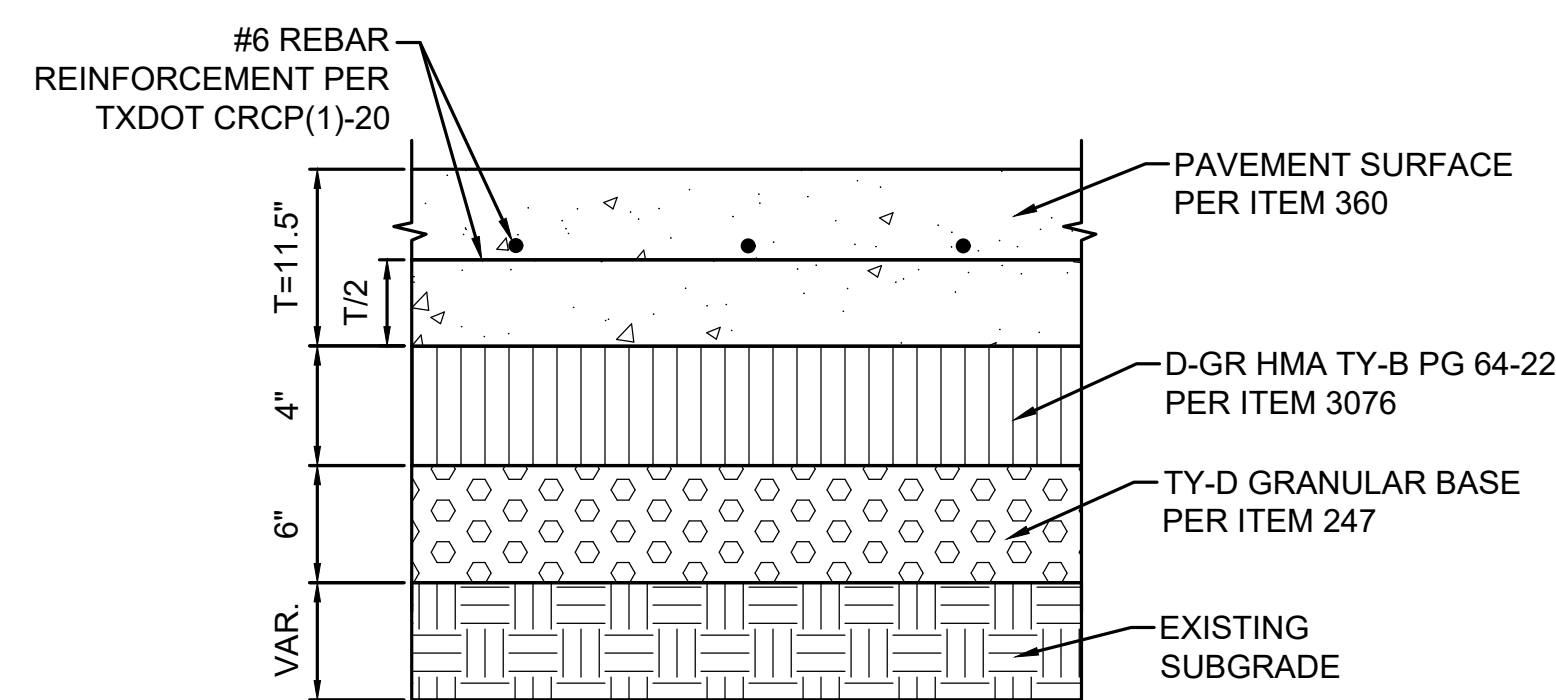

NOTE:
REFER TO GEOTECH REPORT
FOR FURTHER INFORMATION.

1 LOWER ROADWAY PAVEMENT SECTION (RING ROAD)
N.T.S.

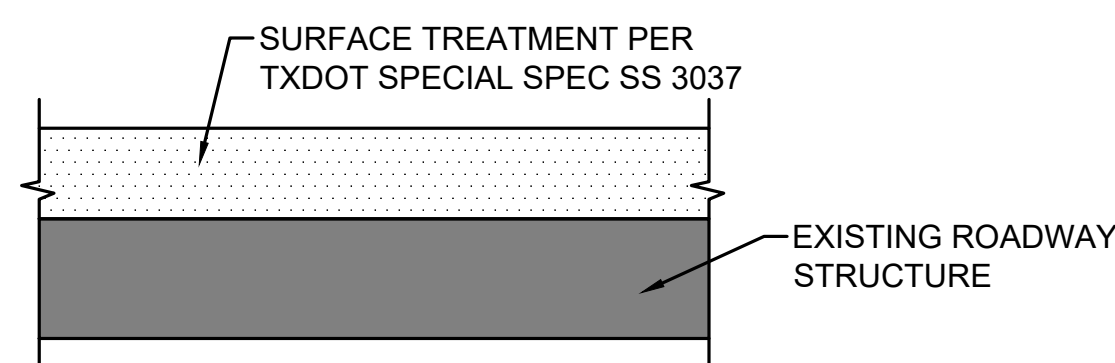

2 UPPER ROADWAY PAVEMENT SECTION
N.T.S.

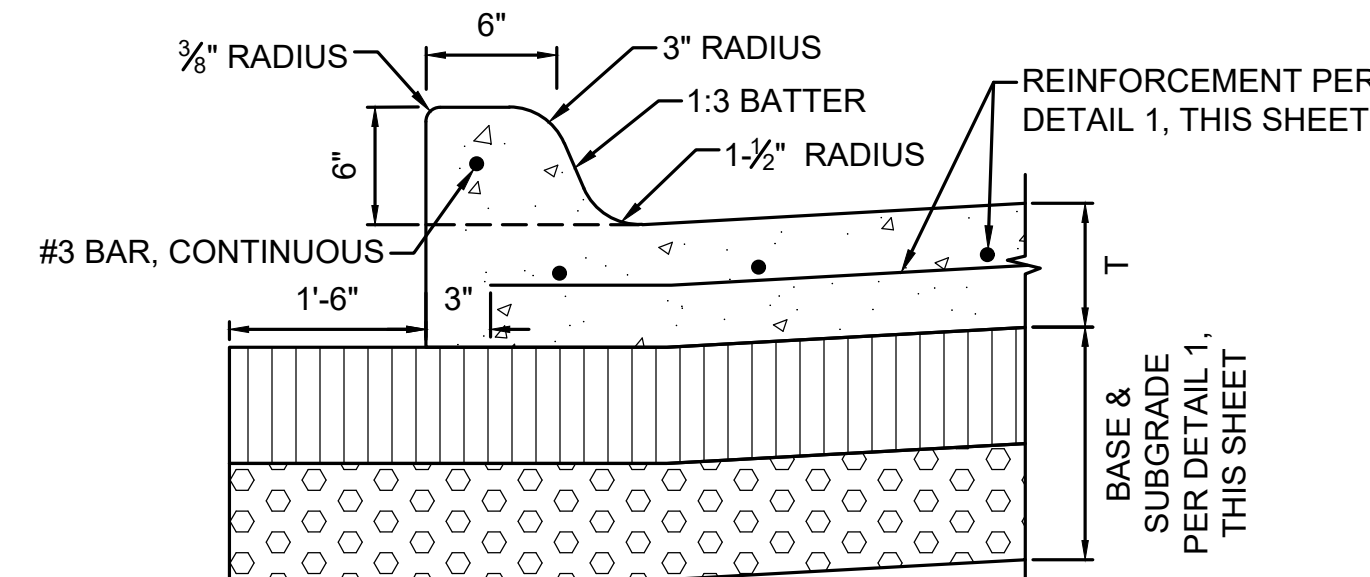

3 INTEGRAL CURB
N.T.S.

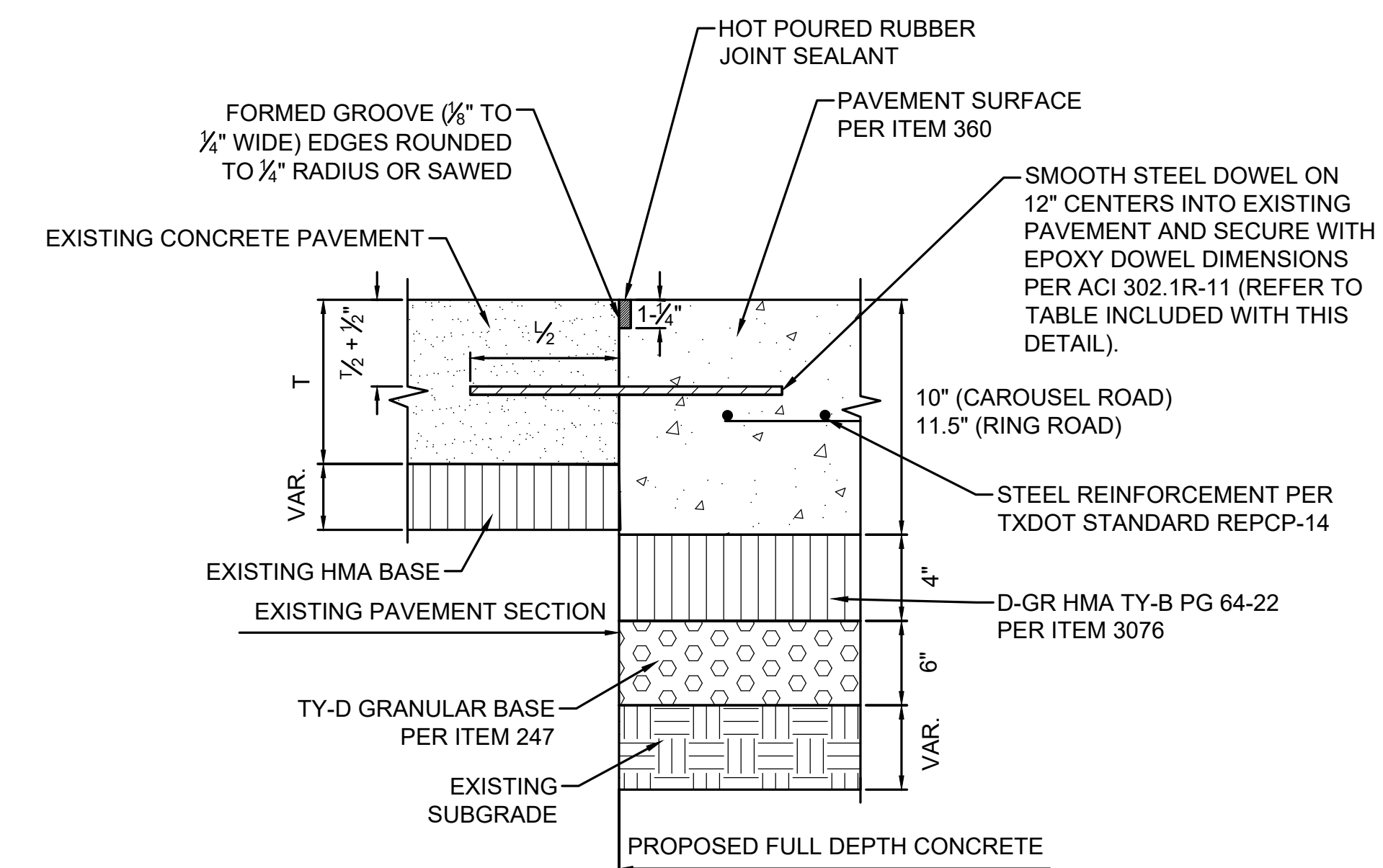

PAVEMENT THICKNESS (T)	DOWEL DIAMETER (D)	DOWEL LENGTH (L)
4"	1/2"	14"
6"	3/4"	16"
8"	1"	18"
10"	1 1/4"	18"

4 NEW CONCRETE PAVEMENT TO EXISTING CONCRETE PAVEMENT
N.T.S.

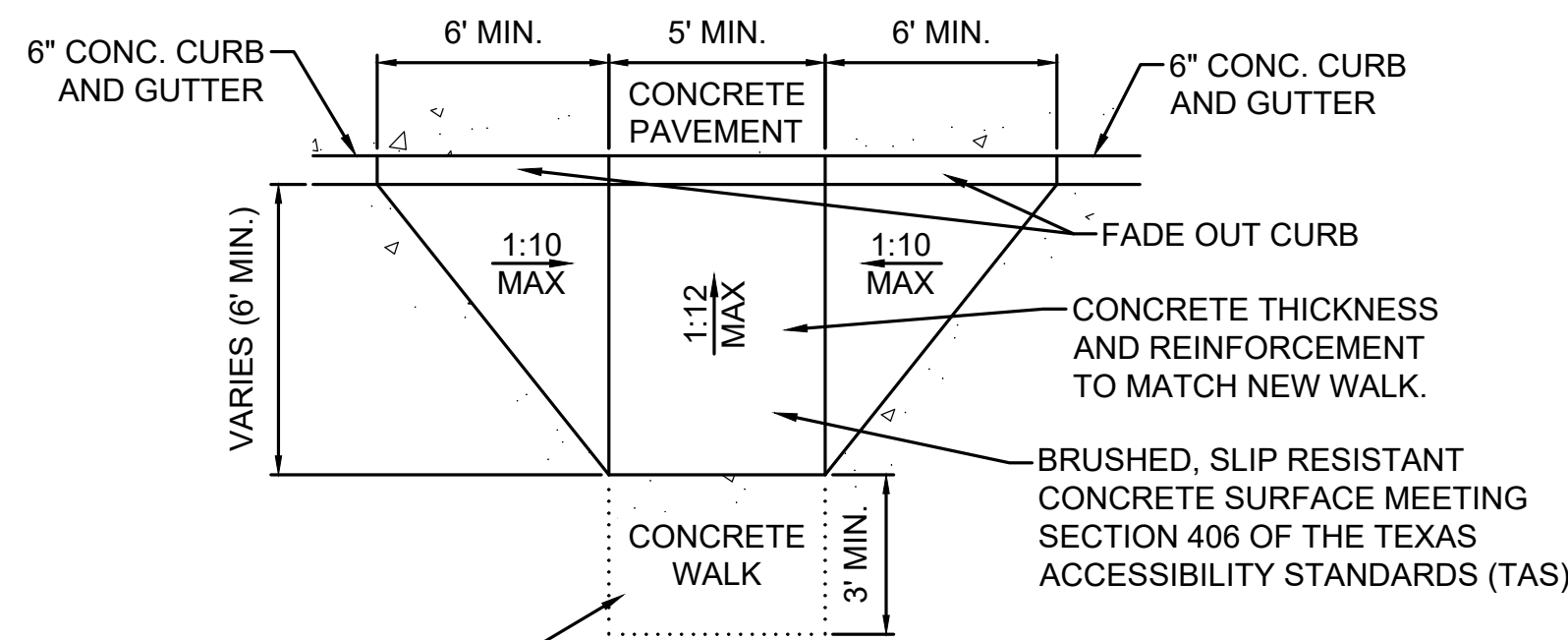

NOTES:
1. MAXIMUM RUNNING SLOPE FOR ALL PATHS IS 5%;
MAXIMUM CROSS SLOPE IS 2%; FOR THE FIRST FIVE
FEET FROM THE DOOR A 2% SLOPE (MAX) MUST BE
MAINTAINED.
2. SIGNAGE AND MARKINGS TO BE IN ACCORDANCE
WITH FEDERAL, STATE, AND LOCAL REGULATIONS.

5 FLARED CURB RAMP
N.T.S.

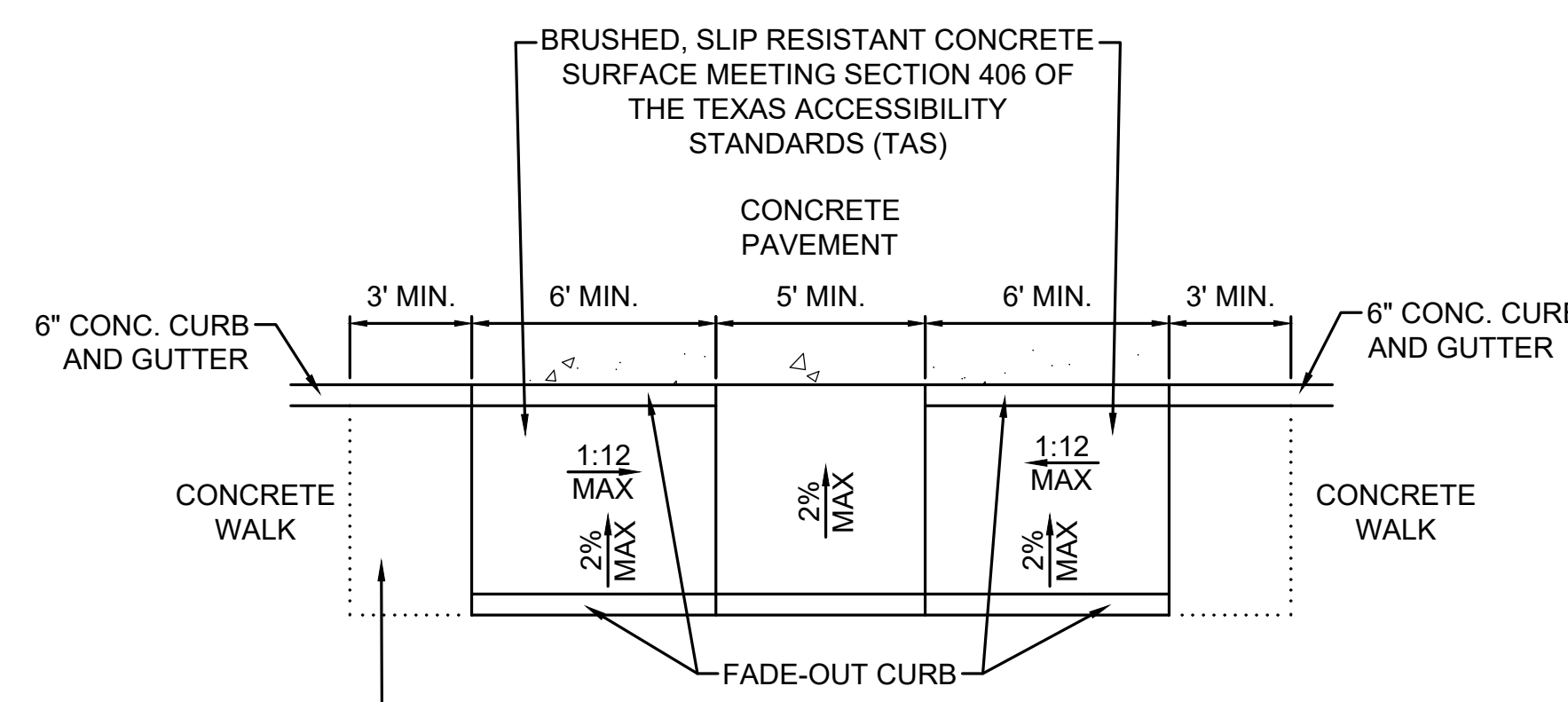

NOTES:
1. MAXIMUM RUNNING SLOPE FOR ALL PATHS IS 5%;
MAXIMUM CROSS SLOPE IS 2%; FOR THE FIRST FIVE
FEET FROM THE DOOR A 2% SLOPE (MAX) MUST BE
MAINTAINED.
2. SIGNAGE AND MARKINGS TO BE IN ACCORDANCE
WITH FEDERAL, STATE, AND LOCAL REGULATIONS.

6 TWO-WAY CURB RAMP (5-FT LANDING)
N.T.S.

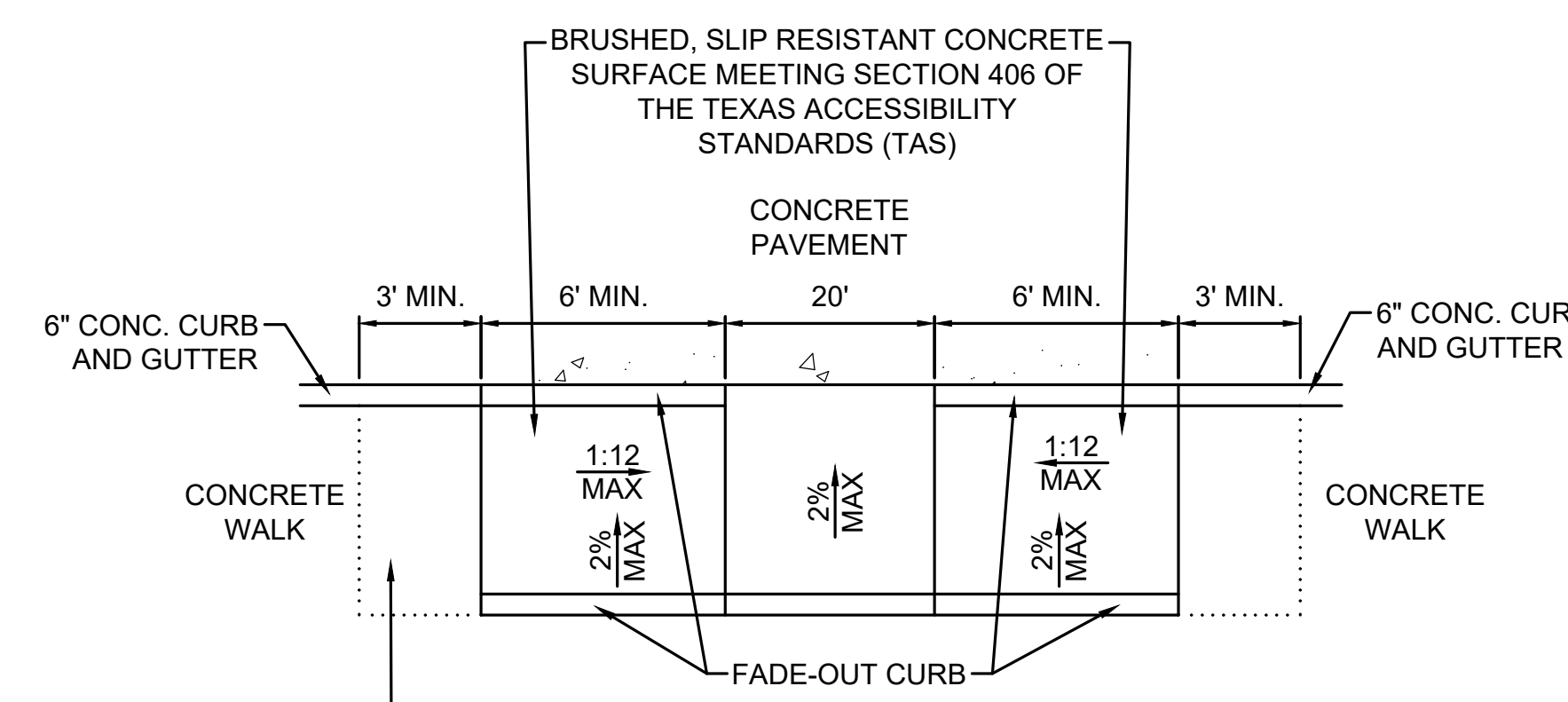

NOTES:
1. MAXIMUM RUNNING SLOPE FOR ALL PATHS IS 5%;
MAXIMUM CROSS SLOPE IS 2%; FOR THE FIRST FIVE
FEET FROM THE DOOR A 2% SLOPE (MAX) MUST BE
MAINTAINED.
2. SIGNAGE AND MARKINGS TO BE IN ACCORDANCE
WITH FEDERAL, STATE, AND LOCAL REGULATIONS.

7 TWO-WAY CURB RAMP (20-FT LANDING)
N.T.S.

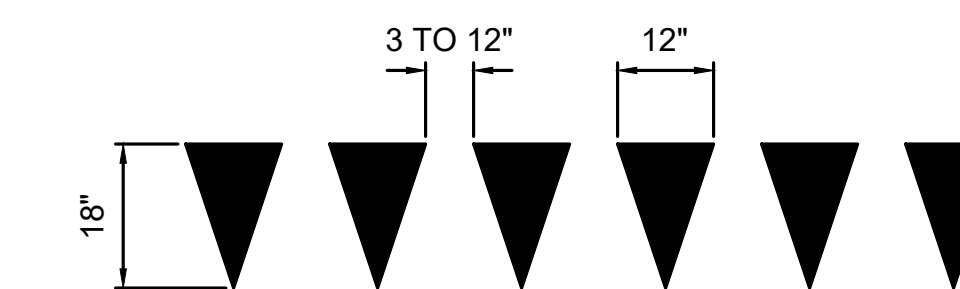

8 YIELD LINE
N.T.S.

BORDER RELEASE DATE: October 16, 2021
01/20/2021 14:09:09 C:\Users\jrc2333\OneDrive\Documents\HOK\DAL\DFW\Int'l Airport - CTA Expansion Program\Project Files\01_CTA - Terminal C Garages and Roadways\DWG-TC-CP50-0101-PavementDetails.dwg



DALLAS
FORT WORTH
INTERNATIONAL
AIRPORT

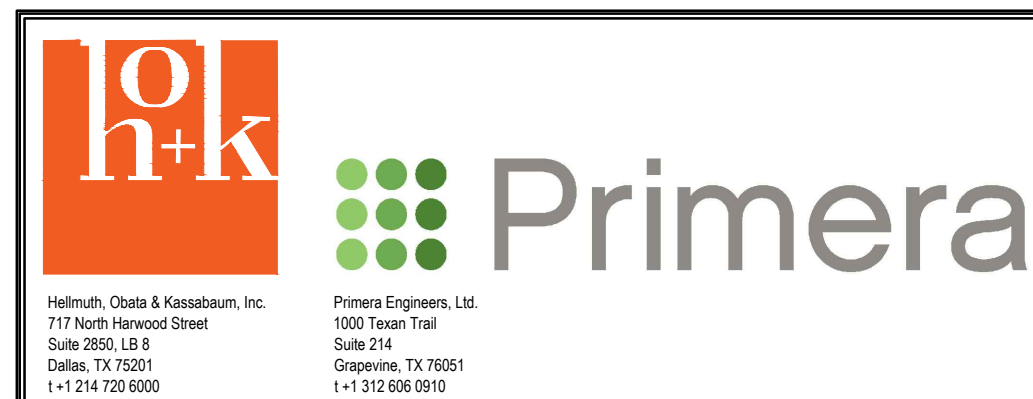

DRAWN BY: SJP
APPROVED BY: JMA
ISSUE DATE: 2022-07-28
NOT FOR BID OR CONSTRUCTION

NO.	DATE	DESCRIPTION
0001	01-20-20	30% DESIGN
0002	01-09	30% DESIGN
0003	01-01	100% DESIGN
0004	01-28	100% DESIGN FOR PERMIT (D/P)

TERMINAL C GARAGE & ROADWAYS
PAVEMENT DETAILS

PROJECT NUMBER: TFD-007

PERMIT NUMBER: B22-0023

SHEET NUMBER
CP501-900R

SCALE(S) AS NOTED ON THIS SHEET ARE BASED ON A FULL SIZE 30 X 42 SHEET.

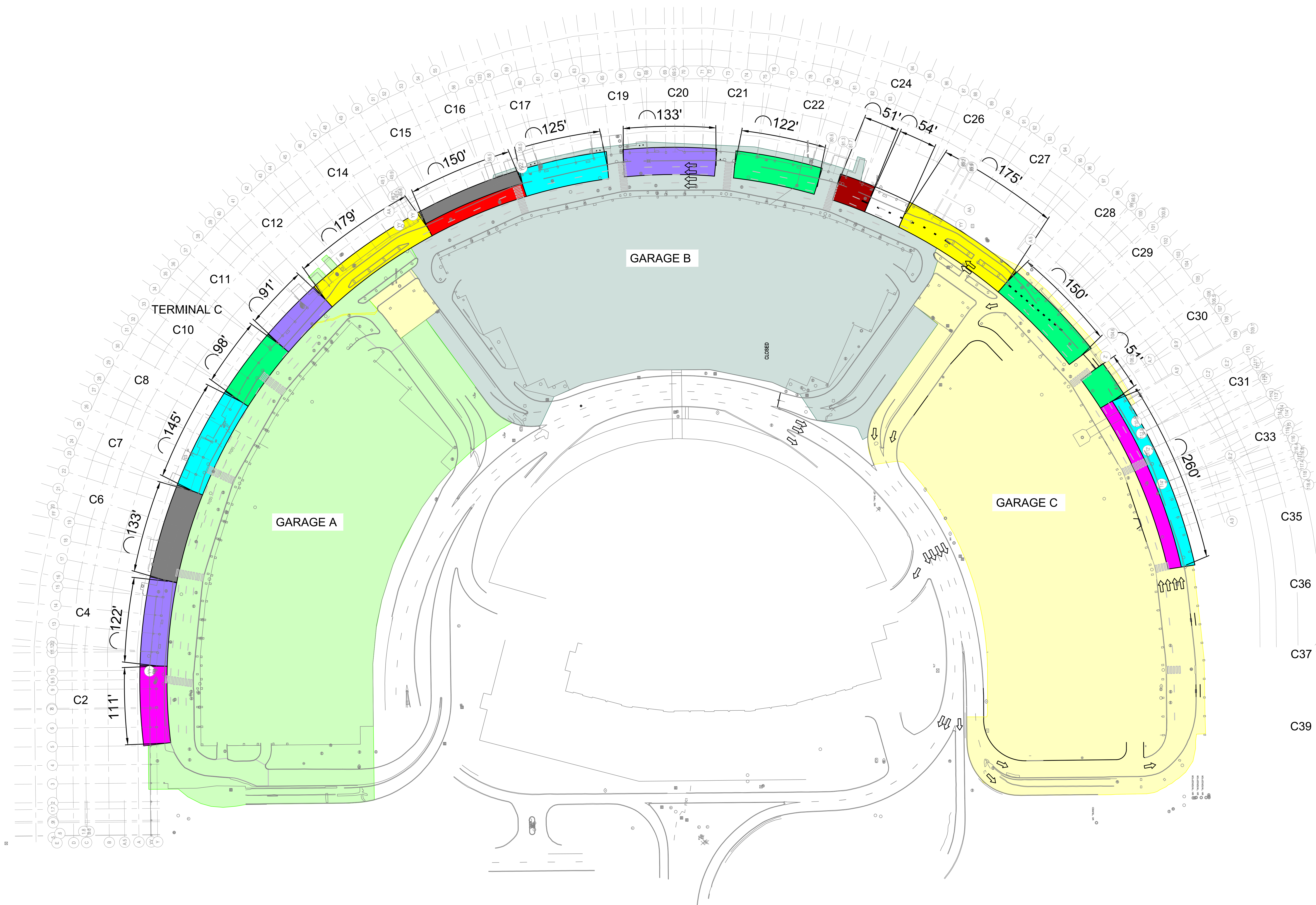

PHASING LEGEND:

- PHASE 1 (2 YEARS)
- PHASE 2 (1 YEAR)
- PHASE 3 (1 YEAR 3 MONTHS)

CURBSIDE LEGEND:

- POV
- RIDE APP
- TERMINAL LINK
- COURTESY VAN
- RENTAL CAR
- EXPRESS PARKING
- TAXI
- CHARTER BUS
- SHARED RIDE
- EMPLOYEE BUS
- REMOTE

MAINTENANCE OF TRAFFIC LEGEND:

- WORK ZONE
- CHANNELIZING DEVICES
- TRAFFIC FLOW ARROW

CONTRACTOR TO PROVIDE TEMPORARY SIGNAGE FOR CURBSIDE ALLOCATION AS FOLLOWS:

1. REMOVE ALL SIGNAGE ON UPPER AND LOWER ROADWAYS PERTAINING TO CURBSIDE USAGE AT THE START OF PHASE 1 FOR ALL CURBSIDE AREAS.
2. PROVIDE TEMPORARY SIGNAGE ON MOVABLE STANDS LABELING CURB USAGE, I.E., "EMPLOYEE BUS", (SEE DETAIL ON SHEET C-101-900R). MINIMUM OF 100 SIGNS WILL BE REQUIRED.
3. PROVIDE A SIGN FOR EVERY 60 FEET OF CURBSIDE. AT A MINIMUM 2 SIGNS PER ALLOCATED AREA (I.E., IF CURBSIDE ALLOCATION IS 150 FEET, 3 SIGNS REQUIRED).
4. RELOCATE SIGNS AS REQUIRED DURING EACH PHASE OF CONSTRUCTION.
5. REPLACE / REPAIR SIGNS AS NECESSARY.
6. DFW OPERATIONS WILL MANAGE ACTIVE CURBSIDE ACTIVITIES AND PASSENGERS DURING CONSTRUCTION

SUB-PHASE 0 DURATION: 6 MONTHS

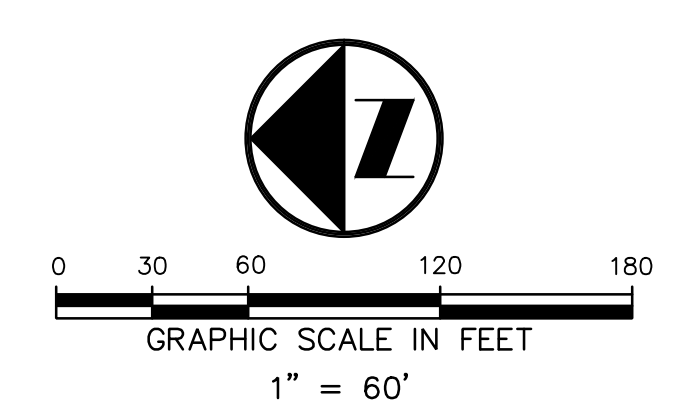

BORDER RELEASE DATE: October 16, 2021
 01/22/2021 10:59:09 AM C:\Users\jmc2003\OneDrive\Documents\DFW\101-900R-CurbsideAllocationLower.dwg
 C:\Users\jmc2003\OneDrive\Documents\DFW\101-900R-CurbsideAllocationLower.dwg



DALLAS
FORT WORTH
INTERNATIONAL
AIRPORT

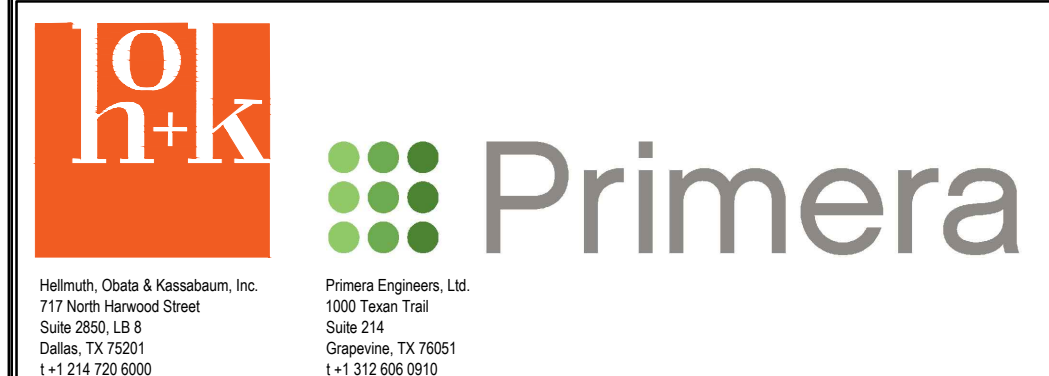

DRAWN BY: JMR
APPROVED BY: JMA
ISSUE DATE: 2022-07-28
NOT FOR BID OR CONSTRUCTION

NO.	DATE	DESCRIPTION
1	2022-07-28	100% DESIGN
2	2022-07-28	100% DESIGN FOR PERMIT (D/P)

TERMINAL C GARAGE & ROADWAYS
CURBSIDE ALLOCATION - SUB PHASE 0 (LOWER LEVEL)

PROJECT NUMBER: TFD-007

PERMIT NUMBER: B22-0023

SHEET NUMBER
C-102-900R

SCALE(S) AS NOTED ON THIS SHEET ARE BASED ON A FULL SIZE 30 X 42 SHEET.

BORDER RELEASE DATE: October 16, 2021
 01/20/2021 10:59:09 AM
 C:\Users\jrc2020\OneDrive\Documents\DFW\101-900R-CurbsideAllocationLower.dwg

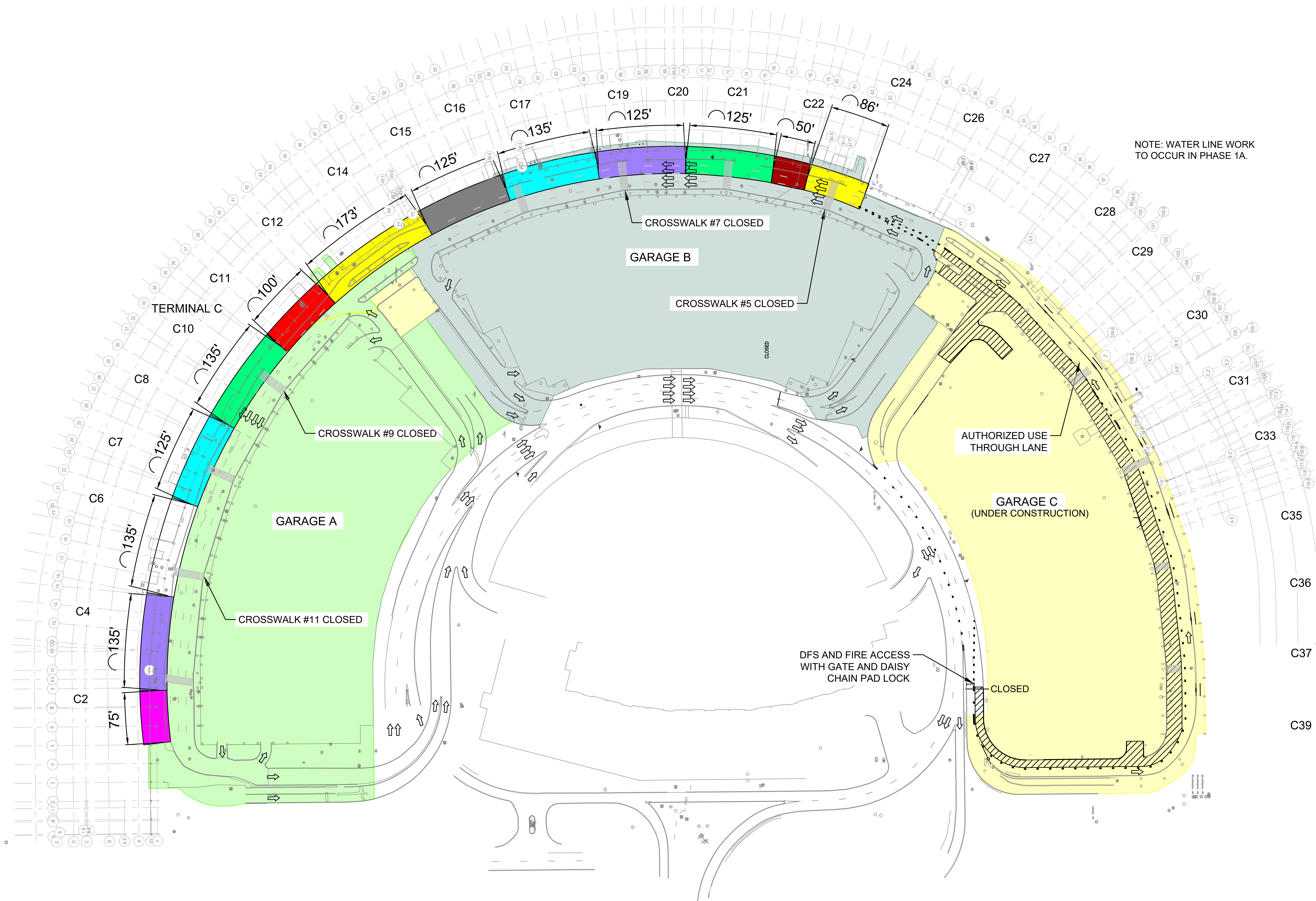

PHASING LEGEND:

- PHASE 1 (2 YEARS)
- PHASE 2 (1 YEAR)
- PHASE 3 (1 YEAR 3 MONTHS)

CURBSIDE LEGEND:

- POV
- RIDE APP
- TERMINAL LINK
- COURTESY VAN
- RENTAL CAR
- EXPRESS PARKING
- TAXI
- CHARTER BUS
- SHARED RIDE
- EMPLOYEE BUS
- REMOTE

MAINTENANCE OF TRAFFIC LEGEND:

- WORK ZONE
- CHANNELIZING DEVICES
- TRAFFIC FLOW ARROW

- CONTRACTOR TO PROVIDE TEMPORARY SIGNAGE FOR CURBSIDE ALLOCATION AS FOLLOWS:
1. REMOVE ALL SIGNAGE ON UPPER AND LOWER ROADWAYS PERTAINING TO CURBSIDE USAGE AT THE START OF PHASE 1 FOR ALL CURBSIDE AREAS.
 2. PROVIDE TEMPORARY SIGNAGE ON MOVABLE STANDS LABELING CURB USAGE, I.E., "EMPLOYEE BUS" (SEE DETAIL ON SHEET C-101-900R). MINIMUM OF 100 SIGNS WILL BE REQUIRED.
 3. PROVIDE A SIGN FOR EVERY 60 FEET OF CURBSIDE. AT A MINIMUM 2 SIGNS PER ALLOCATED AREA (I.E., IF CURBSIDE ALLOCATION IS 150 FEET, 3 SIGNS REQUIRED).
 4. RELOCATE SIGNS AS REQUIRED DURING EACH PHASE OF CONSTRUCTION.
 5. REPLACE / REPAIR SIGNS AS NECESSARY.
 6. DFW OPERATIONS WILL MANAGE ACTIVE CURBSIDE ACTIVITIES AND PASSENGERS DURING CONSTRUCTION

PHASE 1A DURATION: 6 - 9 MONTHS

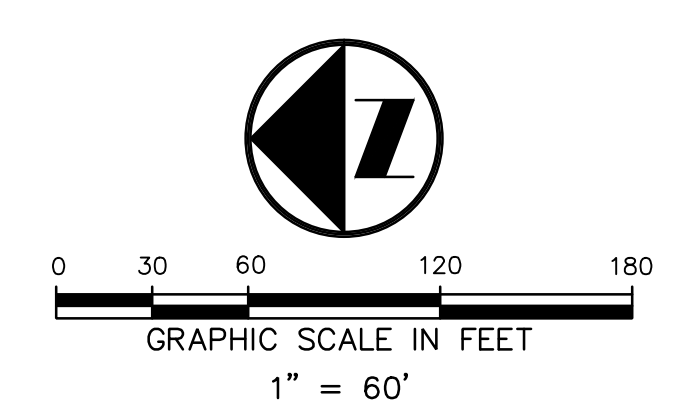

2330 N INTERNATIONAL PARKWAY
DFW AIRPORT, TX 75261



DRAWN BY: JMR
APPROVED BY: JMA
ISSUE DATE: 2022-07-28
NOT FOR BID OR CONSTRUCTION

NO.	DATE	DESCRIPTION
1	2022-07-28	100% DESIGN
2	2022-07-28	100% DESIGN FOR PERMIT (D/P)

TERMINAL C GARAGE & ROADWAYS
CURBSIDE ALLOCATION - PHASE 1A (LOWER LEVEL)
PROJECT NUMBER: TFD-007
PERMIT NUMBER: B22-0023

SHEET NUMBER
C-103-900R

SCALE(S) AS NOTED ON THIS SHEET ARE BASED ON A FULL SIZE 30 X 42 SHEET.

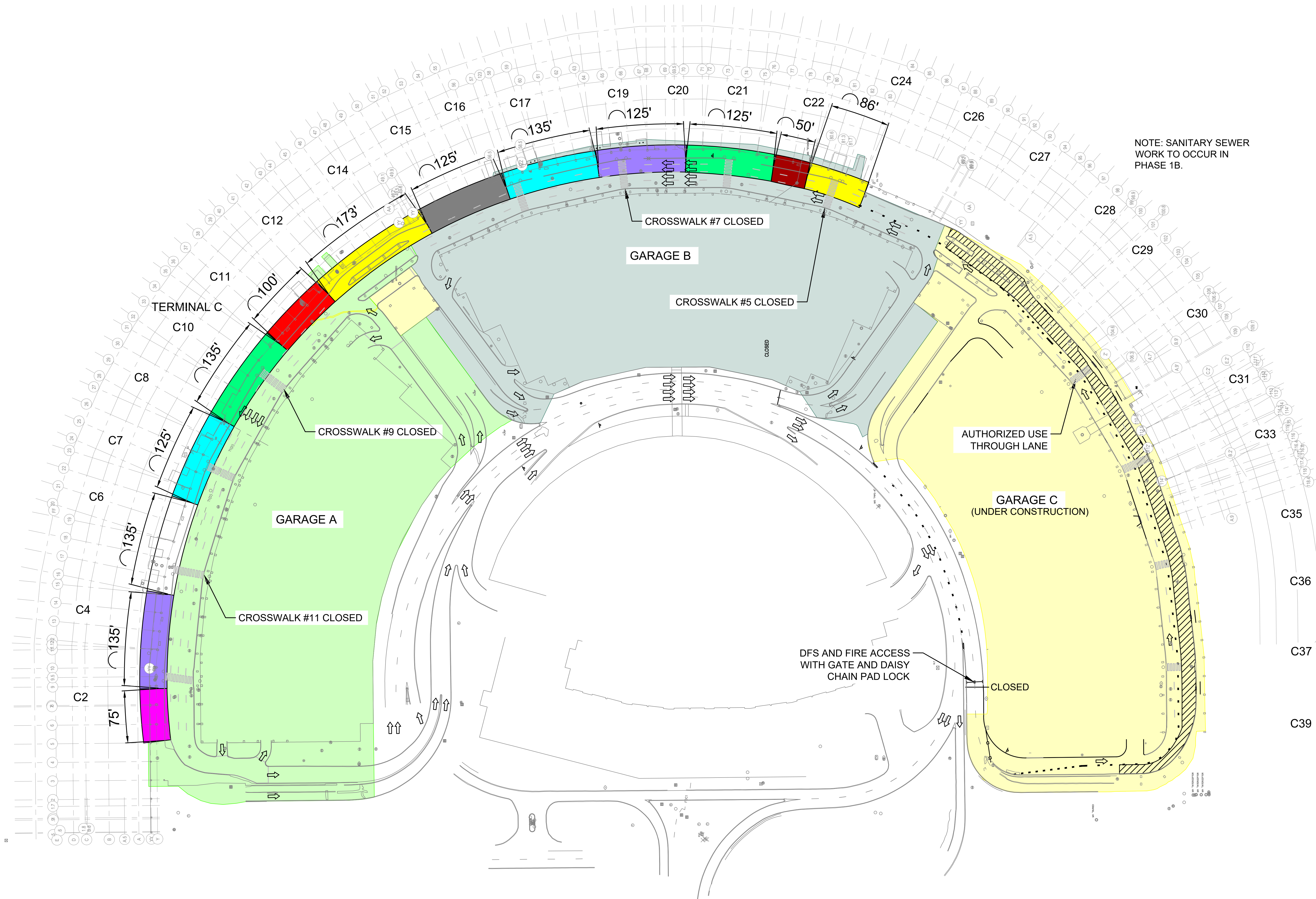

PHASING LEGEND:

- PHASE 1 (2 YEARS)
- PHASE 2 (1 YEAR)
- PHASE 3 (1 YEAR 3 MONTHS)

CURBSIDE LEGEND:

- POV
- RIDE APP
- TERMINAL LINK
- COURTESY VAN
- RENTAL CAR
- EXPRESS PARKING
- TAXI
- CHARTER BUS
- SHARED RIDE
- EMPLOYEE BUS
- REMOTE

MAINTENANCE OF TRAFFIC LEGEND:

- WORK ZONE
- CHANNELIZING DEVICES
- TRAFFIC FLOW ARROW

CONTRACTOR TO PROVIDE TEMPORARY SIGNAGE FOR CURBSIDE ALLOCATION AS FOLLOWS:

1. REMOVE ALL SIGNAGE ON UPPER AND LOWER ROADWAYS PERTAINING TO CURBSIDE USAGE AT THE START OF PHASE 1 FOR ALL CURBSIDE AREAS.
2. PROVIDE TEMPORARY SIGNAGE ON MOVABLE STANDS LABELING CURB USAGE, I.E., "EMPLOYEE BUS" (SEE DETAIL ON SHEET C-101-900R). MINIMUM OF 100 SIGNS WILL BE REQUIRED.
3. PROVIDE A SIGN FOR EVERY 60 FEET OF CURBSIDE. AT A MINIMUM 2 SIGNS PER ALLOCATED AREA (I.E., IF CURBSIDE ALLOCATION IS 150 FEET, 3 SIGNS REQUIRED).
4. RELOCATE SIGNS AS REQUIRED DURING EACH PHASE OF CONSTRUCTION.
5. REPLACE / REPAIR SIGNS AS NECESSARY.
6. DFW OPERATIONS WILL MANAGE ACTIVE CURBSIDE ACTIVITIES AND PASSENGERS DURING CONSTRUCTION

PHASE 1B DURATION: 6 - 9 MONTHS

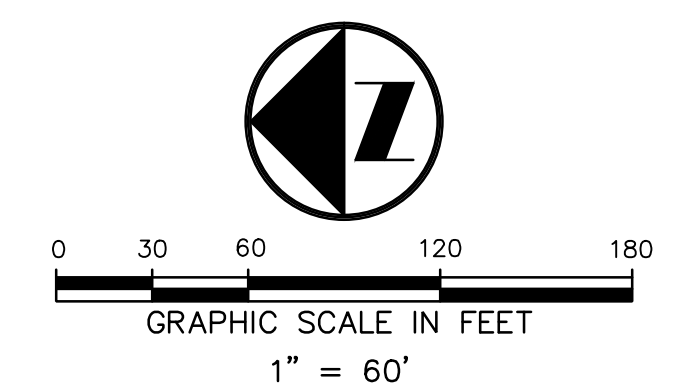

BORDER RELEASE DATE: October 16, 2021
 01/22/2021 10:09:09 AM C:\Users\jrc2020\OneDrive\Documents\DFW\101-900R-CurbsideAllocationLower.dwg
 C:\Users\jrc2020\OneDrive\Documents\DFW\101-900R-CurbsideAllocationLower.dwg



2330 N INTERNATIONAL PARKWAY
 DFW AIRPORT, TX 75261



DRAWN BY: JMR
 APPROVED BY: JMA
 ISSUE DATE: 2022-07-28
NOT FOR BID OR CONSTRUCTION

NO.	DATE	DESCRIPTION
1	2022-07-28	100% DESIGN
2	2022-07-28	100% DESIGN FOR PERMIT (DFP)

TERMINAL C GARAGE & ROADWAYS
 CURBSIDE ALLOCATION - PHASE 1B (LOWER LEVEL)

PROJECT NUMBER: TFD-007

PERMIT NUMBER: B22-0023

SHEET NUMBER
 C-104-900R

SCALE(S) AS NOTED ON THIS SHEET ARE BASED ON A FULL SIZE 30 X 42 SHEET.

BORDER RELEASE DATE: October 16, 2021
 01/20/2021 10:59:09 AM
 C:\Users\jmc2020\OneDrive\Documents\DFW\Int'l Airport - CTA Expansion Program\Project Files\01_CTA - Terminal C Garages and Roadways\DWG\DFW-TC-C-101-900R-CurbsideAllocationLower.dwg

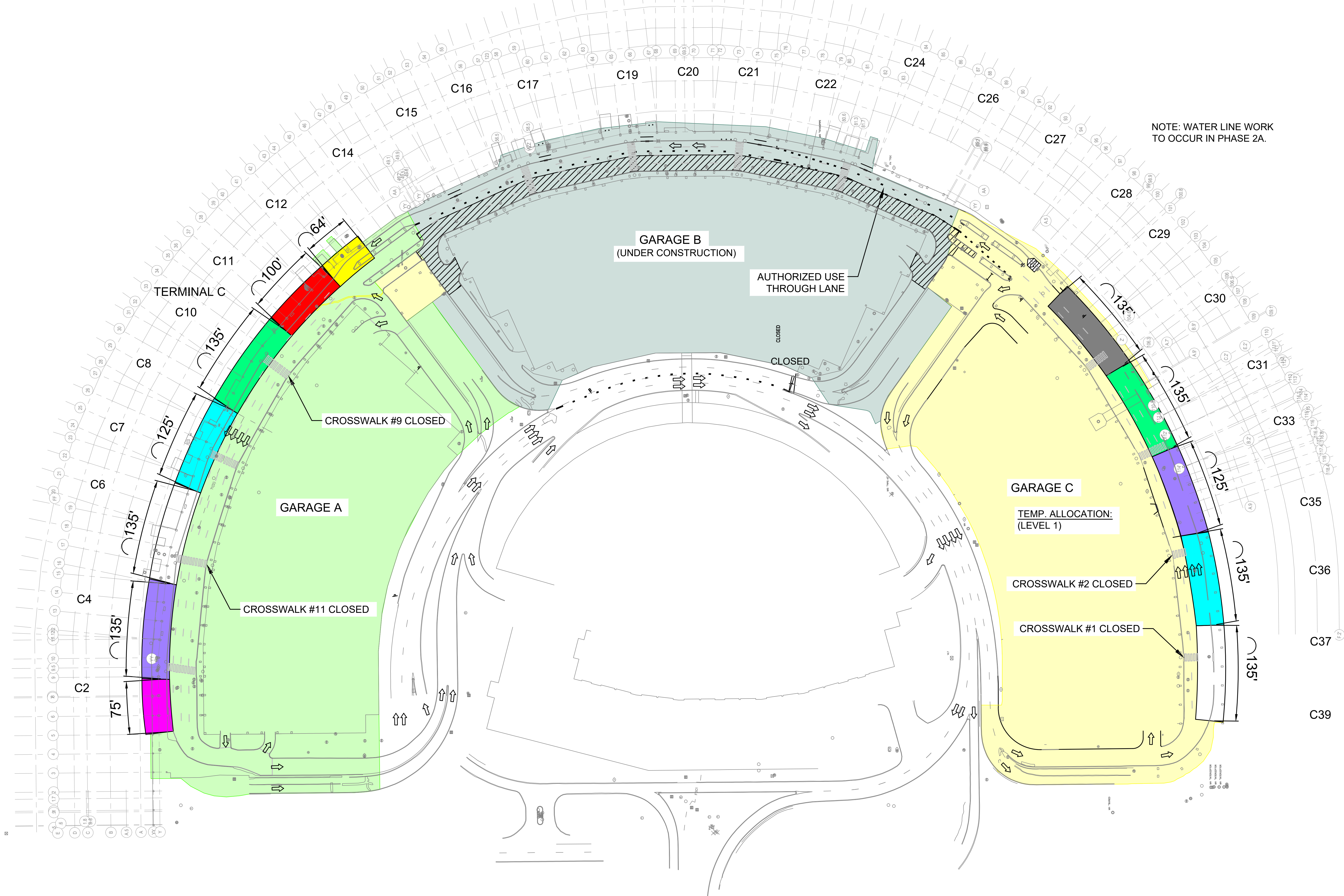

NOTE: WATER LINE WORK TO OCCUR IN PHASE 2A.

PHASING LEGEND:

- PHASE 1 (2 YEARS)
- PHASE 2 (1 YEAR)
- PHASE 3 (1 YEAR 3 MONTHS)

CURBSIDE LEGEND:

- POV
- RIDE APP
- TERMINAL LINK
- COURTESY VAN
- RENTAL CAR
- EXPRESS PARKING
- TAXI
- CHARTER BUS
- SHARED RIDE
- EMPLOYEE BUS
- REMOTE

MAINTENANCE OF TRAFFIC LEGEND:

- WORK ZONE
- CHANNELIZING DEVICES
- TRAFFIC FLOW ARROW

CONTRACTOR TO PROVIDE TEMPORARY SIGNAGE FOR CURBSIDE ALLOCATION AS FOLLOWS:

1. REMOVE ALL SIGNAGE ON UPPER AND LOWER ROADWAYS PERTAINING TO CURBSIDE USAGE AT THE START OF PHASE 1 FOR ALL CURBSIDE AREAS.
2. PROVIDE TEMPORARY SIGNAGE ON MOVABLE STANDS LABELING CURB USAGE, I.E., "EMPLOYEE BUS" (SEE DETAIL ON SHEET C-101-900R). MINIMUM OF 100 SIGNS WILL BE REQUIRED.
3. PROVIDE A SIGN FOR EVERY 60 FEET OF CURBSIDE. AT A MINIMUM 2 SIGNS PER ALLOCATED AREA (I.E., IF CURBSIDE ALLOCATION IS 150 FEET, 3 SIGNS REQUIRED).
4. RELOCATE SIGNS AS REQUIRED DURING EACH PHASE OF CONSTRUCTION.
5. REPLACE / REPAIR SIGNS AS NECESSARY.
6. DFW OPERATIONS WILL MANAGE ACTIVE CURBSIDE ACTIVITIES AND PASSENGERS DURING CONSTRUCTION

PHASE 2A DURATION: 6 - 8 MONTHS

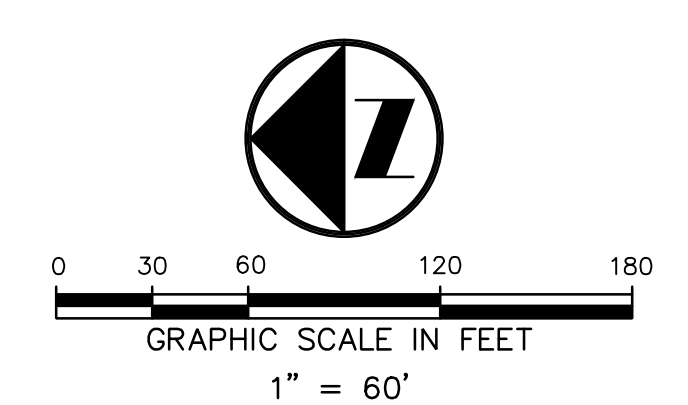

2330 N INTERNATIONAL PARKWAY
DFW AIRPORT, TX 75261



DRAWN BY: JMR
APPROVED BY: JMA
ISSUE DATE: 2022-07-28
NOT FOR BID OR CONSTRUCTION

NO.	DATE	DESCRIPTION
1	2022-07-28	100% DESIGN
2	2022-07-28	100% REVISED FOR PERMIT (RFP)

TERMINAL C GARAGE & ROADWAYS
CURBSIDE ALLOCATION - PHASE 2A (LOWER LEVEL)
PROJECT NUMBER: TFD-007
PERMIT NUMBER: B22-0023

SHEET NUMBER
C-105-900R

SCALE(S) AS NOTED ON THIS SHEET ARE BASED ON A FULL SIZE 30 X 42 SHEET.

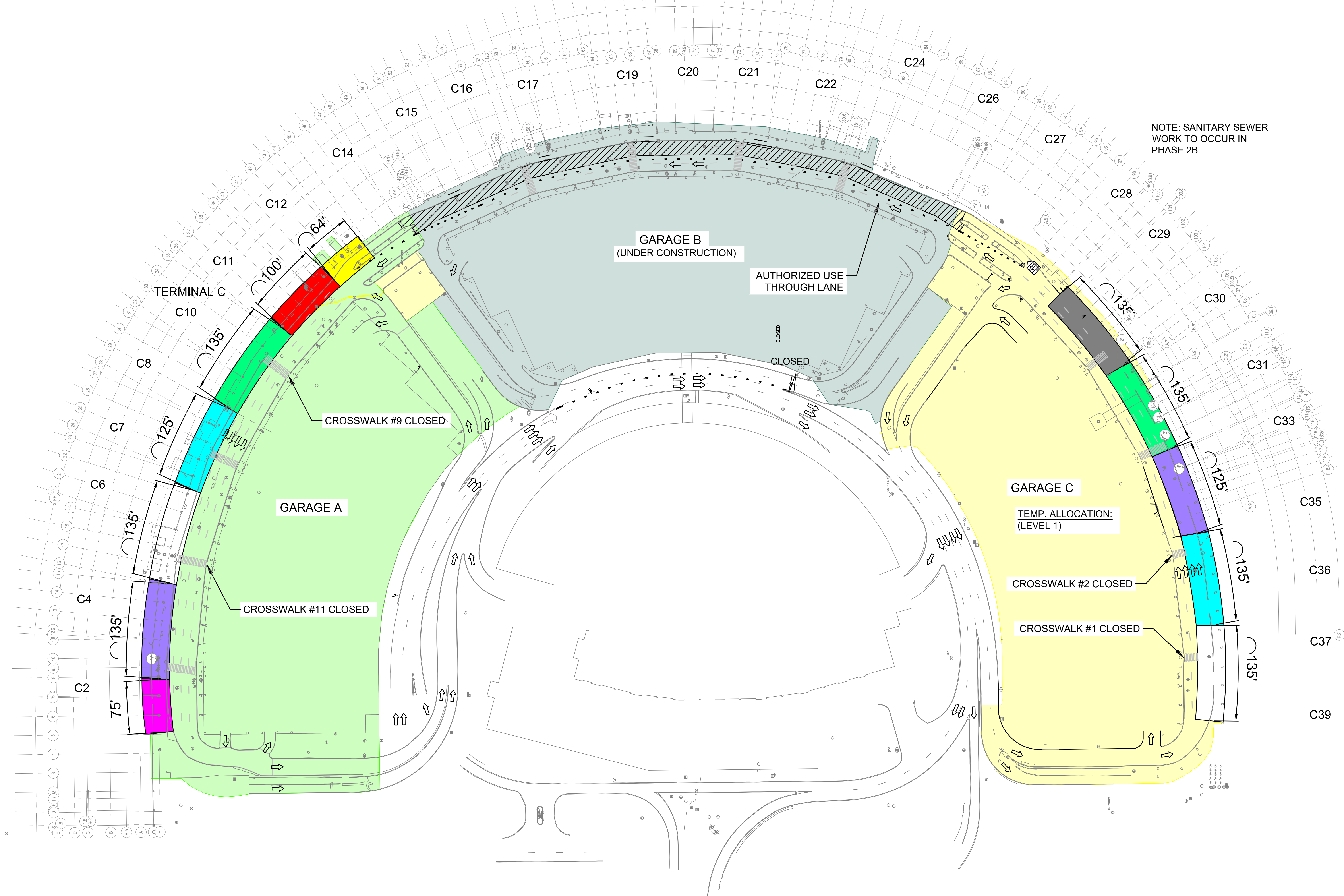

NOTE: SANITARY SEWER WORK TO OCCUR IN PHASE 2B.

PHASING LEGEND:

- PHASE 1 (2 YEARS)
- PHASE 2 (1 YEAR)
- PHASE 3 (1 YEAR 3 MONTHS)

CURBSIDE LEGEND:

- POV
- RIDE APP
- TERMINAL LINK
- COURTESY VAN
- RENTAL CAR
- EXPRESS PARKING
- TAXI
- CHARTER BUS
- SHARED RIDE
- EMPLOYEE BUS
- REMOTE

MAINTENANCE OF TRAFFIC LEGEND:

- WORK ZONE
- CHANNELIZING DEVICES
- TRAFFIC FLOW ARROW

CONTRACTOR TO PROVIDE TEMPORARY SIGNAGE FOR CURBSIDE ALLOCATION AS FOLLOWS:

1. REMOVE ALL SIGNAGE ON UPPER AND LOWER ROADWAYS PERTAINING TO CURBSIDE USAGE AT THE START OF PHASE 1 FOR ALL CURBSIDE AREAS.
2. PROVIDE TEMPORARY SIGNAGE ON MOVABLE STANDS LABELING CURB USAGE, I.E., "EMPLOYEE BUS" (SEE DETAIL ON SHEET C-101-900R). MINIMUM OF 100 SIGNS WILL BE REQUIRED.
3. PROVIDE A SIGN FOR EVERY 60 FEET OF CURBSIDE. AT A MINIMUM 2 SIGNS PER ALLOCATED AREA (I.E., IF CURBSIDE ALLOCATION IS 150 FEET, 3 SIGNS REQUIRED).
4. RELOCATE SIGNS AS REQUIRED DURING EACH PHASE OF CONSTRUCTION.
5. REPLACE / REPAIR SIGNS AS NECESSARY.
6. DFW OPERATIONS WILL MANAGE ACTIVE CURBSIDE ACTIVITIES AND PASSENGERS DURING CONSTRUCTION

PHASE 2B DURATION: 6 - 8 MONTHS

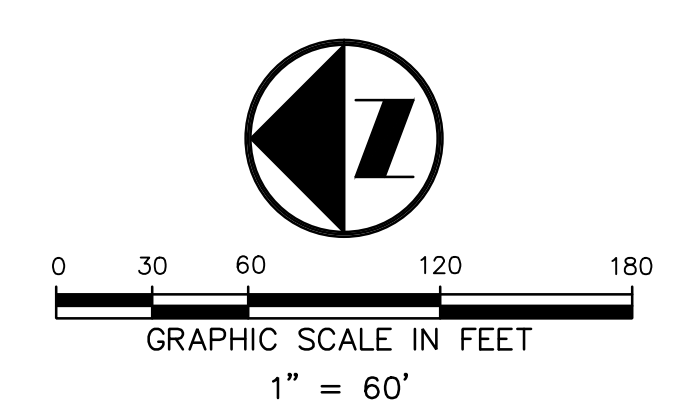

BORDER RELEASE DATE: October 16, 2021
01/20/2021 10:59:09 AM
C:\Users\jmc2020\OneDrive\Documents\DFW\101-900R-CurbsideAllocationLower.dwg



DALLAS FORT WORTH INTERNATIONAL AIRPORT
2330 N INTERNATIONAL PARKWAY
DFW AIRPORT, TX 75261

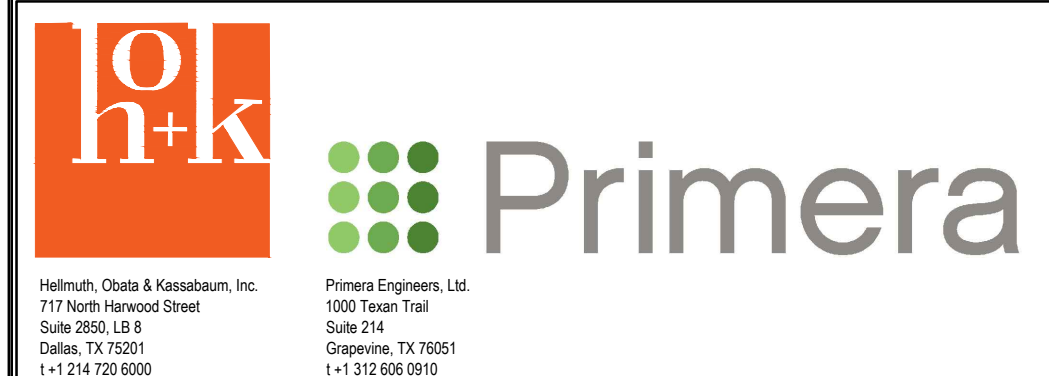

DRAWN BY: JMR
APPROVED BY: JMA
ISSUE DATE: 2022-07-28
NOT FOR BID OR CONSTRUCTION

NO.	DATE	DESCRIPTION
1	2022-07-28	100% DESIGN
2	2022-07-28	100% SUBMITTALS FOR PERMIT (SP)

TERMINAL C GARAGE & ROADWAYS
CURBSIDE ALLOCATION - PHASE 2B (LOWER LEVEL)
PROJECT NUMBER: TFD-007
PERMIT NUMBER: B22-0023

SHEET NUMBER
C-106-900R

SCALE(S) AS NOTED ON THIS SHEET ARE BASED ON A FULL SIZE 30 X 42 SHEET.

BORDER RELEASE DATE: October 16, 2021
 01/20/2021 10:59:09 AM
 C:\Users\jmc2020\OneDrive\Documents\DFW\101-900R-CurbsideAllocationLower.dwg

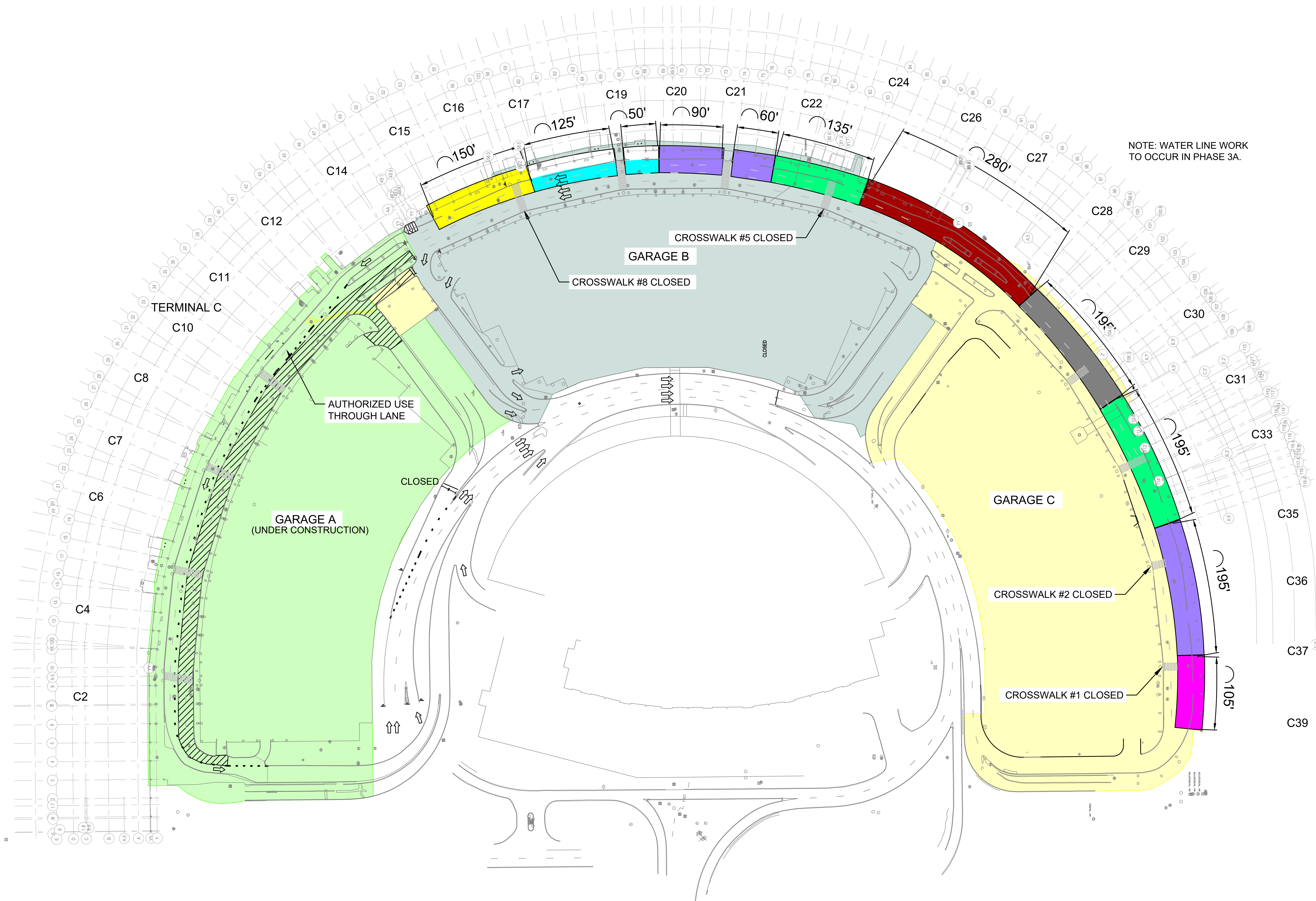

PHASING LEGEND:

- PHASE 1 (2 YEARS)
- PHASE 2 (1 YEAR)
- PHASE 3 (1 YEAR 3 MONTHS)

CURBSIDE LEGEND:

- POV
- RIDE APP
- TERMINAL LINK
- COURTESY VAN
- RENTAL CAR
- EXPRESS PARKING
- TAXI
- CHARTER BUS
- SHARED RIDE
- EMPLOYEE BUS
- REMOTE

MAINTENANCE OF TRAFFIC LEGEND:

- WORK ZONE
- CHANNELIZING DEVICES
- TRAFFIC FLOW ARROW

NOTE: WATER LINE WORK TO OCCUR IN PHASE 3A.

CONTRACTOR TO PROVIDE TEMPORARY SIGNAGE FOR CURBSIDE ALLOCATION AS FOLLOWS:

1. REMOVE ALL SIGNAGE ON UPPER AND LOWER ROADWAYS PERTAINING TO CURBSIDE USAGE AT THE START OF PHASE 1 FOR ALL CURBSIDE AREAS.
2. PROVIDE TEMPORARY SIGNAGE ON MOVABLE STANDS LABELING CURB USAGE, I.E., "EMPLOYEE BUS" (SEE DETAIL ON SHEET C-101-900R). MINIMUM OF 100 SIGNS WILL BE REQUIRED.
3. PROVIDE A SIGN FOR EVERY 60 FEET OF CURBSIDE. AT A MINIMUM 2 SIGNS PER ALLOCATED AREA (I.E., IF CURBSIDE ALLOCATION IS 150 FEET, 3 SIGNS REQUIRED).
4. RELOCATE SIGNS AS REQUIRED DURING EACH PHASE OF CONSTRUCTION.
5. REPLACE / REPAIR SIGNS AS NECESSARY.
6. DFW OPERATIONS WILL MANAGE ACTIVE CURBSIDE ACTIVITIES AND PASSENGERS DURING CONSTRUCTION

PHASE 3A DURATION: 6 - 8 MONTHS

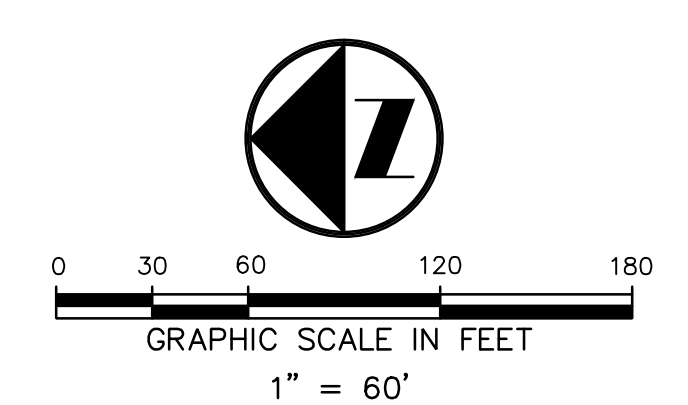

2330 N INTERNATIONAL PARKWAY
DFW AIRPORT, TX 75261



DRAWN BY: JMR
APPROVED BY: JMA
ISSUE DATE: 2022-07-28
NOT FOR BID OR CONSTRUCTION

NO.	DATE	DESCRIPTION
1	2022-05-01	100% DESIGN
2	2022-07-28	100% REVISED FOR PERMIT (RFP)

TERMINAL C GARAGE & ROADWAYS
CURBSIDE ALLOCATION - PHASE 3A (LOWER LEVEL)

PROJECT NUMBER: TFD-007

PERMIT NUMBER: B22-0023

SHEET NUMBER
C-107-900R

SCALE(S) AS NOTED ON THIS SHEET ARE BASED ON A FULL SIZE 30 X 42 SHEET.

BORDER RELEASE DATE: October 16, 2021
 01/20/2021 10:59:09 AM
 C:\Users\jrc23\OneDrive\Documents\DFW\Int'l Airport - CTR Expansion Program\Project Files\01_CTR - Terminal C Garages and Roadways\DWG\DFW-TC-C-101-900R-CurbsideAllocationLower.dwg

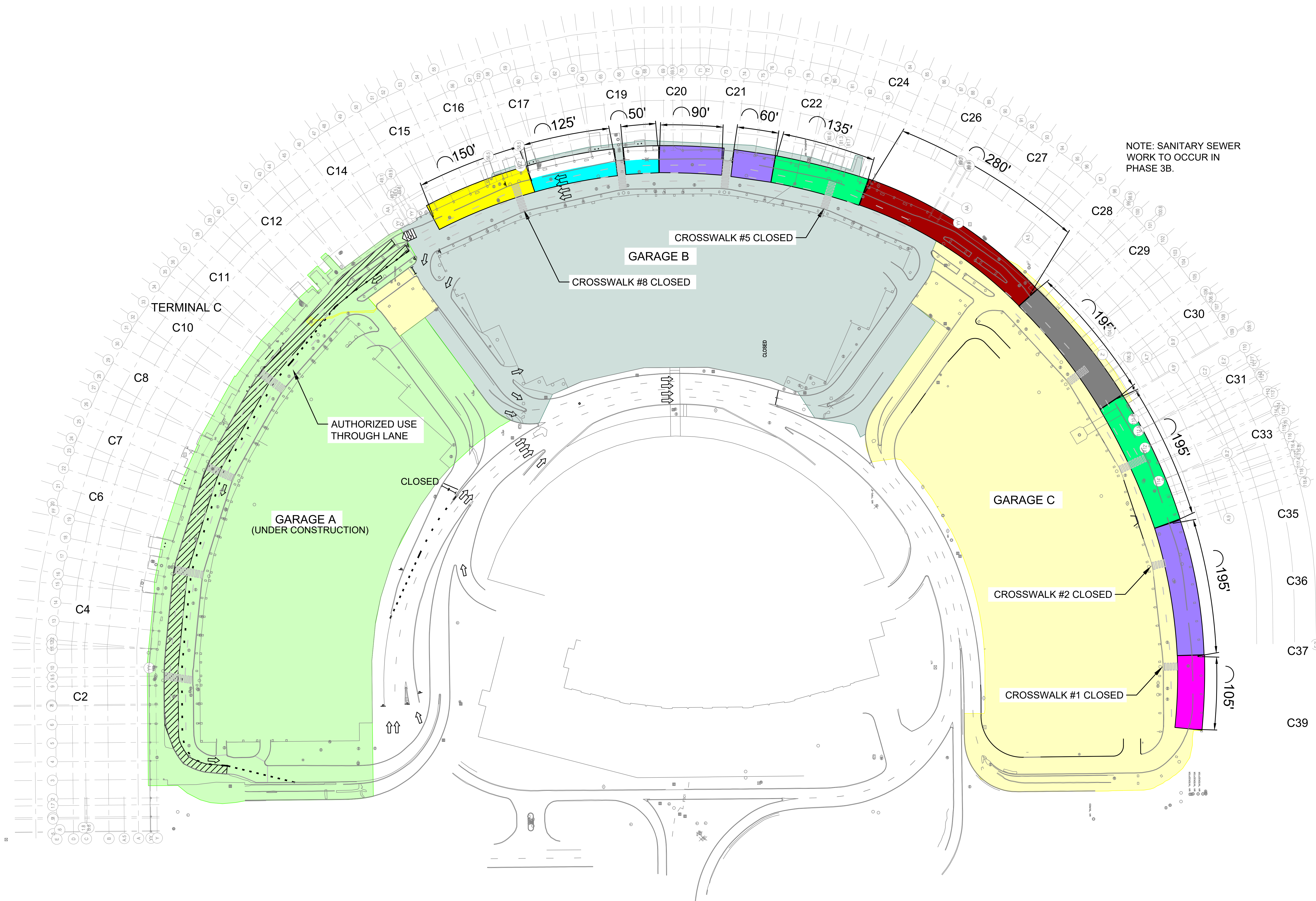

PHASING LEGEND:

- PHASE 1 (2 YEARS)
- PHASE 2 (1 YEAR)
- PHASE 3 (1 YEAR 3 MONTHS)

CURBSIDE LEGEND:

- POV
- RIDE APP
- TERMINAL LINK
- COURTESY VAN
- RENTAL CAR
- EXPRESS PARKING
- TAXI
- CHARTER BUS
- SHARED RIDE
- EMPLOYEE BUS
- REMOTE

MAINTENANCE OF TRAFFIC LEGEND:

- WORK ZONE
- CHANNELIZING DEVICES
- TRAFFIC FLOW ARROW

NOTE: SANITARY SEWER WORK TO OCCUR IN PHASE 3B.

CONTRACTOR TO PROVIDE TEMPORARY SIGNAGE FOR CURBSIDE ALLOCATION AS FOLLOWS:

1. REMOVE ALL SIGNAGE ON UPPER AND LOWER ROADWAYS PERTAINING TO CURBSIDE USAGE AT THE START OF PHASE 1 FOR ALL CURBSIDE AREAS.
2. PROVIDE TEMPORARY SIGNAGE ON MOVABLE STANDS LABELING CURB USAGE, I.E., "EMPLOYEE BUS" (SEE DETAIL ON SHEET C-101-900R). MINIMUM OF 100 SIGNS WILL BE REQUIRED.
3. PROVIDE A SIGN FOR EVERY 60 FEET OF CURBSIDE. AT A MINIMUM 2 SIGNS PER ALLOCATED AREA (I.E., IF CURBSIDE ALLOCATION IS 150 FEET, 3 SIGNS REQUIRED).
4. RELOCATE SIGNS AS REQUIRED DURING EACH PHASE OF CONSTRUCTION.
5. REPLACE / REPAIR SIGNS AS NECESSARY.
6. DFW OPERATIONS WILL MANAGE ACTIVE CURBSIDE ACTIVITIES AND PASSENGERS DURING CONSTRUCTION

PHASE 3B DURATION: 6 - 8 MONTHS

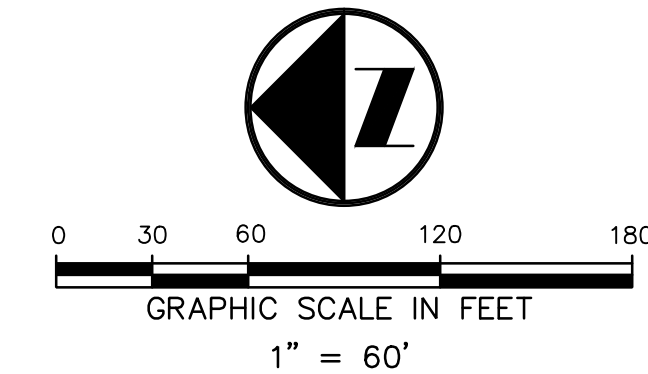

2330 N INTERNATIONAL PARKWAY
DFW AIRPORT, TX 75261

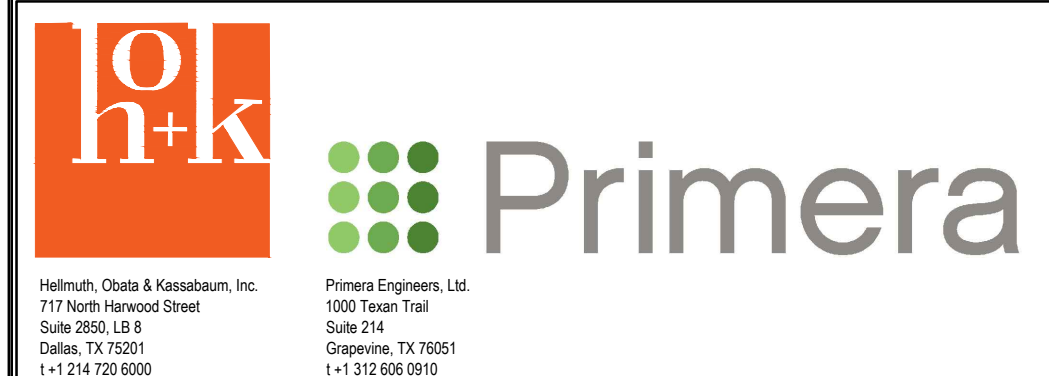

DRAWN BY: JMR
APPROVED BY: JMA
ISSUE DATE: 2022-07-28
NOT FOR BID OR CONSTRUCTION

NO.	DATE	DESCRIPTION
2022-07-28	100% DESIGN	
2022-07-28	100% DESIGN FOR PERMIT (D/P)	

TERMINAL C GARAGE & ROADWAYS
CURBSIDE ALLOCATION - PHASE 3B (LOWER LEVEL)
PROJECT NUMBER: TFD-007
PERMIT NUMBER: B22-0023

SHEET NUMBER
C-108-900R

SCALE(S) AS NOTED ON THIS SHEET ARE BASED ON A FULL SIZE 30 X 42 SHEET.

BORDER RELEASE DATE: October 16, 2021
 01/20/2021 10:09:09 AM
 C:\Users\jrc2020\OneDrive\Documents\DFW\101-900R-CurbsideAllocationLower.dwg

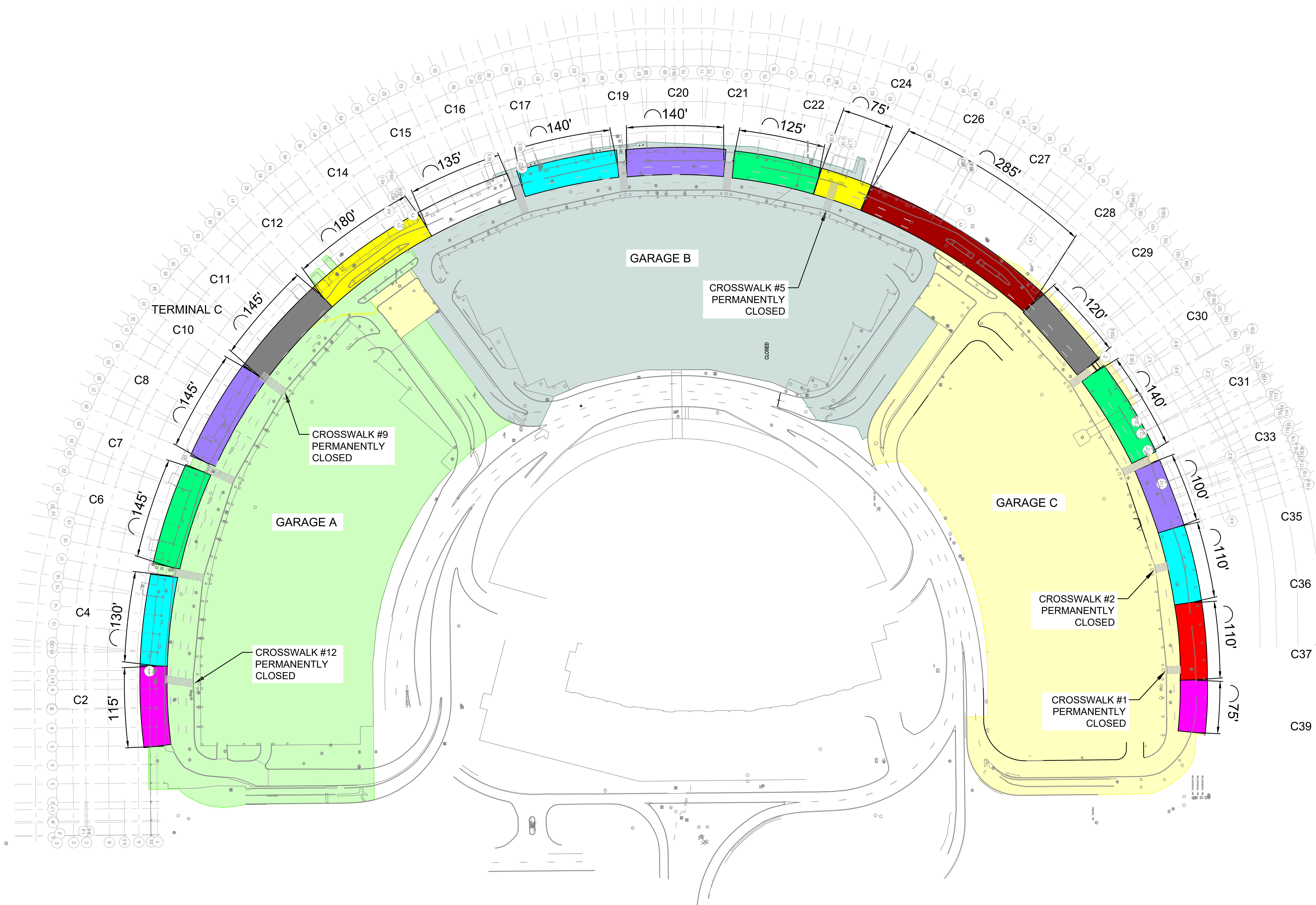

PHASING LEGEND:

- PHASE 1 (2 YEARS)
- PHASE 2 (1 YEAR)
- PHASE 3 (1 YEAR 3 MONTHS)

CURBSIDE LEGEND:

- POV
- RIDE APP
- TERMINAL LINK
- COURTESY VAN
- RENTAL CAR
- EXPRESS PARKING
- TAXI
- CHARTER BUS
- SHARED RIDE
- EMPLOYEE BUS
- REMOTE

MAINTENANCE OF TRAFFIC LEGEND:

- WORK ZONE
- CHANNELIZING DEVICES
- TRAFFIC FLOW ARROW

- CONTRACTOR TO PROVIDE TEMPORARY SIGNAGE FOR CURBSIDE ALLOCATION AS FOLLOWS:
1. REMOVE ALL SIGNAGE ON UPPER AND LOWER ROADWAYS PERTAINING TO CURBSIDE USAGE AT THE START OF PHASE 1 FOR ALL CURBSIDE AREAS.
 2. PROVIDE TEMPORARY SIGNAGE ON MOVABLE STANDS LABELING CURB USAGE, I.E., "EMPLOYEE BUS", (SEE DETAIL ON SHEET C-101-900R). MINIMUM OF 100 SIGNS WILL BE REQUIRED.
 3. PROVIDE A SIGN FOR EVERY 60 FEET OF CURBSIDE. AT A MINIMUM 2 SIGNS PER ALLOCATED AREA (I.E., IF CURBSIDE ALLOCATION IS 150 FEET, 3 SIGNS REQUIRED).
 4. RELOCATE SIGNS AS REQUIRED DURING EACH PHASE OF CONSTRUCTION.
 5. REPLACE / REPAIR SIGNS AS NECESSARY.
 6. DFW OPERATIONS WILL MANAGE ACTIVE CURBSIDE ACTIVITIES AND PASSENGERS DURING CONSTRUCTION

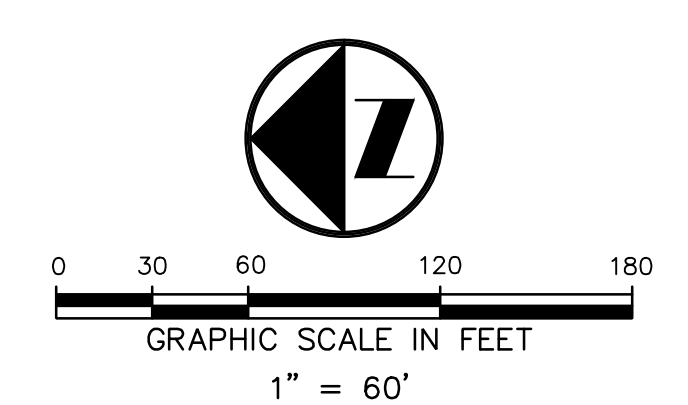

2330 N INTERNATIONAL PARKWAY
DFW AIRPORT, TX 75261



DRAWN BY: JMR
APPROVED BY: JMA
ISSUE DATE: 2022-07-28
NOT FOR BID OR CONSTRUCTION

NO.	DATE	DESCRIPTION
1	2022-05-01	100% DESIGN
2	2022-07-28	100% REVISED FOR PERMIT (RFP)

TERMINAL C GARAGE & ROADWAYS
CURBSIDE ALLOCATION - FINAL (LOWER LEVEL)
PROJECT NUMBER: TFD-007
PERMIT NUMBER: B22-0023

SHEET NUMBER
C-109-900R

SCALE(S) AS NOTED ON THIS SHEET ARE BASED ON A FULL SIZE 30 X 42 SHEET.

BORDER RELEASE DATE: October 16, 2021
 01/20/2021 10:59:09 AM
 C:\Users\jmc2020\Documents\DWG\DFW\Int'l Airport - CTA Expansion Program\Project Files\01_CTA - Terminal C Garages and Roadways\DWG\DFW-TC-C-110-900R-CurbsideAllocationUpper.dwg

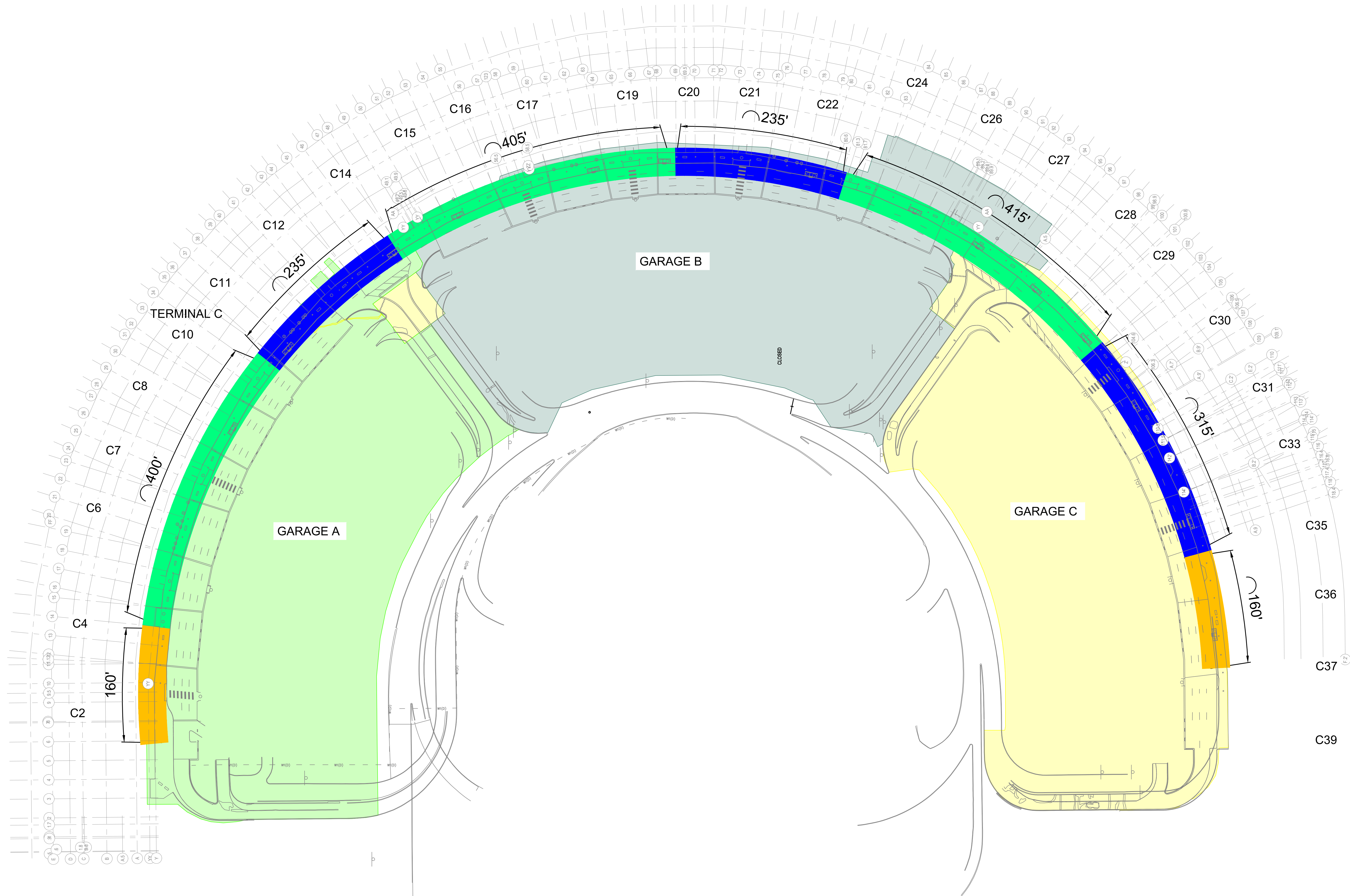

PHASING LEGEND:

- PHASE 1 (2 YEARS)
- PHASE 2 (1 YEAR)
- PHASE 3 (1 YEAR 3 MONTHS)

CURBSIDE LEGEND:

- POV
- RIDE APP
- TERMINAL LINK
- COURTESY VAN
- RENTAL CAR
- EXPRESS PARKING
- TAXI
- CHARTER BUS
- SHARED RIDE
- EMPLOYEE BUS
- REMOTE

MAINTENANCE OF TRAFFIC LEGEND:

- WORK ZONE
- CHANNELIZING DEVICES
- TRAFFIC FLOW ARROW

- CONTRACTOR TO PROVIDE TEMPORARY SIGNAGE FOR CURBSIDE ALLOCATION AS FOLLOWS:
1. REMOVE ALL SIGNAGE ON UPPER AND LOWER ROADWAYS PERTAINING TO CURBSIDE USAGE AT THE START OF PHASE 1 FOR ALL CURBSIDE AREAS.
 2. PROVIDE TEMPORARY SIGNAGE ON MOVABLE STANDS LABELING CURB USAGE, I.E., "EMPLOYEE BUS", (SEE DETAIL ON SHEET C-101-900R). MINIMUM OF 100 SIGNS WILL BE REQUIRED.
 3. PROVIDE A SIGN FOR EVERY 60 FEET OF CURBSIDE. AT A MINIMUM 2 SIGNS PER ALLOCATED AREA (I.E., IF CURBSIDE ALLOCATION IS 150 FEET, 3 SIGNS REQUIRED).
 4. RELOCATE SIGNS AS REQUIRED DURING EACH PHASE OF CONSTRUCTION.
 5. REPLACE / REPAIR SIGNS AS NECESSARY.
 6. DFW OPERATIONS WILL MANAGE ACTIVE CURBSIDE ACTIVITIES AND PASSENGERS DURING CONSTRUCTION

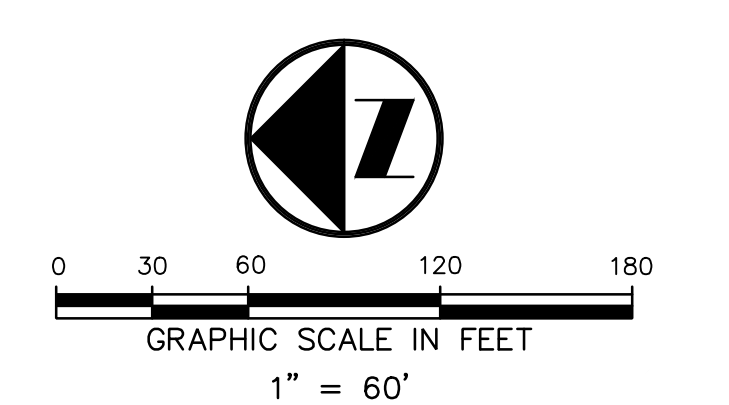

DFW DALLAS FORT WORTH INTERNATIONAL AIRPORT
 2330 N INTERNATIONAL PARKWAY
 DFW AIRPORT, TX 75261



h+k Primera
 Herrera, Obeso & Kazanjan, Inc.
 717 South Ross Street
 Suite 200, LB #
 Dallas, TX 75201
 +1 214 720 8000

DRAWN BY: JMR
 APPROVED BY: JMA
 ISSUE DATE: 2022-07-28
NOT FOR BID OR CONSTRUCTION

NO.	DATE	DESCRIPTION
1	2022-07-28	100% DESIGN
2	2022-07-28	100% SUBMITTALS FOR PERMIT (SFP)

TERMINAL C GARAGE & ROADWAYS
CURBSIDE ALLOCATION - EXISTING (UPPER LEVEL)
 PROJECT NUMBER: TFD-007
 PERMIT NUMBER: B22-0023

SHEET NUMBER
C-110-900R

SCALE(S) AS NOTED ON THIS SHEET ARE BASED ON A FULL SIZE 30 X 42 SHEET.

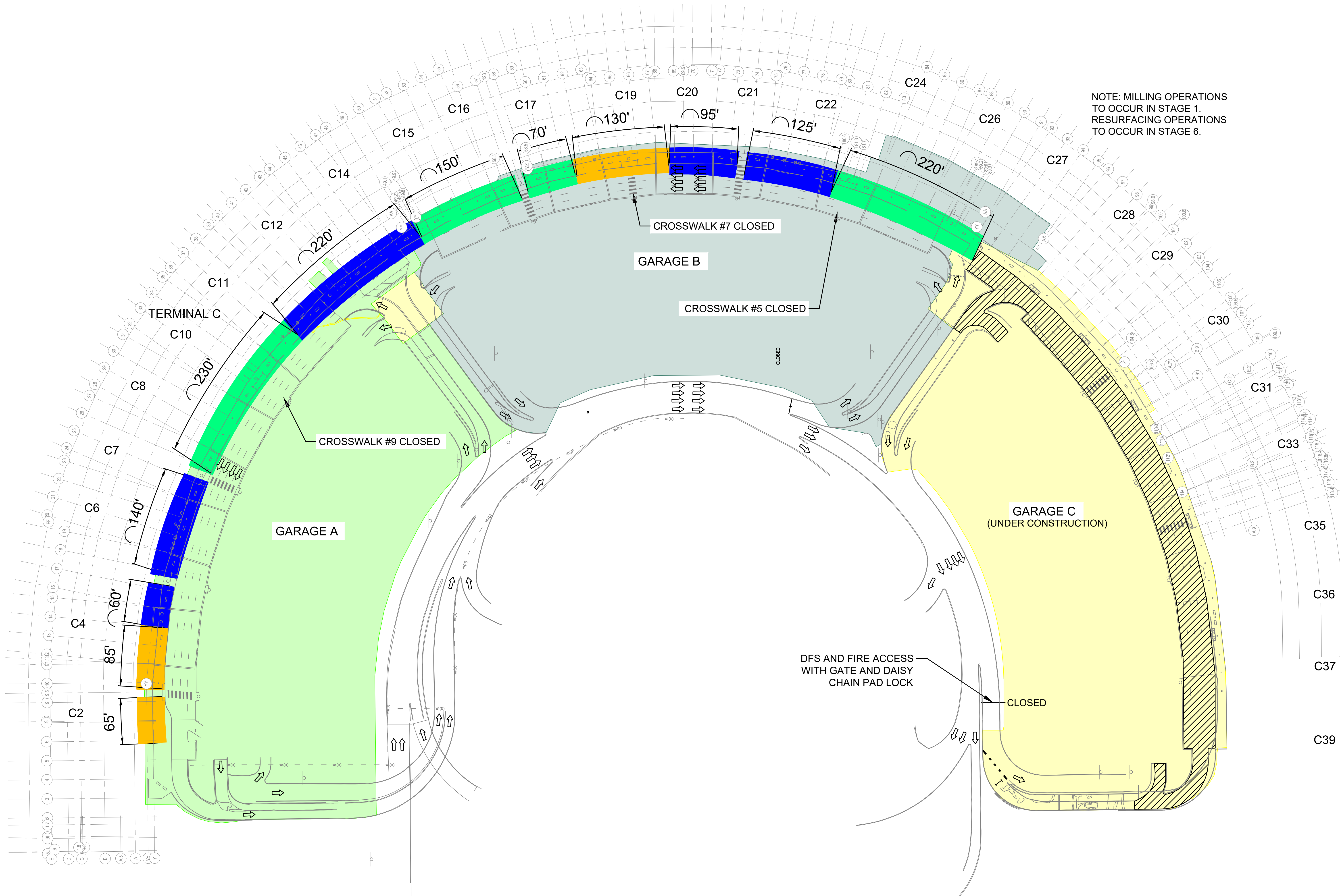

NOTE: MILLING OPERATIONS TO OCCUR IN STAGE 1. RESURFACING OPERATIONS TO OCCUR IN STAGE 6.

PHASING LEGEND:

- PHASE 1 (2 YEARS)
- PHASE 2 (1 YEAR)
- PHASE 3 (1 YEAR 3 MONTHS)

CURBSIDE LEGEND:

- POV
- RIDE APP
- TERMINAL LINK
- COURTESY VAN
- RENTAL CAR
- EXPRESS PARKING
- TAXI
- CHARTER BUS
- SHARED RIDE
- EMPLOYEE BUS
- REMOTE

MAINTENANCE OF TRAFFIC LEGEND:

- WORK ZONE
- CHANNELIZING DEVICES
- TRAFFIC FLOW ARROW

CONTRACTOR TO PROVIDE TEMPORARY SIGNAGE FOR CURBSIDE ALLOCATION AS FOLLOWS:

1. REMOVE ALL SIGNAGE ON UPPER AND LOWER ROADWAYS PERTAINING TO CURBSIDE USAGE AT THE START OF PHASE 1 FOR ALL CURBSIDE AREAS.
2. PROVIDE TEMPORARY SIGNAGE ON MOVABLE STANDS LABELING CURB USAGE, I.E., "EMPLOYEE BUS", (SEE DETAIL ON SHEET C-101-900R). MINIMUM OF 100 SIGNS WILL BE REQUIRED.
3. PROVIDE A SIGN FOR EVERY 60 FEET OF CURBSIDE. AT A MINIMUM 2 SIGNS PER ALLOCATED AREA (I.E., IF CURBSIDE ALLOCATION IS 150 FEET, 3 SIGNS REQUIRED).
4. RELOCATE SIGNS AS REQUIRED DURING EACH PHASE OF CONSTRUCTION.
5. REPLACE / REPAIR SIGNS AS NECESSARY.
6. DFW OPERATIONS WILL MANAGE ACTIVE CURBSIDE ACTIVITIES AND PASSENGERS DURING CONSTRUCTION

STAGE 1 & 6 DURATION: 3 NIGHTS PER STAGE
UPPER LEVEL STAGES TO OCCUR DURING PHASE 3

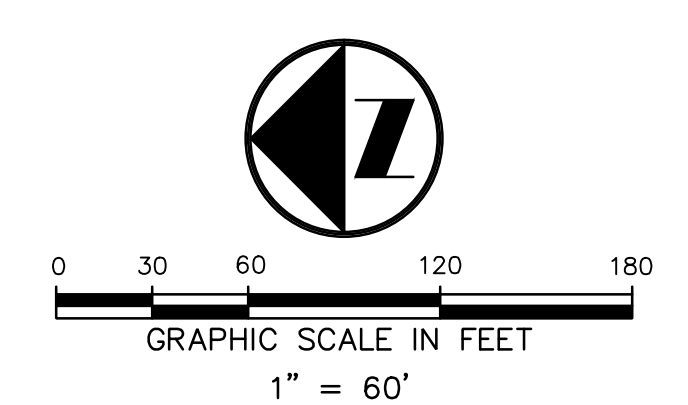

BORDER RELEASE DATE: October 16, 2021
01/20/2021 10:09:09 AM
C:\Users\jmc2020\OneDrive\Documents\DFW\101-900R-CurbsideAllocationUpper.dwg



DALLAS FORT WORTH INTERNATIONAL AIRPORT
2330 N INTERNATIONAL PARKWAY
DFW AIRPORT, TX 75261



DRAWN BY: JMR
APPROVED BY: JMA
ISSUE DATE: 2022-07-28
NOT FOR BID OR CONSTRUCTION

NO.	DATE	DESCRIPTION
1	2022-07-28	100% DESIGN
2	2022-07-28	100% DESIGN FOR PERMIT (D/P)

TERMINAL C GARAGE & ROADWAYS
CURBSIDE ALLOCATION - STAGE 1 & 6 (UPPER LEVEL)
PROJECT NUMBER: TFD-007
PERMIT NUMBER: B22-0023

SHEET NUMBER
C-111-900R

SCALE(S) AS NOTED ON THIS SHEET ARE BASED ON A FULL SIZE 30 X 42 SHEET.

BORDER RELEASE DATE: October 16, 2021
 01/20/2021 10:09:09 AM
 C:\Users\jmc2020\OneDrive\Documents\DFW-TC-C-101-900R-CurbsideAllocationUpper.dwg

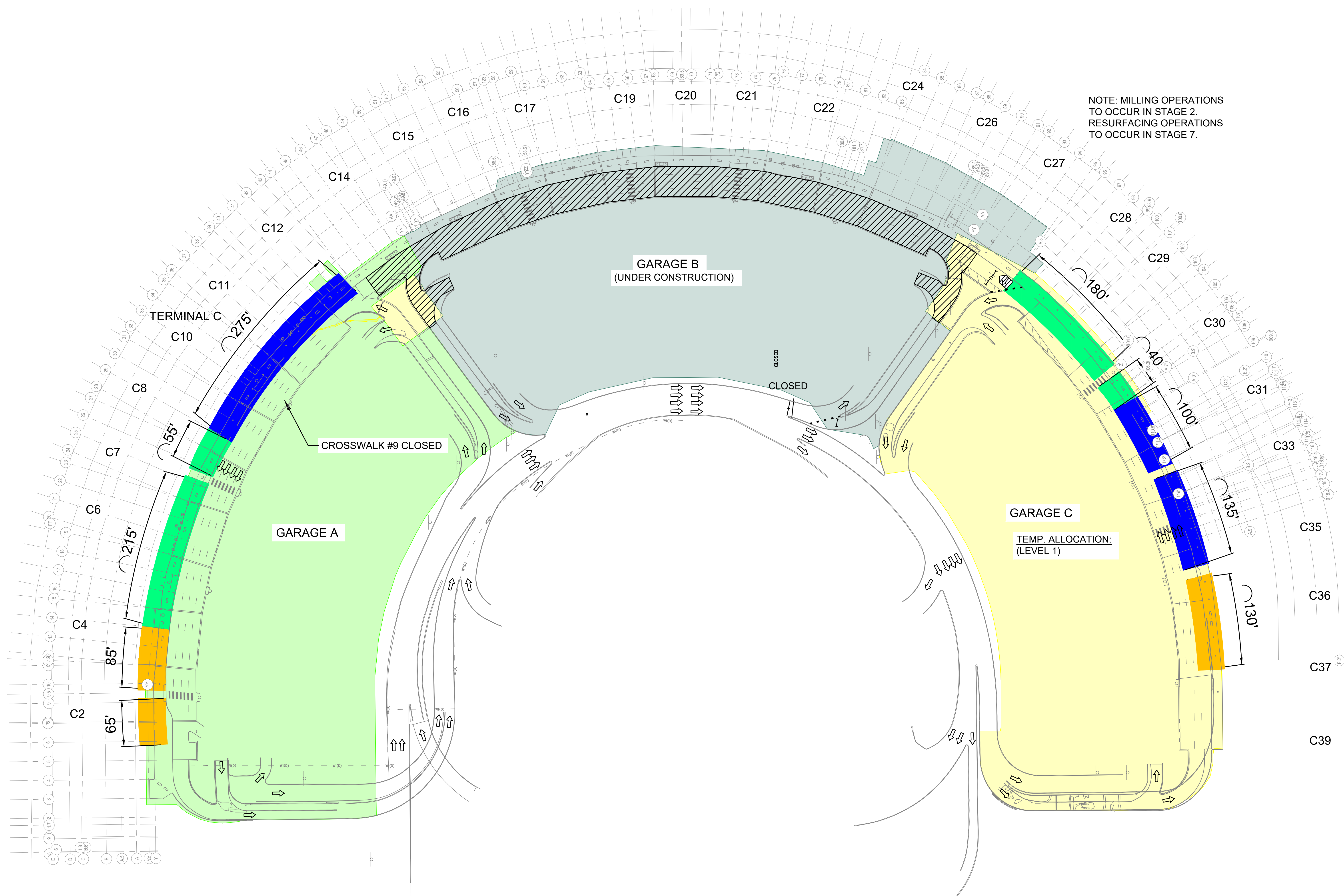

PHASING LEGEND:

- PHASE 1 (2 YEARS)
- PHASE 2 (1 YEAR)
- PHASE 3 (1 YEAR 3 MONTHS)

CURBSIDE LEGEND:

- POV
- RIDE APP
- TERMINAL LINK
- COURTESY VAN
- RENTAL CAR
- EXPRESS PARKING
- TAXI
- CHARTER BUS
- SHARED RIDE
- EMPLOYEE BUS
- REMOTE

MAINTENANCE OF TRAFFIC LEGEND:

- WORK ZONE
- CHANNELIZING DEVICES
- TRAFFIC FLOW ARROW

CONTRACTOR TO PROVIDE TEMPORARY SIGNAGE FOR CURBSIDE ALLOCATION AS FOLLOWS:

1. REMOVE ALL SIGNAGE ON UPPER AND LOWER ROADWAYS PERTAINING TO CURBSIDE USAGE AT THE START OF PHASE 1 FOR ALL CURBSIDE AREAS.
2. PROVIDE TEMPORARY SIGNAGE ON MOVABLE STANDS LABELING CURB USAGE, I.E., "EMPLOYEE BUS", (SEE DETAIL ON SHEET C-101-900R). MINIMUM OF 100 SIGNS WILL BE REQUIRED.
3. PROVIDE A SIGN FOR EVERY 60 FEET OF CURBSIDE. AT A MINIMUM 2 SIGNS PER ALLOCATED AREA (I.E., IF CURBSIDE ALLOCATION IS 150 FEET, 3 SIGNS REQUIRED).
4. RELOCATE SIGNS AS REQUIRED DURING EACH PHASE OF CONSTRUCTION.
5. REPLACE / REPAIR SIGNS AS NECESSARY.
6. DFW OPERATIONS WILL MANAGE ACTIVE CURBSIDE ACTIVITIES AND PASSENGERS DURING CONSTRUCTION

STAGE 2 & 7 DURATION: 3 NIGHTS PER STAGE
 UPPER LEVEL STAGES TO OCCUR DURING PHASE 3

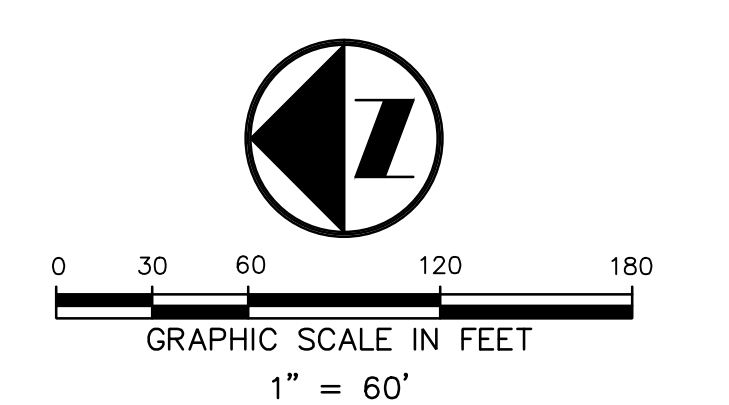

2330 N INTERNATIONAL PARKWAY
 DFW AIRPORT, TX 75261



DRAWN BY: JMR
 APPROVED BY: JMA
 ISSUE DATE: 2022-07-28
NOT FOR BID OR CONSTRUCTION

NO.	DATE	DESCRIPTION
1	2022-05-01	100% DESIGN
2	2022-05-28	100% SUBMIT FOR PERMIT (SFP)

TERMINAL C GARAGE & ROADWAYS
CURBSIDE ALLOCATION - STAGE 2 & 7 (UPPER LEVEL)
 PROJECT NUMBER: TFD-007
 PERMIT NUMBER: B22-0023

SHEET NUMBER
C-112-900R

SCALE(S) AS NOTED ON THIS SHEET ARE BASED ON A FULL SIZE 30 X 42 SHEET.

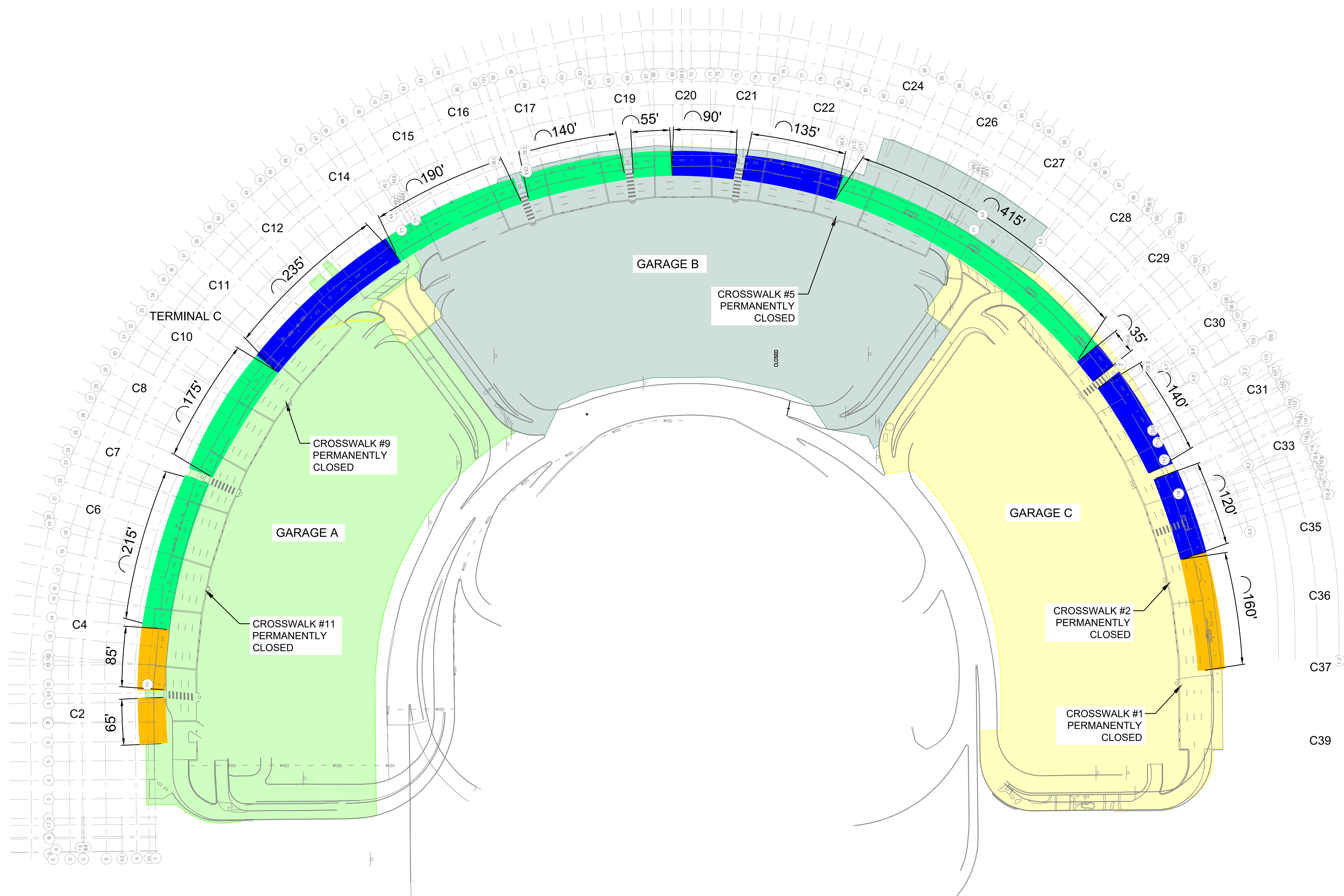

PHASING LEGEND:

- PHASE 1 (2 YEARS)
- PHASE 2 (1 YEAR)
- PHASE 3 (1 YEAR 3 MONTHS)

CURBSIDE LEGEND:

- POV
- RIDE APP
- TERMINAL LINK
- COURTESY VAN
- RENTAL CAR
- EXPRESS PARKING
- TAXI
- CHARTER BUS
- SHARED RIDE
- EMPLOYEE BUS
- REMOTE

MAINTENANCE OF TRAFFIC LEGEND:

- WORK ZONE
- CHANNELIZING DEVICES
- TRAFFIC FLOW ARROW

CONTRACTOR TO PROVIDE TEMPORARY SIGNAGE FOR CURBSIDE ALLOCATION AS FOLLOWS:

1. REMOVE ALL SIGNAGE ON UPPER AND LOWER ROADWAYS PERTAINING TO CURBSIDE USAGE AT THE START OF PHASE 1 FOR ALL CURBSIDE AREAS.
2. PROVIDE TEMPORARY SIGNAGE ON MOVABLE STANDS LABELING CURB USAGE, I.E., "EMPLOYEE BUS", (SEE DETAIL ON SHEET C-101-900R). MINIMUM OF 100 SIGNS WILL BE REQUIRED.
3. PROVIDE A SIGN FOR EVERY 60 FEET OF CURBSIDE. AT A MINIMUM 2 SIGNS PER ALLOCATED AREA (I.E., IF CURBSIDE ALLOCATION IS 150 FEET, 3 SIGNS REQUIRED).
4. RELOCATE SIGNS AS REQUIRED DURING EACH PHASE OF CONSTRUCTION.
5. REPLACE / REPAIR SIGNS AS NECESSARY.
6. DFW OPERATIONS WILL MANAGE ACTIVE CURBSIDE ACTIVITIES AND PASSENGERS DURING CONSTRUCTION

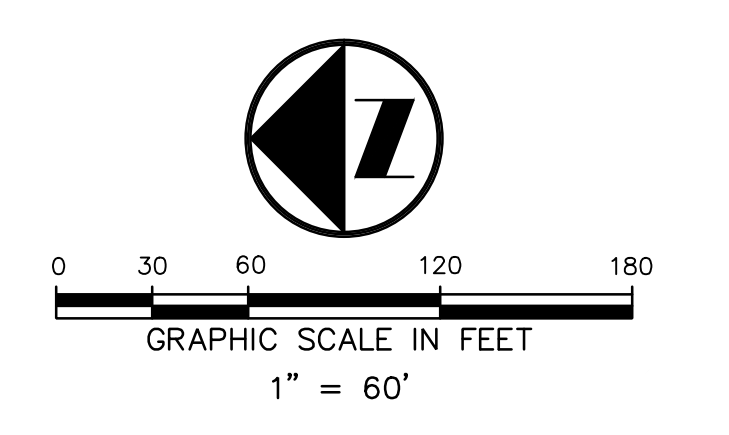

BORDER RELEASE DATE: October 16, 2021
 01/20/2021 10:09 AM
 C:\Users\jmc2020\OneDrive\Documents\DFW\101-900R-CurbsideAllocationUpper.dwg

DFW DALLAS FORT WORTH INTERNATIONAL AIRPORT
 2330 N INTERNATIONAL PARKWAY
 DFW AIRPORT, TX 75261



h+k Primera
 Highway, Design & Construction, Inc.
 777 South Ross Street
 Suite 200, LB #
 Dallas, TX 75201
 +1 214 720 8000

DRAWN BY: JMR
 APPROVED BY: JMA
 ISSUE DATE: 2022-07-28
NOT FOR BID OR CONSTRUCTION

NO.	DATE	DESCRIPTION
1	2022-07-28	100% DESIGN
2	2022-07-28	100% SUBMITTALS FOR PERMIT (SP)

TERMINAL C GARAGE & ROADWAYS
CURBSIDE ALLOCATION - FINAL (UPPER LEVEL)
 PROJECT NUMBER: TFD-007
 PERMIT NUMBER: B22-0023

SHEET NUMBER
C-114-900R

SCALE(S) AS NOTED ON THIS SHEET ARE BASED ON A FULL SIZE 30 X 42 SHEET.

MULTI-STORY CONCRETE PARKING GARAGE B

EROSION CONTROL NOTES

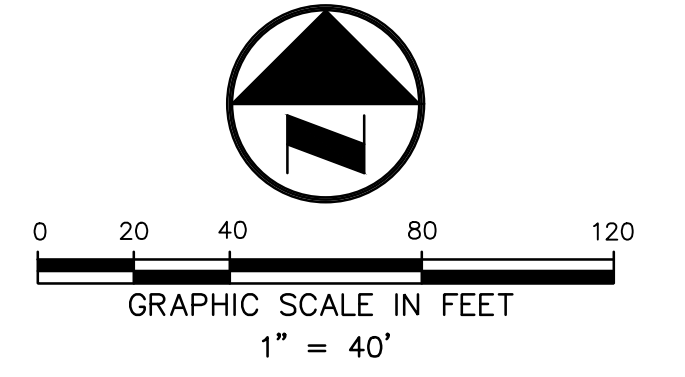

- SOIL EROSION AND SEDIMENT CONTROL (SESC) FEATURES MUST BE CONSTRUCTED PRIOR TO THE COMMENCEMENT OF ANY DEMOLITION OR CONSTRUCTION ACTIVITIES. SOIL DISTURBANCE MUST BE PHASED OR ENACTED IN SUCH A MANNER AS TO MINIMIZE EROSION SOIL STABILIZATION MEASURES (CONSIDER TIME OF YEAR, SITE CONDITIONS, AND THE USE OF TEMPORARY AND/OR PERMANENT MEASURES).
- ALL EROSION PROTECTION MUST BE MAINTAINED AND ROUTINELY CLEANED DURING CONSTRUCTION.
- PROVIDE EROSION PROTECTION ON ALL PROPOSED DRAINAGE STRUCTURES.
- INLET PROTECTION IS REQUIRED DURING ALL CONCRETE CUTTING ACTIVITY. CONCRETE SAW CUTTING SHALL USE A CLOSED VACUUM SYSTEM FOR COLLECTION OF CONCRETE SLURRY.
- UNLESS OTHERWISE INDICATED, ALL VEGETATIVE AND SESC PRACTICES WILL BE INSTALLED ACCORDING TO THE TXDOT STANDARD SPECIFICATIONS FOR CONSTRUCTION OF HIGHWAYS, STREETS, AND BRIDGES, LATEST EDITION.
- A COPY OF THE APPROVED SOIL EROSION AND SEDIMENT CONTROL (SESC) PLAN MUST BE MAINTAINED ON THE SITE AT ALL TIMES.
- THE EROSION AND SEDIMENT CONTROLS SHOWN ON THE PLANS ARE THE MINIMUM REQUIREMENTS. ADDITIONAL MEASURES MAY BE REQUIRED AS DIRECTED BY DFW, OR THEIR AUTHORIZED REPRESENTATIVE. ALL ADDITIONAL MEASURES MUST BE IN PLACE WITHIN THREE DAYS OF DISTURBANCE AND ANY EMERGENCY SESC MEASURES MUST BE INSTALLED IMMEDIATELY.
- THE CONTRACTOR MUST CLEAN UP, GRADE THE WORK AREAS AS THE PROJECT PROGRESSES, AND INSTALL EROSION PROTECTION TO ELIMINATE THE CONCENTRATION OF RUNOFF, OR MUST INSTALL APPROPRIATE SEDIMENT CONTROL DEVICES TO TRAP SEDIMENT. PAVEMENT MUST BE CLEANED DAILY OR AS NECESSARY TO REMOVE TRACK-OUT MATERIAL.
- AFTER ALL PERIMETER EROSION BARRIER IS REMOVED, THE AREAS DAMAGED BY THE PERIMETER EROSION BARRIER MUST BE RESTORED.
- IT SHALL BE THE RESPONSIBILITY OF THE CONTRACTOR TO DIVERT ALL WATER (GROUND, STORM, AND CONSTRUCTION) DURING CONSTRUCTION IN ORDER TO KEEP THE CONSTRUCTION AREAS FREE OF WATER. BYPASS PUMPING SHALL NOT BE MEASURED AND PAID FOR SEPARATELY BUT SHALL BE CONSIDERED INCIDENTAL TO THE COST OF EROSION CONTROL. IT SHALL BE THE CONTRACTOR'S RESPONSIBILITY TO SIZE THE PUMPS APPROPRIATELY.
- DURING DE-WATERING/PUMPING OPERATIONS, ONLY UNCONTAMINATED WATER SHOULD BE ALLOWED TO DISCHARGE TO PROTECTED NATURAL AREAS, WATERS OF THE STATE, OR TO A STORM SEWER SYSTEM (IN ACCORDANCE WITH LOCAL PERMITS). INLET HOSES SHOULD BE PLACED IN A STABILIZED SUMP PIT OR LOCATED AT THE SURFACE OF THE WATER IN ORDER TO LIMIT THE AMOUNT OF SEDIMENT INTAKE. PUMPING OPERATIONS MAY BE DISCHARGED TO A STABILIZED AREA THAT CONSISTS OF AN ENERGY DISSIPATING DEVICE (E.G., STONE), SEDIMENT FILTER BAG, OR BOTH. ADEQUATE EROSION AND SEDIMENT CONTROLS SHOULD BE USED DURING DE-WATERING OPERATIONS AS NECESSARY. DEWATERING SEDIMENT LADEN WATER DIRECTLY INTO FIELD TILES, STORM WATER STRUCTURES, OR WATERS OF THE U.S. IS PROHIBITED.
- TEMPORARY CONSTRUCTION EXITS WILL BE CONSTRUCTED AT ALL LOCATIONS WHERE CONSTRUCTION TRAFFIC EXITS THE SITE. THESE LOCATIONS SHALL BE DETERMINED IN THE FIELD, AS NEEDED. GRAVELED ROADS, ACCESS DRIVES, PARKING AREAS OF SUFFICIENT WIDTH AND LENGTH, AND VEHICLE WASH DOWN FACILITIES IF NECESSARY, MUST BE PROVIDED TO PREVENT THE DEPOSIT OF SOIL FROM BEING TRACKED ONTO PUBLIC OR PRIVATE ROADWAYS. ANY SOIL REACHING PUBLIC OR PRIVATE ROADWAY MUST BE REMOVED IMMEDIATELY.
- STOCK PILES OR SOIL MUST NOT BE LOCATED IN FLOOD PLAINS, RIPARIAN AREAS (VEGETATED FLOOD PLAINS), WETLANDS AND WATERS OF THE U.S., UNLESS OTHERWISE AUTHORIZED BY THE RELEVANT PERMITTING AUTHORITY. IF A STOCKPILE IS TO REMAIN IN PLACE FOR MORE THAN THREE DAYS, PERIMETER EROSION BARRIER MUST BE PROVIDED. ALL STOCKPILE LOCATIONS MUST BE APPROVED BY DFW.
- CONTRACTOR MUST INSTALL PERIMETER EROSION BARRIER AT ANY LOCATION IN WHICH SHEET FLOWS MAY RESULT IN SEDIMENT RUNOFF OUTSIDE THE CONSTRUCTION LIMITS. THE CONTRACTOR MAY USE OTHER METHODS TO CONTROL RUNOFF, INCLUDING, BUT NOT LIMITED TO, TEMPORARY DIVERSION SWALES, TEMPORARY SEDIMENT TRAPS, SHAPED DITCHES TO CONVEY WATER, ETC.
- ALL PROPOSED AND EXISTING STORM SEWER INLET STRUCTURES (INCLUDING INLETS LOCATED WITHIN THE HAUL ROUTES) MUST BE PROTECTED WITH STORM SEWER INLET PROTECTION (I.E. INLET FILTERS) PER INLET PROTECTION DETAILS IN THE PLANS. ALTERNATE TYPES OF PROTECTION MAY BE SUBMITTED FOR REVIEW AND APPROVAL BY DFW.
- SOIL DISTURBANCES SHALL BE STABILIZED WITH NAG 75 EROSION CONTROL BLANKET, MINIMUM 4" OF TOPSOIL, AND SEED MIX IN ACCORDANCE WITH TXDOT STANDARD SPECIFICATIONS FOR CONSTRUCTION OF HIGHWAYS, STREETS, AND BRIDGES, LATEST EDITION, ITEM 164 UNLESS OTHERWISE NOTED ON THE PLAN.
- THE CONTRACTOR SHALL INSPECT THE ADJACENT ROADWAY PERIODICALLY DURING EACH WORKING DAY AND ANY TRACK-OUT OF MUD, SOIL, OR DEBRIS SHALL BE CLEANED UP IMMEDIATELY. ADDITIONAL TRACK-OUT CONTROL BMPs AND/OR STABILIZED CONSTRUCTIONS ENTRANCES SHALL BE INSTALLED AS DETERMINED BY DFW.

EXISTING LEGEND

- CRIBADO CONTROL POINT
- IRON ROD FOUND
- BOLLARD
- GAS METER
- TRAFFIC SIGNAL LIGHT
- POLE
- TRAFFIC SIGNAL PULL BOX
- TRAFFIC SIGNAL CONTROL BOX
- TELECOM SERVICE BOX
- TELECOM PEDESTAL
- CATV PEDESTAL
- CATV JUNCTION BOX
- CATV APPURTENANCE
- LIGHT POLE
- CATHODIC PROTECTION
- FLAG POLE
- GENERIC MANHOLE
- POWER POLE
- GUYWIRE
- ELECTRIC MANHOLE
- ELECTRIC PULL BOX
- ELECTRIC METER
- ELECTRIC BOX
- ELECTRIC RISER
- GROUND LIGHT SIGN
- GAS PUMP
- FUEL TANK VENT TREE
- BUSH
- WASTE WATER CLEANOUT
- WASTE WATER MANHOLE
- STORM DRAIN MANHOLE
- WATER VALVE
- IRRIGATION CONTROL VALVE
- SPRINKLER HEAD
- SPIGOT
- FIRE HYDRANT
- WATER METER
- OVERHEAD UTILITY
- OVERHEAD ELECTRIC

PROPOSED LEGEND

- LD LIMITS OF DISTURBANCE (CURRENT PHASE)
- SF SEDIMENT CONTROL FENCE
SEE DETAIL EC(1)-16, SHEET CG501-900R
- IP INLET PROTECTION
SEE DETAIL, SHEET CG501-900R
- CW CONCRETE WASHOUT
SEE DETAIL 1, SHEET CG501-900R
- CE CONSTRUCTION EXIT
SEE DETAIL EC(3)-16, SHEET CG501-900R

KEY PLAN

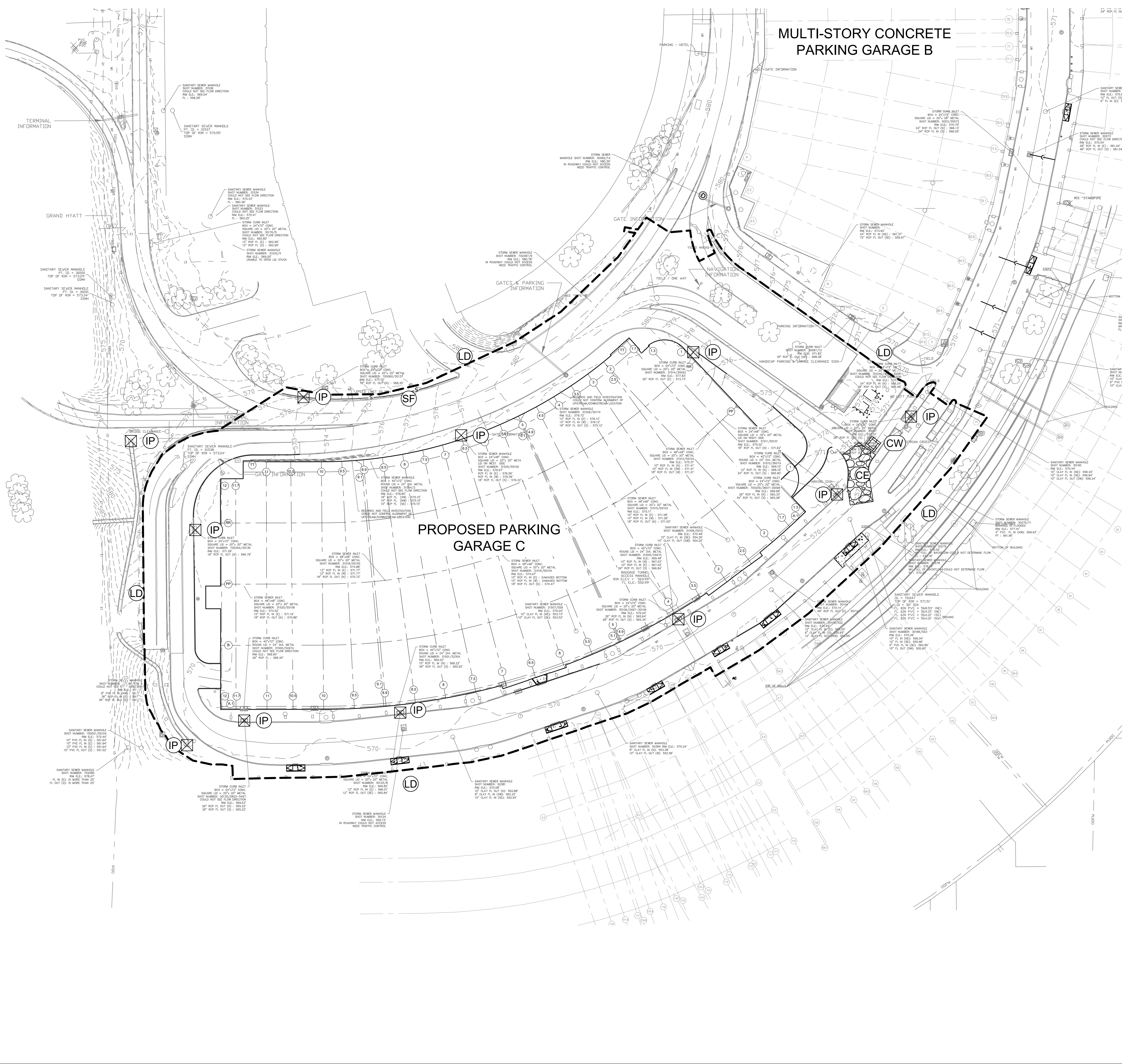
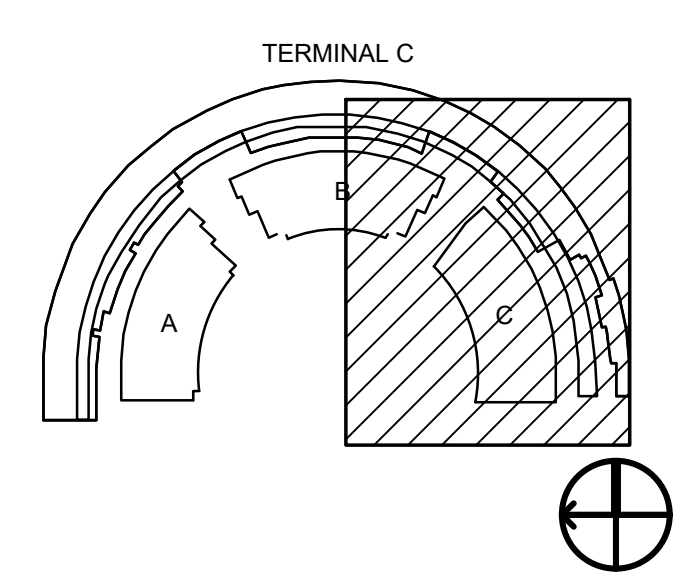

BORDER RELEASE DATE: October 16, 2021
 01/20/2021 14:59:09
 C:\Users\hpc2023\Documents\HOV\DAL\DFW\Int Airport - CTA Expansion Program\Project Files\01 CTA - Terminal C Garages and Roadways\CE/01 - CAD/Sheet/08/082-DFW-TC-CG51-0-0101-ErosionControl-Ph1.dwg



2330 N INTERNATIONAL PARKWAY
DFW AIRPORT, TX 75261



h+k **Primera**

Hobbs, Chad & Kneeburn, Inc.
777 North Terminal Drive
Suite 200, LB #
Dallas, TX 75201
+1 214 720 8000

Primera Engineers, Ltd.
300 West 7th
Suite 214
Ovington, TX 75051
+1 512 606 0910

DRAWN BY: SJP
APPROVED BY: JNA
ISSUE DATE: 2022-07-28
NOT FOR BID OR CONSTRUCTION

NO.	DATE	DESCRIPTION
2022-01-06		30% DESIGN
2022-05-01		100% DESIGN
2022-07-28		100% DESIGN FOR PERMIT (DPP)

PROJECT NUMBER: TFD-007

TERMINAL C GARAGE & ROADWAYS
EROSION CONTROL PLAN (PHASE 1)

SHEET NUMBER
CG101-900R

PERMIT NUMBER: B22-0023

SCALE(S) AS NOTED ON THIS SHEET ARE BASED ON A FULL SIZE 30 X 42 SHEET.

EROSION CONTROL NOTES

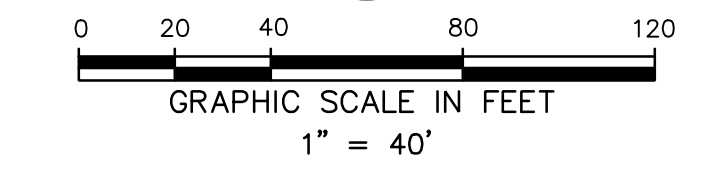
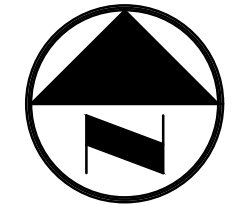

- SOIL EROSION AND SEDIMENT CONTROL (SESC) FEATURES MUST BE CONSTRUCTED PRIOR TO THE COMMENCEMENT OF ANY DEMOLITION OR CONSTRUCTION ACTIVITIES. SOIL DISTURBANCE MUST BE PHASED OR ENACTED IN SUCH A MANNER AS TO MINIMIZE EROSION SOIL STABILIZATION MEASURES (CONSIDER TIME OF YEAR, SITE CONDITIONS, AND THE USE OF TEMPORARY AND/OR PERMANENT MEASURES).
- ALL EROSION PROTECTION MUST BE MAINTAINED AND ROUTINELY CLEANED DURING CONSTRUCTION.
- PROVIDE EROSION PROTECTION ON ALL PROPOSED DRAINAGE STRUCTURES.
- INLET PROTECTION IS REQUIRED DURING ALL CONCRETE CUTTING ACTIVITY. CONCRETE SAW CUTTING SHALL USE A CLOSED VACUUM SYSTEM FOR COLLECTION OF CONCRETE SLURRY.
- UNLESS OTHERWISE INDICATED, ALL VEGETATIVE AND SESC PRACTICES WILL BE INSTALLED ACCORDING TO THE TXDOT STANDARD SPECIFICATIONS FOR CONSTRUCTION OF HIGHWAYS, STREETS, AND BRIDGES, LATEST EDITION.
- A COPY OF THE APPROVED SOIL EROSION AND SEDIMENT CONTROL (SESC) PLAN MUST BE MAINTAINED ON THE SITE AT ALL TIMES.
- THE EROSION AND SEDIMENT CONTROLS SHOWN ON THE PLANS ARE THE MINIMUM REQUIREMENTS. ADDITIONAL MEASURES MAY BE REQUIRED AS DIRECTED BY DFW, OR THEIR AUTHORIZED REPRESENTATIVE. ALL ADDITIONAL MEASURES MUST BE IN PLACE WITHIN THREE DAYS OF DISTURBANCE AND ANY EMERGENCY SESC MEASURES MUST BE INSTALLED IMMEDIATELY.
- THE CONTRACTOR MUST CLEAN UP, GRADE THE WORK AREAS AS THE PROJECT PROGRESSES, AND INSTALL EROSION PROTECTION TO ELIMINATE THE CONCENTRATION OF RUNOFF, OR MUST INSTALL APPROPRIATE SEDIMENT CONTROL DEVICES TO TRAP SEDIMENT. PAVEMENT MUST BE CLEANED DAILY OR AS NECESSARY TO REMOVE TRACK-OUT MATERIAL.
- AFTER ALL PERIMETER EROSION BARRIER IS REMOVED, THE AREAS DAMAGED BY THE PERIMETER EROSION BARRIER MUST BE RESTORED.
- IT SHALL BE THE RESPONSIBILITY OF THE CONTRACTOR TO DIVERT ALL WATER (GROUND, STORM, AND CONSTRUCTION) DURING CONSTRUCTION IN ORDER TO KEEP THE CONSTRUCTION AREAS FREE OF WATER. BYPASS PUMPING SHALL NOT BE MEASURED AND PAID FOR SEPARATELY BUT SHALL BE CONSIDERED INCIDENTAL TO THE COST OF EROSION CONTROL. IT SHALL BE THE CONTRACTOR'S RESPONSIBILITY TO SIZE THE PUMPS APPROPRIATELY.
- DURING DE-WATERING/PUMPING OPERATIONS, ONLY UNCONTAMINATED WATER SHOULD BE ALLOWED TO DISCHARGE TO PROTECTED NATURAL AREAS, WATERS OF THE STATE, OR TO A STORM SEWER SYSTEM (IN ACCORDANCE WITH LOCAL PERMITS). INLET HOSES SHOULD BE PLACED IN A STABILIZED SUMP PIT OR FLOATED AT THE SURFACE OF THE WATER IN ORDER TO LIMIT THE AMOUNT OF SEDIMENT INTAKE. PUMPING OPERATIONS MAY BE DISCHARGED TO A STABILIZED AREA THAT CONSISTS OF AN ENERGY DISSIPATING DEVICE (E.G., STONE), SEDIMENT FILTER BAG, OR BOTH. ADEQUATE EROSION AND SEDIMENT CONTROLS SHOULD BE USED DURING DE-WATERING OPERATIONS AS NECESSARY. DEWATERING SEDIMENT LADEN WATER DIRECTLY INTO FIELD TILES, STORM WATER STRUCTURES, OR WATERS OF THE U.S. IS PROHIBITED.
- TEMPORARY CONSTRUCTION EXITS WILL BE CONSTRUCTED AT ALL LOCATIONS WHERE CONSTRUCTION TRAFFIC EXITS THE SITE. THESE LOCATIONS SHALL BE DETERMINED IN THE FIELD, AS NEEDED. GRAVELED ROADS, ACCESS DRIVES, PARKING AREAS OF SUFFICIENT WIDTH AND LENGTH, AND VEHICLE WASH DOWN FACILITIES IF NECESSARY, MUST BE PROVIDED TO PREVENT THE DEPOSIT OF SOIL FROM BEING TRACKED ONTO PUBLIC OR PRIVATE ROADWAYS. ANY SOIL REACHING PUBLIC OR PRIVATE ROADWAY MUST BE REMOVED IMMEDIATELY.
- STOCK PILES OR SOIL MUST NOT BE LOCATED IN FLOOD PLAINS, RIPARIAN AREAS (VEGETATED FLOOD PLAINS), WETLANDS AND WATERS OF THE U.S., UNLESS OTHERWISE AUTHORIZED BY THE RELEVANT PERMITTING AUTHORITY. IF A STOCKPILE IS TO REMAIN IN PLACE FOR MORE THAN THREE DAYS, PERIMETER EROSION BARRIER MUST BE PROVIDED. ALL STOCKPILE LOCATIONS MUST BE APPROVED BY DFW.
- CONTRACTOR MUST INSTALL PERIMETER EROSION BARRIER AT ANY LOCATION IN WHICH SHEET FLOWS MAY RESULT IN SEDIMENT RUNOFF OUTSIDE THE CONSTRUCTION LIMITS. THE CONTRACTOR MAY USE OTHER METHODS TO CONTROL RUNOFF, INCLUDING, BUT NOT LIMITED TO, TEMPORARY DIVERSION SWALES, TEMPORARY SEDIMENT TRAPS, SHAPED DITCHES TO CONVEY WATER, ETC.
- ALL PROPOSED AND EXISTING STORM SEWER INLET STRUCTURES (INCLUDING INLETS LOCATED WITHIN THE HAUL ROUTES) MUST BE PROTECTED WITH STORM SEWER INLET PROTECTION (I.E. INLET FILTERS) PER INLET PROTECTION DETAILS IN THE PLANS. ALTERNATE TYPES OF PROTECTION MAY BE SUBMITTED FOR REVIEW AND APPROVAL BY DFW.
- SOIL DISTURBANCES SHALL BE STABILIZED WITH NAG 75 EROSION CONTROL BLANKET, MINIMUM 4" OF TOPSOIL, AND SEED MIX IN ACCORDANCE WITH TXDOT STANDARD SPECIFICATIONS FOR CONSTRUCTION OF HIGHWAYS, STREETS, AND BRIDGES, LATEST EDITION, ITEM 164 UNLESS OTHERWISE NOTED ON THE PLAN.
- THE CONTRACTOR SHALL INSPECT THE ADJACENT ROADWAY PERIODICALLY DURING EACH WORKING DAY AND ANY TRACK-OUT OF MUD, SOIL, OR DEBRIS SHALL BE CLEANED UP IMMEDIATELY. ADDITIONAL TRACK-OUT CONTROL BMPs AND/OR STABILIZED CONSTRUCTIONS ENTRANCES SHALL BE INSTALLED AS DETERMINED BY DFW.

EXISTING LEGEND

- CRIADO CONTROL POINT
- IRON ROD FOUND
- BOLLARD
- GAS METER
- TRAFFIC SIGNAL LIGHT
- POLE
- TRAFFIC SIGNAL PULL BOX
- TRAFFIC SIGNAL CONTROL BOX
- TELECOM SERVICE BOX
- TELECOM PEDESTAL
- CATV PEDESTAL
- CATV JUNCTION BOX
- CATV APPURTENANCE
- LIGHT POLE
- CATHODIC PROTECTION
- FLAG POLE
- GENERIC MANHOLE
- POWER POLE
- GUYWIRE
- ELECTRIC MANHOLE
- ELECTRIC PULL BOX
- ELECTRIC METER
- ELECTRIC BOX
- ELECTRIC RISER
- GROUND LIGHT SIGN
- GAS PUMP
- FUEL TANK VENT
- TREE
- BUSH
- WASTE WATER CLEANOUT
- WASTE WATER MANHOLE
- STORM DRAIN MANHOLE
- WATER VALVE
- IRRIGATION CONTROL VALVE
- SPRINKLER HEAD
- SPIGOT
- FIRE HYDRANT
- WATER METER
- OVERHEAD UTILITY
- OVERHEAD ELECTRIC

PROPOSED LEGEND

- (LD) LIMITS OF DISTURBANCE (CURRENT PHASE)
- (SF) SEDIMENT CONTROL FENCE
SEE DETAIL EC(1)-16, SHEET CG501-900R
- ⊗ (IP) INLET PROTECTION
SEE DETAIL, SHEET CG501-900R
- ⊞ (CW) CONCRETE WASHOUT
SEE DETAIL 1, SHEET CG501-900R
- ⊞ (CE) CONSTRUCTION EXIT
SEE DETAIL EC(3)-16, SHEET CG501-900R

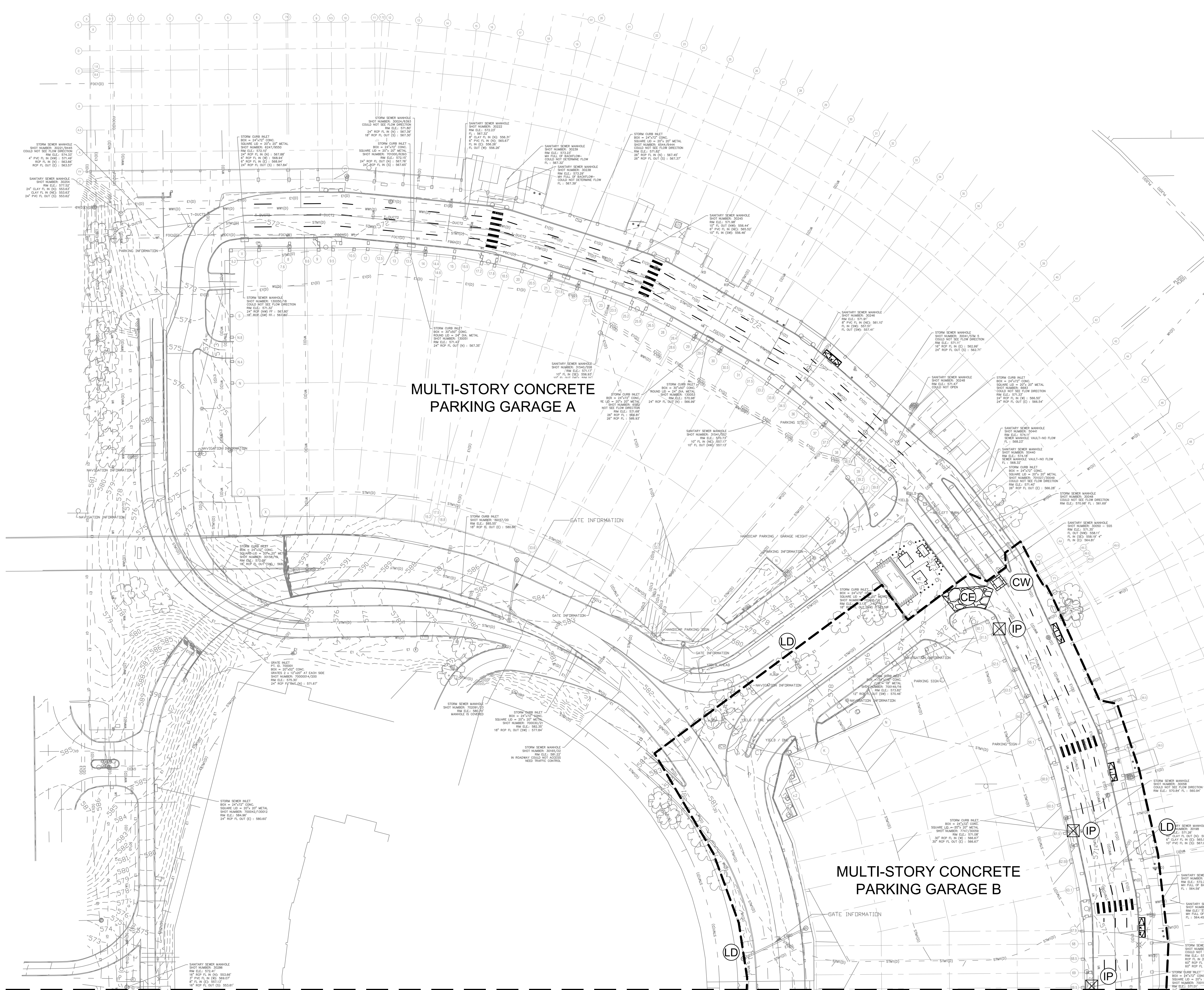

MULTI-STORY CONCRETE PARKING GARAGE A

MULTI-STORY CONCRETE PARKING GARAGE B

MATCHLINE - SEE SHEET CG103-900R

KEY PLAN

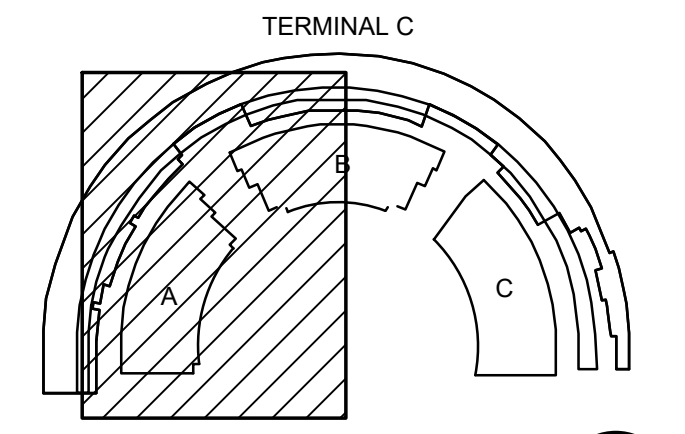

TERMINAL C GARAGE & ROADWAYS
EROSION CONTROL PLAN (PHASE 2)

SHEET NUMBER
CG102-900R

DFW DALLAS FORT WORTH INTERNATIONAL AIRPORT
2330 N INTERNATIONAL PARKWAY
DFW AIRPORT, TX 75261



h+k **Primera**
Primera Engineers, Ltd.
1300 West 74th
Suite 211
Columbus, TX 76801
+1 214 720 8800

DRAWN BY: SJP
APPROVED BY: JNA
ISSUE DATE: 2022-07-28
NOT FOR BID OR CONSTRUCTION

NO.	DATE	DESCRIPTION
0001-01-20	30% DESIGN	
0002-01-06	30% DESIGN	
0003-01-01	100% DESIGN	
0004-01-06	100% DESIGN FOR PERMIT (D/P)	

PROJECT NUMBER: TFD-007
PERMIT NUMBER: B22-0023
SCALE(S) AS NOTED ON THIS SHEET ARE BASED ON A FULL SIZE 30 X 42 SHEET.

BORDER RELEASE DATE: October 16, 2021
01/20/2021 14:59:09 C:\Users\h32222\OneDrive\Documents\HOX\DAL\DFW\Int\Airport - CTA Expansion Program\Project Files\01_CTA - Terminal C Garages and Roadways\CE\01 - CAD\Sheets\B22-0023-DFW-TC-CG102-900R-ErosionControl-Ph2.dwg

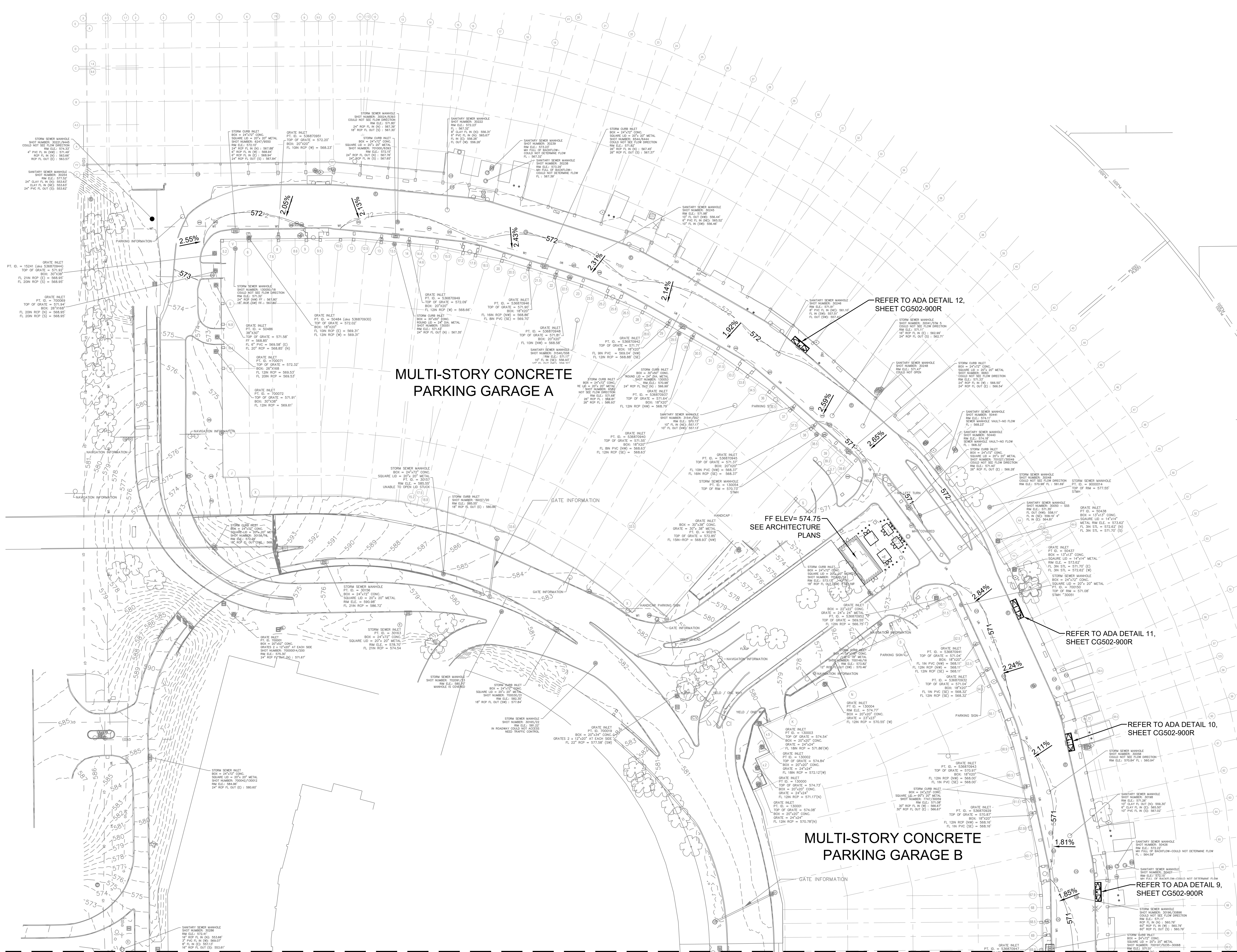
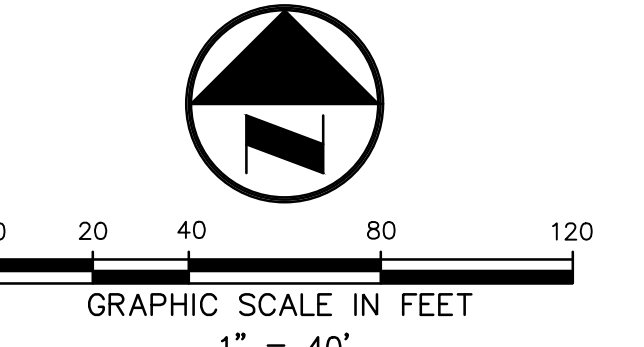

EXISTING LEGEND

- CRIADO CONTROL POINT
- IRON ROD FOUND
- BOLLARD
- GAS METER
- TRAFFIC SIGNAL LIGHT POLE
- TRAFFIC SIGNAL PULL BOX
- TRAFFIC SIGNAL CONTROL BOX
- TELECOM SERVICE BOX
- TELECOM PEDESTAL
- CATV PEDESTAL
- CATV JUNCTION BOX
- CATV APURTEANCE
- LIGHT POLE
- CATHODIC PROTECTION
- LIGHT POLE
- GENERIC MANHOLE
- POWER POLE
- GUYWIRE
- ELECTRIC MANHOLE
- ELECTRIC PULL BOX
- ELECTRIC METER
- ELECTRIC BOX
- ELECTRIC RISER
- GROUND LIGHT SIGN
- GAS PUMP
- FUEL TANK VENT
- TREE
- BUSH
- WASTE WATER CLEANOUT
- WASTE WATER MANHOLE
- STORM DRAIN MANHOLE
- WATER VALVE
- IRRIGATION CONTROL VALVE
- SPRINKLER HEAD
- SPIGOT
- FIRE HYDRANT
- WATER METER
- OVERHEAD UTILITY
- OVERHEAD ELECTRIC

GRADING LEGEND

- 570 --- EXISTING CONTOUR
- 570 — PROPOSED CONTOUR
- (R XXX.XX) RIM ELEVATION
- (TP XXX.XX) TOP OF PAVEMENT ELEVATION
- (TW XXX.XX) TOP OF WALL ELEVATION
- (TC XXX.XX) TOP OF CURB ELEVATION
- (FL XXX.XX) FLOW LINE ELEVATION
- RIDGE — RIDGE LINE
- 1.50% FLOW DIRECTION AND SLOPE

GRADING NOTES

1. CONTRACTOR TO VERIFY ALL EXISTING TOPOGRAPHY AND STRUCTURES ON THE SITE AND IMMEDIATELY NOTIFY THE ENGINEER OF ANY DISCREPANCIES PRIOR TO STARTING WORK.
2. ALL PAVEMENT SPOT GRADE ELEVATIONS AND RIM ELEVATIONS WITHIN OR ALONG CURB AND GUTTER REFER TO FLOW LINE ELEVATIONS UNLESS OTHERWISE NOTED.
3. ALL ELEVATIONS SHOWN DEPICT FINISHED GRADE UNLESS OTHERWISE NOTED. GENERAL CONTRACTOR TO COORDINATE WITH EXCAVATION, LANDSCAPE AND PAVING SUBCONTRACTORS REGARDING TOPSOIL THICKNESS FOR LANDSCAPE AREAS AND PAVEMENT SECTION THICKNESS FOR PAVED AREAS TO PROPERLY ENSURE ADEQUATE CUT TO ESTABLISH SUBGRADE ELEVATIONS.
4. NO EARTHEN SLOPE SHALL BE GREATER THAN 3:1, UNLESS OTHERWISE NOTED.
5. MAXIMUM SLOPE IN ACCESSIBLE PARKING SPACES AND LOADING ZONES SHALL NOT EXCEED 2.0% IN ALL DIRECTIONS.
6. MAXIMUM RUNNING SLOPE SHALL NOT EXCEED 5% AND CROSS SLOPE SHALL NOT EXCEED 2% ON ALL SIDEWALKS AND ACCESSIBLE ROUTES.
7. WHEN NATURAL FLOW OF DRAINAGE IS AWAY FROM CURB, CONTRACTOR TO INSTALL REVERSE GUTTER PITCH.
8. MATCH EXISTING ELEVATIONS AT PROJECT LIMITS.
9. STAIRS AND ADA RAMP FOR LOADING DOCK WILL BE PREFABRICATED PAINTED STEEL ELEMENTS TO FIT

KEY PLAN

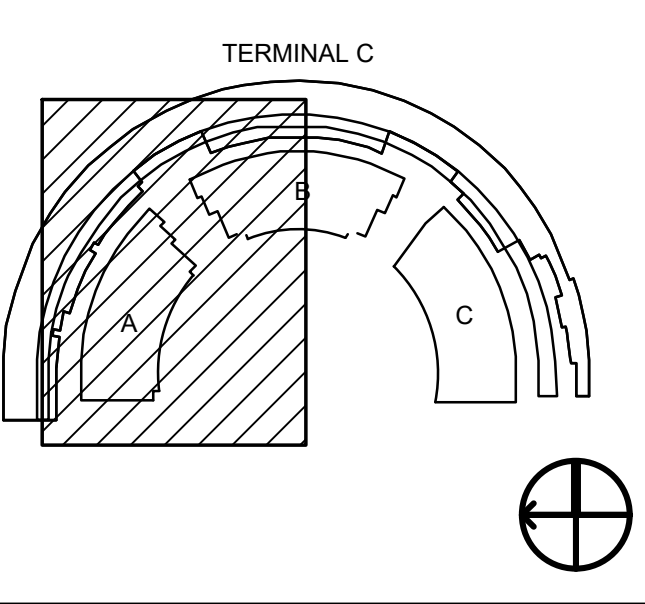

MATCHLINE - SEE SHEET CG106-900R

BORDER RELEASE DATE: October 16, 2021
01/20/2021 10:09:09 AM C:\Users\jrc23\Documents\HOV\DAL\DFW\Int'l Airport - CTA Expansion\Program\Project\Files\01_CTA - Terminal C Garages and Roadways\122396-Grading\Plan.dwg
C:\Users\jrc23\Documents\HOV\DAL\DFW\Int'l Airport - CTA Expansion\Program\Project\Files\01_CTA - Terminal C Garages and Roadways\122396-Grading\Plan.dwg

DFW DALLAS FORT WORTH INTERNATIONAL AIRPORT
2330 N INTERNATIONAL PARKWAY
DFW AIRPORT, TX 75261



h+k **Primera**
Hobbs, Chas & Kasebaum, Inc.
777 South Main Street
Suite 200, LB #
Dallas, TX 75201
+1 214 720 8000

Primera Engineers, Ltd.
300 West Lake
Suite 211
Ovington, TX 75051
+1 512 606 0110

NO.	DATE	DESCRIPTION
2022-01-06	30% DESIGN	
2022-05-01	100% DESIGN	
2022-07-28	100% DESIGN FOR PERMIT (D/P)	

DRAWN BY: SJP
APPROVED BY: JMA
ISSUE DATE: 2022-07-28
NOT FOR BID OR CONSTRUCTION

PROJECT NUMBER: TFD-007
TERMINAL C GARAGE & ROADWAYS
GRADING PLAN
PERMIT NUMBER: B22-0023

SHEET NUMBER
CG105-900R

SCALE(S) AS NOTED ON THIS SHEET ARE BASED ON A FULL SIZE 30 X 42 SHEET.

MULTI-STORY CONCRETE PARKING GARAGE B

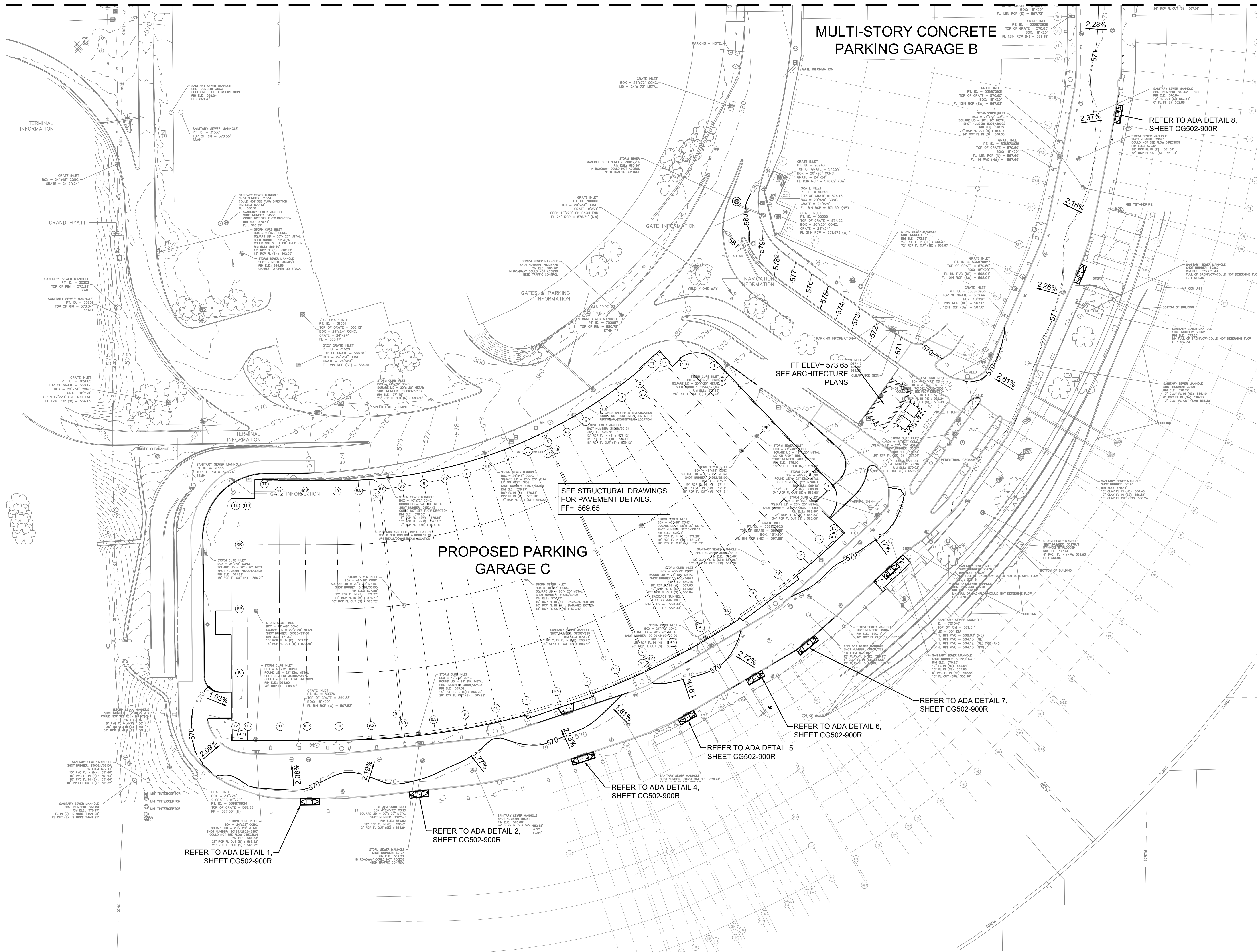
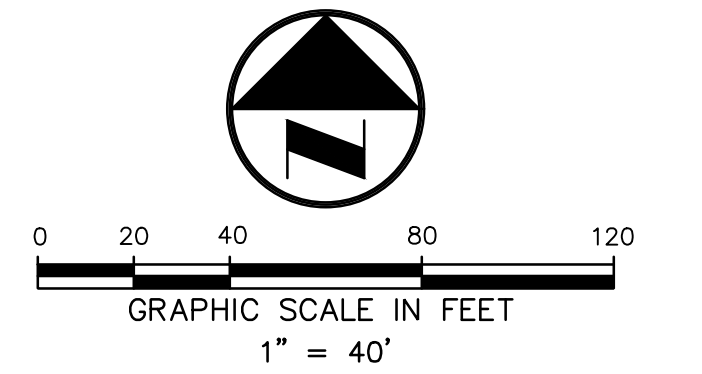

EXISTING LEGEND

- List of symbols for existing features: CRIADO CONTROL POINT, IRON ROD FOUND, BOLLARD, GAS METER, TRAFFIC SIGNAL LIGHT, POLE, TRAFFIC SIGNAL PULL BOX, TRAFFIC SIGNAL CONTROL BOX, TELECOM SERVICE BOX, TELECOM PEDESTAL, CATV PEDESTAL, CATV JUNCTION BOX, CATV APPURTENANCE, CATHODIC PROTECTION, FLAG POLE, GENERIC MANHOLE, POWER POLE, GUYWIRE, ELECTRIC MANHOLE, ELECTRIC PULL BOX, ELECTRIC METER, ELECTRIC BOX, ELECTRIC RISER, GROUND LIGHT SIGN, GAS PUMP, FUEL TANK VENT, TREE, BUSH, WASTE WATER CLEANOUT, WASTE WATER MANHOLE, STORM DRAIN MANHOLE, WATER VALVE, IRRIGATION CONTROL VALVE, SPRINKLER HEAD, SPIGOT, FIRE HYDRANT, WATER METER, OVERHEAD UTILITY, OVERHEAD ELECTRIC.

GRADING LEGEND

- List of symbols for grading features: EXISTING CONTOUR (dashed line), PROPOSED CONTOUR (solid line), RIM ELEVATION (R XXX.XX), TOP OF PAVEMENT ELEVATION (TP XXX.XX), TOP OF WALL ELEVATION (TW XXX.XX), TOP OF CURB ELEVATION (TC XXX.XX), FLOW LINE ELEVATION (FL XXX.XX), RIDGE LINE (RIDGE), FLOW DIRECTION AND SLOPE (1.50%).

GRADING NOTES

- 1. CONTRACTOR TO VERIFY ALL EXISTING TOPOGRAPHY AND STRUCTURES ON THE SITE AND IMMEDIATELY NOTIFY THE ENGINEER OF ANY DISCREPANCIES PRIOR TO STARTING WORK.
2. ALL PAVEMENT SPOT GRADE ELEVATIONS AND RIM ELEVATIONS WITHIN OR ALONG CURB AND GUTTER REFER TO FLOW LINE ELEVATIONS UNLESS OTHERWISE NOTED.
3. ALL ELEVATIONS SHOWN DEPICT FINISHED GRADE UNLESS OTHERWISE NOTED. GENERAL CONTRACTOR TO COORDINATE WITH EXCAVATION, LANDSCAPE AND PAVING SUBCONTRACTORS REGARDING TOPSOIL THICKNESS FOR LANDSCAPE AREAS AND PAVEMENT SECTION THICKNESS FOR PAVED AREAS TO PROPERLY ENSURE ADEQUATE CUT TO ESTABLISH SUBGRADE ELEVATIONS.
4. NO EARTHEN SLOPE SHALL BE GREATER THAN 3:1, UNLESS OTHERWISE NOTED.
5. MAXIMUM SLOPE IN ACCESSIBLE PARKING SPACES AND LOADING ZONES SHALL NOT EXCEED 2.0% IN ALL DIRECTIONS.
6. MAXIMUM RUNNING SLOPE SHALL NOT EXCEED 5% AND CROSS SLOPE SHALL NOT EXCEED 2% ON ALL SIDEWALKS AND ACCESSIBLE ROUTES.
7. WHEN NATURAL FLOW OF DRAINAGE IS AWAY FROM CURB, CONTRACTOR TO INSTALL REVERSE GUTTER PITCH.
8. MATCH EXISTING ELEVATIONS AT PROJECT LIMITS.
9. STAIRS AND ADA RAMP FOR LOADING DOCK WILL BE PREFABRICATED PAINTED STEEL ELEMENTS TO FIT

KEY PLAN

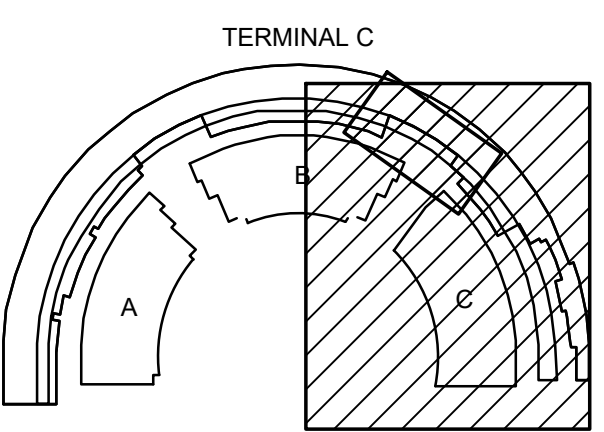

BORDER RELEASE DATE: October 16, 2021
01/20/2021 14:59:09
C:\Users\h32222\OneDrive\Documents\DFW-Terminal C Garages and Roadways\CG106-900R GradingPlan.dwg



DALLAS FORT WORTH INTERNATIONAL AIRPORT
2330 N INTERNATIONAL PARKWAY
DFW AIRPORT, TX 75261



h+k logo
Primera logo
Hobbs, Cook & Kasebaum, Inc.
777 North Meadows Drive
Suite 200, LB 8
Dallas, TX 75201
+1 214 720 8000
Primera Engineers, Ltd.
1300 Green Park
Suite 211
Ovington, TX 75051
+1 512 696 0910

Table with columns: NO., DATE, DESCRIPTION. Includes drawing and approval information.
NO. DATE DESCRIPTION
2022-01-06 30% DESIGN
2022-03-01 100% DESIGN
2022-07-28 100% DESIGN FOR PERMIT (DPR)
DRAWN BY: SJP
APPROVED BY: JMA
ISSUE DATE: 2022-07-28
NOT FOR BID OR CONSTRUCTION

PROJECT NUMBER: TFD-007
TERMINAL C GARAGE & ROADWAYS
GRADING PLAN
PERMIT NUMBER: B22-0023

SHEET NUMBER
CG106-900R

SCALE(S) AS NOTED ON THIS SHEET ARE BASED ON A FULL SIZE 30 X 42 SHEET.

DISCLAIMER: This document is provided for informational purposes only. It is not intended to be used as a substitute for professional engineering services. The user assumes all responsibility for the use of this information.

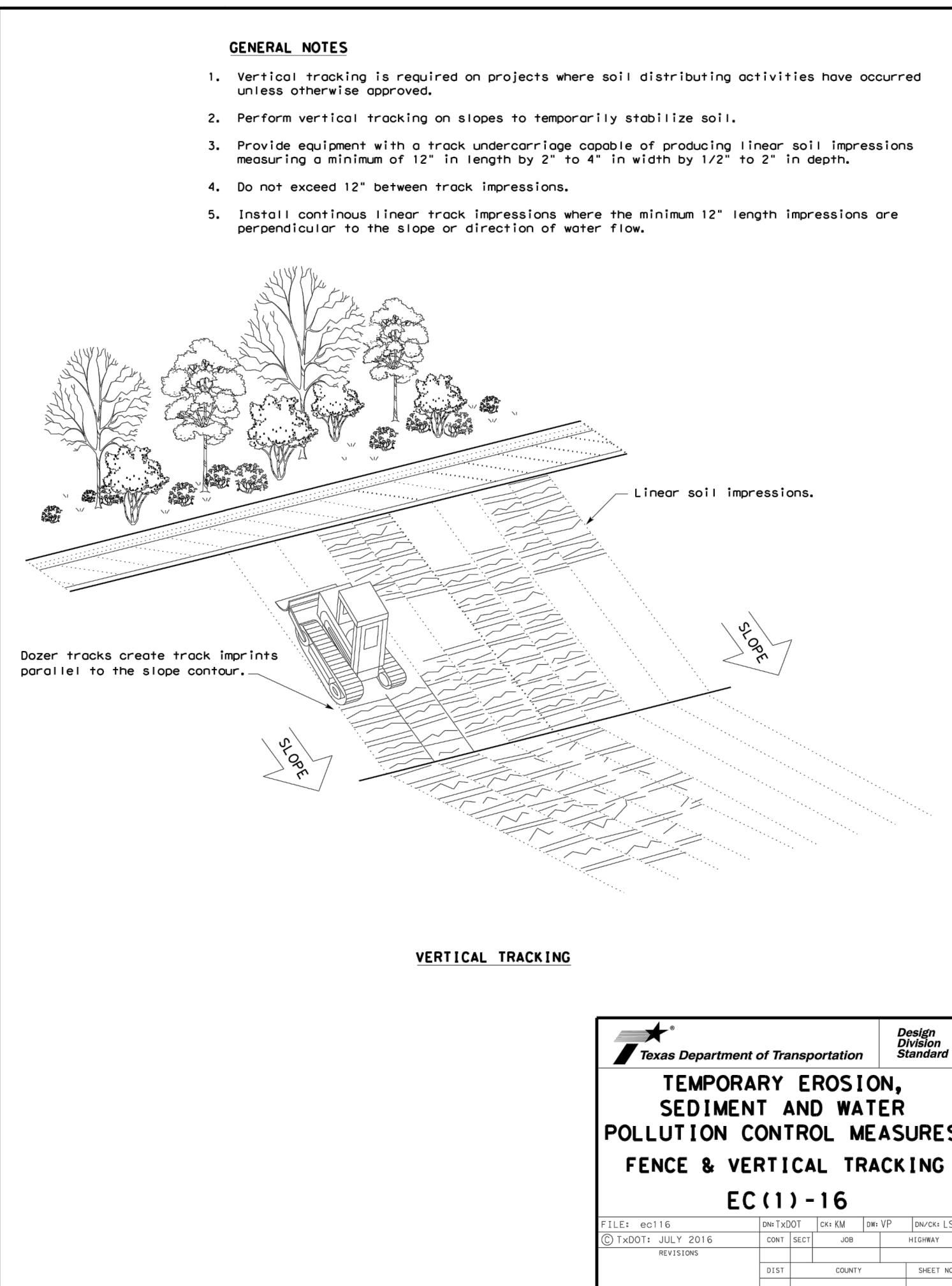
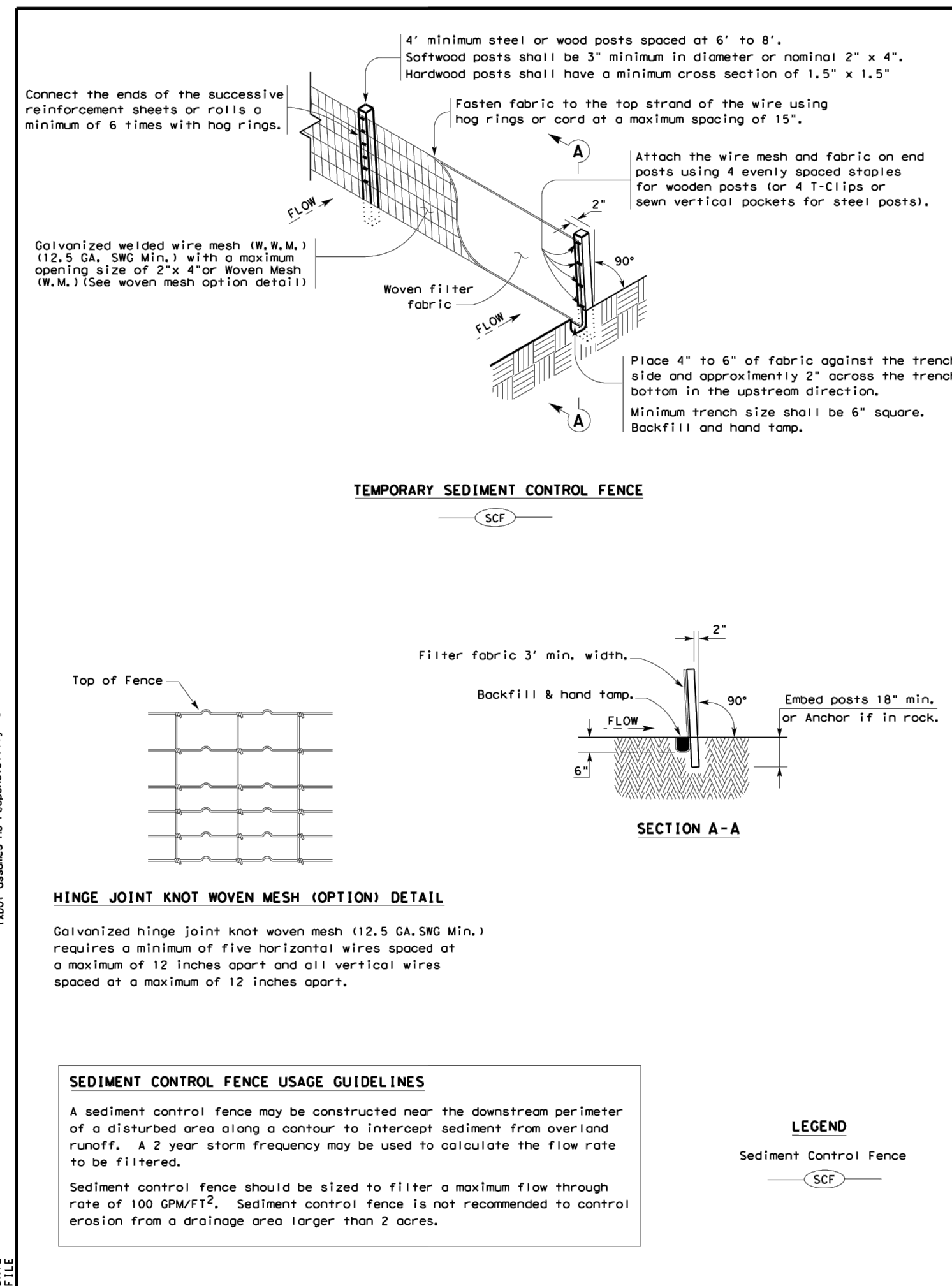

Texas Department of Transportation
Design Division
Standard

TEMPORARY EROSION, SEDIMENT AND WATER POLLUTION CONTROL MEASURES FENCE & VERTICAL TRACKING

EC (1) - 16

FILE: EC116
DATE: JULY 2016
REVISED: 08/2016

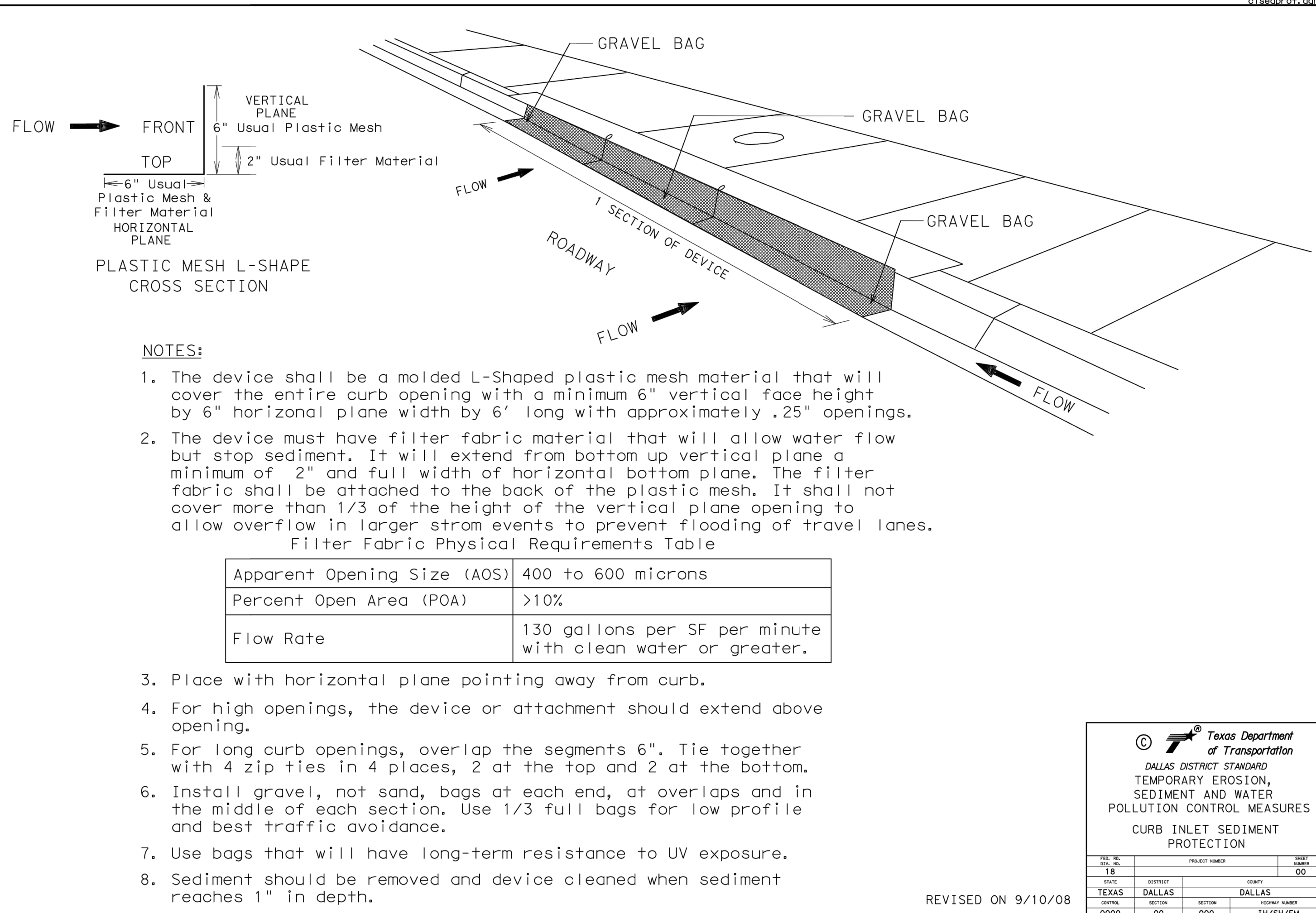

Texas Department of Transportation
DALLAS DISTRICT STANDARD
TEMPORARY EROSION, SEDIMENT AND WATER POLLUTION CONTROL MEASURES CURB INLET SEDIMENT PROTECTION

FILE: EC116
DATE: JULY 2016
REVISED: 08/2016

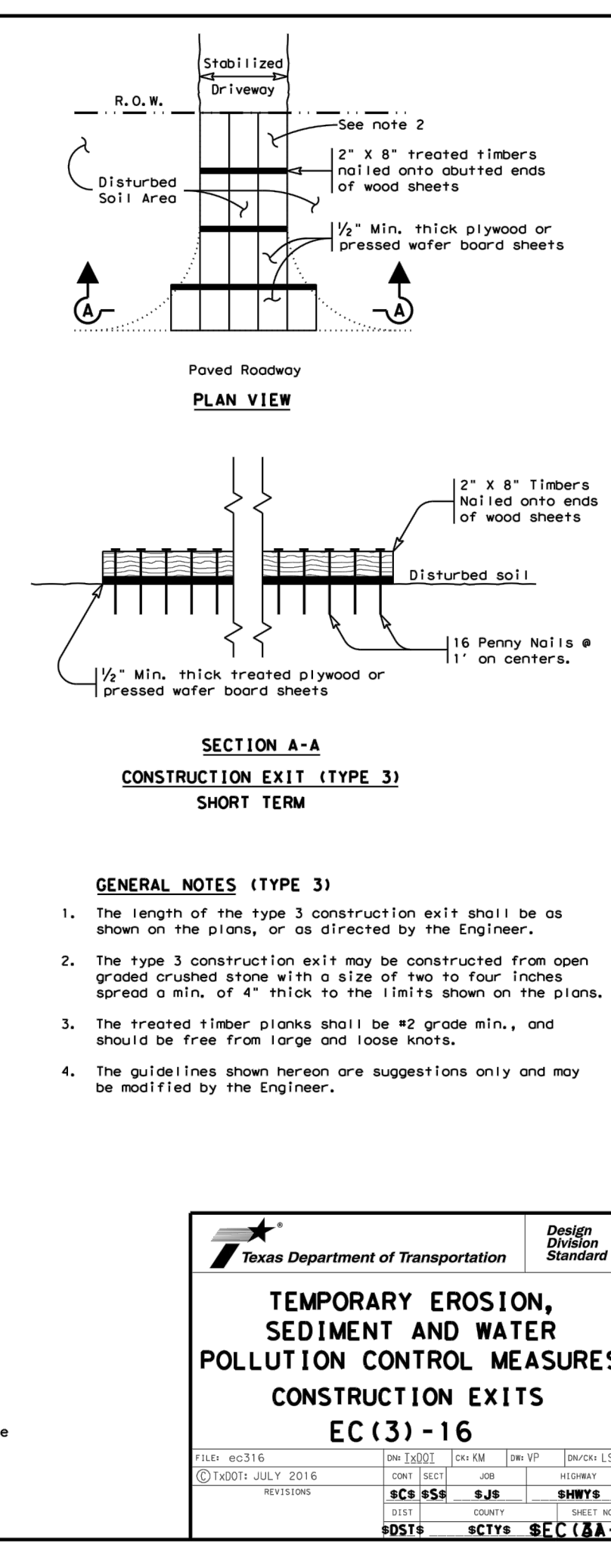
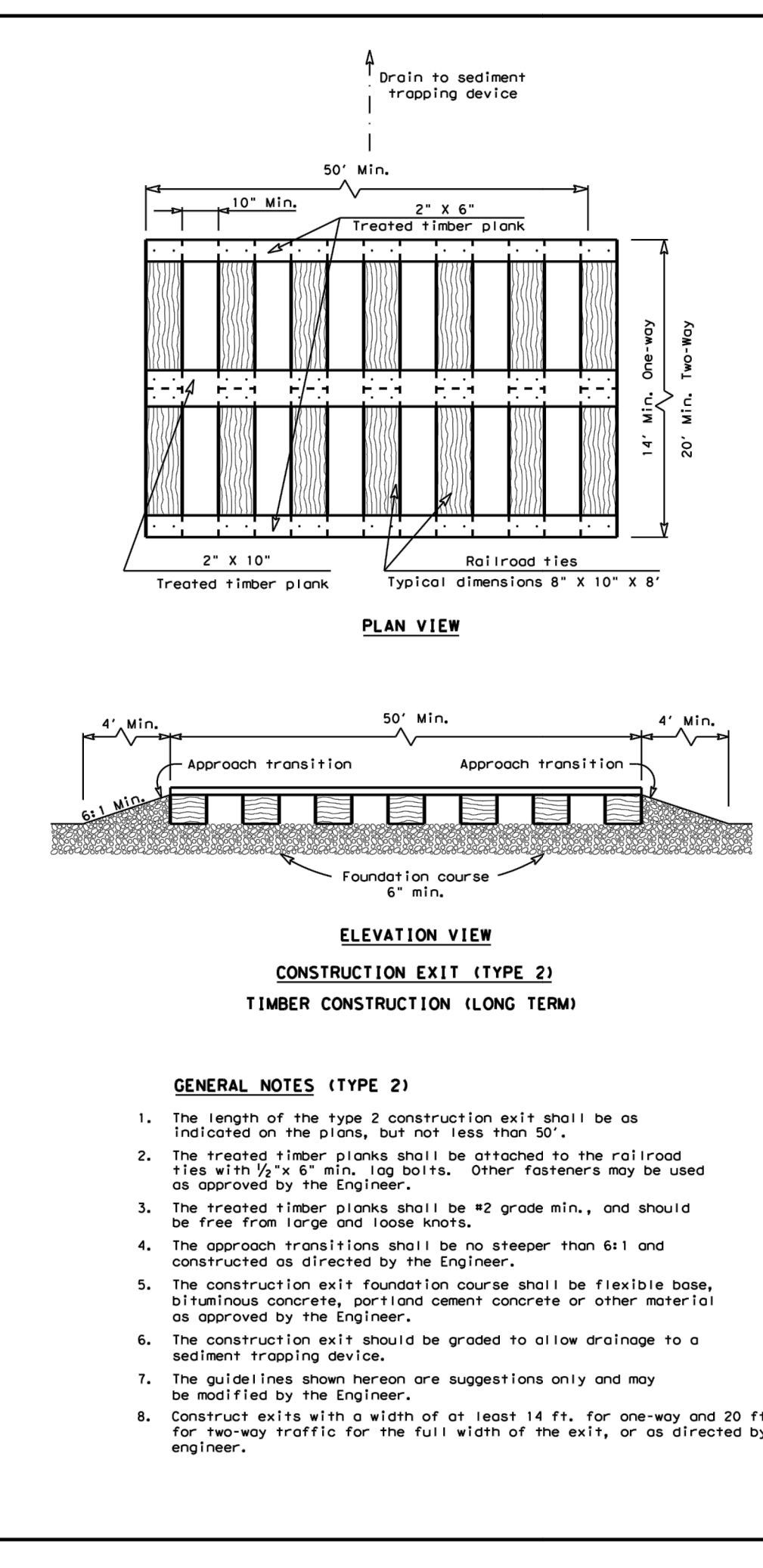
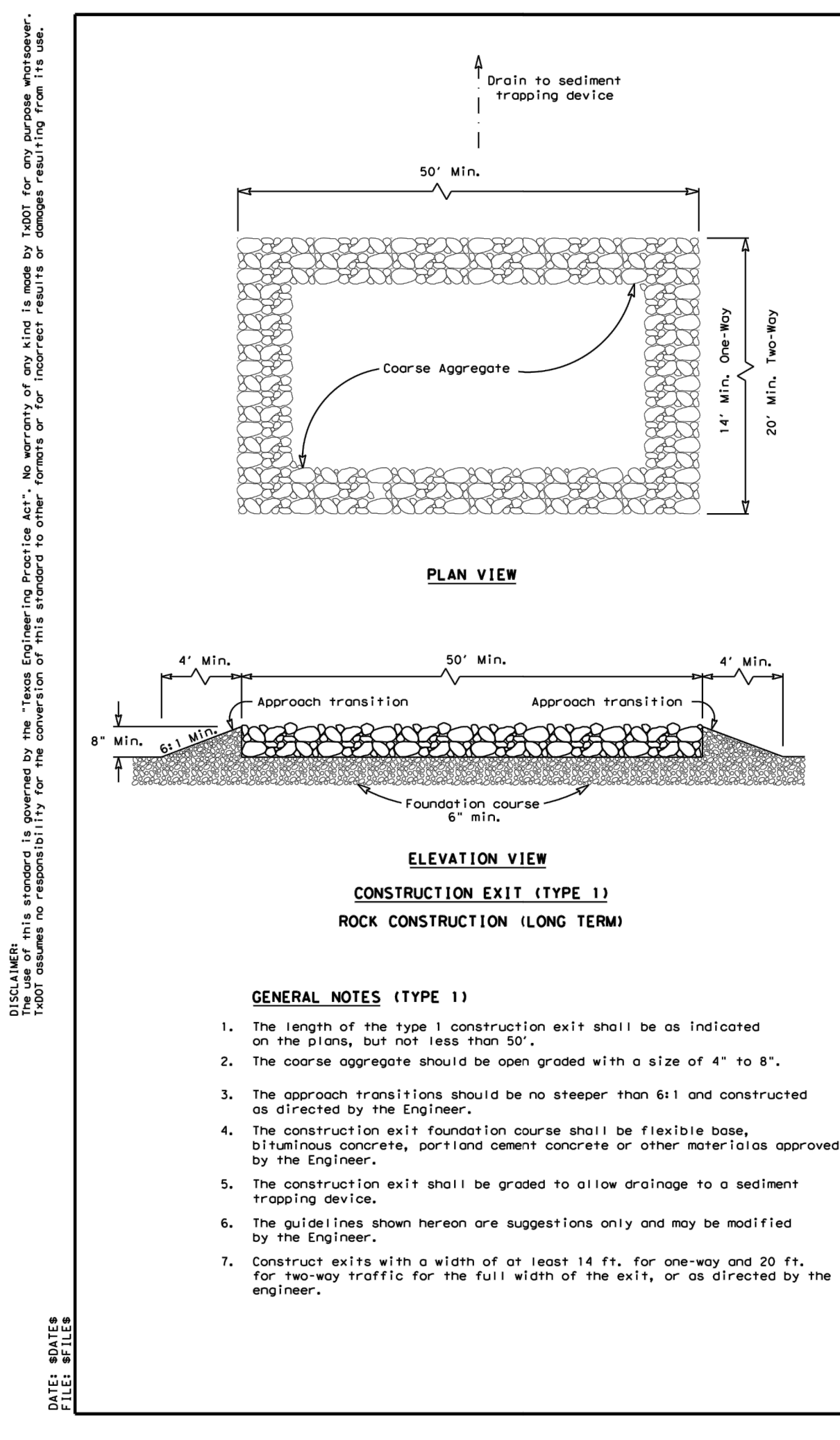

Texas Department of Transportation
Design Division
Standard

TEMPORARY EROSION, SEDIMENT AND WATER POLLUTION CONTROL MEASURES CONSTRUCTION EXITS

EC (3) - 16

FILE: EC316
DATE: JULY 2016
REVISED: 08/2016

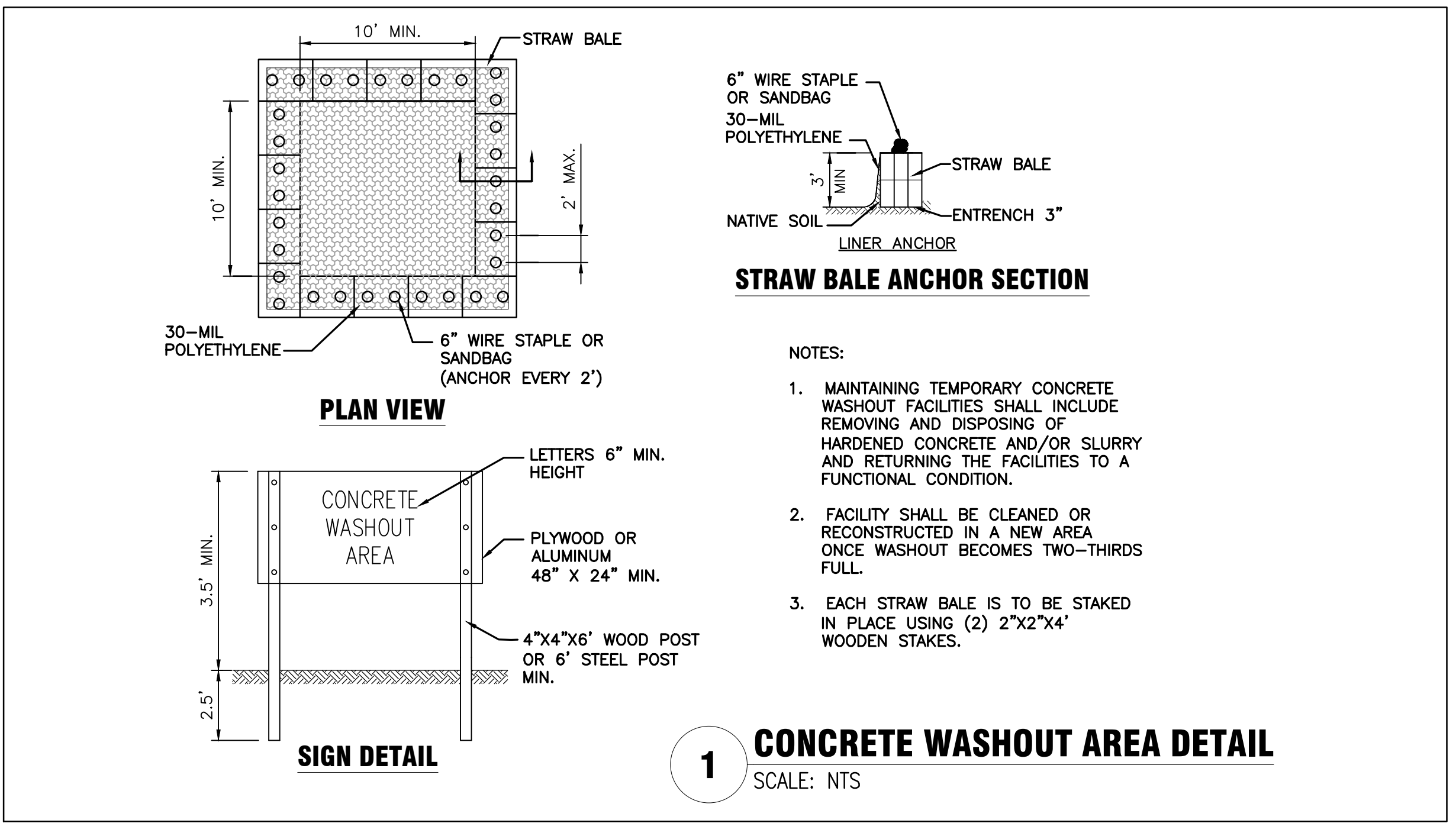

BORDER RELEASE DATE: October 16, 2021
 01/20/2021 14:09:09
 C:\Users\h32323232\Documents\DFW-TC-G554-0101-ErosionDetails.dwg

DFW DALLAS FORT WORTH INTERNATIONAL AIRPORT

2330 N INTERNATIONAL PARKWAY
DFW AIRPORT, TX 75261



h+k Primera

Primera Engineers, LLC
300 West Fair
Suite 200, L.B. #8
Dallas, TX 75201
+1 214 720 8800

DRAWN BY: SJP
APPROVED BY: JNA
ISSUE DATE: 2022-07-28

NOT FOR BID OR CONSTRUCTION

NO.	DATE	DESCRIPTION
2022-01-06	30% DESIGN	
2022-05-01	100% DESIGN	
2022-07-28	100% SUBMITTED FOR PERMIT (SFP)	

TERMINAL C GARAGE & ROADWAYS

EROSION CONTROL DETAILS

PROJECT NUMBER: TFD-007

PERMIT NUMBER: B22-0023

SHEET NUMBER
CG501-900R

SCALE(S) AS NOTED ON THIS SHEET ARE BASED ON A FULL SIZE 30 X 42 SHEET.

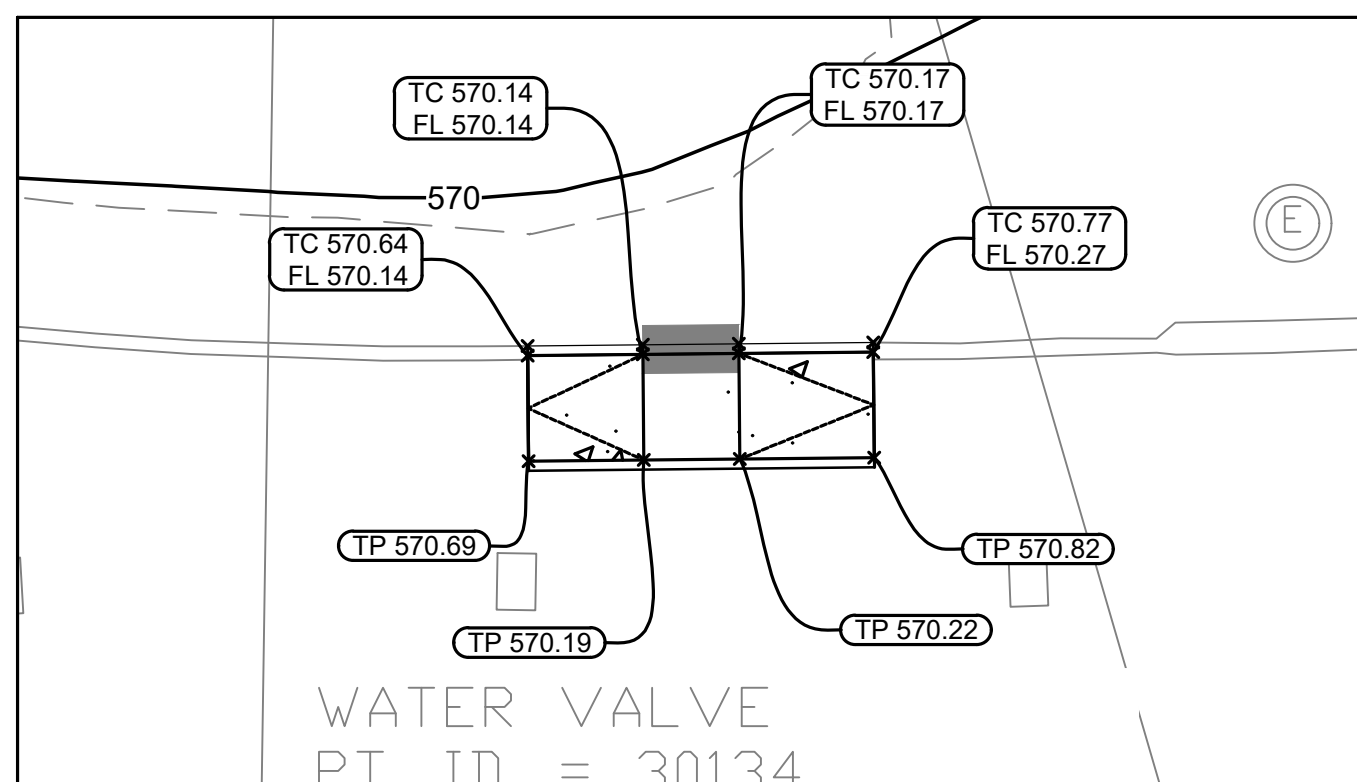

1 ADA DETAIL 1
1" = 10'

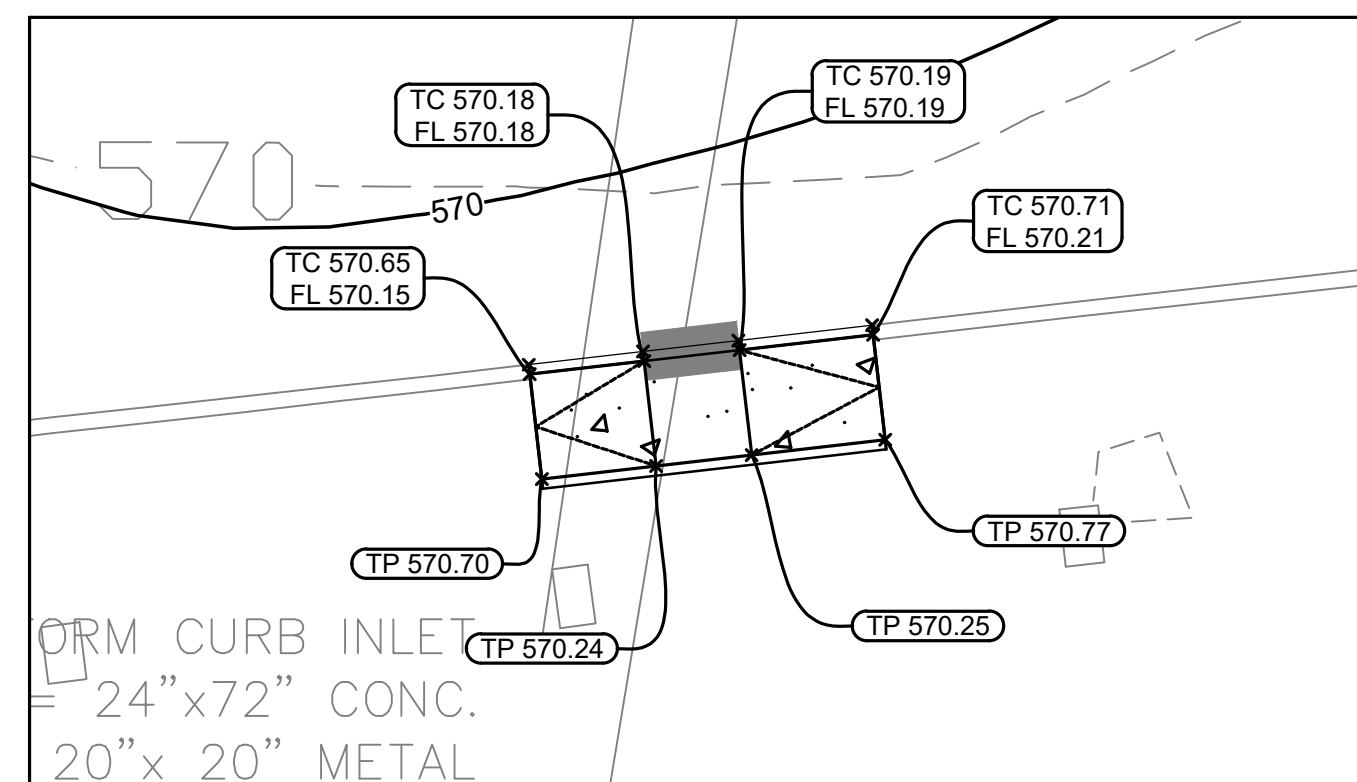

2 ADA DETAIL 2
1" = 10'

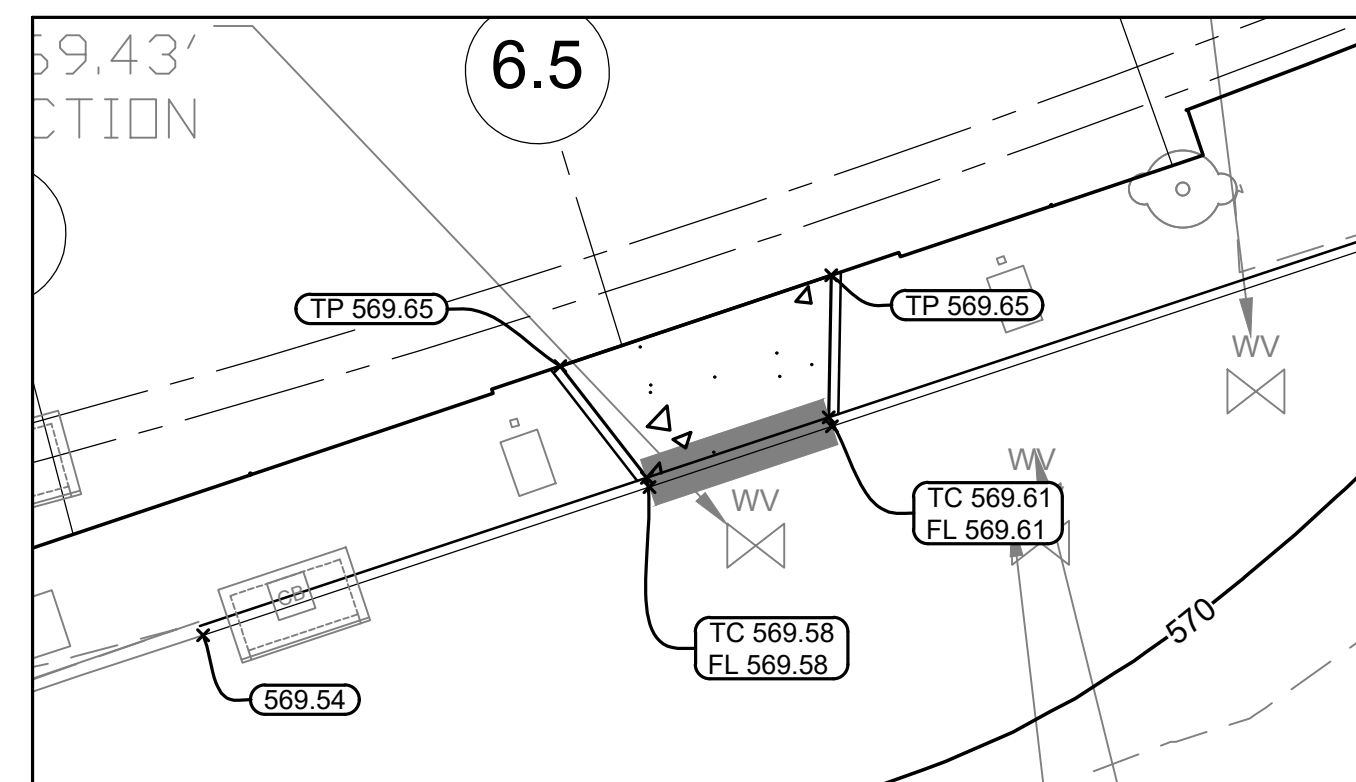

3 ADA DETAIL 3
1" = 10'

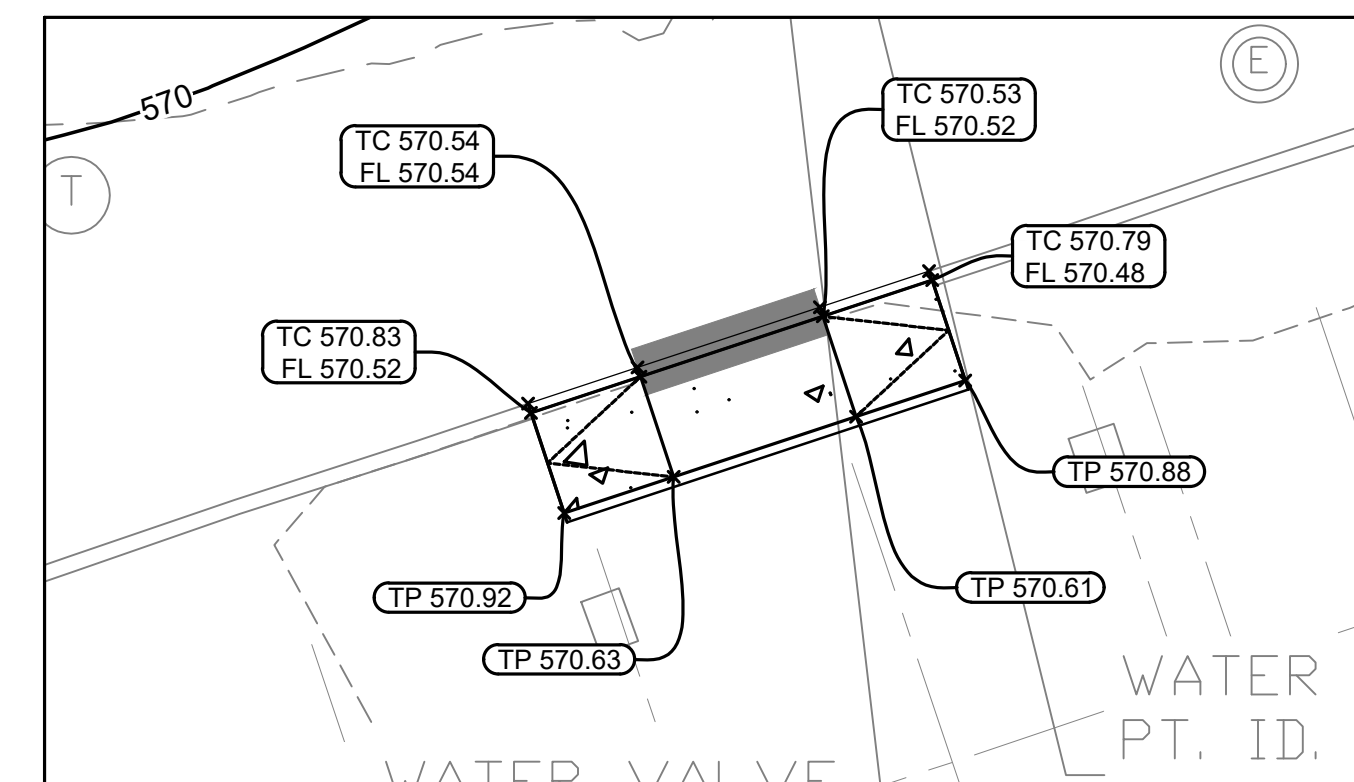

4 ADA DETAIL 4
1" = 10'

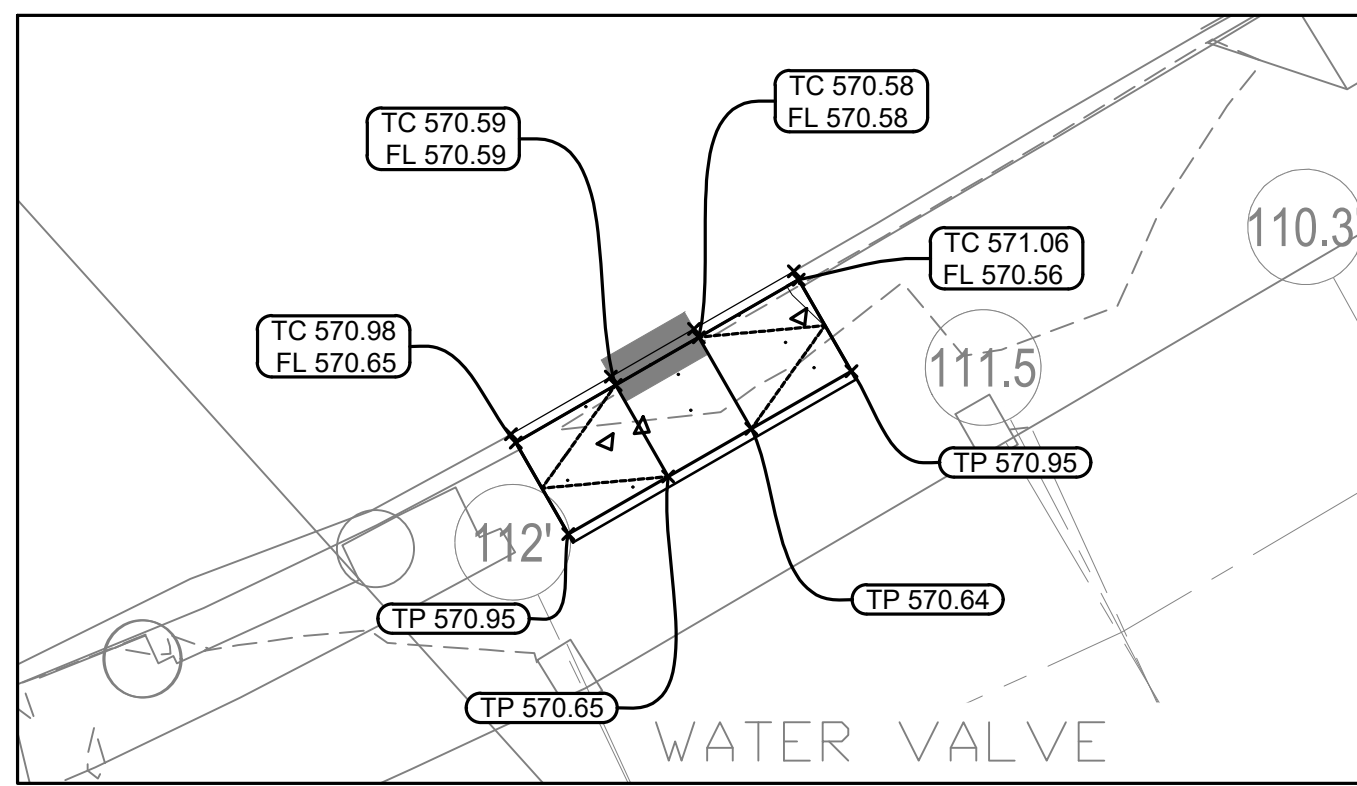

5 ADA DETAIL 5
1" = 10'

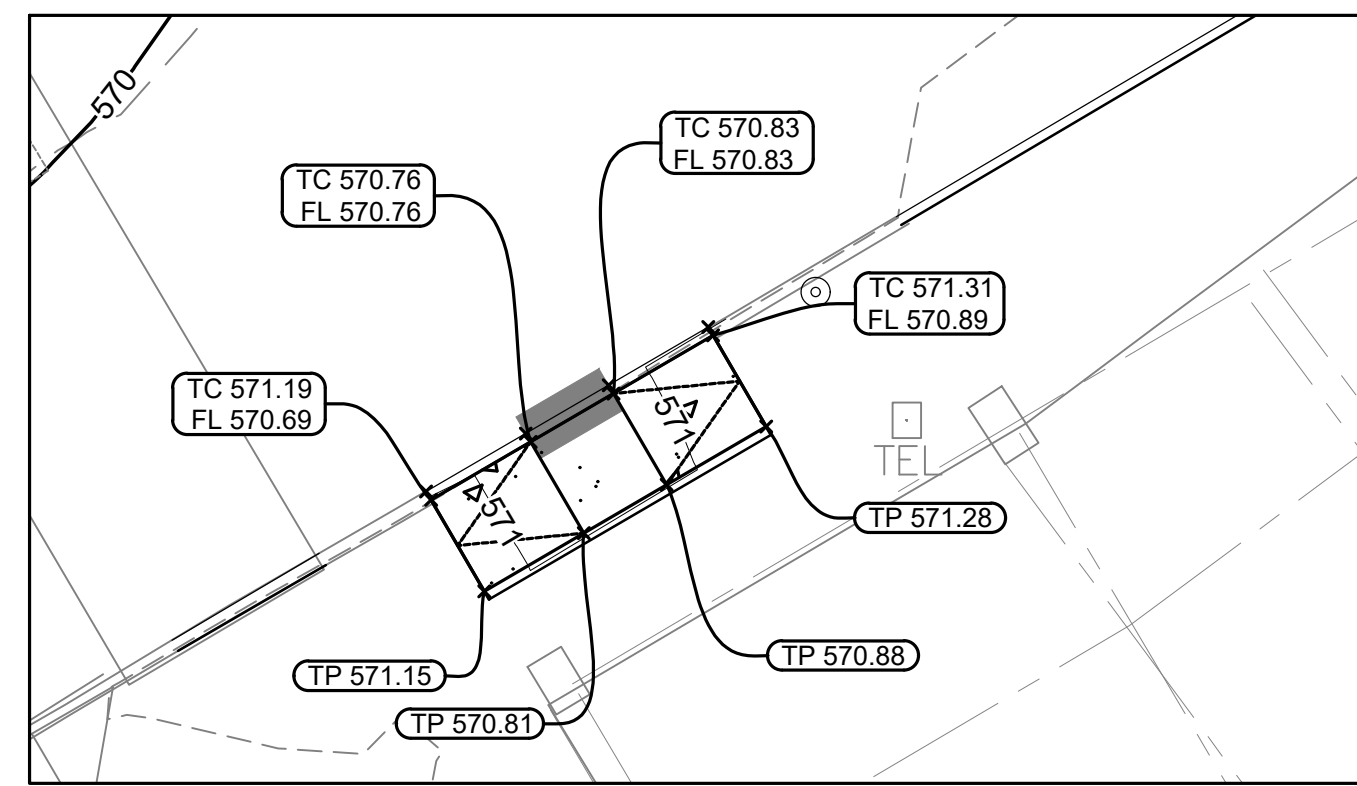

6 ADA DETAIL 6
1" = 10'

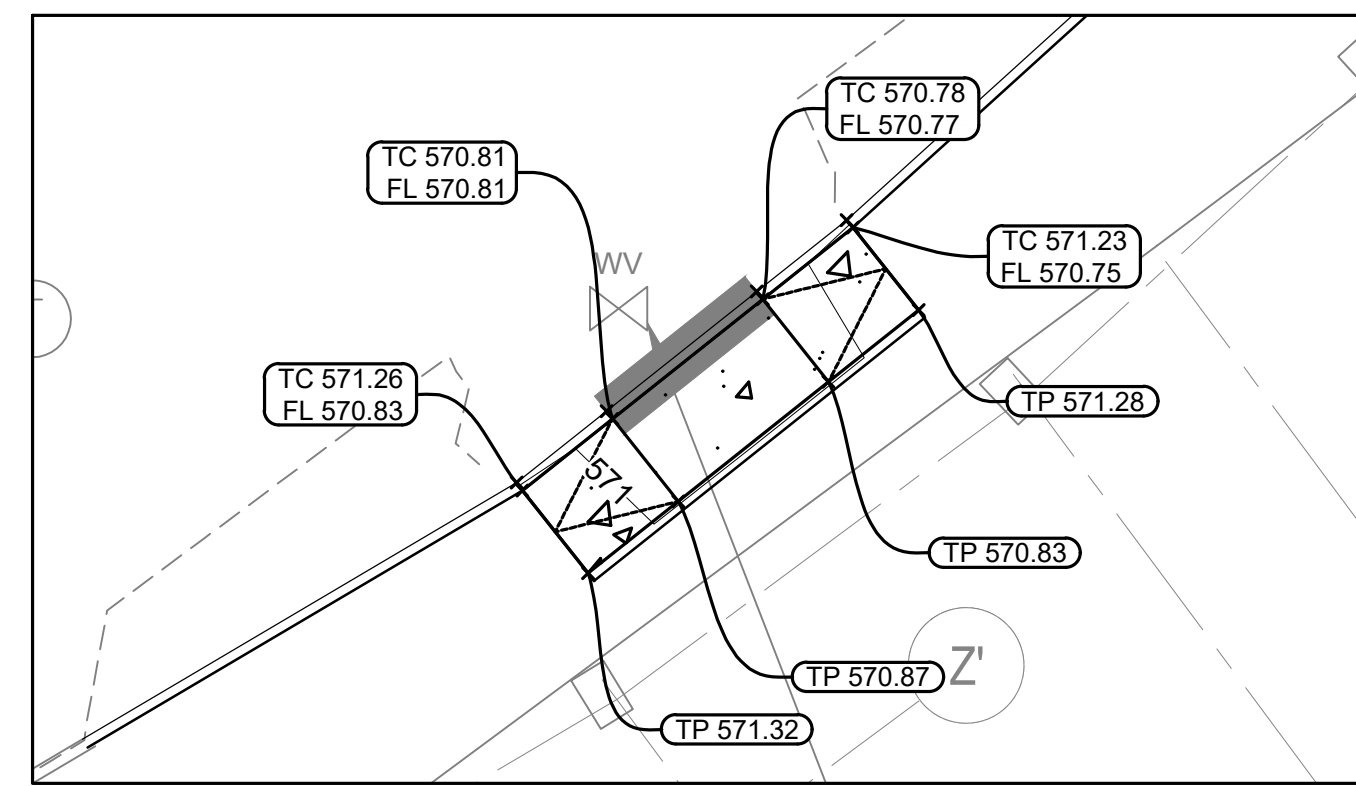

7 ADA DETAIL 7
1" = 10'

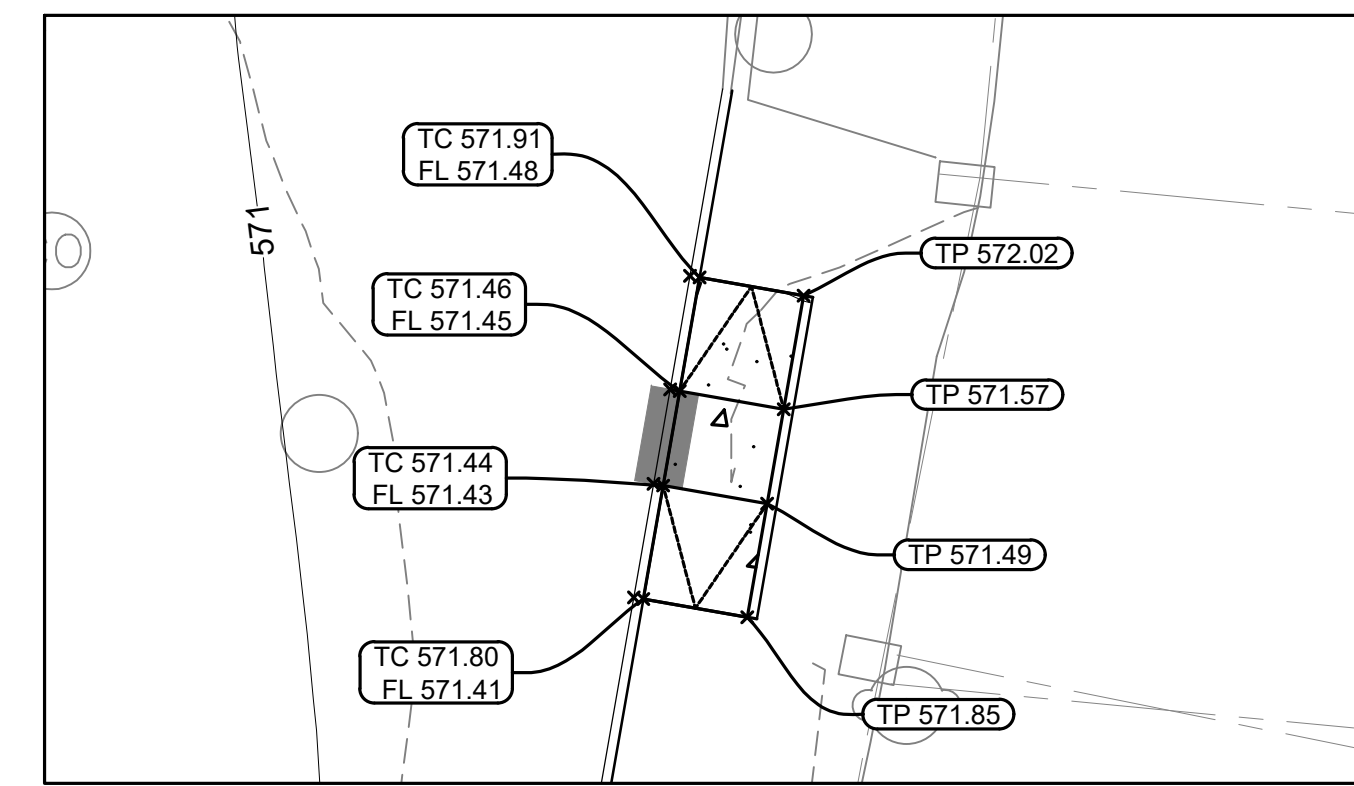

8 ADA DETAIL 8
1" = 10'

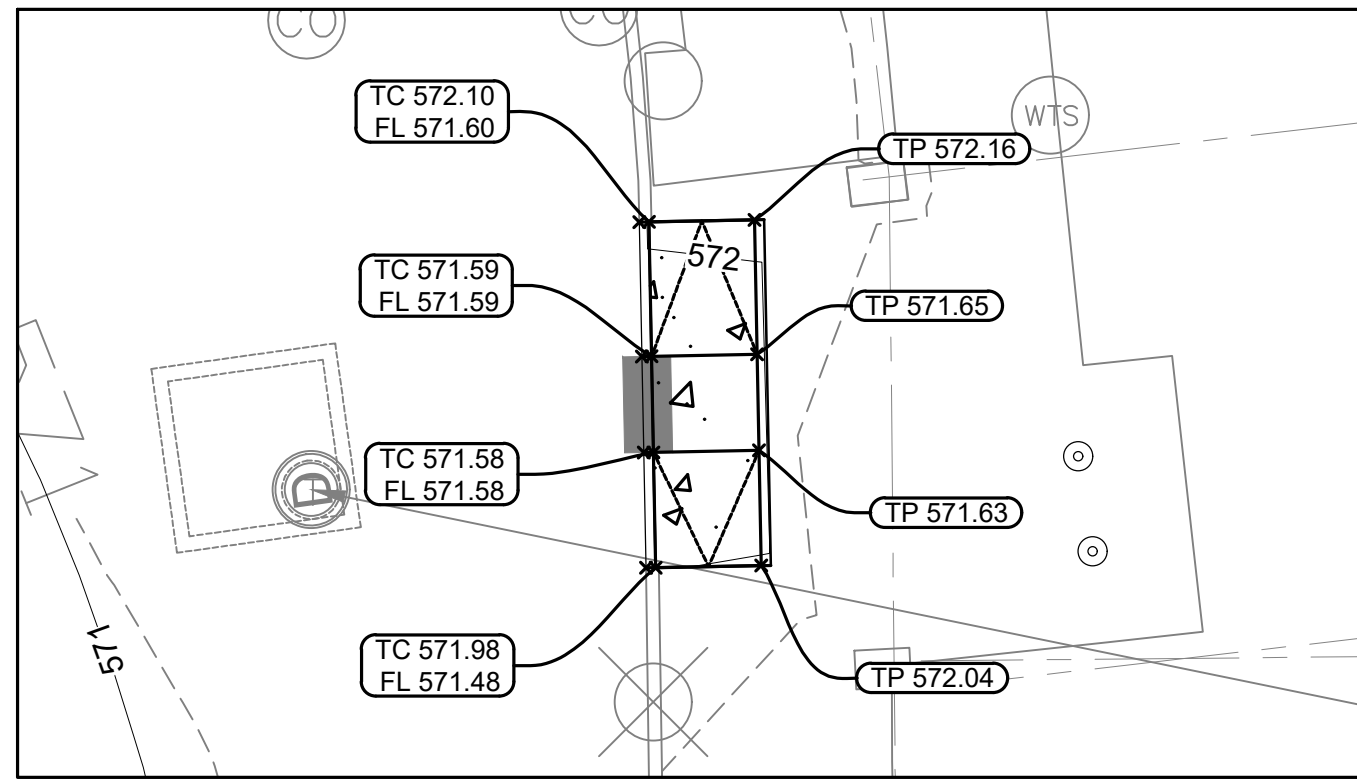

9 ADA DETAIL 9
1" = 10'

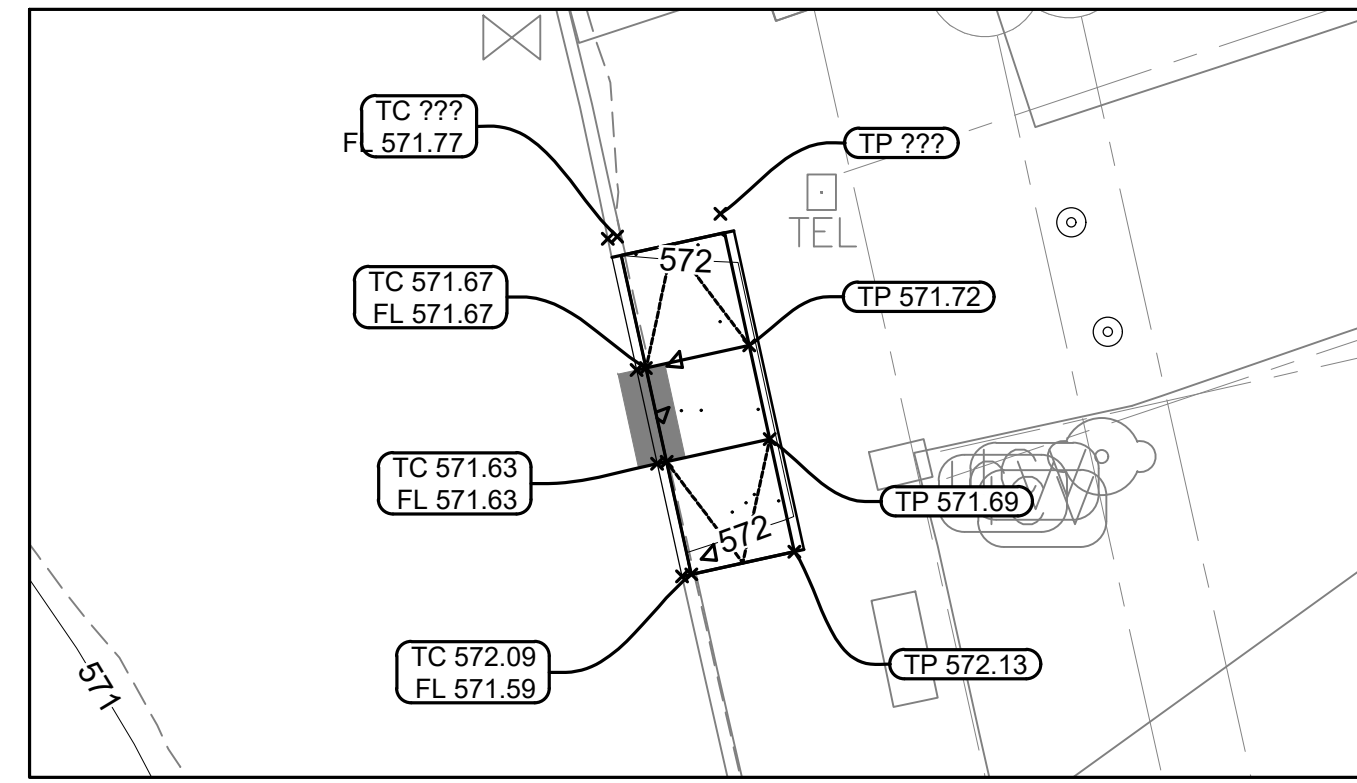

10 ADA DETAIL 10
1" = 10'

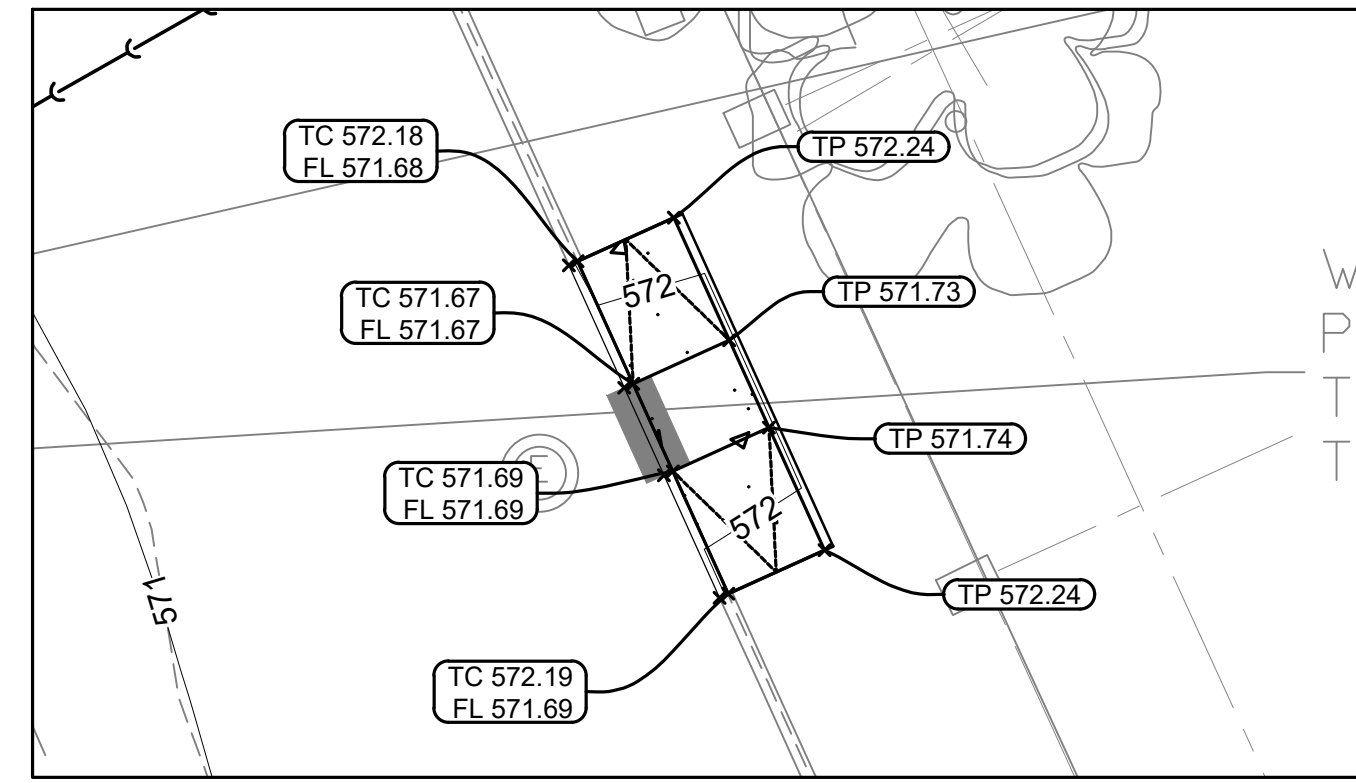

11 ADA DETAIL 11
1" = 10'

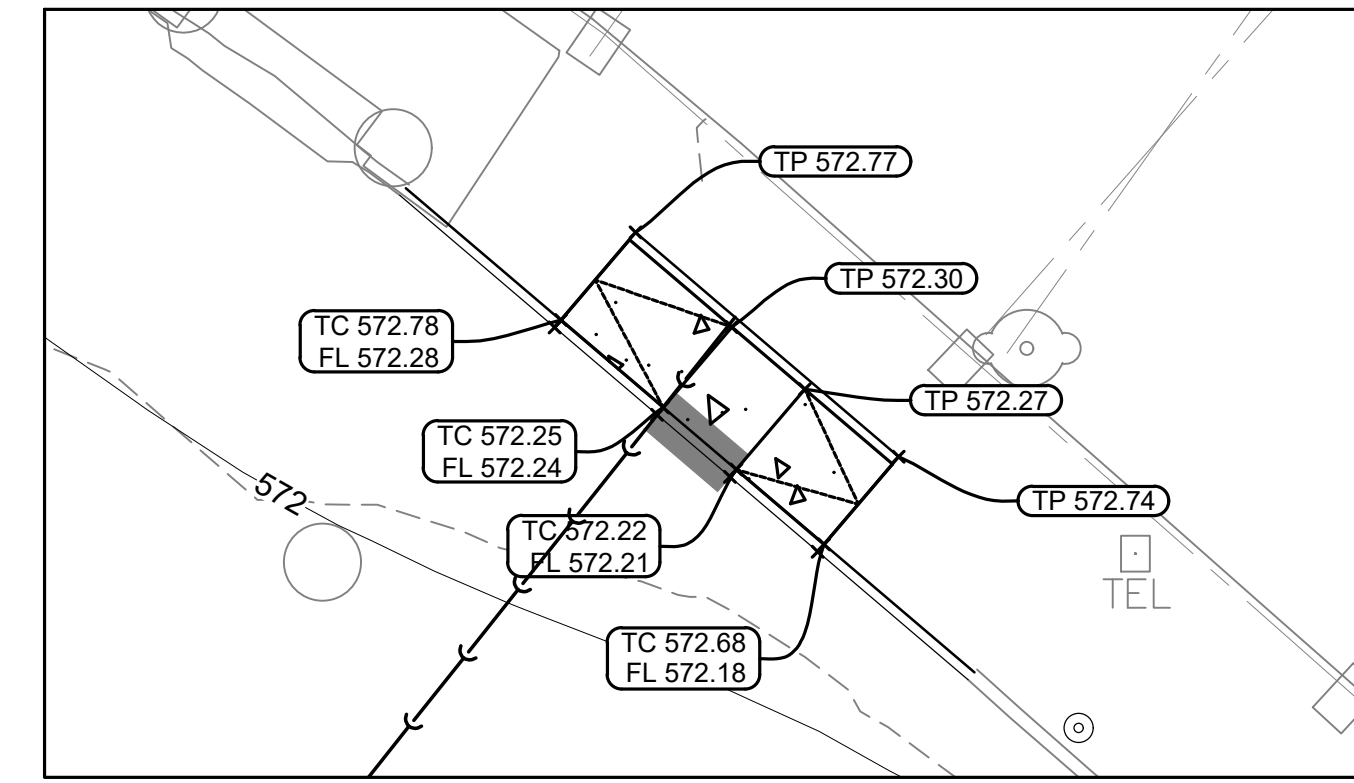

12 ADA DETAIL 12
1" = 10'

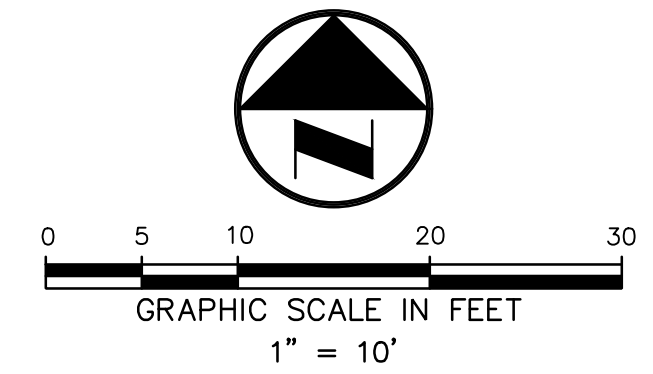

EXISTING LEGEND

- CRIADO CONTROL POINT
- IRON ROD FOUND
- BOLLARD
- GAS METER
- TRAFFIC SIGNAL LIGHT POLE
- TRAFFIC SIGNAL PULL BOX
- TRAFFIC SIGNAL CONTROL BOX
- TELECOM SERVICE BOX
- TELECOM PEDESTAL
- CATV PEDESTAL
- CATV JUNCTION BOX
- CATV APPURTENANCE
- LIGHT POLE
- CATHODIC PROTECTION FLAG POLE
- GENERIC MANHOLE
- POWER POLE
- GUYWIRE
- ELECTRIC MANHOLE
- ELECTRIC PULL BOX
- ELECTRIC METER
- ELECTRIC BOX
- ELECTRIC RISER
- GROUND LIGHT SIGN
- GAS PUMP
- FUEL TANK VENT
- BUSH
- WASTE WATER CLEANOUT
- WASTE WATER MANHOLE
- STORM DRAIN MANHOLE
- WATER VALVE
- IRRIGATION CONTROL VALVE
- SPRINKLER HEAD
- SPIGOT
- FIRE HYDRANT
- WATER METER
- OVERHEAD UTILITY
- OVERHEAD ELECTRIC

GRADING LEGEND

- 570 --- EXISTING CONTOUR
- 570 — PROPOSED CONTOUR
- (R XXX.XX) RIM ELEVATION
- (TP XXX.XX) TOP OF PAVEMENT ELEVATION
- (TW XXX.XX) TOP OF WALL ELEVATION
- (TC XXX.XX / FL XXX.XX) TOP OF CURB ELEVATION / FLOW LINE ELEVATION
- RIDGE — RIDGE LINE
- 1.50% FLOW DIRECTION AND SLOPE

GRADING NOTES

1. CONTRACTOR TO VERIFY ALL EXISTING TOPOGRAPHY AND STRUCTURES ON THE SITE AND IMMEDIATELY NOTIFY THE ENGINEER OF ANY DISCREPANCIES PRIOR TO STARTING WORK.
2. ALL PAVEMENT SPOT GRADE ELEVATIONS AND RIM ELEVATIONS WITHIN OR ALONG CURB AND GUTTER REFER TO FLOW LINE ELEVATIONS UNLESS OTHERWISE NOTED.
3. ALL ELEVATIONS SHOWN DEPICT FINISHED GRADE UNLESS OTHERWISE NOTED. GENERAL CONTRACTOR TO COORDINATE WITH EXCAVATION, LANDSCAPE AND PAVING SUBCONTRACTORS REGARDING TOPSOIL THICKNESS FOR LANDSCAPE AREAS AND PAVEMENT SECTION THICKNESS FOR PAVED AREAS TO PROPERLY ENSURE ADEQUATE CUT TO ESTABLISH SUBGRADE ELEVATIONS.
4. NO EARTHEN SLOPE SHALL BE GREATER THAN 3:1, UNLESS OTHERWISE NOTED.
5. MAXIMUM SLOPE IN ACCESSIBLE PARKING SPACES AND LOADING ZONES SHALL NOT EXCEED 2.0% IN ALL DIRECTIONS.
6. MAXIMUM RUNNING SLOPE SHALL NOT EXCEED 5% AND CROSS SLOPE SHALL NOT EXCEED 2% ON ALL SIDEWALKS AND ACCESSIBLE ROUTES.
7. WHEN NATURAL FLOW OF DRAINAGE IS AWAY FROM CURB, CONTRACTOR TO INSTALL REVERSE GUTTER PITCH.
8. MATCH EXISTING ELEVATIONS AT PROJECT LIMITS.
9. STAIRS AND ADA RAMP FOR LOADING DOCK WILL BE PREFABRICATED PAINTED STEEL ELEMENTS TO FIT THE AT LOCATIONS SHOWN. RAMP IS TO COMPLY WITH ADA REQUIREMENTS. RAMP IS TO BE FABRICATED SO ELEMENTS CAN BE BOLTED TOGETHER IN THE FIELD. CONTRACTOR TO PROVIDE SHOP DRAWINGS FOR REVIEW.

BORDER RELEASE DATE: October 16, 2021
01/20/2021 10:50:09 AM C:\Users\jmc2020\OneDrive\Documents\CG502-900R-Detail\CG502-900R-Detail.dwg
C:\Users\jmc2020\OneDrive\Documents\CG502-900R-Detail\CG502-900R-Detail.dwg

DALLAS
FORT WORTH
INTERNATIONAL
AIRPORT

2330 N INTERNATIONAL PARKWAY
DFW AIRPORT, TX 75261



Primera

Primera Engineers, Ltd.
300 West 7th
Suite 211
Dallas, TX 75201
+1 214 720 8800

DRAWN BY: SJP
APPROVED BY: JMA
ISSUE DATE: 2022-07-28

NOT FOR BID OR CONSTRUCTION

NO.	DATE	DESCRIPTION
2022-07-28	30% DESIGN	
2022-01-06	30% DESIGN	
2022-01-06	100% DESIGN	
2022-07-28	100% DESIGN FOR PERMIT (DPP)	

TERMINAL C GARAGE & ROADWAYS

GRADING DETAILS (LOWER ROADWAY)

PROJECT NUMBER: TFD-007

PERMIT NUMBER: B22-0023

SHEET NUMBER

CG502-900R

SCALE(S) AS NOTED ON THIS SHEET ARE BASED ON A FULL SIZE 30 X 42 SHEET.

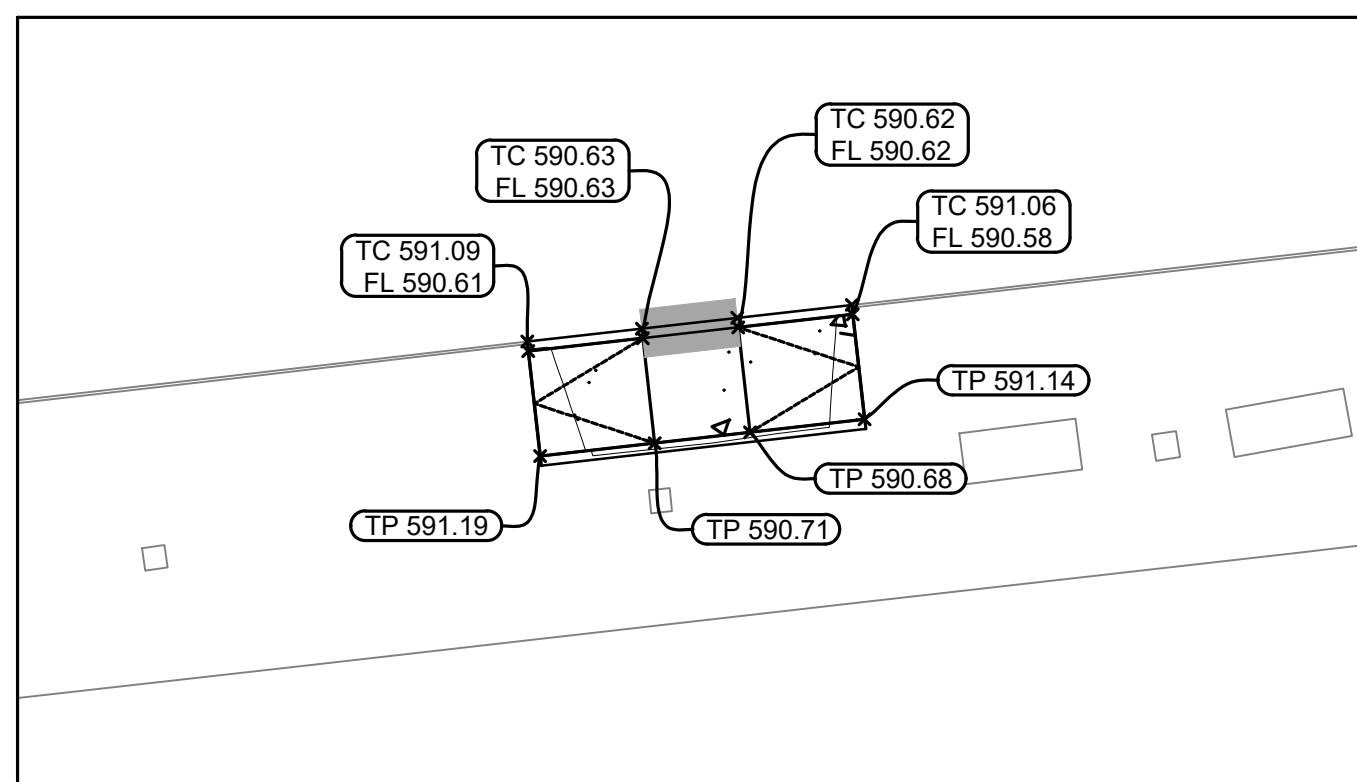

14 ADA DETAIL 14
1" = 10'

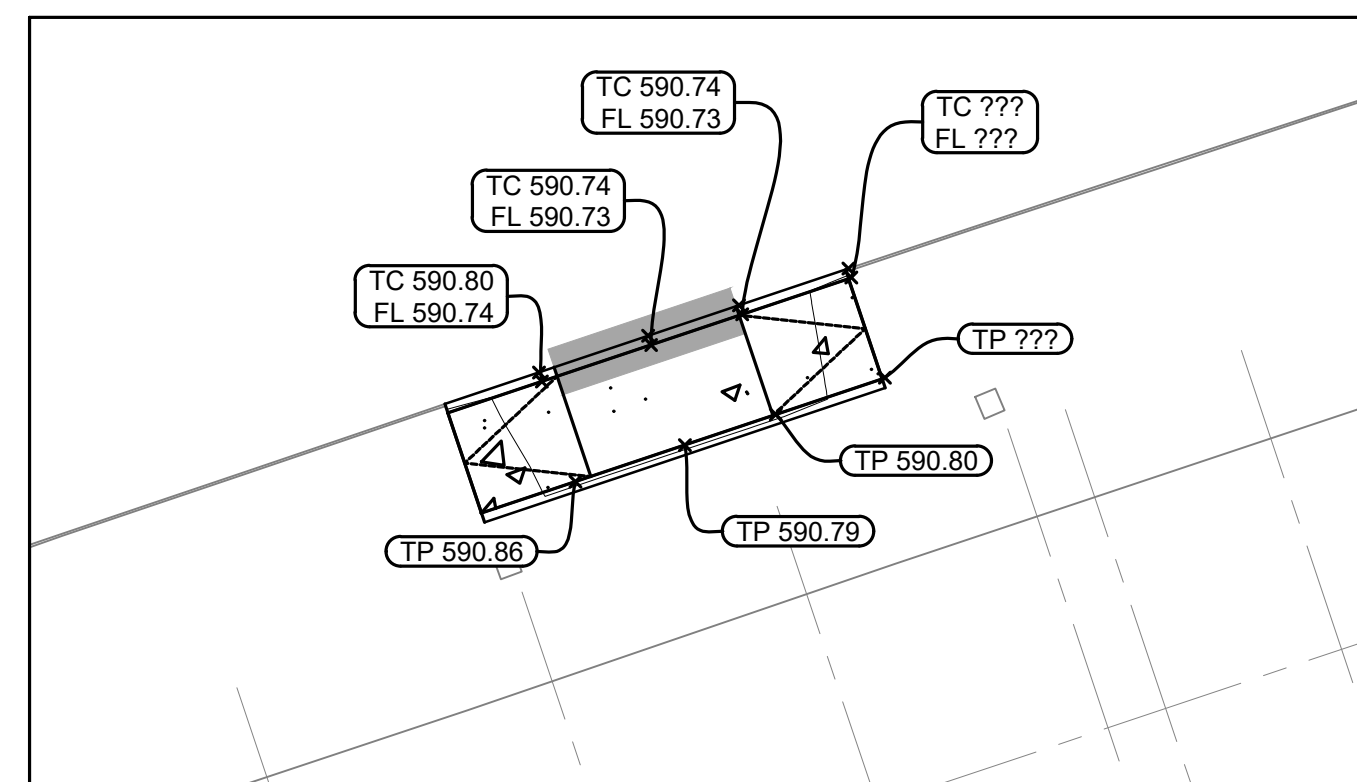

15 ADA DETAIL 15
1" = 10'

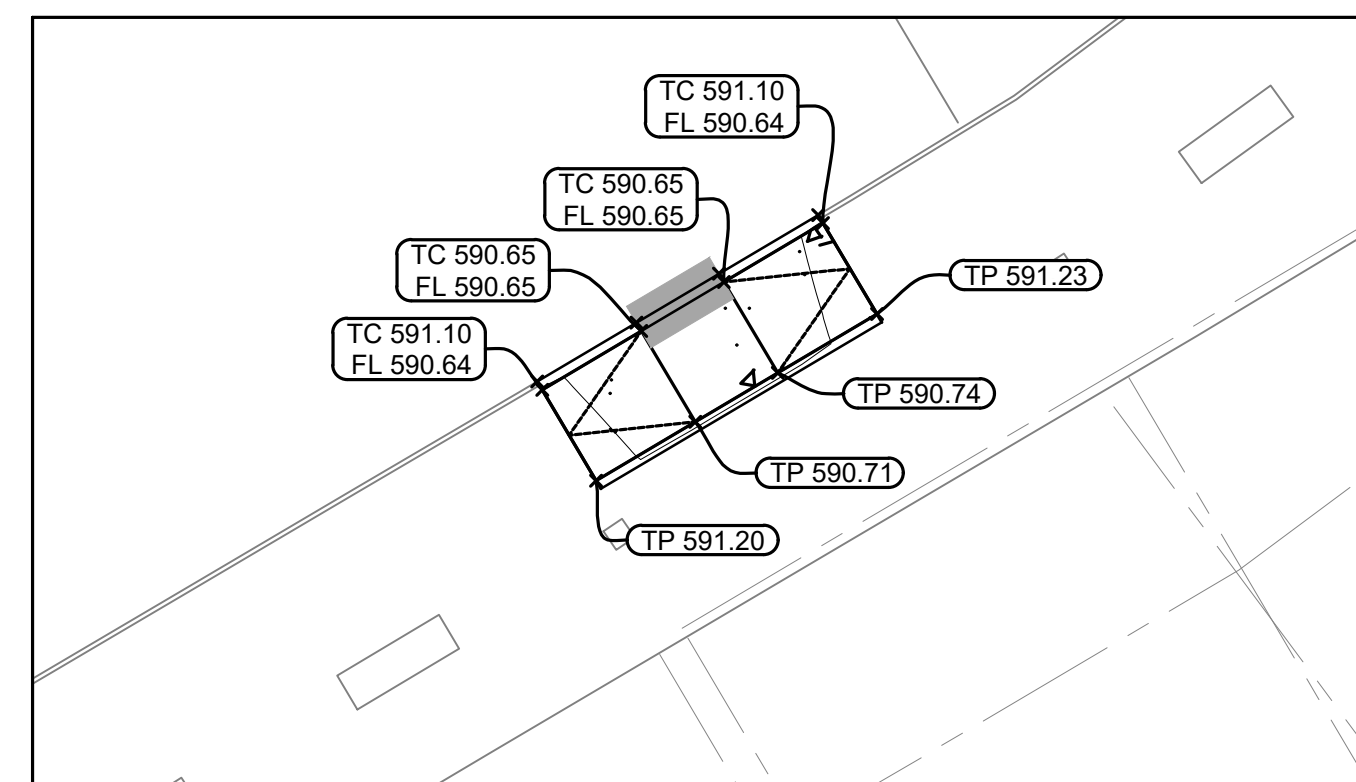

16 ADA DETAIL 16
1" = 10'

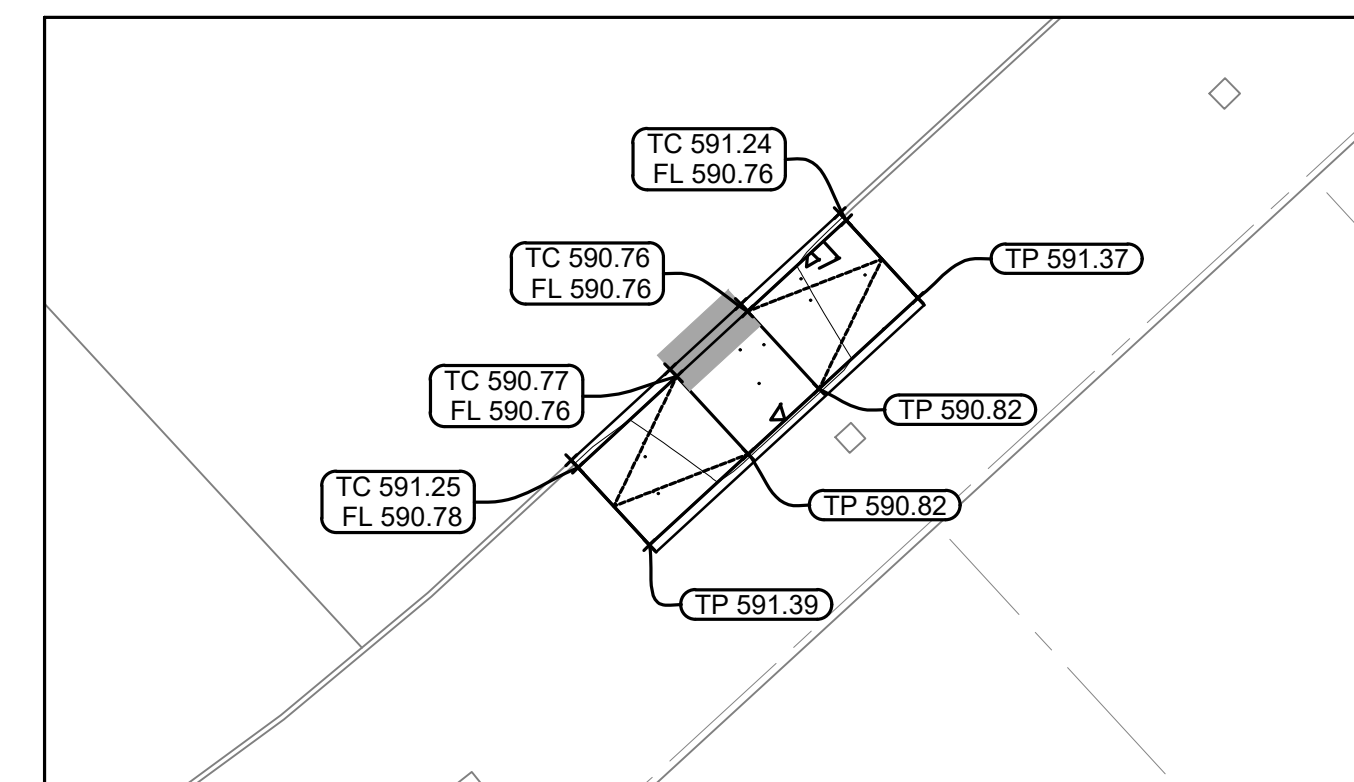

17 ADA DETAIL 17
1" = 10'

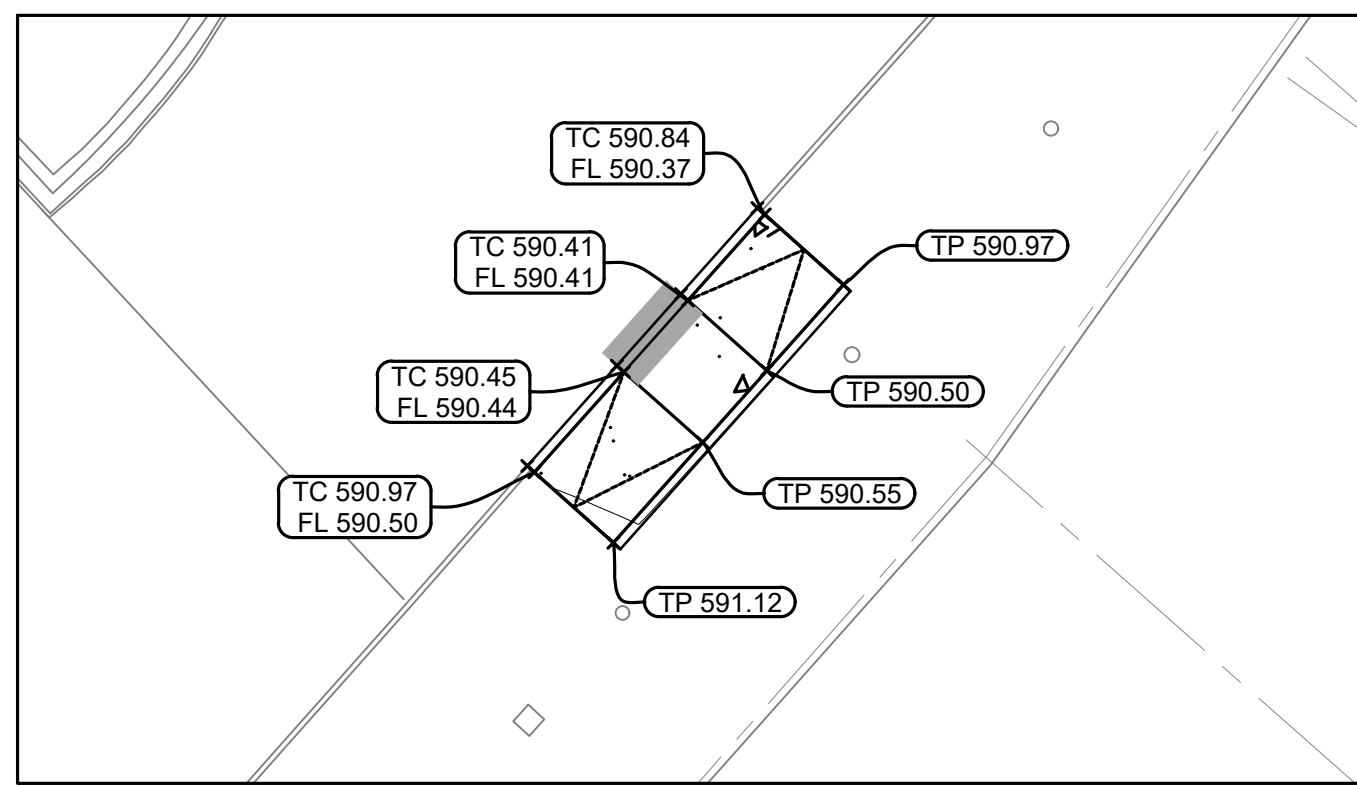

18 ADA DETAIL 18
1" = 10'

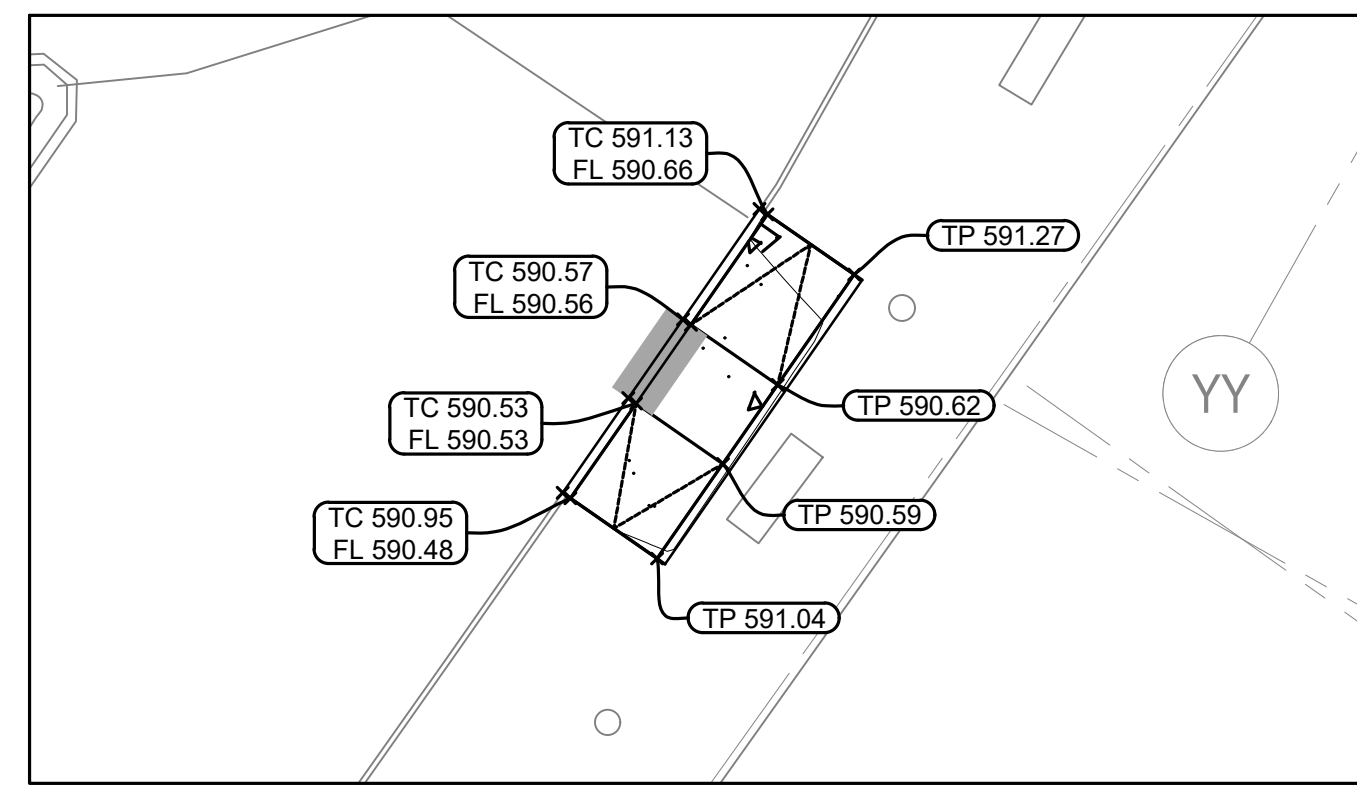

19 ADA DETAIL 19
1" = 10'

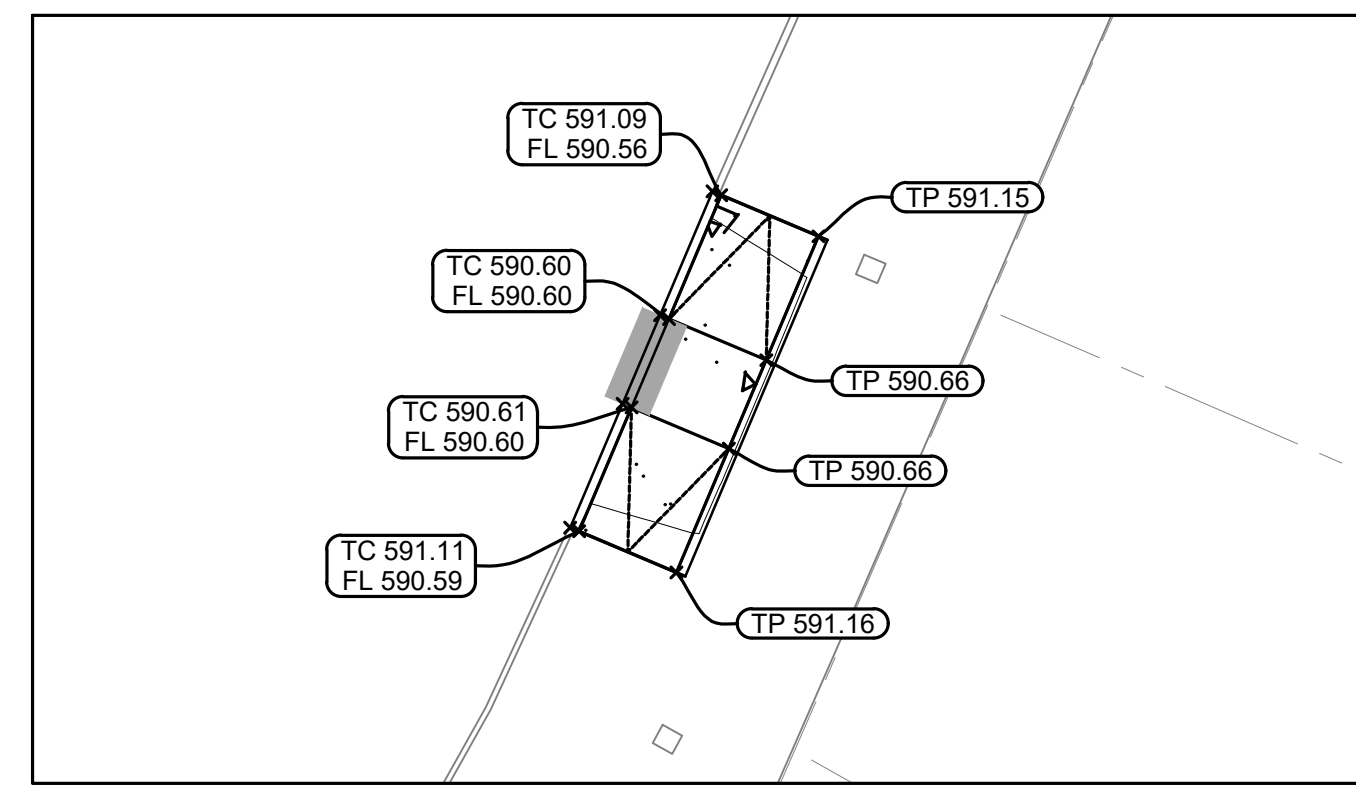

20 ADA DETAIL 20
1" = 10'

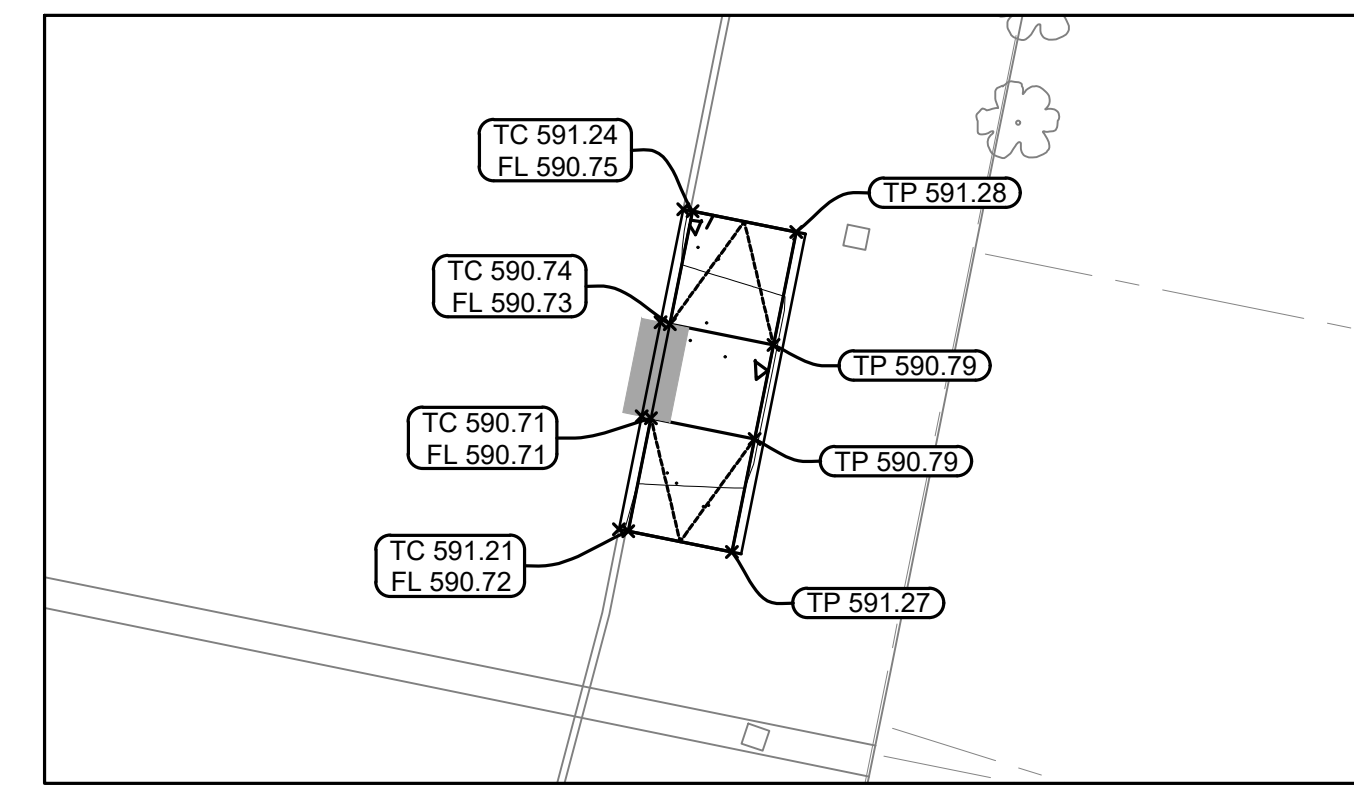

21 ADA DETAIL 21
1" = 10'

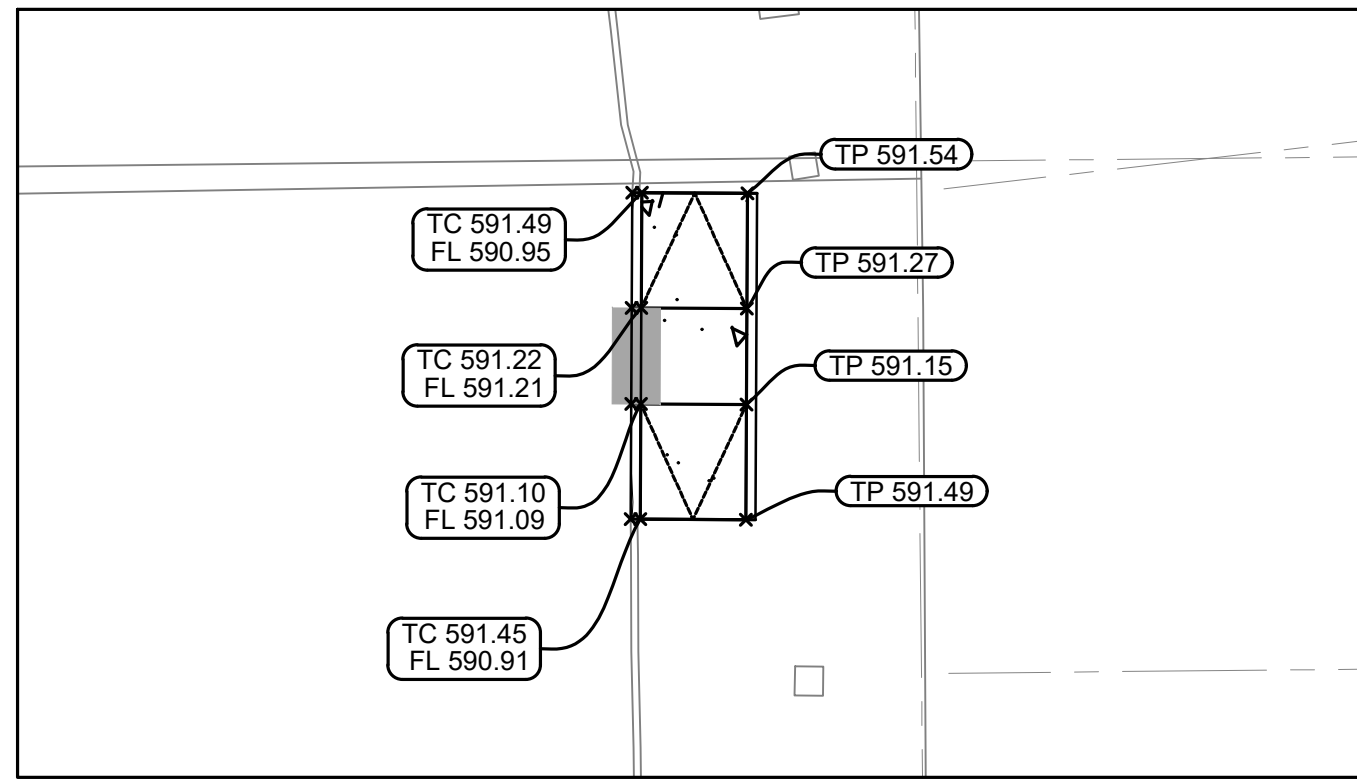

22 ADA DETAIL 22
1" = 10'

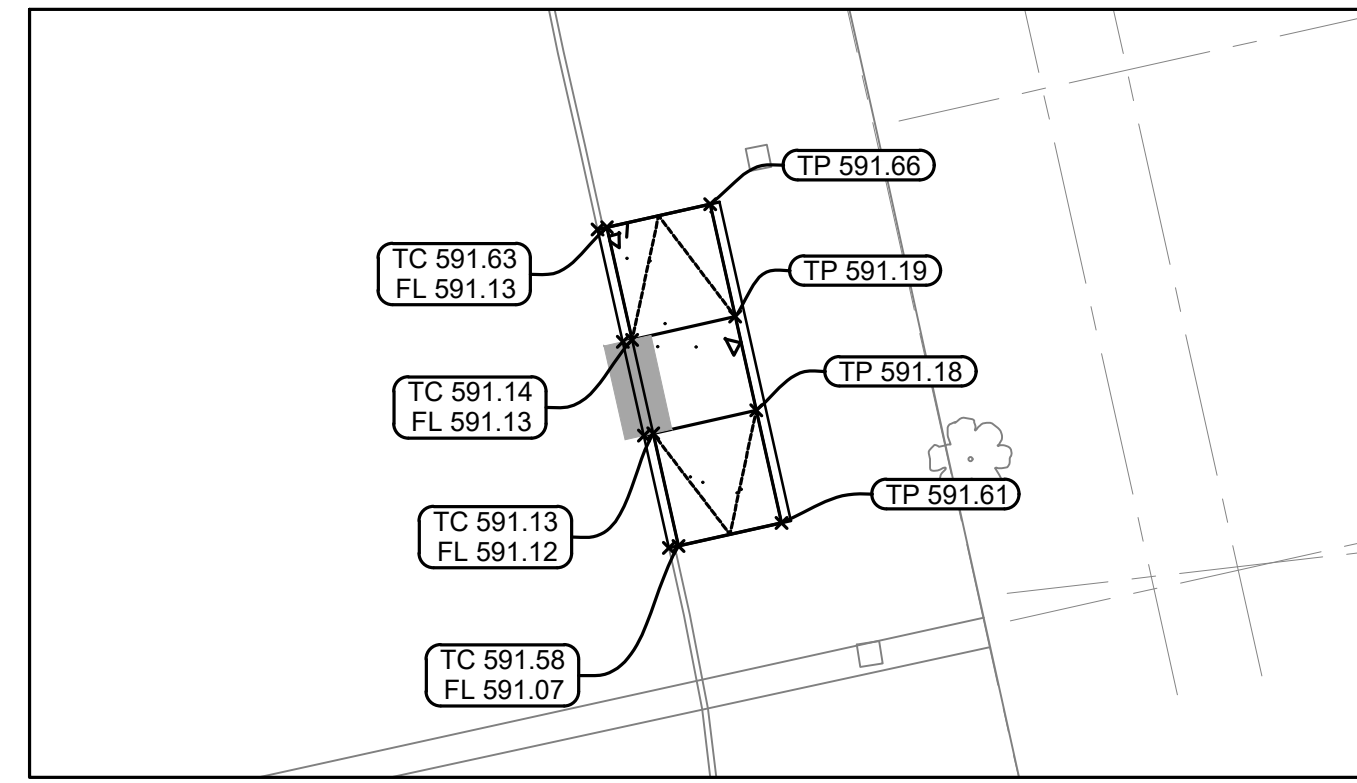

23 ADA DETAIL 23
1" = 10'

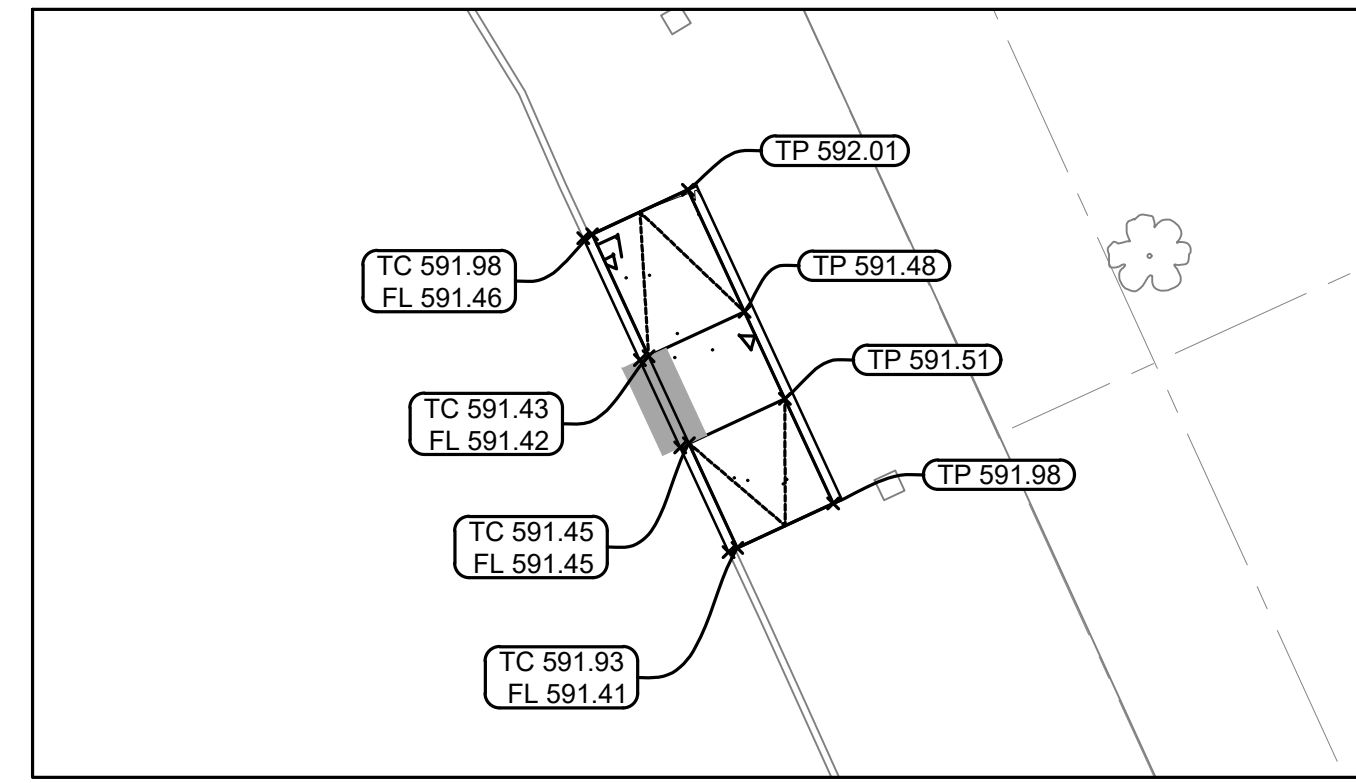

24 ADA DETAIL 24
1" = 10'

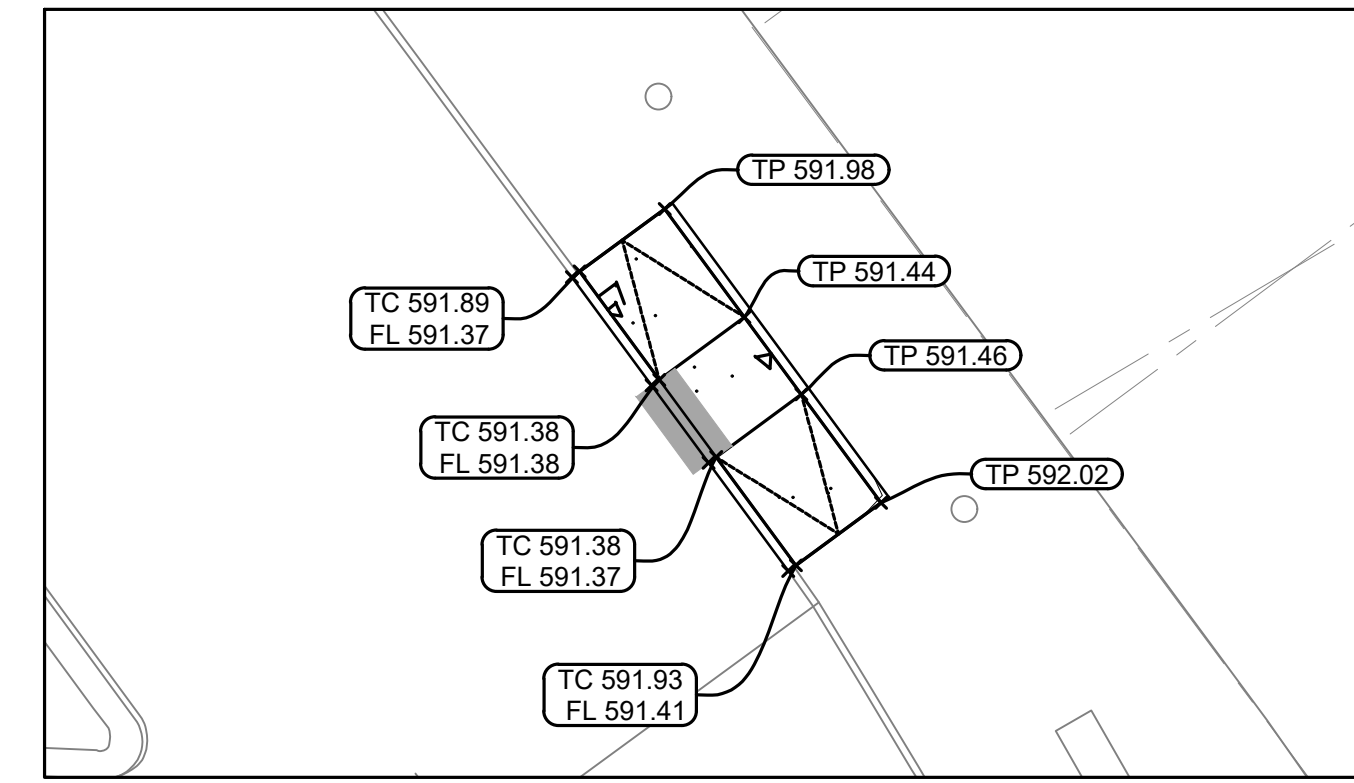

25 ADA DETAIL 25
1" = 10'

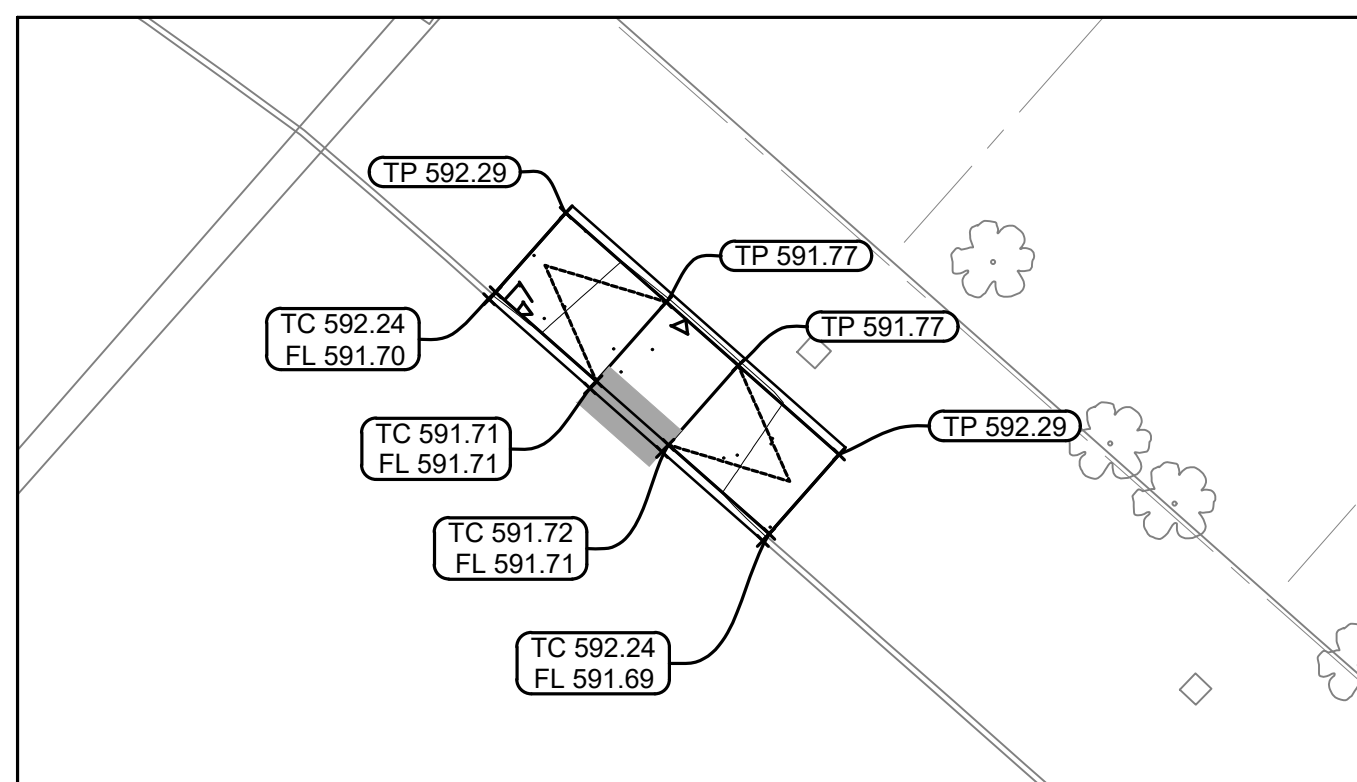

26 ADA DETAIL 26
1" = 10'

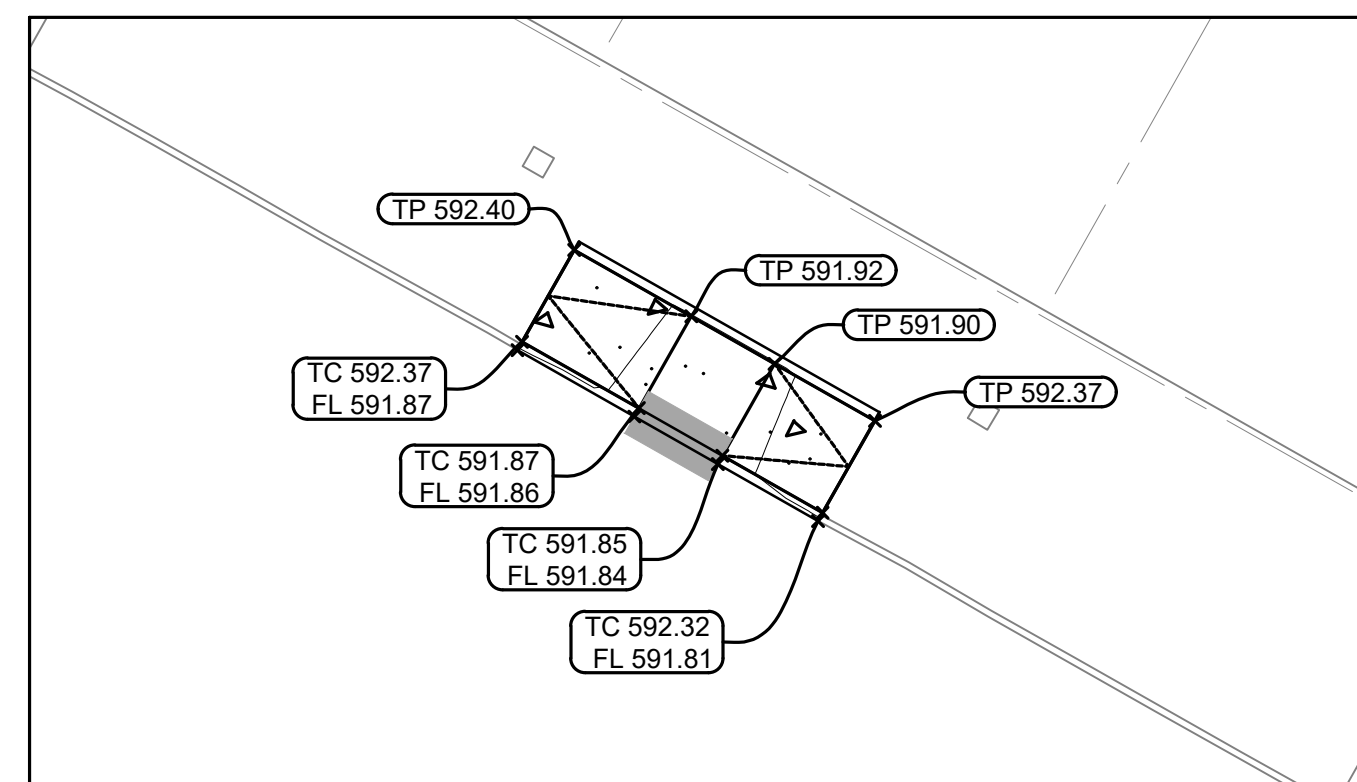

27 ADA DETAIL 27
1" = 10'

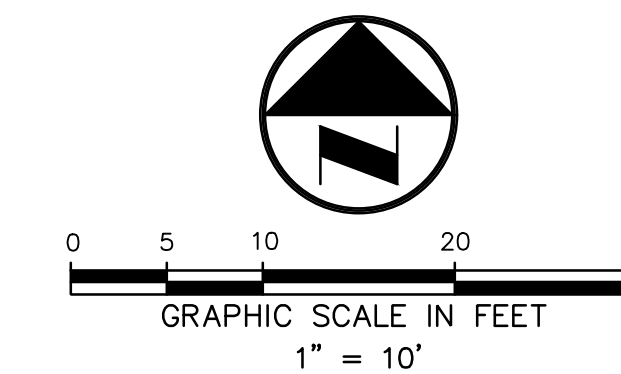

EXISTING LEGEND

- CRIADO CONTROL POINT
- IRON ROD FOUND
- BOLLARD
- GAS METER
- TRAFFIC SIGNAL LIGHT POLE
- TRAFFIC SIGNAL PULL BOX
- TRAFFIC SIGNAL CONTROL BOX
- TELECOM SERVICE BOX
- TELECOM PEDESTAL
- CATV PEDESTAL
- CATV JUNCTION BOX
- CATV APPURTENANCE
- CATHODIC PROTECTION
- FLAG POLE
- GENERIC MANHOLE
- POWER POLE
- GUYWIRE
- ELECTRIC MANHOLE
- ELECTRIC PULL BOX
- ELECTRIC METER
- ELECTRIC BOX
- ELECTRIC RISER
- GROUND LIGHT SIGN
- GAS PUMP
- FUEL TANK VENT
- TREE
- BUSH
- WASTE WATER CLEANOUT
- WASTE WATER MANHOLE
- STORM DRAIN MANHOLE
- WATER VALVE
- IRRIGATION CONTROL VALVE
- SPRINKLER HEAD
- SPIGOT
- FIRE HYDRANT
- WATER METER
- OVERHEAD UTILITY
- OVERHEAD ELECTRIC

GRADING LEGEND

- 570 --- EXISTING CONTOUR
- 570 — PROPOSED CONTOUR
- (R XXX.XX) RIM ELEVATION
- (TP XXX.XX) TOP OF PAVEMENT ELEVATION
- (TW XXX.XX) TOP OF WALL ELEVATION
- (TC XXX.XX / FL XXX.XX) TOP OF CURB ELEVATION / FLOW LINE ELEVATION
- RIDGE — RIDGE LINE
- 1.50% FLOW DIRECTION AND SLOPE

GRADING NOTES

1. CONTRACTOR TO VERIFY ALL EXISTING TOPOGRAPHY AND STRUCTURES ON THE SITE AND IMMEDIATELY NOTIFY THE ENGINEER OF ANY DISCREPANCIES PRIOR TO STARTING WORK.
2. ALL PAVEMENT SPOT GRADE ELEVATIONS AND RIM ELEVATIONS WITHIN OR ALONG CURB AND GUTTER REFER TO FLOW LINE ELEVATIONS UNLESS OTHERWISE NOTED.
3. ALL ELEVATIONS SHOWN DEPICT FINISHED GRADE UNLESS OTHERWISE NOTED. GENERAL CONTRACTOR TO COORDINATE WITH EXCAVATION, LANDSCAPE AND PAVING SUBCONTRACTORS REGARDING TOPSOIL THICKNESS FOR LANDSCAPE AREAS AND PAVEMENT SECTION THICKNESS FOR PAVED AREAS TO PROPERLY ENSURE ADEQUATE CUT TO ESTABLISH SUBGRADE ELEVATIONS.
4. NO EARTHEN SLOPE SHALL BE GREATER THAN 3:1, UNLESS OTHERWISE NOTED.
5. MAXIMUM SLOPE IN ACCESSIBLE PARKING SPACES AND LOADING ZONES SHALL NOT EXCEED 2.0% IN ALL DIRECTIONS.
6. MAXIMUM RUNNING SLOPE SHALL NOT EXCEED 5% AND CROSS SLOPE SHALL NOT EXCEED 2% ON ALL SIDEWALKS AND ACCESSIBLE ROUTES.
7. WHEN NATURAL FLOW OF DRAINAGE IS AWAY FROM CURB, CONTRACTOR TO INSTALL REVERSE GUTTER PITCH.
8. MATCH EXISTING ELEVATIONS AT PROJECT LIMITS.
9. STAIRS AND ADA RAMP FOR LOADING DOCK WILL BE PREFABRICATED PAINTED STEEL ELEMENTS TO FIT

BORDER RELEASE DATE: October 16, 2021
01/20/2021 10:59:09 AM C:\Users\mcc203\OneDrive\Documents\CG503-900R\Grading\Detail\paper.dwg - Terminal C Garages and Roadways - CTA Expansion Program\Project Files\01_CTA - Terminal C Garages and Roadways\CG503-900R\Grading\Detail\paper.dwg



DALLAS
FORT WORTH
INTERNATIONAL
AIRPORT

2330 N INTERNATIONAL PARKWAY
DFW AIRPORT, TX 75261



DRAWN BY: SJP
APPROVED BY: JNA
ISSUE DATE: 2022-07-28
NOT FOR BID OR CONSTRUCTION

NO.	DATE	DESCRIPTION
1	2022-07-28	100% DESIGN
2	2022-07-28	100% DESIGN FOR PERMIT (DPP)

TERMINAL C GARAGE & ROADWAYS
GRADING DETAILS (UPPER ROADWAY)

PROJECT NUMBER: TFD-007

PERMIT NUMBER: B22-0023

SHEET NUMBER
CG503-900R

SCALE(S) AS NOTED ON THIS SHEET ARE BASED ON A FULL SIZE 30 X 42 SHEET.

BORDER RELEASE DATE: October 16, 2021
 01/22/2021 14:50:09
 C:\Users\h3c223\OneDrive\Documents\HOK\DAL\DFW\Int'l Airport - CTA Expansion Program\Project Files\01_CTA - Terminal C Garages and Roadways\DWG-TC-CT102-900-1-MOT-Lower.dwg

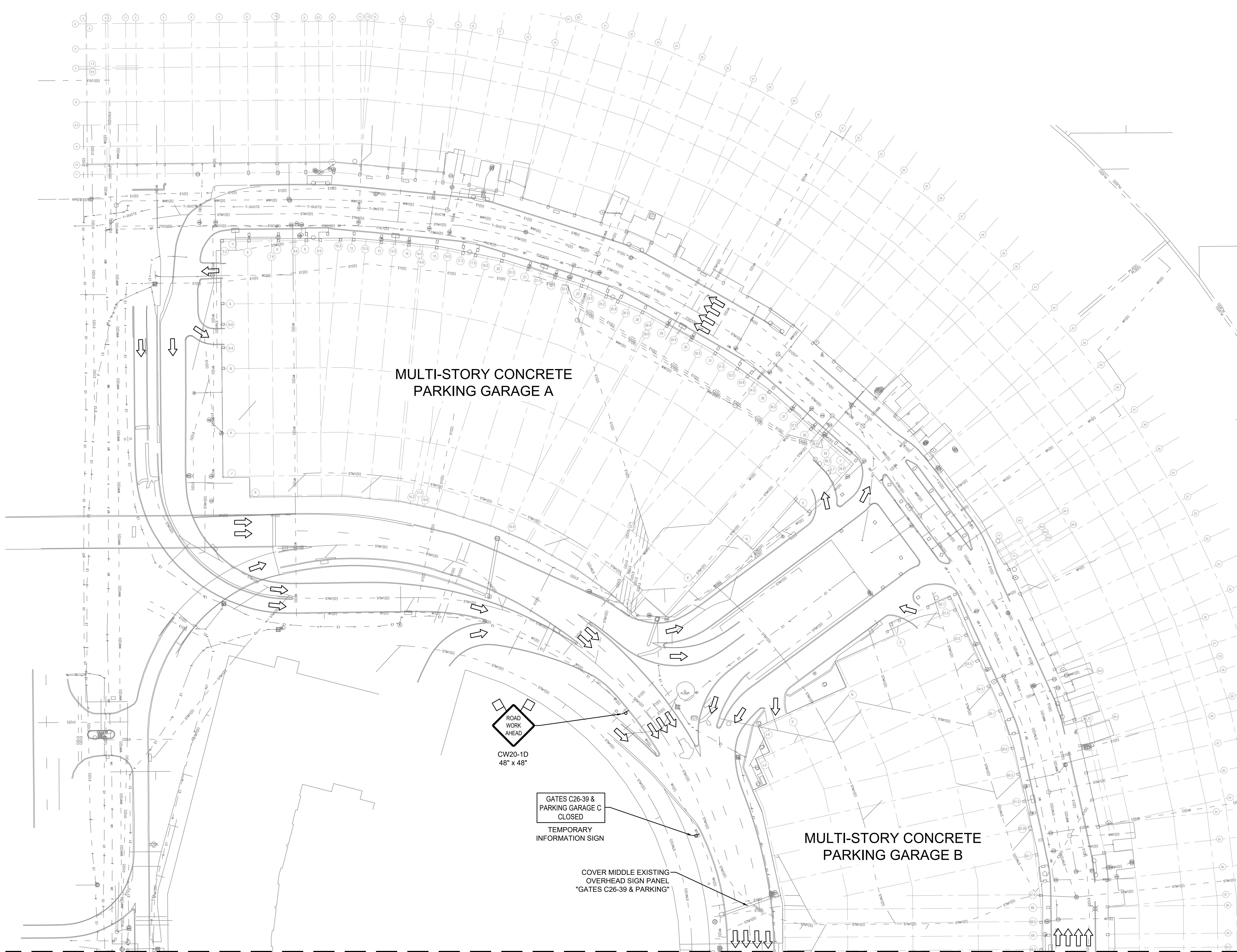

MATCHLINE - SEE SHEET CT102-900R

EXISTING LEGEND

- CRIADO CONTROL POINT
- IRON ROD FOUND
- BOLLARD
- GAS METER
- TRAFFIC SIGNAL LIGHT
- POLE
- TRAFFIC SIGNAL PULL BOX
- TRAFFIC SIGNAL CONTROL BOX
- TELECOM SERVICE BOX
- TELECOM PEDESTAL
- TELECOM MANHOLE
- CATV PEDESTAL
- CATV JUNCTION BOX
- CATV APPURTENANCE
- LIGHT POLE
- CATHODIC PROTECTION
- FLAG POLE
- GENERIC MANHOLE
- POWER POLE
- GUYWIRE
- ELECTRIC MANHOLE
- ELECTRIC PULL BOX
- ELECTRIC METER
- ELECTRIC BOX
- ELECTRIC RISER
- GROUND LIGHT
- SIGN
- GAS PUMP
- FUEL TANK VENT
- TREE
- BUSH
- WASTE WATER CLEANOUT
- WASTE WATER MANHOLE
- STORM DRAIN MANHOLE
- WATER VALVE
- IRRIGATION CONTROL VALVE
- SPRINKLER HEAD
- SPIGOT
- FIRE HYDRANT
- WATER METER
- OVERHEAD UTILITY
- OVERHEAD ELECTRIC

PROPOSED LEGEND

- WORK ZONE
- TRAFFIC FLOW ARROW
- CHANNELIZING DEVICE (FOLLOW TXDOT STANDARDS FOR DETAILS AND SPACING)
- TRAILER MOUNTED FLASHING ARROW BOARD
- TEMPORARY MOT SIGN
- TYPE III BARRICADE

- NOTES:**
1. A TRAFFIC CONTROL PLAN IS REQUIRED FOR ALL PHASING OF THE TERMINAL C ROADWAYS, AND GARAGE RECONSTRUCTION. THE TCP MUST BE SUBMITTED 2 WEEKS PRIOR TO CONSTRUCTION TO AARON ESPINOSA WITH DFW REPRESENTATIVES APPROVAL. ALL TCP PLANS SHALL FOLLOW LATEST EDITION OF "TEXAS MANUAL ON UNIFORM TRAFFIC CONTROL DEVICES" (TMUTCD) ONCE THE TCP IS APPROVED WITH THE CONTRACTORS BARRICADE PLAN, THE PROJECT MANAGER, OR CONSTRUCTION MANAGER, AND CONTRACTOR MUST ATTEND THE WEEKLY MONDAY MORNING MEETINGS AT 10:00AM TO KEEP STAFF UPDATED ON THE CLOSURE STATUS. A DIRECT CONTACT DURING THE WORK ZONE CLOSURE MUST RESPOND ASAP IN CASE ANY SIGNS, CONES, OR PROBLEM THAT MAY OCCUR DURING THE CLOSURE.
 2. SEE LOWER ROADWAY PHASING SEQUENCING NOTES ON SHEET CT100-900R FOR ADDITIONAL DETAILS.

KEY PLAN

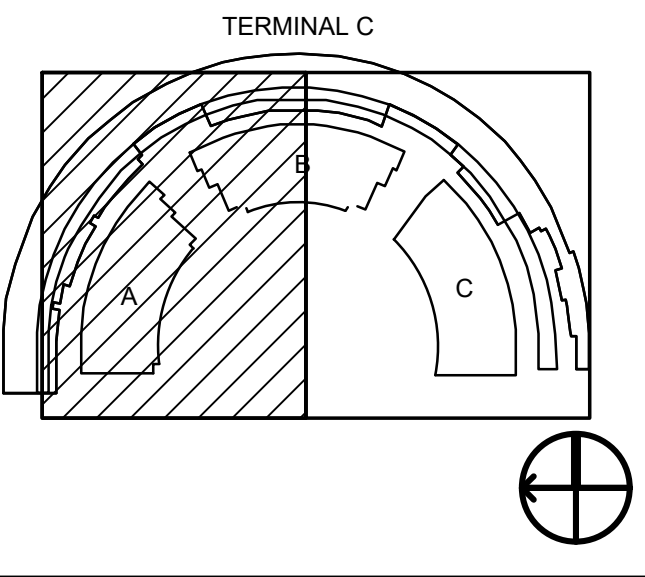

DFW DALLAS FORT WORTH INTERNATIONAL AIRPORT
 2330 N INTERNATIONAL PARKWAY
 DFW AIRPORT, TX 75261

ROBERT J. DEMING
 134776
 PROFESSIONAL ENGINEER

h+k Primera
 Heery, Chou & Keesom, Inc.
 717 South Meadows Drive
 Suite 200, LB #
 Dallas, TX 75201
 (+1) 214 720 8000

DRAWN BY: JMR
 APPROVED BY: RJD
 ISSUE DATE: 2022-07-28
NOT FOR BID OR CONSTRUCTION

NO.	DATE	DESCRIPTION
2022-01-06	30% DESIGN	
2022-05-01	100% DESIGN	
2022-07-28	100% DESIGN FOR PERMIT (D/P)	

TERMINAL C GARAGE & ROADWAYS
PHASE 1A MOT (LOWER ROADWAY)
 PROJECT NUMBER: TFD-007
 PERMIT NUMBER: B22-0023

SHEET NUMBER
CT102-900R

SCALE(S) AS NOTED ON THIS SHEET ARE BASED ON A FULL SIZE 30 X 42 SHEET.

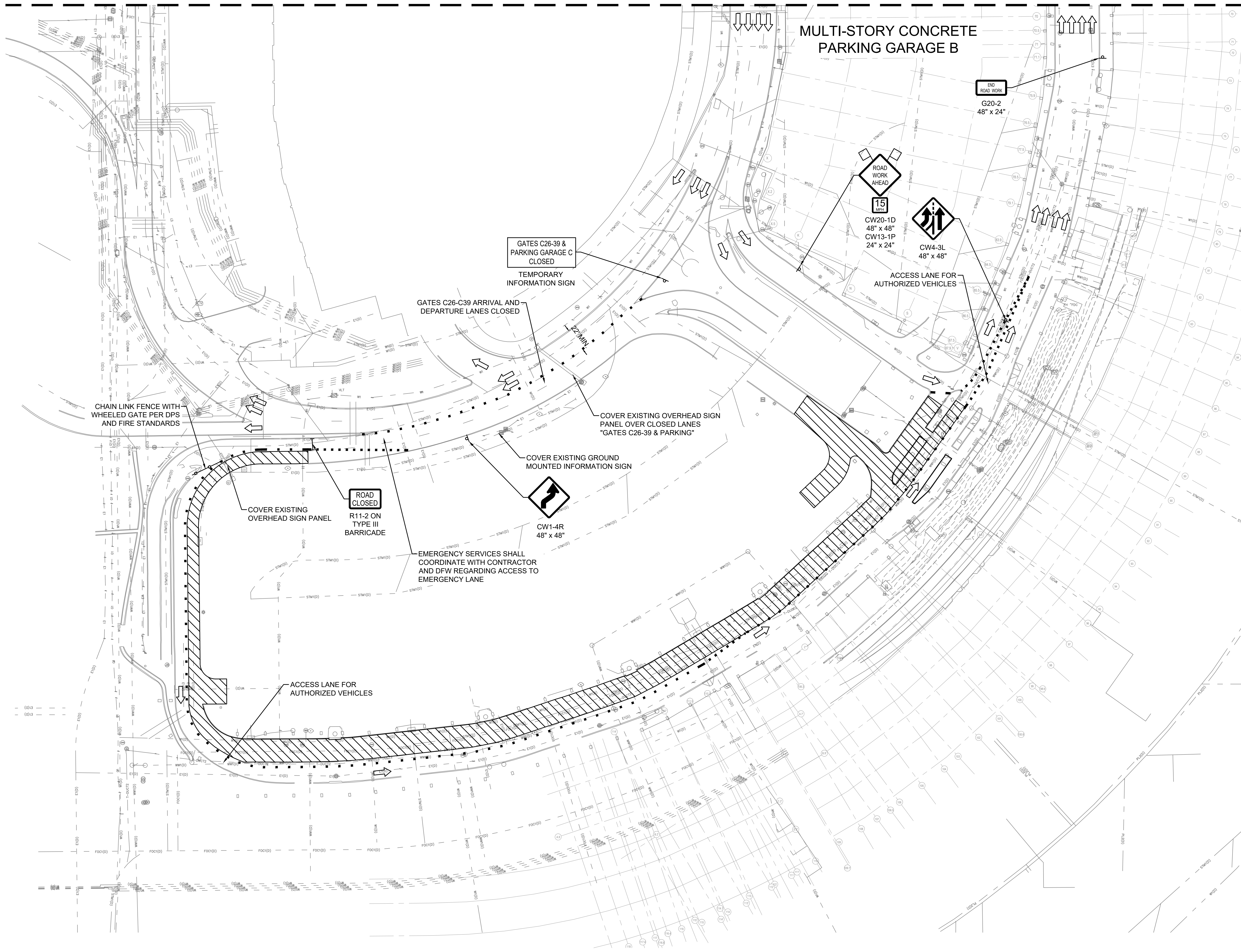

EXISTING LEGEND

- CRIADO CONTROL POINT
- IRON ROD FOUND
- BOLLARD
- GAS METER
- TRAFFIC SIGNAL LIGHT POLE
- TRAFFIC SIGNAL PULL BOX
- TRAFFIC SIGNAL CONTROL BOX
- TELECOM SERVICE BOX
- TELECOM PEDESTAL
- TELECOM MANHOLE
- CATV PEDESTAL
- CATV JUNCTION BOX
- CATV APPURTENANCE
- LIGHT POLE
- CATHODIC PROTECTION
- FLAG POLE
- GENERIC MANHOLE
- POWER POLE
- GUYWIRE
- ELECTRIC MANHOLE
- ELECTRIC PULL BOX
- ELECTRIC METER
- ELECTRIC BOX
- ELECTRIC RISER
- GROUND LIGHT
- SIGN
- GAS PUMP
- FUEL TANK VENT
- TREE
- BUSH
- WASTE WATER CLEANOUT
- WASTE WATER MANHOLE
- STORM DRAIN MANHOLE
- WATER VALVE
- IRRIGATION CONTROL VALVE
- SPRINKLER HEAD
- SPIGOT
- FIRE HYDRANT
- WATER METER
- OVERHEAD UTILITY
- OVERHEAD ELECTRIC

PROPOSED LEGEND

- WORK ZONE
- TRAFFIC FLOW ARROW
- CHANNELIZING DEVICE (FOLLOW TXDOT STANDARDS FOR DETAILS AND SPACING)
- TRAILER MOUNTED FLASHING ARROW BOARD
- TEMPORARY MOT SIGN
- TYPE III BARRICADE

NOTES:

1. A TRAFFIC CONTROL PLAN IS REQUIRED FOR ALL PHASING OF THE TERMINAL C ROADWAYS, AND GARAGE RECONSTRUCTION. THE TCP MUST BE SUBMITTED 2 WEEKS PRIOR TO CONSTRUCTION TO AARON ESPINOSA WITH DFW REPRESENTATIVES APPROVAL. ALL TCP PLANS SHALL FOLLOW LATEST EDITION OF "TEXAS MANUAL ON UNIFORM TRAFFIC CONTROL DEVICES" (TMUTCD) ONCE THE TCP IS APPROVED WITH THE CONTRACTORS BARRICADE PLAN, THE PROJECT MANAGER, OR CONSTRUCTION MANAGER, AND CONTRACTOR MUST ATTEND THE WEEKLY MONDAY MORNING MEETINGS AT 10:00AM TO KEEP STAFF UPDATED ON THE CLOSURE STATUS. A DIRECT CONTACT DURING THE WORK ZONE CLOSURE MUST RESPOND ASAP IN CASE ANY SIGNS, CONES, OR PROBLEM THAT MAY OCCUR DURING THE CLOSURE.
2. SEE LOWER ROADWAY PHASING SEQUENCING NOTES ON SHEET CT100-900R FOR ADDITIONAL DETAILS.

KEY PLAN

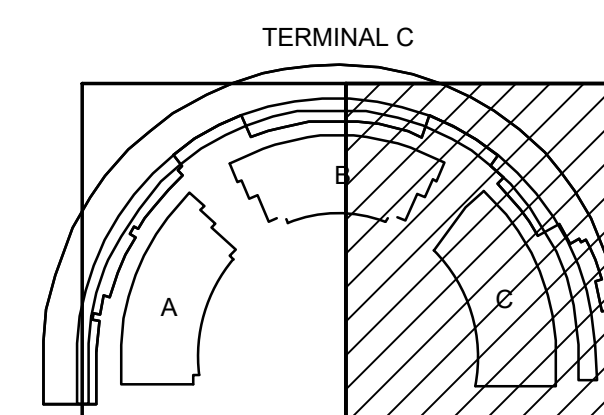

BORDER RELEASE DATE: October 16, 2021
01/20/2021 10:09:09 AM
C:\Users\hrc\OneDrive\Documents\HOK\DAL\DFW\Int'l Airport - CTA Expansion Program\Project Files\01_CTA - Terminal C Garages and Roadways\CE\01 - CAD\Sheets\010000\DFW-TC-CT101-900R.dwg



2330 N INTERNATIONAL PARKWAY
DFW AIRPORT, TX 75261

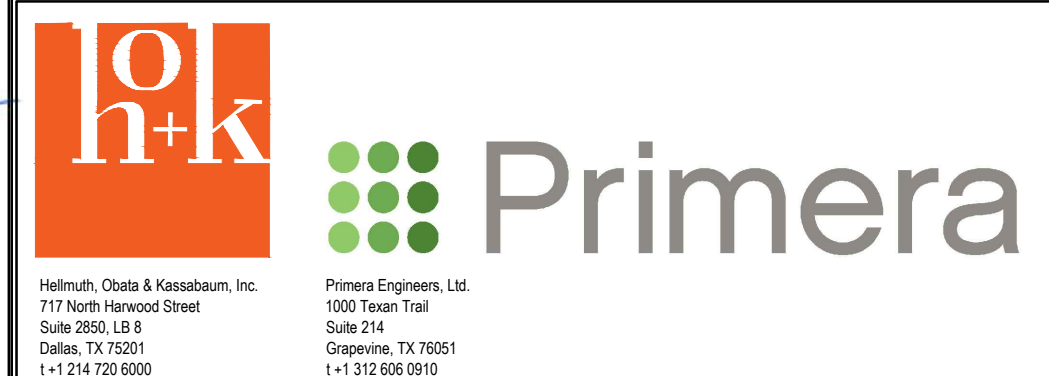
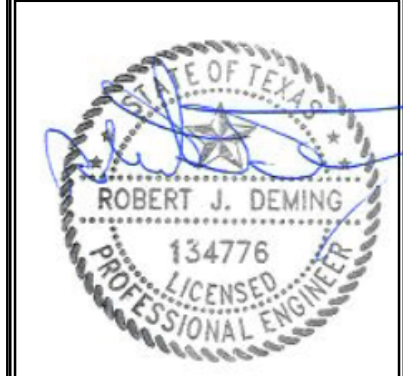

DRAWN BY: JMR
APPROVED BY: RJD
ISSUE DATE: 2022-07-28
NOT FOR BID OR CONSTRUCTION

NO.	DATE	DESCRIPTION
001	2022-01-06	30% DESIGN
002	2022-05-01	100% DESIGN
003	2022-07-28	100% DESIGN FOR PERMIT (D/P)

TERMINAL C GARAGE & ROADWAYS
PHASE 1A MOT (LOWER ROADWAY)
PROJECT NUMBER: TFD-007
PERMIT NUMBER: B22-0023

SHEET NUMBER
CT103-900R

BORDER RELEASE DATE: October 16, 2021
 01/22/2021 14:50:09
 C:\Users\h3c223\OneDrive\Documents\HOK\DAL\DFW\Int'l Airport - CTA Expansion Program\Project Files\01_CTA - Terminal C Garages and Roadways\DWG-TC-CT106-900R.dwg

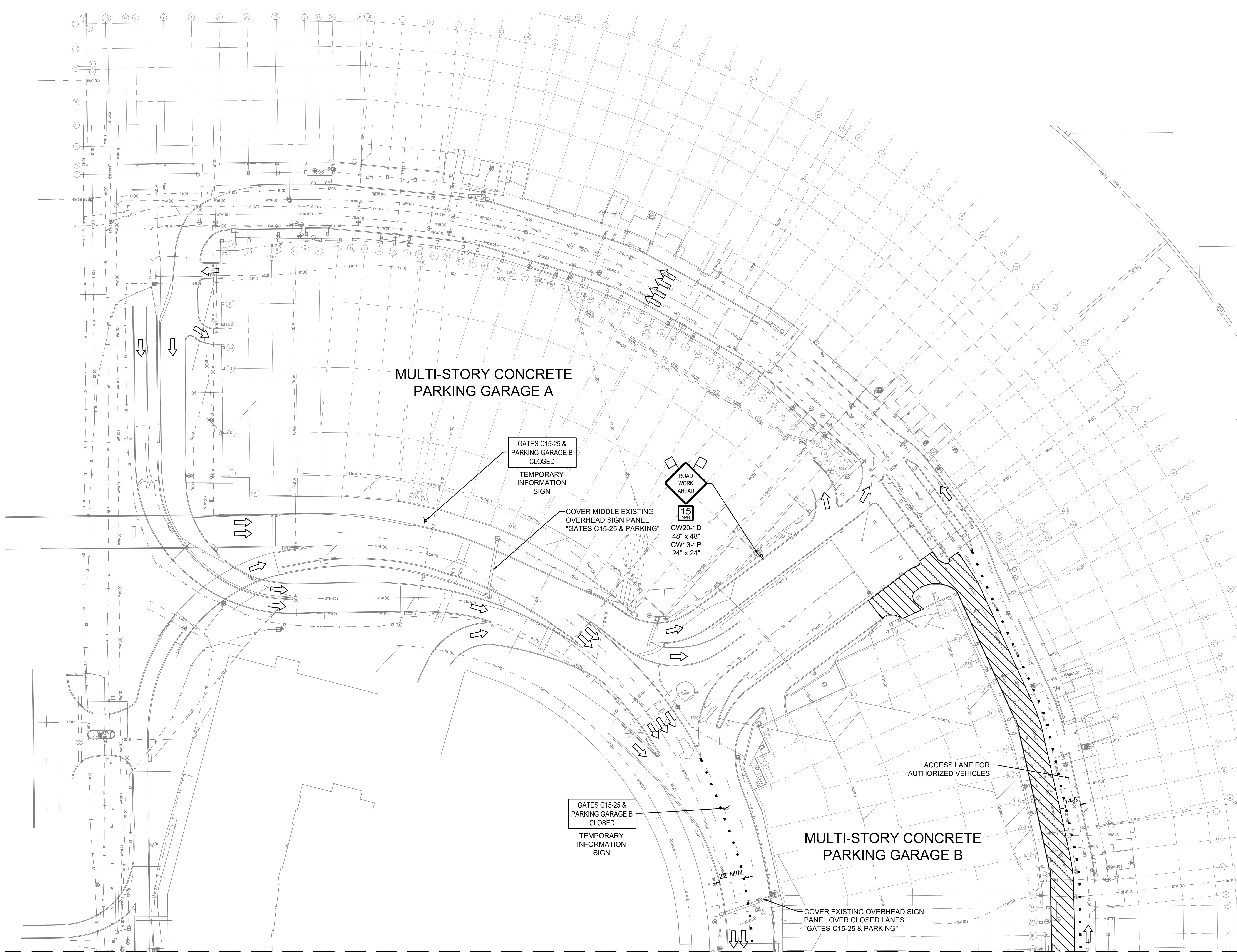

MATCHLINE - SEE SHEET CT108-900R

EXISTING LEGEND

• CRIADO CONTROL POINT	⊠ ELECTRIC PULL BOX
• IRON ROD FOUND	⊠ ELECTRIC METER
• BOLLARD	⊠ ELECTRIC BOX
• GAS METER	⊠ ELECTRIC RISER
⊠ TRAFFIC SIGNAL LIGHT	⊠ GROUND LIGHT
⊠ POLE	⊠ SIGN
• TRAFFIC SIGNAL PULL BOX	⊠ GAS PUMP
• TRAFFIC SIGNAL CONTROL BOX	⊠ FUEL TANK VENT
• TELECOM SERVICE BOX	⊠ TREE
• TELECOM PEDESTAL	⊠ BUSH
• TELECOM MANHOLE	⊠ WASTE WATER CLEANOUT
• CATV PEDESTAL	⊠ WASTE WATER MANHOLE
• CATV JUNCTION BOX	⊠ STORM DRAIN MANHOLE
• CATV APPURTENANCE	⊠ WATER VALVE
• LIGHT POLE	⊠ IRRIGATION CONTROL VALVE
• CATHODIC PROTECTION	⊠ SPRINKLER HEAD
• FLAG POLE	⊠ SPIGOT
• GENERIC MANHOLE	⊠ FIRE HYDRANT
• POWER POLE	⊠ WATER METER
• GUYWIRE	⊠ OVERHEAD UTILITY
• ELECTRIC MANHOLE	⊠ OVERHEAD ELECTRIC

PROPOSED LEGEND

	WORK ZONE
	TRAFFIC FLOW ARROW
	CHANNELIZING DEVICE (FOLLOW TXDOT STANDARDS FOR DETAILS AND SPACING)
	TRAILER MOUNTED FLASHING ARROW BOARD
	TEMPORARY MOT SIGN
	TYPE III BARRICADE

- NOTES:
1. A TRAFFIC CONTROL PLAN IS REQUIRED FOR ALL PHASING OF THE TERMINAL C ROADWAYS, AND GARAGE RECONSTRUCTION. THE TCP MUST BE SUBMITTED 2 WEEKS PRIOR TO CONSTRUCTION TO AARON ESPINOSA WITH DFW REPRESENTATIVES APPROVAL. ALL TCP PLANS SHALL FOLLOW LATEST EDITION OF "TEXAS MANUAL ON UNIFORM TRAFFIC CONTROL DEVICES" (TMUTCD) ONCE THE TCP IS APPROVED WITH THE CONTRACTORS BARRICADE PLAN, THE PROJECT MANAGER, OR CONSTRUCTION MANAGER, AND CONTRACTOR MUST ATTEND THE WEEKLY MONDAY MORNING MEETINGS AT 10:00AM TO KEEP STAFF UPDATED ON THE CLOSURE STATUS. A DIRECT CONTACT DURING THE WORK ZONE CLOSURE MUST RESPOND ASAP IN CASE ANY SIGNS, CONES, OR PROBLEM THAT MAY OCCUR DURING THE CLOSURE.
 2. SEE LOWER ROADWAY PHASING SEQUENCING NOTES ON SHEET CT100-900R FOR ADDITIONAL DETAILS.

KEY PLAN

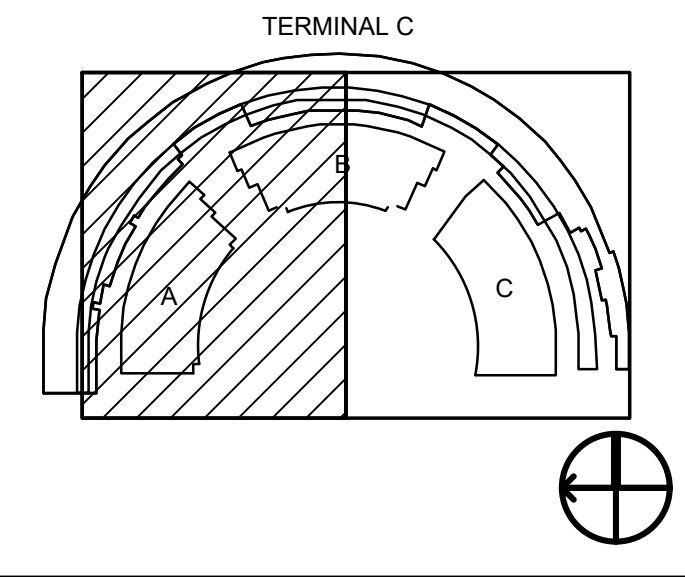

DALLAS
 FORT WORTH
 INTERNATIONAL
 AIRPORT
 2330 N INTERNATIONAL PARKWAY
 DFW AIRPORT, TX 75261

ROBERT J. DEMING
 134776
 PROFESSIONAL ENGINEER

Primera
 Project Engineers, LLC
 300 West 7th
 Suite 211
 Dallas, TX 75201
 (+1) 214 720 8000

DRAWN BY: JMR
 APPROVED BY: RJD
 ISSUE DATE: 2022-07-28
NOT FOR BID OR CONSTRUCTION

NO.	DATE	DESCRIPTION
2022-01-06		30% DESIGN
2022-03-01		100% DESIGN
2022-07-28		100% DESIGN FOR PERMIT (DFP)

TERMINAL C GARAGE & ROADWAYS
PHASE 2A MOT (LOWER ROADWAY)
 PROJECT NUMBER: TFD-007
 PERMIT NUMBER: B22-0023

SHEET NUMBER
CT106-900R

SCALE(S) AS NOTED ON THIS SHEET ARE BASED ON A FULL SIZE 30 X 42 SHEET.

MATCHLINE - SEE SHEET CT107-900R

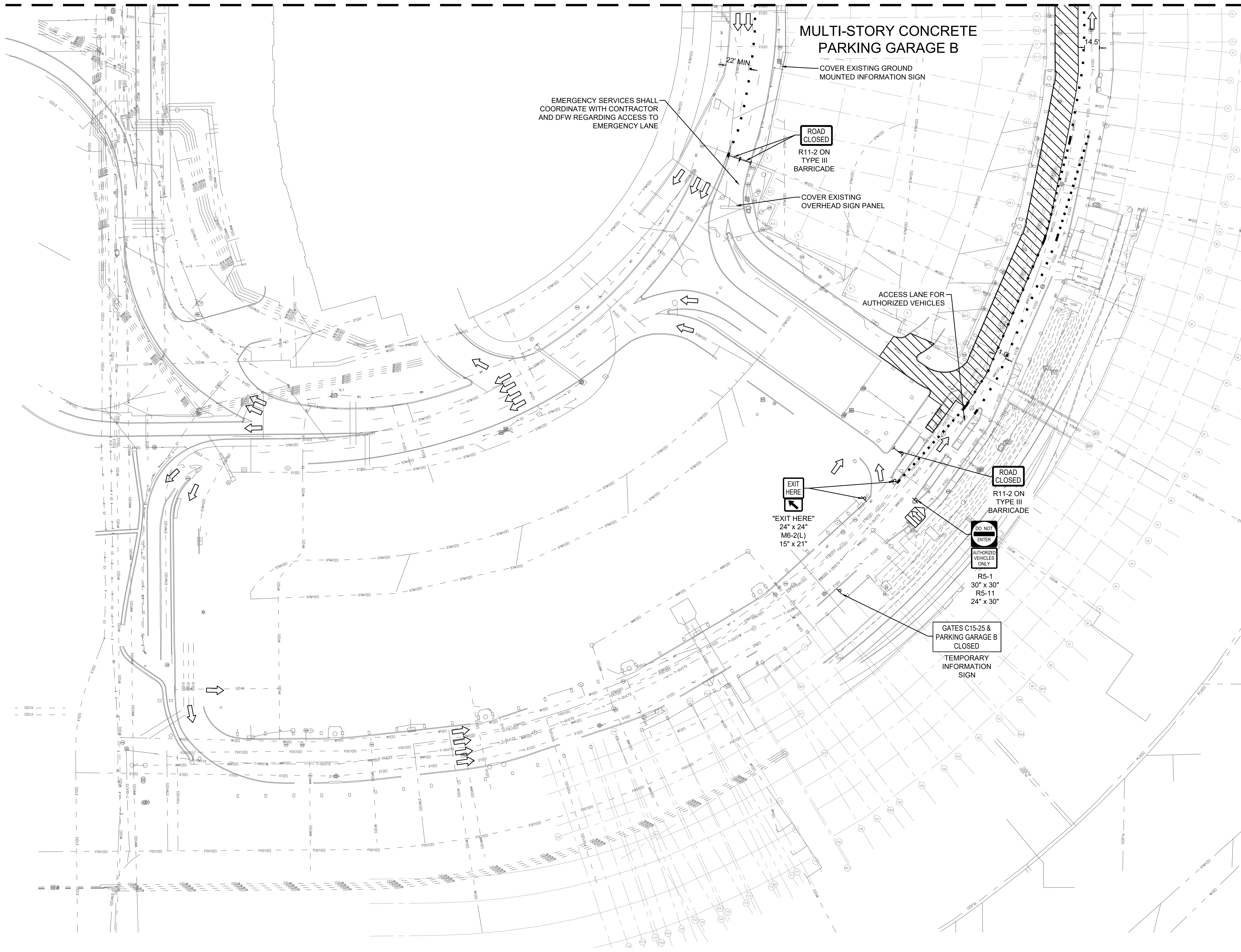

EXISTING LEGEND

- CRIADO CONTROL POINT
- IRON ROD FOUND
- BOLLARD
- GAS METER
- TRAFFIC SIGNAL LIGHT POLE
- TRAFFIC SIGNAL PULL BOX
- TRAFFIC SIGNAL CONTROL BOX
- TELECOM SERVICE BOX
- TELECOM PEDESTAL
- TELECOM MANHOLE
- CATV PEDESTAL
- CATV JUNCTION BOX
- CATV APPURTENANCE
- LIGHT POLE
- CATHODIC PROTECTION
- FLAG POLE
- GENERIC MANHOLE
- POWER POLE
- GUYWIRE
- ELECTRIC MANHOLE
- ELECTRIC PULL BOX
- ELECTRIC METER
- ELECTRIC BOX
- ELECTRIC RISER
- GROUND LIGHT SIGN
- GAS PUMP
- FUEL TANK VENT
- TREE
- BUSH
- WASTE WATER CLEANOUT
- WASTE WATER MANHOLE
- STORM DRAIN MANHOLE
- WATER VALVE
- IRRIGATION CONTROL VALVE
- SPRINKLER HEAD
- SPIGOT
- FIRE HYDRANT
- WATER METER
- OVERHEAD UTILITY
- OVERHEAD ELECTRIC

PROPOSED LEGEND

- WORK ZONE
- TRAFFIC FLOW ARROW
- CHANNELIZING DEVICE (FOLLOW TXDOT STANDARDS FOR DETAILS AND SPACING)
- TRAILER MOUNTED FLASHING ARROW BOARD
- TEMPORARY MOT SIGN
- TYPE III BARRICADE

NOTES:

1. A TRAFFIC CONTROL PLAN IS REQUIRED FOR ALL PHASING OF THE TERMINAL C ROADWAYS, AND GARAGE RECONSTRUCTION. THE TCP MUST BE SUBMITTED 2 WEEKS PRIOR TO CONSTRUCTION TO AARON ESPINOSA WITH DFW REPRESENTATIVES APPROVAL. ALL TCP PLANS SHALL FOLLOW LATEST EDITION OF "TEXAS MANUAL ON UNIFORM TRAFFIC CONTROL DEVICES" (TMUTCD) ONCE THE TCP IS APPROVED WITH THE CONTRACTORS BARRICADE PLAN, THE PROJECT MANAGER, OR CONSTRUCTION MANAGER, AND CONTRACTOR MUST ATTEND THE WEEKLY MONDAY MORNING MEETINGS AT 10:00AM TO KEEP STAFF UPDATED ON THE CLOSURE STATUS. A DIRECT CONTACT DURING THE WORK ZONE CLOSURE MUST RESPOND ASAP IN CASE ANY SIGNS, CONES, OR PROBLEM THAT MAY OCCUR DURING THE CLOSURE.
2. SEE LOWER ROADWAY PHASING SEQUENCING NOTES ON SHEET CT100-900R FOR ADDITIONAL DETAILS.

KEY PLAN

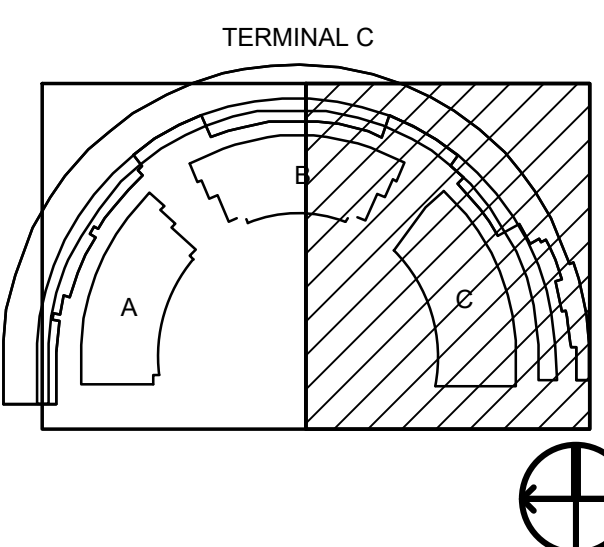

BORDER RELEASE DATE: October 16, 2021
01/20/2021 10:50:09 AM
C:\Users\hrc22\OneDrive\Documents\HOK\DAL\DFW\Info\Airport - CTA Expansion\Program\Project Files\01_CTA - Terminal C Garages and Roadways\02_DFW-TC-CT1-0-0101-MOT\Lower.dwg



DALLAS FORT WORTH INTERNATIONAL AIRPORT
2330 N INTERNATIONAL PARKWAY
DFW AIRPORT, TX 75261

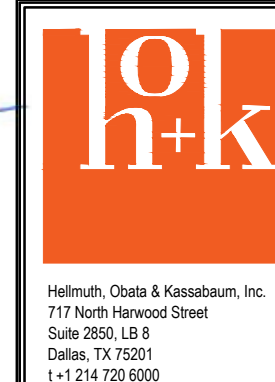
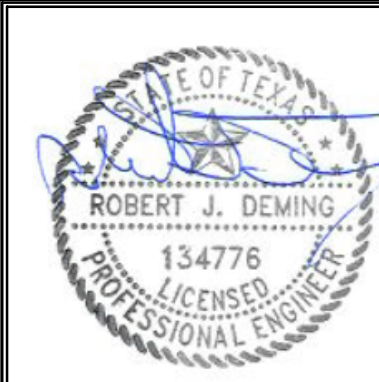

DRAWN BY: JMR
APPROVED BY: RJD
ISSUE DATE: 2022-07-28
NOT FOR BID OR CONSTRUCTION

NO.	DATE	DESCRIPTION
1	2022-01-06	30% DESIGN
2	2022-03-01	100% DESIGN
3	2022-07-28	100% REVISED FOR PERMIT (RFP)

PROJECT NUMBER: TFD-007

TERMINAL C GARAGE & ROADWAYS
PHASE 2A MOT (LOWER ROADWAY)

PERMIT NUMBER: B22-0023

SHEET NUMBER
CT107-900R

SCALE(S) AS NOTED ON THIS SHEET ARE BASED ON A FULL SIZE 30 X 42 SHEET.

BORDER RELEASE DATE: October 16, 2021
 01/2/2021 14:50:09
 C:\Users\h3c223\OneDrive\Documents\HOK\DAL\DFW\Int'l Airport - CTA Expansion Program\Project Files\01_CTA - Terminal C Garages and Roadways\DWG\CT110-900R.dwg

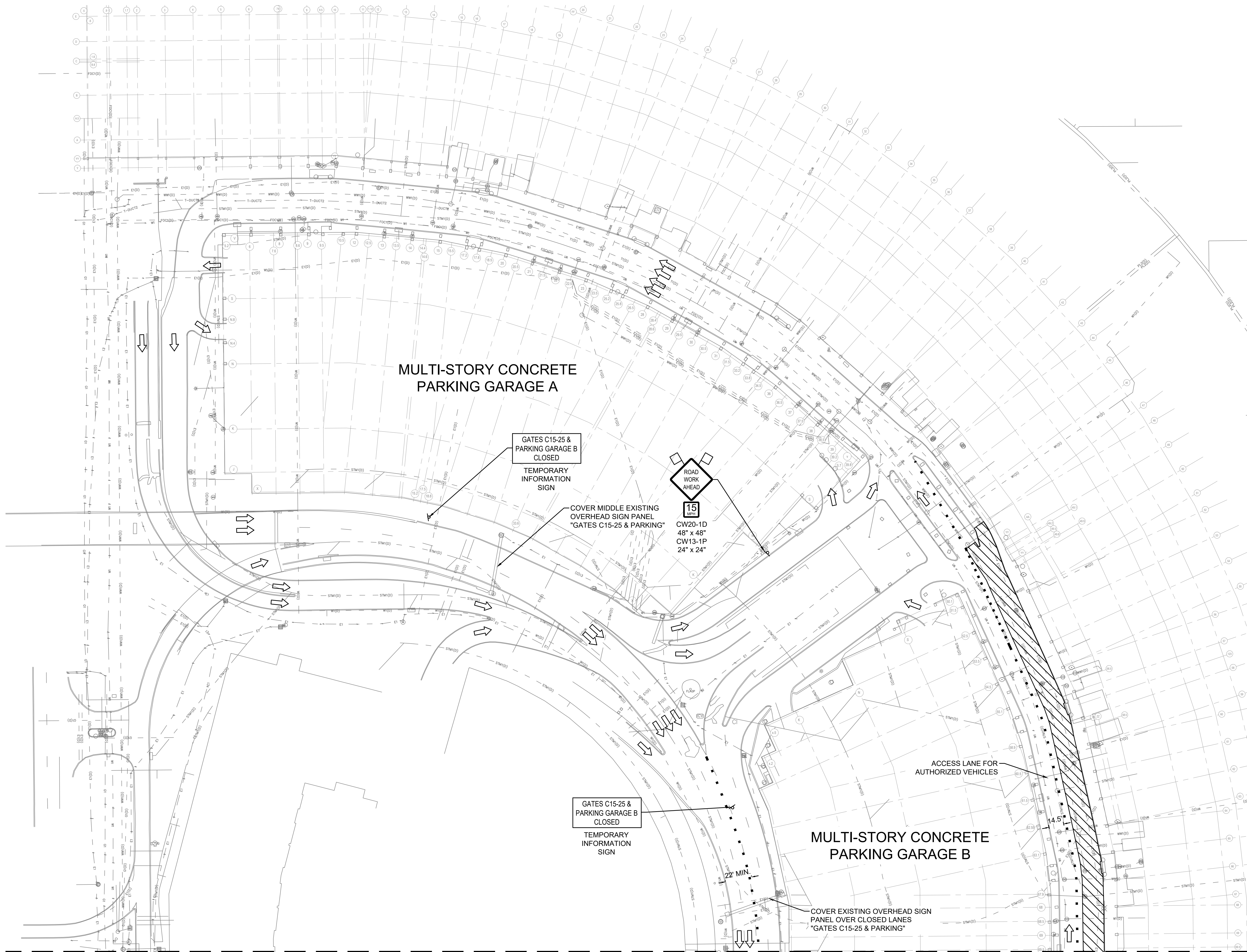

EXISTING LEGEND

• CRIADO CONTROL POINT	⊠ ELECTRIC PULL BOX
• IRON ROD FOUND	⊠ ELECTRIC METER
• BOLLARD	⊠ ELECTRIC BOX
• GAS METER	⊠ ELECTRIC RISER
⊠ TRAFFIC SIGNAL LIGHT	⊠ GROUND LIGHT
⊠ POLE	⊠ SIGN
• TRAFFIC SIGNAL PULL BOX	⊠ GAS PUMP
⊠ TRAFFIC SIGNAL CONTROL BOX	⊠ FUEL TANK VENT
⊠ TELECOM SERVICE BOX	⊠ TREE
⊠ TELECOM PEDESTAL	⊠ BUSH
⊠ TELECOM MANHOLE	⊠ WASTE WATER CLEANOUT
⊠ CATV PEDESTAL	⊠ WASTE WATER MANHOLE
⊠ CATV JUNCTION BOX	⊠ STORM DRAIN MANHOLE
⊠ CATV APPURTENANCE	⊠ WATER VALVE
⊠ LIGHT POLE	⊠ IRRIGATION CONTROL VALVE
⊠ CATHODIC PROTECTION	⊠ SPRINKLER HEAD
⊠ FLAG POLE	⊠ SPIGOT
⊠ GENERIC MANHOLE	⊠ FIRE HYDRANT
⊠ POWER POLE	⊠ WATER METER
⊠ GUYWIRE	⊠ OVERHEAD UTILITY
⊠ ELECTRIC MANHOLE	⊠ OVERHEAD ELECTRIC

PROPOSED LEGEND

	WORK ZONE
	TRAFFIC FLOW ARROW
	CHANNELIZING DEVICE (FOLLOW TXDOT STANDARDS FOR DETAILS AND SPACING)
	TRAILER MOUNTED FLASHING ARROW BOARD
	TEMPORARY MOT SIGN
	TYPE III BARRICADE

- NOTES:
1. A TRAFFIC CONTROL PLAN IS REQUIRED FOR ALL PHASING OF THE TERMINAL C ROADWAYS, AND GARAGE RECONSTRUCTION. THE TCP MUST BE SUBMITTED 2 WEEKS PRIOR TO CONSTRUCTION TO AARON ESPINOSA WITH DFW REPRESENTATIVES APPROVAL. ALL TCP PLANS SHALL FOLLOW LATEST EDITION OF "TEXAS MANUAL ON UNIFORM TRAFFIC CONTROL DEVICES" (TMUTCD) ONCE THE TCP IS APPROVED WITH THE CONTRACTORS BARRICADE PLAN, THE PROJECT MANAGER, OR CONSTRUCTION MANAGER, AND CONTRACTOR MUST ATTEND THE WEEKLY MONDAY MORNING MEETINGS AT 10:00AM TO KEEP STAFF UPDATED ON THE CLOSURE STATUS. A DIRECT CONTACT DURING THE WORK ZONE CLOSURE MUST RESPOND ASAP IN CASE ANY SIGNS, CONES, OR PROBLEM THAT MAY OCCUR DURING THE CLOSURE.
 2. SEE LOWER ROADWAY PHASING SEQUENCING NOTES ON SHEET CT100-900R FOR ADDITIONAL DETAILS.

MATCHLINE - SEE SHEET CT110-900R

KEY PLAN

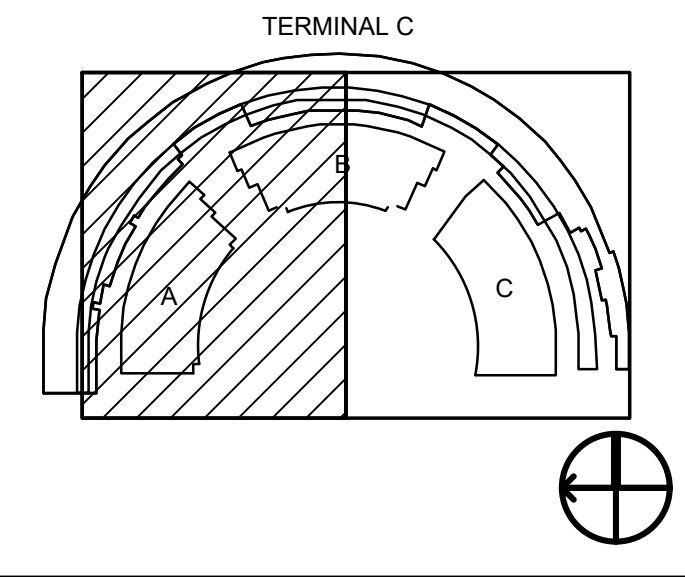

DALLAS
 FORT WORTH
 INTERNATIONAL
 AIRPORT
 2330 N INTERNATIONAL PARKWAY
 DFW AIRPORT, TX 75261

ROBERT J. DEMING
 134776
 PROFESSIONAL ENGINEER

Primera
 Professional Engineers, Ltd.
 300 West 7th
 Suite 211
 Dallas, TX 75201
 (+1) 214 720 8000

DRAWN BY: JMR
 APPROVED BY: RJD
 ISSUE DATE: 2022-07-28
NOT FOR BID OR CONSTRUCTION

NO.	DATE	DESCRIPTION
2022-01-06		30% DESIGN
2022-03-01		100% DESIGN
2022-07-28		100% DESIGN FOR PERMIT (D/P)

TERMINAL C GARAGE & ROADWAYS
PHASE 2B MOT (LOWER ROADWAY)
 PROJECT NUMBER: TFD-007
 PERMIT NUMBER: B22-0023

SHEET NUMBER
CT108-900R

SCALE(S) AS NOTED ON THIS SHEET ARE BASED ON A FULL SIZE 30 X 42 SHEET.

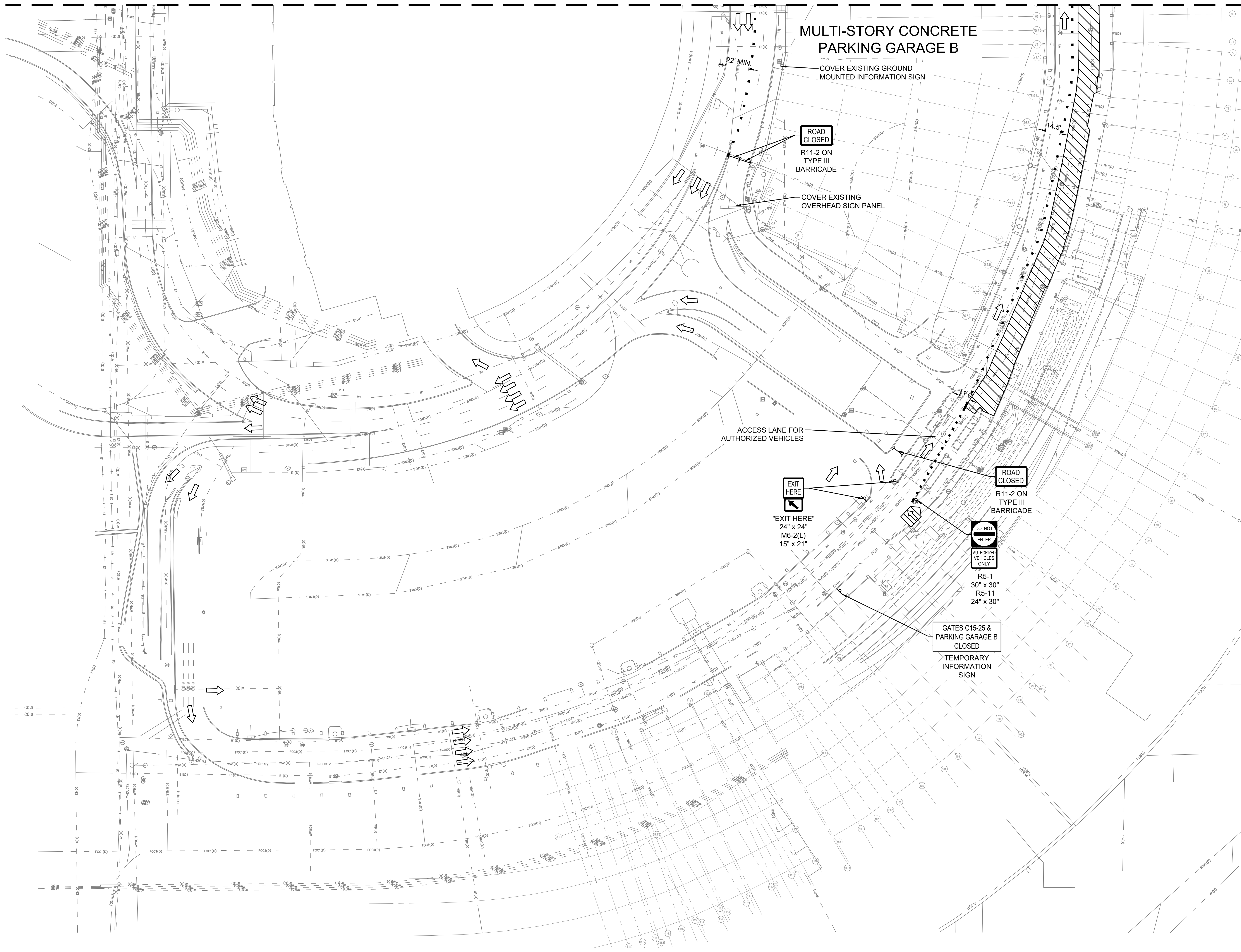

EXISTING LEGEND

- CRIADO CONTROL POINT
- IRON ROD FOUND
- BOLLARD
- GAS METER
- TRAFFIC SIGNAL LIGHT POLE
- TRAFFIC SIGNAL PULL BOX
- TRAFFIC SIGNAL CONTROL BOX
- TELECOM SERVICE BOX
- TELECOM PEDESTAL
- TELECOM MANHOLE
- CATV PEDESTAL
- CATV JUNCTION BOX
- CATV APPURTENANCE
- LIGHT POLE
- CATHODIC PROTECTION
- FLAG POLE
- GENERIC MANHOLE
- POWER POLE
- GUYWIRE
- ELECTRIC MANHOLE
- ELECTRIC PULL BOX
- ELECTRIC METER
- ELECTRIC BOX
- ELECTRIC RISER
- GROUND LIGHT SIGN
- GAS PUMP
- FUEL TANK VENT
- TREE
- BUSH
- WASTE WATER CLEANOUT
- WASTE WATER MANHOLE
- STORM DRAIN MANHOLE
- WATER VALVE
- IRRIGATION CONTROL VALVE
- SPRINKLER HEAD
- SPIGOT
- FIRE HYDRANT
- WATER METER
- OVERHEAD UTILITY
- OVERHEAD ELECTRIC

PROPOSED LEGEND

- WORK ZONE
- TRAFFIC FLOW ARROW
- CHANNELIZING DEVICE (FOLLOW TXDOT STANDARDS FOR DETAILS AND SPACING)
- TRAILER MOUNTED FLASHING ARROW BOARD
- TEMPORARY MOT SIGN
- TYPE III BARRICADE

NOTES:

1. A TRAFFIC CONTROL PLAN IS REQUIRED FOR ALL PHASING OF THE TERMINAL C ROADWAYS, AND GARAGE RECONSTRUCTION. THE TCP MUST BE SUBMITTED 2 WEEKS PRIOR TO CONSTRUCTION TO AARON ESPINOSA WITH DFW REPRESENTATIVES APPROVAL. ALL TCP PLANS SHALL FOLLOW LATEST EDITION OF "TEXAS MANUAL ON UNIFORM TRAFFIC CONTROL DEVICES" (TMUTCD) ONCE THE TCP IS APPROVED WITH THE CONTRACTORS BARRICADE PLAN, THE PROJECT MANAGER, OR CONSTRUCTION MANAGER, AND CONTRACTOR MUST ATTEND THE WEEKLY MONDAY MORNING MEETINGS AT 10:00AM TO KEEP STAFF UPDATED ON THE CLOSURE STATUS. A DIRECT CONTACT DURING THE WORK ZONE CLOSURE MUST RESPOND ASAP IN CASE ANY SIGNS, CONES, OR PROBLEM THAT MAY OCCUR DURING THE CLOSURE.
2. SEE LOWER ROADWAY PHASING SEQUENCING NOTES ON SHEET CT100-900R FOR ADDITIONAL DETAILS.

KEY PLAN

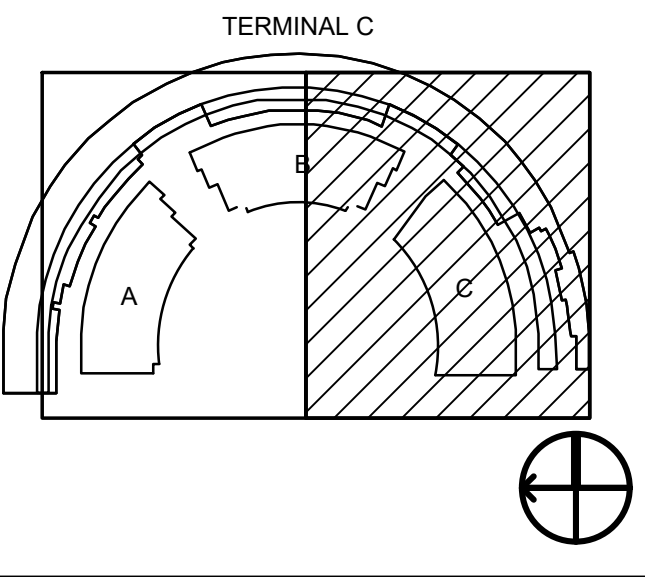

BORDER RELEASE DATE: October 16, 2021
 01/22/2021 10:09 AM
 C:\Users\hrc222\OneDrive\Documents\HOK\DAL\DFW\Info\Airport - CTA Expansion Program\Project Files\01_CTA - Terminal C Garages and Roadways\CE\01 - CAD\Sheets\8000852-DFW-TC-CT109-900R.dwg

DFW DALLAS FORT WORTH INTERNATIONAL AIRPORT
 2330 N INTERNATIONAL PARKWAY
 DFW AIRPORT, TX 75261

ROBERT J. DEMING
 134776
 PROFESSIONAL ENGINEER

h+k Primera
 Heery, Choe & Keesom, Inc.
 717 South Main Street
 Suite 200, LB #
 Dallas, TX 75201
 +1 214 720 8000

DRAWN BY: JMR
 APPROVED BY: RJD
 ISSUE DATE: 2022-07-28
NOT FOR BID OR CONSTRUCTION

NO.	DATE	DESCRIPTION
2022-01-06	30% DESIGN	
2022-03-01	100% DESIGN	
2022-07-28	100% REVISED FOR PERMIT (RFP)	

TERMINAL C GARAGE & ROADWAYS
PHASE 2B MOT (LOWER ROADWAY)
 PROJECT NUMBER: TFD-007
 PERMIT NUMBER: B22-0023

SHEET NUMBER
CT109-900R

SCALE(S) AS NOTED ON THIS SHEET ARE BASED ON A FULL SIZE 30 X 42 SHEET.

BORDER RELEASE DATE: October 16, 2021
 01/20/2021 14:50:09
 C:\Users\h3c2203\OneDrive\Documents\DWG\DAL\DFW\Int'l Airport - CTA Expansion Program\Project Files\01_CTA - Terminal C Garages and Roadways\CE\01 - CAD\Sheets\800082-DFW-TC-CT110-0101-MOT\Lower.dwg

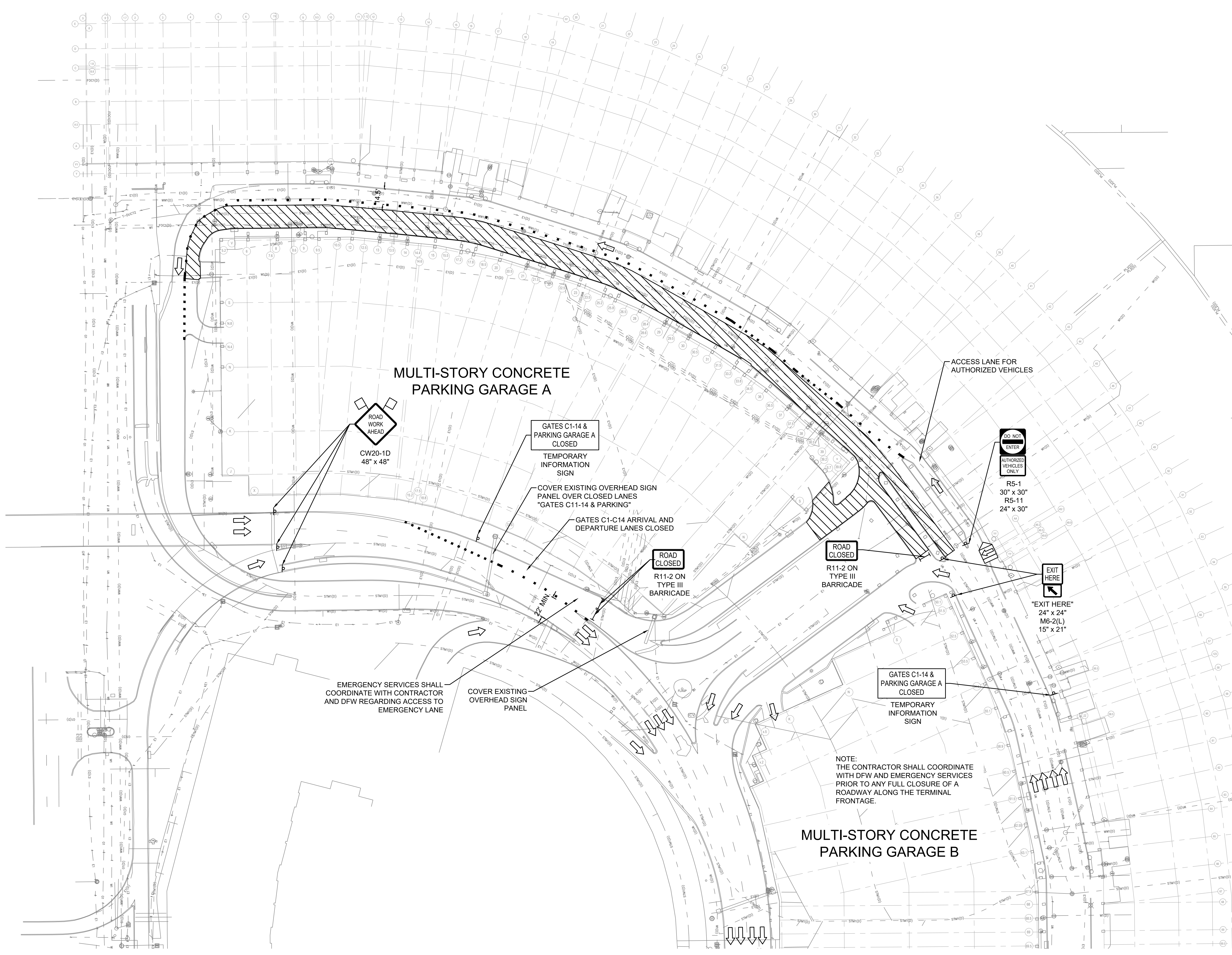

EXISTING LEGEND

- CRIADO CONTROL POINT
- IRON ROD FOUND
- BOLLARD
- GAS METER
- TRAFFIC SIGNAL LIGHT
- POLE
- TRAFFIC SIGNAL PULL BOX
- TRAFFIC SIGNAL CONTROL BOX
- TELECOM SERVICE BOX
- TELECOM PEDESTAL
- TELECOM MANHOLE
- CATV PEDESTAL
- CATV JUNCTION BOX
- CATV APPURTENANCE
- LIGHT POLE
- CATHODIC PROTECTION
- FLAG POLE
- GENERIC MANHOLE
- POWER POLE
- GUYWIRE
- ELECTRIC MANHOLE
- ELECTRIC PULL BOX
- ELECTRIC METER
- ELECTRIC BOX
- ELECTRIC RISER
- GROUND LIGHT
- SIGN
- GAS PUMP
- FUEL TANK VENT
- TREE
- BUSH
- WASTE WATER CLEANOUT
- WASTE WATER MANHOLE
- STORM DRAIN MANHOLE
- WATER VALVE
- IRRIGATION CONTROL VALVE
- SPRINKLER HEAD
- SPIGOT
- FIRE HYDRANT
- WATER METER
- OVERHEAD UTILITY
- OVERHEAD ELECTRIC

PROPOSED LEGEND

- WORK ZONE
- TRAFFIC FLOW ARROW
- CHANNELIZING DEVICE (FOLLOW TXDOT STANDARDS FOR DETAILS AND SPACING)
- TRAILER MOUNTED FLASHING ARROW BOARD
- TEMPORARY MOT SIGN
- TYPE III BARRICADE

NOTES:

1. A TRAFFIC CONTROL PLAN IS REQUIRED FOR ALL PHASING OF THE TERMINAL C ROADWAYS, AND GARAGE RECONSTRUCTION. THE TCP MUST BE SUBMITTED 2 WEEKS PRIOR TO CONSTRUCTION TO AARON ESPINOSA WITH DFW REPRESENTATIVES APPROVAL. ALL TCP PLANS SHALL FOLLOW LATEST EDITION OF "TEXAS MANUAL ON UNIFORM TRAFFIC CONTROL DEVICES" (TMUTCD) ONCE THE TCP IS APPROVED WITH THE CONTRACTORS BARRICADE PLAN, THE PROJECT MANAGER, OR CONSTRUCTION MANAGER, AND CONTRACTOR MUST ATTEND THE WEEKLY MONDAY MORNING MEETINGS AT 10:00AM TO KEEP STAFF UPDATED ON THE CLOSURE STATUS. A DIRECT CONTACT DURING THE WORK ZONE CLOSURE MUST RESPOND ASAP IN CASE ANY SIGNS, CONES, OR PROBLEM THAT MAY OCCUR DURING THE CLOSURE.
2. SEE LOWER ROADWAY PHASING SEQUENCING NOTES ON SHEET CT100-900R FOR ADDITIONAL DETAILS.

MULTI-STORY CONCRETE PARKING GARAGE B

KEY PLAN

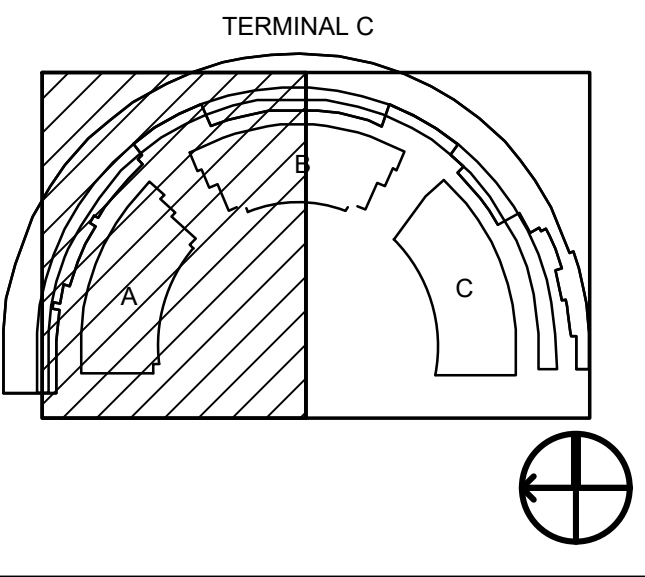

2330 N INTERNATIONAL PARKWAY
 DFW AIRPORT, TX 75261

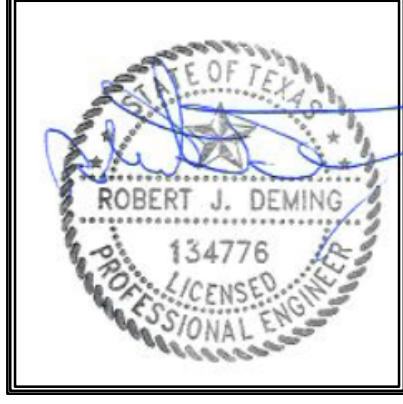

DRAWN BY: JMR
 APPROVED BY: RJD
 ISSUE DATE: 2022-07-28
NOT FOR BID OR CONSTRUCTION

NO.	DATE	DESCRIPTION
2022-01-06	30% DESIGN	
2022-03-01	100% DESIGN	
2022-07-28	100% DESIGN FOR PERMIT (DPP)	

TERMINAL C GARAGE & ROADWAYS
PHASE 3A MOT (LOWER ROADWAY)
 PROJECT NUMBER: TFD-007
 PERMIT NUMBER: B22-0023

SHEET NUMBER
CT110-900R

SCALE(S) AS NOTED ON THIS SHEET ARE BASED ON A FULL SIZE 30 X 42 SHEET.

BORDER RELEASE DATE: October 16, 2021
 01/22/2021 10:59:09 AM
 C:\Users\h3c222\OneDrive\Documents\CTA - Terminal C Expansions\Program\Project Files\01_CTA - Terminal C Garages and Roadways\DWG\DFW-Terminal C-CTA-14-0101-MOT-Lower.dwg

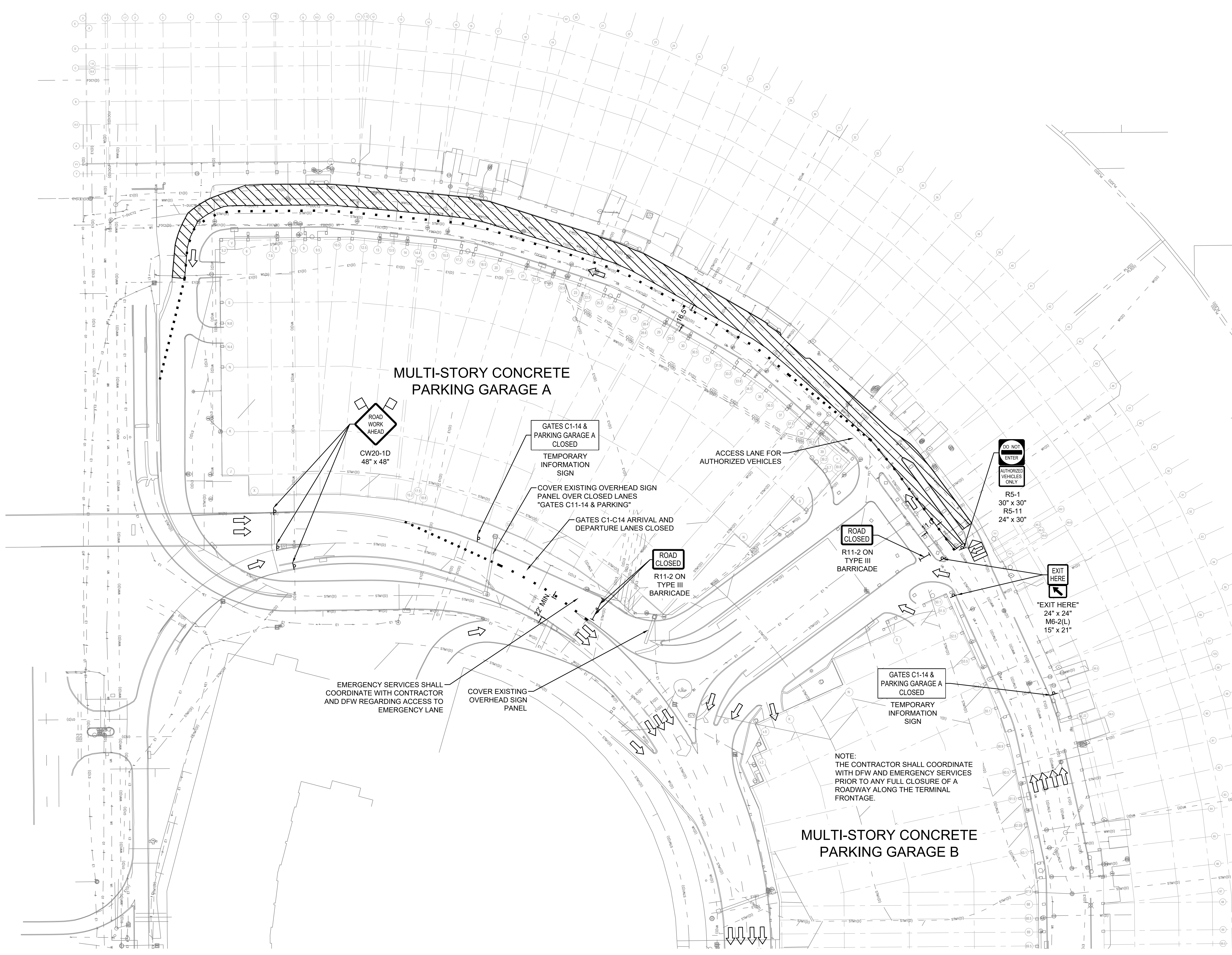

EXISTING LEGEND

• CRIADO CONTROL POINT	⊠ ELECTRIC PULL BOX
• IRON ROD FOUND	⊠ ELECTRIC METER
• BOLLARD	⊠ ELECTRIC BOX
• GAS METER	⊠ ELECTRIC RISER
⊠ TRAFFIC SIGNAL LIGHT	⊠ GROUND LIGHT
⊠ POLE	⊠ SIGN
⊠ TRAFFIC SIGNAL PULL BOX	⊠ GAS PUMP
⊠ TRAFFIC SIGNAL CONTROL BOX	⊠ FUEL TANK VENT
⊠ TELECOM SERVICE BOX	⊠ TREE
⊠ TELECOM PEDESTAL	⊠ BUSH
⊠ TELECOM MANHOLE	⊠ WASTE WATER CLEANOUT
⊠ CATV PEDESTAL	⊠ WASTE WATER MANHOLE
⊠ CATV JUNCTION BOX	⊠ STORM DRAIN MANHOLE
⊠ CATV APPURTENANCE	⊠ WATER VALVE
⊠ LIGHT POLE	⊠ IRRIGATION CONTROL VALVE
⊠ CATHODIC PROTECTION	⊠ SPRINKLER HEAD
⊠ FLAG POLE	⊠ SPIGOT
⊠ GENERIC MANHOLE	⊠ FIRE HYDRANT
⊠ POWER POLE	⊠ WATER METER
⊠ GUYWIRE	⊠ OVERHEAD UTILITY
⊠ ELECTRIC MANHOLE	⊠ OVERHEAD ELECTRIC

PROPOSED LEGEND

	WORK ZONE
	TRAFFIC FLOW ARROW
	CHANNELIZING DEVICE (FOLLOW TXDOT STANDARDS FOR DETAILS AND SPACING)
	TRAILER MOUNTED FLASHING ARROW BOARD
	TEMPORARY MOT SIGN
	TYPE III BARRICADE

- NOTES:
1. A TRAFFIC CONTROL PLAN IS REQUIRED FOR ALL PHASING OF THE TERMINAL C ROADWAYS, AND GARAGE RECONSTRUCTION. THE TCP MUST BE SUBMITTED 2 WEEKS PRIOR TO CONSTRUCTION TO AARON ESPINOSA WITH DFW REPRESENTATIVES APPROVAL. ALL TCP PLANS SHALL FOLLOW LATEST EDITION OF "TEXAS MANUAL ON UNIFORM TRAFFIC CONTROL DEVICES" (TMUTCD) ONCE THE TCP IS APPROVED WITH THE CONTRACTORS BARRICADE PLAN, THE PROJECT MANAGER, OR CONSTRUCTION MANAGER, AND CONTRACTOR MUST ATTEND THE WEEKLY MONDAY MORNING MEETINGS AT 10:00AM TO KEEP STAFF UPDATED ON THE CLOSURE STATUS. A DIRECT CONTACT DURING THE WORK ZONE CLOSURE MUST RESPOND ASAP IN CASE ANY SIGNS, CONES, OR PROBLEM THAT MAY OCCUR DURING THE CLOSURE.
 2. SEE LOWER ROADWAY PHASING SEQUENCING NOTES ON SHEET CT100-900R FOR ADDITIONAL DETAILS.

KEY PLAN

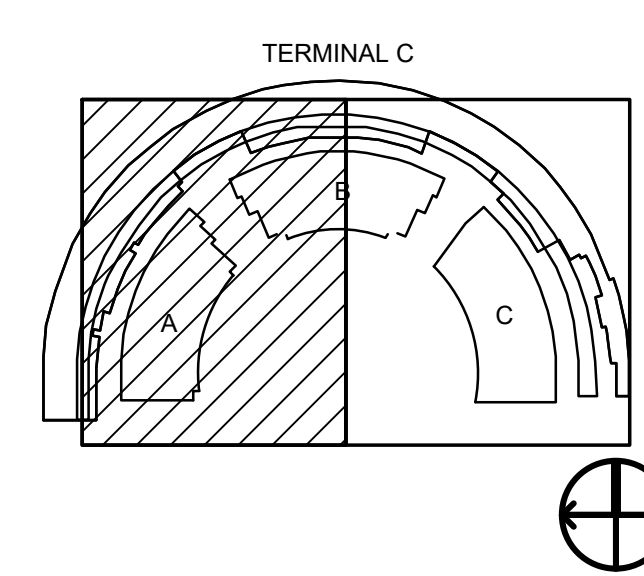

DFW DALLAS FORT WORTH INTERNATIONAL AIRPORT
 2330 N INTERNATIONAL PARKWAY
 DFW AIRPORT, TX 75261

ROBERT J. DEMING
 134776
 PROFESSIONAL ENGINEER

Primera
 Herrera, Ochoa & Krasbaum, Inc.
 777 North Meadows Street
 Suite 200, LB #
 Dallas, TX 75201
 (+1) 214 720 8000

DRAWN BY: JMR
 APPROVED BY: RJD
 ISSUE DATE: 2022-07-28
NOT FOR BID OR CONSTRUCTION

NO.	DATE	DESCRIPTION
2022-01-06	30% DESIGN	
2022-05-01	100% DESIGN	
2022-07-28	100% REVISED FOR PERMIT (RFP)	

TERMINAL C GARAGE & ROADWAYS
PHASE 3B MOT (LOWER ROADWAY)
 PROJECT NUMBER: TFD-007
 PERMIT NUMBER: B22-0023

SHEET NUMBER
CT111-900R

SCALE(S) AS NOTED ON THIS SHEET ARE BASED ON A FULL SIZE 30 X 42 SHEET.

BORDER RELEASE DATE: October 16, 2021
 01/22/2021 10:59:09 AM
 C:\Users\h3c2203\OneDrive\Documents\CTA - Terminal C Expansions\Program\Project Files\01_CTA - Terminal C Garages and Roadways\DWG\DFW-TC-CT112-001-MOT-Lower.dwg

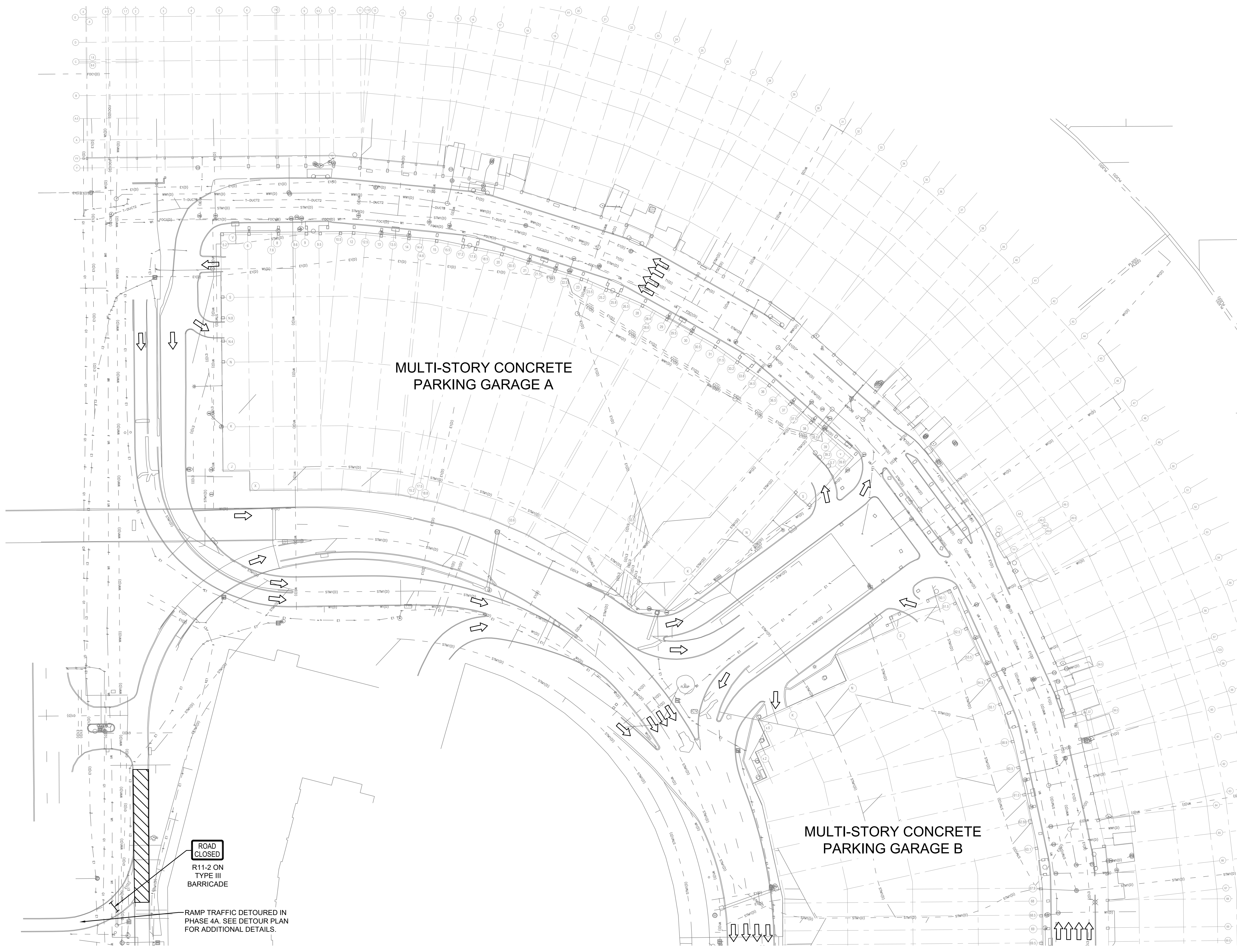

EXISTING LEGEND

•	CRICADO CONTROL POINT	⊠	ELECTRIC PULL BOX
•	IRON ROD FOUND	⊠	ELECTRIC METER
•	BOLLARD	⊠	ELECTRIC BOX
•	GAS METER	⊠	ELECTRIC RISER
⊠	TRAFFIC SIGNAL LIGHT	⊠	GROUND LIGHT
⊠	POLE	⊠	SIGN
⊠	TRAFFIC SIGNAL PULL BOX	⊠	GAS PUMP
⊠	TRAFFIC SIGNAL CONTROL BOX	⊠	FUEL TANK VENT
⊠	TELECOM SERVICE BOX	⊠	TREE
⊠	TELECOM PEDESTAL	⊠	BUSH
⊠	TELECOM MANHOLE	⊠	WASTE WATER CLEANOUT
⊠	CATV PEDESTAL	⊠	WASTE WATER MANHOLE
⊠	CATV JUNCTION BOX	⊠	STORM DRAIN MANHOLE
⊠	CATV APPURTENANCE	⊠	WATER VALVE
⊠	LIGHT POLE	⊠	IRRIGATION CONTROL VALVE
⊠	CATHODIC PROTECTION	⊠	SPRINKLER HEAD
⊠	FLAG POLE	⊠	SPIGOT
⊠	GENERIC MANHOLE	⊠	FIRE HYDRANT
⊠	POWER POLE	⊠	WATER METER
⊠	GUYWIRE	⊠	OVERHEAD UTILITY
⊠	ELECTRIC MANHOLE	⊠	OVERHEAD ELECTRIC

PROPOSED LEGEND

▨	WORK ZONE
→	TRAFFIC FLOW ARROW
⋯	CHANNELIZING DEVICE (FOLLOW TXDOT STANDARDS FOR DETAILS AND SPACING)
⊠	TRAILER MOUNTED FLASHING ARROW BOARD
⊠	TEMPORARY MOT SIGN
⊠	TYPE III BARRICADE

- NOTES:
1. A TRAFFIC CONTROL PLAN IS REQUIRED FOR ALL PHASING OF THE TERMINAL C ROADWAYS, AND GARAGE RECONSTRUCTION. THE TCP MUST BE SUBMITTED 2 WEEKS PRIOR TO CONSTRUCTION TO AARON ESPINOSA WITH DFW REPRESENTATIVES APPROVAL. ALL TCP PLANS SHALL FOLLOW LATEST EDITION OF "TEXAS MANUAL ON UNIFORM TRAFFIC CONTROL DEVICES" (TMUTCD) ONCE THE TCP IS APPROVED WITH THE CONTRACTORS BARRICADE PLAN, THE PROJECT MANAGER, OR CONSTRUCTION MANAGER, AND CONTRACTOR MUST ATTEND THE WEEKLY MONDAY MORNING MEETINGS AT 10:00AM TO KEEP STAFF UPDATED ON THE CLOSURE STATUS. A DIRECT CONTACT DURING THE WORK ZONE CLOSURE MUST RESPOND ASAP IN CASE ANY SIGNS, CONES, OR PROBLEM THAT MAY OCCUR DURING THE CLOSURE.
 2. SEE LOWER ROADWAY PHASING SEQUENCING NOTES ON SHEET CT100-900R FOR ADDITIONAL DETAILS.

KEY PLAN

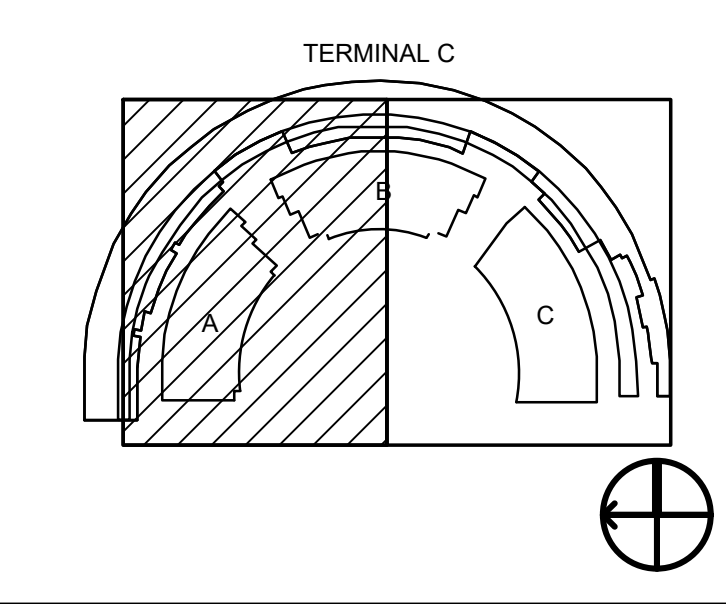

DALLAS FORT WORTH INTERNATIONAL AIRPORT
 2330 N INTERNATIONAL PARKWAY
 DFW AIRPORT, TX 75261

Primera
 Project Engineers, LLC
 300 West 7th
 Suite 211
 Dallas, TX 75201
 (+1) 214 720 8000

DRAWN BY: JMR
 APPROVED BY: RJD
 ISSUE DATE: 2022-07-28
NOT FOR BID OR CONSTRUCTION

NO.	DATE	DESCRIPTION
1	2022-07-28	100% DESIGN
2	2022-07-28	100% DESIGN FOR PERMIT (D/P)

TERMINAL C GARAGE & ROADWAYS
PHASE 4A MOT (LOWER ROADWAY)
 PROJECT NUMBER: TFD-007
 PERMIT NUMBER: B22-0023

SHEET NUMBER
CT112-900R

SCALE(S) AS NOTED ON THIS SHEET ARE BASED ON A FULL SIZE 30 X 42 SHEET.

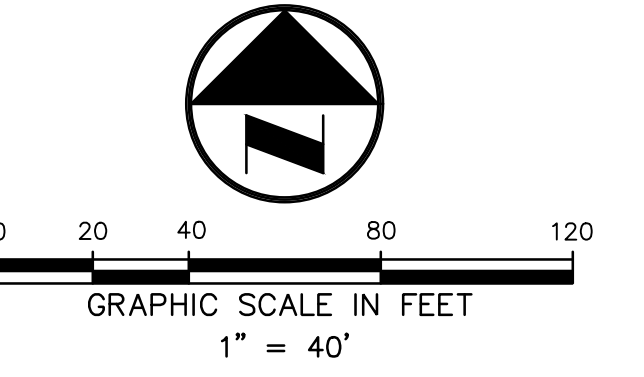

EXISTING LEGEND

- CRIADO CONTROL POINT
- IRON ROD FOUND
- BOLLARD
- GAS METER
- TRAFFIC SIGNAL LIGHT POLE
- TRAFFIC SIGNAL PULL BOX
- TRAFFIC SIGNAL CONTROL BOX
- TELECOM SERVICE BOX
- TELECOM PEDESTAL
- TELECOM MANHOLE
- CATV PEDESTAL
- CATV JUNCTION BOX
- CATV APPURTENANCE
- LIGHT POLE
- CATHODIC PROTECTION
- FLAG POLE
- GENERIC MANHOLE
- POWER POLE
- GUYWIRE
- ELECTRIC MANHOLE
- ELECTRIC PULL BOX
- ELECTRIC METER
- ELECTRIC BOX
- ELECTRIC RISER
- GROUND LIGHT SIGN
- GAS PUMP
- FUEL TANK VENT
- TREE
- BUSH
- WASTE WATER CLEANOUT
- WASTE WATER MANHOLE
- STORM DRAIN MANHOLE
- WATER VALVE
- IRRIGATION CONTROL VALVE
- SPRINKLER HEAD
- SPIGOT
- FIRE HYDRANT
- WATER METER
- OVERHEAD UTILITY
- OVERHEAD ELECTRIC

PROPOSED LEGEND

- WORK ZONE
- TRAFFIC FLOW ARROW
- CHANNELIZING DEVICE (FOLLOW TXDOT STANDARDS FOR DETAILS AND SPACING)
- TRAILER MOUNTED FLASHING ARROW BOARD
- TEMPORARY MOT SIGN
- TYPE III BARRICADE

NOTES:

1. A TRAFFIC CONTROL PLAN IS REQUIRED FOR ALL PHASING OF THE TERMINAL C ROADWAYS, AND GARAGE RECONSTRUCTION. THE TCP MUST BE SUBMITTED 2 WEEKS PRIOR TO CONSTRUCTION TO AARON ESPINOSA WITH DFW REPRESENTATIVES APPROVAL. ALL TCP PLANS SHALL FOLLOW LATEST EDITION OF "TEXAS MANUAL ON UNIFORM TRAFFIC CONTROL DEVICES" (TMUTCD) ONCE THE TCP IS APPROVED WITH THE CONTRACTORS BARRICADE PLAN, THE PROJECT MANAGER, OR CONSTRUCTION MANAGER, AND CONTRACTOR MUST ATTEND THE WEEKLY MONDAY MORNING MEETINGS AT 10:00AM TO KEEP STAFF UPDATED ON THE CLOSURE STATUS. A DIRECT CONTACT DURING THE WORK ZONE CLOSURE MUST RESPOND ASAP IN CASE ANY SIGNS, CONES, OR PROBLEM THAT MAY OCCUR DURING THE CLOSURE.
2. UPPER LEVEL STAGES TO OCCUR DURING PHASE 3.
3. SEE UPPER ROADWAY PHASING SEQUENCING NOTES ON SHEET CT100-900R FOR ADDITIONAL DETAILS.

KEY PLAN

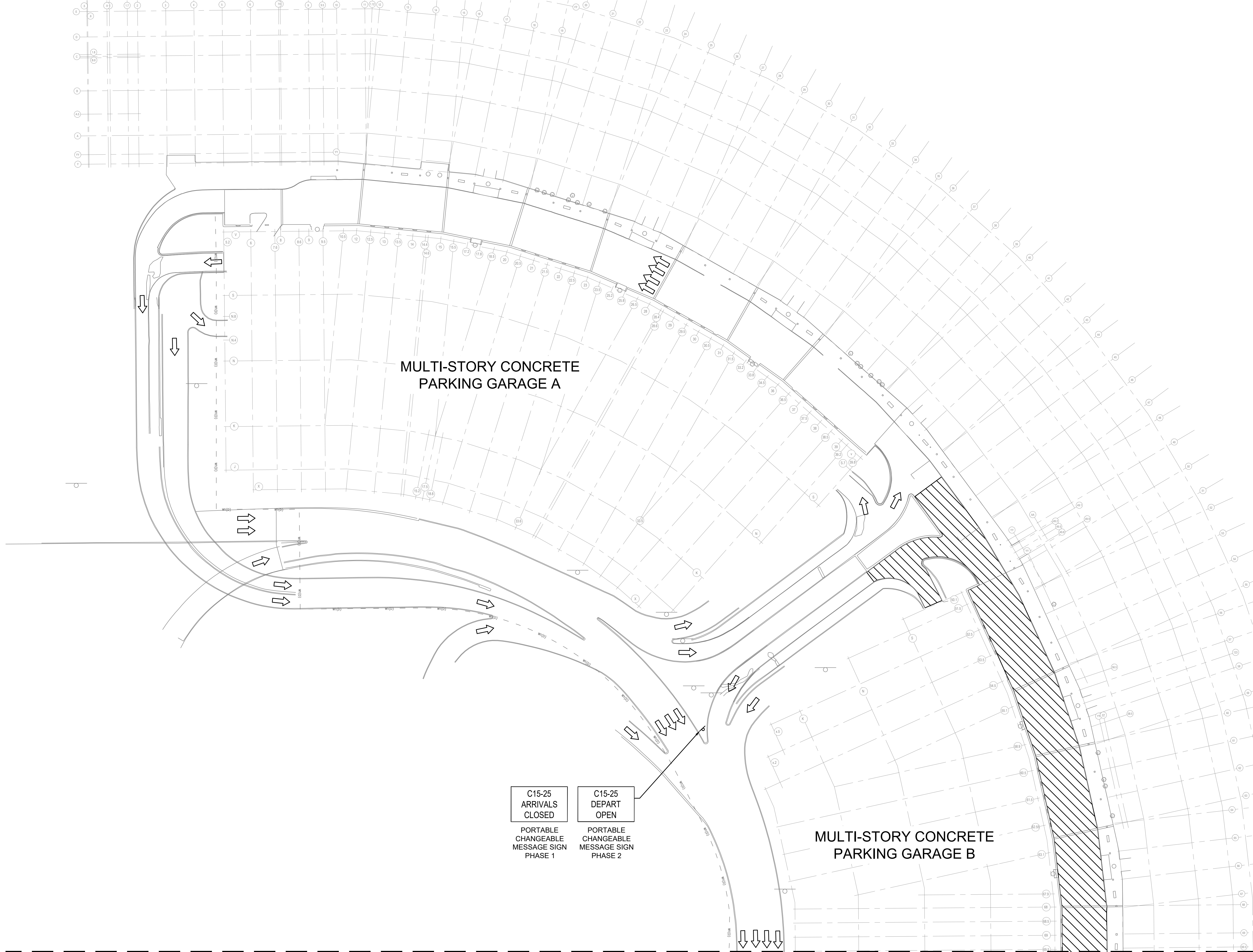
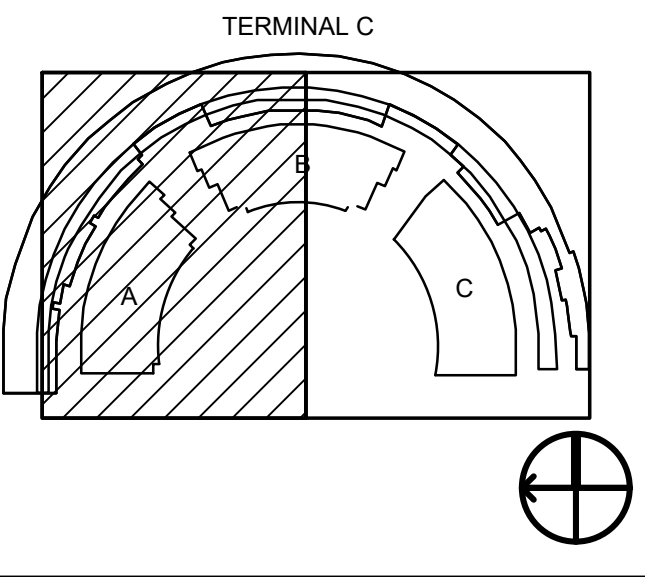

C15-25
ARRIVALS
CLOSED
PORTABLE
CHANGEABLE
MESSAGE SIGN
PHASE 1

C15-25
DEPART
OPEN
PORTABLE
CHANGEABLE
MESSAGE SIGN
PHASE 2

MATCHLINE - SEE SHEET CT116-900R

BORDER RELEASE DATE: October 16, 2021
01/22/2021 14:50:09
C:\Users\h3c2c3\OneDrive\Documents\HOK\DAL\DFW\Int'l Airport - CTA Expansion Program\Project Files\01_CTA - Terminal C Garages and Roadways\DWG-TC-CT114-900R-MOT Upper.dwg

DALLAS
FORT WORTH
INTERNATIONAL
AIRPORT

2330 N INTERNATIONAL PARKWAY
DFW AIRPORT, TX 75261

Primera

Professional Engineers, Ltd.
300 West 7th
Suite 211
Dallas, TX 75201
+1 214 720 8000

DRAWN BY: JMR
APPROVED BY: RJD
ISSUE DATE: 2022-07-28

NOT FOR BID OR CONSTRUCTION

NO.	DATE	DESCRIPTION
1	2022-07-28	100% DESIGN
2	2022-07-28	100% DESIGN FOR PERMIT (DPP)

TERMINAL C GARAGE & ROADWAYS
STAGE 2 MOT (UPPER ROADWAY)

PROJECT NUMBER: TFD-007

PERMIT NUMBER: B22-0023

SHEET NUMBER
CT115-900R

SCALE(S) AS NOTED ON THIS SHEET ARE BASED ON A FULL SIZE 30 X 42 SHEET.

MATCHLINE - SEE SHEET CT115-900R

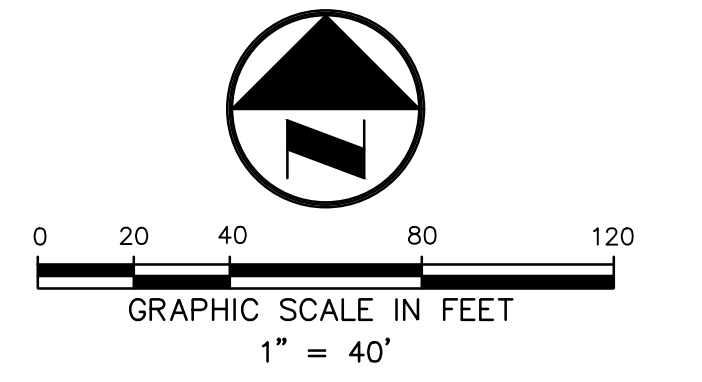

EXISTING LEGEND

- CRIADO CONTROL POINT
- IRON ROD FOUND
- BOLLARD
- GAS METER
- TRAFFIC SIGNAL LIGHT POLE
- TRAFFIC SIGNAL PULL BOX
- TRAFFIC SIGNAL CONTROL BOX
- TELECOM SERVICE BOX
- TELECOM PEDESTAL
- TELECOM MANHOLE
- CATV PEDESTAL
- CATV JUNCTION BOX
- CATV APPURTENANCE
- LIGHT POLE
- CATHODIC PROTECTION
- FLAG POLE
- GENERIC MANHOLE
- POWER POLE
- GUYWIRE
- ELECTRIC MANHOLE
- ELECTRIC PULL BOX
- ELECTRIC METER
- ELECTRIC BOX
- ELECTRIC RISER
- GROUND LIGHT SIGN
- GAS PUMP
- FUEL TANK VENT
- TREE
- BUSH
- WASTE WATER CLEANOUT
- WASTE WATER MANHOLE
- STORM DRAIN MANHOLE
- WATER VALVE
- IRRIGATION CONTROL VALVE
- SPRINKLER HEAD
- SPIGOT
- FIRE HYDRANT
- WATER METER
- OVERHEAD UTILITY
- OVERHEAD ELECTRIC

PROPOSED LEGEND

- WORK ZONE
- TRAFFIC FLOW ARROW
- CHANNELIZING DEVICE (FOLLOW TXDOT STANDARDS FOR DETAILS AND SPACING)
- TRAILER MOUNTED FLASHING ARROW BOARD
- TEMPORARY MOT SIGN
- TYPE III BARRICADE

NOTES:

1. A TRAFFIC CONTROL PLAN IS REQUIRED FOR ALL PHASING OF THE TERMINAL C ROADWAYS, AND GARAGE RECONSTRUCTION. THE TCP MUST BE SUBMITTED 2 WEEKS PRIOR TO CONSTRUCTION TO AARON ESPINOSA WITH DFW REPRESENTATIVES APPROVAL. ALL TCP PLANS SHALL FOLLOW LATEST EDITION OF "TEXAS MANUAL ON UNIFORM TRAFFIC CONTROL DEVICES" (TMUTCD) ONCE THE TCP IS APPROVED WITH THE CONTRACTORS BARRICADE PLAN, THE PROJECT MANAGER, OR CONSTRUCTION MANAGER, AND CONTRACTOR MUST ATTEND THE WEEKLY MONDAY MORNING MEETINGS AT 10:00AM TO KEEP STAFF UPDATED ON THE CLOSURE STATUS. A DIRECT CONTACT DURING THE WORK ZONE CLOSURE MUST RESPOND ASAP IN CASE ANY SIGNS, CONES, OR PROBLEM THAT MAY OCCUR DURING THE CLOSURE.
2. UPPER LEVEL STAGES TO OCCUR DURING PHASE 3.
3. SEE UPPER ROADWAY PHASING SEQUENCING NOTES ON SHEET CT100-900R FOR ADDITIONAL DETAILS.

MULTI-STORY CONCRETE PARKING GARAGE B

ROAD CLOSED
R11-2 ON
TYPE III
BARRICADE

ROAD CLOSED
R11-2 ON
TYPE III
BARRICADE

KEY PLAN

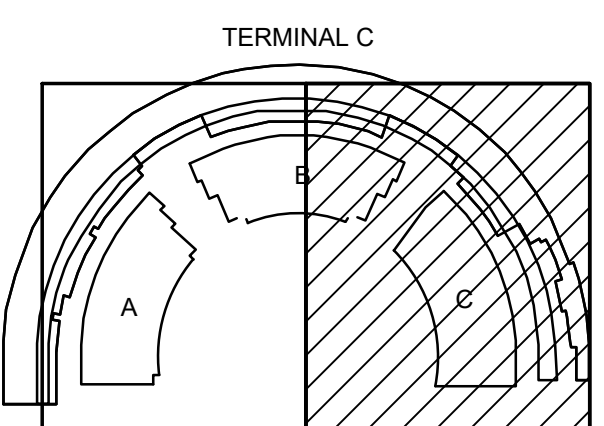

BORDER RELEASE DATE: October 16, 2021
01/20/2021 14:59:09
C:\Users\hrc2\OneDrive\Documents\HOK\DAL\DFW Int'l Airport - CTA Expansion Program\Project Files\01_CTA - Terminal C Garages and Roadways\CE/01 - CAD/Sheets\85000852.DWG-TC-CT114-900R.MDT\tpwr.dwg



DALLAS
FORT WORTH
INTERNATIONAL
AIRPORT

2330 N INTERNATIONAL PARKWAY
DFW AIRPORT, TX 75261

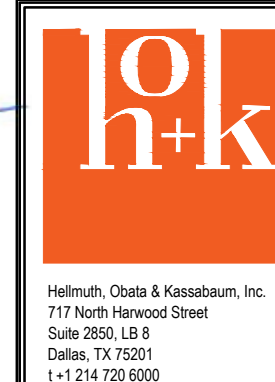
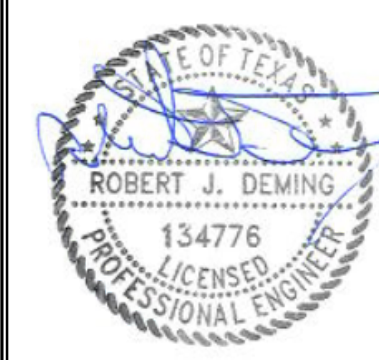

Primera Engineers, LLC
300 West 7th
Suite 210
Dallas, TX 75201
+1 214 720 8000

DRAWN BY: JMR
APPROVED BY: RJD
ISSUE DATE: 2022-07-28
NOT FOR BID OR CONSTRUCTION

NO.	DATE	DESCRIPTION
1	2022-07-28	100% DESIGN
2	2022-07-28	100% DESIGN FOR PERMIT (DPP)

PROJECT NUMBER: TFD-007

TERMINAL C GARAGE & ROADWAYS
STAGE 2 MOT (UPPER ROADWAY)

PERMIT NUMBER: B22-0023

SHEET NUMBER
CT116-900R

SCALE(S) AS NOTED ON THIS SHEET ARE BASED ON A FULL SIZE 30 X 42 SHEET.

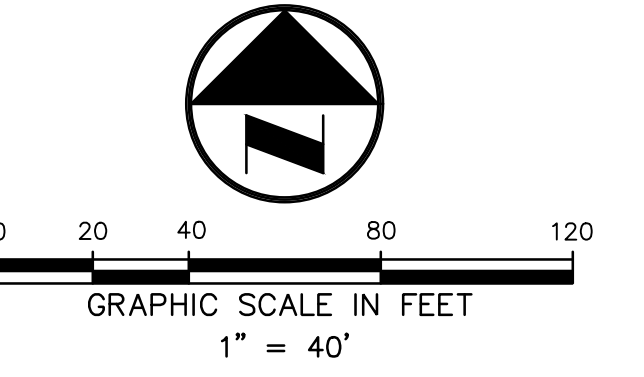

EXISTING LEGEND

- CRIADO CONTROL POINT
- IRON ROD FOUND
- BOLLARD
- GAS METER
- TRAFFIC SIGNAL LIGHT POLE
- TRAFFIC SIGNAL PULL BOX
- TRAFFIC SIGNAL CONTROL BOX
- TELECOM SERVICE BOX
- TELECOM PEDESTAL
- TELECOM MANHOLE
- CATV PEDESTAL
- CATV JUNCTION BOX
- CATV APPURTENANCE
- LIGHT POLE
- CATHODIC PROTECTION
- FLAG POLE
- GENERIC MANHOLE
- POWER POLE
- GUYWIRE
- ELECTRIC MANHOLE
- ELECTRIC PULL BOX
- ELECTRIC METER
- ELECTRIC BOX
- ELECTRIC RISER
- GROUND LIGHT SIGN
- GAS PUMP
- FUEL TANK VENT
- TREE
- BUSH
- WASTE WATER CLEANOUT
- WASTE WATER MANHOLE
- STORM DRAIN MANHOLE
- WATER VALVE
- IRRIGATION CONTROL VALVE
- SPRINKLER HEAD
- SPIGOT
- FIRE HYDRANT
- WATER METER
- OVERHEAD UTILITY
- OVERHEAD ELECTRIC

PROPOSED LEGEND

- WORK ZONE
- TRAFFIC FLOW ARROW
- CHANNELIZING DEVICE (FOLLOW TXDOT STANDARDS FOR DETAILS AND SPACING)
- TRAILER MOUNTED FLASHING ARROW BOARD
- TEMPORARY MOT SIGN
- TYPE III BARRICADE

NOTES:

1. A TRAFFIC CONTROL PLAN IS REQUIRED FOR ALL PHASING OF THE TERMINAL C ROADWAYS, AND GARAGE RECONSTRUCTION. THE TCP MUST BE SUBMITTED 2 WEEKS PRIOR TO CONSTRUCTION TO AARON ESPINOSA WITH DFW REPRESENTATIVES APPROVAL. ALL TCP PLANS SHALL FOLLOW LATEST EDITION OF "TEXAS MANUAL ON UNIFORM TRAFFIC CONTROL DEVICES" (TMUTCD) ONCE THE TCP IS APPROVED WITH THE CONTRACTORS BARRICADE PLAN, THE PROJECT MANAGER, OR CONSTRUCTION MANAGER, AND CONTRACTOR MUST ATTEND THE WEEKLY MONDAY MORNING MEETINGS AT 10:00AM TO KEEP STAFF UPDATED ON THE CLOSURE STATUS. A DIRECT CONTACT DURING THE WORK ZONE CLOSURE MUST RESPOND ASAP IN CASE ANY SIGNS, CONES, OR PROBLEM THAT MAY OCCUR DURING THE CLOSURE.
2. UPPER LEVEL STAGES TO OCCUR DURING PHASE 3.
3. SEE UPPER ROADWAY PHASING SEQUENCING NOTES ON SHEET CT1100-900R FOR ADDITIONAL DETAILS.

KEY PLAN

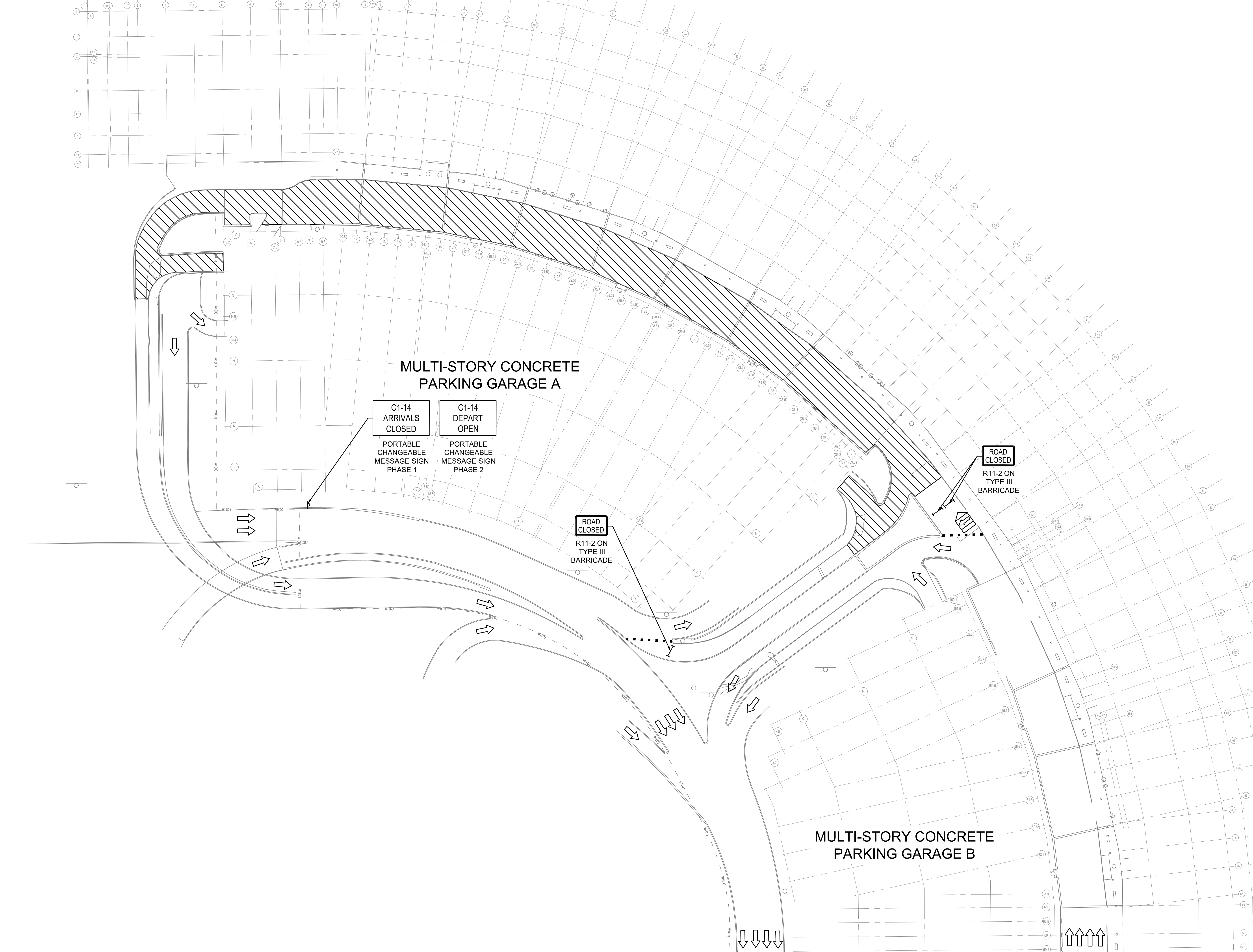
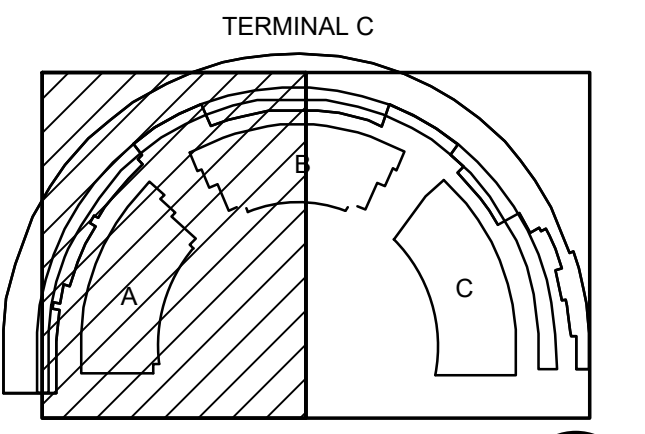

BORDER RELEASE DATE: October 16, 2021
 01/20/2021 14:50:09 PLOTTED C:\Users\hok\OneDrive\Documents\HOK\DAL\DFW\Int'l Airport - CTA Expansion Program\Project Files\01_CTA - Terminal C Garages and Roadways\DWG\CT114-900R.MDT\Upper.dwg



DALLAS
FORT WORTH
INTERNATIONAL
AIRPORT

2330 N INTERNATIONAL PARKWAY
DFW AIRPORT, TX 75261



Hobas, Clark & Kneass, Inc.
717 South Meadows Drive
Dallas, TX 75201
+1 214 720 8000



Primera Engineers, LLC
300 West 7th
Suite 211
Dallas, TX 75201
+1 214 606 0910

DRAWN BY: JMR
 APPROVED BY: RJD
 ISSUE DATE: 2022-07-28

NOT FOR BID OR CONSTRUCTION

NO.	DATE	DESCRIPTION
1	2022-09-01	100% DESIGN
2	2022-07-28	100% DESIGN FOR PERMIT (DPP)

TERMINAL C GARAGE & ROADWAYS
STAGE 3 MOT (UPPER ROADWAY)

PROJECT NUMBER: TFD-007

PERMIT NUMBER: B22-0023

SHEET NUMBER
CT117-900R

SCALE(S) AS NOTED ON THIS SHEET ARE BASED ON A FULL SIZE 30 X 42 SHEET.

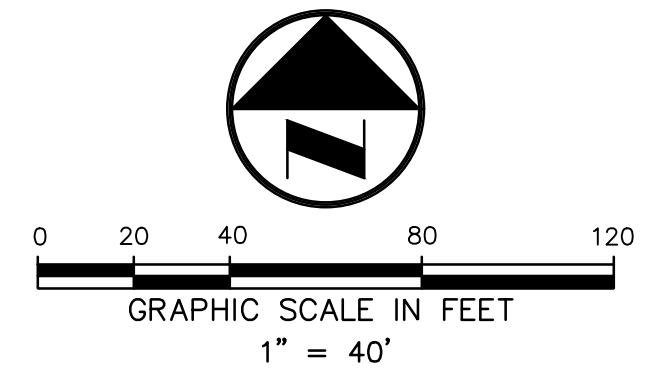

EXISTING LEGEND

- CRIADO CONTROL POINT
- IRON ROD FOUND
- BOLLARD
- GAS METER
- TRAFFIC SIGNAL LIGHT POLE
- TRAFFIC SIGNAL PULL BOX
- TRAFFIC SIGNAL CONTROL BOX
- TELECOM SERVICE BOX
- TELECOM PEDESTAL
- CATV PEDESTAL
- CATV JUNCTION BOX
- CATV APPURTENANCE
- LIGHT POLE
- CATHODIC PROTECTION
- FLAG POLE
- GENERIC MANHOLE
- POWER POLE
- GUYWIRE
- ELECTRIC MANHOLE
- ELECTRIC PULL BOX
- ELECTRIC METER
- ELECTRIC BOX
- ELECTRIC RISER
- GROUND LIGHT SIGN
- GAS PUMP
- FUEL TANK VENT
- TREE
- BUSH
- WASTE WATER CLEANOUT
- WASTE WATER MANHOLE
- STORM DRAIN MANHOLE
- WATER VALVE
- IRRIGATION CONTROL VALVE
- SPRINKLER HEAD
- SPIGOT
- FIRE HYDRANT
- WATER METER
- OVERHEAD UTILITY
- OVERHEAD ELECTRIC

PROPOSED LEGEND

- WORK ZONE
- TRAFFIC FLOW ARROW
- CHANNELIZING DEVICE (FOLLOW TXDOT STANDARDS FOR DETAILS AND SPACING)
- TRAILER MOUNTED FLASHING ARROW BOARD
- TEMPORARY MOT SIGN
- TYPE III BARRICADE

NOTES:

1. A TRAFFIC CONTROL PLAN IS REQUIRED FOR ALL PHASING OF THE TERMINAL C ROADWAYS, AND GARAGE RECONSTRUCTION. THE TCP MUST BE SUBMITTED 2 WEEKS PRIOR TO CONSTRUCTION TO AARON ESPINOSA WITH DFW REPRESENTATIVES APPROVAL. ALL TCP PLANS SHALL FOLLOW LATEST EDITION OF "TEXAS MANUAL ON UNIFORM TRAFFIC CONTROL DEVICES" (TMUTCD) ONCE THE TCP IS APPROVED WITH THE CONTRACTORS BARRICADE PLAN, THE PROJECT MANAGER, OR CONSTRUCTION MANAGER, AND CONTRACTOR MUST ATTEND THE WEEKLY MONDAY MORNING MEETINGS AT 10:00AM TO KEEP STAFF UPDATED ON THE CLOSURE STATUS. A DIRECT CONTACT DURING THE WORK ZONE CLOSURE MUST RESPOND ASAP IN CASE ANY SIGNS, CONES, OR PROBLEM THAT MAY OCCUR DURING THE CLOSURE.
2. UPPER LEVEL STAGES TO OCCUR DURING PHASE 3.
3. SEE UPPER ROADWAY PHASING SEQUENCING NOTES ON SHEET CT1100-900R FOR ADDITIONAL DETAILS.

KEY PLAN

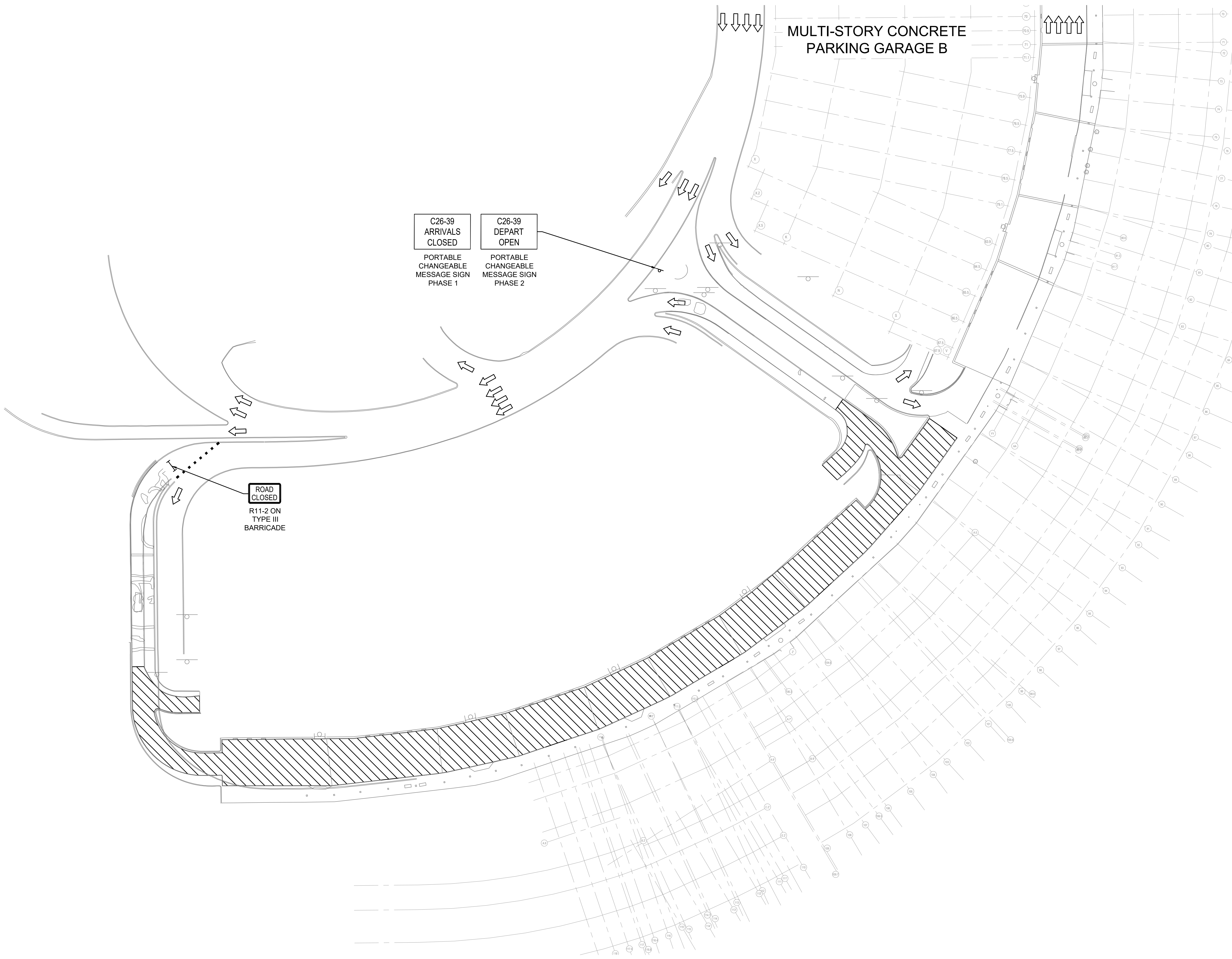
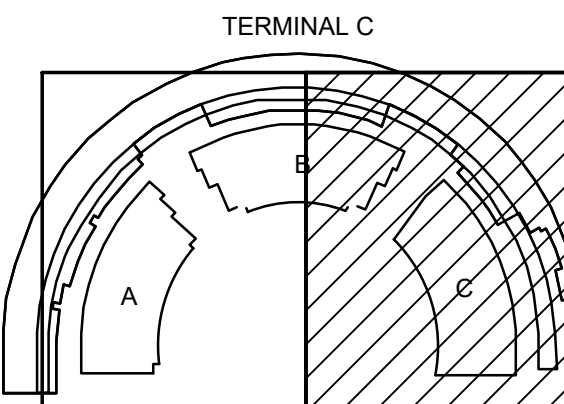

BORDER RELEASE DATE: October 16, 2021
 01/20/2021 14:59:09
 C:\Users\jrc2023\OneDrive\Documents\DFW\DFW Int'l Airport - CTA Expansion Program\Project Files\01_CTA - Terminal C Garages and Roadways\CE/01 - CAD/Sheets/010000/DFW-TC-CT114-900R.MDT\ipwr.dwg

DFW DALLAS FORT WORTH INTERNATIONAL AIRPORT

2330 N INTERNATIONAL PARKWAY
DFW AIRPORT, TX 75261

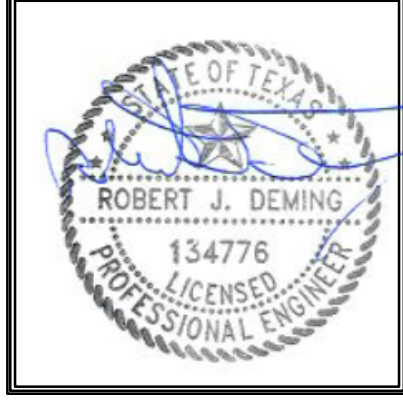

h+k Primera

Heidi-John, Chas & Kaseyann, Inc.
717 South Central Street
Suite 200, LB #
Dallas, TX 75201
+1 214 720 8000

Primera Engineers, LLC
300 West 7th
Suite 211
Dallas, TX 75201
+1 214 696 0910

DRAWN BY: JMR
APPROVED BY: RJD
ISSUE DATE: 2022-07-28

NOT FOR BID OR CONSTRUCTION

NO.	DATE	DESCRIPTION
1	2022-09-01	100% DESIGN
2	2022-07-28	100% ISSUED FOR PERMIT (IFP)

TERMINAL C GARAGE & ROADWAYS
STAGE 6 MOT (UPPER ROADWAY)

PROJECT NUMBER: TFD-007

PERMIT NUMBER: B22-0023

SHEET NUMBER
CT118-900R

SCALE(S) AS NOTED ON THIS SHEET ARE BASED ON A FULL SIZE 30 X 42 SHEET.

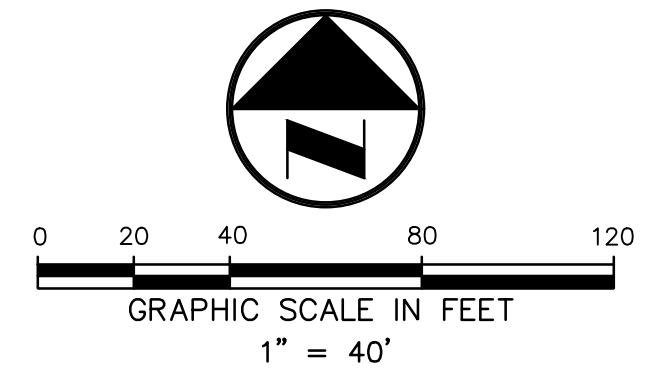

EXISTING LEGEND

- CRIADO CONTROL POINT
- IRON ROD FOUND
- BOLLARD
- GAS METER
- TRAFFIC SIGNAL LIGHT POLE
- TRAFFIC SIGNAL PULL BOX
- TRAFFIC SIGNAL CONTROL BOX
- TELECOM SERVICE BOX
- TELECOM PEDESTAL
- TELECOM MANHOLE
- CATV PEDESTAL
- CATV JUNCTION BOX
- CATV APPURTENANCE
- LIGHT POLE
- CATHODIC PROTECTION
- FLAG POLE
- GENERIC MANHOLE
- POWER POLE
- GUYWIRE
- ELECTRIC MANHOLE
- ELECTRIC PULL BOX
- ELECTRIC METER
- ELECTRIC BOX
- ELECTRIC RISER
- GROUND LIGHT SIGN
- GAS PUMP
- FUEL TANK VENT
- TREE
- BUSH
- WASTE WATER CLEANOUT
- WASTE WATER MANHOLE
- STORM DRAIN MANHOLE
- WATER VALVE
- IRRIGATION CONTROL VALVE
- SPRINKLER HEAD
- SPIGOT
- FIRE HYDRANT
- WATER METER
- OVERHEAD UTILITY
- OVERHEAD ELECTRIC

PROPOSED LEGEND

- WORK ZONE
- TRAFFIC FLOW ARROW
- CHANNELIZING DEVICE (FOLLOW TXDOT STANDARDS FOR DETAILS AND SPACING)
- TRAILER MOUNTED FLASHING ARROW BOARD
- TEMPORARY MOT SIGN
- TYPE III BARRICADE

NOTES:

1. A TRAFFIC CONTROL PLAN IS REQUIRED FOR ALL PHASING OF THE TERMINAL C ROADWAYS, AND GARAGE RECONSTRUCTION. THE TCP MUST BE SUBMITTED 2 WEEKS PRIOR TO CONSTRUCTION TO AARON ESPINOSA WITH DFW REPRESENTATIVES APPROVAL. ALL TCP PLANS SHALL FOLLOW LATEST EDITION OF "TEXAS MANUAL ON UNIFORM TRAFFIC CONTROL DEVICES" (TMUTCD) ONCE THE TCP IS APPROVED WITH THE CONTRACTORS BARRICADE PLAN, THE PROJECT MANAGER, OR CONSTRUCTION MANAGER, AND CONTRACTOR MUST ATTEND THE WEEKLY MONDAY MORNING MEETINGS AT 10:00AM TO KEEP STAFF UPDATED ON THE CLOSURE STATUS. A DIRECT CONTACT DURING THE WORK ZONE CLOSURE MUST RESPOND ASAP IN CASE ANY SIGNS, CONES, OR PROBLEM THAT MAY OCCUR DURING THE CLOSURE.
2. UPPER LEVEL STAGES TO OCCUR DURING PHASE 3.
3. SEE UPPER ROADWAY PHASING SEQUENCING NOTES ON SHEET CT100-900R FOR ADDITIONAL DETAILS.

KEY PLAN

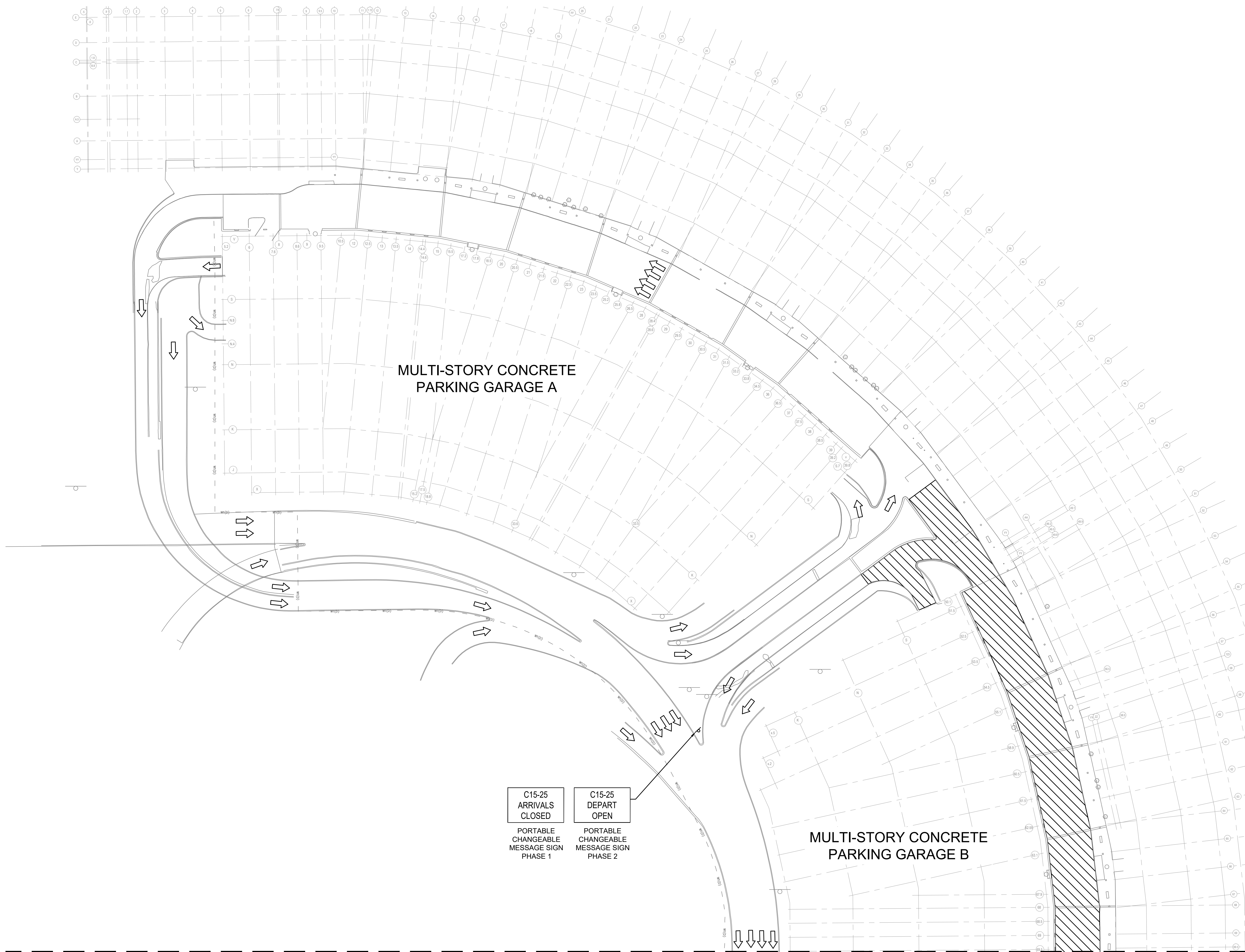
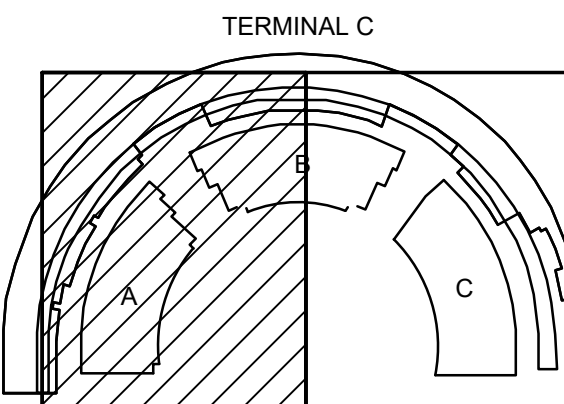

C15-25 ARRIVALS CLOSED
PORTABLE CHANGEABLE MESSAGE SIGN PHASE 1

C15-25 DEPART OPEN
PORTABLE CHANGEABLE MESSAGE SIGN PHASE 2

MATCHLINE - SEE SHEET CT120-900R

BORDER RELEASE DATE: October 16, 2021
01/20/2021 14:50:09
C:\Users\h3c2c3\OneDrive\Documents\HOK\DAL\DFW\Int'l Airport - CTA Expansion Program\Project Files\01_CTA - Terminal C Garages and Roadways\DWG-TC-CT114-900R-MOT Upper.dwg

DALLAS FORT WORTH INTERNATIONAL AIRPORT

2330 N INTERNATIONAL PARKWAY
DFW AIRPORT, TX 75261

Heidolph, Ochs & Krasemann, Inc.
717 South Meadows Drive
Dallas, TX 75201
+1 214 720 8000

Primera Engineers, LLC
300 West 7th
Suite 211
Olivewood, TX 75051
+1 512 606 0910

DRAWN BY: JMR
APPROVED BY: RJD
ISSUE DATE: 2022-07-28

NOT FOR BID OR CONSTRUCTION

NO.	DATE	DESCRIPTION
1	2022-07-28	100% DESIGN
2	2022-07-28	100% DESIGN FOR PERMIT (DFP)

TERMINAL C GARAGE & ROADWAYS

STAGE 7 MOT (UPPER ROADWAY)

PROJECT NUMBER: TFD-007

PERMIT NUMBER: B22-0023

SHEET NUMBER
CT119-900R

SCALE(S) AS NOTED ON THIS SHEET ARE BASED ON A FULL SIZE 30 X 42 SHEET.

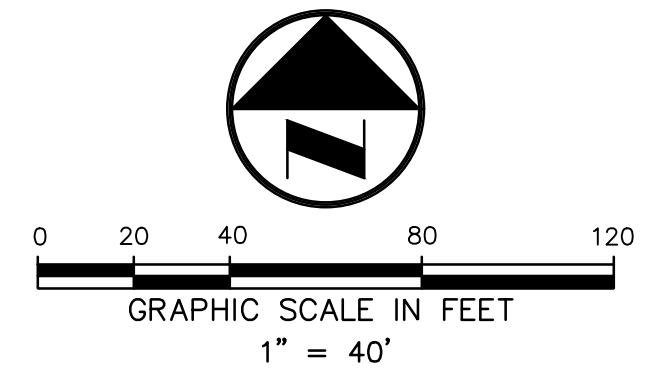

EXISTING LEGEND

- CRIADO CONTROL POINT
- IRON ROD FOUND
- BOLLARD
- GAS METER
- TRAFFIC SIGNAL LIGHT POLE
- TRAFFIC SIGNAL PULL BOX
- TRAFFIC SIGNAL CONTROL BOX
- TELECOM SERVICE BOX
- TELECOM PEDESTAL
- TELECOM MANHOLE
- CATV PEDESTAL
- CATV JUNCTION BOX
- CATV APPURTENANCE
- LIGHT POLE
- CATHODIC PROTECTION
- FLAG POLE
- GENERIC MANHOLE
- POWER POLE
- GUYWIRE
- ELECTRIC MANHOLE
- ELECTRIC PULL BOX
- ELECTRIC METER
- ELECTRIC BOX
- ELECTRIC RISER
- GROUND LIGHT SIGN
- GAS PUMP
- FUEL TANK VENT
- TREE
- BUSH
- WASTE WATER CLEANOUT
- WASTE WATER MANHOLE
- STORM DRAIN MANHOLE
- WATER VALVE
- IRRIGATION CONTROL VALVE
- SPRINKLER HEAD
- SPIGOT
- FIRE HYDRANT
- WATER METER
- OVERHEAD UTILITY
- OVERHEAD ELECTRIC

PROPOSED LEGEND

- WORK ZONE
- TRAFFIC FLOW ARROW
- CHANNELIZING DEVICE (FOLLOW TXDOT STANDARDS FOR DETAILS AND SPACING)
- TRAILER MOUNTED FLASHING ARROW BOARD
- TEMPORARY MOT SIGN
- TYPE III BARRICADE

NOTES:

1. A TRAFFIC CONTROL PLAN IS REQUIRED FOR ALL PHASING OF THE TERMINAL C ROADWAYS, AND GARAGE RECONSTRUCTION. THE TCP MUST BE SUBMITTED 2 WEEKS PRIOR TO CONSTRUCTION TO AARON ESPINOSA WITH DFW REPRESENTATIVES APPROVAL. ALL TCP PLANS SHALL FOLLOW LATEST EDITION OF "TEXAS MANUAL ON UNIFORM TRAFFIC CONTROL DEVICES" (TMUTCD) ONCE THE TCP IS APPROVED WITH THE CONTRACTORS BARRICADE PLAN, THE PROJECT MANAGER, OR CONSTRUCTION MANAGER, AND CONTRACTOR MUST ATTEND THE WEEKLY MONDAY MORNING MEETINGS AT 10:00AM TO KEEP STAFF UPDATED ON THE CLOSURE STATUS. A DIRECT CONTACT DURING THE WORK ZONE CLOSURE MUST RESPOND ASAP IN CASE ANY SIGNS, CONES, OR PROBLEM THAT MAY OCCUR DURING THE CLOSURE.
2. UPPER LEVEL STAGES TO OCCUR DURING PHASE 3.
3. SEE UPPER ROADWAY PHASING SEQUENCING NOTES ON SHEET CT1100-900R FOR ADDITIONAL DETAILS.

KEY PLAN

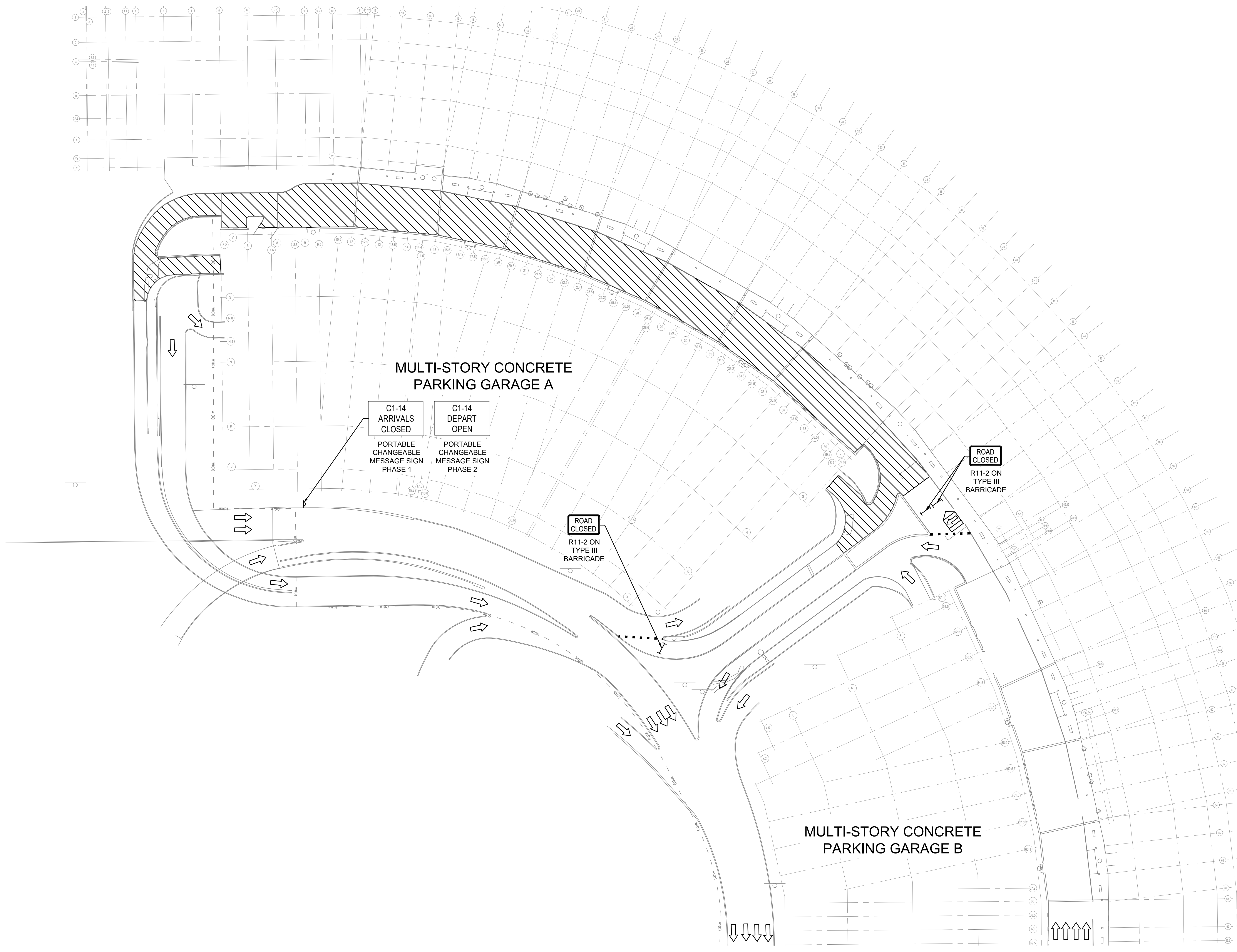
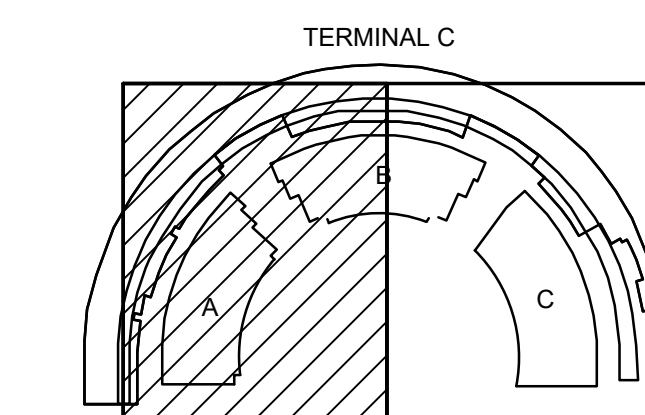

BORDER RELEASE DATE: October 16, 2021
 01/20/2021 14:50:09
 C:\Users\hok\OneDrive\Documents\HOK\DAL\DFW\Int'l Airport - CTA Expansion Program\Project Files\01_CTA - Terminal C Garages and Roadways\CE/01 - CAD/Sheets/800/082-DFW-TC-CT114-900R-MOT Upper.dwg



2330 N INTERNATIONAL PARKWAY
DFW AIRPORT, TX 75261

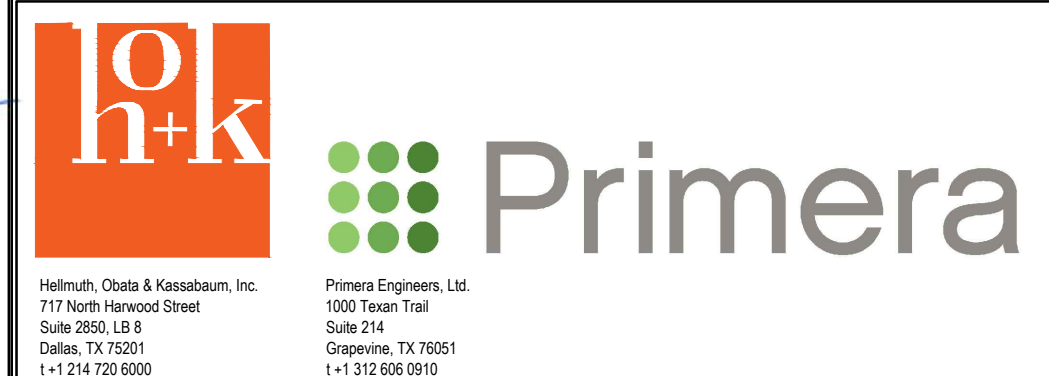
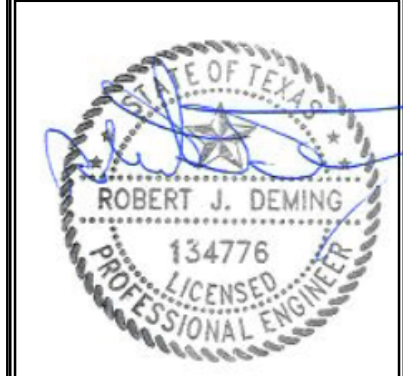

DRAWN BY: JMR
 APPROVED BY: RJD
 ISSUE DATE: 2022-07-28
NOT FOR BID OR CONSTRUCTION

NO.	DATE	DESCRIPTION
1	2022-07-28	100% DESIGN
2	2022-07-28	100% DESIGN FOR PERMIT (DPP)

TERMINAL C GARAGE & ROADWAYS
STAGE 8 MOT (UPPER ROADWAY)
 PROJECT NUMBER: TFD-007
 PERMIT NUMBER: B22-0023

SHEET NUMBER
CT121-900R

SCALE(S) AS NOTED ON THIS SHEET ARE BASED ON A FULL SIZE 30 X 42 SHEET.

DISCLAIMER: The use of this standard is governed by the "Texas Engineering Practice Act". No warranty of any kind is made by TxDOT for any purpose whatsoever. TxDOT assumes no responsibility for the conversion of this standard to other formats or for incorrect results or damages resulting from its use.

DATE: FILE:

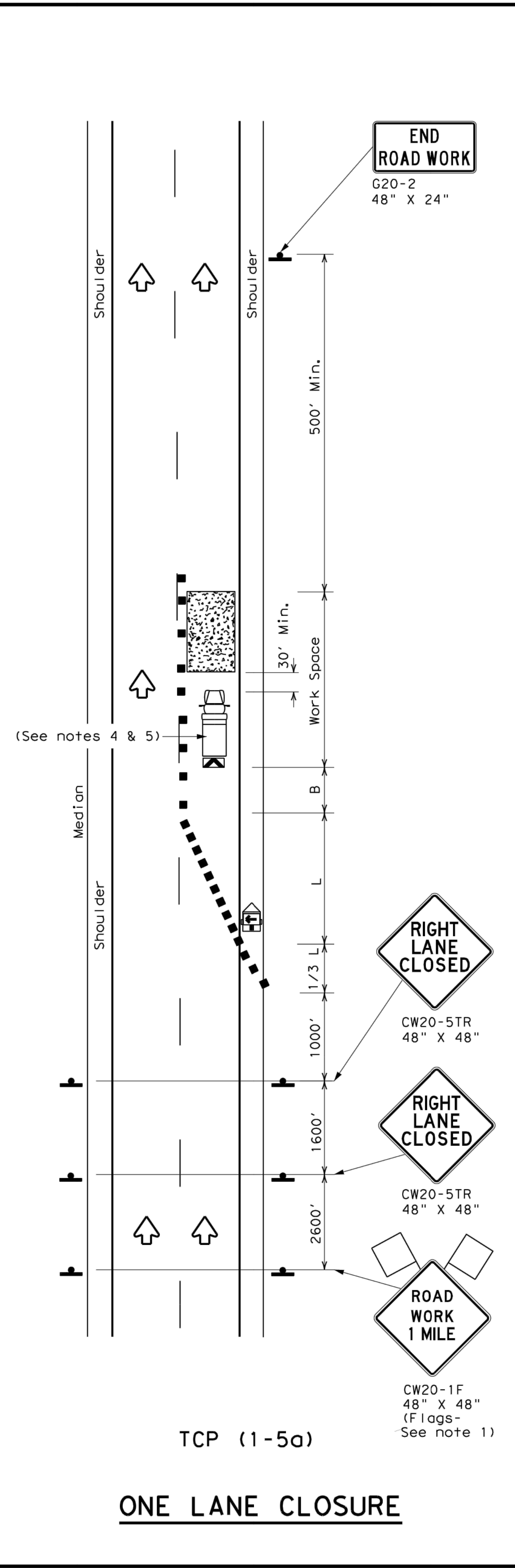

TCP (1-5a) ONE LANE CLOSURE

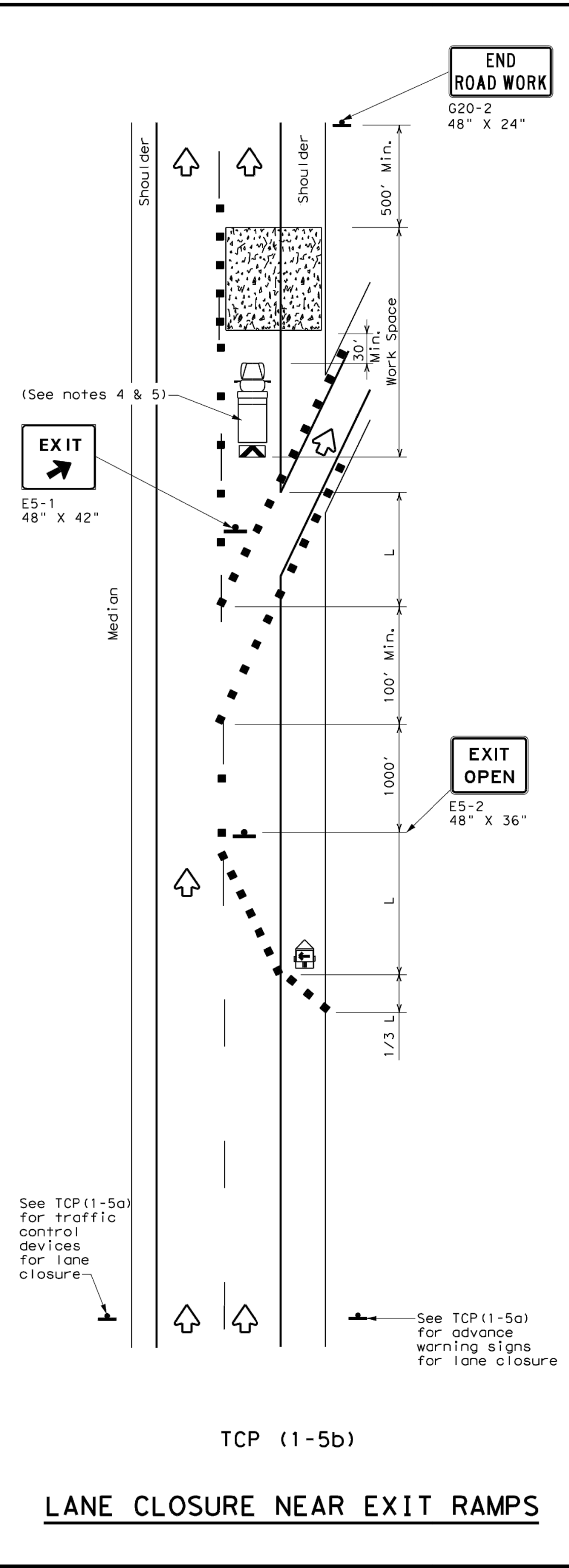

TCP (1-5b) LANE CLOSURE NEAR EXIT RAMP

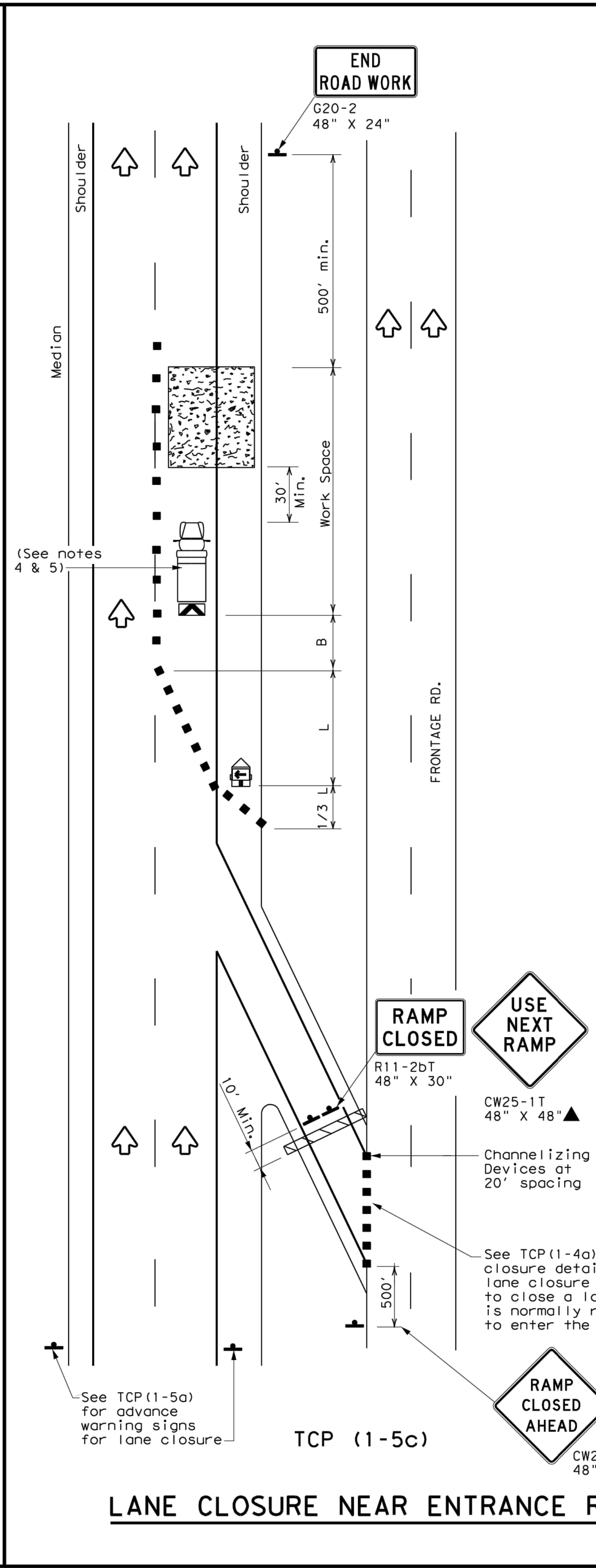

TCP (1-5c) LANE CLOSURE NEAR ENTRANCE RAMP

LEGEND			
	Type 3 Barricade		Channelizing Devices
	Heavy Work Vehicle		Truck Mounted Attenuator (TMA)
	Trailer Mounted Flashing Arrow Board		Portable Changeable Message Sign (PCMS)
	Sign		Traffic Flow
	Flag		Flagger

Posted Speed *	Formula	Minimum Desirable Taper Lengths **			Suggested Maximum Spacing of Channelizing Devices		Minimum Sign Spacing "X" Distance	Suggested Longitudinal Buffer Space "B"
		10' Offset	11' Offset	12' Offset	On a Taper	On a Tangent		
30	$L = \frac{WS^2}{60}$	150'	165'	180'	30'	60'	120'	90'
35		205'	225'	245'	35'	70'	160'	120'
40		265'	295'	320'	40'	80'	240'	155'
45	L = WS	450'	495'	540'	45'	90'	320'	195'
50		500'	550'	600'	50'	100'	400'	240'
55		550'	605'	660'	55'	110'	500'	295'
60		600'	660'	720'	60'	120'	600'	350'
65		650'	715'	780'	65'	130'	700'	410'
70		700'	770'	840'	70'	140'	800'	475'
75		750'	825'	900'	75'	150'	900'	540'

* Conventional Roads Only
 ** Taper lengths have been rounded off.
 L = Length of Taper (FT) W = Width of Offset (FT) S = Posted Speed (MPH)

TYPICAL USAGE				
MOBILE	SHORT DURATION	SHORT TERM STATIONARY	INTERMEDIATE TERM STATIONARY	LONG TERM STATIONARY
		✓		

- GENERAL NOTES**
- Flags attached to signs where shown, are REQUIRED.
 - All traffic control devices illustrated are REQUIRED, except those denoted with the triangle symbol may be omitted when stated elsewhere in the plans, or for routine maintenance work, when approved by the Engineer.
 - Channelizing devices used to close lanes may be supplemented with the Chevron Alignment Sign placed on every other channelizing device. Chevrons may be attached to plastic drums as per BC Standards.
 - Shadow Vehicle with TMA and high intensity rotating, flashing, oscillating or strobe lights. A Shadow Vehicle with a TMA should be used anytime it can be positioned 30 to 100 feet in advance of the area of crew exposure without adversely affecting the performance or quality of the work. If workers are no longer present but road or work conditions require the traffic control to remain in place, Type 3 Barricades or other channelizing devices may be substituted for the Shadow Vehicle and TMA.
 - Additional Shadow Vehicles with TMAs may be positioned in each closed lane, on the shoulder or off the paved surface, next to those shown in order to protect a wider work space.



**TRAFFIC CONTROL PLAN
LANE CLOSURES FOR
DIVIDED HIGHWAYS**

TCP (1-5) - 18

FILE: tcp1-5-18.dgn	DN:	CK:	DW:	CK:
© TxDOT February 2012	CONT	SECT	JOB	HIGHWAY
2-18	REVISIONS		DIST	COUNTY
				SHEET NO.

BORDER RELEASE DATE: October 16, 2021
 01/20/2021 10:09:09 AM
 C:\Users\TFC\Documents\HOK\DAL\DFW\Int'l Airport - CTR Expansion Program\Project Files\01_CTR - Terminal C Garages and Roadways\02_DFW-TC-TCP-18-011-MOTDetails.dwg



2330 N INTERNATIONAL PARKWAY
DFW AIRPORT, TX 75261

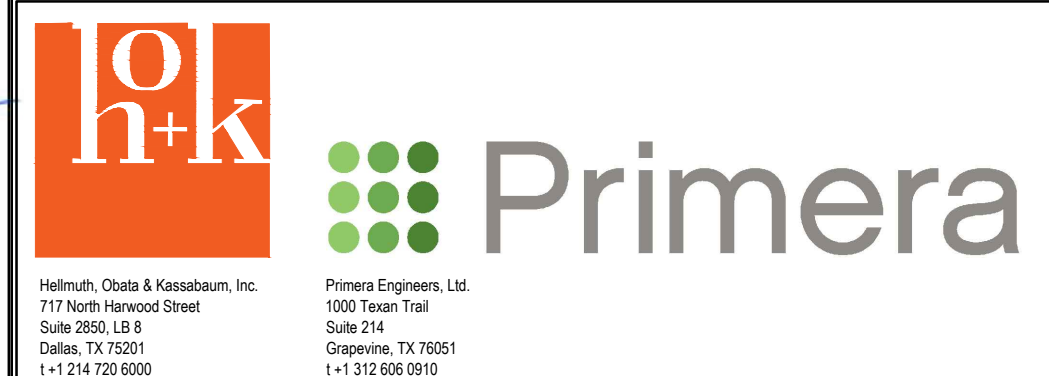
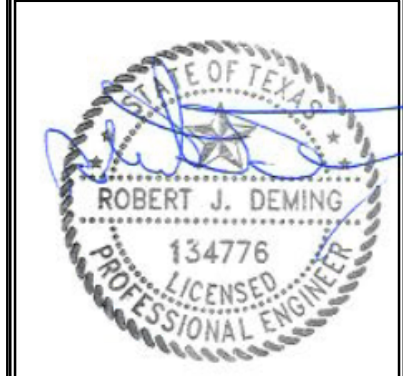

DRAWN BY: JMR
 APPROVED BY: RJD
 ISSUE DATE: 2022-07-28
NOT FOR BID OR CONSTRUCTION

NO.	DATE	DESCRIPTION
2022-07-28	100% DESIGN	
2022-07-28	100% DESIGN FOR PERMIT (DPP)	

TERMINAL C GARAGE & ROADWAYS
MOT DETAILS

PROJECT NUMBER: TFD-007

SHEET NUMBER
CT123-900R

PERMIT NUMBER: B22-0023

SCALE(S) AS NOTED ON THIS SHEET ARE BASED ON A FULL SIZE 30 X 42 SHEET.

EXISTING LEGEND

- TELECOM MANHOLE A
- TELECOM MANHOLE B
- TELECOM DUCT BANK
- ELECTRIC MANHOLE
- ELECTRIC DUCT BANK
- SANITARY SEWER MANHOLE
- SANITARY SEWER PIPE
- SANITARY SEWER CLEANOUT
- STORM TRENCH DRAIN
- STORM CATCH BASIN
- STORM GRATE INLET
- STORM MANHOLE (TYPE A)
- STORM MANHOLE (TYPE B)
- STORM MANHOLE (TYPE C)
- STORM MANHOLE (TYPE D)
- IRRIGATION CONTROL VALVE
- STORM PIPE
- WATER VALVE
- FIRE HYDRANT
- CATHODIC PROTECTION
- WATER PIPE
- SIGN
- TREE
- BUSH
- LIGHT POLE
- ELECTRIC PULLBOX
- NATURAL GAS

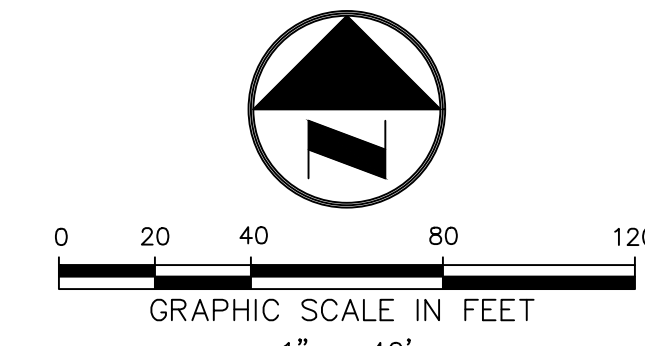

DEMOLITION LEGEND

- X X X EXISTING PIPE TO BE REMOVED
- /// EXISTING PIPE TO BE REPLACED VIA TRENCHLESS REPLACEMENT

- NOTES:**
- EXISTING UNDERGROUND UTILITIES ARE SHOWN PER EXISTING RECORD DRAWINGS AND SUBSURFACE UTILITY ENGINEERING. AT-GRADE APPURTENANCES WERE SURVEYED IN THE FIELD.
 - EXISTING PIPES TO BE REMOVED, AS NOTED IN THE LEGEND, SHALL INCLUDE ALL CATHODIC PROTECTION TEST STATIONS, VALVES, FITTINGS, THRUST BLOCK, AND FIRE HYDRANTS.

COORDINATE!!

- CONTACT:**
- DIG-TESS 1-800-DIG-TESS
 - ATMOS ENERGY 1-800-332-8667
 - ONCOR ELECTRIC 972-888-1359
 - AT&T 1-817-588-1056
 - CHARTER SPECTRUM 1-817-205-8177
 - TXU 1-800-711-9112
 - TEXAS ONE CALL 811
 - 48 HOURS PRIOR TO CONSTRUCTION

DEMOLITION GENERAL NOTES

- CONTRACTOR IS TO REVIEW ALL GENERAL NOTES PRIOR TO BEGINNING WORK.
- REMOVE ALL EXISTING PAVEMENT AND STRUCTURES WITHIN THE LIMITS OF DEMOLITION UNLESS OTHERWISE NOTED.
- SAWCUT AND REMOVE ALL EXISTING DRIVE APPROACHES (WITHIN THE LIMITS OF DEMOLITION) TWO FEET FROM BACK OF CURB. SIDEWALKS, PAVEMENT, AND UTILITIES WITHIN THE PUBLIC RIGHT-OF-WAY ARE TO REMAIN UNLESS OTHERWISE NOTED.
- CONSULT THE DIMENSIONAL CONTROL PLAN. VERIFY THE PORTION OF EXISTING CONCRETE CURBS AND PAVEMENT WHICH ARE TO REMAIN.
- COORDINATE WITH LOCAL POWER, TELEPHONE, CABLE, AND GAS COMPANIES PRIOR TO THE REMOVAL AND/OR RELOCATION OF EXISTING UTILITIES.
- ALL UTILITIES SHOULD BE CUT AND PLUGGED IN ACCORDANCE WITH THEIR RESPECTIVE UTILITY COMPANY REQUIREMENTS AND PRIOR TO DEMOLITION OF THE EXISTING BUILDINGS.
- CONTRACTOR TO PLUG ALL EXISTING EXPOSED ENDS OF ABANDONED UTILITIES.
- CONTRACTOR TO DETERMINE SOURCE OF ALL EXPOSED UTILITIES AND, IF REQUIRED, RECONNECT TO PROPOSED UTILITIES.
- CONTRACTOR IS RESPONSIBLE FOR THE REMOVAL AND LEGAL DISPOSAL OF ALL THE UNSUITABLE MATERIALS FROM THE PROJECT SITE. CONTRACTOR SHALL CONTACT ALL LOCAL AUTHORITIES TO DETERMINE DISPOSAL REQUIREMENTS.
- ALL TREES ON THE PROPERTY SHALL BE PROTECTED AGAINST DAMAGE DURING DEMOLITION OPERATIONS UNLESS OTHERWISE NOTED. THE TREE PROTECTION SHALL BE PLACED AROUND TREES PRIOR TO ANY DEMOLITION OR GRADING. TREE PROTECTION SHALL REMAIN UNTIL ALL WORK IS COMPLETED. REFER TO LANDSCAPE PLANS FOR TREE REMOVAL AND PROTECTION DETAILS.
- ANY DAMAGE DONE TO EXISTING TREE CROWNS OR ROOT SYSTEMS SHALL BE REPAIRED IMMEDIATELY BY AN APPROVED TREE SURGEON AT THE OWNER'S DIRECTION. ROOTS EXPOSED AND/OR DAMAGED DURING DEMOLITION AND/OR GRADING OPERATIONS SHALL BE CUT OFF CLEANLY INSIDE THE EXPOSED OR DAMAGED AREA, CUT SURFACES PAINTED WITH AN APPROVED TREE PAINT, AND TOPSOIL AND MULCH PLACED OVER THE EXPOSED ROOT AREA IMMEDIATELY.
- CONTRACTOR IS RESPONSIBLE FOR ESTABLISHING AND MAINTAINING EROSION CONTROL MEASURES ON THE SITE IN ACCORDANCE WITH FEDERAL, STATE, AND LOCAL REGULATIONS UNTIL THE SIGHT HAS BEEN STABILIZED.
- CONTRACTOR IS RESPONSIBLE FOR GRADING ALL DISTURBED AREAS TO ALLOW FOR POSITIVE DRAINAGE. GRADING SLOPES ARE NOT TO EXCEED 3:1.
- AREAS EXCAVATED FOR FOUNDATION OR UNDERGROUND STRUCTURE REMOVAL SHALL BE BACK FILLED AND COMPACTED TO A MINIMUM OF 95% STANDARD PROCTOR DENSITY.
- CONTRACTOR IS RESPONSIBLE FOR SECURITY OF THE SITE DURING DEMOLITION ACTIVITIES AND UNTIL SUBSTANTIAL COMPLETION.
- ALL WORK, UNLESS OTHERWISE NOTED, SHALL CONFORM TO THE STANDARD SPECIFICATIONS FOR PUBLIC WORKS CONSTRUCTION ISSUED BY THE NORTH CENTRAL TEXAS COUNCIL OF GOVERNMENTS AND DFW AIRPORT STANDARD CONSTRUCTION SPECIFICATIONS.
- THE HORIZONTAL AND VERTICAL LOCATIONS OF EXISTING SUBSURFACE UTILITIES HAVE BEEN DETERMINED FROM DATA RECORDED BY OTHERS. IT WILL BE THE RESPONSIBILITY OF THE CONTRACTOR TO PROTECT ALL UTILITY MAINS, MANHOLES, CLEANOUTS, VALVE BOXES, AND FIRE HYDRANTS, ETC. IN THE AREA OF DEMOLITION.
- THE CONTRACTOR IS RESPONSIBLE FOR COMPLIANCE WITH ALL FEDERAL, STATE, AND LOCAL REGULATIONS REGARDING TRENCH SAFETY.
- BARRICADING AND PROJECT SIGNS SHALL CONFORM TO TEXAS DEPARTMENT OF TRANSPORTATION MANUAL ON UNIFORM TRAFFIC CONTROL DEVICES AND LATEST UPDATES.
- CONTRACTOR SHALL MAINTAIN EXISTING PAVEMENT AND ACCESS TO FIRE HYDRANTS ON SITE UNTIL THE BUILDINGS AND STRUCTURES IN THAT AREA HAVE BEEN DEMOLISHED AND REMOVED.
- CONTRACTOR WILL PROVIDE ON-SITE PARKING FOR WORKERS. VEHICLE PARKING WILL NOT BE ALLOWED WITHIN THE PUBLIC RIGHT-OF-WAY.
- CONTRACTOR WILL BE RESPONSIBLE FOR IMPLEMENTING AND MAINTAINING ADEQUATE DUST CONTROL MEASURES DURING DEMOLITION ACTIVITIES.
- CONTRACTOR IS TO COORDINATE DEMOLITION ACTIVITIES WITH THE HAZARDOUS MATERIAL ABATEMENT CONTRACTORS' ACTIVITIES, IF APPLICABLE.
- THE CONTRACTOR WILL BE RESPONSIBLE FOR OBTAINING ALL TEMPORARY UTILITY SERVICES REQUIRED TO COMPLETE THE SCOPE OF WORK.
- WHERE POSSIBLE ABANDONED WATER MAINS SHALL BE REMOVED. WATER MAINS SHALL BE ABANDONED BY CUTTING AND PLUGGING WHERE IT IS NOT POSSIBLE TO REMOVE THE EXISTING PIPE. THE CUT AND PLUG SHALL BE AS CLOSE TO THE MAIN LEFT IN SERVICE AS PRACTICAL UNLESS THERE IS OTHER PENDING UTILITY WORK PLANNED THAT COULD DISTURB THE PLUG. IF THE NEW MAIN IS TO BE CONSTRUCTED TO CONNECT TO THE EXISTING MAIN AT THE POINT OF CUT, A CUT AND PLUG IS NOT REQUIRED. IF THE MAIN IS TO BE ABANDONED AT A TAP AND VALVE, THE ABANDONED TAPPING SLEEVE AND VALVE SHALL BE REMOVED.
- REMOVED/SALVAGED FIRE HYDRANTS SHALL BE HANDED OVER TO DFW UTILITIES GROUP.
- VALVE SMALLER THAN 16 INCHES ARE NOT TO BE SALVAGED. UPON REMOVAL OF THE VALVE COVER, STACK, AND STEM EXTENSION, THE VALVE BODY MUST BE ABANDONED BY FILLING WITH 2 SACKS PER CUBIC YARD MIX OF SAND TO A POINT AT LEAST 12 INCHES BELOW THE PAVEMENT. VALVES 16 INCHES AND LARGER MAY BE SALVAGED IF REQUIRED BY DFW.
- CONTRACTOR TO COORDINATE TIMING OF DEMOLITION OF THE FIRE HYDRANTS AND WATER LINES SERVING THE HYDRANTS WITH THE OFFICE OF THE FIRE MARSHALL.
- FIRE APPARATUS ACCESS ROADS SHALL BE MAINTAINED DURING CONSTRUCTION.
- ALL WATER LINE VALVES WILL NEED TO BE REMOVED AND A BLIND FLANGE OR CAP AT MAIN.

KEY PLAN

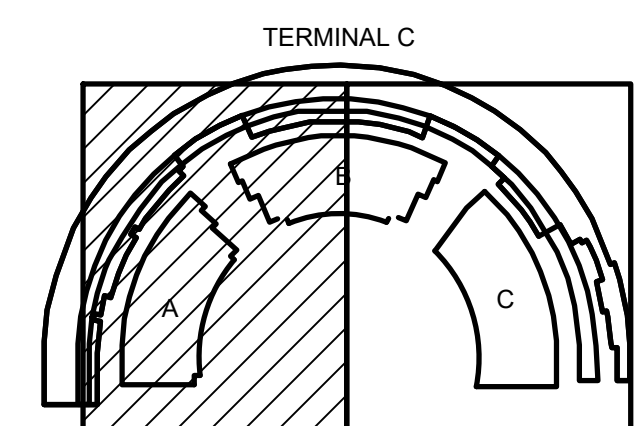

MULTI-STORY CONCRETE PARKING GARAGE A

MULTI-STORY CONCRETE PARKING GARAGE B

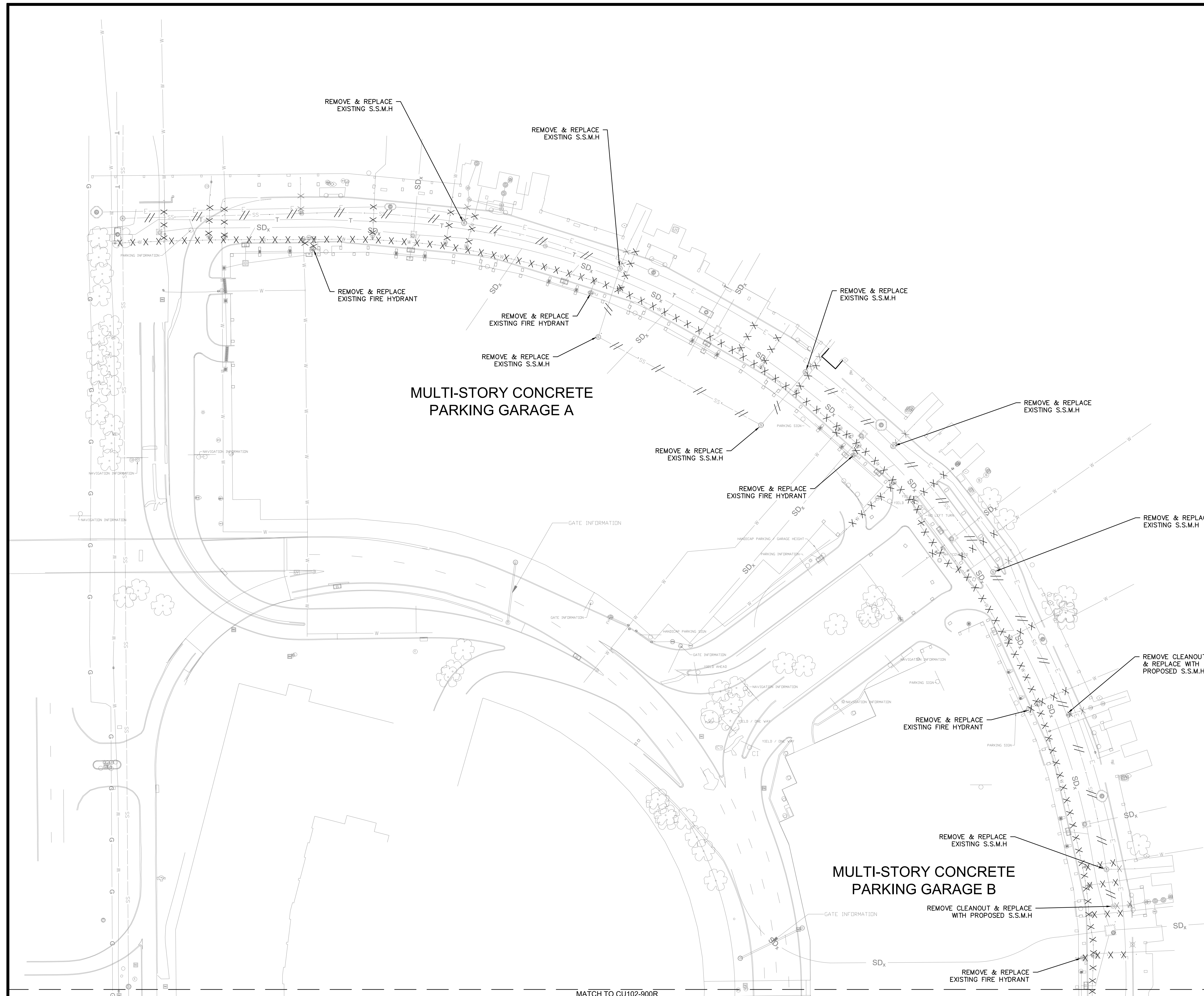

BORDER RELEASE DATE: October 16, 2021
 01/02/2021 7:46:09 AM
 C:\Users\jgallagher\Documents\DWG\DFW\Terminal C Expansion Program\Project Files\01 CTA - Terminal C Garage and Roadways\CE01 - CTA\Sheet\080302.DWG\TC-CU101-0100_Demo.dwg



DALLAS
 FORT WORTH
 INTERNATIONAL
 AIRPORT

 2330 N INTERNATIONAL PARKWAY
 DFW AIRPORT, TX 75261



DRAWN BY: KWF
 APPROVED BY: PJW
 ISSUE DATE: 2022-07-28
NOT FOR BID OR CONSTRUCTION

NO.	DATE	DESCRIPTION
0001-00-00	07/28/2022	30% DESIGN
0002-01-00	07/28/2022	30% DESIGN
0003-02-00	07/28/2022	100% DESIGN
0004-03-00	07/28/2022	100% DESIGN FOR PERMIT (PDP)

PROJECT NUMBER: TFD-007
 TERMINAL C GARAGE & ROADWAYS
UTILITY DEMOLITION PLAN 1
 SHEET NUMBER
CU101-900R
 PERMIT NUMBER: A21-188B
 SCALE(S) AS NOTED ON THIS SHEET ARE BASED ON A FULL SIZE 30 X 42 SHEET

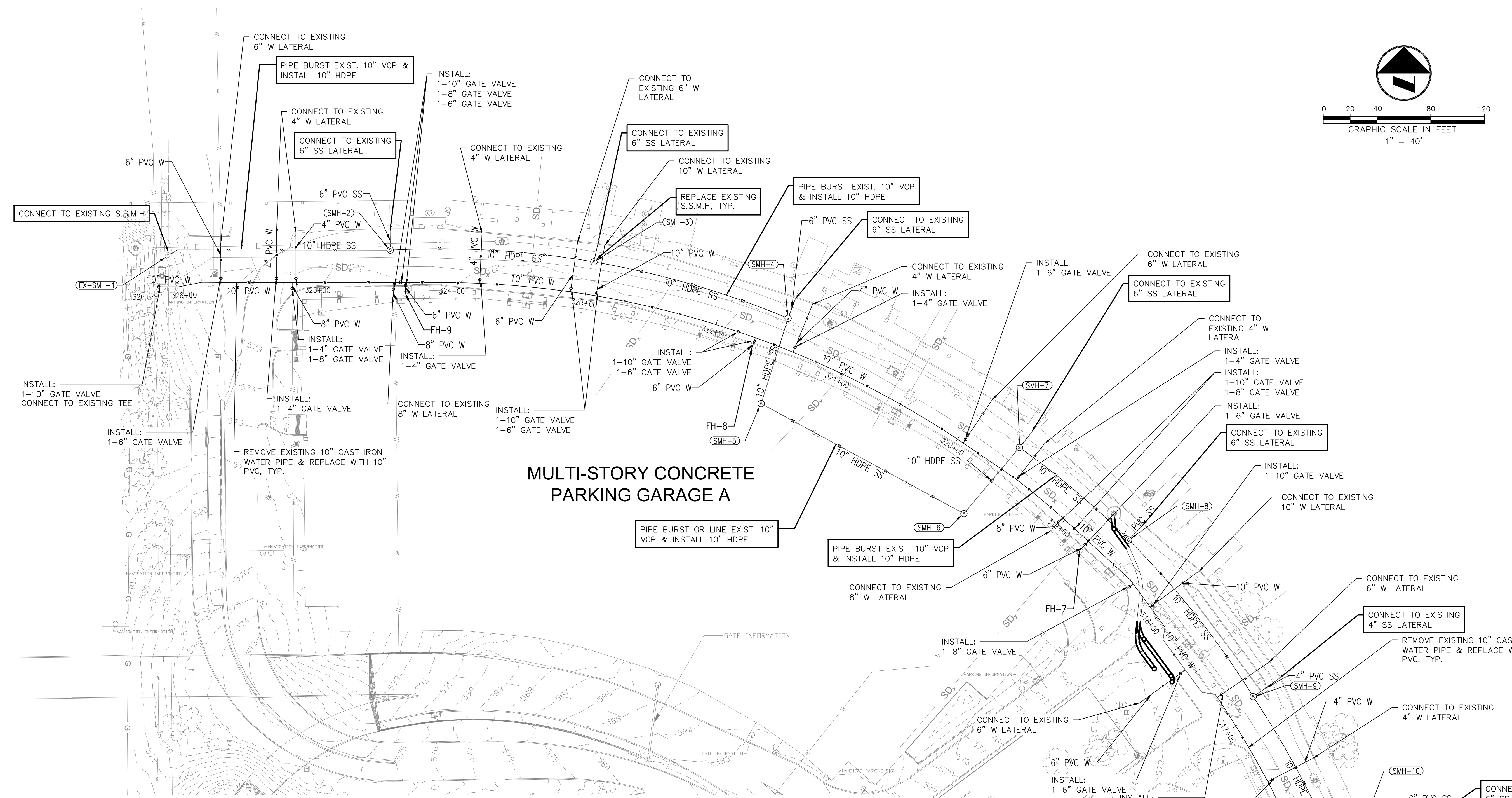

EXISTING LEGEND

TELECOM MANHOLE A	IRRIGATION CONTROL VALVE
TELECOM MANHOLE B	STORM PIPE
TELECOM DUCT BANK	WATER VALVE
ELECTRIC MANHOLE	FIRE HYDRANT
ELECTRIC DUCT BANK	CATHODIC PROTECTION WATER PIPE
SANITARY SEWER MANHOLE	SIGN
SANITARY SEWER PIPE	TREE
SANITARY SEWER CLEANOUT	BUSH
STORM TRENCH DRAIN	LIGHT POLE
STORM CATCH BASIN	ELECTRIC PULLBOX
STORM GRATE INLET	NATURAL GAS
STORM MANHOLE (TYPE A)	
STORM MANHOLE (TYPE B)	
STORM MANHOLE (TYPE C)	
STORM MANHOLE (TYPE D)	

COORDINATE!!

CONTACT:
 DIG-TESS 1-800-DIG-TESS
 ATMOS ENERGY 1-800-332-8667
 ONCOR ELECTRIC 972-886-1359
 AT&T 1-817-588-1056
 CHARTER SPECTRUM 1-817-205-8177
 TXU 1-800-711-9112
 TEXAS ONE CALL 1-800-711-9112
 48 HOURS PRIOR TO CONSTRUCTION

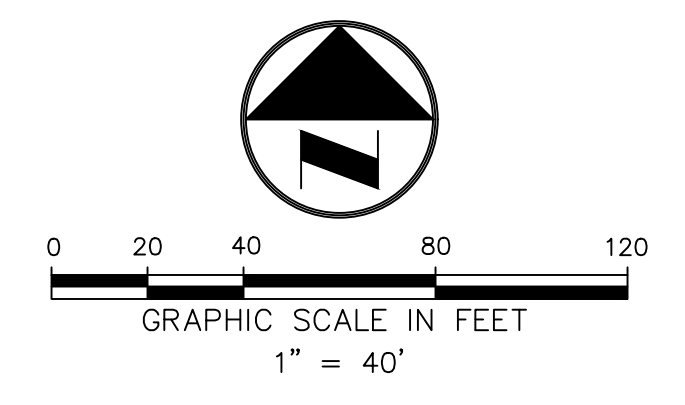

MULTI-STORY CONCRETE PARKING GARAGE A

WATER & SANITARY SEWER GENERAL NOTES (1/2)

- ALL CONCRETE SHALL BE CLASS "A" (3000 PSI), UNLESS OTHERWISE NOTED.
- ALL WATER MAINS SHALL BE PVC C900, DR 14, CLASS 305, AND BLUE IN COLOR. FIRE PROTECTION SERVICES SHALL BE PVC C900, DR 14, CLASS 305 AND INSTALLED IN ACCORDANCE WITH THE DESIGN AND SPECIFICATION OF THE FIRE PROTECTION PLANS TO BE PREPARED BY A LICENSED FIRE PROTECTION CONTRACTOR.
- WATER AND SANITARY SEWER SERVICES SHALL MEET PLUMBING CODE REQUIREMENTS.
- ALL WATER MAINS SHALL HAVE A MINIMUM COVER OF 72 INCHES BELOW IMPROVED FINISHED GRADE, UNLESS OTHERWISE NOTED.
- SANITARY SEWER PIPE SHALL BE AWWA C900 DR25, GREEN IN COLOR, AND BE PER DFW DESIGN CRITERIA MANUAL REVISIONS 2 STANDARDS.
- AWWA C900, C905, OR P303 RCP IS REQUIRED FOR ALL PRESSURIZED APPLICATIONS. ALL PRESSURIZED PIPE SHALL BE INSTALLED WITHIN CASINGS UNDER ROADWAYS, TAXIWAYS, AND RUNWAYS. ENCASMENT PIPE SHALL BE USED TO ENCASE THE CARRIER PIPE. CARRIER PIPE SHALL HAVE RESTRAINED JOINTS BY INTERNAL RESTRAINTS SYSTEM. THE CROSSING SHOULD BE PERPENDICULAR TO THE ROADWAY, RUNWAY AND TAXIWAYS ALIGNMENT BASED ON EXISTING CONDITIONS. ENCASMENT PIPE FOR ROADWAY CROSSING SHALL BE MINIMUM OF TEN (10) FEET AWAY FROM EDGE OF PAVEMENT.
- WHEN WATER AND SANITARY SEWER MAINS, SERVICES, AND LATERALS ARE INSTALLED, THEY SHALL BE INSTALLED NO CLOSER TO EACH OTHER THAN NINE FEET IN ALL DIRECTIONS AND PARALLEL LINES MUST BE INSTALLED IN SEPARATE TRENCHES. WHERE THE NINE FOOT SEPARATION DISTANCE CANNOT BE ACHIEVED, THE FOLLOWING TRENCH CHARTERS SHALL APPLY.
- TRENCH CHARTER 217.53 PIPE DESIGN, SECTION (d) SEPARATION DISTANCES.
- TRENCH CHARTER 290.44 WATER DISTRIBUTION, SECTION (e) LOCATION OF WATER LINES.
- CONTRACTOR TO VERIFY ALL EXISTING SEWER FLOW LINES BEFORE BEGINNING CONSTRUCTION.
- ALL SANITARY SEWER LINES SHALL BE TESTED IN ACCORDANCE WITH THE DFW DESIGN CRITERIA MANUAL REVISION 2.
- TRENCH BACKFILL MATERIAL SHALL CONFORM TO THE REQUIREMENTS OF NCTCOG ITEM 504.2 AND SHALL BE MECHANICALLY COMPACTED IN 6-INCH LIFTS TO THE TOP OF SUBGRADE TO A MINIMUM OF 95% STANDARD PROCTOR DENSITY IN ACCORDANCE WITH NCTCOG ITEM 504.5 UNLESS OTHERWISE SHOWN ON THESE PLANS.
- EMBEDMENT SHALL CONFORM TO THE REQUIREMENTS OF NCTCOG ITEM 504.5 UNLESS OTHERWISE SHOWN IN THESE PLANS.
- VALVE BOXES SHALL BE FURNISHED AND SET ON EACH GATE VALVE. AFTER THE FINAL CLEAN-UP AND ALIGNMENT HAS BEEN COMPLETED, THE UTILITY CONTRACTOR SHALL POUR A 24"x24"x26" CONCRETE BOX AROUND ALL VALVE BOX TOPS LEVEL WITH THE FINISHED GRADE.
- CONTRACTOR SHALL RECONNECT ALL EXISTING SERVICE AND MAINTAIN EXISTING SERVICES THROUGHOUT CONSTRUCTION.
- IF REQUIRED DUE TO CONSTRUCTION, POWER POLES TO BE BRACED OR RELOCATED AT CONTRACTOR'S EXPENSE.
- WATER PIPE SHALL BE BLUE, SANITARY SEWER PIPE SHALL BE GREEN, AND RECLAIMED WATER PIPE SHALL BE PURPLE. ALL PIPES SHALL BE PLACED WITH DETECTOR WIRE OVER THE PIPE, AND A UTILITY MARKING TAPE PLACED ONE FOOT ABOVE THE PIPE. THE COLOR OF THE TAPE SHALL MATCH THE COLOR OF THE PIPE MATERIAL AND SHALL IDENTIFY THE SPECIFIC UTILITY.
- IT IS RECOMMENDED THAT A CEMENTITIOUS FILL MATERIAL BE CONSIDERED AS A BACKFILL MATERIAL FOR ALL TRENCHES OCCURRING UNDER ANY ROADWAY, TAXIWAY, SHOULDER OR PARKING LOT.
- AFTER TRENCH HAS BEEN CUT TO A DEPTH BELOW THE BARREL OF THE PIPE A DISTANCE OF 3 INCHES, THE BEDDING SHALL BE BROUGHT TO A POINT SLIGHTLY ABOVE GRADE WITH COMPACTED SAND. BELL HOLES SHALL BE FORMED, IF REQUIRED, A TROUGH SCOOPED OUT TO GRADE AND THE PIPE LAID AND JOINTED AS SPECIFIED. THE SAND SHALL THEN BE BROUGHT UP IN UNIFORM LAYERS OF EITHER SIDE OF THE PIPE AND OVER THE PIPE TO A POINT 12 INCHES ABOVE THE TOP OF THE PIPE. BEDDING MATERIAL SHALL BE CHART OR CUSHION SAND.
- STRUCTURES DESIGNED FOR MANUFACTURING OR THE POSSIBLE FUTURE USE WHERE MANUFACTURING MAY OCCUR SHALL HAVE A SAMPLING POINT INSTALLED IN THE SEWER LINE, OUTSIDE THE BUILDING PRIOR TO THE CONNECTION TO ANY SANITARY SEWER MAIN.
- A COLLECTION SYSTEM PIPE ENTERING A MANHOLE MORE THAN 24" ABOVE INVERT MUST HAVE A DROP PIPE. INVERT DROPS FOR MANHOLES SHALL BE WITHIN 24" OF INVERTS.
- TRENCH REQUIREMENTS WATER CROSSING UNDER SANITARY SEWER TO BE ENCASED. WHEN A NEW WATER LINE CROSSES A WASTEWATER MAIN OR LATERAL, THE WATER LINE SHALL BE ENCASED OR CONSTRUCTED OF DUCTILE IRON OR STEEL PIPE WITH MECHANICAL OR WELDED JOINTS AS APPROPRIATE. AN ABSOLUTE MINIMUM SEPARATION DISTANCE OF ONE FOOT BETWEEN THE AFTER LINE AND THE WASTEWATER MAIN OR LATERAL SHALL BE PROVIDED.
- WHERE CEMENT STABILIZED SAND BEDDING IS REQUIRED, THE CEMENT STABILIZED SAND SHALL HAVE A MINIMUM OF 10% CEMENT PER CUBIC YARD OF CEMENT STABILIZED SAND MIXTURE, BASED ON LOOSE DRY WEIGHT VOLUME (AT LEAST 2.5 BAGS OF CEMENT PER CUBIC YARD OF MIXTURE). THE CEMENT STABILIZED SAND BEDDING SHALL BE A MINIMUM OF SIX INCHES ABOVE AND FOUR INCHES BELOW THE WASTEWATER MAIN OR LATERAL. THE USE OF BROWN COLORING IN CEMENT STABILIZED SAND FOR WASTEWATER MAIN OR LATERAL BEDDING IS RECOMMENDED FOR THE IDENTIFICATION OF PRESSURE RATED WASTEWATER MAINS DURING FUTURE CONSTRUCTION.
- CLEANOUTS SHALL BE PLACED ON WASTEWATER LATERALS EVERY 100 FEET.
- MANHOLES NEED TO HAVE AT LEAST A 30" MANHOLE RING AND COVER.
- MANHOLES THAT ARE NOT IN ROADWAYS WILL NEED A SQUARE CONCRETE PAD AROUND THE RING AND COVER.
- ALL SANITARY SEWER LINES MUST BE INSPECTED, CLEANED WITH A VIDEO SYSTEM, AND REVIEWED BY CONTRACTOR BEFORE A COPY OF THE RESULTS ARE SENT TO DESIGN, CODE AND CONSTRUCTION FOR APPROVAL.
- THE INVERTS OR SANITARY SEWER MANHOLES SHALL BE REWORKED AND GROUTED TO FORM A SMOOTH FLOW TRANSITION FROM NEW PIPE TO EXISTING.

- ALL SANITARY SEWER CLEANOUTS AND MANHOLES SHALL BE MARKED IN GREEN ON CURBS.
- THIRTY DAYS PRIOR TO TEMPORARY CERTIFICATE OF OCCUPANCY IS ISSUED AND PRIOR TO TESTING, ALL SANITARY SEWER LINES MUST BE INSPECTED BY A THIRD PARTY, WITH A VIDEO SYSTEM AND A COPY OF THE TAPS SUBMITTED TO AIRPORT DEVELOPMENT UTILITIES, DESIGN, CODE, AND CONSTRUCTION (DCO) FOR APPROVAL. AFTER APPROVAL OF THE TAP, ALL INSTALLED SANITARY SEWER PIPE MUST BE TESTED SO THAT THE COMPLETE SYSTEM WILL HAVE A ZERO EXFILTRATION LOSS PER 2 HOURS, WHERE THE HYDROSTATIC HEAD AT THE DESIGN HYDRAULIC GRADE LINE IS NO LESS THAN 4 FEET OF TEST STACK WITH THE HEIGHT OF THE TEST STACK MATCHING THE HIGHEST ELEVATIONS OF THE SANITARY SEWER PIPE. A PNEUMATIC TEST AT 3 PSI MAY BE SUBSTITUTED FOR THE HYDROSTATIC TEST TO SUBSTANTIATE THE EXFILTRATION CRITERIA. THE AIR PRESSURE SHALL BE EQUIVALENT TO THE COMPARABLE HYDROSTATIC TEST PRESSURES.
- MANHOLES MUST BE VACUUM TESTED WITH A NEGATIVE PRESSURE OF 3 PSI, MAINTAINING A ZERO PRESSURE DROP FOR 5 MINUTES.
- AFTER THE TRENCH HAS BEEN CUT TO A DEPTH BELOW THE BARREL OF THE PIPE OF 6 INCHES, THE BEDDING SHALL BE BROUGHT TO A POINT SLIGHTLY ABOVE GRADE WITH COMPACT MATERIAL. THE BEDDING MATERIAL SHALL THEN BE BROUGHT UP IN UNIFORM LAYERS ON EITHER SIDE OF THE PIPE AND OVER THE PIPE TO A POINT 12 INCHES ABOVE THE TOP OF PIPE. BEDDING MATERIAL SHALL BE CHART OR CUSHION SAND.
- ALL PVC AND DUCTILE IRON PIPE SHALL USE FULL BODY DUCTILE IRON FITTINGS. COMPACT FITTINGS ARE NOT ALLOWED. ALL 90 DEGREE BENDS SHALL BE AVOIDED IN THE SYSTEM, IF POSSIBLE.
- MAINS ARE TO BE INSTALLED AS STRAIGHT AS POSSIBLE, BUT EXCESS DEPTHS SHALL BE AVOIDED.
- TAPPING SLEEVES AND VALVE SHALL BE USED WHENEVER POSSIBLE TO CONNECTIONS TO EXISTING MAINS TO AVOID INTERRUPTIONS TO WATER SERVICES. TAPS ARE RESTRICTED TO AT LEAST ONE STANDARD PIPE SIZE SMALLER THAN THE TAPPED PIPE. FULL BODY TAPPING SLEEVES SHALL BE USED. A TAPPING SLEEVE WILL NOT BE ALLOWED IF THE MATERIALS AND CONDITIONS OF THE EXISTING MAIN PRECLUDE TAPPING. SIDE-ON-SIZE TAPS WILL NOT BE PERMITTED. TAPPING SHALL BE MADE BY USE OF AN APPROVED FULL BODIED MECHANICAL JOINT TAPPING SLEEVE. FOR ALL RCP WATER MAINS, TAPPING SLEEVES ARE NOT PERMITTED.
- CONNECTIONS 4" AND LARGER OF NEW MAINS TO EXISTING MAINS SHALL BE MADE BY CUTTING IN A TEE. TAPPING SLEEVES MAY BE ALLOWED IN LIEU OF CUTTING IN A TEE ON A CASE-BY-CASE BASIS.
- ALL PRESSURIZED PIPE SHALL BE INSTALLED WITHIN CASINGS UNDER ROADWAYS, TAXIWAYS, AND RUNWAYS. CASING PIPE SHALL BE REINFORCED CONCRETE CYLINDER PIPE (RCCP) OR PVC (SCHEDULE 80 OR AWWA C900). STEEL CASING PIPE CAN BE USED EXCEPT THAT STEEL HAS TO BE CATHOLICALLY PROTECTED. CORRUGATED STEEL PIPE SHALL NOT BE USED AS CASING PIPE. ALL PIPE INSTALLED WITHIN A SLEEVE WILL REQUIRE RAC-SPACES ON A FOOT CENTER.
- A NEW VALVE SHALL BE INSTALLED AT THE POINT OF CONSTRUCTION FOR WATER MAIN EXTENSIONS TO FACILITATE TESTING AND CHARACTERIZATION OF THE NEW MAIN PRIOR TO ITS PLACEMENT INTO SERVICE.
- PERMANENT DOMESTIC WATER SERVICES SHALL NOT BE SUPPLIED FROM FIRE HYDRANT LINES. DOMESTIC WATER SERVICES MAY TAP INTO FIRE LOOP OR LEAD IN, PROVIDED THAT DOMESTIC TAP IS LOCATED PRIOR TO THE BACKFLOW PREVENTER, WHICH IS LOCATED AT LEASE BOUNDARY/ROW.
- TYPICAL SMALL WATER SERVICES RANGE FROM 1 INCH THOUGH 2 INCHES IN DIAMETER. WATER SERVICES OVER 30 FEET SHALL BE A MINIMUM OF 1 INCH DIAMETER. TYPICALLY, AWWA C901 POLY-PIPE WITH FLOOR COUPLINGS AND FITTINGS SHALL BE USED FOR SMALL WATER SERVICE.
- ALL TEMPORARY CONSTRUCTION WATER SERVICES SHALL BE PROVIDED WITH LINE SIZED BACKFLOW PREVENTER DOUBLE CHECK VALVE ASSEMBLY AND WATER METER. SERVICES SHALL NOT BE INSTALLED UNTIL BACKFLOW PREVENTION DEVICES HAVE BEEN TESTED AND APPROVED FOR OPERATION BY A TCEQ CERTIFIED TESTER. ALL ORIGINAL TEST FORMS SHALL BE RETURNED TO THE ENGINEERING DEPARTMENT, P.O. BOX 612008, DFW AIRPORT, TX 75261-2008.
- WHERE THE SERVICE LINE PROVIDES POTABLE WATER FOR A DOMESTIC SERVICE AND ALSO CONNECTS WITH OTHER CLOSED OR CHEMICALLY TREATED SYSTEMS THAT COULD FORESEEABLY CONTAMINATE THE POTABLE WATER LINE, A BACKFLOW PREVENTER SHALL BE INSTALLED. DRAINS OFF THE BACKFLOW PREVENTER ASSEMBLY SHALL BE DRAINED TO THE SANITARY SEWER. TAPS TO MAINS, TO PROVIDE WATER FOR FIRE PROTECTION OF OTHER CLOSED SYSTEMS, SHALL HAVE A DOUBLE CHECK VALVE ASSEMBLY AT THE FIRE LINE TAP. AN ALTERNATE METHOD OF BACKFLOW PREVENTION CONSISTING OF A 1/2 INCH AIR GAP BETWEEN AN UNRESTRICTED OVERFLOW OF AN ATMOSPHERIC MAKEUP TANK AND THE SOURCE OF WATER IS ALSO ACCEPTABLE. ALL DOUBLE CHECK AND REDUCED PRESSURE SERVICE SHALL BE PROVIDED WITH 2-INCH SQUARE NUT OPERATOR AND SHALL BE INSTALLED WITH EXTENSION STEMS WHERE REQUIRED TO EXTEND OPERATING NUT WITHIN 12 INCHES OF THE FINISHED GRADE.
- ALL PRESSURE REDUCING BACKFLOW PREVENTERS THAT ARE INSTALLED TO PROTECT HIGH-HAZARD SERVICES FROM BACK-FLOWING MUST BE TESTED ANNUALLY FROM THE DATE THEY ARE INSTALLED TO THE FINISHED GROUND LINE IN PAVED AREAS OR SLIGHTLY ABOVE GRADE IN OTHER AREAS. TOPS SHALL BE COMPLETE WITH COVERS AND SHALL BE ADJUSTABLE. VALVE STACKS SHALL BE SET VERTICAL AND CONCENTRIC WITH THE VALVE STEM. A CONCRETE PAD SHALL BE POURED AROUND ALL VALVE STACKS WHEN NOT IN PAVED AREAS. ALL GATE VALVES SHALL BE NON-RISING STEM UNLESS OTHERWISE INDICATED AND SHALL TURN COUNTERCLOCKWISE TO OPEN. VALVES SHALL BE PROVIDED WITH A HAND-WHEEL OPERATOR UNLESS OTHERWISE DESIGNATED. VALVES OR CORPORATION STOPS FOR BURIED SERVICE SHALL BE PROVIDED WITH 2-INCH SQUARE NUT OPERATOR AND SHALL BE INSTALLED WITH EXTENSION STEMS WHERE REQUIRED TO EXTEND OPERATING NUT WITHIN 12 INCHES OF THE FINISHED GRADE.
- ALL FIRE HYDRANTS SHALL BE ISOLATED FROM THE MAIN WATER AND FROM OTHER WATER SERVICES BY INSTALLATION OF A GATE VALVE BETWEEN THE MAIN WATER LINE AND THE FIRE HYDRANT IN ORDER TO FACILITATE REPAIR OF THE FIRE HYDRANT WITHOUT HAVING TO SHUT OFF THE MAIN WATER LINE. FIRE HYDRANTS SHOULD BE PAINTED FIRE ENGINE RED. FIRE HYDRANT WILL BE 5 FEET BURIED. WHEN NECESSARY DUE TO CONFLICTS, AN EXTENSION OF 1 FOOT MAY BE USED. A MINIMUM OF 7 CUBIC FEET OF WASHED PEA GRAVEL SHALL BE LAID AROUND THE WEEP HOLES OF THE FIRE HYDRANT.

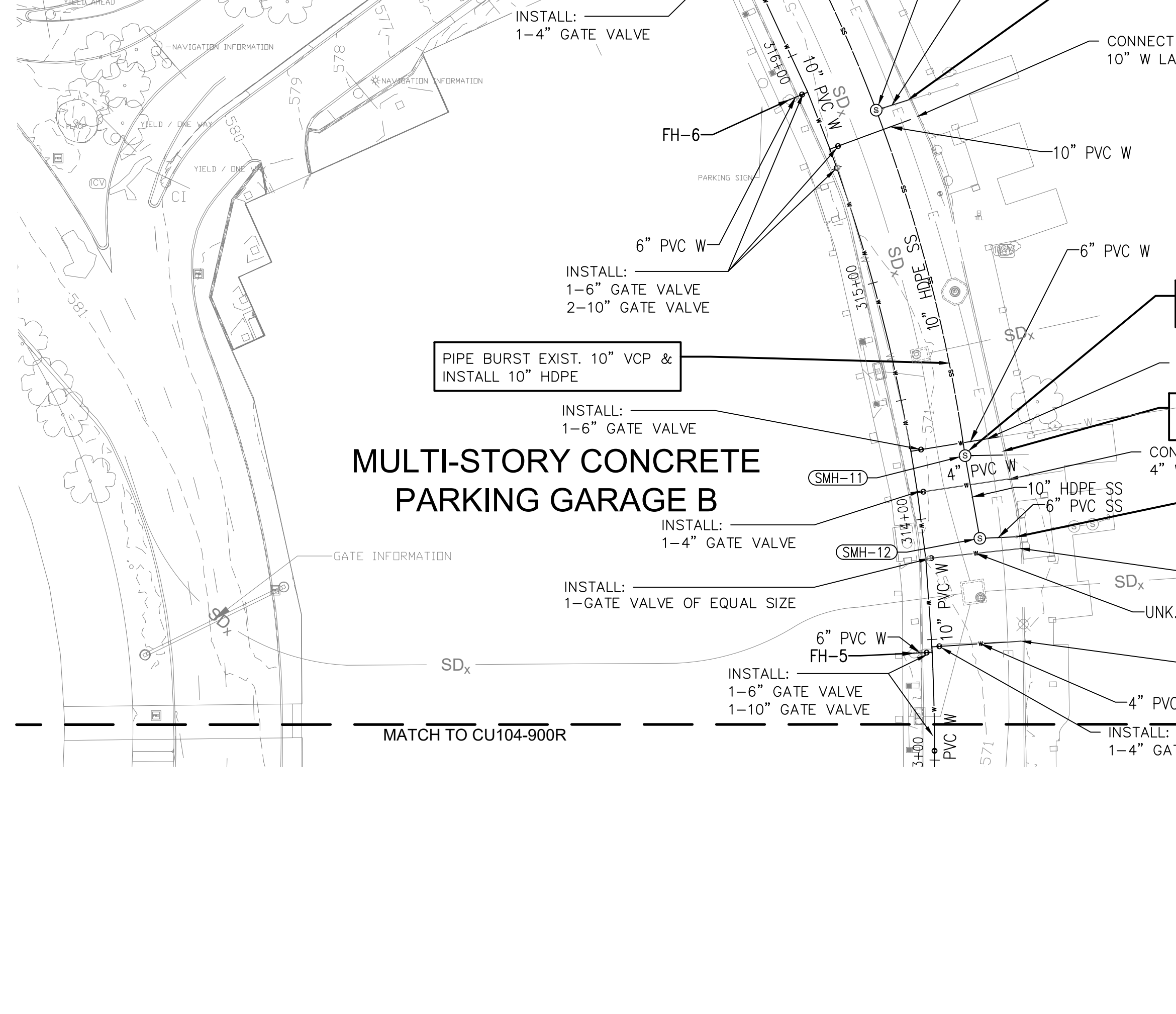

- ### NOTES:
- EXISTING UNDERGROUND UTILITIES ARE SHOWN PER EXISTING RECORD DRAWINGS AND SUBSURFACE UTILITY ENGINEERING. AT-GRADE APPURTENANCES WERE SURVEYED IN THE FIELD.
 - FOR THE CONSTRUCTION OF THE PROPOSED 10" WATER, CONTRACTOR SHALL INSTALL A TEMPORARY 10" WATER ABOVE GRADE TO MAINTAIN SERVICE AT ALL TIMES DURING CONSTRUCTION.
 - FOR THE CONSTRUCTION OF THE SANITARY SEWER, CONTRACTOR SHALL PIPE BURST ALONG THE MAIN WITH HDPE. CONTRACTOR TO UTILIZE BYPASS PUMPING TO MAINTAIN SERVICE AT ALL TIMES DURING CONSTRUCTION.
 - ANY WATER AND SANITARY SEWER LATERAL SHALL USE CONVENTIONAL TRENCHING WITH PVC WATER PIPE. CONTRACTOR TO COORDINATE WITH AIRPORT TO AND IN REGARDS TO SHUTTING OFF WATER VALVES.
 - CONTRACTOR TO PERFORM CCTV VIDEO OF ALL SANITARY SEWER THAT IS TO BE REPLACED.

PROPOSED UTILITIES LEGEND

10" PVC W	WATER LINE
10" PVC SS	SANITARY SEWER LINE VIA TRENCHING
10" HDPE SS	SANITARY SEWER LINE VIA PIPE BURSTING
⊙	SANITARY SEWER MANHOLE
⊕	FIRE HYDRANT
+	WATER TEE

WATER & SANITARY SEWER GENERAL NOTES (2/2)

- BEFORE AND NEWLY CONSTRUCTED WATER MAIN WILL BE PERMITTED TO BE PLACED INTO SERVICE IN THE POTABLE WATER SUPPLY, IT SHALL BE FLUSHED OR PURGED, STERILIZED AND TESTED TO ASSURE COMPLIANCE WITH TCEQ STANDARDS. DFW WATER DEPARTMENT WILL TAKE A WATER SAMPLE AFTER THE WATER LINE HAS BEEN PRESSURE TESTED AND FLUSHED. WATER SAMPLES ARE CONDUCTED MONDAY THROUGH THURSDAY AND RESULTS WILL BE AVAILABLE 24 HOURS LATER. FLUSHING PROVISIONS SHALL BE MADE TO FLUSH THE PIPE WITH POTABLE WATER UNTIL ALL DIRT, SLUDGE, AND DEBRIS ARE REMOVED. IF FLUSHING IS UNSUCCESSFUL, THE PIPE MUST BE PURGED. NO FLUSHING WATER CAN BE DISCHARGED DIRECTLY INTO A STORM DRAIN. FLUSH WATER MUST PASS THROUGH AN ESTABLISHED BEST MANAGEMENT PRACTICE DEVICE.
- PERFORM HYDROSTATIC PRESSURE AND LEAKAGE TEST USING METHODS PER PERFORMANCE REQUIREMENTS OF AWWA C-600. THE PRESSURE REQUIRED FOR HYDROSTATIC PRESSURE TEST SHALL BE A MINIMUM 100 PSI WITH 0% LEAKAGE FOR 2 HOURS.
- STERILIZATION OF THE MAIN SHALL BE ACCOMPLISHED BY INJECTING CALCIUM HYPOCHLORITE INTO ONE END OF THE LINE UNTIL WATER RELEASED FROM THE OTHER END INDICATES A CHLORINE RESIDUAL OF 50 PARTS PER MILLION. ALL VALVES SHALL THEN BE CLOSED, AND THE SOLUTION SHALL BE ALLOWED TO DISINFECT THE PIPE FOR AT LEAST 24 HOURS. PROVISIONS SHALL BE MADE FOR DISPOSING ALL CHLORINATED WATER INTO THE SANITARY SEWER SYSTEM DIRECTLY AFTER THE COMPLETION OF THE STERILIZATION PROCESS. NO DISCHARGING OR STERILIZATION WATER DIRECTLY TO STORM SEWER SYSTEM.
- ABANDONED WATER MAINS SHALL BE REMOVED. IF THE MAIN IS TO BE ABANDONED AT A TAP AND VALVE, THE ABANDONED SLEEVE AND VALVE SHALL BE REMOVED.
- REMOVED/SALVAGED FIRE HYDRANTS SHALL BE HANDED OVER TO DFW UTILITIES GROUP.
- VALVES SMALLER THAN 16 INCHES ARE NOT TO BE SALVAGED. UPON REMOVAL OF THE VALVE COVER, STACK, AND STEM EXTENSION, THE VALVE BODY MUST BE ABANDONED BY FILLING WITH 2 BAGS PER CUBIC YARD MIX OF SAND TO A POINT AT LEAST 12 INCHES BELOW THE PAVEMENT. VALVES 16 INCHES AND LARGER MAY BE SALVAGED IF REQUESTED BY DFW.
- ALL METAL PIPING AND FITTINGS SHALL BE PROTECTED BY A CATHODIC PROTECTION SYSTEM THAT IS DESIGNED BY A NACE CERTIFIED PROFESSIONAL AND INSTALLED BY A LICENSED CONTRACTOR.
- PVC PIPE SHALL BE USED FOR ALL MAINS 16-INCH AND SMALLER.
- ALL RCP SHALL BE USED WITH REQUIRED DIELECTRIC COATINGS, AS NECESSARY.
- EXTERNAL AND INTERNAL PROTECTIVE COATING SHALL BE CONSIDERED FOR ALL METALLIC PIPES AS NECESSARY TO LIMIT THE RATE OF CATHODIC REACTION.
- ISOLATING JOINTS BY USING INSULATING KITS OF OTHER MEANS ARE REQUIRED TO PREVENT GALVANIC CORROSION FOR ALL METALLIC PIPES IN THE FOLLOWING LOCATIONS: CHANGES IN PIPELINE MATERIALS, CONNECTIONS TO EXISTING PIPING, INLET AND OUTLET PIPING OF PLANT FACILITIES, LATERALS FROM TRANSMISSION MAINS, TAPS TO EXISTING RCP, VALVE TO RCP, METALLIC CASING SPACER TO RCP.
- WATER METERS SHALL BE REQUIRED AT ALL SERVICE POINTS AND SHALL CONFORM TO THE FOLLOWING: WATER METERS SHALL BE BOTH A VISUAL ODOMETER AND IN AN ELECTRIC MEMORY. ALL NEW APPLICATIONS SHALL UTILIZE BADGER BEACON WITH HR-LED ENCODERS, LITE ENDOPOINTS. METERS UP TO 2 INCHES IN SIZE SHALL BE POSITIVE DISPLACEMENT TYPE METERS. THESE WATER METERS SHALL MEET OR EXCEED THE REQUIREMENTS OF AWWA C700 FOR COLD WATER METERS - DISPLACEMENT TYPE. METERS GREATER THAN 2 INCHES, AND ALL IRRIGATION METERS REGARDLESS OF SIZE, SHALL BE TURBINE TYPE. ALL TURBINE METERS SHALL HAVE A STRAINER. THESE WATER METERS SHALL MEET OR EXCEED AWWA C700 CLASS 2 STANDARDS. IF BOTH HIGH FLOW AND LOW FLOWS ARE ANTICIPATED, A COMPOUND TYPE METER SHALL BE USED. THESE METERS SHALL MEET OR EXCEED THE REQUIREMENTS OF AWWA C700 FOR COLD WATER METERS-COMPOUND TYPE.
- REGISTERS FOR ALL METERS SHALL READ IN STRAIGHT U.S. GALLONS.
- METERS WITH HR-LED AND PWT ELECTRONICS SHALL HAVE DATA PROFILING CAPABILITIES.
- METERS SHALL BE CONSTRUCTED OF COMPATIBLE METALS THROUGHOUT TO PREVENT ANY CORROSIIVE REACTION BETWEEN COMPONENT METALS.
- WHERE POSSIBLE, METERS AND METER BOXES SHALL BE LOCATED AT THE LEASE LINE.
- METER BOXES OR VALVETS SHALL BE SPECIFIED FOR EACH METER. PROVIDE CLAY DAM AND SEAL LEAK AT PIPE PENETRATIONS INTO VALVT.
- METER LOCATIONS SHALL BE IDENTIFIED ON THE PLANS AND SHALL BE OUTSIDE THE FACILITY SERVED AND AT A LOCATION THAT IS ACCESSIBLE TO UTILITY PERSONNEL AND SERVICE EQUIPMENT AT ALL TIMES.
- METER BOXES AND VALVETS SHALL HAVE CAST IRON OR STEEL DECK PLATE COVERS AS REQUIRED TO PROVIDE ADEQUATE SERVICE ACCESS TO THE TRANSMITTER SHALL HAVE AN OPENING FOR THE TRANSMITTER MOUNT, WHERE THE WEIGHT OF THE COVER OR COVER SECTIONS EXCEEDS 25 POUNDS, ALL METERS SHALL BE PROVIDED WITH SENSOR EXTENSION CABLE FOR MOUNTING THE SENSOR ON THE BOX OR VALVT, WHICH SHALL BE EASILY READABLE THROUGH A SMALL ACCESS DOOR IN THE COVER.
- A CONCRETE PAD SHALL BE PLACED AROUND ALL METER BOXES, EXTENDING 12 INCHES MINIMUM AROUND PERIMETER OF THE BOX. A 12 INCH THICK GRAVEL BED SHALL BE PLACED BELOW EACH METER BOX.
- METERS SHALL BE POSITIONED AT 18 INCHES BELOW THE TOP OF THE METER BOX.
- ALL MANHOLE FRAMES AND COVERS MUST MEET THE MINIMUM REQUIREMENTS AS SET IN 316 TAC 217.55, AND FOR MANHOLES LOCATED WITHIN THE AOA, ALL FAA REGULATIONS MUST BE MET. ALL MANHOLE FRAMES/COVERS, VALVE CASTING ARE STANDARD STEEL CASTINGS WITH A SPECIAL HEAVY-DUTY COVER. MANHOLE COVERS FOR POTABLE WATER MAINS SHALL BE 36 INCHES IN DIAMETER.
- VALVE BOXES FOR LIGHT TRAFFIC ARE THE STANDARD CONCRETE BOX WITH A SPECIAL COVER. VALVE BOXES FOR TRAFFIC AREAS ARE OF HEAVY-DUTY TRAFFIC DESIGN.

KEY PLAN

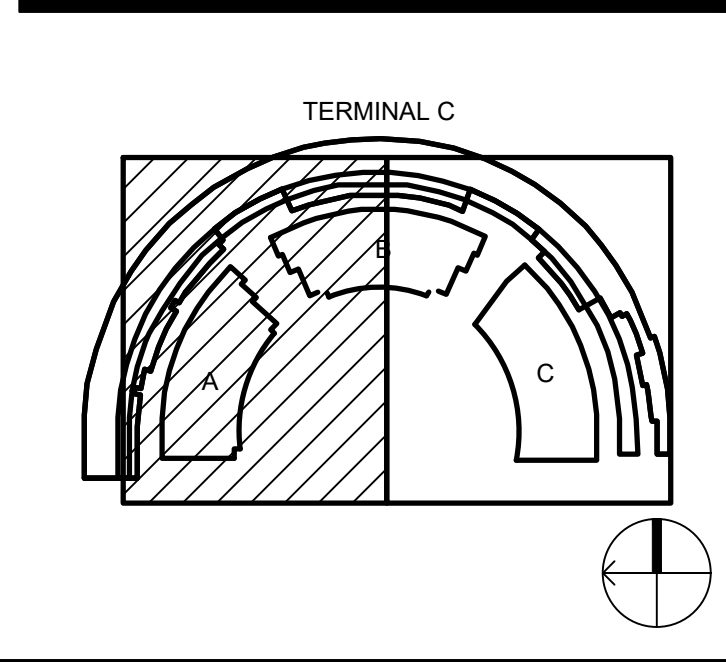

DALLAS FORT WORTH INTERNATIONAL AIRPORT

2330 N INTERNATIONAL PARKWAY
DFW AIRPORT, TX 75261

Patrick J. Williams
127408

hok

URBAN ENGINEERS

Urban Engineers, Inc. dba Urban Services, Inc.
777 South Greenville Avenue
Suite 200, L.B.
Dallas, TX 75201
972.752.9200
1-214-720-9900

NO.	DATE	DESCRIPTION
001	08/21/2023	30% DESIGN
002	09/21/2023	30% DESIGN
003	09/21/2023	100% DESIGN
004	09/21/2023	100% DESIGN FOR PERMIT (RFP)
005	09/21/2023	100% DESIGN FOR PERMIT (RFP)

DRAWN BY: KWF
 APPROVED BY: P.JW
 ISSUE DATE: 2022-07-28

NOT FOR BID OR CONSTRUCTION

PROJECT NUMBER: TFD-007

TERMINAL C GARAGE & ROADWAYS
 SITE UTILITY PLAN 1

SHEET NUMBER
 CU103-900R

PERMIT NUMBER: A21-1888

SCALE(S) AS NOTED ON THIS SHEET ARE BASED ON A FULL SIZE 30 X 42 SHEET.

BORDER RELEASE DATE: October 16, 2021
 01/20/2021 7:46:09 AM
 C:\Users\jgallagher\OneDrive\Documents\HOK\DAL\DFW\Int Airport - CTA Expansion Programs\Project Files\01 CTA - Terminal C Garage and Roadways\0302-DFW-TC-CU103-900R_S11.rvt

BORDER RELEASE DATE: October 16, 2021
 01/20/2021 7:46:09 AM
 C:\Users\jgier\OneDrive\Documents\HOK\Dallas\DFW\Terminal C\Expansion\Program\Project Files\01 CTA - Terminal C Garages and Roadways\05 GE01 - CTA\Sheet\050202-DFW\TC-CU104-900R_S11.dwg

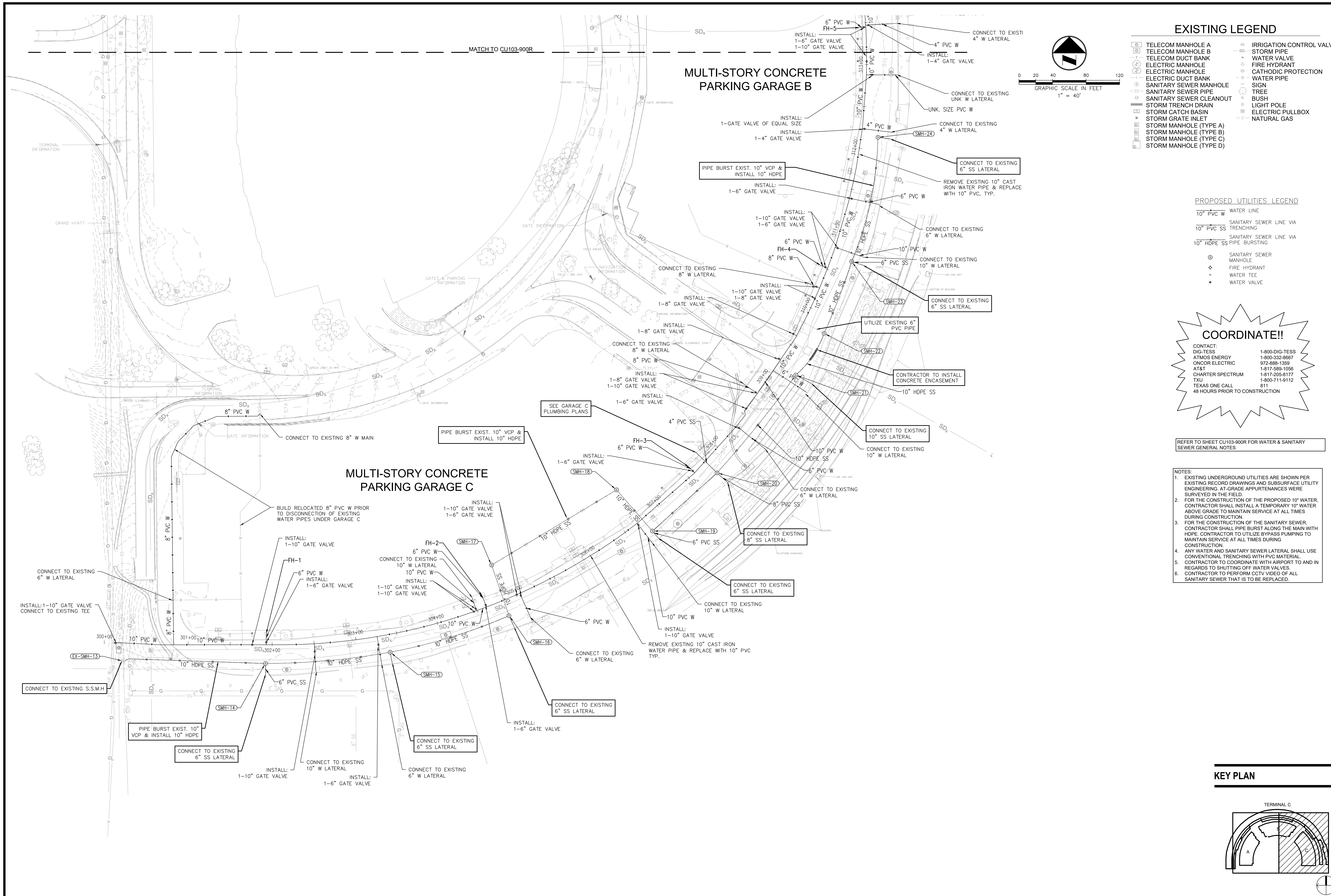

2330 N INTERNATIONAL PARKWAY
DFW AIRPORT, TX 75261



DRAWN BY: KWF
APPROVED BY: PJW
ISSUE DATE: 2022-07-28

NOT FOR BID OR CONSTRUCTION

NO.	DATE	DESCRIPTION
0001-01-01	3/24/2022	30% DESIGN
0002-01-01	05/21/2022	30% DESIGN
0003-01-01	06/29/2022	100% DESIGN
0004-01-01	08/02/2022	100% DESIGN FOR PERMIT (PDP)

TERMINAL C GARAGE & ROADWAYS
SITE UTILITY PLAN 2

PROJECT NUMBER: TFD-007

PERMIT NUMBER: A21-1888

SHEET NUMBER
CU104-900R

SCALE(S) AS NOTED ON THIS SHEET ARE BASED ON A FULL SIZE 30 X 42 SHEET.

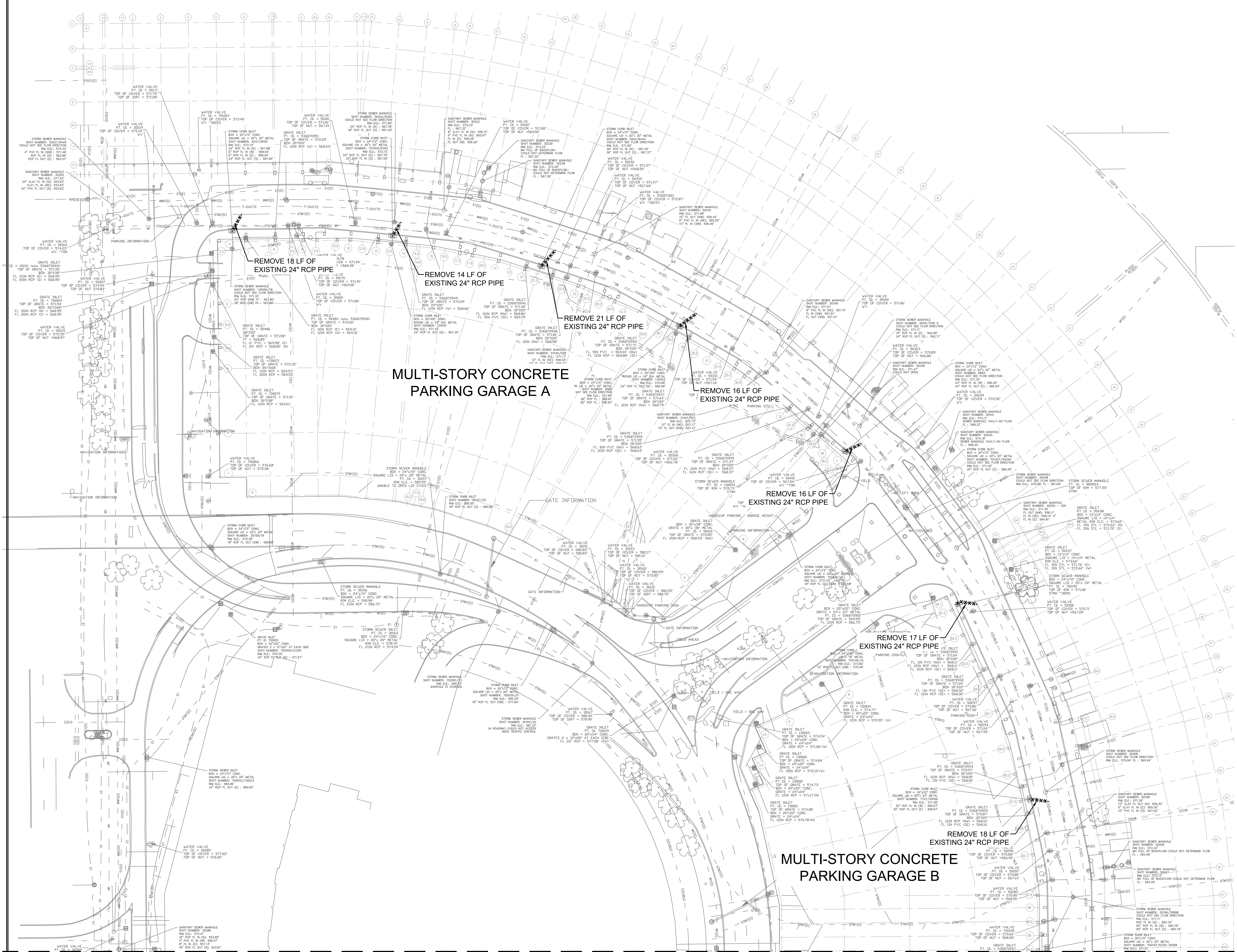
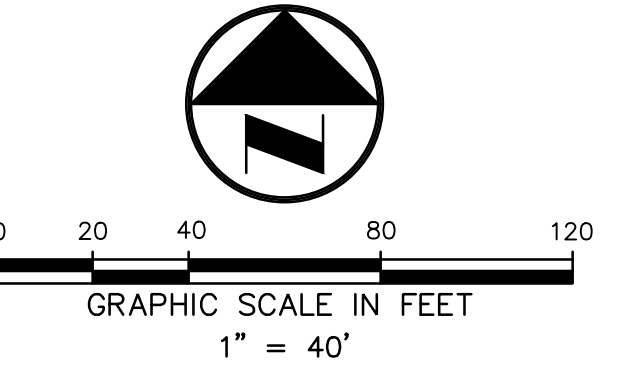

EXISTING LEGEND

- CRIADO CONTROL POINT
- IRON ROD FOUND
- BOLLARD
- GAS METER
- TRAFFIC SIGNAL LIGHT POLE
- TRAFFIC SIGNAL PULL BOX
- TRAFFIC SIGNAL CONTROL BOX
- TELECOM SERVICE BOX
- TELECOM PEDESTAL
- CATV PEDESTAL
- CATV JUNCTION BOX
- CATV APPURTENANCE
- LIGHT POLE
- CATHODIC PROTECTION FLAG POLE
- GENERIC MANHOLE
- POWER POLE
- GUYWIRE
- ELECTRIC MANHOLE
- ELECTRIC PULL BOX
- ELECTRIC METER
- ELECTRIC BOX
- ELECTRIC RISER
- GROUND LIGHT SIGN
- GAS PUMP
- FUEL TANK VENT TREE
- BUSH
- WASTE WATER CLEANOUT
- WASTE WATER MANHOLE
- STORM DRAIN MANHOLE
- WATER VALVE
- IRRIGATION CONTROL VALVE
- SPRINKLER HEAD
- SPIGOT
- FIRE HYDRANT
- WATER METER
- OVERHEAD UTILITY
- OVERHEAD ELECTRIC

DEMOLITION LEGEND

- EXISTING STORM SEWER TO BE REMOVED
- ////// EXISTING STORM SEWER TO BE FILLED AND ABANDONED

MATCHLINE - SEE SHEET CU106-900R

KEY PLAN

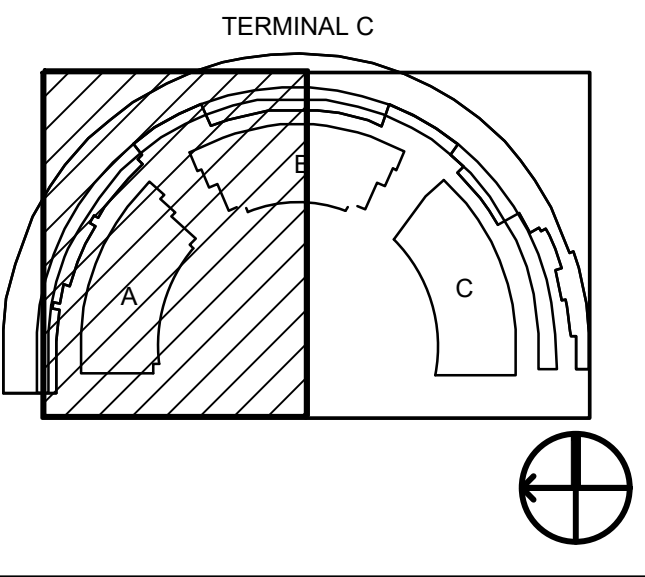

BORDER RELEASE DATE: October 16, 2021
01/20/2021 14:59:09
C:\Users\hrc22\OneDrive\Documents\DFW-TC-CU105-900R-Storm_Demo.dwg

DFW DALLAS FORT WORTH INTERNATIONAL AIRPORT
2330 N INTERNATIONAL PARKWAY
DFW AIRPORT, TX 75261

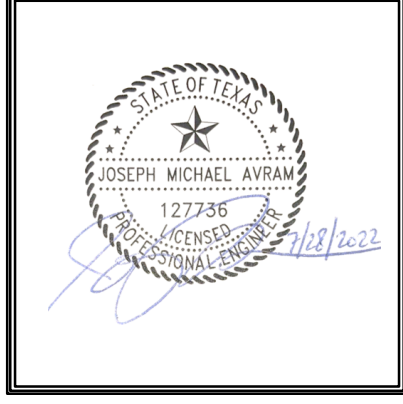

h+k Heitkamp, Chubb & Kasebaum, Inc.
777 North Meadows Drive
Suite 200, L.B.8
Dallas, TX 75201
+1 214 720 8000

Primera Primera Engineers, Ltd.
1300 Texas Tech
Suite 211
Cockeysville, TX 75011
+1 512 606 0110

DRAWN BY: PK
APPROVED BY: JMA
ISSUE DATE: 2022-07-28
NOT FOR BID OR CONSTRUCTION

NO.	DATE	DESCRIPTION
0001	01-20-20	37% DESIGN
0002	01-20-20	30% DESIGN
0003	02-01-20	100% DESIGN
0004	02-02-20	100% SUBMITTED FOR PERMIT (SP)

PROJECT NUMBER: TFD-007

TERMINAL C GARAGE & ROADWAYS
STORM SEWER DEMOLITION PLAN

PERMIT NUMBER: B22-0023

SCALE(S) AS NOTED ON THIS SHEET ARE BASED ON A FULL SIZE 30 X 42 SHEET.

SHEET NUMBER
CU105-900R

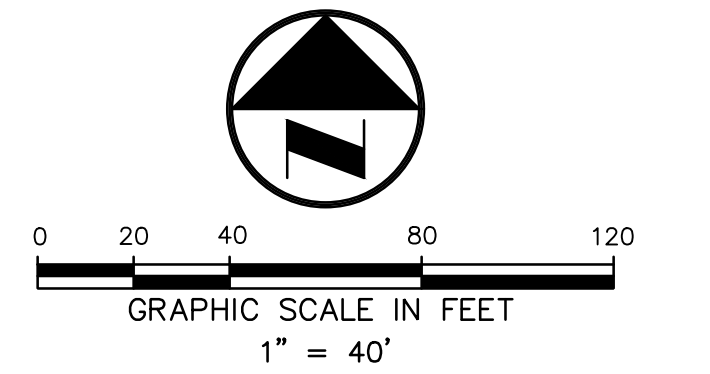

**MULTI-STORY CONCRETE
PARKING GARAGE B**

**MULTI-STORY CONCRETE
PARKING GARAGE C TO BE
DEMOLISHED**

EXISTING LEGEND

- CRIADO CONTROL POINT
- IRON ROD FOUND
- BOLLARD
- GAS METER
- TRAFFIC SIGNAL LIGHT POLE
- TRAFFIC SIGNAL PULL BOX
- TRAFFIC SIGNAL CONTROL BOX
- TELECOM SERVICE BOX
- TELECOM PEDESTAL
- CATV PEDESTAL
- CATV JUNCTION BOX
- CATV APPURTENANCE
- LIGHT POLE
- CATHODIC PROTECTION FLAG POLE
- GENERIC MANHOLE
- POWER POLE
- GUYWIRE
- ELECTRIC MANHOLE
- ELECTRIC PULL BOX
- ELECTRIC METER
- ELECTRIC BOX
- ELECTRIC RISER
- GROUND LIGHT SIGN
- GAS PUMP
- FUEL TANK VENT TREE
- BUSH
- WASTE WATER CLEANOUT
- WASTE WATER MANHOLE
- STORM DRAIN MANHOLE
- WATER VALVE
- IRRIGATION CONTROL VALVE
- SPRINKLER HEAD
- SPIGOT
- FIRE HYDRANT
- WATER METER
- OVERHEAD UTILITY
- OVERHEAD ELECTRIC

DEMOLITION LEGEND

- EXISTING STORM SEWER TO BE REMOVED
- ////// EXISTING STORM SEWER TO BE FILLED AND ABANDONED

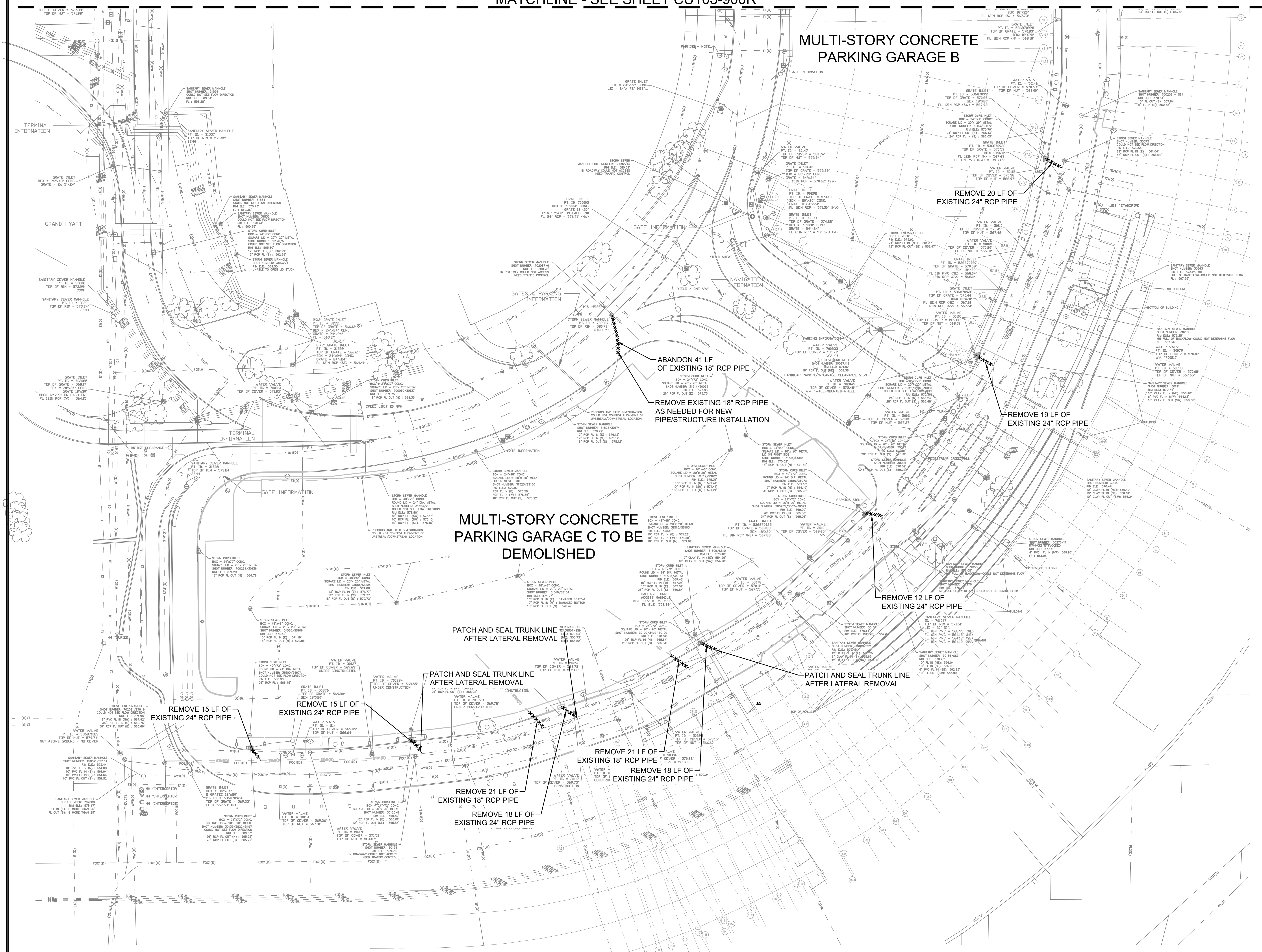

KEY PLAN

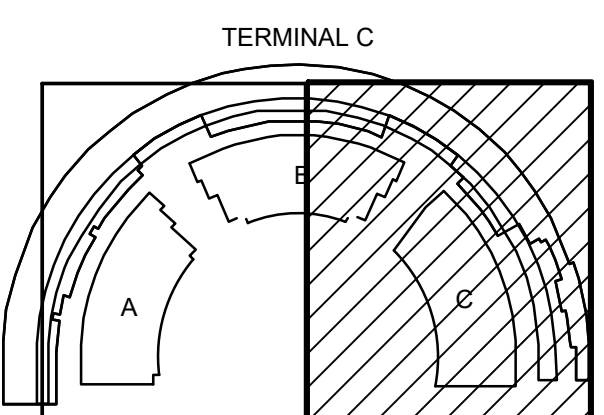

BORDER RELEASE DATE: October 16, 2021
01/20/2021 14:59:09
C:\Users\h32222\OneDrive\Documents\DFW-TC-CU106-900R-Storm-Demo.dwg



DALLAS
FORT WORTH
INTERNATIONAL
AIRPORT

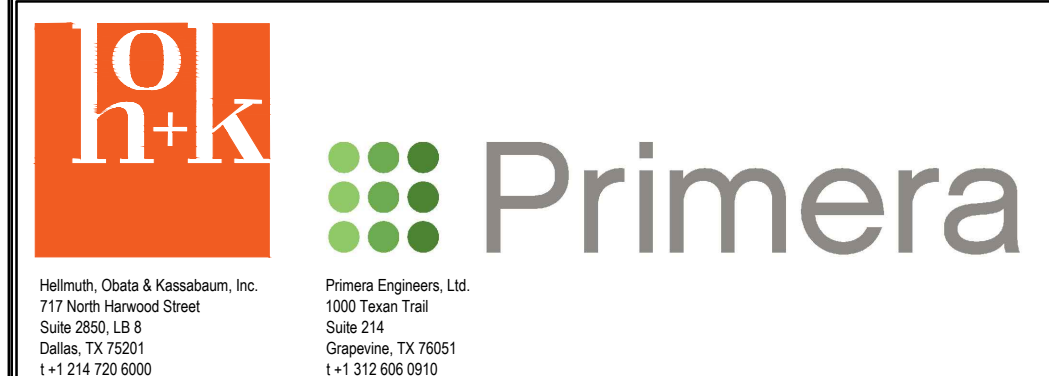
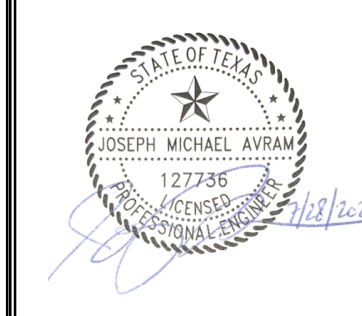

DRAWN BY: PK
APPROVED BY: JMA
ISSUE DATE: 2022-07-28
NOT FOR BID OR CONSTRUCTION

NO.	DATE	DESCRIPTION
001	2022-07-28	30% DESIGN
002	2022-01-09	30% DESIGN
003	2022-05-24	100% DESIGN
004	2022-07-28	100% SUBMITTAL FOR PERMIT (SFP)

PROJECT NUMBER: TFD-007

TERMINAL C GARAGE & ROADWAYS
STORM SEWER DEMOLITION PLAN

PERMIT NUMBER: B22-0023

SCALE(S) AS NOTED ON THIS SHEET ARE BASED ON A FULL SIZE 30 X 42 SHEET.

SHEET NUMBER
CU106-900R

MULTI-STORY CONCRETE PARKING GARAGE B

REPLACE ROADWAY DOWNSPOUTS PER DETAIL 2 ON SHEET CU503-900R. NO WORK TO BE PERFORMED ON TERMINAL DOWNSPOUTS ROUTED ON UNDERSIDE OF UPPER ROADWAY.

STORM STRUCTURE TABLE

NAME:	DETAILS:
CI-7748	CONNECT TO EXISTING INLET RIM: 570.79 INV OUT: 566.05 (24" RCP, W) INV OUT: 566.05 (24" RCP, SE)
CI-30109	CONNECT TO EXISTING INLET RIM: 570.04 INV IN: 565.64 (24" RCP, NW) INV OUT: 565.34 (24" RCP, SE)
CI-30125	CONNECT TO EXISTING INLET RIM: 569.86 INV IN: 565.08 (24" RCP, N) INV OUT: 565.06 (24" RCP, S)
CI-30135	CONNECT TO EXISTING INLET RIM: 569.63 INV IN: 565.20 (24" RCP, N) INV OUT: 565.22 (24" RCP, SE)
CI-31500	CURB INLET TYPE D RIM: 568.90 INV IN: 565.69 (12" RCP, NW) INV OUT: 565.22 (24" RCP, S)
CI-700255	CONNECT TO EXISTING INLET RIM: 569.99 INV IN: 565.33 (24" RCP, NW) INV OUT: 565.33 (24" RCP, E)
EX CURB INLET 190	CONNECT TO EXISTING INLET RIM: 573.47 INV OUT: 561.91 (12" RCP, NE)
EX CURB INLET 210	CURB INLET 3' X 6' RIM: 577.00 INV OUT: 563.75 (12" RCP, E)
EX CURB INLET 800	CONNECT TO EXISTING INLET RIM: 570.36 INV OUT: 565.58 (24" RCP, SE)
PR CURB INLET 300	CURB INLET RIM: 569.47 INV IN: 562.82 (18" RCP, NW) INV OUT: 560.82 (24" RCP, SE)
PR CURB INLET 400	TYPE D CURB INLET RIM: 569.65 INV OUT: 559.73 (15" RCP, SE)
PR GARAGE CURB INLET 1	TYPE D CURB INLET RIM: 569.65 INV OUT: 561.05 (12" RCP, SE)
PR GARAGE CURB INLET 2	TYPE D CURB INLET RIM: 569.65 INV OUT: 562.99 (18" RCP, SE)
PR GARAGE CURB INLET 3	TYPE D CURB INLET RIM: 569.65 INV OUT: 560.80 (15" RCP, SE)
STMH-445	CONNECT TO EXISTING MH RIM: 571.96 INV IN: 560.47 (24" RCP, S) INV OUT: 560.46 (27" RCP, E)
STMH-447	CONNECT TO EXISTING MH RIM: 569.73 INV IN: 560.74 (24" RCP, N) INV IN: 560.00 (24" RCP, S) INV IN: 560.00 (27" RCP, W) INV OUT: 560.06 (42" RCP, E)
STMH-448	CONNECT TO EXISTING MH RIM: 569.91 INV IN: 559.41 (42" RCP, SW) INV IN: 560.48 (24" RCP, NW) INV IN: 560.48 (30" RCP, SE) INV OUT: 559.41 (51" RCP, NE)
STMH-449	CONNECT TO EXISTING MH RIM: 570.17 INV IN: 559.20 (51" RCP, SW) INV OUT: 560.46 (27" RCP, SE)
STMH-450	CONNECT TO EXISTING MH RIM: 570.01 INV IN: 558.80 (51" RCP, SW) INV IN: 559.12 (30" RCP, SE) INV OUT: 558.80 (54" RCP, NE)
STMH-452	CONNECT TO EXISTING STRUCTURE RIM: 567.49 INV IN: 558.66 (54" RCP, SW) INV IN: 559.16 (66" RCP, NW) INV IN: 560.28 (38" RCP, N) INV OUT: 558.66 (78" RCP, SE)
STMH-461	CONNECT TO EXISTING MH RIM: 580.39 INV IN: 561.75 (48" RCP, NW) INV OUT: 561.75 (48" RCP, SE)
STMH-463	CONNECT TO EXISTING MH RIM: 573.87 INV IN: 561.05 (48" RCP, NW) INV OUT: 559.68 (66" RCP, SE)
STMH-30073	CONNECT TO EXISTING MH RIM: 570.67 INV IN: 560.96 (30" RCP, E) INV OUT: 560.96 (38" RCP, S)

EXISTING LEGEND

- CRIADO CONTROL POINT
- IRON ROD FOUND
- BOLLARD
- GAS METER
- TRAFFIC SIGNAL LIGHT POLE
- TRAFFIC SIGNAL PULL BOX
- TRAFFIC SIGNAL CONTROL BOX
- TELECOM SERVICE BOX
- TELECOM PEDESTAL
- CATV PEDESTAL
- CATV JUNCTION BOX
- CATV APPURTENANCE
- LIGHT POLE
- CATHODIC PROTECTION FLAG POLE
- GENERIC MANHOLE
- POWER POLE
- GUYWIRE
- ELECTRIC MANHOLE
- ELECTRIC PULL BOX
- ELECTRIC METER
- ELECTRIC BOX
- ELECTRIC RISER
- GROUND LIGHT SIGN
- GAS PUMP
- FUEL TANK VENT TREE
- BUSH
- WASTE WATER CLEANOUT
- WASTE WATER MANHOLE
- STORM DRAIN MANHOLE
- WATER VALVE
- IRRIGATION CONTROL VALVE
- SPRINKLER HEAD
- WIP
- FIRE HYDRANT
- WATER METER
- OVERHEAD UTILITY
- OVERHEAD ELECTRIC

EXISTING UTILITY LEGEND

- (E) — DFW AIRPORT - ELECTRIC (LVL-B)
- (E10) — DFW AIRPORT - ELECTRIC (LVL-D)
- (F001) — FAA - (LVL-B)
- (F001D) — FAA - (LVL-D)
- (T00) — FAA - (LVL-D)
- (F002C) — FRONTIER (LVL-B)
- (F002D) — FRONTIER (LVL-D)
- (W) — DFW AIRPORT - WATER (LVL-B)
- (W10) — DFW AIRPORT - WATER (LVL-D)
- (W10D) — DFW AIRPORT - WASTEWATER (LVL-D)
- (W10D) — DFW AIRPORT - STORM DRAIN (LVL-D)
- (E10D) — EXPLORER PIPELINE - PETROLEUM (LVL-B)
- (E10D) — EXPLORER PIPELINE - PETROLEUM (LVL-D)
- (E10D) — ALLIED AVIATION - JET FUEL (LVL-D)

PROPOSED LEGEND

- (S) — PROPOSED STORM SEWER
- (S1) — PROPOSED STORM SEWER LINING
- — PROPOSED STORM STRUCTURE

GENERAL NOTES

- STORM SEWER WORK FOR CAROUSEL ROAD TO BE INCLUDED AS A PART OF PHASE 1 WORK. STORM SEWER WORK BETWEEN PARKING GARAGE C AND PARKING GARAGE B TO BE INCLUDED AS A PART OF PHASE 2 WORK.
- EXISTING STORM SEWER LINE MAY CONTAIN ASBESTOS MASTICS OR SEALANTS AT RCP JOINTS. CONTACT EAD FOR INSPECTION ONCE THE STORM SEWER LINE IS EXPOSED.
- ALL STORM DRAIN LINES SHALL BE INSPECTED AND CLEANED THAN VIDEOED SYSTEM, AND REVIEWED BY CONTRACTOR BEFORE A COPY OF THE RESULTS ARE SENT TO DESIGN, CODE AND CONSTRUCTION FOR APPROVAL.
- PVC AND POLYETHYLENE PIPE CONNECTIONS TO RCP SHALL BE INSTALLED WITH INSERTA TEE CONNECTIONS.
- FORMED CONCRETE COLLARS WITH 2 LOOPS OF #3 REBAR WITH CROSS PIECES AT 12CENTR SHALL BE AT ALL CONNECTIONS AT INLETS, MANHOLES AND ALL PIPES TIE-INS.
- RAM-NEK SHALL BE CUT SMOOTH IN THE INSIDE OF RCP TO ALLOW PROPER FLOW.
- FILTER FABRIC SHALL BE LAID ON TOP OF ALL RCP JOINTS.
- BEDDING FOR RCP SHALL BE LAID TO NO LESS THAN SPRING LINE OF THE PIPE.
- PVC PIPE SHALL BE BEDDED WITH #10 CHAT OR CUSHION SAND TO 6" BELOW AND 12" ON TOP WITH MARKING TAPE
- ALL STORM MANHOLES TO BE RELINED WITH CCCP OR CIPP LINING MATCHING TYPE USED IN ADJOINING PIPE. INSTALL NEW MANHOLES STEPS PER TXDOT AND ASTM C478 "MANHOLE STEPS AND LADDERS".

KEY PLAN

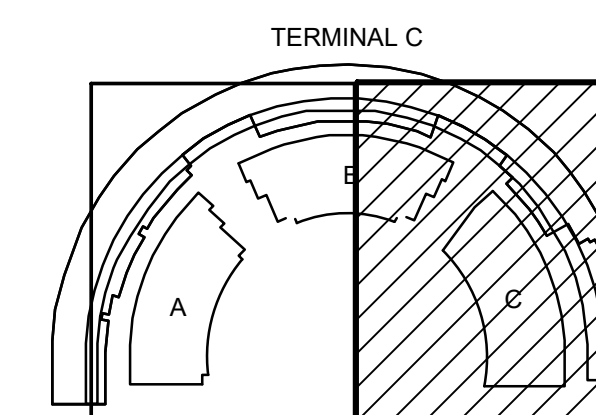

STORM CONNECTION TABLE

NAME:	DETAILS:
WYE-500	PROPOSED WYE CONNECTION INV IN: 559.46 (42" RCP, SW) INV IN: 559.46 (15" RCP, NW) INV OUT: 559.46 (42" RCP, NE)
WYE-600	PROPOSED WYE CONNECTION INV IN: 559.34 (51" RCP, SW) INV IN: 560.30 (15" RCP, NW) INV OUT: 559.34 (51" RCP, NE)
WYE-700	PROPOSED WYE CONNECTION INV IN: 558.98 (51" RCP, SW) INV IN: 558.97 (24" RCP, W) INV OUT: 558.98 (51" RCP, NE)
WYE-800	PROPOSED WYE CONNECTION INV IN: 560.33 (38" RCP, N) INV IN: 560.33 (24" RCP, NW) INV OUT: 560.33 (38" RCP, S)
WYE-900	PROPOSED WYE CONNECTION INV IN: 560.94 (38" RCP, N) INV IN: 560.94 (24" RCP, NW) INV OUT: 560.94 (38" RCP, S)
TD-1	CONNECT TO TRENCH DRAIN INV IN: 565.92 (12" RCP, N) INV OUT: 566.00 (12" RCP, SE)
TD-2	CONNECT TO TRENCH DRAIN INV IN: 565.77 (12" RCP, E) INV OUT: 565.77 (12" RCP, E)
WYE-100	PROPOSED WYE CONNECTION INV IN: 560.46 (27" RCP, W) INV IN: 560.42 (24" RCP, NW) INV OUT: 560.28 (27" RCP, E)
WYE-190	PROPOSED WYE CONNECTION INV IN: 559.49 (66" RCP, NW) INV IN: 561.74 (12" RCP, SW) INV OUT: 559.49 (66" RCP, SE)
WYE-200	PROPOSED WYE CONNECTION INV IN: 560.15 (27" RCP, W) INV IN: 560.77 (12" RCP, NW) INV OUT: 560.15 (27" RCP, E)
WYE-210	PROPOSED WYE CONNECTION INV IN: 561.22 (48" RCP, NW) INV IN: 563.57 (12" RCP, W) INV OUT: 561.22 (48" RCP, SE)
WYE-300	PROPOSED WYE CONNECTION INV IN: 560.80 (42" RCP, W) INV IN: 560.51 (24" RCP, NW) INV OUT: 559.73 (42" RCP, E)

STORM CONNECTION TABLE

NAME:	DETAILS:
CI-700255	CIPP LINE 10 LF OF 24" RCP
CI-30109	CIPP LINE 10 LF OF 24" RCP
CI-30125	CIPP LINE 15 LF OF 24" RCP
CI-30135	CIPP LINE 17 LF OF 24" RCP
CI-31500	CIPP LINE 18 LF OF 24" RCP
CI-7748	CIPP LINE 18 LF OF 12" RCP
CI-30109	CIPP LINE 19 LF OF 24" RCP
CI-30125	CIPP LINE 19 LF OF 24" RCP
CI-30135	CIPP LINE 19 LF OF 24" RCP
CI-31500	CIPP LINE 19 LF OF 24" RCP
CI-700255	CIPP LINE 19 LF OF 24" RCP
CI-30109	CIPP LINE 25 LF OF 15" RCP
CI-30125	CIPP LINE 25 LF OF 15" RCP
CI-30135	CIPP LINE 25 LF OF 15" RCP
CI-31500	CIPP LINE 25 LF OF 15" RCP
CI-7748	CIPP LINE 25 LF OF 15" RCP
CI-30109	CIPP LINE 25 LF OF 15" RCP
CI-30125	CIPP LINE 25 LF OF 15" RCP
CI-30135	CIPP LINE 25 LF OF 15" RCP
CI-31500	CIPP LINE 25 LF OF 15" RCP
CI-7748	CIPP LINE 25 LF OF 15" RCP
CI-30109	CIPP LINE 25 LF OF 15" RCP
CI-30125	CIPP LINE 25 LF OF 15" RCP
CI-30135	CIPP LINE 25 LF OF 15" RCP
CI-31500	CIPP LINE 25 LF OF 15" RCP
CI-7748	CIPP LINE 25 LF OF 15" RCP
CI-30109	CIPP LINE 25 LF OF 15" RCP
CI-30125	CIPP LINE 25 LF OF 15" RCP
CI-30135	CIPP LINE 25 LF OF 15" RCP
CI-31500	CIPP LINE 25 LF OF 15" RCP
CI-7748	CIPP LINE 25 LF OF 15" RCP
CI-30109	CIPP LINE 25 LF OF 15" RCP
CI-30125	CIPP LINE 25 LF OF 15" RCP
CI-30135	CIPP LINE 25 LF OF 15" RCP
CI-31500	CIPP LINE 25 LF OF 15" RCP
CI-7748	CIPP LINE 25 LF OF 15" RCP
CI-30109	CIPP LINE 25 LF OF 15" RCP
CI-30125	CIPP LINE 25 LF OF 15" RCP
CI-30135	CIPP LINE 25 LF OF 15" RCP
CI-31500	CIPP LINE 25 LF OF 15" RCP
CI-7748	CIPP LINE 25 LF OF 15" RCP
CI-30109	CIPP LINE 25 LF OF 15" RCP
CI-30125	CIPP LINE 25 LF OF 15" RCP
CI-30135	CIPP LINE 25 LF OF 15" RCP
CI-31500	CIPP LINE 25 LF OF 15" RCP
CI-7748	CIPP LINE 25 LF OF 15" RCP
CI-30109	CIPP LINE 25 LF OF 15" RCP
CI-30125	CIPP LINE 25 LF OF 15" RCP
CI-30135	CIPP LINE 25 LF OF 15" RCP
CI-31500	CIPP LINE 25 LF OF 15" RCP
CI-7748	CIPP LINE 25 LF OF 15" RCP
CI-30109	CIPP LINE 25 LF OF 15" RCP
CI-30125	CIPP LINE 25 LF OF 15" RCP
CI-30135	CIPP LINE 25 LF OF 15" RCP
CI-31500	CIPP LINE 25 LF OF 15" RCP
CI-7748	CIPP LINE 25 LF OF 15" RCP
CI-30109	CIPP LINE 25 LF OF 15" RCP
CI-30125	CIPP LINE 25 LF OF 15" RCP
CI-30135	CIPP LINE 25 LF OF 15" RCP
CI-31500	CIPP LINE 25 LF OF 15" RCP
CI-7748	CIPP LINE 25 LF OF 15" RCP
CI-30109	CIPP LINE 25 LF OF 15" RCP
CI-30125	CIPP LINE 25 LF OF 15" RCP
CI-30135	CIPP LINE 25 LF OF 15" RCP
CI-31500	CIPP LINE 25 LF OF 15" RCP
CI-7748	CIPP LINE 25 LF OF 15" RCP
CI-30109	CIPP LINE 25 LF OF 15" RCP
CI-30125	CIPP LINE 25 LF OF 15" RCP
CI-30135	CIPP LINE 25 LF OF 15" RCP
CI-31500	CIPP LINE 25 LF OF 15" RCP
CI-7748	CIPP LINE 25 LF OF 15" RCP
CI-30109	CIPP LINE 25 LF OF 15" RCP
CI-30125	CIPP LINE 25 LF OF 15" RCP
CI-30135	CIPP LINE 25 LF OF 15" RCP
CI-31500	CIPP LINE 25 LF OF 15" RCP
CI-7748	CIPP LINE 25 LF OF 15" RCP
CI-30109	CIPP LINE 25 LF OF 15" RCP
CI-30125	CIPP LINE 25 LF OF 15" RCP
CI-30135	CIPP LINE 25 LF OF 15" RCP
CI-31500	CIPP LINE 25 LF OF 15" RCP
CI-7748	CIPP LINE 25 LF OF 15" RCP
CI-30109	CIPP LINE 25 LF OF 15" RCP
CI-30125	CIPP LINE 25 LF OF 15" RCP
CI-30135	CIPP LINE 25 LF OF 15" RCP
CI-31500	CIPP LINE 25 LF OF 15" RCP
CI-7748	CIPP LINE 25 LF OF 15" RCP
CI-30109	CIPP LINE 25 LF OF 15" RCP
CI-30125	CIPP LINE 25 LF OF 15" RCP
CI-30135	CIPP LINE 25 LF OF 15" RCP
CI-31500	CIPP LINE 25 LF OF 15" RCP
CI-7748	CIPP LINE 25 LF OF 15" RCP
CI-30109	CIPP LINE 25 LF OF 15" RCP
CI-30125	CIPP LINE 25 LF OF 15" RCP
CI-30135	CIPP LINE 25 LF OF 15" RCP
CI-31500	CIPP LINE 25 LF OF 15" RCP
CI-7748	CIPP LINE 25 LF OF 15" RCP
CI-30109	CIPP LINE 25 LF OF 15" RCP
CI-30125	CIPP LINE 25 LF OF 15" RCP
CI-30135	CIPP LINE 25 LF OF 15" RCP
CI-31500	CIPP LINE 25 LF OF 15" RCP
CI-7748	CIPP LINE 25 LF OF 15" RCP
CI-30109	CIPP LINE 25 LF OF 15" RCP
CI-30125	CIPP LINE 25 LF OF 15" RCP
CI-30135	CIPP LINE 25 LF OF 15" RCP
CI-31500	CIPP LINE 25 LF OF 15" RCP
CI-7748	CIPP LINE 25 LF OF 15" RCP
CI-30109	CIPP LINE 25 LF OF 15" RCP
CI-30125	CIPP LINE 25 LF OF 15" RCP
CI-30135	CIPP LINE 25 LF OF 15" RCP
CI-31500	CIPP LINE 25 LF OF 15" RCP
CI-7748	CIPP LINE 25 LF OF 15" RCP
CI-30109	CIPP LINE 25 LF OF 15" RCP
CI-30125	CIPP LINE 25 LF OF 15" RCP
CI-30135	CIPP LINE 25 LF OF 15" RCP
CI-31500	CIPP LINE 25 LF OF 15" RCP
CI-7748	CIPP LINE 25 LF OF 15" RCP
CI-30109	CIPP LINE 25 LF OF 15" RCP
CI-30125	CIPP LINE 25 LF OF 15" RCP
CI-30135	CIPP LINE 25 LF OF 15" RCP
CI-31500	CIPP LINE 25 LF OF 15" RCP
CI-7748	CIPP LINE 25 LF OF 15" RCP
CI-30109	CIPP LINE 25 LF OF 15" RCP
CI-30125	CIPP LINE 25 LF OF 15" RCP
CI-30135	CIPP LINE 25 LF OF 15" RCP
CI-31500	CIPP LINE 25 LF OF 15" RCP
CI-7748	CIPP LINE 25 LF OF 15" RCP
CI-30109	CIPP LINE 25 LF OF 15" RCP
CI-30125	CIPP LINE 25 LF OF 15" RCP
CI-30135	CIPP LINE 25 LF OF 15" RCP
CI-31500	CIPP LINE 25 LF OF 15" RCP
CI-7748	CIPP LINE 25 LF OF 15" RCP
CI-30109	CIPP LINE 25 LF OF 15" RCP
CI-30125	CIPP LINE 25 LF OF 15" RCP
CI-30135	CIPP LINE 25 LF OF 15" RCP
CI-31500	CIPP LINE 25 LF OF 15" RCP
CI-7748	CIPP LINE 25 LF OF 15" RCP
CI-30109	CIPP LINE 25 LF OF 15" RCP
CI-30125	CIPP LINE 25 LF OF 15" RCP
CI-30135	CIPP LINE 25 LF OF 15" RCP
CI-31500	CIPP LINE 25 LF OF 15" RCP
CI-7748	CIPP LINE 25 LF OF 15" RCP
CI-30109	CIPP LINE 25 LF OF 15" RCP
CI-30125	CIPP LINE 25 LF OF 15" RCP
CI-30135	CIPP LINE 25 LF OF 15" RCP
CI-31500	CIPP LINE 25 LF OF 15" RCP
CI-7748	CIPP LINE 25 LF OF 15" RCP
CI-30109	CIPP LINE 25 LF OF 15" RCP
CI-30125	CIPP LINE 25 LF OF 15" RCP
CI-30135	CIPP LINE 25 LF OF 15" RCP
CI-31500	CIPP LINE 25 LF OF 15" RCP
CI-7748	CIPP LINE 25 LF OF 15" RCP
CI-30109	CIPP LINE 25 LF OF 15" RCP
CI-30125	CIPP LINE 25 LF OF 15" RCP
CI-30135	CIPP LINE 25 LF OF 15" RCP
CI-31500	CIPP LINE 25 LF OF 15" RCP
CI-7748	CIPP LINE 25 LF OF 15" RCP
CI-30109	CIPP LINE 25 LF OF 15" RCP
CI-30125	CIPP LINE 25 LF OF 15" RCP
CI-30135	CIPP LINE 25 LF OF 15" RCP
CI-31500	CIPP LINE 25 LF OF 15" RCP
CI-7748	CIPP LINE 25 LF OF 15" RCP
CI-30109	CIPP LINE 25 LF OF 15" RCP
CI-30125	CIPP LINE 25 LF OF 15" RCP
CI-30135	CIPP LINE 25 LF OF 15" RCP
CI-31500	CIPP LINE 25 LF OF 15" RCP
CI-7748	CIPP LINE 25 LF OF 15" RCP
CI-30109	CIPP LINE 25 LF OF 15" RCP
CI-30125	CIPP LINE 25 LF OF 15" RCP
CI-30135	CIPP LINE 25 LF OF 15" RCP
CI-31500	CIPP LINE 25 LF OF 15" RCP
CI-7748	CIPP LINE 25 LF OF 15" RCP
CI-30109	CIPP LINE 25 LF OF 15" RCP
CI-30125	CIPP LINE 25 LF OF 15" RCP
CI-30135	CIPP LINE 25 LF OF 15" RCP
CI-31500	CIPP LINE 25 LF OF 15" RCP
CI-7748	CIPP LINE 25 LF OF 15" RCP
CI-30109	CIPP LINE 25 LF OF 15" RCP
CI-30125	CIPP LINE 25 LF OF 15" RCP
CI-30135	CIPP LINE 25 LF OF 15" RCP
CI-31500	CIPP LINE 25 LF OF 15" RCP
CI-7748	CIPP LINE 25 LF OF 15" RCP
CI-30109	CIPP LINE 25 LF OF 15" RCP
CI-30125	CIPP LINE 25 LF OF 15" RCP
CI-30135	C

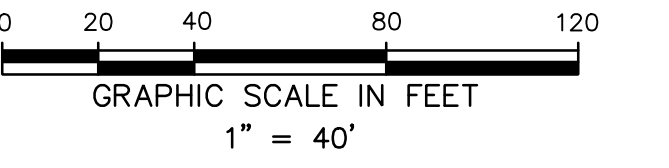

T1H1 PROFILE

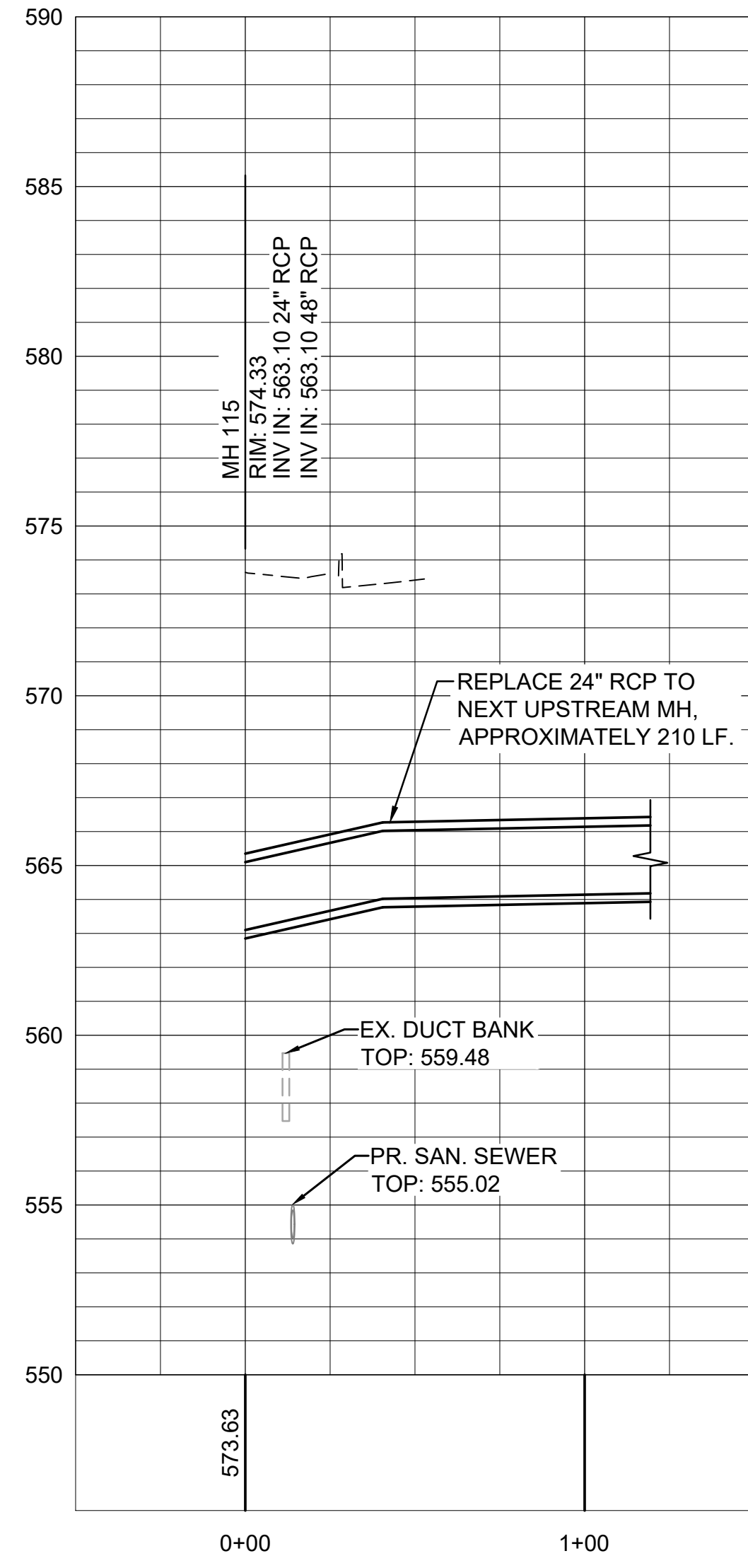

EX CI 180 PROFILE

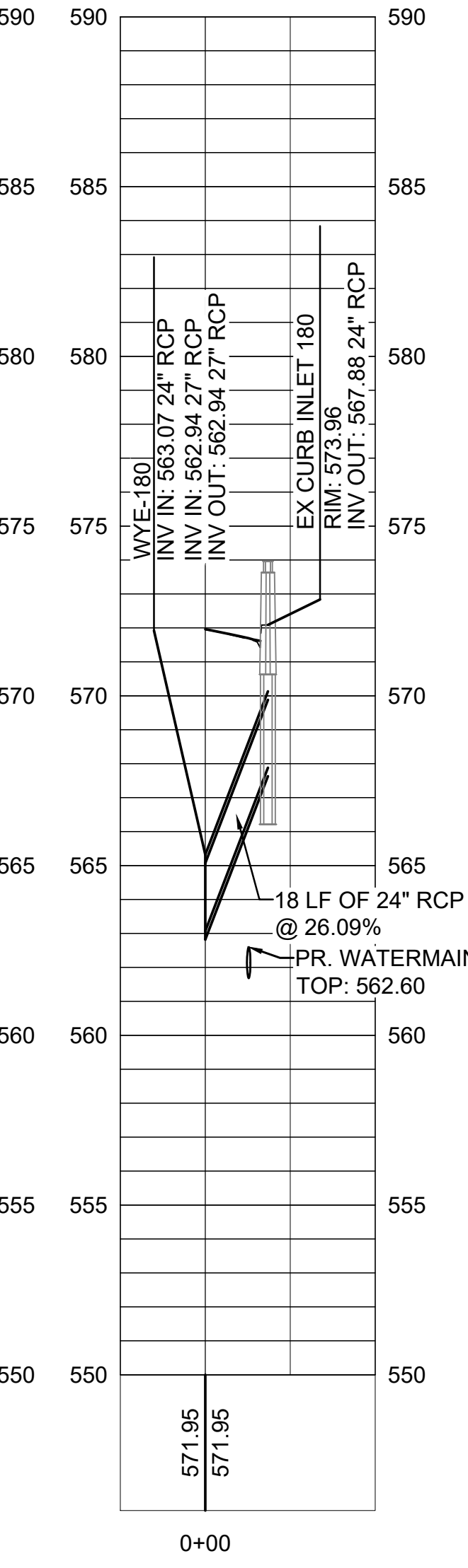

T1H2 PROFILE

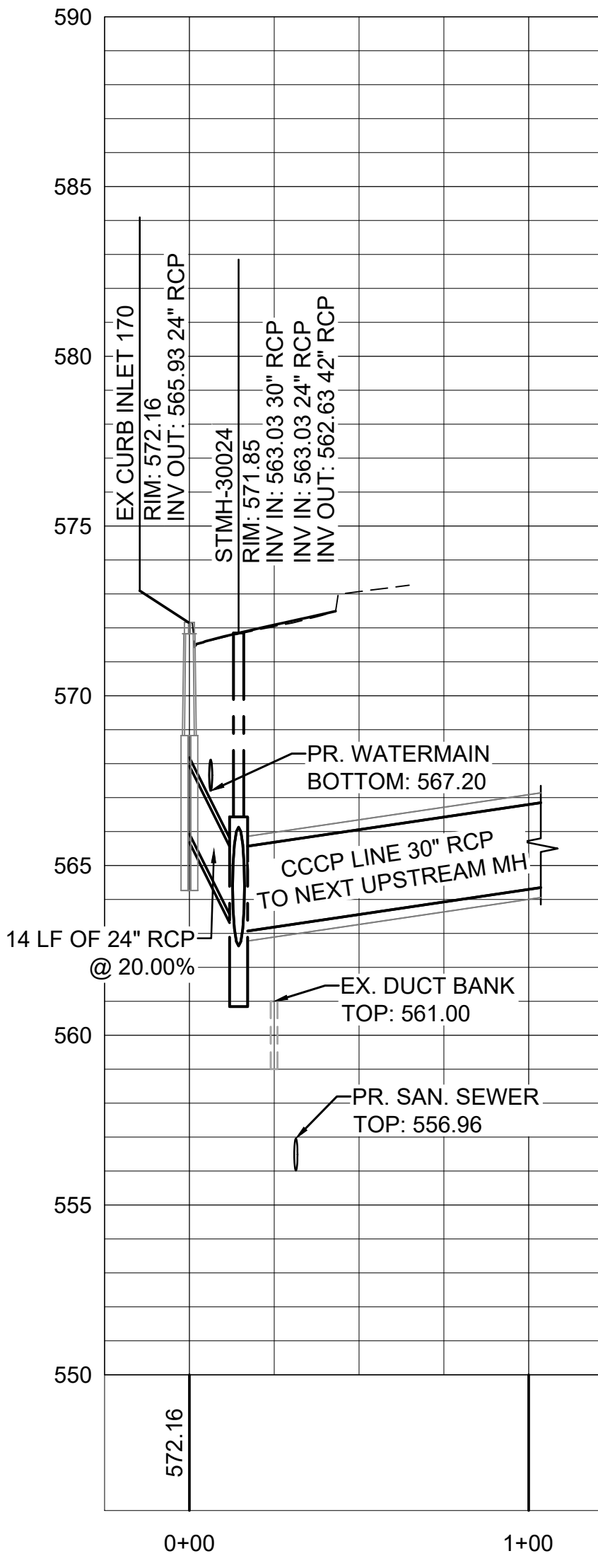

EX CI 160 PROFILE

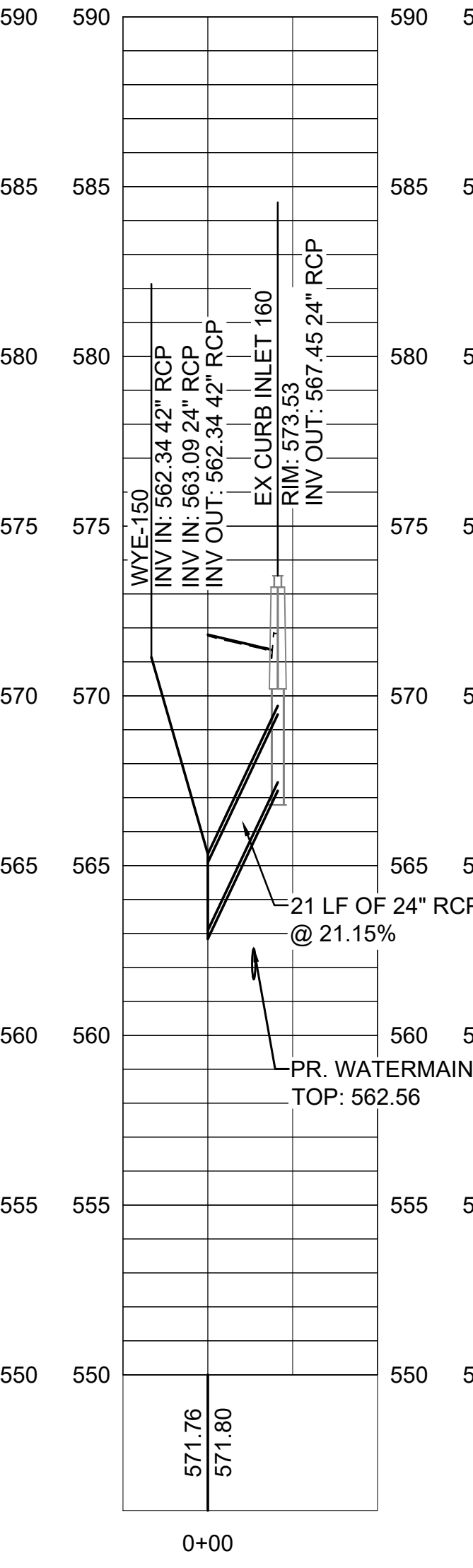

EX CI 150 PROFILE

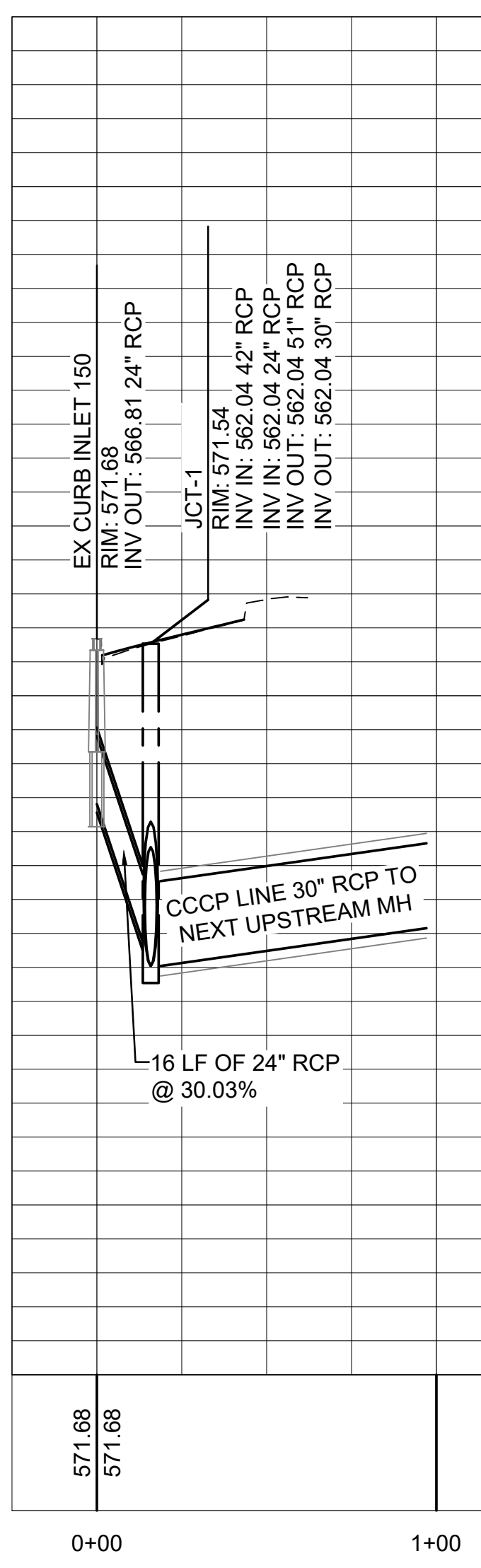

CI-6683 PROFILE

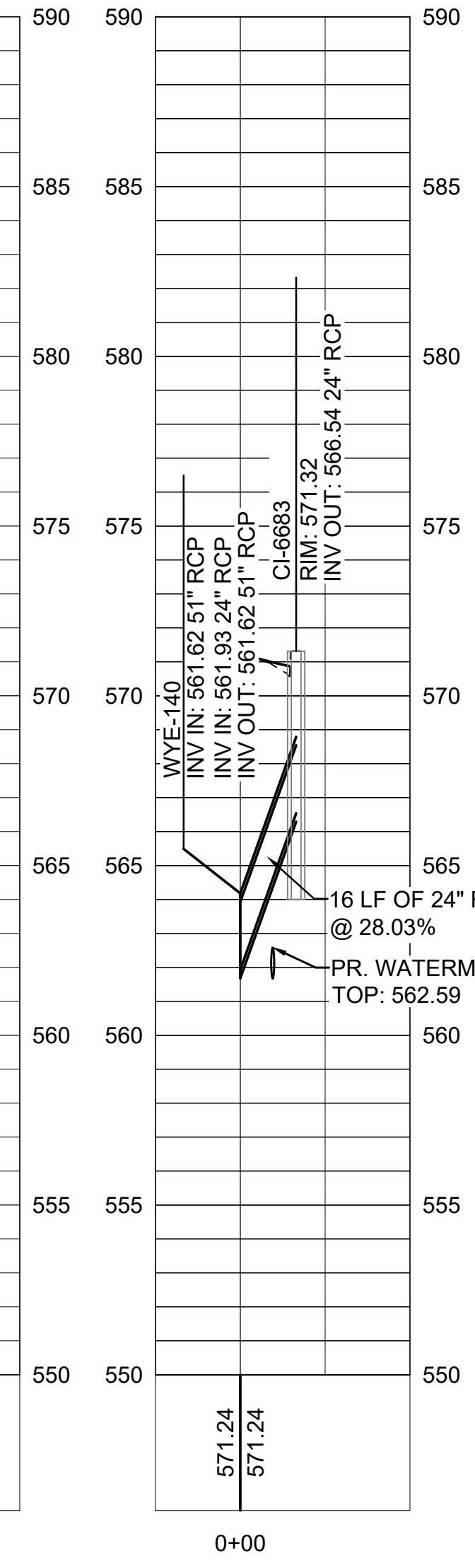

T1H4 PROFILE

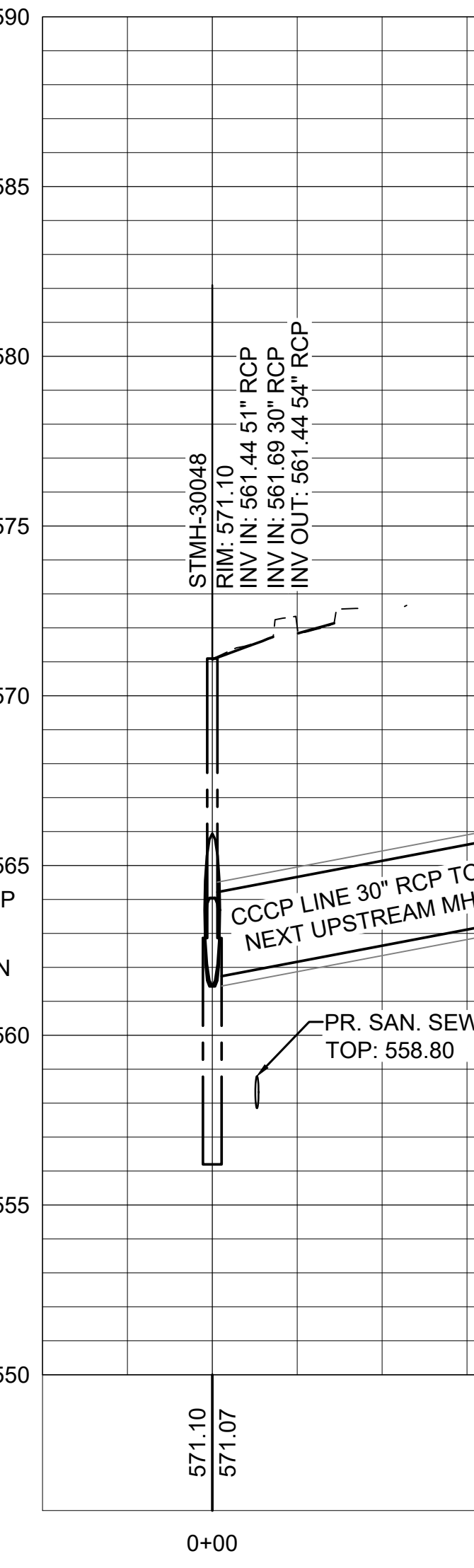

TIK PROFILE

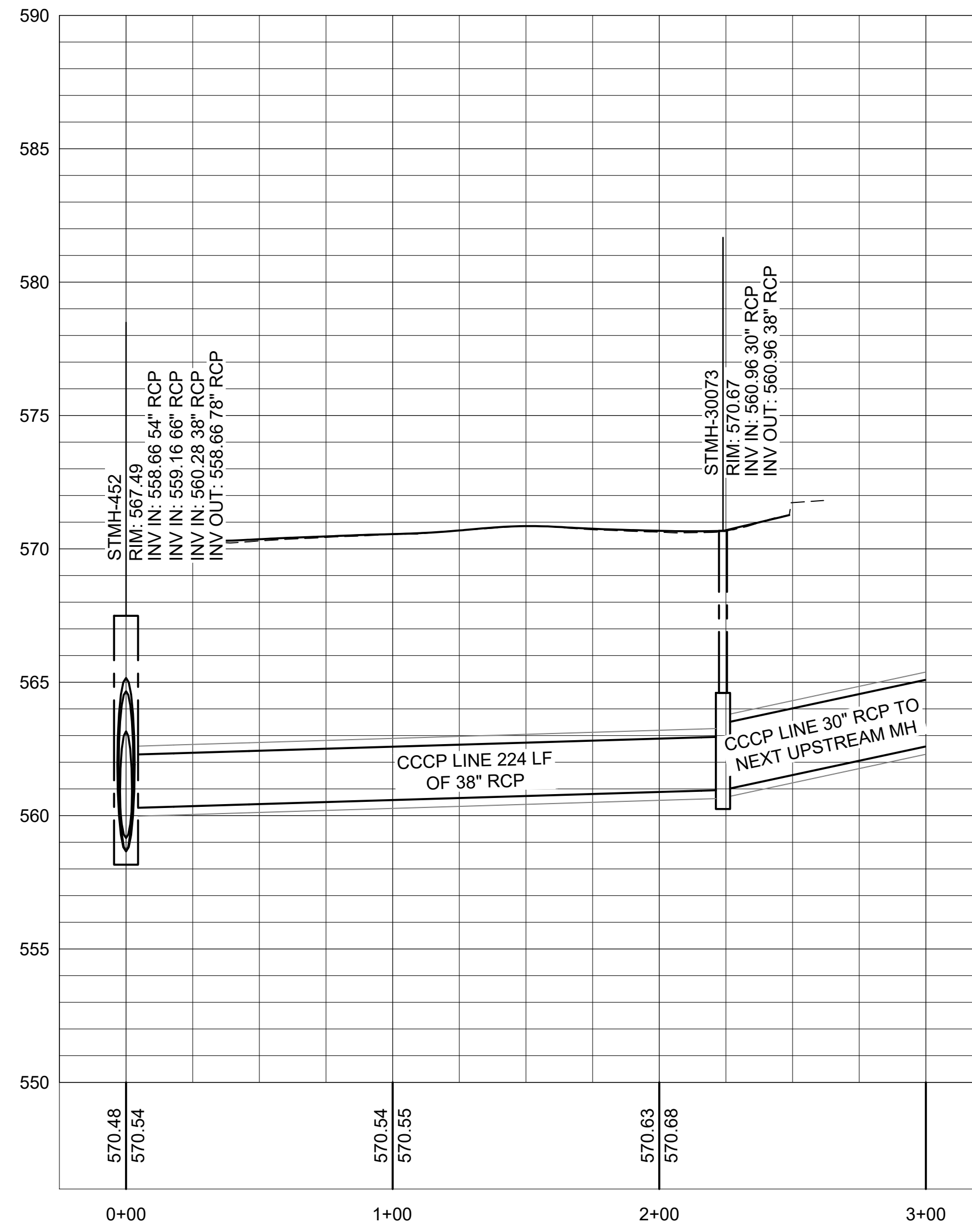

T1G15 T1H & T1H5 PROFILE

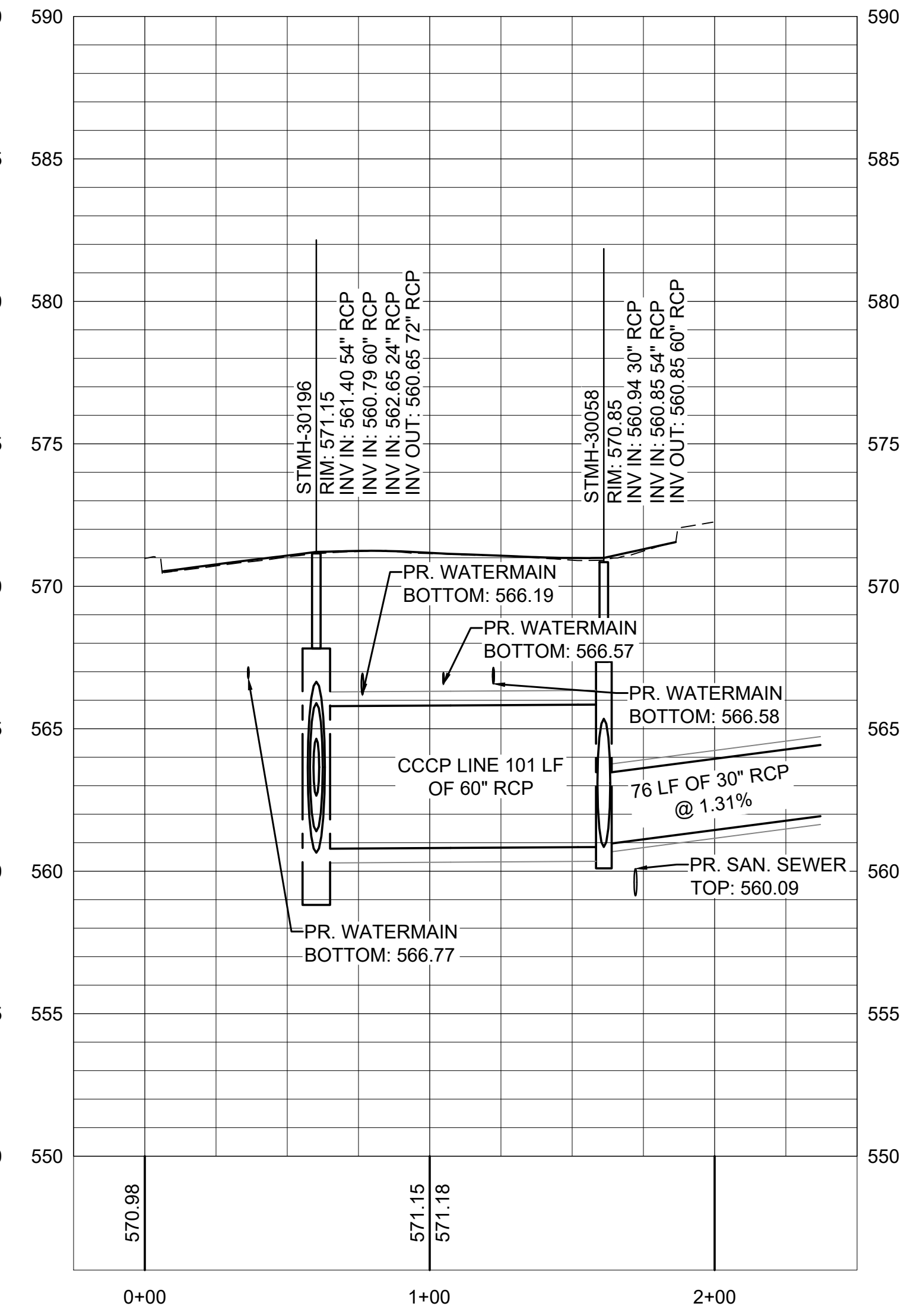

BORDER RELEASE DATE: October 16, 2021
 01/20/2021 1:45:09 PM
 C:\Users\jrc2\OneDrive\Documents\HOV\DAL\DFW\Int'l Airport - CTA Expansion Program\Project Files\01_CTA - Terminal C Garages and Roadways\CE\01 - CAD\Sheets\800\802-DFW-TC-CI20-0-0200_StormProfiles.dwg



DALLAS
 FORT WORTH
 INTERNATIONAL
 AIRPORT

2330 N INTERNATIONAL PARKWAY
 DFW AIRPORT, TX 75261



Heidi Ruth, Chief Engineer, Inc.
 777 North Central Expressway
 Suite 2000, L.B. #1
 Dallas, TX 75201
 (+1) 214 720 8900

DRAWN BY: JNB
 APPROVED BY: JMA
 ISSUE DATE: 2022-07-28
NOT FOR BID OR CONSTRUCTION

NO.	DATE	DESCRIPTION
1	2022-01-08	30% DESIGN
2	2022-05-01	100% DESIGN
3	2022-07-28	100% REVISED FOR PERMIT (RFP)

PROJECT NUMBER: TFD-007

TERMINAL C GARAGE & ROADWAYS
STORM SEWER PROFILES

PERMIT NUMBER: B22-0023

SHEET NUMBER
CU201-900R

SCALE(S) AS NOTED ON THIS SHEET ARE BASED ON A FULL SIZE 30 X 42 SHEET.

T1Y S & T1I W PROFILE

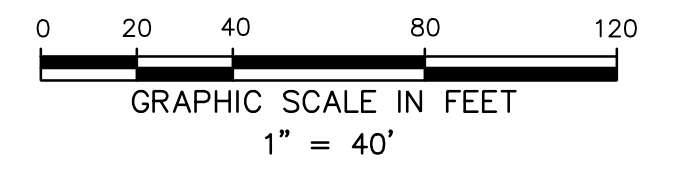
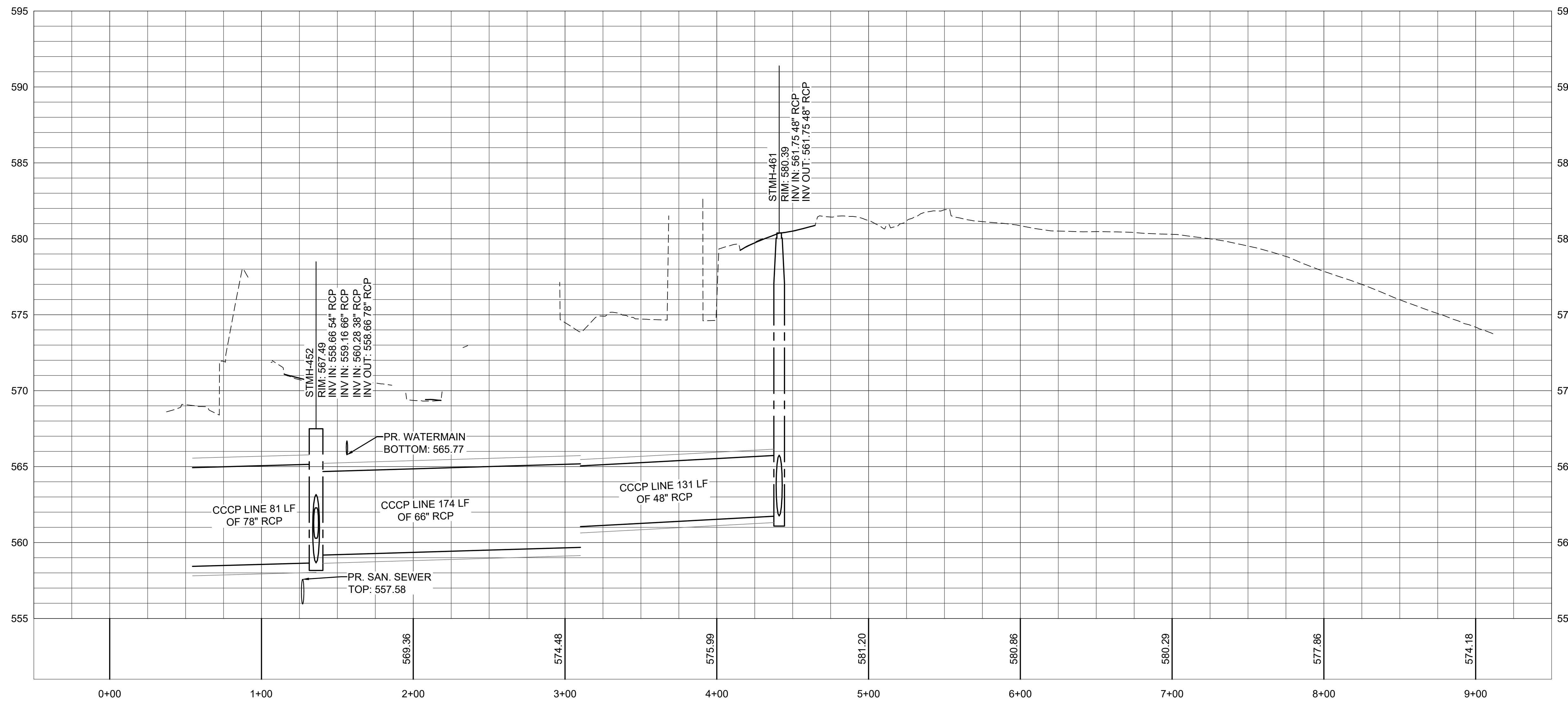

STMH-30196 PROFILE

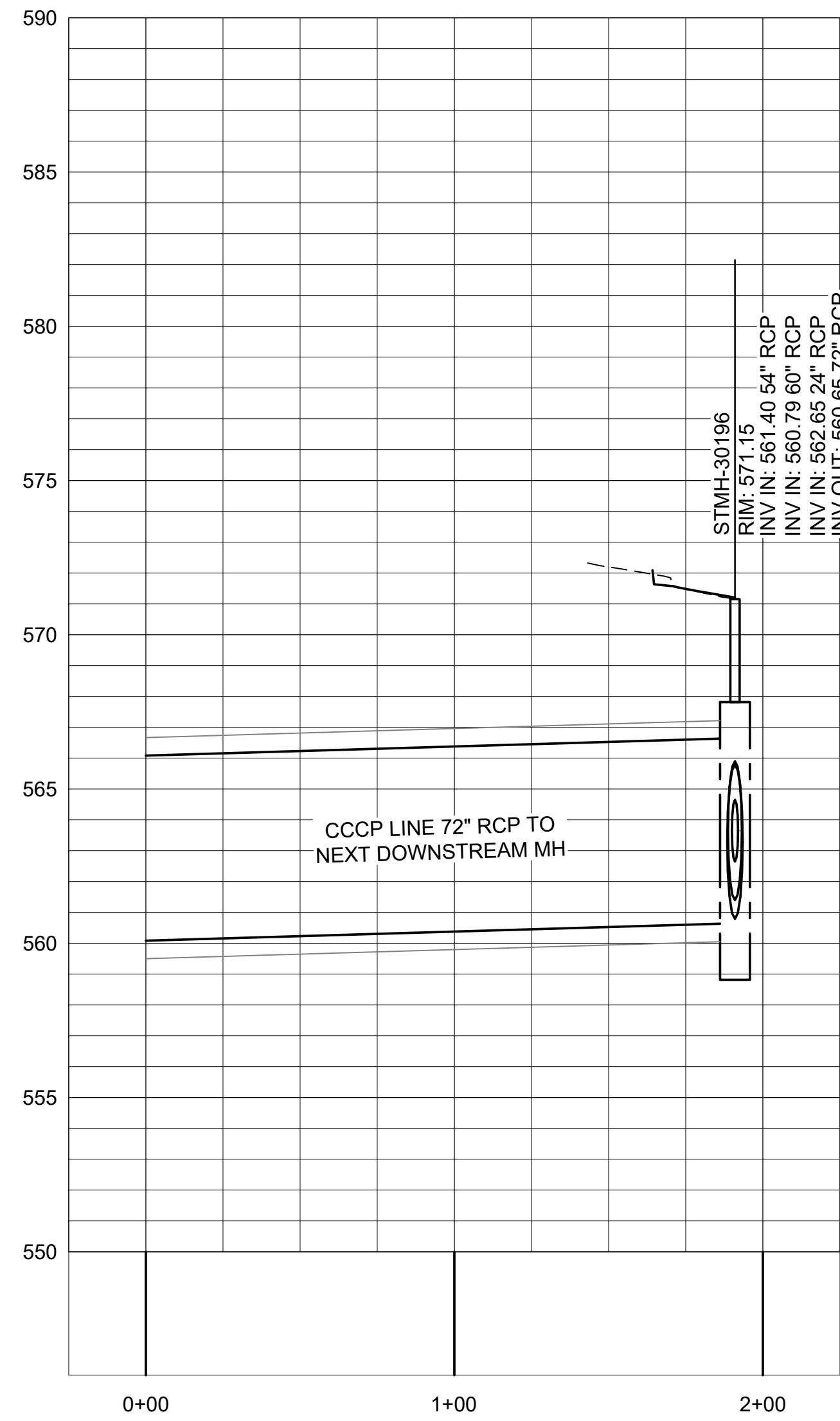

T1K5 PROFILE

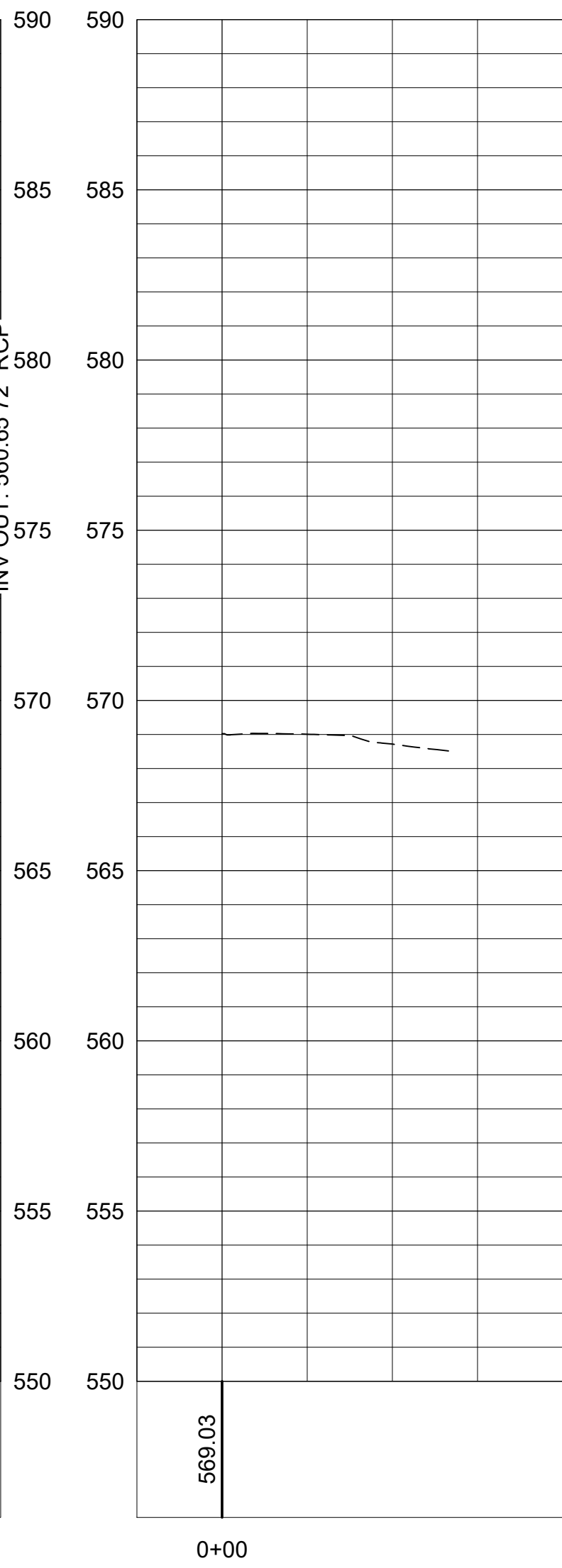

T1K N T1K & T1K3 PROFILE

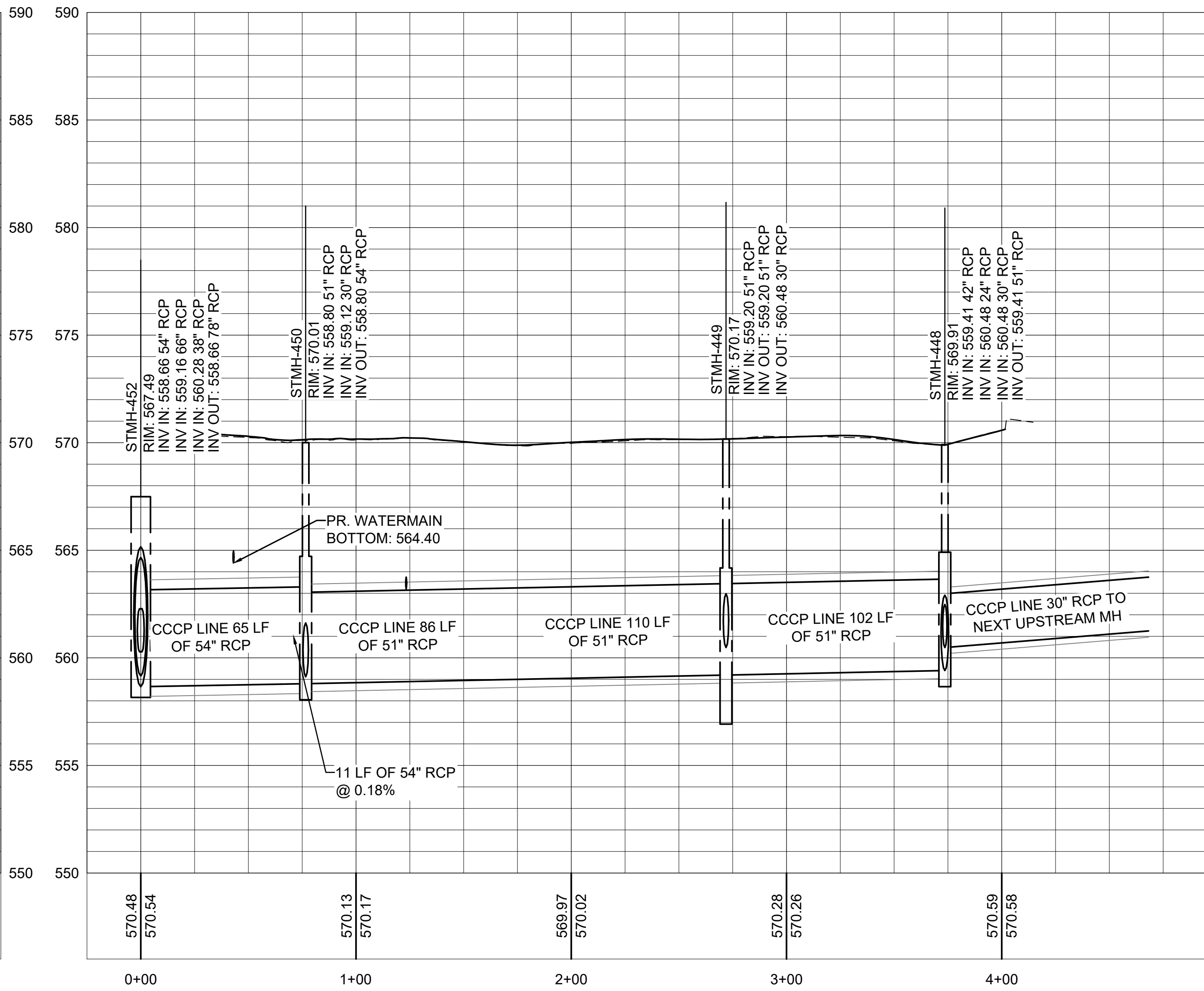

T1K4 PROFILE

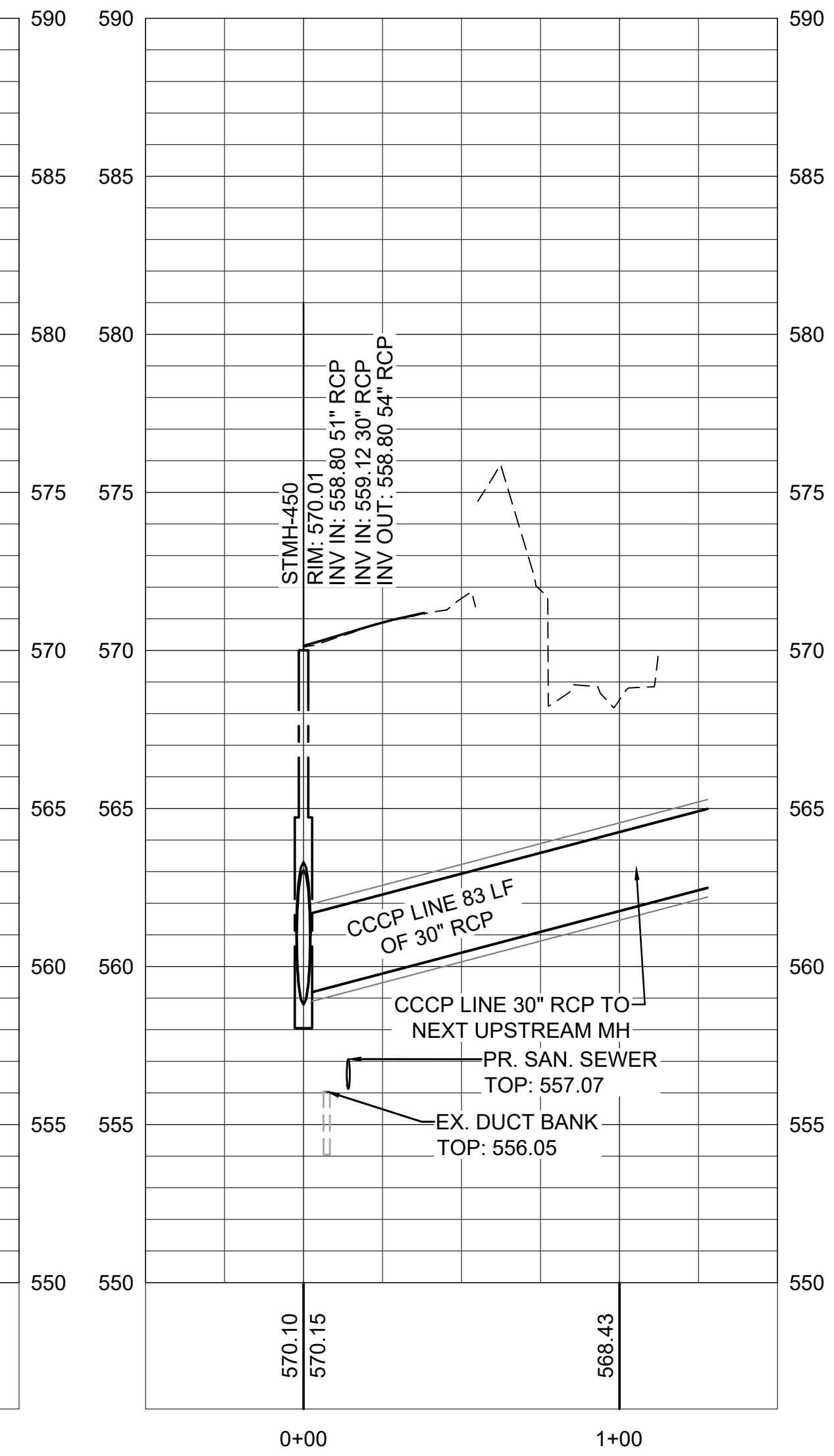

BORDER RELEASE DATE: October 16, 2021
01/20/2021 10:09:09 AM
C:\Users\jmc\OneDrive\Documents\HOK\DAL\DFW Int'l Airport - CTA Expansion Program\Project Files\01_CTA - Terminal C Garages and Roadways and Revit\06_CE\01 - CAD\Sheets\010025-DFW-TC-0120-0-0200_StormProfile.dwg



DALLAS
FORT WORTH
INTERNATIONAL
AIRPORT

2330 N INTERNATIONAL PARKWAY
DFW AIRPORT, TX 75261

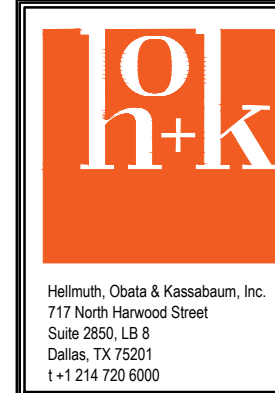

Heidrich, Christ & Krasbaum, Inc.
777 North Central Expressway
Dallas, TX 75201
+1 214 720 9000

Primera Engineers, Ltd.
3000 Ross Road
Suite 214
Dallas, TX 75201
+1 214 606 0910

DRAWN BY: JNB
APPROVED BY: JMA
ISSUE DATE: 2022-07-28

**NOT FOR BID OR
CONSTRUCTION**

NO.	DATE	DESCRIPTION
1	2022-01-08	30% DESIGN
2	2022-05-01	100% DESIGN
3	2022-07-28	100% REVISED FOR PERMIT (RFP)

TERMINAL C GARAGE & ROADWAYS
STORM SEWER PROFILES

PROJECT NUMBER: TFD-007

PERMIT NUMBER: B22-0023

SHEET NUMBER
CU202-900R

SCALE(S) AS NOTED ON THIS SHEET ARE BASED ON A FULL SIZE 30 X 42 SHEET.

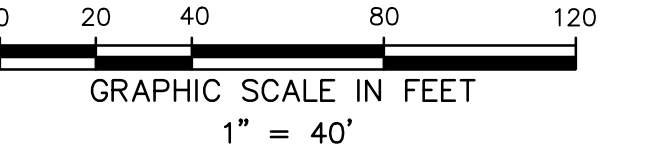

T1K6 PROFILE

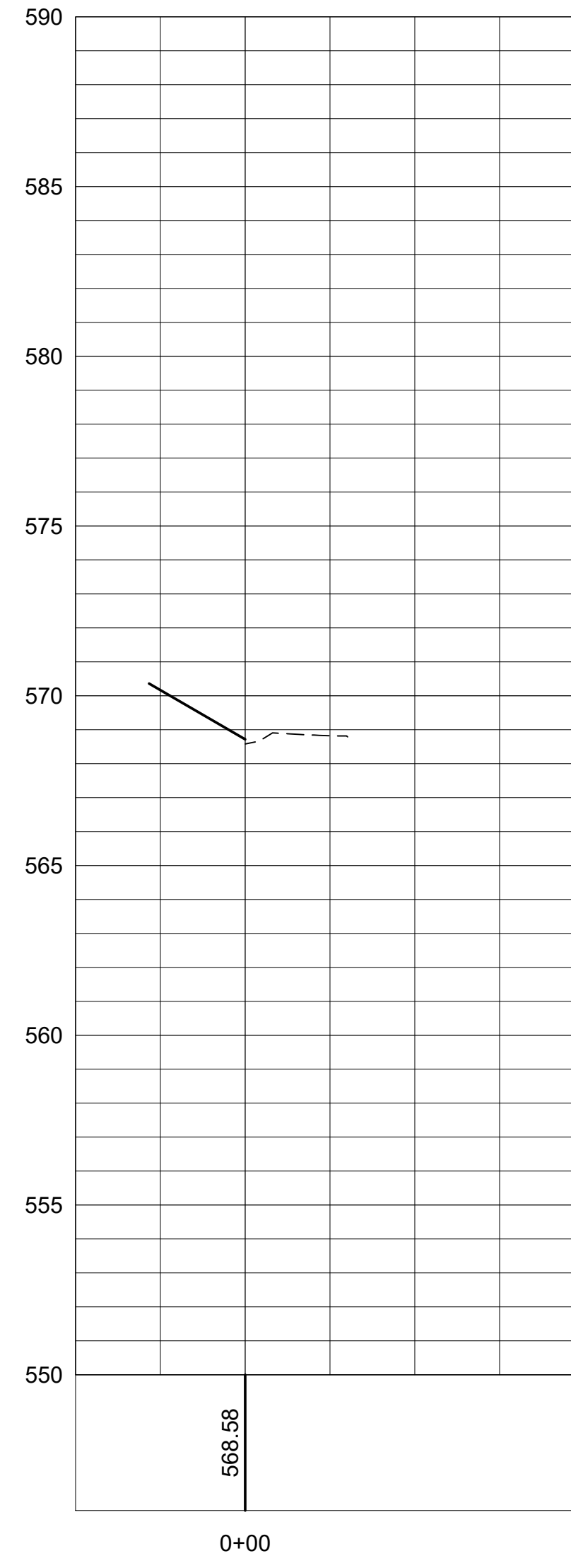

GAR C TD E PROFILE

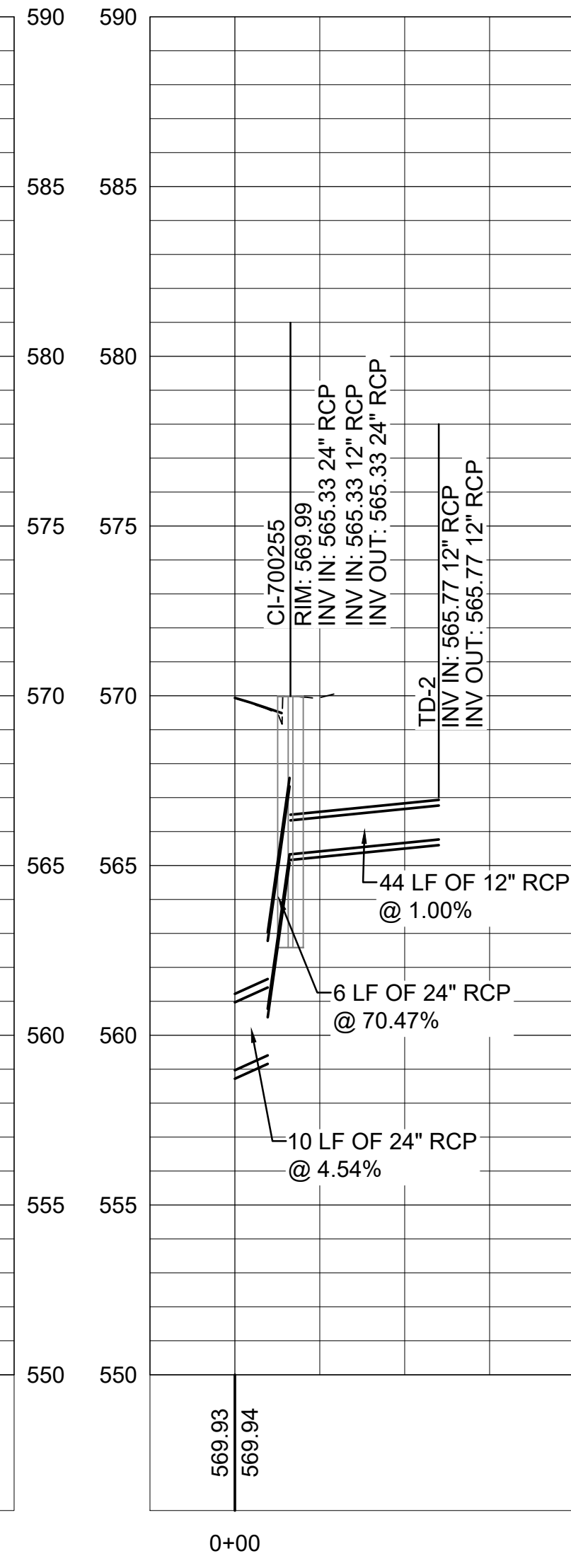

TIK3 PROFILE

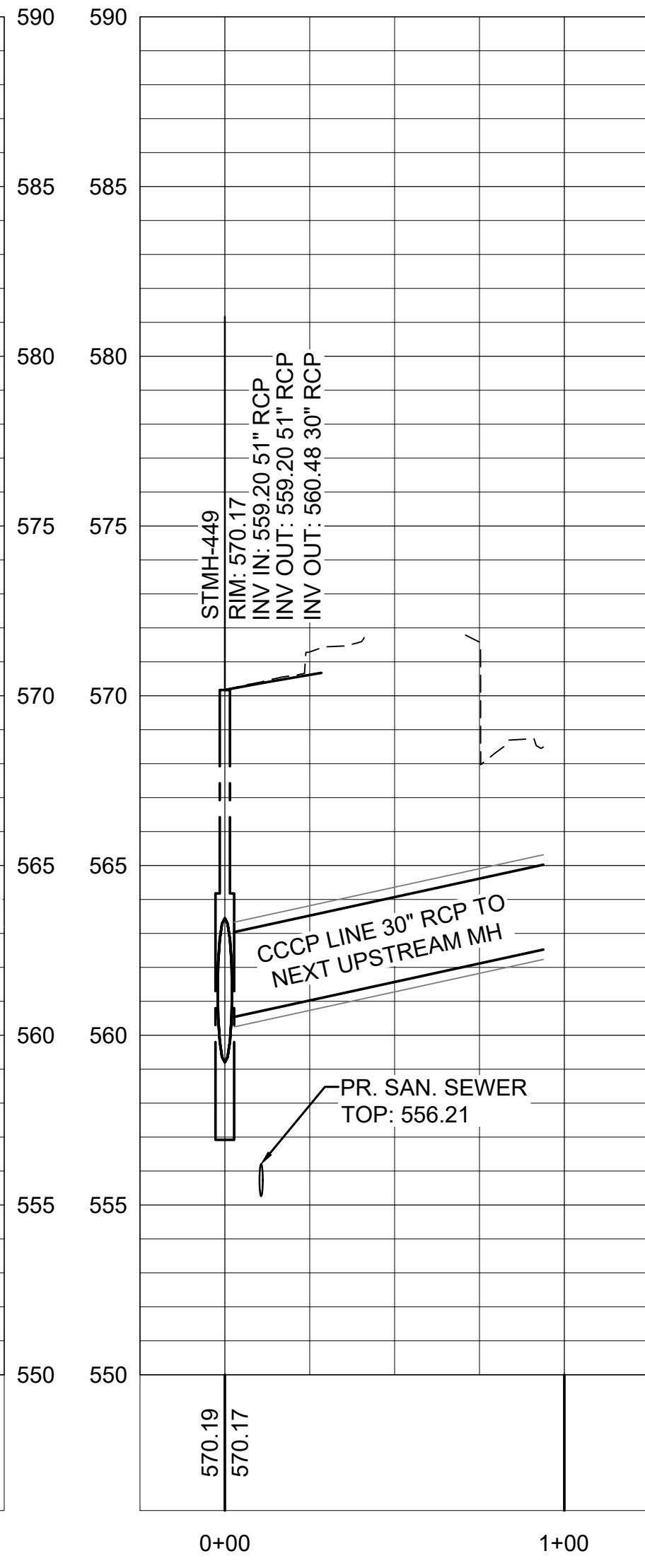

GAR C CI 3 PROFILE

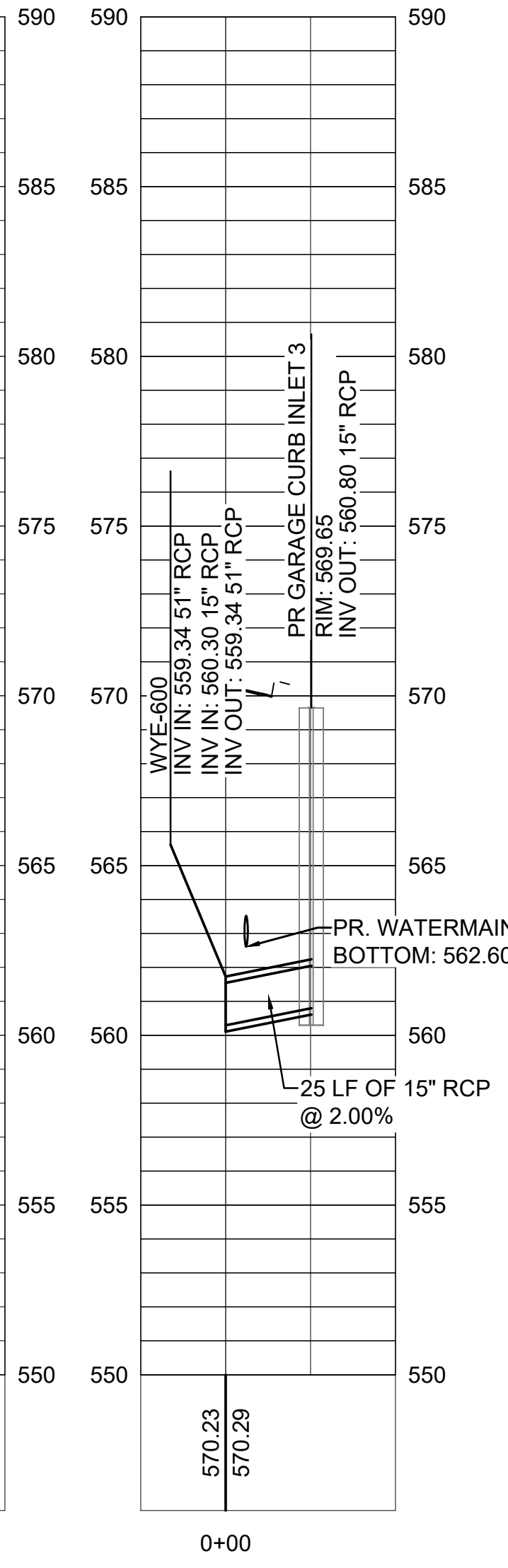

CI-30109 PROFILE

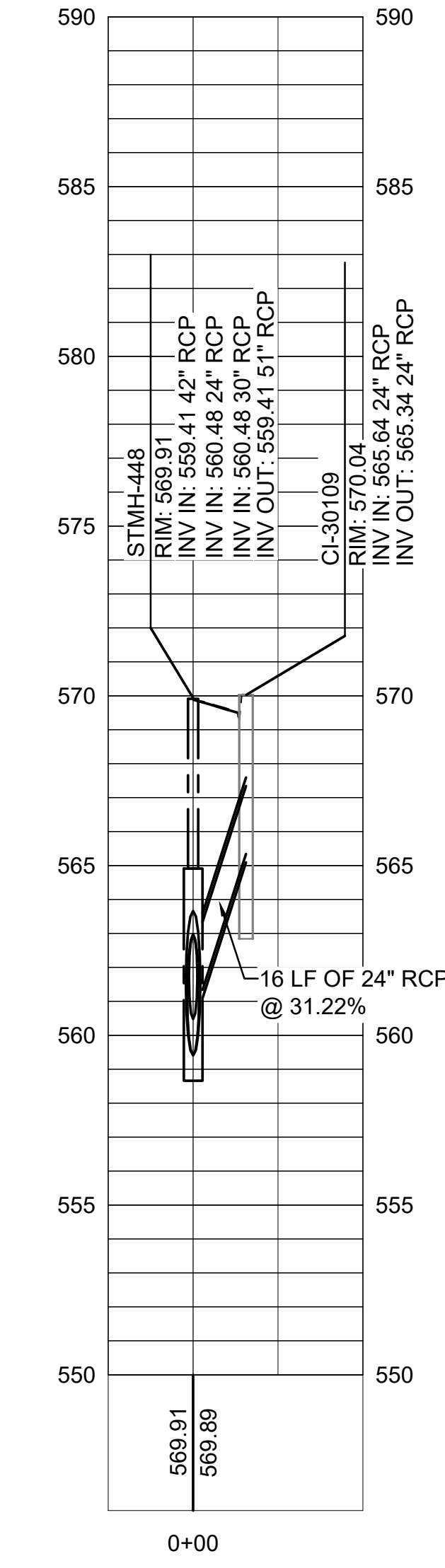

PR CI 400 PROFILE GAR CI 2 PROFILE

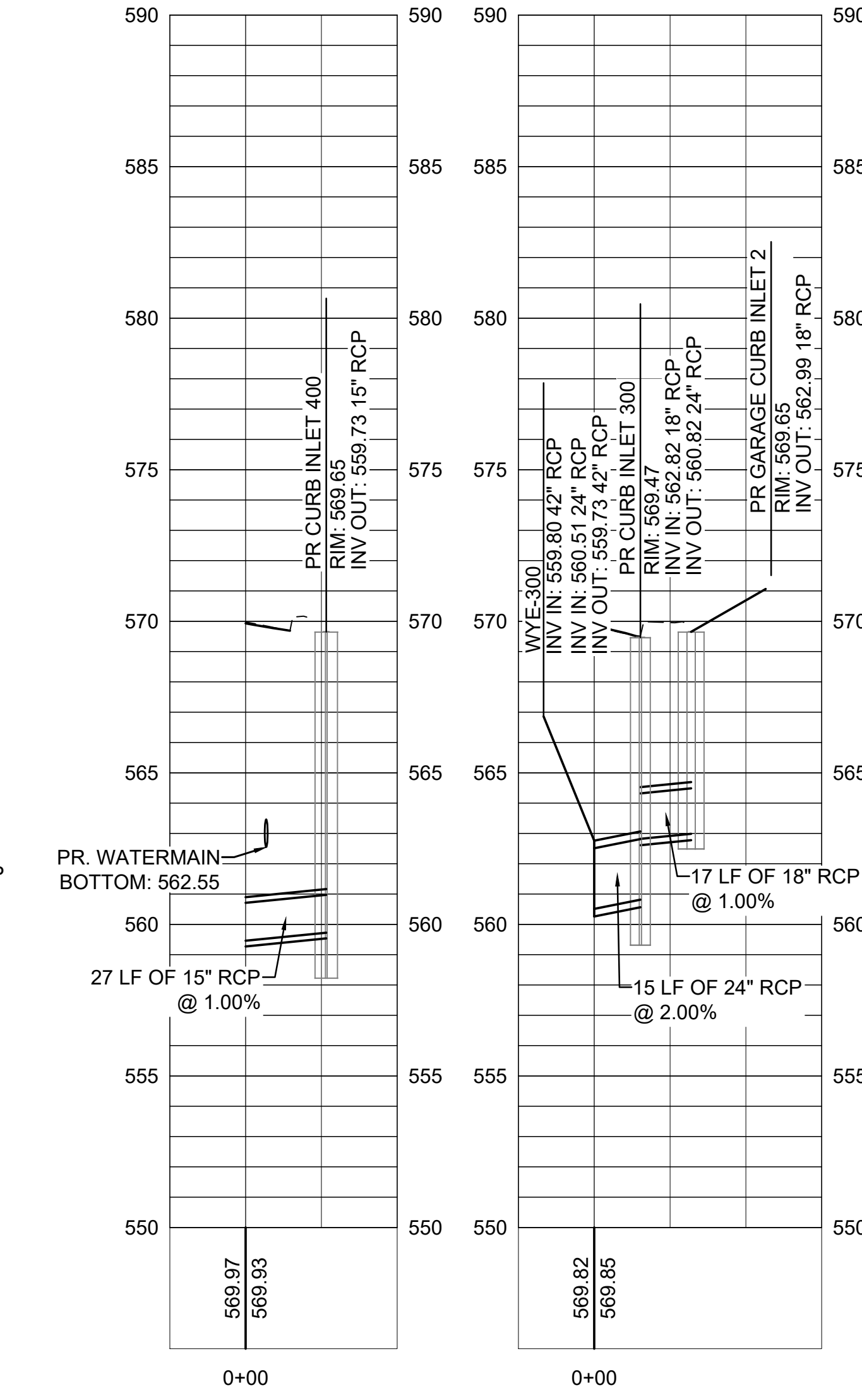

T1K W PROFILE

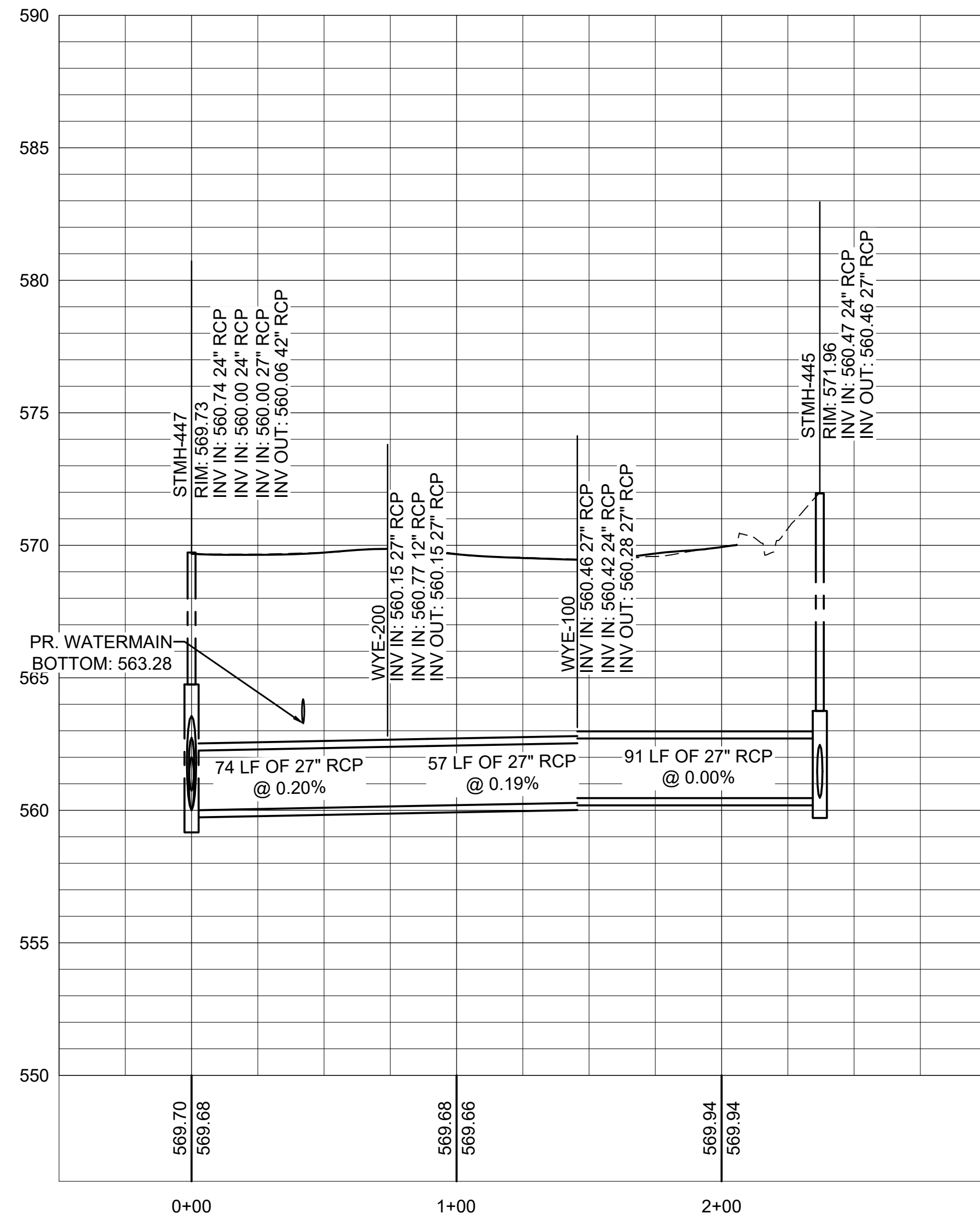

CI-30125 PROFILE

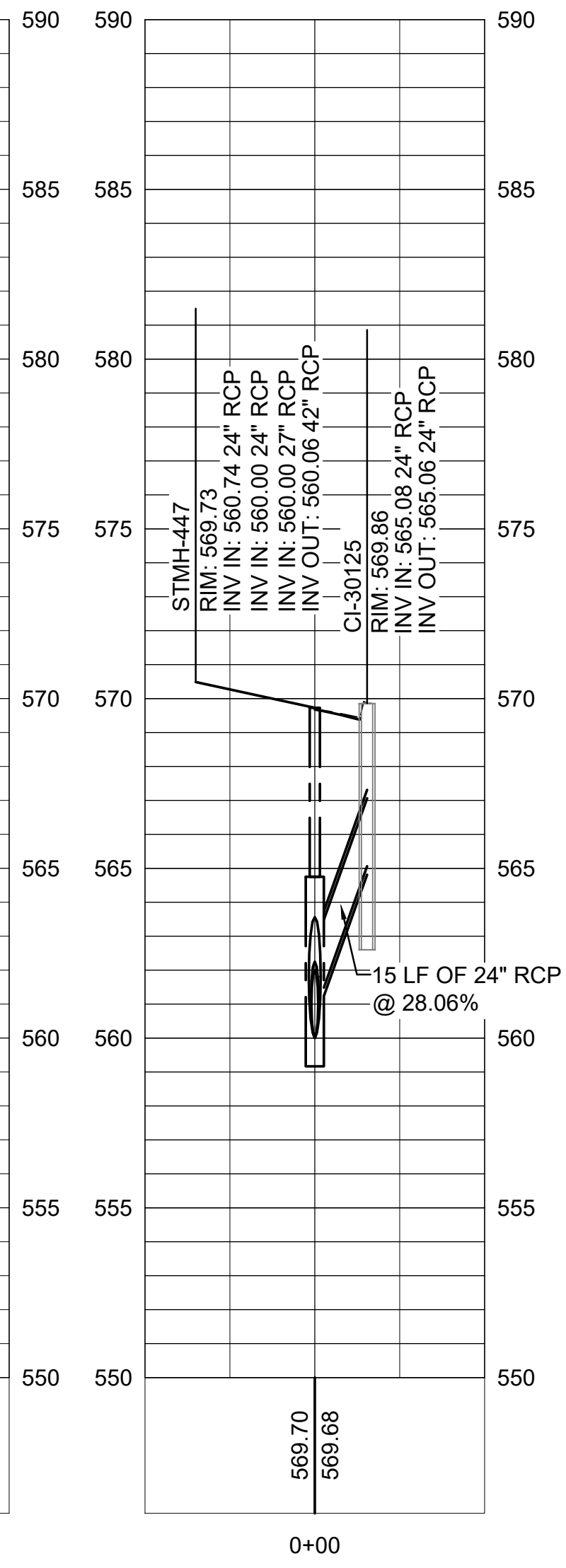

GAR CI 1 PROFILE

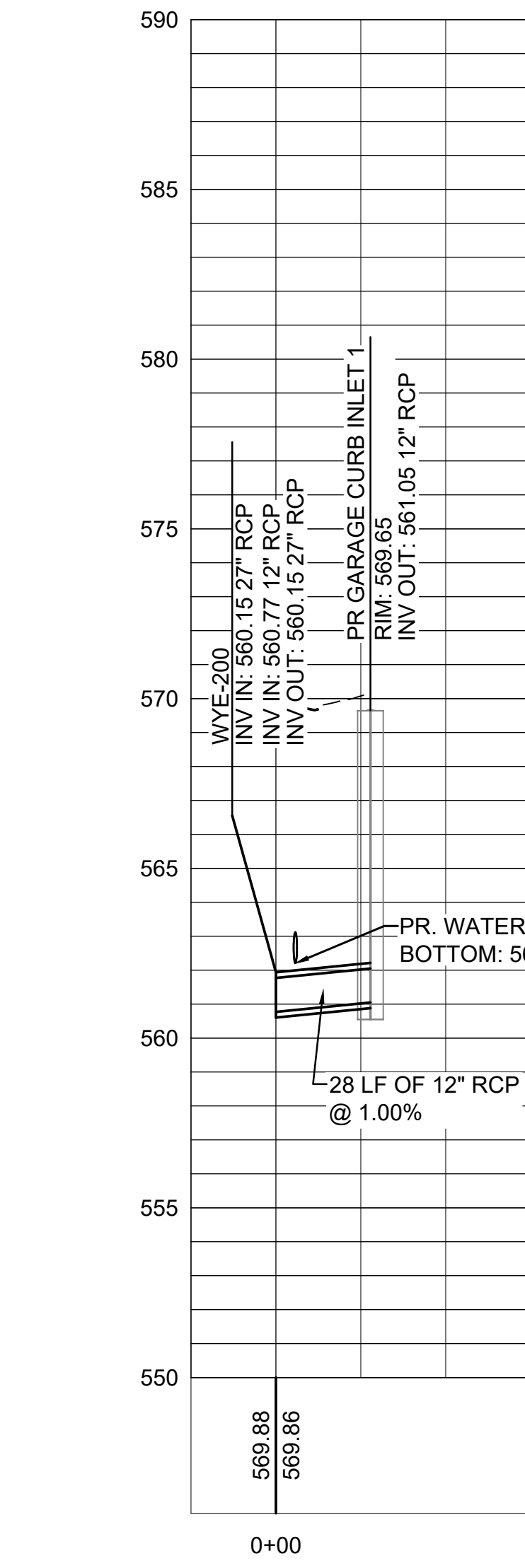

GAR C TD W PROFILE

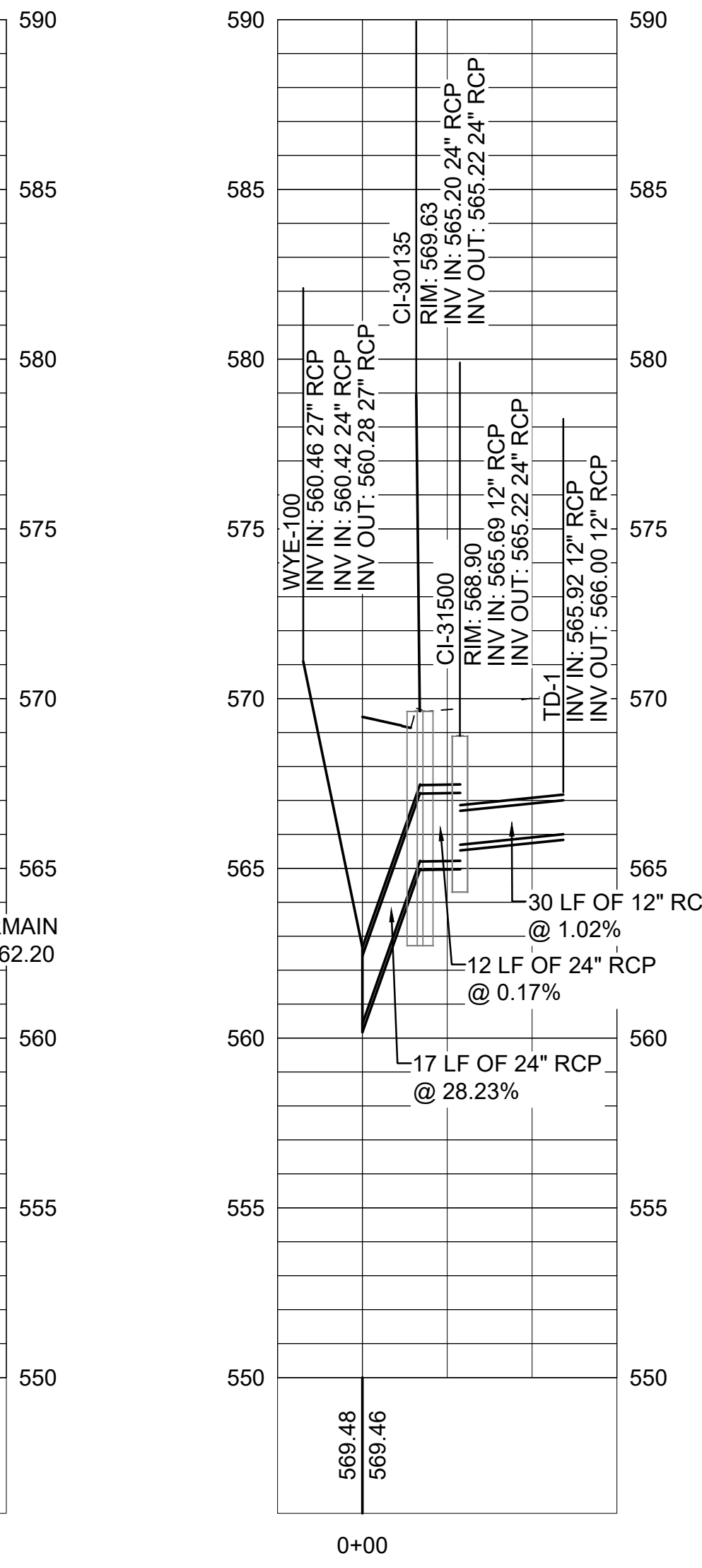

BORDER RELEASE DATE: October 16, 2021
01/20/2021 10:59:09 AM
C:\Users\jrc2020\OneDrive\Documents\CU203-900R\DWG\Terminal C Garages and Roadways\DWG\CI-30125-01-0000_StormProfile.dwg



2330 N INTERNATIONAL PARKWAY
DFW AIRPORT, TX 75261

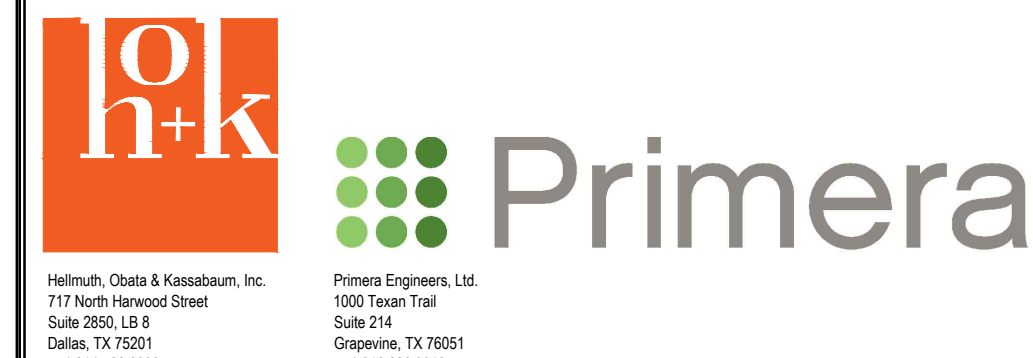

DRAWN BY: JNB
APPROVED BY: JMA
ISSUE DATE: 2022-07-28
NOT FOR BID OR CONSTRUCTION

NO.	DATE	DESCRIPTION
1	2022-01-08	30% DESIGN
2	2022-05-01	100% DESIGN
3	2022-07-28	100% SUBMITTED FOR PERMIT (SP)

PROJECT NUMBER: TFD-007

TERMINAL C GARAGE & ROADWAYS
STORM SEWER PROFILES

PERMIT NUMBER: B22-0023

SHEET NUMBER
CU203-900R

SCALE(S) AS NOTED ON THIS SHEET ARE BASED ON A FULL SIZE 30 X 42 SHEET.

SANITARY SEWER PIPE PROFILE - GARAGE A & B - STA: 100+00 TO 114+00

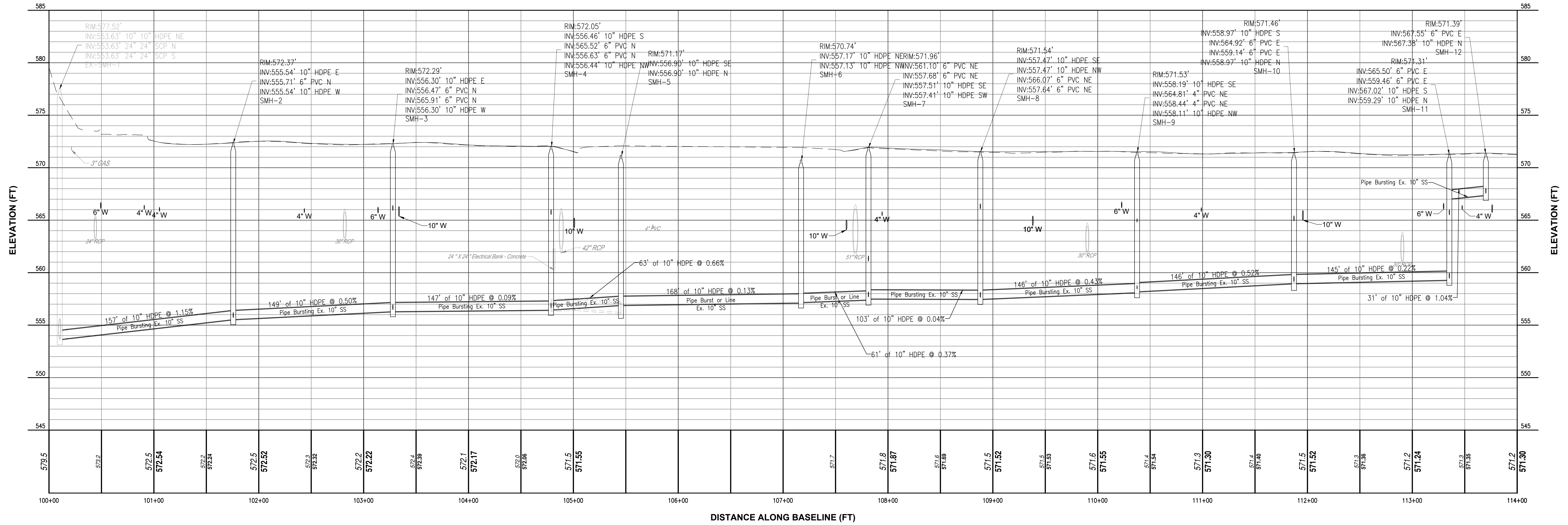

SANITARY SEWER PIPE PROFILE - GARAGE B & C - STA: 200+00 TO 214+00

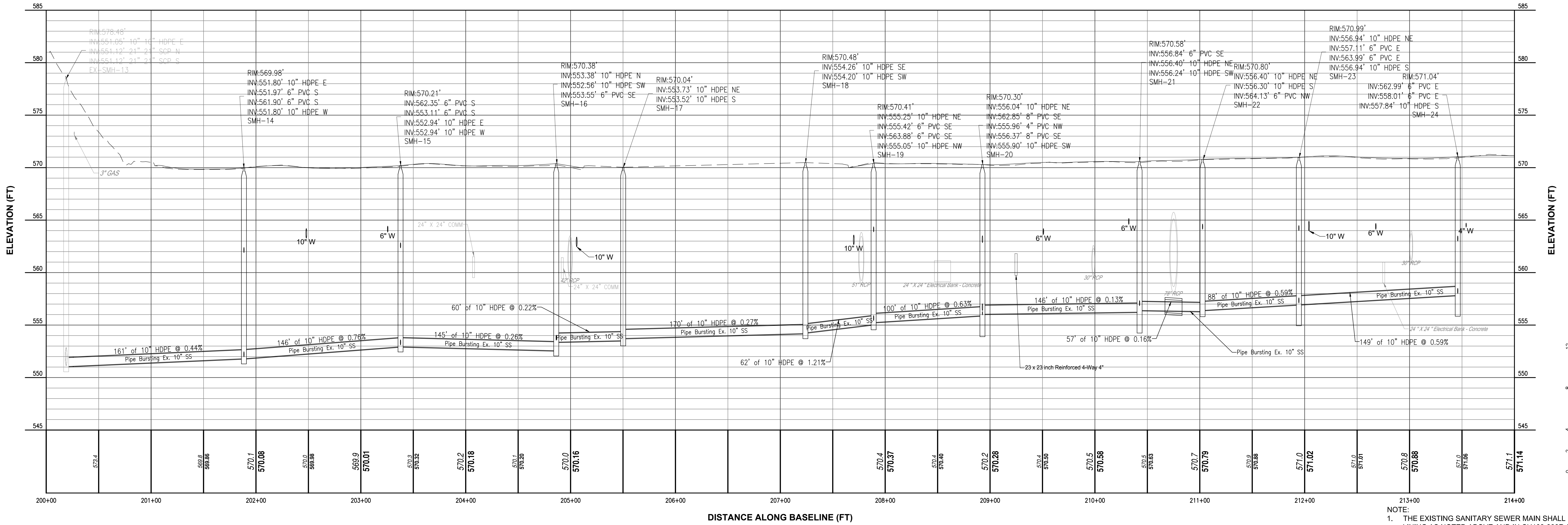

NOTE:
 1. THE EXISTING SANITARY SEWER MAIN SHALL USE PIPE BURSTING OR LINING AS NOTED ABOVE AND IN CU103-900R & CU104-900R.
 2. THE WATER LEVEL SAGS SHOWN ON THE PROFILES ARE DISTANCES FROM CCTV INSPECTIONS. THE WATER DEPTHS ARE APPROXIMATE AND WERE SCALED FROM THE VIDEO INSPECTION.

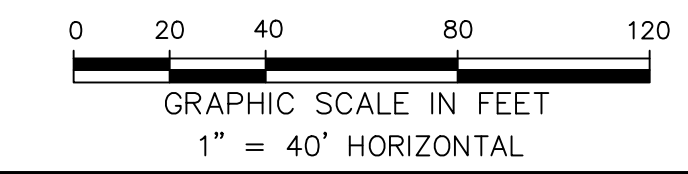

BORDER RELEASE DATE: October 16, 2021
 01/20/21 7:46:09 AM
 C:\Users\jgier\OneDrive\Documents\DFW\Terminal C Garage and Roadways\Project Files\01 CTA - Terminal C Garage and Roadways\0202-DFW-TCC-02-0200_PRR-UTL.dwg



DALLAS FORT WORTH INTERNATIONAL AIRPORT
 2330 N INTERNATIONAL PARKWAY
 DFW AIRPORT, TX 75261



DRAWN BY: KWF
 APPROVED BY: PJW
 ISSUE DATE: 2022-07-28
NOT FOR BID OR CONSTRUCTION

NO.	DATE	DESCRIPTION
001	08/13/20	30% DESIGN
002	02/21/21	30% DESIGN
003	02/21/21	100% DESIGN
004	02/21/21	100% DESIGN FOR PERMIT (PDP)

PROJECT NUMBER: TFD-007
 PERMIT NUMBER: A21-1888
 SCALE(S) AS NOTED ON THIS SHEET ARE BASED ON A FULL SIZE 30 X 42 SHEET.

SHEET NUMBER
 CU204-900R

WATER PIPE PROFILE - GARAGE B & C - STA: 300+00 TO 313+00

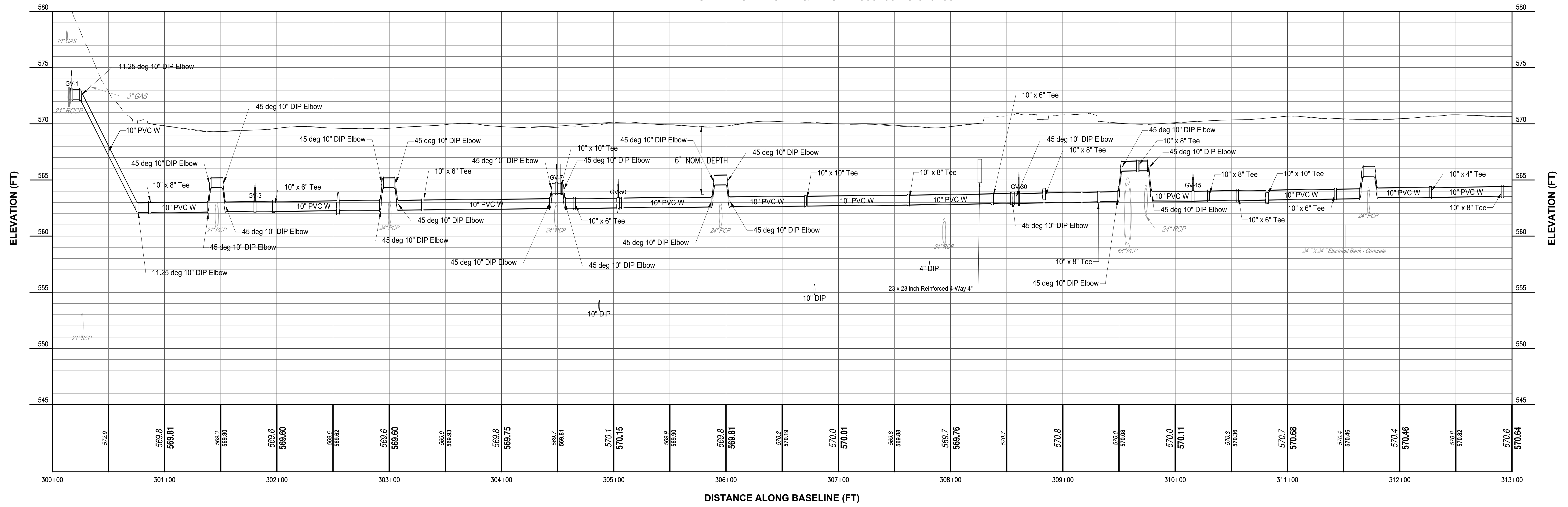

WATER PIPE PROFILE - GARAGE A & B - STA: 313+00 TO 326+50

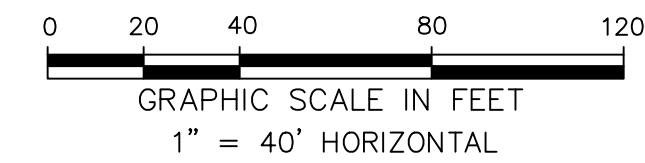
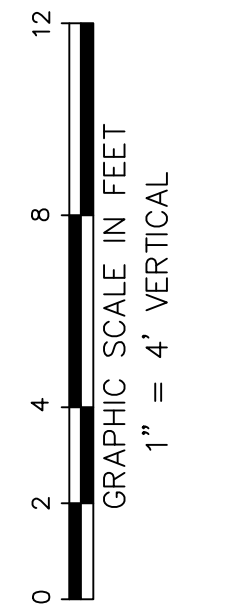
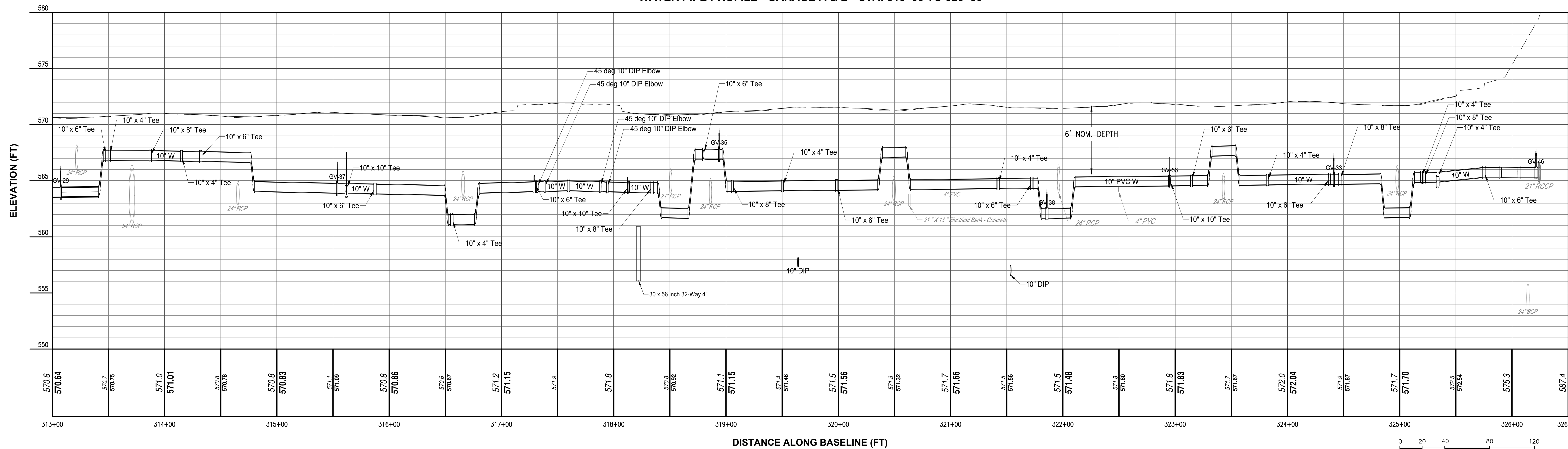

BORDER RELEASE DATE: October 16, 2021
 01/20/2021 7:46:09 AM
 C:\Users\jgier\OneDrive\Documents\HOK\DAL\DFW\Terminal C\Expansion Programs\Project Files\01_CTA - Terminal C Garages and Roadways\05_GE01 - CAD\Sheets\020202-DFW\TC-CU205-9000_PRR\UTL.dwg



DALLAS
 FORT WORTH
 INTERNATIONAL
 AIRPORT



DRAWN BY: KWF
 APPROVED BY: PJW
 ISSUE DATE: 2022-07-28
**NOT FOR BID OR
 CONSTRUCTION**

NO.	DATE	DESCRIPTION
001	08/11/20	30% DESIGN
002	02/21/21	50% DESIGN
003	02/21/21	100% DESIGN
004	02/21/21	100% DESIGN FOR PERMIT (PDP)

PROJECT NUMBER: TFD-007

TERMINAL C GARAGE & ROADWAYS
WATER PIPE PROFILES 1

SHEET NUMBER
CU205-900R

PERMIT NUMBER: A21-1888

SCALE(S) AS NOTED ON THIS SHEET ARE BASED ON A FULL SIZE 30 X 42 SHEET.

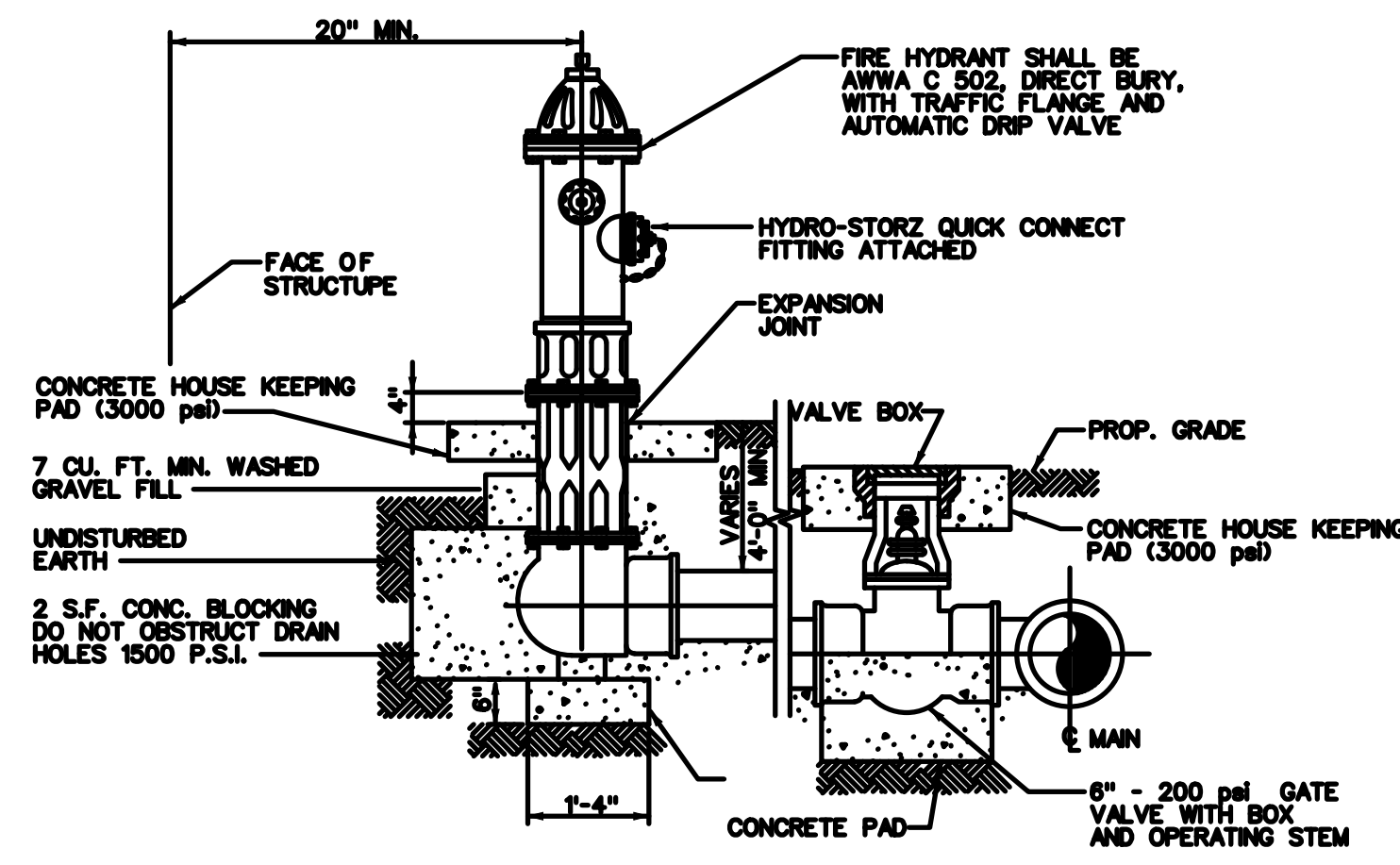

FIRE HYDRANT INSTALLATION DETAIL
NOT TO SCALE

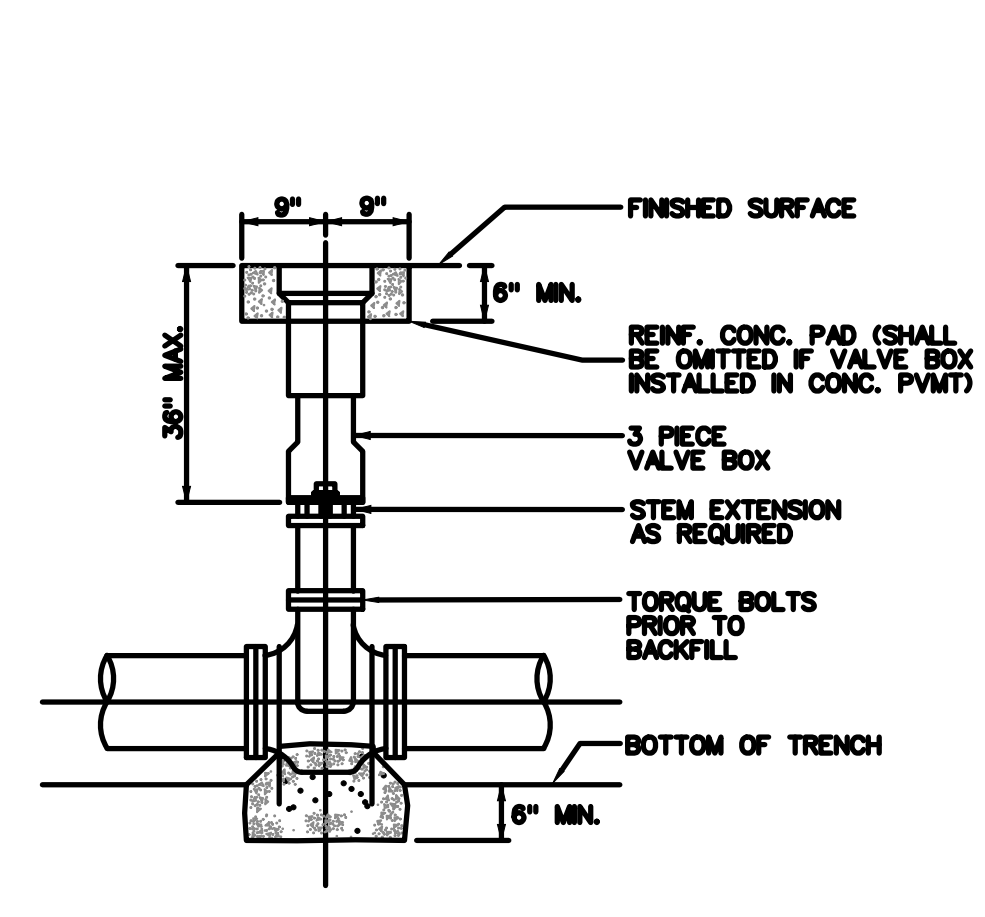

GATE VALVE AND BOX
NOT TO SCALE

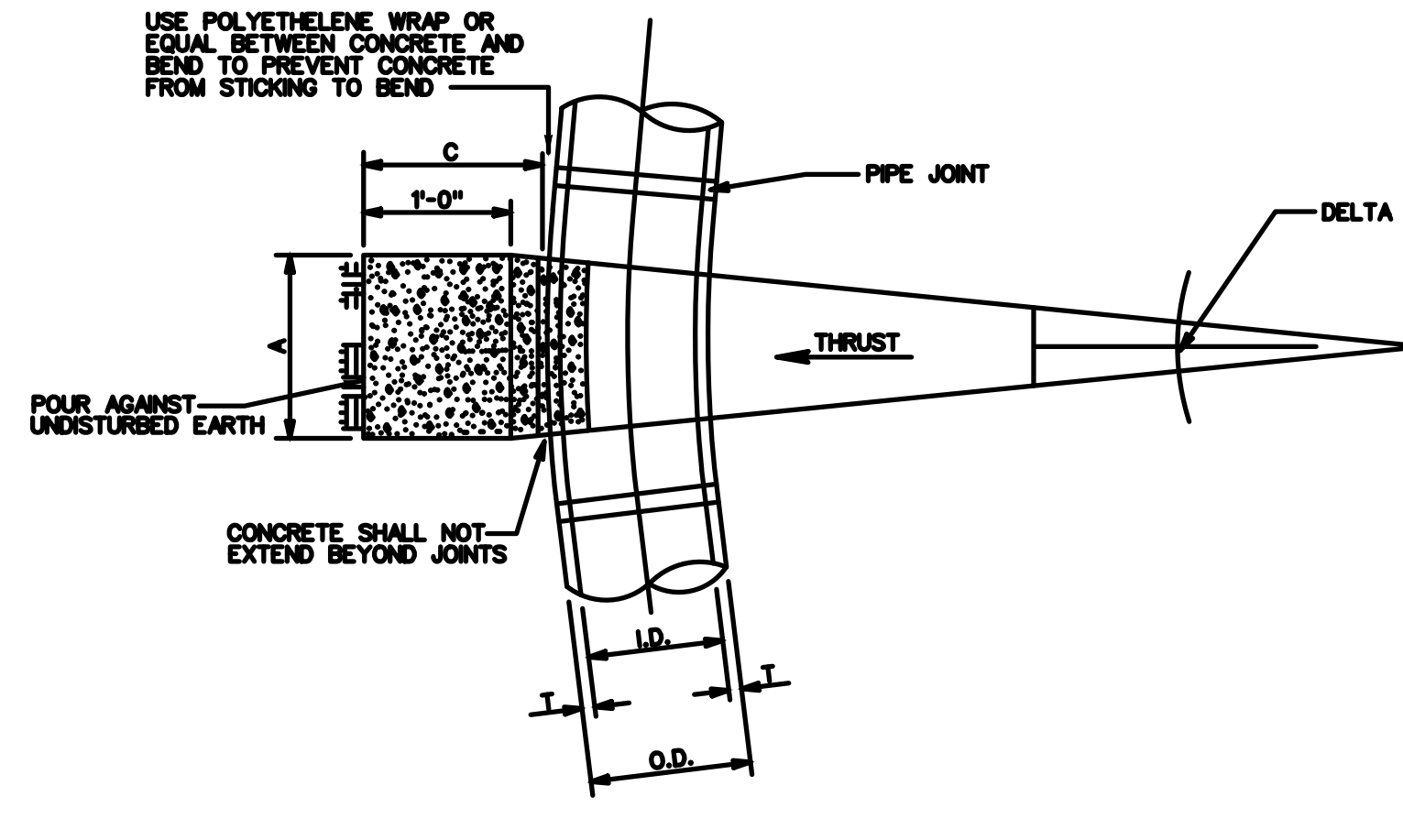

THRUST BLOCKING
NOT TO SCALE

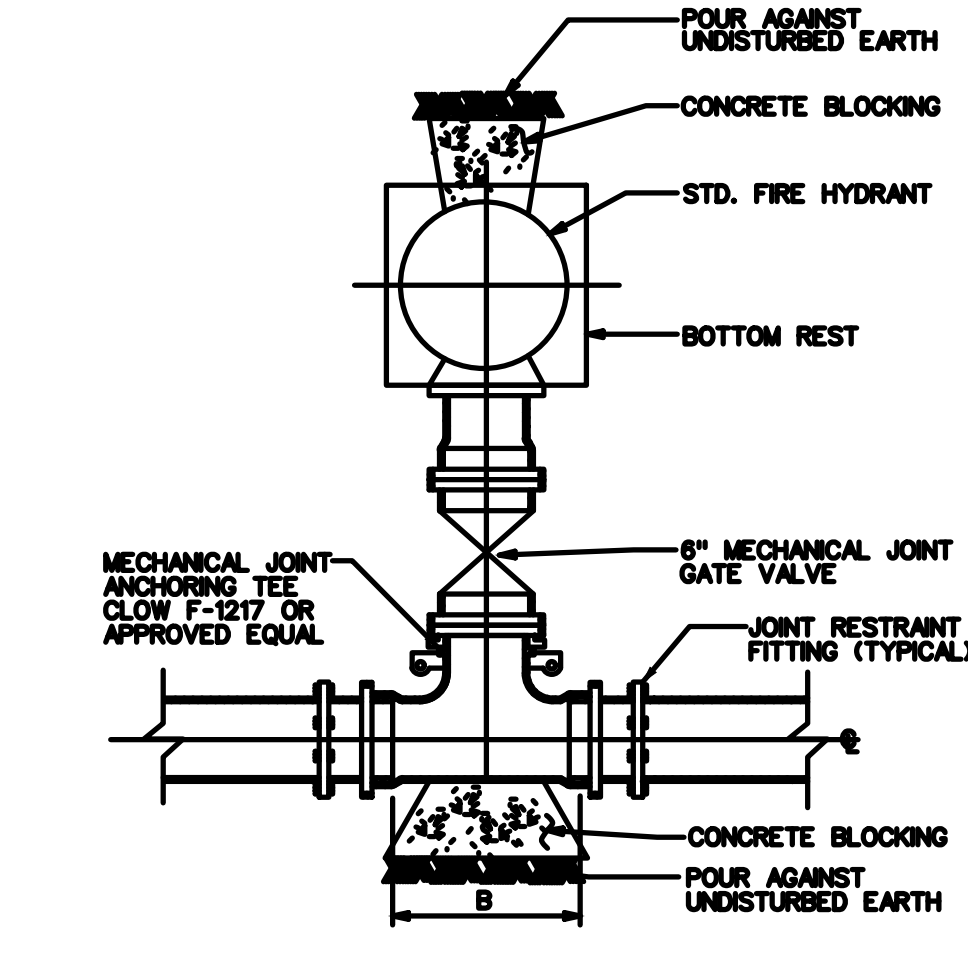

FIRE HYDRANT THRUST BLOCK
NOT TO SCALE

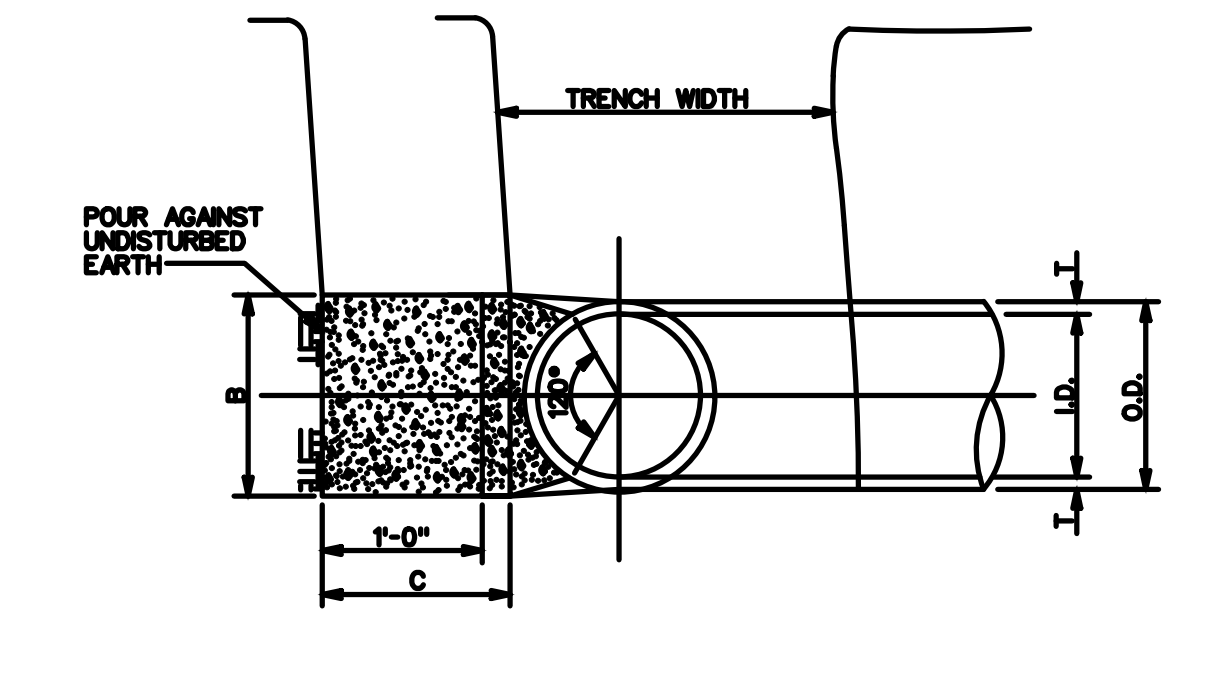

THRUST BLOCKING - SECTION
NOT TO SCALE

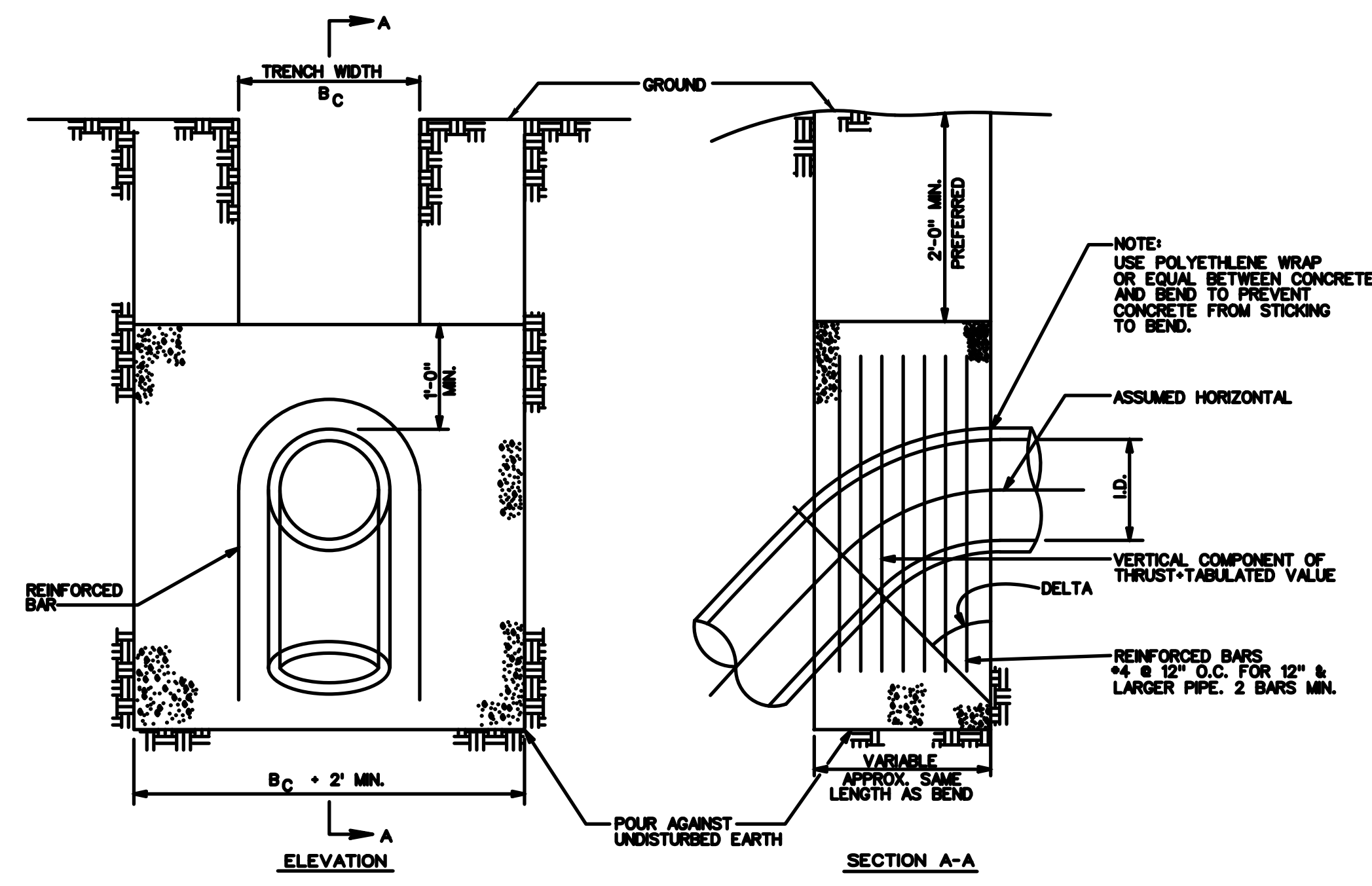

THRUST BLOCKING DETAIL
NOT TO SCALE

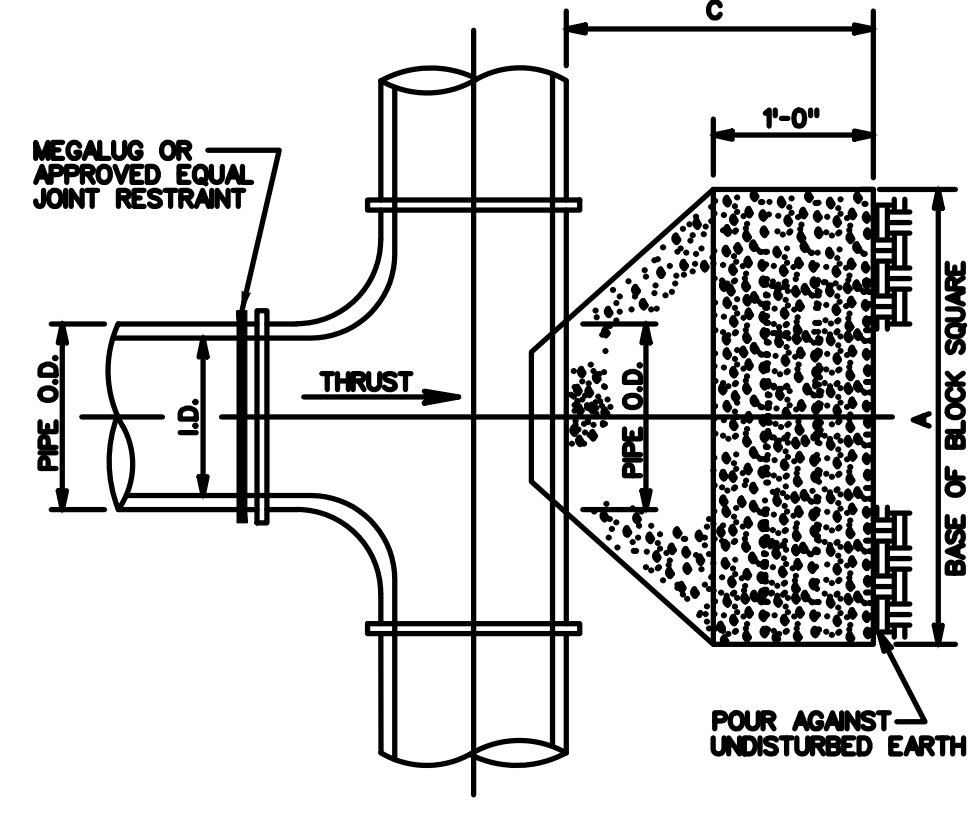

TEE THRUST BLOCK - PLAN
NOT TO SCALE

HORIZONTAL BEND THRUST BLOCK																		
		$\Delta = 11.25^\circ$				$\Delta = 22.50^\circ$				$\Delta = 45^\circ$				$\Delta = 90^\circ$				
I.D. (IN.)	C FT.	E FT.	G FT.	A FT.	B FT.	VOL. C.Y.	G FT.	A FT.	B FT.	VOL. C.Y.	G FT.	A FT.	B FT.	VOL. C.Y.	G FT.	A FT.	B FT.	VOL. C.Y.
6,8	1.5	0.9	0.4	1.0	1.5	0.1	0.8	1.5	1.5	0.1	1.5	2.0	2.0	0.2	2.7	5.0	1.5	0.4
10,12	1.5	1.2	0.6	1.5	1.5	0.1	1.1	2.0	2.5	0.3	2.2	3.5	2.5	0.5	4.0	6.5	2.5	1.0
16,18	1.5	1.6	0.8	2.0	2.5	0.3	1.6	3.0	3.5	0.6	3.2	4.5	4.5	1.2	6.0	9.0	4.0	2.4
20	1.5	1.8	0.9	2.0	3.5	0.4	1.8	3.5	3.5	0.7	3.6	5.5	4.5	1.5	6.6	10.0	4.5	3.1
24	1.5	2.1	1.1	3.0	3.5	0.5	2.2	4.0	4.5	1.0	4.3	8.0	4.5	2.3	7.8	14.5	4.5	5.0
30	1.9	2.6	1.4	3.0	3.5	0.6	2.7	5.0	4.5	1.5	5.4	8.5	5.0	3.2	9.9	15.0	5.0	6.7

HORIZONTAL BEND THRUST BLOCK
NOT TO SCALE

PLUG & TEE THRUST BLOCK			
I.D. (IN.)	C FT.	A FT.	VOL. C.Y.
6,8	1.5	2.5	0.3
10,12	1.5	3.5	0.6
16,18	2.0	5.5	1.6
20	2.0	6.0	1.9
24	2.5	7.0	3.1
30	3.0	7.5	4.1

PLUG AND TEE THRUST BLOCK
NOT TO SCALE

BORDER RELEASE DATE: October 16, 2021
01/20/2021 7:46:09 AM C:\Users\jgier\OneDrive\Documents\HOK\DALDFW\Infl Airport - CTA Expansion Program\Project Files\01 CTA - Terminal C Garages and Roadways\05 CE01 - CAD\Sheets\050302.DWG\TCC-15-0100_Details.dwg



DALLAS FORT WORTH INTERNATIONAL AIRPORT
2330 N INTERNATIONAL PARKWAY
DFW AIRPORT, TX 75261



DRAWN BY: KWF
APPROVED BY: PJW
ISSUE DATE: 2022-07-28
NOT FOR BID OR CONSTRUCTION

NO.	DATE	DESCRIPTION
0001-01-20	07/28/22	50% DESIGN
0002-01-20	07/28/22	50% DESIGN
0003-01-20	07/28/22	100% DESIGN
0004-01-20	07/28/22	100% DESIGN FOR PERMIT (PDP)

PROJECT NUMBER: TFD-007

TERMINAL C GARAGE & ROADWAYS
WATER DETAILS 1

PERMIT NUMBER: A21-1888

SHEET NUMBER
CU501-900R

SCALE(S) AS NOTED ON THIS SHEET ARE BASED ON A FULL SIZE 30 X 42 SHEET.

STRUCTURE TABLE									
STRUCTURE NAME	TYPE	NORTHING	EASTING	TOP OF CASTING	PIPE DIRECTION	INV. EL. (FT)	DIA. (IN)	REMARKS	
EX-SMH-1	Existing Wastewater Structure	7014342.21	2417197.53	577.52	NE N S	553.63 553.63 553.63	10 24 24		
EX-SMH-13	Existing Wastewater Structure	7012901.15	2417212.36	578.48	E N S	551.05 551.12 551.12	10 21 21		
SMH-2	TYPE A-1 MANHOLE WITH TYPE P STACK	7014346.53	2417362.89	572.37	E W N	555.54 555.54 555.71	10 10 6		
SMH-3	TYPE A-1 MANHOLE WITH TYPE P STACK	7014337.74	2417514.55	572.29	E W N N	556.30 556.30 556.47 565.91	10 10 6 6		
SMH-4	TYPE A-1 MANHOLE WITH TYPE P STACK	7014295.78	2417659.12	572.05	S NW N N	556.46 556.44 565.52 566.63	10 10 6 6		
SMH-5	TYPE A-1 MANHOLE WITH TYPE P STACK	7014232.24	2417639.10	571.17	SE N	556.90 556.90	10 10		
SMH-6	TYPE A-1 MANHOLE WITH TYPE P STACK	7014150.39	2417790.12	570.74	NE NW	557.17 557.13	10 10		
SMH-7	TYPE A-1 MANHOLE WITH TYPE P STACK	7014199.62	2417831.40	571.96	SE SW NE NE	557.51 557.41 561.10 557.68	10 10 6 6		
SMH-8	TYPE A-1 MANHOLE WITH TYPE P STACK	7014130.78	2417912.72	571.54	SE NW NE NE	557.47 557.47 568.07 557.64	10 10 6 6		
SMH-10	TYPE A-1 MANHOLE WITH TYPE P STACK	7013881.39	2418074.00	571.46	S N E E	558.97 558.97 564.92 559.14	10 10 6 6		
SMH-11	TYPE A-1 MANHOLE WITH TYPE P STACK	7013738.22	2418110.83	571.31	E N E S	565.50 559.29 559.46 567.02	10 6 6 10		
SMH-12	TYPE A-1 MANHOLE WITH TYPE P STACK	7013703.94	2418116.95	571.39	N E	567.38 567.55	10 6		
SMH-14	TYPE A-1 MANHOLE WITH TYPE P STACK	7012898.23	2417381.86	569.98	E W S S	551.80 551.80 551.97 561.90	10 10 6 6		
SMH-15	TYPE A-1 MANHOLE WITH TYPE P STACK	7012911.63	2417530.43	570.21	E W S S	552.94 552.94 562.35 553.11	10 10 6 6		
SMH-16	TYPE A-1 MANHOLE WITH TYPE P STACK	7012955.20	2417672.05	570.38	N SW SE	553.38 552.56 553.50	10 10 6		
SMH-17	TYPE A-1 MANHOLE WITH TYPE P STACK	7013015.56	2417651.33	570.04	NE S	553.73 553.52	10 10		
SMH-18	TYPE A-1 MANHOLE WITH TYPE P STACK	7013105.20	2417800.20	570.48	SE SW	554.26 554.20	10 10		
SMH-19	TYPE A-1 MANHOLE WITH TYPE P STACK	7013056.13	2417842.93	570.41	NE NW SE SE	555.25 555.05 555.42 563.88	10 10 6 6		
SMH-20	TYPE A-1 MANHOLE WITH TYPE P STACK	7013125.45	2417919.92	570.30	NE SW SE NW SE	556.04 555.90 562.85 555.96 556.37	10 8 8 4 8		
SMH-21	TYPE A-1 MANHOLE WITH TYPE P STACK	7013242.10	2418013.77	570.58	NE SW SE	556.40 556.24 556.84	10 10 6		
SMH-22	TYPE A-1 MANHOLE WITH TYPE P STACK	7013291.74	2418047.52	570.80	NE S NW	556.40 556.30 564.13	10 10 6		
SMH-23	TYPE A-1 MANHOLE WITH TYPE P STACK	7013377.41	2418080.27	570.99	NE S E E	556.94 556.94 557.11 563.99	10 10 6 6		
SMH-24	TYPE A-1 MANHOLE WITH TYPE P STACK	7013525.45	2418111.69	571.04	E S E	562.99 557.84 558.01	6 10 6		

WATER LATERAL POINTS OF CONNECTION				
Fitting Name	SIZE	NORTHING	EASTING	PIPE CENTER ELEVATION
C-002	6" PVC	7014351.95	2417236.55	566.75
C-003	4" PVC	7014359.69	2417278.08	567.00
C-004	4" PVC	7014359.67	2417292.63	566.85
C-008	4" PVC	7014359.04	2417431.22	566.39
C-010	6" PVC	7014352.22	2417502.37	566.21
C-013	10" PVC	7014349.92	2417522.57	566.10
C-017	4" PVC	7014306.17	2417677.40	566.31
C-018	6" PVC	7014235.04	2417811.13	566.02
C-020	6" PVC	7014202.38	2417850.03	565.67
C-024	10" PVC	7014107.24	2417964.67	565.60
C-028	6" PVC	7014039.53	2418016.93	565.83
C-032	4" PVC	7013967.07	2418049.32	565.44
C-036	10" PVC	7013877.51	2418088.17	565.78
C-039	6" PVC	7013746.04	2418125.08	565.59
C-040A	4" PVC	7013728.54	2418128.73	565.40
C-040C	6" PVC	7013699.67	2418133.27	565.24
C-041A	4" PVC	7013661.35	2418133.98	565.25
C-041B	6" PVC	7013599.89	2418134.35	565.75
C-042	4" PVC	7013631.49	2418128.10	565.12
C-045	6" PVC	7013445.34	2418113.38	564.90
C-047	10" PVC	7013382.29	2418095.48	564.90
C-054	6" PVC	7013221.47	2418026.65	565.22
C-056	6" PVC	7013153.51	2417977.66	564.75
C-059	10" PVC	7013042.18	2417842.60	564.16
C-060	6" PVC	7012949.60	2417699.19	564.50
C-063	6" PVC	7012897.19	2417520.47	564.04
C-064	10" PVC	7012888.66	2417441.99	563.74

Appurtenance Table			
Appurtenance Name	Appurtenance Description	NORTHING	EASTING
FH-1	Hydrant 72" Bury Depth	7012933.99	2417382.77
FH-2	Hydrant 72" Bury Depth	7012978.60	2417640.16
FH-3	Hydrant 72" Bury Depth	7013132.51	2417886.27
FH-4	Hydrant 72" Bury Depth	7013372.86	2418043.20
FH-5	Hydrant 72" Bury Depth	7013656.35	2418089.71
FH-6	Hydrant 72" Bury Depth	7013885.77	2418038.16
FH-7	Hydrant 72" Bury Depth	7014122.79	2417876.25
FH-8	Hydrant 72" Bury Depth	7014273.59	2417632.13
FH-9	Hydrant 72" Bury Depth	7014313.87	2417374.29
GV-1	10" Gate Valve	7012922.81	2417202.82
GV-3	10" Gate Valve	7012920.56	2417366.16
GV-4	6" Gate Valve	7012923.45	2417382.82
GV-5	6" Gate Valve	7014278.79	2417633.93
GV-6	10" Gate Valve	7012963.49	2417632.46
GV-7	10" Gate Valve	7012960.08	2417630.12
GV-8	6" Gate Valve	7012967.96	2417644.28
GV-9	6" Gate Valve	7012979.06	2417686.19
GV-10	10" Gate Valve	7013063.56	2417826.10
GV-11	6" Gate Valve	7013127.70	2417891.10
GV-12	8" Gate Valve	7013221.40	2417965.99
GV-13	8" Gate Valve	7013261.44	2417993.56
GV-14	8" Gate Valve	7013291.16	2418010.68
GV-15	10" Gate Valve	7013333.02	2418036.49
GV-16	8" Gate Valve	7013347.29	2418038.46
GV-17	6" Gate Valve	7013370.62	2418049.03

Appurtenance Table			
Appurtenance Name	Appurtenance Description	NORTHING	EASTING
GV-18	10" Gate Valve	7013393.39	2418063.58
GV-19	6" Gate Valve	7013452.30	2418080.31
GV-20	4" Gate Valve	7013535.46	2418095.59
GV-21	6" Gate Valve	7013656.61	2418094.90
GV-22	4" Gate Valve	7013659.18	2418100.20
GV-23	8" Gate Valve	7013695.74	2418096.84
GV-24	4" Gate Valve	7013733.26	2418093.54
GV-25	6" Gate Valve	7013740.73	2418092.57
GV-26	10" Gate Valve	7013866.49	2418058.19
GV-27	4" Gate Valve	7013952.58	2418019.81
GV-28	10" Gate Valve	7014082.15	2417930.47
GV-29	10" Gate Valve	7013615.89	2418098.17
GV-30	10" Gate Valve	7013202.08	2417954.78
GV-31	8" Gate Valve	7014144.13	2417860.79
GV-32	6" Gate Valve	7014127.28	2417880.36
GV-33	10" Gate Valve	7014322.45	2417370.55
GV-34	4" Gate Valve	7014177.64	2417830.76
GV-35	10" Gate Valve	7014139.12	2417872.52
GV-36	4" Gate Valve	7014274.08	2417664.31
GV-37	10" Gate Valve	7013857.48	2418057.62
GV-38	10" Gate Valve	7014285.69	2417622.11
GV-39	6" Gate Valve	7014318.06	2417497.50
GV-40	4" Gate Valve	7014324.35	2417429.67
GV-41	8" Gate Valve	7014317.41	2417365.22
GV-42	6" Gate Valve	7014205.54	2417791.27

Appurtenance Table			
Appurtenance Name	Appurtenance Description	NORTHING	EASTING
GV-43	4" Gate Valve	7014325.38	2417292.63
GV-44	8" Gate Valve	7014317.84	2417289.84
GV-45	4" Gate Valve	7014325.38	2417278.08
GV-46	6" Gate Valve	7012920.52	2417516.53
GV-46	10" Gate Valve	7014319.16	2417190.56
GV-47	10" Gate Valve	7012912.47	2417440.56
GV-48	6" Gate Valve	7013887.87	2418043.28
GV-49	6" Gate Valve	7014320.15	2417374.29
GV-50	10" Gate Valve	7012980.22	2417681.26
GV-51	6" Gate Valve	7013178.95	2417946.10
GV-52	8" Gate Valve	7013599.84	2418104.64
GV-53	6" Gate Valve	7014015.93	2417982.12
GV-54	8" Gate Valve	7014095.86	2417913.18
GV-55	6" Gate Valve	7014031.32	2417951.23
GV-56	10" Gate Valve	7014314.63	2417516.52
GV-57	6" Gate Valve	7014325.71	2417236.83

FITTING TABLES				
Name	FITTING	NORTHING	EASTING	PIPE CENTER ELEVATION
CR-1	6" x 3" DIP MJ Cross	N 7014022.01	E 2417938.30	567.00
E-1	11.25 deg 10" DIP Elbow	N 7012922.77	E 2417210.55	572.60
E-2	11.25 deg 10" DIP Elbow	N 7012920.40	E 2417261.25	562.52
E-3	45 deg 10" DIP Elbow	N 7014065.88	E 2417939.79	564.45
E-4	45 deg 10" DIP Elbow	N 7014056.60	E 2417938.39	564.47
E-5	45 deg 10" DIP Elbow	N 7014017.32	E 2417967.34	564.48
E-6	45 deg 10" DIP Elbow	N 7014015.84	E 2417977.23	564.46
E-7	45 deg 10" DIP Elbow	N 7012920.57	E 2417324.44	562.58
E-8	45 deg 10" DIP Elbow	N 7013474.21	E 2418082.79	563.77
E-9	45 deg 10" DIP Elbow	N 7012925.04	E 2417477.64	562.74
E-10	45 deg 10" DIP Elbow	N 7012958.29	E 2417625.02	562.89
E-11	45 deg 10" DIP Elbow	N 7013018.53	E 2417755.56	563.03
E-12	45 deg 10" DIP Elbow	N 7013274.64	E 2418005.28	563.52
E-13	45 deg 10" DIP Elbow	N 7012920.57	E 2417326.44	564.74
E-14	45 deg 10" DIP Elbow	N 7013476.17	E 2418083.18	565.74
E-15	45 deg 10" DIP Elbow	N 7012925.29	E 2417479.62	564.74
E-16	45 deg 10" DIP Elbow	N 7012958.82	E 2417626.53	564.24
E-17	45 deg 10" DIP Elbow	N 7013019.57	E 2417757.26	564.99
E-18	45 deg 10" DIP Elbow	N 7013276.62	E 2418006.65	566.23
E-19	45 deg 10" DIP Elbow	N 7012920.57	E 2417337.52	564.75
E-20	45 deg 10" DIP Elbow	N 7013487.03	E 2418085.38	565.75
E-21	45 deg 10" DIP Elbow	N 7012926.66	E 2417490.62	564.75
E-22	45 deg 10" DIP Elbow	N 7012962.03	E 2417635.75	564.25
E-23	45 deg 10" DIP Elbow	N 7013025.33	E 2417766.73	565.00
E-24	45 deg 10" DIP Elbow	N 7013297.20	E 2418019.10	566.25
E-25	45 deg 10" DIP Elbow	N 7012920.57	E 2417339.52	562.60
E-26	45 deg 10" DIP Elbow	N 7013488.99	E 2418085.78	563.85
E-27	45 deg 10" DIP Elbow	N 7012926.91	E 2417492.61	562.75
E-28	45 deg 10" DIP Elbow	N 7012962.47	E 2417636.95	562.90
E-29	45 deg 10" DIP Elbow	N 7013026.37	E 2417768.44	563.05
E-30	45 deg 10" DIP Elbow	N 7013299.52	E 2418020.31	563.57

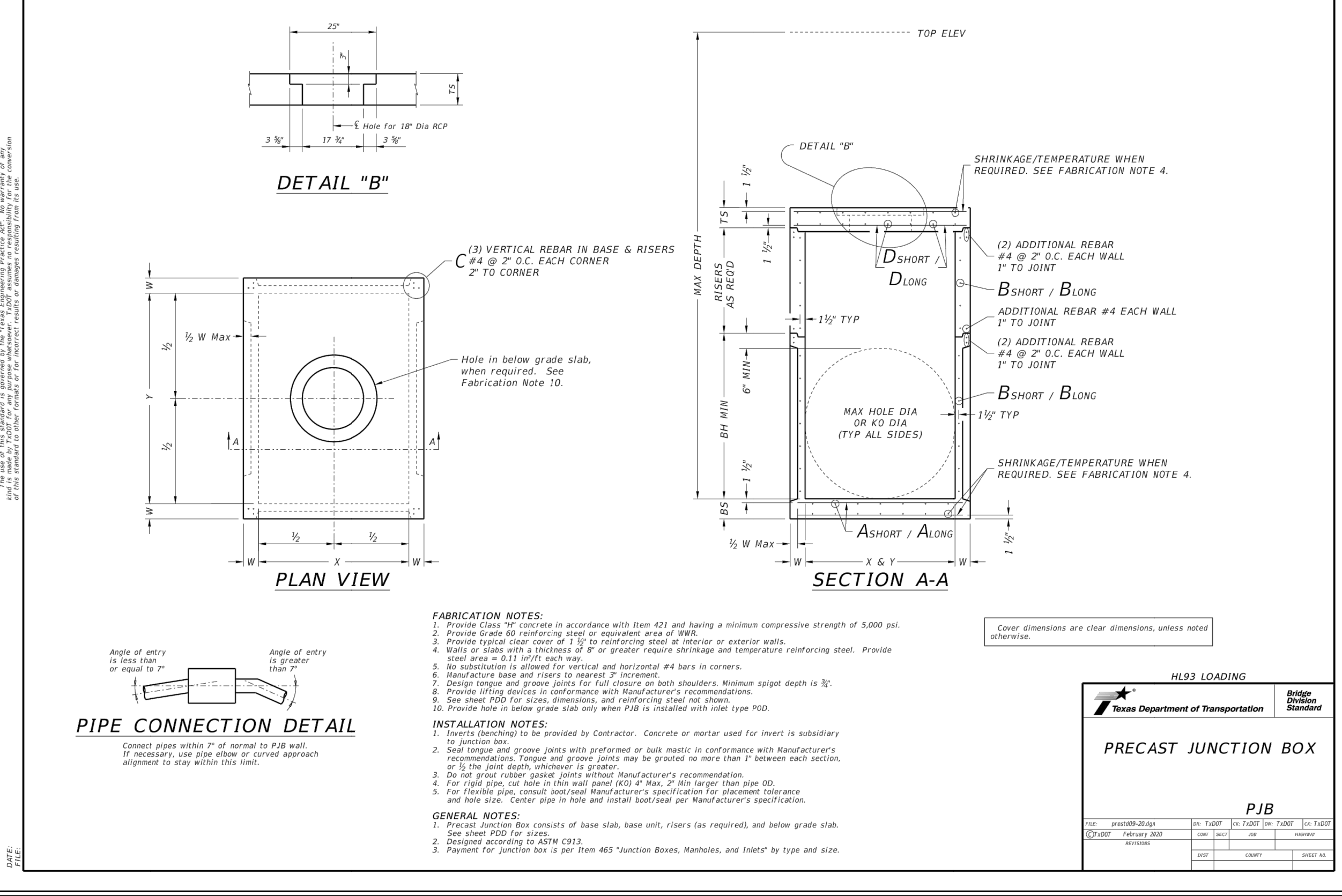
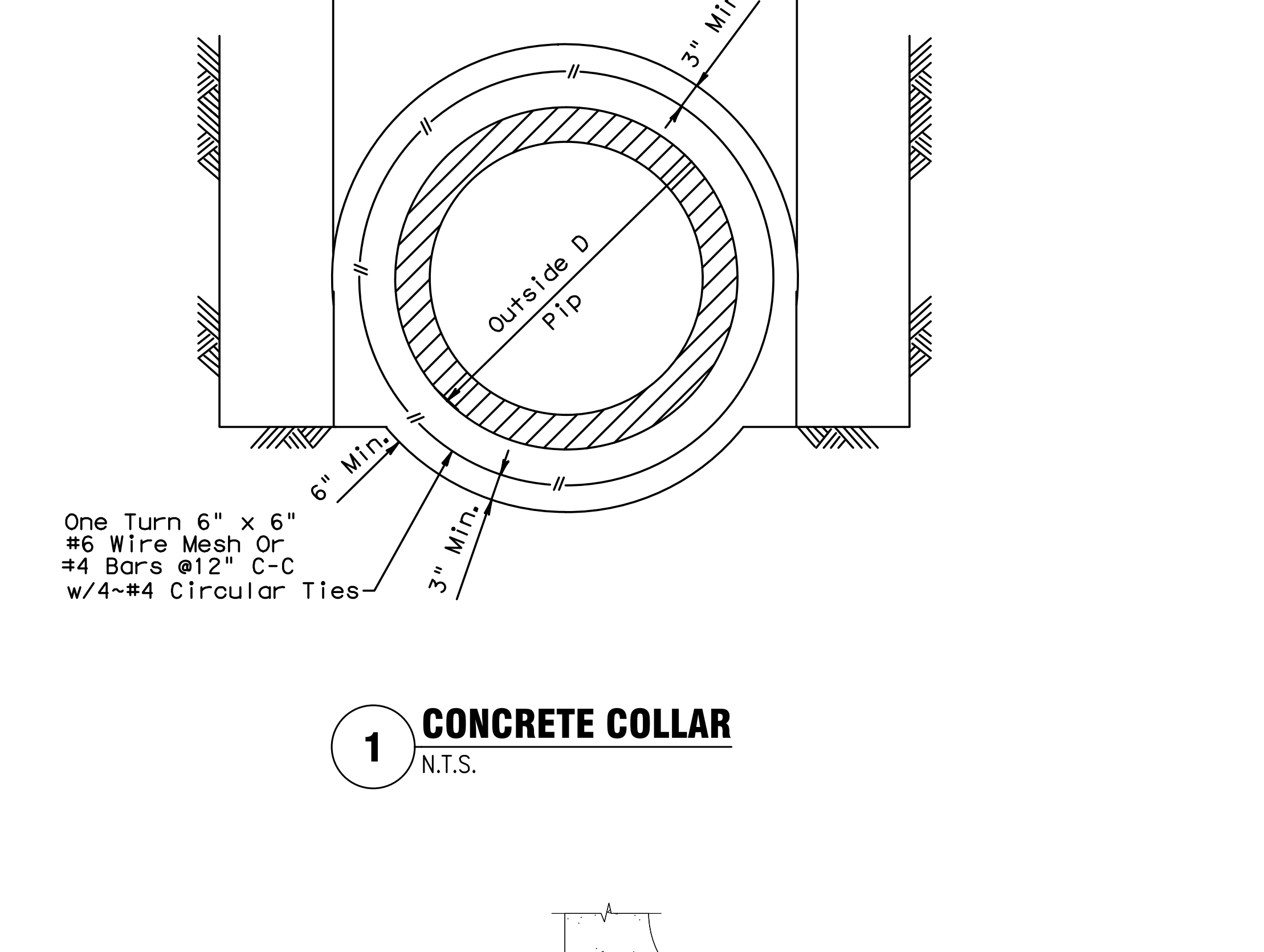
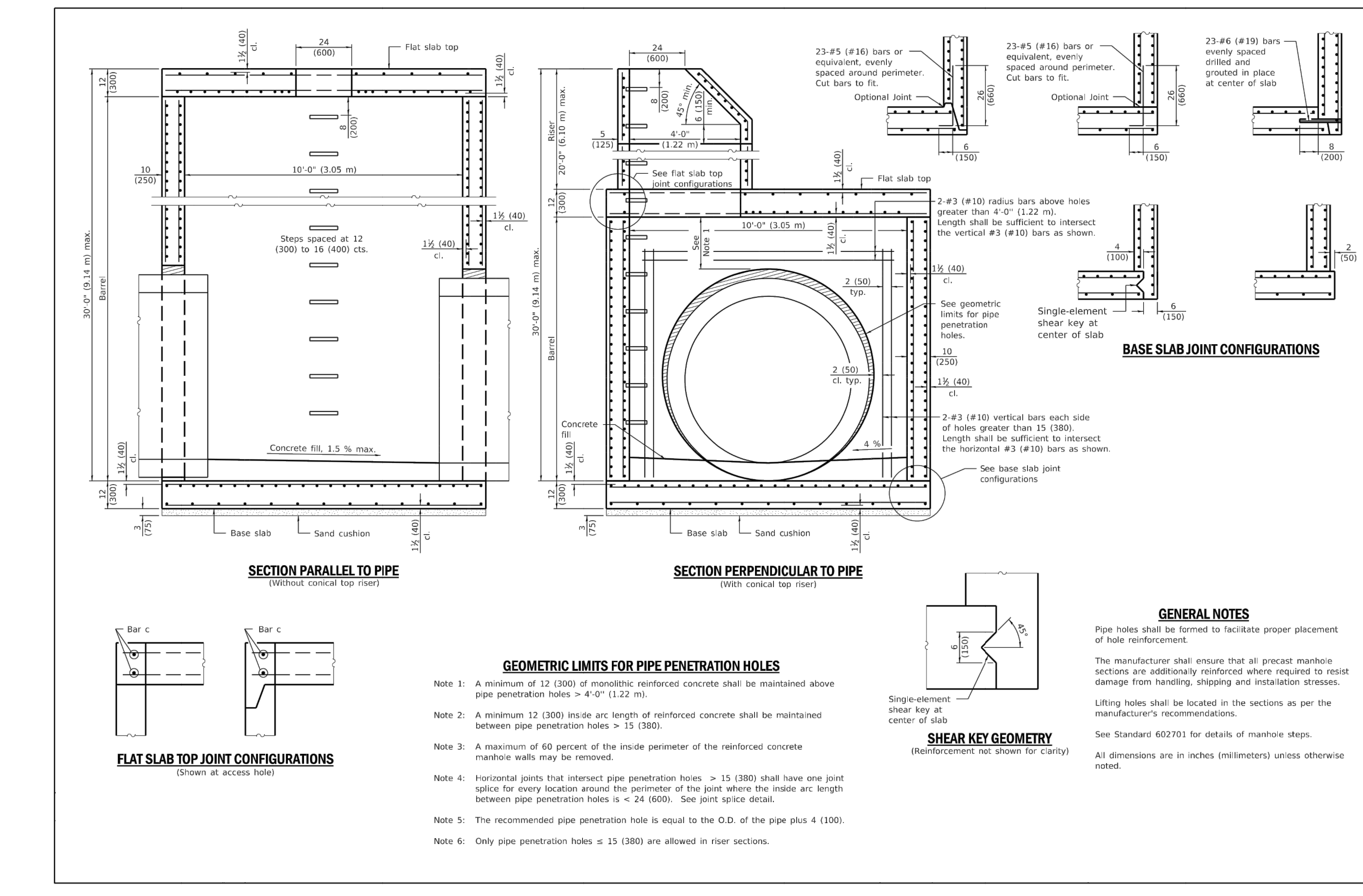
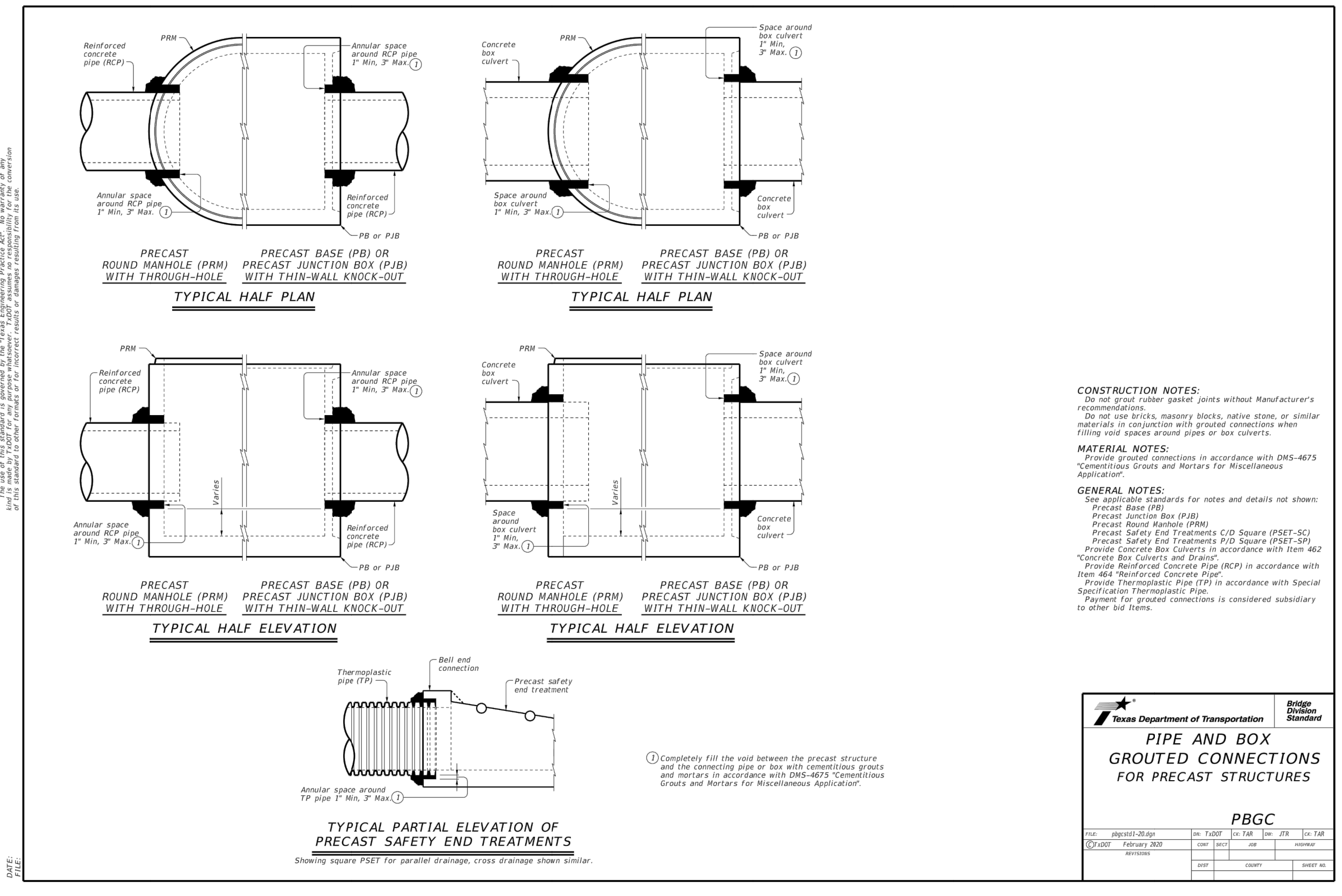
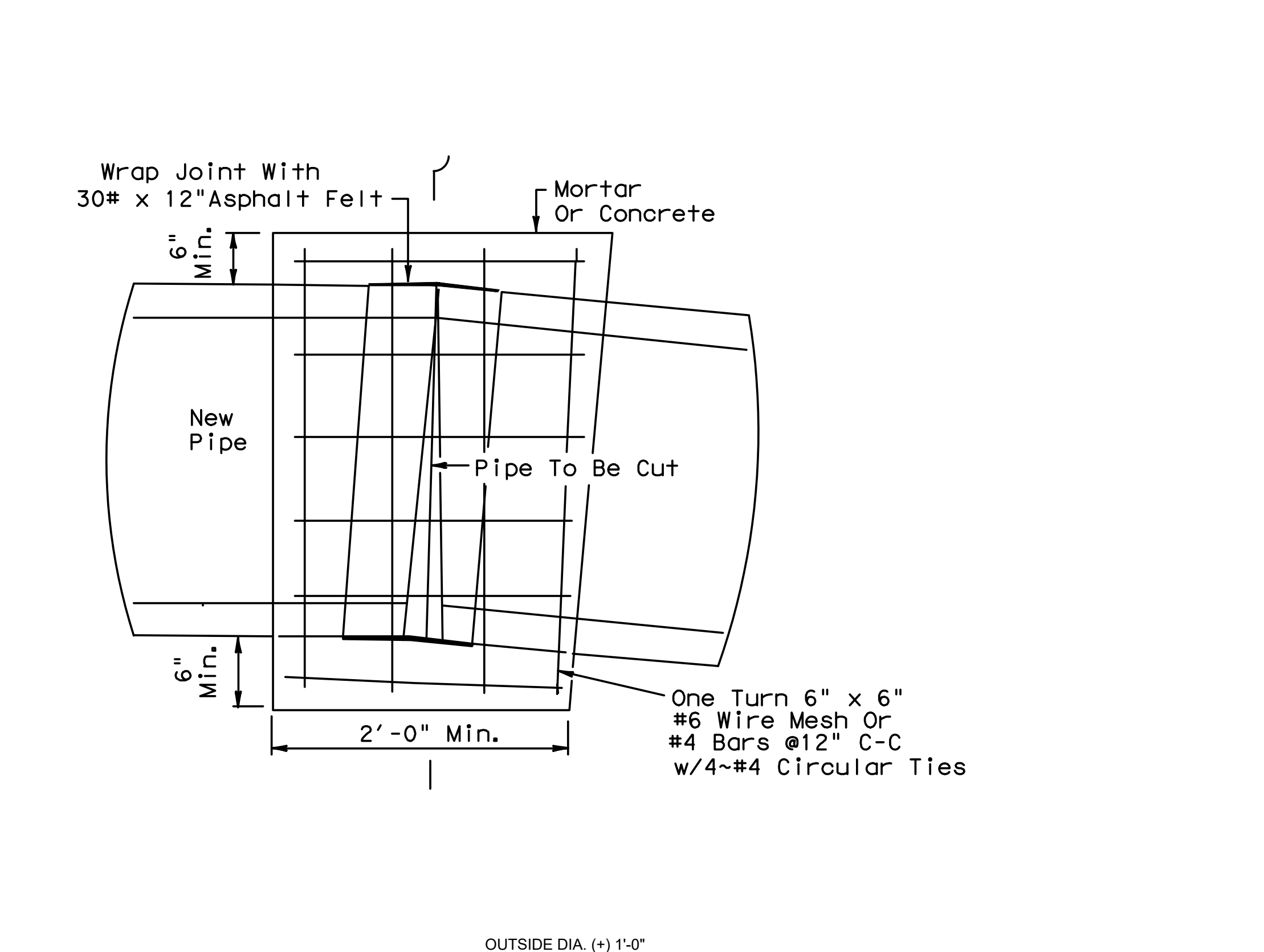
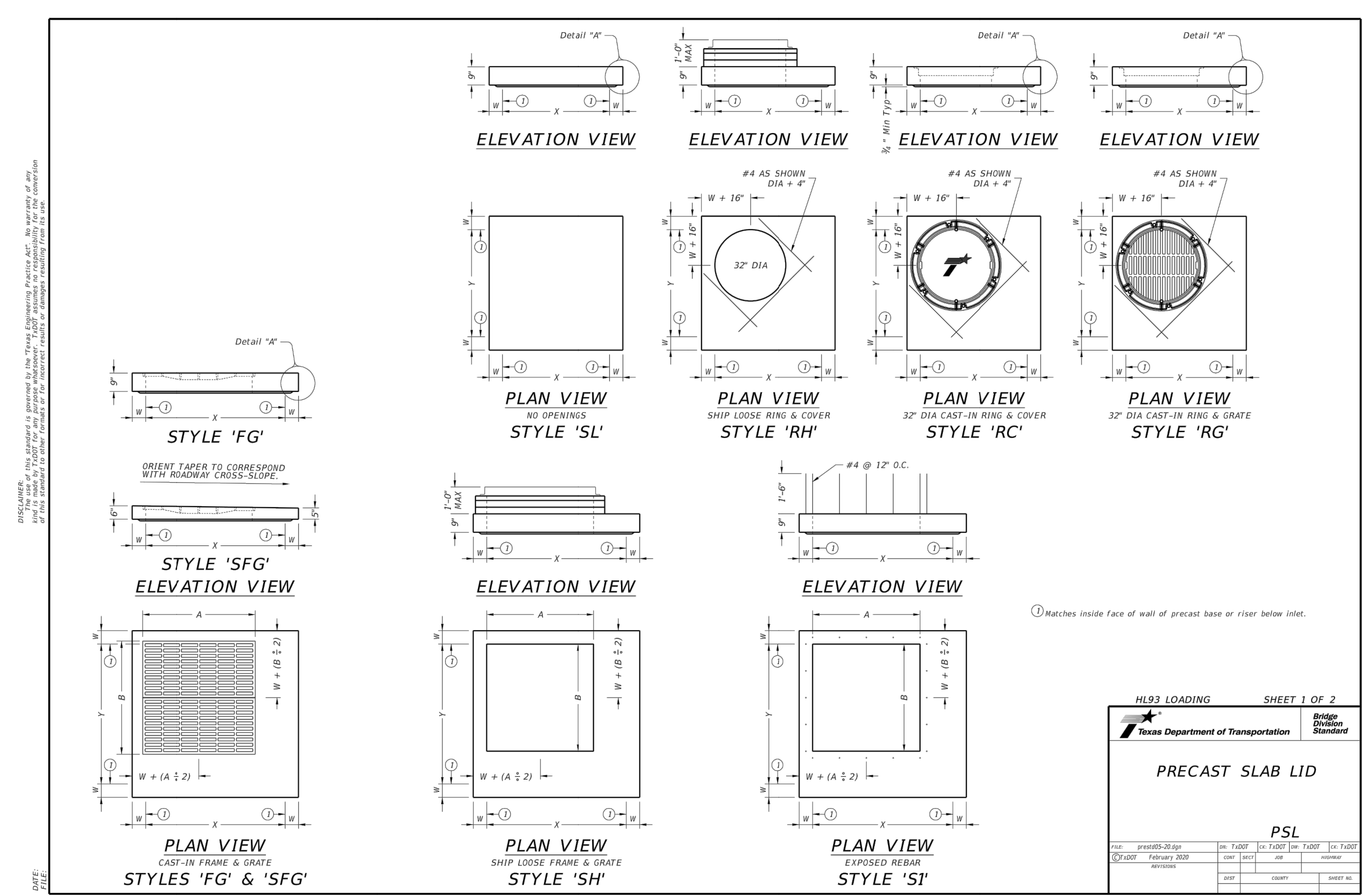
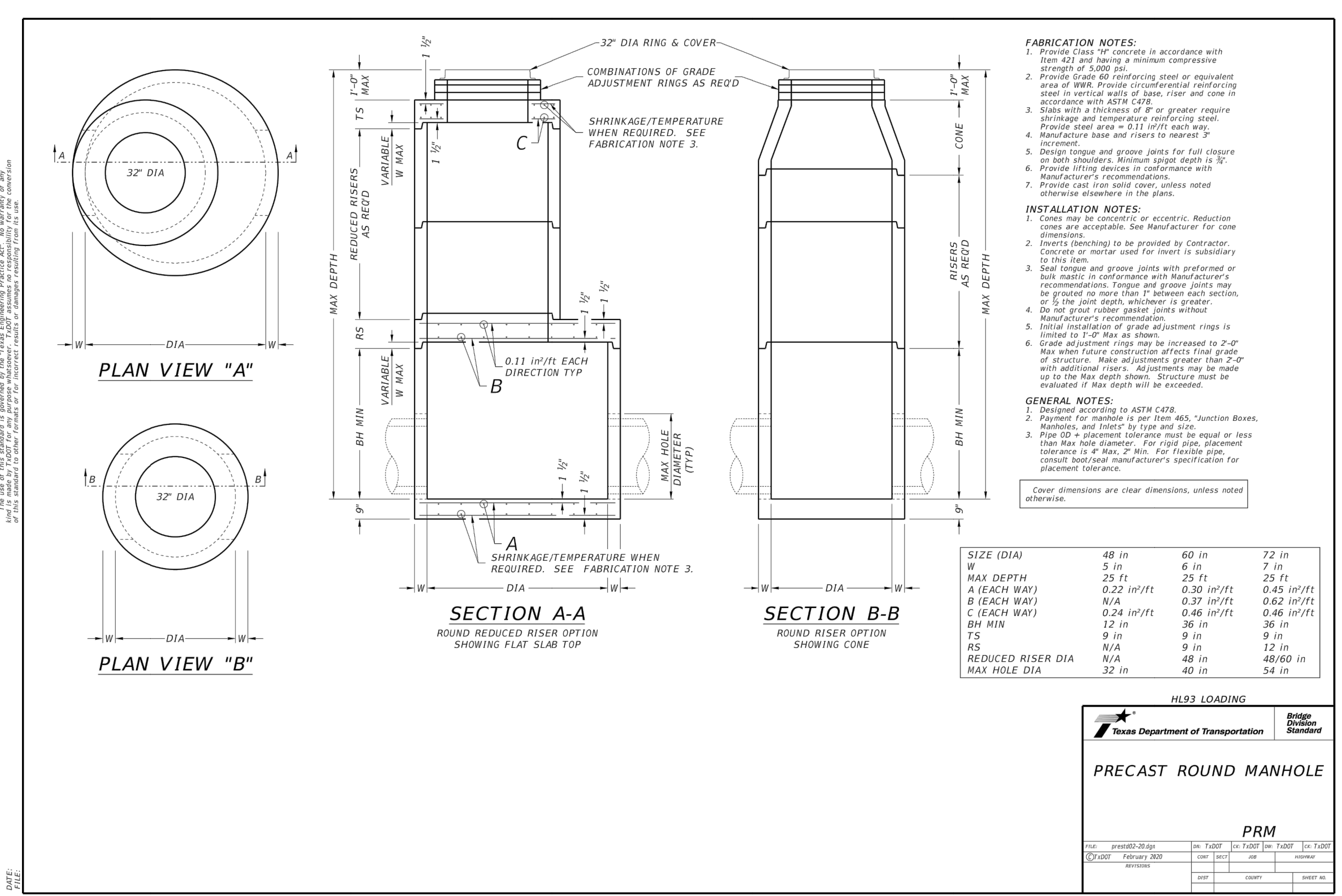

Date	MAX DEPTH = 25 ft to top of BASE SLAB												MAX DEPTH = 25 ft to top of BASE SLAB											
	Base Slab				Riser Wall				Below Grade (See Note 1)				Base Slab				Riser Wall				Below Grade (See Note 1)			
W	H	TS	RS	W	H	TS	RS	W	H	TS	RS	W	H	TS	RS	W	H	TS	RS	W	H	TS	RS	
48	25	0.22	0.24	0.24	0.24	0.24	0.24	0.24	0.24	0.24	0.24	0.24	0.24	0.24	0.24	0.24	0.24	0.24	0.24	0.24	0.24	0.24	0.24	0.24
60	25	0.22	0.24	0.24	0.24	0.24	0.24	0.24	0.24	0.24	0.24	0.24	0.24	0.24	0.24	0.24	0.24	0.24	0.24	0.24	0.24	0.24	0.24	0.24
72	25	0.22	0.24	0.24	0.24	0.24	0.24	0.24	0.24	0.24	0.24	0.24	0.24	0.24	0.24	0.24	0.24	0.24	0.24	0.24	0.24	0.24	0.24	0.24

FABRICATION NOTES:

- Provide Class II concrete in accordance with Item 427 and having a minimum compressive strength of 5,000 psi.
- Provide Class III reinforcing steel or equivalent steel in accordance with Item 428 and having a minimum yield strength of 60,000 psi.
- Design and provide reinforcement for full depth of base and riser sections. Reinforcement shall be provided in accordance with Item 428 and having a minimum yield strength of 60,000 psi.
- Provide reinforcement for full depth of base and riser sections. Reinforcement shall be provided in accordance with Item 428 and having a minimum yield strength of 60,000 psi.

INSTALLATION NOTES:

- Concrete shall be placed in accordance with Item 427 and having a minimum compressive strength of 5,000 psi.
- Reinforcement shall be provided in accordance with Item 428 and having a minimum yield strength of 60,000 psi.
- Reinforcement shall be provided in accordance with Item 428 and having a minimum yield strength of 60,000 psi.
- Reinforcement shall be provided in accordance with Item 428 and having a minimum yield strength of 60,000 psi.

HE32 LOADING

PDD

Texas Department of Transportation
Bridge Standard

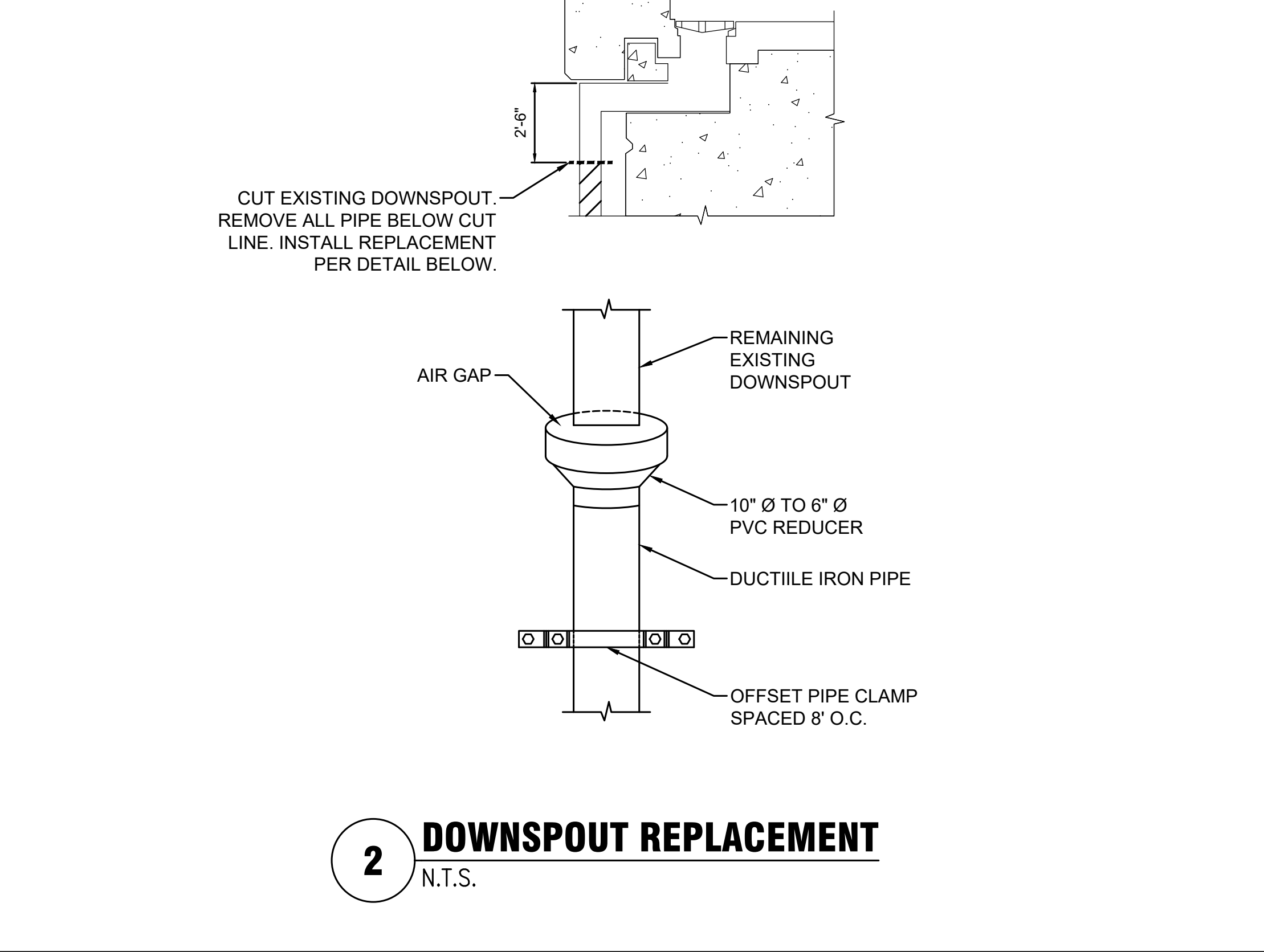

SITE LIGHTING SYMBOLS						LIGHTING CONTROL SYMBOLS						SINGLE LINE SYMBOLS						GENERAL DEMOLITION LEGEND																																																																																																																																									
						<p>3W XXa MANUAL, STAND ALONE LIGHT SWITCH</p> <p>SUBSCRIPT(S) INDICATES THE FOLLOWING:</p> <p>"a" CIRCUIT DESIGNATION "d" WALL MOUNTED DIMMER "EP" WALL MOUNTED EXPLOSION PROOF "K" WALL MOUNTED KEY OPERATED "NS-X" WALL MOUNTED NETWORK MASTER "OR" WALL MOUNTED OVERRIDE "OS" WALL MOUNTED OCCUPANCY SENSOR "P" WALL MOUNTED PILOT LIGHT "TM" WALL MOUNTED TIMER OPERATED "WP" WALL MOUNTED WEATHERPROOF "XX" CIRCUIT NUMBER "3W" WALL MOUNTED THREE-WAY "4W" WALL MOUNTED FOUR-WAY</p> <p>CL XXa OL XXa PHOTOCELL</p> <p>SUBSCRIPT(S) INDICATES THE FOLLOWING:</p> <p>"a" CIRCUIT DESIGNATION "CL" CLOSED LOOP "L" LONG RANGE "OL" OPEN LOOP "XX" CIRCUIT NUMBER</p> <p> LOW VOLTAGE LIGHTING CONTROL RELAY CABINET</p> <p>SUBSCRIPT(S) INDICATES THE FOLLOWING:</p> <p>"LRP" LIGHTING RELAY PANEL "LRSP" LIGHTING RELAY SATELLITE PANEL "LRSPD" LIGHTING RELAY SATELLITE PANEL (DIMMING)</p> <p> CONTACTOR</p> <p> TIME CLOCK</p>						<p>CIRCUIT BREAKER "A" INDICATES TRIP RATING/SETTING (AMPS)</p> <p>DRAW OUT CIRCUIT BREAKER "A" INDICATES TRIP RATING/SETTING (AMPS)</p> <p>FUSIBLE SWITCH "A" INDICATES DISCONNECT TRIP RATING AND FUSE SIZE, RESPECTIVELY (AMPS)</p> <p>AUTOMATIC TRANSFER SWITCH</p> <p>GROUND</p> <p>TRANSFORMER</p> <p>GROUND FAULT PROTECTIVE RELAY</p> <p>LONG TERM, SHORT TERM, INSTANTENOUS ANS GROUND FAULT PROTECTION</p> <p>SURGE PROTECTION DEVICE</p> <p>ELECTRIC UTILITY METER (CURRENT TRANSFORMER TYPE)</p> <p>FEEDER SIZE TAG - REFER TO FEEDER SCHEDULE</p>						<p>E - EXISTING ELECTRICAL EQUIPMENT (DEVICE) TO REMAIN IN SERVICE. NO WORK REQUIRED.</p> <p>ER - EXISTING ELECTRICAL EQUIPMENT (DEVICE) TO BE DISCONNECTED AND REMOVED.</p> <p>ERR - EXISTING ELECTRICAL EQUIPMENT (DEVICE) TO BE RELOCATED. CONTRACTOR SHALL INTERCEPT EXISTING CONDUIT AND WIRING AND EXTEND THEM TO NEW LOCATION. RECONNECT DEVICE AT NEW LOCATION AS INDICATED ON THE DRAWINGS.</p> <p>ERN - EXISTING ELECTRICAL EQUIPMENT (DEVICE) TO BE REPLACED WITH NEW AT SAME LOCATIONS. CONTRACTOR SHALL PROVIDE NEW EQUIPMENT (DEVICE) AS SPECIFIED. EXISTING RACEWAY AND WIRING TO REMAIN UNLESS NOTED OTHERWISE. RECONNECT NEW DEVICE FOR A WORKING SYSTEM.</p> <p>ED - EXISTING EQUIPMENT TO BE DISCONNECT FOR THE REMOVAL BY OTHERS. CONTRACTOR SHALL DISCONNECT AND REMOVE ALL ASSOCIATED ELECTRICAL EQUIPMENT, CONTROLS, CONDUIT AND WIRING.</p> <p>EN - NEW LOCATED FOR EXISTING ELECTRICAL EQUIPMENT, LIGHTING FIXTURES, DEVICE BEING RELOCATED. CONTRACTOR SHALL EXTEND EXISTING CONDUIT AND WIRING TO NEW LOCATION. PROVIDE NEW CONDUIT AND WIRING WHERE REQUIRED.</p>																																																																																																																																									
POWER SYMBOLS						ABBREVIATIONS						GROUNDING SYMBOLS						GENERAL NOTES																																																																																																																																									
<p>SUBSCRIPT INDICATES THE FOLLOWING:</p> <p>"AC" MOUNTED 6" ABOVE COUNTER "AV" AUDIOVISUAL, COMPUTER GRADE "CR" CHILD RESISTANT (SAFETY TYPE) "EM" FED BY EMERGENCY CIRCUIT "EP" EXPLOSION PROOF "EW" ELECTRIC WATER COOLER "GFI" GROUND FAULT CIRCUIT INTERRUPTER "IG" ISOLATED GROUND "P" POWER CONNECTION "WP" WATERPROOF COVER "F" CIRCUIT NUMBER</p> <p> DUPLEX RECEPTACLE</p> <p> JUNCTION BOX</p> <p> JUNCTION BOX WITH FLEXIBLE CONDUIT</p>						<p>ABBREVIATIONS</p> <table border="0"> <tr> <td>A</td><td>AMPS</td><td>MCB</td><td>MAIN CIRCUIT BREAKER</td> </tr> <tr> <td>AFF</td><td>ABOVE FINISHED FLOOR</td><td>MCC</td><td>MOTOR CONTROL CENTER</td> </tr> <tr> <td>AIC</td><td>AMPERES INTERRUPTING CAPACITY</td><td>MDF</td><td>MAIN DISTRIBUTION FRAME</td> </tr> <tr> <td>ATS</td><td>AUTOMATIC TRANSFER SWITCH</td><td>MECH</td><td>MECHANICAL</td> </tr> <tr> <td>BAS</td><td>BUILDING AUTOMATION SYSTEM</td><td>MIN</td><td>MINIMUM</td> </tr> <tr> <td>C</td><td>CONDUIT</td><td>MLO</td><td>MAIN LUIS ONLY</td> </tr> <tr> <td>C/B</td><td>CIRCUIT BREAKER</td><td>MOC</td><td>MAIN OVERCURRENT PROTECTION</td> </tr> <tr> <td>CATV</td><td>CABLE TELEVISION</td><td>MTD</td><td>MOUNTED</td> </tr> <tr> <td>CCT</td><td>CIRCUIT</td><td>N</td><td>NEUTRAL</td> </tr> <tr> <td>CCTV</td><td>CLOSED CIRCUIT TELEVISION</td><td>N/A</td><td>NOT APPLICABLE</td> </tr> <tr> <td>CEC</td><td>CHICAGO ELECTRIC CODE</td><td>NEC</td><td>NATIONAL ELECTRIC CODE</td> </tr> <tr> <td>CP</td><td>CONTROL PANEL</td><td>NIC</td><td>NOT IN CONTRACT</td> </tr> <tr> <td>CR</td><td>CHILD RESISTANT</td><td>NTS</td><td>NOT TO SCALE</td> </tr> <tr> <td>CT</td><td>CURRENT TRANSFORMER</td><td>PLUMB</td><td>PLUMBING</td> </tr> <tr> <td>CU</td><td>COPPER</td><td>PRI</td><td>PRIMARY</td> </tr> <tr> <td>DS</td><td>DISCONNECT SWITCH</td><td>RGS</td><td>RIGID GALVANIZED STEEL</td> </tr> <tr> <td>ELEC</td><td>ELECTRIC, ELECTRICAL</td><td>SEC</td><td>SECONDARY</td> </tr> <tr> <td>EM</td><td>EMERGENCY</td><td>SPD</td><td>SURGE PROTECTION DEVICE</td> </tr> <tr> <td>EQUIP</td><td>EQUIPMENT</td><td>SPEC</td><td>SPECIFICATIONS</td> </tr> <tr> <td>EX</td><td>EXISTING</td><td>SWBD</td><td>SWITCHBOARD</td> </tr> <tr> <td>FLA</td><td>FULL LOAD AMPS</td><td>SWGR</td><td>SWITCHGEAR</td> </tr> <tr> <td>FU</td><td>FUSE</td><td>TYP</td><td>TYPICAL</td> </tr> <tr> <td>GFI</td><td>GROUND FAULT INTERRUPTER</td><td>UL</td><td>UNDERWRITER LABORATORIES</td> </tr> <tr> <td>GRD</td><td>GROUND</td><td>UNO</td><td>UNLESS NOTED OTHERWISE</td> </tr> <tr> <td>HMLS</td><td>HIGH MAST LIGHTING SYSTEM</td><td>UPS</td><td>UNINTERRUPTIBLE POWER SUPPLY</td> </tr> <tr> <td>HP</td><td>HORSEPOWER</td><td>V</td><td>VOLTS</td> </tr> <tr> <td>HZ</td><td>HERTZ</td><td>VA</td><td>VOLTS/AMPS</td> </tr> <tr> <td>IDF</td><td>INTERMEDIATE DISTRIBUTION FRAME</td><td>W</td><td>WATTS</td> </tr> <tr> <td>IG</td><td>ISOLATED GROUND</td><td>WG</td><td>WIRE GUARD</td> </tr> <tr> <td>KVA</td><td>KILO-VOLT AMP</td><td>WP</td><td>WEATHERPROOF</td> </tr> <tr> <td>KW</td><td>KILOWATT</td><td>WR</td><td>WITHSTAND RATING</td> </tr> <tr> <td>MAX</td><td>MAXIMUM</td><td>XFMR</td><td>TRANSFORMER</td> </tr> <tr> <td></td><td></td><td>XP</td><td>EXPLOSION PROOF</td> </tr> </table>						A	AMPS	MCB	MAIN CIRCUIT BREAKER	AFF	ABOVE FINISHED FLOOR	MCC	MOTOR CONTROL CENTER	AIC	AMPERES INTERRUPTING CAPACITY	MDF	MAIN DISTRIBUTION FRAME	ATS	AUTOMATIC TRANSFER SWITCH	MECH	MECHANICAL	BAS	BUILDING AUTOMATION SYSTEM	MIN	MINIMUM	C	CONDUIT	MLO	MAIN LUIS ONLY	C/B	CIRCUIT BREAKER	MOC	MAIN OVERCURRENT PROTECTION	CATV	CABLE TELEVISION	MTD	MOUNTED	CCT	CIRCUIT	N	NEUTRAL	CCTV	CLOSED CIRCUIT TELEVISION	N/A	NOT APPLICABLE	CEC	CHICAGO ELECTRIC CODE	NEC	NATIONAL ELECTRIC CODE	CP	CONTROL PANEL	NIC	NOT IN CONTRACT	CR	CHILD RESISTANT	NTS	NOT TO SCALE	CT	CURRENT TRANSFORMER	PLUMB	PLUMBING	CU	COPPER	PRI	PRIMARY	DS	DISCONNECT SWITCH	RGS	RIGID GALVANIZED STEEL	ELEC	ELECTRIC, ELECTRICAL	SEC	SECONDARY	EM	EMERGENCY	SPD	SURGE PROTECTION DEVICE	EQUIP	EQUIPMENT	SPEC	SPECIFICATIONS	EX	EXISTING	SWBD	SWITCHBOARD	FLA	FULL LOAD AMPS	SWGR	SWITCHGEAR	FU	FUSE	TYP	TYPICAL	GFI	GROUND FAULT INTERRUPTER	UL	UNDERWRITER LABORATORIES	GRD	GROUND	UNO	UNLESS NOTED OTHERWISE	HMLS	HIGH MAST LIGHTING SYSTEM	UPS	UNINTERRUPTIBLE POWER SUPPLY	HP	HORSEPOWER	V	VOLTS	HZ	HERTZ	VA	VOLTS/AMPS	IDF	INTERMEDIATE DISTRIBUTION FRAME	W	WATTS	IG	ISOLATED GROUND	WG	WIRE GUARD	KVA	KILO-VOLT AMP	WP	WEATHERPROOF	KW	KILOWATT	WR	WITHSTAND RATING	MAX	MAXIMUM	XFMR	TRANSFORMER			XP	EXPLOSION PROOF	<p>GROUNDING SYMBOLS</p> <p> 10 FT COPPER GROUND ROD</p> <p> 10 FT COPPER GROUND ROD WITH TEST WELL</p> <p> GROUNDING TRIAD. PROVIDE A MINIMUM 10'-0" DISTANCE BETWEEN ROUND RODS</p>						<p>1. ALL ELECTRICAL DRAWINGS ARE TO BE READ IN CONJUNCTION WITH THE PROJECT SPECIFICATIONS AND ALL OTHER DRAWINGS RELATED TO THE PERFORMANCE OF THE WORK.</p> <p>2. THE CONTRACTOR RESPONSIBLE FOR THE EXECUTION OF THIS WORK SHALL BECOME THOROUGHLY FAMILIAR WITH THE PROJECT SPECIFICATIONS BEFORE COMMENCING ANY WORK. THE PROJECT SPECIFICATIONS ARE DRAWINGS FORM THE BASIS OF THIS CONTRACT REQUIREMENTS AND INCLUDE THE TYPE AND BASIS OF THIS CONTRACT REQUIREMENTS AND INCLUDED THE TYPE AND GRADE OF MATERIALS TO BE INSTALLED. EQUIPMENT TO BE FURNISHED, THE MANNER BY WHICH TO BE INSTALLED AND WHERE TO BE LOCATED. IN THE MANNER BY WHICH TO BE INSTALLED AND WHERE TO BE LOCATED. IN THE EVENT OF A CONFLICT BETWEEN THE PROJECT SPECIFICATIONS AND DRAWINGS, SPECIFICATIONS GOVERN UNLESS THE ARCHITECT/ENGINEER DIRECTS OTHERWISE.</p> <p>3. THE CONTRACTOR SHALL CHECK CAREFULLY ALL CONSTRUCTION DRAWINGS AND SPECIFICATIONS THAT ARE PART OF THIS PROJECT TO INSURE THAT NO FIXTURE, OUTLET, ALARM STATION OR CONTROL AND POWER WIRING IS OMITTED. HE SHALL CONDUIT ALL TRADES FURNISHING EQUIPMENT AND OBTAIN FROM THEM ALL DATA. IN SOME CASES EQUIPMENT, FIXTURES AND DEVICES ARE SHOWN ONLY. ASCERTAIN AND PROVIDE THE WIRING AND CONTROL STATIONS REQUIRED TO THE PROPER FUNCTION OF BUILDING EQUIPMENT.</p> <p>4. EQUIPMENT LABELS AND INSTRUCTIONS REGARDING THE APPLICATION AND INSTALLATION OF THE LISTED EQUIPMENT SHALL BE FOLLOWED TO INSURE THAT THE EQUIPMENT IS BEING INSTALLED IN ACCORDANCE WITH THE MANUFACTURER'S LISTING INSTRUCTIONS. THE TEMPERATURE RATINGS OF THE EQUIPMENT TERMINATIONS MUST BE CAREFULLY CORRELATED WITH THE CONDUCTOR AMPACITY TO PREVENT OVERHEATING AND PREMATURE FAILURE.</p> <p>5. COORDINATE WITH OTHER TRADES AND INSTALL CONDUIT AND BOXES TO CLEAR EMBEDDED DUCTS, OPENINGS AND OTHER STRUCTURAL FEATURES.</p> <p>6. ALL LIGHTING FIXTURES ARE TO BE LOCATED AS REQUIRED ON THE JOB TO CLEAR DUCTS, PIPING, EQUIPMENT, AND/OR MECHANICAL UNITS.</p> <p>7. CONDUIT RUNS SHOWN ON THE DRAWINGS ARE DIAGRAMMATIC. ALL CONDUITS SHALL RUN CONCEALED, EXCEPT IN EQUIPMENT ROOMS AND WHERE APPROVED BY THE ARCHITECT.</p> <p>8. FURNISH AND INSTALL EQUIPMENT DISCONNECT SWITCHES IN COMPLIANCE WITH NEC.</p> <p>9. ALL OUTDOOR RECEPTACLES SHALL BE WEATHERPROOF, GFCI AND UL LISTED FOR WET LOCATIONS.</p> <p>10. NO WIRING SHALL BE DONE PRIOR TO THE CONTRACTOR'S REVIEW OF THE PROJECT EQUIPMENT SHOP DRAWINGS AND COORDINATION WITH THE DESIGN DOCUMENTS. ANY DISCREPANCIES SHALL BE BROUGHT TO THE ARCHITECT/ENGINEER ATTENTION FOR FINAL RESOLUTION. WORK THAT HAS TO BE REPLACED DUE TO LACK OF PROPER SHOP DRAWINGS CO-ORDINATION SHALL BE DONE AT CONTRACTOR'S EXPENSE.</p> <p>11. MOTOR SIZES AND LOCATIONS SHOWN ON THE DRAWINGS ARE BASED ON INFORMATION OBTAINED DURING DESIGN. VERIFY THE ACTUAL LOCATIONS AND PROVIDE WIRING AND PROTECTION OF PROPER SIZES AS REQUIRED. WIRE MOTORS FOR PROPER DIRECTION OF ROTATION AND CHECK ROTATION AT START-UP.</p> <p>12. ALL BRANCH CIRCUIT FEEDERS SHALL BE PROVIDED WITH SEPARATE GROUNDING CONDUCTORS.</p> <p>13. ALL 120V, 1PH BRANCH CIRCUITS SHALL HAVE DEDICATED NEUTRALS.</p> <p>14. UNLESS NOTED OTHERWISE, 15 AND 20 AMP 120 VOLT BRANCH CIRCUITS SHALL UTILIZE MINIMUM #12 AWG FOR CIRCUITS UP TO 75' IN LENGTH #10 AWG FOR CIRCUITS 76 TO 100' IN LENGTH, AND #8 AWG FOR CIRCUITS OVER 100' IN LENGTH. THE LENGTH OF THE CIRCUIT SHALL BE MEASURED FROM THE LAST DEVICE OR OUTLET ON THE CIRCUIT TO THE PANEL/SOURCE.</p> <p>15. UNLESS NOTED OTHERWISE, 15 AND 20 AMP 277 VOLT BRANCH CIRCUITS SHALL UTILIZE MINIMUM #12 AWG FOR CIRCUITS UP TO 100' IN LENGTH #10 AWG FOR CIRCUITS 100 TO 150' IN LENGTH, #8 AWG FOR CIRCUITS 150 TO 300' IN LENGTH, AND #6 AWG FOR CIRCUITS OVER 300'. THE LENGTH OF THE CIRCUIT SHALL BE MEASURED FROM THE LAST DEVICE OR OUTLET ON THE CIRCUIT TO THE PANEL/SOURCE.</p> <p>16. CONDUIT FOR ALL ELECTRICAL WORK RUNNING ACROSS THE BUILDING CONSTRUCTION JOINT SHALL BE PROVIDED WITH CONDUIT EXPANSION FITTINGS (WITH BONDING JUMPERS ACROSS EACH FITTINGS.)</p> <p>17. PROVIDE FUNCTIONAL TESTING AND CERTIFICATION OF THE LIGHTING CONTROL SYSTEM WHICH MUST BE PERFORMED BY AN INDEPENDENT PARTY (NOT DIRECTLY INVOLVED IN DESIGN OR CONSTRUCTION OF THE PROJECT) AND HIRED BY THE DIV. 26 CONTRACTOR TO ASSURE COMPLIANCE WITH IECC-2015 ART. C408.3, UNDER THE IECC, THIS INDEPENDENT PARTY MUST BE A REGISTERED DESIGN PROFESSIONAL.</p> <p>THE TESTING SHALL ENSURE THAT CONTROL HARDWARE AND SOFTWARE ARE CALIBRATED, ADJUSTED, PROGRAMMED, AND IN PROPER WORKING CONDITION IN ACCORDANCE WITH THE MANUFACTURER'S INSTALLATION INSTRUCTIONS AND THESE CONSTRUCTION DOCUMENTS. THIS TESTING SHALL INCLUDE OCCUPANCY SENSORS, TIME SWITCH CONTROLS, TIME CLOCK PROGRAMMING, AND DAYLIGHT RESPONSIVE CONTROLS. IECC-2015 ART. C408.3 FURTHER OUTLINE THE TESTING REQUIREMENTS.</p> <p>PROVIDE DOCUMENTATION OF THE FINAL CONSTRUCTION CONDITIONS (AS-BUILTS), LIGHTING CONTROL PROGRAMMING, EQUIPMENT O&M MANUALS, AND FUNCTIONAL TESTING REPORTS WITHIN 90 DAYS OF THE RECEIPT OF THE CERTIFICATE OF OCCUPANCY, OR WITHIN 90 DAYS OF SYSTEM ACCEPTANCE, WHICHEVER OCCURS FIRST. THESE DOCUMENTS SHALL BE PROVIDED TO THE EOR AND THE OWNER OR OWNER'S AUTHORIZED AGENT, AND IN FULL COMPLIANCE WITH IECC-2015 ART. C408.3 REQUIREMENTS.</p>					
A	AMPS	MCB	MAIN CIRCUIT BREAKER																																																																																																																																																								
AFF	ABOVE FINISHED FLOOR	MCC	MOTOR CONTROL CENTER																																																																																																																																																								
AIC	AMPERES INTERRUPTING CAPACITY	MDF	MAIN DISTRIBUTION FRAME																																																																																																																																																								
ATS	AUTOMATIC TRANSFER SWITCH	MECH	MECHANICAL																																																																																																																																																								
BAS	BUILDING AUTOMATION SYSTEM	MIN	MINIMUM																																																																																																																																																								
C	CONDUIT	MLO	MAIN LUIS ONLY																																																																																																																																																								
C/B	CIRCUIT BREAKER	MOC	MAIN OVERCURRENT PROTECTION																																																																																																																																																								
CATV	CABLE TELEVISION	MTD	MOUNTED																																																																																																																																																								
CCT	CIRCUIT	N	NEUTRAL																																																																																																																																																								
CCTV	CLOSED CIRCUIT TELEVISION	N/A	NOT APPLICABLE																																																																																																																																																								
CEC	CHICAGO ELECTRIC CODE	NEC	NATIONAL ELECTRIC CODE																																																																																																																																																								
CP	CONTROL PANEL	NIC	NOT IN CONTRACT																																																																																																																																																								
CR	CHILD RESISTANT	NTS	NOT TO SCALE																																																																																																																																																								
CT	CURRENT TRANSFORMER	PLUMB	PLUMBING																																																																																																																																																								
CU	COPPER	PRI	PRIMARY																																																																																																																																																								
DS	DISCONNECT SWITCH	RGS	RIGID GALVANIZED STEEL																																																																																																																																																								
ELEC	ELECTRIC, ELECTRICAL	SEC	SECONDARY																																																																																																																																																								
EM	EMERGENCY	SPD	SURGE PROTECTION DEVICE																																																																																																																																																								
EQUIP	EQUIPMENT	SPEC	SPECIFICATIONS																																																																																																																																																								
EX	EXISTING	SWBD	SWITCHBOARD																																																																																																																																																								
FLA	FULL LOAD AMPS	SWGR	SWITCHGEAR																																																																																																																																																								
FU	FUSE	TYP	TYPICAL																																																																																																																																																								
GFI	GROUND FAULT INTERRUPTER	UL	UNDERWRITER LABORATORIES																																																																																																																																																								
GRD	GROUND	UNO	UNLESS NOTED OTHERWISE																																																																																																																																																								
HMLS	HIGH MAST LIGHTING SYSTEM	UPS	UNINTERRUPTIBLE POWER SUPPLY																																																																																																																																																								
HP	HORSEPOWER	V	VOLTS																																																																																																																																																								
HZ	HERTZ	VA	VOLTS/AMPS																																																																																																																																																								
IDF	INTERMEDIATE DISTRIBUTION FRAME	W	WATTS																																																																																																																																																								
IG	ISOLATED GROUND	WG	WIRE GUARD																																																																																																																																																								
KVA	KILO-VOLT AMP	WP	WEATHERPROOF																																																																																																																																																								
KW	KILOWATT	WR	WITHSTAND RATING																																																																																																																																																								
MAX	MAXIMUM	XFMR	TRANSFORMER																																																																																																																																																								
		XP	EXPLOSION PROOF																																																																																																																																																								
PANELBOARD SYMBOLS						FIRE ALARM SYMBOLS						PANELBOARD IDENTIFICATION LOGIC																																																																																																																																															
<p>PLAN SYMBOL</p> <p> SWITCHGEAR, SWITCHBOARD OR MOTOR CONTROL CENTER, DASHED LINES INDICATE FUTURE SECTIONS, DOUBLE LINE INDICATES FRONT</p> <p> SURFACE MOUNTED DISTRIBUTION PANELBOARD</p> <p> SURFACE MOUNTED PANELBOARD</p>						<p> AUDIO ALARM DEVICE WITH VISUAL ALARM DEVICE</p> <p> VISUAL ALARM DEVICE</p> <p> SYSTEM SMOKE DETECTOR</p> <p> SPRINKLER PRESSURE SWITCH</p> <p> TROUBLE BELL</p> <p> FIRE ALARM CONTROL PANEL</p>						<p>SYSTEM/SOURCE</p> <p>TYPE</p> <p>SEQUENCE NUMBER</p> <p>NUMBERS IN SEQUENCE</p> <p>EM - EMERGENCY BLANK - NORMAL</p> <p>DP - DISTRIBUTION PANELBOARD KP - KITCHEN LP - LIGHTING PP - POWER RP - RECEPTACLES SWGR - SWITCHGEAR</p>																																																																																																																																															
RACEWAYS & WIRING																																																																																																																																																											
<p> CONDUIT HOMERUN</p> <p> PHASE NEUTRAL GROUND</p> <p> CONDUIT - SURFACE MOUNTED OR CONCEALED</p> <p> CONDUIT UNDERFLOOR OR UNDERGROUND</p> <p> CONDUIT TURNED UP</p> <p> CONDUIT TURNED DOWN</p> <p> CONCRETE ENCASED CONDUIT</p> <p> FLEXIBLE CONDUIT</p> <p> JUNCTION BOX</p> <p> JUNCTION BOX - WALL MOUNTED</p> <p> JUNCTION BOX UNDER FLOOR</p> <p> PULLBOX</p> <p> CONDUIT EXPANSION JOINT</p>																																																																																																																																																											

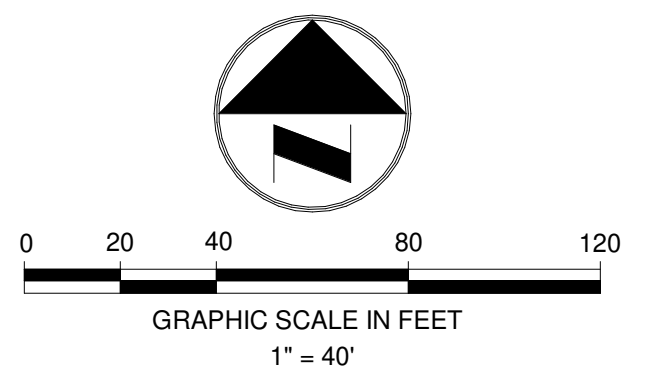

- GENERAL NOTES:**
- REFER TO PHASING DEMARCATION LINES ON PLANS.
 - CARE SHALL BE TAKEN DURING DEMOLITION TO PRESERVE THE FOLLOWING: LARGE SHADE TREES, LARGE FLAG POLES, HIGHWAY SIGNAGE, REMAINING STRUCTURES, ETC.
 - ALL EXISTING HANDHOLES THAT ARE NOT COMPLETELY ABANDONED BY THIS WORK SHALL REMAIN AS IS.

- KEYED NOTES:**
- EXISTING LED WALL PACKS SERVING THE LOWER ROADWAY SHALL REMAIN IN PLACE. UNO, WIRING AND CONDUIT FEEDING WALL PACKS SHALL BE REMOVED AND REPLACED IN FULL.
 - EXISTING LANDSCAPE FIXTURES, CONDUIT, AND WIRING SHALL BE REMOVED IN FULL.
 - NOT USED
 - ROUGH LOCATION OF EXISTING TO REMAIN HID HIGHMAST LIGHT POLE.
 - EXISTING LED HIGHMAST LIGHTS SERVING THE RAMPS ARE TO REMAIN IN PLACE. CONDUIT AND WIRING SHALL BE PRESERVED.
 - EXISTING HID FLOODS FOR ROADWAY SIGNAGE SHALL BE REMOVED AND REPLACED IN FULL. CONDUIT AND WIRING SHALL BE REMOVED AND REPLACED IN FULL.
 - NOT USED
 - EXISTING HID AND FLUORESCENT LIGHTS MOUNTED TO ROAD STRUCTURE SERVING PASSENGER DROP OFF ZONES/SIDEWALKS SHALL BE REMOVED AND REPLACED IN FULL. ASSOCIATED CONDUIT AND WIRING SHALL BE REMOVED AND REPLACED IN FULL TYPICAL FOR HATCHED AREA.
 - EXISTING DOWNLIGHTS EMBEDDED IN OVERPASS SHALL BE RETROFITTED WITH LED RETROFIT KITS.
 - RELOCATION REQUIRED. COORDINATE THE RELOCATION OF EXISTING WALL PACK WITH NEW ELECTRICAL ENCLOSURE.
 - EXISTING WALL PACK WALL MOUNTED ON COLUMN LOCATED UNDERNEATH RAMP.
 - EXISTING ELECTRICAL DEVICE TO REMAIN.

NOTE TO REVIEWER:
PHASING PLANS WILL REQUIRE ADDITIONAL COORDINATION BETWEEN GARAGE AND TERMINAL WORK PRIOR TO 100% SUBMITTAL.

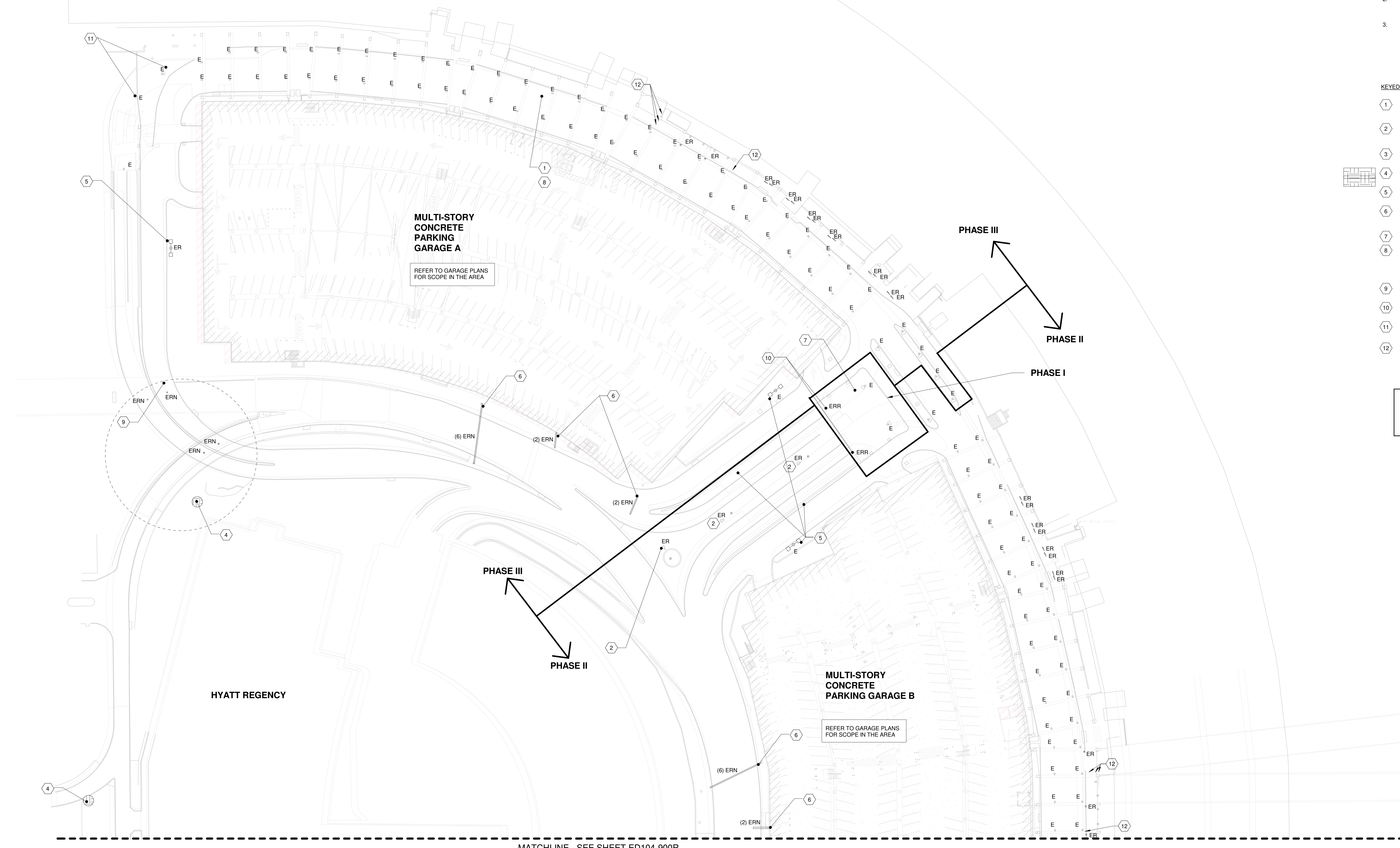

1 LOWER ROADWAY - LIGHTING DEMOLITION - NORTH
1" = 40'-0"

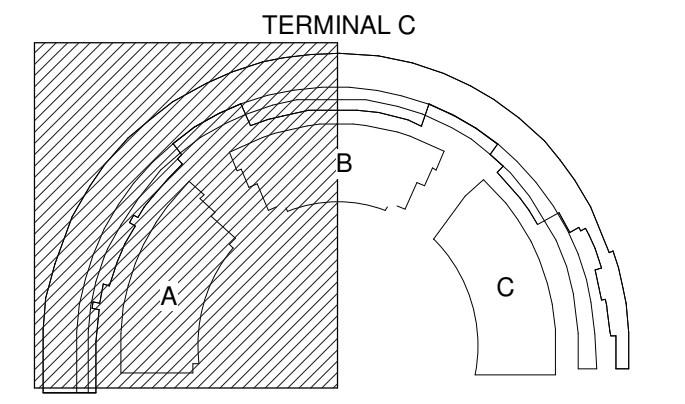

Permits:
A21-1883 - Terminal C Garage C
B22-0021 - Terminal C Garage B
B22-0022 - Terminal C Garage A
B22-0023 - Terminal C Roadway

2330 N INTERNATIONAL PARKWAY
DFW AIRPORT, TX 75261



PROJECT NUMBER: TFD007

DRAWN BY: BMAY
APPROVED BY: RL/DLS
ISSUE DATE: 2022-07-28

NOT FOR BID OR CONSTRUCTION

NO.	DATE	DESCRIPTION
2021-10-29	30% DESIGN	
2022-01-06	70% DESIGN	
2022-08-01	100% DESIGN	
2022-07-28	100% ISSUED FOR PERMIT (IFP)	

PROJECT NUMBER: TFD007

TERMINAL C GARAGE AND ROADWAYS
LIGHTING DEMOLITION - LOWER ROADWAY, NORTH

PERMIT NUMBER: A21-1883

SHEET NUMBER
ED103-900R

SCALE(S) AS NOTED ON THIS SHEET ARE BASED ON A FULL SIZE 30 X 42 SHEET.

MATCHLINE - SEE SHEET ED103-900R

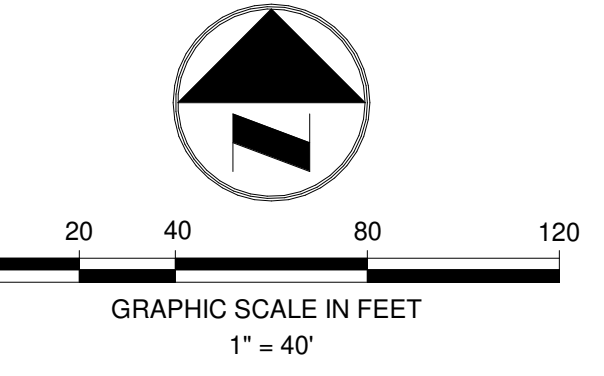

HYATT REGENCY

MULTI-STORY CONCRETE PARKING GARAGE B
REFER TO GARAGE PLANS FOR SCOPE IN THE AREA

MULTI-STORY CONCRETE PARKING GARAGE C
REFER TO GARAGE PLANS FOR SCOPE IN THE AREA

GENERAL NOTES:

- REFER TO PHASING DEMARCATION LINES ON PLANS.
- CARE SHALL BE TAKEN DURING DEMOLITION TO PRESERVE THE FOLLOWING: LARGE SHADE TREES, LARGE FLAG POLES, HIGHWAY SIGNAGE, REMAINING STRUCTURES, ETC.
- ALL EXISTING HANDHOLES THAT ARE NOT COMPLETELY ABANDONED BY THIS WORK SHALL BE REMAIN AS IS.

KEYED NOTES:

- EXISTING LED WALL PACKS SERVING THE LOWER ROADWAY SHALL REMAIN IN PLACE. UNCG WIRING AND CONDUIT FEEDING WALL PACKS SHALL BE REMOVED AND REPLACED IN FULL. TYPICAL FOR HATCHED AREA.
- NOT USED.
- NOT USED.
- ROUGH LOCATION OF EXISTING TO REMAIN HID HIGH/MAST LIGHT POLE.
- EXISTING LED HIGH/MAST LIGHTS SERVING THE RAMPS ARE TO REMAIN IN PLACE. CONDUIT AND WIRING SHALL BE PRESERVED.
- EXISTING HID FLOODS FOR ROADWAY SIGNAGE SHALL BE REMOVED AND REPLACED IN FULL. CONDUIT AND WIRING SHALL BE REMOVED AND REPLACED IN FULL.
- NOT USED.
- EXISTING HID AND FLUORESCENT LIGHTS MOUNTED TO ROAD STRUCTURE SERVING PASSENGER DROP OFF ZONES/SIDEWALKS SHALL BE REMOVED AND REPLACED IN FULL. ASSOCIATED CONDUIT AND WIRING SHALL BE REMOVED AND REPLACED IN FULL. TYPICAL FOR HATCHED AREA.
- RELOCATION REQUIRED. COORDINATE THE RELOCATION OF EXISTING WALL PACK WITH NEW ELECTRICAL ENCLOSURE.
- EXISTING ELECTRICAL DEVICE TO REMAIN.

NOTE TO REVIEWER:
PHASING PLANS WILL REQUIRE ADDITIONAL COORDINATION BETWEEN GARAGE AND TERMINAL WORK PRIOR TO 100% SUBMITTAL.

(4) ERN

6

PHASE II

PHASE I

(2) ERN

6

5

9

1

8

(4) ERN

6

(2) ERN

6

(2) ERN

6

PHASE I

PHASE II

1 LOWER ROADWAY - LIGHTING DEMOLITION - SOUTH
1" = 40'-0"

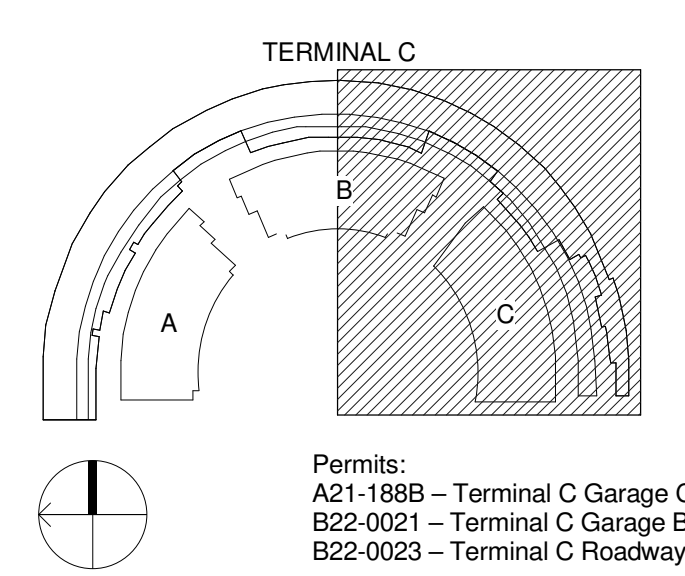

Permits:
A21-1883 - Terminal C Garage C
B22-0021 - Terminal C Garage B
B22-0023 - Terminal C Roadway



2330 N INTERNATIONAL PARKWAY
DFW AIRPORT, TX 75261

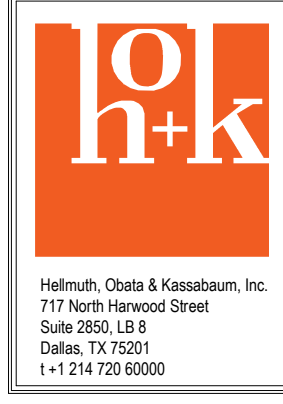

Primera

Joseph Michael Avram
12736
Dallas, TX 75201
1-214-721-6000

Primera Engineers, Inc.
3000 Easton Trail
Suite 214
Coppell, TX 75011
1-972-899-8910

PROJECT NUMBER: TFD007

DRAWN BY: BMAY
APPROVED BY: RL/DS
ISSUE DATE: 2022-07-28

NOT FOR BID OR CONSTRUCTION

NO.	DATE	DESCRIPTION
2021-12-28	30% DESIGN	
2022-01-06	70% DESIGN	
2022-03-01	100% DESIGN	
2022-07-28	100% ISSUED FOR PERMIT (IFP)	

TERMINAL C GARAGE AND ROADWAYS
LIGHTING DEMOLITION - LOWER ROADWAY, SOUTH

PROJECT NUMBER: TFD-007

PERMIT NUMBER: A21-1883

SHEET NUMBER
ED104-900R

SCALE(S) AS NOTED ON THIS SHEET ARE BASED ON A FULL SIZE 30 X 42 SHEET.

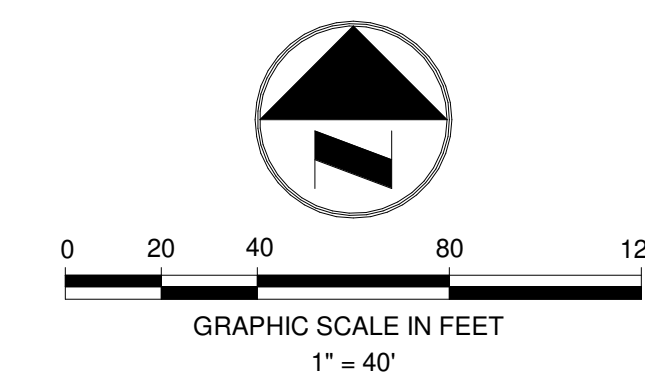

GENERAL NOTES:

1. REFER TO PHASING DEMARCATION LINES ON PLANS.
2. CARE SHALL BE TAKEN DURING DEMOLITION TO PRESERVE THE FOLLOWING: LARGE SHADE TREES, LARGE FLAG POLES, HIGHWAY SIGNAGE, REMAINING STRUCTURES, ETC.
3. ALL EXISTING HANDHOLES THAT ARE NOT COMPLETELY ABANDONED BY THIS WORK SHALL REMAIN AS IS.

KEYED NOTES:

- ① EXIST HID LIGHTS AND POLES MOUNTED TO GARAGE STRUCTURE THAT SERVES THE ELEVATED ROADWAY SHALL BE REMOVED AND REPLACED IN FULL. WIRING AND CONDUIT FEEDINGS SHALL BE REMOVED AND REPLACED IN FULL. TYPICAL FOR HATCHED AREA.
- ② EXISTING LIGHTS MOUNTED TO SHADE AND CONCRETE STRUCTURE ON TERMINAL BUILDING SIDE ARE NOT IN SCOPE. REFER TO TERMINAL RENOVATIONS. TYPICAL FOR HATCHED AREA.
- ③ EXISTING LED HIGHMAST LIGHTS SERVING THE RAMPS ARE TO REMAIN IN PLACE. CONDUIT AND WIRING SHALL BE PRESERVED. TYPICAL FOR HATCHED AREA.
- ④ EXISTING DOWNLIGHTS EMBEDDED IN OVERPASS SHALL BE RETROFITTED WITH LED RETROFIT KITS.

NOTE TO REVIEWER:
PHASING PLANS WILL REQUIRE ADDITIONAL COORDINATION BETWEEN GARAGE AND TERMINAL WORK PRIOR TO 100% SUBMITTAL.

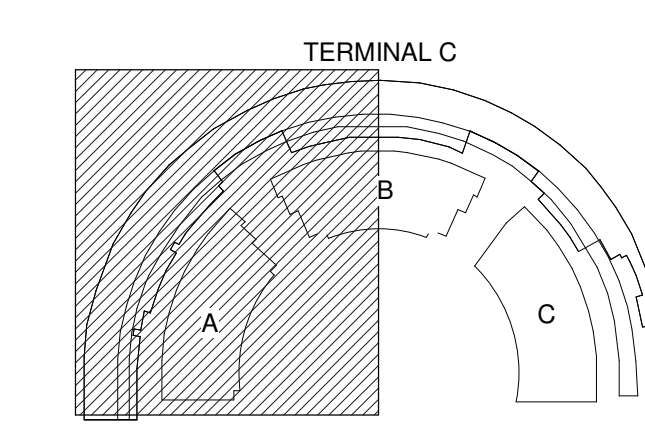
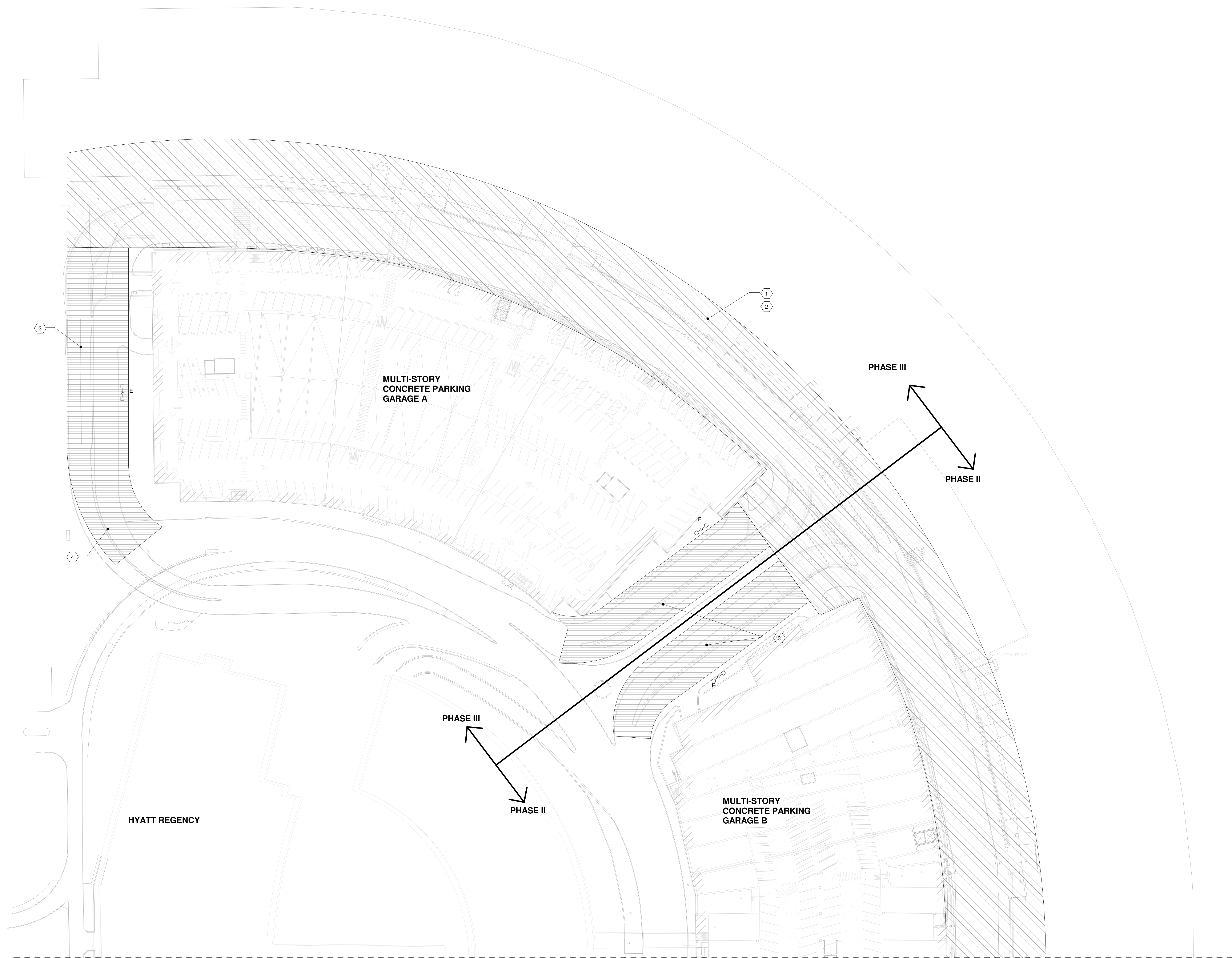

Permits:
B22-0021 - Terminal C Garage B
B22-0022 - Terminal C Garage A
B22-0023 - Terminal C Roadway

① UPPER ROADWAY - LIGHTING DEMOLITION - NORTH
1" = 40'-0"

MATCHLINE - SEE SHEET ED106-900R



2330 N INTERNATIONAL PARKWAY
DFW AIRPORT, TX 75261

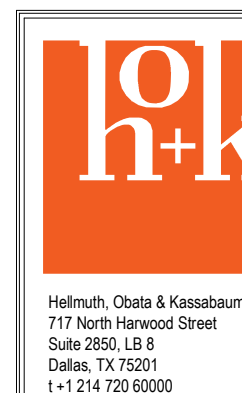
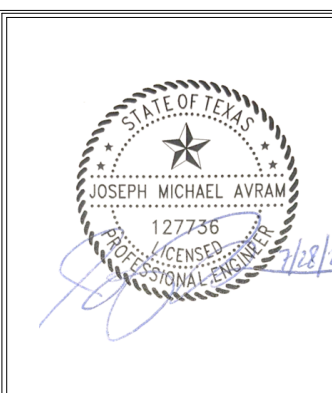

Primera

Heery, Obata & Kassabaum, Inc.
717 North Main Street
Suite 2050, LB #
Dallas, TX 75201
1-214-728-6000

Primera Engineers, LLC
5000 East Foothills
Suite 214
Coppell, TX 75011
1-972-899-9910

PROJECT NUMBER: TFD007

DRAWN BY: BMAY
APPROVED BY: RL/DLS
ISSUE DATE: 2022-07-28

**NOT FOR BID OR
CONSTRUCTION**

NO.	DATE	DESCRIPTION
2021-10-29	30% DESIGN	
2022-01-06	70% DESIGN	
2022-08-01	100% DESIGN	
2022-07-28	100% ISSUED FOR PERMIT (IFP)	

TERMINAL C GARAGE AND ROADWAYS
LIGHTING DEMOLITION - UPPER ROADWAY, NORTH

PROJECT NUMBER: TFD-007

PERMIT NUMBER: A21-1888

SHEET NUMBER
ED105-900R

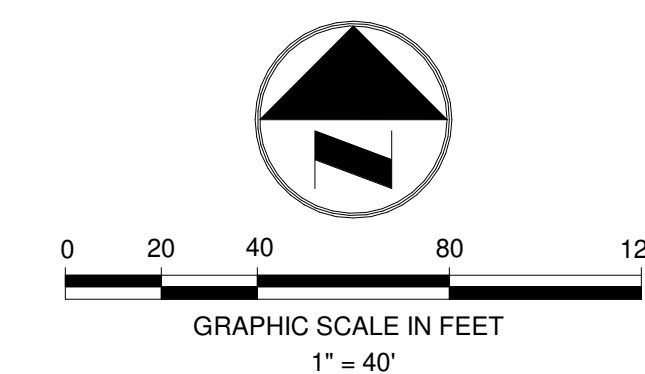

MATCHLINE - SEE SHEET ED105-900R

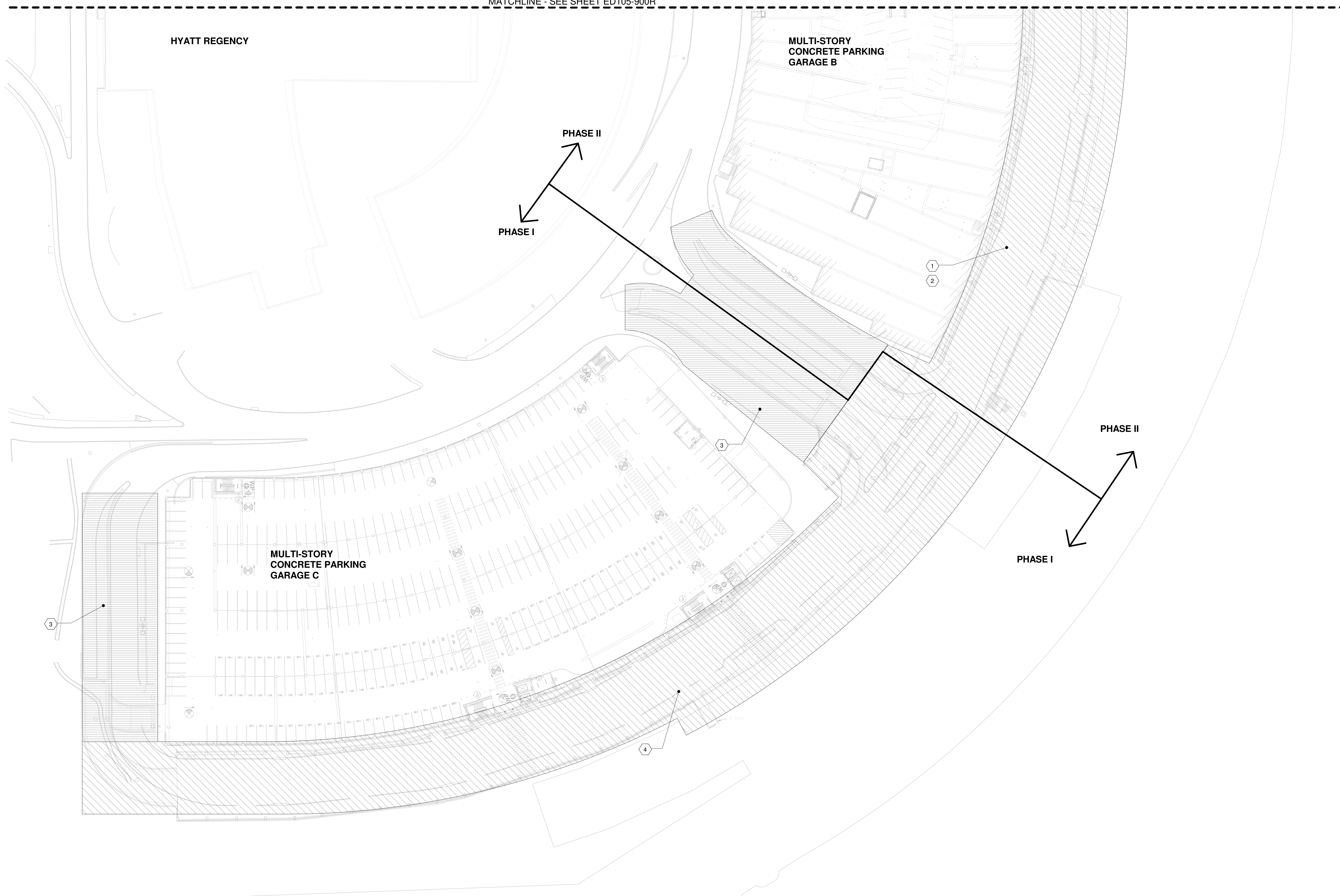

GENERAL NOTES:

1. REFER TO PHASING DEMARCATION LINES ON PLANS.
2. CARE SHALL BE TAKEN DURING DEMOLITION TO PRESERVE THE FOLLOWING: LARGE SHADE TREES, LARGE FLAG POLES, HIGHWAY SIGNAGE, REMAINING STRUCTURES, ETC.
3. ALL EXISTING HANDHOLES THAT ARE NOT COMPLETELY ABANDONED BY THIS WORK SHALL REMAIN AS IS.

KEYED NOTES:

- ① EXISTING HID LIGHTS AND POLES MOUNTED TO GARAGE STRUCTURE THAT SERVES THE ELEVATED ROADWAY SHALL BE REMOVED AND REPLACED IN FULL. WIRING AND CONDUIT FEEDING POLES SHALL BE REMOVED AND REPLACED IN FULL. TYPICAL FOR HATCHED AREA.
- ② EXISTING LIGHTS MOUNTED TO SHADE AND CONCRETE STRUCTURE ON TERMINAL BUILDING SIDE ARE NOT IN SCOPE. REFER TO TERMINAL RENOVATIONS. TYPICAL FOR HATCHED AREA.
- ③ EXISTING LED HIGHMAST LIGHTS SERVING THE RAMPS ARE TO REMAIN IN PLACE. CONDUIT AND WIRING SHALL BE PRESERVED. TYPICAL FOR HATCHED AREA.
- ④ ALL EXISTING LED ROADWAY LIGHTS SHALL BE SALVAGED AND HANDED OVER TO THE OWNER FOR MAINTENANCE STOCK.

NOTE TO REVIEWER:
PHASING PLANS WILL REQUIRE ADDITIONAL COORDINATION BETWEEN GARAGE AND TERMINAL WORK PRIOR TO 100% SUBMITTAL.

① UPPER ROADWAY - LIGHTING DEMOLITION - SOUTH
1" = 40'-0"

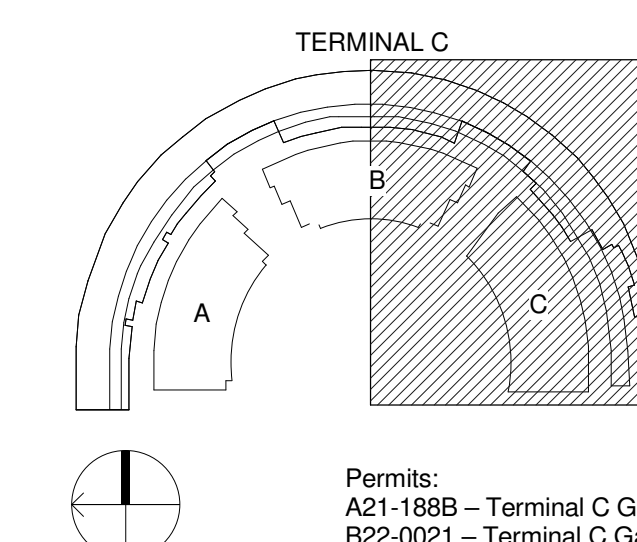

Permits:
A21-188B - Terminal C Garage C
B22-0021 - Terminal C Garage B
B22-0023 - Terminal C Roadway



2330 N INTERNATIONAL PARKWAY
DFW AIRPORT, TX 75261



Primera

Hobas, Clark & Koenigsmann, Inc.
777 North Memorial Street
Suite 2050, LB #
Dallas, TX 75201
1-214-722-6000

Primera Engineers, LLC
9000 Easton Trail
Suite 214
Coppell, TX 75011
1-972-899-9910

PROJECT NUMBER: TFD007

DRAWN BY: BMAY
APPROVED BY: RL/DS
ISSUE DATE: 2022-07-28

NOT FOR BID OR CONSTRUCTION

NO.	DATE	DESCRIPTION
2021-10-29	30% DESIGN	
2022-01-06	70% DESIGN	
2022-05-01	100% DESIGN	
2022-07-28	100% ISSUED FOR PERMIT (IFP)	

PROJECT NUMBER: TFD-007

TERMINAL C GARAGE AND ROADWAYS
LIGHTING DEMOLITION - UPPER ROADWAY, SOUTH

PERMIT NUMBER: A21-188B

SHEET NUMBER
ED106-900R

SCALE(S) AS NOTED ON THIS SHEET ARE BASED ON A FULL SIZE 30 X 42 SHEET.

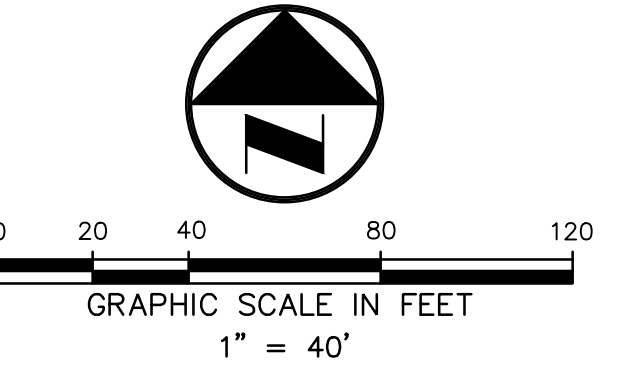

EXISTING LEGEND

- CRIADO CONTROL POINT
- IRON ROD FOUND
- BOLLARD
- GAS METER
- TRAFFIC SIGNAL LIGHT POLE
- TRAFFIC SIGNAL PULL BOX
- TRAFFIC SIGNAL CONTROL BOX
- TELECOM SERVICE BOX
- TELECOM PEDESTAL
- TELECOM MANHOLE
- CATV PEDESTAL
- CATV JUNCTION BOX
- CATV APPURTENANCE
- LIGHT POLE
- CATHODIC PROTECTION
- FLAG POLE
- GENERIC MANHOLE
- POWER POLE
- GUYWIRE
- ELECTRIC MANHOLE
- ELECTRIC PULL BOX
- ELECTRIC METER
- ELECTRIC BOX
- ELECTRIC RISER
- GROUND LIGHT SIGN
- GAS PUMP
- FUEL TANK VENT TREE
- BUSH
- WASTE WATER CLEANOUT
- WASTE WATER MANHOLE
- STORM DRAIN MANHOLE
- WATER VALVE
- IRRIGATION CONTROL VALVE
- SPRINKLER HEAD
- SPIGOT
- FIRE HYDRANT
- WATER METER
- OVERHEAD UTILITY
- OVERHEAD ELECTRIC

GENERAL NOTES

1. EQUIPMENT PAD PROVIDED BY DFW. ONCOR TO BE RESPONSIBLE FOR PROVIDING VISTA SWITCHGEARS AND TRANSFORMERS.
2. SEE SHEET E-002-900R FOR GENERAL ELECTRICAL NOTES.

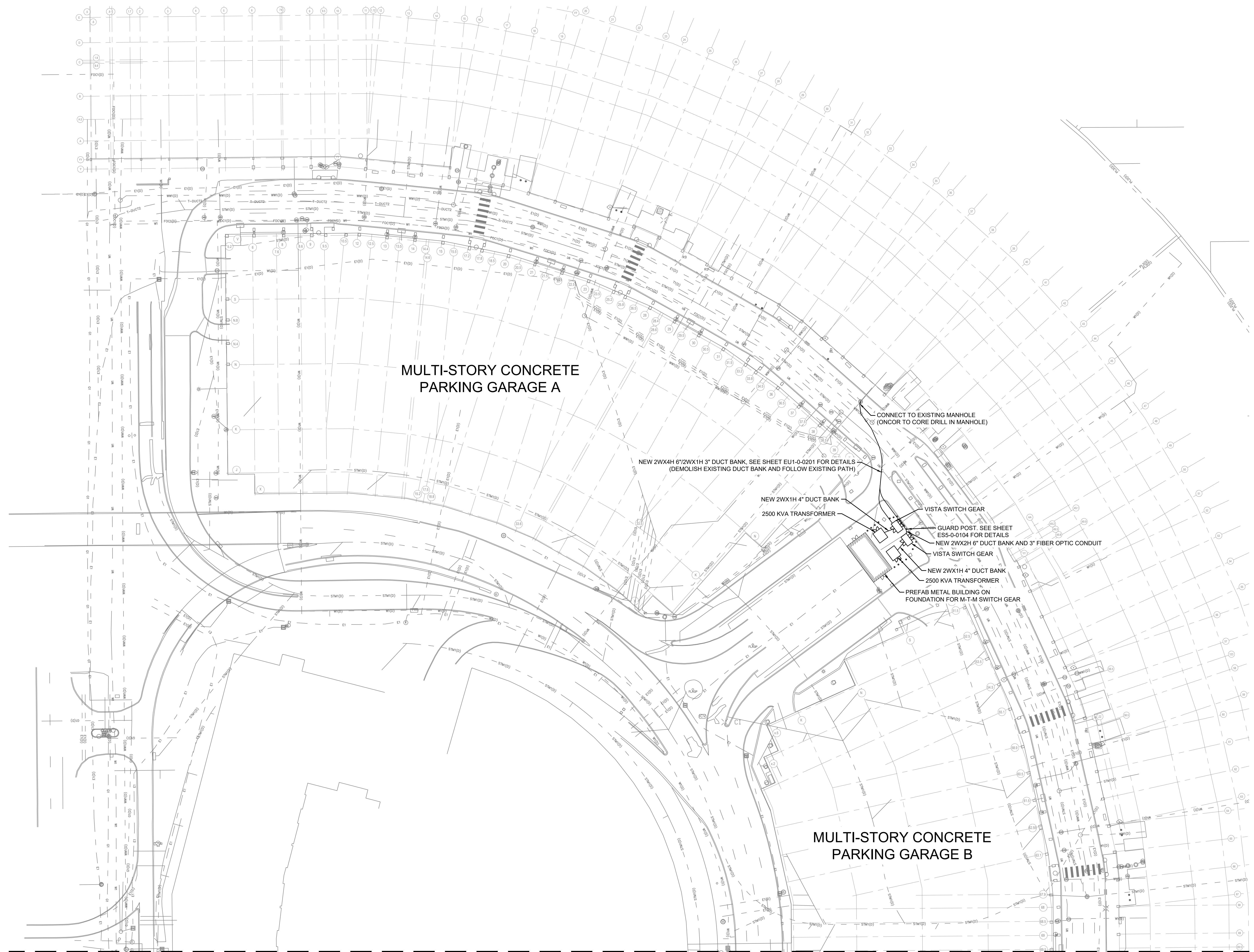

MATCHLINE - SEE SHEET ES102-900R

KEY PLAN

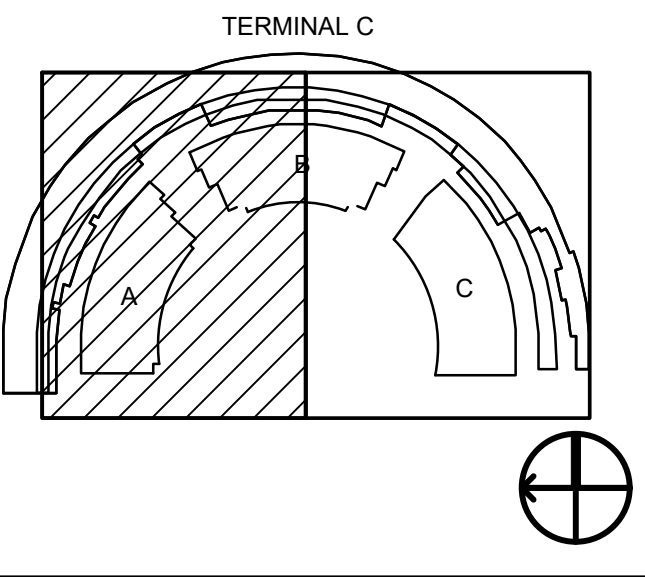

BORDER RELEASE DATE: October 16, 2021
01/20/2021 7:46:09 AM
C:\Users\michaelm\OneDrive\Documents\HOK\DALDFW\Intl Airport - CTA Expansion Program\Project Files\01_CTA - Terminal C Garages and Roadways\05_CE\01 - CAD\Sheets\ES101-900R.DWG



2330 N INTERNATIONAL PARKWAY
DFW AIRPORT, TX 75261



DRAWN BY: CTM
APPROVED BY: EM
ISSUE DATE: 2022-07-28
NOT FOR BID OR CONSTRUCTION

NO.	DATE	DESCRIPTION
0001	10-20-21	30% DESIGN
0002	01-09-22	50% DESIGN
0003	05-01-22	100% DESIGN
0004	07-28-22	100% REVISED FOR PERMIT (RFP)

TERMINAL C GARAGE & ROADWAYS
ELECTRICAL SITE PLAN, NORTH
PROJECT NUMBER: TFD-007
PERMIT NUMBER: A21-1888, B22-0023

SHEET NUMBER
ES101-900R

SCALE(S) AS NOTED ON THIS SHEET ARE BASED ON A FULL SIZE 30 X 42 SHEET.

MATCHLINE - SEE SHEET ES101-900R

MULTI-STORY CONCRETE
PARKING GARAGE B

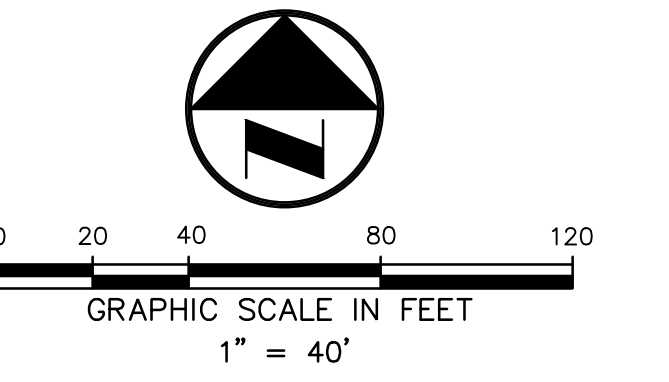

EXISTING LEGEND

- CRIADO CONTROL POINT
- IRON ROD FOUND
- BOLLARD
- GAS METER
- TRAFFIC SIGNAL LIGHT POLE
- TRAFFIC SIGNAL PULL BOX
- TRAFFIC SIGNAL CONTROL BOX
- TELECOM SERVICE BOX
- TELECOM PEDESTAL
- TELECOM MANHOLE
- CATV PEDESTAL
- CATV JUNCTION BOX
- CATV APPURTENANCE
- LIGHT POLE
- CATHODIC PROTECTION
- FLAG POLE
- GENERIC MANHOLE
- POWER POLE
- GUYWIRE
- ELECTRIC MANHOLE
- ELECTRIC PULL BOX
- ELECTRIC METER
- ELECTRIC BOX
- ELECTRIC RISER
- GROUND LIGHT
- SIGN
- GAS PUMP
- FUEL TANK VENT
- TREE
- BUSH
- WASTE WATER CLEANOUT
- WASTE WATER MANHOLE
- STORM DRAIN MANHOLE
- WATER VALVE
- IRRIGATION CONTROL VALVE
- SPRINKLER HEAD
- SPIGOT
- FIRE HYDRANT
- WATER METER
- OVERHEAD UTILITY
- OVERHEAD ELECTRIC

GENERAL NOTES

1. EQUIPMENT PAD PROVIDED BY DFW. ONCOR TO BE RESPONSIBLE FOR PROVIDING VISTA SWITCHGEARS AND TRANSFORMERS.
2. SEE SHEET E-002-900R FOR GENERAL ELECTRICAL NOTES.

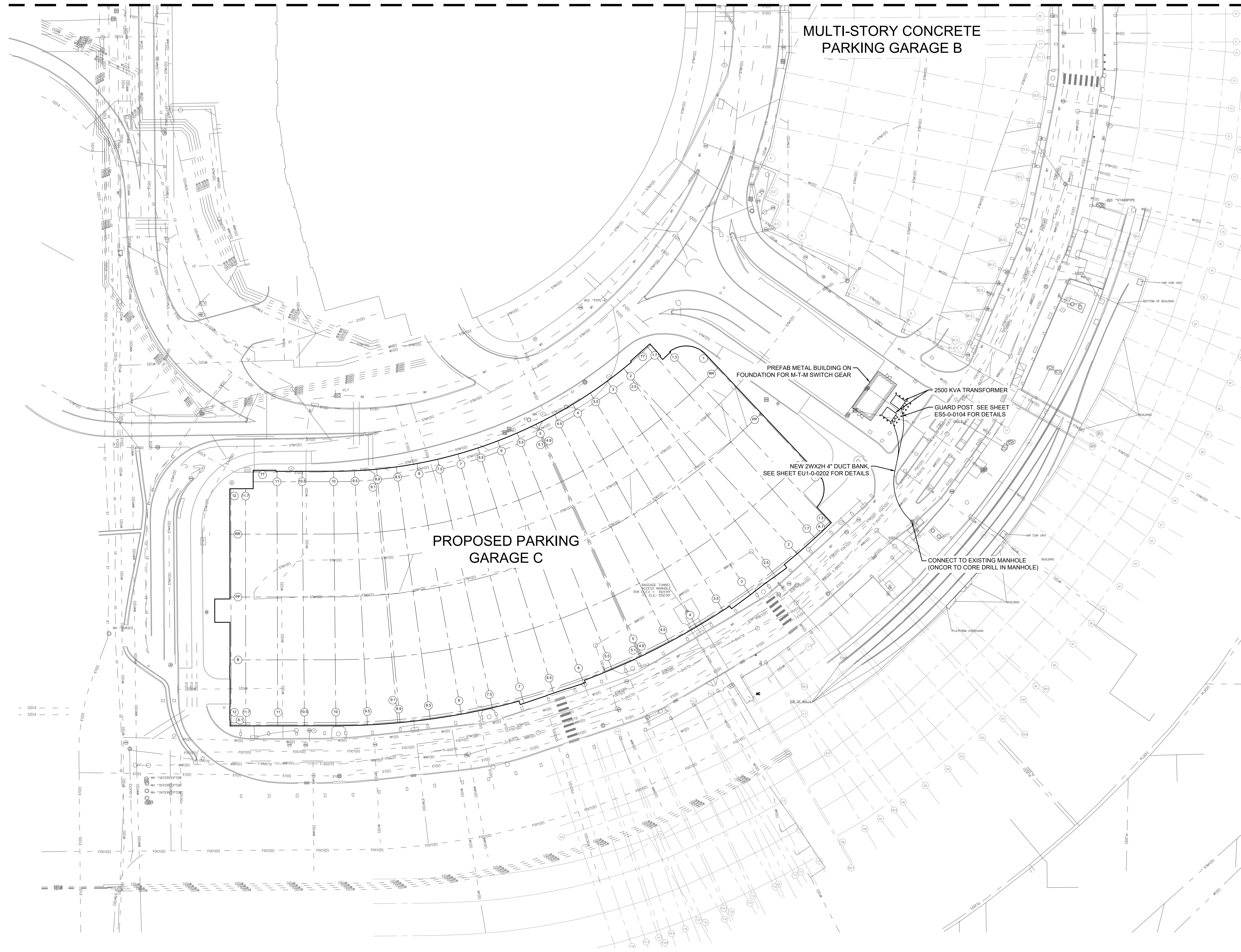

PROPOSED PARKING
GARAGE C

PREFAB METAL BUILDING ON
FOUNDATION FOR M-T-M SWITCH GEAR

2500 KVA TRANSFORMER

GUARD POST. SEE SHEET
ESS-0-0104 FOR DETAILS

NEW 2Wx2H 4\"/>

CONNECT TO EXISTING MANHOLE
(ONCOR TO CORE DRILL IN MANHOLE)

KEY PLAN

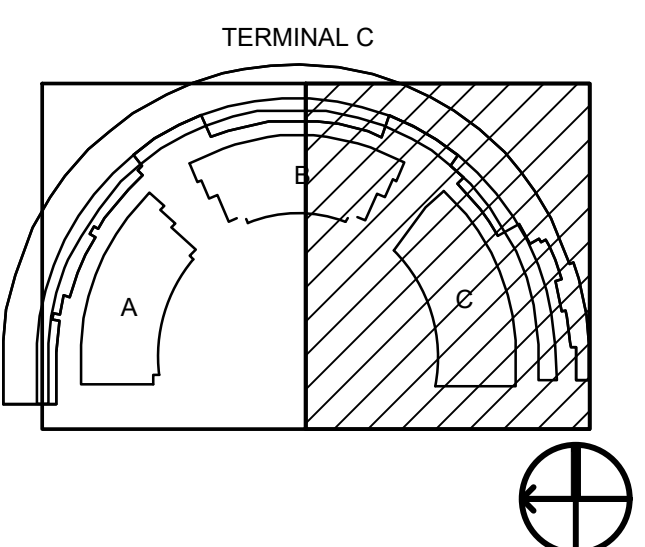

BORDER RELEASE DATE: October 16, 2021
01/20/2021 7:46:09 AM
C:\Users\michael.hok\OneDrive\Documents\DFW\Terminal C Expansion Program\Project Files\01_CTA - Terminal C Garages and Roadways\05_CE01 - CAD\Sheets\ES102-900R.DWG



DALLAS
FORT WORTH
INTERNATIONAL
AIRPORT



DRAWN BY: CTM
APPROVED BY: EM
ISSUE DATE: 2022-07-28
**NOT FOR BID OR
CONSTRUCTION**

NO.	DATE	DESCRIPTION
0001	01-20-21	30% DESIGN
0002	01-09-22	50% DESIGN
0003	05-01-22	100% DESIGN
0004	07-28-22	100% ISSUED FOR PERMIT (IFP)

PROJECT NUMBER: TFD-007

TERMINAL C GARAGE & ROADWAYS
ELECTRICAL SITE PLAN, SOUTH

PERMIT NUMBER: A21-1888, B22-0023

SHEET NUMBER
ES102-900R

SCALE(S) AS NOTED ON THIS SHEET ARE BASED ON A FULL SIZE 30 X 42 SHEET.

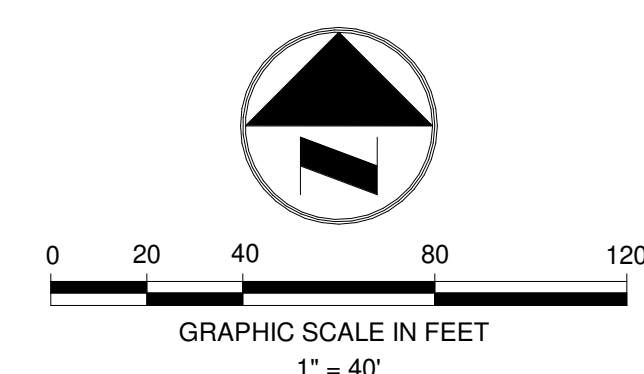

- NOTES:**
1. ALL WORK SHOWN ON THIS PLAN IS UNDER PHASE I SCOPE.
 2. REFER TO GARAGE A AND B DRAWINGS FOR CONDUIT ROUTING.
 3. THE ROUTING OF THE UNDERGROUND DUCT BANK AND FINAL ELEVATION SHALL BE COORDINATED WITH EXISTING UNDERGROUND UTILITIES.
 4. TEMPORARILY PACK PAVEMENT TO GET ROADWAYS BACK IN SERVICE AFTER THE DUCT BANK IS INSTALLED.

- KEYED NOTES:**
1. PROVIDE (2) UNDERGROUND CONCRETE ENCASED DUCT BANKS EACH WITH (8) 4" CONDUITS FOR POWER. PROVIDE IN EACH DUCT BANK (2) 2" CONDUITS FOR IT COMMUNICATIONS AND (1) 2" CONDUIT FOR FIRE ALARM COMMUNICATIONS. COORDINATE WITH RESPECTIVE GARAGE A CONSULTANT DRAWINGS FOR FURTHER ROUTING AND DUCT BANK LAYOUT. REFER TO DWG. EP201-900A.
 2. CONCRETE ENCASED DUCT BANK FOR GARAGE FEEDERS. STUB DAY ONE POWER CONDUITS INTO NEW ELECTRICAL ENCLOSURE DIRECTLY INTO THE MAIN SWITCHGEAR. SEE DRAWING ES3-0102 FOR SWITCHGEAR ELEVATION. STUB FUTURE POWER CONDUITS INTO THE CORNER IN THE MAIN ELECTRICAL ENCLOSURE 6" AFF. CAP AND LABEL. COORDINATE CONDUIT STUB UPS WITH THE SWITCHGEAR LOCATION AND ELEVATION. REFER TO GARAGE B & C DRAWINGS FOR CONDUIT ROUTING, NUMBER AND SIZE.
 3. COORDINATE WITH LOW VOLTAGE CONSULTANT AND FIRE ALARM CONSULTANT DRAWINGS FOR FURTHER ROUTING OF THE CONDUITS FOR LOW VOLTAGE AND FIRE ALARM COMMUNICATIONS.
 4. PROVIDE (2) UNDERGROUND CONCRETE ENCASED DUCT BANKS EACH WITH (4) 4" CONDUITS FOR POWER. PROVIDE IN EACH DUCT BANK (2) 2" CONDUITS FOR IT COMMUNICATIONS AND (1) 2" CONDUIT FOR FIRE ALARM COMMUNICATIONS. COORDINATE WITH RESPECTIVE GARAGE B CONSULTANT DRAWINGS FOR FURTHER ROUTING AND DUCT BANK LAYOUT. REFER TO DWG. EP201-900B.
 5. PROVIDE DEDICATED AND SEPARATE PULLBOXES FOR EACH: POWER DAY 1 AND FOR POWER FUTURE, LOW VOLTAGE AND FIRE ALARM. TOTAL 4 PULLBOXES.

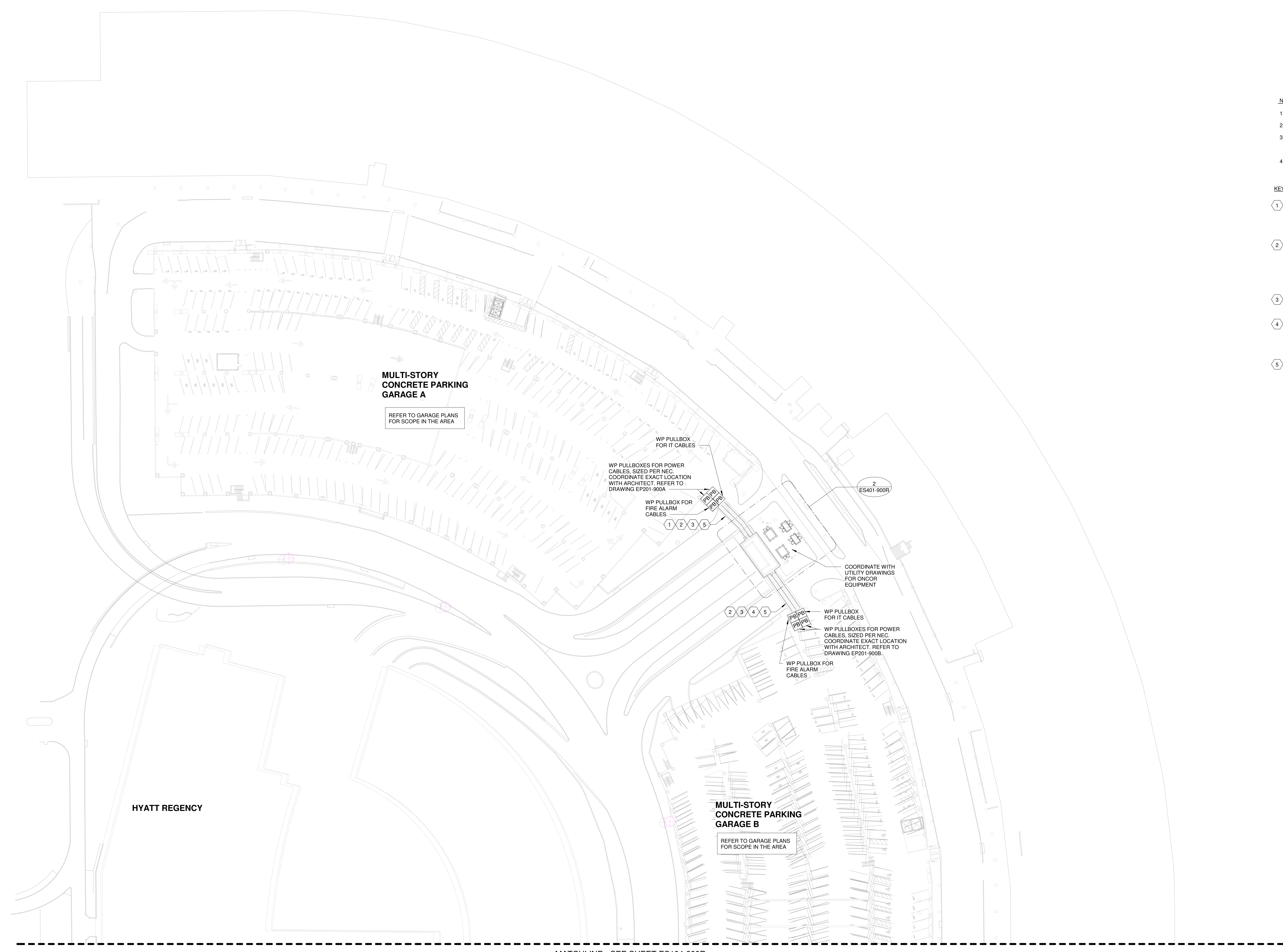

MATCHLINE - SEE SHEET ES104-900R

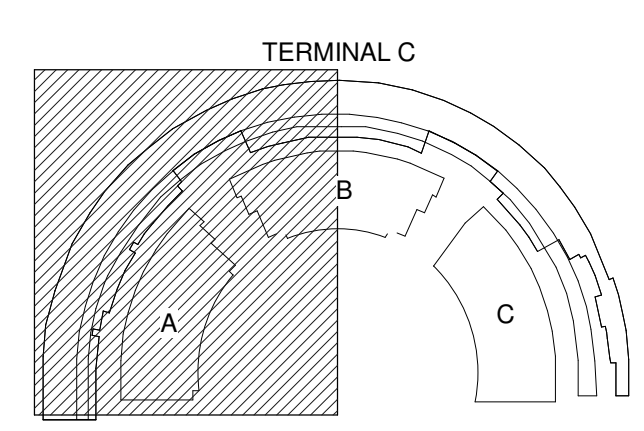

Permits:
A21-188B - Terminal C Garage C
B22-0021 - Terminal C Garage B
B22-0022 - Terminal C Garage A

1 LOWER ROADWAY - ELECTRICAL - NORTH
1" = 40'-0"



2330 N INTERNATIONAL PARKWAY
DFW AIRPORT, TX 75261

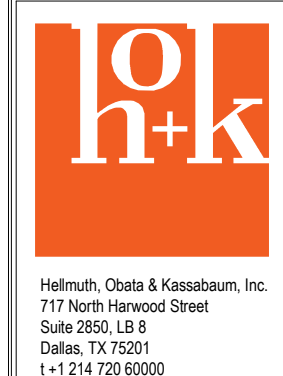
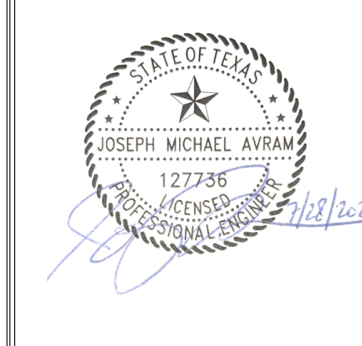

Primera

Joseph Michael Avram
777 North Westwood Drive
Suite 2050, LB #
Dallas, TX 75201
1-214-722-6000

Primera Engineers, LLC
5000 Easton Trail
Suite 214
Coppell, TX 75011
1-972-899-9910

PROJECT NUMBER: TFD007

DRAWN BY: BM/AY
APPROVED BY: RL/DS
ISSUE DATE: 2022-07-28

NOT FOR BID OR CONSTRUCTION

NO.	DATE	DESCRIPTION
2021-10-29	30% DESIGN	
2022-01-06	70% DESIGN	
2022-08-01	100% DESIGN	
2022-07-28	100% ISSUED FOR PERMIT (IFP)	

PROJECT NUMBER: TFD-007

TERMINAL C GARAGE AND ROADWAYS
ELECTRICAL NEW WORK - LOWER ROADWAY, NORTH

PERMIT NUMBER: A21-188B

SHEET NUMBER
ES103-900R

SCALE(S) AS NOTED ON THIS SHEET ARE BASED ON A FULL SIZE 30 X 42 SHEET.

MATCHLINE - SEE SHEET ES103-900R

HYATT REGENCY

MULTI-STORY CONCRETE PARKING GARAGE B
REFER TO GARAGE PLANS FOR SCOPE IN THE AREA

WP PULLBOXES FOR POWER CABLES, SIZED PER NEC, QUANTITY AS REQUIRED, COORDINATE EXACT LOCATION WITH ARCHITECT.

WP PULLBOX FOR IT CABLES

WP PULLBOX FOR FIRE ALARM CABLES

APPROXIMATE LOCATION OF PIPE

WP PULLBOXES FOR POWER CABLES, SIZED PER NEC, QUANTITY AS REQUIRED, COORDINATE EXACT LOCATION WITH ARCHITECT.

WP PULLBOX FOR FIRE ALARM CABLES

MULTI-STORY CONCRETE PARKING GARAGE C
REFER TO GARAGE PLANS FOR SCOPE IN THE AREA

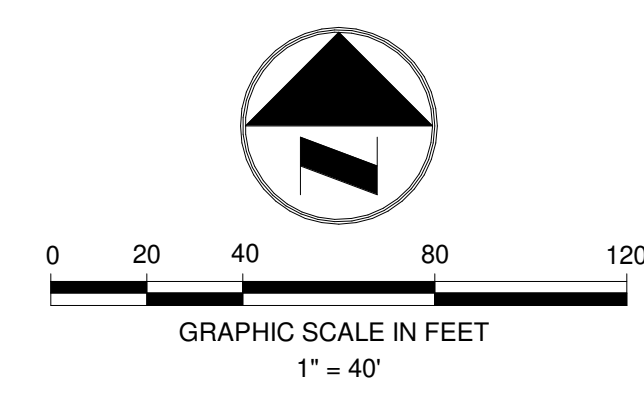

- NOTES:**
1. ALL WORK SHOWN ON THIS PLAN IS UNDER PHASE I SCOPE.
 2. REFER TO GARAGE C DRAWINGS FOR CONDUIT ROUTING.
 3. THE ROUTING OF THE UNDERGROUND DUCT BANK AND FINAL ELEVATION SHALL BE COORDINATED WITH EXISTING UNDERGROUND UTILITIES.
 4. TEMPORARILY PACK PAVEMENT TO GET THE ROADWAYS BACK IN SERVICE AFTER THE DUCT BANK IS INSTALLED.

- KEYED NOTES:**
1. PROVIDE (2) UNDERGROUND CONCRETE ENCASED DUCT BANKS, EACH CONSISTING OF (2) SETS OF (3) 4" CONDUITS FOR DAY ONE POWER AND (4) 4" SPARE CONDUITS FOR FUTURE POWER. PROVIDE (2) 2" CONDUITS FOR IT COMMUNICATIONS AND (1) 2" CONDUIT FOR FIRE ALARM COMMUNICATIONS. COORDINATE WITH RESPECTIVE CONSULTANT DRAWINGS FOR FURTHER CONDUIT ROUTING AND DUCT BANK LAYOUT. REFER TO DRAWING EP101-900C FOR DUCT BANK ROUTING.
 2. CONCRETE ENCASED DUCT BANK FOR GARAGE FEEDERS. STUB DAY ONE POWER CONDUITS INTO NEW ELECTRICAL ENCLOSURE DIRECTLY INTO THE MAIN SWITCHGEAR. SEE DRAWING ES3-0-0102 FOR SWITCHGEAR ELEVATION. STUB FUTURE POWER CONDUITS INTO THE CORNER IN THE MAIN ELECTRICAL ENCLOSURE # AFF. CAP AND LABEL. COORDINATE CONDUIT STUB UPS WITH THE SWITCHGEAR LOCATION AND ELEVATION. REFER TO GARAGE B & C DRAWINGS FOR CONDUIT ROUTING, NUMBER AND SIZE.
 3. COORDINATE WITH LOW VOLTAGE CONSULTANT AND FIRE ALARM CONSULTANT DRAWINGS FOR FURTHER ROUTING OF THE CONDUITS FOR LOW VOLTAGE AND FIRE ALARM COMMUNICATIONS.
 4. PROVIDE UNDERGROUND CONCRETE ENCASED DUCT BANK WITH (8) 4" CONDUITS FOR POWER, PROVIDE (2) 2" CONDUITS FOR IT COMMUNICATIONS AND (1) 2" CONDUIT FOR FIRE ALARM COMMUNICATIONS. COORDINATE WITH RESPECTIVE CONSULTANT DRAWINGS FOR FURTHER ROUTING AND DUCT BANK LAYOUT. REFER TO DWG. EP201-900B.
 5. PROVIDE DEDICATED AND SEPARATE PULLBOXES FOR EACH: POWER DAY 1 AND FOR POWER FUTURE, LOW VOLTAGE AND FIRE ALARM, TOTAL 4 PULLBOXES.

① LOWER ROADWAY - ELECTRICAL - SOUTH
1" = 40'-0"

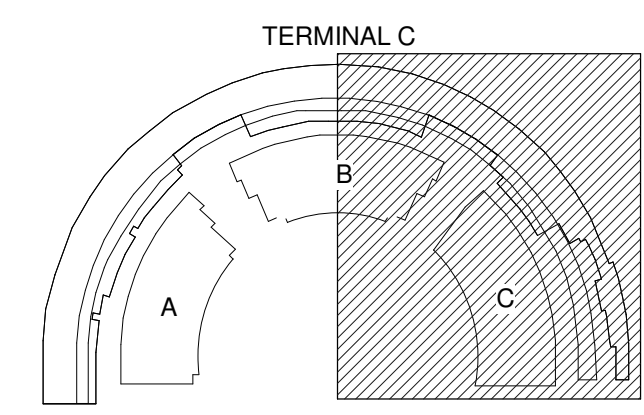

Permits:
A21-1888 - Terminal C Garage C
B22-0021 - Terminal C Garage B
B22-0023 - Terminal C Roadway



2330 N INTERNATIONAL PARKWAY
DFW AIRPORT, TX 75261



Primera

Joseph Michael Avram
12736
Dallas, TX 75201
1-214-722-6000

Primera Engineers, Ltd.
3000 Easton
Suite 214
Coppell, TX 75011
1-972-899-9910

PROJECT NUMBER: TFD007

DRAWN BY: BMAY
APPROVED BY: RL/DS
ISSUE DATE: 2022-07-28

NOT FOR BID OR CONSTRUCTION

NO.	DATE	DESCRIPTION
2021-10-29	30% DESIGN	
2022-01-06	70% DESIGN	
2022-08-01	100% DESIGN	
2022-07-28	100% ISSUED FOR PERMIT (IFP)	

PROJECT NUMBER: TFD-007

TERMINAL C GARAGE AND ROADWAYS
ELECTRICAL NEW WORK - LOWER ROADWAY, SOUTH

PERMIT NUMBER: A21-1888

SHEET NUMBER
ES104-900R

SCALE(S) AS NOTED ON THIS SHEET ARE BASED ON A FULL SIZE 30 X 42 SHEET.

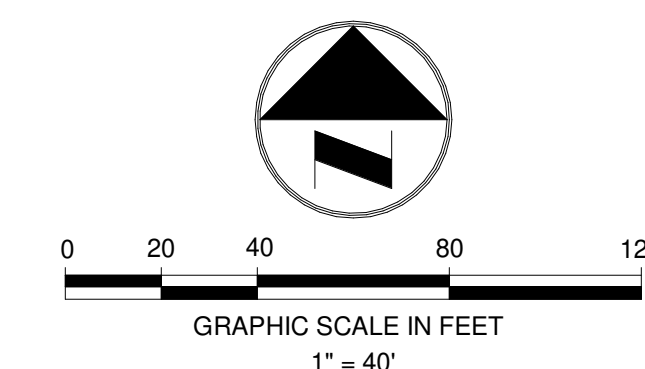

GENERAL NOTES:

- ALL LIGHTING CIRCUITS FOR PHASE III SHALL BE FED FROM GARAGE A. UNO. NORMAL LIGHTING WILL BE FED FROM FIRST FLOOR POWER PANEL "A-DP-A-107" AND THIRD FLOOR PANEL "A-DP-C-307" (CCTS. A2-42). EMERGENCY LIGHTING WILL BE FED FROM FIRST FLOOR INVERTER "INVB1" (CCTS. EM-1-2).
- ALL LIGHTING CIRCUITS FOR PHASE II SHALL BE FED FROM GARAGE B. UNO. NORMAL LIGHTING WILL BE FED FROM FIRST FLOOR POWER PANEL "B-DP-A-104" AND THIRD FLOOR PANEL "B-DP-C-306" (CCTS. B2-42). EMERGENCY LIGHTING WILL BE FED FROM FIRST FLOOR INVERTER "INVB2" (CCTS. EM-1-2).
- NOT USED.
- MINIMUM CONDUIT SIZE IS 3/4".
- WIRING SIZE IS #10 AWG.
- MINIMUM HANDHOLE SIZE IS 24"x24".
- EM CIRCUITS SHALL HAVE DEDICATED WIRING AND CONDUIT. PHYSICALLY SEPARATE FROM THE NORMAL POWER DISTRIBUTION.
- ALL SITE LIGHTING SHALL BE BROUGHT TO PULLBOXES AT ENTRANCE TO GARAGE STRUCTURE. FROM THE PULLBOX TO THE ELECTRICAL ROOM. REFER TO GARAGE PLANS FOR EXACT ROUTING.
- LIGHTING CONTROL COMPONENTS FOR PHASE III SHALL BE HOUSED IN GARAGE A ELECTRICAL ROOM.
- LIGHTING CONTROL COMPONENTS FOR PHASE II SHALL BE HOUSED IN GARAGE B ELECTRICAL ROOM.

KEYED NOTES:

- COORDINATE LOCATION OF LIGHT WITH EXISTING LARGE GROWTH TREES.
- NOT USED
- EXISTING HID FLOODS FOR ROADWAY SIGNAGE SHALL BE REMOVED AND REPLACED IN FULL. CONDUIT AND WIRING SHALL BE REMOVED AND REPLACED IN FULL.
- EXISTING DOWNLIGHTS EMBEDDED IN OVERPASS SHALL BE RETROFITTED WITH LED RETROFIT KITS. ASSUME (6) FOR PRICING
- EXISTING WALL PACK WALL MOUNTED ON COLUMN LOCATED UNDERNEATH RAMP.
- RELOCATION REQUIRED. COORDINATE THE RELOCATION OF EXISTING WALL PACK WITH NEW ELECTRICAL ENCLOSURE.
- SURFACE MOUNT LIGHTS AND CONDUIT ON EXISTING STRUCTURES AT THIS LOCATION.
- CONCRETE ENCASE ALL CONDUITS PASSING BELOW ROADWAYS, DRIVE PATHS, AND PARKING AREAS. EXTEND ENCASEMENT 3' PAST CURBS ON EITHER SIDE.

NOTE TO REVIEWER:
PHASING PLANS WILL REQUIRE ADDITIONAL COORDINATION BETWEEN GARAGE AND TERMINAL WORK PRIOR TO 100% SUBMITTAL.

FEEDER SCHEDULE				
TAG	FEEDER SIZE	CONDUIT	MOUNTING	SPARES
A	(2) #10s, #10 GRD	1" C	SURFACE	-
B	(3) #10s, #10 GRD	1" C	SURFACE	-
C	(4) #10s, #10 GRD	1" C	SURFACE	-
D	(5) #10s, #10 GRD	1" C	SURFACE	-
E	(6) #10s, #10 GRD	1" C	SURFACE	-
F	(9) #10s, #10 GRD	1" C	SURFACE	-
G	(2) #6s, #8 GRD	1" C	SURFACE / BELOW GRADE	-
H	(2) #6s, (2) #10s, #8 GRD	1" C	SURFACE / BELOW GRADE	1" C
I	(4) #6s, #8 GRD	1-1/2" C	SURFACE / BELOW GRADE	1-1/2" C

*based on XHHW and RGS

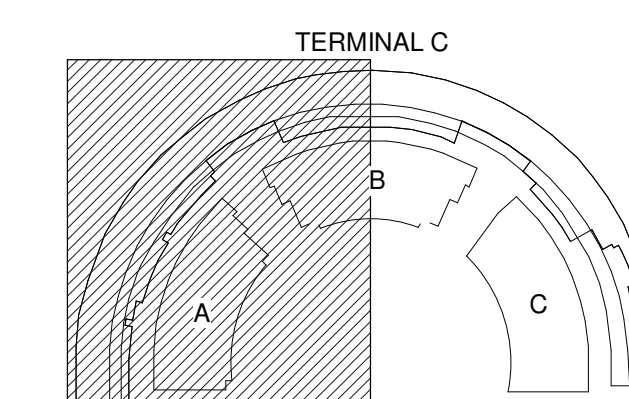

Permits:
A21-1888 - Terminal C Garage C
B22-0021 - Terminal C Garage B
B22-0022 - Terminal C Garage A
B22-0023 - Terminal C Roadway

PERMIT NUMBER: A21-1888

SHEET NUMBER
ES105-900R

SCALE(S) AS NOTED ON THIS SHEET ARE BASED ON A FULL SIZE 30 X 42 SHEET.

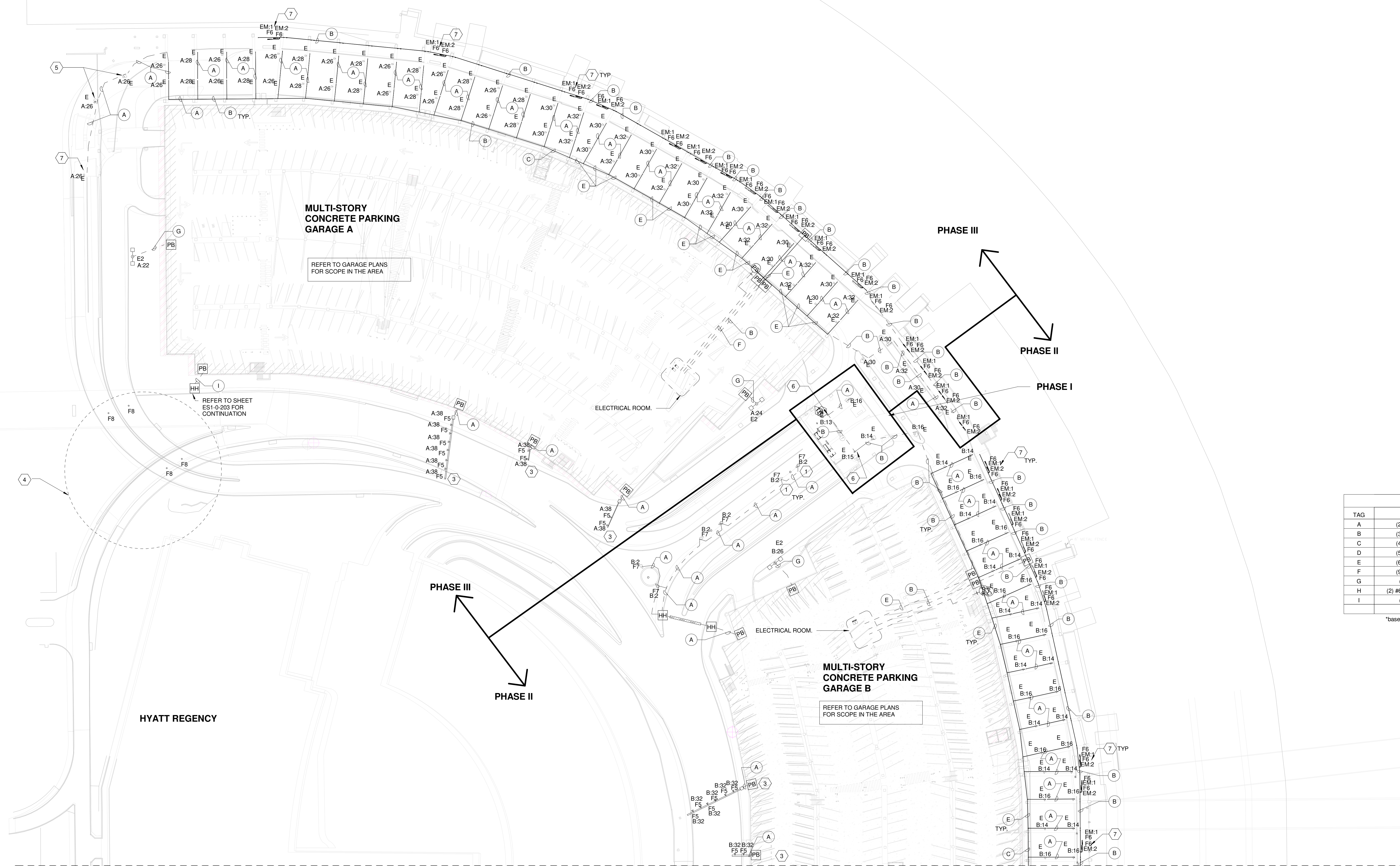

1 LOWER ROADWAY - LIGHTING - NORTH
1" = 40'-0"

MATCHLINE - SEE SHEET ES106-900R



2330 N INTERNATIONAL PARKWAY
DFW AIRPORT, TX 75261



Primera

Joseph Michael Avram
717 North Meadows Drive
Suite 2050, LB #
Dallas, TX 75201
1-214-722-6000

Primera Engineers, LLC
3000 East Fort
Coppell, TX 75011
1-972-999-9910

PROJECT NUMBER: TFD007

DRAWN BY: BMAY
APPROVED BY: RL/DLS
ISSUE DATE: 2022-07-28

NOT FOR BID OR CONSTRUCTION

NO.	DATE	DESCRIPTION
2021-10-29	30% DESIGN	
2022-01-06	70% DESIGN	
2022-08-01	100% DESIGN	
2022-07-28	100% ISSUED FOR PERMIT (IFP)	

PROJECT NUMBER: TFD-007

TERMINAL C GARAGE AND ROADWAYS
LIGHTING NEW WORK - LOWER ROADWAY, NORTH

MATCHLINE - SEE SHEET ES105-900R

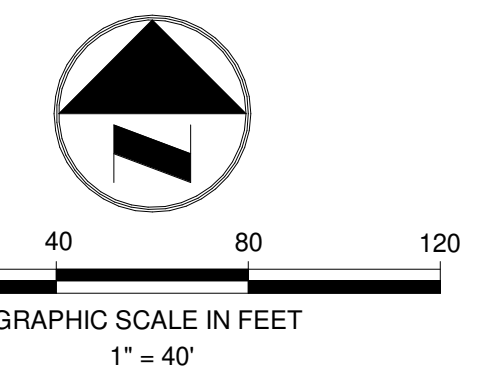

HYATT REGENCY

MULTI-STORY CONCRETE PARKING GARAGE B

REFER TO GARAGE PLANS FOR SCOPE IN THE AREA

PHASE II

PHASE I

MULTI-STORY CONCRETE PARKING GARAGE C

REFER TO GARAGE PLANS FOR SCOPE IN THE AREA

ELECTRICAL ROOM

GENERAL NOTES:

- ALL LIGHTING CIRCUITS FOR PHASE I SHALL BE FED FROM GARAGE C. UNO. NORMAL LIGHTING WILL BE FED FROM FIRST FLOOR POWER PANEL "C-1B11" (CCTS. C-2-42); EMERGENCY LIGHTING WILL BE FED FROM FIRST FLOOR INVERTER "INVCB" (CCTS. EM-1-2)
- ALL LIGHTING CIRCUITS FOR PHASE II SHALL BE FED FROM GARAGE B. UNO. NORMAL LIGHTING WILL BE FED FROM FIRST FLOOR POWER PANEL "B-DP-A-104" AND THIRD FLOOR PANEL "B-DP-C-306" (CCTS. B-2-42); EMERGENCY LIGHTING WILL BE FED FROM FIRST FLOOR INVERTER "INVCB" (CCTS. EM-1-2)
- NOT USED.
- MINIMUM CONDUIT SIZE IS 3/4".
- WIRING SIZE IS #10 AWG.
- MINIMUM HANDHOLE SIZE IS 24"x24"
- EM CIRCUITS SHALL HAVE DEDICATED WIRING AND CONDUIT, PHYSICALLY SEPARATE FROM THE NORMAL POWER DISTRIBUTION.
- ALL SITE LIGHTING SHALL BE BROUGHT TO PULLBOXES AT ENTRANCE TO GARAGE STRUCTURE, FROM THE PULLBOX TO THE ELECTRICAL ROOM, REFER TO GARAGE PLANS FOR EXACT ROUTING.
- LIGHTING CONTROL COMPONENTS FOR PHASE III SHALL BE HOUSED IN GARAGE A ELECTRICAL ROOM.
- LIGHTING CONTROL COMPONENTS FOR PHASE II SHALL BE HOUSED IN GARAGE B ELECTRICAL ROOM.

KEYED NOTES:

- COORDINATE LOCATION OF LIGHT WITH EXISTING LARGE GROWTH TREES.
- EXISTING HID FLOORS FOR ROADWAY SIGNAGE SHALL BE REMOVED AND REPLACED IN FULL. CONDUIT AND WIRING SHALL REMAIN AND BE REUSED.
- EXISTING HID FLOORS FOR ROADWAY SIGNAGE SHALL BE REMOVED AND REPLACED IN FULL. CONDUIT AND WIRING SHALL BE REMOVED AND REPLACED IN FULL.
- RELOCATION REQUIRED. COORDINATE THE RELOCATION OF EXISTING WALL PALK WITH NEW ELECTRICAL ENCLOSURE.
- CONCRETE ENCASE ALL CONDUITS PASSING BELOW ROADWAYS, DRIVE PATHS, AND PARKING AREAS. EXTEND ENCASEMENT 3' PAST CURBS ON EITHER SIDE.
- SURFACE MOUNT LIGHTS AND CONDUIT ON EXISTING STRUCTURES AT THIS LOCATION.

NOTE TO REVIEWER:
PHASING PLANS WILL REQUIRE ADDITIONAL COORDINATION BETWEEN GARAGE AND TERMINAL WORK PRIOR TO 100% SUBMITTAL.

FEEDER SCHEDULE				
TAG	FEEDER SIZE	CONDUIT	MOUNTING	SPARES
A	(2) #10's, #10 GRD	1" C	SURFACE	-
B	(3) #10's, #10 GRD	1" C	SURFACE	-
C	(4) #10's, #10 GRD	1" C	SURFACE	-
D	(5) #10's, #10 GRD	1" C	SURFACE	-
E	(6) #10's, #10 GRD	1" C	SURFACE	-
F	(8) #10's, #10 GRD	1" C	SURFACE	-
G	(2) #6's, #8 GRD	1" C	SURFACE / BELOW GRADE	-
H	(2) #6's, (2) #10's, #8 GRD	1" C	SURFACE / BELOW GRADE	1-1" C
I	(4) #6's, #8 GRD	1-1/2" C	SURFACE / BELOW GRADE	1-1/2" C

*based on XHHW and RGS

1 LOWER ROADWAY - LIGHTING - SOUTH
1" = 40'-0"

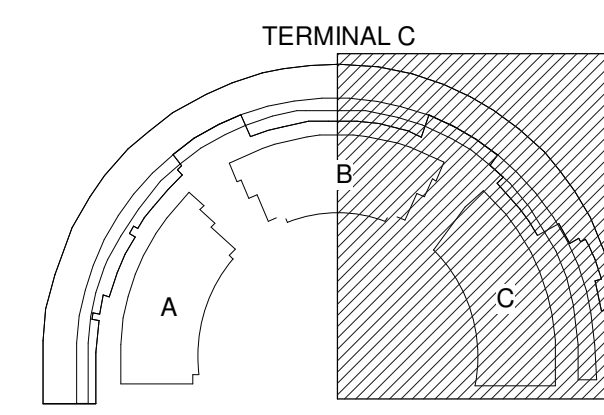

Permits:
A21-188B - Terminal C Garage C
B22-0021 - Terminal C Garage B
B22-0023 - Terminal C Roadway



2330 N INTERNATIONAL PARKWAY
DFW AIRPORT, TX 75261

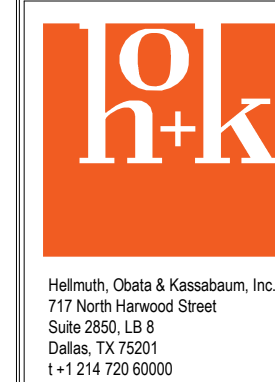

Primera

Primera Engineers, LLC
12736
Dallas, TX 75241
1-214-728-6000

DRAWN BY: BMAY
APPROVED BY: RLDS
ISSUE DATE: 2022-07-28

NOT FOR BID OR CONSTRUCTION

NO.	DATE	DESCRIPTION
2021-10-29	30% DESIGN	
2022-01-06	70% DESIGN	
2022-08-01	100% DESIGN	
2022-07-28	100% ISSUED FOR PERMIT (IFP)	

PROJECT NUMBER: TFD-007

TERMINAL C GARAGE AND ROADWAYS
LIGHTING NEW WORK - LOWER ROADWAY, SOUTH

PERMIT NUMBER: A21-188B

SHEET NUMBER
ES106-900R

SCALE(S) AS NOTED ON THIS SHEET ARE BASED ON A FULL SIZE 30 X 42 SHEET.

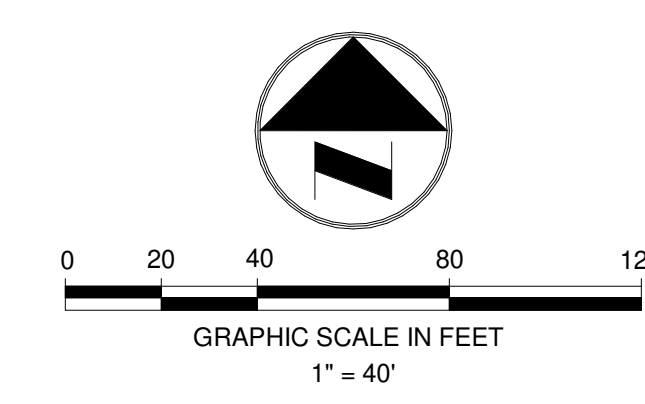

- GENERAL NOTES:**
- ALL LIGHTING CIRCUITS FOR PHASE II SHALL BE FED FROM GARAGE A. UNO. NORMAL LIGHTING WILL BE FED FROM FIRST FLOOR POWER PANEL "A-1BH1" (CCTS. A-2-42).
 - ALL LIGHTING CIRCUITS FOR PHASE II SHALL BE FED FROM GARAGE B. UNO. NORMAL LIGHTING WILL BE FED FROM FIRST FLOOR POWER PANEL "B-1BH1" (CCTS. B-2-42).
 - MINIMUM CONDUIT SIZE IS 3/4" C.
 - MINIMUM WIRING SIZE IS #10 AWG.
 - LIGHTING CONTROL COMPONENTS FOR PHASE III SHALL BE HOUSED IN GARAGE A ELECTRICAL ROOM.
 - LIGHTING CONTROL COMPONENTS FOR PHASE II SHALL BE HOUSED IN GARAGE B ELECTRICAL ROOM.
 - REFER TO GARAGE PLANS FOR ANY PARKING LIGHTING THAT MAY BE MOUNTED TO LIGHT POLES HEREIN.
 - COORDINATE INSTALLATION OF LIGHT POLES ON GARAGES A AND B WITH EXISTING LIGHTNING PROTECTION SYSTEM. WHERE CONFLICTS ARISE, ADJUST LIGHTNING PROTECTION CABLES AROUND NEW POLES.

- KEYED NOTES:**
- LIGHT POLE SHALL BE MOUNTED ON EXISTING GARAGE A STRUCTURE. STRUCTURAL ENGINEER TO DETERMINE PHYSICAL TIE-IN CONDITIONS AND STRUCTURAL LOADINGS. LIGHT FIXTURE SHALL BE INSTALLED AT 5' ABOVE ELEVATED ROAD FINISHED GRADE.
 - LIGHT POLE SHALL BE MOUNTED ON EXISTING GARAGE B STRUCTURE. STRUCTURAL ENGINEER TO DETERMINE PHYSICAL TIE-IN CONDITIONS AND STRUCTURAL LOADINGS. LIGHT FIXTURE SHALL BE INSTALLED AT 5' ABOVE ELEVATED ROAD FINISHED GRADE.
 - EXISTING LIGHTS MOUNTED TO SHADE AND CONCRETE STRUCTURES ON TERMINAL BUILDING SIDE ARE NOT IN SCOPE. REFER TO TERMINAL RENOVATIONS.
 - ROADWAY LIGHTING SHALL COORDINATE WITH FUTURE TERMINAL CANOPY DESIGN IN THIS LOCATION.
 - EXISTING DOWNLIGHTS EMBEDDED IN OVERPASS SHALL BE RETROFITTED WITH LED RETROFIT KITS.
 - CONCRETE ENCASE ALL CONDUITS PASSING BELOW ROADWAYS, DRIVE PATHS, AND PARKING AREAS. EXTEND ENCASEMENT 3' PAST CURBS ON EITHER SIDE.
 - SURFACE MOUNT LIGHTS AND CONDUIT ON EXISTING STRUCTURES AT THIS LOCATION.
 - RE-USE EXISTING POLE LOCATION AND ANCHOR BOLTS. SEE DETAIL 2-ESS03-900R.

NOTE TO REVIEWER:
PHASING PLANS WILL REQUIRE ADDITIONAL COORDINATION BETWEEN GARAGE AND TERMINAL WORK PRIOR TO 100% SUBMITTAL.

FEEDER SCHEDULE				
TAG	FEEDER SIZE	CONDUIT	MOUNTING	SPARES
A	(2) #10's, #10 GRD	1" C	SURFACE	-
B	(3) #10's, #10 GRD	1" C	SURFACE	-
C	(4) #10's, #10 GRD	1" C	SURFACE	-
D	(5) #10's, #10 GRD	1" C	SURFACE	-
E	(6) #10's, #10 GRD	1" C	SURFACE	-
F	(9) #10's, #10 GRD	1" C	SURFACE	-
G	(2) #6's, #8 GRD	1" C	SURFACE / BELOW GRADE	-
H	(2) #6's, (2) #10's, #8 GRD	1" C	SURFACE / BELOW GRADE	1" C
I	(4) #6's, #8 GRD	1-1/2" C	SURFACE / BELOW GRADE	1-1/2" C

*based on XHHW and RGS

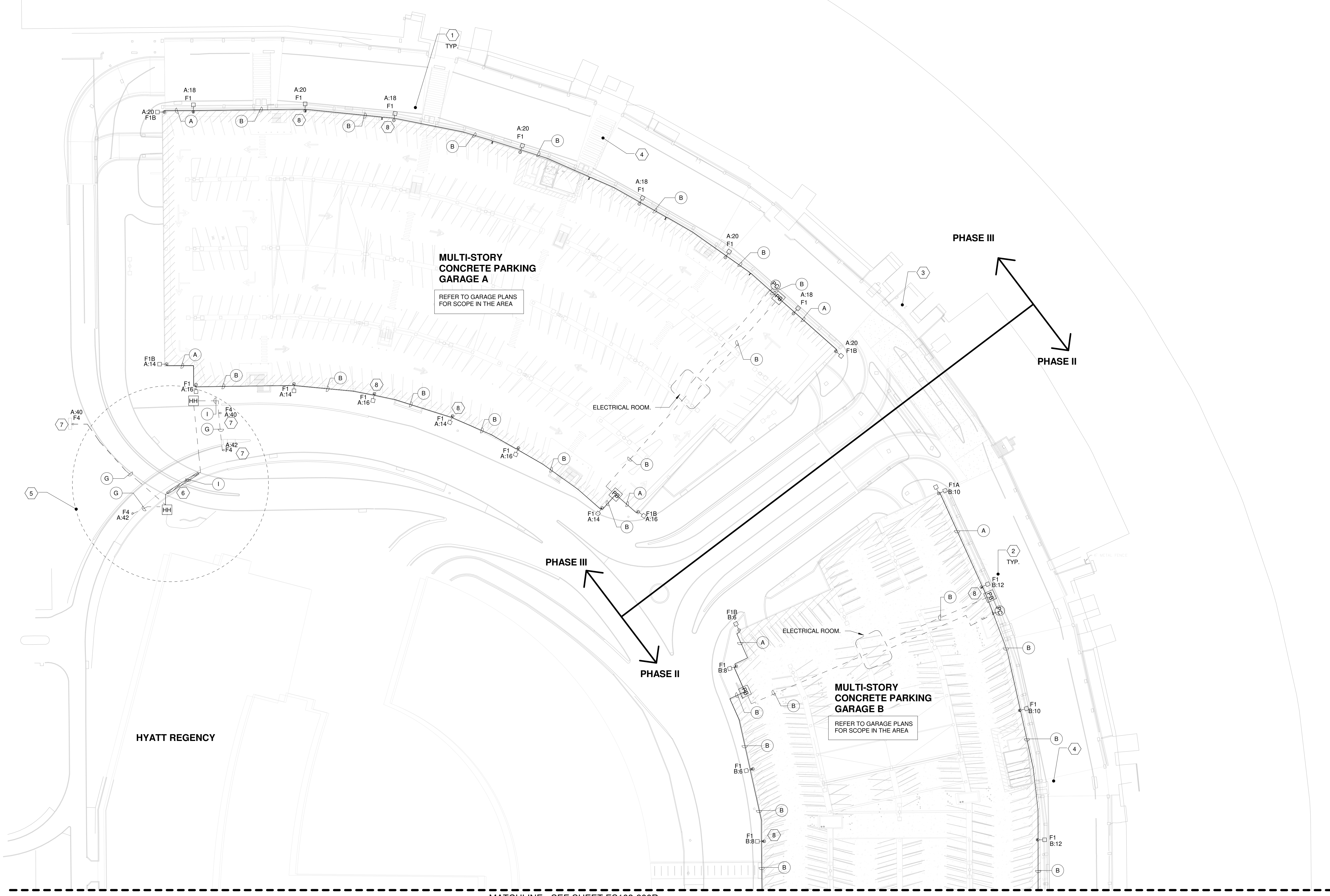

MATCHLINE - SEE SHEET ES108-900R

1 UPPER ROADWAY - LIGHTING - NORTH
1" = 40'-0"

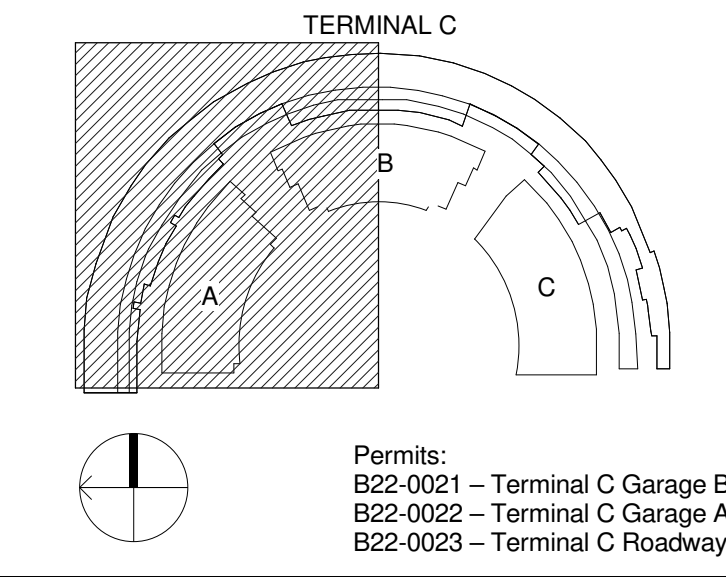

2330 N INTERNATIONAL PARKWAY
DFW AIRPORT, TX 75261

PROJECT NUMBER: TFD007

DRAWN BY: BMAY
APPROVED BY: RL/DLS
ISSUE DATE: 2022-07-28

NOT FOR BID OR CONSTRUCTION

NO.	DATE	DESCRIPTION
2021-10-29	30% DESIGN	
2022-01-06	70% DESIGN	
2022-08-01	100% DESIGN	
2022-07-28	100% ISSUED FOR PERMIT (IFP)	

TERMINAL C GARAGE AND ROADWAYS
LIGHTING NEW WORK - UPPER ROADWAY, NORTH

PROJECT NUMBER: TFD-007

PERMIT NUMBER: A21-1888

SHEET NUMBER
ES107-900R

SCALE(S) AS NOTED ON THIS SHEET ARE BASED ON A FULL SIZE 30 X 42 SHEET.

MATCHLINE - SEE SHEET ES107-900R

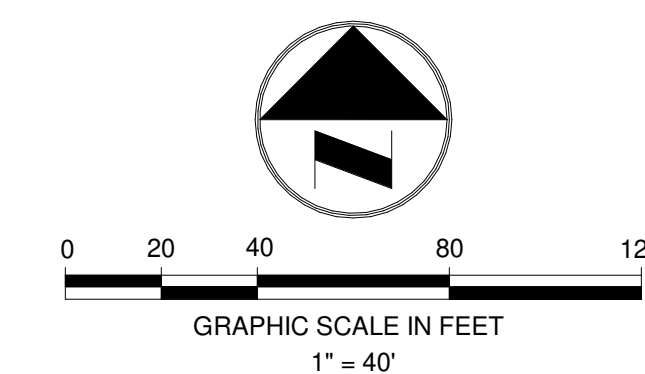

HYATT REGENCY

MULTI-STORY CONCRETE PARKING GARAGE B
REFER TO GARAGE PLANS FOR SCOPE IN THE AREA

MULTI-STORY CONCRETE PARKING GARAGE C
REFER TO GARAGE PLANS FOR SCOPE IN THE AREA

ELECTRICAL ROOM

PHASE I
PHASE II

PHASE I
PHASE II

GENERAL NOTES:

- ALL LIGHTING CIRCUITS FOR PHASE I SHALL BE FED FROM GARAGE C. UNO. NORMAL LIGHTING WILL BE FED FROM FIRST FLOOR POWER PANEL "C-18H1" (CCTS. C-2-45).
- ALL LIGHTING CIRCUITS FOR PHASE II SHALL BE FED FROM GARAGE B. UNO. NORMAL LIGHTING WILL BE FED FROM FIRST FLOOR POWER PANEL "B-18H1" (CCTS. B-2-42).
- MINIMUM CONDUIT SIZE IS 3/4" C.
- MINIMUM WIRING SIZE IS #10 AWG.
- LIGHTING CONTROL COMPONENTS FOR PHASE I SHALL BE HOUSED IN GARAGE C ELECTRICAL ROOM.
- LIGHTING CONTROL COMPONENTS FOR PHASE II SHALL BE HOUSED IN GARAGE B ELECTRICAL ROOM.
- REFER TO GARAGE PLANS FOR ANY PARKING LIGHTING THAT MAY BE MOUNTED TO LIGHT POLES HEREIN.
- COORDINATE INSTALLATION OF LIGHT POLES ON GARAGES A AND B WITH EXISTING LIGHTNING PROTECTION SYSTEM. WHERE CONFLICTS ARISE, ADJUST LIGHTNING PROTECTION CABLES AROUND NEW POLES.

KEYED NOTES:

- LIGHT POLE SHALL BE MOUNTED ON EXISTING GARAGE C STRUCTURE. STRUCTURAL ENGINEER TO DETERMINE PHYSICAL TIE-IN CONDITIONS AND STRUCTURAL LOADING. LIGHT FIXTURE SHALL BE INSTALLED AT 5' ABOVE ELEVATED ROAD FINISHED GRADE.
- LIGHT POLE SHALL BE MOUNTED ON EXISTING GARAGE B STRUCTURE. STRUCTURAL ENGINEER TO DETERMINE PHYSICAL TIE-IN CONDITIONS AND STRUCTURAL LOADING. LIGHT FIXTURE SHALL BE INSTALLED AT 5' ABOVE ELEVATED ROAD FINISHED GRADE.
- EXISTING LIGHTS MOUNTED TO SHADE AND CONCRETE STRUCTURES ON TERMINAL BUILDING SIDE ARE NOT IN SCOPE. REFER TO TERMINAL RENOVATIONS.
- ROADWAY LIGHTING SHALL COORDINATE WITH FUTURE TERMINAL CANOPY DESIGN IN THIS LOCATION.
- RE-USE EXISTING POLE LOCATION AND ANCHOR BOLTS. SEE DETAIL 2/ES903-900R.

NOTE TO REVIEWER:
PHASING PLANS WILL REQUIRE ADDITIONAL COORDINATION BETWEEN GARAGE AND TERMINAL WORK PRIOR TO 100% SUBMITTAL.

FEEDER SCHEDULE				
TAG	FEEDER SIZE	CONDUIT	MOUNTING	SPARES
A	(2) #10's, #10 GRD	1" C	SURFACE	-
B	(3) #10's, #10 GRD	1" C	SURFACE	-
C	(4) #10's, #10 GRD	1" C	SURFACE	-
D	(5) #10's, #10 GRD	1" C	SURFACE	-
E	(6) #10's, #10 GRD	1" C	SURFACE	-
F	(9) #10's, #10 GRD	1" C	SURFACE	-
G	(2) #6's, #8 GRD	1" C	SURFACE / BELOW GRADE	-
H	(2) #6's, (2) #10's, #8 GRD	1" C	SURFACE / BELOW GRADE	1" C
I	(4) #6's, #8 GRD	1-1/2" C	SURFACE / BELOW GRADE	1-1/2" C

*based on XHHW and RGS

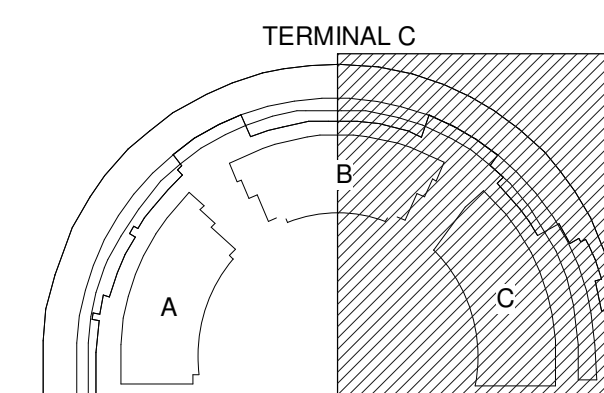

Permits:
A21-188B - Terminal C Garage C
B22-0021 - Terminal C Garage B
B22-0023 - Terminal C Roadway

1 UPPER LEVEL - Lighting South
1" = 40'-0"



2330 N INTERNATIONAL PARKWAY
DFW AIRPORT, TX 75261

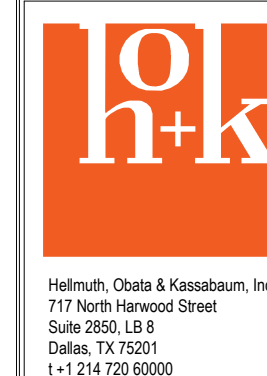
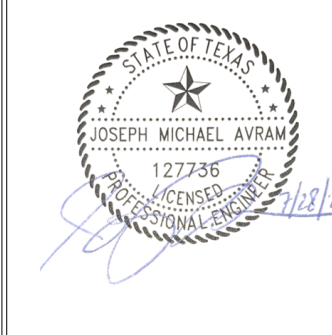

Primera

Primera Engineers, LLC
3000 East Loop
Suite 214
Dallas, TX 75201
1-214-722-6000

PROJECT NUMBER: TFD007

DRAWN BY: BMAY
APPROVED BY: RL/D5
ISSUE DATE: 2022-07-28

NOT FOR BID OR CONSTRUCTION

NO.	DATE	DESCRIPTION
2021-10-29	30% DESIGN	
2022-01-09	70% DESIGN	
2022-05-01	100% DESIGN	
2022-07-28	100% ISSUED FOR PERMIT (IFP)	

PROJECT NUMBER: TFD-007

TERMINAL C GARAGE AND ROADWAYS
LIGHTING NEW WORK - UPPER ROADWAY, SOUTH

PERMIT NUMBER: A21-188B

SHEET NUMBER
ES108-900R

SCALE(S) AS NOTED ON THIS SHEET ARE BASED ON A FULL SIZE 30 X 42 SHEET.

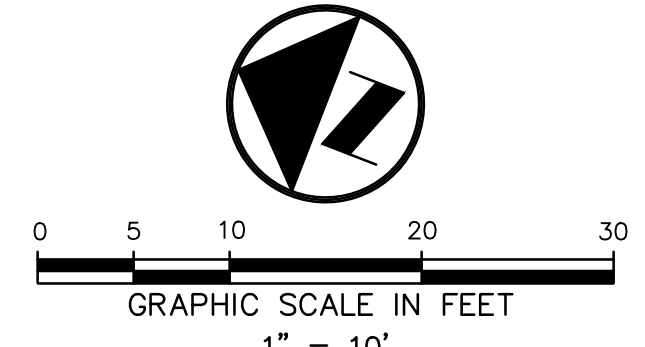
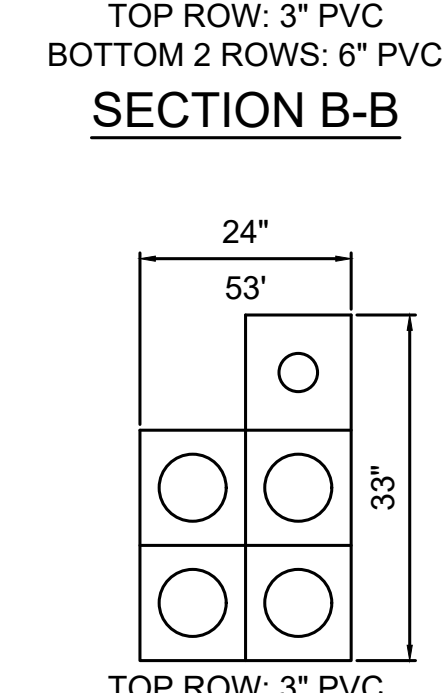
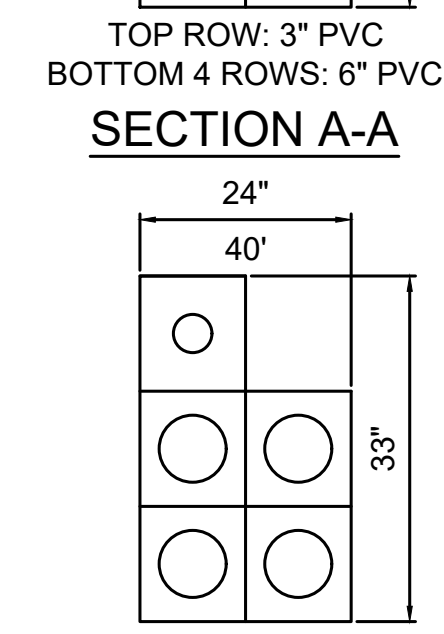
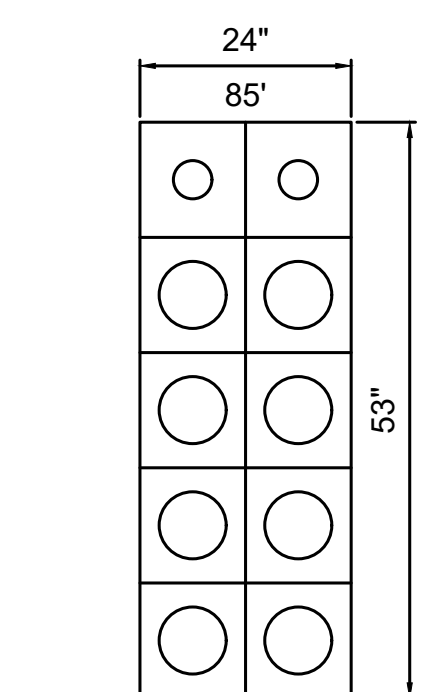
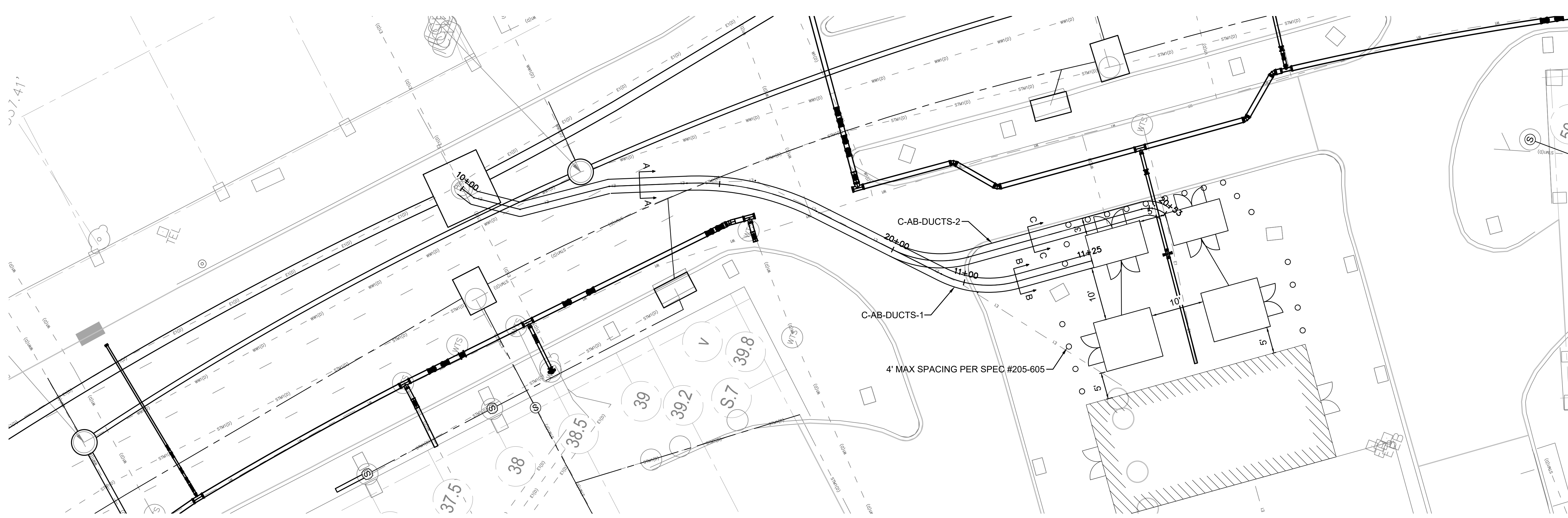

GENERAL NOTES

1. SEE SHEET ES504-900R FOR ONCOR DUCT BANK DETAILS AND REQUIREMENTS.
2. SEE CIVIL ROADWAY PLANS FOR CURB AND PAVEMENT IMPROVEMENTS.
3. VERIFY SIZE AND DEPTHS OF UTILITIES TO BE CROSSED PRIOR TO CONSTRUCTION.
4. MAINTAIN MINIMUM 18" VERTICAL SEPARATION AT ALL UTILITY CROSSINGS.
5. SEE SHEET E-002-900R FOR GENERAL ELECTRICAL NOTES.
6. TEMPORARY PACK PAVEMENT TO GET ROADWAYS BACK IN SERVICE AFTER DUCTBANK IS INSTALLED.

LEGEND

- ==== DUCT BANK (SEE SHEET ES504-900R FOR DETAILS)
- BOLLARD (SEE SHEET ES504-900R FOR DETAILS)

C-AB-DUCTS-1 PROFILE

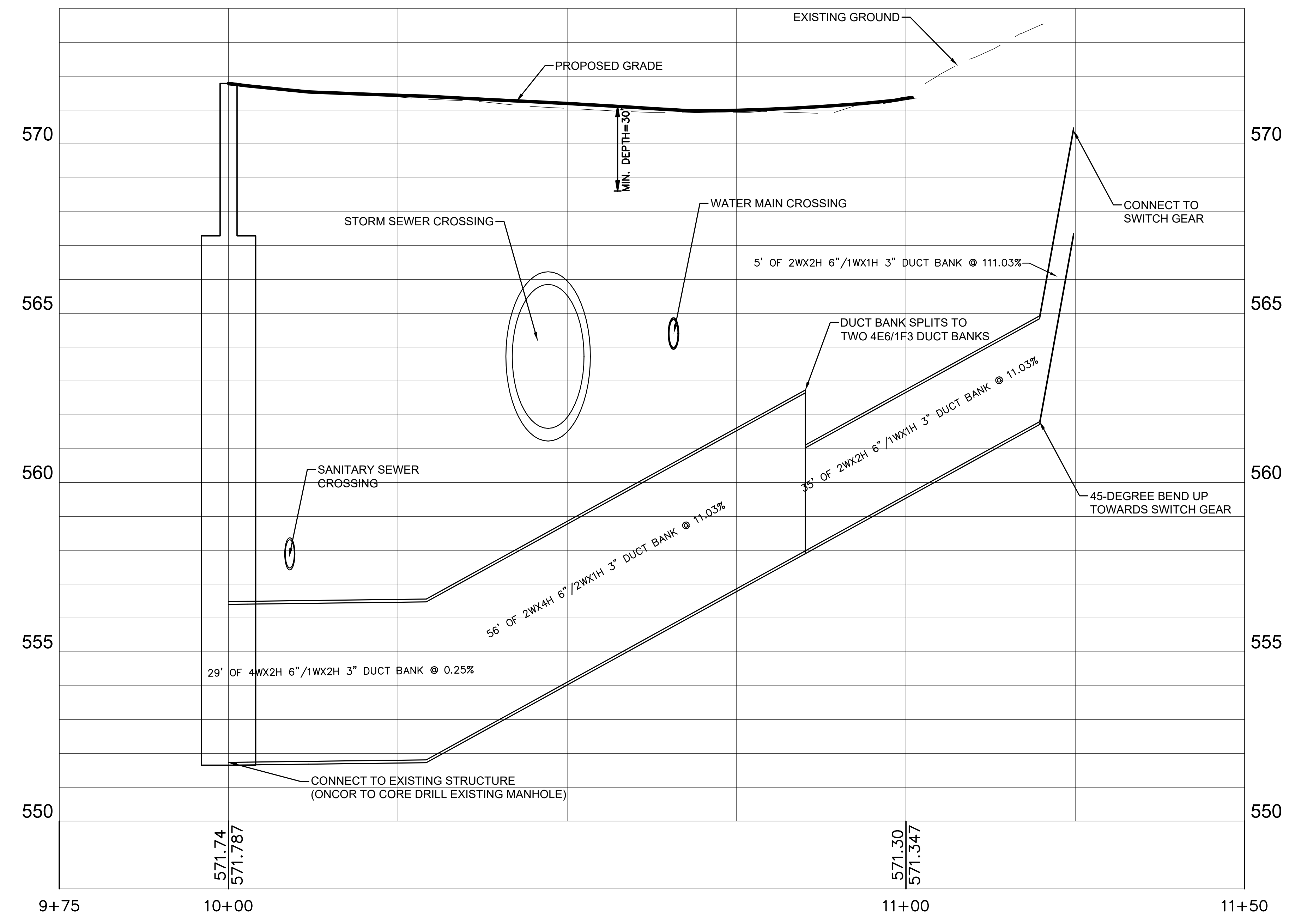

C-AB-DUCTS-2 PROFILE

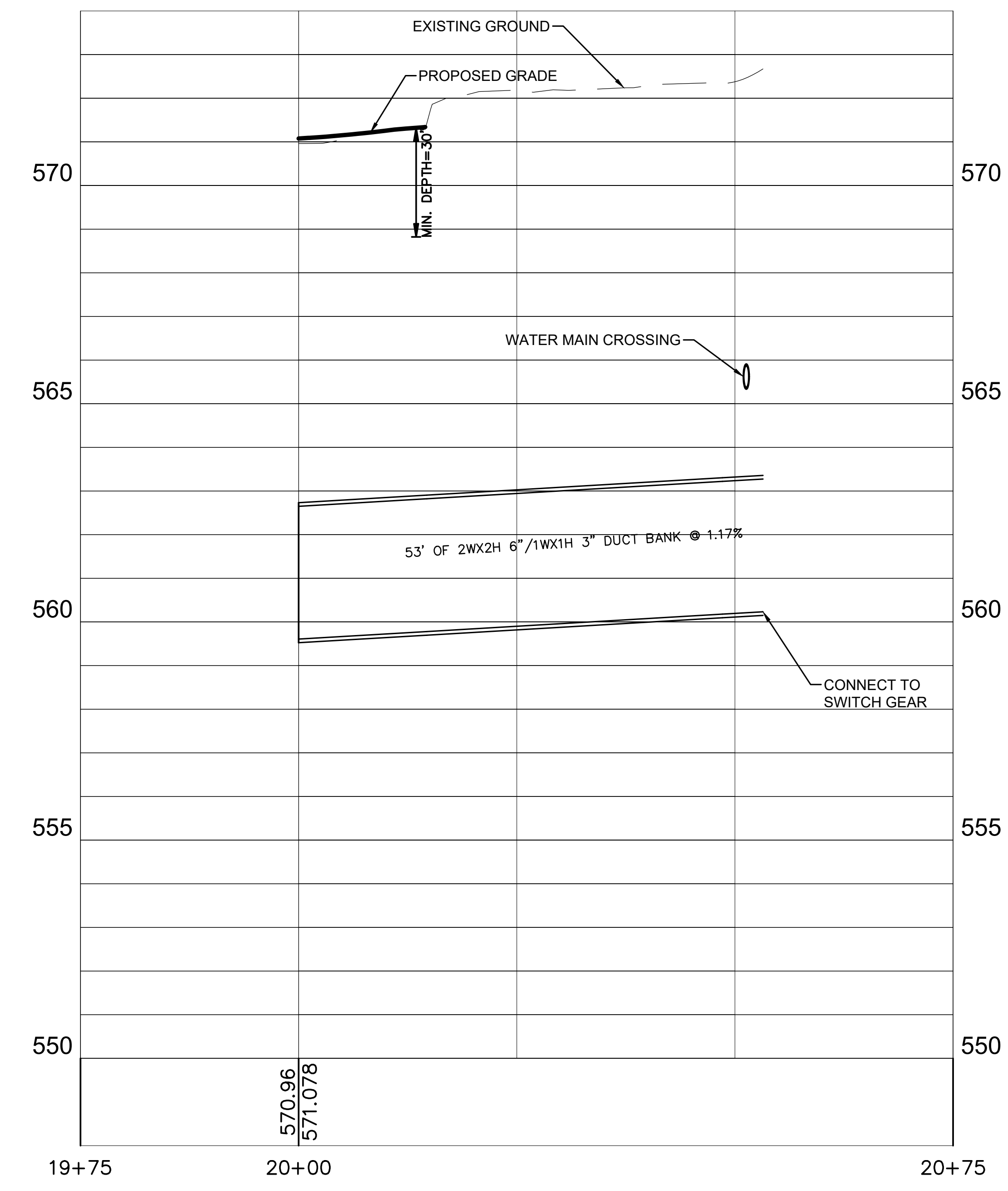

KEY PLAN

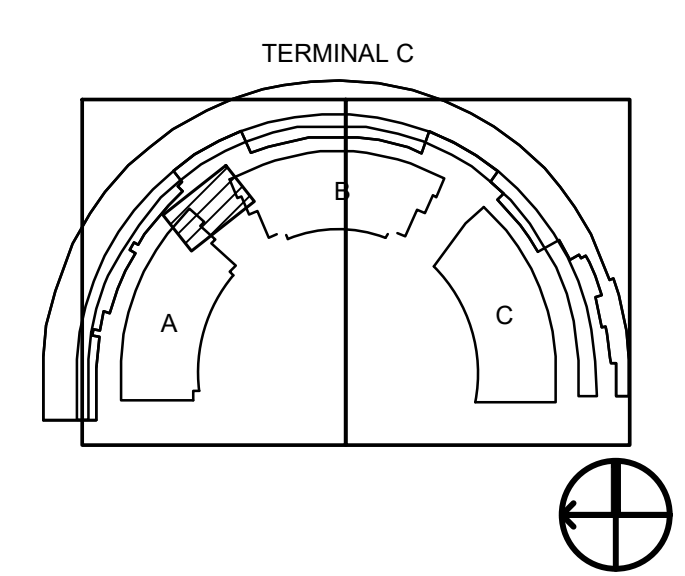

BORDER RELEASE DATE: October 16, 2021
 01/20/2021 7:46:09 AM
 C:\Users\michaelr\OneDrive\Documents\DFW\Terminal C Garage and Roadways\ES201-900R\Terminal C Garage and Roadways\ES201-900R_ElectricalProfile.dwg

2330 N INTERNATIONAL PARKWAY
 DFW AIRPORT, TX 75261

Primera Engineers, Ltd.
 300 West Fair
 Suite 211
 Dallas, TX 75201
 (+1) 214 720 8000 (+1) 312 606 0910

DRAWN BY: CTM
 APPROVED BY: EM
 ISSUE DATE: 2022-07-28
NOT FOR BID OR CONSTRUCTION

NO.	DATE	DESCRIPTION
2022-07-28	30% DESIGN	
2022-01-09	30% DESIGN	
2022-01-09	100% DESIGN	
2022-01-09	100% DESIGN FOR PERMIT (DPP)	

PROJECT NUMBER: TFD-007

TERMINAL C GARAGE & ROADWAYS
ELECTRICAL DUCT BANK PLAN AND PROFILE, NORTH

PERMIT NUMBER: A21-1888, B22-0023

SHEET NUMBER
ES201-900R

SCALE(S) AS NOTED ON THIS SHEET ARE BASED ON A FULL SIZE 30 X 42 SHEET.

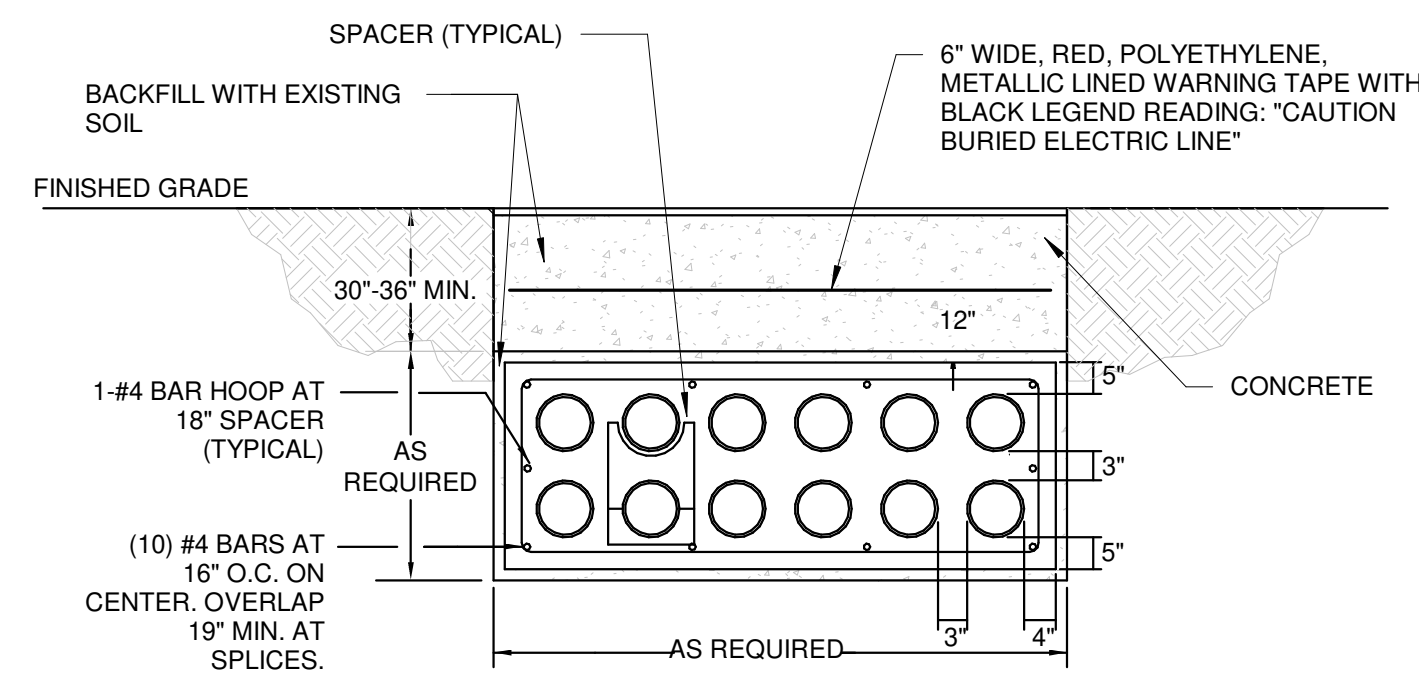

- GENERAL NOTES:**
1. SIZE AND QUANTITY OF CONDUITS AS NOTED ON PLANS AND/OR RISER DIAGRAM
 2. DUCTBANK TO BE ROUTED BELOW 4' FOOTINGS AT NEW SWITCHGEAR BUILDING.
 3. INSTALL DUCTBANK IN ACCORDANCE WITH DFW DESIGN CRITERIA MANUAL, CURRENT EDITION.
 4. ALL CONDUITS TO BE PVC. CHANGE TO GRS 10FT PRIOR TO THE ENTRANCE TO THE BUILDING.
 5. 36" MIN RADIUS.

1 2 x N CONCRETE ENCASED DUCTBANK DETAIL NTS

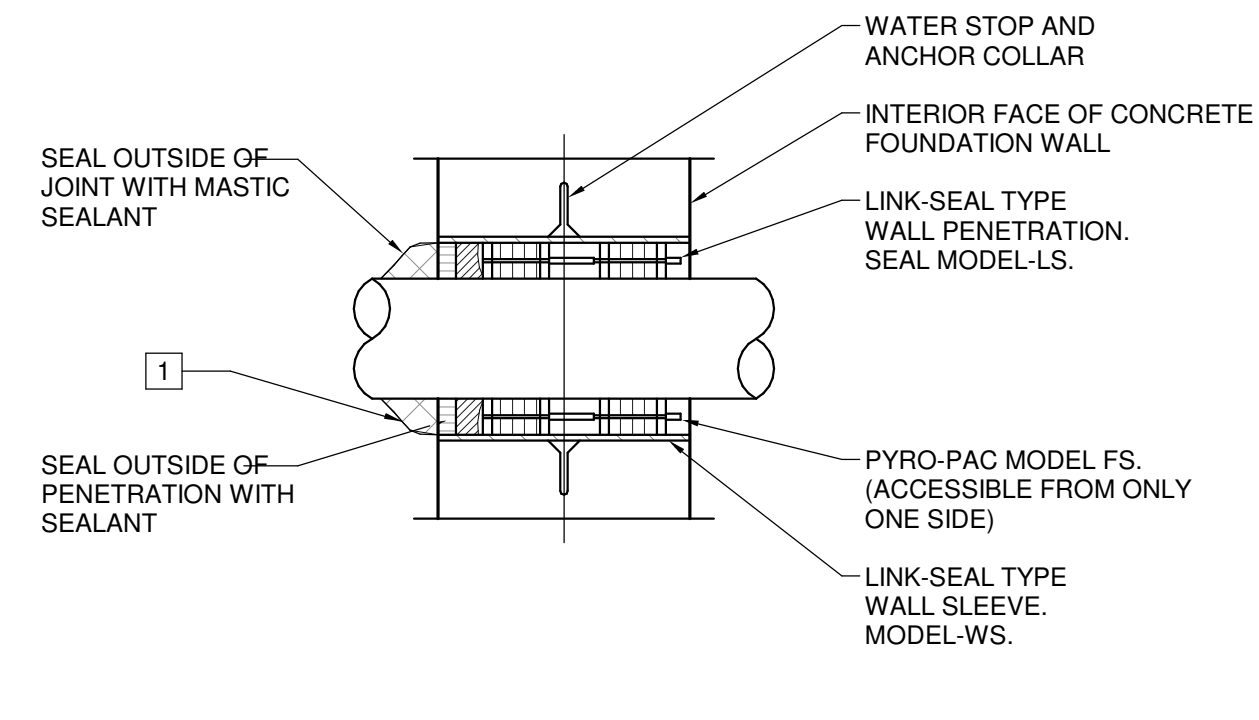

- KEYED NOTES:**
1. WHEN PENETRATION IS EXPOSED, PROVIDE CHROME (OR STAINLESS STEEL) ESCUTCHEON COVER PLATE ON EXPOSED SIDE. COORDINATE WITH ARCHITECT FINISH REQUIREMENTS.

5 CONDUIT EXTERIOR WALL PENETRATION NTS

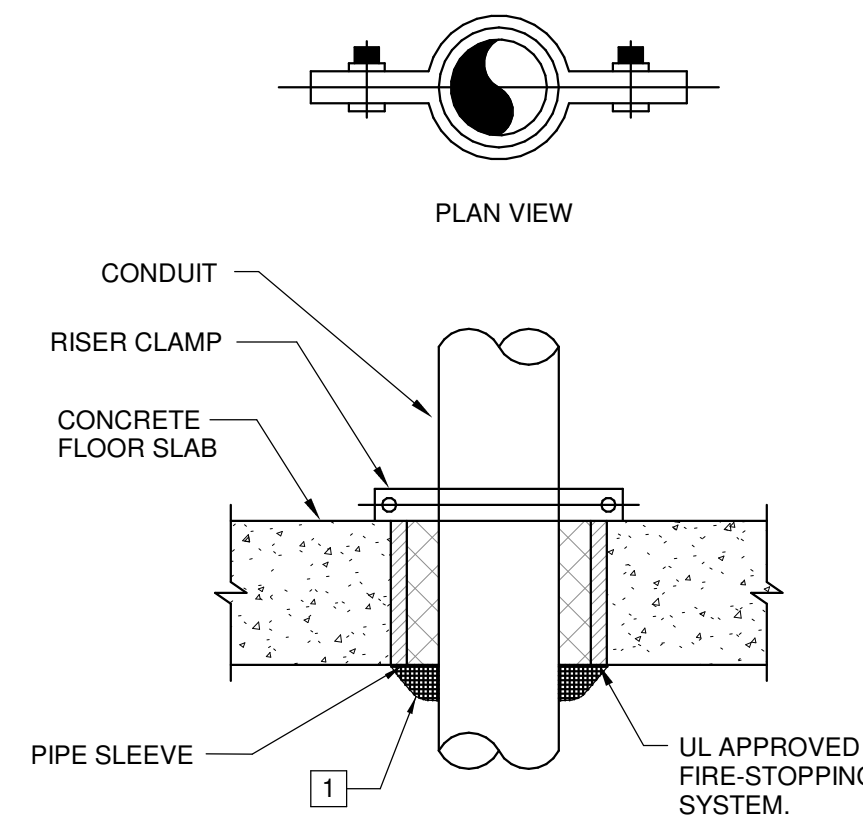

- KEYED NOTES:**
1. WHEN PENETRATION IS EXPOSED, PROVIDE CHROME (OR STAINLESS STEEL) ESCUTCHEON COVER PLATE ON EXPOSED SIDE. COORDINATE WITH ARCHITECT FINISH REQUIREMENTS.

6 CONDUIT INTERIOR FLOOR PENETRATION NTS

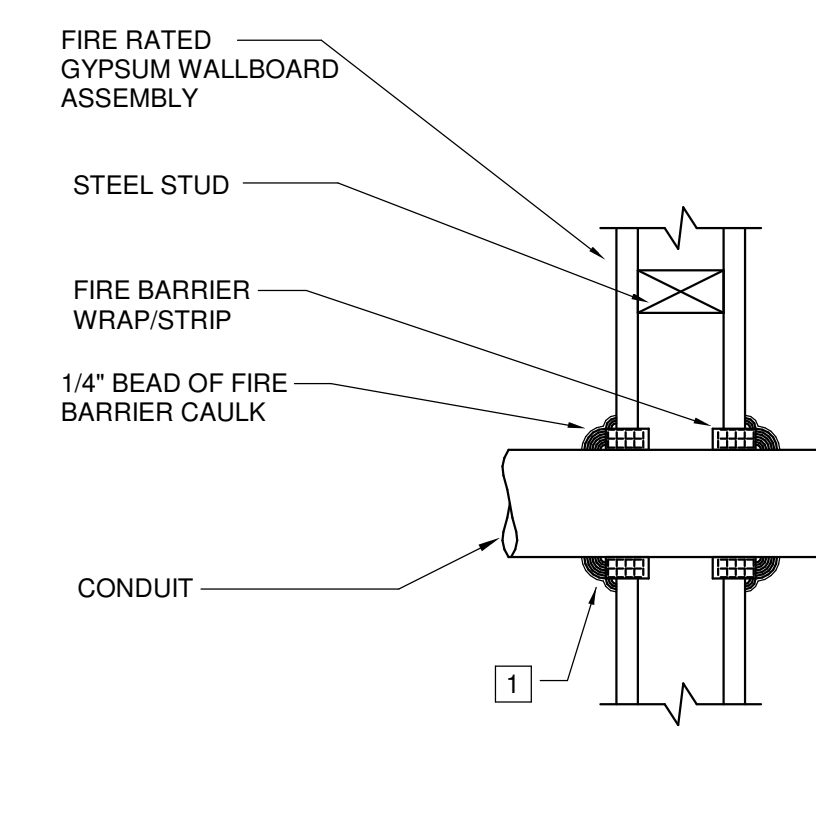

- KEYED NOTES:**
1. WHEN PENETRATION IS EXPOSED, PROVIDE CHROME (OR STAINLESS STEEL) ESCUTCHEON COVER PLATE ON EXPOSED SIDE. COORDINATE WITH ARCHITECT FINISH REQUIREMENTS.

7 CONDUIT INTERIOR GYP. BOARD WALL PENETRATION DETAIL NTS

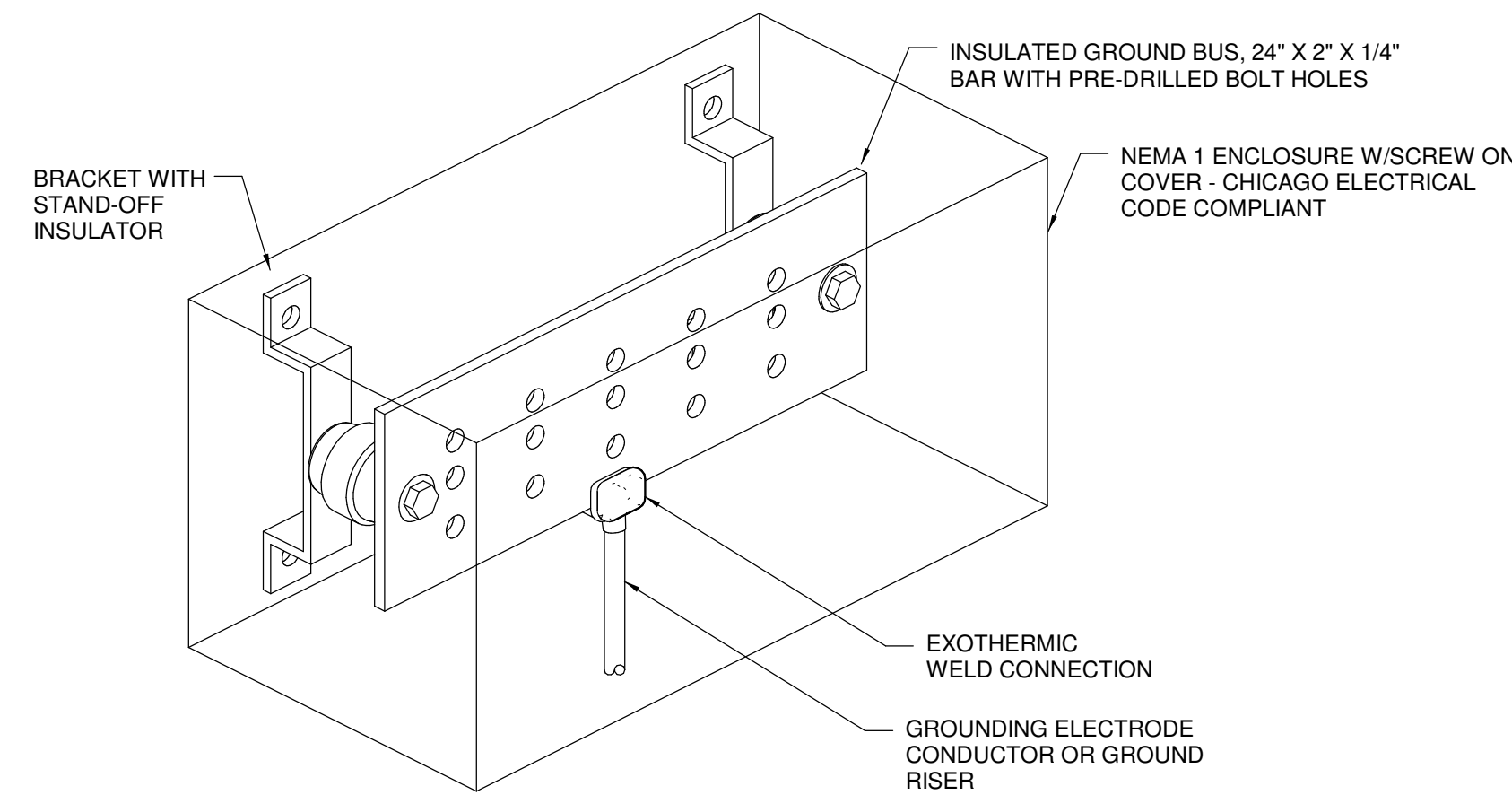

4 GROUND BUS DETAIL NTS

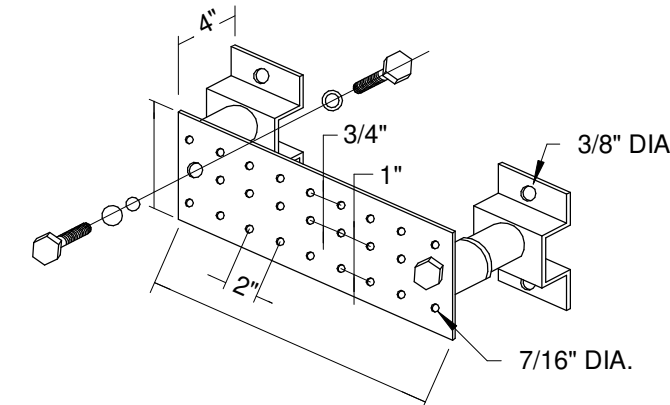

GENERAL NOTES:

1. SOLID COPPER GROUND BUS-BARS 1/4" THICK FOR WALL AND BACKBOARD MOUNTING.
2. PROVIDES 4" STANDOFF FROM BACKBOARD. KIT CONSISTS OF: 1- EACH BUS-BAR 2- EACH INSULATORS 2- EACH STANDOFF BRACKETS AND ASSEMBLY SCREWS.

2 GROUND BUS BAR KIT - WALL MOUNTED NTS

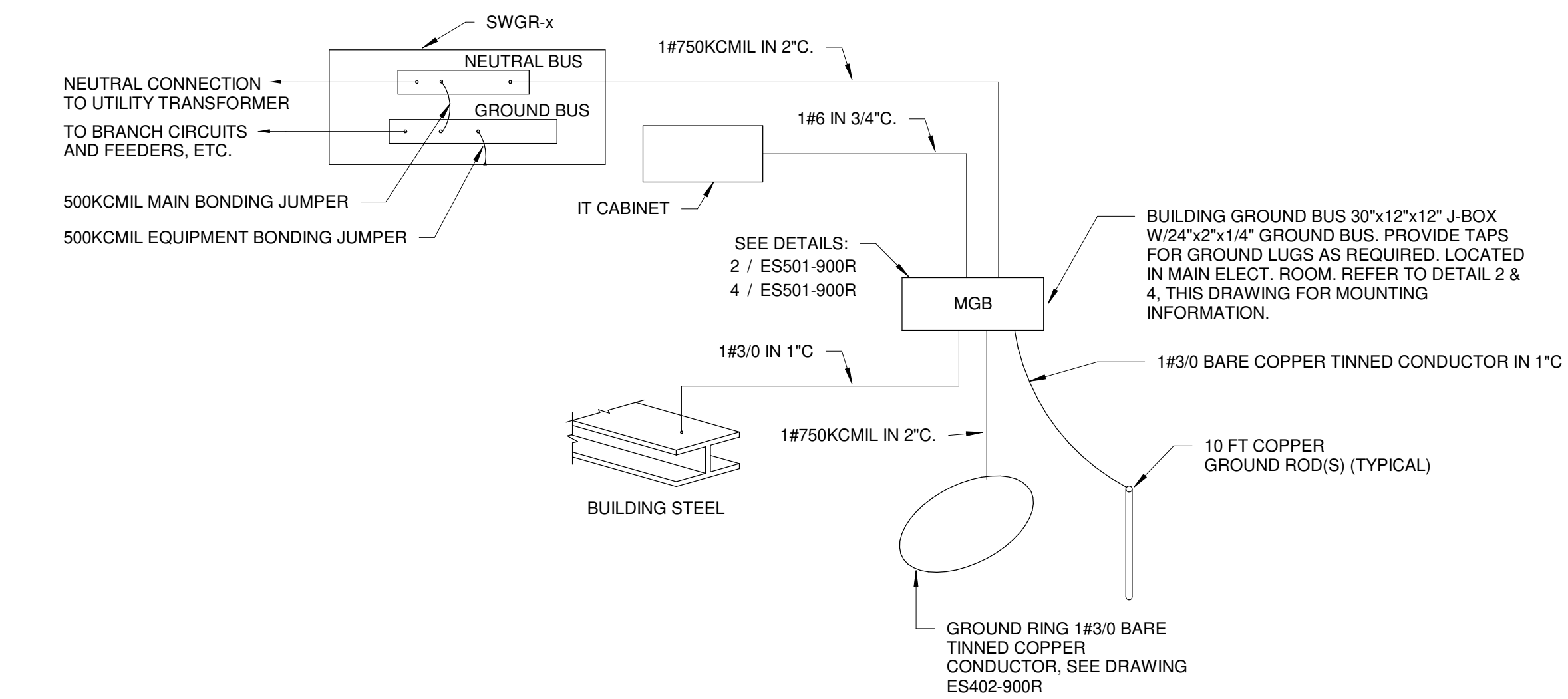

NOTES:

1. PROVIDE GROUND BUS MOUNTED IN NEMA 1, STEEL ENCLOSURE WITH SCREW-ON COVER. GROUND BUS SHALL BE BOLTED TO WALL VIA STAND-OFF INSULATORS.
2. RISER IS TYPICAL FOR EACH SWITCHGEAR ENCLOSURE

3 MAIN SERVICE GROUNDING DETAIL NTS

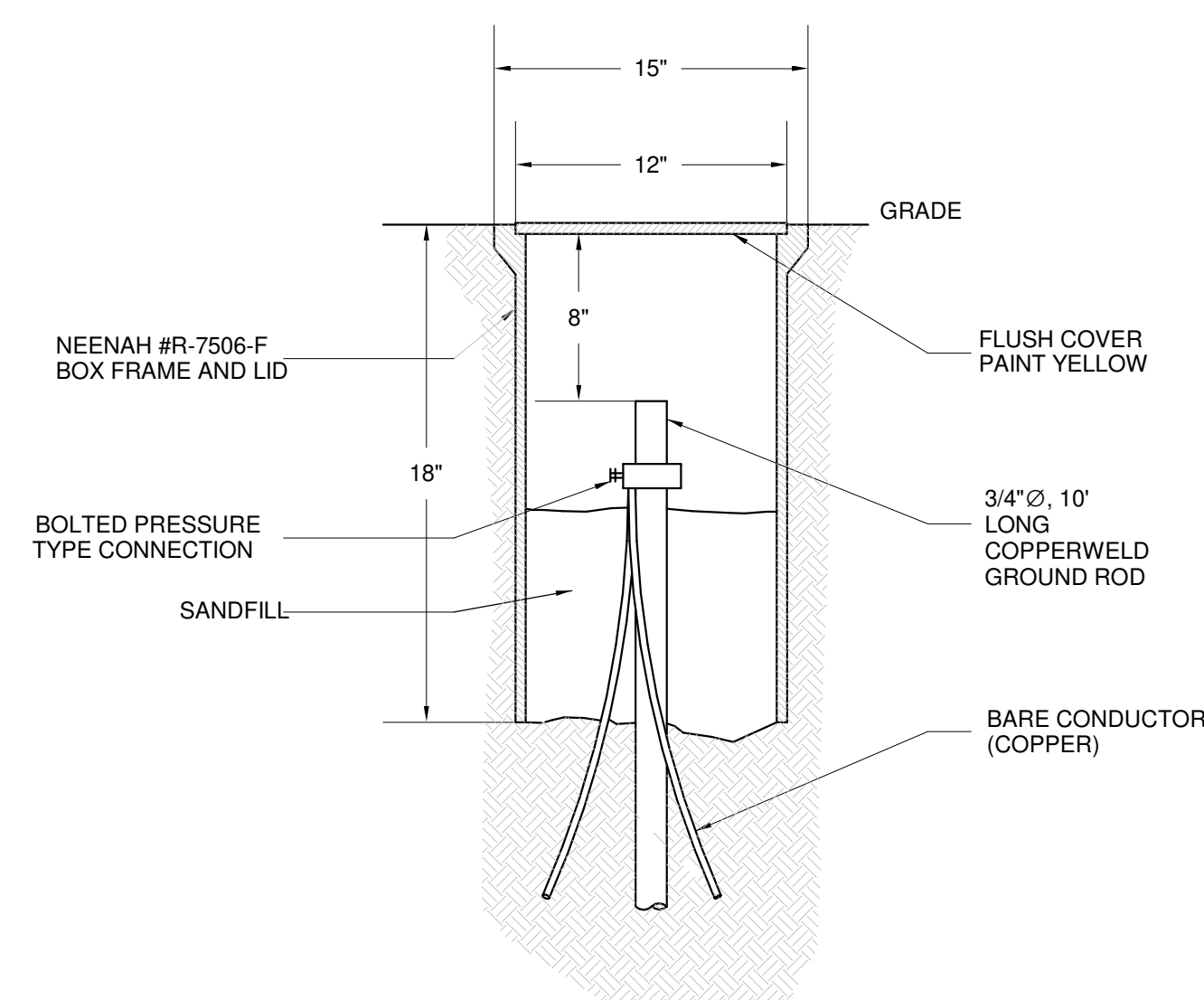

8 GROUND TEST WELL DETAIL NTS

Permits:
A21-1888 - Terminal C Garage C
B22-0023 - Terminal C Roadway

NO.	DATE	DESCRIPTION
2021-10-29	30% DESIGN	
2022-01-06	70% DESIGN	
2022-08-01	100% DESIGN	
2022-07-28	100% ISSUED FOR PERMIT (IFP)	

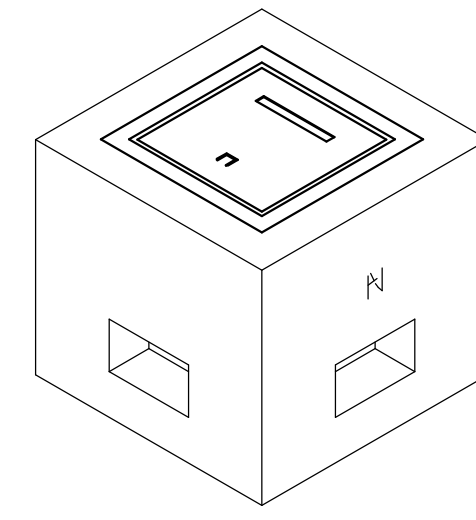
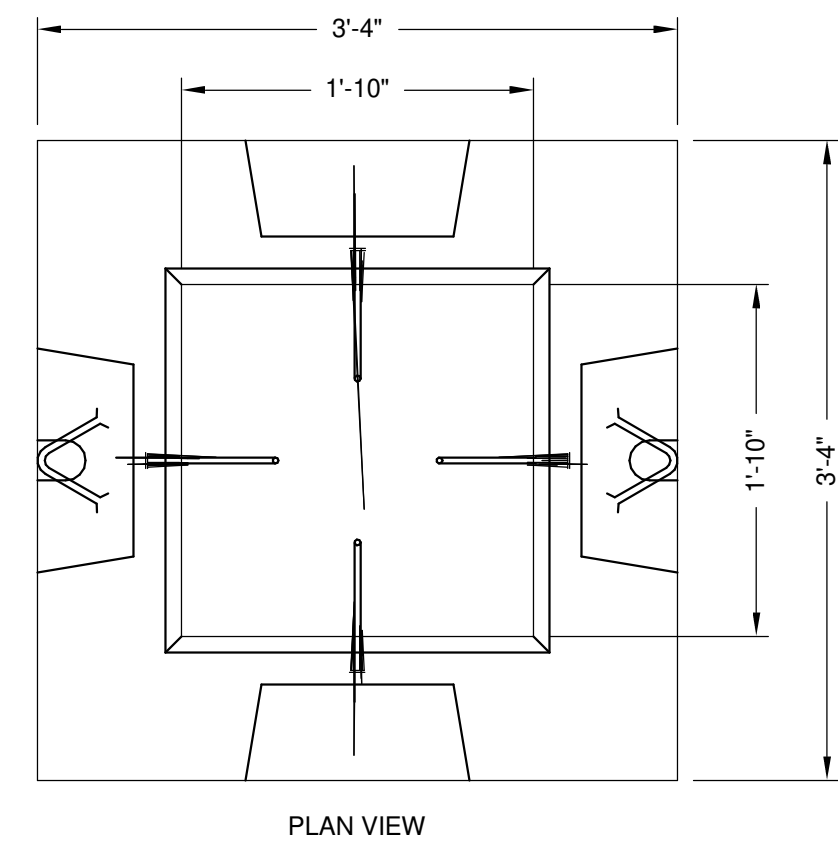

- MATERIALS:**
1. CONCRETE: 6,500 p.s.i. @ 28 DAYS 5%-8% ENTRAINED AIR.
 2. REBAR: ASTM A-615, GRADE 60, BLACK BAR.
 3. (2) 4 1/2" MIN. SLAB, UTILITY ANCHORS (LAUBP-UA450334G).
 4. (4) 2/3" 8" PLASTIC THREADED INSERTS.
 5. (4) 2/3" 8" GALVANIZED CABLE HOOKS.
 6. (1) CAST-IN FRAME & COVER (NEENAH R-6660-JP, LETTERED "ELECTRIC").
 7. STRUCTURE TOLERANCE= ±1/4".
 8. WEIGHT: 3,150# (NOT INCLUDES CAST-IN F&C).

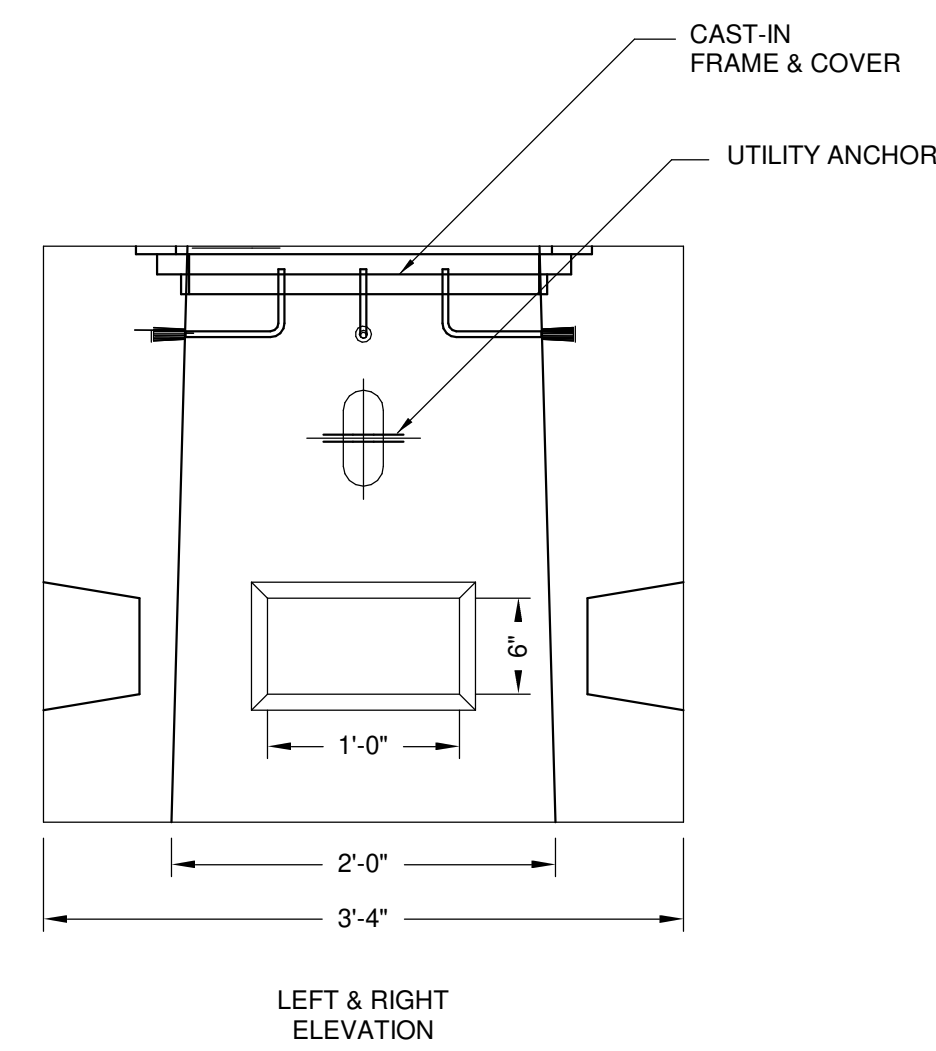
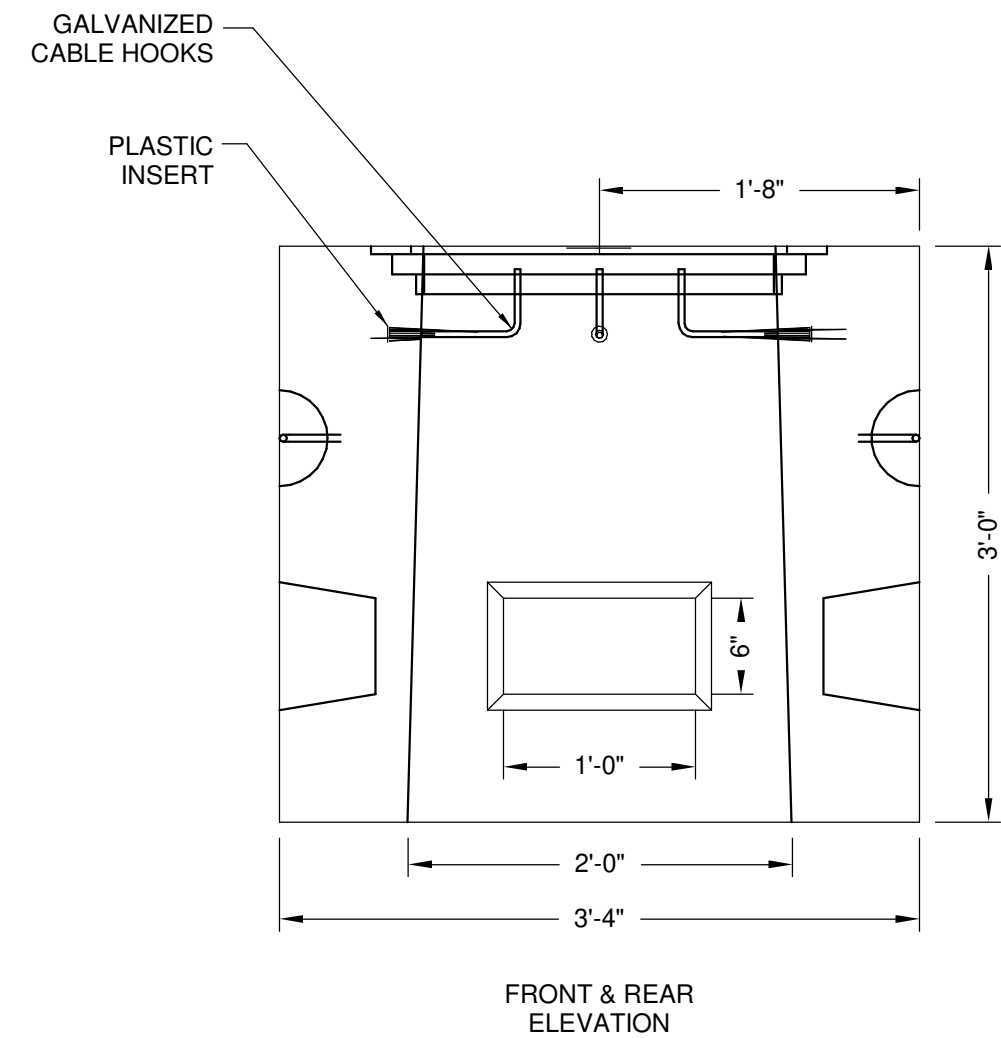

PRECAST CONCRETE HANDHOLE DETAIL

- NOTES:**
1. E.C. SHALL ORIENT HANDHOLE SHALL BE INSTALLED PERPENDICULAR TO PATH OF TRAVEL.
 2. SEE CIVIL DETAILS FOR BONDING AROUND HANDHOLE.
 3. DIMENSIONS FOR HANDHOLES H# SHALL BE 36"x36"x48" DEPTH IN LIEU OF THOSE SHOWN. INCREASE SIDE OPENINGS AS NEEDED TO ACCOMMODATE DUCTBANKS.
 4. ALL OTHER HANDHOLES SHALL BE DIMENSIONED AS SHOWN.
 5. PROVIDE GROUNDING PER SPECIFICATIONS.
 6. PROVIDE FRAME AND COVER WITH BLACK ASPHALTIC DIP FINISH.

① HANDHOLE DETAIL
NTS

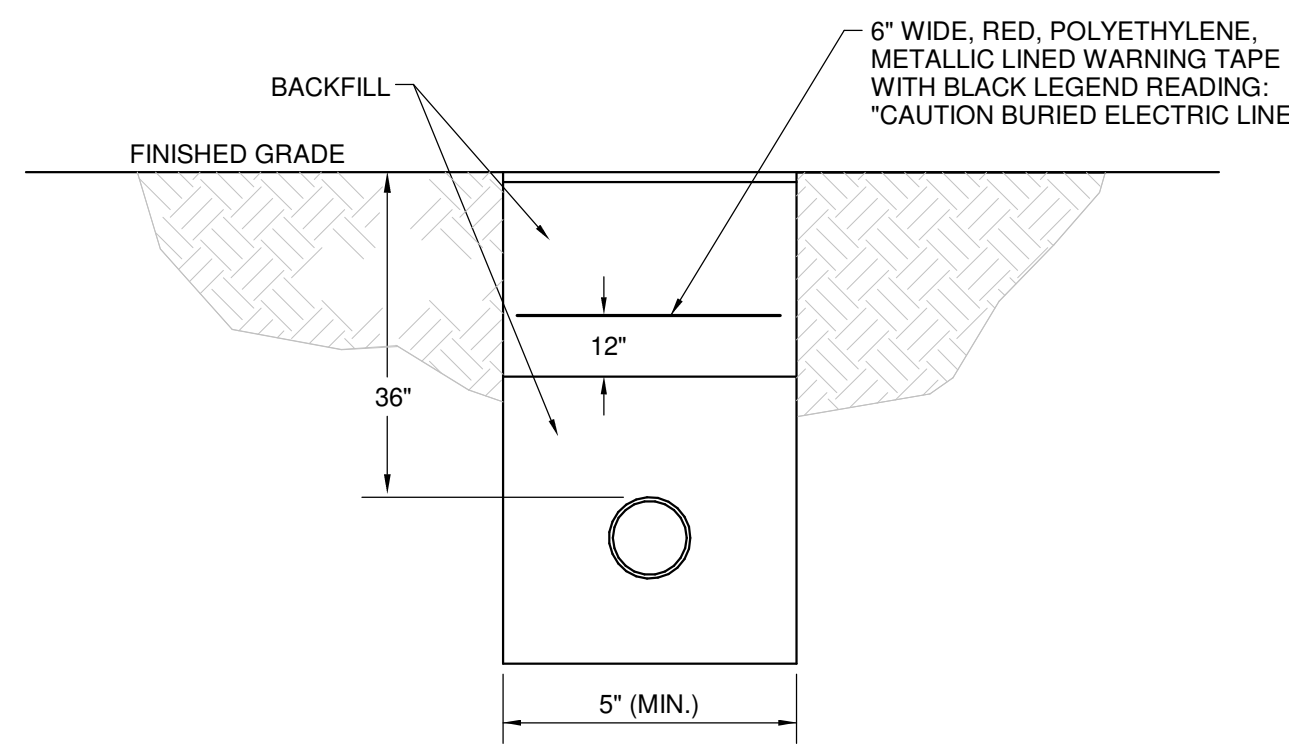

- NOTES:**
1. SIZE AND QUANTITY OF CONDUITS AS NOTED ON PLANS AND/OR RISER DIAGRAM.

② DIRECT BURIED CONDUIT DETAIL
NTS

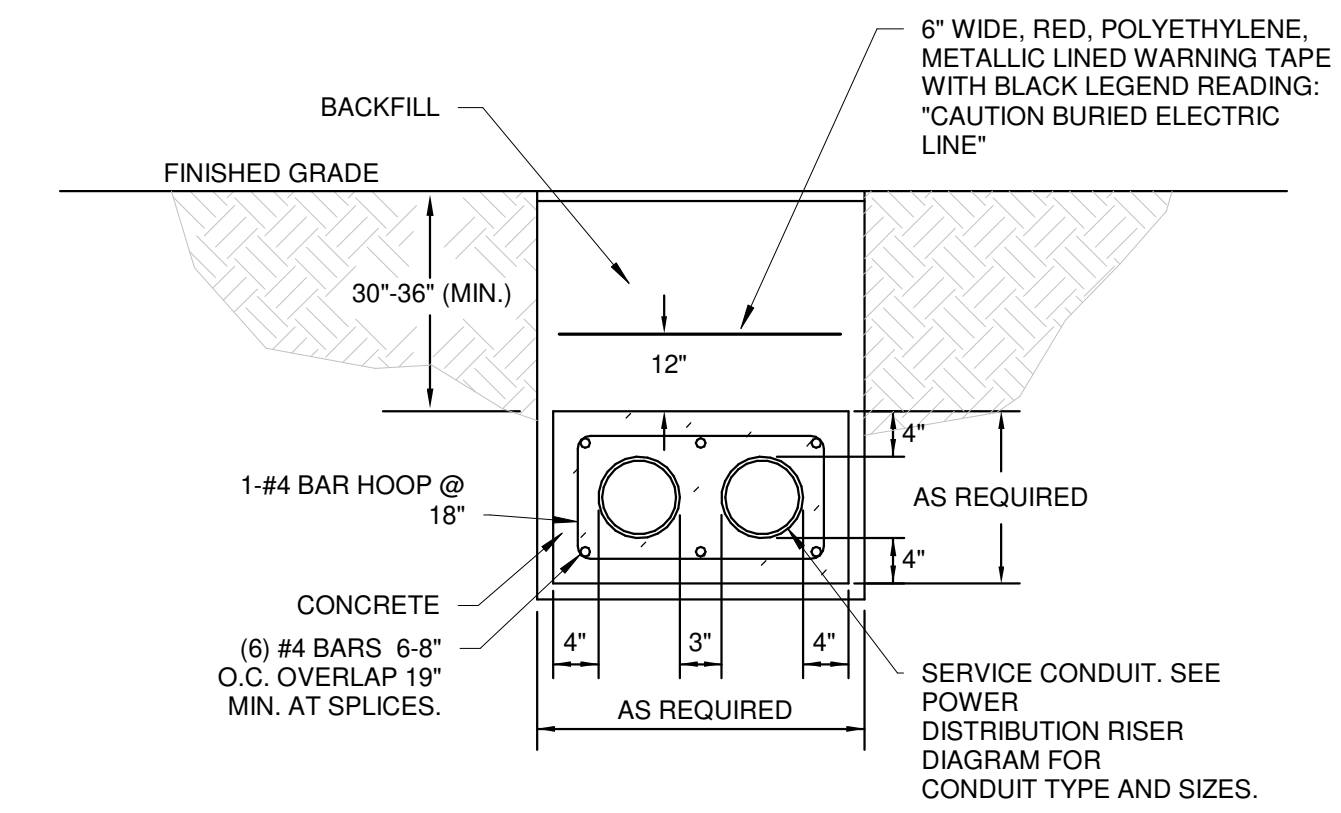

- NOTES:**
1. SIZE AND QUANTITY OF CONDUITS AS NOTED ON PLANS AND/OR RISER DIAGRAM.
 2. INSTALL DUCTBANK IN ACCORDANCE WITH DFW DESIGN CRITERIA MANUAL, CURRENT EDITION.
 3. ALL CONDUITS TO BE PVC. CHANGE TO GRS 10FT PRIOR TO THE ENTRANCE TO THE BUILDING.
 4. 38\"/>

③ 1 x N CONCRETE ENCASED DUCTBANK DETAIL
NTS

Permits:
A21-1888 – Terminal C Garage C
B22-0023 – Terminal C Roadway



2330 N INTERNATIONAL PARKWAY
DFW AIRPORT, TX 75261

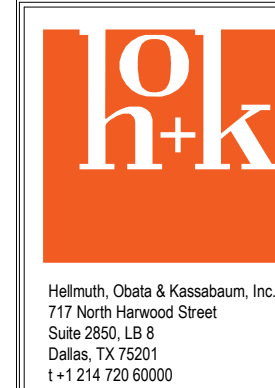

Primera

Joseph Michael Avram
127736
Dallas, TX 75201
1-214-722-6000

Primera Engineers, Ltd.
3000 East
Suite 214
Coppell, TX 75011
1-972-899-9910

PROJECT NUMBER: TFD007

DRAWN BY: BM/AY
APPROVED BY: RL/OS
ISSUE DATE: 2022-07-28

**NOT FOR BID OR
CONSTRUCTION**

NO.	DATE	DESCRIPTION
2021-10-29	30% DESIGN	
2022-01-06	70% DESIGN	
2022-08-01	100% DESIGN	
2022-07-28	100% ISSUED FOR PERMIT (IFP)	

PROJECT NUMBER: TFD-007

TERMINAL C GARAGE AND ROADWAYS
ELECTRICAL DETAILS

PERMIT NUMBER: A21-1888

SHEET NUMBER

ES502-900R

SCALE(S) AS NOTED ON THIS SHEET ARE BASED ON A FULL SIZE 30 X 42 SHEET.

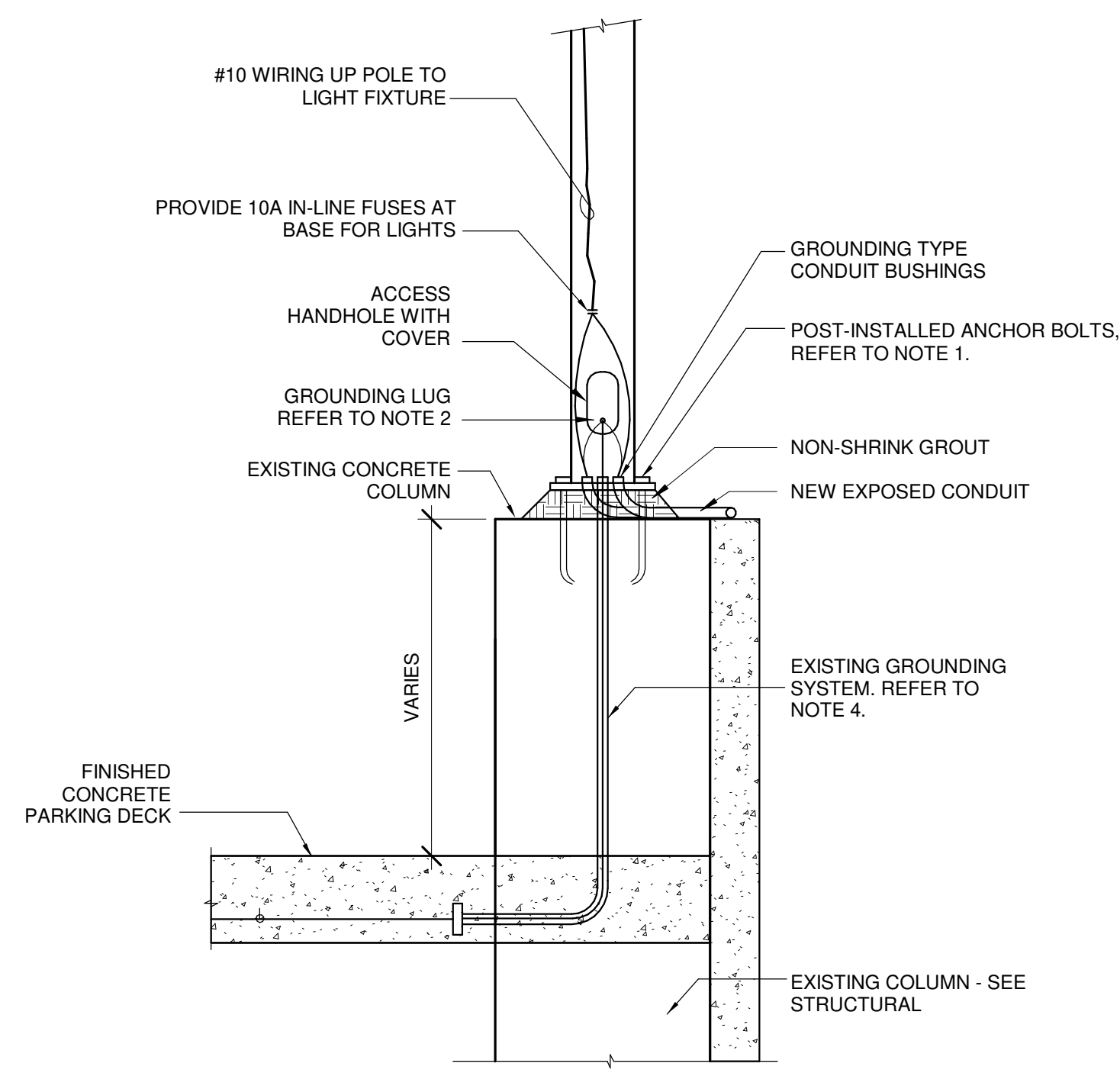

NOTES:

1. PROVIDE POST-INSTALLED ANCHOR BOLTS PER STRUCTURAL ENGINEER DETAILS / DIRECTION. BOLT POLE BASE PER MANUFACTURER'S INSTRUCTIONS AND BOLT TEMPLATES, WITH MINIMUM LENGTH OF 36"x3/4". GROUT AS REQUIRED WITH NON-SHRINK GROUT.
2. TERMINATE ALL CONDUITS WITH GROUNDING BUSHINGS BONDED TO GROUND LUG.
3. PROVIDE IN-LINE FUSE AT POLE BASE.
4. TIE INTO EXISTING GROUNDING SYSTEM. IF NO GROUNDING SYSTEM EXISTS, TIE INTO REBAR SYSTEM FOR GROUNDING.
5. PROVIDE BOLT COVER (NOT SHOWN).

① POLE BASE DETAIL - FIXTURE F1,F1A,F1B @ GARAGE A,B ROOF-NEW BOLT CONDITION NTS

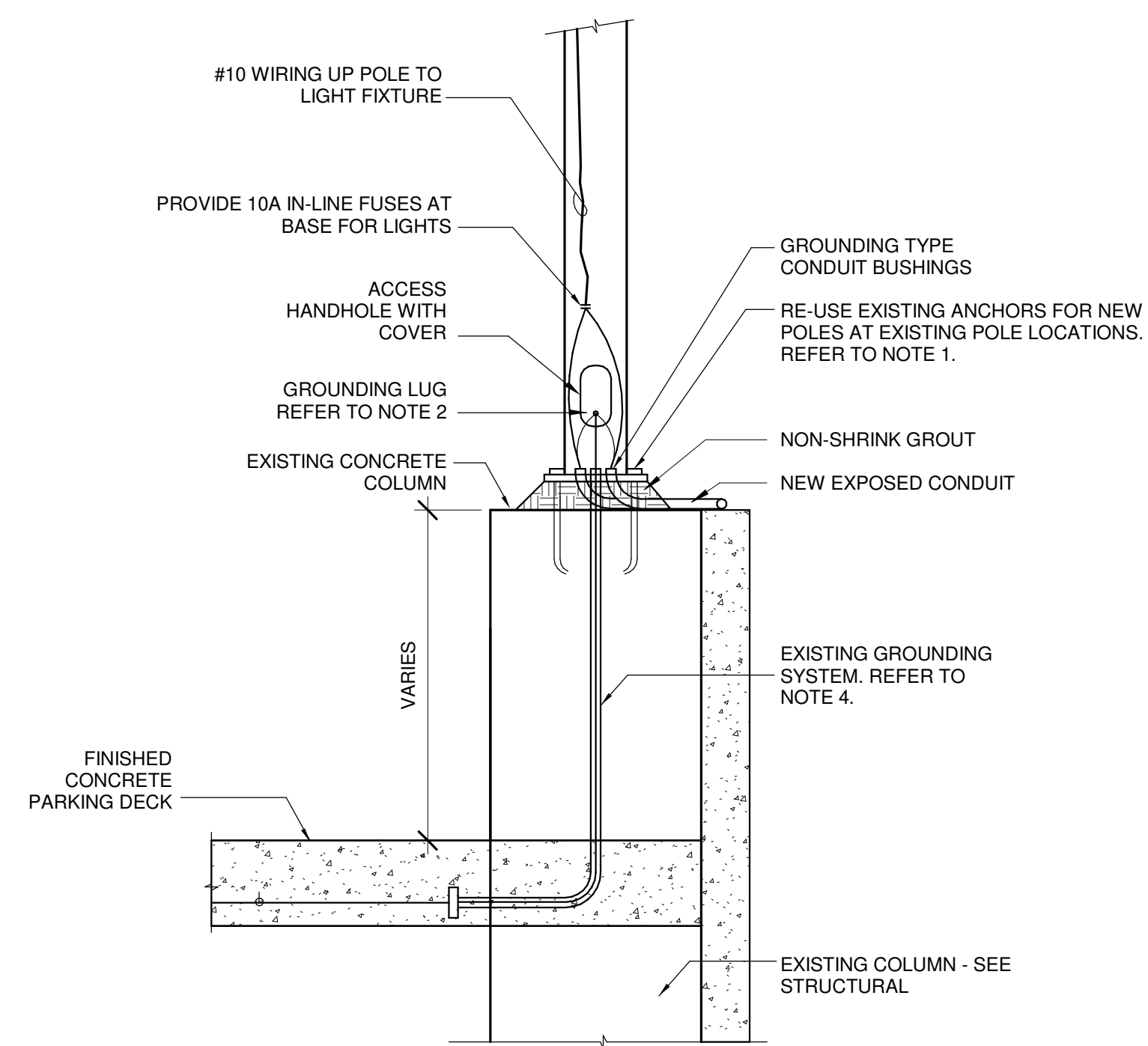

NOTES:

1. CONTRACTOR TO COORDINATE EXISTING ANCHOR BOLT PATTERN WITH POLE MANUFACTURER AS PART OF SHOP DRAWING PROCESS. POLES MUST MODIFY TO WORK WITH EXISTING ANCHOR BOLT SPACING PER STRUCTURAL CONCERNS. PROVIDE CUSTOM POLE AS NEEDED.
2. TERMINATE ALL CONDUITS WITH GROUNDING BUSHINGS BONDED TO GROUND LUG.
3. PROVIDE IN-LINE FUSE AT POLE BASE.
4. TIE INTO EXISTING GROUNDING SYSTEM.
5. PROVIDE BOLT COVER (NOT SHOWN).

② POLE BASE DETAIL - FIXTURE F1,F1A,F1B @ GARAGE A,B ROOF-EXISTING BOLT CONDITION NTS

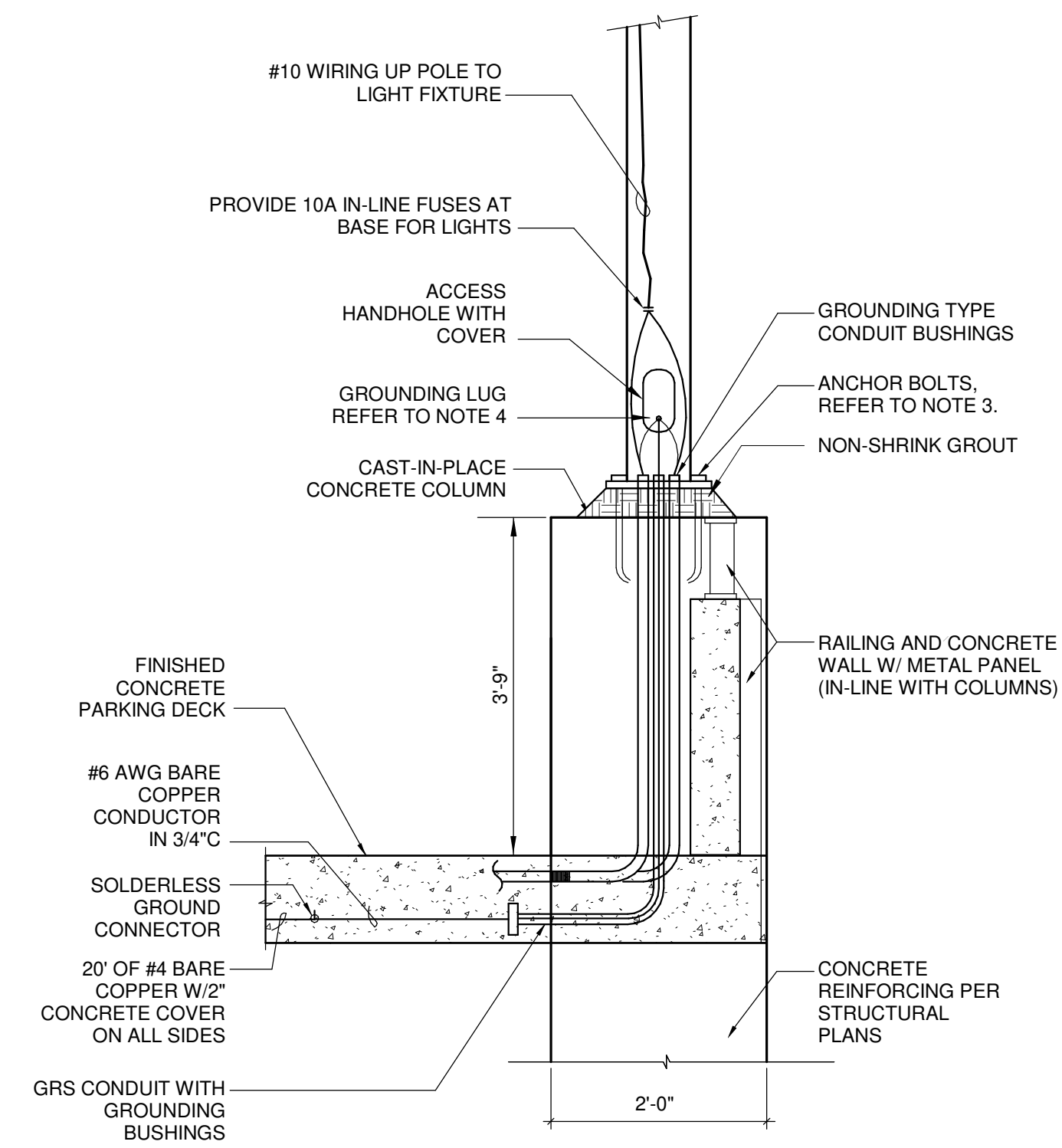

NOTES:

1. TIE TOGETHER ALL GROUNDING CONDUCTORS INCLUDING CONDUCTORS INSTALLED WITH THE CIRCUIT WIRING.
2. WELD ALL STEEL ANCHOR BOLT AND CONDUIT TOGETHER VIA #6 GROUNDING CONDUCTOR. USE EXOTHERMIC WELDINGS.
3. BOLT POLE BASE PER MANUFACTURER INSTRUCTIONS WITH ANCHOR BOLTS MINIMUM LENGTH OF 36"x3/4". GROUT AS REQUIRED WITH NON-SHRINK GROUT.
4. TERMINATE ALL CONDUITS WITH GROUNDING BUSHINGS BONDED TO GROUND LUG.
5. PROVIDE IN-LINE FUSE AT POLE BASE.
6. PROVIDE BOLT COVER (NOT SHOWN).

③ POLE BASE DETAIL - FIXTURE F3,F3A,F3B @ GARAGE C ROOF NTS

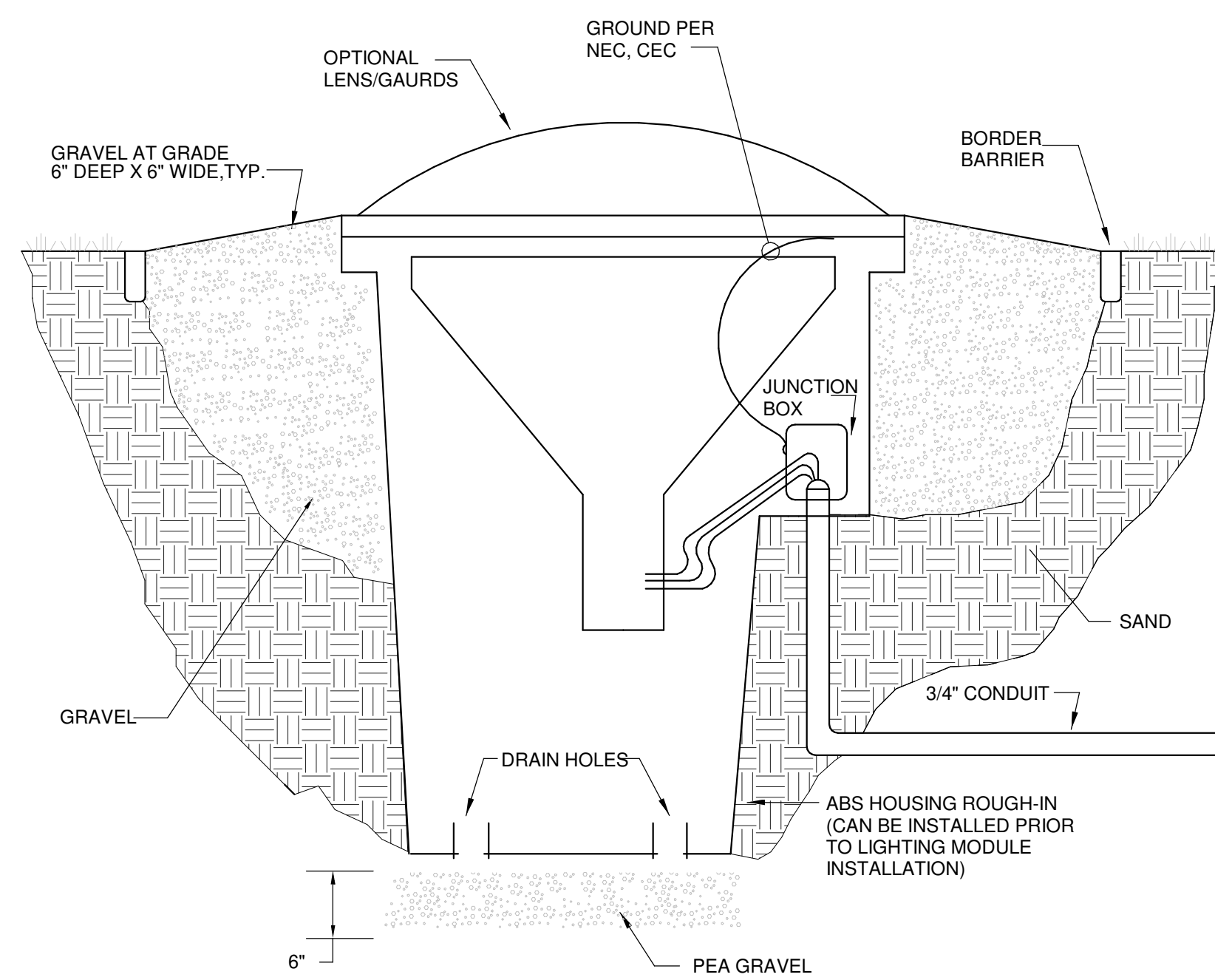

④ LIGHTING DETAIL - IN GROUND LUMINAIRE MOUNTED IN SOIL W/PROTECTIVE COLLAR NTS

Permits:
A21-1888 - Terminal C Garage C
B22-0023 - Terminal C Roadway

DFW
DALLAS
FORT WORTH
INTERNATIONAL
AIRPORT

2330 N INTERNATIONAL PARKWAY
DFW AIRPORT, TX 75261

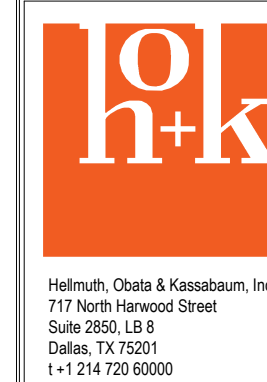
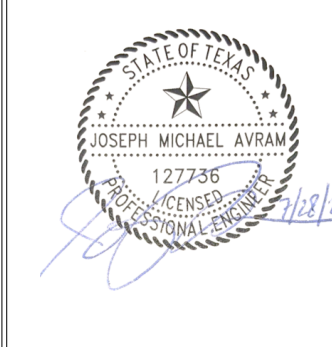

Primera

Hobbs, Clark & Koenigsmann, Inc.
771 North Memorial Street
Suite 2050, LB #
Dallas, TX 75201
1-214-722-6000

Primera Engineers, Ltd.
3000 East 14th
Suite 214
Coppell, TX 75011
1-972-899-8910

PROJECT NUMBER: TFD007

DRAWN BY: BMAY
APPROVED BY: RL/DS
ISSUE DATE: 2022-07-28

**NOT FOR BID OR
CONSTRUCTION**

NO.	DATE	DESCRIPTION
2021-10-29	30% DESIGN	
2022-01-06	70% DESIGN	
2022-08-01	100% DESIGN	
2022-07-28	100% ISSUED FOR PERMIT (IFP)	

PROJECT NUMBER: TFD-007

TERMINAL C GARAGE AND ROADWAYS
ELECTRICAL DETAILS

PERMIT NUMBER: A21-1888

SHEET NUMBER

ES503-900R

SCALE(S) AS NOTED ON THIS SHEET ARE BASED ON A FULL SIZE 30 X 42 SHEET.

**Transformer Pad
Three Phase
Precast Concrete
1500 - 2500 kVA Radial**

205 - 220
09-18

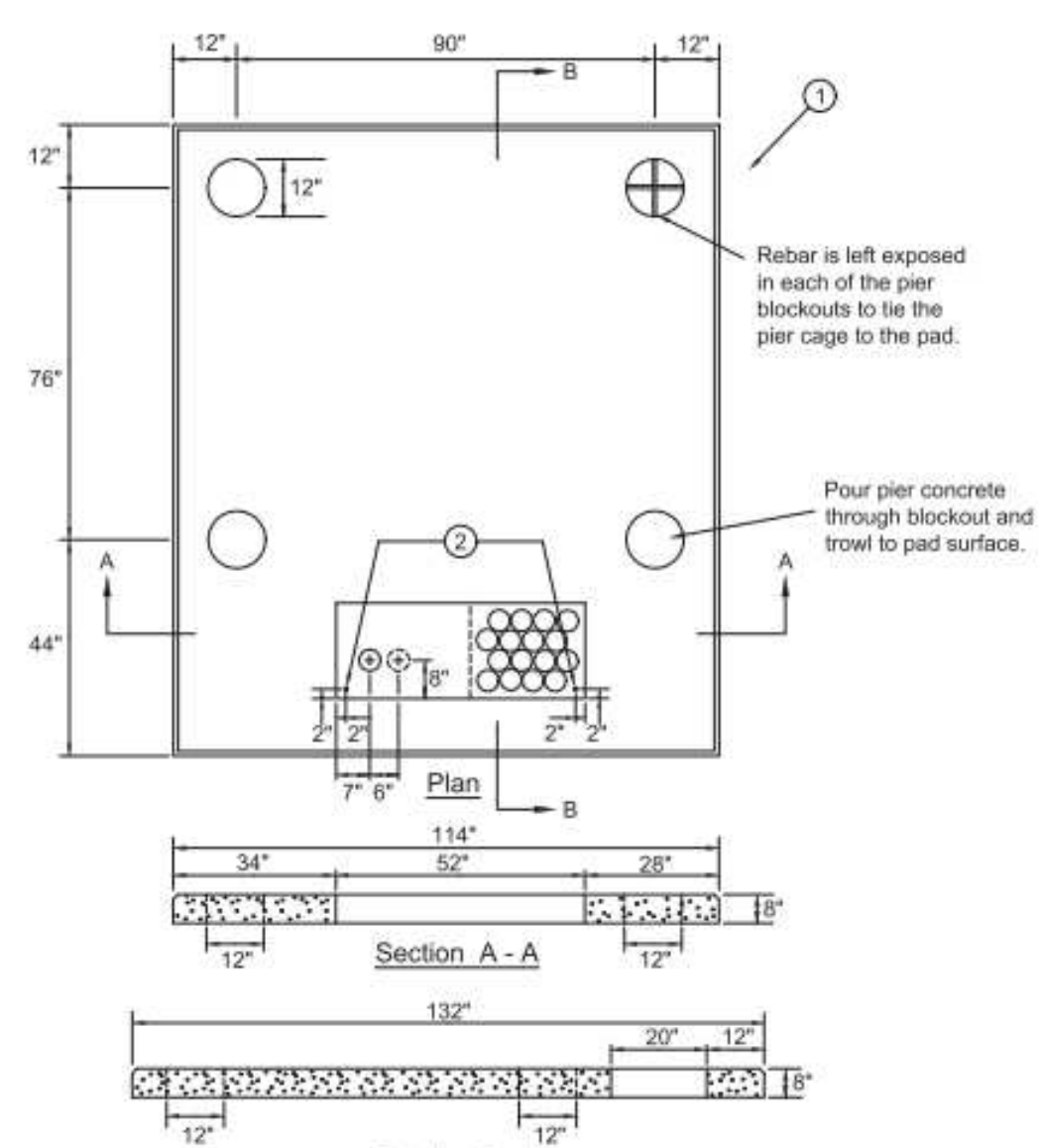

Note:
A. See Standard 205-615 for pier instructions, size and reinforcement cage detail.
Total weight of pad approximately 7050 lbs.

Item	Qty	Description	TSN/Ref	CU	MU
1	1	12' x 12' Precast Concrete Pad, 1500-2500 kVA 3 Phase Transformer	46661	PCP1300K	
2	2	Concrete Reinforcing Steel, #3, 12' x 12', 30' Standard Steel	31721		

Copyright 2018 Oncor Electric Delivery Company. All rights reserved.



Page 1 of 1

**Pier Details For Three Phase
Radial Transformer Precast Pads**

205 - 615
05-19

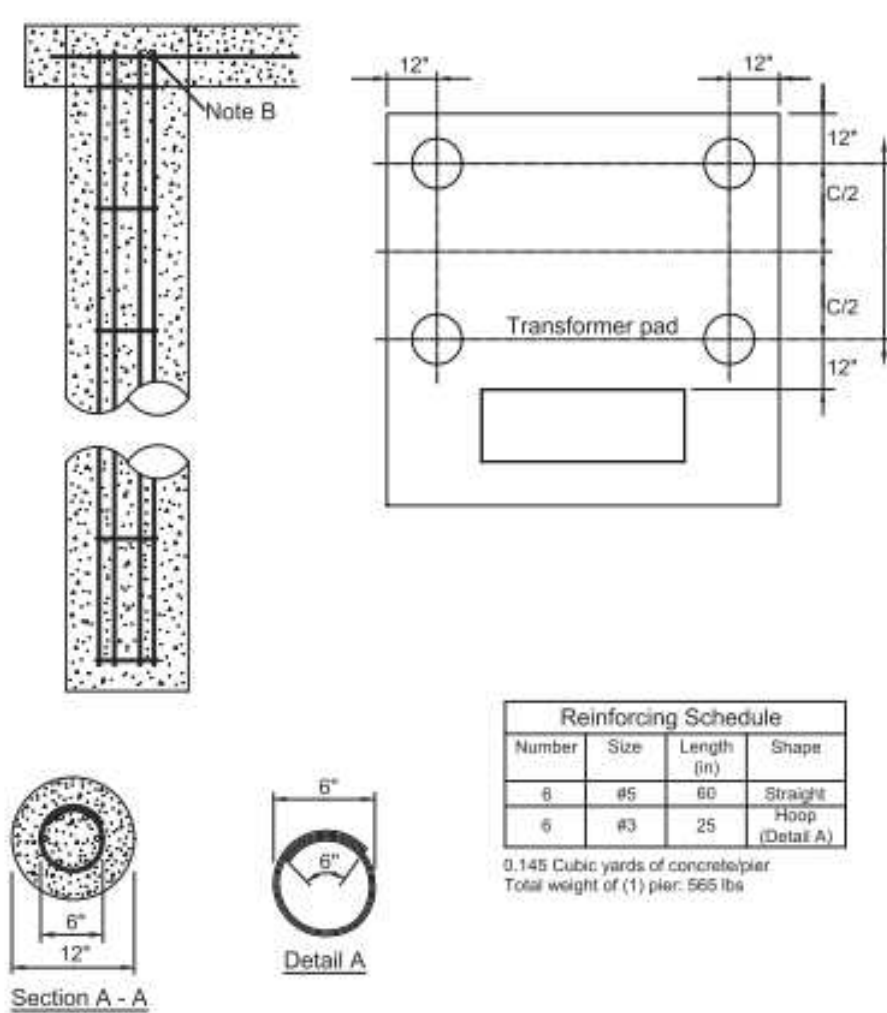

Notes:
A. Pier depth shall be 5 feet below bottom of pad unless rock or other hard surfaces are encountered. If rock or other hard surfaces are encountered prior to a 5 foot depth, pier depth shall extend 6 inches into a hard surface.
B. Precast pads, pier reinforcing is tied to the exposed pad reinforcements revealed inside the cast in blockout holes.
C. Four piers positioned as shown are recommended for all precast concrete pads. Six pier installations will not be necessary as with the larger cast-in-place transformer pads.

Item	Qty	Description	TSN/Ref	CU	MU
1	1	As Req. Concrete			
2	1	As Req. Rebar Reinforcing, #3"	30370		
3	1	As Req. Rebar Reinforcing, #3"	31721		
4	1	As Req. Wire #16 Steel Tie Solid, Bare Black	31739		

Copyright 2018 Oncor Electric Delivery Company. All rights reserved.



Guard Post Installation

205 - 605
09-18

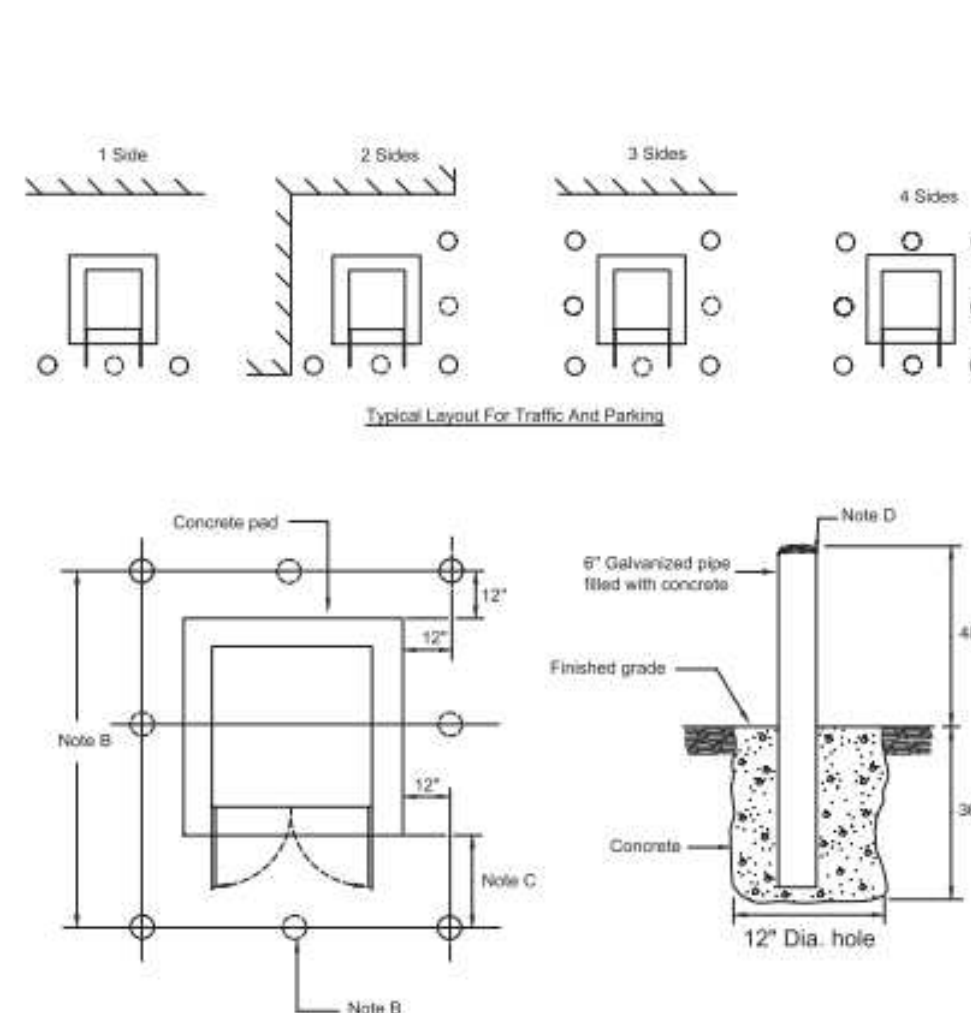

Notes:
A. Install guard post where protection against damage due to vehicular traffic is needed.
B. Distance between posts should not exceed 4 feet. Add additional post where necessary to meet this condition. Verify location of post in front of the transformer to allow for door opening.
C. The distance shall be sufficient to allow full opening of all equipment doors. Contact Distribution Standards to verify dimension.
D. Paint each post "Safety Yellow" after installation for better visibility.

Item	Qty	Description	TSN/Ref	CU	MU
1	1	As Req. Concrete			
2	1	As Req. Galvanized Steel 6"	30370		
3	1	As Req. Concrete, 4" Dia. 6' High	31721		
4	1	As Req. Paint Yellow, Safety 1 Gallon	27828		

Copyright 2018 Oncor Electric Delivery Company. All rights reserved.



**DFW AIRPORT
CONCRETE ENCASED
4" CONDUIT SYSTEMS**

205 - 490b
205 - 490d

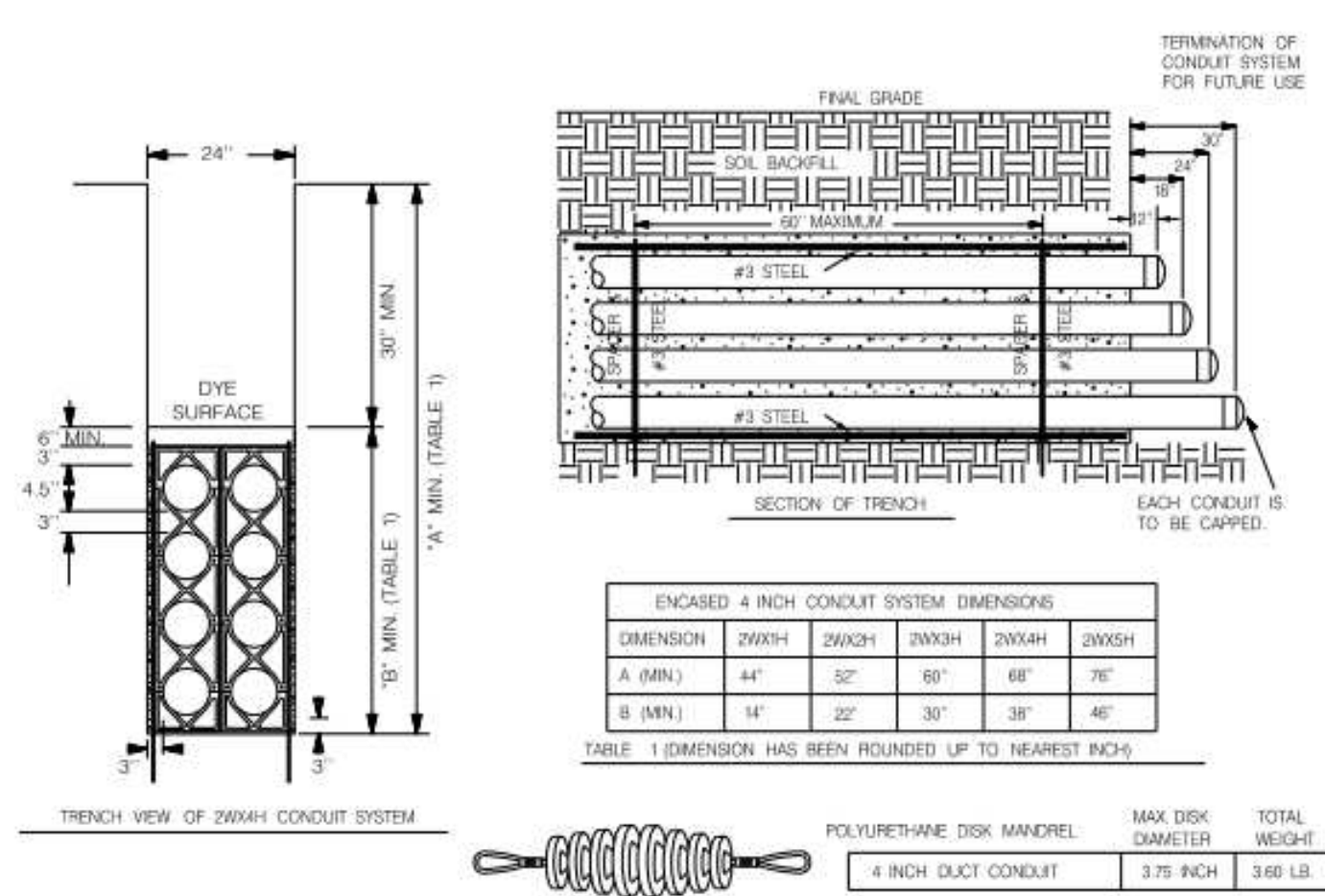

NOTES:
1. CONDUIT FOR CONCRETE ENCASMENTS IS TO BE SOLID WALL PVC SCH-40 AND SHALL NOT BE A CELLULAR CORE PVC PRODUCT.
2. ALL CONCRETE OF THE ENCASMENT IS TO HAVE A COMPRESSIVE TEST STRENGTH OF 3000 PSI AT TWENTY EIGHT DAYS.
3. RADIALLY SPACED 'RANDOM GRAP-LOC' TIES OR EQUAL EVERY 5 FT ALONG ENTIRE LENGTH OF ENCASMENT. NOT SHEET TYPE SPACERS.
4. THE DUCT SPACERS ARE TO PROVIDE 3 INCHES OF VERTICAL AND HORIZONTAL SEPARATION BETWEEN CONDUITS.
5. INSTALL #3 STEEL REINFORCING RODS THROUGH THE INTERNAL VERTICAL CHANNELS AT BOTH OUTER EDGES OF SPACER AND DRIVE RODS INTO EARTH TO ANCHOR ASSEMBLY.
6. INSTALL #3 STEEL REINFORCING ROD HORIZONTALLY IN EACH CORNER ALONG THE TOP AND BOTTOM OF THE ENTIRE 'LENGTH' OF THE ENCASMENT.
7. TIE ALL HORIZONTAL AND VERTICAL RODS TOGETHER WITH #16 STEEL TIE WIRE.
8. ALL CONDUIT SPANS SHOULD SLOPE TOWARD ADJACENT MANHOLES TO PROVIDE DRAINAGE TO A PUMPABLE LOCATION.
9. ALL BACKFILL OF A CONDUIT/TRENCH SHALL BE REPLACED TO A MINIMUM COMPACTION OF 90%.
10. RED POWDER CONCRETE DYE OR RED CONCRETE PAINT IS TO BE PLACED ON TOP OF THE 'PATTERN FINISHED' ENCASMENT.
11. CONDUIT ENDS FOR FUTURE USE (STUBS) ARE TO REMAIN EXPOSED FROM THE ENCASMENT FOR FUTURE RETRIEVAL. THE ENDS SHALL BE CAPPED WATERPROOF.
12. EACH CONDUIT OF A CONCRETE ENCASED DUCT SHALL BE INSPECTED BY PULLING A DISK MANDREL OF PROPER SIZE THRU ITS ENTIRE LENGTH AS SOON AS POSSIBLE AFTER ENCASMENT TO VERIFY INTEGRITY.
13. EACH 4" CONDUIT SHALL HAVE A 800 LB PULL TARE INSTALLED EXCEPT WHERE ENERGIZED EQUIPMENT IS CONNECTED.
14. CONCRETE ENDS WITH A MINIMUM OF 4" OF CONCRETE ON ALL SIDES AND A MINIMUM OF 6" ON TOP.
15. SCH-40 PVC BENDS ARE ALLOWED WITH MINIMUM OF 30' RADIUS.
16. WHEN ENTERING FLAT SURFACES OF PULL BOXES AND MANHOLES DOWEL REBAR ENDS AT MINIMUM 3" IF POSSIBLE INTO SIDES TO PREVENT SHEAR POINTS.
17. FOR CONTINUATION OF DUCT BANKS PROVIDE 45 DEGREE SLOPE FOR THE COOL JOINT TO PREVENT SHEAR POINTS LEAVE A MINIMUM OF 12" OF REBAR FOR OVERLAPPING.
18. CONDUIT JOINTS SHALL BE STAGGERED AND CONSTRUCTED SO THAT A MANHOLE CAN BE PULLED THROUGH ITS ENTIRE LENGTH. RE ALLOW A MINIMUM OF 12 HOURS BEFORE BACKFILLING CONCRETE ENCASED DUCT BANKS (SEE 20).
19. ALL 5KV CIVIL INFRASTRUCTURE IS OWNED AND MAINTAINED BY DFW AIRPORT. ALL 5KV ELECTRICAL SYSTEMS ARE OWNED AND MAINTAINED BY ONCOR ELECTRIC DELIVERY.

APPROVED BY ONCOR

**Maximum Number of Secondary
Conduits and Cables for
Padmounted Transformers**

209 - 420
10-17

Three-Phase Transformer Size (kVA)	Maximum Number of 4" PVC Conduits 208Y/120 480Y/277	Maximum Number of Cables Including the Neutral 208Y/120 480Y/277
75 - 150	6	24
225 - 300	6	24
500	6	32
750	12	48
1000	16	64
1500	-	48
2000	-	64
2500	-	64

Notes:
1. If the number of runs installed by the customer is more than the maximum shown in the table, a connection enclosure with pad may be required.
2. For single-phase transformer installations see paragraph 1.7 in drawing 207-010.
3. The maximum cable size is 1000 kcmil. (See paragraph 1.6 of 207-010.)

Copyright 2018 Oncor Electric Delivery Company. All rights reserved.

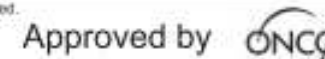

**DFW AIRPORT
CONCRETE ENCASED
6" CONDUIT SYSTEMS**

205 - 490a

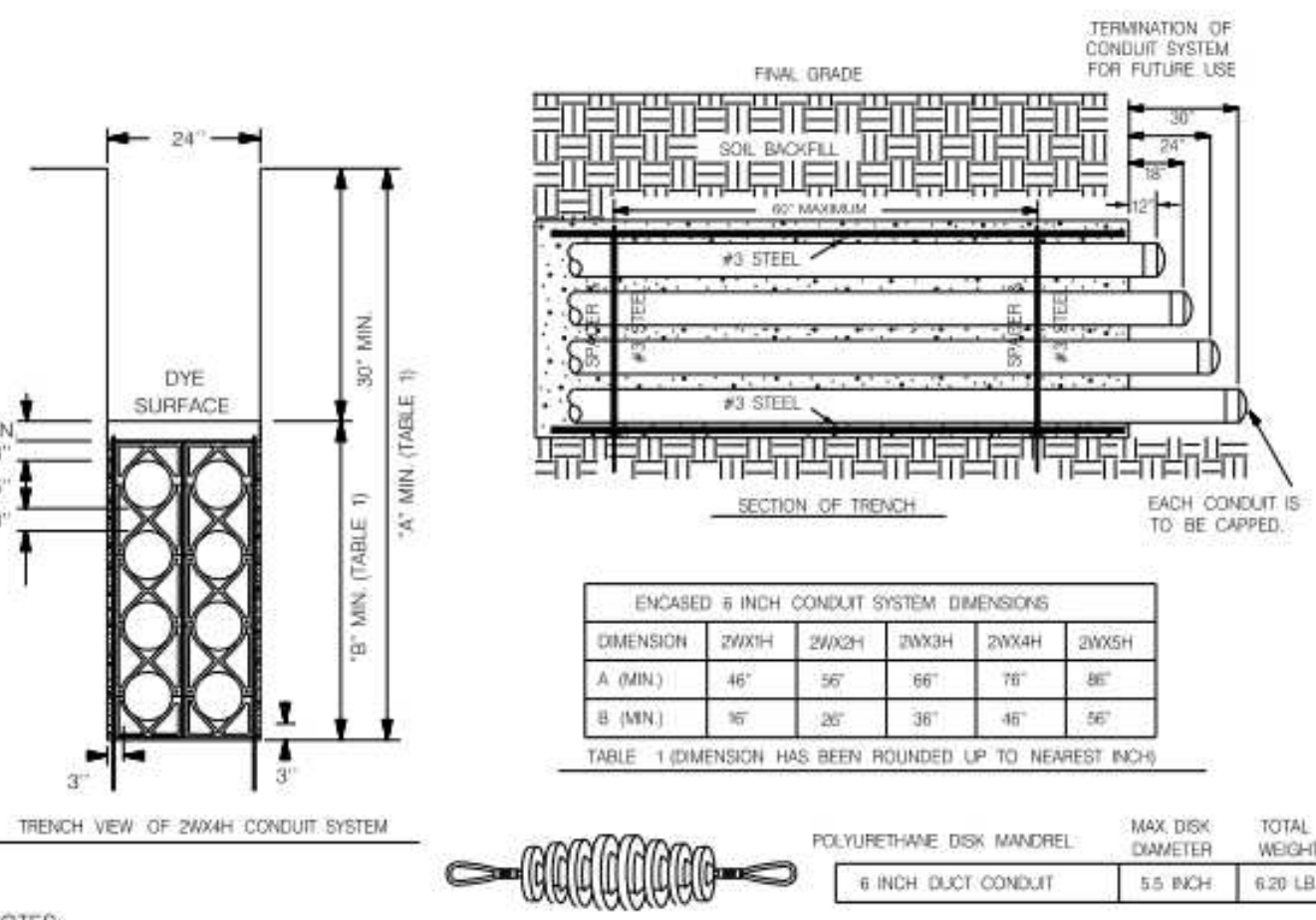

NOTES:
1. CONDUIT FOR CONCRETE ENCASMENTS IS TO BE SOLID WALL PVC SCH-40 AND SHALL NOT BE A CELLULAR CORE PVC PRODUCT.
2. ALL CONCRETE OF THE ENCASMENT IS TO HAVE A COMPRESSIVE TEST STRENGTH OF 3000 PSI AT TWENTY EIGHT DAYS.
3. RADIALLY SPACED 'RANDOM GRAP-LOC' TIES OR EQUAL EVERY 5 FT ALONG ENTIRE LENGTH OF ENCASMENT. NOT SHEET TYPE SPACERS.
4. THE DUCT SPACERS ARE TO PROVIDE 3 INCHES OF VERTICAL AND HORIZONTAL SEPARATION BETWEEN CONDUITS.
5. INSTALL #3 STEEL REINFORCING RODS THROUGH THE INTERNAL VERTICAL CHANNELS AT BOTH OUTER EDGES OF SPACER AND DRIVE RODS INTO EARTH TO ANCHOR ASSEMBLY.
6. INSTALL #3 STEEL REINFORCING ROD HORIZONTALLY IN EACH CORNER ALONG THE TOP AND BOTTOM OF THE ENTIRE 'LENGTH' OF THE ENCASMENT.
7. TIE ALL HORIZONTAL AND VERTICAL RODS TOGETHER WITH #16 STEEL TIE WIRE.
8. ALL CONDUIT SPANS SHOULD SLOPE TOWARD ADJACENT MANHOLES TO PROVIDE DRAINAGE TO A PUMPABLE LOCATION.
9. ALL BACKFILL OF A CONDUIT/TRENCH SHALL BE REPLACED TO A MINIMUM COMPACTION OF 90%.
10. RED POWDER CONCRETE DYE OR RED CONCRETE PAINT IS TO BE PLACED ON TOP OF THE 'PATTERN FINISHED' ENCASMENT.
11. CONDUIT ENDS FOR FUTURE USE (STUBS) ARE TO REMAIN EXPOSED FROM THE ENCASMENT FOR FUTURE RETRIEVAL. THE ENDS SHALL BE CAPPED WATERPROOF.
12. EACH CONDUIT OF A CONCRETE ENCASED DUCT SHALL BE INSPECTED BY PULLING A DISK MANDREL OF PROPER SIZE THRU ITS ENTIRE LENGTH AS SOON AS POSSIBLE AFTER ENCASMENT TO VERIFY INTEGRITY.
13. EACH 6" CONDUIT SHALL HAVE A 800 LB PULL TARE INSTALLED EXCEPT WHERE ENERGIZED EQUIPMENT IS CONNECTED.
14. CONCRETE ENDS WITH A MINIMUM OF 4" OF CONCRETE ON ALL SIDES AND A MINIMUM OF 6" ON TOP.
15. SCH-40 PVC BENDS ARE ALLOWED WITH MINIMUM OF 30' RADIUS.
16. WHEN ENTERING FLAT SURFACES OF PULL BOXES AND MANHOLES DOWEL REBAR ENDS AT MINIMUM 3" IF POSSIBLE INTO SIDES TO PREVENT SHEAR POINTS.
17. FOR CONTINUATION OF DUCT BANKS PROVIDE 45 DEGREE SLOPE FOR THE COOL JOINT TO PREVENT SHEAR POINTS LEAVE A MINIMUM OF 12" OF REBAR FOR OVERLAPPING.
18. CONDUIT JOINTS SHALL BE STAGGERED AND CONSTRUCTED SO THAT A MANHOLE CAN BE PULLED THROUGH ITS ENTIRE LENGTH. RE ALLOW A MINIMUM OF 12 HOURS BEFORE BACKFILLING CONCRETE ENCASED DUCT BANKS (SEE 20).
19. ALL 5KV CIVIL INFRASTRUCTURE IS OWNED AND MAINTAINED BY DFW AIRPORT. ALL 5KV ELECTRICAL SYSTEMS ARE OWNED AND MAINTAINED BY ONCOR ELECTRIC DELIVERY.

APPROVED BY ONCOR

**Precast Deep Window Pad For 25 kV
Dead Front SF6 Insulated Switchgear**

205 - 710
09-18

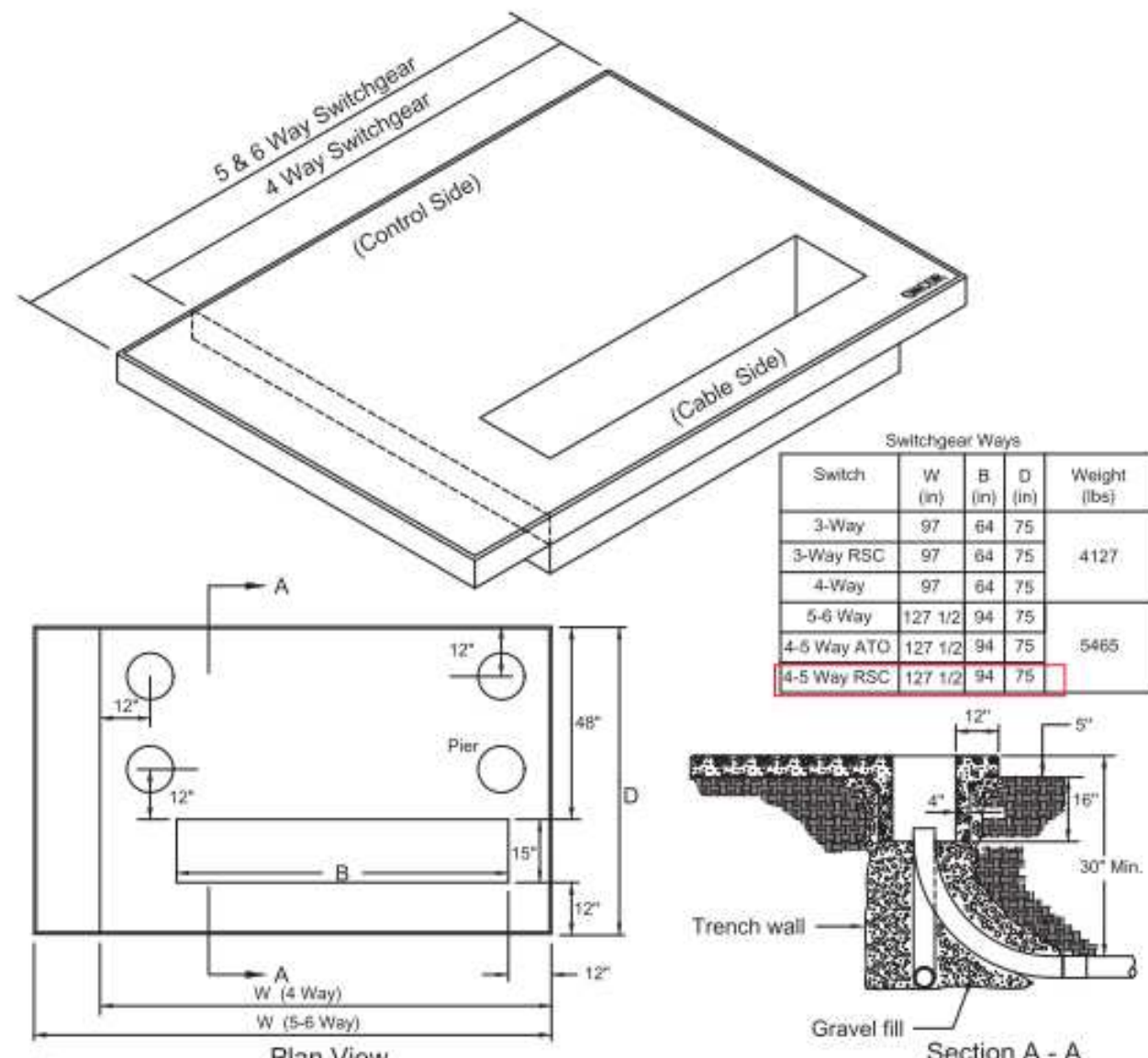

Notes:
A. To prevent settling and improve pad stabilization add a minimum of 14 inches of medium size gravel fill to bottom and around sides.
B. To help prevent wildlife entry, fill in the windows around the conduits with base gravel to allow for drainage.
C. Each pad will include two lifting points rated at 2000 lbs each. Total pad weights are shown in the table above.
D. For clearances on all sides of the switchgear see Standards Section 202.
E. Conduit shall not extend more than 2 inches above the bottom of the deep well.
F. For pads plumbed into manhole/duct banks, install a 3 inch PVC communication/control conduit from manhole to front right corner of load side conduit window opening of the pad.
G. The need for pier installation is subject to soil conditions and is at the designer and/or civil inspector's discretion.

Item	Qty	Description	TSN/Ref	CU	MU
1	1	Pad, Precast, 20' Deep Window, 3 - 4 Way Dead Front Switchgear	46020	PRDW20DF	
2	1	Pad, Precast, 20' Deep Window, 5 - 6 Way Dead Front Switchgear	46021	PRDW20DF6	

Copyright 2018 Oncor Electric Delivery Company. All rights reserved.



**Conduit Locations
Dead Front Pad Mount
25 kV SF6 Insulated Switchgear
(RSC Operation)**

205 - 720
09-18

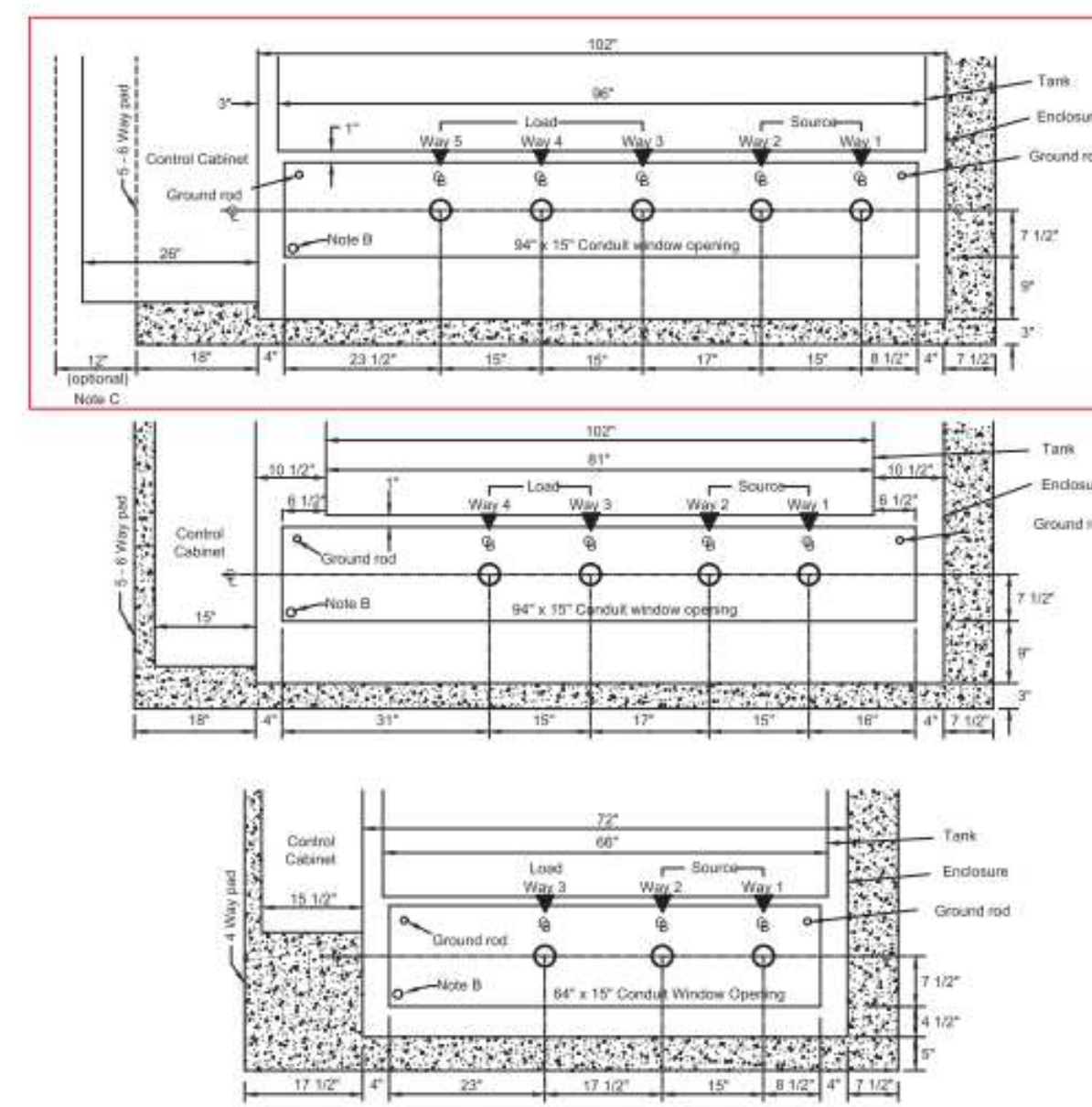

Notes:
A. Conduit shall be centered on center bushing position of each switched way. If a spare conduit is required, both shall be centered as shown on center bushing position of each switched way.
B. For pads plumbed into duct banks, install one 3 inch communication/control conduit from the manhole to the front left corner of the conduit window opening of the pad.
C. To better protect the oversized control cabinet from damage, field pour a concrete pad extension a minimum of 12' x 75' x 6" and down into the precast pad approximately every 12 inches to prevent separation.

Copyright 2018 Oncor Electric Delivery Company. All rights reserved.



**Pier Detail for 15/25 kV
Live Front / Dead Front
Switchgear Pads and Secondary Enclosure**

205 - 620
09-18

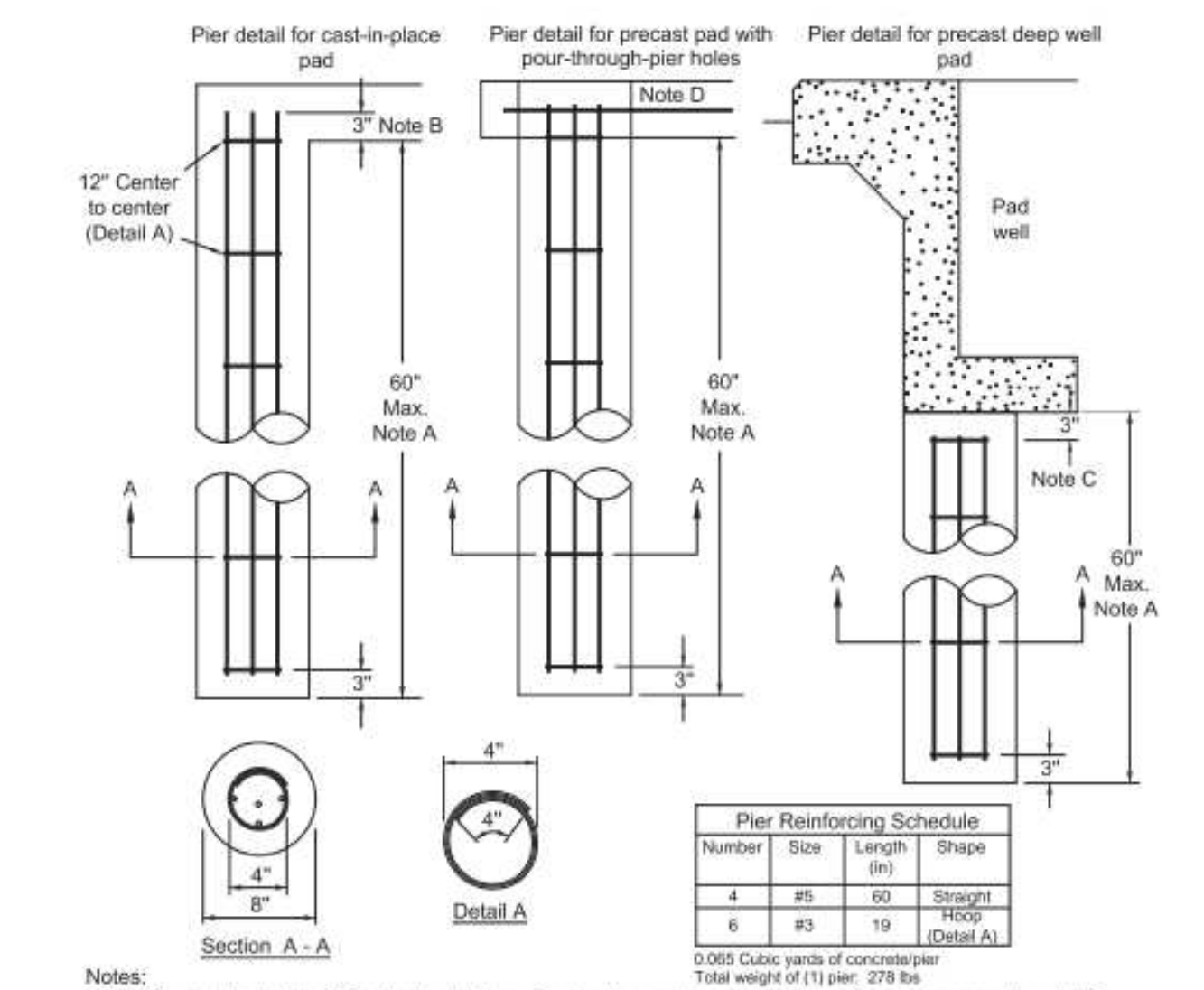

Notes:
A. Pier depth shall be 5 feet below bottom of pad unless rock or other hard surfaces are encountered. If rock or other hard surfaces are encountered prior to a 5 foot depth, pier depth shall extend 6 inches into a hard surface.
B. For cast-in-place pads, the pier reinforcing rods are to extend 3 inches into pad.
C. For precast deep well pads, the pier reinforcing rods are to stop short of the edges of the concrete by 3 inches.
D. For precast pads with pour through pier holes, the pier reinforcing rods are tied to the reinforcement steel cast into the pad.

Item	Qty	Description	TSN/Ref	CU	MU
1	1	As Req. Concrete			
2	1	As Req. Rebar Reinforcing, #3"	30370		
3	1	As Req. Rebar Reinforcing, #3"	31721		
4	1	As Req. Wire #16 Steel Tie Solid Bare Black	31739		

Copyright 2018 Oncor Electric Delivery Company. All rights reserved.



DALLAS
FORT WORTH
INTERNATIONAL
AIRPORT

2330 N INTERNATIONAL PARKWAY
DFW AIRPORT, TX 75261



Primera

Heidrich, Gluck & Kossmann, Inc.
771 North Nevada Street
Suite 2050, LB #
Dallas, TX 75201
1-214-729-6000

DRAWN BY: B/MAY
APPROVED BY: R/LDS
ISSUE DATE: 2022-07-28

NOT FOR BID OR
CONSTRUCTION

NO.	DATE	DESCRIPTION
2021-02-23	30% DESIGN	
2022-01-06	70% DESIGN	
2022-05-01	100% DESIGN	
2022-07-28	100% ISSUED FOR PERMIT (IFP)	

PROJECT NUMBER: TFD-007

TERMINAL C GARAGE AND ROADWAYS
ONCOR DETAILS

SHEET NUMBER
ES504-900R

PERMIT NUMBER: A21-1888
SCALE(S) AS NOTED ON THIS SHEET ARE BASED ON A FULL SIZE 30 X 42 SHEET.

Permits:
A21-1888 - Terminal C Garage C
B22-0023 - Terminal C Roadway

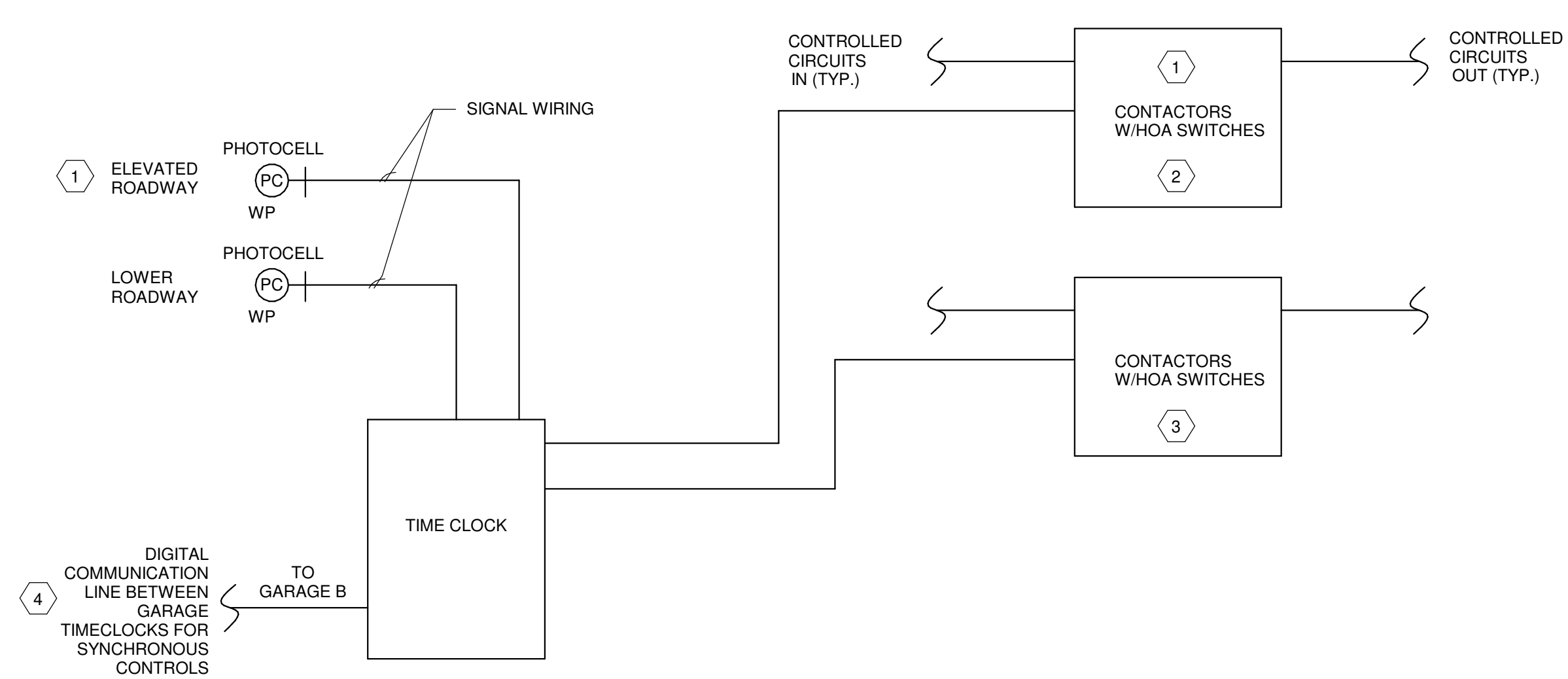

- NOTES:
1. THIS DETAIL IS TYPICAL FOR LIGHTING CONTROLS. ALL CONTROL DEVICES SHALL BE PROGRAMMED TO COMPLY WITH IECC 2015 REQUIREMENTS.
 2. TIME CLOCK SHALL INTERFACE WITH PHOTOCELL FOR ON/OFF CONTROL.
 3. TIME CLOCK SHALL BE ELECTRONIC WITH ASTRONOMIC SETTINGS.
 4. TIME CLOCK SHALL HAVE MULTI-CHANNEL CONTROLS.
 5. TIME CLOCK SHALL BE FULLY COMPLIANT WITH ALL IECC 2015 REQUIREMENTS.

- DETAIL KEYED NOTES:
- 1 LOCATED ON ELEVATED ROAWAY LEVEL.
 - 2 CONTACTORS FOR (4) POLES, MINIMUM.
 - 3 PROVIDE (2) SEPARATE CONTACTORS: 1 FOR EM AND 1 FOR NORMAL POWER. EM SHALL BE (4) POLES, MINIMUM. NORMAL SHALL BE (16) POLES, MINIMUM.
 - 4 ROUTE INTERCONNECTION BETWEEN GARAGES ALONG SIDE ELEVATED ROAD. CONTROL SIGNALING SHALL BE IN DEDICATED CONDUIT.

1 LIGHTING CONTROLS RISER DIAGRAM - GARAGE A
NTS

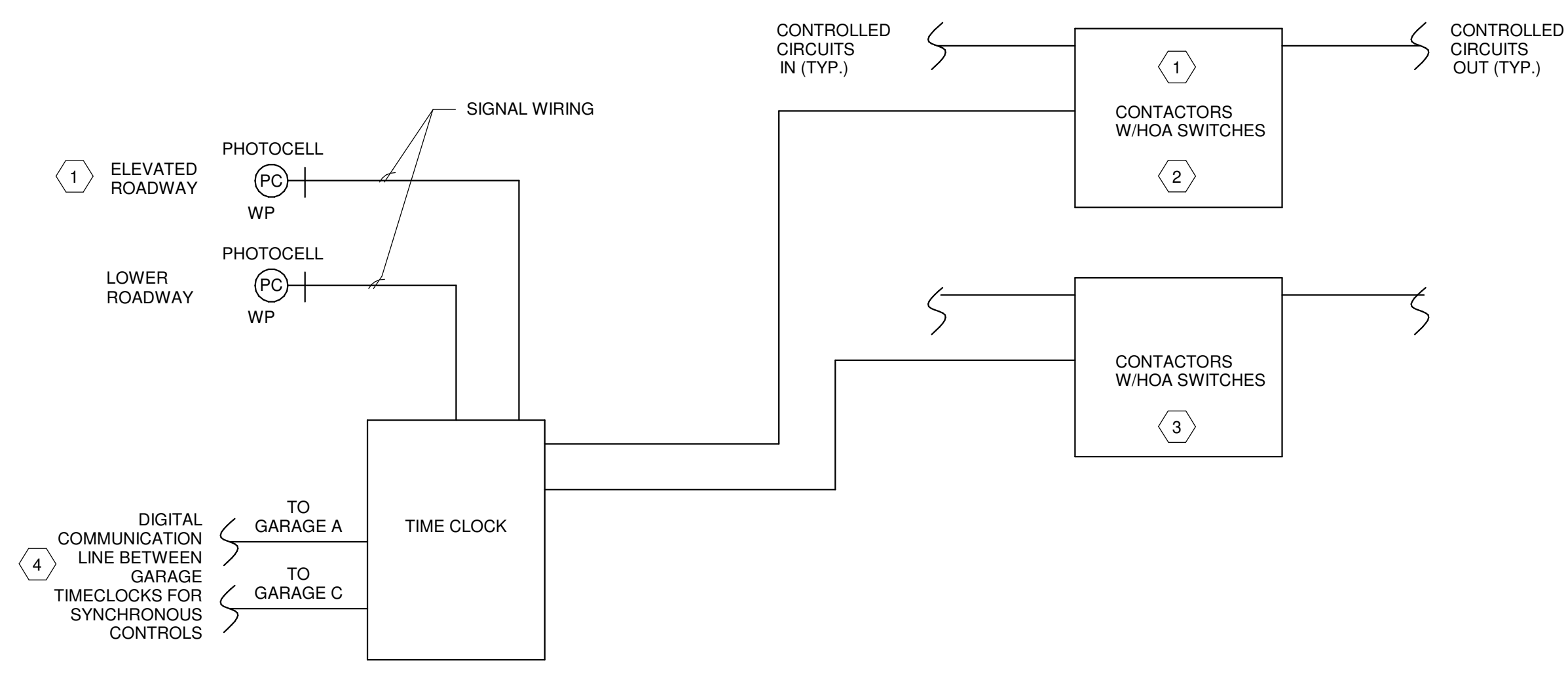

- NOTES:
1. THIS DETAIL IS TYPICAL FOR LIGHTING CONTROLS. ALL CONTROL DEVICES SHALL BE PROGRAMMED TO COMPLY WITH IECC 2015 REQUIREMENTS.
 2. TIME CLOCK SHALL INTERFACE WITH PHOTOCELL FOR ON/OFF CONTROL.
 3. TIME CLOCK SHALL BE ELECTRONIC WITH ASTRONOMIC SETTINGS.
 4. TIME CLOCK SHALL HAVE MULTI-CHANNEL CONTROLS.
 5. TIME CLOCK SHALL BE FULLY COMPLIANT WITH ALL IECC 2015 REQUIREMENTS.

- DETAIL KEYED NOTES:
- 1 LOCATED ON ELEVATED ROAWAY LEVEL.
 - 2 CONTACTORS FOR (4) POLES, MINIMUM.
 - 3 PROVIDE (2) SEPARATE CONTACTORS: 1 FOR EM AND 1 FOR NORMAL POWER. EM SHALL BE (4) POLES, MINIMUM. NORMAL SHALL BE (16) POLES, MINIMUM.
 - 4 ROUTE INTERCONNECTION BETWEEN GARAGES ALONG SIDE ELEVATED ROAD. CONTROL SIGNALING SHALL BE IN DEDICATED CONDUIT.

2 LIGHTING CONTROLS RISER DIAGRAM - GARAGE B
NTS

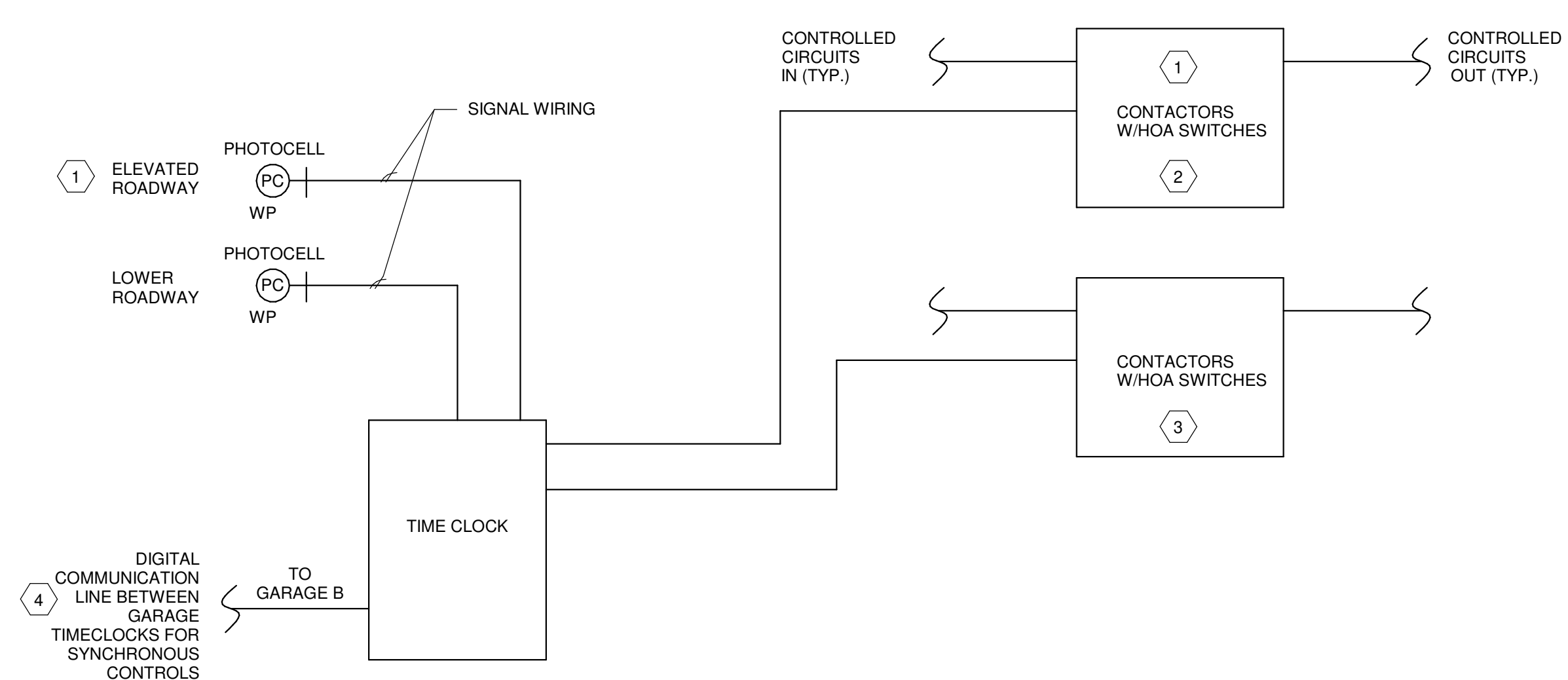

- NOTES:
1. THIS DETAIL IS TYPICAL FOR LIGHTING CONTROLS. ALL CONTROL DEVICES SHALL BE PROGRAMMED TO COMPLY WITH IECC 2015 REQUIREMENTS.
 2. TIME CLOCK SHALL INTERFACE WITH PHOTOCELL FOR ON/OFF CONTROL.
 3. TIME CLOCK SHALL BE ELECTRONIC WITH ASTRONOMIC SETTINGS.
 4. TIME CLOCK SHALL HAVE MULTI-CHANNEL CONTROLS.
 5. TIME CLOCK SHALL BE FULLY COMPLIANT WITH ALL IECC 2015 REQUIREMENTS.

- DETAIL KEYED NOTES:
- 1 LOCATED ON ELEVATED ROAWAY LEVEL.
 - 2 CONTACTORS FOR (4) POLES, MINIMUM.
 - 3 PROVIDE (2) SEPARATE CONTACTORS: 1 FOR EM AND 1 FOR NORMAL POWER. EM SHALL BE (4) POLES, MINIMUM. NORMAL SHALL BE (16) POLES, MINIMUM.
 - 4 ROUTE INTERCONNECTION BETWEEN GARAGES ALONG SIDE ELEVATED ROAD. CONTROL SIGNALING SHALL BE IN DEDICATED CONDUIT.

3 LIGHTING CONTROLS RISER DIAGRAM - GARAGE C
NTS

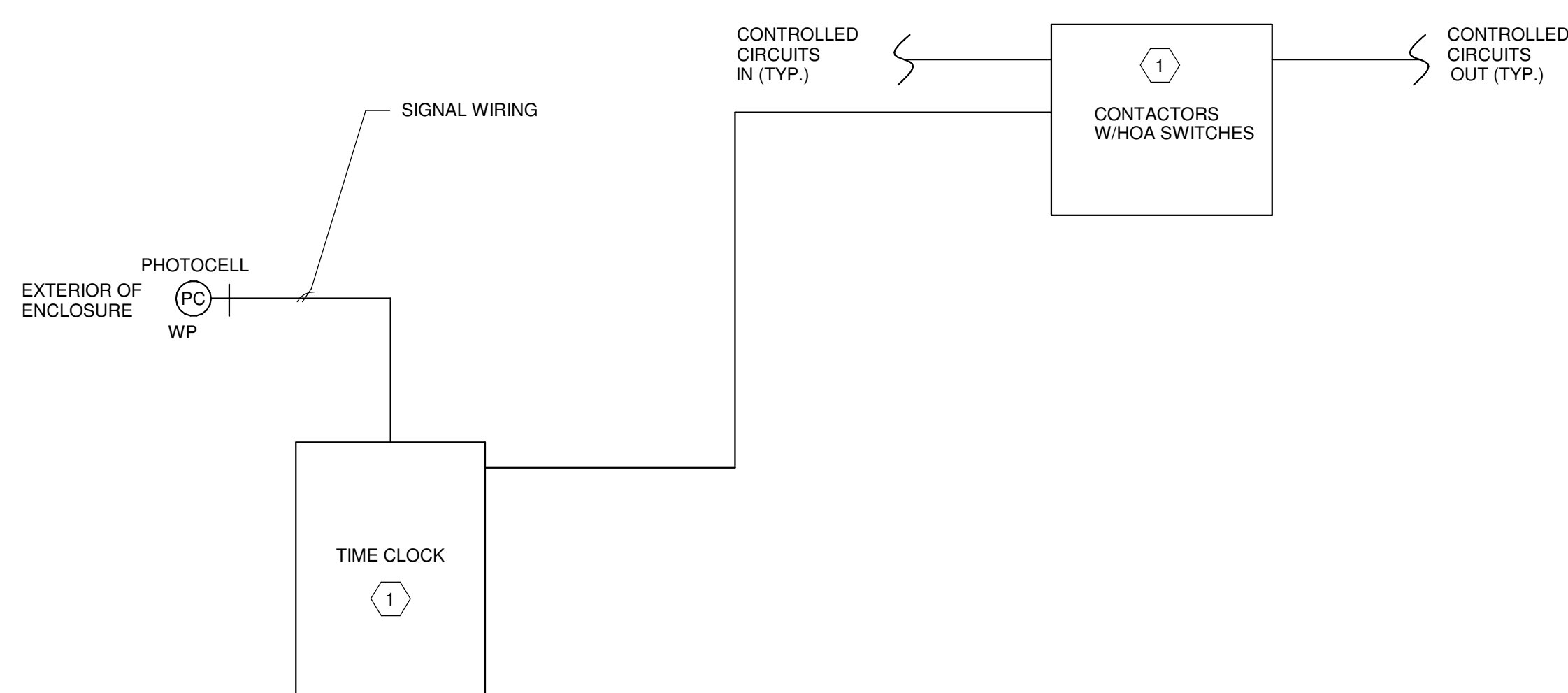

- NOTES:
1. THIS DETAIL IS TYPICAL FOR LIGHTING CONTROLS. ALL CONTROL DEVICES SHALL BE PROGRAMMED TO COMPLY WITH IECC 2015 REQUIREMENTS.
 2. TIME CLOCK SHALL INTERFACE WITH PHOTOCELL FOR ON/OFF CONTROL.
 3. TIME CLOCK SHALL BE ELECTRONIC WITH ASTRONOMIC SETTINGS.
 4. TIME CLOCK SHALL HAVE MULTI-CHANNEL CONTROLS.
 5. TIME CLOCK SHALL BE FULLY COMPLIANT WITH ALL IECC 2015 REQUIREMENTS.

- DETAIL KEYED NOTES:
- 1 LOCATED NEAR PANEL LP-1A IN ENCLOSURE A/B & NEAR LP-1C IN ENCLOSURE C.

4 LIGHTING CONTROLS RISER DIAGRAM - ENCLOSURE EXTERIOR
NTS

Permits:
A21-1883 - Terminal C Garage C
B22-0021 - Terminal C Garage B
B22-0022 - Terminal C Garage A
B22-0023 - Terminal C Roadway



2330 N INTERNATIONAL PARKWAY
DFW AIRPORT, TX 75261

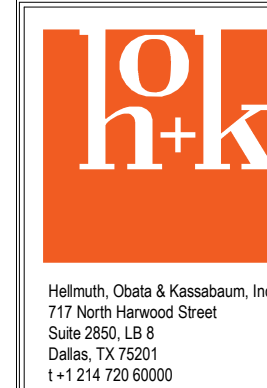

Heidolph, Clark & Rosenbaum, Inc.
777 North Meadows Street
Suite 2050, LB #
Dallas, TX 75201
+1 214 722 6000

Primera Engineers, Ltd.
3000 East 1st
Suite 214
Coppell, TX 75011
+1 972 899 9910

PROJECT NUMBER: TFD007

DRAWN BY: BM/AY
APPROVED BY: RL/DS
ISSUE DATE: 2022-07-28

NOT FOR BID OR
CONSTRUCTION

NO.	DATE	DESCRIPTION
2021-10-29	30% DESIGN	
2022-01-06	70% DESIGN	
2022-08-01	100% DESIGN	
2022-07-28	100% ISSUED FOR PERMIT (IFP)	

TERMINAL C GARAGE AND ROADWAYS
ELECTRICAL LIGHTING RISERS

PROJECT NUMBER: TFD-007

PERMIT NUMBER: A21-1883

SHEET NUMBER
ES603-900R

SCALE(S) AS NOTED ON THIS SHEET ARE BASED ON A FULL SIZE 30 X 42 SHEET.

LUMINAIRE SCHEDULE														
TAG	DESCRIPTION	MANUFACTURER	MODEL	DRIVER TYPE	LAMP TYPE	CCT	MIN. CRI	VOLTAGE	FIXTURE WATTS	DELIVERED LUMENS	BUG RATING	MOUNTING	FINISH	REMARKS
F1	COBRA HEAD ROADWAY LUMINAIRE, MOUNTED ON CUSTOM POLE (GARAGES A,B) UL WET LOCATION AND EXTERIOR RATED, DLC LISTED	SIGNIFY LUMEC OR ENGINEER APPROVED EQUAL	ROADFOCUS RFM-160W48LED-3K-G2-R2S-UNV POLE: 21' ROUND, TAPERED STEEL POLE, VALMONT DS90, DESIGNATION #xxxx POLE ARM: 6' ROUND, TAPERED STEEL, 5 YR WARRANTY	INTEGRAL	LED ARRAY	3000K	70	UNIVERSAL	161	19,092	B3-U0-G2	POLE	GALVANIZED, SILVER	FIXTURE SHALL BE 50' ABOVE ROADWAY. POLE HEIGHT SHALL VARY BASED ON GARAGE ELEVATION. SEE NOTE #9 AND #10. FINISH/COLOR PER ARCHITECT. 5 YR WARRANTY POLE FINISH
F1A	COBRA DUAL-HEADED ROADWAY LUMINAIRE, MOUNTED ON CUSTOM POLE (GARAGE A,B) UL WET LOCATION AND EXTERIOR RATED, DLC LISTED	SIGNIFY LUMEC OR ENGINEER APPROVED EQUAL	ROADFOCUS RFM-160W48LED-3K-G2-4-UNV (FACING RAMPS) ROADFOCUS RFM-160W48LED-3K-G2-4-UNV (FACING RAMPS) POLE: 21' ROUND, TAPERED STEEL POLE, VALMONT DS90, DESIGNATION #xxxx POLE ARM: 6' ROUND, TAPERED STEEL, VALMONT, 5 YR WARRANTY	INTEGRAL	LED ARRAY	3000K	70	UNIVERSAL	161 EACH HEAD	19,092 18,187	B3-U0-G2 B3-U0-G3	POLE	GALVANIZED, SILVER	FIXTURE SHALL BE 50' ABOVE ROADWAY. POLE HEIGHT SHALL VARY BASED ON GARAGE ELEVATION. SEE NOTE #9 AND #10. FINISH/COLOR PER ARCHITECT. 5 YR WARRANTY POLE FINISH.
F1B	COBRA HEAD ROADWAY LUMINAIRE MOUNTED ON CUSTOM POLE FACING RAMPS (GARAGE A,B) UL WET LOCATION AND EXTERIOR RATED, DLC LISTED	SIGNIFY LUMEC OR ENGINEER APPROVED EQUAL	ROADFOCUS RFM-160W48LED-3K-G2-4-UNV POLE: 21' ROUND, TAPERED STEEL POLE, VALMONT DS90, DESIGNATION #xxxx POLE ARM: 6' ROUND, TAPERED STEEL, VALMONT, 5 YR WARRANTY	INTEGRAL	LED ARRAY	3000K	70	UNIVERSAL	161	18,187	B3-U0-G3	POLE	GALVANIZED, SILVER	FIXTURE SHALL BE 50' ABOVE ROADWAY. POLE HEIGHT SHALL VARY BASED ON GARAGE ELEVATION. SEE NOTE #9 AND #10. FINISH/COLOR PER ARCHITECT. 5 YR WARRANTY POLE FINISH
F2	NOT USED	--	--											
F3	COBRA HEAD ROADWAY LUMINAIRE, MOUNTED ON CUSTOM POLE (GARAGE C) UL WET LOCATION AND EXTERIOR RATED, DLC LISTED	SIGNIFY LUMEC OR ENGINEER APPROVED EQUAL	ROADFOCUS RFM-160W48LED-3K-G2-R2S-UNV POLE: 9'-0" ROUND, TAPERED STEEL POLE, VALMONT DS90, DESIGNATION #xxxx POLE ARM: 6' ROUND, TAPERED STEEL, VALMONT 5 YR WARRANTY	INTEGRAL	LED ARRAY	3000K	70	UNIVERSAL	161	19,092	B3-U0-G2	POLE	GALVANIZED, SILVER	FIXTURE SHALL BE 50' ABOVE ROADWAY. POLE HEIGHT SHALL VARY BASED ON GARAGE ELEVATION. SEE NOTE #9 AND #10. FINISH/COLOR PER ARCHITECT. 5 YR WARRANTY POLE FINISH
F3A	COBRA DUAL-HEADED ROADWAY LUMINAIRE, MOUNTED ON CUSTOM POLE (GARAGE C) UL WET LOCATION AND EXTERIOR RATED, DLC LISTED	SIGNIFY LUMEC OR ENGINEER APPROVED EQUAL	ROADFOCUS RFM-160W48LED-3K-G2-R2S-UNV POLE: 9'-0" ROUND, TAPERED STEEL POLE, VALMONT DS90, DESIGNATION #xxxx POLE ARM: 6' ROUND, TAPERED STEEL, VALMONT, 5 YR WARRANTY	INTEGRAL	LED ARRAY	3000K	70	UNIVERSAL	161 EACH HEAD	19,092	B3-U0-G2	POLE	GALVANIZED, SILVER	FIXTURE SHALL BE 50' ABOVE ROADWAY. POLE HEIGHT SHALL VARY BASED ON GARAGE ELEVATION. SEE NOTE #9 AND #10. FINISH/COLOR PER ARCHITECT. 5 YR WARRANTY POLE FINISH
F3B	COBRA HEAD ROADWAY LUMINAIRE, MOUNTED ON CUSTOM POLE FACING RAMPS (GARAGE C) UL WET LOCATION AND EXTERIOR RATED, DLC LISTED	SIGNIFY LUMEC OR ENGINEER APPROVED EQUAL	ROADFOCUS RFM-160W48LED-3K-G2-4-UNV POLE: 9'-0" ROUND, TAPERED STEEL POLE, VALMONT DS90, DESIGNATION #xxxx POLE ARM: 6' ROUND, TAPERED STEEL, 5 YR WARRANTY	INTEGRAL	LED ARRAY	3000K	70	UNIVERSAL	161	18,187	B3-U0-G3	POLE	GALVANIZED, SILVER	FIXTURE SHALL BE 50' ABOVE ROADWAY. POLE HEIGHT SHALL VARY BASED ON GARAGE ELEVATION. SEE NOTE #9 AND #10. FINISH/COLOR PER ARCHITECT. 5 YR WARRANTY POLE FINISH.
F4	LED WALLPACK, DIE-CAST ALUMINUM, GLASS LENS, SURFACE MOUNTED, HIGH-TEMPERATURE SILICONE GASKETS, 70 CRI, 15,000 LUMENS UL WET LOCATION AND EXTERIOR RATED, DLC LISTED	RAB LIGHTING OR ENGINEER APPROVED EQUAL	WP3LED-150L-750-W-U	INTEGRAL	LED	4000K	73	UNIVERSAL	110	15,150		SURFACE WALL		
F5	SIGNAGE COMPACT LED FLOOD LIGHT, 80 DEGREE WIDE FLOOD 7x7 DISTRIBUTION, 12,000 LUMENS, *ARM MOUNT UL WET LOCATION AND EXTERIOR RATED	GE CURRENT OR ENGINEER APPROVED EQUAL	EVOLVE EFC101-0-12-77-7-30-X-X-XX	INTEGRAL	LED	3000K	70	UNIVERSAL	88	11,500		SURFACE		*RE-USE EXISTING ARM MOUNT
F6	4' INDUSTRIAL LED LINEAR STRIP, VAPORPROOF UL WET LOCATION AND EXTERIOR RATED, DLC LISTED	SIGNIFY OR ENGINEER APPROVED EQUAL	VAPORLUME LED V3W-435L-830-UNV	INTEGRAL	LED	3000K	80	UNIVERSAL	25	3,500		SURFACE		
F7	IN-GRADE HIGH OUTPUT LED FLOOD LIGHT, NARROW SPOT DISTRIBUTION, INTERNALLY ADJUSTABLE AIMING, WITH LOCKABILITY PROVIDE WITH DOUBLE LENS AND GLARE SHIELDS, UL WET LOCATION AND EXTERIOR RATED, IP 68, DLC LISTED	HYDREL OR ENGINEER APPROVED EQUAL	M9720C-A-LED-P3-30K-MVOLT-NSP-FLC-XX-GS-XX-DNA	INTEGRAL	LED	3000K	80	UNIVERSAL	50	5,100		GROUND		FOR FLAG POLE UPLIGHTING, AIM IN FIELD WITH ARCHITECT OR LIGHTING DESIGNER.
F8	ROUND LED DOWNLIGHT RETROFIT, WET LOCATION UL WET LOCATION AND EXTERIOR RATED	ACUITY OR ENGINEER APPROVED EQUAL	LRT6 SERIES OR LRT8 SERIES	INTEGRAL	LED	3000K		UNIVERSAL	75			RECESSED CEILING		CONTRACTOR TO CONFIRM SIZE IN FIELD. CONTRACTOR TO VERIFY AND PROVIDE COMPATIBLE RETROFIT KIT.
E	EXISTING FIXTURE LED WALLPACK, DIE-CAST ALUMINUM, GLASS LENS, SURFACE MOUNTED, HIGH-TEMPERATURE SILICONE GASKETS, 70 CRI, 15,000 LUMENS UL WET LOCATION AND EXTERIOR RATED	RAB LIGHTING OR ENGINEER APPROVED EQUAL	EXISTING FIXTURE WP3LED-110W	INTEGRAL	LED	4000K		UNIVERSAL	110			SURFACE WALL		
E2	EXISTING FIXTURE AND POLE 40' COBRA DUAL-HEADED ROADWAY LUMINAIRE, MOUNTED ON CUSTOM POLE UL WET LOCATION AND EXTERIOR RATED	SIGNIFY LUMEC OR ENGINEER APPROVED EQUAL	EXISTING FIXTURE AND POLE ROADFOCUS RFM-160W48LED-4K-G2-R2M-UNV	INTEGRAL	LED ARRAY	3000K		UNIVERSAL	165 EACH HEAD			POLE		
EX1	LED, EDGE-LIT STYLE RED-LETTERS ON WHITE BACKGROUND EXIT SIGN WITH INTEGRAL BATTERY BACKUP AND SELF-TEST/DIAGNOSTIC FEATURES	DUAL-LITE OR ENGINEER APPROVED EQUAL	LES-W-S-R-X-W-E-I-W		LED							SURFACE WALL		
EBU	UNIT BATTERY PACK WITH (2) INTEGRAL ADJUSTABLE OPTICS HEADS, 300 LUMENS EACH, INTEGRAL TEST SWITCH/INDICATOR LAMP, SELF-DIAGNOSTIC TESTING AND MINIMUM 4-HOUR OUTPUT, MUST SUPPORT REMOTE HEAD	SURE-LITES OR ENGINEER APPROVED EQUAL	MAIN UNIT: SELM50R14SD REMOTE HEAD: APWR-2		LED			UNIVERSAL	1.7	300 EACH HEAD		SURFACE WALL		PROVIDE REMOTE HEADS AS INDICATED ON PLANS



- NOTES:
- REFER TO SPECIFICATIONS FOR ADDITIONAL LIGHTING FIXTURE REQUIREMENTS.
 - NOT USED
 - ALL DIMENSIONS LISTED ABOVE ARE NOMINAL SIZES. SLIGHT VARIATIONS IN SHAPE OR SIZE WILL BE CONSIDERED BASED ON THE PROJECT REQUIREMENTS.
 - NOT USED
 - NOT USED
 - MOD USED WITHIN ANY CATALOG NUMBER IDENTIFIES AN OPTION NOT LISTED ON A STANDARD CUTSHEET. REFER TO DEFINITION WITHIN FIXTURE DESCRIPTION AND CATALOG NUMBER COLUMN FOR FIXTURE MODIFICATION REQUIREMENTS.
 - ALL FIXTURES SHALL BE UL LISTED. ALL DAMP AND WET LOCATION UL REQUIREMENTS ARE LISTED IN THE FIXTURE DESCRIPTION.
 - WHERE DIMMING OR INTEGRAL FIXTURE CONTROLS ARE SPECIFIED, COMPATIBILITY OF FIXTURE AND CONTROLS, COMPONANETS SHALL BE VERIFIED BY THE CONTRACTOR PRIOR TO ORDERING OF EITHER SYSTEM.
 - COORDINATE BOLT PATTERNS WITH EXISTING STRUCTURAL TIE-INS. MODIFICATIONS MAY BE REQUIRED.
 - MANUFACTURER SHALL PROVIDE POLE DIAMETER, THICKNESS, HEIGHT AND MIN. YIELD STRENGTH BASED ON POLE HEIGHT, EPA AND WIND LOADS. PROVIDE CALCULATION AND POLE SPECS VIA SHOP DRAWINGS FOR ENGINEER AND LIGHTING DESIGNER REVIEW.

Permits:
A21-1888 - Terminal C Garage C
B22-0021 - Terminal C Garage B
B22-0022 - Terminal C Garage A
B22-0023 - Terminal C Roadway



DALLAS
FORT WORTH
INTERNATIONAL
AIRPORT

2330 N INTERNATIONAL PARKWAY
DFW AIRPORT, TX 75261

Hobas, Clark & Rosenbaum, Inc.
717 North Memorial Drive
Dallas, TX 75201
1-214-728-6000

Primera Engineers, Ltd.
3000 Easton
Suite 214
Coppell, TX 75011
1-972-999-9910

PROJECT NUMBER: TFD007

DRAWN BY: BMAY
APPROVED BY: RL/DS
ISSUE DATE: 2022-07-28

NO.	DATE	DESCRIPTION
2021-10-29	30% DESIGN	
2022-01-06	70% DESIGN	
2022-08-01	100% DESIGN	
2022-07-28	100% ISSUED FOR PERMIT (IFP)	

NOT FOR BID OR CONSTRUCTION

PROJECT NUMBER: TFD-007

TERMINAL C GARAGE AND ROADWAYS
ELECTRICAL SCHEDULES

PERMIT NUMBER: A21-1888

SHEET NUMBER
ES604-900R

LIGHTING CONTACTOR SCHEDULE							
TAG	CONTROLLED CIRCUITS	NUMBER OF POLES	AREA CONTROLLED	CONTROL GROUP	VOLTAGE	CIRCUITS ARE FED FROM	REMARKS
LC-01	14,16,18,20	8	ELEVATED ROAD - GARAGE A	R-E	277V	A-1BH1	
LC-02	10,12	8	ELEVATED ROAD - GARAGE B	R-E	277V	B-1BH1	
LC-03	18,20	8	ELEVATED ROAD - GARAGE C	R-E	277V	C-1BH1	
LC-04	26,28,30,32	4	LOWER ROADWAY - A	R-U	277V	A-1BH1	
LC-05	14,16,18,20	4	LOWER ROADWAY - B	R-U	277V	B-1BH1	
LC-06	26,28,30,32	4	LOWER ROADWAY - C	R-U	277V	C-1BH1	
LC-07	1,2	4	EM LIGHTING - A	R-U	277V	INVAB	
LC-08	1,2	4	EM LIGHTING - B	R-U	277V	INVBB	
LC-09	1,2	4	EM LIGHTING - C	R-U	277V	INVCC	
LC-10	40,42	10	CAROUSEL ROADWAY - A	R-C	277V	A-1BH1	
LC-11	6,8	4	CAROUSEL ROADWAY - B	R-C	277V	B-1BH1	
LC-12	14,16	4	CAROUSEL ROADWAY - C	R-C	277V	C-1BH1	
LC-13	2	2	FLAG LIGHTS	F	277V	B-1BH1	
LC-14	38	2	ROAD SIGNAGE - A	R-S	277V	A-1BH1	
LC-15	30,32	2	ROAD SIGNAGE - B	R-S	277V	B-1BH1	
LC-16	38	2	ROAD SIGNAGE - C	R-S	277V	C-1BH1	

*LETTERS CORRESPOND TO DIFFERENT CONTROL GROUPS**, DESIGNATED AS FOLLOWS:

R-E ROADWAY - ELEVATED
R-U ROADWAY - UNDERPASS
R-C ROADWAY - CAROUSEL
F FLAG POLES
R-S ROADWAY - SIGNAGE

**GROUPS SUBJECT TO CHANGE PER OWNER'S REQUIREMENTS

LIGHTING CONTROLS SUMMARY													
AREA	ZONE NAME	FUNCTION DESCRIPTION	DIMMING INTEGRAL TO FIXTURE	PHOTO CELL	DIMMING AS PART OF CONTROL SYSTEM	LOCAL MANUAL SWITCHING	MASTER SWITCH	MASTER SWITCH OVERRIDE	TIME SWEEP ON/OFF		YES-NO	GROUP TAG	
									YES	NO			
ELEVATED ROADWAY													
GARAGE A	ELEVATED ROADWAY - A	ORIENTATION / SECURITY		X			HOA				YES	R-E	
GARAGE B	ELEVATED ROADWAY - B	ORIENTATION / SECURITY		X			HOA				YES	R-E	
GARAGE C	ELEVATED ROADWAY - C	ORIENTATION / SECURITY		X			HOA				YES	R-E	
GARAGE A	INTERCONNECTING RAMP - A	ORIENTATION / SECURITY		X			HOA				YES	R-E	
GARAGE B	INTERCONNECTING RAMP - B	ORIENTATION / SECURITY		X			HOA				YES	R-E	
GARAGE C	INTERCONNECTING RAMP - C	ORIENTATION / SECURITY		X			HOA				YES	R-E	
LOWER ROADWAY													
GARAGE A	LOWER ROADWAY - A	ORIENTATION / SECURITY		X			HOA				YES	R-U	
GARAGE B	LOWER ROADWAY - B	ORIENTATION / SECURITY		X			HOA				YES	R-U	
GARAGE C	LOWER ROADWAY - C	ORIENTATION / SECURITY		X			HOA				YES	R-U	
GARAGE A	LOWER ROADWAY EM - A	EGRESS					HOA				NO	R-U	
GARAGE B	LOWER ROADWAY EM - B	EGRESS					HOA				NO	R-U	
GARAGE C	LOWER ROADWAY EM - C	EGRESS					HOA				NO	R-U	
CAROUSEL ROADWAY													
GARAGE A	CAROUSEL ROADWAY - A	ORIENTATION / SECURITY		X			HOA				YES	R-C	
GARAGE B	CAROUSEL ROADWAY - B	ORIENTATION / SECURITY		X			HOA				YES	R-C	
GARAGE C	CAROUSEL ROADWAY - C	ORIENTATION / SECURITY		X			HOA				YES	R-C	
GARAGE B	FLAG LIGHTS	DECORATIVE		X			HOA				YES	F	
GARAGE A	OVERPASS DOWNLIGHTS	ORIENTATION / SECURITY		X			HOA				YES	R-C	
GARAGE A	ROAD SIGNAGE - A	ORIENTATION		X			HOA				YES	R-S	
GARAGE B	ROAD SIGNAGE - B	ORIENTATION		X			HOA				YES	R-S	
GARAGE C	ROAD SIGNAGE - C	ORIENTATION		X			HOA				YES	R-S	

NOTES:

- LOCAL HOA SWITCHES SHALL CONTROL ALL CIRCUITS AS INDICATED BY THIS SCHEDULE AND CIRCUITING SHOWN ON PLANS.
- THERE SHALL BE A REGULAR-USE TIME OF DAY SCHEDULE. TIMER = TIME CLOCK.
- SECURITY EXTERIOR LIGHTING SHALL BE ON AT FULL THROUGHOUT THE NIGHT. DECORATIVE EXTERIOR LIGHTING SHALL TURN OFF FROM MIDNIGHT TO 6AM. AT 6AM, THEY RETURN TO FULL BRIGHTNESS.
- ALL CONTROLS SETTINGS AND SCENES SHALL BE REVIEWED WITH THE LIGHTING DESIGNER AND OWNER WITH THE PROGRAMMER IN THE FIELD. ALTERATIONS MAY BE MADE AT THAT TIME.
- THERE SHALL BE A PRE-PROGRAMMING MEETING TO REVIEW INTENT AND REQUIREMENTS PRIOR TO ANY ON-SITE PROGRAMMING BEING DONE. THERE SHALL BE A POST-PROGRAMMING MEETING IN THE FIELD TO CONFIRM SCENES AND SETTINGS WITH BOTH THE LIGHTING DESIGNER AND OWNER. CONTRACTOR IS RESPONSIBLE FOR COORDINATING BOTH MEETINGS.

OS # = OCCUPANCY SENSOR
PC = PHOTOCELL
OC SWITCH = OCCUPANCY SENSOR WITH MANUAL SWITCH OVERRIDE
TIMER = TIME CLOCK
DC = DC DIMMING
ML = MULTI-LEVEL SWITCHING
SL = SINGLE-LEVEL SWITCHING
PSC = PRE-SET SCENE CONTROLLER
SLDO = SINGLE-LEVEL SWITCHING WITH DIMMING
MLDO = MULTI-LEVEL SWITCHING WITH DIMMING
MLTO = MULTI-LEVEL SWITCHING WITH LOCAL OVERRIDE OF TIME-SWEEP
SLK = SINGLE LEVEL KEYED SWITCH
SL-O = SINGLE LEVEL OVERRIDE SWITCH
HOA = HAND-OFF/AUTO SWITCH

OS # = OVERRIDE SWITCH NAME
MS # = MASTER SWITCH NAME

TAG: PP-1A													
MTG: SURFACE													
RM: SWITCH ROOM 130													
VOLTAGE: 480/277 Wye-3													
BUS: 225 A													
GROUND: 100%													
NEUTRAL: 100%													
REMARKS: 225 A MCB													
REMARKS: 65KAIC													
CKT	DESCRIPTION	TYPE	P	VA	A	B	C	VA	P	TYPE	DESCRIPTION	CKT	
1		L		3820	0			20 A	1	--	SPARE	2	
3	TR-1A	SP	3	50 A		6160	0	20 A	1	--	SPARE	4	
5		R					2960	0	20 A	1	SPARE	6	
7	PROVISION	--	1	--	--	--	--	--	1	--	PROVISION	8	
9	PROVISION	--	1	--	--	--	--	--	1	--	PROVISION	10	
11	PROVISION	--	1	--	--	--	--	--	1	--	PROVISION	12	
13	PROVISION	--	1	--	--	--	--	--	1	--	PROVISION	14	
15	PROVISION	--	1	--	--	--	--	--	1	--	PROVISION	16	
17	PROVISION	--	1	--	--	--	--	--	1	--	PROVISION	18	
19	PROVISION	--	1	--	--	--	--	--	1	--	PROVISION	20	
21	PROVISION	--	1	--	--	--	--	--	1	--	PROVISION	22	
23	PROVISION	--	1	--	--	--	--	--	1	--	PROVISION	24	
TOTAL VA PHASE A				3820 VA	TOTAL CONNECTED AMPS				16 A				
TOTAL VA PHASE B				6160 VA	TOTAL CONNECTED VA				12960 VA				
TOTAL VA PHASE C				2960 VA	TOTAL DESIGN AMPS				16 A				

TAG: PP-1C													
MTG: SURFACE													
RM: SWITCH ROOM 131													
VOLTAGE: 480/277 Wye-3													
BUS: 225 A													
GROUND: 100%													
NEUTRAL: 100%													
REMARKS: 225 A MCB													
REMARKS: 65KAIC													
CKT	DESCRIPTION	TYPE	P	VA	A	B	C	VA	P	TYPE	DESCRIPTION	CKT	
1		L		3940	0			20 A	1	--	SPARE	2	
3	TR-1C	SP	3	50 A		5830	0	20 A	1	--	SPARE	4	
5		R					3080	0	20 A	1	SPARE	6	
7	PROVISION	--	1	--	--	--	--	--	1	--	PROVISION	8	
9	PROVISION	--	1	--	--	--	--	--	1	--	PROVISION	10	
11	PROVISION	--	1	--	--	--	--	--	1	--	PROVISION	12	
13	PROVISION	--	1	--	--	--	--	--	1	--	PROVISION	14	
15	PROVISION	--	1	--	--	--	--	--	1	--	PROVISION	16	
17	PROVISION	--	1	--	--	--	--	--	1	--	PROVISION	18	
19	PROVISION	--	1	--	--	--	--	--	1	--	PROVISION	20	
21	PROVISION	--	1	--	--	--	--	--	1	--	PROVISION	22	
23	PROVISION	--	1	--	--	--	--	--	1	--	PROVISION	24	
TOTAL VA PHASE A				3940 VA	TOTAL CONNECTED AMPS				15 A				
TOTAL VA PHASE B				5830 VA	TOTAL CONNECTED VA				12850 VA				
TOTAL VA PHASE C				3080 VA	TOTAL DESIGN AMPS				16 A				

TAG: LP-1A													
MTG: SURFACE													
RM: SWITCH ROOM 130													
VOLTAGE: 120/208 Wye-3													
BUS: 100 A													
GROUND: 100%													
NEUTRAL: 100%													
REMARKS: 100 A MCB													
REMARKS: 10KAIC													
CKT	DESCRIPTION	TYPE	P	VA	A	B	C	VA	P	TYPE	DESCRIPTION	CKT	
1	LIGHTING	L	1	20 A	560	0		20 A	1	--	SPARE	2	
3	REC	R	1	20 A		180	2400	25 A	2	H	OUI/U-4	4	
5	REC	R	1	20 A		180	2400	25 A	2	H	OUI/U-2	6	
7	REC	R	1	20 A	360	2400		25 A	2	H	OUI/U-3	8	
9	EXTERIOR REC	R	1	20 A		180	2400	25 A	2	H	OUI/U-1	10	
11	EXTERIOR REC	R	1	20 A			180	0	20 A	1	SPARE	12	
13	***FCP	E	1	20 A	500	0		20 A	1	--	SPARE	14	
15	***DATA RACK	R	1	20 A		1000	0	20 A	1	--	SPARE	16	
17	EXTERIOR LTG	L	1	20 A			220	0	20 A	1	SPARE	18	
19	SPARE	--	1	20 A	0	0		20 A	1	--	SPARE	20	
21	SPARE	--	1	20 A		0	0	20 A	1	--	SPARE	22	
23	SPARE	--	1	20 A			0	0	20 A	1	SPARE	24	
25	SPARE	--	1	20 A	0	0		20 A	1	--	SPARE	26	
27	SPARE	--	1	20 A		0	0	20 A	1	--	SPARE	28	
29	SPARE	--	1	20 A			0	0	20 A	1	SPARE	30	
31	PROVISION	--	1	--	--	--	--	--	1	--	PROVISION	32	
33	PROVISION	--	1	--	--	--	--	--	1	--	PROVISION	34	
35	PROVISION	--	1	--	--	--	--	--	1	--	PROVISION	36	
37	PROVISION	--	1	--	--	--	--	--	1	--	PROVISION	38	
39	PROVISION	--	1	--	--	--	--	--	1	--	PROVISION	40	
41	PROVISION	--	1	--	--	--	--	--	1	--	PROVISION	42	
TOTAL VA PHASE A				3820 VA	TOTAL CONNECTED AMPS				36 A				
TOTAL VA PHASE B				6160 VA	TOTAL CONNECTED VA				12960 VA				
TOTAL VA PHASE C				2960 VA	TOTAL DESIGN AMPS				37 A				

***PROVIDE CIRCUIT BREAKER WITH RED HANDLE, LOCKED IN "ON" POSITION

TAG: LP-1C													
MTG: SURFACE													
RM: SWITCH ROOM 131													
VOLTAGE: 120/208 Wye-3													
BUS: 100 A													
GROUND: 100%													
NEUTRAL: 100%													
REMARKS: 100 A MCB													
REMARKS: 10KAIC													
CKT	DESCRIPTION	TYPE	P	VA	A	B	C	VA	P	TYPE	DESCRIPTION	CKT	
1	REC	R	1	20 A	360	0		20 A	1	--	SPARE	2	
3	REC	R	1	20 A		360	2400	25 A	2	H	OUI/U-2	4	
5	EXTERIOR REC	R	1	20 A		180	2400	25 A	2	H	OUI/U-1	6	
7	EXTERIOR REC	R	1	20 A	180	2400		25 A	2	H	OUI/U-1	8	
9	LIGHTING	L	1	20 A		450	2400	25 A	2	H	OUI/U-1	10	
11	***FCP	E	1	20 A			500	0	20 A	1	SPARE	12	
13	***DATA RACK	R	1	20 A	1000	0		20 A	1	--	SPARE	14	
15	EXTERIOR LTG	L	1	20 A		220	0	20 A	1	--	SPARE	16	
17	SPARE	--	1	20 A			0	0	20 A	1	SPARE	18	
19	SPARE	--	1	20 A	0	0		20 A	1	--	SPARE	20	
21	SPARE	--	1	20 A		0	0	20 A	1	--	SPARE	22	
23	SPARE	--	1	20 A			0	0	20 A	1	SPARE	24	
25	SPARE	--	1	20 A	0	0		20 A	1	--	SPARE	26	
27	SPARE	--	1	20 A		0	0	20 A	1	--			

PLANT SCHEDULE						
XERISCAPE	CODE	BOTANICAL NAME	COMMON NAME	SIZE	SPACING	QTY
	CF	CYRTOMIUM FALCATUM	HOLLY FERN	1 GAL.	18" o.c.	347
	HB	HESPERALOE PARVIFLORA 'PERPA' TM	BRAKELIGHTS RED YUCCA	1 GAL.	36" o.c.	129
	JH	JUNIPERUS HORIZONTALIS	CREEPING JUNIPER	1 GAL.	18" o.c.	71
	LM	LIRIOPE MUSCARI	LILYTURF	1 GAL.	18" o.c.	1,104
	MC	MUHLENBERGIA CAPILLARIS	PINK MUHLY GRASS	1 GAL.	24" o.c.	115
	PA	PENNISETUM ALOPECUROIDES	FOUNTAIN GRASS	1 GAL.	24" o.c.	189
	RB	RUDBECKIA FULGIDA	CONEFLOWER	1 GAL.	18" o.c.	527

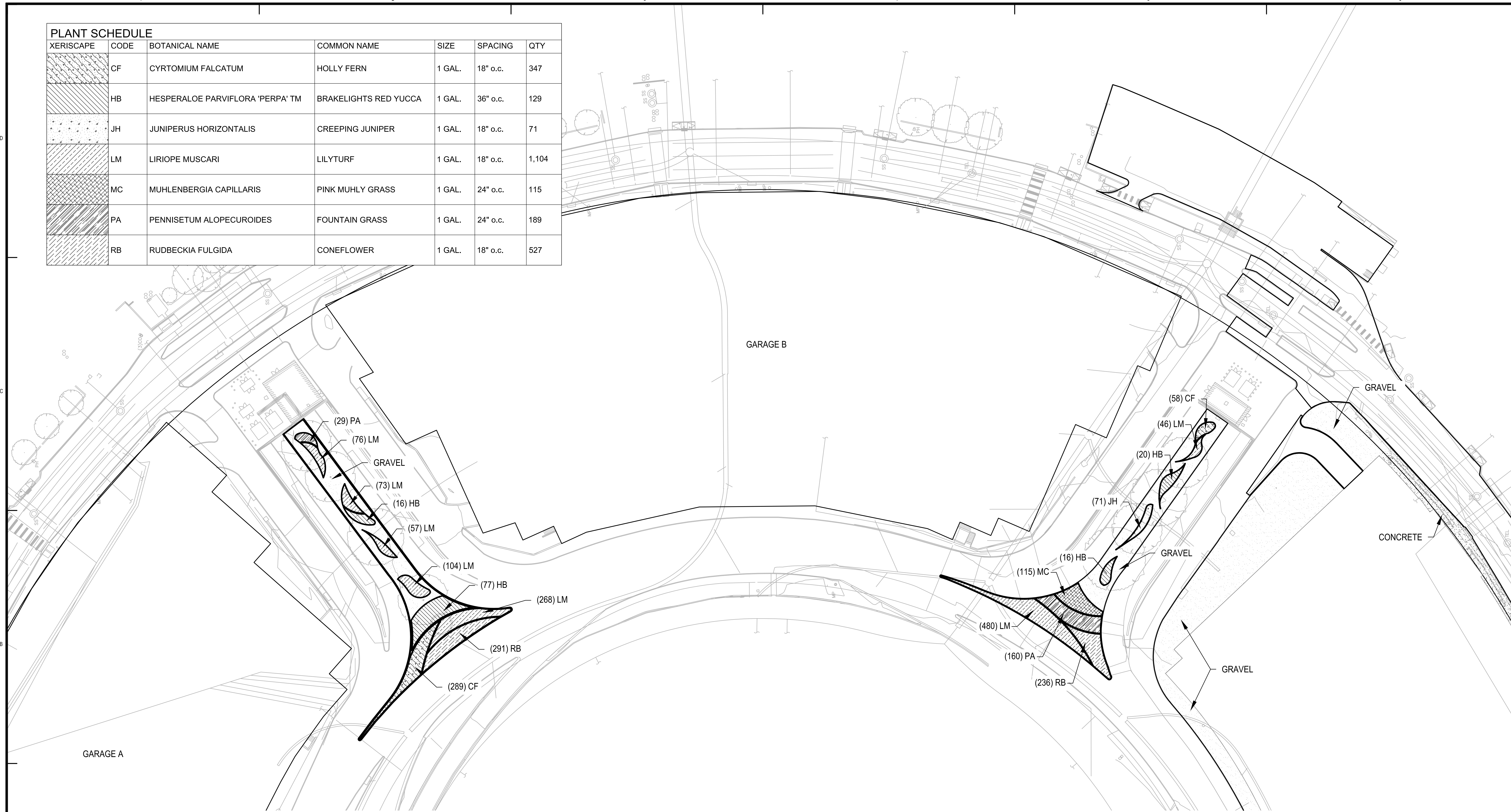

1" = 30'-0"

GENERAL NOTES

KEY NOTES

KEY PLAN

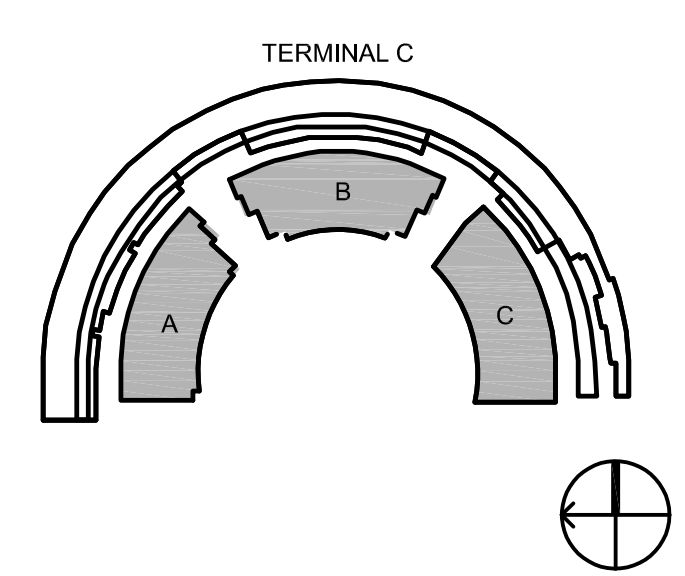

2330 N INTERNATIONAL PARKWAY
DFW AIRPORT, TX 75261



McGraw Hill Construction, Inc.
717 South Main Street
Dallas, TX 75201
+1 214 724 8000

DRAWN BY: CS
APPROVED BY: ZC
ISSUE DATE: 2022-07-28

**NOT FOR BID OR
CONSTRUCTION**

NO.	DATE	DESCRIPTION
0001-01-20	2022-01-20	30% DESIGN
0002-01-20	2022-01-20	30% DESIGN
0003-01-20	2022-01-20	100% DESIGN
0004-01-20	2022-01-20	100% DESIGN FOR PERMIT (DPP)

DFW TERMINAL C GARAGE AND ROADWAYS
LANDSCAPE PLAN AREA A

PROJECT NUMBER: TFD-007

PERMIT NUMBER: B22-0023

SHEET NUMBER
L101-900R

SCALE(S) AS NOTED ON THIS SHEET ARE BASED ON A FULL SIZE 30 X 42 SHEET.

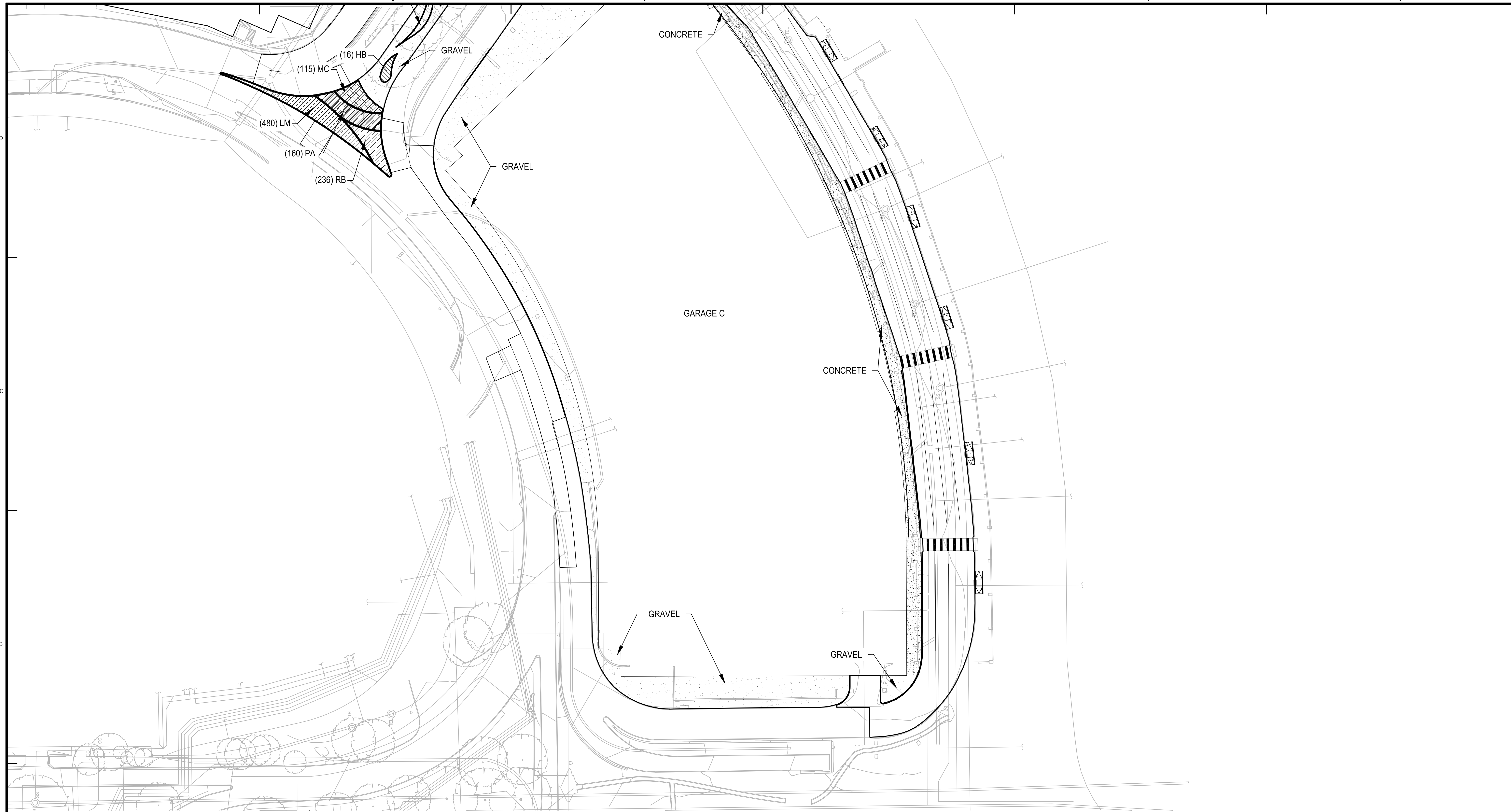

GENERAL NOTES

KEY NOTES

KEY PLAN

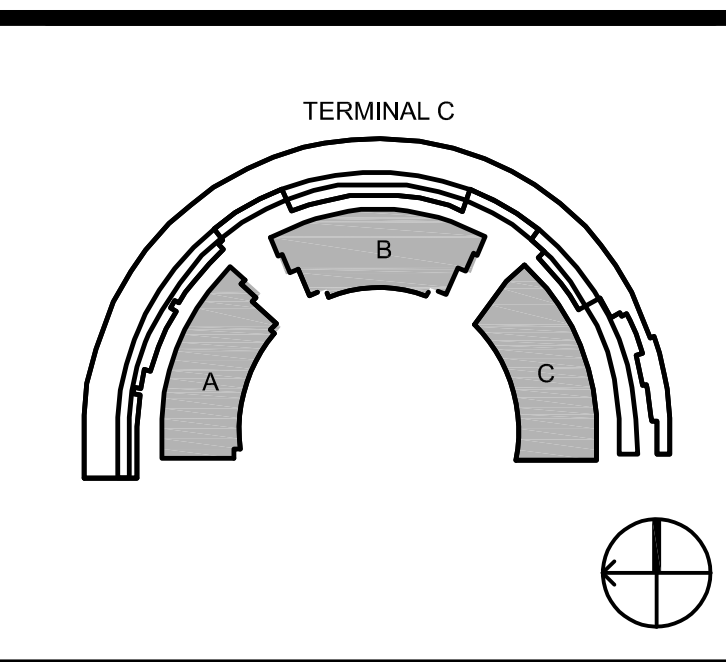

DFW DALLAS FORT WORTH INTERNATIONAL AIRPORT

2330 N INTERNATIONAL PARKWAY
DFW AIRPORT, TX 75261

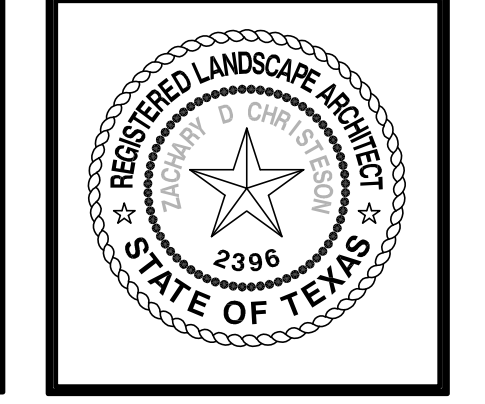

McMurry, Clark & Koenigstein, Inc.
777 North Meadows Drive
Dallas, TX 75201
+1 214 751 8000

DRAWN BY: CS
APPROVED BY: ZC
ISSUE DATE: 2022-07-28

NOT FOR BID OR CONSTRUCTION

NO.	DATE	DESCRIPTION
0001	07-28-22	30% DESIGN
0002	01-06-23	30% DESIGN
0003	01-06-23	100% DESIGN
0004	02-28-23	100% DESIGN FOR PERMIT (DPP)

DFW TERMINAL C GARAGE AND ROADWAYS
LANDSCAPE PLAN AREA B

PROJECT NUMBER: TFD-007

PERMIT NUMBER: B22-0023

SHEET NUMBER
L102-900R

SCALE(S) AS NOTED ON THIS SHEET ARE BASED ON A FULL SIZE 30 X 42 SHEET.

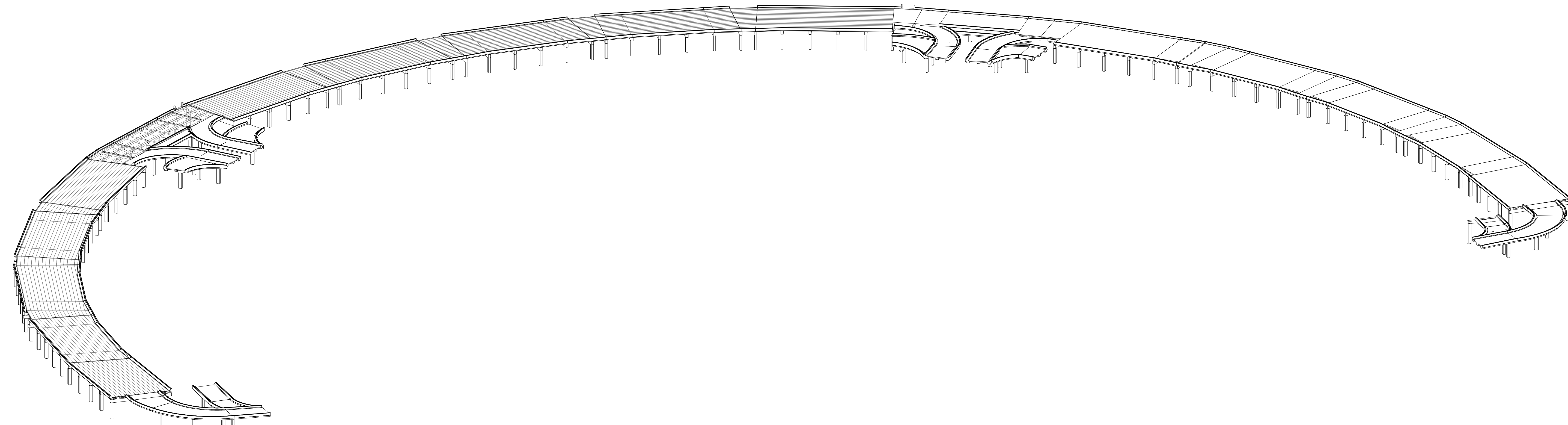

1 ROADWAY OVERALL 3D VIEW

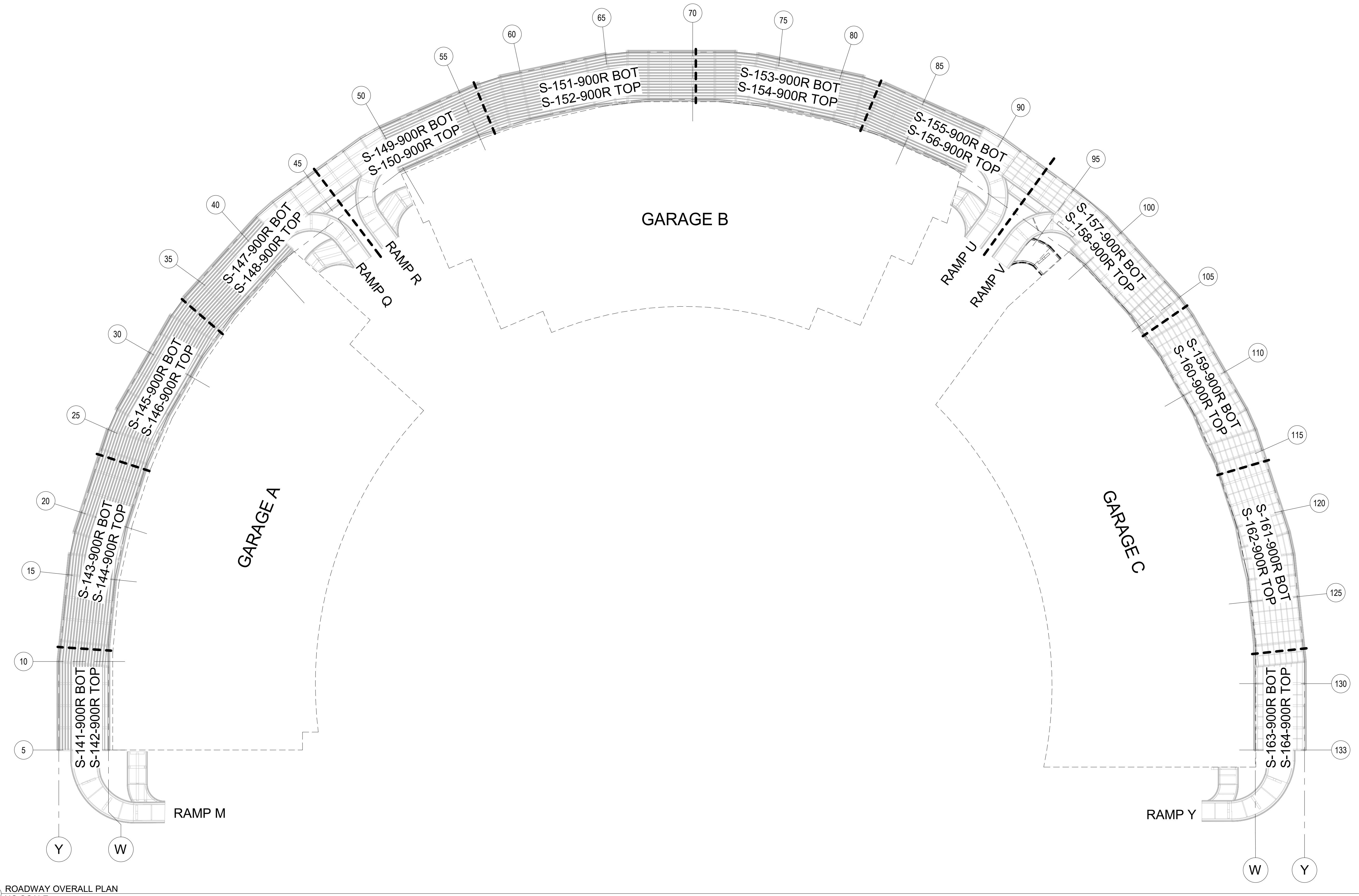

2 ROADWAY OVERALL PLAN
NO SCALE

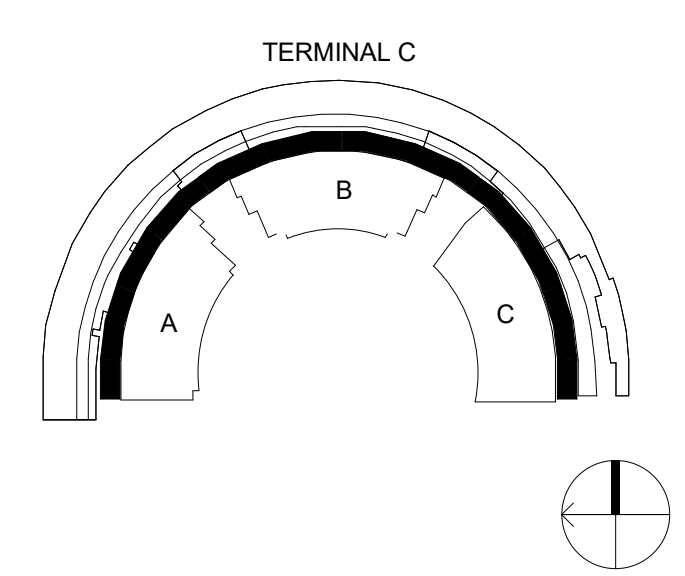

DFW
DALLAS
FORT WORTH
INTERNATIONAL
AIRPORT

2330 N INTERNATIONAL PARKWAY
DFW AIRPORT, TX 75261

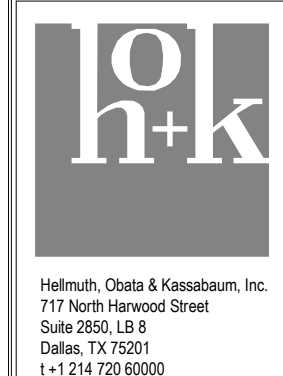
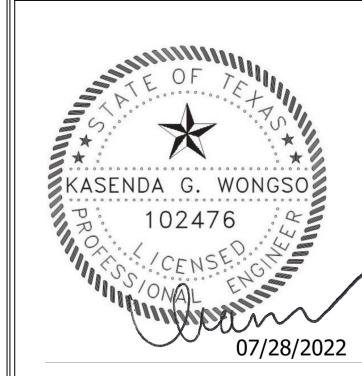

DRAWN BY: ADD/GY
APPROVED BY: KW
ISSUE DATE: 2022-07-28

**NOT FOR BID OR
CONSTRUCTION**

NO.	DATE	DESCRIPTION
2022-01-09	75% DESIGN	
2022-03-01	100% DESIGN	
2022-07-28	100% ISSUED FOR PERMIT (IFP)	

DFW TERMINAL C GARAGE AND ROADWAY
ROADWAY OVERALL 3D VIEW & PLAN

PROJECT NUMBER: TFD-007

PERMIT NUMBER: B22-0023

SHEET NUMBER
S-140-900R

SCALE(S) AS NOTED ON THIS SHEET ARE BASED ON A FULL SIZE 30 X 42 SHEET.

OBSERVATION NOTE	OBSERVED CONDITION	REPAIR NOTE
RM-B-01	GIRDER CRACKS	REPAIR CRACKS PER GENERAL NOTES
RM-B-02	GIRDER EFFLORESCENCE	CLEAN CONCRETE SURFACE
RM-B-03	GIRDER SPALL	REPAIR SPALLS PER GENERAL NOTES
RM-B-04	DECK CRACKS	REPAIR CRACKS PER GENERAL NOTES
RM-B-05	DECK EFFLORESCENCE	CLEAN CONCRETE SURFACE
RM-B-06	RAILING PARAPET WALL CRACKS	REPAIR CRACKS PER GENERAL NOTES
RM-B-07	RAILING PARAPET WALL SPALL	REPAIR SPALLS PER GENERAL NOTES
RM-B-08	RAILING PARAPET WALL EXPOSED REBARS	REPAIR SPALLS PER GENERAL NOTES
RM-B-09	OVERHANG CRACKS	REPAIR CRACKS PER GENERAL NOTES
RM-B-10	COLUMN CRACKS	REPAIR CRACKS PER GENERAL NOTES
RM-B-11	COLUMN SPALL	REPAIR SPALLS PER GENERAL NOTES
RA-B-01	GIRDER CRACKS	REPAIR CRACKS PER GENERAL NOTES
RA-B-02	GIRDER EFFLORESCENCE	CLEAN CONCRETE SURFACE
RA-B-03	GIRDER SPALL	REPAIR SPALLS PER GENERAL NOTES
RA-B-04	GIRDER EXPOSED REBARS	REPAIR SPALLS PER GENERAL NOTES
RA-B-05	SPANDREL BEAM CRACKS	REPAIR CRACKS PER GENERAL NOTES
RA-B-06	SPANDREL BEAM SPALL	REPAIR SPALLS PER GENERAL NOTES
RA-B-07	COLUMN CRACKS	REPAIR CRACKS PER GENERAL NOTES
RA-B-08	COLUMN SPALL	REPAIR SPALLS PER GENERAL NOTES
RA-B-09	COLUMN EXPOSED REBARS	REPAIR SPALLS PER GENERAL NOTES
RA-B-10	DOUBLE-TEE STEM SPALLS	REPAIR SPALLS PER GENERAL NOTES
RA-B-11	ANCHOR BOLTS AND ANGLE CORROSION	BEAD BLAST STEEL AND TOUCH UP WITH TMEC ZINC RICH PAINT
RA-B-12	OVERHANG SPALL	REPAIR SPALLS PER GENERAL NOTES
RA-B-13	OVERHANG CRACKS	REPAIR CRACKS PER GENERAL NOTES

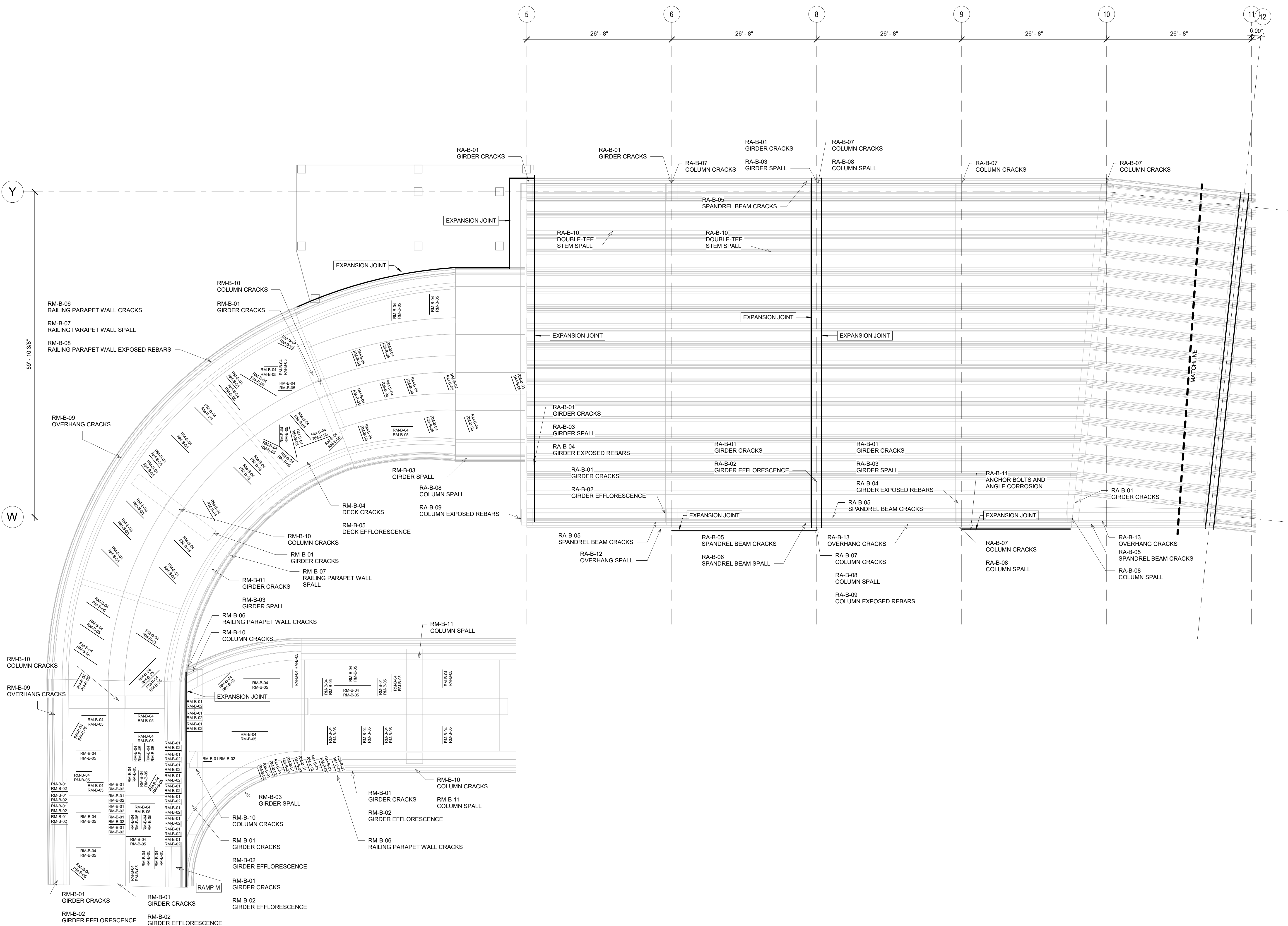

1 FRAMING PLAN - GRIDS 5-12 & RAMP M (BOTTOM)
1/8" = 1'-0"

OBSERVATION NOTE KEY	
01-99:	OBSERVATION NUMBER
B:	OBSERVATION FROM BOTTOM
T:	OBSERVATION FROM TOP
M:	ROADWAY AT RAMP M
A:	ROADWAY IN FRONT OF GARAGE A
Q:	ROADWAY AT RAMP Q & R
B:	ROADWAY IN FRONT OF GARAGE B
U:	ROADWAY AT RAMP U & V
C:	ROADWAY IN FRONT OF GARAGE C
Y:	ROADWAY AT RAMP Y

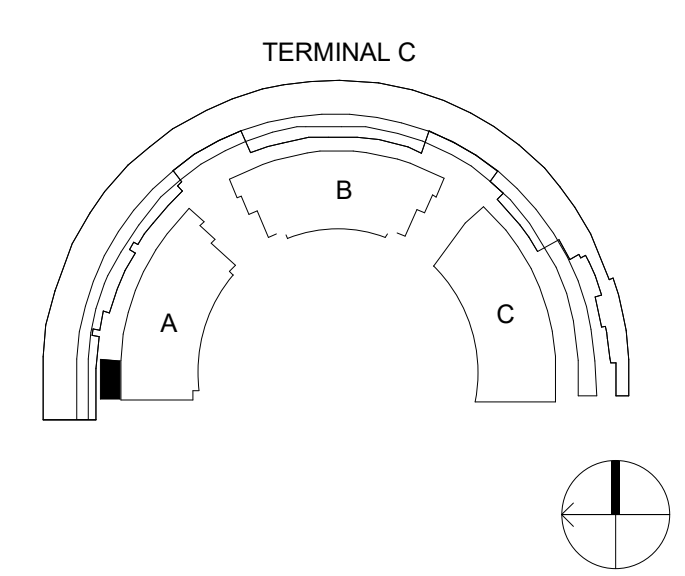

DFW DALLAS FORT WORTH INTERNATIONAL AIRPORT
2330 N INTERNATIONAL PARKWAY
DFW AIRPORT, TX 75261



PROJECT # 21084.00000
15200 Addison Road, Suite 310
Addison, Texas 75001
Ph: 214-562-7802
www.agenie.com
TX REG. NO. F-8429
Structural Integrity

DRAWN BY: ADD/GY
APPROVED BY: KW
ISSUE DATE: 2022-07-28

NOT FOR BID OR CONSTRUCTION

NO.	DATE	DESCRIPTION
2021-10-23	30% DESIGN	
2022-01-09	70% DESIGN	
2022-03-01	100% DESIGN	
2022-07-28	100% ISSUED FOR PERMIT (IFP)	

DFW TERMINAL C GARAGE AND ROADWAY
ROADWAY FRAMING PLAN - GRIDS 5-12 & RAMP M (BOTTOM)
PROJECT NUMBER: TFD-007
PERMIT NUMBER: B22-00023

SHEET NUMBER
S-141-900R

SCALE(S) AS NOTED ON THIS SHEET ARE BASED ON A FULL SIZE 30 X 42 SHEET.

OBSERVATION NOTE	OBSERVED CONDITION	REPAIR NOTE
TYP	CONTRACTOR TO NOTIFY EOR AFTER THE PAVEMENT IS MILLED OFF FOR TOP SLAB SURFACE OBSERVATION	
RM-T-01	DECK CRACKS	REPAIR CRACKS PER GENERAL NOTES
RM-T-02	PAVEMENT WEAR	AFTER SURFACE MILLED OFF, REPAIR CRACKS PER GENERAL NOTES AND RESURFACE PAVEMENT
RM-T-03	JOINT SEAL FAILURE	REPLACE JOINT SEAL ON ROADWAY AND WALKWAY PER GENERAL NOTES
RM-T-04	RAILING PARAPET WALL CRACKS	REPAIR CRACKS PER GENERAL NOTES
RM-T-05	RAILING PARAPET WALL SPALL	REPAIR SPALLS PER GENERAL NOTES
RM-T-06	RAILING PARAPET WALL EXPOSED REBARS	REPAIR SPALLS PER GENERAL NOTES
RA-T-01	PAVEMENT CRACKS	AFTER SURFACE MILLED OFF, REPAIR CRACKS PER GENERAL NOTE...
RA-T-02	PAVEMENT WEAR	AFTER SURFACE MILLED OFF, REPAIR CRACKS PER GENERAL NOTES AND RESURFACE PAVEMENT
RA-T-03	JOINT SEAL FAILURE	REPLACE JOINT SEAL ON ROADWAY AND WALKWAY PER GENERAL NOTES
RA-T-04	CURB SPALL	REPAIR SPALLS PER GENERAL NOTES

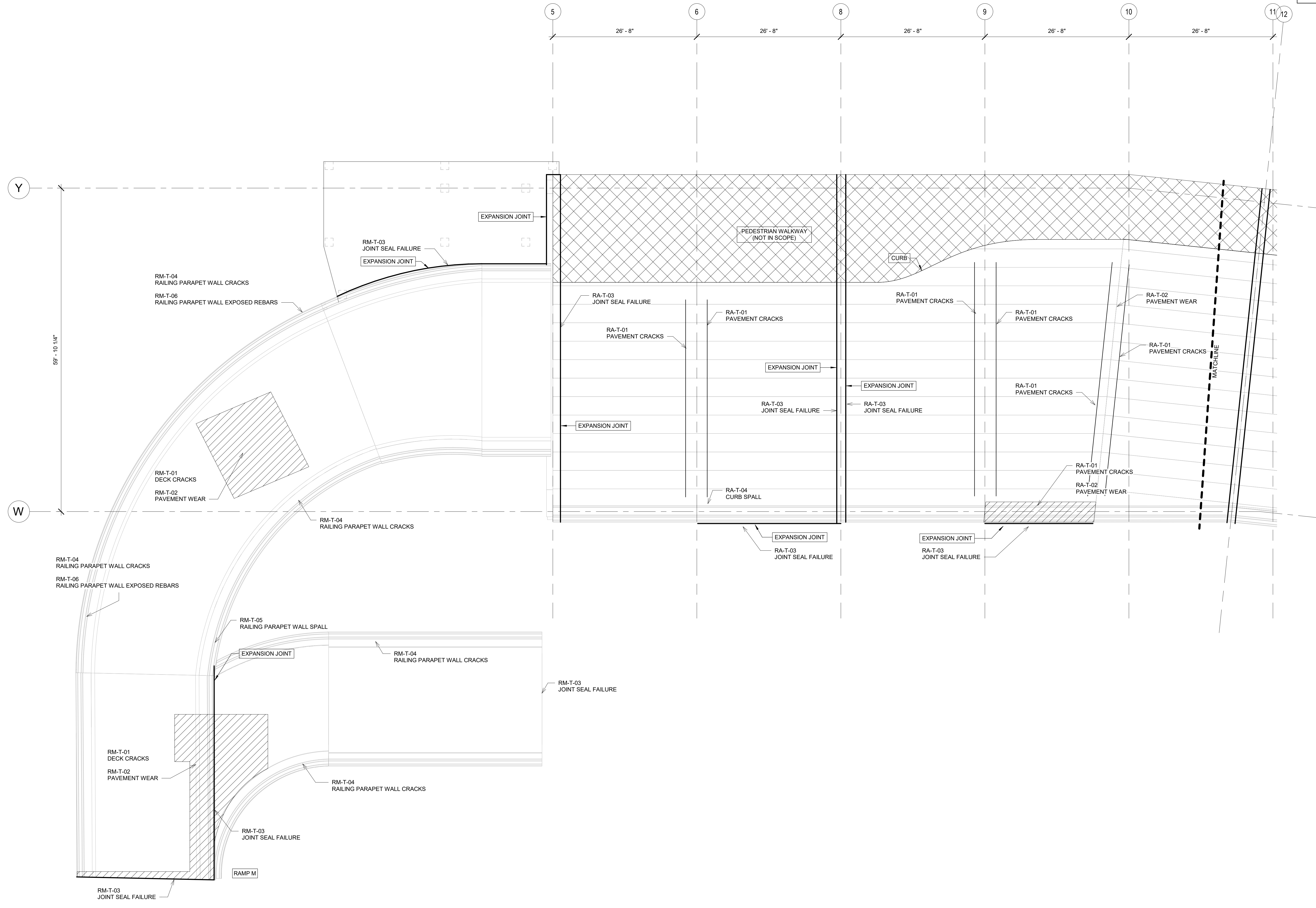

1 FRAMING PLAN - GRIDS 5-12 & RAMP M (TOP)
1/8" = 1'-0"

OBSERVATION NOTE KEY	
01-99	OBSERVATION NUMBER
B	OBSERVATION FROM BOTTOM
T	OBSERVATION FROM TOP
M	ROADWAY AT RAMP M
A	ROADWAY IN FRONT OF GARAGE A
Q	ROADWAY AT RAMP Q & R
B	ROADWAY IN FRONT OF GARAGE B
U	ROADWAY AT RAMP U & V
C	ROADWAY IN FRONT OF GARAGE C
Y	ROADWAY AT RAMP Y

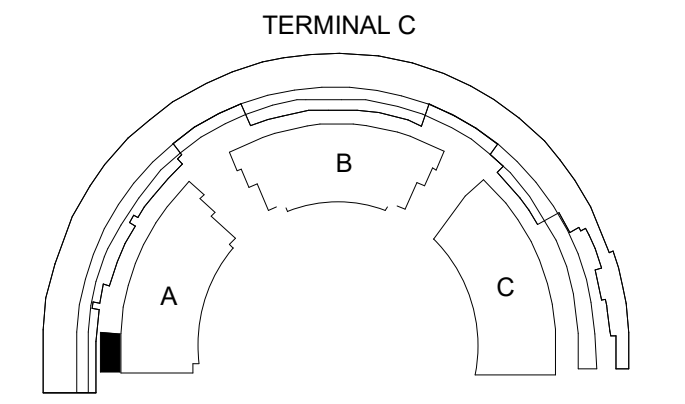

2330 N INTERNATIONAL PARKWAY
DFW AIRPORT, TX 75261

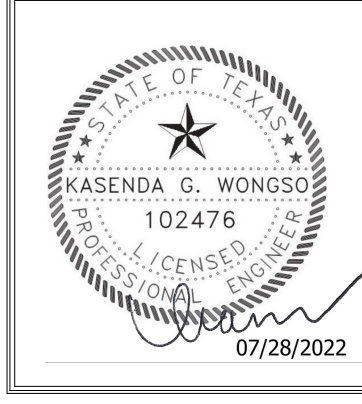

PROJECT # 21084.00000
15200 Addison Road, Suite 310
Addison, Texas 75001
Ph: 214.503.7602
www.ageno.com
TX REG. NO. F-8439
1+214.722.6000

DRAWN BY: ADD/GY
APPROVED BY: KW
ISSUE DATE: 2022-07-28

NOT FOR BID OR CONSTRUCTION

NO.	DATE	DESCRIPTION
2022-01-09	75% DESIGN	
2022-03-01	100% DESIGN	
2022-07-28	100% ISSUED FOR PERMIT (IFP)	

DFW TERMINAL C GARAGE AND ROADWAY
ROADWAY FRAMING PLAN - GRIDS 5-12 & RAMP M (TOP)

PROJECT NUMBER: TFD-007

PERMIT NUMBER: B22-0023

SHEET NUMBER
S-142-900R

SCALE(S) AS NOTED ON THIS SHEET ARE BASED ON A FULL SIZE 30 X 42 SHEET.

OBSERVATION NOTE	OBSERVED CONDITION	REPAIR NOTE
RA-B-26	GIRDER CRACKS	REPAIR CRACKS PER GENERAL NOTES
RA-B-27	GIRDER SPALL	REPAIR SPALLS PER GENERAL NOTES
RA-B-28	GIRDER EXPOSED REBARS	REPAIR SPALLS PER GENERAL NOTES
RA-B-29	GIRDER EFFLORESCENCE	CLEAN CONCRETE SURFACE
RA-B-30	SPANDREL BEAM CRACKS	REPAIR CRACKS PER GENERAL NOTES
RA-B-31	SPANDREL BEAM SPALL	REPAIR SPALLS PER GENERAL NOTES
RA-B-32	COLUMN CRACKS	REPAIR CRACKS PER GENERAL NOTES
RA-B-33	COLUMN SPALL	REPAIR SPALLS PER GENERAL NOTES
RA-B-34	COLUMN EXPOSED REBARS	REPAIR SPALLS PER GENERAL NOTES
RA-B-35	COLUMN EFFLORESCENCE	CLEAN CONCRETE SURFACE
RA-B-36	COLUMN CAP CRACKS	REPAIR CRACKS PER GENERAL NOTES
RA-B-37	COLUMN CAP SPALL	REPAIR SPALLS PER GENERAL NOTES
RA-B-38	OVERHANG CRACKS	REPAIR CRACKS PER GENERAL NOTES
RA-B-39	ANCHOR BOLTS AND ANGLE CORROSION	BEAD BLAST STEEL AND TOUCH UP WITH TMEC ZINC RICH PAINT

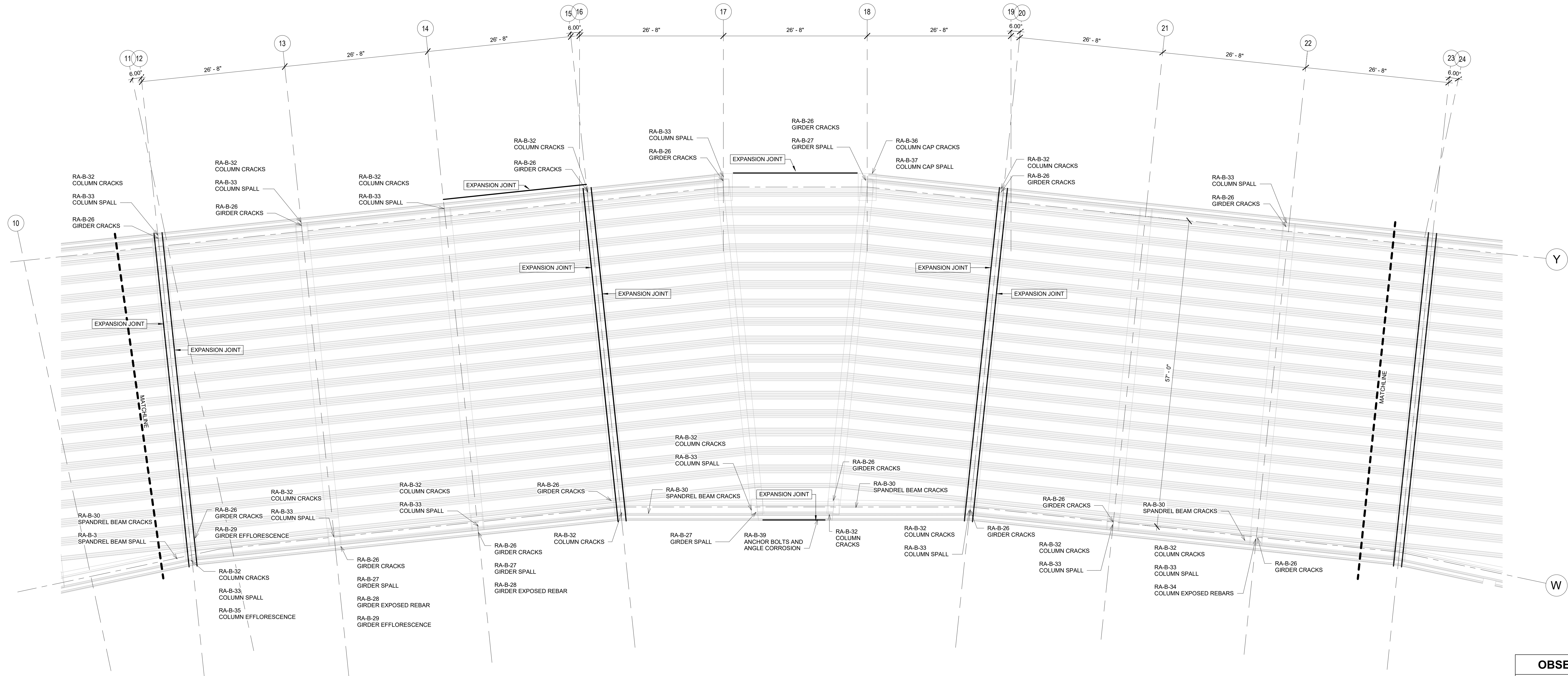

OBSERVATION NOTE KEY

RX-Y-ZZ
 01-99: OBSERVATION NUMBER
 B: OBSERVATION FROM BOTTOM
 T: OBSERVATION FROM TOP

M: ROADWAY AT RAMP M
 A: ROADWAY IN FRONT OF GARAGE A
 Q: ROADWAY AT RAMP Q & R
 B: ROADWAY IN FRONT OF GARAGE B
 U: ROADWAY AT RAMP U & V
 C: ROADWAY IN FRONT OF GARAGE C
 Y: ROADWAY AT RAMP Y

1 FRAMING PLAN - GRIDS 12-24 (BOTTOM)
 1/8" = 1'-0"

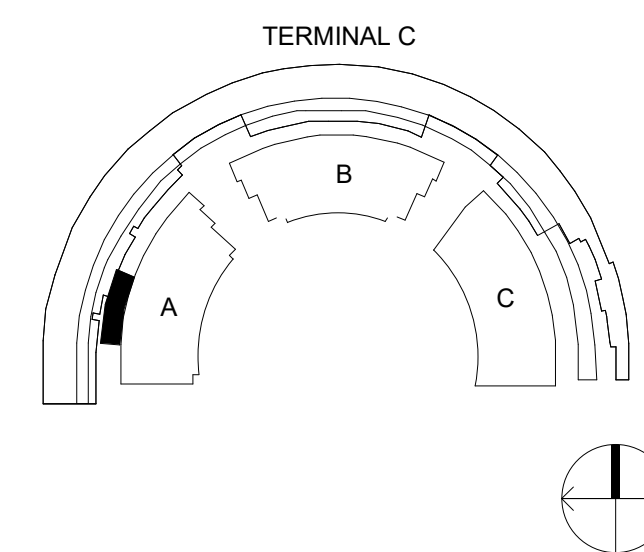

DFW DALLAS FORT WORTH INTERNATIONAL AIRPORT
 2330 N INTERNATIONAL PARKWAY
 DFW AIRPORT, TX 75261

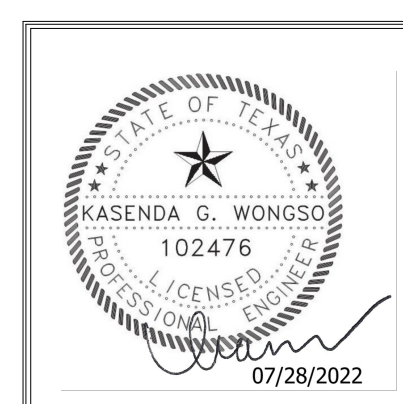

AG & E Structural Integrity
 PROJECT # 21084.00000
 15200 Addison Road, Suite 310
 Addison, Texas 75001
 Ph: 214.503.7802
 www.agne.com
 TX REG. NO. F-8439
 1-214-722-6000

DRAWN BY: ADD/GY
 APPROVED BY: KW
 ISSUE DATE: 2022-07-28

NOT FOR BID OR CONSTRUCTION

NO.	DATE	DESCRIPTION
2021-02-23	30% DESIGN	
2022-01-09	70% DESIGN	
2022-03-01	100% DESIGN	
2022-07-28	100% ISSUED FOR PERMIT (IFP)	

DFW TERMINAL C GARAGE AND ROADWAY
ROADWAY FRAMING PLAN - GRIDS 12-24 (BOTTOM)
 PROJECT NUMBER: TFD-007
 PERMIT NUMBER: B22-0023

SHEET NUMBER
S-143-900R

SCALE(S) AS NOTED ON THIS SHEET ARE BASED ON A FULL SIZE 30 X 42 SHEET.

OBSERVATION NOTE	OBSERVED CONDITION	REPAIR NOTE
TYP	CONTRACTOR TO NOTIFY EOR AFTER THE PAVEMENT IS MILLED OFF FOR TOP SLAB SURFACE OBSERVATION	
RA-T-26	JOINT SEAL FAILURE	REPLACE JOINT SEAL ON ROADWAY AND WALKWAY PER GENERAL NOTES
RA-T-27	PAVEMENT CRACKS	AFTER SURFACE MILLED OFF, REPAIR CRACKS PER GENERAL NOTES AND RESURFACE PAVEMENT
RA-T-28	PAVEMENT WEAR	AFTER SURFACE MILLED OFF, REPAIR CRACKS PER GENERAL NOTES AND RESURFACE PAVEMENT
RA-T-29	DECK SPALL	REPAIR CRACKS PER GENERAL NOTES
RA-T-30	DECK EXPOSED REBARS	REPAIR SPALLS PER GENERAL NOTES

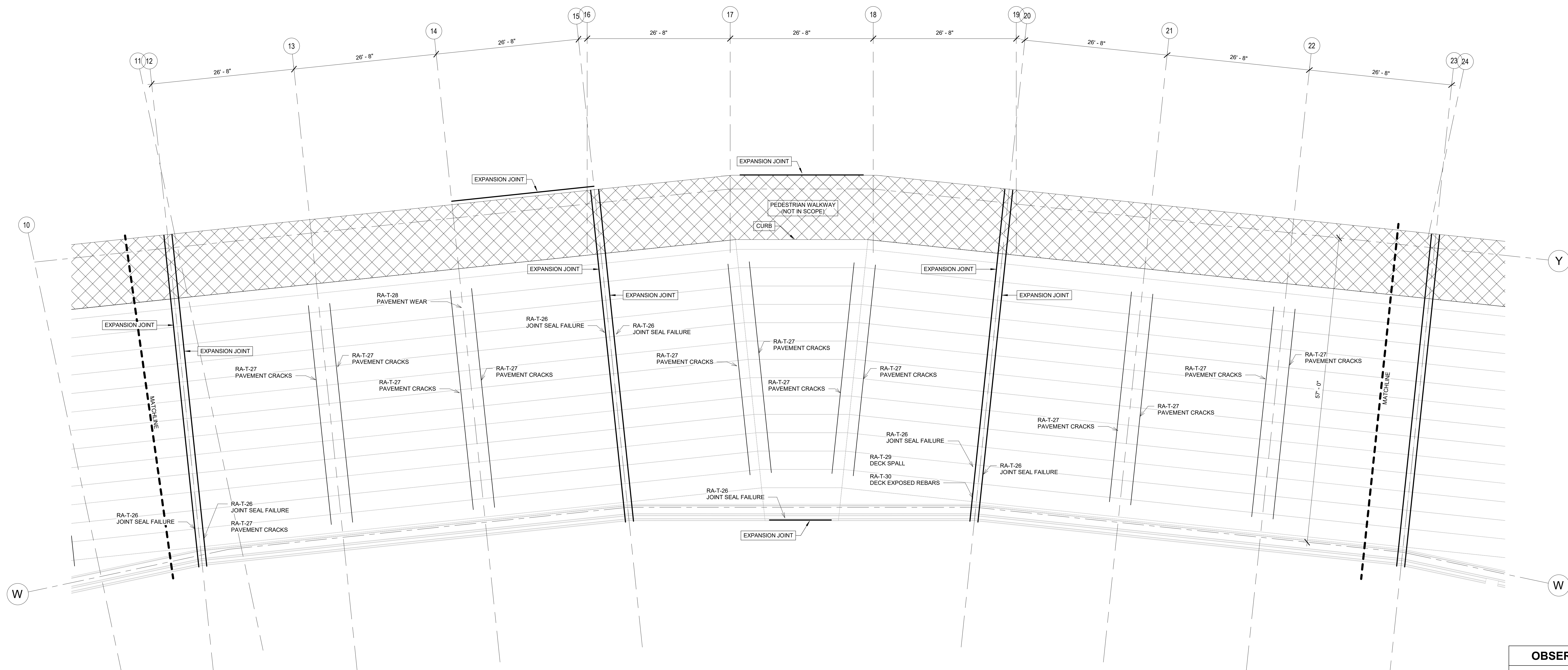

1 FRAMING PLAN - GRIDS 12-24 (TOP)
1/8" = 1'-0"

OBSERVATION NOTE KEY

RX-Y-ZZ

- 01-99: OBSERVATION NUMBER
- B: OBSERVATION FROM BOTTOM
- T: OBSERVATION FROM TOP
- M: ROADWAY AT RAMP M
- A: ROADWAY IN FRONT OF GARAGE A
- Q: ROADWAY AT RAMP Q & R
- B: ROADWAY IN FRONT OF GARAGE B
- U: ROADWAY AT RAMP U & V
- C: ROADWAY IN FRONT OF GARAGE C
- Y: ROADWAY AT RAMP Y

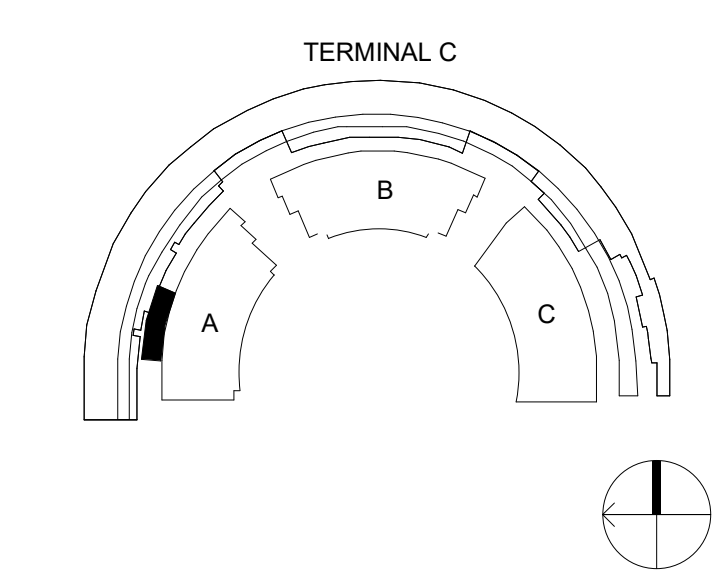

DFW DALLAS FORT WORTH INTERNATIONAL AIRPORT

2330 N INTERNATIONAL PARKWAY
DFW AIRPORT, TX 75261



AG & E Structural Engineers

PROJECT # 21084.00000
15200 Addison Road, Suite 310
Addison, Texas 75001
Ph: 214-503-7502
www.agne.com
TX REG. NO. F-8439
1-214-722-6000

DRAWN BY: ADD/GY
APPROVED BY: KW
ISSUE DATE: 2022-07-28

NOT FOR BID OR CONSTRUCTION

NO.	DATE	DESCRIPTION
2022-01-09	75% DESIGN	
2022-03-01	100% DESIGN	
2022-07-28	100% ISSUED FOR PERMIT (IFP)	

DFW TERMINAL C GARAGE AND ROADWAY

ROADWAY FRAMING PLAN - GRIDS 12-24 (TOP)

PROJECT NUMBER: TFD-007

PERMIT NUMBER: 822-0023

SHEET NUMBER
S-144-900R

SCALE(S) AS NOTED ON THIS SHEET ARE BASED ON A FULL SIZE 30 X 42 SHEET.

OBSERVATION NOTE	OBSERVED CONDITION	REPAIR NOTE
RA-B-51	GIRDER CRACKS	REPAIR CRACKS PER GENERAL NOTES
RA-B-52	GIRDER SPALL	REPAIR SPALLS PER GENERAL NOTES
RA-B-53	GIRDER EXPOSED REBARS	REPAIR SPALLS PER GENERAL NOTES
RA-B-54	GIRDER EFFLORESCENCE	CLEAN CONCRETE SURFACE
RA-B-55	SPANDREL BEAM CRACKS	REPAIR CRACKS PER GENERAL NOTES
RA-B-56	SPANDREL BEAM SPALL	REPAIR SPALLS PER GENERAL NOTES
RA-B-57	SPANDREL BEAM EFFLORESCENCE	CLEAN CONCRETE SURFACE
RA-B-58	OVERHANG CRACKS	REPAIR CRACKS PER GENERAL NOTES
RA-B-59	OVERHANG SPALL	REPAIR SPALLS PER GENERAL NOTES
RA-B-60	COLUMN CRACKS	REPAIR CRACKS PER GENERAL NOTES
RA-B-61	COLUMN SPALL	REPAIR SPALLS PER GENERAL NOTES
RA-B-62	COLUMN CAP CRACKS	REPAIR CRACKS PER GENERAL NOTES
RA-B-63	ANCHOR BOLTS AND ANGLE CORROSION	BEAD BLAST STEEL AND TOUCH UP WITH TMEC ZINC RICH PAINT

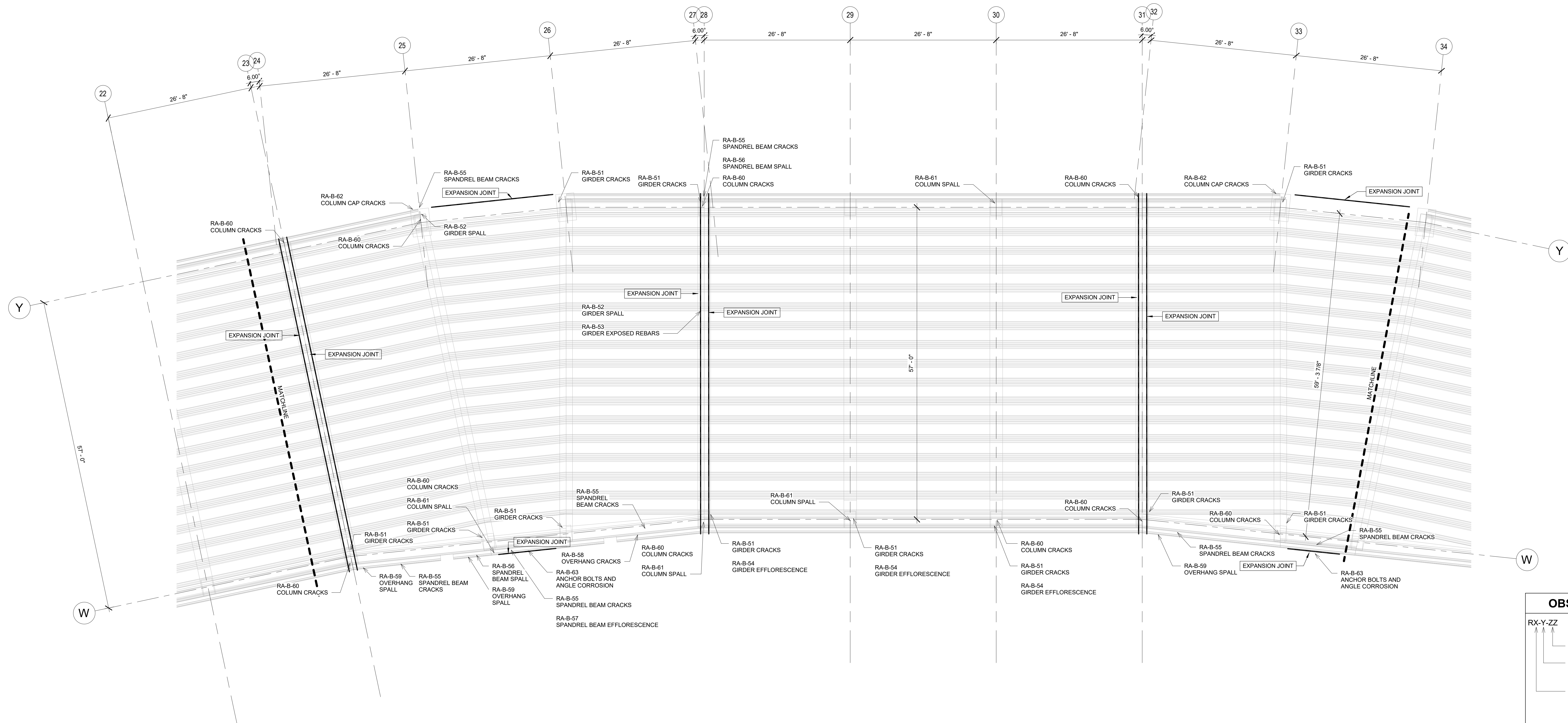

OBSERVATION NOTE KEY

RX-Y-ZZ
 01-99: OBSERVATION NUMBER
 B: OBSERVATION FROM BOTTOM
 T: OBSERVATION FROM TOP

M: ROADWAY AT RAMP M
 A: ROADWAY IN FRONT OF GARAGE A
 Q: ROADWAY AT RAMP Q & R
 B: ROADWAY IN FRONT OF GARAGE B
 U: ROADWAY AT RAMP U & V
 C: ROADWAY IN FRONT OF GARAGE C
 Y: ROADWAY AT RAMP Y

1 FRAMING PLAN - GRIDS 24-34 (BOTTOM)
 1/8" = 1'-0"

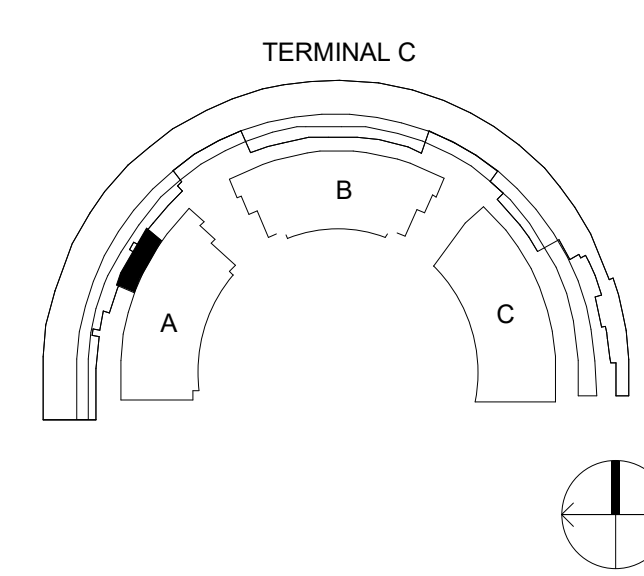

DFW DALLAS FORT WORTH INTERNATIONAL AIRPORT

2330 N INTERNATIONAL PARKWAY
 DFW AIRPORT, TX 75261



AG & E Structural Integrity

PROJECT # 21084.00000
 15200 Addison Road, Suite 310
 Addison, Texas 75001
 Ph: 214.503.7602
 www.agen.com
 TX REG. NO. F-8439
 1-214-722-6000

DRAWN BY: ADD/GY
 APPROVED BY: KW
 ISSUE DATE: 2022-07-28

NOT FOR BID OR CONSTRUCTION

NO.	DATE	DESCRIPTION
2021-10-23	30% DESIGN	
2022-01-09	70% DESIGN	
2022-03-01	100% DESIGN	
2022-07-28	100% ISSUED FOR PERMIT (IFP)	

DFW TERMINAL C GARAGE AND ROADWAY

ROADWAY FRAMING PLAN - GRIDS 24-34 (BOTTOM)

PROJECT NUMBER: TFD-007

PERMIT NUMBER: B22-0023

SHEET NUMBER
S-145-900R

SCALE(S) AS NOTED ON THIS SHEET ARE BASED ON A FULL SIZE 30 X 42 SHEET.

OBSERVATION NOTE	OBSERVED CONDITION	REPAIR NOTE
TYP	CONTRACTOR TO NOTIFY EOR AFTER THE PAVEMENT IS MILLED OFF FOR TOP SLAB SURFACE OBSERVATION	
RA-T-51	JOINT SEAL FAILURE	REPLACE JOINT SEAL ON ROADWAY AND WALKWAY PER GENERAL NOTES
RA-T-52	PAVEMENT WEAR	AFTER SURFACE MILLED OFF, REPAIR CRACKS PER GENERAL NOTES AND RESURFACE PAVEMENT
RA-T-53	PAVEMENT CRACKS	AFTER SURFACE MILLED OFF, REPAIR CRACKS PER GENERAL NOTE...
RA-T-54	DECK SPALL	REPAIR SPALLS PER GENERAL NOTES...

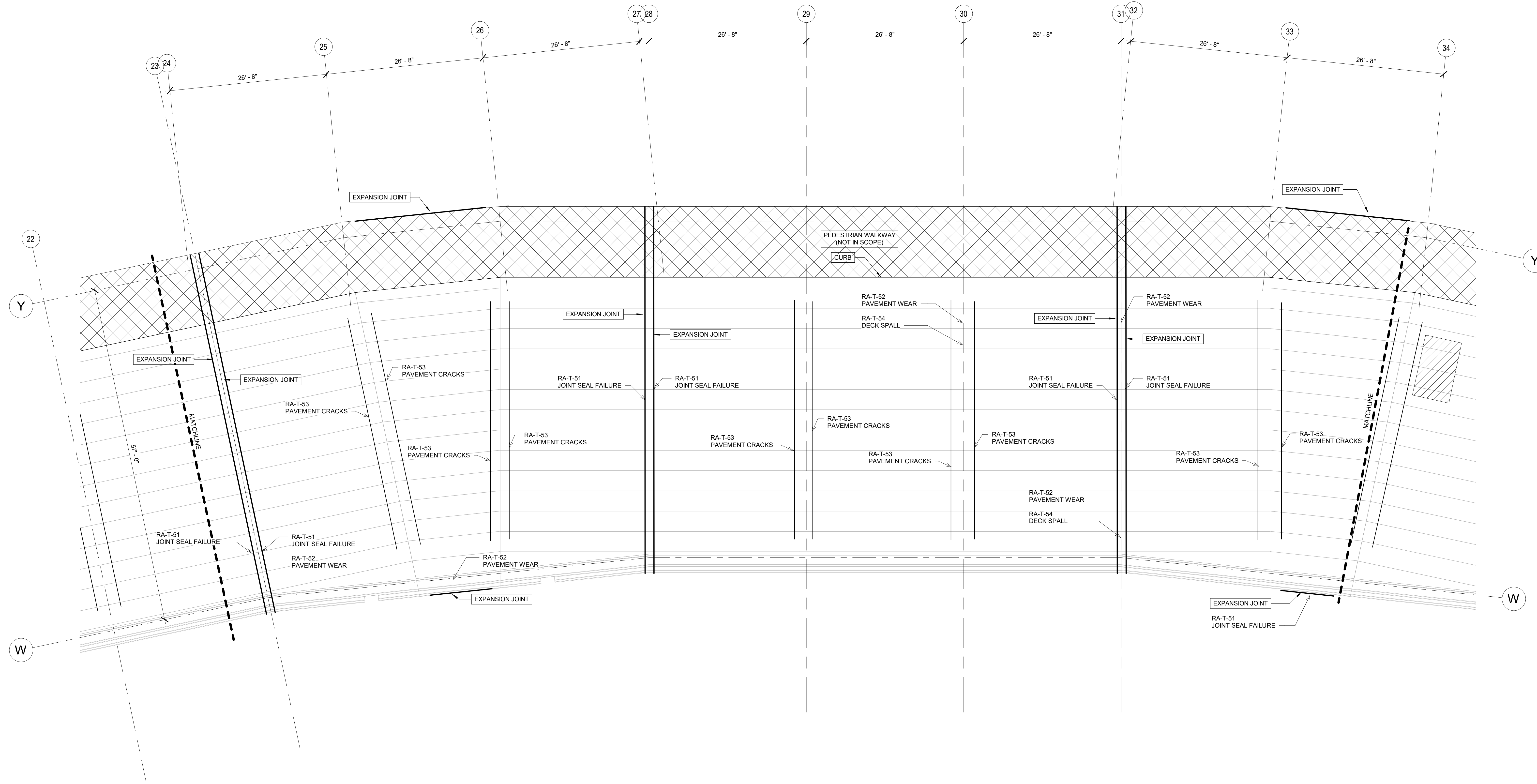

1 FRAMING PLAN - GRIDS 24-34 (TOP)
1/8" = 1'-0"

OBSERVATION NOTE KEY	
01-99:	OBSERVATION NUMBER
B:	OBSERVATION FROM BOTTOM
T:	OBSERVATION FROM TOP
M:	ROADWAY AT RAMP M
A:	ROADWAY IN FRONT OF GARAGE A
Q:	ROADWAY AT RAMP Q & R
B:	ROADWAY IN FRONT OF GARAGE B
U:	ROADWAY AT RAMP U & V
C:	ROADWAY IN FRONT OF GARAGE C
Y:	ROADWAY AT RAMP Y

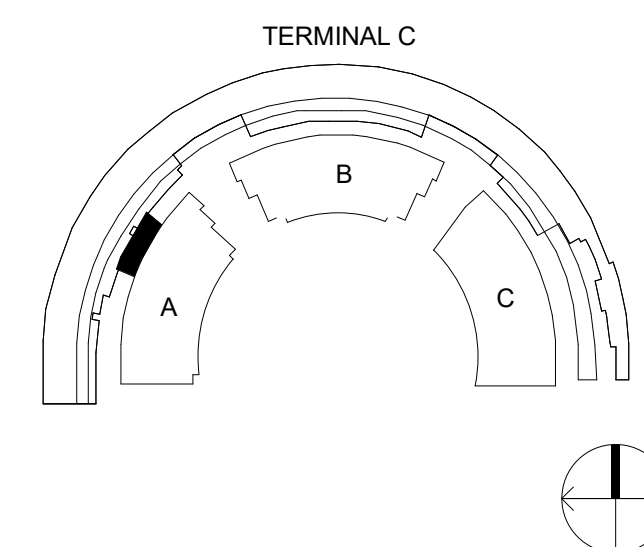

DFW DALLAS FORT WORTH INTERNATIONAL AIRPORT

2330 N INTERNATIONAL PARKWAY
DFW AIRPORT, TX 75261

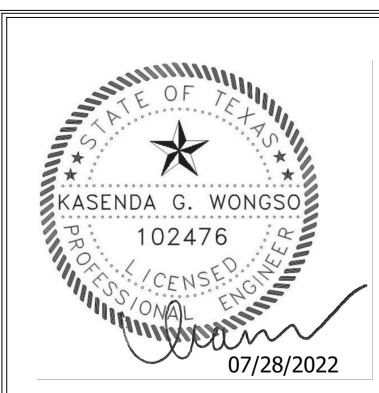

DRAWN BY: ADD/GY
APPROVED BY: KW
ISSUE DATE: 2022-07-28

NOT FOR BID OR CONSTRUCTION

NO.	DATE	DESCRIPTION
2022-01-09	75% DESIGN	
2022-03-01	100% DESIGN	
2022-07-28	100% ISSUED FOR PERMIT (IFP)	

PROJECT NUMBER: TFD-007

DFW TERMINAL C GARAGE AND ROADWAY
ROADWAY FRAMING PLAN - GRIDS 24-34 (TOP)

PERMIT NUMBER: B22-0023

SHEET NUMBER
S-146-900R

SCALE(S) AS NOTED ON THIS SHEET ARE BASED ON A FULL SIZE 30 X 42 SHEET.

OBSERVATION NOTE	OBSERVED CONDITION	REPAIR NOTE
RA-B-76	GIRDER CRACKS	REPAIR CRACKS PER GENERAL NOTES
RA-B-77	GIRDER SPALL	REPAIR SPALLS PER GENERAL NOTES
RA-B-78	GIRDER EXPOSED REBARS	REPAIR SPALLS PER GENERAL NOTES
RA-B-79	GIRDER EFFLORESCENCE	CLEAN CONCRETE SURFACE
RA-B-80	SPANDREL BEAM CRACKS	REPAIR CRACKS PER GENERAL NOTES
RA-B-81	SPANDREL BEAM SPALL	REPAIR SPALLS PER GENERAL NOTES
RA-B-82	SPANDREL BEAM EFFLORESCENCE	CLEAN CONCRETE SURFACE
RA-B-83	COLUMN CRACKS	REPAIR CRACKS PER GENERAL NOTES
RA-B-84	COLUMN SPALL	REPAIR SPALLS PER GENERAL NOTES
RA-B-85	COLUMN CAP CRACKS	REPAIR CRACKS PER GENERAL NOTES
RQ-B-01	COLUMN CRACKS	REPAIR CRACKS PER GENERAL NOTES
RQ-B-02	COLUMN SPALL	REPAIR SPALLS PER GENERAL NOTES
RQ-B-03	COLUMN EFFLORESCENCE	CLEAN CONCRETE SURFACE
RQ-B-04	GIRDER CRACKS	REPAIR CRACKS PER GENERAL NOTES
RQ-B-05	GIRDER SPALL	REPAIR SPALLS PER GENERAL NOTES
RQ-B-06	GIRDER EXPOSED REBARS	REPAIR SPALLS PER GENERAL NOTES
RQ-B-07	DECK CRACKS	REPAIR CRACKS PER GENERAL NOTES
RQ-B-08	DECK EFFLORESCENCE	CLEAN CONCRETE SURFACE
RQ-B-09	DECK SPALL	REPAIR SPALLS PER GENERAL NOTES

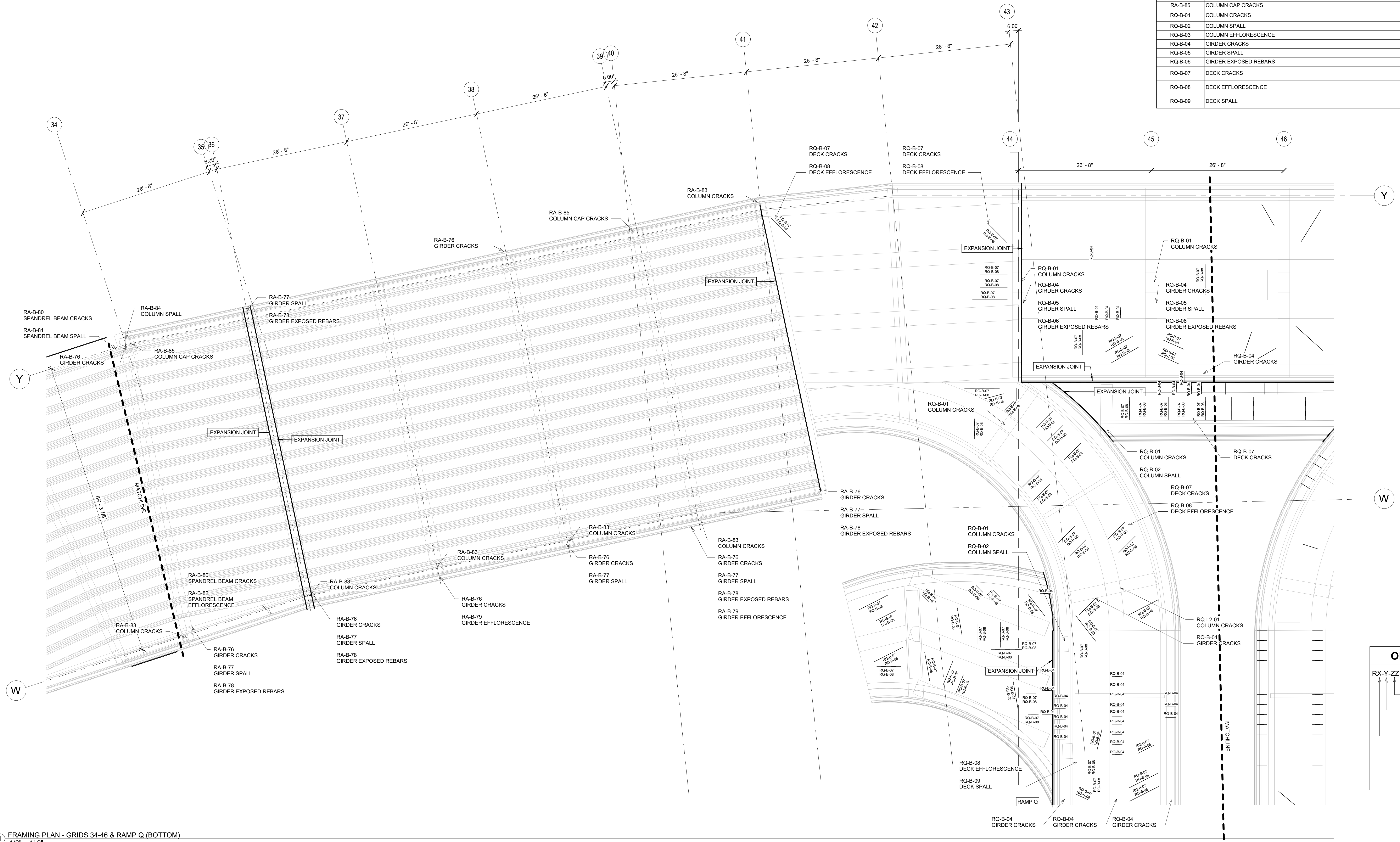

OBSERVATION NOTE KEY	
RX-Y-ZZ	01-99: OBSERVATION NUMBER
B:	OBSERVATION FROM BOTTOM
T:	OBSERVATION FROM TOP
M:	ROADWAY AT RAMP M
A:	ROADWAY IN FRONT OF GARAGE A
Q:	ROADWAY AT RAMP Q & R
B:	ROADWAY IN FRONT OF GARAGE B
U:	ROADWAY AT RAMP U & V
C:	ROADWAY IN FRONT OF GARAGE C
Y:	ROADWAY AT RAMP Y

1 FRAMING PLAN - GRIDS 34-46 & RAMP Q (BOTTOM)
1/8" = 1'-0"

DFW DALLAS FORT WORTH INTERNATIONAL AIRPORT
2330 N INTERNATIONAL PARKWAY
DFW AIRPORT, TX 75261



PROJECT # 21084.00000
15200 Addison Road, Suite 310
Addison, Texas 75001
Ph: 214.503.7802
www.agne.com
TX REG. NO. F-8459
Structural Integrity

DRAWN BY: ADD/GY
APPROVED BY: KW
ISSUE DATE: 2022-07-28

NOT FOR BID OR CONSTRUCTION

NO.	DATE	DESCRIPTION
2021-10-23	30% DESIGN	
2022-01-09	70% DESIGN	
2022-03-01	100% DESIGN	
2022-07-28	100% ISSUED FOR PERMIT (IFP)	

DFW TERMINAL C GARAGE AND ROADWAY
ROADWAY FRAMING PLAN - GRIDS 34-46 & RAMP Q (BOTTOM)
PROJECT NUMBER: TFD-007
PERMIT NUMBER: 822-0023

SHEET NUMBER
S-147-900R

SCALE(S) AS NOTED ON THIS SHEET ARE BASED ON A FULL SIZE 30 X 42 SHEET.

OBSERVATION NOTE	OBSERVED CONDITION	REPAIR NOTE
TYP	CONTRACTOR TO NOTIFY EOR AFTER THE PAVEMENT IS MILLED OFF FOR TOP SLAB SURFACE OBSERVATION	
RA-T-76	JOINT SEAL FAILURE	REPLACE JOINT SEAL ON ROADWAY AND WALKWAY PER GENERAL NOTES
RA-T-77	PAVEMENT CRACKS	AFTER SURFACE MILLED OFF, REPAIR CRACKS PER GENERAL NOTES AND RESURFACE PAVEMENT...
RA-T-78	PAVEMENT WEAR	AFTER SURFACE MILLED OFF, REPAIR CRACKS PER GENERAL NOTES AND RESURFACE PAVEMENT...
RQ-T-01	JOINT SEAL FAILURE	REPLACE JOINT SEAL ON ROADWAY AND WALKWAY PER GENERAL NOTES
RQ-T-02	PAVEMENT CRACKS	AFTER SURFACE MILLED OFF, REPAIR CRACKS PER GENERAL NOTES AND RESURFACE PAVEMENT
RQ-T-03	PAVEMENT WEAR	AFTER SURFACE MILLED OFF, REPAIR CRACKS PER GENERAL NOTES AND RESURFACE PAVEMENT
RQ-T-04	DECK CRACKS	REPAIR CRACKS PER GENERAL NOTES
RQ-T-05	DECK SPALL	REPAIR SPALLS PER GENERAL NOTES
RQ-T-06	DIFFERENTIAL SLAB ELEVATIONS	LEVEL SLAB WITH TOPPING MORTAR PER GENERAL NOTES AND RESURFACE PAVEMENT
RQ-T-07	RAILING PARAPET WALL CRACKS	REPAIR CRACKS PER GENERAL NOTES...
RQ-T-08	RAILING PARAPET WALL SPALL	REPAIR SPALLS PER GENERAL NOTES
RQ-T-09	DECK EXPOSED REBARS	REPAIR SPALLS PER GENERAL NOTES

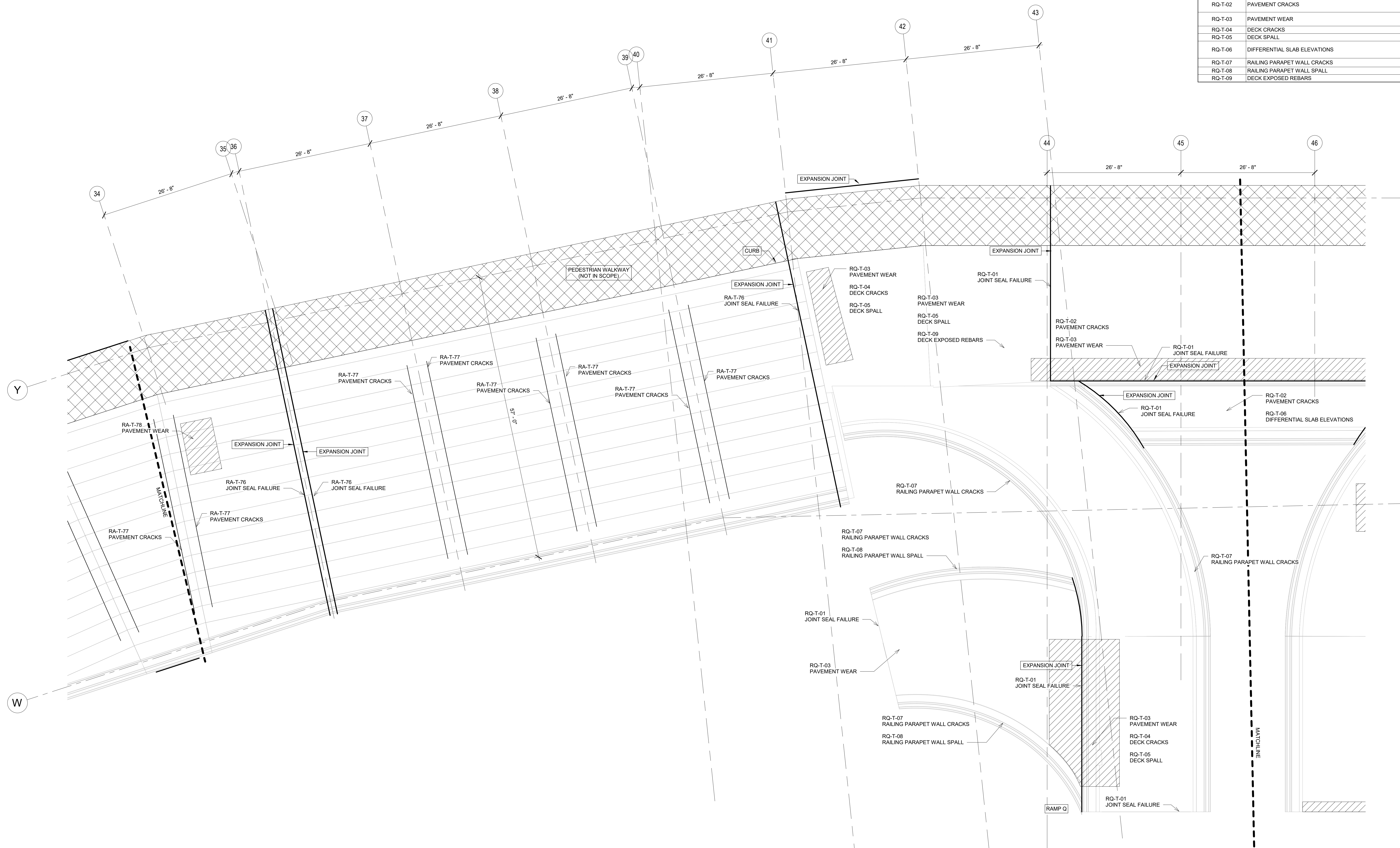

OBSERVATION NOTE KEY

RX-Y-ZZ
 01-99: OBSERVATION NUMBER
 B: OBSERVATION FROM BOTTOM
 T: OBSERVATION FROM TOP

M: ROADWAY AT RAMP M
 A: ROADWAY IN FRONT OF GARAGE A
 Q: ROADWAY AT RAMP Q & R
 B: ROADWAY IN FRONT OF GARAGE B
 U: ROADWAY AT RAMP U & V
 C: ROADWAY IN FRONT OF GARAGE C
 Y: ROADWAY AT RAMP Y

1 FRAMING PLAN - GRIDS 34-46 & RAMP Q (TOP)
 1/8" = 1'-0"

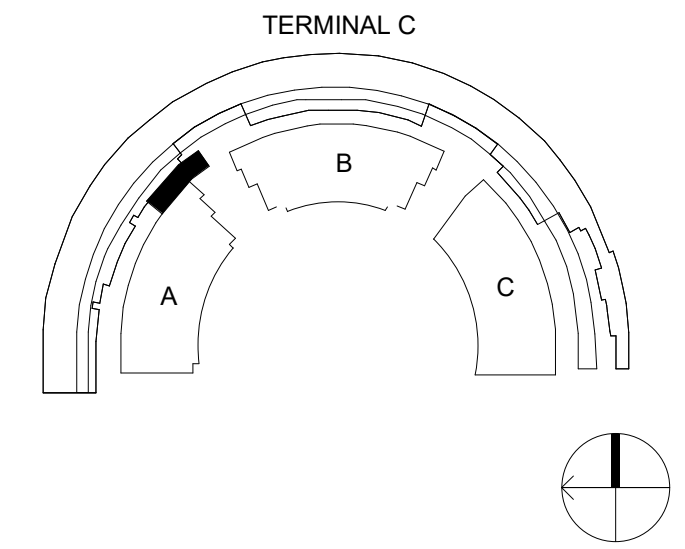

DFW DALLAS FORT WORTH INTERNATIONAL AIRPORT

2330 N INTERNATIONAL PARKWAY
 DFW AIRPORT, TX 75261



PROJECT # 21084.00000
 15200 Addison Road, Suite 310
 Addison, Texas 75001
 Ph: 214.503.7802
 www.ageno.com
 TX REG. NO. F-8439
 1-214-722-6000

AG & E
 Structural Emulity

DRAWN BY: ADD/GY
 APPROVED BY: KW
 ISSUE DATE: 2022-07-28

NOT FOR BID OR CONSTRUCTION

NO.	DATE	DESCRIPTION
2022-01-09	75% DESIGN	
2022-03-01	100% DESIGN	
2022-07-28	100% ISSUED FOR PERMIT (IFP)	

DFW TERMINAL C GARAGE AND ROADWAY

ROADWAY FRAMING PLAN - GRIDS 34-46 & RAMP Q (TOP)

PROJECT NUMBER: TFD-007

PERMIT NUMBER: B22-0023

SHEET NUMBER

S-148-900R

SCALE(S) AS NOTED ON THIS SHEET ARE BASED ON A FULL SIZE 30 X 42 SHEET.

OBSERVATION NOTE	OBSERVED CONDITION	REPAIR NOTE
RQ-B-26	COLUMN CRACKS	REPAIR CRACKS PER GENERAL NOTES
RQ-B-27	COLUMN SPALL	REPAIR SPALLS PER GENERAL NOTES
RQ-B-28	COLUMN EFFLORESCENCE	CLEAN CONCRETE SURFACE
RQ-B-29	GIRDER CRACKS	REPAIR CRACKS PER GENERAL NOTES
RQ-B-30	GIRDER EFFLORESCENCE	CLEAN CONCRETE SURFACE
RQ-B-31	GIRDER SPALL	REPAIR SPALLS PER GENERAL NOTES
RQ-B-32	DECK CRACKS	REPAIR CRACKS PER GENERAL NOTES
RQ-B-33	DECK EFFLORESCENCE	CLEAN CONCRETE SURFACE
RQ-B-34	DECK SPALL	REPAIR SPALLS PER GENERAL NOTES
RB-B-01	COLUMN CRACKS	REPAIR CRACKS PER GENERAL NOTES
RB-B-02	COLUMN EFFLORESCENCE	CLEAN CONCRETE SURFACE
RB-B-03	COLUMN SPALL	REPAIR SPALLS PER GENERAL NOTES
RB-B-04	COLUMN EXPOSED REBARS	REPAIR SPALLS PER GENERAL NOTES
RB-B-05	GIRDER CRACKS	REPAIR CRACKS PER GENERAL NOTES
RB-B-06	GIRDER EFFLORESCENCE	CLEAN CONCRETE SURFACE
RB-B-07	GIRDER SPALL	REPAIR SPALLS PER GENERAL NOTES
RB-B-08	GIRDER EXPOSED REBARS	REPAIR SPALLS PER GENERAL NOTES
RB-B-09	OVERHANG SPALL	REPAIR SPALLS PER GENERAL NOTES
RB-B-10	DOWNSPOUT OPENING	FILL OPENING WITH MATERIAL PER GENERAL NOTES
RB-B-11	ANCHOR BOLTS AND ANGLE CORROSION	BEAD BLAST STEEL AND TOUCH UP WITH TNEC ZINC RICH PAINT
RB-B-12	OVERHANG CRACKS	REPAIR CRACKS PER GENERAL NOTES



OBSERVATION NOTE KEY

RX-Y-ZZ

01-99: OBSERVATION NUMBER

B: OBSERVATION FROM BOTTOM

T: OBSERVATION FROM TOP

M: ROADWAY AT RAMP M

A: ROADWAY IN FRONT OF GARAGE A

Q: ROADWAY AT RAMP Q & R

B: ROADWAY IN FRONT OF GARAGE B

U: ROADWAY AT RAMP U & V

C: ROADWAY IN FRONT OF GARAGE C

Y: ROADWAY AT RAMP Y

1 FRAMING PLAN - GRIDS 46-57 & RAMP R (BOTTOM)
1/8" = 1'-0"

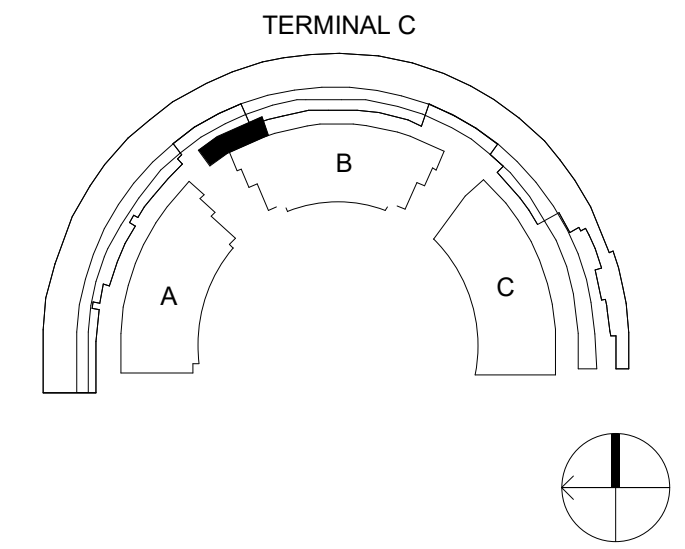

2330 N INTERNATIONAL PARKWAY
DFW AIRPORT, TX 75261

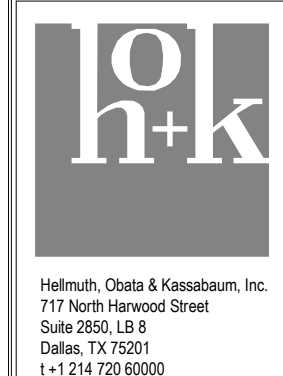
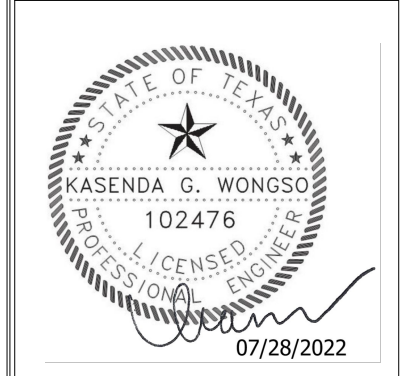

DRAWN BY: ADD/GY
APPROVED BY: KW
ISSUE DATE: 2022-07-28

NOT FOR BID OR CONSTRUCTION

NO.	DATE	DESCRIPTION
2021-02-23	30% DESIGN	
2022-01-09	70% DESIGN	
2022-03-01	100% DESIGN	
2022-07-28	100% ISSUED FOR PERMIT (IFP)	

DFW TERMINAL C GARAGE AND ROADWAY
ROADWAY FRAMING PLAN - GRIDS 46-57 & RAMP R (BOTTOM)

PROJECT NUMBER: TFD-007

PERMIT NUMBER: B22-0023

SHEET NUMBER
S-149-900R

SCALE(S) AS NOTED ON THIS SHEET ARE BASED ON A FULL SIZE 30 X 42 SHEET.

OBSERVATION NOTE	OBSERVED CONDITION	REPAIR NOTE
TYP	CONTRACTOR TO NOTIFY EOR AFTER THE PAVEMENT IS MILLED OFF FOR TOP SLAB SURFACE OBSERVATION	
RQ-T-26	JOINT SEAL FAILURE	REPLACE JOINT SEAL ON ROADWAY AND WALKWAY PER GENERAL NOTES
RQ-T-27	PAVEMENT CRACKS	AFTER SURFACE MILLED OFF, REPAIR CRACKS PER GENERAL NOTES AND RESURFACE PAVEMENT
RQ-T-28	PAVEMENT WEAR	AFTER SURFACE MILLED OFF, REPAIR CRACKS PER GENERAL NOTES AND RESURFACE PAVEMENT
RQ-T-29	DECK SPALL	REPAIR SPALLS PER GENERAL NOTES
RQ-T-30	RAILING PARAPET WALL CRACKS	REPAIR CRACKS PER GENERAL NOTES
RQ-T-31	RAILING PARAPET WALL SPALL	REPAIR SPALLS PER GENERAL NOTES
RQ-T-32	RAILING CRACK	WELD AROUND STEEL TUBE AND PAINT
RQ-T-33	RAILING DAMAGE	COVER OPENING WITH 1/4-INCH STEEL PLATE AND PAINT
RQ-T-34	DECK EXPOSED REBARS	REPAIR SPALLS PER GENERAL NOTES
RB-T-01	JOINT SEAL FAILURE	REPLACE JOINT SEAL ON ROADWAY AND WALKWAY PER GENERAL NOTES
RB-T-02	PAVEMENT CRACKS	AFTER SURFACE MILLED OFF, REPAIR CRACKS PER GENERAL NOTES AND RESURFACE PAVEMENT
RB-T-03	PAVEMENT WEAR	AFTER SURFACE MILLED OFF, REPAIR CRACKS PER GENERAL NOTES AND RESURFACE PAVEMENT
RB-T-04	RAILING PARAPET WALL SPALL	REPAIR SPALLS PER GENERAL NOTES

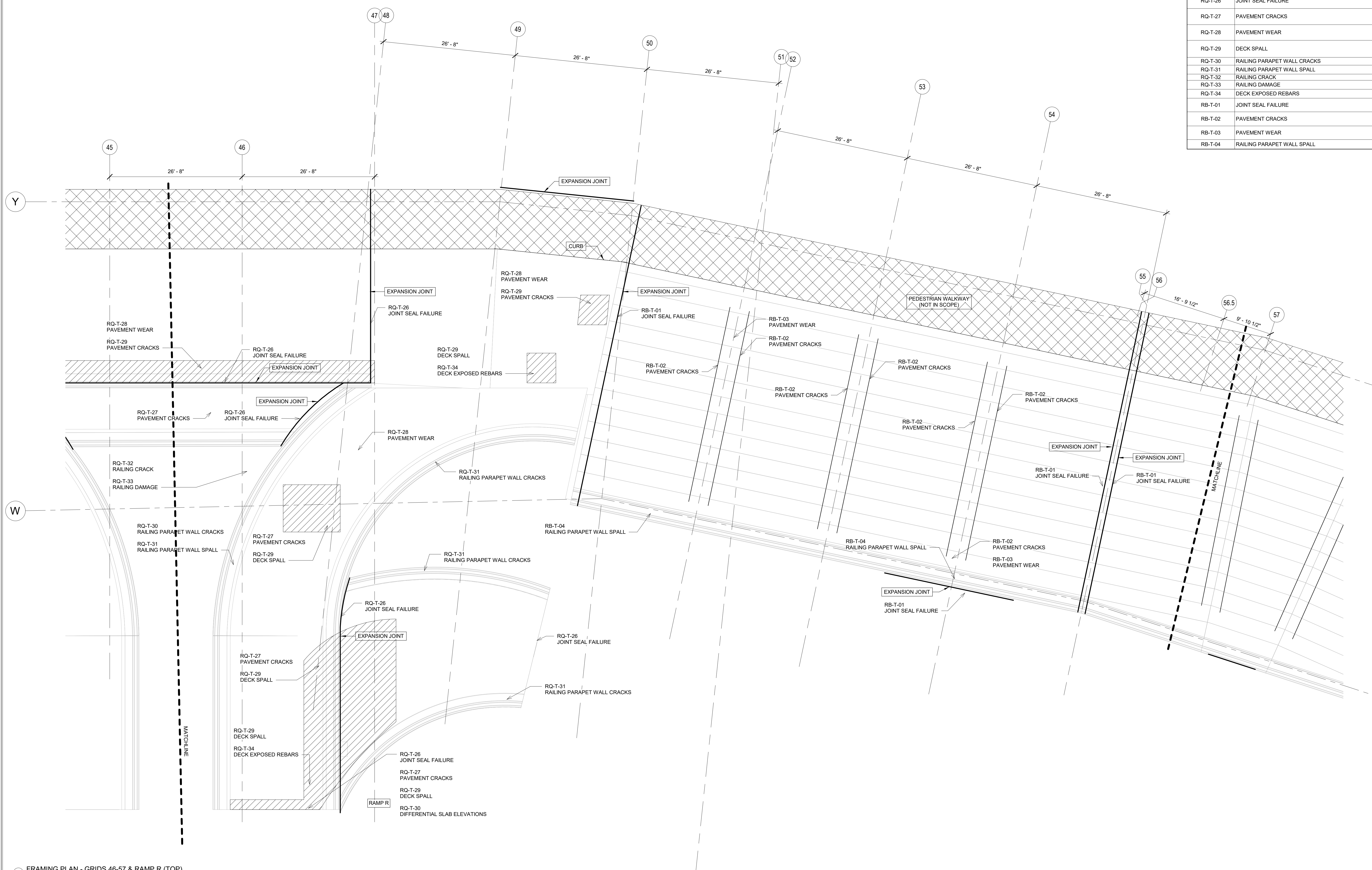

1 FRAMING PLAN - GRIDS 46-57 & RAMP R (TOP)
1/8" = 1'-0"

OBSERVATION NOTE KEY	
RX-Y-ZZ	01-99: OBSERVATION NUMBER
B:	OBSERVATION FROM BOTTOM
T:	OBSERVATION FROM TOP
M:	ROADWAY AT RAMP M
A:	ROADWAY IN FRONT OF GARAGE A
Q:	ROADWAY AT RAMP Q & R
B:	ROADWAY IN FRONT OF GARAGE B
U:	ROADWAY AT RAMP U & V
C:	ROADWAY IN FRONT OF GARAGE C
Y:	ROADWAY AT RAMP Y

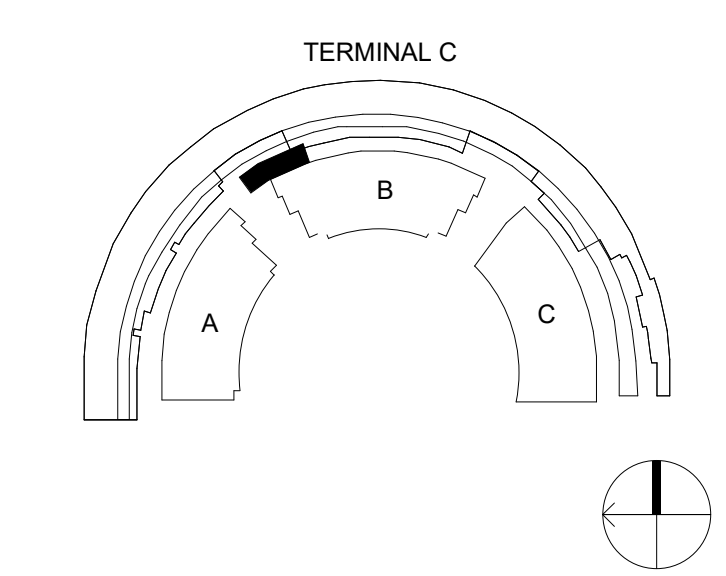

2330 N INTERNATIONAL PARKWAY
DFW AIRPORT, TX 75261

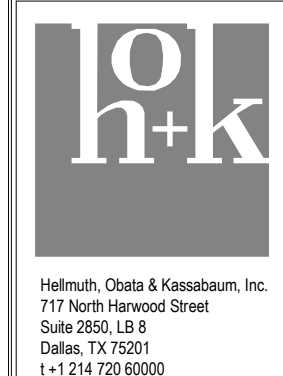
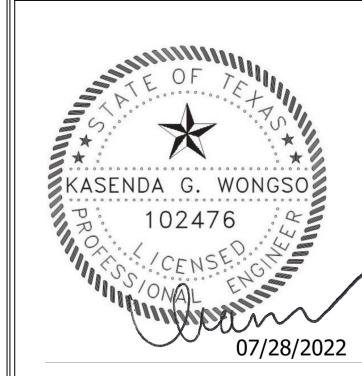

DRAWN BY: ADD/GY
APPROVED BY: KW
ISSUE DATE: 2022-07-28

NOT FOR BID OR CONSTRUCTION

NO.	DATE	DESCRIPTION
2022-01-09		75% DESIGN
2022-03-01		100% DESIGN
2022-07-28		100% ISSUED FOR PERMIT (IFP)

DFW TERMINAL C GARAGE AND ROADWAY

ROADWAY FRAMING PLAN - GRIDS 46-57 & RAMP R (TOP)

PROJECT NUMBER: TFD-007

PERMIT NUMBER: B22-0023

SHEET NUMBER
S-150-900R

SCALE(S) AS NOTED ON THIS SHEET ARE BASED ON A FULL SIZE 30 X 42 SHEET.

OBSERVATION NOTE	OBSERVED CONDITION	REPAIR NOTE
RB-B-26	COLUMN CRACKS	REPAIR CRACKS PER GENERAL NOTES
RB-B-27	COLUMN SPALL	REPAIR SPALLS PER GENERAL NOTES
RB-B-28	COLUMN EFFLORESCENCE	CLEAN CONCRETE SURFACE
RB-B-29	COLUMN CAP CRACKS	REPAIR CRACKS PER GENERAL NOTES
RB-B-30	GIRDER CRACKS	REPAIR CRACKS PER GENERAL NOTES
RB-B-31	GIRDER EFFLORESCENCE	CLEAN CONCRETE SURFACE
RB-B-32	GIRDER SPALL	REPAIR SPALLS PER GENERAL NOTES
RB-B-33	SPANDREL BEAM CRACKS	REPAIR CRACKS PER GENERAL NOTES
RB-B-34	SPANDREL BEAM EFFLORESCENCE	CLEAN CONCRETE SURFACE
RB-B-35	OVERHANG CRACKS	REPAIR CRACKS PER GENERAL NOTES
RB-B-36	OVERHANG SPALL	REPAIR SPALLS PER GENERAL NOTES
RB-B-37	ANCHOR BOLTS AND ANGLE CORROSION	BEAD BLAST STEEL AND TOUCH UP WITH TNMEC ZINC RICH PAINT

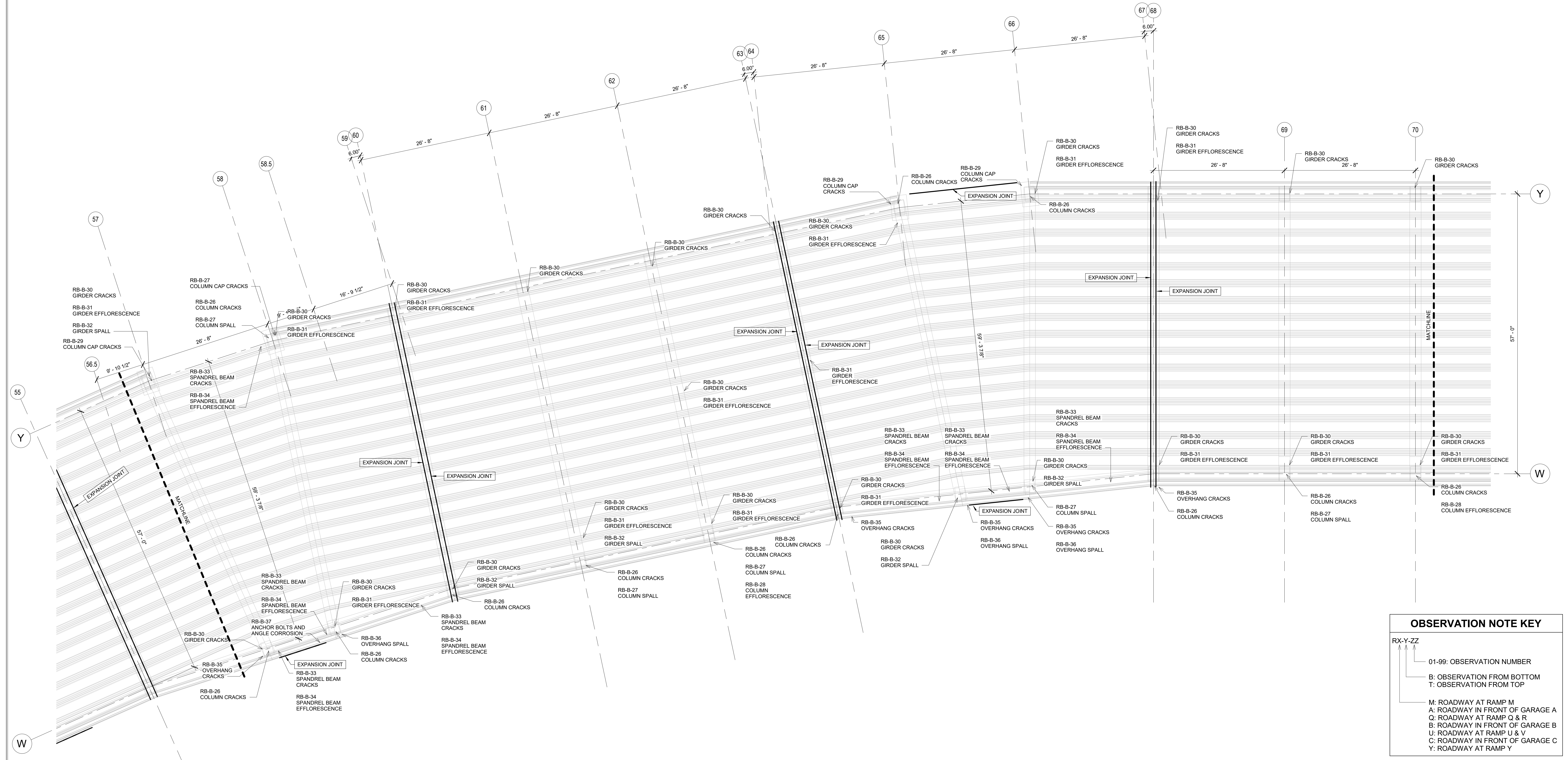

1 FRAMING PLAN - GRIDS 57-70 (BOTTOM)
1/8" = 1'-0"

OBSERVATION NOTE KEY

RX-Y-ZZ
 01-99: OBSERVATION NUMBER
 B: OBSERVATION FROM BOTTOM
 T: OBSERVATION FROM TOP
 M: ROADWAY AT RAMP M
 A: ROADWAY IN FRONT OF GARAGE A
 Q: ROADWAY AT RAMP Q & R
 B: ROADWAY IN FRONT OF GARAGE B
 U: ROADWAY AT RAMP U & V
 C: ROADWAY IN FRONT OF GARAGE C
 Y: ROADWAY AT RAMP Y



2330 N INTERNATIONAL PARKWAY
DFW AIRPORT, TX 75261

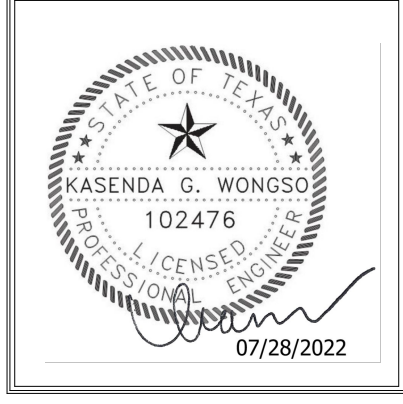

PROJECT # 21084.00000
15200 Addison Road, Suite 310
Addison, Texas 75001
Ph: 214.503.7002
www.agnie.com
TX REG. NO. F-8439
1-214-722-6000

DRAWN BY: ADD/GY
APPROVED BY: KW
ISSUE DATE: 2022-07-28

NOT FOR BID OR CONSTRUCTION

NO.	DATE	DESCRIPTION
2021-02-23	30% DESIGN	
2022-01-09	70% DESIGN	
2022-03-01	100% DESIGN	
2022-07-28	100% ISSUED FOR PERMIT (IFP)	

DFW TERMINAL C GARAGE AND ROADWAY
ROADWAY FRAMING PLAN - GRIDS 57-70 (BOTTOM)
 PROJECT NUMBER: TFD-007
 PERMIT NUMBER: B22-0023

SHEET NUMBER
S-151-900R

SCALE(S) AS NOTED ON THIS SHEET ARE BASED ON A FULL SIZE 30 X 42 SHEET.

OBSERVATION NOTE	OBSERVED CONDITION	REPAIR NOTE
TYP	CONTRACTOR TO NOTIFY EOR AFTER THE PAVEMENT IS MILLED OFF FOR TOP SLAB SURFACE OBSERVATION	
RB-T-26	JOINT SEAL FAILURE	REPLACE JOINT SEAL ON ROADWAY AND WALKWAY PER GENERAL NOTES
RB-T-27	PAVEMENT CRACKS	AFTER SURFACE MILLED OFF, REPAIR CRACKS PER GENERAL NOTES AND RESURFACE PAVEMENT
RB-T-28	PAVEMENT WEAR	AFTER SURFACE MILLED OFF, REPAIR CRACKS PER GENERAL NOTES AND RESURFACE PAVEMENT

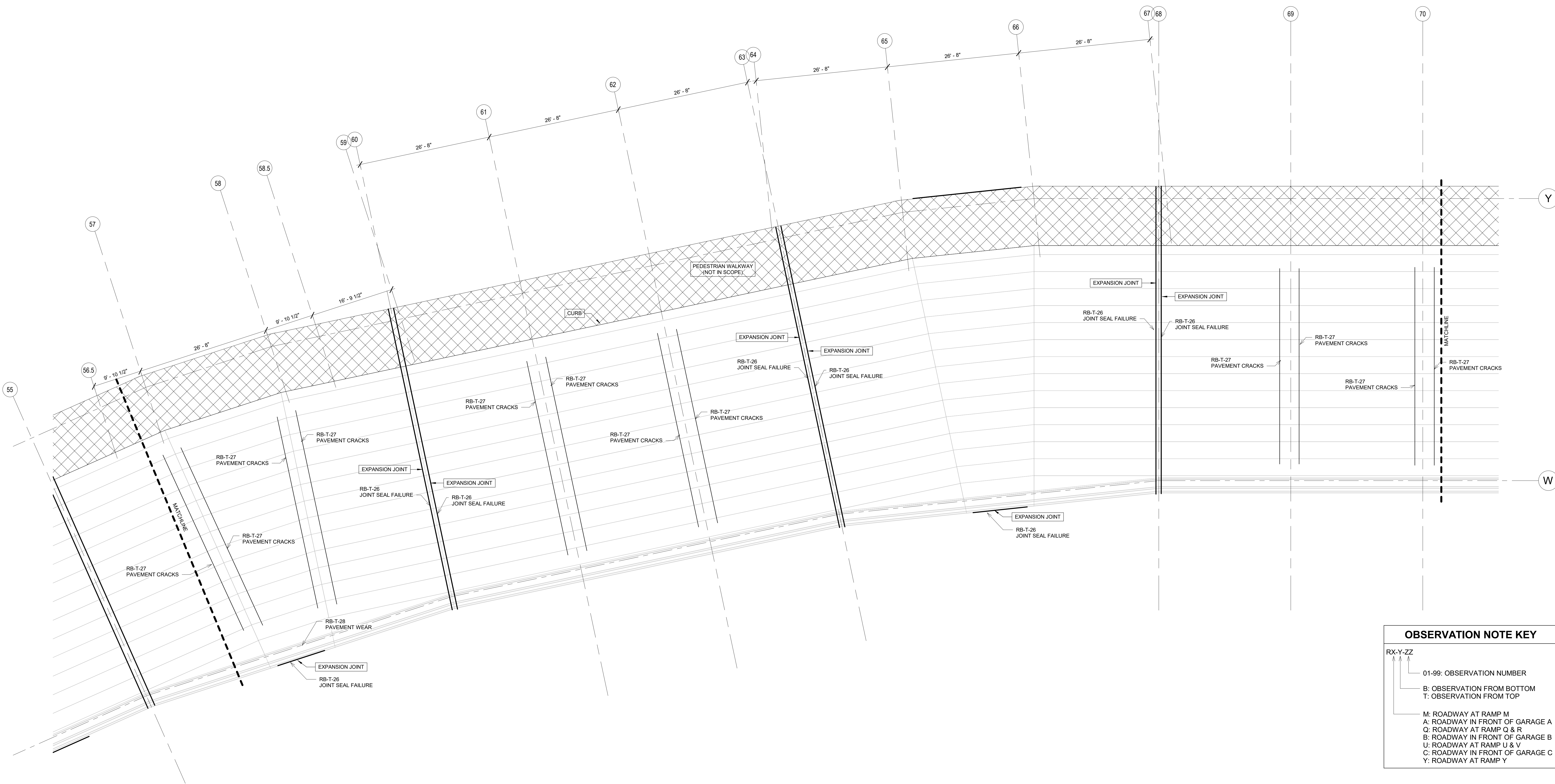

1 FRAMING PLAN - GRIDS 57-70 (TOP)
1/8" = 1'-0"

OBSERVATION NOTE KEY

RX-Y-ZZ
 01-99: OBSERVATION NUMBER
 B: OBSERVATION FROM BOTTOM
 T: OBSERVATION FROM TOP

M: ROADWAY AT RAMP M
 A: ROADWAY IN FRONT OF GARAGE A
 Q: ROADWAY AT RAMP Q & R
 B: ROADWAY IN FRONT OF GARAGE B
 U: ROADWAY AT RAMP U & V
 C: ROADWAY IN FRONT OF GARAGE C
 Y: ROADWAY AT RAMP Y

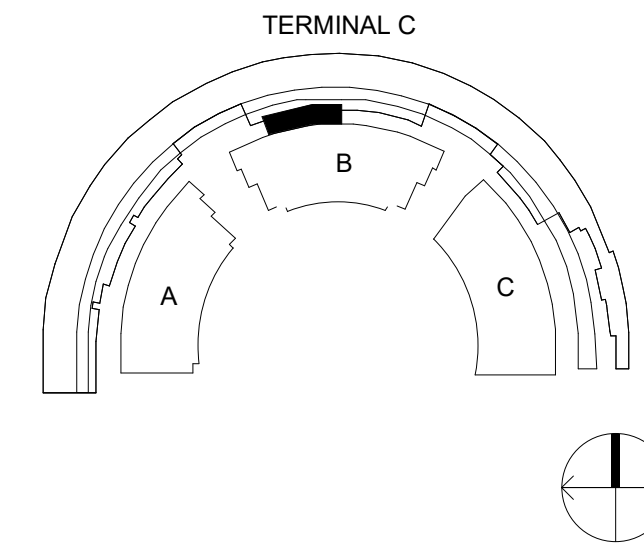

DFW DALLAS FORT WORTH INTERNATIONAL AIRPORT
 2330 N INTERNATIONAL PARKWAY
 DFW AIRPORT, TX 75261



AG & E
 PROJECT # 21084.00000
 15200 Addison Road, Suite 310
 Addison, Texas 75001
 Ph: 214-502-7802
 www.agne.com
 TX REG. NO. F-8439
 Structural Engenuity

DRAWN BY: ADD/GY
 APPROVED BY: KW
 ISSUE DATE: 2022-07-28

NOT FOR BID OR CONSTRUCTION

NO.	DATE	DESCRIPTION
2022-01-09	75% DESIGN	
2022-03-01	100% DESIGN	
2022-07-28	100% ISSUED FOR PERMIT (IFP)	

DFW TERMINAL C GARAGE AND ROADWAY
ROADWAY FRAMING PLAN - GRIDS 57-70 (TOP)
 PROJECT NUMBER: TFD-007
 PERMIT NUMBER: 622-0023

SHEET NUMBER
S-152-900R

SCALE(S) AS NOTED ON THIS SHEET ARE BASED ON A FULL SIZE 30 X 42 SHEET.

OBSERVATION NOTE	OBSERVED CONDITION	REPAIR NOTE
RB-B-51	COLUMN CRACKS	REPAIR CRACKS PER GENERAL NOTES
RB-B-52	COLUMN SPALL	REPAIR SPALLS PER GENERAL NOTES
RB-B-53	COLUMN EFFLORESCENCE	CLEAN CONCRETE SURFACE
RB-B-54	COLUMN CAP CRACKS	REPAIR CRACKS PER GENERAL NOTES
RB-B-55	GIRDER CRACKS	REPAIR CRACKS PER GENERAL NOTES
RB-B-56	GIRDER EFFLORESCENCE	CLEAN CONCRETE SURFACE
RB-B-57	GIRDER SPALL	REPAIR SPALLS PER GENERAL NOTES
RB-B-58	GIRDER EXPOSED REBARS	REPAIR SPALLS PER GENERAL NOTES
RB-B-59	SPANDREL BEAM CRACKS	REPAIR SPALLS PER GENERAL NOTES
RB-B-60	SPANDREL BEAM SPALL	REPAIR SPALLS PER GENERAL NOTES
RB-B-61	SPANDREL BEAM EXPOSED REBARS	REPAIR SPALLS PER GENERAL NOTES
RB-B-62	OVERHANG CRACKS	REPAIR CRACKS PER GENERAL NOTES
RB-B-63	OVERHANG SPALL	REPAIR SPALLS PER GENERAL NOTES
RB-B-64	DECK EFFLORESCENCE	CLEAN CONCRETE SURFACE
RB-B-65	ANCHOR BOLTS AND ANGLE CORROSION	BEAD BLAST STEEL AND TOUCH UP WITH TNEC ZINC RICH PAINT

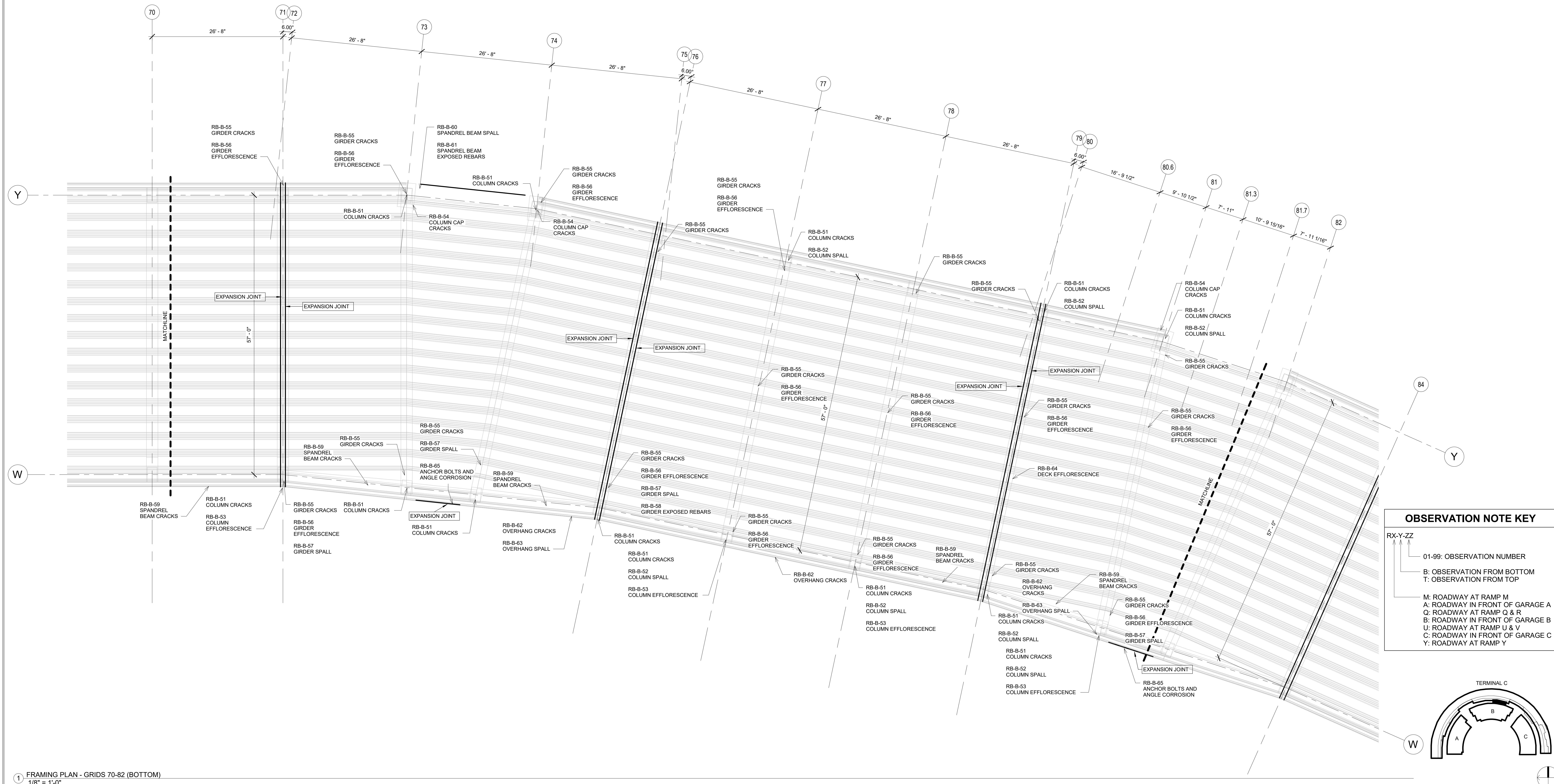

OBSERVATION NOTE KEY

RX-Y-ZZ

01-99: OBSERVATION NUMBER

B: OBSERVATION FROM BOTTOM

T: OBSERVATION FROM TOP

M: ROADWAY AT RAMP M

A: ROADWAY IN FRONT OF GARAGE A

Q: ROADWAY AT RAMP Q & R

B: ROADWAY IN FRONT OF GARAGE B

U: ROADWAY AT RAMP U & V

C: ROADWAY IN FRONT OF GARAGE C

Y: ROADWAY AT RAMP Y

1 FRAMING PLAN - GRIDS 70-82 (BOTTOM)
1/8" = 1'-0"

DFW DALLAS FORT WORTH INTERNATIONAL AIRPORT

2330 N INTERNATIONAL PARKWAY
DFW AIRPORT, TX 75261



AG & E Structural Emgenuity

PROJECT # 21084.00000
15200 Addison Road, Suite 310
Addison, Texas 75001
Ph: 214.503.7802
www.agne.com
TX REG. NO. F-8459
1-214-722-6000

DRAWN BY: ADD/GY
APPROVED BY: KW
ISSUE DATE: 2022-07-28

NOT FOR BID OR CONSTRUCTION

NO.	DATE	DESCRIPTION
2021-10-23	30% DESIGN	
2022-01-09	30% DESIGN	
2022-03-01	100% DESIGN	
2022-07-28	100% ISSUED FOR PERMIT (IFP)	

DFW TERMINAL C GARAGE AND ROADWAY

ROADWAY FRAMING PLAN - GRIDS 70-82 (BOTTOM)

PROJECT NUMBER: TFD-007

PERMIT NUMBER: B22-0023

SHEET NUMBER

S-153-900R

SCALE(S) AS NOTED ON THIS SHEET ARE BASED ON A FULL SIZE 30 X 42 SHEET.

OBSERVATION NOTE	OBSERVED CONDITION	REPAIR NOTE
TYP	CONTRACTOR TO NOTIFY EOR AFTER THE PAVEMENT IS MILLED OFF FOR TOP SLAB SURFACE OBSERVATION	
RB-T-51	JOINT SEAL FAILURE	REPLACE JOINT SEAL ON ROADWAY AND WALKWAY PER GENERAL NOTES
RB-T-52	PAVEMENT CRACKS	AFTER SURFACE MILLED OFF, REPAIR CRACKS PER GENERAL NOTES AND RESURFACE PAVEMENT
RB-T-53	PAVEMENT WEAR	AFTER SURFACE MILLED OFF, REPAIR CRACKS PER GENERAL NOTES AND RESURFACE PAVEMENT
RB-T-54	DECK SPALL	REPAIR SPALLS PER GENERAL NOTES
RB-T-55	DECK EXPOSED REBARS	REPAIR SPALLS PER GENERAL NOTES
RB-T-56	RAILING PARAPET WALL SPALL	REPAIR SPALLS PER GENERAL NOTES

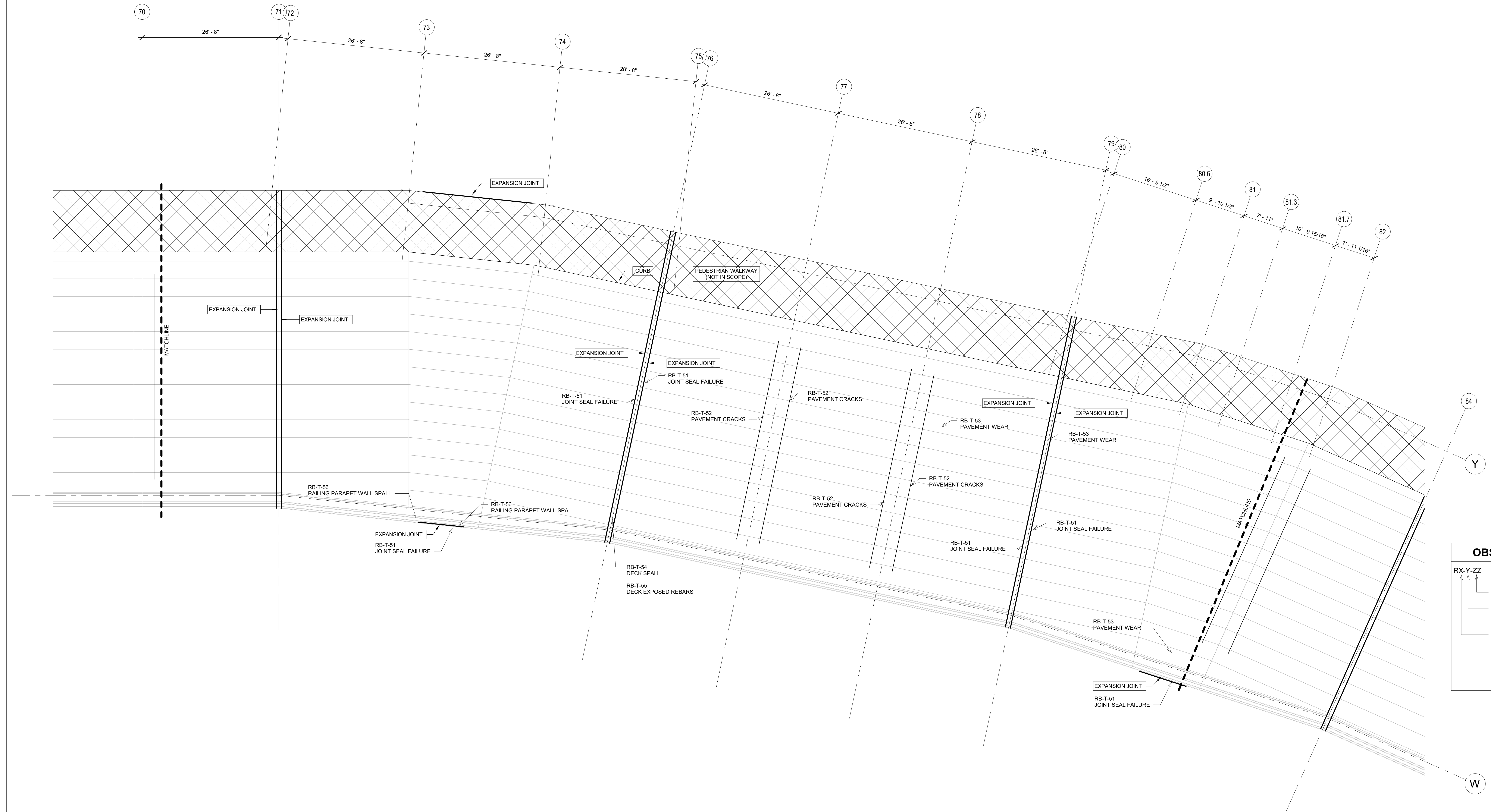

OBSERVATION NOTE KEY

RX-Y-ZZ
 01-99: OBSERVATION NUMBER
 B: OBSERVATION FROM BOTTOM
 T: OBSERVATION FROM TOP
 M: ROADWAY AT RAMP M
 A: ROADWAY IN FRONT OF GARAGE A
 Q: ROADWAY AT RAMP Q & R
 B: ROADWAY IN FRONT OF GARAGE B
 U: ROADWAY AT RAMP U & V
 C: ROADWAY IN FRONT OF GARAGE C
 Y: ROADWAY AT RAMP Y

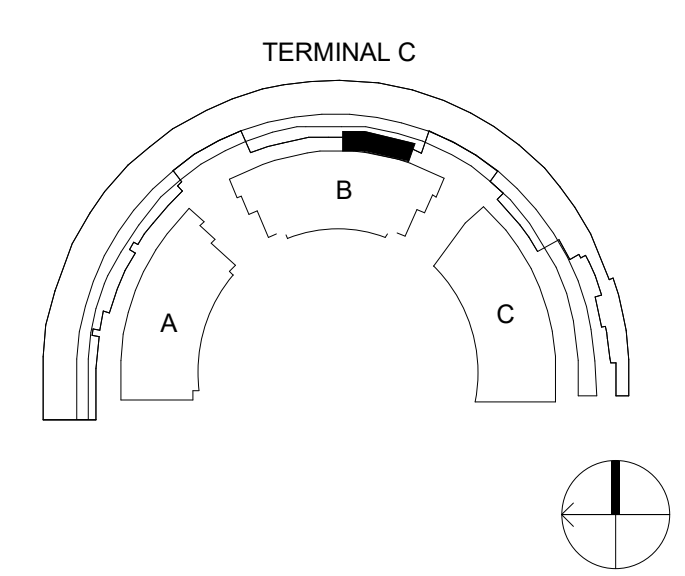

1 FRAMING PLAN - GRIDS 70-82 (TOP)
1/8" = 1'-0"

DFW DALLAS FORT WORTH INTERNATIONAL AIRPORT

2330 N INTERNATIONAL PARKWAY
DFW AIRPORT, TX 75261



AG & E Structural Integrity

PROJECT # 21084.00000
15200 Addison Road, Suite 310
Addison, Texas 75001
Ph: 214.503.7802
www.agie.com
TX REG. NO. F-8439
1-214-722-6000

DRAWN BY: ADD/GY
APPROVED BY: KW
ISSUE DATE: 2022-07-28

NOT FOR BID OR CONSTRUCTION

NO.	DATE	DESCRIPTION
2022-01-09	75% DESIGN	
2022-03-01	100% DESIGN	
2022-07-28	100% ISSUED FOR PERMIT (IFP)	

DFW TERMINAL C GARAGE AND ROADWAY

ROADWAY FRAMING PLAN - GRIDS 70-82 (TOP)

PROJECT NUMBER: TFD-007

PERMIT NUMBER: B22-0023

SHEET NUMBER

S-154-900R

SCALE(S) AS NOTED ON THIS SHEET ARE BASED ON A FULL SIZE 30 X 42 SHEET.

OBSERVATION NOTE	OBSERVED CONDITION	REPAIR NOTE
TYP	CONTRACTOR TO NOTIFY EOR AFTER THE PAVEMENT IS MILLED OFF FOR TOP SLAB SURFACE OBSERVATION	
RB-T-76	JOINT SEAL FAILURE	REPLACE JOINT SEAL ON ROADWAY AND WALKWAY PER GENERAL NOTES
RB-T-77	PAVEMENT CRACKS	AFTER SURFACE MILLED OFF, REPAIR CRACKS PER GENERAL NOTES AND RESURFACE PAVEMENT
RB-T-78	PAVEMENT WEAR	AFTER SURFACE MILLED OFF, REPAIR CRACKS PER GENERAL NOTES AND RESURFACE PAVEMENT
RB-T-79	RAILING PARAPET WALL CRACKS	REPAIR CRACKS PER GENERAL NOTES
RU-T-01	JOINT SEAL FAILURE	REPLACE JOINT SEAL ON ROADWAY AND WALKWAY PER GENERAL NOTES
RU-T-02	PAVEMENT CRACKS	AFTER SURFACE MILLED OFF, REPAIR CRACKS PER GENERAL NOTES AND RESURFACE PAVEMENT
RU-T-03	PAVEMENT WEAR	AFTER SURFACE MILLED OFF, REPAIR CRACKS PER GENERAL NOTES AND RESURFACE PAVEMENT
RU-T-04	RAILING PARAPET WALL CRACKS	REPAIR CRACKS PER GENERAL NOTES
RU-T-05	RAILING PARAPET WALL SPALL	REPAIR SPALLS PER GENERAL NOTES
RU-T-06	RAILING PARAPET WALL EXPOSED REBARS	REPAIR SPALLS PER GENERAL NOTES
RU-T-07	DIFFERENTIAL SLAB ELEVATIONS	LEVEL SLAB WITH TOPPING MORTAR PER GENERAL NOTES AND RESURFACE PAVEMENT
RU-T-08	DECK SPALL	REPAIR SPALLS PER GENERAL NOTES
RU-T-09	DECK CRACKS	REPAIR CRACKS PER GENERAL NOTES

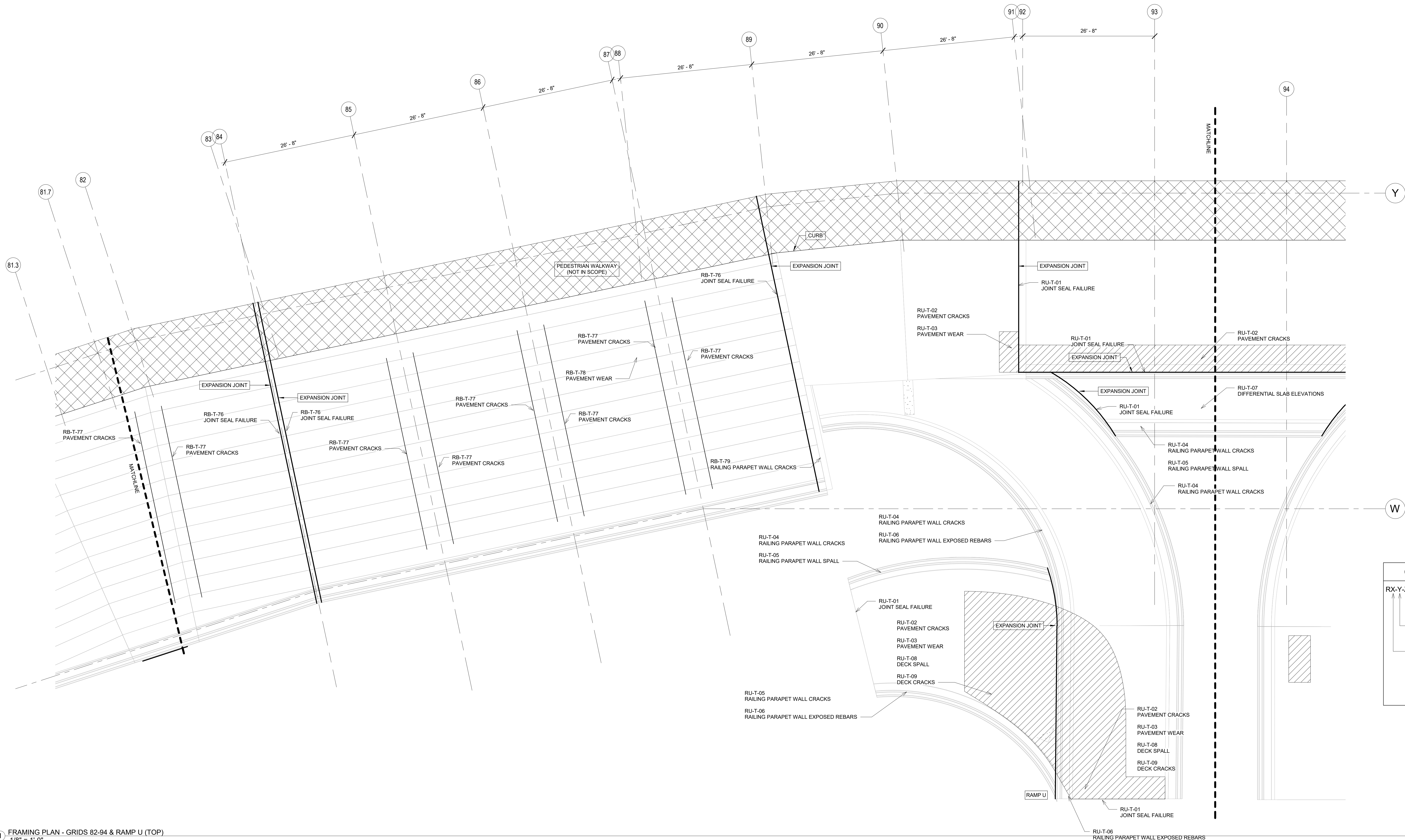

OBSERVATION NOTE KEY

RX-Y-ZZ
 01-99: OBSERVATION NUMBER
 B: OBSERVATION FROM BOTTOM
 T: OBSERVATION FROM TOP
 M: ROADWAY AT RAMP M
 A: ROADWAY IN FRONT OF GARAGE A
 Q: ROADWAY AT RAMP Q & R
 B: ROADWAY IN FRONT OF GARAGE B
 U: ROADWAY AT RAMP U & V
 C: ROADWAY IN FRONT OF GARAGE C
 Y: ROADWAY AT RAMP Y

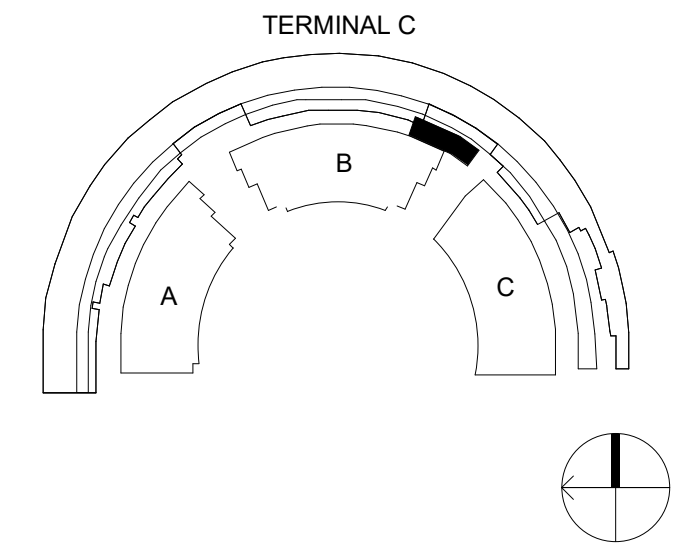

1 FRAMING PLAN - GRIDS 82-94 & RAMP U (TOP)
1/8" = 1'-0"



2330 N INTERNATIONAL PARKWAY
DFW AIRPORT, TX 75261

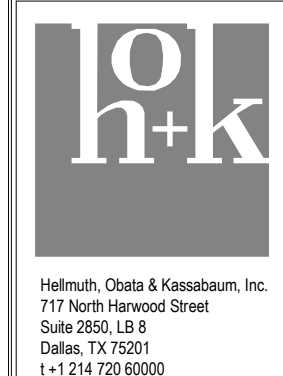
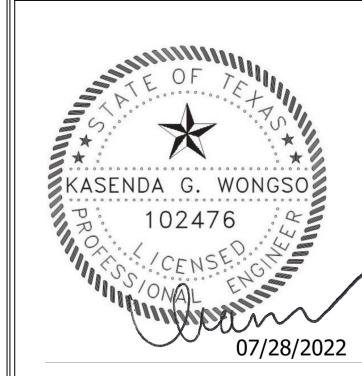

PROJECT # 21084.00000
15200 Addison Road, Suite 310
Addison, Texas 75001
Ph: 214.503.7802
www.agen.com
TX REG. NO. F-8439
1+214.722.6000

DRAWN BY: ADD/GY
APPROVED BY: KW
ISSUE DATE: 2022-07-28

NOT FOR BID OR CONSTRUCTION

NO.	DATE	DESCRIPTION
2022-01-09	37% DESIGN	
2022-03-01	100% DESIGN	
2022-07-28	100% ISSUED FOR PERMIT (IFP)	

DFW TERMINAL C GARAGE AND ROADWAY
ROADWAY FRAMING PLAN - GRIDS 82-94 & RAMP U (TOP)
PROJECT NUMBER: TFD-007
PERMIT NUMBER: B22-0023

SHEET NUMBER
S-156-900R

SCALE(S) AS NOTED ON THIS SHEET ARE BASED ON A FULL SIZE 30 X 42 SHEET.

OBSERVATION NOTE	OBSERVED CONDITION	REPAIR NOTE
RU-B-26	COLUMN CRACKS	REPAIR CRACKS PER GENERAL NOTES
RU-B-27	COLUMN SPALL	REPAIR SPALLS PER GENERAL NOTES
RU-B-28	GIRDER CRACKS	REPAIR CRACKS PER GENERAL NOTES
RU-B-29	GIRDER SPALL	REPAIR SPALLS PER GENERAL NOTES
RU-B-30	GIRDER EXPOSED REBARS	REPAIR SPALLS PER GENERAL NOTES
RU-B-31	GIRDER EFFLORESCENCE	CLEAN CONCRETE SURFACE
RU-B-32	DECK CRACKS	REPAIR CRACKS PER GENERAL NOTES
RU-B-33	DECK SPALL	REPAIR SPALLS PER GENERAL NOTES
RU-B-34	DECK EFFLORESCENCE	CLEAN CONCRETE SURFACE
RC-B-01	COLUMN CRACKS	REPAIR CRACKS PER GENERAL NOTES
RC-B-02	COLUMN SPALL	REPAIR SPALLS PER GENERAL NOTES
RC-B-03	COLUMN EFFLORESCENCE	CLEAN CONCRETE SURFACE
RC-B-04	GIRDER CRACKS	REPAIR CRACKS PER GENERAL NOTES
RC-B-05	GIRDER EFFLORESCENCE	CLEAN CONCRETE SURFACE
RC-B-06	GIRDER SPALL	REPAIR SPALLS PER GENERAL NOTES
RC-B-07	GIRDER EXPOSED REBARS	REPAIR SPALLS PER GENERAL NOTES
RC-B-08	SPANDREL BEAM CRACKS	REPAIR CRACKS PER GENERAL NOTES
RC-B-09	SPANDREL BEAM SPALL	REPAIR SPALLS PER GENERAL NOTES
RC-B-10	SPANDREL BEAM EXPOSED REBARS	REPAIR SPALLS PER GENERAL NOTES
RC-B-11	SPANDREL BEAM EFFLORESCENCE	CLEAN CONCRETE SURFACE
RC-B-12	OVERHANG CRACKS	REPAIR CRACKS PER GENERAL NOTES
RC-B-13	OVERHANG SPALL	REPAIR SPALLS PER GENERAL NOTES
RC-B-14	OVERHANG EFFLORESCENCE	CLEAN CONCRETE SURFACE
RC-B-15	DECK CRACKS	REPAIR CRACKS PER GENERAL NOTES

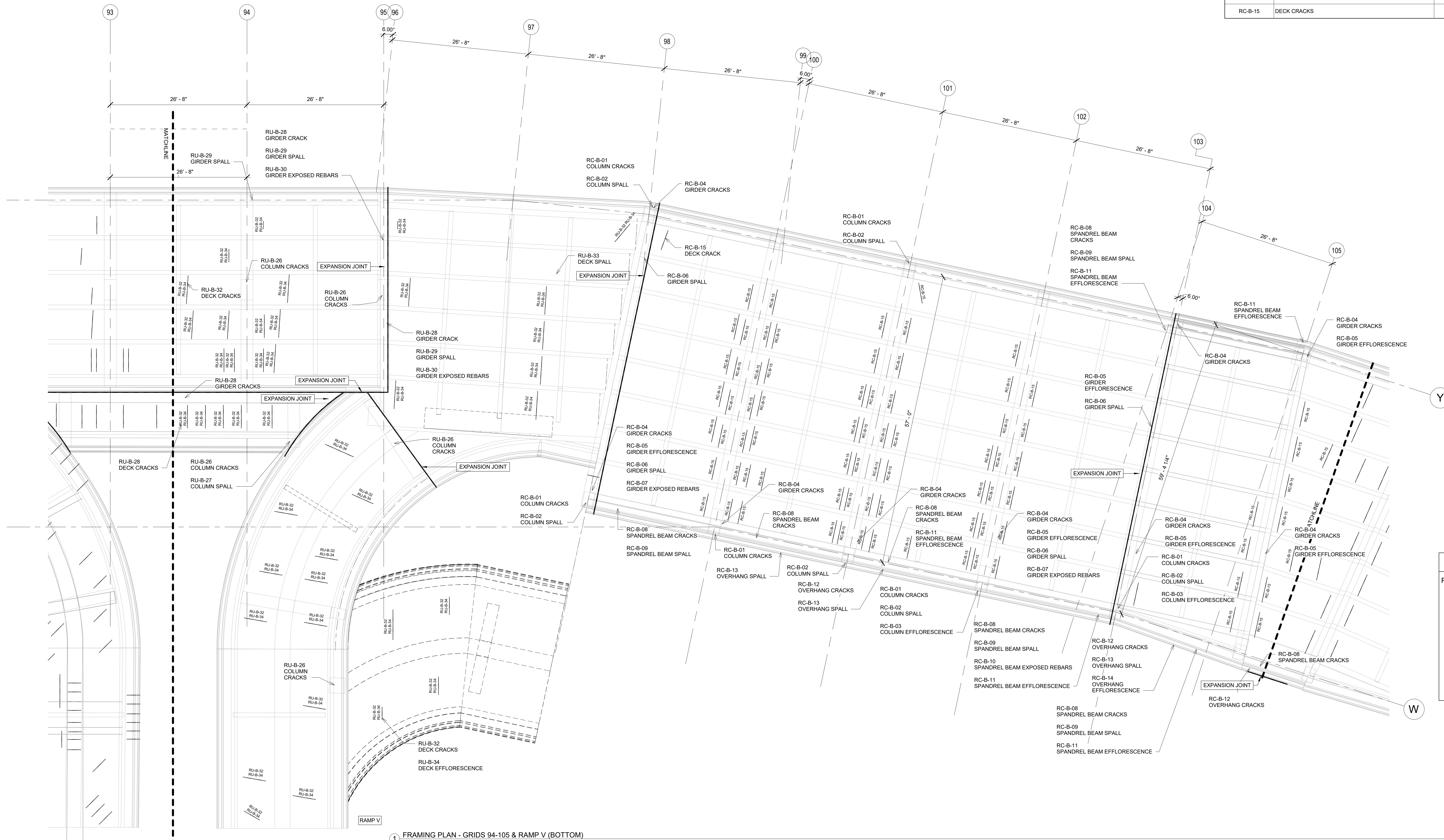

OBSERVATION NOTE KEY

RX-Y-ZZ
 01-99: OBSERVATION NUMBER
 B: OBSERVATION FROM BOTTOM
 T: OBSERVATION FROM TOP

M: ROADWAY AT RAMP M
 A: ROADWAY IN FRONT OF GARAGE A
 Q: ROADWAY AT RAMP Q & R
 B: ROADWAY IN FRONT OF GARAGE B
 U: ROADWAY AT RAMP U & V
 C: ROADWAY IN FRONT OF GARAGE C
 Y: ROADWAY AT RAMP Y

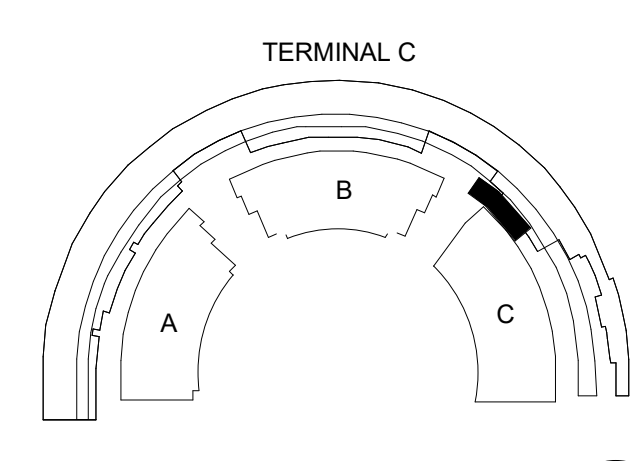

1 FRAMING PLAN - GRIDS 94-105 & RAMP V (BOTTOM)
 1/8" = 1'-0"



2330 N INTERNATIONAL PARKWAY
 DFW AIRPORT, TX 75261

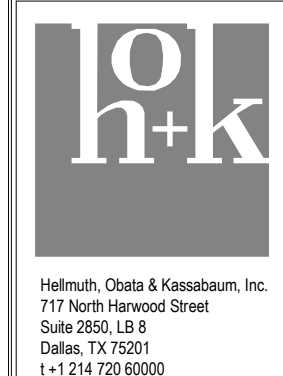
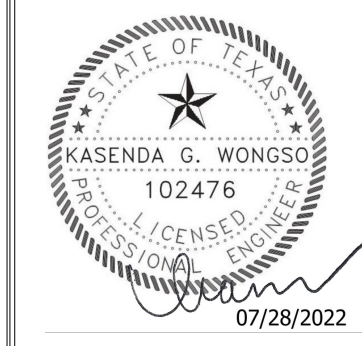

PROJECT # 21084.00000
 15200 Addison Road, Suite 310
 Addison, Texas 75001
 Ph: 214.503.7802
 www.agne.com
 TX REG. NO. F-8429
 1-214-722-6000

DRAWN BY: ADD/GY
 APPROVED BY: KW
 ISSUE DATE: 2022-07-28

NOT FOR BID OR CONSTRUCTION

NO.	DATE	DESCRIPTION
2021-10-23	30% DESIGN	
2022-01-09	70% DESIGN	
2022-03-01	100% DESIGN	
2022-07-28	100% ISSUED FOR PERMIT (IFP)	

DFW TERMINAL C GARAGE AND ROADWAY
ROADWAY FRAMING PLAN - GRIDS 94-105 & RAMP V (BOTTOM)

PROJECT NUMBER: TFD-007

PERMIT NUMBER: 822-0023

SHEET NUMBER
S-157-900R

SCALE(S) AS NOTED ON THIS SHEET ARE BASED ON A FULL SIZE 30 X 42 SHEET.

OBSERVATION NOTE	OBSERVED CONDITION	REPAIR NOTE
TYP	CONTRACTOR TO NOTIFY EOR AFTER THE PAVEMENT IS MILLED OFF FOR TOP SLAB SURFACE OBSERVATION	
RU-T-26	JOINT SEAL FAILURE	REPLACE JOINT SEAL ON ROADWAY AND WALKWAY PER GENERAL NOTES
RU-T-27	PAVEMENT CRACKS	AFTER SURFACE MILLED OFF, REPAIR CRACKS PER GENERAL NOTES AND RESURFACE PAVEMENT
RU-T-28	PAVEMENT WEAR	AFTER SURFACE MILLED OFF, REPAIR CRACKS PER GENERAL NOTES AND RESURFACE PAVEMENT
RU-T-29	DECK SPALL	REPAIR SPALLS PER GENERAL NOTES
RU-T-30	RAILING PARAPET WALL CRACKS	REPAIR CRACKS PER GENERAL NOTES
RU-T-31	RAILING PARAPET WALL SPALL	REPAIR SPALLS PER GENERAL NOTES
RU-T-32	RAILING CORROSION	BEAD BLAST STEEL AND REPAINT
RU-T-33	RAILING DAMAGE	COVER OPENING WITH 1/4-INCH STEEL PLATE AND PAINT
RC-T-01	JOINT SEAL FAILURE	REPLACE JOINT SEAL ON ROADWAY AND WALKWAY PER GENERAL NOTES
RC-T-02	PAVEMENT CRACKS	AFTER SURFACE MILLED OFF, REPAIR CRACKS PER GENERAL NOTES AND RESURFACE PAVEMENT
RC-T-03	PAVEMENT WEAR	AFTER SURFACE MILLED OFF, REPAIR CRACKS PER GENERAL NOTES AND RESURFACE PAVEMENT
RC-T-04	DECK SPALL	REPAIR SPALLS PER GENERAL NOTES
RC-T-05	RAILING PARAPET WALL CRACKS	REPAIR CRACKS PER GENERAL NOTES
RC-T-06	RAILING PARAPET WALL SPALL	REPAIR SPALLS PER GENERAL NOTES
RC-T-07	RAILING PARAPET WALL EXPOSED REBARS	REPAIR SPALLS PER GENERAL NOTES

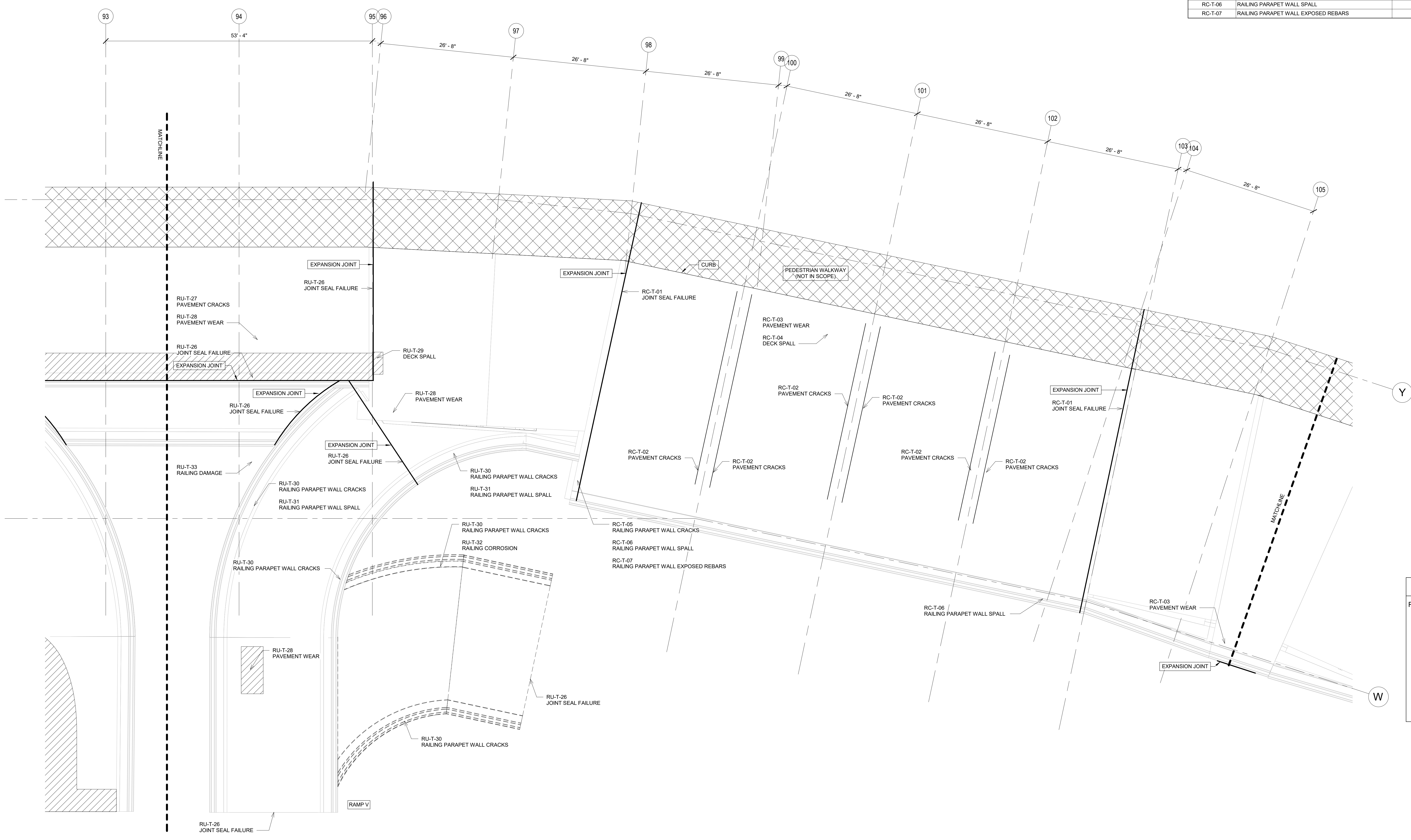

OBSERVATION NOTE KEY

RX-Y-ZZ
 01-99: OBSERVATION NUMBER
 B: OBSERVATION FROM BOTTOM
 T: OBSERVATION FROM TOP

M: ROADWAY AT RAMP M
 A: ROADWAY IN FRONT OF GARAGE A
 Q: ROADWAY AT RAMP Q & R
 B: ROADWAY IN FRONT OF GARAGE B
 U: ROADWAY AT RAMP U & V
 C: ROADWAY IN FRONT OF GARAGE C
 Y: ROADWAY AT RAMP Y

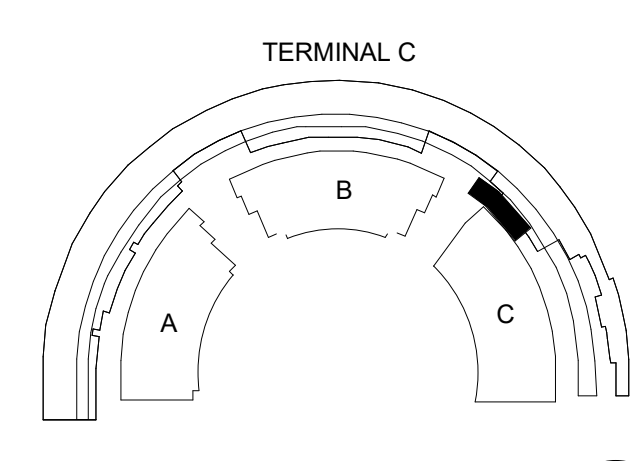

1 FRAMING PLAN - GRIDS 94-105 & RAMP V (TOP)
 1/8" = 1'-0"

DFW DALLAS FORT WORTH INTERNATIONAL AIRPORT

2330 N INTERNATIONAL PARKWAY
 DFW AIRPORT, TX 75261



h+k Heintz, Clark & Koenigsmann, Inc.
 717 North Harvard Street
 Suite 2050, LB #
 Dallas, TX 75201
 1-214-722-6000

AG & E PROJECT # 21084.00000
 15200 Addison Road, Suite 310
 Addison, Texas 75001
 Ph: 214-420-7202
 www.agne.com
 TX REG. NO. F-8429
 Structural Integrity

DRAWN BY: ADD/GY
 APPROVED BY: KW
 ISSUE DATE: 2022-07-28

NOT FOR BID OR CONSTRUCTION

NO.	DATE	DESCRIPTION
2022-01-09	75% DESIGN	
2022-03-01	100% DESIGN	
2022-07-28	100% ISSUED FOR PERMIT (IFP)	

DFW TERMINAL C GARAGE AND ROADWAY

ROADWAY FRAMING PLAN - GRIDS 94-105 & RAMP V (TOP)

PROJECT NUMBER: TFD-007

PERMIT NUMBER: 822-0023

SHEET NUMBER
S-158-900R

SCALE(S) AS NOTED ON THIS SHEET ARE BASED ON A FULL SIZE 30 X 42 SHEET.

OBSERVATION NOTE	OBSERVED CONDITION	REPAIR NOTE
RC-B-26	COLUMN CRACKS	REPAIR CRACKS PER GENERAL NOTES
RC-B-27	COLUMN SPALL	REPAIR SPALLS PER GENERAL NOTES
RC-B-28	COLUMN EXPOSED REBARS	REPAIR SPALLS PER GENERAL NOTES
RC-B-29	COLUMN EFFLORESCENCE	CLEAN CONCRETE SURFACE
RC-B-30	GIRDER CRACKS	REPAIR CRACKS PER GENERAL NOTES
RC-B-31	GIRDER SPALL	REPAIR SPALLS PER GENERAL NOTES
RC-B-32	GIRDER EFFLORESCENCE	CLEAN CONCRETE SURFACE
RC-B-33	GIRDER EXPOSED REBARS	REPAIR SPALLS PER GENERAL NOTES
RC-B-34	SPANDREL BEAM CRACKS	REPAIR CRACKS PER GENERAL NOTES
RC-B-35	SPANDREL BEAM SPALL	REPAIR SPALLS PER GENERAL NOTES
RC-B-36	SPANDREL BEAM EFFLORESCENCE	CLEAN CONCRETE SURFACE
RC-B-37	OVERHANG CRACKS	REPAIR CRACKS PER GENERAL NOTES
RC-B-38	OVERHANG SPALL	REPAIR SPALLS PER GENERAL NOTES
RC-B-39	OVERHANG EFFLORESCENCE	CLEAN CONCRETE SURFACE
RC-B-40	DECK CRACKS	REPAIR CRACKS PER GENERAL NOTES
RC-B-41	DECK SPALL	REPAIR SPALLS PER GENERAL NOTES
RC-B-42	DECK EXPOSED REBARS	REPAIR SPALLS PER GENERAL NOTES
RC-B-43	DECK EFFLORESCENCE	CLEAN CONCRETE SURFACE

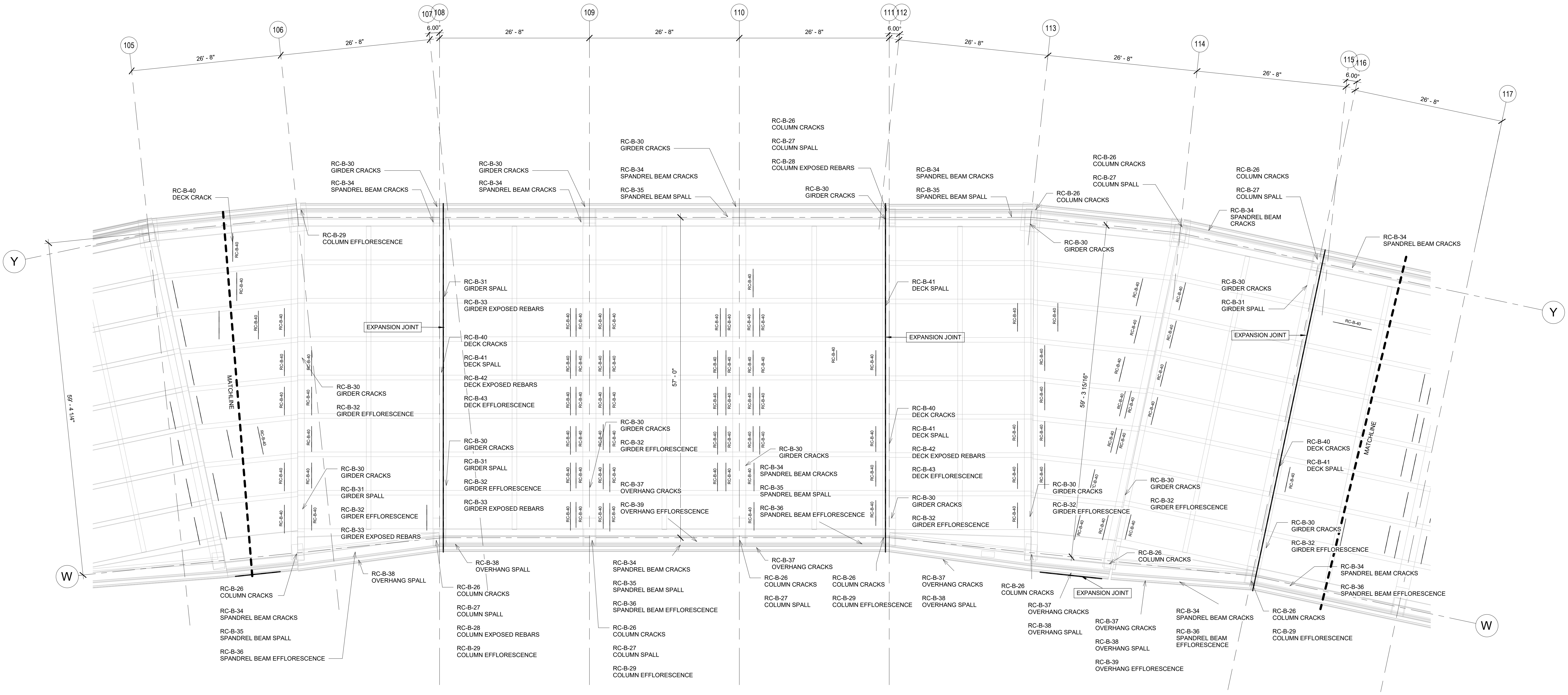

OBSERVATION NOTE KEY	
01-99:	OBSERVATION NUMBER
B:	OBSERVATION FROM BOTTOM
T:	OBSERVATION FROM TOP
M:	ROADWAY AT RAMP M
A:	ROADWAY IN FRONT OF GARAGE A
Q:	ROADWAY AT RAMP Q & R
B:	ROADWAY IN FRONT OF GARAGE B
U:	ROADWAY AT RAMP U & V
C:	ROADWAY IN FRONT OF GARAGE C
Y:	ROADWAY AT RAMP Y

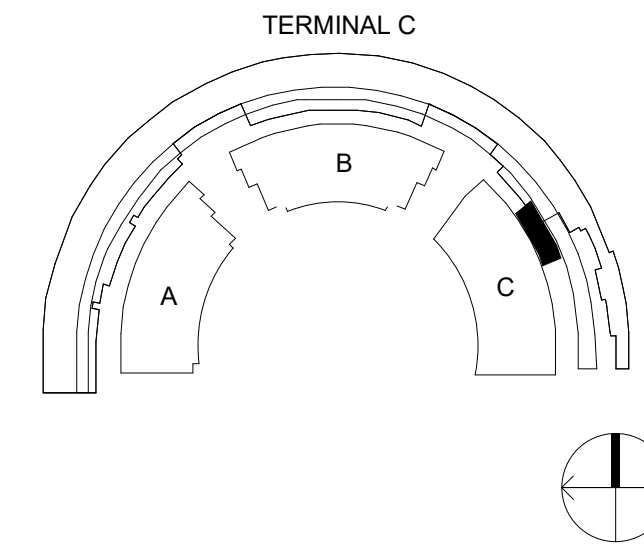

1 FRAMING PLAN - GRIDS 105-116 (BOTTOM)
1/8" = 1'-0"



2330 N INTERNATIONAL PARKWAY
DFW AIRPORT, TX 75261

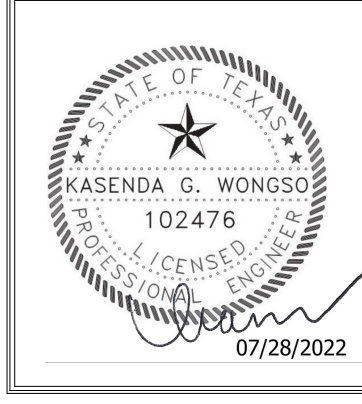

PROJECT # 21084.00000
15200 Addison Road, Suite 310
Addison, Texas 75001
Ph: 214 403 7802
www.agie.com
TX REG. NO. F-8439

NOT FOR BID OR CONSTRUCTION

NO.	DATE	DESCRIPTION
2021-10-23	30% DESIGN	
2022-01-09	70% DESIGN	
2022-03-01	100% DESIGN	
2022-07-28	100% ISSUED FOR PERMIT (IFP)	

DRAWN BY: ADD/GY
APPROVED BY: KW
ISSUE DATE: 2022-07-28

PROJECT NUMBER: TFD-007

DFW TERMINAL C GARAGE AND ROADWAY
ROADWAY FRAMING PLAN - GRIDS 105-116 (BOTTOM)

PERMIT NUMBER: B22-0023

SHEET NUMBER
S-159-900R

SCALE(S) AS NOTED ON THIS SHEET ARE BASED ON A FULL SIZE 30 X 42 SHEET.

OBSERVATION NOTE	OBSERVED CONDITION	REPAIR NOTE
TYP	CONTRACTOR TO NOTIFY EOR AFTER THE PAVEMENT IS MILLED OFF FOR TOP SLAB SURFACE OBSERVATION	
RC-T-26	JOINT SEAL FAILURE	REPLACE JOINT SEAL ON ROADWAY AND WALKWAY PER GENERAL NOTES
RC-T-27	PAVEMENT CRACKS	AFTER SURFACE MILLED OFF, REPAIR CRACKS PER GENERAL NOTES AND RESURFACE PAVEMENT
RC-T-28	RAILING PARAPET WALL CRACKS	REPAIR CRACKS PER GENERAL NOTES
RC-T-29	RAILING PARAPET WALL SPALL	REPAIR SPALLS PER GENERAL NOTES
RC-T-30	DAMAGED GRATING	BEND PLATE TO ORIGINAL SHAPE

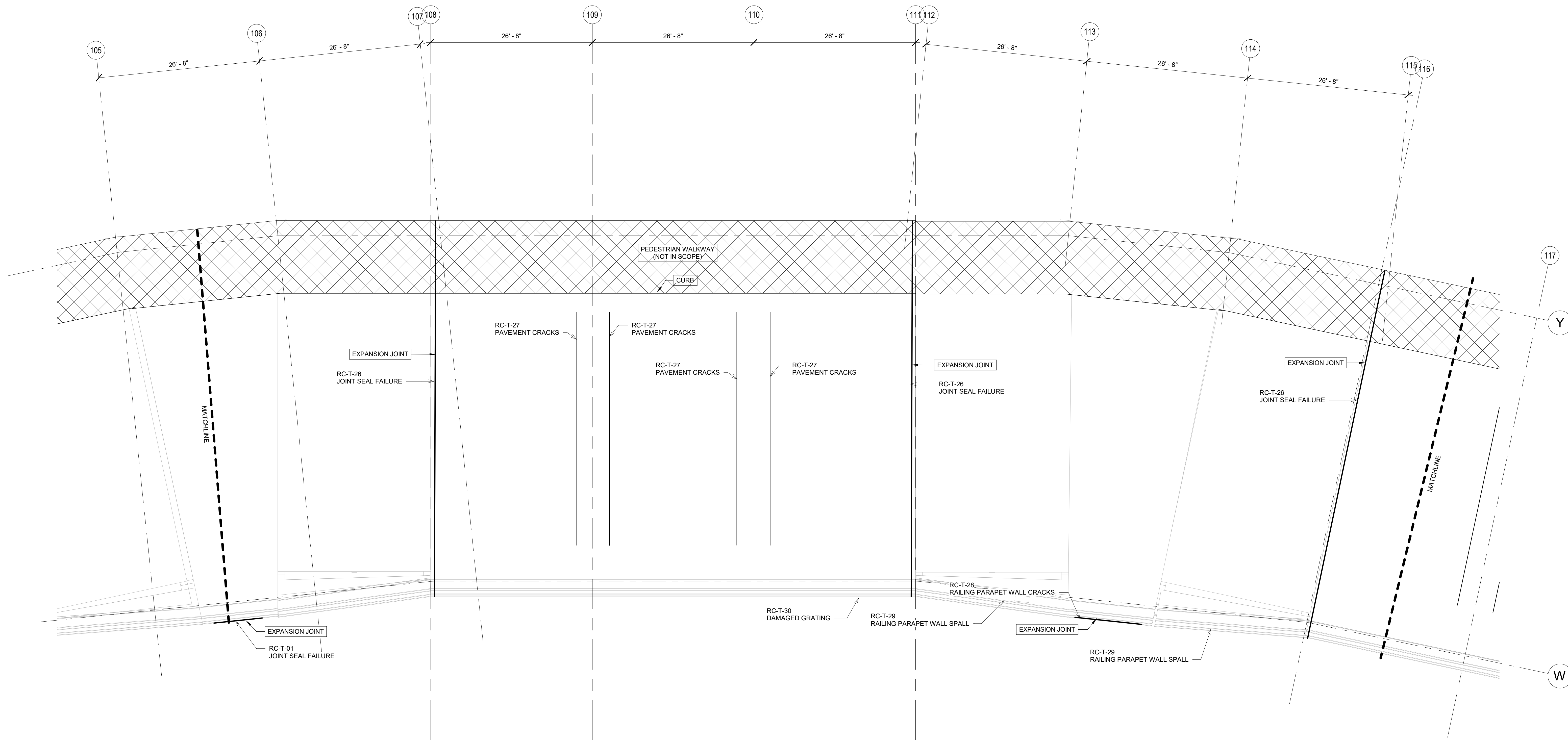

OBSERVATION NOTE KEY

RX-Y-ZZ
 01-99: OBSERVATION NUMBER
 B: OBSERVATION FROM BOTTOM
 T: OBSERVATION FROM TOP

M: ROADWAY AT RAMP M
 A: ROADWAY IN FRONT OF GARAGE A
 Q: ROADWAY AT RAMP Q & R
 B: ROADWAY IN FRONT OF GARAGE B
 U: ROADWAY AT RAMP U & V
 C: ROADWAY IN FRONT OF GARAGE C
 Y: ROADWAY AT RAMP Y

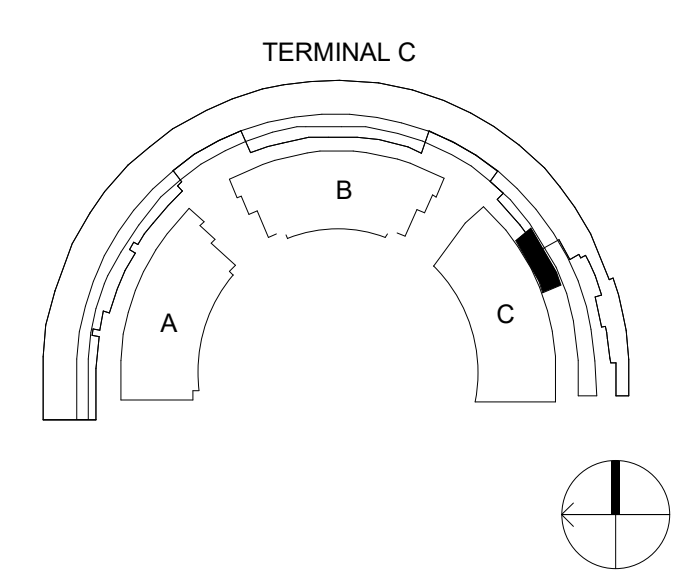

1 FRAMING PLAN - GRIDS 105-116 (TOP)
 1/8" = 1'-0"

DFW DALLAS FORT WORTH INTERNATIONAL AIRPORT

2330 N INTERNATIONAL PARKWAY
 DFW AIRPORT, TX 75261



h+k Heintz, Clark & Koenigsmann, Inc.
 717 North Harvard Street
 Suite 2050, LB #
 Dallas, TX 75201
 1-214-722-6000

AG & E PROJECT # 21084.00000
 15200 Addison Road, Suite 310
 Addison, Texas 75001
 Ph: 214-503-7802
 www.agne.com
 TX REG. NO. F-8439
 Structural Engenuity

DRAWN BY: ADD/GY
 APPROVED BY: KW
 ISSUE DATE: 2022-07-28

NOT FOR BID OR CONSTRUCTION

NO.	DATE	DESCRIPTION
2022-01-09	75% DESIGN	
2022-03-01	100% DESIGN	
2022-07-28	100% ISSUED FOR PERMIT (IFP)	

DFW TERMINAL C GARAGE AND ROADWAY

ROADWAY FRAMING PLAN - GRIDS 105-116 (TOP)

PROJECT NUMBER: TFD-007

PERMIT NUMBER: 822-0023

SHEET NUMBER
S-160-900R

SCALE(S) AS NOTED ON THIS SHEET ARE BASED ON A FULL SIZE 30 X 42 SHEET.

OBSERVATION NOTE	OBSERVED CONDITION	REPAIR NOTE
TYP	CONTRACTOR TO NOTIFY EOR AFTER THE PAVEMENT IS MILLED OFF FOR TOP SLAB SURFACE OBSERVATION	
RC-T-51	JOINT SEAL FAILURE	REPLACE JOINT SEAL ON ROADWAY AND WALKWAY PER GENERAL NOTES
RC-T-52	PAVEMENT CRACKS	AFTER SURFACE MILLED OFF, REPAIR CRACKS PER GENERAL NOTES AND RESURFACE PAVEMENT
RC-T-53	RAILING CRACK	WELD AROUND STEEL TUBE AND PAINT
RC-T-54	RAILING CORROSION	BEAD BLAST STEEL AND REPAINT
RC-T-55	GAP BETWEEN CONCRETE	INSTALL JOINT SEAL PER GENERAL NOTES

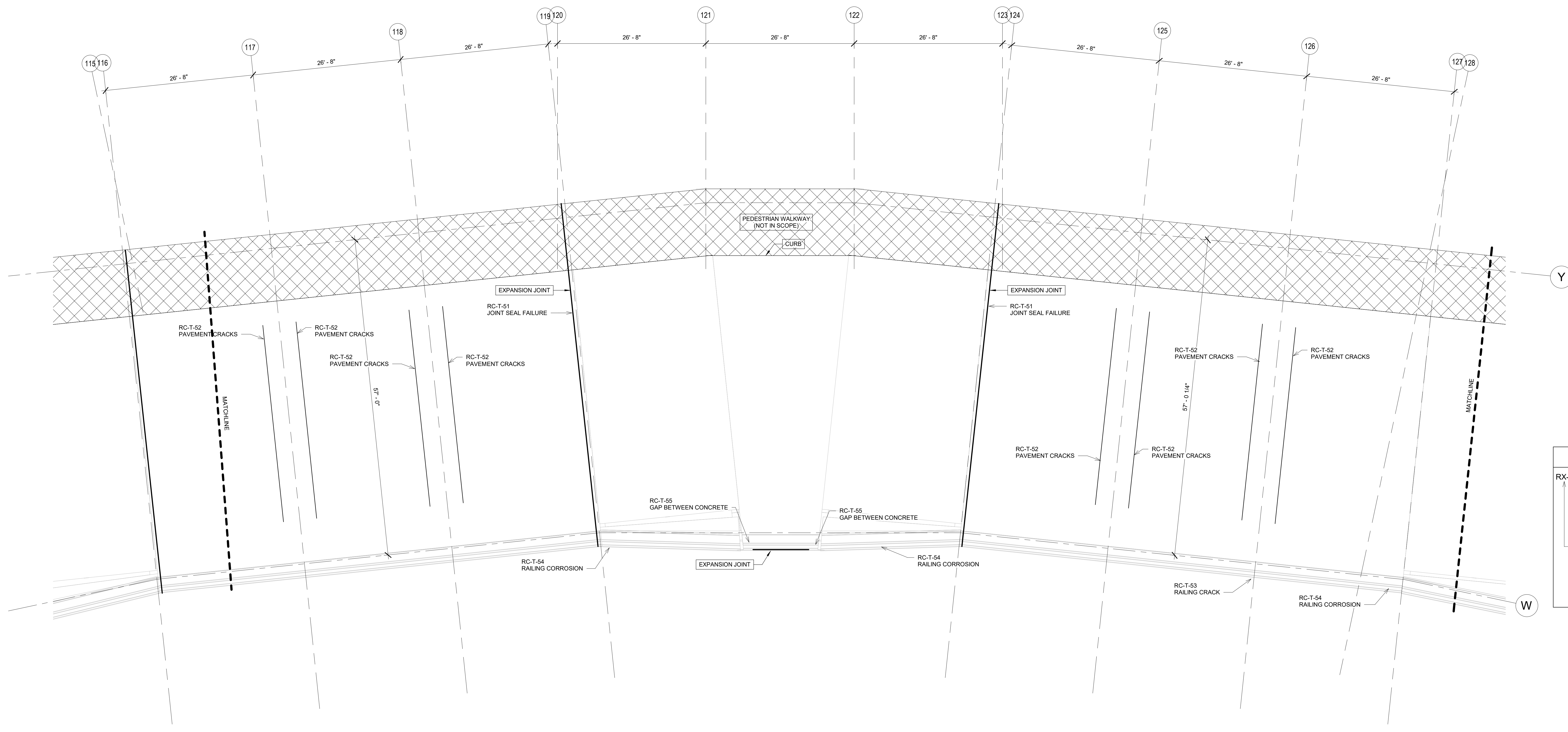

OBSERVATION NOTE KEY	
RX-Y-ZZ	01-99: OBSERVATION NUMBER
B:	OBSERVATION FROM BOTTOM
T:	OBSERVATION FROM TOP
M:	ROADWAY AT RAMP M
A:	ROADWAY IN FRONT OF GARAGE A
Q:	ROADWAY AT RAMP Q & R
B:	ROADWAY IN FRONT OF GARAGE B
U:	ROADWAY AT RAMP U & V
C:	ROADWAY IN FRONT OF GARAGE C
Y:	ROADWAY AT RAMP Y

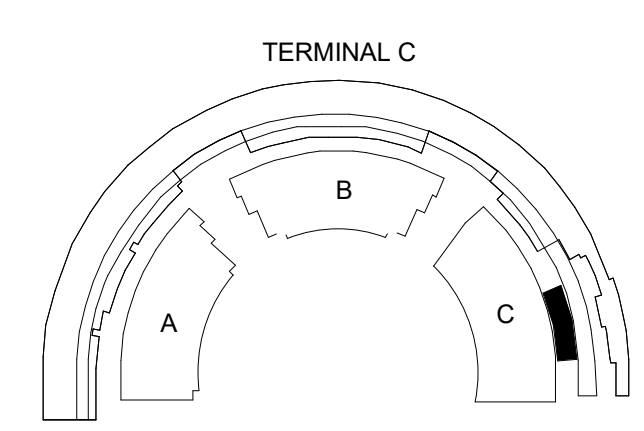

1 FRAMING PLAN - GRIDS 116-128 (TOP)
1/8" = 1'-0"



2330 N INTERNATIONAL PARKWAY
DFW AIRPORT, TX 75261

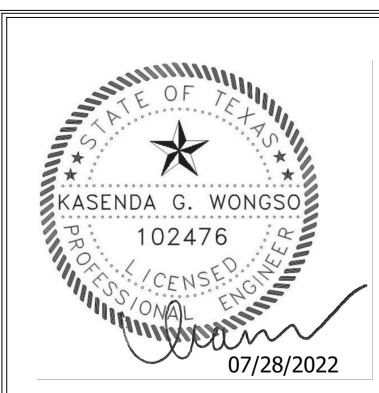

DRAWN BY: ADD/GY
APPROVED BY: KW
ISSUE DATE: 2022-07-28

NOT FOR BID OR CONSTRUCTION

NO.	DATE	DESCRIPTION
2022-01-09		30% DESIGN
2022-03-01		100% DESIGN
2022-07-28		100% ISSUED FOR PERMIT (IFP)

DFW TERMINAL C GARAGE AND ROADWAY
ROADWAY FRAMING PLAN - GRIDS 116-128 (TOP)

PROJECT NUMBER: TFD-007

PERMIT NUMBER: 822-0023

SHEET NUMBER
S-162-900R

SCALE(S) AS NOTED ON THIS SHEET ARE BASED ON A FULL SIZE 30 X 42 SHEET.

OBSERVATION NOTE	OBSERVED CONDITION	REPAIR NOTE
RC-B-76	COLUMN CRACKS	REPAIR CRACKS PER GENERAL NOTES
RC-B-77	COLUMN SPALL	REPAIR SPALLS PER GENERAL NOTES
RC-B-78	COLUMN EXPOSED REBARS	REPAIR SPALLS PER GENERAL NOTES
RC-B-79	COLUMN EFFLORESCENCE	CLEAN CONCRETE SURFACE
RC-B-80	GIRDER CRACKS	REPAIR CRACKS PER GENERAL NOTES
RC-B-81	GIRDER SPALL	REPAIR SPALLS PER GENERAL NOTES
RC-B-82	GIRDER EFFLORESCENCE	CLEAN CONCRETE SURFACE
RC-B-83	SPANDREL BEAM CRACKS	REPAIR CRACKS PER GENERAL NOTES
RC-B-84	SPANDREL BEAM SPALL	REPAIR SPALLS PER GENERAL NOTES
RC-B-85	SPANDREL BEAM EXPOSED REBARS	REPAIR SPALLS PER GENERAL NOTES
RC-B-86	SPANDREL BEAM EFFLORESCENCE	CLEAN CONCRETE SURFACE
RC-B-87	OVERHANG CRACKS	REPAIR CRACKS PER GENERAL NOTES
RC-B-88	OVERHANG SPALL	REPAIR SPALLS PER GENERAL NOTES
RC-B-89	OVERHANG EFFLORESCENCE	CLEAN CONCRETE SURFACE
RC-B-90	DECK CRACKS	REPAIR CRACKS PER GENERAL NOTES
RC-B-91	DECK SPALL	REPAIR SPALLS PER GENERAL NOTES
RY-B-01	COLUMN CRACKS	REPAIR CRACKS PER GENERAL NOTES
RY-B-02	COLUMN SPALL	REPAIR SPALLS PER GENERAL NOTES
RY-B-03	COLUMN EXPOSED REBARS	REPAIR SPALLS PER GENERAL NOTES
RY-B-04	GIRDER CRACKS	REPAIR CRACKS PER GENERAL NOTES
RY-B-05	GIRDER SPALL	REPAIR SPALLS PER GENERAL NOTES
RY-B-06	OVERHANG CRACKS	REPAIR CRACKS PER GENERAL NOTES
RY-B-07	OVERHANG SPALL	REPAIR SPALLS PER GENERAL NOTES
RY-B-08	OVERHANG EFFLORESCENCE	CLEAN CONCRETE SURFACE
RY-B-09	DECK CRACKS	REPAIR CRACKS PER GENERAL NOTES
RY-B-10	DECK EFFLORESCENCE	CLEAN CONCRETE SURFACE

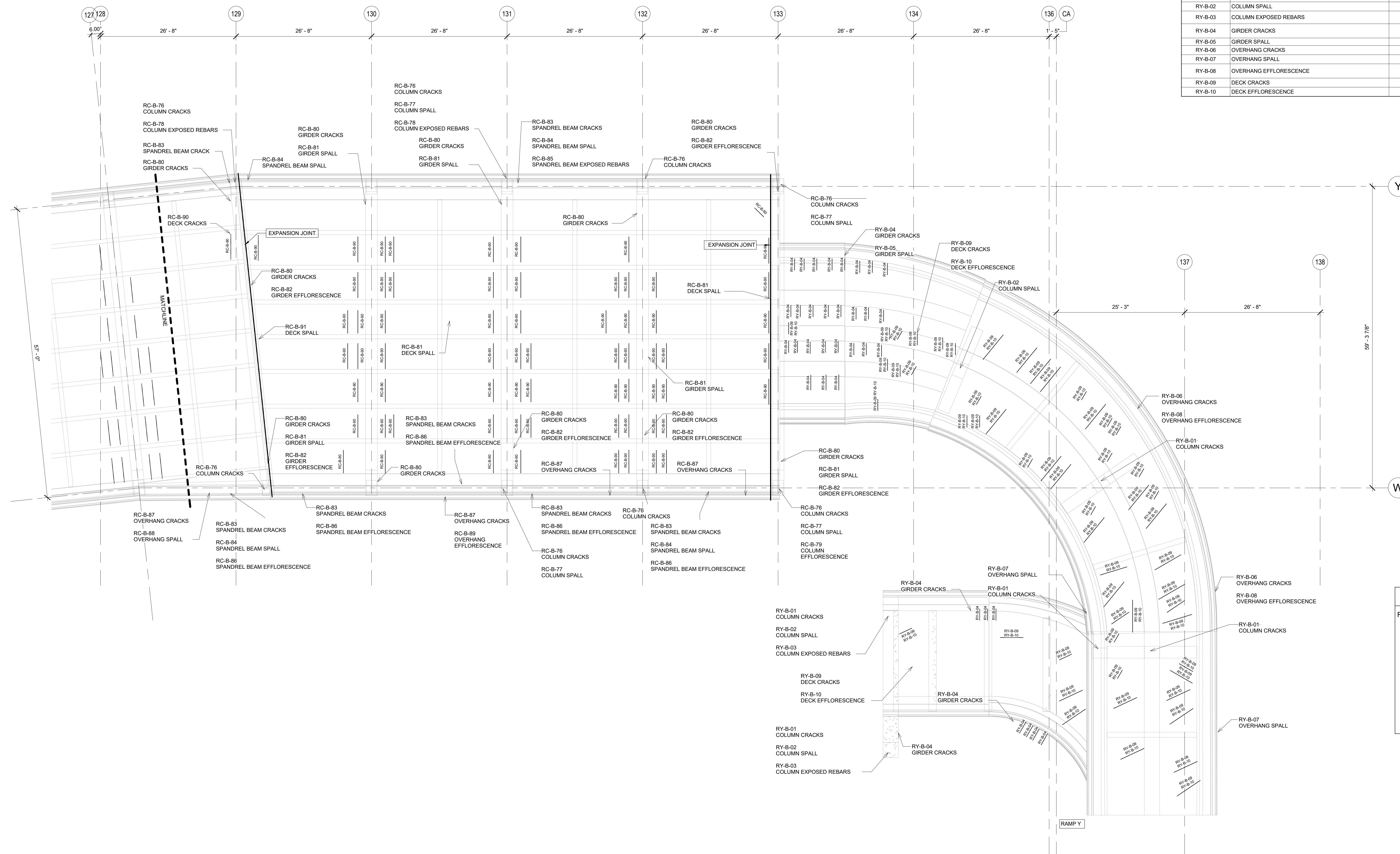

OBSERVATION NOTE KEY

RX-Y-ZZ
 01-99: OBSERVATION NUMBER
 B: OBSERVATION FROM BOTTOM
 T: OBSERVATION FROM TOP
 M: ROADWAY AT RAMP M
 A: ROADWAY IN FRONT OF GARAGE A
 Q: ROADWAY AT RAMP Q & R
 B: ROADWAY IN FRONT OF GARAGE B
 U: ROADWAY AT RAMP U & V
 C: ROADWAY IN FRONT OF GARAGE C
 Y: ROADWAY AT RAMP Y

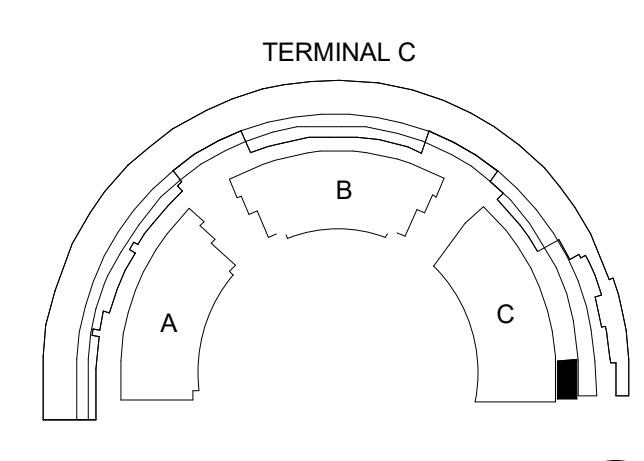

1 FRAMING PLAN - GRIDS 128-133 & RAMP Y (BOTTOM)
1/8" = 1'-0"

DFW DALLAS FORT WORTH INTERNATIONAL AIRPORT

2330 N INTERNATIONAL PARKWAY
DFW AIRPORT, TX 75261



AG & E PROJECT # 21084.00000
15200 Addison Road, Suite 310
Addison, Texas 75001
PH: 214-503-7802
www.agenet.com
TX REG. NO. F-8439
Structural Integrity

DRAWN BY: ADD/GY
APPROVED BY: KW
ISSUE DATE: 2022-07-28

NOT FOR BID OR CONSTRUCTION

NO.	DATE	DESCRIPTION
2021-10-23	30% DESIGN	
2022-01-09	70% DESIGN	
2022-03-01	100% DESIGN	
2022-07-28	100% ISSUED FOR PERMIT (IFP)	

DFW TERMINAL C GARAGE AND ROADWAY

ROADWAY FRAMING PLAN - GRIDS 128-133 & RAMP Y (BOTTOM)

PROJECT NUMBER: TFD-007

PERMIT NUMBER: B22-0023

SHEET NUMBER

S-163-900R

SCALE(S) AS NOTED ON THIS SHEET ARE BASED ON A FULL SIZE 30 X 42 SHEET.

OBSERVATION NOTE	OBSERVED CONDITION	REPAIR NOTE
TYP	CONTRACTOR TO NOTIFY EOR AFTER THE PAVEMENT IS MILLED OFF FOR TOP SLAB SURFACE OBSERVATION	
RC-T-76	JOINT SEAL FAILURE	REPLACE JOINT SEAL ON ROADWAY AND WALKWAY PER GENERAL...
RC-T-77	PAVEMENT CRACKS	AFTER SURFACE MILLED OFF, REPAIR CRACKS PER GENERAL NOTES AND RESURFACE PAVEMENT
RC-T-78	RAILING PARAPET WALL CRACKS	REPAIR CRACKS PER GENERAL NOTES
RC-T-79	RAILING CRACK	WELD AROUND STEEL TUBE AND PAINT
RC-T-80	RAILING CORROSION	BEAD BLAST STEEL AND REPAINT
RY-T-01	JOINT SEAL FAILURE	REPLACE JOINT SEAL ON ROADWAY AND WALKWAY PER GENERAL...
RY-T-02	PAVEMENT WEAR	AFTER SURFACE MILLED OFF, REPAIR CRACKS PER GENERAL NOTES AND RESURFACE PAVEMENT
RY-T-03	PAVEMENT CRACKS	AFTER SURFACE MILLED OFF, REPAIR CRACKS PER GENERAL NOTES AND RESURFACE PAVEMENT
RY-T-04	RAILING PARAPET WALL CRACKS	REPAIR CRACKS PER GENERAL NOTES
RY-T-05	RAILING PARAPET WALL SPALL	REPAIR SPALLS PER GENERAL NOTES
RY-T-06	RAILING PARAPET WALL EXPOSED REBARS	REPAIR SPALLS PER GENERAL NOTES
RY-T-07	RAILING CORROSION	BEAD BLAST STEEL AND REPAINT
RY-T-08	RAILING CONNECTION GAP	STRAIGHTEN STEEL TUBE WITH CUT AND WELD ALL AROUND

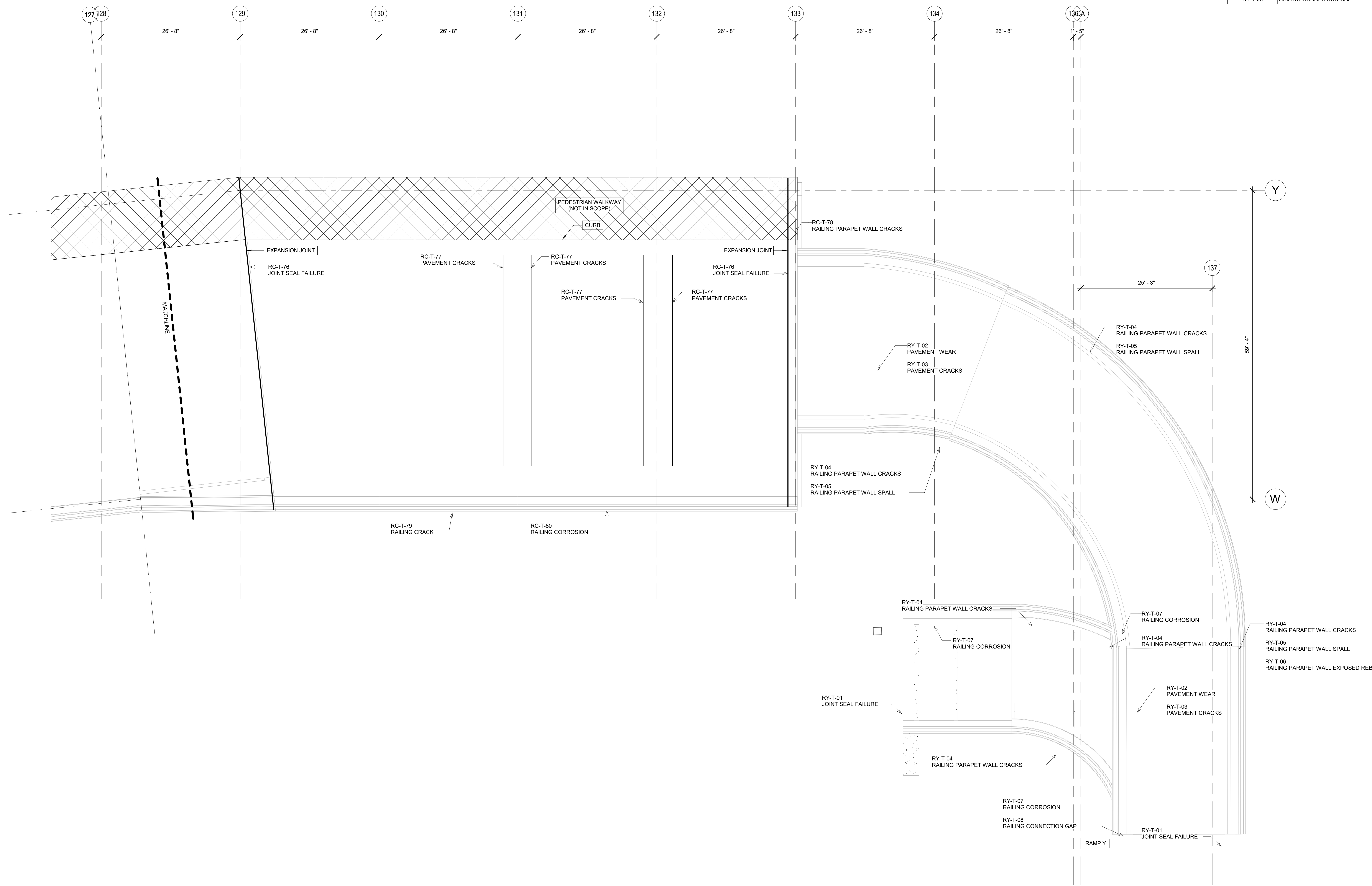

OBSERVATION NOTE KEY	
RX-Y-ZZ	01-99: OBSERVATION NUMBER
B:	OBSERVATION FROM BOTTOM
T:	OBSERVATION FROM TOP
M:	ROADWAY AT RAMP M
A:	ROADWAY IN FRONT OF GARAGE A
Q:	ROADWAY AT RAMP Q & R
B:	ROADWAY IN FRONT OF GARAGE B
U:	ROADWAY AT RAMP U & V
C:	ROADWAY IN FRONT OF GARAGE C
Y:	ROADWAY AT RAMP Y

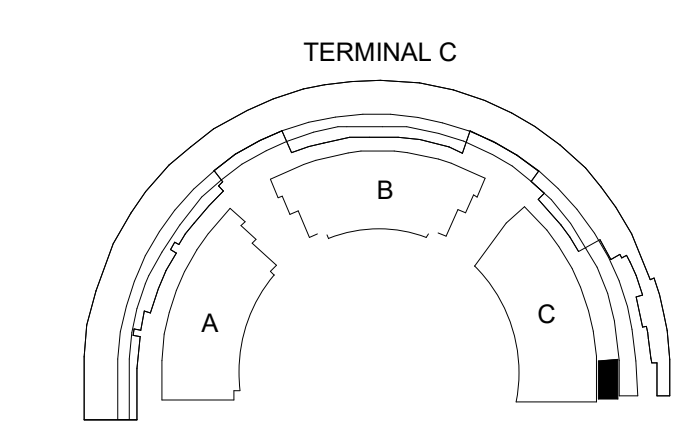

1 FRAMING PLAN - GRIDS 128-133 & RAMP Y (TOP)
1/8" = 1'-0"

DFW DALLAS FORT WORTH INTERNATIONAL AIRPORT
2330 N INTERNATIONAL PARKWAY
DFW AIRPORT, TX 75261



AG & E PROJECT # 21084.00000
15200 Addison Road, Suite 310
Addison, Texas 75001
Ph: 214.502.7502
www.agenie.com
TX REG. NO. F-8439
1-214-722-6000

DRAWN BY: ADD/GY
APPROVED BY: KW
ISSUE DATE: 2022-07-28

NOT FOR BID OR CONSTRUCTION

NO.	DATE	DESCRIPTION
2022-01-09	37% DESIGN	
2022-03-01	100% DESIGN	
2022-07-28	100% ISSUED FOR PERMIT (IFP)	

DFW TERMINAL C GARAGE AND ROADWAY
ROADWAY FRAMING PLAN - GRIDS 128-133 & RAMP Y (TOP)
PROJECT NUMBER: TFD-007
PERMIT NUMBER: B22-0023

SHEET NUMBER
S-164-900R

SCALE(S) AS NOTED ON THIS SHEET ARE BASED ON A FULL SIZE 30 X 42 SHEET.