

Director of publication: Peter De Clerck

Editor-in-chief: Natasha Antunes

Although we make every effort to ensure the accuracy of Engineer Innovation, we cannot be held liable for incorrect information. Images published in this publication have been supplied by customers and published with their permission.

85166-11 03/23

ISSUE 11

Engineer Innovation

A Simcenter publication

A brighter future by engineering innovation



This edition of Engineer Innovation has been curated as a remedy for the winter blues and the pervasive sense of negativity propagated by mainstream media. While it can feel like the world is constantly lurching from one crisis to another, we're here to offer a refreshing perspective. Our articles aim to inspire and uplift, showcasing the innovative solutions and breakthroughs being made by engineers around the world.

As I write this, the global economy is grappling with the aftermath of COVID-19 and facing an energy crisis that threatens to tip it into a recession. Inflation, supply chain disruptions, and skill shortages, particularly in engineering, are exacerbating the situation. Meanwhile, the urgent need to reduce greenhouse gas emissions to mitigate the worst effects of climate change looms large.

Engineering innovation holds the key to solving these challenges. Even during times of economic downturn, engineering simulation has proven to stimulate innovation, reduce development timelines, and enhance productivity.

In this issue, we showcase how engineering simulation is driving sustainable and profitable subterranean farming and enabling low-carbon travel on land, air, and sea. We also explore solutions to energy security, cold chain logistics, and increased productivity through robotic automation.

We hope that reading this issue instils a sense of hope and optimism. Engineers have always been at the forefront of problem-solving, and we are confident that with continued innovation and collaboration, we can overcome any obstacle.

À bientôt,
Jean-Claude



Contents

Explore the possibilities

- We're gonna need a bigger farm** 4
- Robots that always deliver** 16
- Gas-planning for the unexpected** 28
- Where's your analysis?** 34
- The height of comfort** 48

Stay integrated

- Color-coding clears congestion** 44
- Not your everyday racecars** 54
- Building ships in the clouds** 60
- Electromagnetic compatibility and aircraft safety** 64

Model the complexity

- A family of virtual humans accelerate road safety certification** 20
- Hydrogen-powered aircraft for sustainable flight** 40

Go faster

- Luxury refrigeration begins with a lettuce for a llama** 10
- High-speed and zero emissions** 52

Regular features

- Interview: Going underground** 24
- Geek Hub: When science meets art** 70
- Brownian Motion** 76



EXPLORE THE POSSIBILITIES

We're gonna need a bigger farm

Solving global food shortages with subsurface agriculture

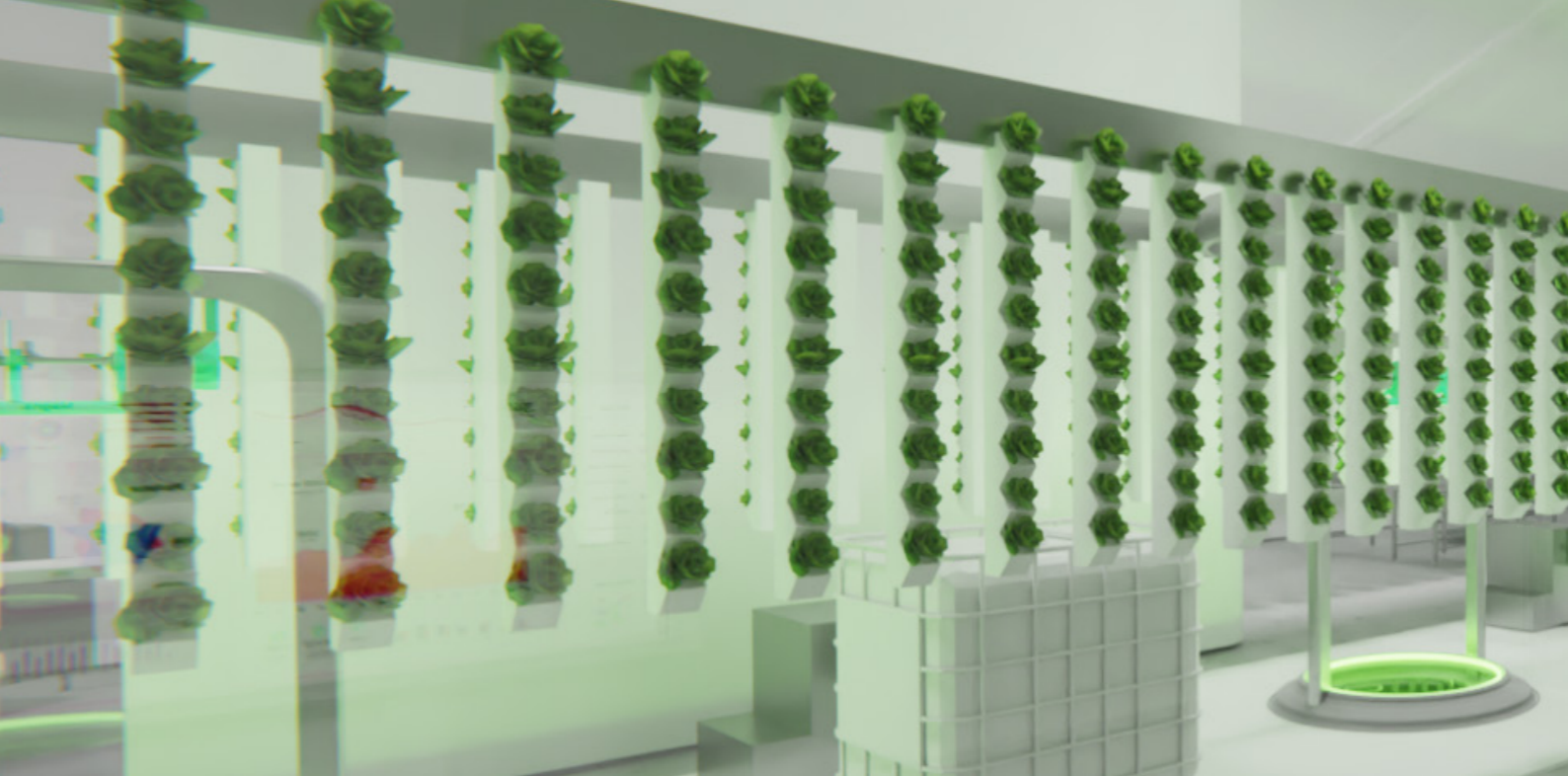

In 2022, the population of Earth reached 8 billion and it shows no signs of slowing down its growth - the United Nations estimates that we will reach 10 billion as soon as 2050.

While this population increase is a testament to modern civilization and the advances in healthcare that keep more people alive for longer, it also presents problems. A major one being how to grow enough food for everyone.

Agriculture already [takes up 50%](#) of the world's habitable land so it's impossible for it to grow indefinitely in line with the population. And with traditional farming accounting for [70% of global freshwater withdrawals](#), a water shortage is inevitable at some point if methods remain the same.

Not only is there a limited amount of agricultural land suitable for crops, but climate change is making farming more challenging in some parts of the world. There are already regions where millions go hungry due to unequal distribution, political instability, and environmental changes. If we don't plan adequately for the future, this century could see a gradual spread of food

shortages to even the richest, most equal countries. The Earth simply isn't capable of producing enough food for an ever-increasing population.

Not with current farming methods anyway.

What if we weren't limited by the amount of farmland available? And what if we could take the climate and weather out of the equation?

Going underground

[GreenForges](#) was founded to combat food shortages by moving agricultural production underground. The idea was initially sparked by much older technology - the water well. This takes up very little space on the surface but provides a steady, regular supply of water. Why not do the same with crops?

The first designs take their shape from wells - cylindrical vertical shafts with a diameter of 1.5 metres. The current model is 15 metres deep which allows for a surprisingly large number of plants to be grown. These 'forges' are then arranged in a grid system and scaled up as much as needed. Each provides 15 metres of growing space but only takes up 1.5 metres of surface space. Except they won't really be taking up any extra surface space at all as they're designed to be installed within the foundations of buildings. So as

the population grows, we can increase both living space and agricultural output at the same time.

The casing of the forge is made of specially coated steel that is non-corrosive, antimicrobial, and light reflective. It uses a hydroponic system - water mixed with nutrients and oxygen - in a continuous loop system. Nutrient and oxygen levels are constantly monitored and replenished while at least 90% of the water is recycled back into the system. Not only does this save on water usage but it also creates a barrier to prevent pest contamination.

Temperature and light are fully managed too, giving much more control over plant growth - harvest cycles can be expedited, and more precise and refined flavours can be developed. So, instead of being reliant on the seasons and subject to extreme weather, food production can be maintained at the same levels all year round, whatever is happening in the atmosphere.

Leafy greens and herbs were chosen as the first crops as they require less nutrients, energy, and light, and have faster harvest cycles. They also tolerate variations in the environment much better. This means that GreenForges can iterate on their design much faster, regularly improving the overall performance of their structures while still having a high production success rate.

"In the first two weeks of growth, we assume almost no humidity generation," says CTO, Jamil Madanat. "Evapotranspiration is very low and then increases exponentially in the majority of crops. Also, at different sizes, these crops breathe differently and have different humidity,

temperature, and light requirements. Leafy greens and herbs have a much narrower window of variation, so they are easier to work with initially. As we validate each type of crop, we will be able to gradually build on top and add a wider variety."

Simulation-accelerated development

So how did GreenForges go about developing their solution?

Madanat explains that they split the design into structural, mechanical, electrical, and digital systems. "The biggest challenge was in creating the climate control system," he says. "It must be very finely tuned, especially as we expand to a wider variety of crops. We need to understand how heat transfer happens at different soil levels, with different soil types, and in different humidities."

Of course, they couldn't dig hundreds of holes to experiment on - that would be far too inefficient and costly. So, they utilized simulation to refine and optimize the design before anything went underground. As the simulations were so complex, Madanat turned to Siemens partner [Maya HTT](#) for their expertise.

Using Simcenter 3D, Maya HTT created virtual prototypes of the thermal and flow interactions within the forge. Specifically focused on energy efficiency and water usage, they predicted the cooling load based on both the conduction to and from the surrounding soil and the heat caused by the lighting.

Carl Poplawsky, engineering services manager at Maya HTT, explains that "you have a temperature gradient as you go down below the surface until the earth reaches a relatively constant temperature. So, you need a heating, ventilation, and air conditioning (HVAC) system to control the temperature and remove the condensation that collects at the bottom."

Simcenter 3D can accurately predict the condensation that collects on the walls as well as the relative humidity distribution throughout. So, Poplawsky and his team were able to simulate all of this to inform the optimum design of the forge before anything was manufactured. "The great thing is that it doesn't require any additional coding," he says. "Straight out of the box the

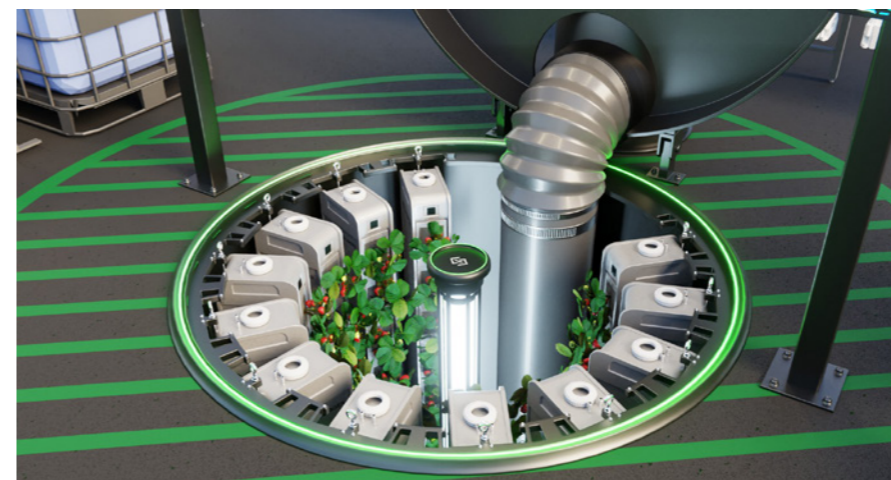

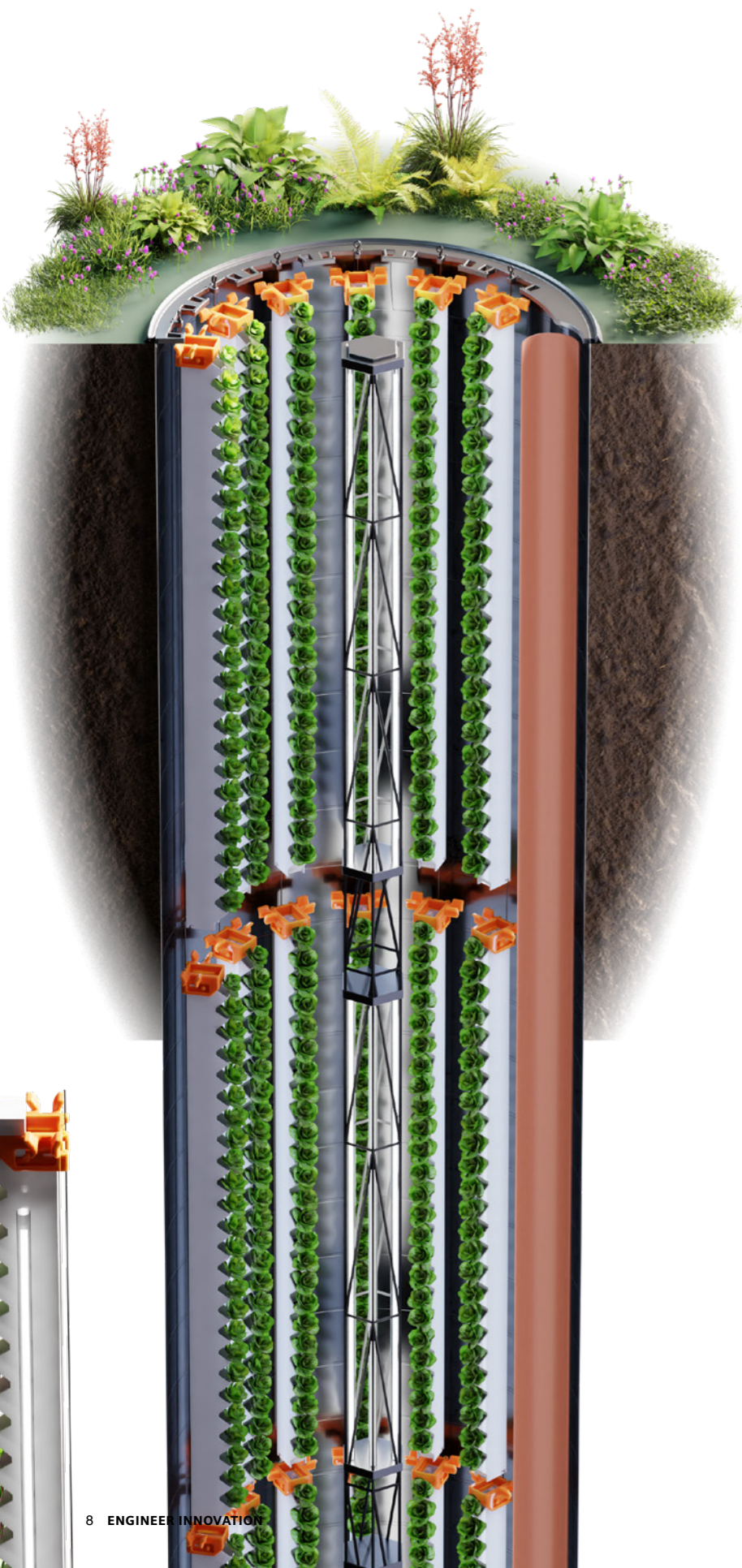

software can handle temperature gradients and humidity distributions. So instead of drilling hundreds of holes to test on, we're drilling all the holes in a virtual environment and simulating the thermomechanical performance flow performance. GreenForges then only need to drill a couple of actual holes because they'll have a much higher probability of success thanks to the virtual prototyping."

Combined expertise

It's been a close-knit collaboration between Maya HTT and GreenForges. Madanat and his team are the experts in the mechanics of underground farming – they provided Poplawsky's team with all the necessary boundary conditions: the cylinder of earth that each forge sits in, the heat dissipation of the LED lights, the transpiration of the vapour from the plants. Maya HTT then created the simulations that show how all the parameters interact. They can then change the locations of elements such as air ducts, inlets, and outlets in the virtual environment, and simulate how this will affect the performance of the HVAC system.

The simulations found that the effectiveness of the underground farm is heavily dependent on both the soil type and the amount of moisture it contains. It was important to understand how the size of the earth domain around each forge would affect the performance, so a full analysis was carried out to show the temperature with a certain size of cylinder. This also informed how close together the forges could be placed without impacting each other.

As well as predicting the temperature at different depths, the simulations needed to produce a velocity profile of the air. The air pumped around the forge by the HVAC system can't travel too fast as it would tear the leaves off the plants. You can set the force with which it is pumped down the forge, but then you need to understand how fast it will come back up. By accurately predicting this, the simulations can show if the design needs to be adjusted to limit the speed to protect the plants.

First the Earth, and then?

When you start to think about all the possibilities that underground farming offers, it's incredibly exciting.

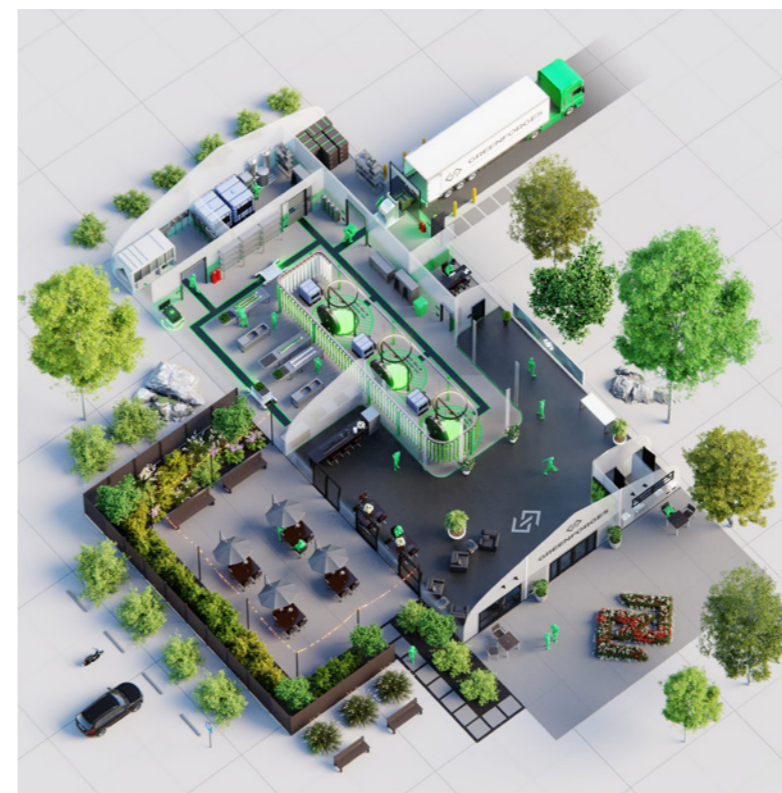

sufficient – not only powering themselves with solar energy but providing all the food their residents need. This would also cut the energy consumption of supply chains that transport food from farms to shops and houses.

With stable temperatures beneath the surface, inhospitable areas such as deserts, mountain regions, and extremely cold regions could become food production powerhouses. Communities in these areas will need to rely less on importing food and become healthier and wealthier. There will be no need to sacrifice forests and jungles to create space for traditional farms.

And if this can be successfully proven on Earth, why stop there? With the exploration of the Moon and Mars targeted over the coming years, it seems only a matter of time before off-world colonies are created. Keeping them fed will be one of the biggest challenges, but if they can grow their own food underground that will be one less thing to worry about.

As long as we need food to survive, innovative farming solutions such as this will be vital to life on Earth and beyond. Visit www.greenforges.com for the latest developments and to find out when your food could be coming directly from under your floor.

Consider the acres of farmland currently required for growing crops. If you can move a significant proportion of this below cities, then all that freed-up surface space can be regenerated.

By installing farms within the foundations of buildings, urban development will have a linear relationship with increased agricultural output. Homes of the future could be completely self-



GO FASTER

Luxury refrigeration begins with a lettuce for a llama

In a windowless lab in Madison, Wisconsin, Sub-Zero Group, Inc. grows 105 heads of Nevada lettuce every three weeks. It harvests the mild, sweet variety to test different models of its namesake refrigerators. Yet it's simulations using Simcenter Amesim, constant adjustments to functionality, and collaboration with designers that advance a Sub-Zero refrigerator beyond a cold box and into a luxury appliance.

With over seven decades of history behind its name, Sub-Zero knows the value of distinguishing its brand as a monument to food preservation and a means to beautify the kitchen. The company is internationally recognized for its commitment to performance and aesthetics.

Anderson Bortoletto, Principal Engineer of Advanced Product Development for Sub-Zero, says the company's goals include building appliances that use less energy, with as high a percentage of recyclable materials as possible. The specifications must be tailored to refrigerator models that offer [proper humidity](#), precise temperature control, and purified air, and give customers a choice of [elegant, customized](#) designs.

Sub-Zero's decades of work have resulted in spectacularly evolved machines: refrigerator models with a wide and spacious interior, clear compartments, and neatly fitting shelves and drawers. The exteriors are smooth and brushed with hand-finished surfaces. The models' hinges, handles, and doors close gently and easily.

"Since our products are top of the line, we need to justify the cost to the customer. We can't afford design that will deliver the most freshness but doesn't look good. We're going for a clean look that promotes and preserves the aesthetic. That ensures the longevity of the brand," says Bortoletto.

A decade down the road, a Sub-Zero refrigerator still needs to be identifiable as a model made by the company. It has to showcase high-end refrigeration and sustainability. It must also communicate, to owners and guests, that it is a premium product.

It's fitting that Sub-Zero has been meeting this challenge since 1945. That year, founder Westye F. Bakke built his first freezer prototype, from salvaged scrap metal, to store his son's insulin at a consistent temperature. Bakke later asked architect Frank Lloyd Wright, for whom he had done work in the 1930s, to customize the first Sub-Zero models.

As today's Sub-Zero's product engineers focus on components, parts, and air flow, the company's designers are equally hard at work. They're busy



crafting numerous desirable features, including flush installation, a wide variety of sizes and configurations, and a choice between the classic stainless steel Sub-Zero look or a panel-ready model with a custom finish.

They're also making it possible for refrigerator models to be customized. This means the appliances can be flush with cabinets and drawers around them. They lack visible hinges and grilles. The refrigerator designs give a kitchen a seamless look. They also make it easy for an owner to move about in the kitchen.

After weeks of tests, when the lettuce finally wilts, a Sub-Zero employee takes the heads home to feed to their pet llama. It's the data that the product engineering and design teams gather, from a head's first day to its last, that become the focal point.

One of the difficulties in finding the balance between aesthetics and performance is that most insulating materials are opaque. That means they're unattractive, says Terry Hardesty, Corporate Manager of Advanced Development at Sub-Zero.

"Customers expect crystal clear drawers so they can see the food in the fridge. They don't want to have to open two to three hatches to get at items. At the same time, they're looking for high food preservation. We work to ensure that the drawers and open space are beautiful, easy to access, and perform well," says Hardesty.

The temperature of the whole refrigerator is not always as important as the temperature across a compartment. Sub-Zero's team uses simulations to determine how a particular design and adjustments to various parts create a microclimate without a large temperature gradient front to back. The simulations allow Sub-Zero to shorten development time and reduce the amount of capital, expense, and manpower spent on product development.

Data collection and refinement assist engineers with developing a smarter control algorithm that will allow the refrigerator to dynamically respond to perturbations. Examples include opening the main door and adding new items.

"How will the refrigerator react if I put two six-packs of beer into it? How will it react if I load

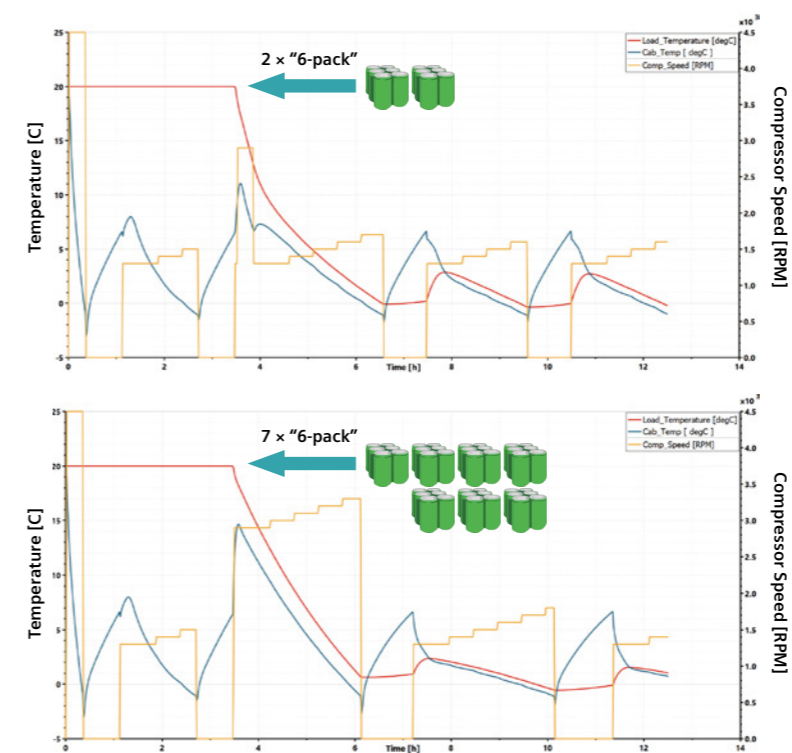

Dynamic response of the appliance to perturbations

it up with 7 six-packs? The machine may have a different dynamic response for each action. Those are insights we want to have before we build an appliance. We want to get this information early on in the design process," says Bortoletto.

How Simulations Improve Closed-Loop Systems

A refrigerator is a heat pump, continually transferring heat from inside the "box" to the condenser coils outside. It uses many components to accomplish this task, including insulation, an expansion device, heat exchange in the evaporator and condenser, and fans. The compressor is particularly important. Its job is to circulate coolant in the fridge. The electric motor that powers the compressor accomplishes its task by compressing refrigerant gas. The action generates heat, which is eventually released by the condenser.

Since energy efficiency is important to both regulatory agencies and their clients, Sub-Zero looks to minimize the amount of electricity that a refrigerator uses. They work to get every Sub-Zero fridge to use less than the U.S. minimum standard for refrigerators. A [U.S. Energy Star](#) certification reduces a refrigerator's carbon footprint, lowers a

customer's utility bill, and in some jurisdictions, qualifies for rebates.

Simulations by Simcenter Amesim give Sub-Zero license to explore what parts like a compressor can do, at minimal cost.

"It's a lot easier to test out an idea digitally. When we build a product to try it out, that takes more time and money. Right now we're developing good correlations between the simulations and reality. The relief we get from that has been psychologically transformative. We evaluated a few other tools before using Amesim. They just didn't work for us," says Hardesty.

Variables that Sub-Zero is able to test with Simcenter Amesim include the gasket, or the air-tight seal along the edges of the refrigerator and freezer doors, the speed of fans inside and under the refrigerator, the capacity and efficiency of the compressor, and the suction line heat exchanger, a component that regulates the refrigerant flow and pressure while maximizing the cooling capacity.

The closed loop refrigerating system model has been developed to also decrease the total testing time spent on defining the optimum refrigerant charge and capillary tube restriction leading to maximum energy efficiency. The goal is to decrease design exploration time from two months to one week.

"With simulations, we can test anything from the length of the compressor run time to how long the operator fan is on. We don't have to build prototypes. The various factors affect how much water an exposed head of lettuce will lose over time. Then we can evaluate what the refrigerator is doing and associate the impact on preservation," says Bortoletto.

The Role of Maya HTT

Sub-Zero is able to accomplish a great deal with Simcenter Amesim partly because it works closely with Maya HTT, a long-time partner of Siemens. Its staff frequently collaborates with Siemens to offer clients software, testing, AI, and engineering services. Maya HTT was integral in Sub-Zero deploying Simcenter and leveraging it with their refrigerator development.

Runs	charge of fluid	Production length
Run 1	30	19.2
Run 2	30	31.2
Run 3	30	43.2
Run 4	35	19.2
Run 5	35	31.2
Run 6	35	43.2
Run 7	40	19.2
Run 8	40	31.2
Run 9	40	43.2
Run 10	45	19.2
Run 11	45	31.2
Run 12	45	43.2
Run 13	50	19.2
Run 14	50	31.2
Run 15	50	43.2
Run 16	55	19.2
Run 17	55	31.2
Run 18	55	43.2

Batch run of 18 cases with more than 3 cycles ran under 15 mins

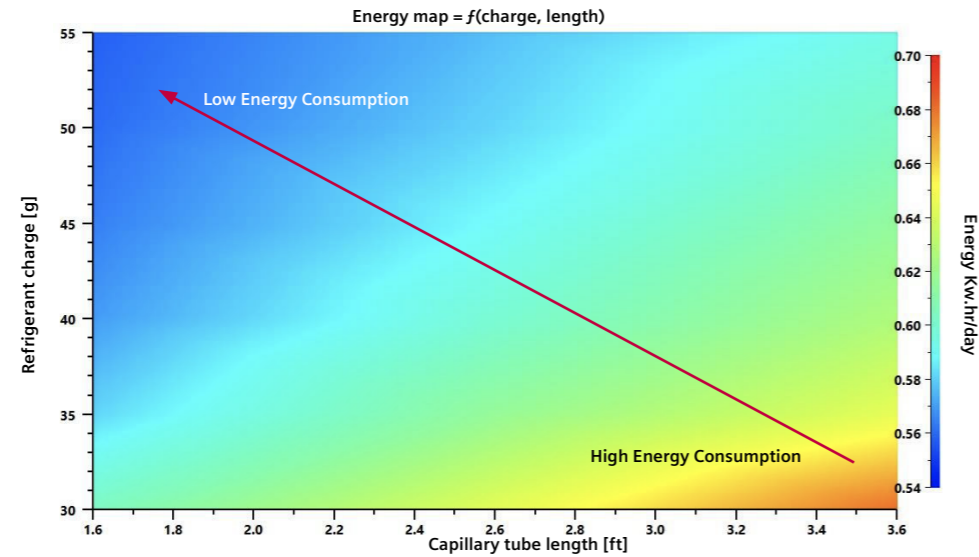

Simulation takes over trial and error testing. Bring down design exploration time from 2 month to a week

The first phase involved building a library of components in order to model the entire fridge, including the heat exchanger within the fridge, optimizing the whole system, and making it run better in the simulation. In the second phase, Maya HTT made a library of components for the refrigerant loop, in which coolant circulates to cool the fridge. The third phase saw Maya HTT finishing the fridge component loops, adjusting the heat exchanger and condenser, and optimizing the overall efficiency of the fridge.

The library of custom Simcenter Amesim components was particularly helpful.

“This extensively customized closed refrigerant loop library has allowed Sub-Zero to maximize efficiency, with components tailored precisely to their products,” says Garrett Keenan, Maya HTT.

Bortoletto says the beauty of the relationship is that Maya HTT has an in-depth understanding of Sub-Zero’s people and appliances.

“Since they’re our long-time partner, they’ve gotten to understand what we’ve been trying to accomplish over time. Without Maya HTT, we couldn’t have gotten closer to the ideal end state for the refrigerators,” says Bortoletto.

The 1D simulations that Sub-Zero accomplishes with Simcenter Amesim provide many advantages. These simulations have a low computation cost, offer a system-level/parametric study with a quick turnaround, and provide fast and easy model preparation.

Sub-Zero is transitioning to using simulations as naturally as any physical product development tool, says Scott Wareing, senior vice president of operations and product design for Sub-Zero.

“Engineers will model and simulate components, sub-systems, and entire products prior to being physically built. Simulation becomes a core competency,” says Wareing.

Sub-Zero’s next move with Simcenter Amesim will involve using the software to refine Cove, its line of dishwashers.

Bortoletto wishes Sub-Zero could have started with dishwashers.

“They’re an easier product to model with simulations. After using Simcenter Amesim to improve refrigerators, we know what we’ll learn,” says Bortoletto.

Simcenter Amesim will help with modeling and predicting the behavior of a dishwasher, such as different types of cycles. It will also allow engineers to reduce cycle time and attain minimal water usage.

“These things impact the environment in a positive way and improve the performance of the product,” says Bortoletto.

For now, Bortoletto says Simcenter Amesim will remain a “big enabler.” The tool boosts Sub-Zero’s capacity to adapt to ever-evolving consumer expectations.



Present



2023



2023-Forward

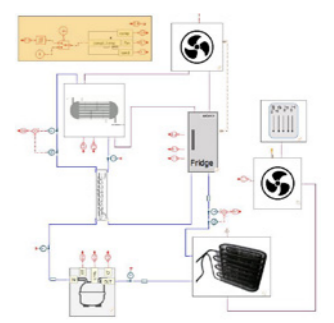

Challenges / Next Steps

“We always want to find the sweet spot between food preservation, great design, and energy consumption. We try to evaluate those attributes simultaneously. Finding a way to decrease the time and cost to get those insights hasn’t led to an enormous design breakthrough. Sometimes that takes years,” says Bortoletto.

Bortoletto says Simcenter Amesim currently gives Sub-Zero the chance to clearly define objectives and validate models before implementing changes. Later simulations may help Sub-Zero write better algorithms for software to power smart refrigerators.

Bortoletto foresees refrigerators becoming easier for owners to adjust.

Using an app on a smartphone, a customer may be able to change the machine’s settings to preserve a particular type of cheese or beverage in a certain spot. They’ll also be able to ensure that a machine is energy efficient overall.

“Currently, customers want a Sub-Zero refrigerator because the machine offers the ability to maintain optimal conditions in refrigerator microclimates, coupled with reduced energy use, green materials, and luxury design. These reasons will remain why a customer will want a Sub-Zero refrigerator for years to come,” says Bortoletto.





EXPLORE THE POSSIBILITIES

Robots that always deliver

Fully autonomous machines that bring parcels right to your door, no matter which floor you're on.

We've all heard about the work from home revolution that's been accelerated by the COVID-19 pandemic. As companies across the world have seen that staff can be as or even more productive working remotely, many have switched to hybrid offices that give individuals flexibility on where they are based.

But the pandemic and the shift towards remote working have accelerated another trend – home deliveries.

Naturally, when most retail outlets were closed there was a huge spike in online orders as it was the only way to get hold of goods. This levelled out as lockdowns ended, but again, as people have realised the convenience of home deliveries, they are continuing to steadily grow at a much higher rate than before.

For shoppers and delivery drivers alike this is easy enough if you live in a house with your own front

door, but what if you live in an apartment block? Either the delivery driver has to spend lots more time and energy getting to each individual door within the building, or goods have to be delivered to a reception area and distributed or collected from there. The latter raises potential security and capacity issues that make it less feasible as time goes on. And delivery drivers want to make their drop-offs as quickly as possible to ensure they get round all their customers.

Soon, there will be another solution available that's ideal for both residents and delivery drivers alike.

Introducing Lu

Lu is the flagship product from Earth Robotics that's set to make apartment block deliveries easier for everyone.

It's a fully autonomous robot that will take packages from the main entrance to the front door of the recipient, all by itself.

"When we say fully autonomous, we mean no human intervention is required at all," explains Earth Robotics COO and co-founder, Amir Emacha.



“Other autonomous robots and vehicles are currently what’s known as level 3. This means they can do a certain amount themselves but will require someone to constantly monitor or take over operation at some point. Lu is level 5, as it operates entirely independently, thanks to the ecosystem we create inside the building.”

The first stage of implementing Lu is to map the building where it will be installed using lidar. An elevator control system is then installed along with a Wi-Fi mesh to ensure full network and GPS coverage throughout. This enables Lu to call the elevator and be taken to whichever floor it is delivering to. Lu is equipped with six cameras to give it full 360-degree vision, allowing it to identify obstacles and navigate smoothly around the building.

Once all the hardware is setup, residents just need to download an app to receive packages. They get a notification when a delivery has arrived, and they can choose to have it brought to them immediately or schedule it for later. Lu sends

another notification when it arrives and the resident simply opens their door and picks up their package, using the app to unlock the secure case.

Similarly, delivery drivers use a kiosk when dropping off packages. They enter the apartment number and any other key details, then place the package inside the robot and take a receipt for proof of delivery. Just as if they were delivering to an Amazon locker, for instance.

Hardware and software in perfect synchronization

Emacha previously worked in software development, and he says the biggest challenge at Earth Robotics has been combining software with hardware. “You need to ensure the development of both is always in sync,” he explains. “So, it’s vital the technology we use helps the software and hardware be designed together.”

He knew that for Earth Robotics to succeed, they would need the very best tools on the market. “We were fortunate enough to find a Siemens partner,

Maya HTT, who guided us in the right direction. They helped us choose the best products for what we are doing and showed us how to get the most out of them.”

These tools allow the team to design and test Lu first in a virtual environment, and then to combine physical testing and simulation as they optimize the final design. The simulation environment also enables validation of software updates before they are applied to physical robots.

The robot manufacturer also benefitted from Siemens special packaging and pricing which makes these cutting-edge tools more accessible and affordable for small, medium-sized, and start-up companies.

Coming to a building near you soon?

Earth Robotics are currently carrying out the first pilot of Lu in Miami, Florida, where they are headquartered. They have found a building with 700 apartments that typically receives over 400 packages per day - perfect to illustrate how efficient Lu can be. The pilot started with three

robots handling deliveries for the first 10% of the building and has since gradually expanded.

The team are working closely with the building owners and residents to ensure a successful adoption of the technology and to overcome any user issues. “It’s vital to understand the flow of robots and people around the building, especially in the elevators,” says Emacha. “If the robots get in the residents’ way then we will only be solving the delivery problem by creating a traffic problem, which is no good. The adoption plan is designed to make sure residents are benefiting and not seeing any downside.”

Clearly, deliveries within buildings is a task perfect for autonomous robots like Lu. And it’s only a matter of time before they’ll be widely available in apartment blocks across the world. It certainly seems as though they’ll be with us long before level 5 fully autonomous vehicles that don’t need a human ready to take control in an instant. Head to <https://www.earthrobotics.co/> for the latest updates on Lu and to find out when it could be coming to a building near you.

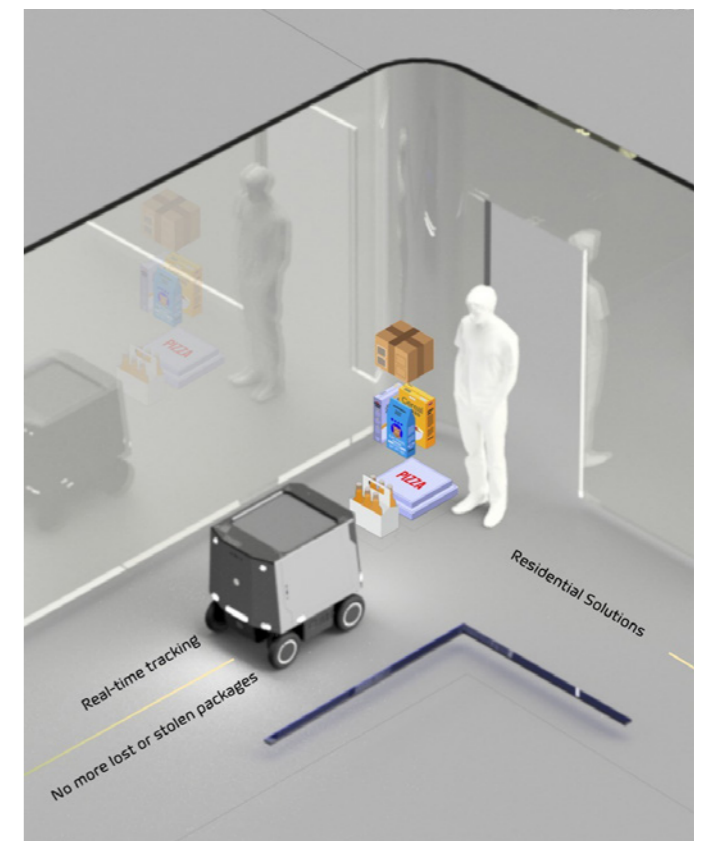



EXPLORE THE POSSIBILITIES

A family of virtual humans accelerate road safety certification

The digital twin helps save lives on the road

Will there ever be zero deaths in road accidents? Nearly 20% of all road accident fatalities in the EU are pedestrians. Head injuries pose the greatest threat of all so reducing them saves many human lives. Accordingly, the WHO and EU require vehicle designs to pass tests that measure the impact to the head in a collision.

If a vehicle design allows more space between the engine parts and the cover, it provides a crush space and reduces the risk of serious injuries. However that can spoil the aerodynamics and aesthetics of the design. The active hood concept solves this design dilemma. It raises the hood instantly if the vehicle hits a person. Global mobility engineering experts, EDAG, aim to rethink and redesign mobility. Combining engineering expertise with a high degree of innovation and an understanding of future technologies, Stefan Hundertmark's team, has been using advanced simulations to model a design for an active hood, and found they could perform more accurate safety testing in the virtual world.

Safety demands tough certifications

As with all new vehicle designs, the active hood must pass the stringent the European New Car Assessment Program (Euro NCAP) safety

requirements. Euro NCAP has particularly tough safety standards and to gain certification for the active hood, EDAG had to prove with certainty that the hood would always be fully raised before it strikes a pedestrian, so that it fully protects the person from the engine parts below.

This was the challenge facing Hundertmark's specialist CAE and Safety department at EDAG. They could not test the concept in the real world because it would destroy many prototype cars, so they performed the tests in a virtual environment. This needed an accurate simulation that would mimic the behavior of the human body at the exact moment of impact.

The need for time efficient simulations

EDAG uses simulation models for testing because they can be completed early in the design cycle, and this helps its customers to bring new designs to market faster. However, the simulations for the active hood were taking time because they needed to show an accurate model of the behavior of a human body at the moment of impact. Hundertmark explains: "The old software worked but the simulations took a long time to run because the models were so complex."

Hundertmark calculates: "From the first contact with the pedestrian until the head hits the hood is around 40 to 50 milliseconds. Within that time, the sensor must send the signal to the CPU that determines if it is a pedestrian and then send another signal to the mechanism that activates the



Safety authorities such as Euro NCAP have realized that the virtual models perform truer to life than physical dummies. We'll see more testing projects shift from physical to virtual simulation because it gives more accurate results"

Stefan Hundertmark, EDAG Group

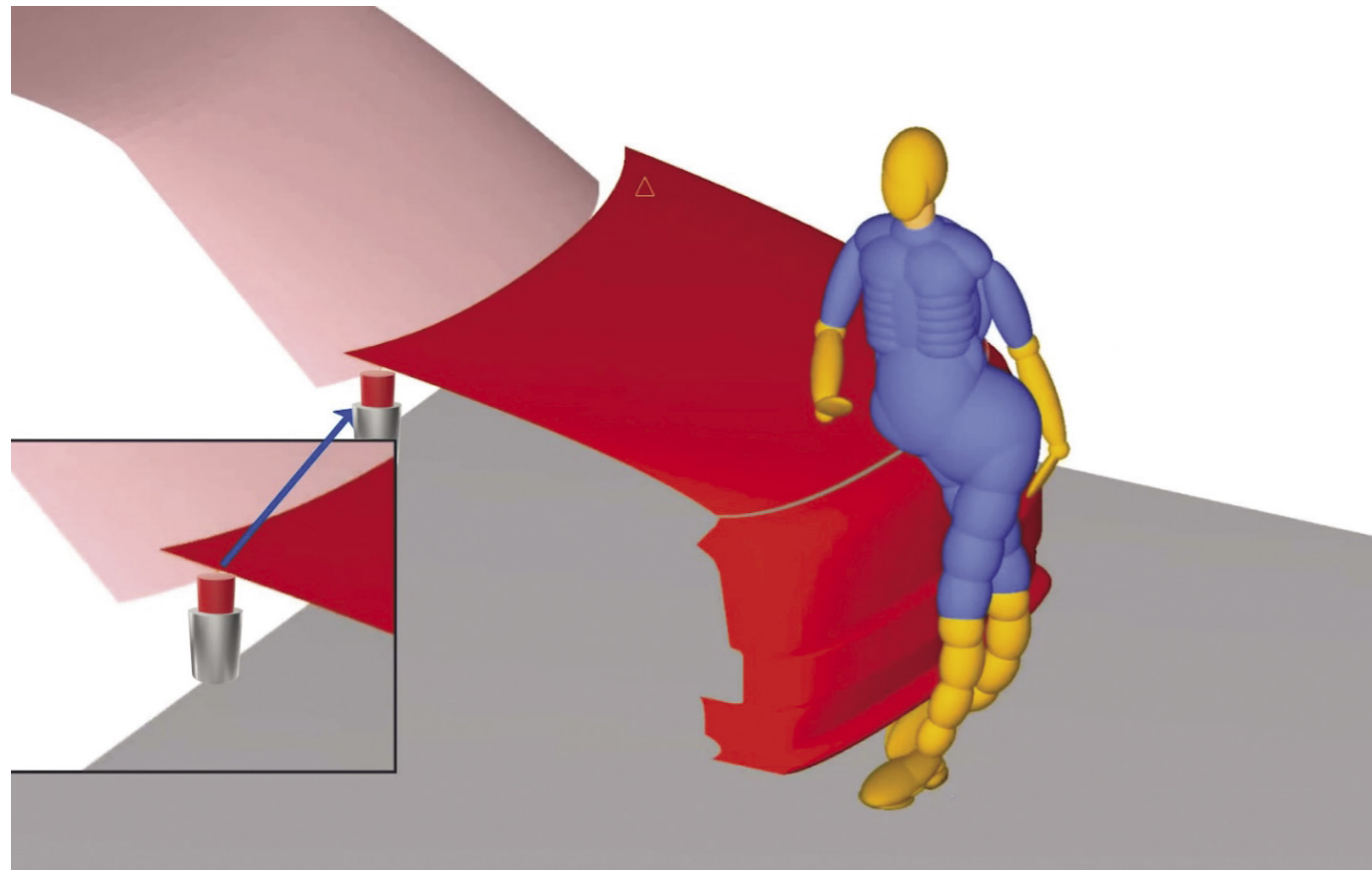

pop-up hood.” This meant that the simulation needed to be exceptionally fast, which is why Hundertmark decided to use Simcenter Madymo. “Because we are dealing in milliseconds, the response times are critical. Simcenter solutions offered us multi-body modeling with the detail of finite elements and CFD to achieve that.”

Modeling kinematic behavior

Simcenter Madymo provides multibody dynamics, finite element method (FEM) and computational fluid dynamics (CFD) all in one solution with an extensive and validated human body model (HBM) database. It also gave the team better tools and support for simulating complex models of human bodies. This meant that the team could simplify their models and simulate just the parts of the body they were interested in, which made a huge difference in the processing times. Hundertmark explains:

“With Simcenter Madymo we can model just the kinematics and that’s all we need to verify that a pedestrian has been hit and send the signal to activate the hood in time. Owing to its multibody capability, the Simcenter Madymo analysis is much

faster than with the previous finite element pedestrian HBMs. It meant that we got the results in a matter of hours instead of days.”

Simcenter Madymo made the simulations much easier. Hundertmark’s team found they were able to perform more simulations, complete their testing sooner and shorten the development time. The software is intuitive and it helped the team to perform the series of tests more easily. He explains: “The requirements for dummy positions and the different angles needed for certification are very strict. With Simcenter Madymo it’s much easier to handle and adapt the dummy as needed. The speed of the simulations also allows us to process more iterations faster so we reach the optimum design much sooner. Ultimately this helps our customers to produce a better product at a lower cost, which is the most important thing to them.”

A compliant and accepted family of human body models

As prescribed by the Euro NCAP regulations, Simcenter Madymo provides an entire family of HBMs: a large male, an average male, a small

female and a six-year-old child. Vehicles need to be tested with all of the models so the set of certified HBMs replaces the traditional crash dummies.

Euro NCAP’s specifications for virtual crash dummies are particularly tough, so the engineers from Siemens Digital Industries Software have to ensure that their HBMs fully comply with Euro NCAP’s validation requirements so that simulation results will be accepted. Importantly, the Simcenter Madymo virtual family does meet the Euro NCAP Technical Bulletin (TB024 protocol) specifications, so they can be used in simulations for safety system analysis certification.

More accurate simulation, safer roads

EDAG Group’s use of advanced simulations puts them right at the forefront of vehicle design. Some manufacturers are still using physical crash dummies, but EDAG and Siemens are confident that the wider automotive industry will follow EDAG’s example. Siemens’ software engineers are already working on a joint industry roadmap and proposals to bring more HBMs into the software-based simulations that lead to certifications, and they have presented these to Euro NCAP and the other relevant authorities. It is only a matter of

time until the proposals will be ratified and adopted which will move safety testing to the next level.

What is the future of vehicle design? Hundertmark believes that the ultimate goal in road safety is “Vision Zero”, which aims to end traffic-related fatalities and injuries by taking a systemic approach to road safety and minimizing the risks in the driving environment. When autonomous vehicles arrive on the roads they should make a difference, and there should be fewer accidents but there will always be the risk of hitting a pedestrian. Hundertmark believes that as vehicles change, pedestrian and occupant protection will evolve too, and simulation will overtake the old tests and play an even greater role to play in road safety. He says: “Safety authorities such as Euro NCAP have realized that the virtual models perform truer to life than physical dummies. We’ll see more testing projects shift from physical to virtual simulation because it gives more accurate results.”

Further Reading:

- <https://www.plm.automation.siemens.com/global/en/our-story/customers/edag-group/110035/>
- [Continuous Automotive Test Innovation within Simcenter Madymo Receives Industry Recognition](#)





INTERVIEW

Going underground

An interview with the minds behind GreenForges subsurface farms

As part of our feature on their underground farms I caught up with two key members of GreenForges staff. Chief Technology Officer, Jamil Madanat and Chief Product Officer, Andrew Stride gave me the full lowdown on everything happening below the surface.

Where did the idea for underground farming come from?

Jamil: Our founder, Philippe Labrie, used to work in building development but he's always had an interest in the world of farming. One day he was looking outside and saw a water well and thought, why can't we do the same thing with food? By going as deep as a well you can save lots of land space. And his experience in the building industry also led to the idea of connecting this with the foundations of buildings. That's where the dream started of a symbiotic system where plants feed oxygen to the building and take the carbon dioxide to feed on themselves.

How did it progress from there to becoming a business?

Jamil: I carried out some feasibility studies initially to see if the idea was viable. The results were very promising in terms of energy consumption compared to other vertical farms on the surface. So, once we knew it was something that could

work commercially, we started building prototypes and running physical testing.

Can you tell me about how you can grow plants underground? How do you ensure they have the right temperature and enough water, oxygen, light, and CO₂?

Andrew: We've designed individual 'forges' that contain everything the plants need to grow. Each forge houses what is largely a closed system - fresh air has to be brought in but all of the water is continuously recycled around the system. We're also looking at reusing the water from the dehumidification process to minimize waste.

We had custom designed LED lighting systems built specifically for us to deliver optimum light to the plants. They're one and a half meters tall with nine LED bars on each. They have adjustable dimming that gives us the flexibility to grow crops that require different amounts of shade and light.

We also have a full HVAC solution providing complete temperature and humidity control so the plants are never too hot or too cold.

It must be a very complex system. How did you optimize the design to ensure successful plant growth?

Jamil: The engineers at Maya HTT have been vital to the project. Plants are very sensitive to humidity and temperature so it simply wouldn't work without an HVAC system that allows us to fine tune the conditions. They helped design simulations that answer questions like how much

the soil will absorb the heat generated by the lights, how will condensation affect the plants, how does the type of soil affect humidity and at what depth does it change. The temperature stabilizes further down but you need to understand the range all the way through the length of the farm. It's very complex physics to be able to simulate all of this and we couldn't have done it without Simcenter and Maya HTT.

You also need to consider how the plant's needs change as they grow. As time goes on, they generate much more humidity so there's more water to be extracted. Simulation allowed us to quickly go through many iterations rather than waiting for plants to physically grow. So, we could change various parameters and come up with the ideal solution much faster. For instance, the first design we tried had a 40-inch diameter and was 100 feet deep. The simulations quickly showed this wasn't going to work so we reduced the depth and widened the diameter and got much better results.

As you said, the main benefit is the amount of space saved on the surface, but are there other advantages to underground farming?

Andrew: Yes, the most obvious thing is the amount of surface space you can save, but temperature and climate control is also a big advantage. Once you dig down to around 20 feet the temperature is pretty much the same all year round. Regions that can't support surface farms due to being too hot or too cold could be suitable for underground farms as we're developing a completely controlled environment that will work anywhere. This also means that we're not reliant on weather at all as everything is happening below the surface. We don't need to worry about overnight frost or if it's going to be sunny enough that week as we can guarantee all the conditions the plants are growing in.

Climate change is a big concern for farming, but our system will help combat this as we can keep crops at the ideal temperature. We could even expedite harvest cycles as we don't have to rely on the seasons above ground.

We have much more control over pests too. We can't completely eliminate them as there are still times when the cover has to be opened. But this is only during seeding and harvesting – the rest of the time we have total control over all the air going in and out, so pests are really minimized compared to surface farms.

Speaking of harvesting, it must be very different to normal farms. How does it work with an underground farm?

Andrew: Yes, harvesting is very different. There's no need for all the tractors and diggers that surface farms use so there will be a significant reduction in the carbon footprint those create. We've designed a fully automated extraction system that brings the modules up to the surface, puts them onto an overhead conveyor belt within the facility, and takes them to a harvesting station. Then the plants can be harvested manually by people or, depending on the customer's needs this process can also be automated. Then when it comes to seeding, we germinate plants in a separate smaller system and then put them into the modules and the automated system puts them back into the farm.

It sounds like all the pieces are in place.

When can we expect to see underground farms in operation?

Andrew: We have a prototype currently running where we're testing all the lighting, cooling, and water supply, and we have another larger prototype currently being built to test that the extraction system works correctly. We're hoping to have a live pilot up and running soon, but it's a case of finding the right site with the right investment. Once we have the site secured and the funding in place, which is a big challenge, we should have the facility up and running within six to nine months.

Fascinating insights, thanks so much to Jamil and Andrew for your time. To find out more about GreenForges, check out our cover feature or head to www.greenforges.com.



// It's very complex physics to be able to simulate all of this and we couldn't have done it without Simcenter and Maya HTT."

Jamil Madanat



EXPLORE THE POSSIBILITIES

Gas-planning for the unexpected

Open Grid Europe models gas flows through thousands of kilometers of pipeline to find answers



Answering the challenge of securing the gas supply in any event. Open Grid Europe (OGE) has modeled thousands of kilometers of pipeline and combined the data with their own acquired knowledge to design a safer gas infrastructure, all while preparing for an energy transition.

Like many of us in industry, OGE need to plan for the unexpected – in this case, any event that could disrupt the gas supply. For example, a customer might suddenly go offline or a power surge could trip in a compression station. Events like these could trigger disturbances in a highly pressurized gas network. OGE is one of Europe’s largest transmission system operators, providing sustainable energy to customers throughout

Germany, and they need to plan for all kinds of risks so that the infrastructure will remain operational under any scenario.

The only way to be sure they can maintain the integrity of the pipelines through any emergency is to identify and mitigate the risks, so OGE aim to understand every scenario that could impact the gas supply network.

A large part of this work relates to understanding the condition of the infrastructure and assessing how well it will meet their energy needs in future. With the global focus on preventing climate change, there has been a shift in the industry to focus on improving gas pipelines to make them more efficient, also new suppliers are entering the market and there is pressure to reduce carbon emissions. OGE is investing in new infrastructure but they also need to monitor the older pipelines and know how easily they can be retrofitted to meet new requirements.

The key to solving these challenges is to understand the fluid flow through a network which is made up of many thousands of kilometers of pipes. Then with that knowledge OGE performs calculations relating to the performance of the networks and finds answers to a number of what-if scenarios.

Safety in all scenarios

OGE needs a reliable set of tools and methodologies to help their engineers understand the flow of gas within the complex network of pipes, so their team use Simcenter Flomaster to aid their understanding of the behaviors of the gas travelling through this huge and complicated infrastructure. Engineers can analyze detailed 1D models and see the results of various what-if analyses that could impact the network. Simcenter Flomaster’s post-processing capabilities allow the OGE team to gather useful results and insights from the data.

There is always a risk that an unusual condition might cause a build-up of pressure in one part of the network, and that could trigger emergency procedures that lead to a big increase in unplanned downtime. Naturally, it is best if these maintenance overheads can be avoided because they impact the steady revenue that flows from normal operations.

The engineers can keep a careful eye on parameters such as gas pressures, temperatures and specific concentrations, and monitor these at the points of metering and importantly all the way along the lengths of the pipes. Over time, OGE has developed their own ways to streamline the workflows and process the calculations which Simcenter Flomaster computes simultaneously for them.

During the ten years that OGE has used Simcenter Flomaster, it has helped them to prevent downtime and make their business operations more efficient overall.

Gas flow physics built in

OGE’s engineers use Simcenter Flomaster to simulate enthalpy-based vapor cycles so that they can study critical parameters under different scenarios and predict the behavior of the gas infrastructure under different conditions. For example, what would be the effect of a change in peak pressures?

Courant-Freidrichs-Lewy (CFL) gas flow parameters are built into the Simcenter tool ensuring that gas flow physics is fully addressed and thus provides faster calculations without compromising accuracy. OGE’s engineers are then able to use these calculations to assess the safety implications of changes to the infrastructure or their operational procedures.

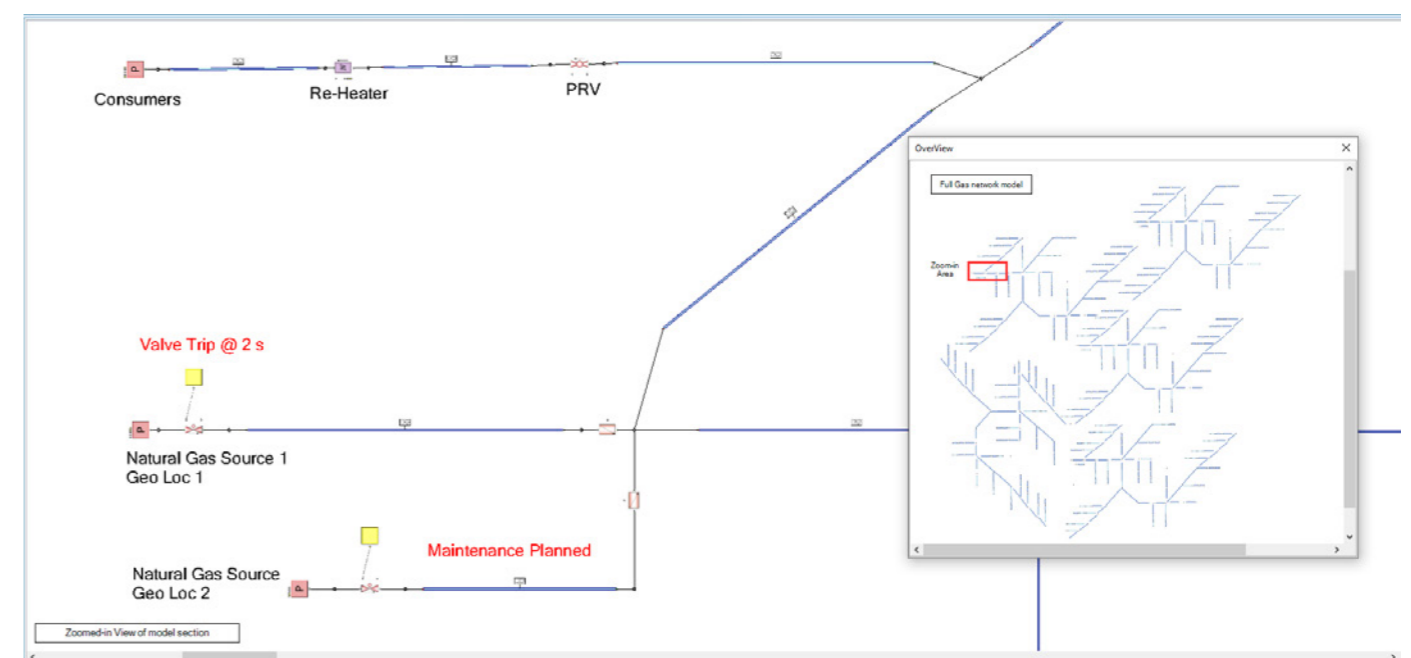

Simcenter Flomaster’s graphical interface shows a small section of the gas supply network and models the effect of disturbances

OGE modelled a change that increases peak pressures fourfold. Would this make the entire system unstable?

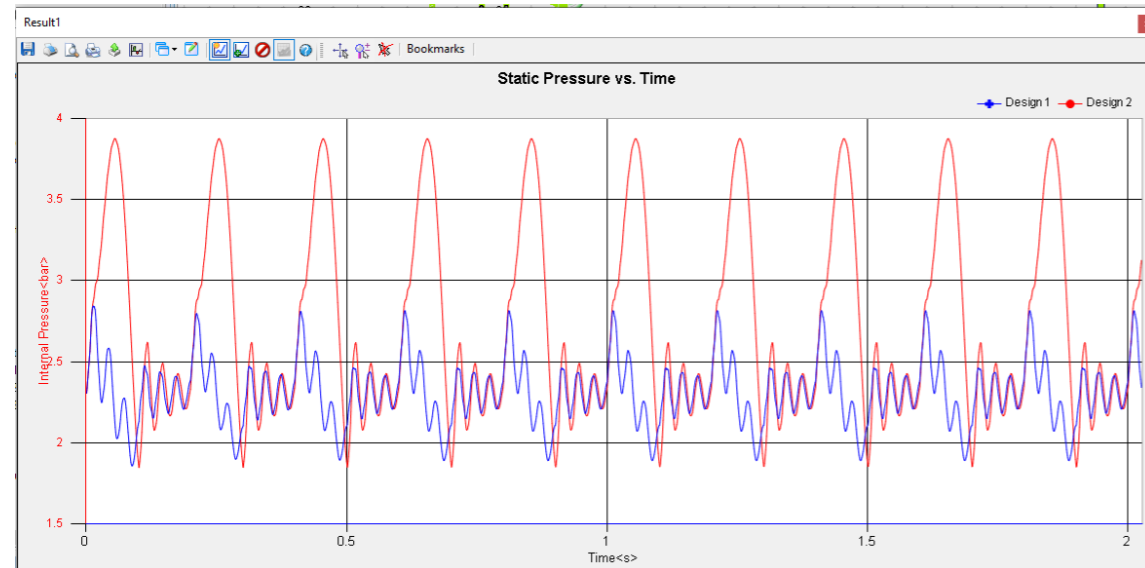

Analyzing supercritical flows of CO₂

OGE's work goes beyond the day-to-day management of the infrastructure, they also plan for the future. The global shift towards more sustainable solutions and cutting carbon emissions has resulted in OGE engineers investigating emerging technologies that will be more sustainable, and planning for the transition to a greener energy supply. They are looking at the emerging use of hydrogen and technologies for carbon capture utilization and sequestration (CCUS).

Many industries, steel in particular, create large outputs of CO₂. As Germany's steel industry, which is mainly located in the Ruhr region, begins to move its CO₂ output to offshore facilities where CCUS can be applied, the existing pipelines could be the way forward. However, the properties and behavior of CO₂ are very different to those of natural gas so it is not immediately clear how well the existing pipeline network would support this requirement, or how they could transport the CO₂ in the most efficient way.

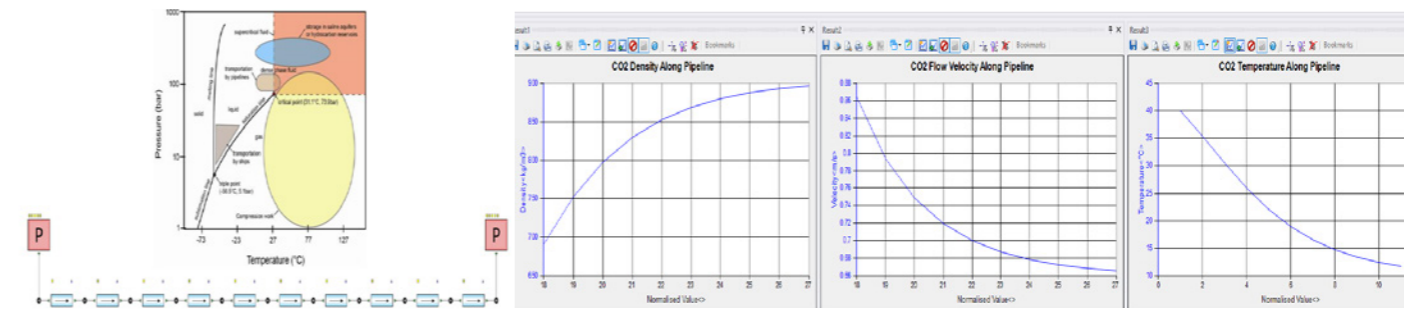

These models show the supercritical phase region of CO₂ where it is impossible to distinguish between incompressible and compressible flows.

These are questions that OGE will be able to answer with further research and investigation. There is a challenge and maybe an opportunity for the OGE team to leverage the benefits of this supercritical phase behavior for more efficient methods of transport in future.

OGE's engineers can use Simcenter Flomaster's enthalpy-based vapor cycle feature to model this and learn more. To find out what will be possible, it is essential to understand pressure-temperature-enthalpy distribution and phase split of carbon dioxide and how that would look across the entire network. Then the model would also need to consider the various points of generation, branching and merges, elevations and heat transfer in the network.

Simcenter provides answers quickly, even when the networks are large and complex, with hundreds and even thousands of kilometers of pipes and branches. OGE's local partner, Smart-Fern, will continue to support their work of assessing the critical aspects of the existing gas infrastructure.

OGE is also interested in using online modules for operational planning. This could form part of a larger, IoT (Internet of Things) ecosystem that would provide real-time insights into the operation of the pipelines and their current condition.

Both OGE and Siemens share the wish to achieve safe and sustainable outcomes that are also financially viable for the energy supply. www.oge.net.



EXPLORE THE POSSIBILITIES

Where's your analysis?

Adding corrosion mitigation to your digital thread

Corrdesa develops and uses computer-aided engineering (CAE) simulation tools to identify and mitigate corrosion risk by optimizing and implementing corrosion-resistant coatings, processes, and equipment ensuring compliance with regulatory and environmental requirements.

[Learn more](#)

I must confess that corrosion isn't something I know much about. Nor is it something I've given much thought to, besides booking an appointment for my car's annual rust-protection treatment. However, since we've started making things with metal, corrosion has been there to foil our plans. Sure, there are tried and tested ways to control the spread of it. However, it didn't strike me as a pressing engineering problem seeking innovation, just a necessary step for durability and safety. It was something I didn't associate with simulation, let alone digital transformation or shifting left.

That was all before I met Dr. Alan Rose, [CEO of Corrdesa, LLC](#). Before we get into who he is and what his company does, he shared an anecdote that reinforced my misguided perception:

Where is your analysis here. Watch now

Corrosion control has traditionally been kind of slapped on or bolted on at the end. I had a friend of mine who worked at a helicopter company, so there are not many of them around. And he'd tell me a story how all the engineers would meet together, and you'd have your thermal engineer, discussing some change and the thermal engineer goes, oh no, you can't do that. It'll get too hot. The aerodynamicist would say, no, you can't make that change it'll be too heavy. The structural engineer would say, oh, you can't do that change. The structure wouldn't take it.

And they'd all have their FEA analyses and the color maps and so on. And then they'd come to my

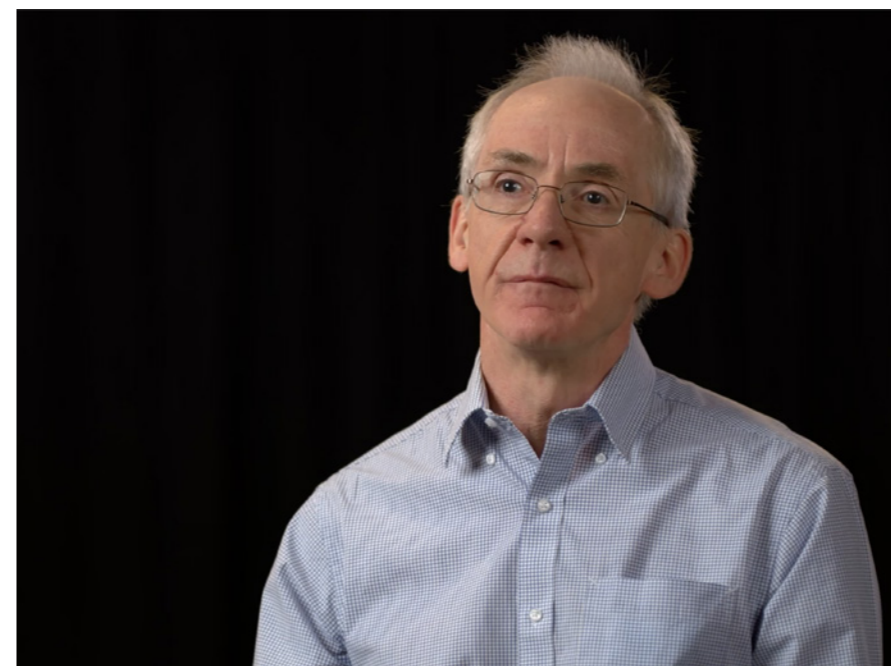

friend who was a materials guy and he'd say, no, you can't do that, it will corrode, or the materials are incompatible. And they'd all look at him and go, where's your analysis?

So, what exactly is galvanic corrosion? According to everyone's favorite AI chatbot, it is a form of corrosion that occurs when two dissimilar metals come into electrical contact with each other in the presence of an electrolyte. One metal, called the anode, corrodes preferentially and loses electrons to the other metal, called the cathode, which corrodes less rapidly. This process can accelerate the corrosion of the anodic metal, and can also protect the cathodic metal from corroding.

Corrosion analysis looks at the impact on materials and equipment. This can include the examination of chemical properties and environmental factors. The goal is to identify the root cause and develop strategies to prevent or mitigate it. Sounds easy enough.

However, corrosion is a slow process, and physical testing can take months to years. Quite the obstacle to overcome in an age where the opposite is expected – shorten design and test cycles. Ideally, by shifting left and getting ahead



So why is corrosion such a big issue?

The new discipline. Watch Now

Why is corrosion a big issue? Well, we have cost, so it's about two and a half trillion dollars of cost globally. So that's like what, about 3% of global domestic product? There's a cost. There's obviously safety, and it takes a long time to test materials and deploy your new coatings and new designs. So, you need to be able to shorten that.

On a cost perspective, we do a lot of work for the Department of Defense, corrosion there costs like \$22 billion a year, and about half of that is for aerospace.

So no matter which way you cut it, there's a lot of money to be saved in quickly assessing and modeling corrosion as part of your design process. Just like thermal analysis, stress analysis, I think now computational corrosion analysis is kind of the new discipline.

If it is such a big issue, then why haven't we seen this discipline popping up in more places? What are the challenges when it comes to implementing corrosion simulation?

Compared to thermal analysis and stress analysis, the biggest difference is the necessary data has been already collected and is available. When you use Simcenter STAR-CCM+, you can very easily find in a database, thermal conductivities, Young's modulus, and so on. But for corrosion analysis, the data just simply isn't there.

Corrdesa has designed a protocol, in our partnership with the United States Navy, on how to acquire that data, and now that's part of a standard. So, people know how to acquire this data and how to actually insert it into Simcenter STAR-CCM+ to do the 3D corrosion calculations.

Now we have not only the tools but also the validated and robust data that enables this technology to move forward.

Physically testing for corrosion can take weeks, months, or years. The elapsed time required to validate results means it's usually deemed too big of a risk to implement new coatings or materials. Tried and tested

of issues earlier on in the process, we could achieve both objectives. Is that possible?

Alan and I discussed this in detail. It's hard to say if he is more knowledgeable or passionate about the topic. Likely both in equal parts. He illuminated to me how, with simulation, the archnemesis of metal can be put into check.

materials win out because they're a known quantity.

Alan doesn't disagree that traditional methods are risky. But he argues that simulation can help companies explore possibilities without jeopardizing their project timeline.

Implementing new materials is definitely a challenge, certainly in aerospace. That's my background, in aerospace. Some argue the best test for materials is actually in the field, but with the pressure to shorten design cycles, can't afford that time. By that I mean putting your sample on the side of a plane or a ship or a car and drag it around Michigan. That can take months or years.

So, then they have beach tests where you put material samples in a corrosive environment on the beach, say down at Kennedy Space Center. That can still take six months. Our accelerated corrosion chamber tests take a month.

if you've got a large project and you're thinking I really need the best and latest in materials, you've got to consider that as a risk. It might turn out that the materials aren't appropriate. So, it's back to the drawing board.

Less risk. Watch Now

But we've developed techniques that can within say about 24 hours you can characterize the materials in a laboratory, laboratory scale. You can then put that material information in your computer model, and you can actually model the corrosion within minutes to a few hours, depending on the complexity of the geometry.

There's a lot less risk now. You can look at many, many other material options rather than just try and figure out what you can do in the time given to you.

Lessening the risk in deploying new materials

If there was less risk in deploying new materials, there is a greater chance they would be used in large projects, leading to more innovation. He elaborated with an industry example:

"An example is automotive. They must go from a blank to market within, say, two years. It takes about 12 months to design the car. That only gives you 11 months to get your tooling done and all the tests. You can only do one full-scale corrosion test, perhaps two. If you can do all this computationally, then that will reduce the risk significantly."

Alan goes on to elaborate that changes in regulations, which requires finding alternatives to toxic materials that have been mainstays, add even more pressure.

The pressure to change. Watch Now

"Traditionally we've been able to use some materials such as cadmium and chromates that are very effective in mitigating corrosion. we find ourselves having to swap out those materials and drop in new materials that are a lot less toxic to our operators and to the environment. Now we've had four or five decades to understand some of these older materials, but we are forced to implement these new materials in shorter time scales, in about five years or so because of legislation like REACH and OSHA and so on."



1990
Numerous studies at the NASA Beachside Atmospheric Corrosion Test Site required an expansion to 600 feet parallel to the Atlantic Ocean. Studies included environmentally friendlier coatings, zinc-rich primers and inorganic topcoats, and silicone ablative coatings. The majority of the testing identified materials, coatings, and maintenance procedures for launch hardware and equipment exposed to the highly corrosive environment at the launch pad.



But it's not just automotive. 80% of aircraft structural failures are from corrosion pits. Can simulation predict and prevent that?
 Yeah, so in teardowns of aircraft, there's been reports have shown that about 80% of structural failures can be sourced back at corrosion pits. The choice of materials and repair methods and sustainment is very important.

Implementing computational corrosion techniques can very, very quickly help you do that by basically getting your result within a few hours.

Who exactly is using all these corrosion prediction techniques?

There are kind of three parts to that. We had to consider what the user personas would be. Now computerized engineering traditionally would require somebody with expertise that knows how to create the meshes for analysis, like in computational fluid dynamics because that's what we're using.

Do you train your materials people to be CAE experts, or do you train your engineering team to be materials experts? You can't do that. We took these personas, the CAD people, computer-aided engineering people, and materials process people, and developed a toolset for their respective needs.

You can do what we call our corrosion Djinn analysis -- that just looks at materials. Have I got a problem here? Is there going to be some issues or incompatibility? And that can highlight on your system where you may have some issues.

Then you might want to drill down and get more details on the geometry. If you have somebody that's familiar with CAD, that person could just take that whole system and then model and predict the corrosion on that 3D assembly.

But if you have a materials process person (MPP), they don't have that expertise. So, we've created a GUI within Teamcenter, where under the hood it runs Simcenter STAR-CCM+ automatically using common fundamental building blocks. What do I mean by that? If you think about it, an airplane is made of lots of nuts, bolts, lap joints, butt joints, etc. We've captured those fundamental geometries.

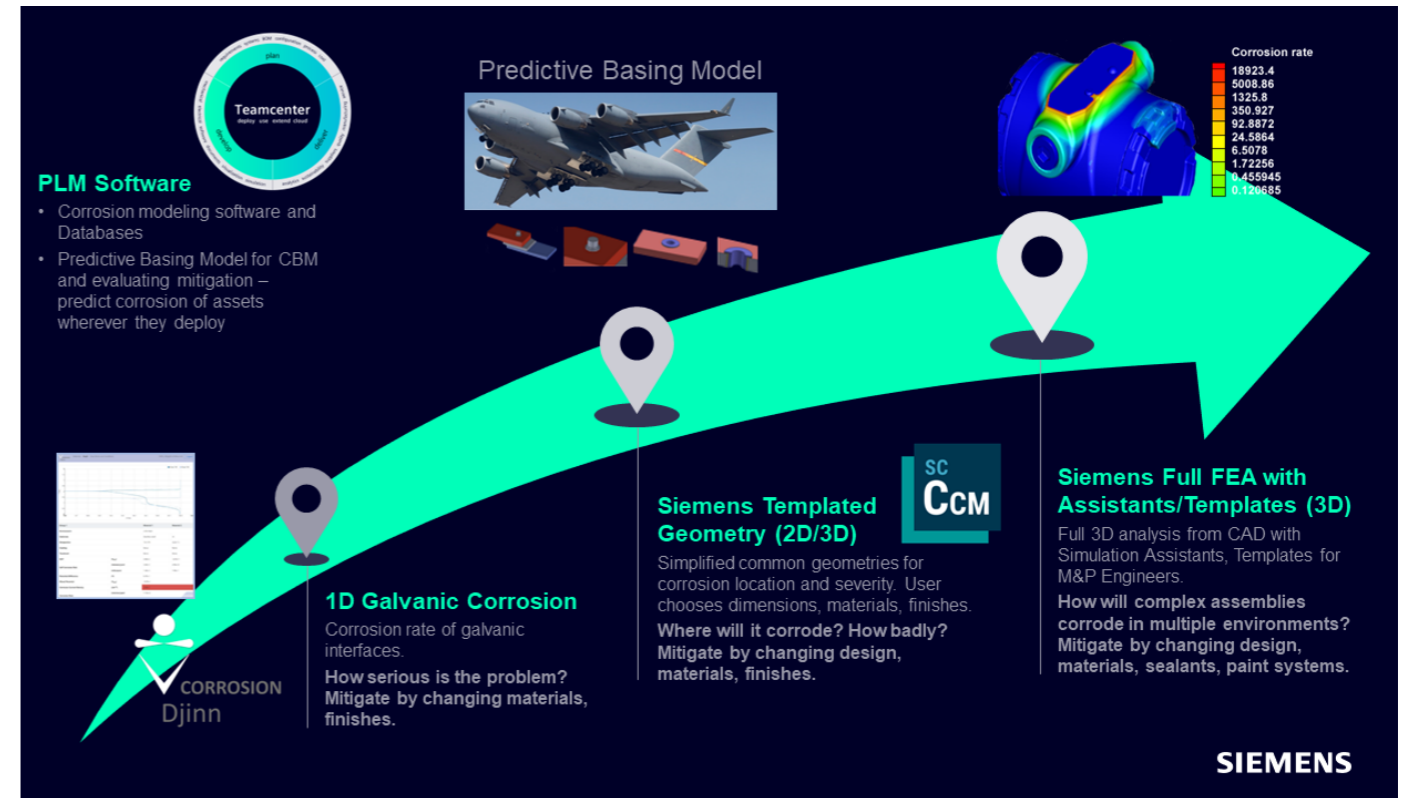

Using that, the MMP can create the mesh and set up the analysis without being a typical CAE user. It then reports back to the MMP guy, the corrosion rates, and the map of the corrosion rate around the whole assembly or sub-assembly. So

Can you build corrosion control from the outset?

That's a good question because that's certainly what the Department of Defense would like. There are standards and guidelines, and requirements, it's called corrosion prevention control planning. And that takes a lot of information. You need to know the materials, the data, and the geometry, and that can all be kind of accounted for and controlled in an environment like Siemens Xcelerator.

[Siemens Xcelerator clip. Watch Now](#)

Corrosion modeling in Siemens Xcelerator makes it possible to build in corrosion control and compliance from the outset. When you're looking at requirements through to surrogate designs and testing and managing all the data all the way

through and predicting the corrosion and durability of that product.

What's next for Corrdesa?

Our USAF project for creating the tool, that is 'The Corrosion Modeling Toolset', finished its first phase in late summer 2022. It has been demonstrated to several maintenance groups responsible for several USAF platforms. This has created a lot of traction and there was considerable interest at the 2022 Aircraft Structural Integrity Program (ASIP) Conference.

We are now in a second phase where we are connecting actual field results from aircraft with simulations from the toolset. Furthermore, we will be implementing a module that will account for changes in the environment and aircraft mission by considering weather data.

In response to traction from the automotive community, Corrdesa is presently working on a project to gather materials and coatings data relevant to automobiles, this will result in about 40 further materials added to the Corrosion Djinn database, thereby extending this capability to Automotive designers and materials engineers.



The capabilities of the Siemens Xcelerator portfolio and the Simcenter tool suite are focused on supporting the digitalization efforts required to scale the aviation industry into this sustainable future.

MODEL THE COMPLEXITY

Hydrogen-powered aircraft for sustainable flight

Using a digital twin to reimagine aircraft design for a sustainable future

Aviation currently accounts for nearly 5 percent of global greenhouse gas emissions.¹ The problem is compounded by the fact that there are currently around 500,000 people in the air at any given time² and twice as many air travelers are expected in 2037 as there are today.³

There are many initiatives being taken to improve sustainability of flight, such as improving fuel efficiency by reducing weight, reducing single-use plastics, investing in carbon offsets, and more.

But, as with road transport, the real game-changer is to find an alternative, carbon-neutral propulsion system. A system capable of transporting passengers with the capacity, speed and range of kerosene-fueled jet engines – but none of the environmental impact.

One of the most promising options currently being explored is hydrogen.

Hydrogen as a sustainable fuel

Hydrogen offers many advantages as a power source for aviation, but generating it is not straightforward. Although it is abundant, it's almost always found as part of another compound such as water (H₂O) or methane (CH₄) from which it must be separated.

There are several common ways to produce hydrogen,⁴ but to power a sustainable aircraft the

most practical method to date is electrolysis. In electrolysis, an electric current is used to split water into hydrogen and oxygen. If the electricity is produced by renewable sources such as solar or wind, the resulting hydrogen is considered renewable.

Once produced, hydrogen can be stored in gaseous or liquid form. Storing gas typically requires high-pressure (5,000 to 10,000 pounds per square inch) tanks, while storage as a liquid requires cryogenic temperatures, because the boiling point of hydrogen at one atmosphere pressure is -252.8 Celsius (C°).⁵

Aerospace engineers developing hydrogen-based sustainable aircraft propulsion systems have three main options: electric motors powered by fuel cells; pure hydrogen-powered gas turbines; or hybrids involving both fuel cells and hydrogen-powered gas turbines.

In the case of a hydrogen-powered jet engine, which is a type of internal combustion engine, air is sucked into the inlet, compressed, mixed with the hydrogen, and ignited to generate a high-temperature flow.

Challenges of hydrogen-powered aircraft

Perhaps the most immediate challenge is that developing a hydrogen-powered aircraft is new territory for most engineers. And designing a burner for a hydrogen gas turbine requires special features and structures.

For example, because hydrogen burns much faster and hotter than kerosene, a hydrogen burner must be designed to prevent flashbacks. It's also



Figure 2. The increased fuselage space of blended wing body aircraft can be used to store batteries, hydrogen or hydrogen and fuel cells without sacrificing passenger or cargo capacity.

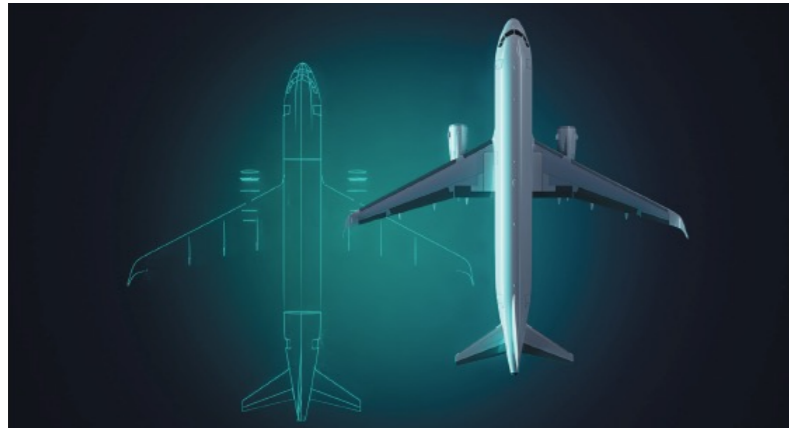

Figure 3. Using Simcenter, engineers can build a digital twin to accurately predict aircraft performance, optimize designs and innovate faster with greater confidence.

necessary to understand the fluid dynamics, along with any stresses that occur at thermal boundary conditions of the hydrogen and electric-powered propulsion systems – including the operational phenomena they encounter such as flashbacks, thermoacoustics, thermal gradients and embrittlement.^{6, 7, 8, 9}

Re-imagining the shape of aircraft

Another key challenge is that although hydrogen provides three times the energy density of kerosene per unit of mass, it requires four times the volume of kerosene to achieve the same result. So, whether the aircraft employs hydrogen turbines or hydrogen fuel cells to drive electric motors, there are major implications for the frame of the aircraft.

Either the cargo capacity, the number of passengers or both must be reduced to accommodate a hydrogen fuel source, or the entire aircraft configuration must be re-imagined.

One exciting possibility is a blended wing body (BWB) aircraft like the Airbus ZEROe BWN concept aircraft,¹⁰ in which the wings and fuselage are blended into a single entity (figure 2). Also known

as a ‘flying wing,’ the entire aircraft provides the lift required for flight.

A major advantage of a flying wing configuration is the increased fuselage space can be used for carrying payloads such as cargo, passengers, batteries, hydrogen and fuel cells.

Digitalization and the digital twin

As the design of the BWB suggests, finding solutions to enable hydrogen-powered aircraft involves far more than re-engineering the propulsion system alone. It requires a convergence of design domains and a coordinated effort between all the engineering disciplines involved in aircraft development.

Engineering data from all these interrelated domains – propulsion, fluids, thermal, mechanical, dynamics, acoustics, and more – must be shared between teams in an efficient manner so designers can continue operating efficiently within their native development environments.

The complexity, combined with cost, time and resource limitations, means that evolving a series of physical prototypes is not a viable design strategy. Instead, the way forward lies in digitalization.

Engineers are using Simcenter simulation and testing solutions, part of the Siemens Xcelerator portfolio, to bring together the various disciplines required to design and build hydrogen-powered aircraft.

The Simcenter provides an integrated design suite that can fully support multi-disciplinary aerospace engineering teams, helping them model, analyze and test the impact of alternative energy sources and propulsion systems – in short, enabling the creation of a physics-based digital twin.

Multi-disciplinary design capability

Within the Simcenter environment, the simulation modeling capabilities enable the evaluation of engine architectures, gas turbines, fuel storage, fuel cells, batteries and other components, as well as their weight (figure 4).

In parallel, engineers can then factor in thermal and mechanical 3D simulations as well as computer-aided design (CAD) capabilities to design each of these subsystems.

Figure 4. The Simcenter Amesim model enables engineers to evaluate the thermodynamic cycle of the hydrogen-powered turbofan.

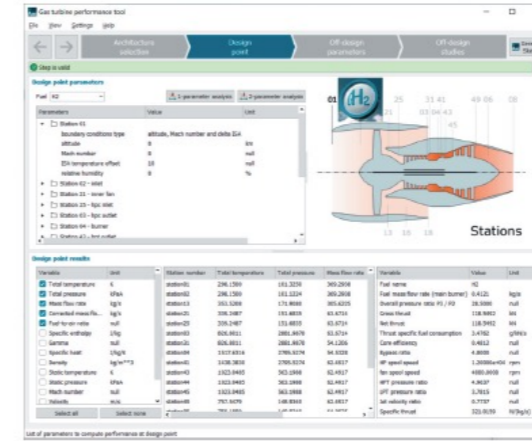

From the sloshing of cryogenic fuels and measurement of turbine inlet temperatures to dynamic system response and component durability, advanced physics are delivered in robust and validated Simcenter models (figure 5).

Automated workflows enable extended analysis of the design space to identify any conflicts from the various disciplines. Components such as the burner and vanes, the engine, the various subsystems and eventually the entire aircraft can be designed using a similar approach to meet precise design specifications.

Simcenter models are generated and executed with real-world fidelity to allow aerospace companies to design and deliver real-world systems (figure 6). In addition, the outputs can be combined with the Siemens Xcelerator portfolio to evaluate component and system manufacturability.

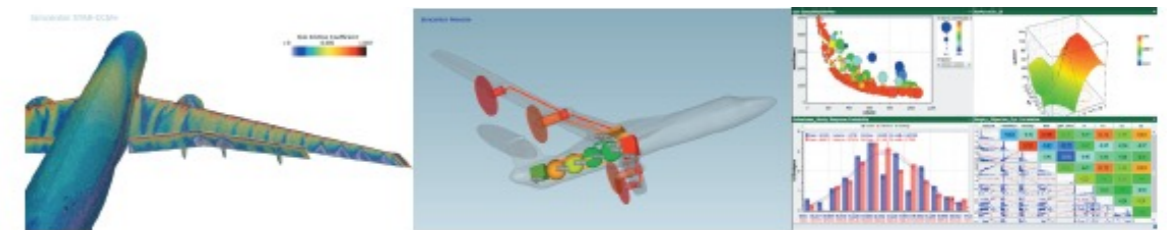

Figure 5. This multi-domain design exploration rendering of a hybrid cryogenic H2 burn propulsion system was generated using Simcenter 3D, Simcenter STAR-CCM+, Simcenter Ames and HEEDS software tools to accurately represent the design's aeroelasticity.

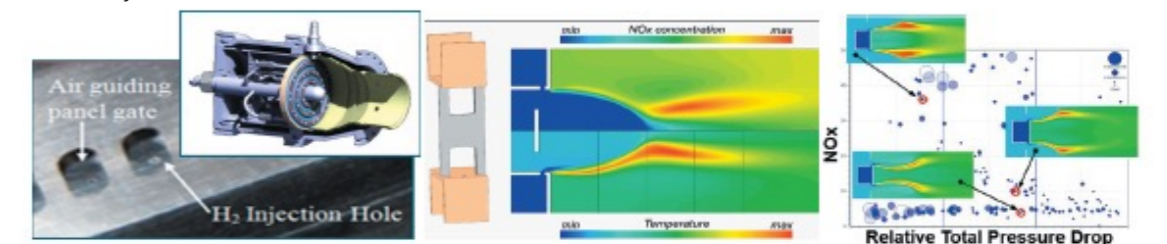

Figure 6. This multi-physics design exploration of an H2 micro mix burner leverages NX CAD, Simcenter STAR-CCM+ and Simcenter 3D driven by the HEEDS automated optimization tool. (source: B&B AGEMA, RWTH Aachen and Kawasaki)

Supporting the journey to sustainability

These activities are just the beginning of a decades-long effort to re-imagine aircraft configurations and address materials supply chains, energy production, distribution and logistics networks, airport fuel delivery systems, and more.

The capabilities of the Siemens Xcelerator portfolio and the Simcenter tool suite are focused on supporting the digitalization efforts required to scale the aviation industry into this sustainable future.

References

- <https://bit.ly/3CxFTPC>
- <https://www.spikeaerospace.com/how-many-passengers-are-flying-right-now/>
- <https://www.bbc.com/future/article/20210401-the-worlds-first-commercial-hydrogen-plane>
- https://afdc.energy.gov/fuels/hydrogen_production.html
- <https://www.energy.gov/eere/fuelcells/hydrogen-storage>
- <https://www.plm.automation.siemens.com/global/en/our-story/customers/siemens-energy/93022/>
- <https://www.plm.automation.siemens.com/global/en/our-story/customers/b-b-agema/98716/>
- <https://webinars.sw.siemens.com/en-US/simulation-for-digital-testing-with-bb-agema/>
- <https://webinars.sw.siemens.com/en-US/aerospace-defense-aircraft-propulsion-system-simulation>
- <https://www.airbus.com/en/innovation/zero-emission/hydrogen/zeroe>

STAY INTEGRATED

Color-coding clears congestion

Eliminating the bottleneck between design and analysis

It's an issue that many companies face – a large design team passes CAD files to a small group of analysts. There's iterative communication between the two disciplines as designs are tested and validated and this takes time. Meanwhile, models back up as they await specialist attention and the ensuing jam reduces productivity, impacting the development process.

Design and computer-aided engineering (CAE) teams typically cooperate to create an analysis request, transfer data to the CAE system, respond to inquiries, create and run the simulation model, generate analysis reports and revise the design. There may be multiple rounds of designing and testing as both sides move towards the optimal solution. This back-and-forth collaboration between designers and analysts is critical because it leads to better quality products. However, there is a downside.

The simulation slow down

Even though complex analysis problems can be solved in a matter of hours rather than days, the fact that designers usually outnumber analysts affects workflow. What may begin as a small time lag in analysis throughput can, after several cycles, end up as a considerable delay. Depending on the complexity of the part or product, such delays can stretch from days into weeks. With analysts caught up in routine simulation as well as complex matters, designers may be left waiting until they can proceed.

Productivity hold-ups are critical for any company, especially when they are in a demanding supply chain with fixed deadlines for a range of clients. One such company is DENSO Corporation. In terms of sales, the company is the second largest automotive parts and systems provider in the world, supplying nearly all major OEMs globally.

A member of the Fortune Global 500 with more than 200 consolidated subsidiaries around the

globe, DENSO works with leading brands, liaising closely with automotive partners on research and development for electric and hybrid vehicles. It also operates in other markets such as household heating equipment and industrial robots. With a commitment to innovation, the company recognized one big internal challenge. "We have an issue with long lead times for CAE in product design," comments Yuichi Kondo, project assistant manager at DENSO. "It takes time to communicate."

Streamlining workflows

A long-term partner of Siemens Digital Industries Software, DENSO uses NXTM software for design and manufacturing and Simcenter™ software for simulation. These are part of the comprehensive Siemens Xcelerator portfolio.

Across the organization, NX modules support every aspect of design from concept to manufacturing whilst Simcenter 3D provides accurate multi-disciplinary simulation of product performance. With an integrated toolset on a common platform, geometry can seamlessly pass from CAD to the CAE environment and back. The simulation model and design geometry are always associated, which enables easy updating.

This connectivity already saves DENSO considerable time that was previously spent on part translation, communication between teams and essential documentation. The obvious next question was "Why can't design teams perform some analysis on their own?"

Enabling early analysis

In answer to that, the company began to develop what it calls the NX CAD and Simcenter 3D integrated process. The first step was for the simulation team to capture repeatable processes and practices and package them up into semi-automated templates that guide designers in preparing models for basic simulation and analysis.

When designers are creating a model in NX they are now required to color-code certain critical geometry features such as narrow blends or fixed

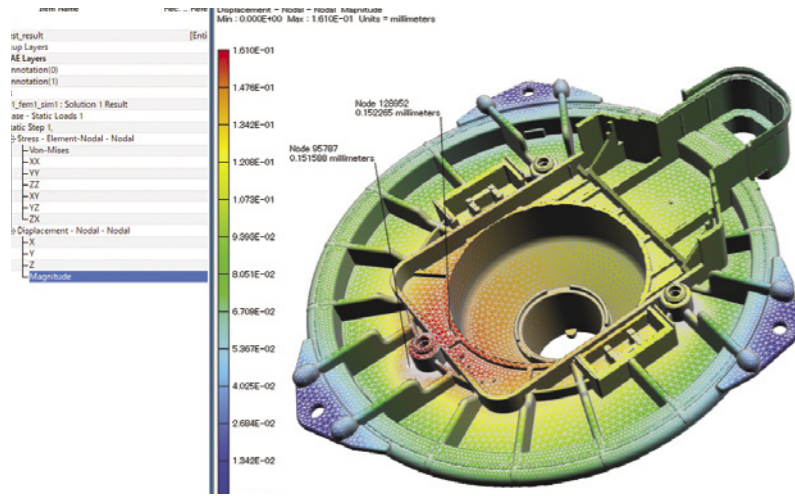

constraints. Once a designer is ready to analyze part performance, he/she applies a finite element method (FEM) template that automatically creates the FE mesh, utilizing a set of rules governed by the color-coding. This ensures a good quality mesh.

The designer then applies the sim template. This also uses the color-coding of geometry features and sets up the appropriate boundary conditions and required simulation parameters. Next, he/she simply runs the simulation model and views the results.

Because the model is already color-coded, subsequent analysis iterations are fast and easy so a designer can make geometry changes to reduce stress or improve performance then rerun the simulation without any additional work. "This is a major advantage of the NX CAD and Simcenter 3D integrated process," says Kondo.

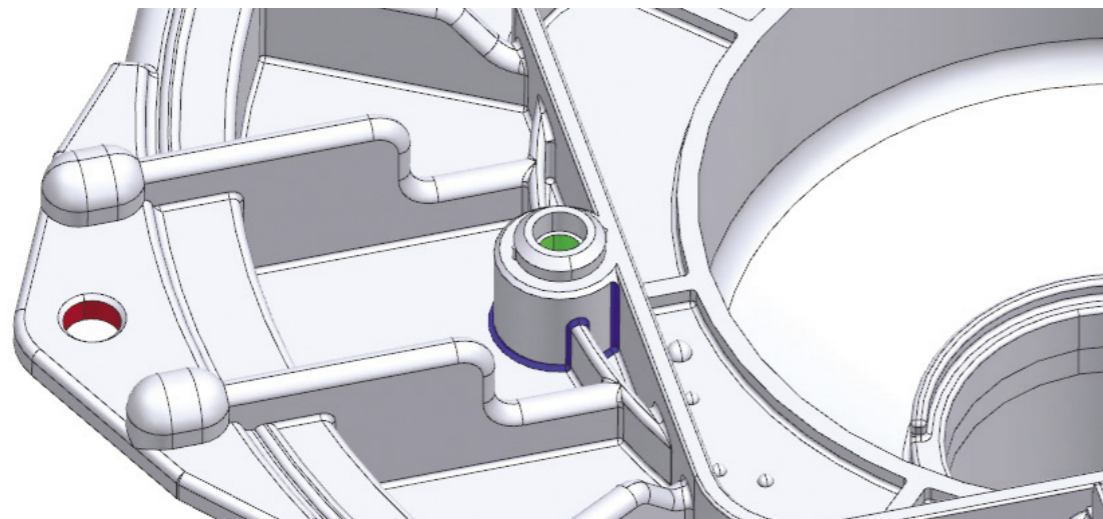

The color-coded information is part of the model's feature history and can be suppressed when design work is underway. Designers can reverse the suppression of color-coding features when they are ready to run a simulation. "This makes it very easy for designers to understand and reuse the color-code information," Kondo continues.

Simple scaling up

The Simcenter 3D and NX integrated process can also be applied to assemblies. Because each component of the assembly has color-coded geometry features, the total number in an assembly can be quite large. One early test involved preparing an assembly of over 30 components and performing a linear-static analysis. The simulation templates use the color-coding to accurately set up the mesh, boundary conditions and parameters across the entire assembly.

CAE time down by 80%

"By using the NX CAD and Simcenter 3D integrated process and CAE template, we reduced the time spent for CAE analysis by up to 80 percent," says Kondo. Analysts have also been freed up to focus on more complicated projects.

The color-coded sections are areas where, in the past, analysts would have needed to manually edit some settings when creating a simulation model. Now that all these details are captured and automated by the template, the amount of color-coding in a model represents time saved in comparison with the original process. "The larger the number of color settings, the greater the reduction in work hours," notes Kondo.

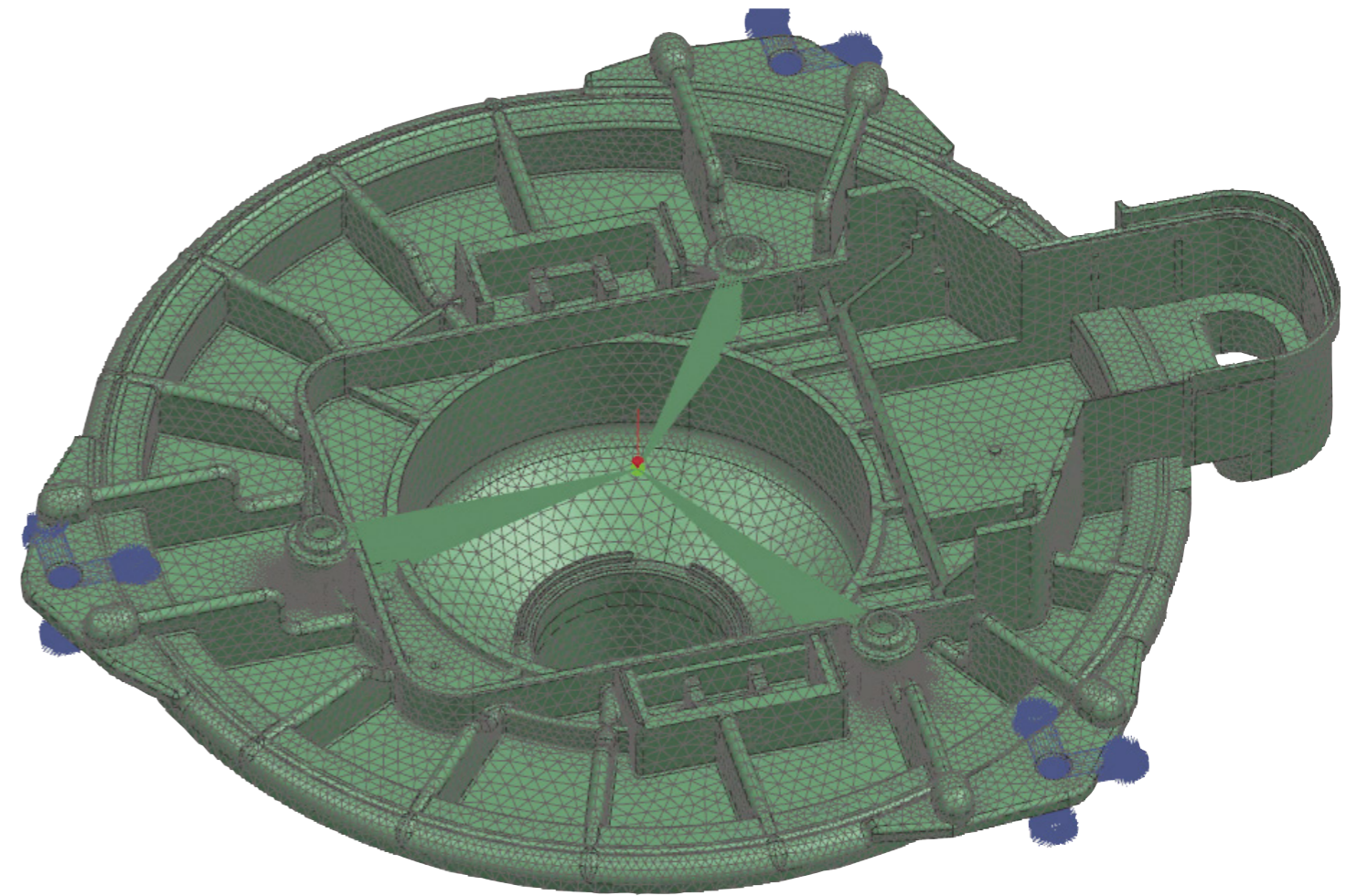

The company also noticed increased quality. Design problems are identified and corrected earlier and the potential for human error is reduced because there is less file sharing.

Creating a Teamcenter extension

DENSO uses Teamcenter® software, also in the Siemens Xcelerator portfolio, for all design data management. Looking ahead, DENSO is focused on extending the use of the integrated process into data and lifecycle management.

Before DENSO began adopting the integrated process, the master model was stored in Teamcenter, but analysts were working outside Teamcenter using a separate storage and management system. In that system, the CAD data inside simulation and the simulation data itself were not being tracked.

As a consequence, time and effort were spent exporting and importing CAD data from Teamcenter because analysts needed to make sure they were using the right geometry files for their simulations. Data related to CAD variants had to be tracked manually, with individual analysts managing their own data. If team members

changed and original data could not be located, it was often necessary to create a new simulation model.

The new proposed workflow is for all simulation data files and related templates to be saved in Teamcenter, eliminating the need to export and import CAD data every time there is an analysis.

Using Teamcenter provides an additional benefit. Model data can be viewed in the JT/JTDM data format, designed for fast viewing without the host software. JT files are small compared to the original data files they present, sometimes by a factor of 50. This enables team members who are not regular NX or Simcenter 3D users to make quick work of a design review.

A united future for design, analysis and data

On early adoption sites the traditional workflow between design and engineering analysis has been successfully streamlined, uniting these disciplines. DENSO anticipates further reductions in CAE working hours as it continues to roll out the NX and Simcenter 3D integrated process and the Teamcenter extension.

EXPLORE THE POSSIBILITIES

The height of comfort

How Renault is using Simcenter Testlab VPA to reach new levels of NVH optimization





What are the most important factors you consider when choosing a new car?

Everybody has different needs depending on their circumstances. If you have a young family, you'll probably want lots of room, for instance. Others may want something with faster acceleration or a higher top speed, although it depends which country you live in as to whether or not you'd be able to make full use of that!

Whatever your preference, you probably want a car that feels comfortable to travel in, either as a passenger or driver. And as cars become more autonomous, comfort factors are becoming a priority for many buyers.

Renault has always focused on comfort alongside performance and reliability, but recognizing its growing importance, they're utilizing the latest simulation technology to deliver the ultimate comfortable driving experience.

NVH optimization

The key to vehicle comfort is the optimization of noise, vibration, and harshness (NVH). In the past, combustion engines would mask many sounds, but with the quieter motors of electric vehicles this is no longer the case. To combat this, in the early 2000s Renault created the Virtual Synthesis in Acoustic (VISA) project to help different teams work closer together to optimize the NVH of their interacting components.

VISA allowed teams to assess NVH behavior throughout the development process and implement a modular, system-driven design methodology to bridge the gap between Renault and external suppliers.

But it was limited by the technology available at the time. For instance, there was no way of characterizing noise and vibration sources in an invariant way. It was also difficult to exchange data between testing and CAE, and there were no existing boundary conditions for the new complex hybrid-electric architecture.

Philippe Mordillat, NVH simulation expert at Renault explains that "in the end, 90 percent of the use cases we could analyze were linked to pure components weakly coupling; for instance, softly mounted and applications for low or

mid-frequency booming noise. We wanted to extend the applicability of the methods to higher frequencies such as road noise and pass-by noise cases."

Next generation collaboration

Renault's desire to continually improve their development processes led to a strategic collaboration with Siemens Digital Industries Software. Since 2016, the two organizations have been working together to improve the existing VISA platform by taking advantage of the latest simulation technology.

The vision was a holistic, company-wide process to reliably assess NVH performance of an assembled vehicle virtually, without a physical prototype. It needed to be available to any stage of development and accessible to all engineers, not just simulation experts.

To meet these requirements, Simcenter Engineering and Consulting Services, and Simcenter Test and Engineering services, collaborated with Renault engineers to leverage the capabilities of Simcenter Testlab Virtual Prototype Assembly (VPA).

Together they deployed a component-based transfer path analysis (TPA) method that could identify invariant noise sources that were previously not distinguishable. Not only does this method pinpoint the component generating the noise, but it also highlights the way the component is connected and interacts with other subsystems.

The improved tool also allows Renault to exchange key data with suppliers without risking any breach of confidentiality – no detailed specifications or geometry are shared, only curves such as

frequency response functions (FRFs) or loads. This enables both parties to better set common criteria and targets to work towards for each component.

Simulation for all

The new platform will initially be mainly used by Renault's CAE department who have an important role in making it more widely available. They will build up a database of components that is stored in Simcenter Testlab and can be easily searched and re-used in each new development. As the database grows, more engineers across the company will be able to make use of the platform to create virtual assemblies using the pre-built components. As Mordillat says, "The reason for using Simcenter Testlab VPA is to have an easy and standardized process that users can follow in their everyday activity, no matter which engineering site or vehicle model they are working on."

It hasn't taken long to see a positive impact from the new development process. "Using Simcenter Testlab VPA expanded our applications for NVH prediction by a factor of five," says Mordillat.

And it's going to keep getting better.

The next step is to integrate the new process with Renault's GREEN (Global and Rational Energy Efficiency) platform. This is another Siemens collaboration powered by Simcenter Amesim which improves the evaluation of hardware and software controls in hybrid-electric vehicles. CAE engineers will build models on the GREEN platform and then combine them in the Simcenter Testlab VPA with test-based components created by measurement specialists to build the virtual assemblies for NVH predictions.

The end result will be more accurate prediction of design modifications in the virtual environment, meaning less physical testing is required. The number of prototypes will be reduced and new vehicles with fully optimized NVH will be developed faster and cheaper.

As we progress towards fully autonomous vehicles, comfort will certainly be high on any car-buyer's wishlist. And thanks to this innovative collaboration, Renault will be ideally positioned to deliver the most comfortable vehicles of the future.

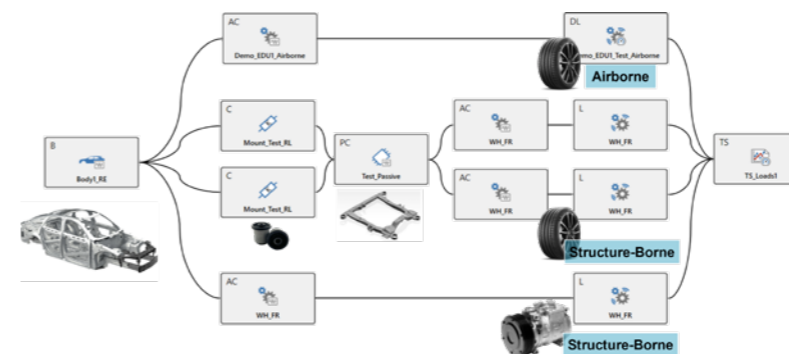



GO FASTER

High-speed and zero emissions

REGENT and Siemens collaborate for revolutionary zero-emission seaglider

REGENT seaglider expected to dramatically reduce time and cost of moving people and goods between coastal cities. Siemens Xcelerator is REGENT's fundamental design, engineering and development platform

Siemens Digital Industries Software today announced that REGENT has adopted the Siemens Xcelerator portfolio of cloud-based software and services to help pioneer a new category of vehicle called the seaglider. The seaglider is a high-speed zero emission vehicle that operates exclusively over the water to drastically reduce the time and cost of moving people and goods between coastal cities.

With 40 percent of the world's population living in coastal communities, REGENT's electric seagliders will be the first vehicles to offer safe, low-cost, high-speed, zero-emission vehicles for this segment. As a manufacturer or OEM, REGENT's launch customers span aviation, ferry, and logistics transportation operators.

The REGENT seaglider operates exclusively over the water as an all-electric wing-in-ground-effect (WIG) vehicle. It travels the sea in one of three modes—floating on its hull near the dock, foiling on its hydrofoils at up to 40 knots (kts) as it comes in and out of port, or flying above the waves at 160 kts while cruising to its destination.

When in flight, it operates a few meters off the surface of the water, relying on the ground effect phenomenon, flying on a cushion of air. It combines the high speed and comfort of an airplane with the low operating cost of an electric vehicle. Seagliders differ from past WIGs due to their hydrofoils, distributed electric propulsion, and aerospace fly-by-wire controls. These elements enable safe harbor operations, increased wave tolerance, and a comfortable passenger experience.

At the heart of its design, engineering and development toolset is the Siemens Xcelerator portfolio, which has been fundamental to REGENT since its founding in 2020.

"At REGENT we are focused on bringing a revolutionary new vehicle to the transportation market with the potential to change how both people and freight move over the water," said

Mike Klinker, CTO and cofounder of REGENT. "As our seagliders approach certification and full-scale commercial production, we need a robust, modern digital tools platform that supports the pace of our innovation cycles with the rigor to encompass a product as complex as ours. Siemens Xcelerator as a Service was a perfect fit for a digital-first startup like ours. Cloud native solutions, such as Teamcenter X, minimize administrative overhead and allow us to focus 100 percent on design, engineering, manufacturing, and innovation. Siemens' valued collaboration and the subscription model provide significant cash flow benefits that are vital to any startup."

REGENT's flagship seaglider, the 12-passenger Viceroy, will be built to the highest safety standards. It will be able to service routes up to 180 miles with existing battery technology and routes up to 500 miles with next-generation batteries, all via existing dock infrastructure. Additionally, its operation as a wing-in-ground effect vehicle above the water enables maritime testing and certification. This is an efficient pathway to entry-into-service, allowing customers to experience high-speed, zero-emission coastal mobility sooner than electric aviation options, while maintaining similar levels of safety.

"The revolution of both mobility and electrification is continuing at an exciting pace across the entire spectrum of the industry, but it's not often that the two combine with such spectacularly innovative product design to address a specific challenge like the one faced by coastal communities across the globe," said Dale Tutt, Vice President of Industry Strategy, Siemens Digital Industries Software. "REGENT is pioneering innovative high-speed coastal transportation while targeting net zero from the very beginning. Our Siemens Xcelerator as a Service portfolio is instrumental in helping them get there faster."

Siemens Digital Industries Software is driving transformation to enable a digital enterprise where engineering, manufacturing and electronics design meet tomorrow. The [Siemens Xcelerator portfolio](#) helps companies of all sizes create and leverage digital twins that provide organizations with new insights, opportunities and levels of automation to drive innovation. For more information on Siemens Digital Industries Software products and services, visit [siemens.com/software](https://www.siemens.com/software) or follow us on [LinkedIn](#), [Twitter](#), [Facebook](#) and [Instagram](#). Siemens Digital Industries Software – Where today meets tomorrow.



STAY INTEGRATED

Not your everyday racecars...

Two student teams InMotion and Ecurie Aix set a fast pace in EV innovation

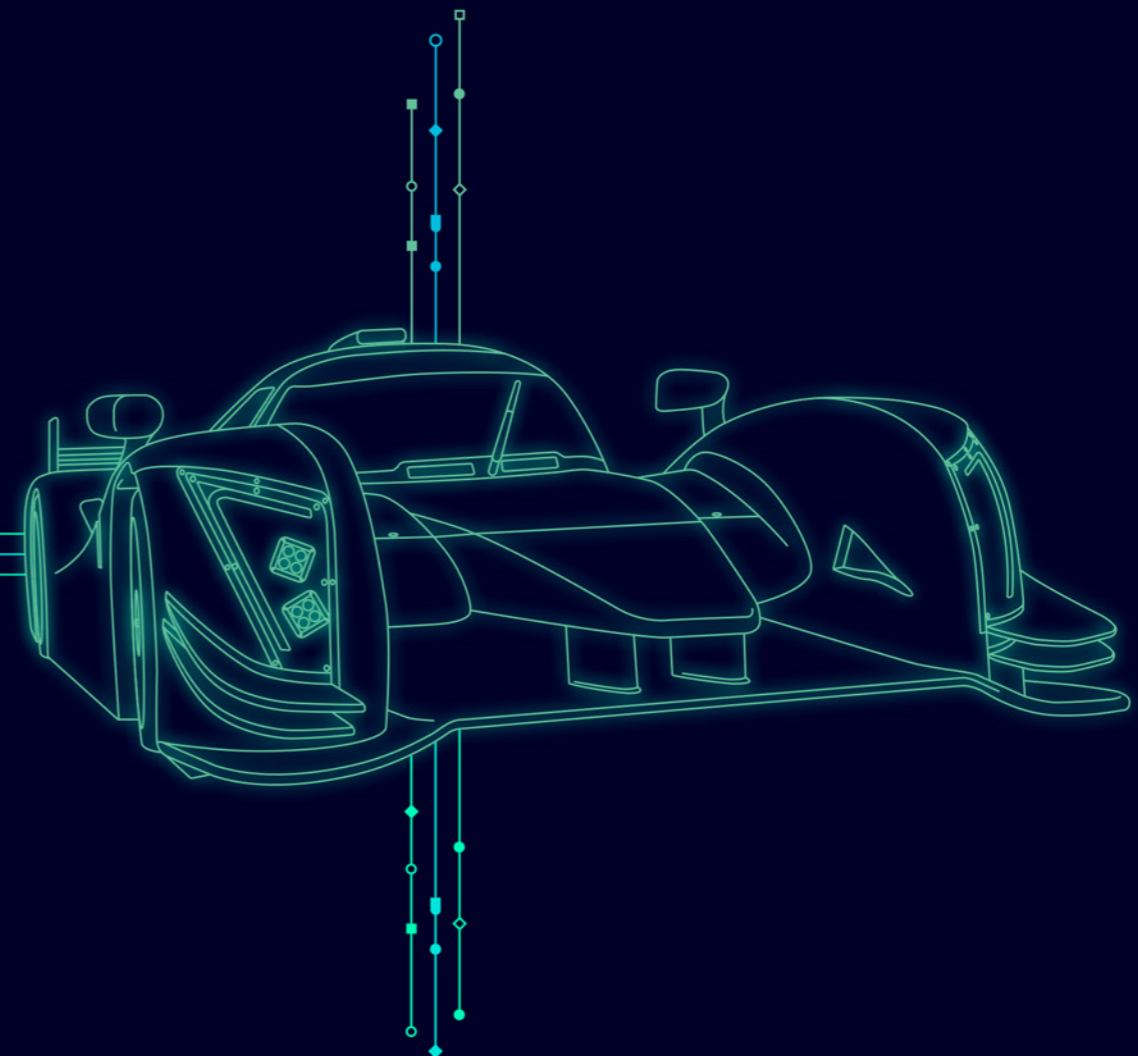



Student solar racecars zooming through the Australian Outback in the World Solar Challenge, hyper-loop prototypes competing at European Hyperloop week, student rocket launching competitions at the Spaceport America Cup in the New Mexican desert...There certainly isn't a lack of exciting opportunities when it comes to student competitions.

The popularity of student team experiences seems to be booming and rightfully so. Of course, there is the obvious fun factor. Who wouldn't want to go on a trip to Australia to race solar car technology that could possibly save the planet? Or fulfill a childhood dream as you watch your team's rocket soar off Spaceport America's launch pad?

Unquestionably the student team experience is life-changing and provides the next-generation of engineers and entrepreneurs with a solid professional skillset and exposure to new technology and ideas. Two great examples of this are the InMotion student team, associated with Eindhoven University of Technology in The

Netherlands, and Ecurie Aix, the Formula Student team from RWTH Aachen University in Germany. Both teams have gone above and beyond the call of duty, having designed and developed racing-on-the-edge-of-technology EVs in record time.

Record-breaking 12 minute fast-charging

Wouldn't we all want to drive an EV if we could fast-charge it full in about the same time as it takes to fill a tank with petrol? This is the inspiration driving InMotion. Based on the Automotive Campus in Helmond, The Netherlands, InMotion is currently fine-tuning its latest car, the Revolution. The Revolution is an all-electric Le Mans car that showcases its innovative 12-minute fast-charging technology and demonstrates its next-generation battery packs.

"We really try to innovate on the mobility side," says Martijn Scholtus, former account manager for InMotion. "We believe that fast charging is way too slow at this point and that might be a reason that people do not drive electrically. With the Revolution, we want to make the charging time as fast as possible. It is charging in 12 minutes. That's a big leap. And it's a Le Mans race car."

A decade of winning innovation

The InMotion team, which is run as a foundation that rotates students annually, practices continuous innovation. Experienced former

members meet weekly with the current team to share information and help them solve technical challenges. In over ten years, InMotion has built four successive innovative race cars including the bio-ethanol Ignition; the fastest student e-Formula 3 called the Fusion; the Vision, a more aerodynamic e-concept car; and the Revolution with its 12-minute e-charging time.

"Ten years of being a student team is quite amazing," says Ewout Timmermans, former team manager, InMotion. "This is what makes InMotion special. The people that founded it ten years ago are still on the supervisory board. People that built the first electric race car, the Fusion, are still providing us with knowledge about the Revolution. That's unique. It's about moving forward, making progress and keeping continuity on the team."

Using Siemens solutions to gain professional experience

One main focus for InMotion recently was to professionalize the team. The students wanted to take it up a notch and start performing like a real racing team. InMotion turned to Siemens Digital Industries Software to help make this a reality.

"Siemens is a key partner in making this happen as they provide us with all of the software to design, build and engineer the car," Timmermans adds. "It is necessary to work with really good software. Siemens provides this same software suite to Formula One as well. So, at InMotion, we're working with the same software as the pro teams and that is really allowing us to push our design to the limit. As a result, we have an amazing race car in the garage that is an enormous piece of engineering. This is really unique."

An innovative mindset

The team built a comprehensive digital twin of the Revolution and its systems using Siemens NX software for detailed computer-aided design (CAD) work and various Simcenter software tools, like Simcenter STAR-CCM+ software and Simcenter 3D software for advanced engineering tasks. And with the team's innovative mindset, it isn't surprising that InMotion was one of the first student teams to fully integrate Teamcenter software into the process to leverage the right data from the digital thread of the Revolution.

"People think that we just start designing something, which is not true. We designed the Revolution as a team and this process comes with a lot of requirements, preferences, ideas and constraints," says Thomas Kuijpers, former technical manager, InMotion.

Leveraging the digital thread

Working in a digital thread with a digital twin was a new concept for some of the engineers on the team. Old-school tactics, like prototyping and on-the-fly troubleshooting are now a thing of the past for the new generation of InMotion engineers.

"I think for most of the engineers, it was a true eye opener that you can work in this detail and represent advanced design and engineering performance this accurately in a virtual world," explains Kuijpers.

The InMotion student team is quick to recognize that getting everyone up to speed on all the Siemens solutions was far from an out-of-the-box experience. They had help from cards PLM Solutions, a Siemens Platinum Smart Expert Partner, based in Best, the Netherlands.

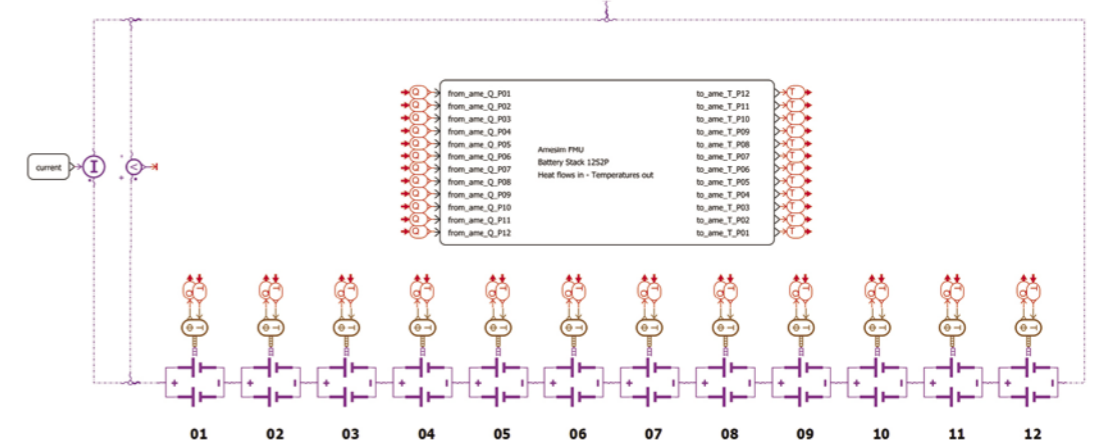

Check out this Blog

“The consultants from cards PLM were always quick to respond and point us in the right direction when we got stuck,” explains Kuijpers. “Another bonus about Siemens, especially for students, is the Siemens Xcelerator Academy. Most of us had already followed courses online with the university, but once we started working as a new team, we had more access to specific material and tutorials. This was very useful for us.”

Concludes Scholtus, “The most prestigious race is the 24 Hours of Le Mans. Our entire team dreams of racing there with this technology. If it works at the 24 Hours of Le Mans, then it’s going to work everywhere.”

Watch Now

And down the street in Aachen, Germany

Head about 100 kilometers south from Helmond to Aachen, Germany, the home of RWTH Aachen University and one of its many university student teams, [Ecurie Aix](#). Practically a pioneer in Formula Student racing, Ecurie Aix is named for the area’s racing heritage. Just across the border is the famous Belgian track, Spa-Francorchamps, home circuit to the Belgian Ecurie Francorchamps racing team, a mainstay in the early days of F1 and Le Mans in the 1950s. In honor of this, Ecurie Aix

combines the French word for racing team, Ecurie, with Aix, as in Aix-la Chapelle, the French name for Aachen.

Formula Student is a worldwide competition with more than 500 academic teams designing and developing their own car according to Society of Automotive Engineers (SAE) or the Formula Student Germany (FSG) regulations. The goal of the competition is to have the student teams design, manufacture and test a race car in one year. Like other teams, Ecurie Aix team has transitioned from the ICE engines it started with in 1999 to EVs. This past summer they raced with their 10th fully electric vehicle as well as taking baby steps into the world of AV with a brand-new vehicle, the eax01, better known as Aileen.

The secret is the battery

Of course, the trick to winning a race is all about the engine or, in the world of EV, the battery. Ecurie Aix wanted to improve the thermal and electric characterization of their battery packs. They understood they needed to combine several disciplines to manage the complexity and turned to their partner, Siemens, to help execute “Batterie Aix”, an engineering project which combined experiments, systems simulation and computational fluid dynamics to optimize the battery thermal management, taking into consideration scalability, re-usability and future enhancements.



Using Siemens solutions to gain insight into battery usage

During the Batterie Aix project, the students determined how to characterize the battery cells and optimally integrate the batteries into the vehicle to meet their performance expectations, range, and design requirements. They also needed to correctly dimension the cooling system so it would fit safely.

“We needed Siemens’ solutions for battery and thermal simulations; modeling the battery and its behavior was a new field for us,” states Thomas Nyhues, student engineer, Ecurie Aix.

Onwards to Batterie Aix

Instead of using a complex battery model to generate data, they conducted real-world experiments at the Institute for Power Electronics and Electrical Drives (ISEA) at the RWTH Aachen. Using a multi-disciplinary approach for the electrical and thermal simulation, the team combined experiments in systems simulation and CFD, co-simulating in Simcenter Amesim and Simcenter STAR-CCM+ respectively. This experimental simulation approach resulted in valuable insights into battery usage.

[Read the full technical story here](#)

Success thanks to Siemens

The team is quick to credit the expert technical support provided by Siemens as a key success factor in this project. Like other Siemens-sponsored student teams, Ecurie Aix could access online learning material from the Siemens Xcelerator Academy and [Siemens Support Center](#). This was enhanced by in-person expertise from the Siemens.

Nyhues adds, “We ran into some problems with coupling the software and using it for the first time, but Siemens’ support team always offered us a solution.”

Once the battery cooling system was correctly simulated, the team used the model during the vehicle development process. For example, reducing the size and weight of the cooling system gave Ecurie Aix an advantage over other teams.

“The battery identification tool in Simcenter Amesim saved us a lot of time,” continues Nyhues. “You just put your data into a toolbox and get an accurate battery model.”

Concludes Nyhues. “Siemens enabled us to get into the software and tackle any problems that arose during the project. I am still overwhelmed by the motivation of the Siemens team. It felt like they were part of our team and had the same goal.”

Following their most successful summer season to date in 2021, Ecurie Aix pushed the bar a step higher during the 2022 summer racing season and competed with a brand-new vehicle, the eax01, better known as Aileen. Aileen is an autonomous EV that can also be driven by an actual driver. Meeting the latest standards proved to be quite the challenge. Despite the fact that Ecurie Aix had to compete all season with only Aileen’s front-wheel-drive functional and had issues competing in the autonomous disciplines, the team was happy with the overall racing results, which included winning the Efficiency trophy in Hockenheim, Germany.

Both the InMotion and Ecurie Aix teams are looking forward to exciting EV racing experiences in the near future. And, at Siemens and Simcenter, we are just happy that we could help.

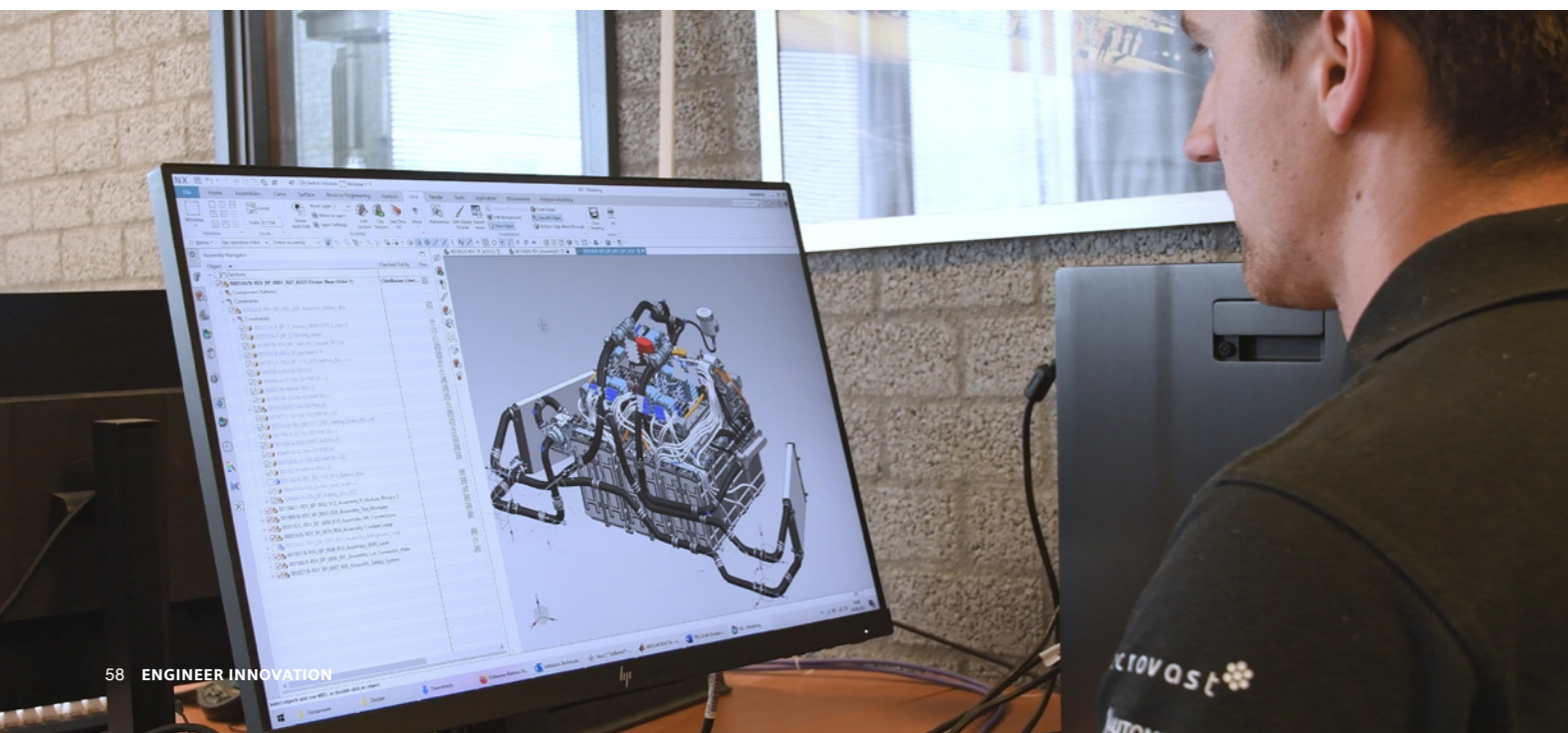



STAY INTEGRATED

Building ships in the clouds

Improving vessel design with Simcenter Cloud HPC

Most industries are under growing pressure to reduce their environmental impact and shipping is no exception.

From 2023, the International Maritime Organization (IMO) requires all vessels over 400 gross tons to undergo measurement of the energy efficiency design index (EEXI). This helps to identify ways to improve fuel efficiency – the less fuel used, the fewer harmful emissions are generated.

But calculating and improving EEXI is far from straightforward. It requires detailed analysis of a ship's hydrodynamics and propulsion systems, which takes up considerable time and resources.

DNV Maritime Advisory provides technological expertise to shipbuilders and shipowners to help them meet this challenge and many more. And simulation is key to solving these problems in the most efficient way.

Real-time simulation

Cosmin Ciortan, principal specialist at DNV Maritime Advisory, says there has been a big push towards EEXI compliance recently. "CFD simulation is the only way that this can be addressed, especially for existing vessels where towing tank models or test data are not available," he explains.

They are also involved in many projects that require aerodynamic analysis of ship superstructures with a high level of geometrical complexity.

Ciortan and his team use Simcenter STAR-CCM+ for much of their simulation work due to its multiphysics capabilities. "We never find ourselves limited by the physics and complexity that we can model," he says. "One of the things we like most about the software is the ability to see what is happening with a simulation in real time. If something is wrong with the setup, it becomes much easier to find."

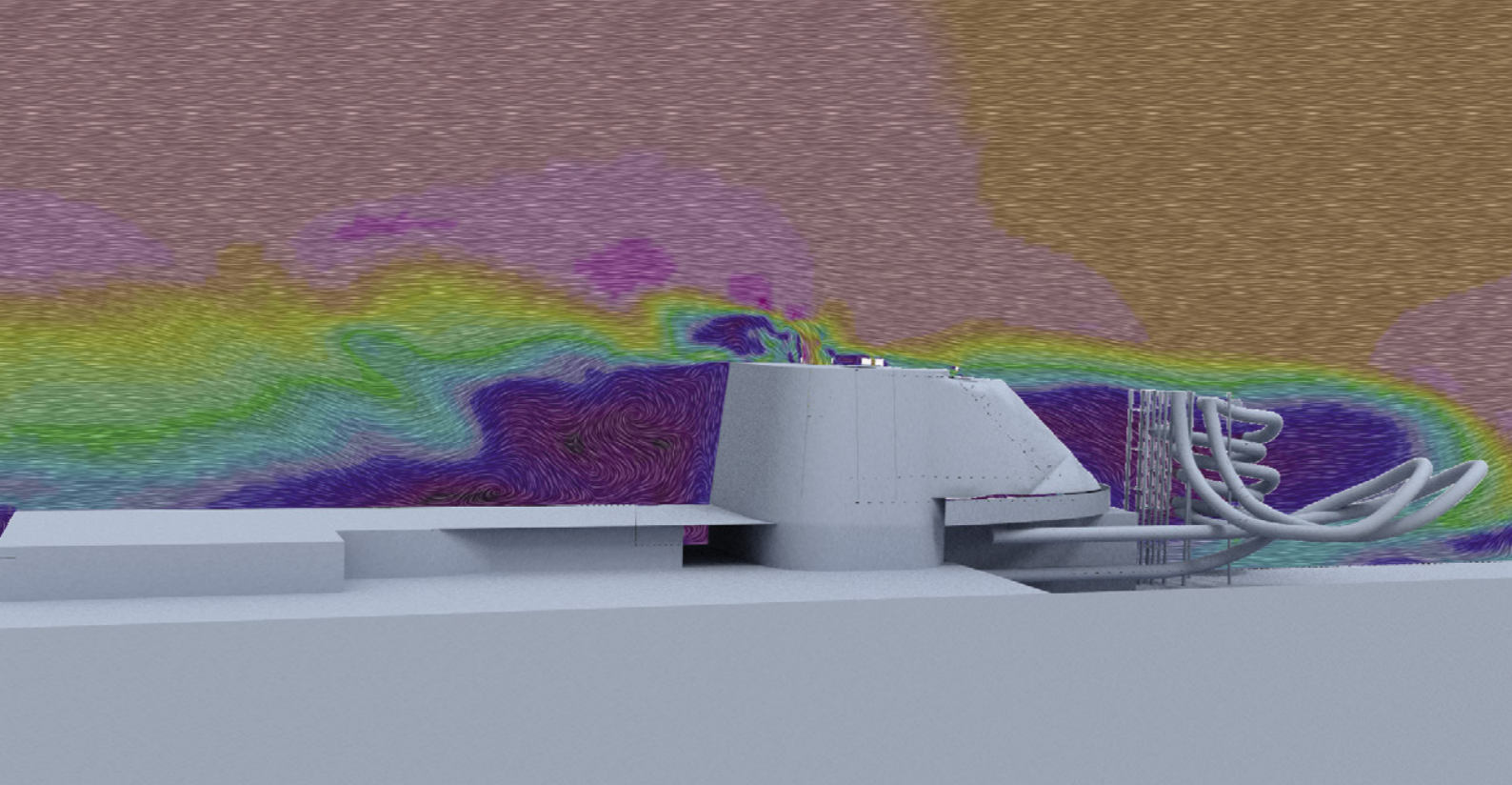

Saving time and money

Over their lifetime at sea, ships are subject to changing environmental conditions that can affect their performance. DNV Maritime Advisory are often brought in to troubleshoot issues that have come up or evaluate modifications designed to improve performance.

This is where simulation comes into its own as it's much cheaper and faster than testing with physical models. And it allows for full scale virtual models using more realistic wave and wind conditions than could be created in a test environment.

Ciortan references one particular issue that came to his team: "We were contacted by a ship owner who had found that, under certain conditions, exhaust gases were being drawn into HVAC intakes. This is a serious safety concern and time was of the essence to understand the problem and find a solution."

But taking a commercial vessel out of service to undergo engineering work is incredibly expensive and disruptive. To minimize this downtime, Ciortan's team reproduced the scenario in Simcenter STAR-CCM+ and confirmed they were seeing the same problems as the real ship. They

then worked through several ideas that could remedy the issue with the least amount of engineering work and that could be done without having to take the vessel to a shipyard. They identified a potential solution that involved extending the height of the pipework inside the funnel and then had to work out how to get all the necessary materials in place without shipyard facilities and cranes.

They worked through several options with the customer, running simulations that covered the problematic range of conditions, including different wind speeds, directions, and engine load conditions with associated exhaust discharge rates.

Powered by the cloud

All these calculations took a significant amount of computing power and needed to be completed as quickly as possible – faster than the existing on-premise resources that DNV Maritime Advisory had. So they made use of Simcenter Cloud HPC, a turnkey solution for running CFD simulations on the Amazon Web Services (AWS) cloud, direct from inside Simcenter STAR-CCM+. This allowed them to run more simultaneous simulations than they could previously, meaning they could reach the ideal solution within the short timeframe

demand. "I don't think we could have turned the project around as quickly as we did without Simcenter Cloud HPC," says Ciortan. "And it really delivered – we had a solution and a happy customer at the end."

"The other great thing is it allows us to scale our resources up or down as needed," Ciortan goes on. "Our simulation workload is often unpredictable. There will be times where we have an extremely heavy simulation to run and we need more resources fast. As Simcenter Cloud HPC runs on preconfigured hardware it's quick and easy to use. The simulations start immediately so we know when we will get results and we don't need to worry about how it works in the background."

It's simply not cost-effective for organizations such as DNV Maritime Advisory to keep all the resources

and licenses needed for the biggest projects on-premise. There would be too much time when they're not being fully utilized which would increase the cost of all their smaller projects. So, by having their own HPC cluster for most work, and then scaling up when necessary with Simcenter Cloud HPC, they can deliver projects in the most efficient way, keeping costs down for customers.

And for smaller companies working in simulation there is no longer a need to invest in their own HPC cluster. It will often be cheaper to run everything on Simcenter Cloud HPC, making it much easier for new companies to get started and grow without having to find significant funds to invest in hardware.

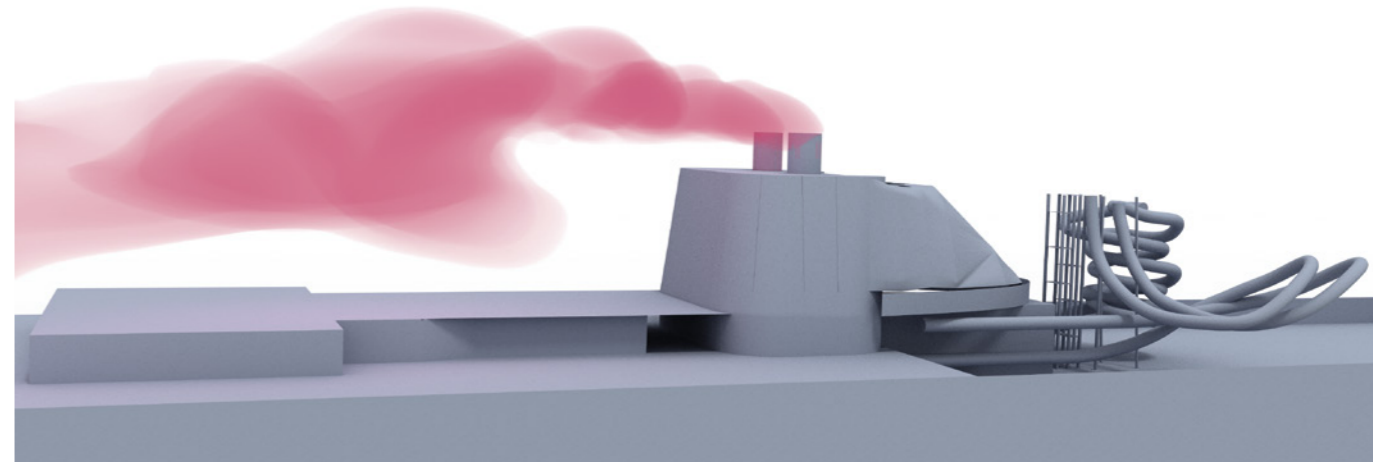
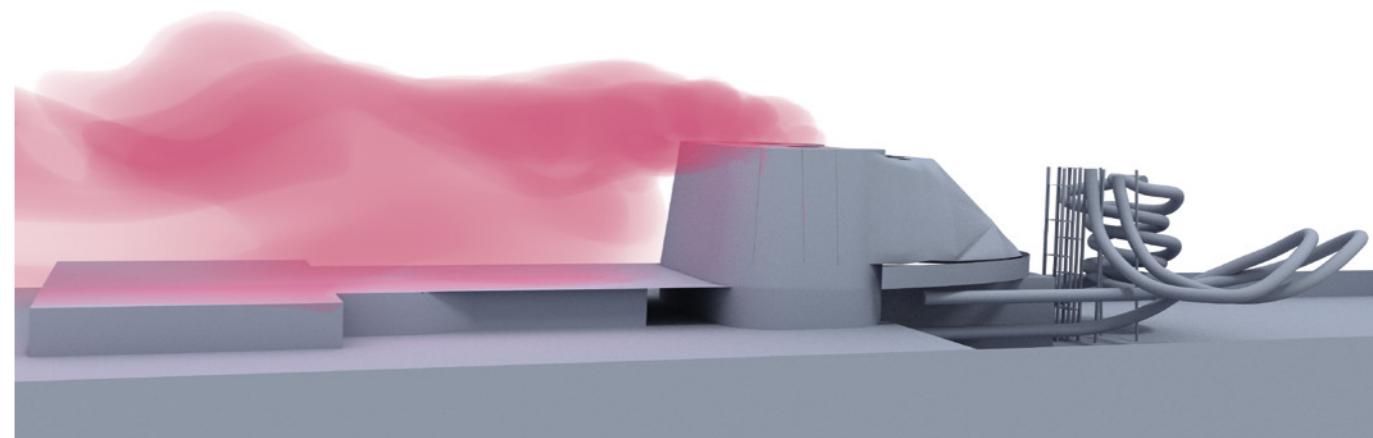

STAY INTEGRATED

Electromagnetic compatibility and **aircraft safety**

Streamlining safety design and certification with the digital twin

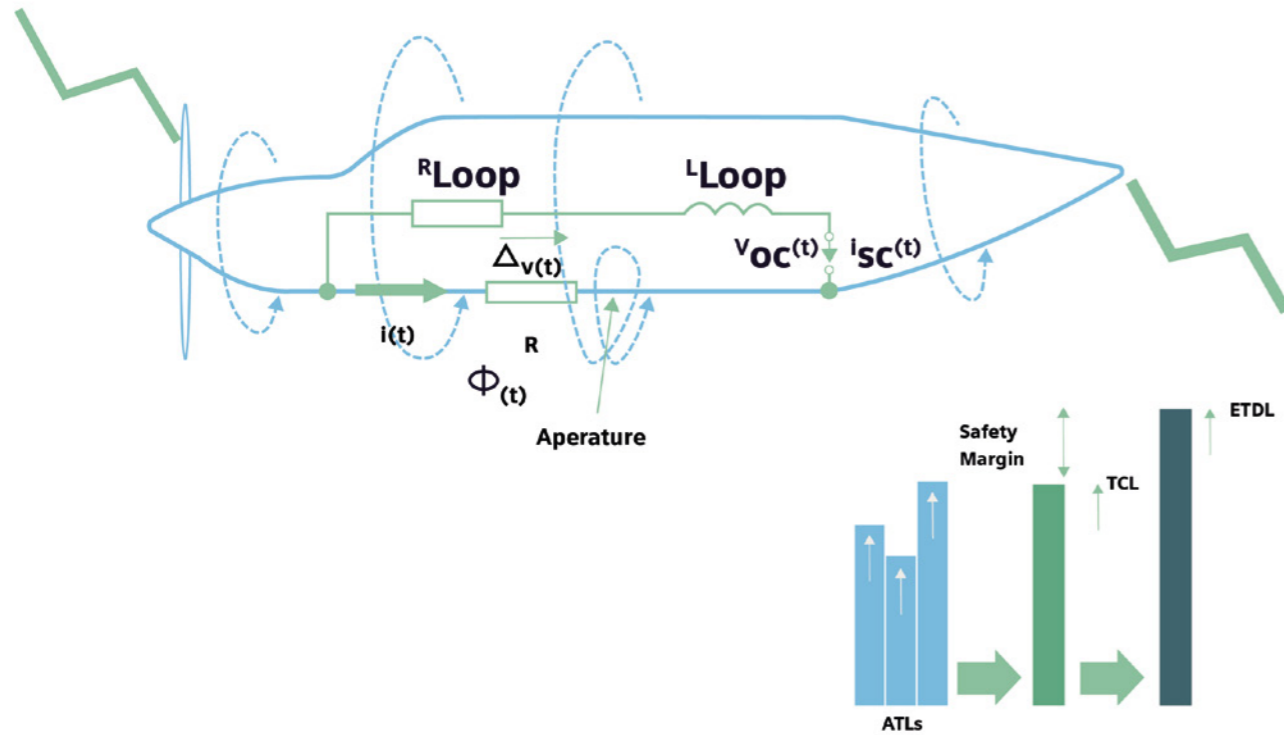

Aircraft technology is changing rapidly. Electrical and electronic devices are replacing mechanical systems in almost every area of aviation. But the increase in electrification brings with it an increasingly complex and more severe electromagnetic environment.

More external and internal radiating sources are present than ever before. These include higher power levels of wanted and unwanted emissions; extensive use of materials with reduced shielding effectiveness; and electronic devices replacing mechanical and hydraulic flight controls.

High-intensity radiated fields (HIRF) and indirect effect of lightning (IEL) have the potential to be catastrophic for aircraft. For example, electrical and electronic devices that perform safety-critical functions may be damaged by lightning strike or radiation, as well as by general electromagnetic compatibility (EMC) issues.

Engineers need to implement robust, efficient processes for high-fidelity EMC analysis to deal

with IEL and HIRF, and ensure that aircraft achieve certification and guarantee passenger safety.

Use of a digital twin is enabling aeronautical manufacturers to identify and address potential electromagnetic issues early in the design process, before physical prototypes are built, and therefore reduce expensive and time-consuming testing.

Lightning effects and radiation

When a lightning flash strikes an aircraft, the conduction of the electrical currents can have direct effects, such as the deformation of metallic components or melting of cables, and indirect effects.

Indirect effects of lightning (IEL) refer to electromagnetic interference in electrical or electronic equipment, in particular equipment that belongs to systems or subsystems that perform critical safety functions.

To obtain IEL certification, aircraft designers must be able to show that the aircraft equipment is able to withstand the potential impact from IEL. Specifically, that the equipment transient design levels (ETDLs) exceed the maximum of the actual transient levels (ATLs) by a safety margin established in the certification plan agreed with certification authorities.

High-intensity radiated field (HIRF) effects and regulations

External electromagnetic radio frequency (RF) fields can penetrate an aircraft structure through specific points of entry (such as apertures, gaskets, materials with low-shielding effectiveness) and may couple with a cable harness or directly interfere with equipment.

To gain HIRF certification, aircraft designers must demonstrate HIRF immunity – that the aircraft systems and equipment (and, in particular, safety-critical equipment) are able to correctly perform their functions in the presence of any electromagnetic environment generated from external RF sources such as radio, television or radar emitters.

Challenges in creating an accurate model

Certification authorities have recognized numerical analysis (simulation) as an option to support IEL and HIRF compliance. However, there are significant challenges in modelling the highly complex electromagnetic environment of an aircraft. These include:

- **Wide frequency range of analysis**
Simulations must be performed on a wide frequency range – from direct current (DC) to 10MHz for IEL and from 10KHz to 18/40GHz for HIRF.

Therefore, several physical regimes must be managed from simply conductive (DC), skin-effect, resonance regime, to high-frequency scattering. This requires a multi-method approach – full-wave, asymptotic and power balance modeling tools.

At low frequencies, common low-frequency breakdown and ill-conditioning problems must be addressed. At high frequencies, where the platform is electrically large, the huge number of mesh elements requires efficient computation methods to reduce random access memory (RAM) usage and overall computational time.

- **High level of accuracy required**
Resistance and admittance values, especially at very low frequencies, can be of the order of a fraction of ohm. So, for the simulation to be effective, it must create an extremely accurate high-fidelity model.
- **Wide range of physical observables to be computed**
Methods are required for computing observables such as bundle currents, electric field levels and $V_{oc}(t)$ and $I_{sc}(t)$ transients at equipment pins.

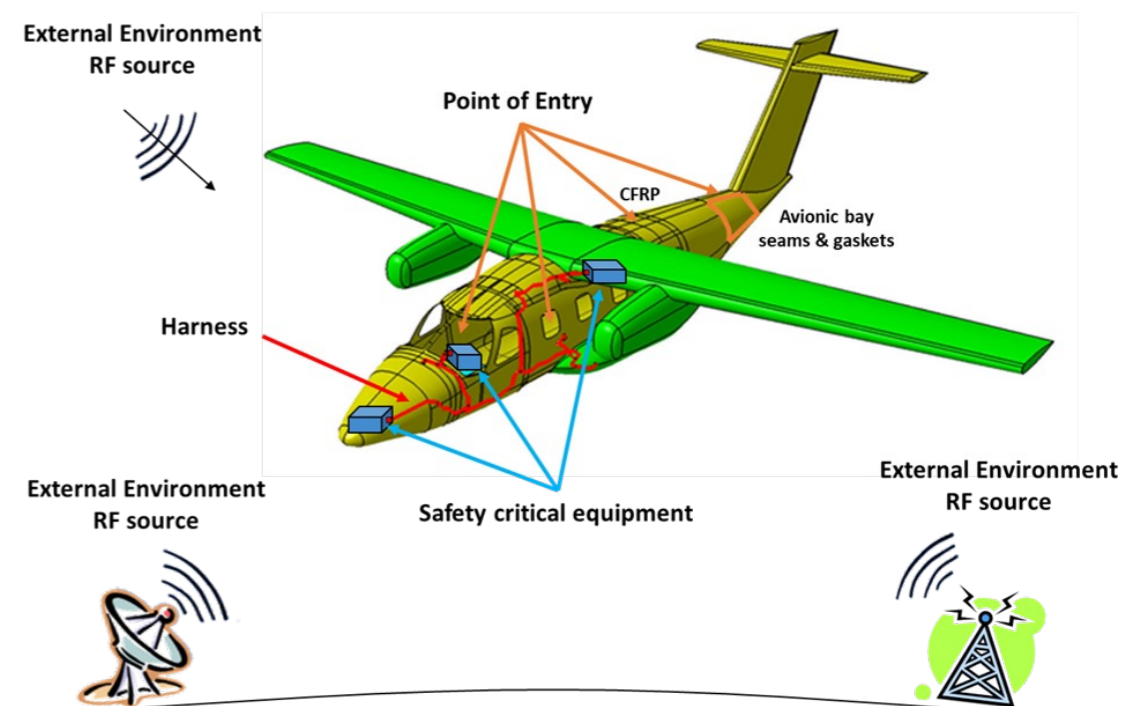

Using Simcenter to create a high-quality digital twin

The team at IDS, a strategic partner of Siemens Digital Industries Software, is using Simcenter to meet the complex challenges of aircraft electromagnetic (EM) modeling and simulation.

Specific capabilities of the Simcenter enable the team to economically perform analyses and find solutions, allowing the aircraft engineers to investigate and check different system configurations from the earliest design stages forward.

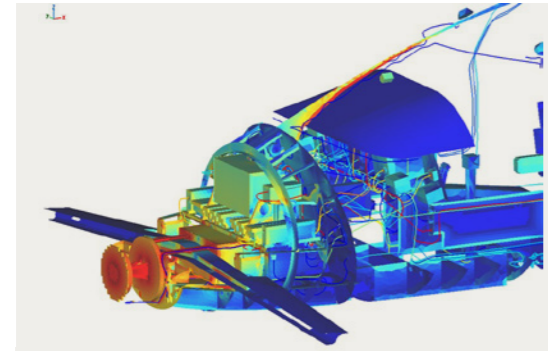

Integrated CAD and meshing tools for high-fidelity modeling

Meshed models are directly derived from detailed CAD models, minimizing the need for simplifying electromagnetic analysis. Thus, using the Simcenter, multiscale meshes composed of millions of elements can be generated and managed rapidly and efficiently.

The fundamental technology of Simcenter applied to this use case is based on boundary elements (the method of moments) and hence only requires surface meshes. This substantially reduces mesh sizes compared to other methods like the finite element method (FEM).

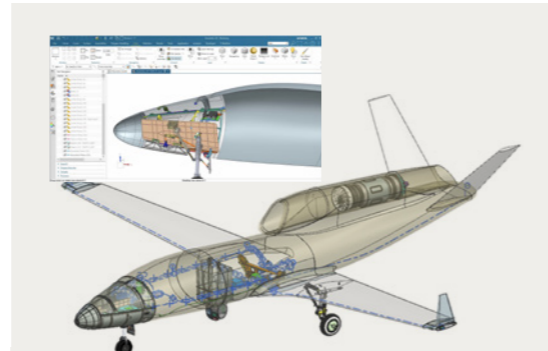

Seamless interface to electrical CAD tools

Using Simcenter, the team is able to automatically import cable harness models from electrical CAD tools such as Capital™ software, Siemens' harness engineering software.

This includes harness architecture and 3D routing, bundle composition, cables cross-sections, cable jackets and braids, junctions, loading terminations and much more. They are then translated into models suitable for hybrid 3D electromagnetic MTLN simulation.

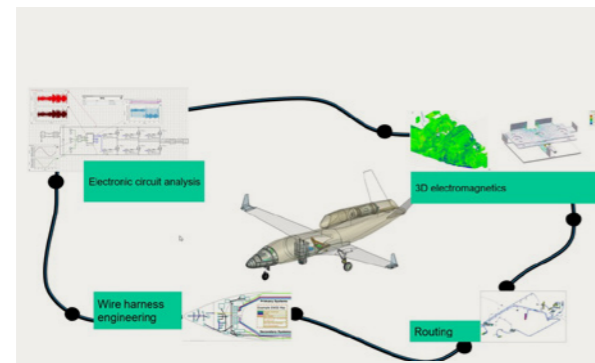

Multiple modeling formulations for aeronautical materials

Typical aeronautical materials (metallic, composite, engineered) are managed with modeling formulations such as impedance boundary condition (IBC), thin sheet and neighbourhood impedance boundary condition (NIBC).

Complexity is reduced by basing them on equivalent parameters such as shielding effectiveness for penetration problems, or surface impedance or transfer impedance for scattering/induced current problems.



Component modeling based on equivalent representations

Where detailed electrical and geometrical information is not yet available in the early stages of development (because of supplier proprietary data or because of a preliminary development phase when only the requirements of the components have been decided), components can be modeled based on the defined requirements and equivalent representations.

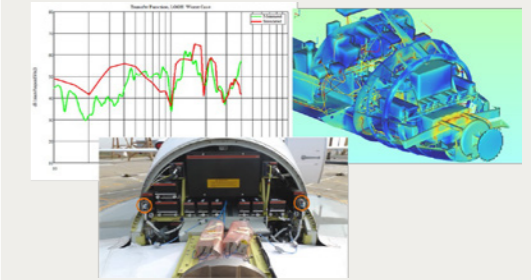

Mathematical formulations based on state-of-the-art algorithms

Complex mathematical formulations are required to eliminate low-frequency breakdown, carry out high-fidelity modeling and accurately represent the skin-effect while maintaining low-numerical complexity models.

With Simcenter teams can employ a wide spectrum of state-of-the-art algorithms, including S-PEEC, to extend the standard method of moments to very low frequencies (from MHz down to DC), and an adaptive frequency sampling algorithm which reduces the number of frequencies to be evaluated.

Safety design and certification with the digital twin

Use of a high-fidelity digital twin is helping aircraft engineers gain a thorough understanding of the new electromagnetic environment of aircraft, and develop effective solutions to potential HIRF and IEL issues before physical prototypes are built. This reduces expensive and time-consuming testing and helps to make aircraft design and certification faster and more efficient.

In addition, the digital twin enables engineers to front-load the design of critical components in the product development lifecycle. This facilitates the adoption of new, state-of-the-art electrical and electronic technologies, in turn helping to secure more sustainable solutions for air travel and maintain flight safety.



The digital twin enables engineers to front-load the design of critical components in the product development lifecycle. This facilitates the adoption of new, state-of-the-art electrical and electronic technologies."



GEEK HUB

When science meets art – sound and vibration of carillon bells

By Frank Demesmaeker

Any idea what tower bells have in common with Siemens? There are at least 3 links, so please keep reading to discover all of them.

An obvious one to start with: when a bell rings, it vibrates and produces sounds. This is exactly what we do with our Simcenter solutions: measure and simulate sound and vibrations.

A less known fact is that Siemens also sponsors visual arts, music and cultural education. Check out the website of [Siemens Arts](#) to learn more!

But my favorite link is the fact that Siemens co-sponsored the Peace Carillon close by the Leuven office.

Hold on – “a peace carillon, what is that?” – I hear you think.

Peace and Reconciliation

A [carillon](#) is a musical instrument, consisting of tuned bells in different sizes. It is played via a central baton-type keyboard. The bells are often located high up in the church or abbey tower, so that people in the city can enjoy the music played. If you have not been to Belgium or the Netherlands, chances are big that you have never seen or heard a carillon.

OK, but what is a peace carillon?

Close to the Leuven office of Siemens, there is the beautiful [Park Abbey](#). It is one of the best preserved abbey sites in Western Europe.

In 2018, the construction of a new carillon started, consisting of 40 newly cast bells. This carillon is an exact replica of the original one that was destroyed in a fire during the First World War. 100 years after they faced each other as enemies, the city of Neuss in Germany and the city of Leuven decided to recreate the carillon. Doing so, they “connect through culture what was once separated by fire”. Hence the name [Peace Carillon](#). It symbolically played the first time on November 11 2018. This is exactly 100 years after the end of the First World War.

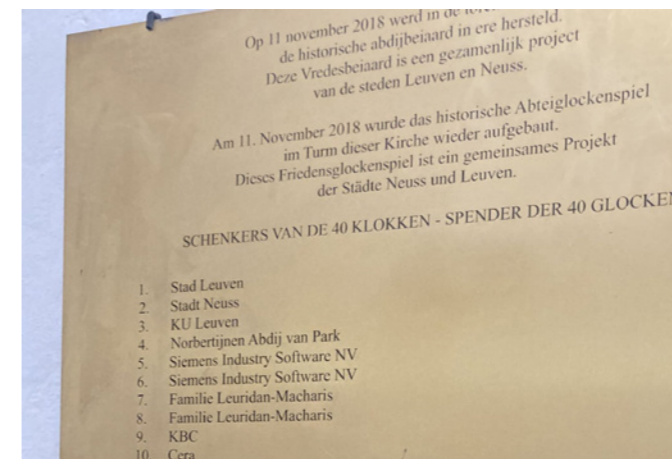

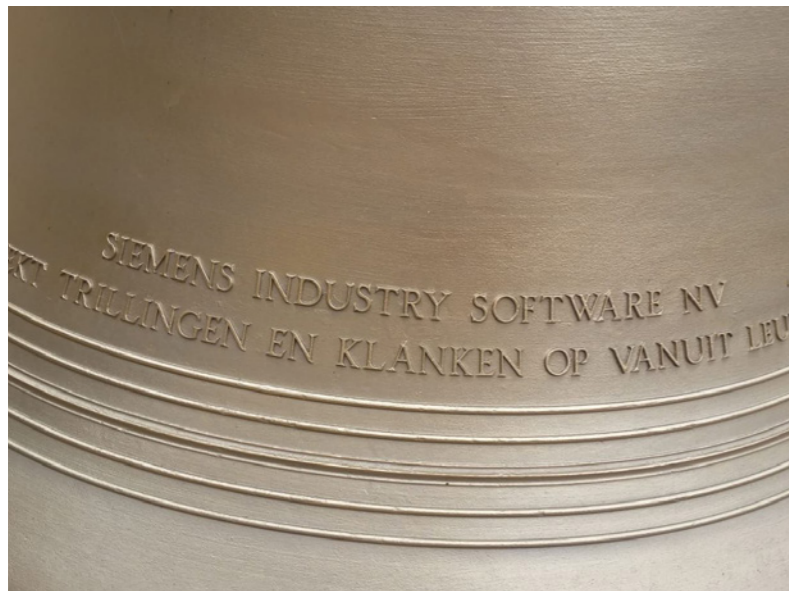
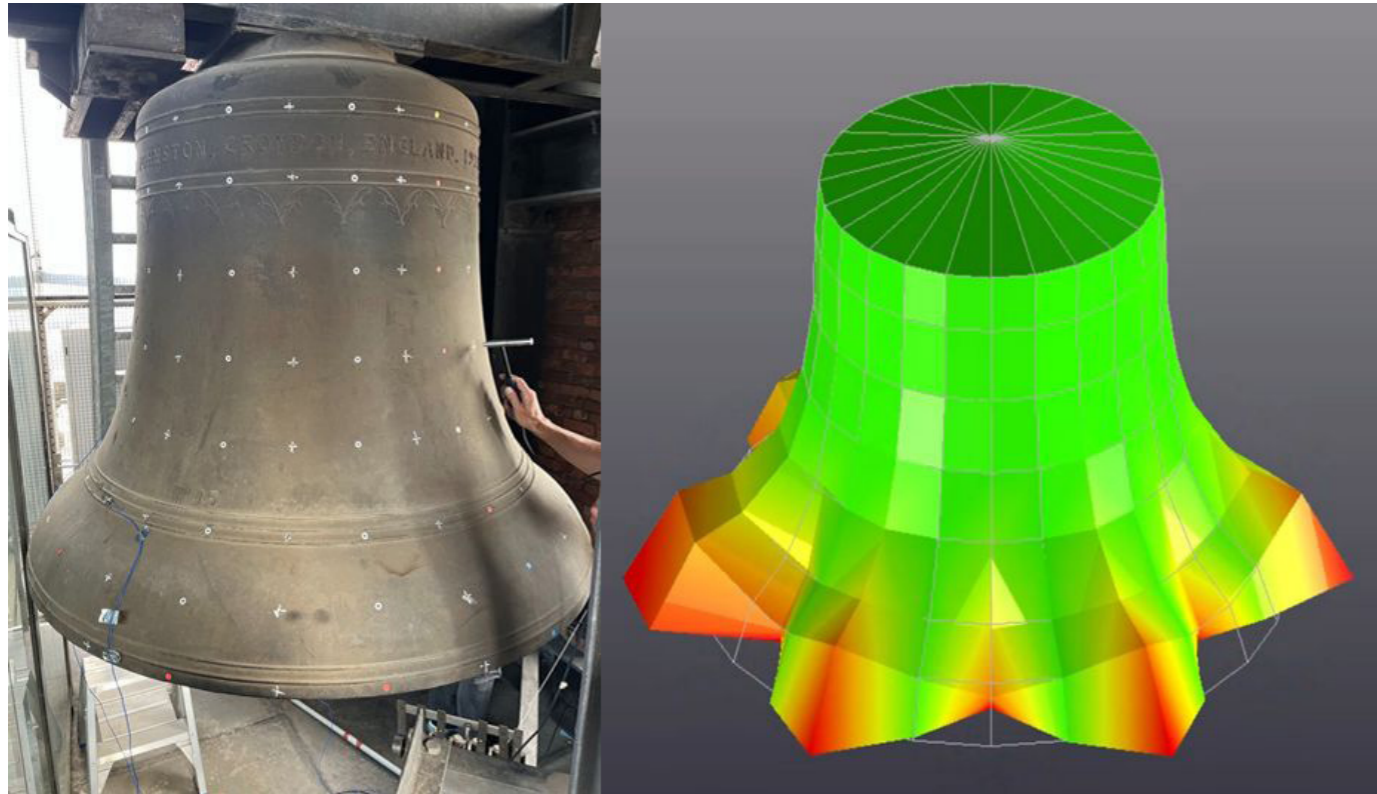

The investment of 500.000 euro was partly possible thanks to crowdfunding and sponsors. As a good neighbor, also Siemens (Industry Software NV) and Jan Leuridan (formal CTO/CEO at LMS International and Siemens Industry Software) sponsored a total of 4 bells.

So there is my 3rd link: "Siemens awakening sounds and vibrations from Leuven" as mentioned on one of the sponsored bells.

Sound and vibrations of carillon bells

As an engineer living in the shadow of the abbey, I could not resist taking it one step further.

So here is the last link: I decided to measure the sound and vibration patterns of the carillon bells.

Using the [Simcenter SCADAS XS](#) and the binaural headset, I first measured the acoustic frequencies at ground level.

Binaural recording of the Peace Carillon

As expected, those bells create a spectrum with very distinct frequencies. Traditional instruments (like strings on a guitar or an organ pipe) produce a sound spectrum based on harmonics. However, a bell is much more complex. Its typical curved shape and varying thickness generates different overtones, which are not always a multiple of the base frequency. A bell-founder can create the specific "timbre" of a bell by tuning the combination of base tones and (non-harmonic) overtones.

Harmonics and other overtones

This audio spectrum is caused by the vibration and deformation of the bell when hit by a clapper or hammer. This bell vibration is a combination of different deformation patterns at distinct

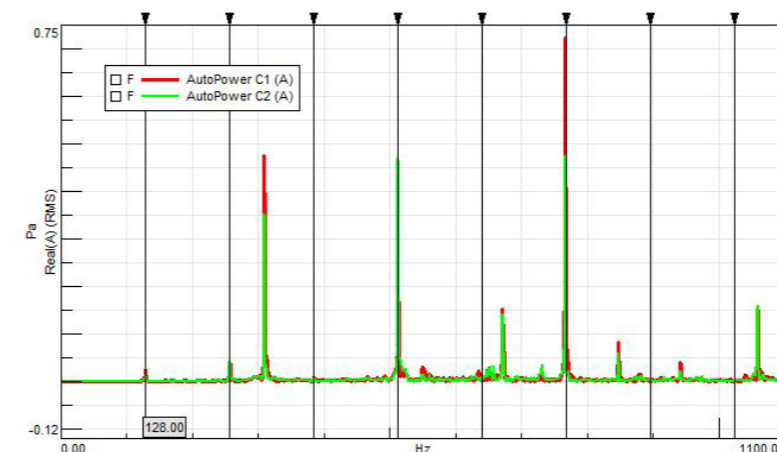

frequencies. Those deformation patterns are called the eigenmodes of the bell structure.

Our goal was to decompose this complex deformation and visualize how the bell deforms at each of the distinct frequencies. This is the process of [modal analysis](#). We artificially excite the bell by use of an impact hammer, and measure the vibration response at the surface of the bell.

Due to practical reasons and better accessibility of the bells, we moved to another carillon. Luckily Leuven has many of them. We decided to climb the 289 steps of the [Library tower](#) in the center of the city!

Climbing up the tower and hitting the bell

Climbing up the stairs to reach the bells is a challenge by its own. Needless to say I was happy that I did not have to carry any heavy measurement equipment with me. The pocket size [Simcenter SCADAS XS](#) is perfectly fit for this job. As a true sound and vibration analyzer, it can handle both the acoustic tests as well as the vibration tests. Once up there, we selected one of the bells: with a diameter of 1.6m and a weight of about 2.5 tons not even the biggest one!

In order to visualize the distinct vibration patterns or mode shapes, we performed an impact test in combination with our [Simcenter modal analysis](#) solution. To get accurate results up to 1200Hz, we measured at 7 different heights and on every 15 degrees over the total circumference – a total of 168 measurement locations.

Instead of using 168 accelerometers to measure the responses, we used the roving hammer method. Placing 4 reference accelerometers spread over the surface, we now "only" had to hit the bell with the hammer on 168 locations.

For each location we took 3 averages. As the decay of the bell is quite long, we had to wait 10 seconds between each hit. Features like automatic overload and double hit detection and audio feedback to go to the next measurement point, made our task easier and allows for a one-man operation. All in all, it took us a full afternoon to do the modal impact test.



Hitting the tower bell

Vibration patterns of the bell

Right after hitting for the 504th time, the Simcenter modal analysis processes the complete set of frequency response functions (FRF's). In a matter of seconds, the individual mode shapes show up, still high up in the tower. As beautiful as the astonishing view over the city of Leuven was, also the mode shapes look amazing (hey, we are still engineers).

A lot of mode shapes show up, along with their resonant frequency and damping value. Visualizing the mode shape is easy – simply click the mode shape from the list and the animation automatically starts.

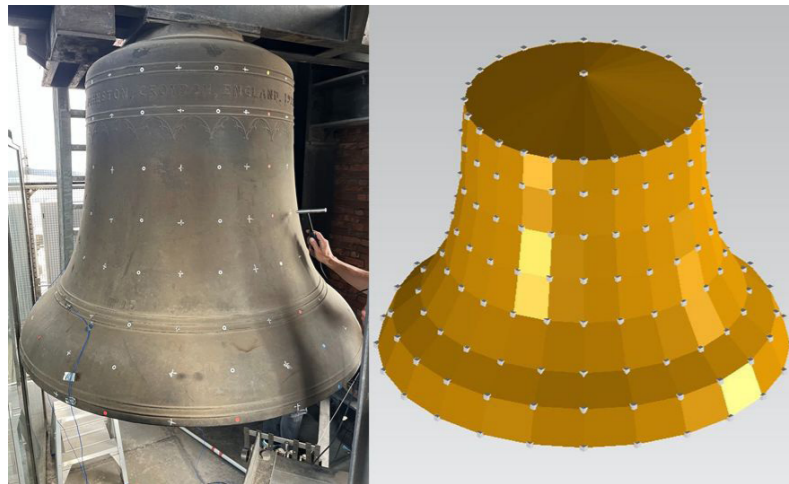

Interactive selection and visualization of mode shapes

Some more results below, linking the individual mode shapes to the corresponding frequency in the binaural audio recording. Notice that not all of the vibration patterns create a peak in the acoustic spectrum. This means the bell vibrates but is not generating any sound at this frequency.

All mode shapes

The mode shapes can also be described with a combination of Roman and Arabic numbers. I-3 corresponds to a mode shape with 1 maximum in the vertical direction and 3 maxima in the circular direction. In our bell example, this mode shape appears at 309Hz.

The frequency can also be described with its music annotation, where 128Hz corresponds to a "c", the harmonics at 256Hz is "c1", the double octave at 512Hz is "c2" etc. This gives the following table for the bell we measured.

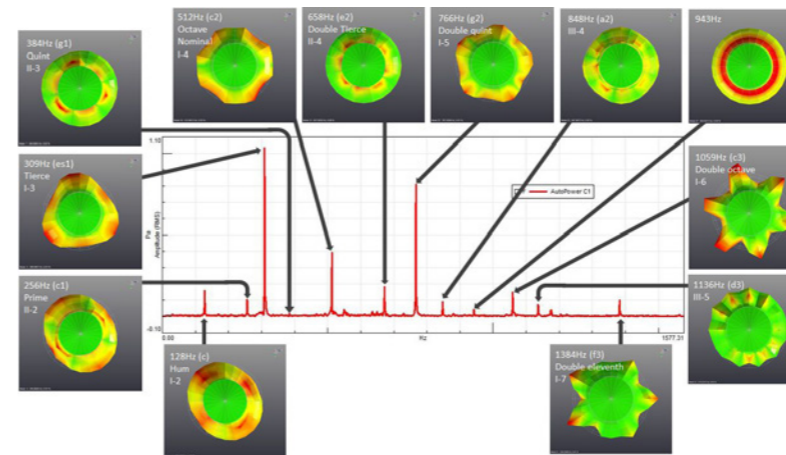
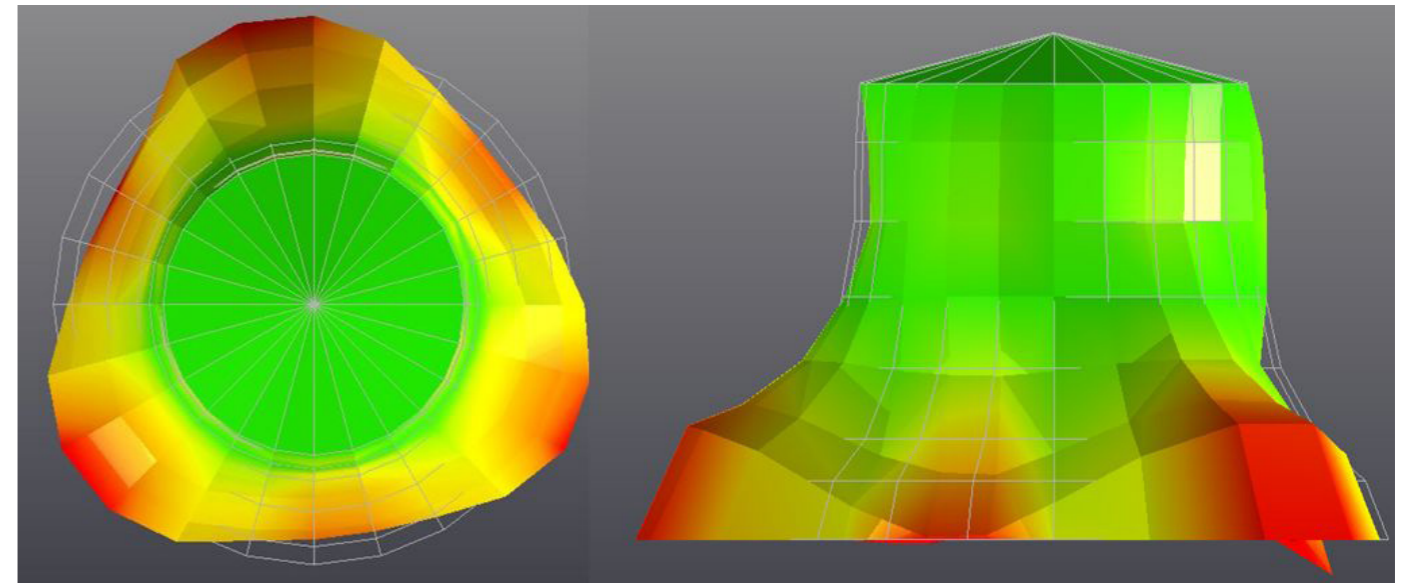

Overview deformation patterns

Name	Partial tone	Vibration pattern	Frequency (hz)
Hum	c	I-2	128
Prime	c1	II-2	256
Tierce/twelfth	es1	I-3	309
Quint	g1	II-3	384
Octave/nominal	c2	I-4	513
	e2	II-4	658
Double quint	g2	I-5	766
	a2	III-4	848
Double octave	c3	I-6	1,059
	d3	III-5	1,136
	-	-	1,175
Double undecime	f3	I-7	1,384

Different annotations for the deformations and tones

Campanology

There is much more magic in the tones of bells. The way we interpret the tones with our human brain can be different than those measured. The so called "strike tone" is a combination (in our brain) of 3 main vibration patterns and corresponding tones: the octave, the twelfth (double quint) and the double octave.

All this would lead us too far in this blog, but in case you want to learn more about it, just know that there is a [Royal carillon school](#) in Mechelen in Belgium. This school exists since 1922 and is the first, oldest and largest of its kind worldwide. Students from all over the world can attend "campanology" courses. [Luc Rombouts](#) teaches there and combines this with his job as official city carillonneur of Tienen, university carillonneur of Leuven and carillonneur of Park Abbey.

I would like to end with a big thank you to Luc for giving us access to the towers and carillon and for sharing his musical experience with us. It was a real pleasure to see how music and our Siemens engineering background nicely come together. Another great example of the usage of the Simcenter SCADAS XS for combined noise and vibration measurements.

Want to see other examples of how handy this pocket-size measurement instrument is? Checkout some other blogposts on [e-bikes](#) and [snowboard](#).

Interested in other applications related to music? Read the following article on an [Italian violin builder](#) or see how we did sound source localization on a [classical orchestra](#).



BROWNIAN MOTION

The random musings of a Fluid Dynamicist

Running and engineering, is it all about experience?

Your writer this time is not an engineer, and arguably not much of a runner either, but I am better at the latter than the former. But both running and engineers are a big part of my daily life, and whilst plodding last weekend I was reflecting on the similarities. The runners reading this will understand that zone where the mind takes off on its own to mask the pain of trainers on trail.

After a couple of miles (I didn't say I was a long-distance runner) mulling this over I concluded that whilst running and engineering may seem like two vastly different activities, there are in fact several similarities between them.

Discipline

First and foremost, both running and engineering require discipline and dedication. Just as a runner must consistently train and push themselves to improve their performance, an engineer must continually develop their skills and knowledge to stay at the forefront of their field. We run on data, cadence, splits, distance, time... there is a measure for all of these. Optimizing these gives the best possible outcome, sound familiar?



Goals

Another similarity is the importance of setting and achieving goals. Whether a runner is striving to set a personal best (a PB we like to call it) or an engineer is working to solve a complex problem, both require a clear understanding of what they want to achieve and a plan for how to get there.

Resilience

Both running and engineering can be both physically and mentally demanding. Whether pushing through the final miles of a marathon or working long hours to complete a project, both activities require a combination of mental toughness and physical endurance.

Kit

I know both runners and engineers love kit and gadgets, keen to see if the latest watch or trainers will give those extra few seconds, or that finer insight into performance. Sometimes they do and sometimes they don't. Engineers too have a vast choice of software and hardware to provide insight, speed or answers that were not otherwise available but just like with running you only achieve your goals if you know where you are going and put the effort in to getting there.

So, I will leave you with one final thought from Randy Pausch, experience is what you get when you didn't get what you wanted. And for both runners and engineers experience is everything.



So, I will leave you with one final thought from Randy Pausch, experience is what you get when you didn't get what you wanted. And for both runners and engineers experience is everything."