

Director of publication: Peter De Clerck

Editor-in-chief: Natasha Antunes

Although we make every effort to ensure the accuracy of Engineer Innovation, we cannot be held liable for incorrect information.

84789 22/09

Nemo's Garden

Once upon a time, there was a mesmerizing digital twin and a magical underwater garden...

Page 4

Letting electricity do the heavy lifting

Reducing heavy equipment power consumption and improving performance with simulation

Page 42

Step by step

Helping stroke patients regain mobility

Page 56

ISSUE 10

Engineer Innovation

A Simcenter publication

A sustainable world

Environmental impact of human activity, and how to make it more sustainable, remain at the heart of engineering innovation in 2022. No longer can we seek to simply mitigate the current environmental impacts; we need to eliminate them early in the design process! Simcenter recently launched an Engineer Innovation issue dedicated to sustainability, in this issue, we see our customers challenging and improving our environment comprehensively not focused only on carbon emissions. Real change requires tremendous effort and imagination, and this edition is further evidence that our customers really are tremendous.

What could be more imaginative than to grow our food underwater, Nemo's Garden is our lead article. It is also easy to be swept along in thinking that environment is our carbon footprint or the amount of plastic waste we as individuals produce, but as I consider the customer success stories in this issue, I am again reminded that they are being far more imaginative than that.

Our customers continue to make our everyday lives better, our partner NVIDIA develops faster GPUs and Cloud Computing enabling us to work anywhere, helping not only to reduce commute times but increase team connectivity across the globe. From making the work environment more flexible to improving medical outcomes for ventilated patients with Vyaire medical, by developing form-fitting masks to better built environments with ArcAero reducing the risk of death from dangerous downdrafts on skyscrapers or returning mobility to stroke sufferers with HEIR-AF University. And these solutions are not all Earth-bound they even extend to the International Space Station, we continue to see engineers seeking better and better outcomes for humankind, and not limiting themselves to just reducing carbon emissions.

À bientôt,
Jean-Claude



Contents

Explore the possibilities

Nemo's Garden	4
The evolution of vehicle performance engineering in the electrical age	26
Windy buildings and melting cars	34
Sustainability on the high seas	52

Model the complexity

Building a premium ride as standard	18
Step by step stroke recovery	56

Go faster

Beyond the power of the CPU	10
Taking the ritual out of bioreactor design	14
The future of road transport	22

Stay integrated

Letting electricity do the heavy lifting	42
Straddling the Kármán line	48
Subsea compression, the keystone of the energy transition	60

Regular features

Interview: Dr Christopher Varga	30
The executable digital twin	68
Geek Hub: Optimization and robust pizza camera design	72
Brownian motion	76

Image provided by
Nemo's Garden

EXPLORE THE POSSIBILITIES

Nemo's Garden

Once upon a time, there was a mesmerizing
digital twin and a magical underwater garden...
By Jenn Schlegel



Image provided by Nemo's Garden

It is not every day that inspiration strikes. So when you happen upon a story like Nemo's Garden and the save-the-planet potential of a simple underwater farm, you can't help but dive right in. Because like many a classic fairy tale, this story shows the magical power of dreaming big.

Today, just off the coast of Noli, Italy (between Genoa, Italy and Nice, France), you will find Nemo's Garden. Visible from the surface, it lies about 40 meters from the local beach at a depth of 6 to 10 meters.

But the real story started in the summer of 2012, when Sergio Gamberini, founder and president of the Italian diving equipment manufacturer, Ocean Reef Group, was vacationing on the Italian Riviera. Between dives, beach strolls and chats with friends about his other passion – gardening, he was struck by the most unusual idea: why not try to grow basil underwater? A couple of phone calls later and some help from his team at Ocean Reef Group, and he was experimenting with creating air-filled transparent biospheres 6 meters below the sea. That summer they successfully grew underwater basil.

10 years later

Today, Nemo's Garden's is a viable underwater greenhouse complex and pressurized underwater research lab. Consisting of 6 acrylic balloon



Built using Siemens NX software, the comprehensive digital twin of Nemo's Garden also includes the inner workings of the biosphere and its environment thanks to integrated Siemens Simcenter software. This advanced simulation can test out detailed case scenarios of any future situation.

structures that hold approximately 2,000 liters of air and float at different depths, these prototype biospheres harness all kinds of positive environmental factors from the ocean: temperature stability; evaporative water generation; CO₂ absorption; an abundance of oxygen; and the ultimate answer to every gardener's *bête noire* -- natural protection from bugs and pests.

Joined on this magical quest by his son, Luca Gamberini, Sergio Gamberini began to grow Nemo's Garden with a team of like-minded engineers, divers and scientists working to prove the viability of cultivating herbs, fruit and vegetables underwater. The first underwater basil was followed by lettuce in 2014. (The team feasted that summer on biosphere-grown salad topped with pesto made from their own biosphere basil. Already the dream was coming true.) Since then, the team has grown 50 different crops, including a variety of herbs, tomatoes and even strawberries. The team also discovered that plants grown in the biospheres are nutritionally richer than those grown traditionally.

Underwater basil for all

Recent stormy winters and the pandemic did set the project back a bit, but the team persevered. Nemo's Garden definitely worked, and they wanted to take it a step further than beachside

Noli, Italy. Could you replicate this idea easily so that others could create and install their own underwater gardens around the planet? Could you increase the growing cycle and therefore grow more food for the global population? Could you make the process smarter and less labor-intensive?

Taking the next step with TekSea and Siemens

Looking for answers to these questions about speeding up innovation and integrating cutting-edge technology, the team reached out to TekSea's Matteo Cavalleroni for insight. After initial discussions, Siemens was invited to join the project, leveraging the Siemens Xcelerator software portfolio and services to help Nemo's Garden get to the next stage of development.

"When I first saw the Siemens digital twin technology, I was mesmerized. Nemo's Garden is a one-of-a-kind system and we need to adapt to each environment where it is to be installed. If you can model that environment virtually before you start, you can foresee the challenges and address them in the best way," said Luca Gamberini, co-founder, Nemo's Garden. "We have seen benefits in understanding the flow of water around the shapes of our biospheres. We have a greater understanding of the points of stress on the structure around the biospheres. We also understand how the different interactions of the solar radiation, the temperature and all the physical factors act on the plants. All thanks to the ability of the digital twin to replicate our system."

The mesmerizing digital twin

The virtual aspect of Nemo's Garden starts with a comprehensive digital twin built using Siemens NX™ software. Covering the complete design, it also includes the inner workings of the biosphere and its environment thanks to integrated Siemens Simcenter™ software. An advanced simulation, the Siemens digital twin can test out detailed case scenarios of practically any future situation and location, including the biosphere's growing conditions and the environmental impact on the biosphere itself as well as the surrounding water.

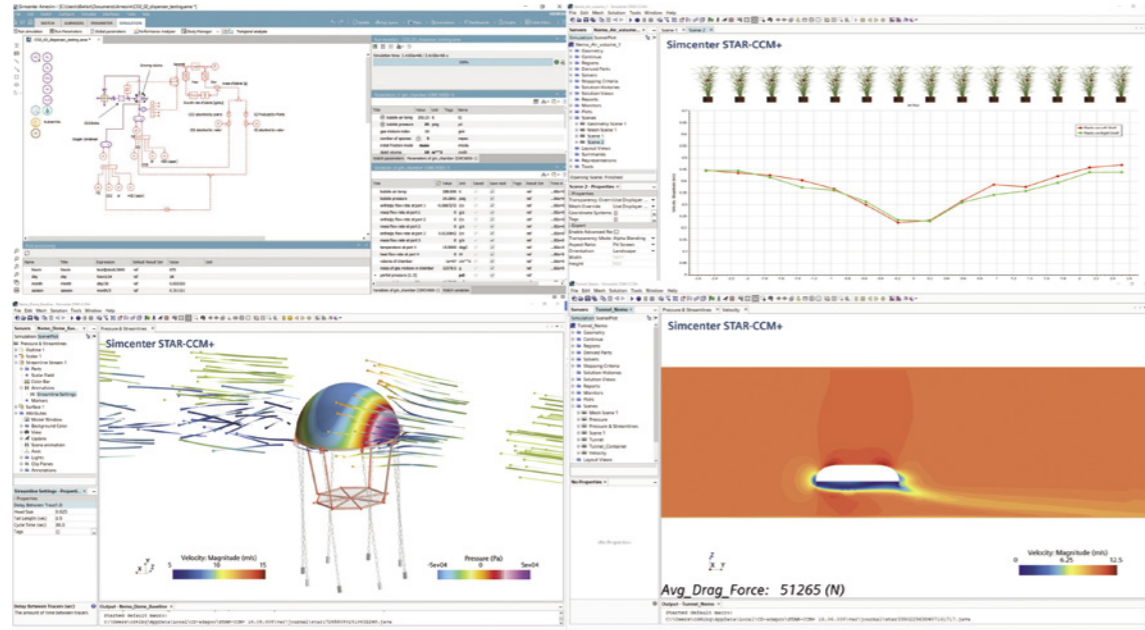

Using the Siemens digital twin, the team is no longer dependent on seasonal trial-and-error, stormy winters or availability of divers and monitoring staff. Adaptations to the biospheres can be tested in the virtual world, enabling the team to refine the entire design and operating conditions at a massively accelerated rate.

Fresh from the farm

Designing and operating the biospheres are just a part of Nemo's Garden. One also needs to keep track of what and how plants are growing, track their progress and conditions and tally up the harvests. For the most part, this job has been quite hands-on, meaning that qualified divers regularly check in on the biospheres and plants; this is complemented by manned onshore monitoring.

Obviously, today's technology can help create a more sustainable and practical business model that does not rely on trained divers collecting data and someone sitting behind a monitoring station watching the plants grow, literally. Siemens could lend a hand here as well thanks to its extensive experience in leveraging software and advanced AI technology to automate traditional farming practices.

Existing growth-cycle video and archived reference data from traditional farming practices at various growth stages and health conditions was analyzed

using the Siemens MindSphere® service. From this, Siemens was able to train a machine-learning algorithm to monitor plant growth as well as the environmental conditions within the biospheres.

Enter the AI farmer

To start, the team will run this algorithm on Siemens Industrial Edge computing devices in each biosphere. With sophisticated data analytics capabilities like these, the team will be able to monitor the plants via a cloud-based dashboard throughout the season from anywhere and in real-time. Next season, the plan is to connect the Siemens Industrial Edge devices to actuators to automatically adjust air circulation, humidity, irrigation and nutrition throughout the whole season. Together with Siemens, Nemo's Garden hopes this will be the foundation for a sustainable, global agricultural service, optimized for subsea operations and locations around the world. And just think, this all started with a dream to grow basil underwater.

The sea space around Nemo's Garden is open to the public. You are welcome to scuba dive or snorkel out to take a peek if you happen to be in the area. There are also guided diving tours available locally.

[Learn more](#)

How it works:

Inside the biospheres, water condenses on the inner walls, dripping back down to keep the plants watered, while the warm, near-constant sea temperature between day and night creates ideal growing conditions. In many cases, hydroponics is preferred – allowing the team to grow tomatoes and other vegetables.

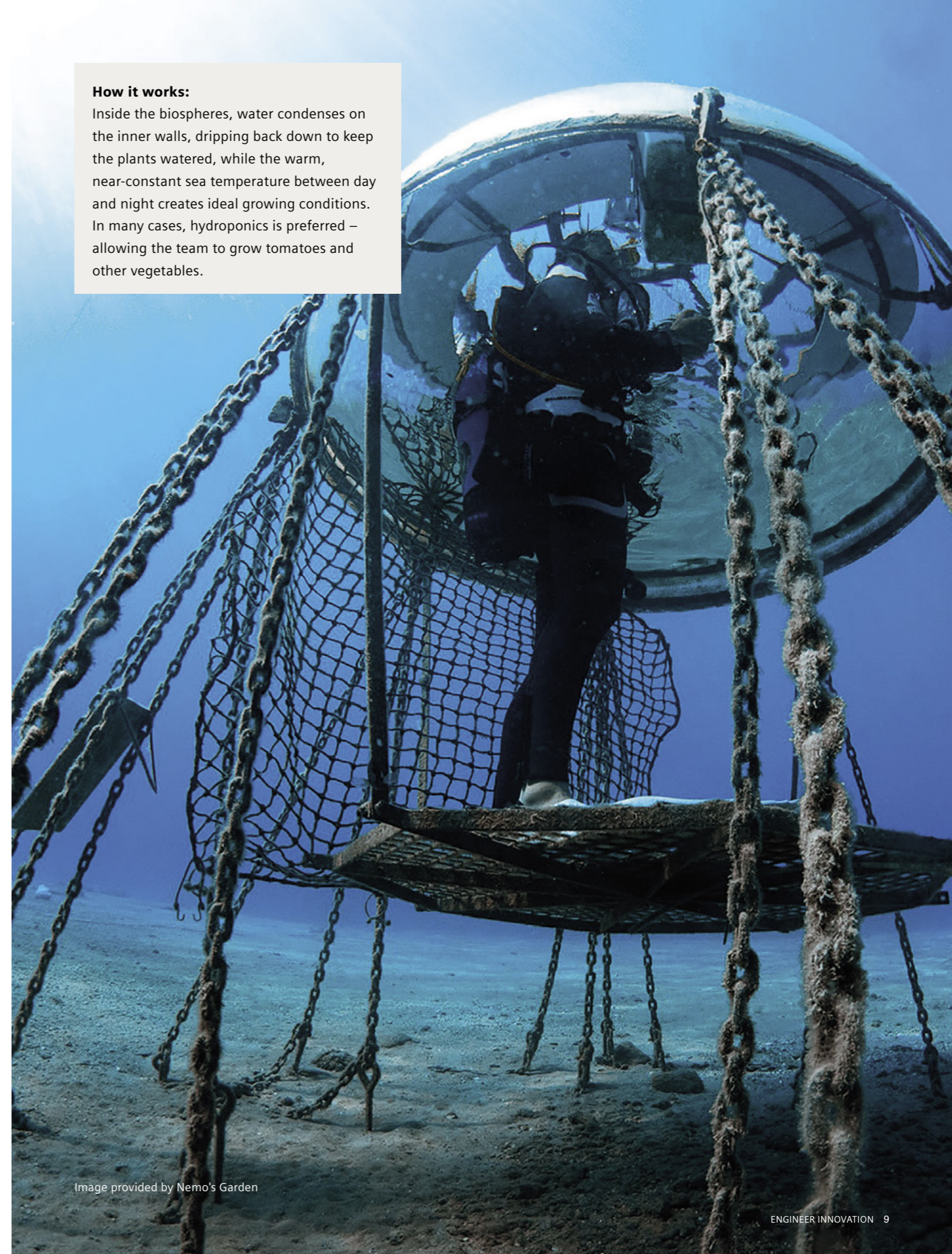
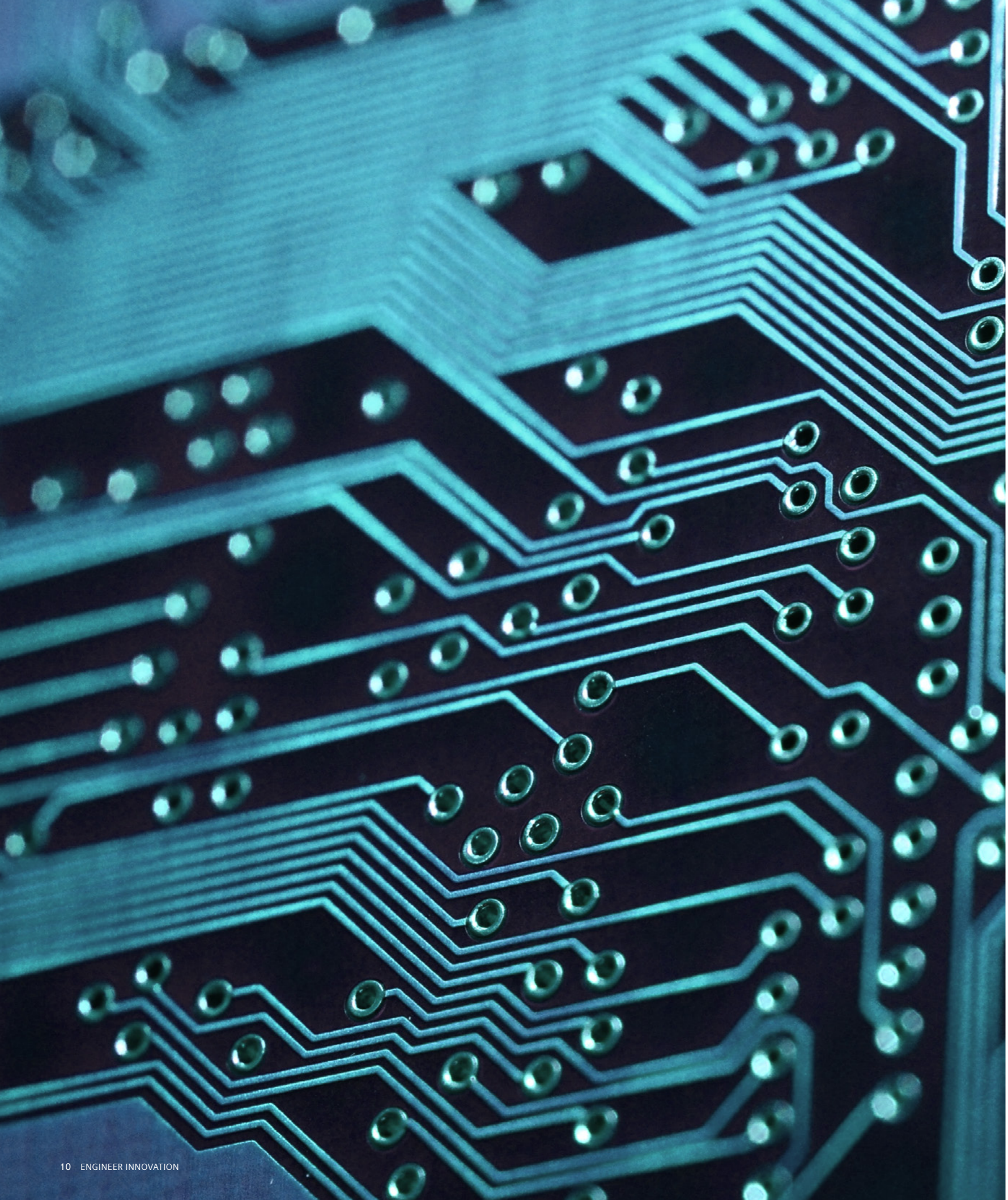

Image provided by Nemo's Garden



GO FASTER

Beyond the power of the CPU

Removing the limits on simulation
By Luke Morris

Since its inception, CFD simulation has been limited by processing power. The more complex models you build, the greater CPU you'll need to run simulations in a reasonable amount of time.

Thanks to CFD parallelization you can significantly speed up simulation time by investing in high end hardware, or a scalable cloud platform.

But this investment isn't cheap.

In fact, it can be a barrier to smaller companies growing within the CFD space as they can't compete with the sums that bigger, more established organisation can spend.

But what if simulation wasn't all about the CPU?

What if it could use other existing elements of computer hardware to take some of the load off the CPU without slowing down simulation?

Any gamer will tell you that the most important component of their computer is the GPU (graphics processing unit). Every computer has one. Without it, you wouldn't see any images on your monitor. But what if you could use the processing power of the GPU instead of the CPU for CFD simulation?

That's what Siemens and NVIDIA set out to discover in a collaboration designed to deliver faster simulation turnaround times at lower hardware investment costs.

Entering the age of the GPU

GPU architecture has developed rapidly in recent years, particularly thanks to NVIDIA introducing high bandwidth memory cards that allow for better collaboration between the CPU and GPU. At

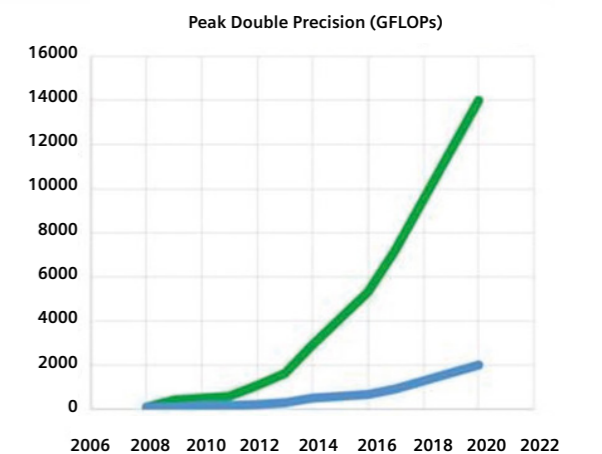
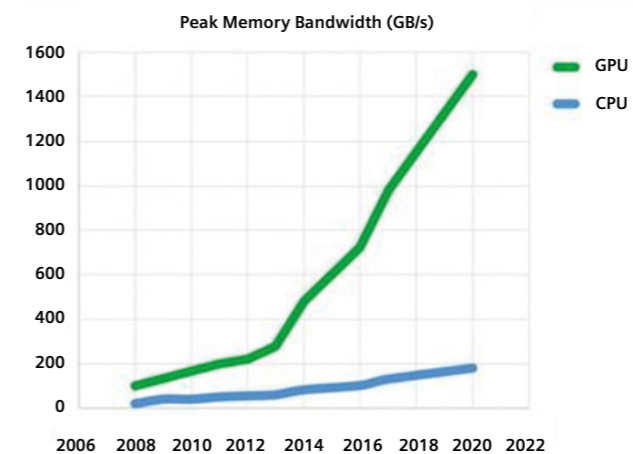



Siemens Simcenter STAR-CCM+ is giving an incredible boost to CFD simulations by using NVIDIA GPU technology via the CUDA platform and accelerated libraries. Simcenter STAR-CCM+ users can now run more simulations, faster, and can gain critical insights for their design and operation workflows without compromising on accuracy leveraging NVIDIA GPU architecture.”

Niveditha Krishnamoorthy
Developer Relations Manager
at NVIDIA

the same time, the evolution of CPUs appears to be slowing down in terms of peak memory bandwidth and peak double precision. And GPUs are known to deliver significant scalability and better performance at a lower price than CPUs.

Dr Vincent Natoli, Founder and CEO of Stone Ridge Tech notes that “When compared on a chip-to-chip basis against CPUs, GPUs have significantly better capability on both speed of calculation (FLOPS) and speed of data movement (bandwidth) (GB/s).”

The introduction of more flexible programming languages also allows larger parts of code to be ported to GPUs faster. So, with all this potential power available at a reduced cost it’s the perfect moment to utilise GPUs within CFD simulation to open it up to more users.

GPU-powered simulation

Working with NVIDIA, Siemens has developed Simcenter STAR-CCM+ 2022.1 to bring CUDA-enabled GPU acceleration to the simulation party. But what exactly has this achieved?

To prove the capabilities of the latest release of the software, Siemens and NVIDIA engineers ran a

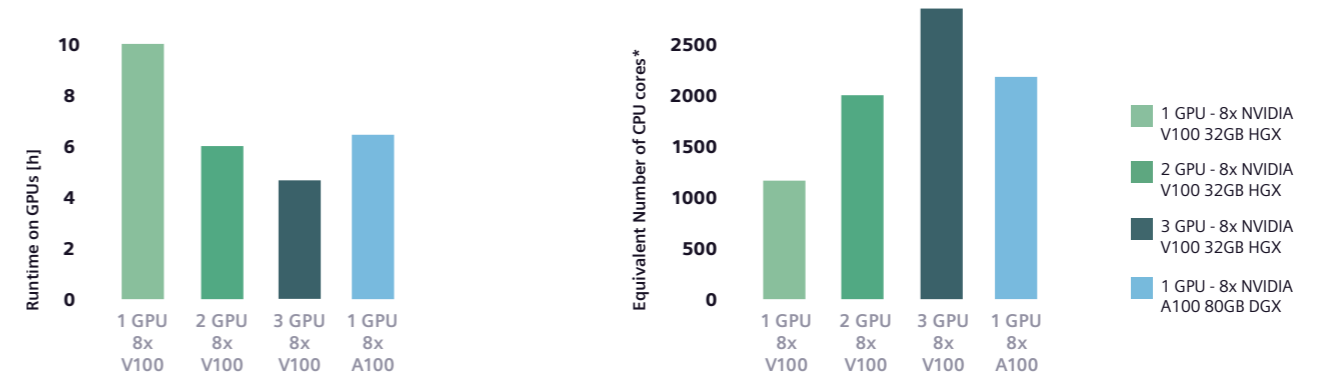

*CPU count to match respective GPU runtime. Compute optimized CPU instance: dual-socket Xeon Gold (40 cores per node)

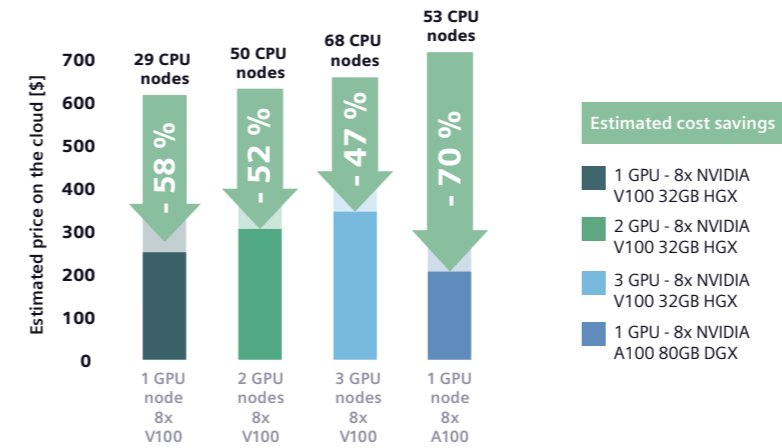

*Cost saving may vary. CPU count chosen to match GPU runtime. Prices for GPU and CPU compute resource estimated from popular cloud vendors: 8x NVIDIA V100 32GB HGX \$25/hr; 8x NVIDIA A100 80GB DGX \$33/hr; Compute-optimized CPU instance dual-socket Xeon Gold nodes (40 cores per node) \$2.10/hr

“Siemens Simcenter STAR-CCM+ is giving an incredible boost to CFD simulations by using NVIDIA GPU technology via the CUDA platform and accelerated libraries. Simcenter STAR-CCM+ users can now run more simulations, faster, and can gain critical insights for their design and operation workflows without compromising on accuracy leveraging NVIDIA GPU architecture.”

Niveditha Krishnamoorthy, Developer Relations Manager at NVIDIA

Beyond aerodynamics

So, this is great news for aerodynamics CFD engineers, but what about the rest of the simulation community?

Fear not, this is just the first step for the Simcenter STAR-CCM+ development team.

Now that the concept of NVIDIA GPU-enabled acceleration has been proved for aerodynamics, it can be taken much further. The plan is to extend it across all relevant core solvers, meaning that simulation engineers across all industries and applications will be able to take advantage of faster calculations at significantly reduced costs.

Whether you run your simulations on local hardware or in the cloud, GPU power will soon be available. There’ll be no more waiting days for tests to complete or slimming down simulations to get them finished in a short amount of time. Just imagine what engineers will be able to achieve when they have almost unlimited processing power.

set of industrial-grade external vehicle aerodynamics simulations on both CPUs and GPUs and compared the results.

Benchmarking proved that by using GPUs the hardware cost could be reduced to 40% and the power consumption to 10% of the CPU equivalent. And that would maintain an identical time to solution.

The tests also found that scaling across GPU nodes gives further benefits. In fact, one single NVIDIA 8xA100 80GB DGX achieves an equivalent runtime to 2120 CPU cores. So, if you want to, you can run simulations much quicker on GPUs instead of CPUs and still save on cost and power.

Save more in the Cloud

If you run your simulations on a cloud platform there are even more savings to be made. Based on average pricing from the most popular cloud vendors, switching to GPU computational power can save as much as 70%, as the graphic below shows.

GO FASTER

ABEC: Taking the ritual out of bioreactor design

From lab-scale to industrial-scale
By Stephen Ferguson



Image provided by ABEC

Science or magic? The origins of biochemistry

Humans have been using microorganisms to transform raw materials into useful products since before the dawn of history through fermentation. Before [the discovery of microorganisms \(such as yeast and bacteria\) about 350 years ago](#), this process must have seemed like magic. Indeed, fermented foods, drinks and sometimes medicines are part of every culture and are often bound up in ancient rituals that somehow provide the perfect conditions for a complex biochemical process.

[Wine, bread, yoghurt, sauerkraut, and kimchi](#) are all the result of biological reactions in which single-cell organisms (such as yeast or bacteria) transform boring (and often unappetizing) ingredients into a delicious (and sometimes intoxicating) end product.

However, in our hygiene-obsessed refrigerator-equipped modern world, most of us have come to regard bacteria as a threat to our health rather than as a potentially beneficial processing agent. We tend to delegate fermentation (and other biochemical processing) to experts in labs and industrial processing facilities.

Industrial biochemistry

Since the 1970s, our species has become highly competent at using biological agents such as cell cultures, microorganisms or enzymes for biological processing on an industrial scale. Indeed, in many ways, humanity has become entirely dependent on these processes for our continued survival.

At the heart of these industrial processes are bioreactors: vessels in which carefully controlled biological reactions are performed. Many are used to grow cells or other micro-organisms for these processes.

In addition to their role in food production, bioreactors are used today to produce pharmaceuticals, antibodies and vaccines, including [playing a critical role in responding to the Covid-19 pandemic](#). Increasingly bioreactors

are also being used to grow mammalian tissue from stem cells, either for transplant purposes or as [a source of low-carbon guilt-free meat](#).

And those ancient brewing processes that intoxicated nearly all of our ancestors? They are being redeployed on an industrial scale to create low-carbon bio-fuels from corn.

The simplest bioreactors involve lab-scale experiments using Petri-dishes and shaken flasks, which are used to demonstrate the viability and efficacy of a biochemical process. At industrial scale, bioreactors are typically large cylindrical tanks that are agitated using an impeller.

Every medicine ever developed - every vaccine - and every biochemical process started in a lab, developed and tested in small batches until it was ready to be produced in large quantities, often in multiple production facilities across the globe.

Therein lies the challenge – biological processes do not scale linearly with the geometric size of the bioreactor. Maintaining the ideal cultivation conditions developed in a 10-litre bench experiment in a 4000-litre industrial bioreactor is a difficult engineering problem.



Image provided by ABEC



Image provided by ABEC

Scaling up: the ABEC way

In the pharmaceutical world, the undisputed experts in the bioreactor scaling process is [ABEC](#), a company which has provided engineering, equipment and services to the biopharmaceutical industry throughout the world since 1974. ABEC provides custom-engineered solutions for the life sciences industry, supporting their efforts to create life-changing therapies. The company offers a range of engineering solutions for manufacturing therapeutics. Since its inception, ABEC has enhanced its capabilities as technological advances became available.

At the beginning, customer systems were being operated manually, but today ABEC assists the biopharmaceutical customer in bridging different platforms, from small to large, to ensure the same results are achieved everywhere.

We spoke to [Paul Kubera](#), vice president of process technology at ABEC, to find out about the critical role that simulation plays in that process.

“A typical scenario might involve a project that has moved from the laboratory bench at the tens-of-liters scale to process development, which may be operating on a few hundreds-of-liters scales. And then into production where they need to ramp up by thousands of liters in multiple units,” said Kubera.

The challenge with bioreactors is keeping the host-cell-platform alive. According to Kubera, “The growth of the organism must be supported – it needs food, a carbon source and to take in oxygen and give off carbon dioxide. It is critical to be able to deliver a known amount of oxygen in a given timeframe and remove carbon dioxide for all the organisms in the vessel.”

So the problem is essentially one of mixing: providing ensuring that all the organisms are exposed to relatively homogeneous environment for the weeks, or even months, that it takes for biochemical processes to be effective.

It’s a classical fluid dynamics problem but with one caveat: the working fluid is literally alive. Therein lies the challenge: as the scale of the vessel increases, so do the turbulent shear stresses used to perform mixing. If not carefully controlled, these can harm or even kill the cells.

In the traditional vaccine development process, which took many years, this scale up process was often lengthy and expensive, and based mostly around trial and error. However, ABEC has found the most effective process includes desktop calculations, small-scale tests to generate data and validate CFD, full-scale CFD modeling and full-scale confirmation testing. ABEC relies on Siemens Simcenter STAR-CCM+ software for performing CFD simulations.

“With Simcenter, we can run a computational simulation of the laboratory configuration and confirm the same results. We can then run a large-scale simulation and be confident that the measured performance of the delivered equipment will track with expectations,” said Kubera. “As an example, we demonstrated that we can cut blend time 50 percent by using laboratory tests to screen options and Simcenter simulation to extend the results.”

“Siemens provides us with the support we need to demonstrate to our customers this equipment can operate in a very predictable fashion immediately upon startup, reducing their time-to-market. Our relationship with Siemens Digital Industries Software helps us very capably provide that service.”

As valuable a tool as Simcenter STAR-CCM+ is for ABEC, they are aware that it is capable of even more: “We don’t perform enough CFD to take full advantage of all that it can do for us,” says Kubera. “Siemens provides us with the support we need to demonstrate to our customers this equipment can operate in a very predictable fashion immediately upon startup, reducing their time-to-market. Our relationship with Siemens Digital Industries Software helps us very capably provide that service.”

ABEC continues to innovate, recently introducing the 6,000-liter Custom Single Run™ bioreactor, effectively tripling the industry-standard capacity for single-use bioreactors.

While modern industrial bioreactors might not rely on as much actual magic as the ancient fermentation processes pioneered by our ancestors, it should be clear that Simcenter has helped remove much of the ritual from the process and replace it with science.

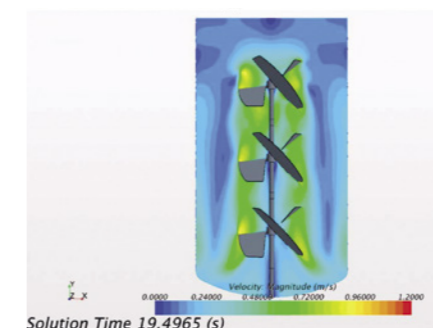
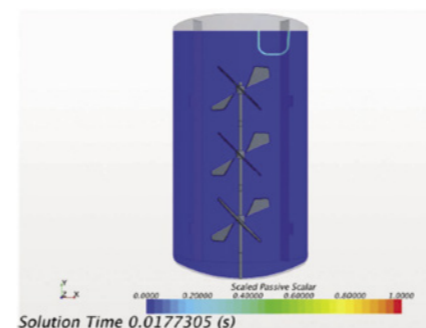
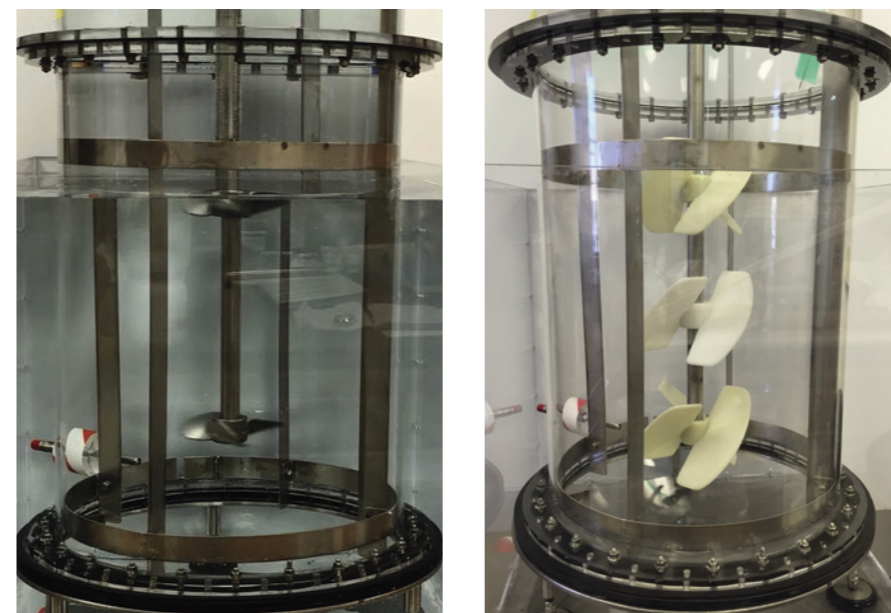

Images provided by ABEC

MODEL THE COMPLEXITY

Building a premium ride as standard

A reputation built on quality and delivered with simulation
By Luke Morris



Image provided by
Daimler Truck

Mercedes-Benz was founded nearly 100 years ago and throughout that time the name has always been synonymous with quality and style. No surprise then that it was recognised as the [world's most valuable premium automotive brand in a 2019 study by Interbrand](#).

But attaining and maintaining such an accolade doesn't come easily. Especially since the company has broadened their product range over the years by acquiring brands such as Daimler Truck. Any vehicle associated with Mercedes must live up to the premium, luxury expectations. It's not enough to look good and perform well – features such as reliability, ride, comfort, and integrated technology are all essential.

There's also the not-so-small matter of needing to continue developing conventional thermal engine powered vehicles alongside fuel cell and electric powertrains. And did I mention autonomous vehicles and all the extra electronics and sensors needed to enable platooning or self-driving?

All these factors are critical to the continued success of the brand, but comfort is arguably most important in distinguishing Mercedes products apart as luxurious. Customers expect to feel the premium quality as soon as they get behind the wheel, and the best way to deliver this is by reducing the noise, vibration, and harshness (NVH) experienced.

Revolution with simulation

Mercedes has been using Simcenter Nastran software for NVH engineering since 2004 to meet its lofty targets in this area.

Simcenter Nastran is a premier finite element analysis (FEA) solver for dynamics, NVH, and structural analysis. Essentially, it allows engineers

to optimize NVH performance without the need for building countless prototypes that cost significant time and money.

In the past, optimization was limited as each change required a new prototype to verify improved performance. There's only so many resources that can be allocated to designing each model so compromises had to be made in order to get products to market within a reasonable timeframe.

Simulation has revolutionised this. Engineers can now simulate individual components or complete vehicles to understand exactly how they will vibrate when in operation and how this will impact on driver and passenger comfort. These digital models can be built and tested in a matter of days – much faster and cheaper than physical testing – meaning that more design iterations can be processed, and more ideas explored to reach the optimum designs.

This couldn't be achieved with just any simulation tool. Engineers need to be confident that the prediction quality of simulation is at least as accurate, if not more so, than physical testing. Mercedes uses Simcenter Nastran because it can efficiently handle large models with up to 30 to 50 million degrees-of-freedom (DOF). It also simulates engine, road, and wind noise, and covers a large number of load cases over a broad frequency range.

Easy collaboration

Another reason Mercedes has continued using Simcenter Nastran for so long is the ease of integrating third-party software tools in pre- and postprocessing.

Glue connections allow engineers to more easily model the interface between the structural model and fluid model. And model reduction techniques such as the Craig-Bampton methods enable the easy exchange of data on supplied components and vehicle behaviour without exposing valuable intellectual property – vital to making progress without giving away design secrets.



Image provided by Daimler Truck

Most importantly, Simcenter Nastran has been consistently matching the results from physical testing, giving engineers confidence to trust simulation and increase its use throughout the development process.

Extending simulation further

Following on from the proven success of simulation, Daimler Truck has recently adopted Simcenter STAR-CCM+ to develop the next generation of CO₂-neutral vehicles.

By transforming its CAE development process to a full digital twin-driven Multiphysics environment, Daimler will be able to simulate all the fluid and thermal aspects of design.

Did you know over 52% of fuel use is down to the engine power needed to overcome wind resistance? Simulation enables the improvement of aerodynamic performance and thus reduces emissions even before moving away from thermal engines. And when it comes to optimizing electric powertrains, Simcenter STAR-CCM+ allows engineers to look at multi-attribute trade-offs to minimize energy usage while maintaining performance and ensuring efficient cooling of batteries and electronics.

Oh, and they will also be able to improve that all-important comfort factor further. Multi-phase simulation helps to reduce soiling on side windows, mirrors, and sensors, improving user visibility and autonomous system performance in any weather.

Never-ending support

Incorporating new technologies into established development processes isn't easy. This is why Siemens support customers such as Mercedes every step of the way. A dedicated engineer has been assigned to Daimler to facilitate the integration of Simcenter STAR CCM+ and train their staff to become expert simulation specialists.

One of the great benefits of the Simcenter portfolio is how it fosters closer collaboration between teams. It's just as important to have close communication and cooperation between customers and Simcenter development engineers. This is why Simcenter Engineering Services are always on hand to offer assistance with any simulation tools – not only does it help customers to make best use of the products, but it also drives innovation at Siemens and influences the development path for future releases.



ENGINEER INNOVATION

Sustainable World

Did you know that in the last 220 years, humans have caused over 1.6 trillion tonnes of CO₂ to be emitted into the environment? The transition to a green future is one of the biggest engineering challenges we have ever faced.

From how we can meet net-zero carbon targets by 2050, to the impact of global warming on extreme weather events, this special edition of Engineer Innovation explores the role that Simcenter is playing in solving the climate emergency by engineering a low-carbon future.

Available to read online now:

<https://media.plm.automation.siemens.com/simcenter/flipbook-new-9/ei9/cover/>

SIEMENS



GO FASTER

The future of road transport

How simulation is powering innovation
By Luke Morris

Modern transportation has changed the world. By drastically cutting journey times countries, continents, and indeed the whole globe have become much smaller. People and goods can travel further and faster, opening up new economic possibilities for everyone.

But the adoption of the internal combustion engine as the preferred method of powering transport for the best part of a century has come at a significant cost. Of the 50 billion tonnes of CO₂ emitted globally each year, 8 billion comes from transport alone. Road passenger and freight vehicles account for around 75% of this figure.

Switching to electric propulsion is an obvious way to significantly reduce this impact. According to the latest Mobility Consumer Index, more than 50% planning to buy a car will choose either a fully electric, plug-in hybrid, or hybrid vehicle.

Something must change, and fast. If emission reduction targets are to be met and a climate catastrophe avoided, the automotive industry must accelerate the transition from internal combustion propulsion to electric propulsion. As Bill Gates recently said, "We need to be adopting electric vehicles as fast as we bought clothes

dryers and colour TVs when those became available."

This is far easier said than done, however. Manufacturers need to produce vehicles that customers want and offer them at a competitive price. For a company like General Motors (GM) which has over 100 years of experience with brands such as Chevrolet, Buick, GMC, and Cadillac, a new approach to development is needed to produce the environmentally friendly and economically viable vehicles of the future.

Of course, it's not possible to make an immediate and complete switch to producing electric vehicles. GM needs to follow a carefully planned transition, which means developing internal combustion engines, hybrid drive units, and electric drive units at the same time.

This means an increased number of complicated, separate development threads. Finding ways to reduce the cost of each thread and speed up development time is critical to a successful transition and the continued profitability of the company.

Michael J Grimmer is Technical Fellow in the Propulsion System Global Noise and Vibration department at GM. He explained how his team has adopted simulation to meet these challenges, facilitate innovation, and help the company stay ahead in an increasingly competitive market.

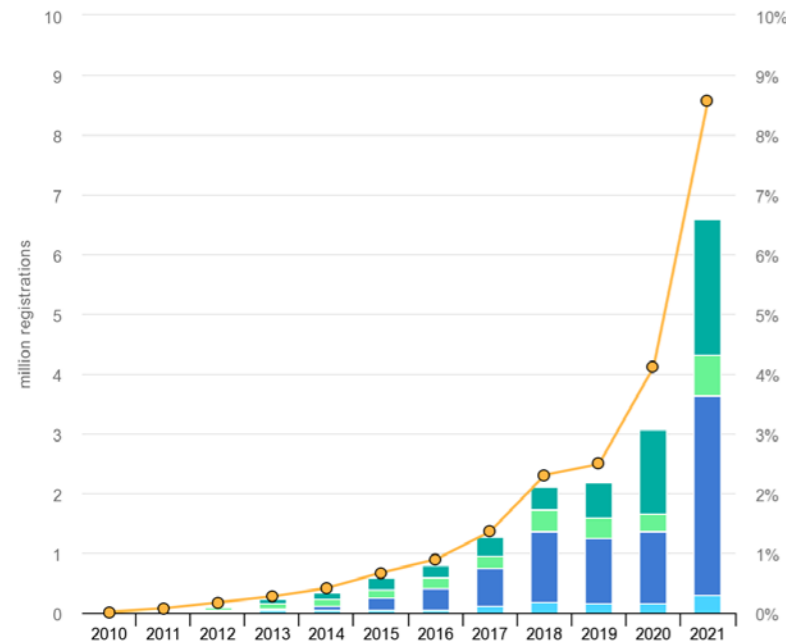

Driving quality forward

Whichever type of vehicle is being developed, driveline quality is key to performance, comfort, and fuel economy. To optimise it, engineers need to fully understand the energy efficiency on the drive quality and seat acceleration experienced by the driver and passengers.

Building physical prototypes to carry out these tests is an expensive and time-consuming process. To overcome this, GM has used Simcenter Amesim to build comprehensive digital twins of each vehicle they develop. This allows them to perform many more what-if analyses than previously, so that when they do build a physical prototype it is much closer to the ideal solution.

Grimmer cites driveline noise and vibration reduction as an example. Previously, they had to design and build prototypes of components such as isolators and perform physical tests to understand their impact. This would typically take several months and cost up to \$50,000. With Simcenter Amesim, GM engineers can create these isolators virtually using model-based systems engineering (MBSE) techniques and carry out the testing in the simulation environment. All in a matter of days at a significantly reduced cost.

Encouraging innovation

Simulation has also delivered a huge boost to innovation for GM. When physical prototypes are needed to prove concepts, risk must be minimized to avoid wasting critical development time and

money. Engineering experience, best practice, and analysing results from existing similar products can only do so much, and this limits the opportunity for innovation.

By introducing simulation, engineers can experiment with their designs and test many more concepts in a much-reduced timeframe. Grimmer says, "We can do concept selection based on simulation of how products will perform. This greatly expedites the number of options we can consider and the correctness of the ones that we choose."

Ultimately, accurate simulation is enabling innovations in vehicle design that would never previously have the chance to be fully explored and realised.

Improved methodology

With the adoption of Simcenter, GM has established new simulation-based standard work practices that improve their overall development processes. In the case of driveline noise and vibration, this means better optimisation and balance of all elements. They have used simulation to establish best practices that also take into account the energy and fuel economy requirements of each vehicle. The capability to simulate so many different designs and scenarios allows engineers to develop solutions that achieve the optimum balance across these different performance areas that previously wasn't possible.

The Simcenter portfolio also enables better cooperation between teams and suppliers as models can be easily shared, as Grimmer explains:

"The Simcenter Amesim models that we build are easy to operate by others and can be integrated into the rest of the system and with the controls. Another user from a different engineering team can receive the subsystem model from us or even from a supplier as a black box and integrate it in their workflows quite effectively."

Technology that evolves with the industry

As vehicle technology, and electric technology in particular, continues to evolve at a rapid pace, simulation must evolve too to keep up and



maintain its usefulness. To ensure the software is always at the cutting edge of simulation, Simcenter Engineering and Consulting services work closely with companies such as GM to understand the challenges they face and inform the future direction of products like Simcenter Amesim.

Grimmer says his GM engineers will work with the product development team on new or improved features that will enhance their experience and add functionality.

"Modelling torsional isolators within the transmission involve arc springs that have unique physics and Simcenter Amesim has an out-of-the-box sub model for modelling those physics, which was improved to achieve much quicker and accurate simulation," he says. "Another example is what's called a viscoelastic spring and its interface was improved for a more intuitive version based on our needs. That was extraordinary product support. We're very pleased with the product support we get with Simcenter Amesim."

Transition of practices as well as products

Physical testing is still a crucial component of the overall development process to ensure optimum quality in new vehicles. But clearly the more

testing that can be replaced with simulation, the better, cheaper, and faster development will be.

To advance this transition, GM exports simulation data from Simcenter Amesim into Simcenter Testlab to compare simulation results directly with test data. This enables validation of their virtual models and gives increased confidence in using more simulation in the future.

Grimmer firmly believes that simulation accelerates product performance prediction, allowing teams to make well-informed decisions in earlier development stages. As simulation improves it's becoming possible to not only model and simulate a broader range of product designs, but also production, manufacturing variation, and what-if analyses.

So, the key to reducing road transport's impact on the environment is not one transition but two. For GM and other manufacturers to carry out a successful transition to more environmentally friendly vehicles and stay competitive they need the support of a technology transition: the introduction and increase of the use of simulation to enhance their development processes, foster innovation, and reduce costs and time to market.



EXPLORE THE POSSIBILITIES

The evolution of vehicle performance engineering in the electrical age

By Els Verlinden

New technology needs new processes

The transition to autonomous and electric vehicles creates new challenges for the automotive industry. In the past, manufacturers have been used to developing two or three new models each year. Now, to keep up with growing demand and remain competitive in the age of electrification, companies such as Toyota aim to develop thirty new electric vehicle models by 2030.

An electric motor is much simpler than a combustion engine in most respects. There are far fewer moving parts, and you just need to combine a motor with a battery and an inverter, and you're ready to go.

But to improve the efficiency and performance of electric vehicles, manufacturers now put the inverter, motor, and gearbox all into one container. This means engineers from several different specialisms who previously worked very separately now have to come together to ensure their components complement each other perfectly. First, you have the electronics, electromagnetic, and mechanical engineers, and then you have software engineers working on the controls for all the components.

So how do you get all these people from different backgrounds and skill sets working together to optimize vehicle performance and keep up with the challenge of developing many more models than before?

SAE International recently hosted a webinar with this in mind. Three Siemens experts got together to explain how the vehicle development process is being transformed to make it fit for the future:



Katrien Wyckaert
Vice President Strategy and Innovation



Steven Dom
Director Automotive Industry Solutions



Fred Ross
Automotive Business Development Manager, Fluids and Thermal Domain

They answered questions from the audience such as:

- How is the role of simulation evolving in the trend of model-based systems engineering (MBSE)?



The Pandora EV concept vehicle. Image provided by SAE International

- How can businesses integrate with their existing toolset, and how will their development process transform over the coming years?
- How can CAD data be shared with simulation?
- What are the simplest and most complex subsystems to develop?
- Can Simcenter use real-world driver usage feedback to validate testing models and aid development?
- Will governing bodies such as NHTSA or FAA encourage or facilitate a move to MBSE tools?

Collaboration and integration

After the webinar, I caught up with Steven Dom to learn more about what was discussed and how Siemens is helping manufacturers meet the new challenges of autonomous and electric vehicle performance engineering.

He explained how simulation is enabling the evolution of vehicle design and allowing a more integrated view of vehicle development from the earliest stages:

"Typically, the development would diverge into different areas of engineering and only come together at certain milestones during a project. But that isn't the optimal way to work, and when you need to develop more models in a shorter timeframe, it's just too inefficient. You need to think in a more integrated way where everyone on a project can see what others are doing at the same time."

In the webinar, he gives specific examples of where isolated working leads to lots of redesign

and delays that collaboration can avoid at an earlier stage. And collaboration is one of the great strengths of the Simcenter toolset – bringing specialists together to work on a model that delivers optimum performance from each element of the vehicle. The webinar includes detailed slides showing how different specialists can see exactly what others are working on and, as Steven puts it, 'piggyback' on the results of each other.

Interested in more examples of this? Check out Lionel Broglia's [blog](#).

Modular design and frontloaded simulation

McKinsey has [reported extensively](#) on the challenges of improving profitability in electric vehicles, and Steven says this is due to development processes not yet having evolved enough.

"They need to build a native and modular electric vehicle platform," he says. "I call it the Lego blocks principle – if you can build from predefined blocks, it's much easier and quicker than developing from scratch each time. Combine this with frontloading your simulations so you can make as many decisions as early as possible in the design process, and not only will the finished product be better, but it will also be cheaper and take less time to develop."

He goes on to explain how model-based system engineering (MBSE) is essential for successful vehicle performance engineering. In the webinar, Fred Ross also gives a detailed example of how Siemens are using collaboration tools to develop a concept vehicle.

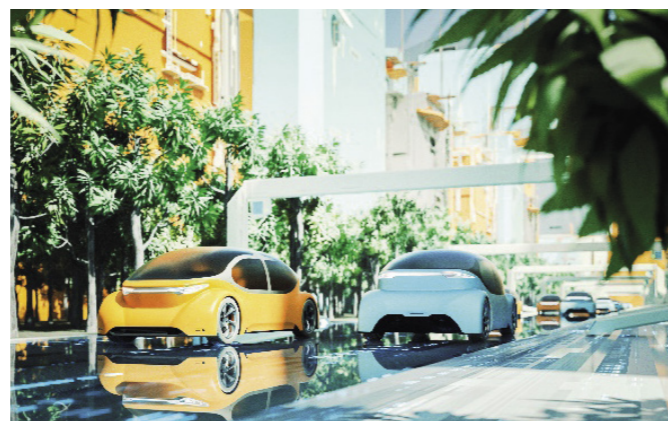

Image provided by SAE International

The latest Simcenter tools have improved physics and workflow, making the development of systems such as battery cooling even easier than before.

Bringing simulation and testing closer together

It's not all about simulation, though. Steven is keen to stress that a key element in improving vehicle performance engineering is the relationship between simulation and testing. "In the past, we'd use a simulation model to help define the layout of sensors on a test vehicle. Now we're bringing testing and simulation into the same environment and running them together." In the webinar, he explains how this gives much more accurate results than either on their own by allowing for the analysis of elements that previously wasn't possible.

The future is artificial (intelligence)

Artificial intelligence (AI) also has a crucial role in the development process. "Using virtual sensors, we can train a neural network using AI to learn how to extract the same data from a much simpler set of sensors than the complex, expensive ones previously used," Steven says. "This means you can achieve the results with less money and time spent on testing instrumentation."

And of course, another aspect of modern electric vehicles is autonomous driving. At some point in the future, the human element of driving will be removed completely, and Steven explains that AI is used in this area too. "The perception and control algorithms use extensive AI. It's a combination of creating your environment via testing and simulation and then using AI to validate different scenarios as fast as possible to come up with the best design."



Image provided by SAE International

From the first space rockets to 21st century vehicles

It is fascinating to see how the automotive industry is adapting to meet electrification challenges. Modern technology allows manufacturers to improve their processes to design and develop future vehicles.

The theory behind it is not as new as you might think, though. "You can trace model-based system engineering back to NASA and the early days of the space program," Steven says. "Hundreds, maybe thousands of people had to

collaborate to build safe and reliable rockets to get astronauts into space and to the moon and back. They used a form of MBSE then. So, the idea isn't new, but we have better tools now that have allowed us to bring it to the automotive industry in the last decade."

Watch the webinar now for the answers to all the questions posed and a detailed explanation of the role Simcenter is playing in the evolution of the automotive industry.

Q&A



Image provided by Christopher Varga

INTERVIEW

An interview with Christopher Varga, Ph.D., Senior Engineering Fellow at Vyair Medical

We first met [Dr Christopher Varga](#) at the 2018 Simcenter Conference in Prague. Christopher is a Senior Engineering Fellow and Senior Director of Research and Development at Vyair Medical.

In Prague Chris gave an impressive presentation that showed how Vyair is using simulation to design better ventilation equipment that supports breathing through every stage of life, and across all patient morphologies. In 2020 we realised just how critical that work was, as Vyair ventilation and respiration equipment was deployed across the world to help seriously ill patients win their fight against COVID-19. We caught up with Christopher again earlier this year to talk about the continued evolution of the healthcare industry and how it has impacted how products are brought to market.

Tell us a little bit about your career path and what you do currently

Sure. I had an interesting path to where I am today. I did my PhD in Mechanical and Aerospace Engineering at the University of California, San Diego, doing mostly experimental work on how to make tiny, tiny droplets for combustion applications, for things like rockets and missile propulsion. At the same time, I was falling in love with a lot of the medical projects that my advisor, the late [Juan Lasheras](#) was working on that were adjacent to my PhD work. I tried as much as I could to get involved in the medical stuff that he was doing with this thought in my head that maybe when I was done with my PhD, I could find an application for what I was doing in medicine. Luckily there was a small company called Inhale Therapeutics at the time, they were developing the world's first inhaled insulin and they needed somebody who knew how to make small droplets. You need to make tiny, tiny drug solution or suspension droplets if you're going to spray dry

them into powders that are going to get into the deep lung. So, I went to work there and that was my entrance into healthcare. I spent several years there with a small team of other scientists making equipment to make these specialized pharmaceutical powders. I've been in the healthcare industry ever since applying all of the engineering knowledge I have that was originally focused on aerospace applications, but applying it to healthcare applications.

I then moved to the company I'm at now, which has gone through many different names and ownership changes, but today we are called [Vyair Medical](#) and I've been at the company for almost 14 years now. We're a pure play respiratory company. So everything that you can think of that relates to taking care of people's breathing, most of the products you would encounter, we make something in the space.

I've spent the last 14 years working across all of our different franchises and businesses developing both big equipment, like lung function testing equipment, mechanical ventilators and things of that sort as well as all the [smaller consumable devices like oxygen masks](#), nebulizers, ventilation circuits, humidifiers and things like that which support patient breathing. Most recently I have been working on software products that help our clinician customers to simplify their workflows and take better care of their patients in the ICUs in particular. Today, I lead our innovation efforts in digital health at Vyair and while for the last few years these efforts have primarily been focused in the mechanical ventilation space, the business is

growing and becoming more broadly encompassing of all of our franchises.

In the time that you've been in the healthcare industry, what are the biggest changes you have seen?

Well, number one, regulatory scrutiny has grown. And because of this, products require more testing and it's taking longer to bring innovations to market. There are certainly ongoing efforts being made to streamline regulations to support rapid innovation but nevertheless the time from product inception to market launch has grown.

And then the other big change I've seen of course is the advancement in technology in terms of how we can design and build things. Being able to simulate products before you ever build a prototype just puts so much power into the hands of the engineer today. Power that we didn't have when you had to build something, test it and build it again and test it and you couldn't even build it fast. So rapid prototyping, simulation and those technical advances have just changed the way we make products in a fascinating and awesome way.

14 years ago, when you first started, did people take you seriously instantly or did you have to do some kind of evangelizing to make sure people understand that simulation was a relevant part of the product design and approval process?

There was definitely an effort that was required. 14 years ago, at least in certain spaces in healthcare, there was

not a lot of simulation happening. I think we had maybe one engineer that was dabbling a little in simulation at the time I joined the company. We were doing mostly build, test, go back to the drawing board, et cetera. When I first started to bring simulations into presentations, I remember there were a lot of folks, particularly in the non-engineering functions, that thought that this, the images or the simulations, were more like movies or just marketing propaganda.

I had to explain to them that, "No, we're solving the fundamental governing equations here and this is real stuff that you're seeing!" That took some time. But I think what happened is people started to recognize how powerful those tools were and how we could much more rapidly iterate through concepts. And when you can validate results against experimental tests, people were like, "We've got to train more people on this." Or "We've got to keep this subscription going." So yeah, it took a little time and then it just grew and grew and now it's part of everything we do really.

What are you working on right now?

So right now I am working on the development of [mobile apps for clinicians](#), in particular, doctors, nurses, and respiratory therapists that are in the hospital taking care of ventilated patients in the ICU. Mobile apps that support their workflows, protocols and clinical decisions. When a patient is put on a ventilator, the first thing you focus on is stabilizing them and then getting them off the ventilator because it's not a good place to be. It's not a natural way to breathe. So weaning is crucial, but weaning is also complex because it involves a kind of a dance between respiratory support and sedation medication. Sedation makes ventilation more comfortable for the patient but can also make it more challenging to get them breathing on their own again.

So, one set of tools we provide in our mobile applications helps with this dance and aids the clinician in coordinating spontaneous breathing and awakening trials. Broadly speaking we are providing clinical decision support tools that the clinician can access on their mobile device, along

with critical patient information. This helps them know who to see, when and why.

I assume that is data driven. You have to collect large amounts of data to be able to make those choices automatically.

So today we utilize fairly simplistic rules and thresholds. If this, then that type logic. More sophisticated algorithms are certainly coming in the future, but yeah, of course we have to look at all the data flowing from the ventilator as well as the data coming from the infusion pumps and the boluses of drugs that they're getting. And our system is continuously analyzing these data streams, and then providing those insights.

Do you think there is a shift in the industry towards personalized healthcare? We know Vyaire Medical led the way in creating masks to fit different head morphologies, do you see this as the future of healthcare?

So I think there's a few things. Personalized ventilation is one of our focus areas. By this I mean a shift from using, let's say broad guidelines to set conditions for a patient on the ventilator to enabling ventilation tailored to that patient, according to their lung condition, their lung morphology, and to really do more adaptive ventilation for their individual condition. And that can involve a few different things. One is of course having algorithms on the ventilator that can detect and adapt. So one of our flagship ventilators, our bellavista™ has an adaptive ventilation mode that recalculates each breath, to determine the ideal condition for the next breath.

And then outside of that, today we have the power and the tools for example to image the lung, segment it and run simulations. If you had the ability to do that, of course in real time, or closer to real time, then you could provide really personalized ventilation because now you're not just measuring external parameters of the patient's breathing, you're getting inside the patient and seeing what's happening. With simulation and modeling we have the potential to provide respiratory care that is much more personalized which is incredibly exciting.

Everyone is tired of talking about COVID and the pandemic, but I can remember talking to you during the midst of the pandemic and it was all hands to deck. Vyaire Medical did a fantastic job innovating in real time to deal with the production issues around deploying ventilators. Have you learned any lessons from all that and do you think you're more prepared for the next pandemic, whatever that might be?

I think that the short answer is yes, absolutely. We learned so much, I think in that timeframe about production, testing, supply chain, how to really dig into things when we had to. I think we're just now much more lean, we're much smarter about how we source, et cetera. Yeah. We're prepared for something like this to happen again.

How a manufacturing moonshot was made

Which I think is one of the benefits of kind of getting through the whole experience, isn't it? The whole world just about surviving and everybody's more aware of the risks and prepared to invest more in the solutions as well. One last question... Do you have any pearls of wisdom you want to impart?

Anything you want to put out into the world? [Laughs] I mean, maybe just that I think laughter is the fuel for a lot of different things. I think that we can never be too serious about ourselves or things we're doing, even if they're super important like building healthcare products. I just think laughing is a big part of my life and being silly. And I think it powers a lot of successful things. Just being able to laugh.

[Read more](#)

[Watch Video](#)

Image provided by Vyaire Medical





EXPLORE THE POSSIBILITIES

Windy buildings and melting cars

Using simulation to stop skyscrapers affecting the local environment
By Luke Morris

There's a huge amount of work that goes into the design and building of a skyscraper.

Safety is paramount, naturally. Architects must ensure that they can withstand wind, rain, and any other elements thrown at them. Heating and cooling systems must be incorporated into the design, along with staircases and elevators offering easy access and emergency exits.

But have you ever thought about external safety and comfort factors?

At some point, you've probably experienced the 'wind tunnel' effect in the vicinity of tall buildings. This has become more of a problem as cities such as London have seen a rapid growth of skyscrapers in the 21st century. When the 20 Fenchurch Street Building, better known as the Walkie Talkie, was

built, there were complaints about the strong gusts at the base of the tower. One person even said they nearly got blown over as they were walking past. And the tallest building in Leeds, 32-storey Bridgewater Place, was responsible for a death in 2011 when strong winds toppled a lorry parked nearby.

So, what is it that causes this phenomenon and what can be done to prevent it?

Downdraught, gusts, and channelling

High winds are created around tall buildings by what's known as the 'downdraught effect'. This occurs when wind hits a building and, with nowhere else to go, is pushed up, down, and around the sides of the structure. The air forced downwards then increases wind speed at street level. Completely square cornered buildings create a further acceleration of wind around the sides that can be dangerous for pedestrians. And several

towers standing together cause the air to be squeezed through a narrow space in an effect known as 'channelling' - this is a form of the Venturi effect, named after 18th-19th Century Italian scientist Giovanni Battista Venturi.

The strongest gusts are created when the wall it hits is facing the prevailing wind - in Britain, this is from the southwest. And London is more susceptible to channelling than cities such as New York as much of its layout is based on medieval street patterns. These narrow roads are much more likely to trap the wind than the wider streets of more modern cities. Combine all these factors and you have the potential for the extreme winds capable of blowing vehicles and pedestrians over, leading to injury and even death.

One solution is to build more rounded buildings, such as London's Gherkin. As there is less flat surface the downdraught effect is reduced and

there are no sharp corners for the air to accelerate around. But the customers that commission these skyscrapers don't want to be forced into major design decisions like this. Aesthetics are crucial to architects winning projects, so they need to find the right balance between looks and safety.

As concerns over the dangers of wind tunnels have grown, the City of London has introduced stricter rules on new skyscrapers. These require developers of towers more than double the height of surround buildings to carry out both wind tunnel testing and computational fluid dynamics (CFD) assessment. If necessary, experienced wind engineers must be consulted to confirm the findings of the tests and provide assurance that there will be no dangerous effects created.

Wind engineering

In 2019, Joe Osman, Robin Stanfield, and Alex Turpitt founded ArcAero, a specialist wind

engineering consultancy. Having worked together in wind engineering services for over a decade they contributed to projects including the London 2012 Olympic Park, Manhattan Loft Gardens in London, Mercedes Benz Stadium in Atlanta, and London's Gatwick Airport. With their vast experience they wanted to provide building developers with a solution to all their wind engineering challenges.

ArcAero's goal is to enable clients to design and deliver architectural structures that are aesthetically pleasing, comfortable and safe. They knew that wind tunnel testing, whilst essential, is very costly and time consuming so from the start they planned to use more CFD testing.

Having worked in the industry for so long, they were clear on what they needed from a CFD solution. They chose Simcenter STAR-CCM+ due to its capabilities for high fidelity, fast turnaround, and powerful workflow automation. As Joe Osman puts it, "Workflow automation is key for us to create a robust and repeatable process with minimal scope for human error."

To begin the CFD process, the geometry first must be prepared for pre-processing. Due to this coming from clients in a wide range of CAD formats it can take several days or weeks to clean up and repair the data to extract enough detail to model the development and surrounding area. ArcAero uses the built-in surface repair tool in Simcenter STAR-CCM+ to reduce this to a single day or less. It can all be done with just a few clicks, allowing them to focus on the rest of the project whilst the geometry preparation is automated.

And the automation doesn't stop there. ArcAero has developed a process using Java so that all the remaining simulation setups and pre-processing are done automatically, meaning most models are ready to run with 10 minutes once the CAD data has been prepared. "We spend minimal engineering time on the interface," Osman explains. "This allows us to focus on results rather than CFD and the process behind it."

Take Lower Essex Square in Birmingham as an example. A CFD model was built and run quickly using this automated process to predict wind hotspots that were likely to be created. They then verified these findings in the wind tunnel at Imperial College in London, leveraging the CFD simulation to visualise problematic wind patterns and explore design strategies to alleviate the hotspots. Finally, the engineers used their automated process to simulate a number of different design options in succession. These iterations continued until the optimum solution was found and this was then tested in the wind tunnel for final validation.

Power from the Cloud

The only real limit to the speed of the wind engineering process is the available computing power. ArcAero chose to use cloud computing instead of purchasing their own high-performance computer as it gave them the most flexibility whilst maximizing performance and minimizing cost.

"With varying demands in project workloads, cloud computing offers a cost-effective and flexible option in comparison to on-premise hardware," Osman explains. This was another reason for choosing Simcenter STAR-CCM+ as it can be used on the Gcompute cloud platform. Osman estimates that this allows them to get results within 30 minutes compared to two days if they were using a local computer. The Gcompute platform enables seamless customization and integration of STAR-CCM+ scripts to tie in with the entire automation process. This gives ArcAero a higher level of control and delivers a robust, repeatable process.

Cloud computing is perfect for a growing business like ArcAero as it avoids large capital expenditure on hardware and allows them to flex up or down as required. "Cloud enables our company to handle large fluctuations in capacity as we scale up and pay for what we use, which perfectly suits our highly variable throughput," says Robin Stanfield. He goes on to explain how



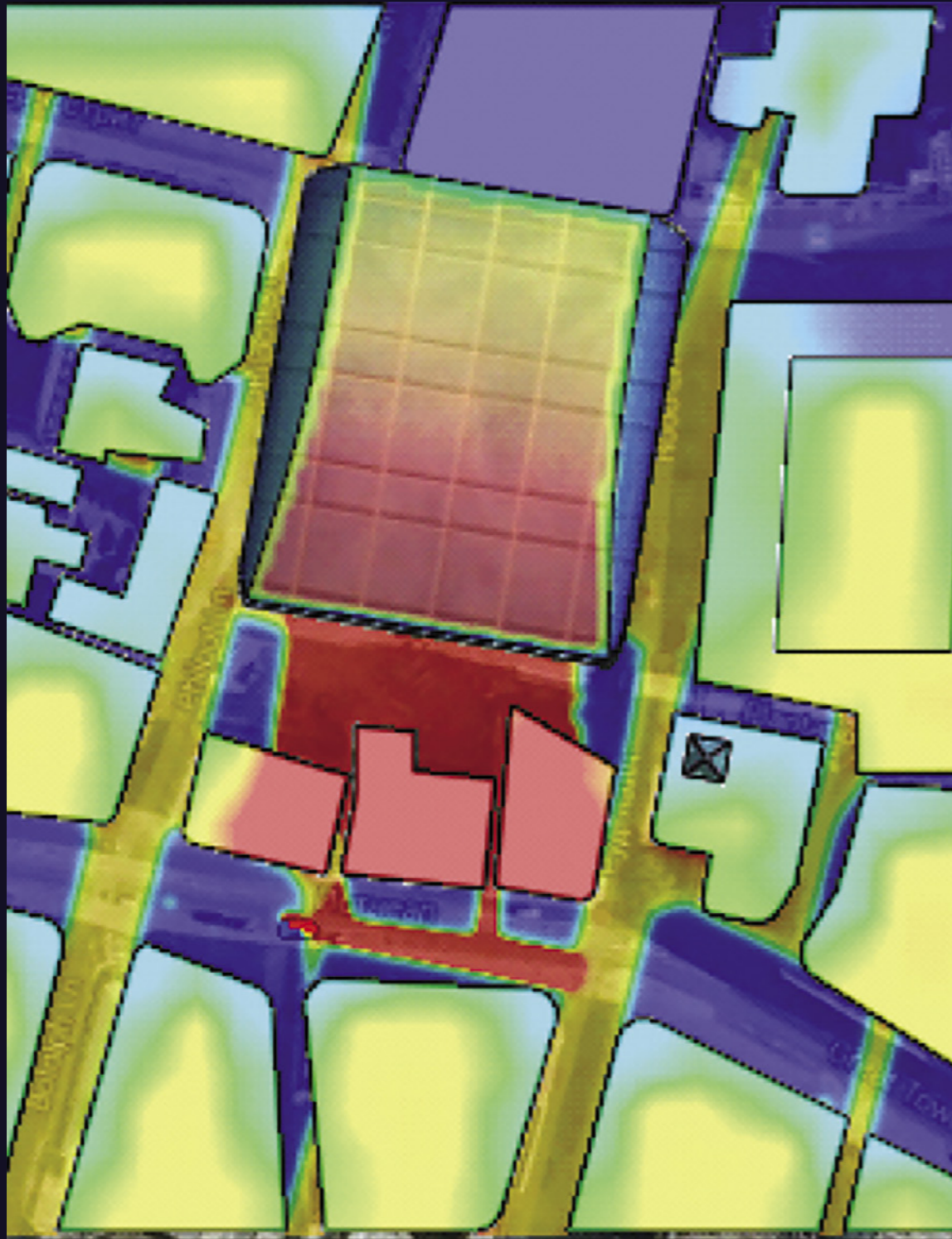

Simulation is an essential component of the skyscrapers of the future. The technology available now enables engineers to predict problems early in the design process and work with architects to find the ideal solution.

parallelization and flexible licensing make this the ideal solution. "Cloud hardware allows us to get the most of our licensing costs. We can run virtually unlimited simulations simultaneously. This reduces the turnaround time and allows us to do more thorough exploration of the design space and help our customers to a better solution."

Protecting against all elements

Wind isn't the only problem skyscraper developers face.

Did you hear the one about the building that melted cars?

Yep, it was the Walkie Talkie again.

On August 29th, 2013, when the building was nearing completion, Martin Lindsay parked his Jaguar on Eastcheap in the City of London. Two hours later he came back and found part of the car including the wing mirror and badge had melted. On the windscreen was a note from the construction company saying, "your car's buckled, could you give us a call?" The developers accepted responsibility and paid the repair costs of just under £1000.

But how did this happen?

Dr Svetlana Shtilkind, Dr Andrey Ivanov, and Maxim Popov from Siemens Digital Industries Software used Simcenter FLOEFD to investigate the phenomenon.

They began by creating a full-scale CAD model of the building and surrounding landscape, taking area topology data from Google Maps. The solar radiation parameters (location and time) were specified using Simcenter FLOEFD and automatically included in the simulation.

They estimated the ray-exposed area dynamics as a result of the sun's position on August 29th and determined that the most heated area at the time of the incident was the section of Eastcheap where the car was parked. The sunlight focus area was then placed in the CAD model and a more exact car position was defined by the focus trajectory analysis.

By defining the relevant areas of the building and the car they were able to simulate the melting that occurred. This showed that the solar influence on the car's bonnet (hood) and wing mirror peaked at 12:40 at around 1,300 W/m². This is around 1.5 times higher than the average solar radiation flux value relative to the location, day, and time. The solar influence on the wing mirror lasted just ten minutes, but due to the extreme temperature and the hollow construction with a thin plastic outer shell this was enough for it to melt.

The investigation found that it was in some ways fortunate that the damage was relatively minimal. It compared the results of the reflection from the parabolic glass of the Walkie Talkie with more reflective material. In the case of total or mirror reflection, the Simcenter FLOEFD simulation reported a maximum flux value of 6,000 W/m². An extreme scenario that would undoubtedly have much more serious consequences.

The future of skyscrapers

Clearly, skyscrapers aren't going anywhere. Except up.

Inherent in human nature is the desire to build bigger and better. To push the limits of architectural imagination.

But as larger and more elaborate structures are built, more phenomena caused by the local environment will be uncovered.

With the costs involved in designing and constructing skyscrapers, developers can't afford the prospect of being forced into an inordinately expensive redesign or even the complete removal of a building.

Simulation is an essential component of the skyscrapers of the future. The technology available now enables engineers to predict problems early in the design process and work with architects to find the ideal solution. Combined with wind tunnel testing to validate simulation results, we can all be assured that as well as looking impressive, modern skyscrapers will pose no danger to people and property in their vicinity.



Let's engineer innovation with Simcenter

Meet Anooch Hegde, a Simcenter research engineer who is stretching the boundaries of what is possible to help deliver on the promise of net-zero travel. Join him to discover your power to change the world.
[siemens.com/simcenter](https://www.siemens.com/simcenter)

SIEMENS

STAY INTEGRATED

Letting electricity do the heavy lifting

Reducing heavy equipment power consumption
and improving performance with simulation
By Luke Morris



Image provided by
Haulotte



Image provided by Haulotte

When it comes to heavy equipment, safety is absolutely vital. As is performance, efficiency, and emissions control.

Construction sites are potentially dangerous places that need to stick to tight schedules and budgets. So, they only want to use the safest, most reliable, and most economical equipment.

A common piece of heavy equipment seen across construction sites is the scissor lift used both indoors and outdoors to provide an elevated platform for workers. It needs to be able to cope with all sorts of terrain – muddy, uneven, sloped – without risking user safety or compromising performance.

Historically, these lifts have been powered by internal combustion engines that can meet the demands and pressures that they are expected to deal with. However, as construction sites strive to be more environmentally friendly and stricter regulations are imposed by local authorities, demand has grown for alternative solutions powered by cleaner energy.

Enter Pulseo by Haulotte, a range of next-generation, all-terrain electric scissor lifts.

But switching from a thermal engine to an electric motor without losing any performance is no easy task. It requires so much more than simply swapping power units. Transitioning from thermal to electric demands analysis of the entire equipment architecture to optimize it for a completely different power system.

And Haulotte didn't want to produce an electric lift that was merely as good as older models. They wanted it to be even better.

To meet this challenge, Haulotte turned to simulation to help them design and develop the ultimate electric scissor lift. We recently spoke to Arnaud Chaigne, head of the Simulation and Digital Validation Division at Haulotte to find out why simulation was the solution and what the end results were.

Understanding the old to optimize the new

To define the optimal system architecture for the electric lift, Chaigne's team had to ensure the battery was sized correctly. As power requirements fluctuate during operation, there's always a risk of oversizing to ensure the machine can cope during moments of peak power demand, but this would compromise on overall performance.

Simcenter 3D Motion allowed for the modelling of the forces in the hydraulic actuators that raise the

platform. By taking into account kinematics, mass distribution, friction, and dynamic effects, engineers got full insight into the pressure level details and the energy that the actuators need to do their job. This showed Chaigne and his team that the peaks in demand occurred at the very beginning of elevation when the lift started to rise.

"We started by modelling the existing thermal system in order to identify the most energy consuming parts (energy-loss mapping). By doing this, we were able to define a new architecture more suited to an all-electric machine where all energy consumption counts," Chaigne explains. "In order to optimize the battery size, we had to develop control laws to smooth out the power peaks while offering a similar lifting time. This resulted in a constant power level during the entire elevation movement."

Using Simcenter Amesim, they then studied a multitude of design possibilities and predicted the machine performance of each one.

"Simulation allowed us to assess the feasibility of different innovation scenarios, taking into account the impact

on various systems, like hydraulics, electrics and controls, as well as machine stability and operator safety."

Keep it steady

Simcenter 3D Motion was also used to ensure the stability of the lifting mechanism both during transit and in operation. Regulations are in place to guarantee worker safety on and around elevating lifts. These stipulate that not only must they be stable when workers are on the platform, but also when the equipment is being moved into position.

The Haulotte engineers needed to anticipate all possible scenarios by studying the behaviour of the scissor lift – in particular that of the oscillating axle. Chaigne says that Simcenter 3D Motion was the perfect tool for this. "We used Simcenter dynamic multibody simulation to size the scissor lifts to ensure stability. This made it possible to find the best compromise between performance and machine weight and save time during development."

Co-simulation delivers the best results

Co-simulation is a technique where global simulation of a coupled system can be achieved by composing the simulations of its parts. Simcenter's wide portfolio of software enables

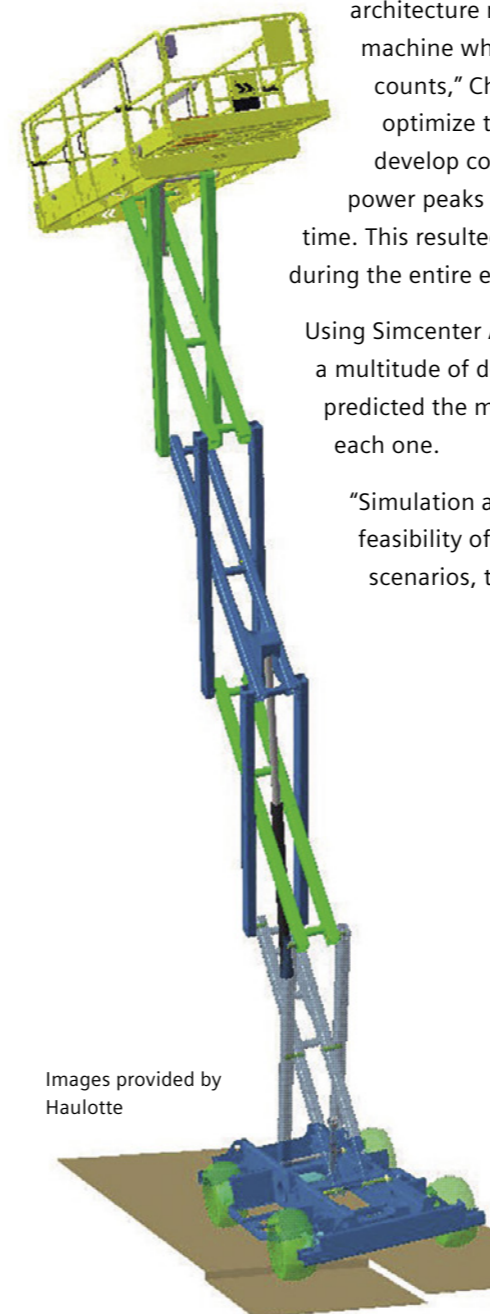

Images provided by Haulotte

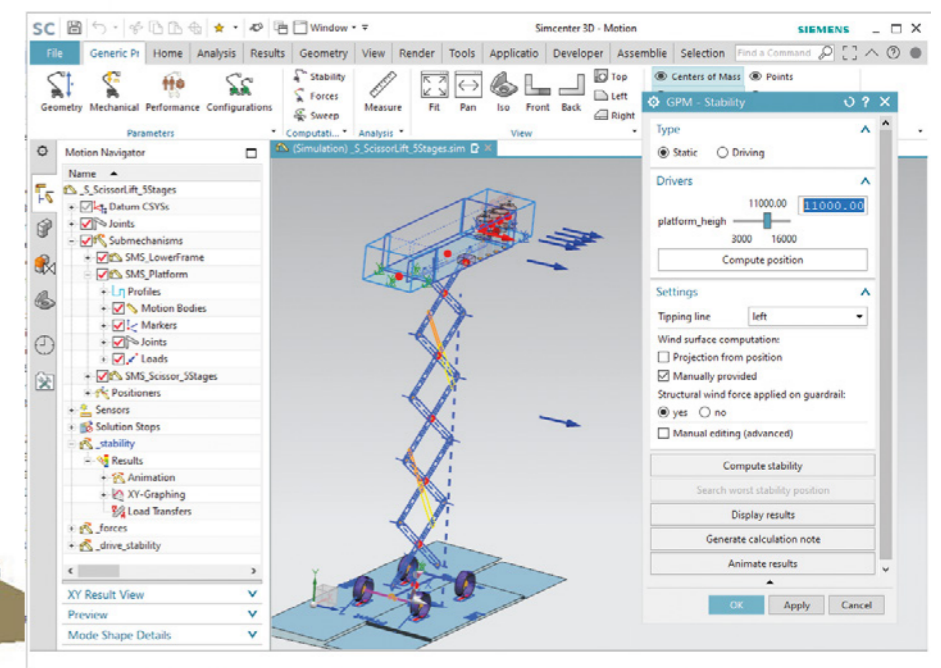



Image provided by Haulotte

co-simulation by allowing for the easy exchange of information between each tool.

For the Pulseo range, Haulotte engineers used Simcenter 3D for structure and stability analysis and Simcenter Amesim for energy analysis and battery sizing. “Firstly, the two software programs operate simultaneously and exchange information to converge toward a common solution,” Chaigne explains. “We also use Simcenter 3D Motion to generate force tables according to the cylinder position. This information is then transferred to and used in Simcenter Amesim.”

Chaigne notes that analysing the pressure balance in the hydraulic actuators and the resulting stress distribution is key to improving performance. “Co-simulation allows us to analyse the stresses under normal conditions and during failures. We can see how the load transfers take place and the impact on hydraulic cylinder pressure.”

Democratizing simulation

In the past, use of simulation models has been restricted to specialists due to their complexity and the need for a full understanding of the tools involved. This has slowed down development as teams have had to wait for these specialists to process information at key stages of projects.

But this is changing thanks to what has become known as the ‘democratisation’ of simulation

“As a simulation expert, I am responsible for making sure our simulation tools are accessible,” says Chaigne. “The customisation possibilities in Simcenter 3D via NX Open have made it possible to integrate our business rules and regulatory norms to speed up the calculation process and reduce the risk of error.”

In the case of stability analyses, the team must work to standard norms which vary between regions. Each will have different requirements for environmental, operator impact, and equipment handling factors. To improve and speed up the analysis process, Haulotte has developed a customised process-oriented workflow tool using

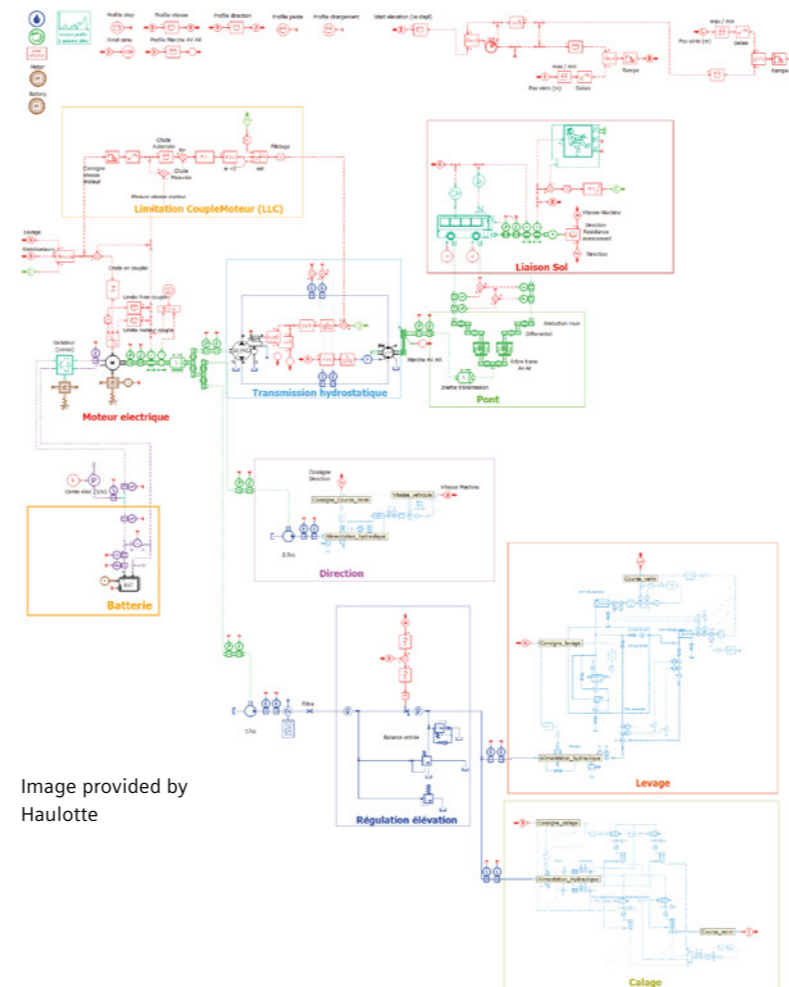

Image provided by Haulotte

the NX Open software automation module for Simcenter 3D. In short, this allows them to automate data entry taking into account the various norms of different regions. Chaigne explains, “During post-processing, it provides clear-cut stability information. This enables non specialists to use more complex Simcenter 3D Motion models.”

Lower costs, improved performance

The success of simulation has meant that Haulotte has been able to save both time and money by reducing the amount of physical testing required. Chaigne notes that the test phase remains essential but is much more streamlined thanks to Simcenter. “Simulation helps us identify the most critical cases in terms of stability, evaluating

parameters like machine position, loads and forces.”

And when testing does highlight issues, simulation provides a deeper insight into the cause and helps to find the solution. “To reproduce the performance accurately, you have to model different physical phenomena. This includes identifying influential parameters and evaluating alternatives immediately. Working like this, we can reach the prototyping phase with a more mature, even definitive architecture.”

But what about the performance of the final product? Let’s compare past with present.

The older internal combustion powered lift had a 23kW thermal engine, maximum working drive height of 12m, and a loading capacity of 500kg.

Haulotte’s Pulseo lifts are powered by a 12kW electric motor. The working drive height has increased 25% to 15m and the loading capacity has increased by 50% to 750kg.

That’s a huge performance increase and an equally huge reduction in power. Of course, the new scissor lifts comply with all the operational stability safety standards across different regions. And thanks to being electric, they’re pollution-free and much quieter, enabling them to meet any noise and carbon emission regulations.

So, if you were thinking that some heavy equipment requires too much power to switch to electric energy, think again. Harness the power of simulation and you’ll start to see things very differently.

STAY INTEGRATED

Straddling the Kármán line

Getting results both inside and outside Earth's atmosphere

By Luke Morris

The Kármán line, named after Hungarian American engineer and physicist, Theodore von Kármán, is the boundary between Earth's atmosphere and outer space. Broadly, most experts say that space starts at the point where orbital dynamic forces become more important than aerodynamic forces so designing structures or aircraft to be used on our side of the line typically requires different types of testing and analysis to those on the outside. But it's still possible to use

the expertise of the same engineers on both sides if you have the right tools for the job.

Expanding the International Space Station

The Bartolomeo platform, produced by Airbus, is the newest payload hosting platform designed to explore the potential commercial use of the International Space Station (ISS). When it came to the critical and complex testing phase of the project, Airbus turned to DLR for help.

The Institute of Aeroelasticity, based in Göttingen, is part of Germany's space agency, Deutsches Zentrum für Luft- und Raumfahrt (DLR). It is a leading research centre that focuses on structural dynamics, unsteady aerodynamics, and dynamic loads. Traditionally, it has worked on aircraft,

including ground vibration testing (GVT), multi-axis vibration excitation, and test rigs for wind tunnels, but more recently has evolved to include modal survey tests (MST) for the space industry.

DLR used the 192-channel Simcenter SCADAS Mobile hardware equipment for a modal survey test to update the finite element simulation model of the Bartolomeo platform. This was crucial to the project as it allowed for the simulation and prediction of aspects such as how the platform would couple with the ISS. Reliability and accuracy were vital as in space the tiniest miscalculations can have serious consequences. Simcenter SCADAS Mobile enabled the capture of accurate experimental data to validate and improve the fidelity of the FE model by measuring 192 signals simultaneously.

Having recently switched from Simcenter SCADAS 3 to Simcenter SCADAS Mobile this was DLR's first major application of the new system, but as Julian Sinske, Structural Dynamics Testing Lead, says, they had no doubts in its capabilities. "In our experience, Simcenter SCADAS has always been issue-free and reliable, so we were extremely confident in the updated system."

Fully customizable

Sinske says that Simcenter SCADAS Mobile provides extra flexibility for handling not only MST, but different types of tests such as GVT thanks to the versatility of the data acquisition system. He also points out the advantages of using it alongside another tool from the Simcenter portfolio: "Simcenter Testlab is well-suited to large-scale tests like this one, particularly with the flexibility to customize what it offers."



Image provided by Airbus

This customization allowed DLR to run its own algorithms alongside Siemens' PolyMax algorithm to satisfy their specific testing needs. DLR engineers also customized the user interface and projected the results onto the wall of the laboratory so that everyone could track test progress. This all led to significantly quicker results than comparable testing scenarios, with the first measurements available less than an hour after setup.

Delivering results fast

The complete test results were delivered in less than four days – unprecedented based on previous projects. The structural dynamic data set produced by DLR enabled Airbus to determine the appropriate modal model, identify nonlinearities, and update the finite element model.

"Airbus had very high expectations," Sinske says, "which thanks to having the right tools available to us, we were able to meet. The entire test went according to plan. We needed to work as fast as possible to swiftly deliver the data that was required. Simcenter SCADAS Mobile and Simcenter Testlab helped us achieve this."

The future has just begun

Now they've done it once, the engineers from DLR's Institute of Aeroelasticity will be able to do it again and again. They've created a replicable testing approach that can be used in either aviation or space. "We use the same hardware and software for both GVT and MST and we have a plan in place," says Sinske.

But they're not standing still and basking in their achievements. DLR is already hard at work developing new testing methods and technologies for the future, including the use of automation and artificial intelligence.

So, whichever side of the Kármán line a project is focused on, DLR now has a blueprint for fast, effective, and reliable testing. And it's all thanks to the agility of Simcenter SCADAS Mobile and the flexibility of Simcenter Testlab.



Take a **virtual tour** with us

The transition to autonomous and electric vehicles means that engineers are expected to optimize the vehicle energy management (VEM) of more interconnected/mechatronic systems than ever before. All these systems need to balance the energy entering the vehicle in the most sustainable way possible.

Our VEM facility in Lyon, France helps automotive companies achieve their VEM targets in order to meet environmental regulations without compromising vehicle performance. Our virtual tour guides users through this facility so they can see our team and facility in action.

<https://www.plm.automation.siemens.com/global/en/resource/vehicle-energy-management-facility-virtual-tour/101130>

SIEMENS

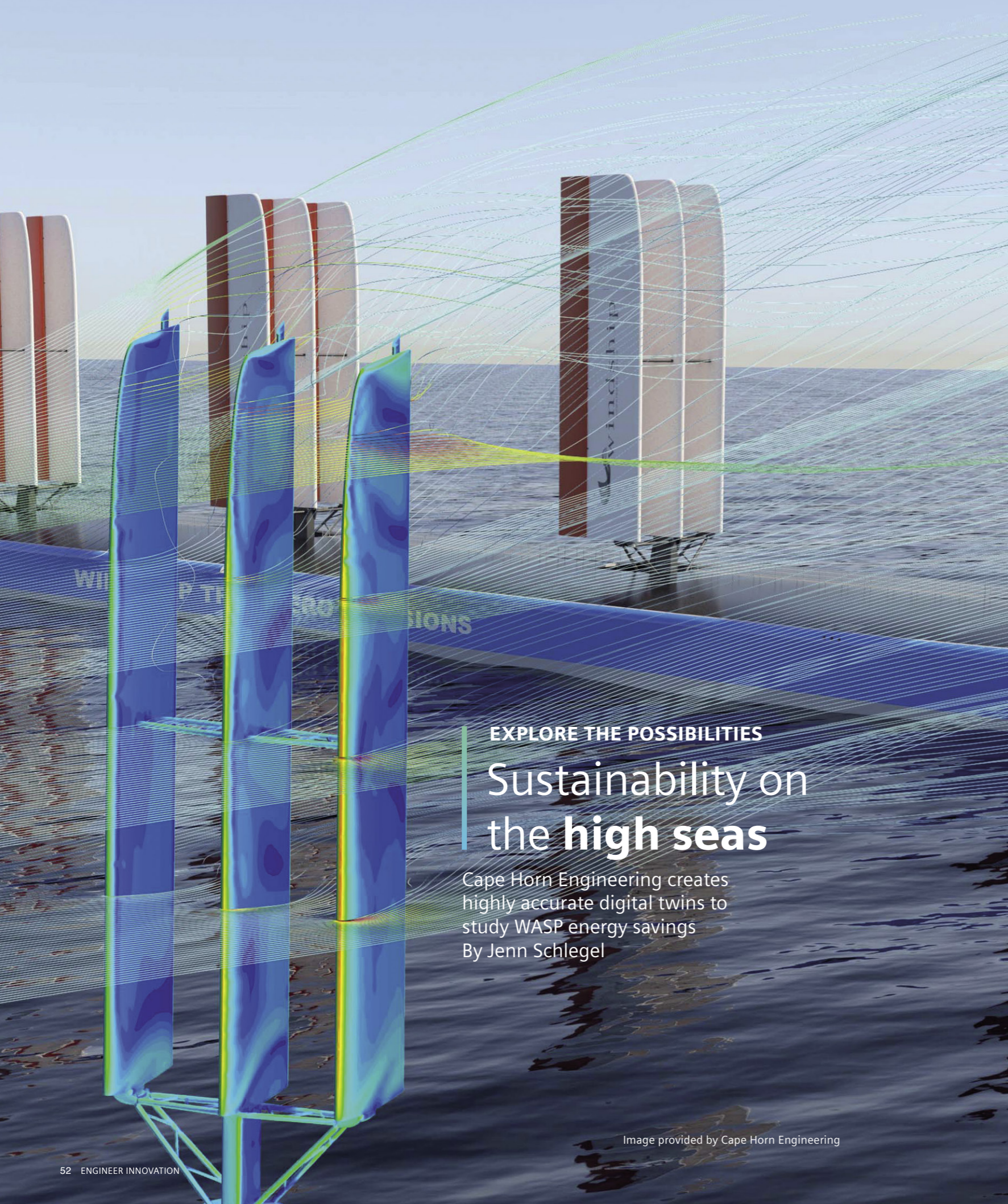

EXPLORE THE POSSIBILITIES

Sustainability on the high seas

Cape Horn Engineering creates highly accurate digital twins to study WASP energy savings
By Jenn Schlegel

Image provided by Cape Horn Engineering

The silent green revolution in marine

Sustainability is king across practically every industry today, from automotive, aerospace and energy to consumer goods and food. Although slightly slow to start, the green revolution has taken the greater marine industry by storm. Cargo vessels and cruise ships are being refitted with more sustainable propulsion systems. Next-generation vessel designs are incorporating new wind and solar technology. With new regulations on the horizon, energy efficiency and improved performance are a top priority when it comes to naval architecture and vessel design of all shapes and sizes.

One needs to remember that creating a ship, especially a complex one like *Wonder of the Seas*, currently the largest cruise ship, is an entirely different ball game than designing a simple four-door family sedan. There could be millions of extremely large and complex parts, components and systems to integrate on something as immense as a cruise ship or specialized marine vessels like an LNG carrier, a polar research vessel or a CTV (crew transfer vessel). Ships run into the hundreds of millions of euros as investments with lifespans of 30-plus years in many cases. When you start to design complex and expensive vessels like these, every cent that you can shave off by enhancing energy efficiency contributes to reducing the overall cost of operation and long-term sustainability of the marine sector – not to mention the overall environmental impact of reduced emissions and global warming.

The brainchild of Dr.-Ing. Rodrigo Azcueta, a naval architect and Computational Fluid Dynamics (CFD) expert, Cape Horn Engineering is a world-renowned CFD consultancy based in Portsmouth, with a serious racing pedigree; heading the CFD technology for four America's Cup Challenges and conducting performance analysis for yachts in the world's most prestigious races including the Volvo Ocean Race, the Vendée *Globe*, and the Transat Jacques Vabre.

As industry leaders in CFD and marine technology solutions, they specialise in performance prediction of racing yachts, sailing yachts, superyachts, motor boats, commercial ships, renewable energy structures and more.

CFD for a Greener Marine Future

The specialist team at Cape Horn Engineering is dedicated to achieving sustainability throughout the marine sector, helping naval architects around the world successfully reduce emissions, and improve energy efficiency by implementing new, more sustainable energy sources and analysing design options.

One of the key new technologies they use is a simulation process to make sure that a ship design meets or exceeds the upcoming Energy Efficiency Existing Ship Index (EEXI) regulations. The International Maritime Organization (IMO), a specialized United Nations agency, has set a policy framework to reduce carbon intensity by at least 40% by 2030, and a total greenhouse gas emissions by 50% by 2050. The first measures, namely the Carbon Intensity Indicator (CII) and the EEXI come into force on January 1, 2023.

While CII is an operational measure, assessing how efficiently a ship transports its cargo according to real-time fuel consumption, EEXI is a technical measurement that purely considers the vessel's design parameters. It is comparable to the Energy Efficiency Design Index (EEDI) for newbuilds. The EEXI measures the design CO₂ emissions relative to the vessel's size and speed and translates this to emissions per cargo ton per mile. The IMO has set limits regarding the allowable EEXI according to

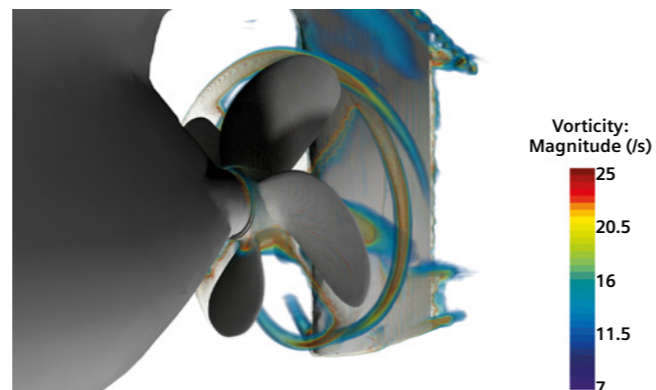
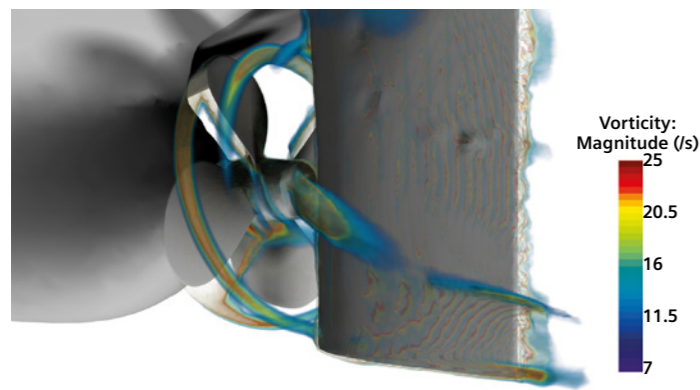

Image provided by Cape Horn Engineering

vessel size and type. Every ship will be required to comply with the EEXI next year.

"Embracing CFD technology gives ship owners a cost-effective means by which they can explore a range of solutions to ensure they are on target to meet the upcoming EEXI regulations. It also provides the ideal environment to test and optimize novel energy saving devices, such as wing sails. There are several possible solutions which must be considered to reduce the environmental impact of the shipping industry, each of which has a very important role to play," explains Dr.-Ing. Rodrigo Azcueta, Managing Director, Cape Horn Engineering.

CFD for a Greener Marine Future

CFD simulation software by Simcenter, can help calculate the EEXI for older vessels by developing speed power curves to update existing documentation. This is a much faster and more efficient method than traditional towing tank testing. Another area where CFD is beneficial, is when engineers need to investigate potential energy efficiency improvements, such as adding Wind Assisted Ship Propulsion (WASP) devices and calculating their impact on the EEXI. To meet the new regulations, several ship owners are considering WASP devices, such as wing sails, suction sails and Flettner rotors...to name a few.

"WASP devices can potentially cut fuel costs by 10 to 30 percent, but they are highly complex systems to model. Both the hydrodynamic and aerodynamic effects need to be modelled

simultaneously in a single simulation. We have developed a simulation workflow to directly compare WASP device efficiency and determine potential savings. Wind conditions above the water surface are modelled with an accurate wind profile taking into account the atmospheric boundary layer wind gradient," explains Dr.-Ing. Azcueta.

Comparing WASP technology with digital twins

With simulation technology, naval architects and engineers can investigate the performance of different WASP options virtually, to make the most effective choice according to the vessel's requirements.

Of course, result accuracy is always important, which is why engineers need to be sure to quantify and understand the simulated CFD results via a solid verification and validation process. Today, with increased computer power and more accurate software and processes, digitalized versions of vessels are reflecting real-world performance quite accurately. This is what is referred to as a **digital twin**.

To showcase this solution, Cape Horn Engineering developed a case example comparing two WASP configurations on a 138m general cargo vessel, the MV Regal. Benchmark data was readily available for the MV Regal, making it an obvious choice for verification and validation of the process.

The first option examined consisted of two three-wing-three-flap wing sails mounted on the deck.

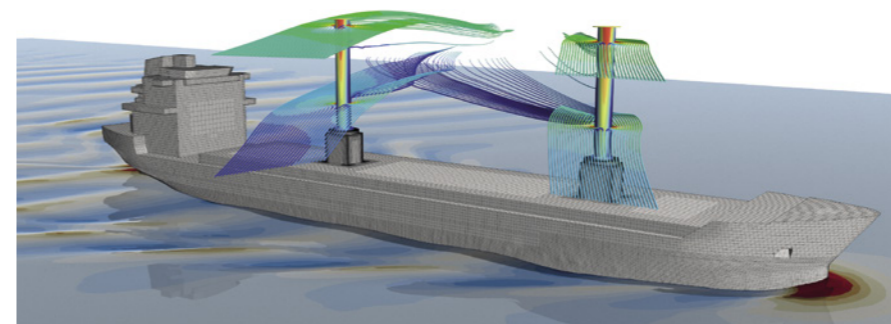
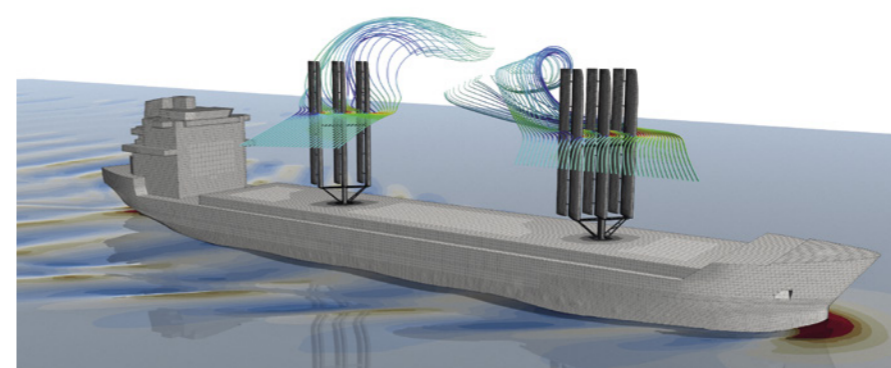

Images provided by Cape Horn Engineering

The second option replaced the two wing sails with two similar-sized Flettner rotors.

"We didn't aim to compare the WASP technology itself, but rather demonstrate our simulation set-up as a feasible way to compare different types of WASP devices with a highly accurate all-in-one, 6 degrees-of-freedom hydrodynamic and aerodynamic simulation, based on Simcenter software," explains Dr.-Ing. Azcueta. "Even unoptimized, there was a 14 and 24% power reduction thanks to the WASP devices. This tool can clearly help ship owners make an informed decision when it comes to retrofitting their vessels for energy savings."

Enter Artificial Intelligence

Modelling wing sails under realistic conditions can be accurately done, but it still takes super-computer capacity to run these types of simulations, especially when optimization loops are included. In an ideal world, the simulation runs for a study like this could hit the hundreds or even thousands of computed simulations. To address this issue, Cape Horn Engineering is

working together with several companies and universities to train AI models to use reduced order modeling and design neural networks to compute the aerodynamic forces in seconds rather than hours.

"Incorporating AI into the picture opens vast possibilities to optimize the wing sail design and develop intelligent control systems to ensure the largest possible reduction in emissions," adds Dr.-Ing. Azcueta.

He concludes, "Our niche area of CFD expertise has so much potential to offer greener shipping solutions. It is not often that your interests align in such a way, so it is an exceptional and exciting opportunity for everyone involved. Collectively we can make a difference on a global scale."

About Cape Horn Engineering

Cape Horn Engineering is a UK based company, best-in-class independent CFD (Computational Fluid Dynamics) consultancy with clients all over the world. Industry leaders in CFD and marine technology solutions, specialising in performance prediction of racing yachts, sailing yachts, superyachts, motor boats, commercial ships, renewable energy structures and more.

CFD technology is a crucial support for naval architects, yacht designers and design engineers to optimise designs for critical elements such as weight saving, performance predictions, reducing emissions and design optimisation.

Using their extensive experience, they offer unique solutions and insight into how this revolutionary technology can assist designers to improve performance and efficiency, leading to considerable fuel and emission reductions.

<https://www.cape-horn-eng.com>



MODEL THE COMPLEXITY

Step by step

Helping stroke patients regain mobility
By Kate Foster

“It just an average day,” Anna recalls. “The usual ups and downs at work, a gym class, then a glass of wine with a friend on the way home, nothing extraordinary.” But it was just as Anna had curled up on the couch to scroll through her social media feeds and catch up on her messages that she realized that the day had been anything but ordinary for family friend, Peter. “There it was: a group chat message saying that Peter had suffered a stroke that morning and was in hospital. I automatically thought of the last time I saw him at a get-together, just a week ago; he was tending to the barbecue and telling us about his upcoming ski trip. I was just shocked. It was hard to imagine him as a stroke patient.”

Anna’s reaction highlights the intrinsic nature of such medical events. They are so sudden, so quick, so seemingly indiscriminate. Strokes, or cerebrovascular accidents (to use medical terminology), are life-changing moments that strike the patient down, often out of the blue. Recovery is a long process. For many sufferers, this involves relearning even the most taken-for-granted actions, like walking and talking.

A growing challenge

It’s a story that, across the world, is all too common. The World Health Organization (WHO) estimates that 15 million people per year suffer a stroke[1]. Often, a stroke results in brain damage due to the sudden reduction in blood flow to the

Explainer: What happens during cerebrovascular accidents?

Put simply, a stroke is an attack on the brain; when the blood supply to part of the brain is cut off, it causes damage to brain cells and results in impaired neurological and physiological functioning. This can present as paralysis down one side of the body (hemiplegia), muscle weakness and imbalance, speech problems and changes in sensation.

Source: Stroke Association, <https://www.stroke.org.uk/effects-of-stroke/physical-effects-of-stroke>

brain cells. It is estimated that, after three months, 20 percent of people who lost mobility as a result of a stroke remain wheelchair bound, while approximately seventy percent of sufferers walk at reduced velocity[2]. In many cases, patients undergo a lengthy and gruelling period of rehabilitation in order to re-establish the muscle strength, balance and range of mobility that they lost.

The reality is that stroke rates are increasing. According to a 2020 research report[3], the number of people living with stroke is estimated to increase by 27 percent between 2017 and 2047 in the European Union, mainly because of population ageing and improved survival rates. And given the prevalence of neurological and physiological damage following a stroke, the need for effective rehabilitation methods is acute.

But for stroke patients like Anna’s friend Peter, there is some positive news. Modern rehabilitation methods are embracing not only proven repetitive,

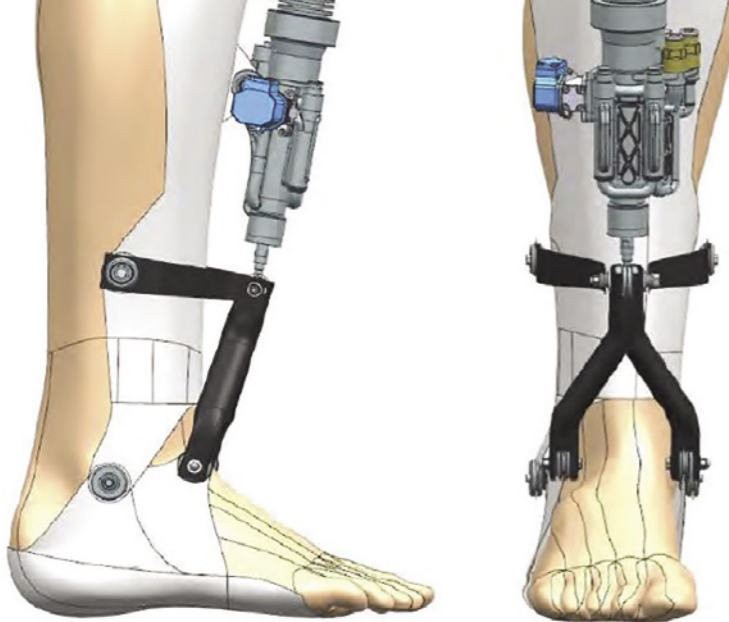

Image provided by HEIA-FR university

task-specific approaches, but also cutting-edge technologies that are enabling people to walk again and re-establish their independence and quality of life more quickly. Much research is being done in this area and the technological advancements that are emerging in this space are encouraging. One such field is that of robotic exoskeletons, wearable mechanized devices that assist gait rehabilitation by amplifying and assisting natural motion.

Wear and walk

Many stroke patients are already benefitting from robotic exoskeletons, which offer numerous benefits along the road to regaining mobility. They allow for more effective physiotherapy sessions, greater patient comfort, and can even provide quantitative information about the patient's recovery such as velocity, smoothness and range of motion[4]. Various clinical studies have suggested that the use of exoskeletons in rehabilitation therapy can offer greater biomedical benefits than more traditional, passive orthoses such as braces and supports.

But while this burgeoning field of biotechnology is rapidly gathering pace, robotic exoskeleton design is still in its infancy, with many practical challenges like mass and size to overcome.

So, how are engineering teams around the world working to advance exoskeleton designs and take this life-changing technology forward?

Innovating the exoskeleton

When mechanical engineer Emmanuel Viennet was starting out in his career, medical science

couldn't have been further from his mind. He spent three years as a simulation engineer in the field of vehicle transmission systems, before coming to specialize in hydraulics. These days, he is a professor of mechanical engineering at Switzerland's HEIA-FR university and, through his work in fluid power technology and system simulation, is helping advance stroke rehabilitation technologies like exoskeletons in novel ways.

"Our current project focuses on the development of a hydraulic actuator for an ankle exoskeleton that would be used by stroke patients in rehabilitation settings," he explains. The project—named Talaris after the winged sandals of Hermes, the Greek messenger god—investigates harnessing fluid power technology, which uses the natural flow of pressurized fluid as an energy supply to a hydraulic system as a means of powering the lower-limb device. This represents a departure from common exoskeleton designs relying on electric motors which can be noisy, heavy and bulky for the wearer[5].

The design challenge for Viennet and his team was to build a demonstrator of the innovative hydraulic-powered concept—but within the limitations of the university department's finite financial resources. The nature of the concept also posed tough questions around testing. Viennet says his team generated around a dozen viable a priori variants by combining different hydraulic architectures, distribution principles, actuator types and energy storage components. But with the means to only build and test a maximum of two solutions, how would his team choose between pump-controlled or valve-controlled distribution, or decide on the best kind cylinder type?

This was where Viennet's background as a simulation engineer came into play and resulted in him introducing Siemens Simcenter to this ground-breaking project. Using Simcenter Amesim, a powerful software for modelling and analysis of multi-domain systems, the Talaris team was able to evaluate their potential designs with

ease in numerical simulations and preliminary tests, then make decisions with confidence.

"Thanks to Simcenter Amesim, we could narrow down our initial design ideas and thoroughly investigate our two final design candidates." Emmanuel Viennet, HEIA-FR University

Testing the possibilities

The winning design featured a servo-hydraulic actuation rather than an electro-hydraulic solution, after Simcenter Amesim helped the team identify the option for best dynamic performance based on an ankle exoskeleton to support an 80kg patient when walking at a normal speed requiring the whole system to have a bandwidth of at least 8 hertz (Hz).

"Without simulation, we would have used more classical tools like spreadsheet, which would have limited ourselves to steady state analysis. On the other hand, we would have built more prototypes to reach the same level of system understanding," Viennet says.

"Simcenter Amesim helps us by serving as a virtual test platform where design space can be narrowed down in a systematic and efficient way. In a less expected way, it also helps in providing a technology-neutral platform that can be leveraged

by users to dive into domains they are unfamiliar with," adds Viennet.

This opens the door to teams with diverse skillsets and domain expertise coming together to innovate, experiment and create. The low-risk environment simulation provides means that imaginations can be stretched to their fullest—and the potential outcomes are limitless.

In the world of stroke rehabilitation, exoskeletons are undoubtedly changing the game by harnessing technology and engineering excellence to help patients walk again while reducing the burden of lengthier recoveries for healthcare institutions. A recent review of exoskeleton technology[6] published in the Journal of Neuro-Engineering and Rehabilitation, however, saw the authors point out that wearable robotic exoskeletons—a relatively nascent approach to rehabilitation since their first use in 1994—still have some way to go in terms of optimal design. Based on a review of exoskeletons currently in use in rehabilitation setting, the report is a reminder that wearer comfort, complexity of fitting and operation and the device's ability to mimic natural gait are areas of design that must be improved in the future. As Emmanuel Viennet's work at HEIA-FR University illustrates, simulation has a central role to play in realizing those improvements.

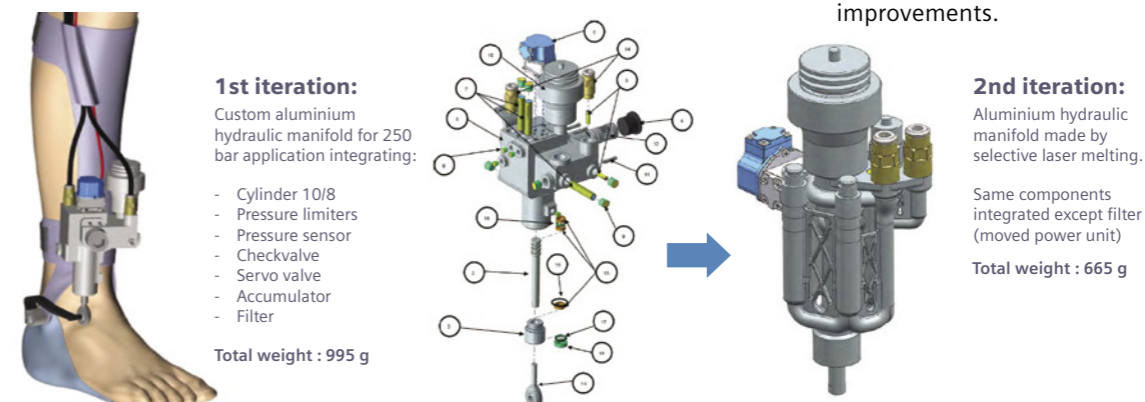

Image provided by HEIA-FR university. First concept for integration of the actuator on an exoskeleton structure and design iterations

References

1. <http://www.emro.who.int/health-topics/stroke-cerebrovascular-accident/index.html>
2. According to research by University of Applied Sciences and Arts in Western Switzerland
3. <https://www.ahajournals.org/doi/10.1161/STROKEAHA.120.029606>
4. <https://www.sciencedirect.com/topics/engineering/exoskeleton-robotics>
5. https://www.researchgate.net/publication/336519948_Development_and_Control_of_an_Electro-Hydraulic_Actuator_System_for_an_Exoskeleton_Robot
6. <https://jneuroengrehab.biomedcentral.com/articles/10.1186/s12984-021-00815-5>

STAY INTEGRATED

Why subsea compression is a keystone of the energy transition process

By Mario Vacca

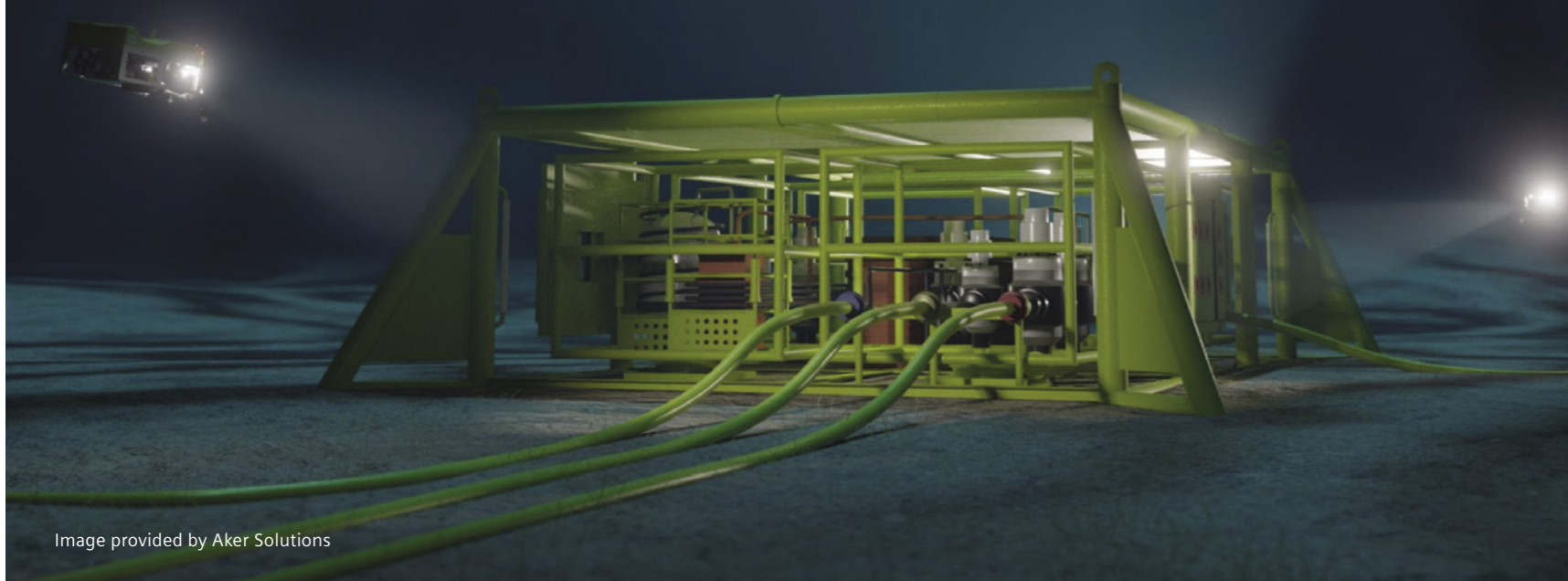

Image provided by Aker Solutions

Aker Solutions helps oil and gas operators transition to a more sustainable future.

tran·si·tion

/trən'ziSH(ə)n, trən'siSH(ə)n/

noun: transition; plural noun: transitions

"the process or a period of changing from one state or condition to another."

We're facing one of the biggest challenges of humankind: climate change. We must find solutions to counter the change and reduce our CO₂ emissions. And we need to find them quickly.

Alas, there isn't a team of superheroes who can save the planet. And there isn't – to date - a single disruptive technology that can prevent us from releasing tons of harmful CO₂ into the atmosphere.

It's all about transitioning our ways to produce energy; from technologies that damage the environment to sustainable ones. And transitions happen gradually.

Saving the planet is on us. All of us. At Aker Solutions, engineers take this challenge very seriously. The company supports energy and utilities industry players in their transition towards more sustainable operation and helps them reach their net-zero goals.

Aker Solutions relies on various innovative technologies to achieve these objectives. One of these innovations consists in designing and installing compressors on the seabed to increase the output or extend the lifetime of a subsea well.

Henrik Alfredsson, Managing Director, and Nicolas Barras, Global Pursuit Manager, Subsea Compression, Pumps and Power at Aker Solutions, explain why subsea compression is essential for a successful energy transition process.

Discover subsea gas compression

The technology is relatively new. Subsea gas compression was first introduced in the 2010s. In September 2015, Åsgard became the world's first subsea gas compression facility. A few years later, the technology is one of the most important measures for delivering important gas volumes from existing fields on the Norwegian continental shelf.

How does it work?

In a gas reservoir, the pressure naturally declines over time as gas is taken from the reservoir. Gas is a compressible element, and when the pressure depletes, it naturally occupies more space in the flow lines. As a result, the velocity of the gas through the flow line increases, which results in further pressure drop. At a certain point the flow crawls to a halt and liquids start to accumulate in the flow line. This poses a significant risk to operations, effectively marking the end of field life.

Without gas compression, operators will shut down a well after extracting approximately 40% of the reserve, meaning that simply put 60% remains untouched in the well. Adding a compression station on the seabed helps augment the well's pressure and send the remaining gas onwards through to the host.

The benefits of subsea compression

The technology of topside compression has been in use since the '90s. However, a platform-based compressor demands a lot of energy. The gas must be pulled up first, then compressed, and sent back down through the pipes heading to shore. Placing the compressor on the seabed at essentially the same elevation as the wells minimizes the energy needed for compression power. In fact, compared to conventional compression technology, subsea compression can reduce the compression power by 90% and extensively increase the recovery from aging gas fields with minimum carbon footprint.

In short, subsea compression increases the amount of gas that is possible to extract from a well. It can at the same time increase the



maximum production rate (plateau rate) beyond what would be feasible for a pressure sustained reservoir.

Support energy transition efforts

Where does our energy come from? In 2019, coal delivered 162.4 exajoules of energy versus 140.8 from natural gas extraction. However, the process of burning coal to produce energy releases nearly twice as many greenhouse gases into the atmosphere as natural gas power plants do.

Every step towards lower emissions counts. And every effort to decrease our reliance on coal-based energy brings us closer to a net-zero goal, where unavoidable emissions are effectively compensated.

Relying on fossil fuel, be it coal or natural gas, isn't a sustainable option in the longer term. But in the mid-term, burning gas instead of coal to produce our energy contributes to lowering emissions. And

it buys us some time to fulfill the much-needed transition towards sustainable energy sources.

Gas reserves are still plentiful on the planet. If owners and operators focus on prolonging the lifetime of already developed wells, they are not only likely to increase profitability by minimizing investments while maintaining revenues. They also deliver an energy source that is less damaging to the environment.

A blend of monetary, political, and environmental benefits

Some nations like China, Malaysia, India, and Bangladesh, are heavily dependent on coal. Coal is the only large fuel source that is available domestically. Being energetically self-sufficient, or at least largely self-reliant, provides a major geopolitical advantage. But unlike coal or oil, natural gas and its sales product liquefied natural gas (LNG) can be purchased on the spot market. It grants nations that do not own large natural gas

reserves the flexibility to maintain economic and political independence. For all of these reasons, coal-dependent nations should consider retrofitting their coal-fired power plants to employ LNG as an energy source.

Subsea gas compression is an energy-efficient solution. It generates fewer emissions, owing to the large reduction in required compression power compared to traditional topside solutions, and increases production from existing and new fields. Its environmental footprint is significantly lower than the one of topside or onshore solutions.

Its economic and environmental benefits are clear. But is the technology mature enough? How far can owners and operators today rely on it?

Why digitalization matters

Why is digitalization so crucial to subsea compression technologies? Take the automotive industry example: digitalization helps cut down

lead times and speeds up engineering processes. And, although simulation is widely used to accelerate the product development cycles, automotive manufacturers can always fully test their prototypes before introducing new technology to market.

But subsea process system manufacturers typically don't have that luxury. Think about the Jansz-lo field: it features three 12-megawatt compressors operating in parallel. It would be a daunting task to test for design purposes a system at full scale that weighs more than 4000 tons and feeds an LNG plant producing 16 million tons per year. The first opportunity to physically test the full system will occur on the seabed at a depth of 1,300 meters. But, down there, there is no room for error. Failure is simply not an option. All systems need to be verified beforehand – but how?

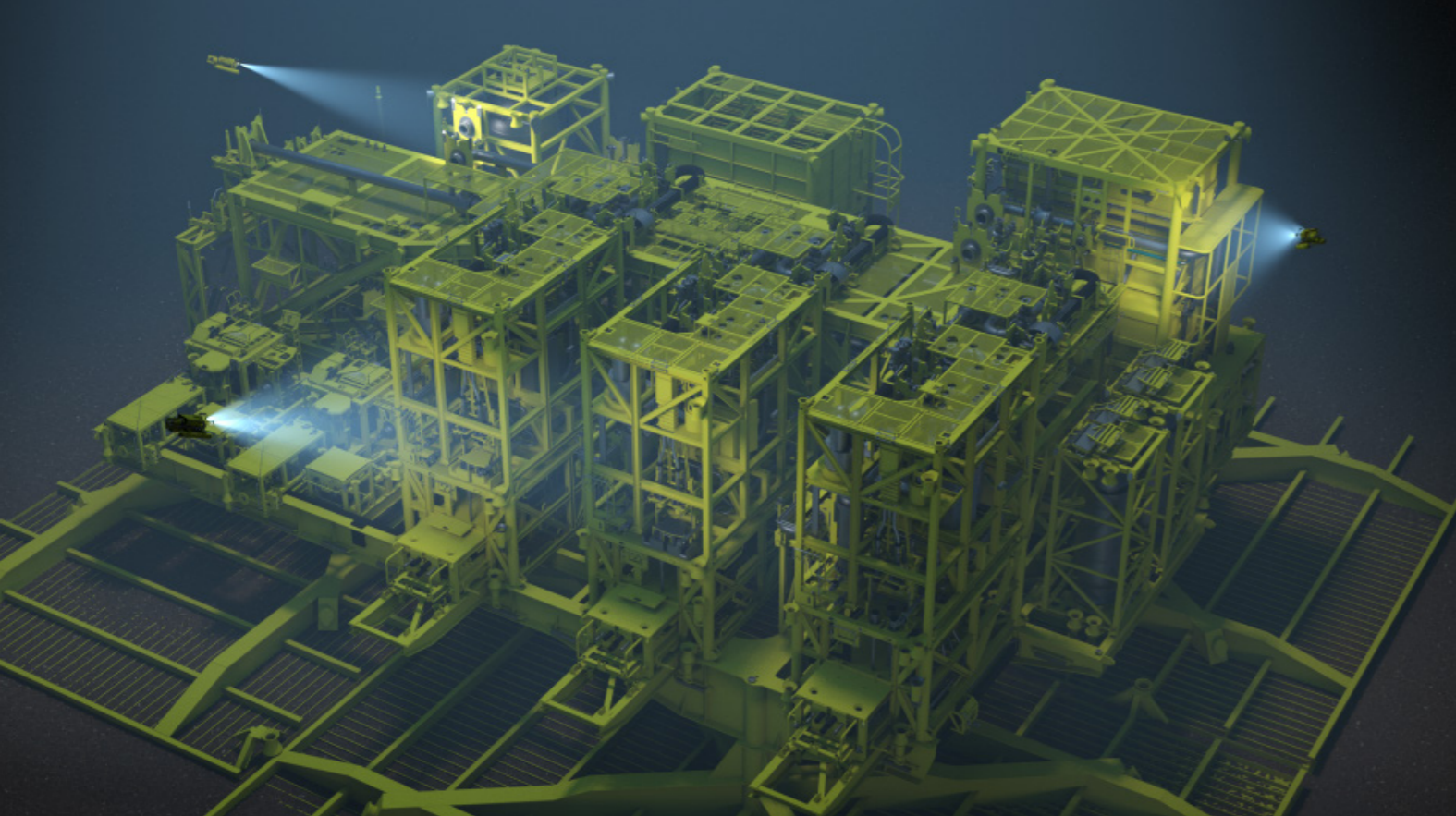

Image provided by Aker Solutions

The Jansz-10 field installation

The world-first subsea compression system was installed off the coast of mid-Norway on the Åsgard field. It has been delivered by Aker Solutions and its partners and is operated by Equinor. Since September 2015, the system operated with a regularity over 99.9%, resulting in an added production value of 220 billion Norwegian Kroner (NOK) with a total investment of 19 billion NOK. The Åsgard Subsea Compression System (SCSt) example constitutes a solid proof that subsea compression is a robust, well-qualified technology ready for worldwide implementation.

The Jansz subsea compression system is based on the technology qualified for and field-proven on Åsgard. The Jansz system, however, presents its own technological and operational challenges. The Jansz SCSt Inlet Scrubber is an engineering feat undertaken to reduce the overall system size whilst handling immense gas rates. It is by far the world's largest high-pressure scrubber, with three compressors running through it, operating at a suction pressure in excess of 100 bar. And it is designed to operate autonomously, in a maintenance free environment, at 1400m water

depth for 50 years. The single scrubber configuration significantly reduces the overall size of the system, compared to the standard configuration of a single inlet scrubber per compressor as seen on Åsgard. Another noteworthy engineering achievement is the SCSt Discharge Cooler which is certainly the world's most effective passive subsea cooler. It has a rated heat dissipation in excess of 50-megawatt, operating at an efficiency approaching the one of an onshore process cooler.

Barras explains: "It is both exciting and challenging to know that in Western Australia, the conditions are quite different to what we experienced previously. So far, we've successfully completed three subsea compression projects, all of them in Norway. Norway has relatively shallow waters. In Western Australia, the waters are deeper. And the equipment must be designed to withstand enormous pressures, which is another challenge."

Despite the difficulties, all the complex equipment parts will need to operate flawlessly for the entire lifetime of the field and fulfill the requirements. How can engineering teams ensure the flawless operation of the systems?

The benefits of integrated, trustworthy digital tools

Enters digitalization. Engineers will need to test all the equipment numerically before it goes down to the seabed. The Aker Solutions teams have spent multiple years testing and validating the numerical tools, with scale-testing methods, medium-pressure and high-pressure applications to validate the simulation processes. The Simcenter™ STAR-CCM+™ software is one of the numerical tools that underwent a thorough validation process. Simcenter STAR-CCM+ is part of Siemens Xcelerator™ portfolio, the comprehensive and integrated portfolio of software and services from Siemens Digital Industries Software.

Alfredsson explains: "The engineering of the inlet scrubber demonstrates the effectiveness of computational fluid dynamics (CFD) simulation. The hybrid multiphase model in Simcenter STAR-CCM+ is tailored to our applications, fluids, and pressures to ensure that it replicates real behaviors. We validated the model against test data obtained from separate test loops around the planet. Therefore, we can use our numerical test benches to qualify the technology. So, the first time we start up the station, we are already certain of its performance".

The Aker Solutions engineers used this approach previously to test the Åsgard subsea compression system. The numerical validation confirmed that the individual components were fully functional. Once in real conditions, the Åsgard field operations show a higher regularity, meaning that the operation uptime is higher than that of a field that doesn't rely on compression.

According to Alfredsson, "this is a true testament of a robust system enabled by the successful integration of digital tools and real-life components."

Lower emissions

Do you know which phase of the oil and gas production process is the most damaging to the environment? In fact, most CO₂ emissions result from the operating systems' power consumption. A digital twin helps control, monitor, and ultimately optimize production. In that way, it contributes to optimizing or reducing the energy consumption of machinery in every step of the production process: extraction, separation, compression, etc. Ultimately, it minimizes the overall CO₂ emissions.

Therefore, the digital twin technology not only helps optimize any process, whether it relies on topside or subsea compression, it also contributes to reducing harmful emissions.



Image provided by Aker Solutions

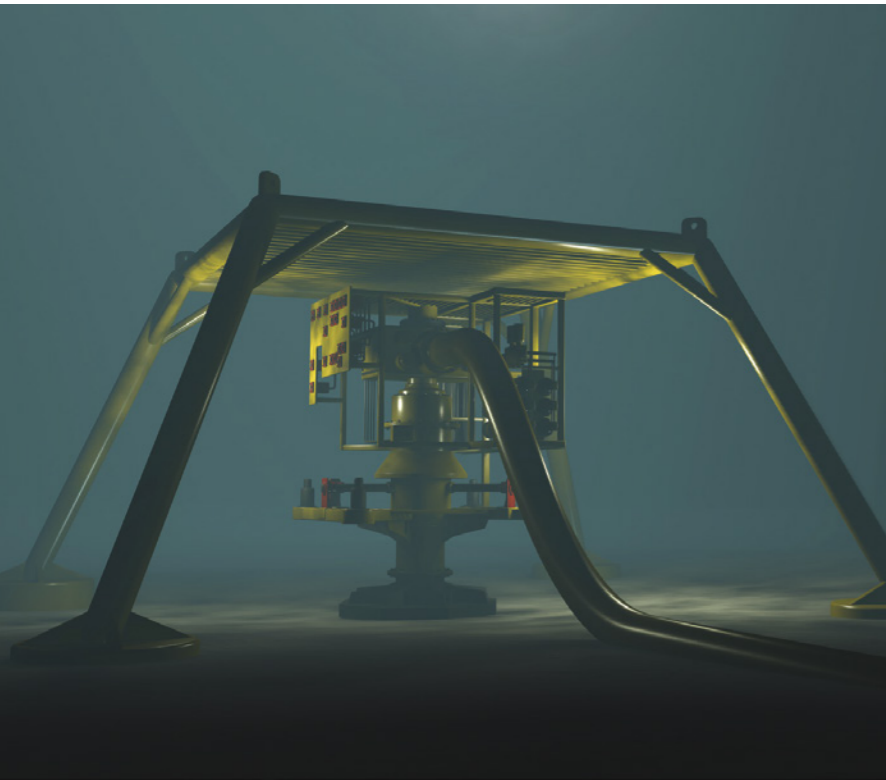

operation: operators can take preventive or corrective actions without unexpectedly shutting systems down. The digital twin technology and intelligent condition monitoring capabilities are part of the future-proof subsea compression system.

Digital twins partially rely on reduced-order models. Indeed, the condition monitoring system for the subsea compression station has strong computational power. However, it is impossible to have extremely heavy models run in the system. The Aker Solutions engineers characterize the equipment to develop a reduced order of the digital twin that can run online together with the asset.

A digital twin also helps operators visualize the operation of a specific part in terms of a performance map. The current operation mode appears as a small floating ping's ball above the response surface. If the ball moves closer to the response surface, the operator immediately understands that the system might enter a mode outside its design specifications. Operators don't need to be application experts, as they can assess risks at a glance.

Deploying the technology worldwide

Why is the successful deployment of the Jansz-Io subsea compression system a milestone for the oil and gas industry?

Barras explains: "When completed, we can reuse the qualification done for the Australian project to cover approximately 80 to 90% of the oil and gas field application worldwide. Once the subsea compression system is in operation, it becomes a proof of concept and opens the door to setting up future subsea compression projects. And this is quite exciting!"

A technology for smaller and marginal fields

Indeed, the subsea compression technology supports the gas production of large fields. However, it is possible to scale it down and apply it to the production process of smaller fields. The core technology, however, remains similar. The

well stream compression is a compact and simplified solution with a wider range of applications. For marginal fields, the added energy from subsea compression overcomes the resistance of long-distance pipelines. Therefore, the technology is particularly attractive in the field development phase as it allows engineers to consider more options.

Supporting countries with no infrastructures

Aker Solutions expects to deploy subsea compression systems in countries with no gas production infrastructure. For instance, some countries in Western Africa or Latin America may have gas resources that are currently not valued. In some cases, there exists an infrastructure to produce oil, but the remaining gas is just flared out. The compression technology can help maximize the output from existing small wells and

open up more possibilities for exploiting resources.

Subsea compression makes it easier to process gas and transport it to shore to convert it into electricity. Countries with a poor electrical network could greatly benefit from the technology and improve their electrical grid while minimizing emissions.

A future-proof technology

"Our world-leading technology improves field recoverability while offering carbon emission efficiencies compared to traditional compression alternatives," said Kjetel Digre, chief executive officer of Aker Solutions. Combined with renewable energy sources, the subsea gas compression technology effectively supports the transition to more sustainable energy production processes.

Image provided by Aker Solutions

Barras adds: "Depending on the type of application, the energy-saving range from 10 to 70%. This fulfills one of the objectives of Aker Solutions. The complete numerical models of the production systems, our so-called digital twins, support operators in optimizing their production process and reducing the energy consumption of the different systems."

Monitor conditions and minimize maintenance

Aker Solutions uses digital twin technologies based on the Simcenter portfolio as an integrated condition monitoring system for the scrubber and the inherent cooler technology. The digital twin informs how the system will or should operate during a specific timeframe depending on the conditions. It tells whether the system remains inside or falls outside its normal mode of operation. In which case, the operator learns that a potentially damaging event has occurred. This event may not cause an issue yet but could grow into one and jeopardize operations. The digital twin technology helps predict future modes of

Subsea compression technologies

There are two technologies currently available for subsea compression.

Conventional Subsea Compression Systems

The conventional subsea compression system includes a subsea separator, a compressor and pump units. The conventional technology involves commingling several wells. Smaller fields may have a single well, but large fields have multiple ones. The technology commingles the output of several wells into one line and sends all constituents into one compression train. An inlet scrubber separates the gas and liquid in the compression train. It sends the liquid through a pump and the gas through a compressor. Eventually, all elements are sent onwards through the pipeline. This technology is the one that is currently installed to operate the Åsgard field. The conventional technology

is mostly used for high-capacity applications, as it complies with the most stringent requirements and can tolerate the most challenging upset conditions.

Well Stream Compression Systems

The well stream compression technology is similar but excludes the separation process and dedicated pump. The technology lets an extensive amount of liquids flow from the well stream through the compressor. It doesn't separate liquids but sends the well stream output through the 12-megawatt compressor and immediately downstream. This technology is particularly suited for smaller and marginal fields since it avoids the capital investments affiliated with scrubbers.



BRING YOUR KIDS TO WORK EPISODE 1

The executable digital twin

By Stephen Ferguson

We recently invited some of our key staff to bring their kids into the office and to try to explain in a child's terms what they do for work. The results were entertaining, funny, and quite informative. In the first episode, we invited Siemens' executable digital twin expert Ian McGann to talk to his son Colin to talk about how Simcenter is helping to engineer a more sustainable world by designing better wind turbines. As usual, like most conversations, with Ian, [he didn't take long](#)

[to twist the conversation round to the executable digital twin:](#)

The key insight from Colin here is that although Siemens can help to design the individual parts of the wind turbine - more efficient blades, quieter turbines, and more robust gearboxes. All of this is important during the design of the wind turbine, but what happens when the turbine is out in the field, or more likely out at sea?

This highlights a key difference in how most of us in the simulation and test game define ourselves (mainly "helping to design things to make the world a better place") and how members of the public define engineers ("people that fix broken machines").

The executable digital twin is a way of reconciling this. It's a way of extending the usefulness of the simulation models that we create into the operational life of the products we design. It's a way of extending measurement and test throughout the lifetime of a product. More than that it's a way of combining simulation and test inside a living, breathing model that learns and evolves from the conditions that it experiences in the field (or more likely in the middle of the ocean).

Once Colin had left the building, I sat down with his dad, for a less child-friendly chat about the executable digital twin as applied to wind turbines.

1. The xDT is not just another "black box"!

"For a land-based wind turbine, I can easily walk up to it, plug a device in, and say 'give me your updated status, everything is easily accessible,'" says McGann. "Out in the middle of the ocean, nothing is easily accessible, it's much more expensive in terms of time and resources. It can also be dangerous in the wrong weather conditions. This means I don't want to go and do regular maintenance every six months if I don't absolutely need to. So, I really need the wind turbine to tell me ahead of time when it's going to break."

Traditionally this problem was (and still is) tackled by collecting lots of operational data from existing

Bring your kids to work

Ian & Colin McGann



wind turbines to construct a statistical model to predict when some essential component of an individual turbine might fail.

"These algorithm-based approaches are too reactive for something like a wind turbine for which I don't necessarily have a lot of data and for which failure modes might be particular to a specific installation or use case. We need a more industrialised approach."

According to McGann, that is where the executable digital twin (or xDT for short) comes in.

2. The xDT is physics-based!

"During the development process, we rely on embedding physical sensors into a product – for example, a wind turbine blade – so that we can validate our simulation models and gain confidence that they are providing sensible predictions," explains McGann. "There might be hundreds of sensors embedded into a test blade."

"Ideally, we'd like to have our production turbine blade providing that much data, but no one can afford to build hundreds of sensors into every blade," says McGann. "But the good news is that with the xDT, we don't need to because we can replace them all with two or three sensors and a physics-based model that can predict response data at any number of 'virtual' sensor locations".

What is happening here is that the executable twin is running real-time simulations in the background, which allows it to reconstruct data across the whole model that corresponds with the known data measured at the limited number of actual sensors. This is not "extrapolation" but physics-based prediction.

"You have to have known inputs, so the virtual model needs to know where the sensors on the real model are located, but the output can be anywhere on the whole model," he explains McGann. "You can even put "virtual sensors" in places that would be impossible on the real blade."

3. The xDT is adaptable!

Of course, we are not just talking about training a prediction model in the lab and then deploying it in the real world. To be useful, the executable digital twin must adapt and learn from its environment. According to McGann, that's not a problem; it's one of its strengths.

"We can augment the xDT with new data using Kalman filters, where we make it smart," says McGann. "So, the xDT updates itself. What happens is you get data coming in, and the model says, 'Oh, this is new data, I don't recognise it!' so it correlates the known inputs with the known outputs, and the model automatically adapts. It

says, 'I'm going to match whatever you're telling me is the input.' And it gives you really nice results."

"The question is do I need a different digital twin for each turbine I develop?" asks McGann. "We're increasingly finding that the xDT is so adaptable you can often deploy the same xDT on a different wind turbine, and the model just updates itself. We're even building a small demo version using the same xDT so potential customers can play with it themselves."

4. The xDT is available NOW!

There has been a lot of talk about digital twins in the last few years, but there are relatively few real-life examples of them. I ask Ian if the xDT is available today, or is it just another digital pipedream?

"I think the difference is if somebody said to me, 'I want to create that flexible Digital Twin that you're talking about,' 10 years ago, we could have done it. And it would've been a great services project, and it would've been a couple of million dollars, and it would've been very fixed to that design," explains McGann.

"So, what we've done now is that we've created the software behind it to make it easy to create, easy to validate," and then the deployment and the management of those Digital Twins is now in place. And that wasn't there before. So, customers would've said, 'I can't create this myself. I need an expert to help me. It's literally a button you press!'"

5. The xDT is secure and scalable!

So, having determined that xDTs are ready to be deployed in the real world, the next question is one of scalability and security. How do we cope with all the data transfer and processing if we have these arrays of wind turbines out at sea, each with a digital twin on board? How do we make sure that the data is secure?

"Well, why would you transfer the data?" he asks pointedly. "Why not just transfer the updated Digital Twin and the inputs? And that Digital Twin can be compressed, and it can be made so that it's not hackable. It's IP protected. So, the customer who creates that Digital Twin is creating their IP into that Digital Twin. And rather than transferring data that might not be secure, I now have a secured validated model, and I can just move the model around and then recreate all my data."





GEEK HUB

Optimization and robust pizza camera design

By Wendy Luiten

In 1965 Intel's George Moore predicted that available computing power would effectively double every year. "Moore's Law" has held up empirically for more than 55 years. That increase in computing power has allowed engineering simulation to become an essential part of the product design process. But it is much less known that the advances in computer power and computational tool development can be used to guide a design, and to develop the best possible design solution in a structured way, using data driven decisions based on the results of multiple computer simulations.

A news item inspired the following fairy tale on the thermal design of a Pizza Camera, illustrating the possibilities. The case itself is fictional, but the content is based on the authors practice as a thermal expert and a certified Master Black Belt in Innovation Design for Six Sigma. (DfSS).

Requirement elicitation: The story starts with the business idea for a pizza surveillance camera for

the pizza food industry. Stakeholders are approached for requirements: The pizza cook says it needs to work in a hot kitchen and show if the toppings are put on correctly. The food safety specialist wants it to measure temperatures accurately, be easy to clean, and be reliable. And the device installers want it to be small and compatible with the accessory line. In the end, the requirements state a small size of about 5 x 5 x 5 cm, in a closed box, containing a color and IR image sensor and video processor, with a max ambient of 50°C and a wish for 65°C, and high reliability and accuracy – starting from 95%.

First concept

The first concept features a sealed enclosure of 50 x 50 x 60 mm, containing 3 critical components with a max device temperature of 80°C. Total heat dissipation is 6.6 W. A CFD simulation on this first concept shows that this design is not feasible thermally.

Digital design optimization

After a fruitful brainstorm, the development team comes up with alternatives for 5 design decisions. But how to find out what alternatives are best? Design of Experiments (DoE) is a technique that compares the results of groups of experiments to separate effects. Crucially, multiple inputs are changed at the same time, as this enables to find interactions, cases where design choices strengthen each other. In this case, a 16 run partial factorial DOE design was run with 2 options for

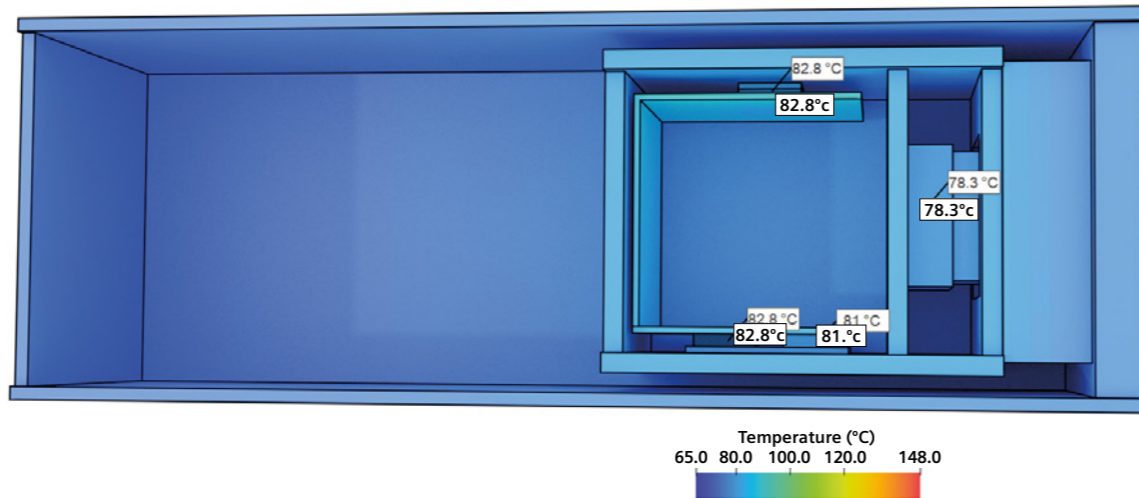

each of the 5 decisions. Using the parametric capabilities of the computational tool, this is as easy as setting up the DOE matrix, let this solve automatically, process the results, choose the best design and verify with a computer simulation incorporating all design choices.

The best concept is already 64°C better ... but it is still too hot. The team decides to use a smart temperature control to derate the device at high ambient. But how does the heat dissipation relate to the critical temperatures? A second DoE scenario is used, running variations with different component dissipations, different ambient temperatures and whether there is an external housing yes or no. Analysis yields the relation between the critical component temperature, ambient and heat dissipation. Assuming a duty cycle type control with 100% performance corresponding to the nominal 6.6 W heat dissipation, a derating of 10% heat would correspond to 90% heat dissipation and 90% performance. It turns out that for ambient temperatures below 50°C no derating is necessary. Without external housing, derating starts at 51°C and at 65°C performance (duty cycle) is at 37%. With housing, derating starts at 59°C and performance at 65°C ambient is at 73% ambient.

Robust design

Manufacturing spread and differences in application software cause a +/- 25% uncertainty in the heat dissipation. This can be lowered to +/- 10% when a low-power mode is activated when derating. In addition, the temperature sensor has a measurement error of +/- 6°C before and 0.6°C after calibration. The variations are assumed to have a normal (gaussian) distribution with a range of +/- 3 standard deviations. Recalculating the performance many times with slightly different heat dissipations and temperature measurement errors results in the expected distribution of the performance over many cameras. This procedure is called Monte Carlo Simulation. In case of the pizza camera, we assume that the variations in heat and sensor are normally distributed with a range of +/- 3 standard deviations. The new calculations show that the performance becomes a wide band instead of a curve. When the variability in heat dissipation and sensor error is reduced, the bands become narrower, and the behavior is more predictable.

To gain insight into how this unpredictability will affect the customer experience, we look at the distribution at a fixed temperature. At 65°C ambient, the camera with external housing has an

Inputs according to DOE scenario	1	2	3	4	5	6	7	8	9	10	11	12	13	14	15	16	17
System Ambient	65°C	20°C	20°C	20°C	20°C	20°C	20°C	20°C	20°C	20°C	20°C	20°C	20°C	20°C	20°C	20°C	20°C
Temperature Thermal	11W	0.01W	0.01W	0.01W	0.01W	0.01W	0.01W	0.01W	0.01W	0.01W	0.01W	0.01W	0.01W	0.01W	0.01W	0.01W	0.01W
Load Thermal	1W	0.01W	0.01W	0.01W	0.01W	0.01W	0.01W	0.01W	0.01W	0.01W	0.01W	0.01W	0.01W	0.01W	0.01W	0.01W	0.01W
Component 1 Thermal	1W	0.01W	0.01W	0.01W	0.01W	0.01W	0.01W	0.01W	0.01W	0.01W	0.01W	0.01W	0.01W	0.01W	0.01W	0.01W	0.01W
Component 2 Thermal	1W	0.01W	0.01W	0.01W	0.01W	0.01W	0.01W	0.01W	0.01W	0.01W	0.01W	0.01W	0.01W	0.01W	0.01W	0.01W	0.01W
Component 3 Thermal	1W	0.01W	0.01W	0.01W	0.01W	0.01W	0.01W	0.01W	0.01W	0.01W	0.01W	0.01W	0.01W	0.01W	0.01W	0.01W	0.01W
Component 4 Thermal	1W	0.01W	0.01W	0.01W	0.01W	0.01W	0.01W	0.01W	0.01W	0.01W	0.01W	0.01W	0.01W	0.01W	0.01W	0.01W	0.01W
Component 5 Thermal	1W	0.01W	0.01W	0.01W	0.01W	0.01W	0.01W	0.01W	0.01W	0.01W	0.01W	0.01W	0.01W	0.01W	0.01W	0.01W	0.01W
External Housing	No	No	No	No	No	No	No	No	No	No	No	No	No	No	No	No	No
Temperature Sensor Error	6°C	0.6°C	0.6°C	0.6°C	0.6°C	0.6°C	0.6°C	0.6°C	0.6°C	0.6°C	0.6°C	0.6°C	0.6°C	0.6°C	0.6°C	0.6°C	0.6°C

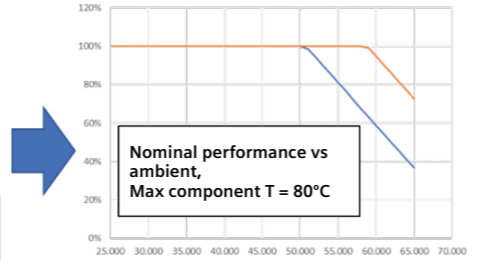

expected performance of 73%. Let's assume that a customer is satisfied if the actual performance is between 68% and 78%. A second Monte Carlo simulation demonstrates that without mitigation, only 36% of pizza cameras will meet expectations. About 1/3rd derates too much resulting in unnecessary slow applications and blocky images and about 1/3rd derates too little, resulting in pictures with image noise. With reduced variability 95% meets the expected performance.

In conclusion

The pizza camera story is a purely fictional example, based on news items on a pizza camera and combining thermal design and statistical

cases from the author's practice. It serves the purpose of illustrating the power of digital design, using computer simulations not only as an after-the-fact design validation, but frontloading to enable data driven decisions during the design process. In this example, a total of 8 key decisions were made based on 2 DoEs with 16 runs each and 2 Monte Carlo simulations with 5000 runs, a modest effort in the digital domain but an unthinkable effort in hardware. In the end, the design is not only 62°C cooler than the original, but there is also evidence that about 95% of the pizza cameras will perform as expected. The development team can enter the stage of hardware validation with confidence.

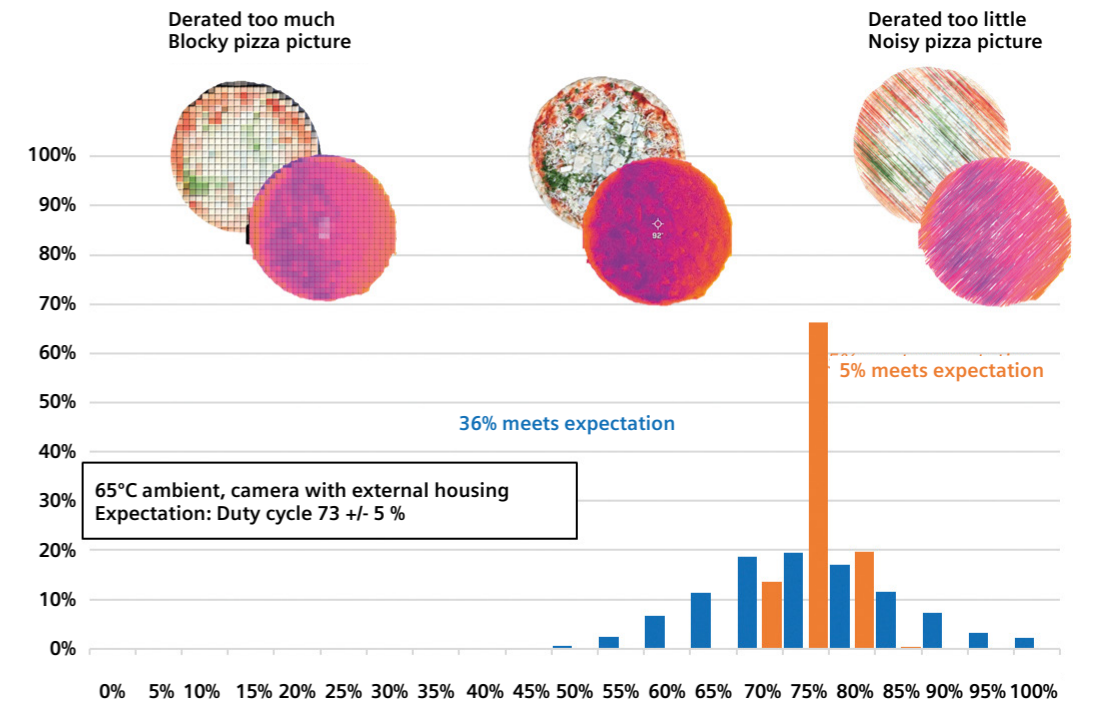
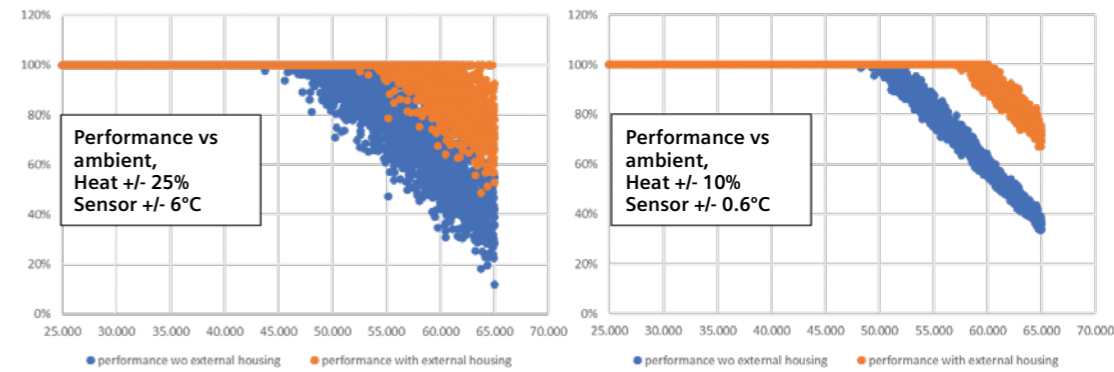



BROWNIAN MOTION

The random musings of a Fluid Dynamicist

Two years of solitude...three days of redemption

Brownian Motion (BM) found themselves back at live events this week, more specifically Realize LIVE in Berlin. As a strong proponent of a sustainable lifestyle, travelling by air doesn't sit comfortably and of course after two years of on-line events, the question is: are live events necessary? Part of the guilt / carbon footprint was assuaged by using public transport and electric taxis for either end of the air leg, but the question does remain, was it really necessary?

Navigating through an event as large as Realize LIVE after two years of isolation in BM's spare room is not without its hazards. Having had unfettered access to caffeine-based drinks for that time (fair trade, organic and only boiling enough water each time) would I cope with just two coffee breaks each day? And would I be able to hold a face-to-face conversation at midday, let alone 8 am or possibly worse still, 8pm?

Day one saw the usual big room, opening keynotes, so 750+ engineers all together reflecting on the gargantuan task our profession has ahead of us: *and could one still survive without an afternoon nap?* It was almost enough to have BM scuttling back the sanctity of room 101. But as the event unfolded, the task was starting to feel more manageable.

We focused on the Simcenter sessions in this event, the buffet stations, and social events. Much can be learned at the buffet station, the plate-piler, the nibbler, the return-many-times and the meetings-all-the-way-through-lunch-so-miss-food-altogether. The buffet stations also attract the students, and this is where Brownian Motion really felt a sense of hope for saving the human race. Several student teams were at Realize LIVE showcasing their developments both on the expo

floor and in breakout sessions. And almost every session was focused on working towards greater sustainability from improving EV ranges, to optimizing the use of hydrogen, reducing prototyping, automation removing humans from difficult working conditions, and discovering life on Mars.

And these events are not just about the presented content but the symbiotic content that just being with like-minded, change-driven engineers brings. There was much also to be learned from the artistic tendencies in the audience, in a city whose life blood lives and breathes creativity Brownian Motion also had a dabble with graffiti.

By day three the atmosphere really felt different, there was an ease in meeting and discussing issues with other delegates. The buffet stations held less interest as the old friends reacquainted and new colleagues were discovered.

Brownian Motion was left wondering how it had really been two years of spare bedroom solitude and given all the possible advances in technology if maybe, just maybe meeting face-to-face again doesn't need to be environmental suicide.

// Much can be learned at the buffet station, the plate-piler, the nibbler, the return-many-times and the meetings-all-the-way-through-lunch-so-missfood-altogether"