



Protect your tomorrow with
**Sinorix™ high-pressure
water mist**

[siemens.com/water-mist-fire-suppression](https://www.siemens.com/water-mist-fire-suppression)

SIEMENS

Sinorix high-pressure water mist fire suppression for buildings, industrial facilities and tunnel infrastructure

Siemens is a global supplier of comprehensive fire safety systems, featuring Sinorix fire suppression solutions.

With numerous installations worldwide across buildings, industrial applications, and transportation sectors, we offer our customers an unparalleled competitive edge through uncompromising safety, innovative technology, and proven reliability.

Sinorix systems are designed to suppress and prevent fire hazards with maximum efficiency, protecting lives, assets, and business continuity.

Shaping a safer tomorrow – innovative fire safety solutions for a sustainable future

In today's rapidly evolving world, sustainable and efficient fire protection solutions are essential for addressing modern challenges. Siemens meets them with a comprehensive portfolio of advanced fire suppression technologies, highlighted by the **Sinorix high-pressure water mist system**.

This innovative system uses high-pressure water mist to swiftly and effectively suppress fires, minimizing damage and offering optimum safety for people and property.

As environmental awareness grows, our fire suppression solutions align with Siemens' sustainability strategy – maximizing safety while minimizing resource use to support environmentally responsible technologies.

A partnership with Siemens means transforming your safety infrastructure with reliable and cutting-edge fire protection technology to enable a safer and more sustainable future.



Advanced water-based fire suppression technology for optimal safety

High-pressure water mist is a technological innovation that improves on traditional sprinklers by turning water into a fine mist for an enhanced fire suppression effect.

High-pressure water mist uses a mist of very small water droplets to control and suppress fires. It is specifically designed to attack fires from two sides - quickly extracting heat from the fire and shielding surrounding areas from radiant heat, while displacing oxygen locally to suppress the combustion process.

Additionally, water mist systems are effective in suppressing various types of fires, including Class A (combustible solids), Class B (flammable liquids), Class F (fires from cooking oil and fat) and fires involving electrical equipment.

When comparing high-pressure water mist systems to traditional water sprinklers, the advantages are as follows:

1. The combined cooling and oxygen displacement provides a cooling capacity up to 7 times greater than traditional sprinklers.
2. The water consumption is reduced by up to 80% compared to traditional sprinklers.

Three reasons to choose **Sinorix high-pressure water mist systems**



Sustainable protection for people and assets

High-pressure water mist enhances the occupants' safety by providing safer evacuation routes. The reduced use of water ensures the protection of valuable assets from collateral damage and costly replacements.



Minimized water usage and downtime

Compared to traditional sprinkler systems or other water-based systems, the Sinorix high-pressure water mist system requires significantly less water. This reduces the need for extensive cleanup after a fire incident and enables a faster return to normal.



Lower cost for maintenance

All key components of the Sinorix high-pressure water mist system, including multi-axial piston pumps and the piping network, nozzles, and section valves, are manufactured from corrosion-resistant stainless steel, ensuring high quality and a long service life. The pumps use water as a lubricant, making them virtually maintenance-free.

One technology to protect all building types in a city
One system to cover all fire safety applications in a building
One supplier to offer a complete fire protection solution

Fire poses risks to lives, assets, and the environment. Sinorix systems provide reliable protection across diverse settings – from museums and industrial sites to offices, universities, and data centers.

With space-saving design, low total cost of ownership, and flexible installation, Sinorix delivers efficient and effective fire suppression tailored to operational and economic needs.

Data centers

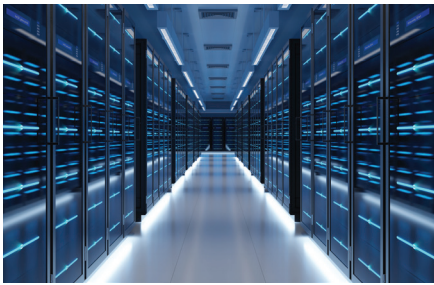

Healthcare facilities



Hotels

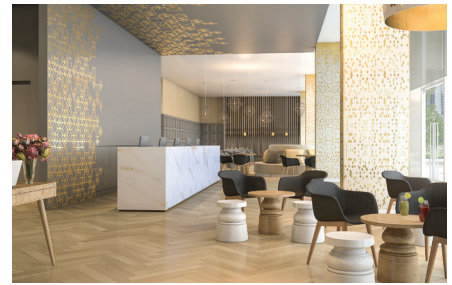

Educational facilities



Offices & High-rise



Heritage buildings



**Parking garages
with electric vehicles**



Road, metro and rail tunnel



Industrial facilities



The power behind Sinorix

The Sinorix high-pressure water mist system integrates advanced fire suppression technology through a comprehensive set of components, including a high-pressure modular pump unit, section valves, specialized nozzles, press fittings, and a stainless-steel piping network. The system operates with precise technical specifications, delivering water droplets ranging from 10 to 200 microns under working pressures of 60 to 100 bars through a clean water delivery system.

System design configurations

Sinorix system with closed nozzles

On standby, the system maintains a pipe pressure of approximately 12 bar. When the temperature exceeds, e.g., 57 °C, the heat-sensitive glass bulbs mounted in the nozzle heads melt. At this point, the high-pressure pump is automatically activated, and water is forced through nozzles at high pressure (60 or 100 bar, depending on nozzle type) to create a fine mist. Only nozzles with melted bulbs are activated. This means that only the heat-affected area will be actively sprayed. Also available for pre-action systems for critical and sensitive environments, like server rooms.

Sinorix system with open nozzles

On stand-by, the system has dry piping. This system will activate manually or when sensors have detected heat, smoke or a flame, depending on type and application. The nozzles are grouped in sections, and all the nozzles in the activated section will be released.

When activated, the system releases microdroplets through specialized nozzles, creating rapid evaporation upon contact with fire. This process expands the water volume up to 1,700 times, simultaneously providing cooling effects and oxygen displacement at the fire source. The systems' efficient operation ensures comprehensive fire protection while optimizing water usage.

Sinorix system in operation

During operation, the high-pressure pump draws water from the water supply and forces it through a non-return valve to a high-pressure manifold. From here, it is distributed to the relevant area(s) via the section valve.

Water supply

Water is supplied via either pump units or cylinder systems. This covers small systems of just a few nozzles, right up to systems with thousands of nozzles.

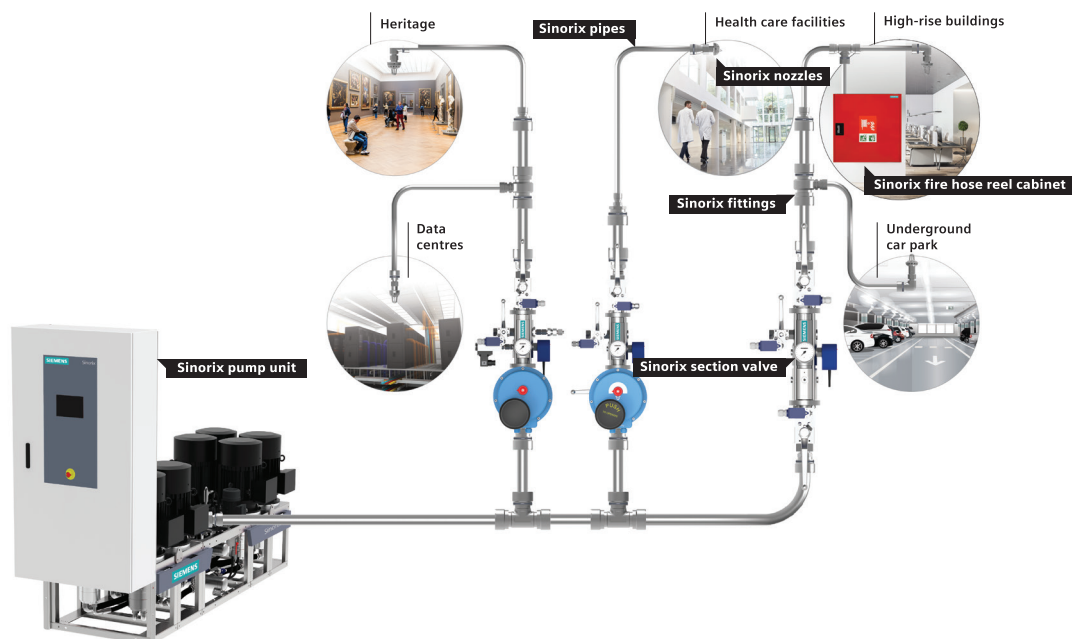

Key components of the Sinorix system

Sinorix pump units

To ensure reliable water mist system performance across diverse fire protection needs, Siemens offers two advanced pump types: electric and diesel-driven.

Electric-driven pump unit

A core part of the Sinorix system, this unit delivers high-pressure water consistently to the nozzle network. It features up to eight water-lubricated, multi-axial piston pumps powered by electric motors. Key components include high-pressure and pilot pumps, inlet/return/high-pressure manifolds, and a touchscreen control panel—all mounted on a compact skid frame.

The electric driven pump unit is available in different configurations.



Electric-driven pump unit

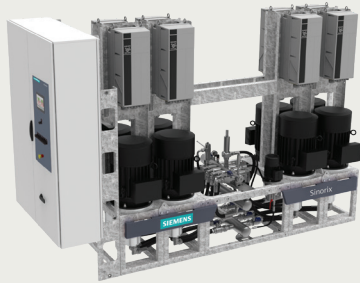

Electric-driven pump unit with frequency converters

Key benefits

- Robust construction: long-lasting, industrial-grade design
- Up to 140 bar operating pressure – perfect for high-rise buildings
- Increased water flow and minimal starting peak current for the pump unit with frequency converters

Diesel-driven pump unit

The diesel-driven pump unit ensures continuous operation even without grid power, making it ideal for critical environments that demand full autonomy. It supports three configurations: operating independently on diesel power, running electrically with automatic diesel backup in case of power failure or using two diesel units where each serves as a backup for the other to maximize reliability.

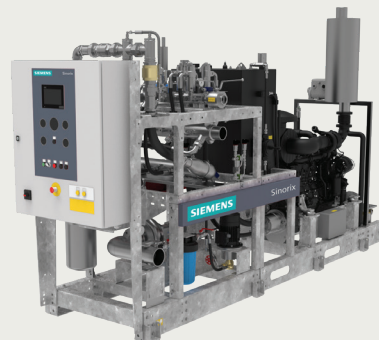

Key benefits

- Grid-independent operation: fully functional for up to 4 hours without reliance on external power
- Extended autonomy: monitoring and safety systems can remain operational for up to 5 days without external power
- Redundant startup logic: built-in double redundancy ensures reliable system startup and continuous fire protection readiness

Sinorix section valves

Essential components of the Sinorix high-pressure water mist system, section valves divide the system into independent fire protection zones, allowing selective activation and efficient water delivery in areas where the fire is detected.

Designed for versatility, the section valve supports several types of water mist systems:

- Wet
- Pre-action/dry
- Deluge

Key benefits

- High water flow capacity at minimal pressure drop
- Modular design allows flexible installation
- Stainless steel construction offers excellent corrosion resistance
- Easy to install, operate, and service, reducing maintenance time and cost

Features

The Sinorix section valve includes a compact, pre-assembled stainless steel arrangement, featuring:

- Inlet and outlet isolation valves
- Non-return valve (prevents backflow)
- Test valve for manual testing
- Pressure indicator for real-time pressure monitoring
- Flow switch to activate alarms upon water movement

Wet systems

The section valve for a wet pipe water mist system is a normally open section valve, i.e., the section valve is fully open in system stand-by operation mode, and the pipe system is filled with water from the pump unit and upstream to the automatic high-pressure water mist nozzles.

The system is activated when the thermal-sensitive glass bulb in the automatic nozzle bursts and the nozzle opens.

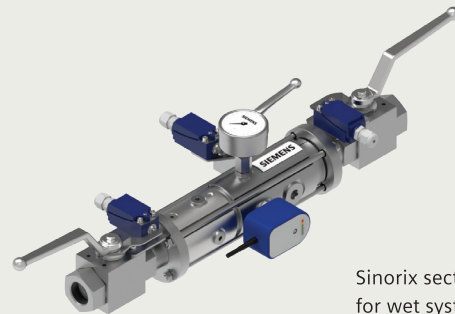

Sinorix section valve for wet system

Sinorix section valve for pre-action/dry system

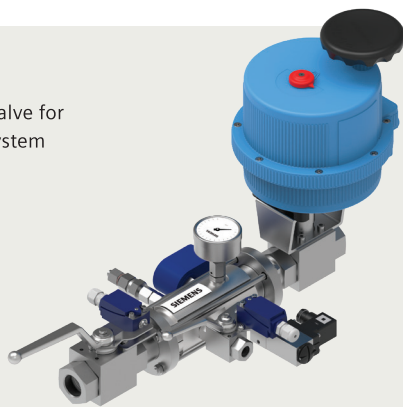

Pre-action/dry systems

A pre-action system is typically used where special precautions are required to avoid water mist being released unexpectedly in the protected rooms or areas, as a consequence of a false alarm, a leak or a broken nozzle head glass bulb. A pre-action system works in combination with an automatic very early warning fire detection system.

Deluge systems

A deluge system is employed in scenarios where multiple nozzles are released simultaneously, such as in local applications or total flooding systems. The deluge water mist system is activated when a fire in the affected area is detected by the automatic fire detection system, and a signal is set to open the deluge section valve and activate the high-pressure water mist pump unit.

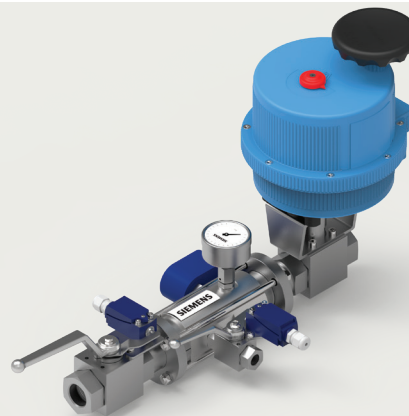

Sinorix section valve for deluge system

Sinorix nozzles

The Sinorix nozzles are key components of the Sinorix high-pressure water mist system, designed to deliver ultra-fine water mist for rapid fire control and suppression. Each nozzle is tailored to specific application needs, whether for occupied areas, machinery spaces, or sensitive environments.

We offer two types of nozzles for fire suppression systems. Automatic closed nozzles feature thermal glass bulbs and are available with either drilled holes or micro nozzles. Open nozzles, also available in both variants, are designed specifically for deluge systems in combination with a detection system.

Key benefits

- **Low water consumption:** minimises water damage
- **Wide spacing:** fewer nozzles needed per area
- **Aesthetic design:** blends seamlessly into modern or historical interiors
- **Proven performance:** effective in fire suppression and glass window cooling

Features

- **Droplet size:** 10–200 microns for maximum heat absorption and surface cooling
- **Material:** high-grade stainless steel for corrosion resistance and longevity



Sinorix open nozzle with micro nozzle



Sinorix open nozzle with drilled holes



Sinorix closed nozzle with micro nozzles



Sinorix closed nozzle with drilled holes

Colored nozzles

The Sinorix high-pressure water mist nozzles can be painted in any RAL color with standard gloss 10(mat) and up to gloss 90.

Benefits

- Aesthetics design to easily blend with the interior room design
- Freedom to choose any nozzle colour

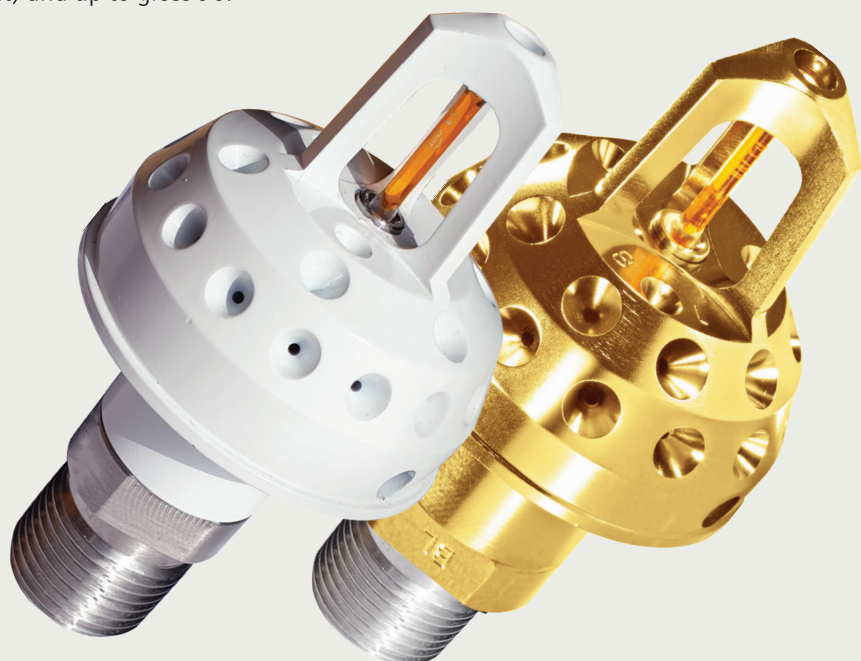

Nozzle cover plates and mounting kits

The cover plates are crafted from high-quality materials. They seamlessly bridge the gap between the nozzle and the ceiling, enhancing the overall aesthetics of the nozzle installation with a visually appealing finish.

All parts are mounted below the ceiling, thus saving installation and handling time.

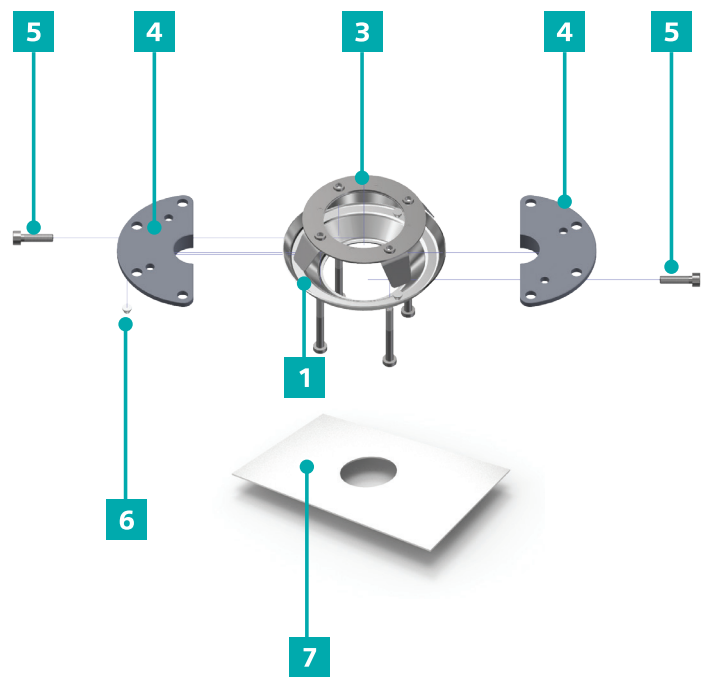
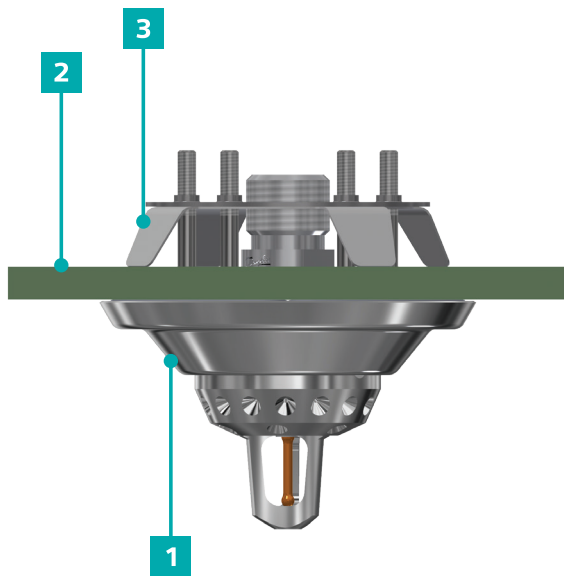

- 1 Cover plate
- 2 Ceiling
- 3 "Spider" (for drop hose installation in suspended ceiling)
- 4 Clamp disc
- 5 Bolts (clamp disc included)
- 6 Magnets (clamp disc included)
- 7 Support plate

Sinorix press fittings

Sinorix press fittings are essential components used to securely connect the pipe network with all the components and accessories within the Sinorix high-pressure water mist system. Designed for durability, they offer a reliable solution for modern fire protection installations.

Key benefits

- Corrosion-resistant contact surfaces for long-term reliability
- Wide range of diameter sizes to support flexible, custom installations
- Watertight sealing with proven press-fit technology
- Quick and easy installation - no welding or threading required
- Lightweight and compact design for space-saving installations

Features

- Body material: stainless steel 1.4404
- Press ring sets: carbon steel 1.1191, zinc-nickel plated
- Sealing material: FKM (Fluoroelastomer), where applicable
- Installation type: mechanical press connection (cold press)



Male stud coupling



Male stud coupling detach

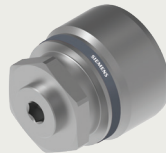

Male and female coupling plugged

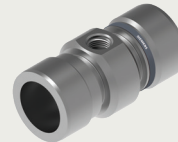

Distributor 1-fold female thread



Distributor 2-fold female thread



Straight male connector



Straight slider

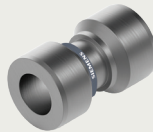

Straight



Straight coupling for nozzle

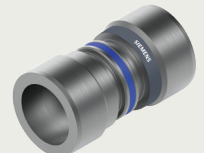

Straight pressure test



Elbow 90°

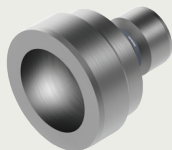

Straight reducer

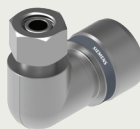

90° Coupling for nozzle



Pressure test plug



Flexible hose 90°



Tee



Tee with coupling for nozzle



Tee with coupling for nozzle reduced



Tee with male connector



Tee reducer



Tee reducer reducer

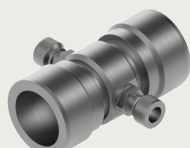

Cross reducer

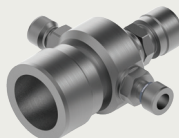

Cross reducer reducer

5 years
warranty for pipes
and fittings

Sinorix stainless steel pipes

The Sinorix pipes are tubes carrying water from the pump unit to the nozzles. Siemens offers pipes in a wide range of diameter sizes: 12 to 60.3 mm.

Key benefits

- High-quality stainless steel
- Small outer pipe diameter
- Successfully tested for high-pressure
- Lightweight
- Space-saving solution

Features

- High-class stainless steel (Material 1.4404)
- Welded stainless steel tubes acc. to EN 10217-7, W2Ab, TC2, Material 1.4404, Annealed
- Tolerances acc. to EN ISO 1127 D4/T3
- Length 5.800 – 0/+ 20 mm



Sinorix press tools and press pump

The Sinorix press tools and press pumps are designed for fast, safe, and accurate installation of Sinorix press fittings and pipes. With ergonomic design and smart hydraulic technology, they streamline the installation process across all pipe sizes.

For pipe diameter size 12–15 mm, we offer one integrated press tool and a handheld press pump. This combines power and control in one compact device. It is ideal for small-diameter installations.

For pipe diameter size 22–60.3 mm we offer two press tool versions 22–30 mm and 42.4–60.3 mm. Both press tool versions use the same smart hydraulic press pump, which maintains consistent pressing pressure and process accuracy.

Key benefits

- Fast & reliable pressing across multiple pipe sizes.
- Smart hydraulic pump ensures consistent quality
- Lightweight tools to facilitate the installation
- Poka-yoke design prevents operational errors by guiding correct usage



Press tool 12–15 mm with handheld pump



Hydraulic press pump



Press tool

Smart fire safety solutions with **CFD simulations**

One of our core strengths lies in Computation Fluid Dynamics (CFD) simulation – an invaluable tool in engineering and design. With CFD simulation, we simulate and analyse fluid flow, heat transfer, and related phenomena to provide invaluable insights into the performance and efficiency of our Sinorix system. By modelling complex scenarios, predicting outcomes, and identifying optimisation opportunities, we empower customers to make informed engineering decisions, minimize risks, and enhance the overall performance of your products or processes.

Benefit from Siemens CFD capabilities

Siemens provides the special CFD expertise and input required to do fire test simulations. This know-how, combined with our firefighting industry-related knowledge, has led to the development of tight collaboration with CFD experts worldwide. In addition, Siemens uses the software FDS (Fire Dynamics Simulator) required to do the simulation in-house with proven cases for healthcare, tunnel and car park sectors.

CFD fire simulation

in one of the widest tunnel projects in India

Siemens has developed CFD models that replicate the results of full-scale fire tests. These models are applied to the real tunnel in order to document the water mist system's ability to control and suppress a potential fire inside the tunnel. The CFD model can also be used to analyse if the ventilation capacity could be reduced and whether the safety of people, fire brigades, and the structure is still adequate.

It can be clearly seen that the temperatures in the evacuation zone were at tenable levels throughout the full-scale fire test, i.e., at least 10 minutes after the activation of the water mist. It can also be seen that the criterion for untenable conditions was not reached throughout the full-scale fire test. The CFD model validation replicated the trend from the full-scale fire test with 10–20% accuracy, so the model is considered a good, validated CFD model. For the tunnel project in India, the CFD simulation showed that the temperature in the evacuation zone can be kept well below untenable conditions thanks to the water mist system, as well as the tunnel being much larger than the one in which the full-scale fire test was conducted.

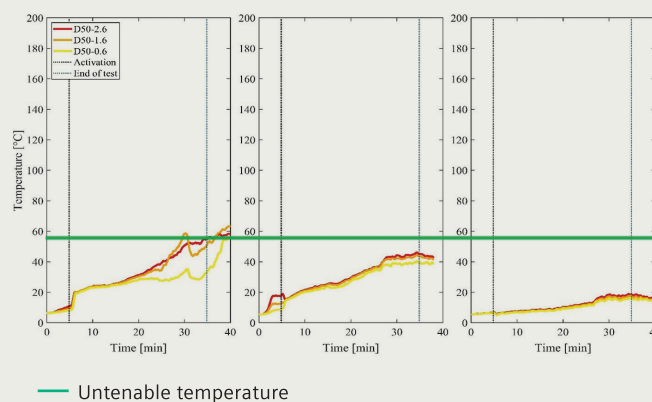

Temperatures at 50 m downstream (D50) from the centre of the mock-up fire at 0.6 m, 1.6 m, and 2.6 m above ground level.

Left graph: Full-scale fire test

Middle graph: CFD model validation

Right graph: CFD simulation for the tunnel project in India

Protect the value of your firefighting system with **original Sinorix spare parts**

By choosing Siemens as your spare parts provider, you are choosing the best possible care for your firefighting system. With Siemens, you benefit from direct access to original Siemens spare parts.

The spare parts we supply to you are the same as those we use in production and for service. You are thus assured of receiving parts that fit perfectly with your equipment and will not impair the safety or lifetime of your equipment.

Your fire safety system is one e-mail away from receiving top quality reliable spare parts.

Spare Parts: firesafety.spareparts@siemens.com

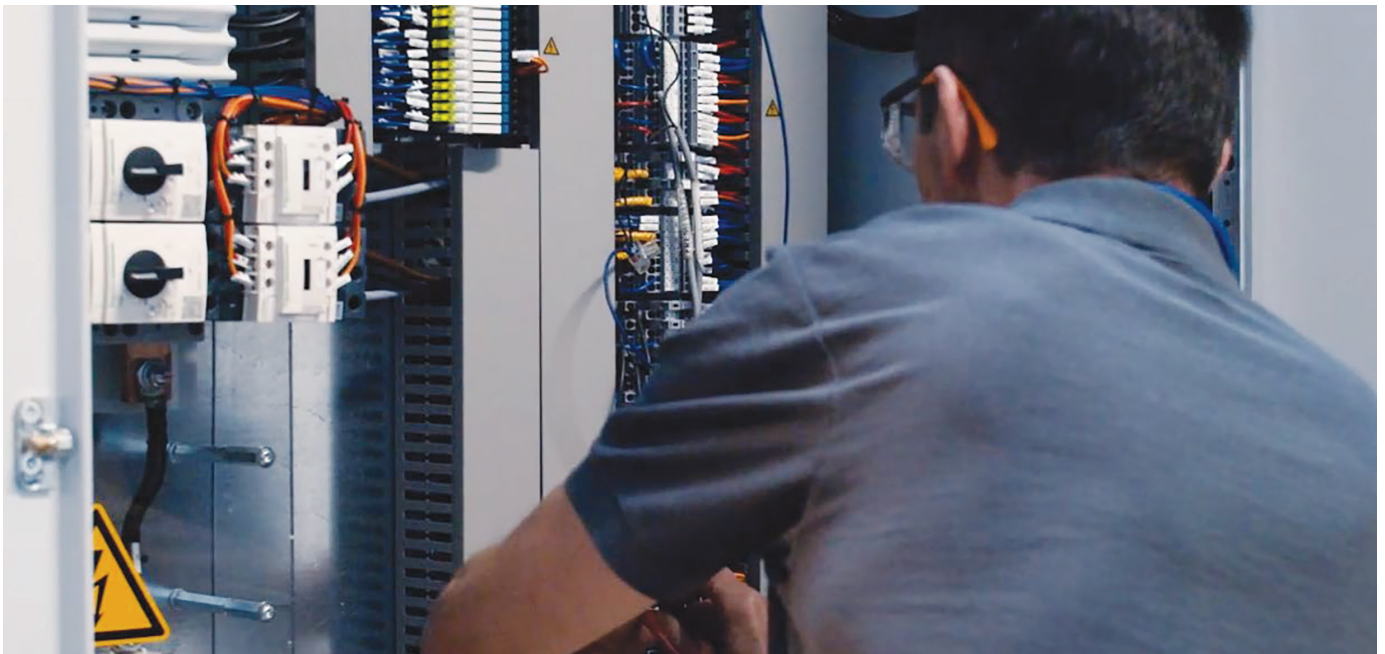

Tested and approved

Approvals are obtained through testing in accordance with specifications from applicable international standards for fire suppression systems, such as FM and VdS. Siemens manufactures VdS and FM approved products and is subject to regular audits, ensuring product quality and conformity to strict requirements.

Compliant with ISO standards

Quality, Environmental, and Health and Safety management systems at Siemens are compliant with corresponding ISO standards and are certified by DNV. Our ISO quality management system certification demonstrates our commitment to environmental stewardship, product quality, workplace safety, operational efficiency, and customer satisfaction through our products, systems, and services.

Training and development center

At Siemens' state-of-the-art Training and Development Centre in Odense, Denmark, we offer a wide range of training opportunities tailored to meet the needs of fire safety professionals, from newcomers to experienced engineers.

What we offer

Our training programs cover the full spectrum of Sinorix high-pressure water mist technology, including:

- Basic introduction to water mist fire suppression
- In-depth product knowledge of the Sinorix system
- Advanced system design and configuration workshops
- Fire tests & approval procedures
- Hands-on service engineering and installation training

Hand-on training

Participants gain valuable hands-on experience across key components of the system.

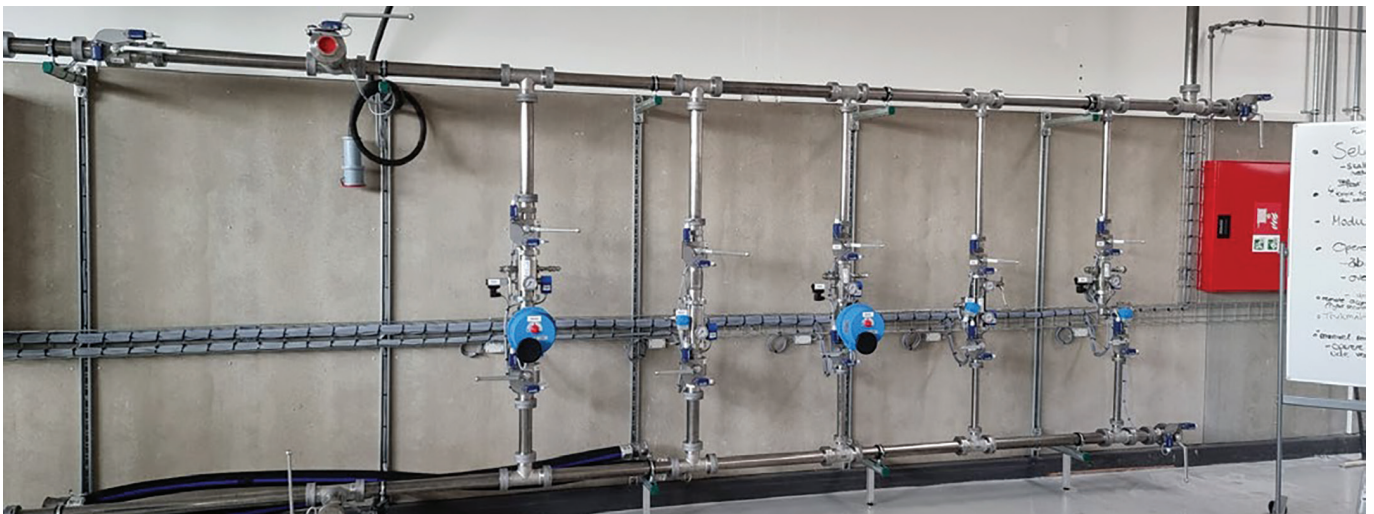

**Published by
Siemens A/S**

Middelfartvej 9C
DK-5000 Odense C
Denmark
Tel. +45 3274 3000
E-mail firesafety.si@siemens.com

We create technology to transform the everyday, for everyone. Our world is changing at an unprecedented rate. Demographic change, urbanization, glocalization, environmental change, resource efficiency, and digitalization are presenting new challenges and opportunities.

Siemens Smart Infrastructure addresses these topics by combining the real and the digital worlds.

Our technology transforms infrastructure, across buildings, electrification, and grids, at speed and scale, enabling collaborative ecosystems to accelerate our customers' digital journey to become more competitive, more resilient, and more sustainable.

siemens.com/smart-infrastructure

Subject to changes and errors. The information given in this document only contains general descriptions and/or performance features which may not always specifically reflect those described, or which may undergo modification in the course of further development of the products. The requested performance features are binding only when they are expressly agreed upon in the concluded contract.

© Siemens 2025