

PYRAMID
www.pyramid.tech

I3200

I3200 - User Manual

Document ID: 2587820336

Version: v9

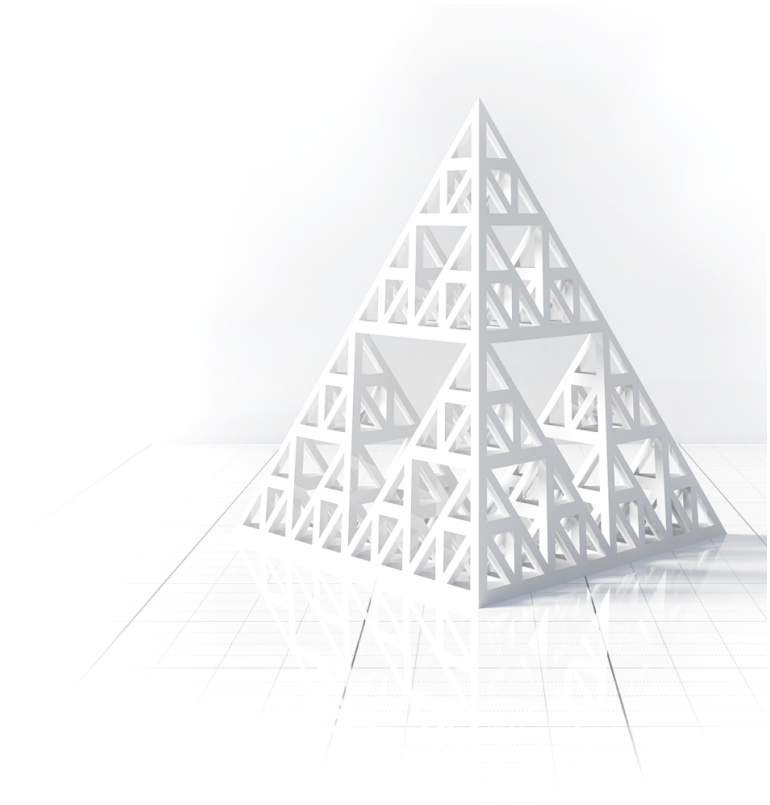

Table of Contents

1	Thirty-Two Channel Digital Electrometer	7
2	References.....	8
3	Document Control.....	9
3.1	Revisions	9
3.2	Approvals	9
3.2.1	Signatures	9
4	Introduction	10
4.1	Safety Information.....	10
4.1.1	Symbols.....	10
4.2	Models	11
4.3	Scope of Supply	12
4.4	Optional Items and Related Products.....	12
4.4.1	Power supplies.....	12
4.4.2	Signal cables and control cables	14
4.4.3	Data cables	14
4.4.4	Cable sets.....	14
4.4.5	Fiber-optic loop controllers and adaptors	14
4.5	Intended Use and Key Features	14
4.5.1	Intended Use.....	14
4.5.2	Key Features	14
4.6	Specification	15
5	Installation	19
5.1	Mounting	19
5.1.1	Mounting orientation	19
5.2	Grounding and power supply	19
5.3	Connection to signal source.....	19
5.3.1	Typical setup.....	19
5.3.2	Signal cables	20
5.3.3	Signal current path	21
6	Getting Started in ASCII Mode.....	24
7	Using the PTC DiagnosticG1 Host Program	29
7.1	Connecting the I3200 to the Host Computer.....	29
7.2	Installing and Using the PTC DiagnosticG1 Program.....	32

7.2.1	Discovering connected devices.....	32
7.2.2	Data tab.....	35
7.2.3	Setup tab.....	39
7.2.4	Device tab.....	43
8	USB Installation.....	46
9	Choosing ASCII or Binary Modes.....	50
10	Using the PTC DiagnosticG2 Host Program.....	51
10.1	Installing the PTC Diagnostic G2.....	51
10.2	Running the PTC Diagnostic G2.....	51
10.2.1	Discovering devices.....	51
10.2.2	Data analysis pane.....	54
10.2.3	Setup panes.....	55
10.2.4	Calibration pane.....	56
10.2.5	Calibration pane.....	57
11	How the I3200 Works - An Overview.....	58
12	Principle of Operation.....	63
12.1	Gated Integrators.....	63
13	Calibration and Self-test.....	66
13.1	Calibration.....	66
13.1.1	Calibration source.....	66
13.1.2	Automatic Self-Calibration.....	66
13.1.3	Using the calibration current source to identify cross-talk.....	66
13.2	Continuity test signal.....	66
13.3	Flat Field Compensation.....	69
13.3.1	Obtaining flat field compensation parameters.....	69
13.3.2	Applying flat field compensation.....	70
14	Making Measurements.....	72
14.1	Current and charge ranges.....	72
14.2	Integrator Control.....	72
14.2.1	Integrator time parameters.....	72
14.2.2	Dynamic feedback capacitor selection.....	74
14.3	Continuous Current Measurement.....	74
14.4	Charge Accumulation Modes.....	75
14.4.1	No correction.....	76
14.4.2	Reset time interpolation.....	76

14.4.3	Lossless accumulation technique	76
14.5	Time Resolved Measurements	78
14.5.1	Standard Mode and FastMode.....	78
14.5.2	Example of time-resolved data	79
14.5.3	Recovering time resolution from the raw data	80
14.5.4	Low pass filtering due to input impedance	81
14.6	Effect of Cable Capacitance on Measurement Accuracy	82
14.7	Data Readout and Buffering	83
14.7.1	Data readout and buffering in ASCII mode	83
14.7.2	Data readout and buffering in binary mode.....	84
14.7.3	Data readout and buffering in A500 FastMode.....	84
14.8	Triggering.....	85
14.8.1	Trigger sources.....	85
14.8.2	Illustration of ExternalStart mode	86
14.8.3	Illustration of ExternalStartStop mode	86
14.8.4	Illustration of ExternalStartHold mode	87
14.9	Background offsets	88
15	High Voltage Supply	90
15.1	Setting the High Voltage Supply	90
15.2	Changing the High Voltage Supply Range and Polarity	91
16	Using the Actuator Control Connector	93
17	EPICS Interfacing	94
17.1	What is EPICS?	94
17.2	Installing and Configuring IG2	95
18	Dose Control Option	97
18.1	Overview of operation	97
18.2	Control signal.....	98
18.3	Special ASCII commands.....	98
18.4	Example beam control session	99
19	Connectors	102
19.1	Front Panel Connectors	102
19.1.1	Actuator.....	102
19.1.2	Signal Inputs 1-16	102
19.1.3	Signal Inputs 17-32.....	103
19.1.4	Auxiliary HV Out.....	103

19.2	Rear Panel Connectors	104
19.2.1	USB Communications.....	104
19.2.2	RS-232 Communications	104
19.2.3	Fiber-Optic Communications:	104
19.2.4	Optical Trigger / Gate Input.....	104
19.2.5	Electrical Trigger / Gate Input	104
19.2.6	Power Input	104
19.2.7	Ground Lug.....	105
20	Controls and Indicators	106
20.1	Front panel controls	106
20.2	Rear panel controls	106
20.2.1	Mode switch.....	106
20.2.2	Address switch	106
20.3	Front panel indicators	106
20.3.1	Xmit	106
20.3.2	Rcv	107
20.3.3	Status.....	107
20.3.4	Link.....	107
20.3.5	Power.....	108
20.3.6	HV on	108
20.4	Rear panel indicators	108
20.4.1	USB	108
20.4.2	RS-232.....	108
20.4.3	Optical.....	108
21	Communications Interfaces	109
22	Communications Protocols	111
22.1	Overview	111
22.2	ASCII Protocol - SCPI.....	111
22.2.1	Messages	111
22.2.2	Status registers.....	112
22.2.3	Host Commands	114
	ADDRESSING DEVICES	114
	IEEE 488.2 MANDATORY COMMANDS.....	114
	IEEE 488.2 optional commands.....	115
	IEEE 488.2 required commands.....	115
	I3200 COMMANDS.....	116
22.3	ASCII Protocol – Terminal Mode	125

22.4	Binary protocol	125
23	Techniques for Making Low Current Measurements	126
23.1	Guarding and screening.....	126
23.2	Temperature	128
23.3	Triboelectric effects.....	128
23.4	Battery Effects.....	128
23.5	Piezoelectric Effects	128
23.6	Integration Period and Synchronization.....	128
23.7	Summary	130
24	Software Updates	131
24.1	FPGA firmware updates.....	131
24.2	PIC firmware updates	132
25	Troubleshooting	134
26	Maintenance	137
27	Returns Procedure	138
28	Support	139
29	Disposal.....	140
30	Declaration of Conformity.....	141

1

Thirty-Two Channel Digital Electrometer



Document ID: 2587820336

Author	W. Nett
Owner	Project Lead
Purpose	Provide instructions to the end user regarding intended use of the product.
Scope	I3200 operation and usage
Intended Audience	Owners of an I3200 device
Process	Standard Manual Creation Process
Training	NOT APPLICABLE

2 References

Document	Document Id	Author	Version

3 Document Control

3.1 Revisions

Version	Description	Saved by	Saved on
v9	Removed outdated references	Duyen Nguyen	Aug 11, 2025 9:54 AM
v8	Deprecated the PGA	Harvey Jules Nett	Aug 29, 2023 8:22 PM

3.2 Approvals

This document has been reviewed and approved as follows.



Document Control Not Reviewed

Current document version: v.2

No reviewers assigned.

3.2.1 Signatures

for most recent document version

Monday, Aug 11, 2025, 10:27 AM UTC

Duyen Nguyen signed ; meaning: Review

Monday, Aug 11, 2025, 09:59 AM UTC

Phan Thi Thao Nguyen signed ; meaning: Review

4 Introduction

4.1 Safety Information

This unit is designed for compliance with harmonized electrical safety standard EN61010-1:2000. It must be used in accordance with its specifications and operating instructions. Operators of the unit are expected to be qualified personnel who are aware of electrical safety issues. The customer's Responsible Body, as defined in the standard, must ensure that operators are provided with the appropriate equipment and training.

The unit is designed to make measurements in **Measurement Category I** as defined in the standard.

CAUTION. According to installed options the I3200 can generate high voltages as follows, present on the central conductor of the SHV (Safe High Voltage) connector.

- + or – 2000 V DC at 0.5 mA maximum.
- or
- + or – 1000 V DC at 1.0 mA maximum
- or
- + or – 500 V DC at 2.0 mA maximum
- or
- + or – 200 V DC at 5.0 mA maximum

The hazardous live voltages on the SHV central conductor are not accessible under the definitions of EN61010 but may nevertheless give a noticeable shock if misuse were to lead you to come into contact with them. The user must therefore exercise appropriate caution when using the device and when connecting cables. Power should be turned off before making any connections.

In applications where high energy charged particle beams can strike electrodes which are normally connected to the I3200, voltages limited only by electrical breakdown can build up if the I3200 is not connected to provide the earth return path. The user must ensure that a suitable earth return path is always present when the particle beam may be present.



The unit must not be operated unless correctly assembled in its case. Protection from high voltages generated by the device will be impaired if the unit is operated without its case. Only Service Personnel, as defined in EN61010-1, should attempt to work on the disassembled unit, and then only under specific instruction from Pyramid Technical Consultants.







The unit is designed to operate from +24 VDC power, with a maximum current requirement of 1250 mA including power supplied to remote 24 VDC devices. A suitably rated power supply module is available as an option. Users who make their own power provision should ensure that the supply cannot source more than 3000mA.

A safety ground must be securely connected to the ground lug on the case.

Some of the following symbols may be displayed on the unit, and have the indicated meanings.

4.1.1 Symbols

Symbol	Meaning
	Direct current
	Earth (ground) terminal

Symbol	Meaning
	Protective conductor terminal
	Frame or chassis terminal
	Equipotentiality
	Supply ON
	Supply OFF
	CAUTION – RISK OF ELECTRIC SHOCK
	CAUTION – RISK OF DANGER – REFER TO MANUAL

4.2 Models

Device Model	Description
I3200	Thirty-two channel gated integrator electrometer with 10pF and 1000pF feedback capacitors.
-XP20/10/5/2	Add positive 0 to 2000V / 1000 V / 500 V / 200 V auxiliary bias output
-XN20/10/5/2	Add negative 0 to 2000V / 1000V /500 V / 200 V auxiliary bias output
-DQ	Add dose control option

Example:

I3200-XP10-DQ	I3200 with 1000V positive auxiliary bias output and dose control firmware option.
---------------	---

4.3 Scope of Supply

End user customers purchasing direct from Pyramid receive the following items:

I3200 model as specified in your order.

USB memory stick containing:

- Data sheet
- User manual
- PTC DiagnosticG1 host software for Windows
- PTC DiagnosticG2 host software for Windows
- IG2 EPICS channel access server
- Copy of installed firmware
- USB drivers and utilities

ADAP-MINIDIN-D9F adaptor for serial port

ADAP-USB-RS232 adaptor

PSU24-40M-1 24 V power supply

Optional items as specified in your order.

OEM purchasers receive the I3200 unit plus any other items that are explicitly ordered.

4.4 Optional Items and Related Products

4.4.1 Power supplies

PSU24-40M-1 +24 VDC 40W PSU (universal voltage input, plug receptacle for standard IEC C14 socket) with output lead terminated in 2.1mm threaded jack.



PD-8 Eight output +24 VDC power supply unit, 19" rack mounting.

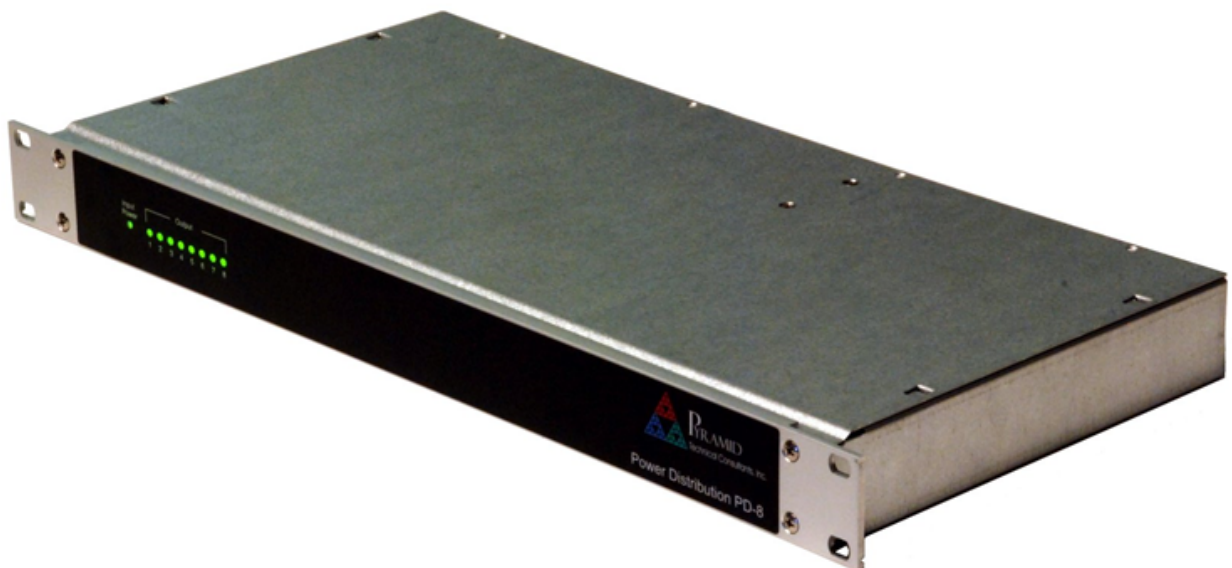

4.4.2 Signal cables and control cables

- CAB-D25F-xx-D25M cable multiway, signal, DSub 25 pin male to DSub 25 pin female, xx feet long. Two required to connect 32 channels.
- CAB-D25F-xxLN-D25M cable multiway, anti-triboelectric, DSub 25 pin male to DSub 25 pin female, xx feet long. Optional cable for low-noise operation in environments where the cables may move. Two required to connect 32 channels.
- CAB-D9F-xx-D9M cable, low-noise signal, DSub 9 pin male to DSub 9 pin female, xx feet long. Pneumatic actuator control.
- CAB-SHV-xx-SHV: cable, coax, SHV to SHV, xx feet long. Detector bias voltage.

4.4.3 Data cables

- CAB-MINIDIN-D9F RS-232 6 pin miniature DIN male to 9 pin Dsub female adaptor.
- CAB-ST-xxHCS -ST Fiber-optic cable 200 um silica fiber ST terminated with color-coded boots, xx feet long. Pair of cables required for a single point to point connection.

4.4.4 Cable sets

- CAB-SET-BPM-xx cable set, comprising two CAB-D25F-xx-D25M, one CAB-D9F-xx-D9M, one CAB-SHV-xx-SHV, xx feet long.

4.4.5 Fiber-optic loop controllers and adaptors

- A360 fiber-optic loop controller / Ethernet adaptor.
- A500 intelligent real-time cell controller for five or ten loops with Ethernet interface.
- A560 intelligent real-time cell controller for five or ten loops with Ethernet interface.
- X44 fiber optic repeater, four inputs, four outputs for communications passthrough.
- X14 fiber optic fanout, one input, four outputs for trigger distribution.

4.5 Intended Use and Key Features

4.5.1 Intended Use

The I3200 is intended for the measurement of small charges or corresponding currents (from pA to μ A) generated by devices such as ionization chambers, in-vacuum wire grid arrays, multiwire proportional chambers and photodiode arrays. The I3200 has design features which make it tolerant of electrically noisy environments, but the place of use is otherwise assumed to be clean and sheltered, for example a laboratory or light industrial environment. The unit may be used stand-alone or networked with other devices and integrated into a larger system. Users are assumed to be experienced in the general use of precision electronic circuits for sensitive measurements, and to be aware of the dangers that can arise in high-voltage circuits.

The -DQ option provides a feature for measuring and controlling the delivery of a pre-determined amount of charge. By suitable calibration, this can be related to the dose delivered to a target. This feature is intended for research applications. It is not intended for delivery of therapeutic dose to human subjects.

4.5.2 Key Features

Highly sensitive charge and current measuring system.

Dynamic range 0.1 pA to 100 μ A.

Integration periods down 100 μ sec and below.

Compact 1U 19" configuration.

Thirty-two fully-parallel gated integrator channels.

One dual-input ADC for every four input channels. Providing simultaneous conversion across sixteen channels and all channels within 4 μ sec.

Fiber optic and BNC/TTL external gate inputs for system-wide acquisition synchronization.

Multiple data acquisition modes

- continuous current measurement
- continuous charge accumulation
- no lost charge integration
- external gated measurements with various responses to the gate signal

Built-in high-precision calibration check current source which can be switched to each channel.

Fully-automatic internal calibration sequence.

Built-in switched 5V test voltage for connection to external resistor arrays, for continuity checking.

Dose control option for research applications.

RS-232, USB and fast fiber-optic serial interfaces built-in. Selectable baud rates.

Can be operated in a fiber-optic serial communication loop with up to fourteen other devices.

100BaseT Ethernet available through the A360, A500 and A560 controllers.

ASCII and binary serial data formats.

Switched +24 VDC output suitable for driving a pneumatic actuator solenoid plus two digital inputs suitable for reading limit switches.

Auxiliary HV output option up to + or – 2000 VDC.

Downloadable firmware updates from host computer.

4.6 Specification

Inputs	Thirty-two, independent parallel
Input stage feedback capacitors	Two, software selectable
Integration time	Adjustable, 100 μ s minimum, 10 s maximum. With A500 in binary fast mode, 20 μ sec minimum.
Input noise current	< 20 fA rms + 1 fA rms per pF input load up to 100 pF load (1 second integration, 10 pF capacitor) at \leq 30C
Input background current (corrected)	< 200 fA, 25 C for 100 seconds after nulling < 300 fA, 35 C after for 8 hours after nulling (excluding external background current sources)
Input background current (absolute)	< 5 pA, 30 C without zero offset correction < 10 pA, 35 C without zero offset correction (excluding external background current sources)
Stability	Output drift < 100 fA / hour at 30 C
Drift	< 0.5% over 12 hours.
Calibration current	500.00 (+/- 0.1) nA (rev 2 hardware and earlier) 83.333 (+/- 0.02) nA (rev 3 hardware)
Digitization	16 bit over +/- 10 V PGA output range, 1 MHz. Eight parallel ADC channels, each with two parallel sample and hold circuits.

Linearity	Deviation from best fit line of individual readings < 0.1% of maximum current or charge reading for given feedback capacitor and integration time setting.
Simultaneity	Odd-numbered channels all converted within 0.3 μ sec of each other. Even-numbered channels all converted within 0.3 μ sec of each other. Odd-numbered channels conversions offset by \leq 4 μ sec from even numbered channel conversions.
Local buffering	Up to 300 samples, each 32 channels, can be stored in I3200 buffer memory at maximum acquisition rate.
External accuracy	0.25% of full scale charge or current for the selected capacitor and integration time. Capacitive load \leq 500 pF.
Dose control time resolution (option)	1 msec
Dose control accuracy (option)	Better than 1 % typical (measured charge relative to target) with background offset subtraction
Auxiliary HV PSU (option)	0 to 2000 V / 1000 V / 500V / 200V programmable 10 bit resolution, 1W max output power. Line and load regulation < 0.01% Noise and ripple <0.01% of full scale.
External gate	1. 0 / +5 V (TTL level), 2 kohm input impedance. 2. Fibre optic input ST bayonet,
Power input	+24 VDC (+/-2 V), 750 mA (maximum excluding current supplied to actuator solenoid). 1250 mA maximum recommended including current supplied to external devices.
Case	1U 19" rack mounting, 250 mm deep.
Case protection rating	The case is designed to rating IP43 (protected against solid objects greater than 1mm in size, protected against spraying water).
Weight	2.7 kg (6.0 lb).
Operating environment	0 to 35 C (15 to 25 C recommended to reduce drift and offset) < 70% humidity, non-condensing vibration < 0.1g all axes (1 to 100 Hz) Vibration introduces noise to the measurement by triboelectric effects. The vibration and flexing of cables should be reduced to the absolute practical minimum.
Shipping and storage environment	-10 to 50C < 80% humidity, non-condensing vibration < 2 g all axes, 1 to 100 Hz
Dimensions	(see figures 1 and 2).

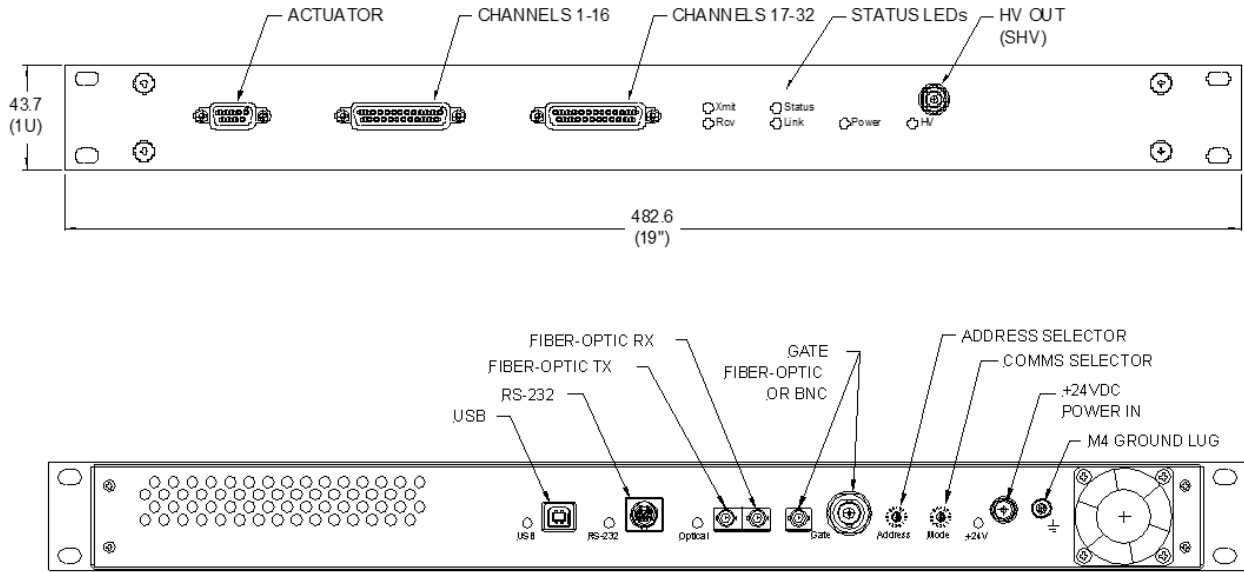

1: I3200 front and rear panels. Dimensions mm.

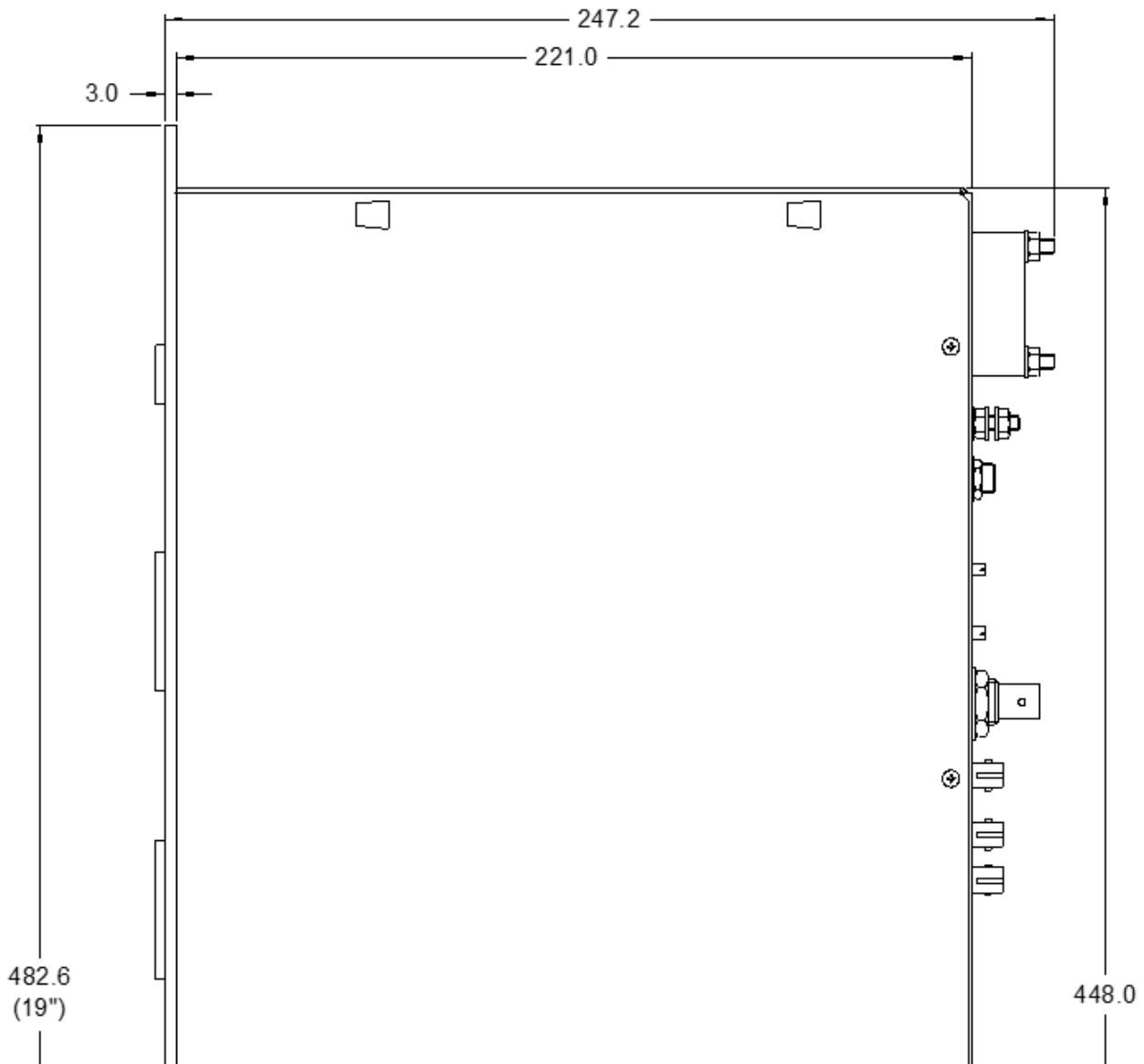

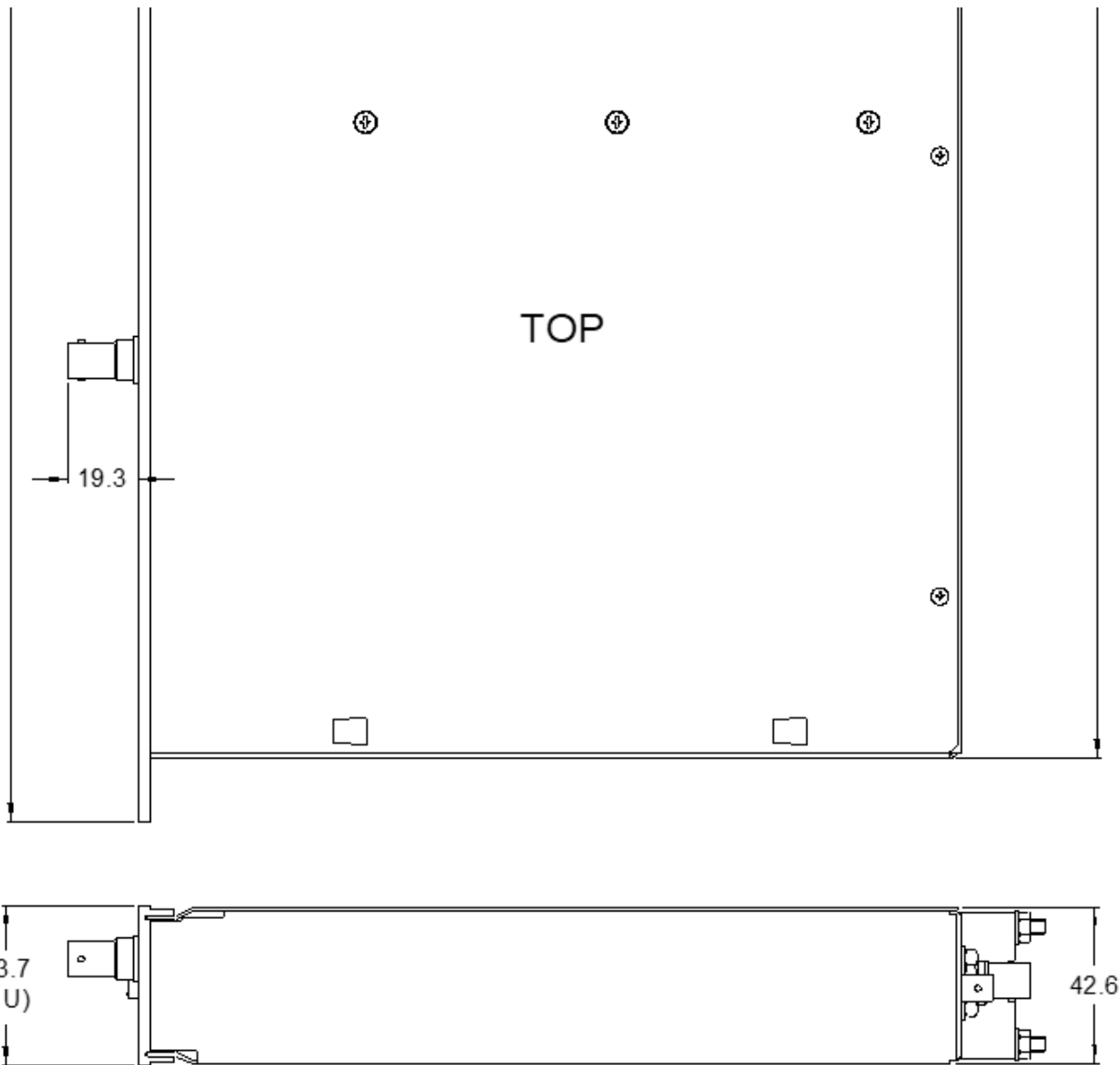

2 : I3200 case plan and side views. Dimensions mm.

5 Installation

5.1 Mounting

The I3200 is intended for 19" rack mounting, but may be mounted in any orientation, or may be simply placed on a level surface. A fixed mounting to a secure frame is recommended in a permanent installation for best low current performance, as this can be degraded by movement and vibration.

The mounting position should allow sufficient access to connectors and cable bend radii. 100 mm clearance is recommended at front and back of the device.

Best performance will be achieved if the I3200 is in a temperature-controlled and vibration-free environment. No forced-air cooling is required in addition to the unit's built-in fan, but free convection should be allowed around the back and sides of the case.

5.1.1 Mounting orientation

The I3200 may be mounted in any orientation. It may be mounted on a rotatable gantry if suitably secured. Take care that signal cables do not flex excessively during rotation.

5.2 Grounding and power supply

A secure connection should be made using a ring lug, from the M4 ground lug to local chassis potential. This is the return path for any high voltage discharge passing via the I3200.

+24 VDC power should be provided from a suitably-rated power supply with the following minimum performance:

Output voltage	+24 +/- 0.5 VDC
Output current	1250 mA minimum, 3000 mA maximum
Ripple and noise	< 100 mV pk-pk, 1 Hz to 1 MHz
Line regulation	< 240 mV

The I3200 includes an internal automatically re-setting PTC fuse rated at 1.1 A. Current supplied to an external actuator or other device does not pass through this fuse. However the power supply should in no circumstances be rated higher than the connector limit of 5 A, and a maximum of 3 A is recommended.

5.3 Connection to signal source

5.3.1 Typical setup

Figure 3 shows a typical installation in schematic form. Thirty-two readout electrodes forming one electrode at ground potential in a signal source such as a parallel plate ionization chamber are connected to the I3200 inputs via low-noise multi-way cables. In this example, the other electrode is biased by the auxiliary external output. An array of high value resistors convert the test output voltage from the I3200 into currents that can be read back to check signal path continuity. A gate signal generated by a remote timing controller, for example, triggers the I3200 to start measuring data.

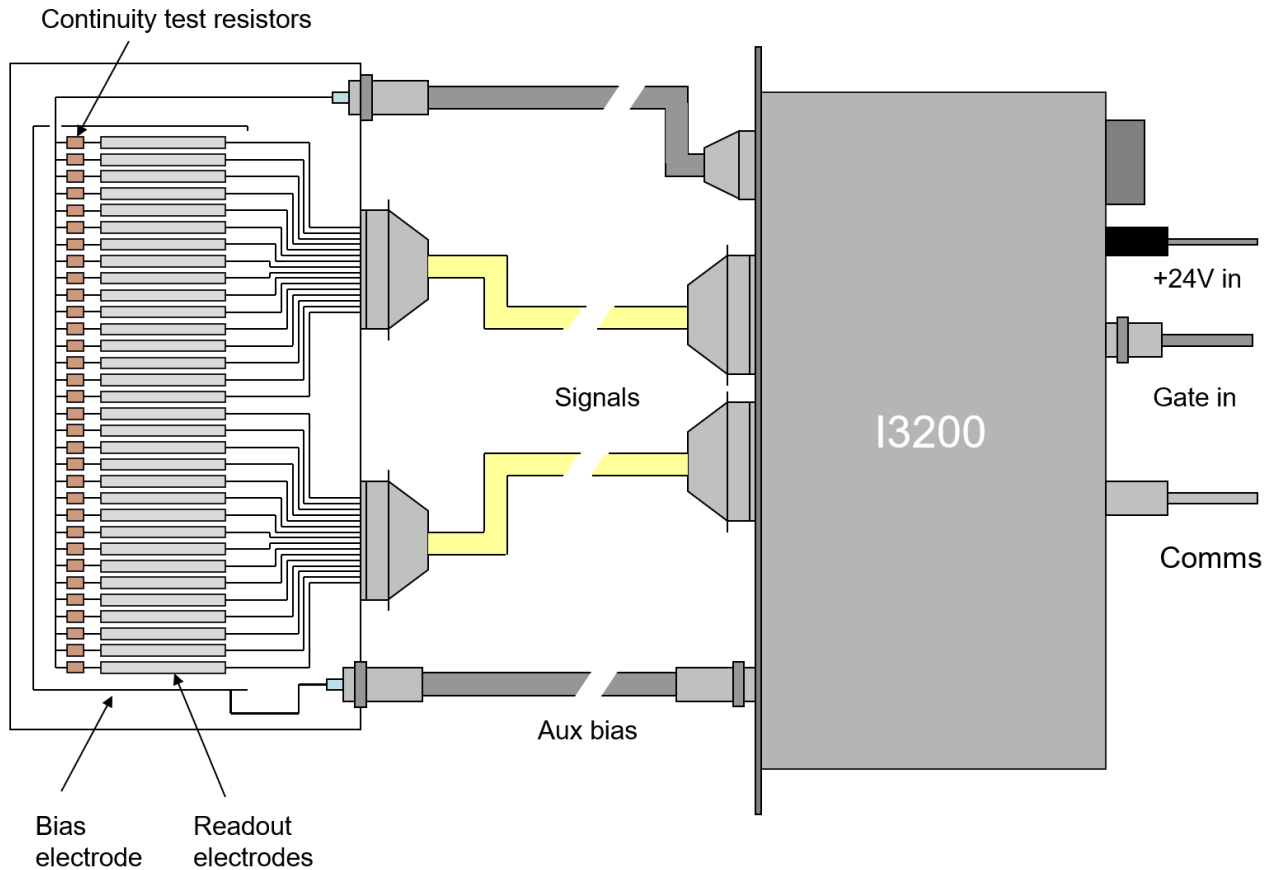

3 : Schematic sample I3200 installation

Refer to section 25 in this manual for general guidance on making low current measurements. The I3200 should be located as close to the source of the signal as reasonably possible. Long signal cables increase the chances of seeing unwanted signals and noise, and the capacitive load they introduce can affect accuracy. A maximum length of 5 m and maximum capacitive load per channel of 750 pF is advised. Longer cables may be used up to a maximum of 20 m, but the lowest detectable current will be increased and accuracy will be degraded.

5.3.2 Signal cables

16-way low-noise cable with the minimum practicable capacitance is recommended for very low current measurement, terminated in good-quality 25-way D subminiature plugs at the I3200 end. Special anti-triboelectric low-noise cable is made with semiconductive coatings on insulators where cable flexing can generate free charge (the triboelectric effect). You can obtain suitable cable from Pyramid Technical Consultants, Inc. Low current measurements can be made with standard cable, but you must take particular care that the cable cannot move or vibrate for several minutes before or during low current measurements.

The cable should have an overall screen of good quality and individually insulated cores. If there is an anti-triboelectric coating, this should be cleared back from the end of the insulator on each core by a about 2mm to ensure that the cores cannot connect to each other through it.

Generally you should connect the screen to the connector shell at each end. If there is a drain wire in the cable, this should be connected to AGnd at the I3200 and to the current return point at the detector. AGnd and the chassis are connected within the I3200.

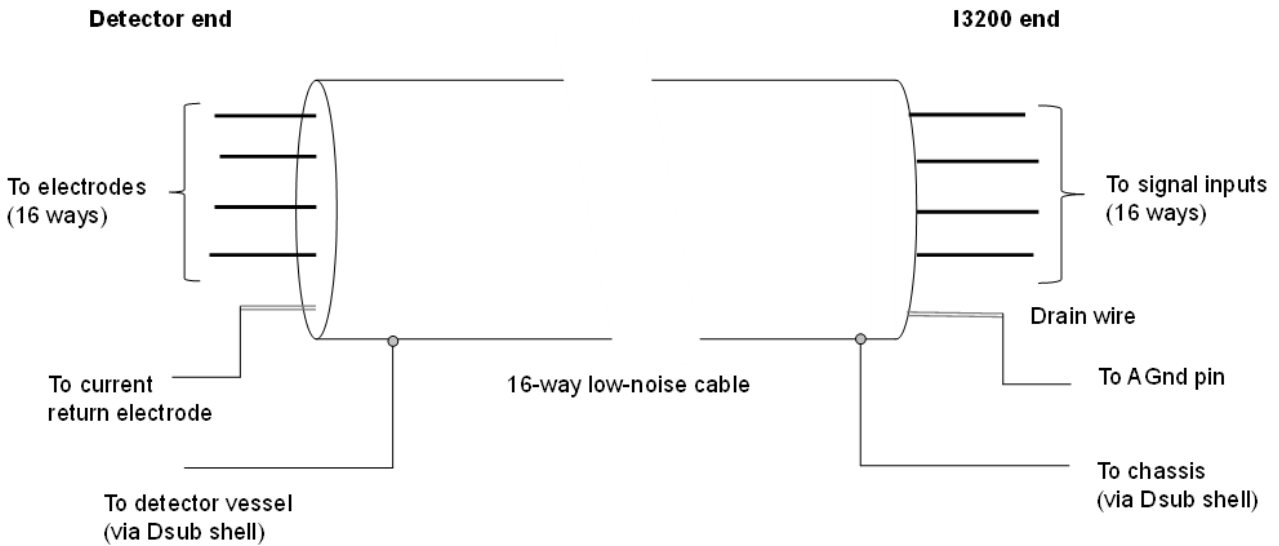

4 : Cable screening recommendation

In some noise environments it is beneficial to break potential ground loops by only making the screen at the I3200 end. Generally you can only determine the optimum arrangement for noise by experimentation.

In some low-noise cables the conductors are individually shielded. This gives additional screening, but at the expense of added capacitive load. The shields should be joined together and connected to one or more of the analog ground pins at the I3200 for each of the 16-way input connectors. With this type of cable it is generally best to start with the individual screens and the overall screen only connected at the I3200 end, but as before, only practical testing can decide the optimum arrangement.

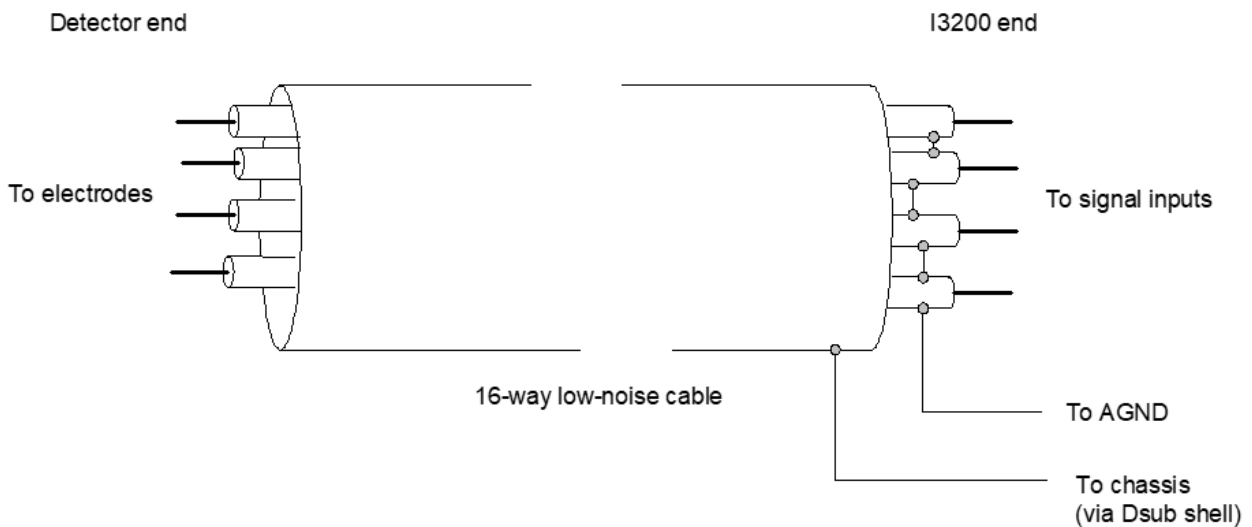

5 : Alternative cable screening recommendation – individually screened cores

5.3.3 Signal current path

The currents measured by the I3200 must be allowed to return to their point of generation. Depending upon the application, the return path may be via the high voltage supply, and/or via the chassis. If there is no return path, then you will see no current, or erratic readings. Note that you may see current initially if there is no return path, especially if the signal is small, as charge can be provided from various stray capacitances, but this may fall away or become unstable.

The currents you are measuring pass along the cable inner conductors to the I3200 inputs. The current for the operational amplifier action comes from the local circuit ground (AGND) via the power supply providing the voltage rails in the I3200.

In the case of an ionization chamber or similar device, where the I3200 is providing the bias to another electrode, the subsequent return path for the current is through the HV supply (figure 6) to complete the circuit back to the biased electrode. If the supply is not enabled, then it appears as an impedance of approximately $0.3V \text{ kohm}$, where V is the rating of the supply.

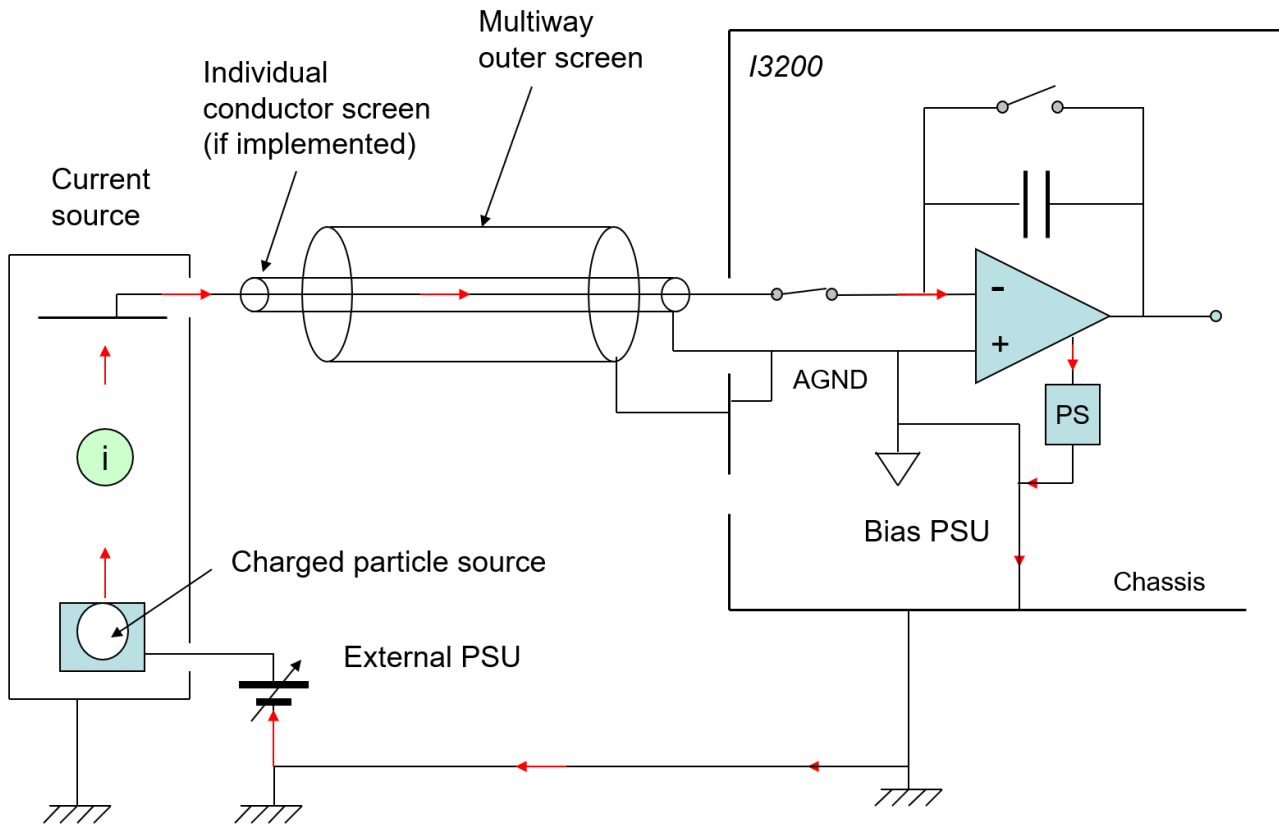

6 : Circuit for measured current when using the internal HV supply to bias a detector.

In the case where you are using an independent external energy source to drive the current source, such as an independent HV supply, the current must return to this source. It may be remote from the place where the current measurement is being made, for example the current measured by an electrode in a charged particle beamline actually originates in the ion or electron source, which could be many metres away.

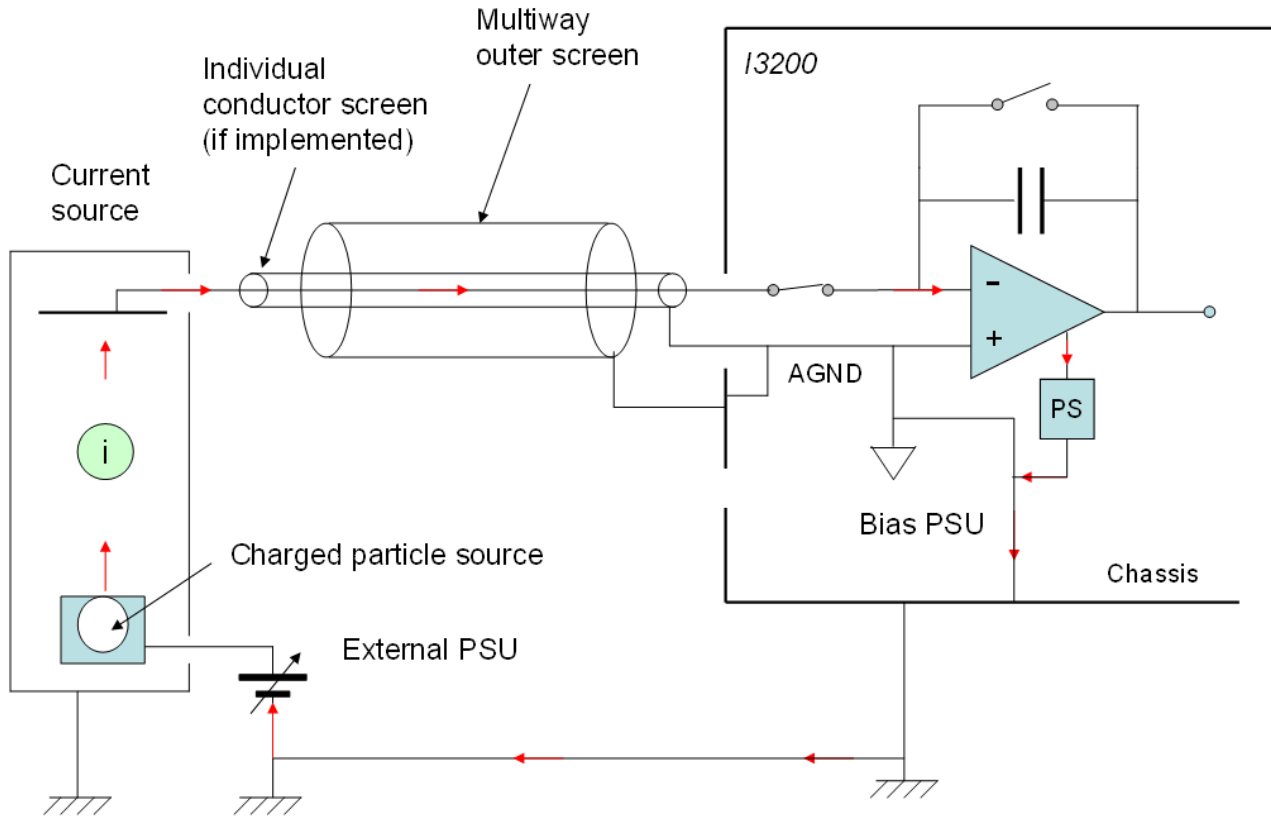

7 : Circuit for measured current when using an external HV supply to bias a detector.

Generally, the circuit will be completed through intentional or unintentional connections of the components to the laboratory ground, but if you are ever unable to measure a current where you expect to, it is worth checking that there are no breaks in the current circuit.

6 Getting Started in ASCII Mode

Before installing the I3200 in its final location, and if it is the first time you have used an I3200, we recommend that you familiarize yourself with its operation on the bench. You can check the unit powers up correctly, establish communications, run the internal calibration procedure, and read the internal calibration current.

The most basic level of operation, which requires nothing more than a terminal program and a serial port on the host computer, is to use the RS-232 ASCII communications mode. This chapter takes you through simple setup tests using ASCII commands. To explore the full capability of the I3200, it is more convenient to use one of the Pyramid Technical Consultants, Inc. Diagnostic Host programs that are supplied with the unit, and this is covered in the next chapter.

1. Inspect the unit carefully to ensure there is no evidence of shipping damage. If there appears to be damage, or you are in doubt, contact your supplier before proceeding.
2. Connect 24 V DC power but no other connections. The power LED should illuminate when the power is applied, the status and link LEDs will cycle through green, orange and red, and the xmit LED will flash .
3. Make a connection to a PC serial port. Most laptop computers no longer provide a physical RS-232 port. The ADAP-USB-RS232 adaptor (left in the picture below) has been qualified for adaption of a standard USB port to RS-232, and the ADAP-MINIDIN-D9F adaptor (right in the picture below) then allows a regular DSub 9 pin cable with pin to pin connections to be used, as shown in the following picture.



8 : RS-232 connection arrangement using USB and mini-DIN adaptors.

If you have a computer with a standard 9 pin serial port, a three wire lead terminated in a six-pin mini-DIN male connector (PS/2 mouse type) and a nine-pin D female will be sufficient to make the link.

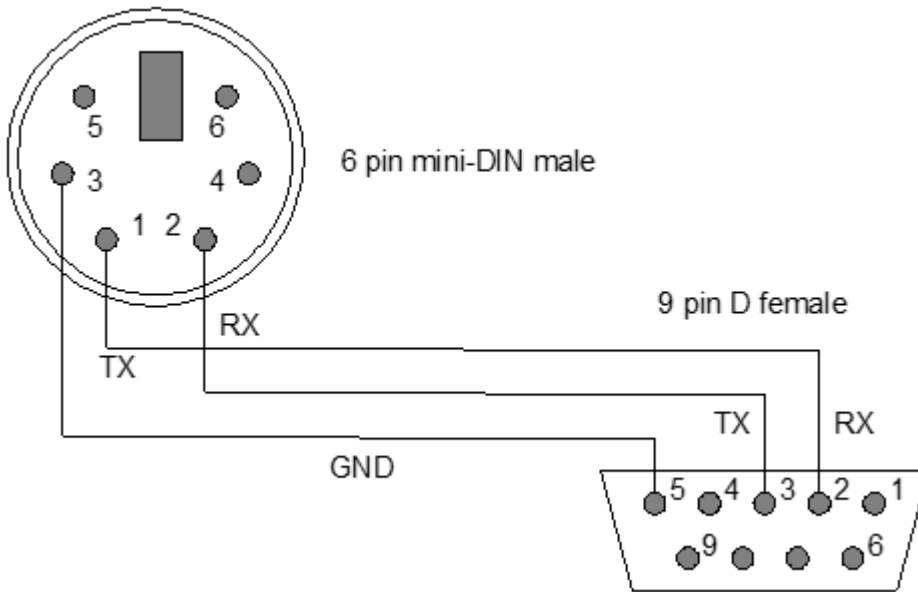

9 : RS232 connection cable from the I3200 to a PC serial port (DB9). Pins are shown looking at the face of the connectors.

When the DIN connector is pushed home in the I3200, the rear panel “optical” LED should extinguish and the “RS232” LED should illuminate. Connecting to this port forces the I3200 to be a listening device.

4. Set the mode rotary switch to position “6” (ASCII communication, 115 kbps).
5. Set up a terminal session using a suitable program. On older PCs you can use Windows Hyperterminal, or there are various freeware and shareware alternatives such as Realterm and puTTY. If you have an older Windows system, you can move Hyperterminal by copying the files hypertrm.dll and hypertrm.exe to your newer system. You will of course need a serial port, or a USB or Ethernet to RS-232 converter. A suitable Hyperterminal setup file is provided on the I3200 USB memory stick.

If you have a hardware serial port, it will most likely be COM1. If you use a USB-RS232 converter, you will need to find which port has been assigned by the operating system. This can be done in Windows by finding the converter on the Devices and Printers screen and displaying its properties. COM5 was assigned in the examples shown below.

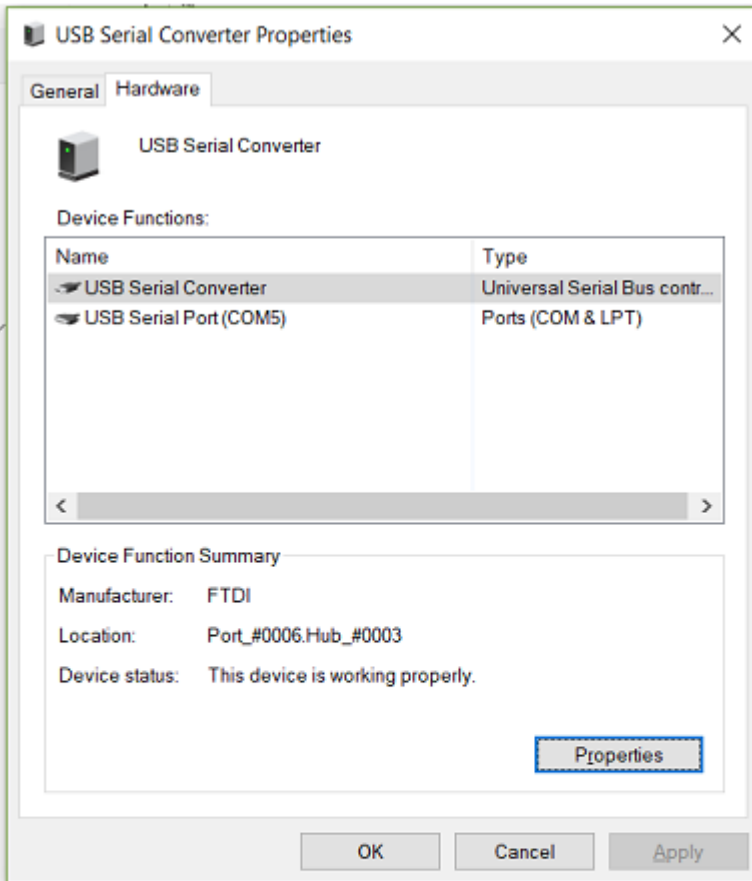

Unspecified (2)



10 : Discovering the COM port assigned to a USB-RS232 converter.

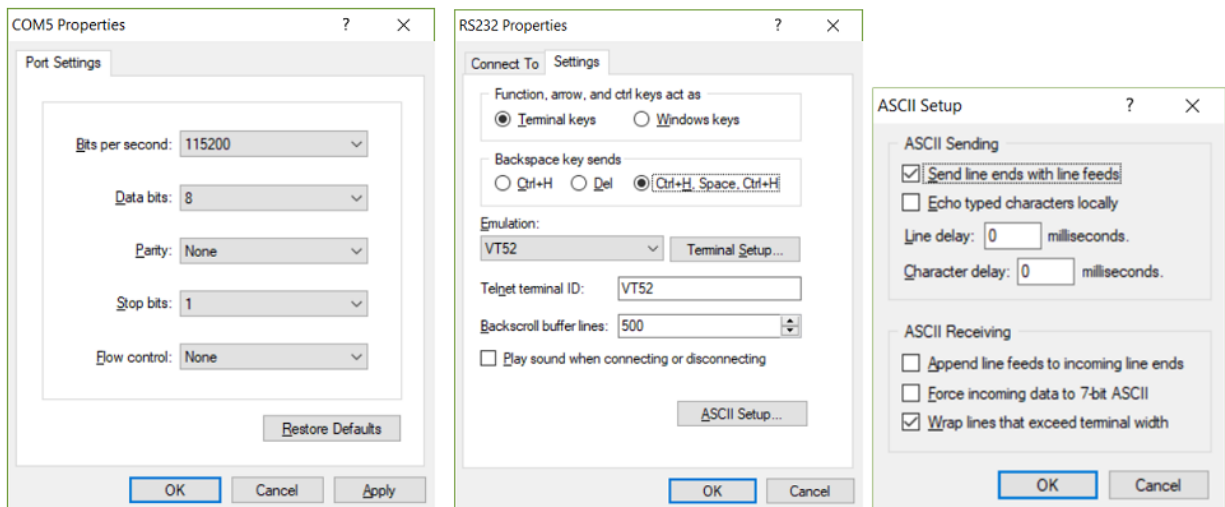

11 : Hyperterminal COM port setup.

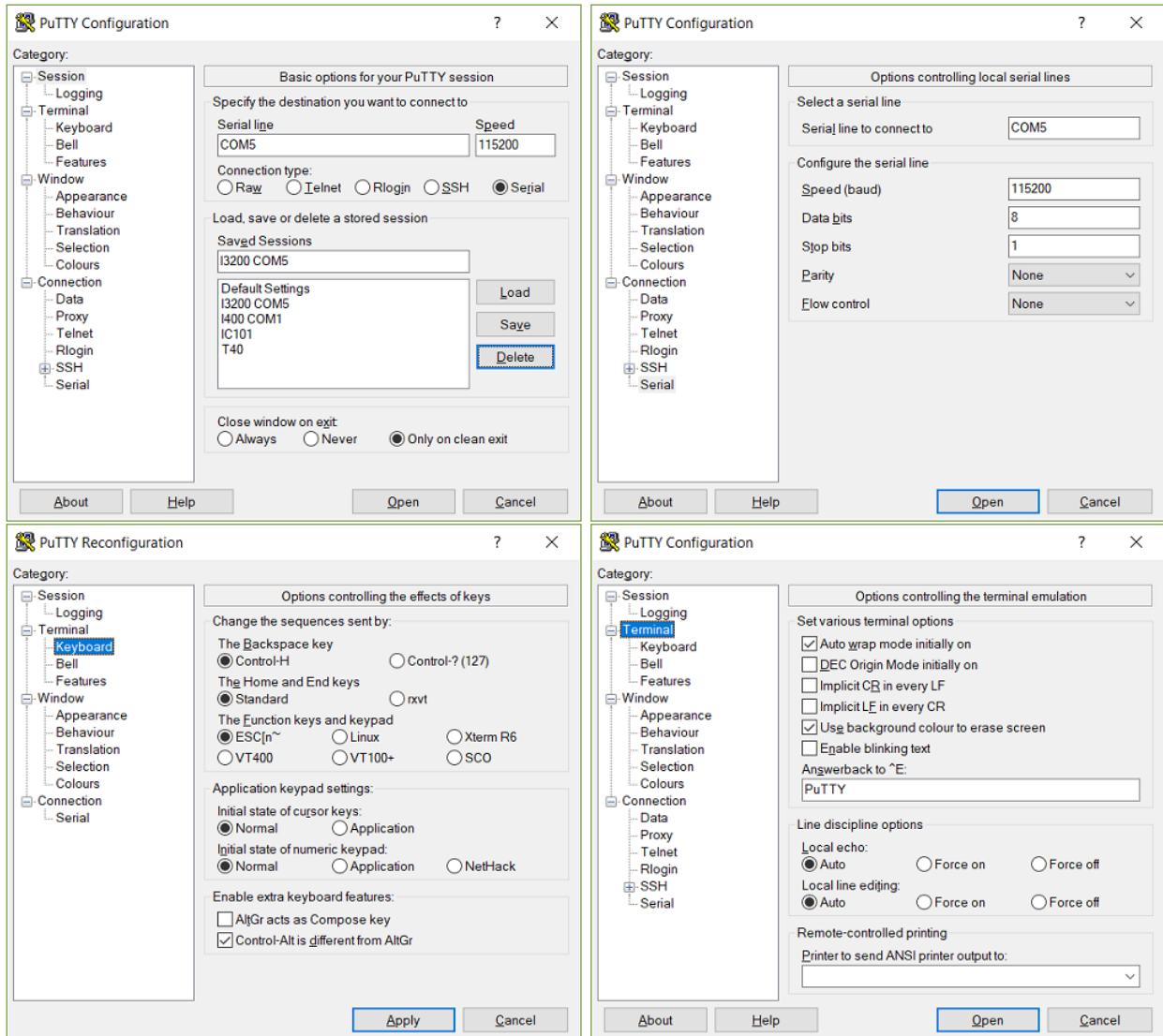

12 : Suggested puTTY terminal settings

The following session example assumes a puTTY connection. To send a string to the I3200, it should be terminated with a linefeed character (10, 0xA) which is sent by pressing ctrl-J.

The I3200 starts up in terminal mode, so you will receive a response for every message. If there is no immediate text response to the command, for example when setting a parameter or starting a measurement, then the I3200 will respond with "OK". It can also be configured into standard SCPI mode if you wish, but then only query messages will receive a response. See *Communications Protocols for more details*.

6. Send **#?<ctrl-J>** to query the active listener. The I3200 will respond with its loop address plus a checksum. If you hear your computer's bell sound when you send the string, the I3200 did not understand it, probably because there was a typing error. If the I3200 does not echo characters correctly, either the terminal settings or the I3200 switch settings are likely to be wrong. Check them and retry until you see the characters echo correctly. If you make any errors while typing, use the backspace key and re-type from the error. The checksum can be suppressed if required – see section 24.
7. Send ***idn?<ctrl-J>**. The characters can be upper or lower case. The I3200 should respond with its hardware revision, serial number and firmware versions.
8. Send **calib:gain<ctrl-J>**. If the I3200 is in terminal mode (the default) it will respond immediately with "OK", and will perform its internal calibration sequence, which takes about one minute.

9. 10) When the calibration is complete (the front panel link LED is no longer flickering), send **calib:gain? 0<ctrl-J>**. The I3200 will return the gain factors for the thirty-two channels channels for the small feedback capacitor selection.
10. Send **read:curr?<ctrl-J>**. The I3200 will do a measurement and return the integration period it used and the measured current values for each of the channels. The current values should be close to background. The default integration period on power-up is 100 μ seconds. If you repeat **read:curr?<ctrl-J>** a few times you should see the readings change due to background noise.
11. Send **calib:source 5<ctrl-J>**. This turns on the internal calibration current to channel five. Type **read:curr?<ctrl-J>** to read this current. You should see a value very close to 5.0e-7 A (rev 2 and earlier hardware) or 8.33e-8 A (rev 3 hardware).

```

COM5 - PuTTY
#?
9{57}
*idn?
PYRTECHCO,I3200-REV3,0000001646,4.0P/5.3.23{2491}
calib:gain
OK
calib:gain? 0
1.0602e+00,1.0553e+00,1.0520e+00,1.0463e+00,1.0592e+00,1.0491e+00,1.0177e+00,1.0481e+00,1
.0634e+00,1.0599e+00,1.0501e+00,1.0388e+00,1.0523e+00,1.0470e+00,1.0474e+00,1.0485e+00{9305},1.0644e+0
0,1.0559e+00,1.0555e+00,1.0525e+00,1.0653e+00,1.0580e+00,1.0466e+00,1.0517e+00,1.0683e+00,1.0501e+00,1
.0537e+00,1.0581e+00,1.0644e+00,1.0278e+00,1.0473e+00,1.0552e+00,-1{9499}
OK
read:curr?
OK
1.0000e-04 S,-9.7065e-11 A,9.6619e-11 A,6.4208e-11 A,1.2773e-10 A,6.4650e-11 A,6.4033e-11 A,-3.1057e-1
1 A,-3.1986e-11 A,-3.2452e-11 A,9.7037e-11 A,3.2047e-11 A,1.2681e-10 A,3.2114e-11 A,9.5855e-11 A,3.196
6e-11 A,-3.1997e-11 A{11958},3.2482e-11 A,3.2225e-11 A,6.4423e-11 A,3.2119e-11 A,9.7535e-11 A,0.0000e+
00 A,3.1941e-11 A,3.2096e-11 A,-3.2602e-11 A,-9.6141e-11 A,1.2863e-10 A,0.0000e+00 A,-3.2481e-11 A,1.2
546e-10 A,6.3925e-11 A,3.2202e-11 A,0{11212}
OK
read:curr?
OK
1.0000e-04 S,-1.6177e-10 A,0.0000e+00 A,-6.4208e-11 A,-1.2773e-10 A,0.0000e+00 A,-3.2017e-11 A,0.0000e
+00 A,6.3973e-11 A,-1.6226e-10 A,9.7037e-11 A,-1.6023e-10 A,-6.3406e-11 A,3.2114e-11 A,6.3904e-11 A,-1
.5983e-10 A,-6.3995e-11 A{12040},1.2993e-10 A,0.0000e+00 A,-1.6106e-10 A,0.0000e+00 A,-3.2512e-11 A,-6
.4574e-11 A,-6.3881e-11 A,1.2838e-10 A,6.5204e-11 A,9.6141e-11 A,-3.2157e-11 A,1.2916e-10 A,0.0000e+00
A,6.2731e-11 A,3.1962e-11 A,0.0000e+00 A,0{11273}
OK
calib:source 5
OK
read:curr?
OK
1.0000e-04 S,-1.9413e-10 A,1.6103e-10 A,-9.6312e-11 A,3.1932e-11 A,8.3366e-08 A,-3.2017e-11 A,-3.1057e
-11 A,6.3973e-11 A,6.4903e-11 A,-3.2346e-11 A,9.6140e-11 A,9.5109e-11 A,3.2114e-11 A,0.0000e+00 A,3.19
66e-11 A,9.5992e-11 A{11914},9.7447e-11 A,1.6112e-10 A,-9.6634e-11 A,3.2119e-11 A,0.0000e+00 A,6.4574e
-11 A,-3.1941e-11 A,6.4192e-11 A,0.0000e+00 A,0.0000e+00 A,-3.2157e-11 A,6.4581e-11 A,0.0000e+00 A,0.0
000e+00 A,-9.5887e-11 A,2.5762e-10 A,0{11239}
OK

```

13 : Example puTTY session

12. Ensure nothing is connected to the signal inputs nor the external HV bias output. If your I3200 has the external bias HV option, type **conf:hivo:ext:volt 25<ctrl-J>**. This will turn on the high voltage at 100 V and the “HV on” LED will illuminate.
13. Type ***rst<CR>** to reset the I3200. The HV will disable and you will see the front panel LEDs going through the startup sequence. Your unit is functioning correctly and is ready to be integrated into your system.
14. If you wish to explore the ASCII communication capabilities of the I3200 more fully, refer to the commands list in section 24.

7 Using the PTC DiagnosticG1 Host Program

Usually you will use a custom application to communicate with the I3200, either one you write yourself using the software interfaces available from Pyramid Technical Consultants, Inc., or one that is supplied by Pyramid. However you can get started immediately using one of the PTC Diagnostic host programs. These are available for free download from www.ptcusa.com¹, and are provided with the I3200 for end-user customers. There are two generations of the Diagnostic software, and the I3200 is compatible with both.

PSI Diagnostic G1. This software supports all Pyramid products, apart from G2 devices. It allows you to connect the I3200 via an A500 controller and also directly via RS-232 and USB. Ethernet communications use UDP with an added reliability layer.

PTC Diagnostic G2. This software supports all G2 devices such as the A560, I128 and C400, plus a growing selection of other Pyramid devices, including the I3200. It allows you to connect the I3200 via an A360, A500 or A560 controller. Ethernet communications use TCP/IP and UDP.

Both Diagnostics are standalone Windows programs which allow you to set outputs and read, graph and log data from the I3200. Their user interfaces are similar. We shall start by looking at the PTC Diagnostic G1, which allows communication direct from the PC or via a loop controller. For some applications one of the Diagnostic programs may be adequate for all of your data acquisition needs. In any event it is useful to understand what you can do with the Diagnostic programs, because they expose all the functions of the devices they connect to. Application programmers will find this useful to help decide which functions to implement in their own host software.

7.1 Connecting the I3200 to the Host Computer

Connect up the I3200 in the way that is most convenient for you. The available methods are shown in figures 14 to 17. If you want to use the USB interface, you must first install the USB driver (see section 10). If you are using RS-232, set the mode switch to position 2 (115 kbps binary); if you are using USB, set it to position 1 (3 Mbps binary) and if you are using a loop controller, set it to position 0. The address switch can be set to anything between 1 and 15; the address is only used for fiber optic loop communications.

The PTC DiagnosticG1 supports all three connection methods. If you are using the PTC G2 Diagnostic, then can only connect through a loop controller.

1. <http://www.ptcusa.com/>

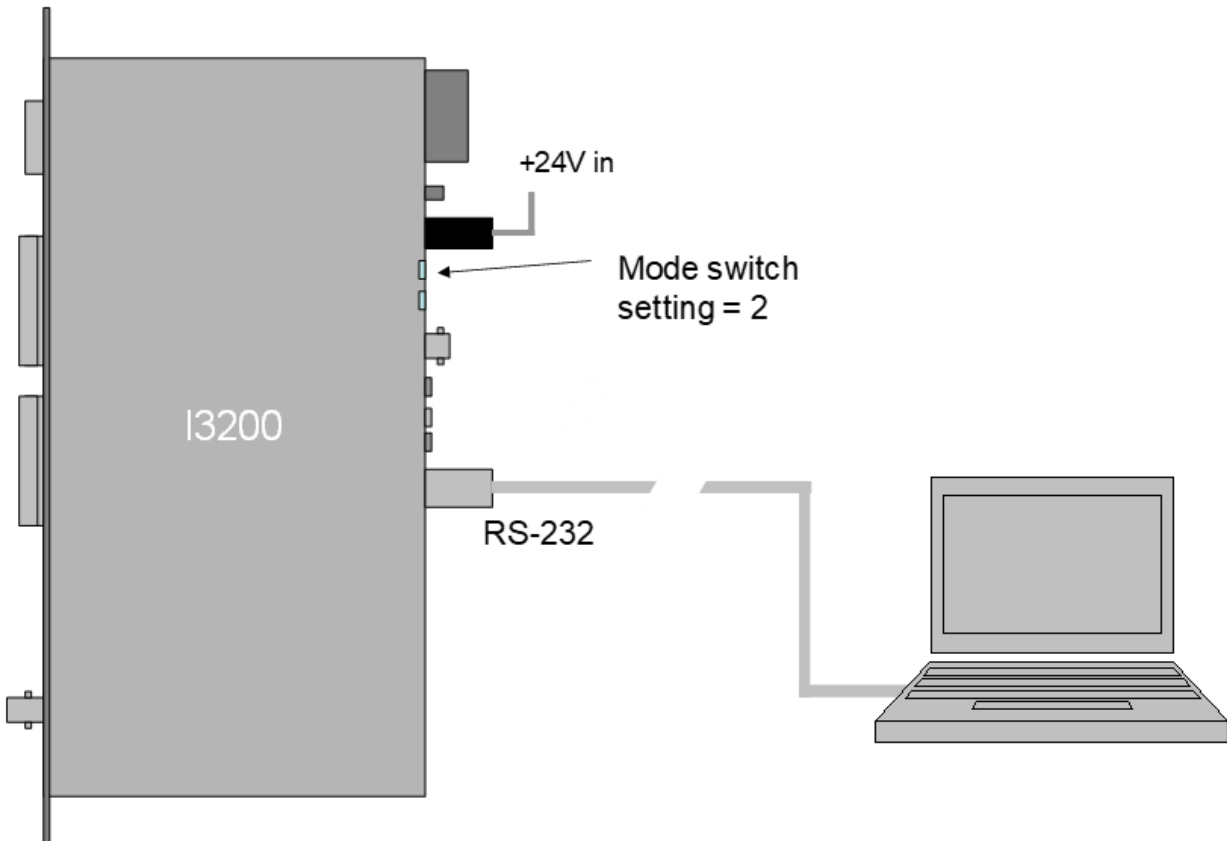

14 : Direct RS-232 connection to the I3200.

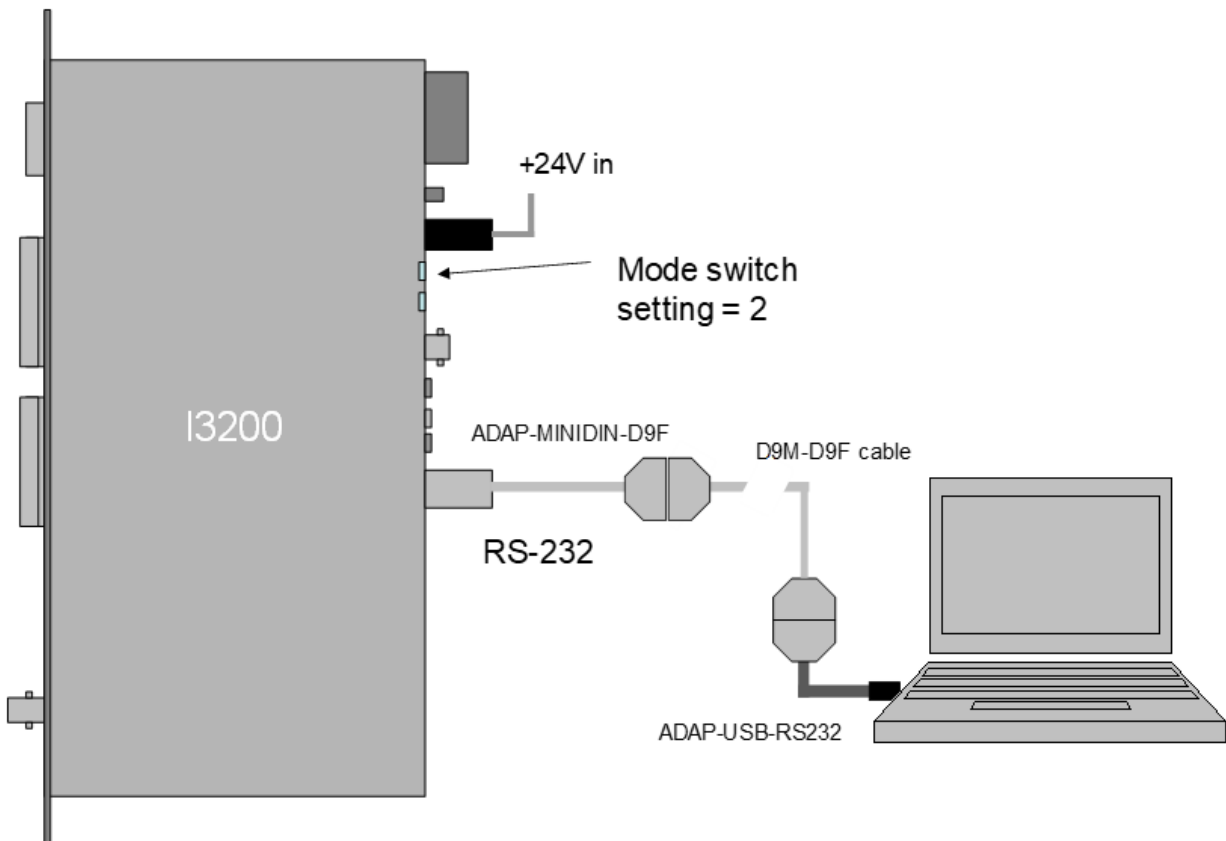

15 : RS-232 connection to the I3200 from a USB port using adaptors.

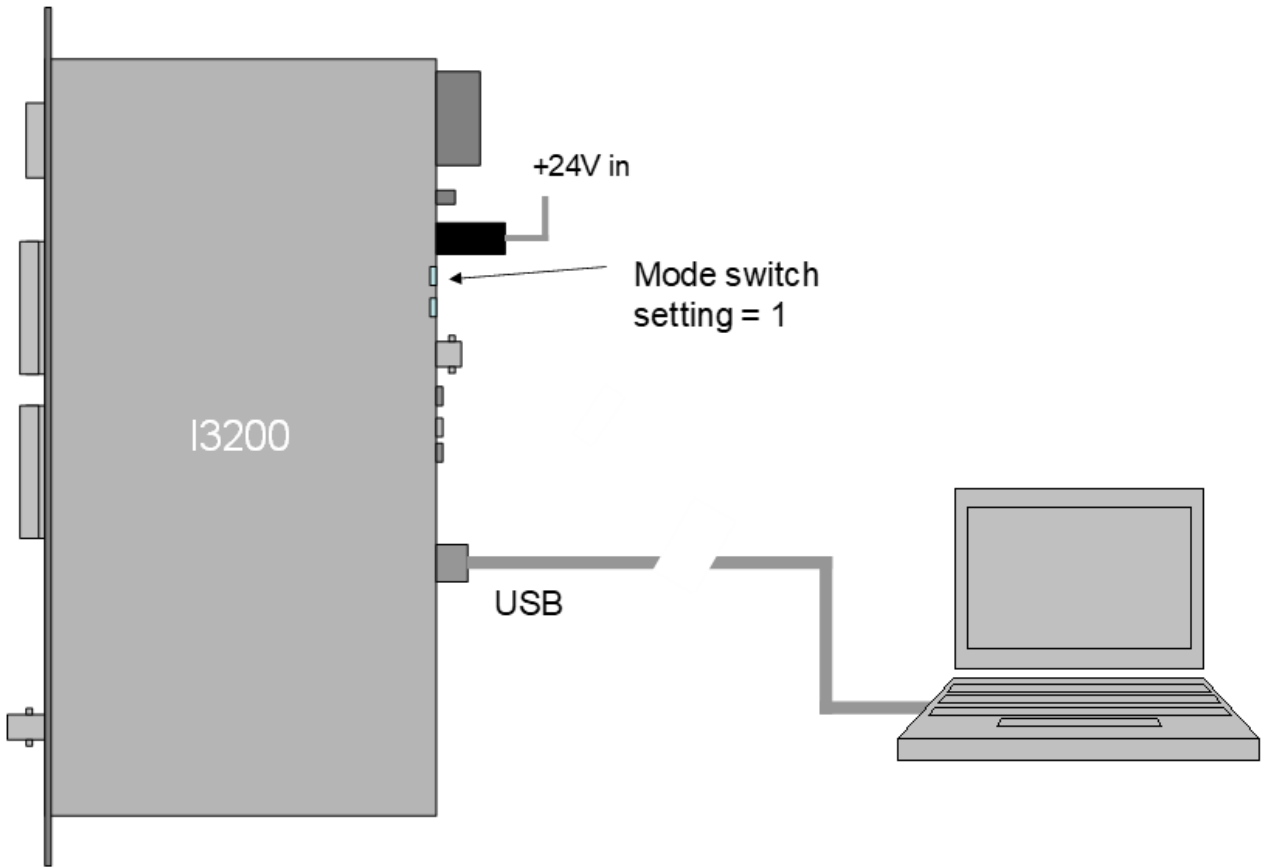

16 : Direct USB connection to the I3200.

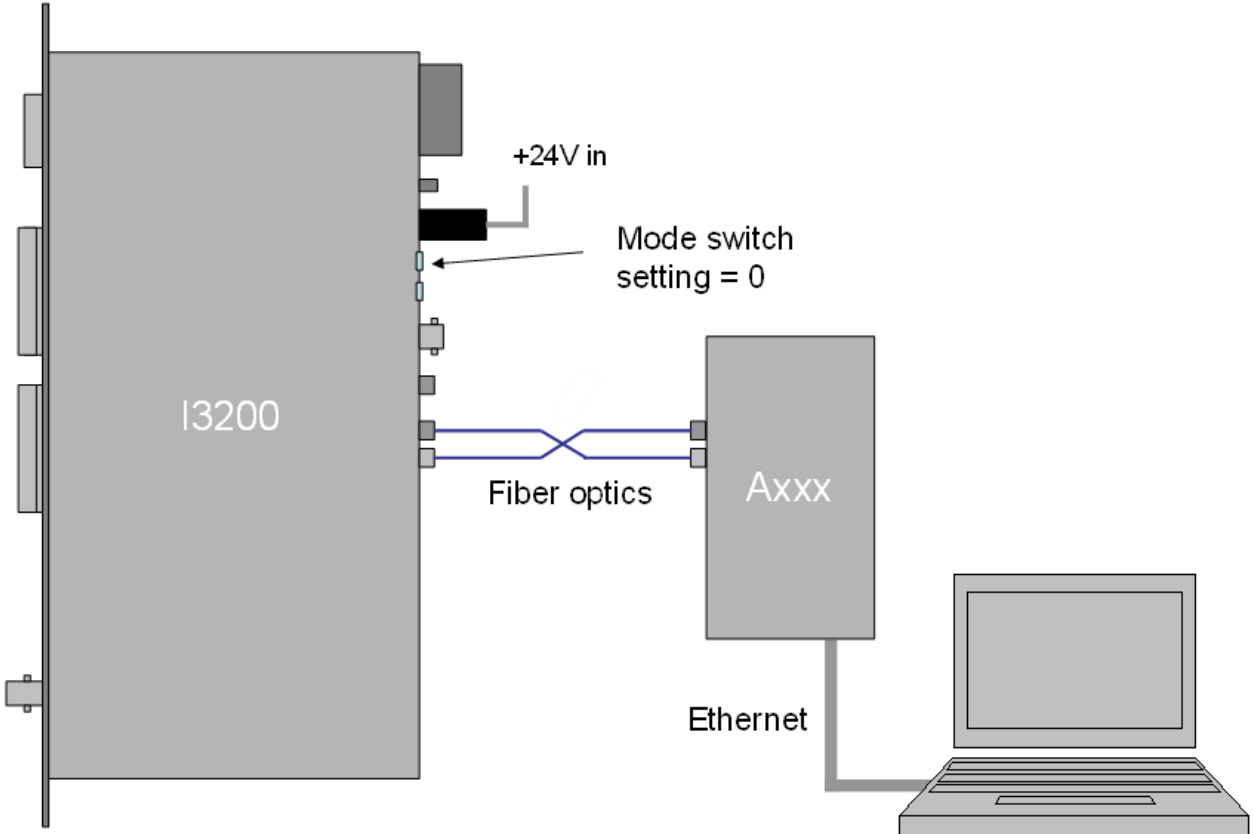

17 : Connection to the I3200 through a loop controller.

7.2 Installing and Using the PTC DiagnosticG1 Program

Download the PTC Diagnostic installer (.msi file) or find the copy on the USB memory stick if you purchased the I3200 as an end-user. We recommend that you copy the installer file into a directory on your host PC. Check the Pyramid Technical Consultants, Inc. web site at www.ptcusa.com² for the latest version.

The program runs under the Microsoft Windows operating system with the 4.0 .NET framework or later. Most new PCs have .NET already installed, or it can be downloaded from the Microsoft web site at no charge. The Pyramid installer will prompt you if you need to update the version on your computer.

Launch the installer and follow the screen prompts. Once the program has installed, you can run it at once. It will allow you to connect to the I3200 via its RS-232 or USB ports, or via Ethernet through an A500 controller. The Diagnostic uses the concepts of ports and loops to organize the connected devices. A port is a communications channel from your PC, such as a COM port, a USB port or Ethernet port. Depending on the setup, each port can be a channel to one or more loops, and each loop may contain up to 15 devices.

If you connect via USB or RS-232, the Diagnostic will see this simple configuration as a loop with just a single device on it. Because the direct RS-232 or USB connection does not allow other devices to be seen through that port, the I3200 appears as both a loop and a device on that loop. Contrast this to the situation where you have a loop controller, such as the Pyramid Technical Consultants, Inc. A360, A500 or A560 devices, and the I3200 is connected to the controller via a fiber-optic loop. In this case the loop controller is identified as the loop, and the I3200 as a device on the loop. We'll look at the case where the I3200 is connected via an A500 controller, and the A500 has IP address 192.168.100.213.

7.2.1 Discovering connected devices

Start the PSI Diagnostic. It will search the available ports and present a search a list. Figure 18 shows a case where the program found two serial ports, and a local area network adaptor with some previously entered IP addresses.

2. <http://www.ptcusa.com/>

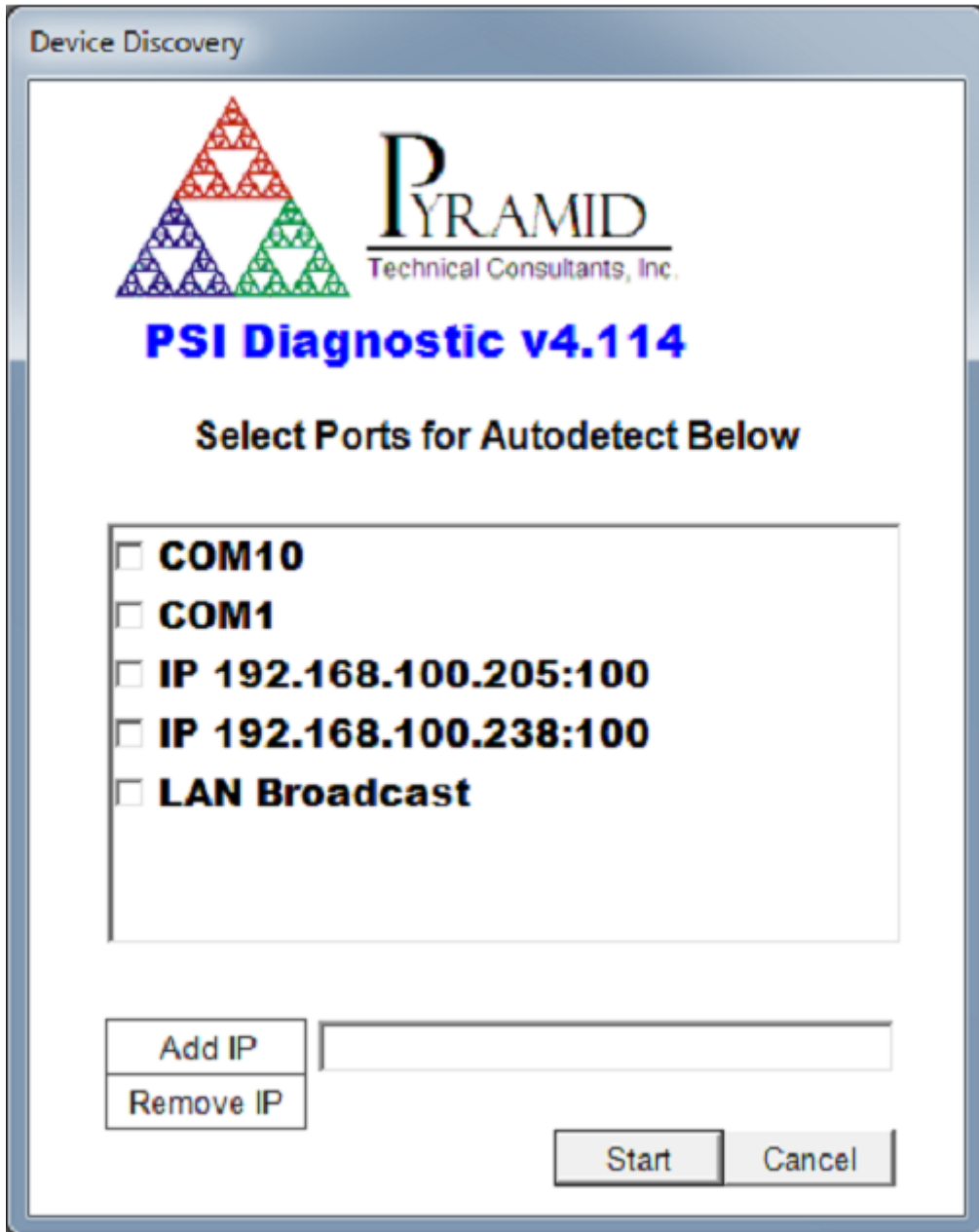

18 : PTC DiagnosticG1 Search Utility

To add the A500 address to the list, type in the IP address plus “:100” which is the port number that will be used by the Diagnostic. This will be added to the list when you click Add IP.

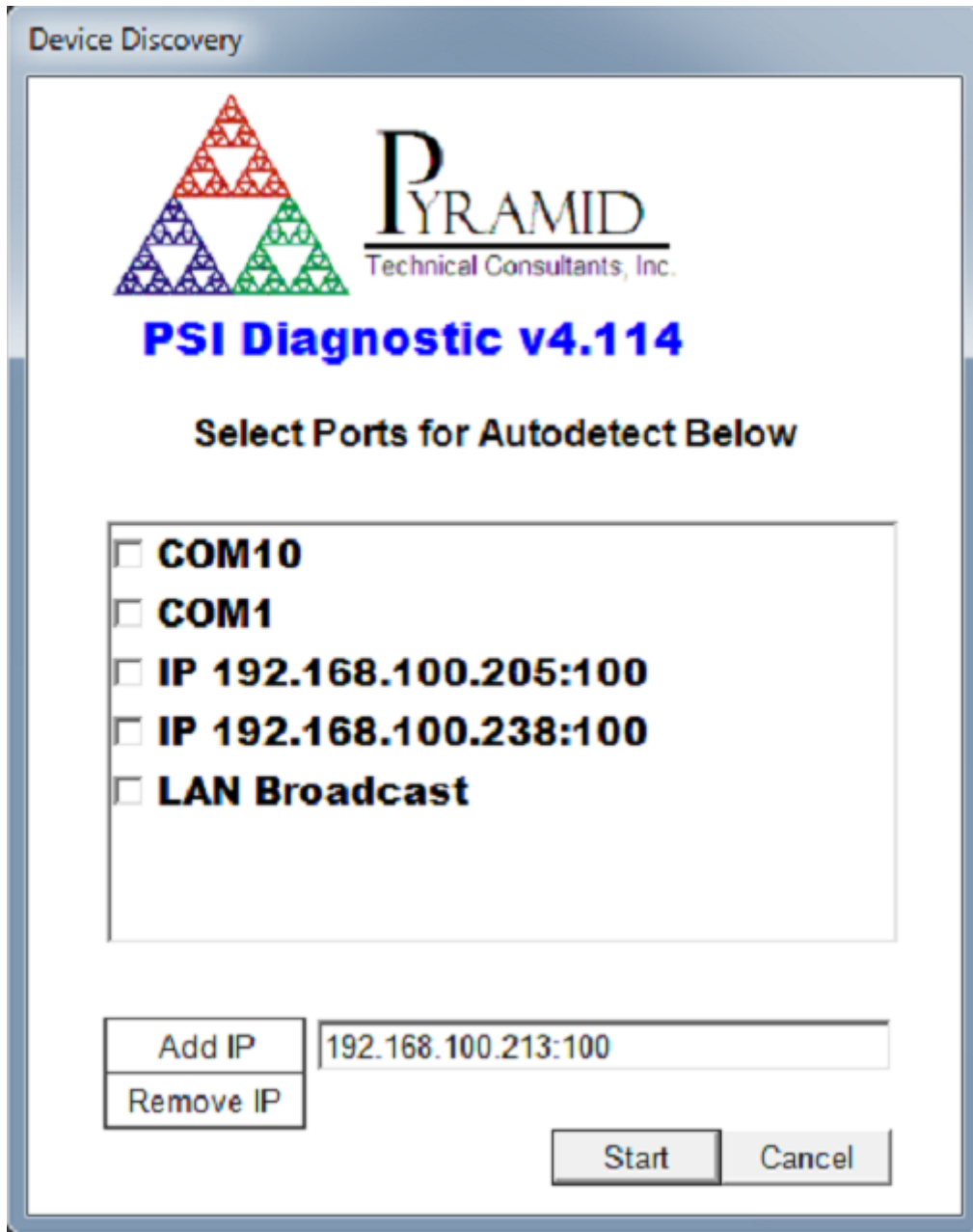

19 : Adding a new IP address

When you click Start, the program will search for loops and devices on all checked options in the list. A few seconds later, the program should find all the connected devices. In figure 20 we have found an I3200 with loop address 3, connected on loop 1 of an A500 controller at 192.168.100.213.

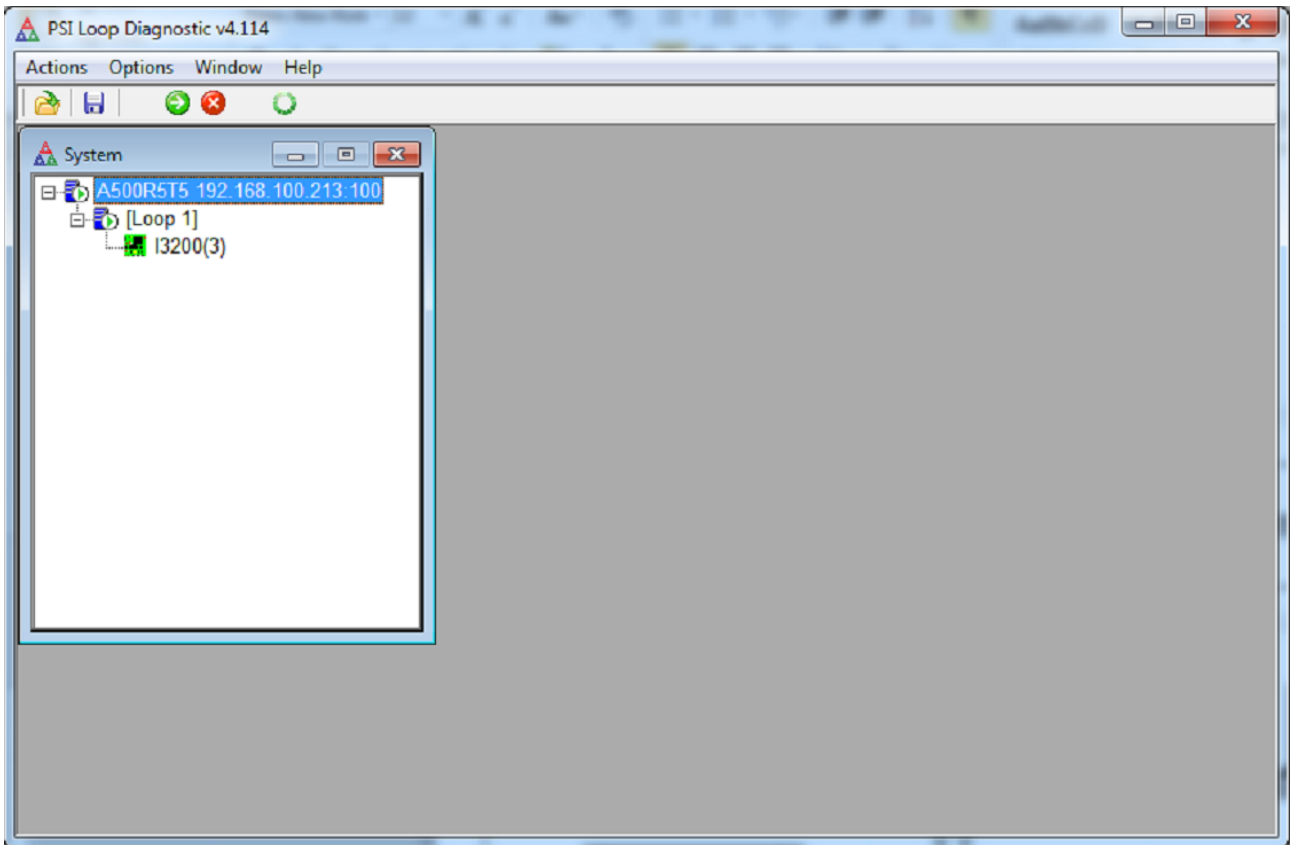

20 : Discovered device

7.2.2 Data tab

Clicking on the the I3200 entry in the explorer list will open the I3200 window after a few seconds. The data tab will be displayed, and the device will be acquiring data using default settings. If it is not acquiring data, click the “Initiate” button to start the acquisition. You should see autoscaled background noise values on the inputs, with a histogram display of the 32 channels. Use the strip chart control to switch to the alternative display of signal against time.

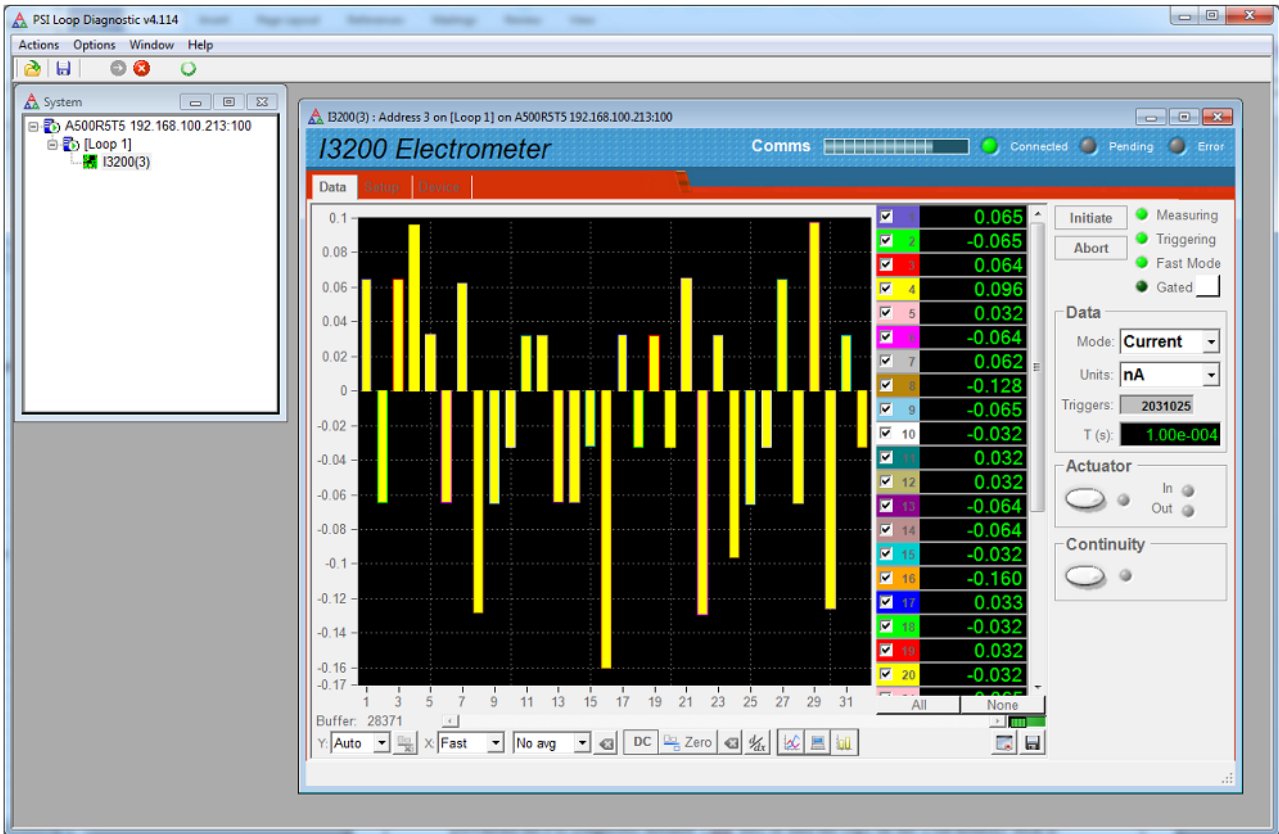



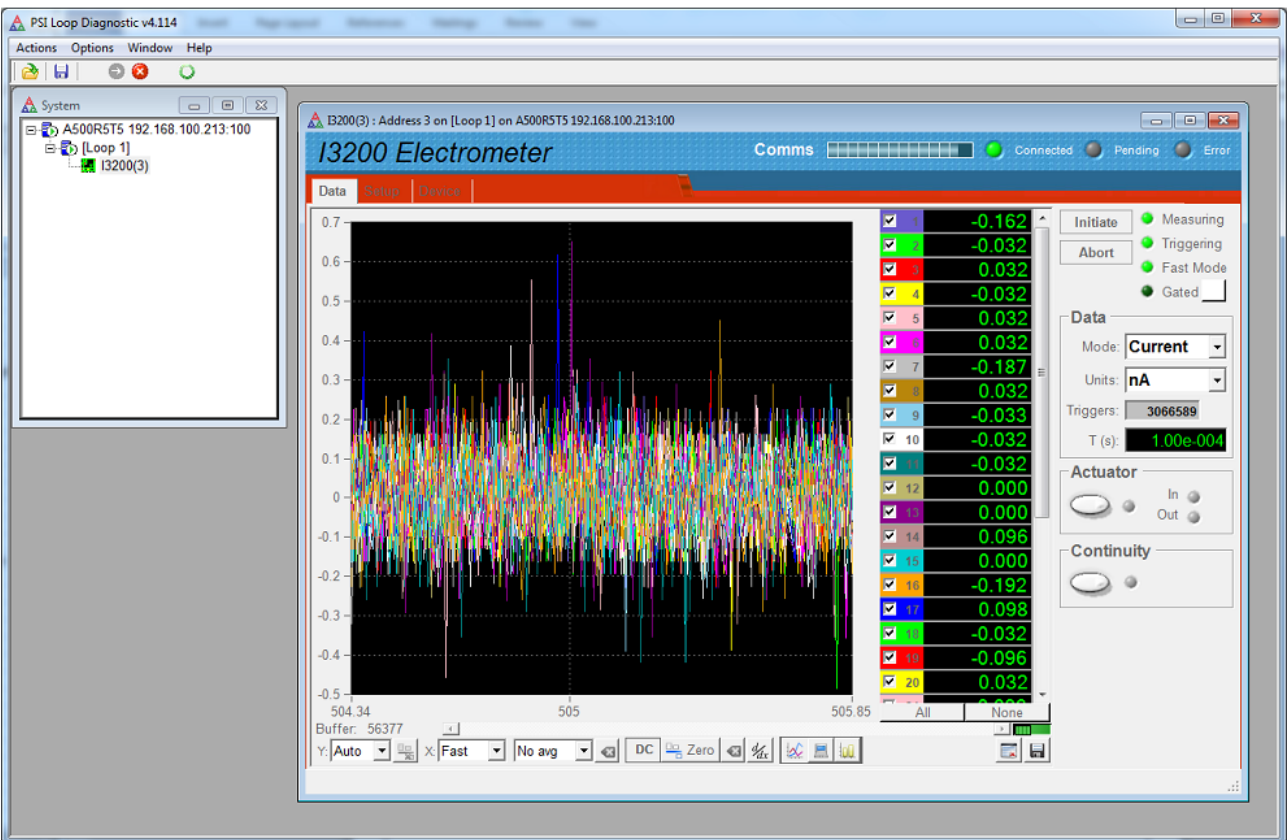



21 : I3200 data tab; histogram display.

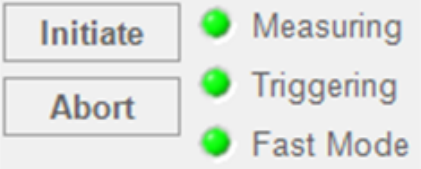
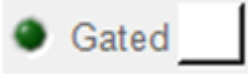

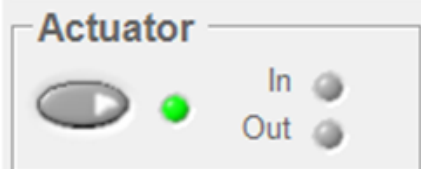
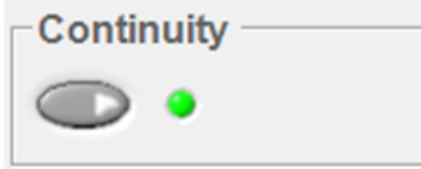
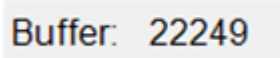

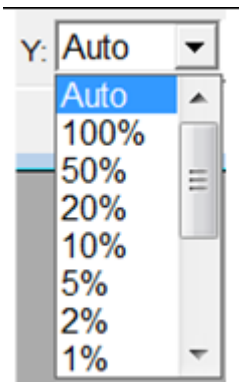

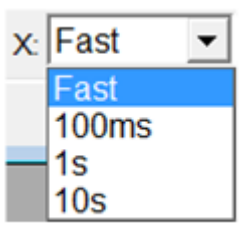
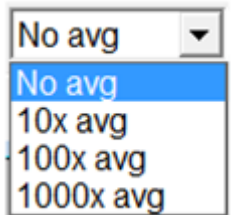
22 : I3200 data tab; strip chart display.

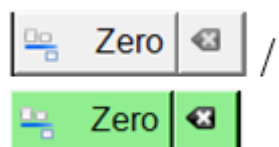
Now you can try the all the controls to see their effect.

<p>Initiate / Abort</p>  <p>The control panel for 'Initiate / Abort' features two buttons: 'Initiate' and 'Abort'. To the right of these buttons are three green LEDs labeled 'Measuring', 'Triggering', and 'Fast Mode'.</p>	<p>These buttons start and stop data acquisition. LEDs indicate whether the I3200 is measuring, triggered or streaming data to the controller in fast mode.</p>
<p>Gate active</p>  <p>The 'Gate active' control panel includes a green LED labeled 'Gated' and an unmarked button.</p>	<p>This LED lights if a gate signal is detected at either gate input. The unmarked button is a test utility that sends out a message trigger on the communication from the PSI Diagnostic to the I3200.</p>
<p>Triggers</p>  <p>The 'Triggers' control panel shows a digital display with the value '2031025'.</p>	<p>This counter shows the number of readings, each of 32 channels, made by the I3200 since the last initiate. The number of readings you can log on the host computer may be less, depending on the number of readings you request, the averaging period and the available data rate up to the loop controller and the host computer.</p>
<p>T (s)</p>	<p>This is a readback of the last used integration period, in seconds.</p>
<p>Actuator</p>  <p>The 'Actuator' control panel features a button, a green LED, and two small LEDs labeled 'In' and 'Out'.</p>	<p>Clicking on the button causes +24V to be put out on the actuator connector; this would typically be used to energize the solenoid of a pneumatic actuator. The adjacent LED turns green if the output is set on. The in and out LEDs show the state of the two limit switch sense inputs on the connector.</p>
<p>Continuity</p>  <p>The 'Continuity' control panel includes a button and a green LED.</p>	<p>This control causes +5V to be put out on particular pins of the actuator connector and the two signal connectors. It is intended for purposes such as external circuit continuity and isolation tests. CAUTION: Do not connect the +5V output directly to any of the signal inputs.</p>
<p>Buffer</p>  <p>The 'Buffer' control panel shows a digital display with the value '22249'.</p>	<p>The PSI Diagnostic collects data coming from the I3200 into a buffer, with a rate that is the lesser of the actual acquisition rate or the X axis rate setting. The buffer contents can be cleared with the Clr button, or can be written to a .csv file with the save button. The buffer number shows how much data is currently in the buffer. The maximum allowed is 65535 bytes, after which the buffer wraps around to overwrite the earliest values. You can toggle data plotting and accumulation into the buffer with the Run Plot control. When the accumulation is halted, then the slider is enabled, which allows you to scroll back through the data when in strip chart mode.</p>

<p>Y:</p> 	<p>This drop-down controls the vertical scaling of the data plot. You can select automatic scaling or various fixed proportions of the nominal 10 V full scale.</p>
<p>Display only positive values</p> 	<p>This control is enabled for fixed vertical scaling. It toggles the graphic from a display that is symmetric around 0 to one that shows only 10% of the selected vertical scale in the negative direction, and all of the selected vertical scale in the positive direction.</p>
<p>X:</p> 	<p>This drop down controls how fast new points are added to the data plot and the data log. For example, if your acquisition settings generate a value every 100 msec but you have 1 second selected on this control, then every tenth reading will be stored.</p>
<p>Filtering</p> 	<p>The PSI Diagnostic can apply a filter to the plotted data to allow you to pick small signals out of noise. This filter is independent of, and additional to, the effective averaging due to the I3200 integration period. The PSI Diagnostic filter is a simple IIR type, $Y_{plot_N} = Y_{new}/A + (1-1/A)Y_{plot_N-1}$, where Y_{new} is the latest reading, Y_{plot_N} is the current value to be plotted, Y_{plot_N-1} is the prior plotted value and A is the averaging value from the pull-down menu. You clear and restart the filter at any time by pressing the reset button. The filtering affects the graphed data and digital displays. If you choose to save the buffered data, you will have the opportunity to save the raw values or the filtered values.</p>
<p>DC/AC</p> 	<p>The DC/AC toggle removes the DC component from the strip chart or scope mode graphic data, but does not affect the digital display nor the logged data.</p>
<p>Zero correction</p> 	<p>When you press zero, the current values are captured and subtracted from all subsequent readings as displayed on all the graphic and digital displays, until you press the clear zeroes button. If you choose to save the buffered data, you will have the opportunity to save the raw values or the zero offset corrected values.</p>

<p>Differential display</p> 	<p>When this control is pressed, the graphic changes to display the difference between successive readings. The buffered data is not affected.</p>
<p>Graphic mode</p> 	<p>You can plot the data as a rolling strip chart or a bar chart (histogram). The scope mode is a variant of the strip chart. Instead of a rolling chart, the graphic is refreshed as a whole for each 256 samples. In histogram mode you can place a cursor on a particular channel to read out its value.</p>
<p>Clear buffered data</p> 	<p>Values are cleared from the PSI Diagnostic data buffer, but any acquisition in progress continues and timestamps are not reset.</p>
<p>Save data buffer contents to csv file.</p> 	<p>When you click this button, you will see a drop-down selection which allows you to save either the raw data, or the values with the PSI Diagnostic zero offset and averaging.</p>
<p>Prog Gain</p>	<p>This feature has been removed from the I3200 hardware. Make sure this value is always set to 1.</p>

7.2.3 Setup tab

Click on the “Setup” tab. Here you can adjust measurement parameters such as integration period, feedback capacitor and PGA setting, set the external bias high voltage supply, and use the built-in calibration facility.

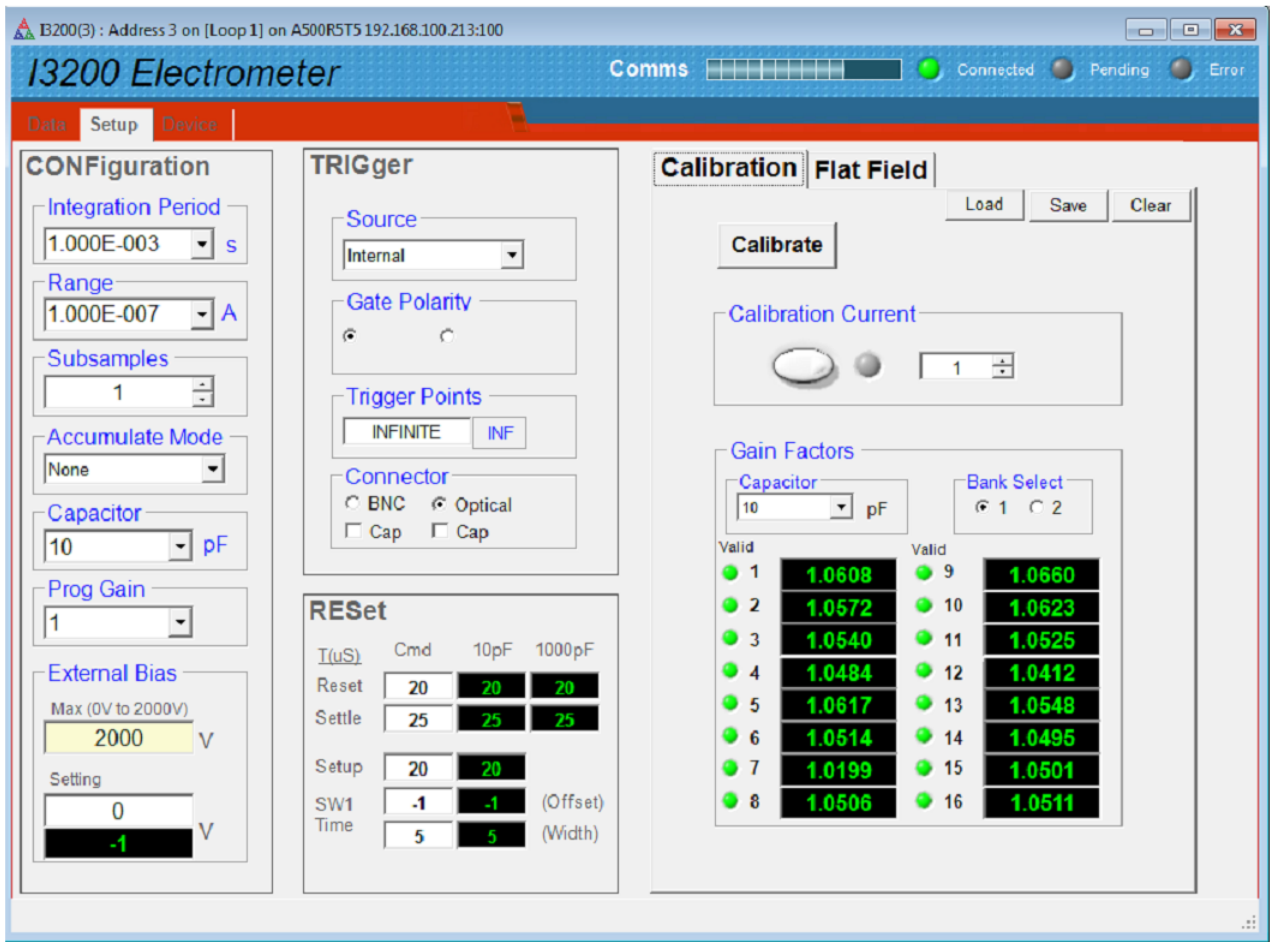

23 : Setup tab

Try the following test to become more familiar with the I3200:

Click the “Calibrate” button and confirm that you wish to continue with the update when the warning dialog appears. After a about a minute you should see the gain factors updated (they shouldn’t change much). You can see the full set of factors by selecting the second bank of 16 channels and the other feedback capacitor.

Now click the calibration current button and select a channel. If you return to the data tab and click initiate, you should see the calibration current on that channel. Try moving it to other channels. If the calibration current is overrange (current reading is shown in red text), reduce the integration period to bring it into range.

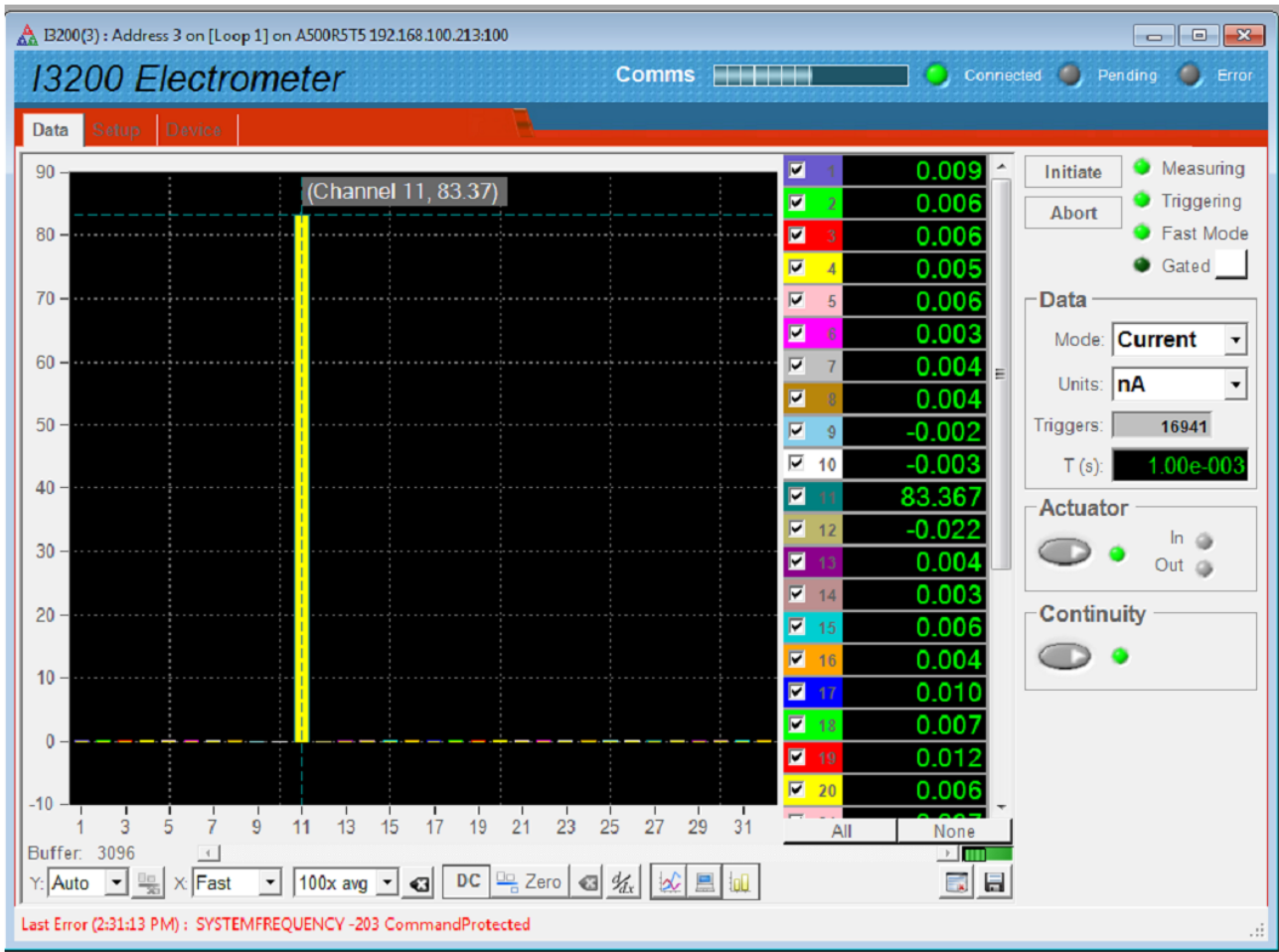

24 : Calibration current directed to channel 11.

The full set of controls and readbacks on the setup tab are as follows:

<p>Integration period</p> <p>Integration Period</p> <p>1.000E-003 s</p>	<p>This dropdown selects the integration period used by the I3200, in seconds. You can enter values other than the ones in the drop down by entering them directly. The program shows the resulting approximate full scale current for that integration period and selected feedback capacitor in the Range box.</p>
<p>Range</p> <p>Range</p> <p>1.000E-007 A</p>	<p>Instead of entering the integration period, you can select the range in amps, and the program will compute the corresponding period.</p>
<p>Subsamples</p> <p>Subsamples</p> <p>1</p>	<p>The number of subsamples per integration. See sections 13 and 15 for full details about this feature.</p>

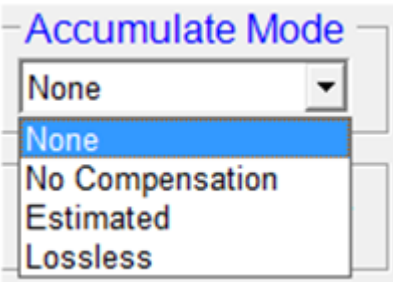
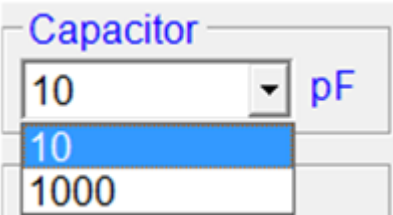
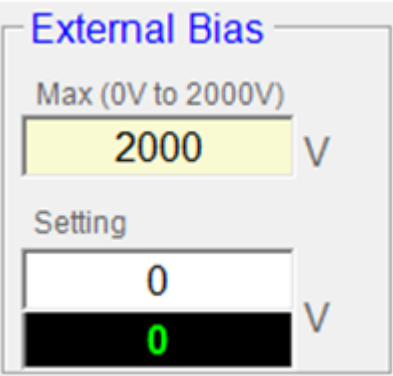
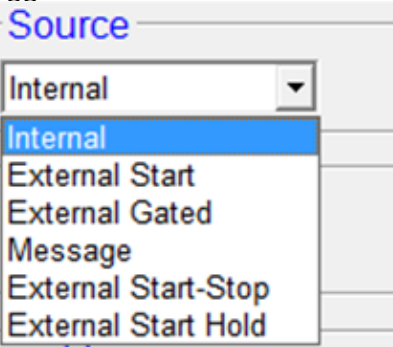
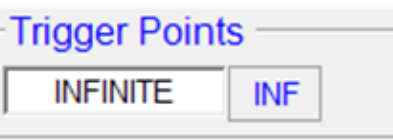
<p>Accumulate mode</p>  <p>The screenshot shows a dropdown menu titled "Accumulate Mode". The current selection is "None". The menu is open, showing the following options: "None", "No Compensation", "Estimated", and "Lossless".</p>	<p>Selection of various modes which integrate the charge since the last initiate, across multiple integrations. See section 15 for more details.</p>
<p>Capacitor</p>  <p>The screenshot shows a dropdown menu titled "Capacitor". The current selection is "10". The menu is open, showing the following options: "10" and "1000". The unit "pF" is displayed to the right of the dropdown.</p>	<p>Select which of the two feedback capacitors to use. The selection applies to all channels.</p>
<p>External Bias</p>  <p>The screenshot shows the "External Bias" control panel. It features a "Max (0V to 2000V)" section with a yellow highlighted box containing the value "2000" and a "V" unit. Below it is a "Setting" section with a black highlighted box containing the value "0" and a "V" unit.</p>	<p>If your I3200 has the high voltage option, you will see the range of the installed HV module displayed ("Max (0V to xxxxV)". You can set the output voltage with the Setting box. The supply turns on as soon as you enter a non-zero value. If the supply is negative polarity, you must enter the negative value explicitly. The Max box allows you to constrain the settings to a particular maximum, for example to protect sensitive equipment that cannot sustain the maximum voltage of the supply. Note however that there is some overshoot at turn on if your set point is only a small fraction of the full range of the supply. You should choose a range suited to your application.</p>
<p>Trigger:Source</p>  <p>The screenshot shows a dropdown menu titled "Source". The current selection is "Internal". The menu is open, showing the following options: "Internal", "External Start", "External Gated", "Message", "External Start-Stop", and "External Start Hold".</p>	<p>You can set various trigger options. "Internal" setting allows the I3200 to "free run" and take data without the need for incoming synchronization signals. Full details of trigger modes are given in section 15.</p>
<p>Trigger points</p>  <p>The screenshot shows the "Trigger Points" control panel. It features two buttons: "INFINITE" and "INF".</p>	<p>This parameter selects how many readings will be taken following initiation and triggering, up to a maximum of 65535. Clicking the INF button invokes the "Infinite" setting, which allows the I3200 to acquire data continuously, until you abort or alter settings.</p>

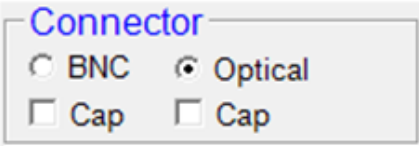
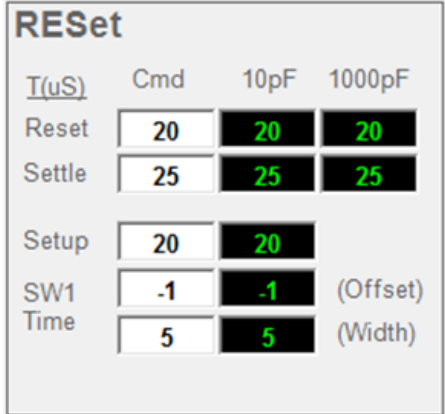
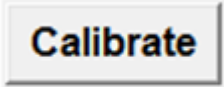
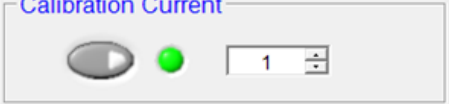

<p>Connector</p> 	<p>Select which connector (BNC or optical receiver) the I3200 should look on for the external gate trigger signal. You can also select which connector the I3200 should look on for the real-time capacitor switching signal. The Cap check access the dynamic capacitor switching feature (see section 15). Checking the Cap box under the gate input that you are <u>not</u> using for acquisition triggering causes the I3200 to look at the level on the second gate input to decide which feedback capacitor to use.</p>
<p>Reset</p> 	<p>These controls set the integrator reset timing parameters. See section 15. For most purposes you can use the default settings.</p>
<p>Calibrate</p> 	<p>Clicking the calibrate button causes the I3200 to execute its automatic self-calibration routine. A dialog box will open warning that you are about to overwrite the stored calibration values. The gain values will be displayed upon completion. Click the bank selection options to display the gains for channels 1-16 (bank1) or 17-32 (bank 2), and the capacitor select dropdown to choose which capacitor's gains to display. The gains displayed are those for the selected capacitor. You can save the calibration to I3200 EEPROM memory, load a previously stored calibration, or clear to the uncalibrated state.</p>
<p>Calibration Current</p> 	<p>You can enable the built-in calibration source with this button, and control which channel it is directed to. The current is 500 nA (rev 2 and earlier hardware) or 83.3 nA (rev 3 hardware).</p>
<p>Flat Field</p>	<p>The Flat Field facility of the PSI Diagnostic allows you to compensate for unequal responses from the readouts of a multi-element sensor system, such that the response to uniform irradiation is uniform. This is described in more detail in section 15.</p>

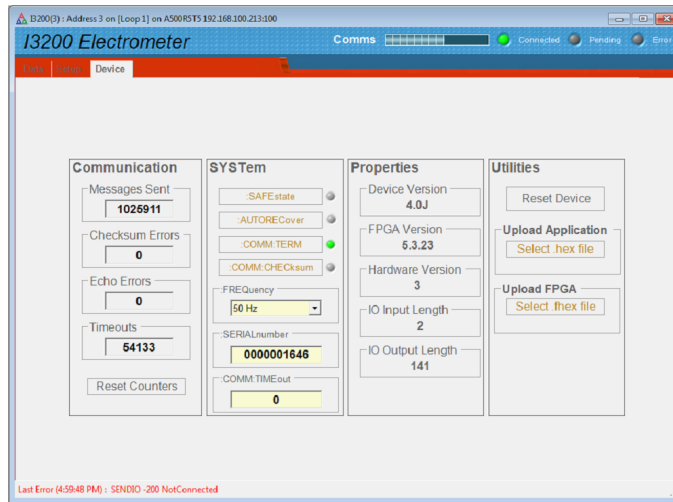

7.2.4 Device tab

The Device tab allows you to check the communication link status and verify the versions of the hardware and firmware. On the right is the firmware update utility. You can use this to download firmware updates (.hex and .fhex files) downloaded from the Pyramid Technical Consultants, Inc. web site.

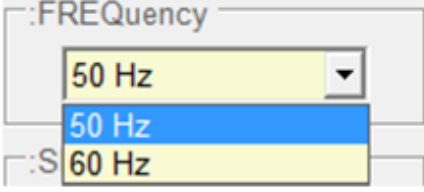
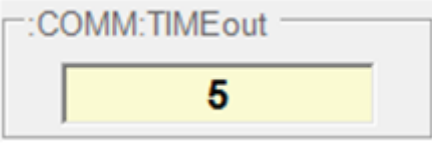

25 : Device tab showing firmware update utility controls on the right.

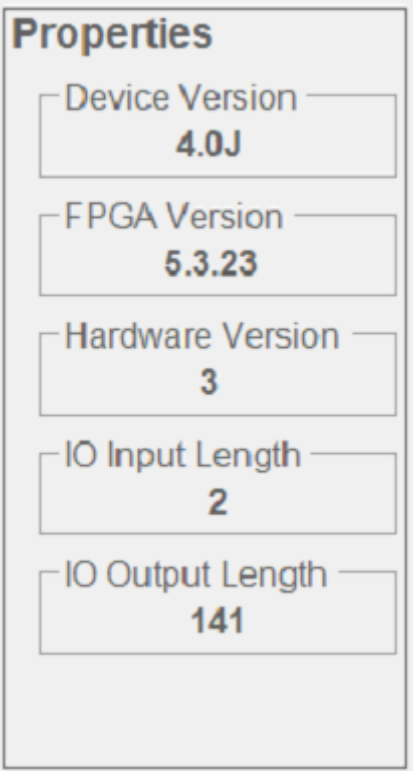
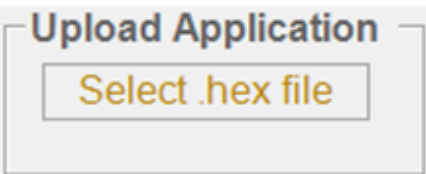
<p>Communication</p>	<p>The counters show details of the communications between the I3200 and its host. You can click the Reset Counters button to reset the fields to zero.</p>
<p>SAFESate</p> 	<p>Enabling SafeState will cause the I3200 to go to its defined safe state if there is a communications timeout. In particular the HV supply will be turned off.</p>
<p>AUTOREcover</p> 	<p>Enabling :AUTOREcover sets a state in which the I3200 will attempt to restart automatically if it detects data corruption.</p>
<p>Comm:Term, Comm:Checksum</p>	<p>These controls affect behavior of the I3200 when in ASCII terminal mode. You can ignore them when using the PSI Diagnostic.</p>
<p>Frequency</p> 	<p>This parameter sets the averaging period that will be used for the automatic calibration. You should set it to the local line frequency.</p>
<p>SerialNumber</p>	<p>This is the manufacturing serial number of your device, and should be left unchanged.</p>
<p>Comm:Timeout</p> 	<p>This field can be used to control how the I3200 behaves if the communication link to its host is lost. Entering any non-zero integer value sets the number of seconds before the I3200 goes to the defined safe state, if the SAFESate feature is enabled.</p>

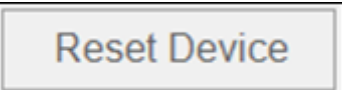
<p>Properties</p> 	<p>This box displays: PIC microcontroller firmware version. FPGA firmware version. Board hardware version. Some details of the I/O messaging are also displayed.</p>
<p>Upload Application</p> 	<p>This button starts the I3200 PIC microcontroller firmware update process. It opens a file selection dialog. When you select a hex file it will start uploading to the I3200 immediately. Upon completion the I3200 will restart automatically, and you will see the new Device Version number displayed. See section 26 for full details of the process.</p>
<p>Upload FPGA</p> 	<p>This button starts the I3200 FPGA firmware update process. It opens a file selection dialog. When you select a fhex file it will start uploading to the I3200 immediately. Upon completion you will be prompted to power cycle the I3200 to load the new code, and you will see the new Device Version number displayed. See section 26 for full details of the process.</p>
<p>Reset</p> 	<p>CAUTION: This button causes a full warm reset of the I3200. Any acquisition in progress will be lost, the HV will be disabled and the I3200 will return to its default settings.</p>

8 USB Installation

If you intend to use the USB interface, you must install the appropriate drivers on your computer. The I3200 is supplied with all the necessary USB drivers, support files and utility programs on a USB memory stick. We recommend you copy these into a directory on your computer. The USB interface is accessible via the PTC DiagnosticG1 software.

Each I3200 is identified on USB by a vendor identification (VID), a product identification (PID) and the unit serial number. All I3200s have the same VID (0403, indicating the USB interface chip vendor, FTDI Ltd) and PID (C58A, indicating the I3200 product) but have a unique serial number, which is prefixed by the PID.

Microsoft Windows will recognize when a device with a new combination is connected for the first time, and launch the “Found New Hardware” wizard. The selection of files installed by the Wizard is guided by information in the file PTC.INF. There are two types of driver for the FTDI chip, COM and DLL. It is important not to let the wizard install the COM driver, which it tends to do if you take defaults. The PSI Diagnostic software requires the DLL driver. The wizard should be run as follows for Windows XP. If you later connect a different I3200 via USB, you will be prompted to go through the installation again. This is because Windows XP distinguishes devices that have different serial numbers, even if they are otherwise identical.

The driver installation is similar but more automated in Windows 7. Windows 7 and Windows 10 are also able to tell that different I3200s can use the same driver. If you have a 64-bit computer, you will need to visit the FTDI website to find the most recent drivers (<https://www.ftdichip.com/Drivers/D2XX.htm>).

1. Don't let the wizard look for drivers on the internet.

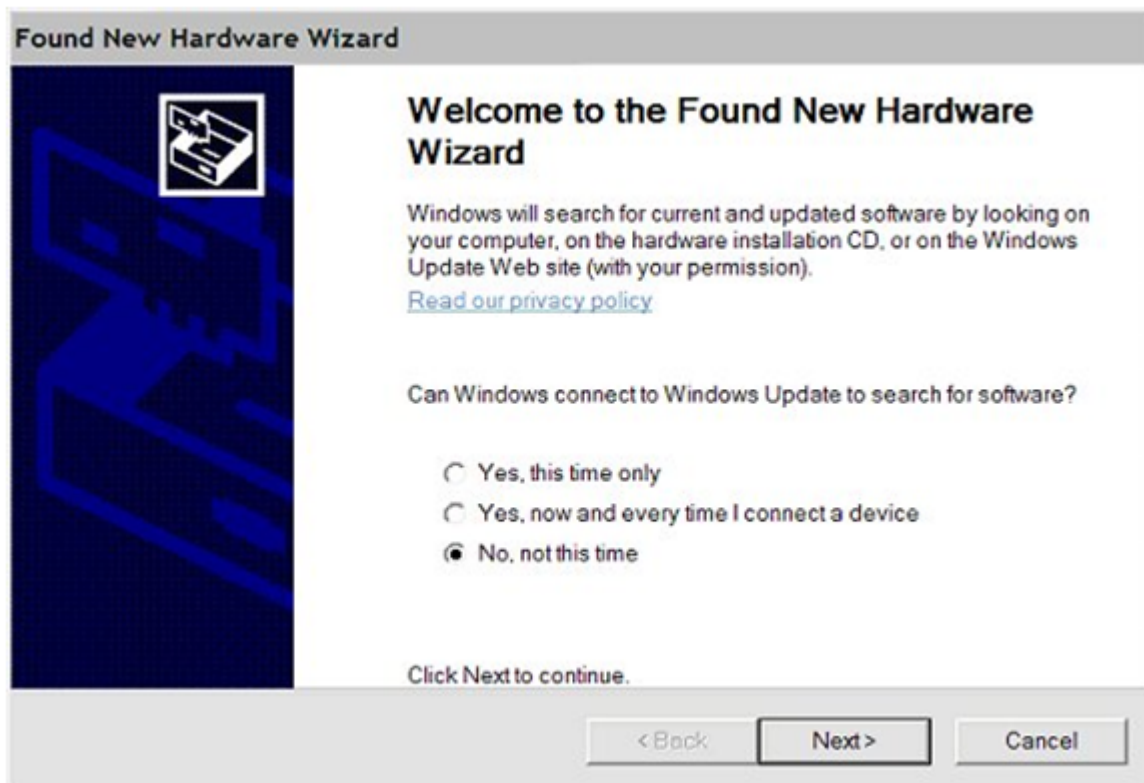

26 : Start of USB installation wizard

2. Select installation from a specific location.

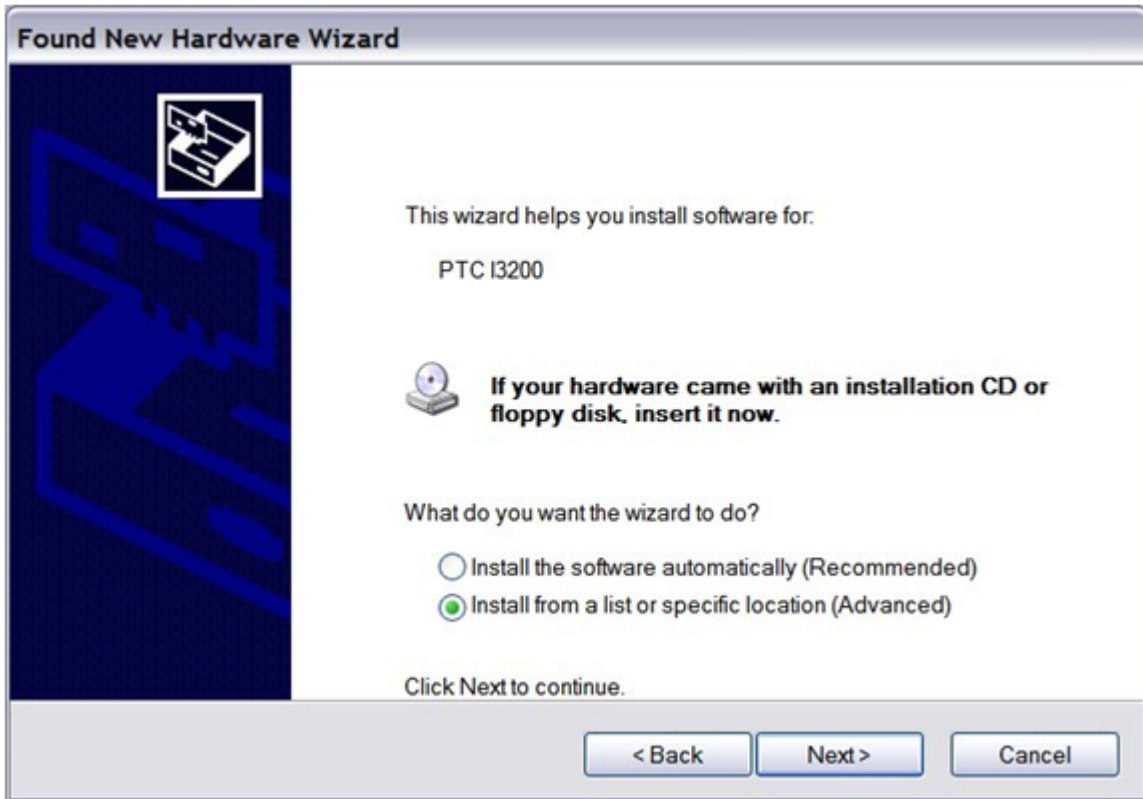

27 : Selecting installation from a specific location

- Using the browse option, navigate to the location of the PTC.INF file in the directory where you copied it on your computer. The driver files and uninstall files should be in the same directory as PTC.INF.

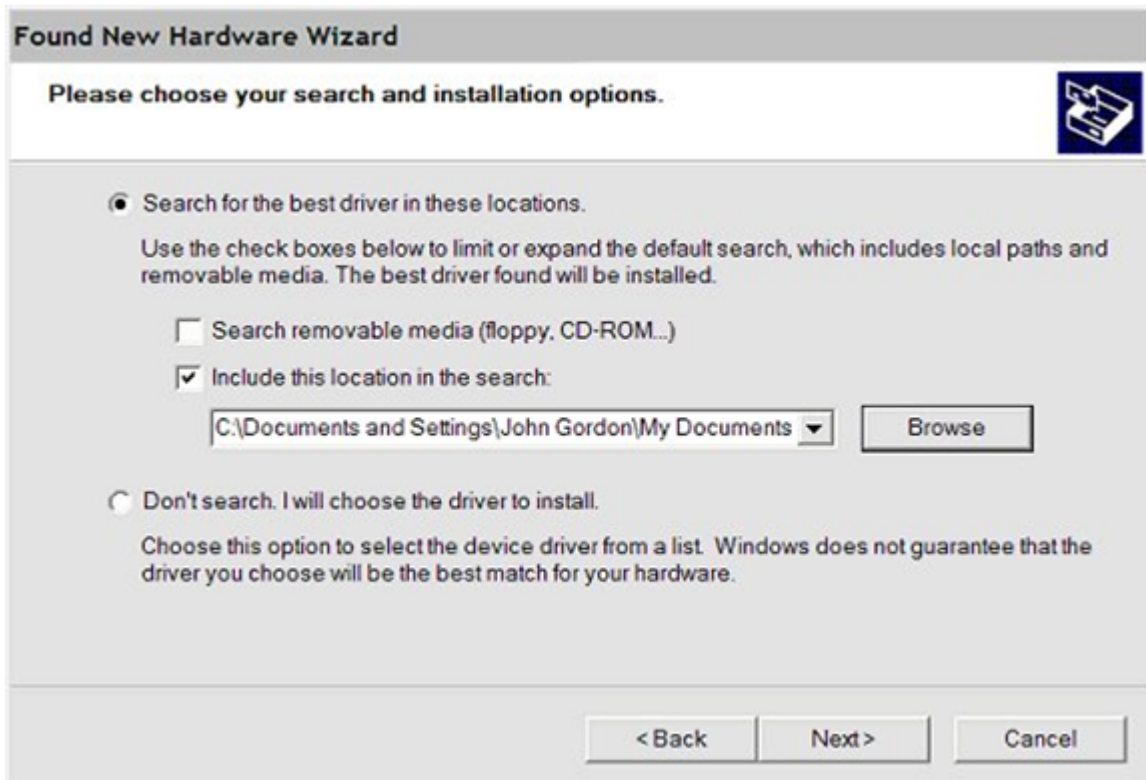

28 : . Preparing to browse to the directory where the PTC.inf file has been placed

The wizard may find other .inf files which also have valid entries, depending on the history of your PC. Select the PTC.INF file to be sure you have the latest version.

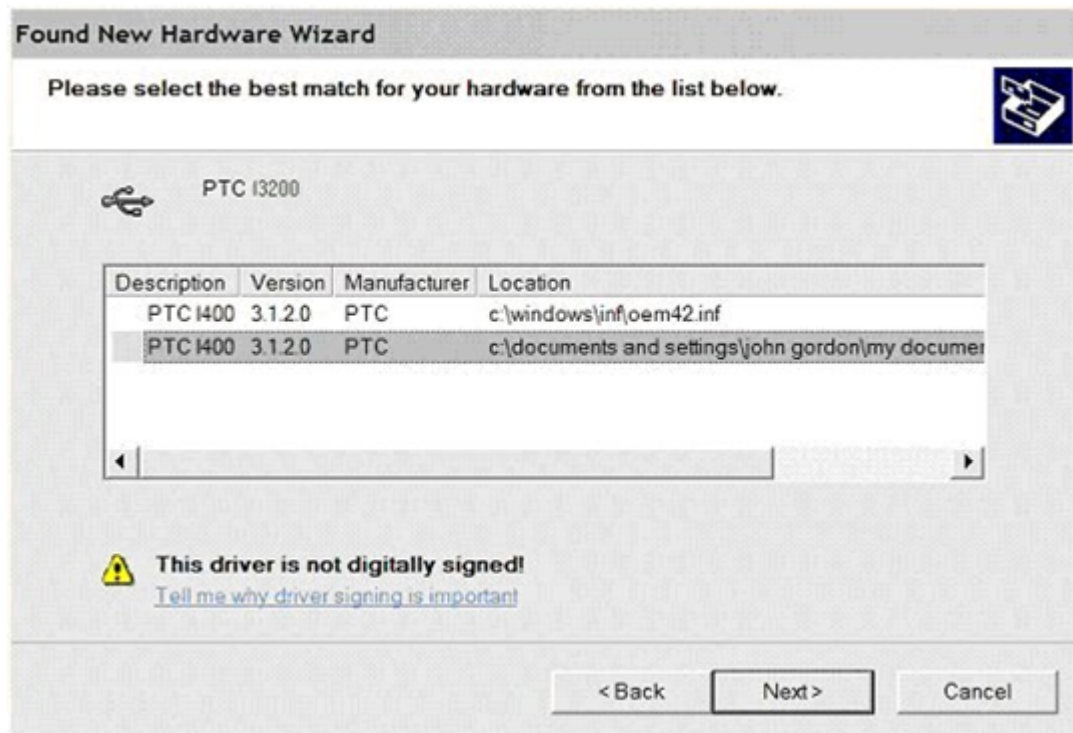

29 : Selecting the PTC.inf file

If there is only one valid entry, the wizard will proceed directly to the installation phase.

4. Allow the installation to continue despite the driver not having the Windows Logo approval.



30 : Ignoring the Windows Logo testing warning

5. The driver installation should now occur.

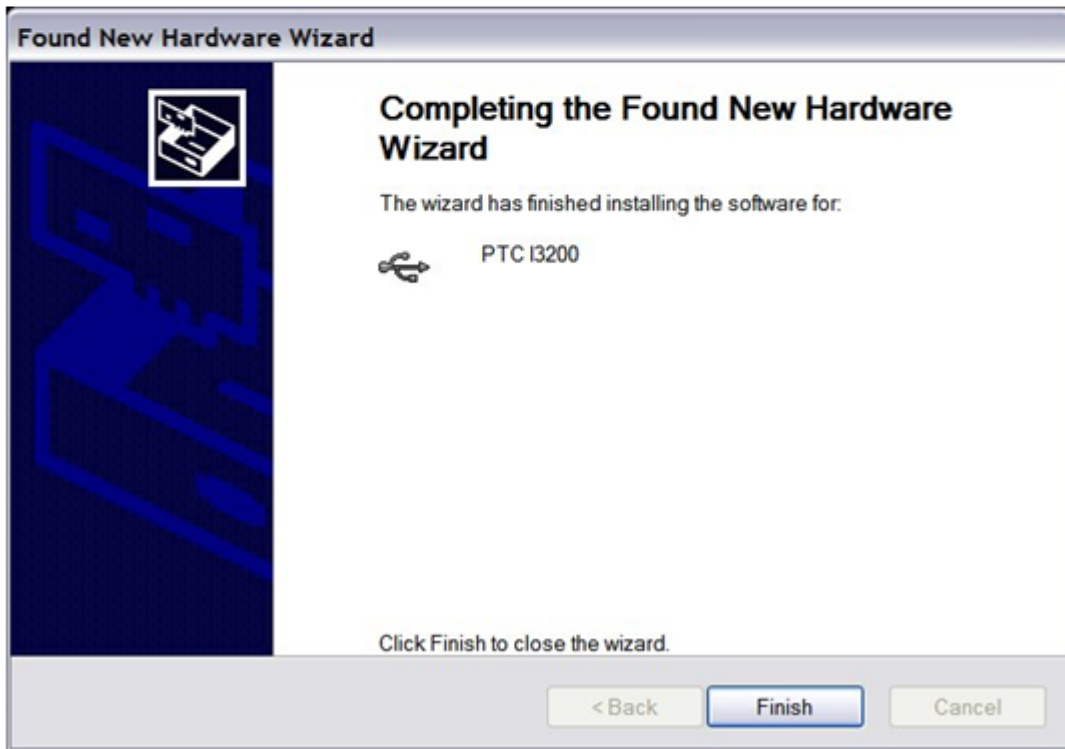
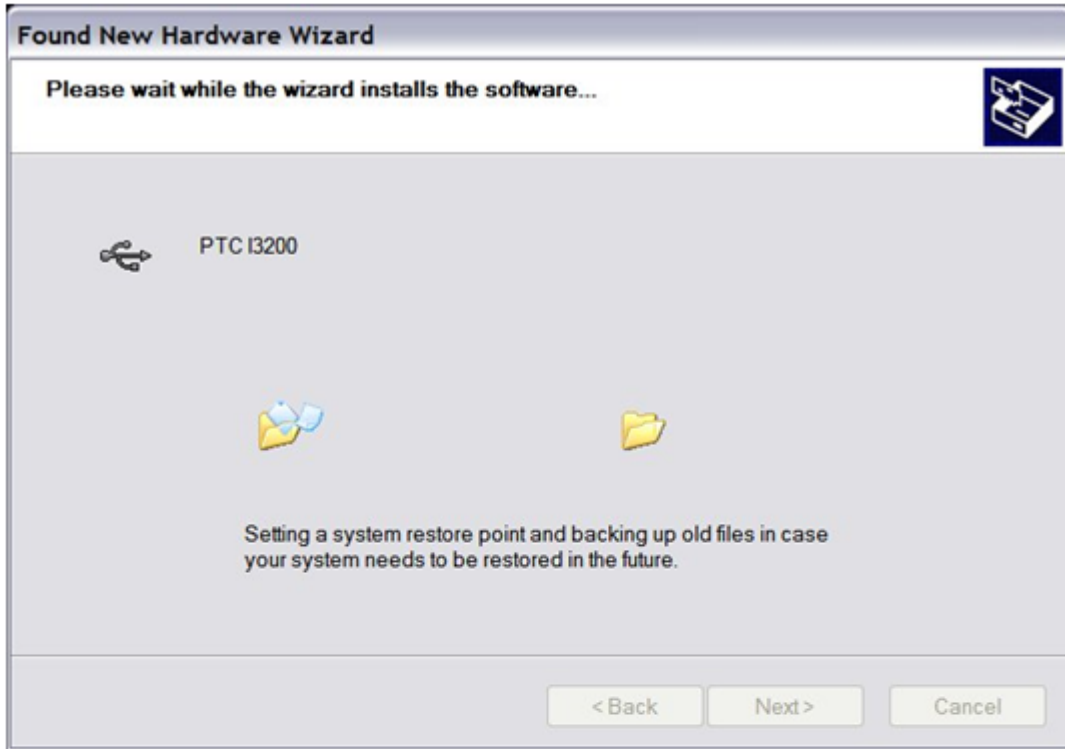

31 : Driver installation dialogs

When installation is complete the “Your new hardware is installed and ready to use” message balloon should appear. You may be prompted to reboot your PC.

9 Choosing ASCII or Binary Modes

The communication mode that you choose is guided by your application requirements, and your host computer system. Some of the features and operations described elsewhere in this manual are restricted to one or other of the modes. The example screenshots from the PTC Diagnostic host program show the I3200 working in binary mode.

The key features of the two modes are as follows:

ASCII mode

- Optimized for ease of use with existing and legacy software systems
- SCPI instrument model
- Control is possible from basic terminal programs and ASCII serial device drivers
- The calibration is applied in the I3200 and results are transmitted as floating point numbers in amperes or coulombs and seconds
- Maximum data rate to host 3 Mbps (if physical layer allows), or more typically 115.2 kbps for RS-232 connections
- Supports looped devices

Binary Mode

- Optimized for speed
- Maximum data rate to host 10 Mbps
- Supports looped devices
- Requires the A500 real-time loop controller and PTC DiagnosticG1 software.
- Control requires a suitable DLL to run on the host computer, integrated with your application code, or the PTC Diagnostic host program
- Complete data sets can be buffered in the I3200 internal memory for cases where acquisition rates exceed the maximum data transfer rate
- All data is stored and transferred as 16 bit binary. Conversion to values in coulombs or amps is performed by the device receiving the data (PC host or the Pyramid Technical Consultants, Inc. loop controller), using calibration factors uploaded from the I3200.
- Required for the I3200 FastMode, which guarantees contiguous data at maximum rate in short bursts irrespective of the data rate to the host, by local buffering in the I3200. FastMode also allows integration periods and subsample periods down to 20 μ sec.

10 Using the PTC DiagnosticG2 Host Program

The PTC DiagnosticG2 program has a very similar interface to the DiagnosticG1. It is better suited to large scale systems and provides the following advantages relative to the DiagnosticG1.

Allows the use of all loop controllers (A360, A560, A500, F460, I128, C400, I6400)

Common software structure to the IG2 channel access server which provides a connection to the EPICS data distribution system (<https://epics.anl.gov/>).

Linux version is available (enquire with Pyramid Technical Consultants, and have details of your Linux distribution ready).

Unlike the DiagnosticG1, PTC DiagnosticG2 does not support direct RS-232 or USB connection to the I3200.

10.1 Installing the PTC Diagnostic G2

The Windows installation runs from an msi installer. The file is available for downloads from the Pyramid website, or can be found on the USB stick supplied with the I3200. With Windows 10 you may be asked to allow the installer to run. Select “More info” and then click Run anyway. Follow the prompts to complete the installation. If you are replacing an older version, we recommend you uninstall that first.

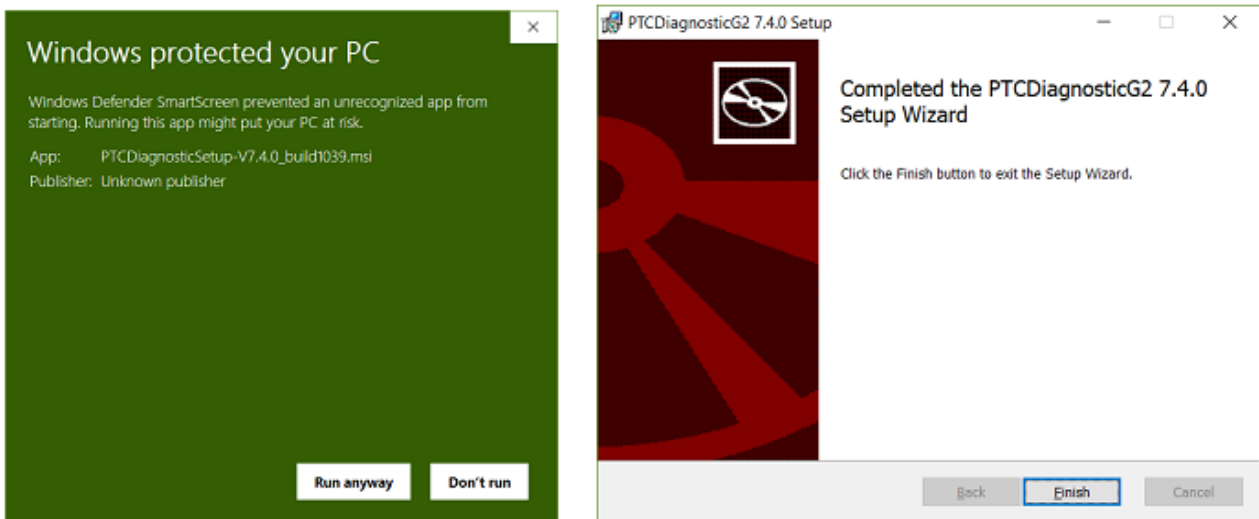

32 : PTC DiagnosticG2 installation

10.2 Running the PTC Diagnostic G2

10.2.1 Discovering devices

When you start the program it shows the Discover Devices pop-up. Any previously discovered loop controllers will be shown in the list. Click Discover Controllers to search the available network for Pyramid loop controllers.

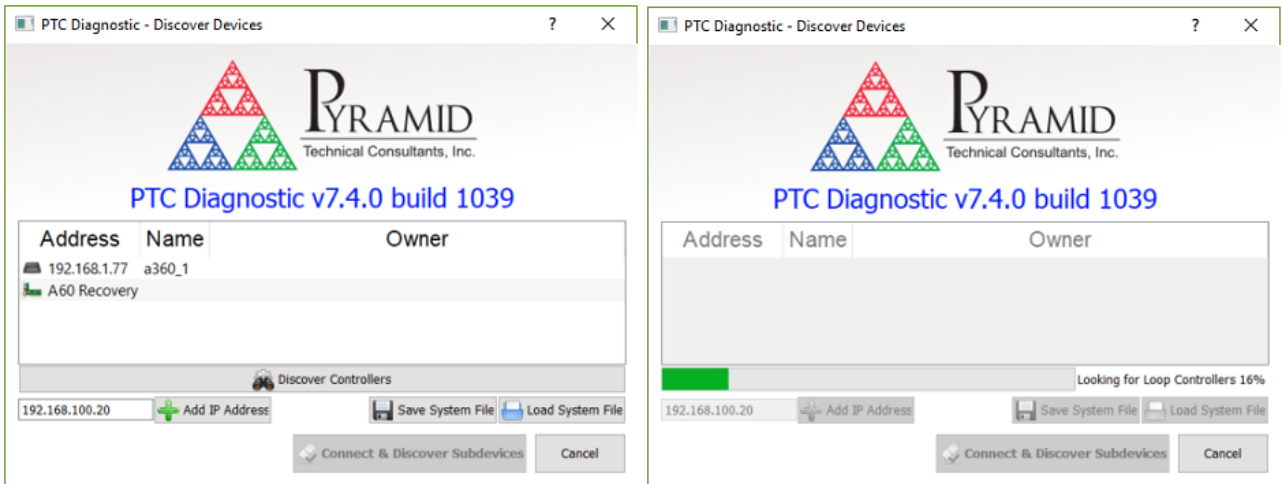

33 : Loop controller discovery

Highlight the controller that is connected to the I3200 and click Connect & Discover Subdevices

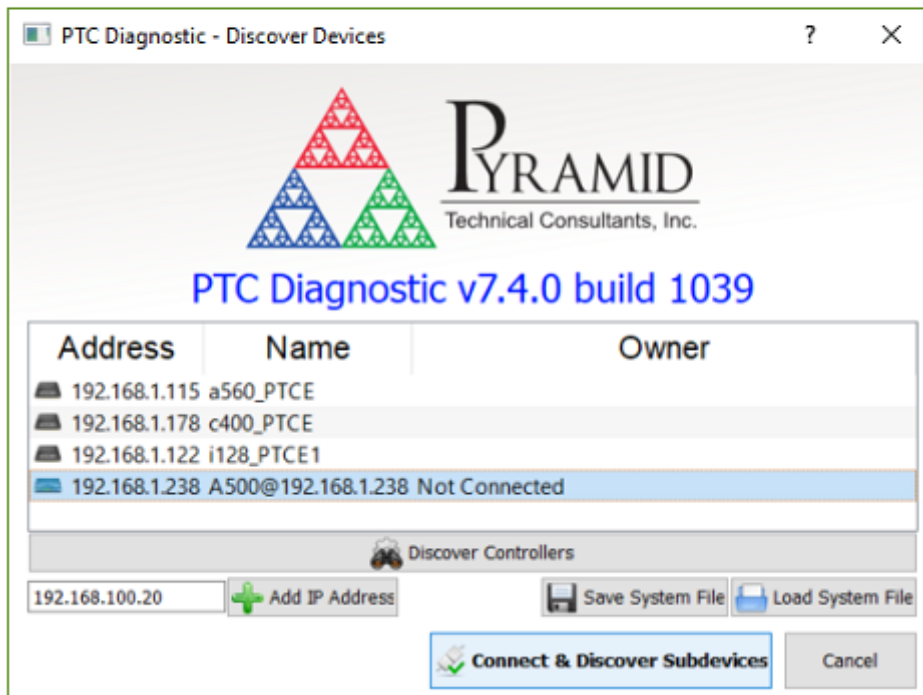
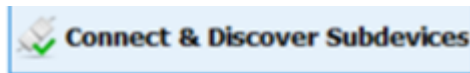

34 : Selecting loop controller to connect

The connection will be made and the connected loop controller will be highlighted in green in the System pane with the connected devices listed below. In this example only the I3200 is present. Double click or click and enter on the I3200 entry to open its screen. The screen items are broadly similar to the PTC DiagnosticG1.

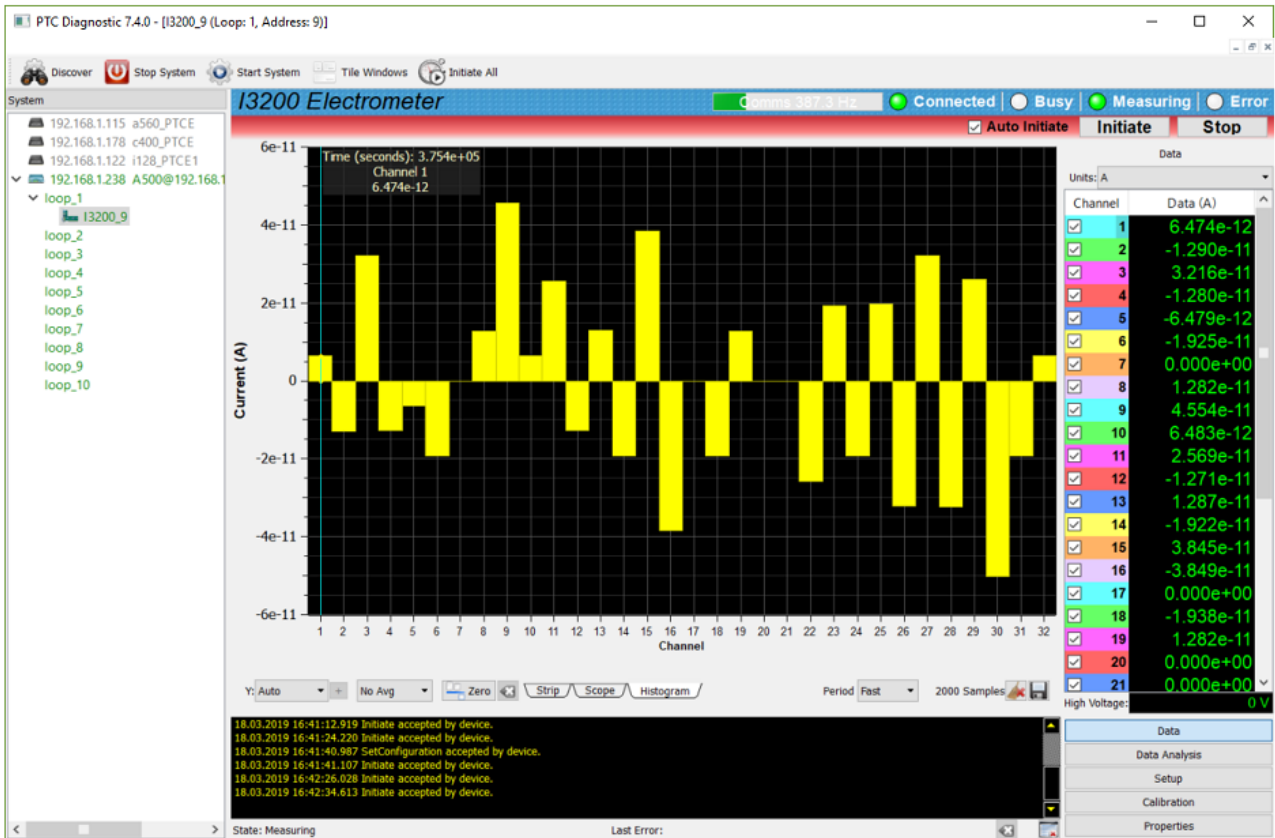

35 : I3200 screen data display screen

A message area at the bottom shows details of the communications between the Diagnostic and the I3200. The control functions are reached via panes selected by the buttons in the lower right corner.

10.2.2 Data analysis pane

Data Analysis

Histogram Peak

Peaks: 1

Center of Gravity

Noise Threshold: 5 %

Window: +/- 2

Gaussian Fit (regression)

Noise Threshold: 5 %

Window: +/- 4

Peak Threshold: 1.00e-15

Sum Threshold: 1.00e-15

Display Full Statistics

X² Window: +/- 4

36 : Data analysis pane

The Diagnostic software can perform continuous calculations on peaks in the histogram display. The Center of Gravity calculation displays the fractional channel value that is the centre of gravity of the contiguous channels either side of the maximum channel that are higher than Noise Threshold % of the maximum, and that are not more than Window channels either side of the maximum.

The Gaussian Fit calculates the Gaussian curve that is the best fit to the channels of the contiguous channels either side of the maximum channel that are higher than Noise Threshold % of the maximum, and that are not more than Window channels either side of the maximum. The fit will not be performed if the peak channel is less than Peak Threshold or if the sum of the channels in the fit is less than Sum Threshold. A quality factor for the fit is calculated for the channels up to χ^2 Window either side of the peak.

Selecting Peaks as greater than 1 causes the fit to be performed on additional peaks within the range. This is useful if the I3200 is reading out two axes of a sensor.

For more information on the Gaussian fit algorithm, refer to the technical note on the Pyramid Technical Consultants website (http://www.ptcusa.com/files/technical_notes/TN0010.pdf).

10.2.3 Setup panes

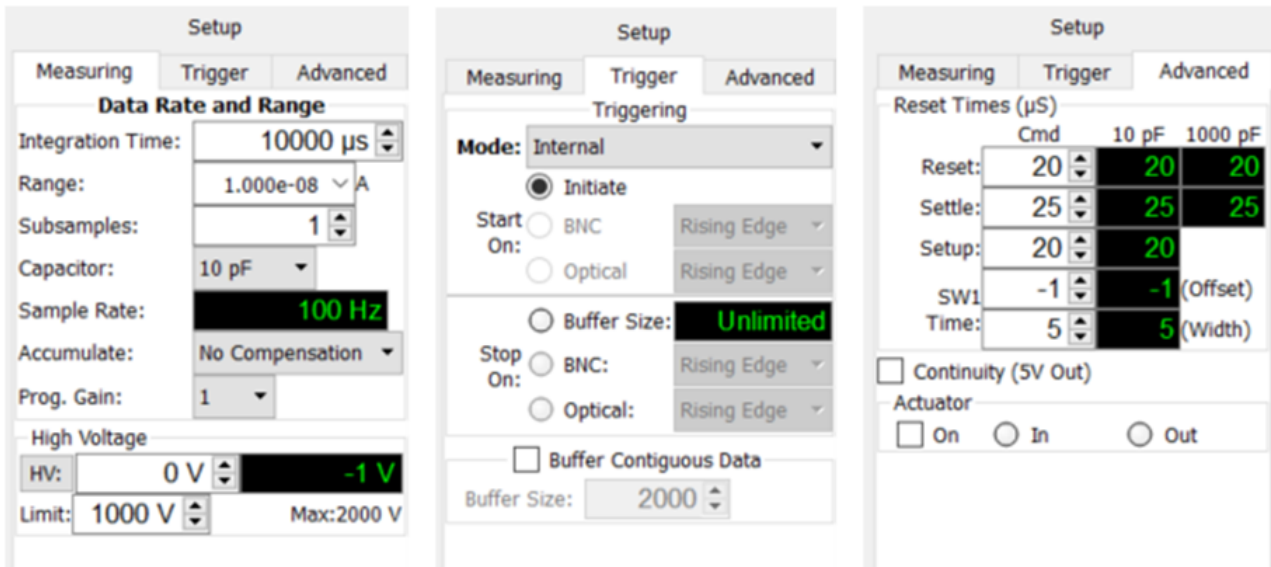

37: Setup panes

Acquisition setup is covered on three sub-panes. Integration time, subsampling, feedback capacitor selection, programmable gain amplifier, charge accumulation and high voltage are controlled on the Measuring pane. Triggering and data buffering is on the Trigger pane. The integrator reset conditions are on the Advanced pane. The Advanced pane also has controls for the +5V test signal that is delivered to pins on the signal connectors and the actuator connector. It also provides controls for the actuator in/out setting and displays the limit switch readbacks.

10.2.4 Calibration pane



38 : Calibration pane

The calibration pane allows you to enable the 83.3 nA calibration current and send it to any one of the 32 channels. Clicking the Calibrate button runs the automated self-calibration process, after issuing warnings that the existing calibration factors will be overridden. The calibration can be saved to non-volatile memory, and a saved calibration can be recalled to become the active calibration. The calibration factors can also be saved to a csv file on the host compute . Pressing Clear resets all the active calibration factors to default (0.000).

10.2.5 Calibration pane

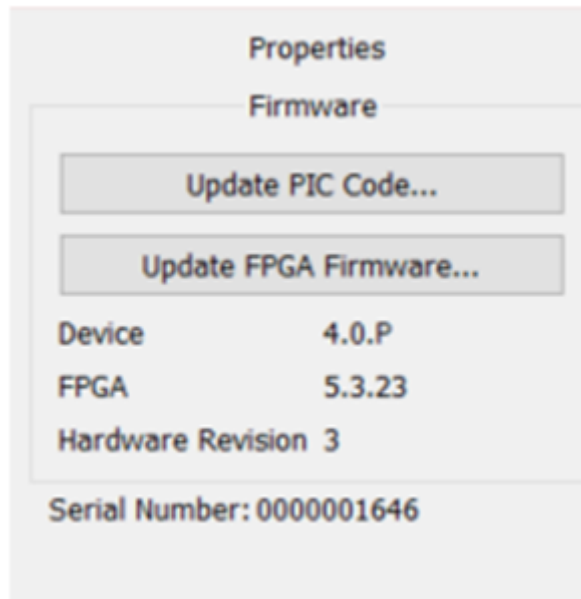

39 : Properties pane

The Properties pane reports the hardware and software versions, the I3200 serial number, and allows the firmware to be updated.

11 How the I3200 Works - An Overview

The I3200 is a very flexible instrument which uses a charge measurement method that may be unfamiliar to you. This section gives you an overview of how incoming signal current is turned into readings. The underlying details are in the sections that follow.

All thirty-two channels are identical and work in synchronization. So to start with, we can focus on a single channel. Imagine there is a small current that you wish to measure, which may be varying in time.

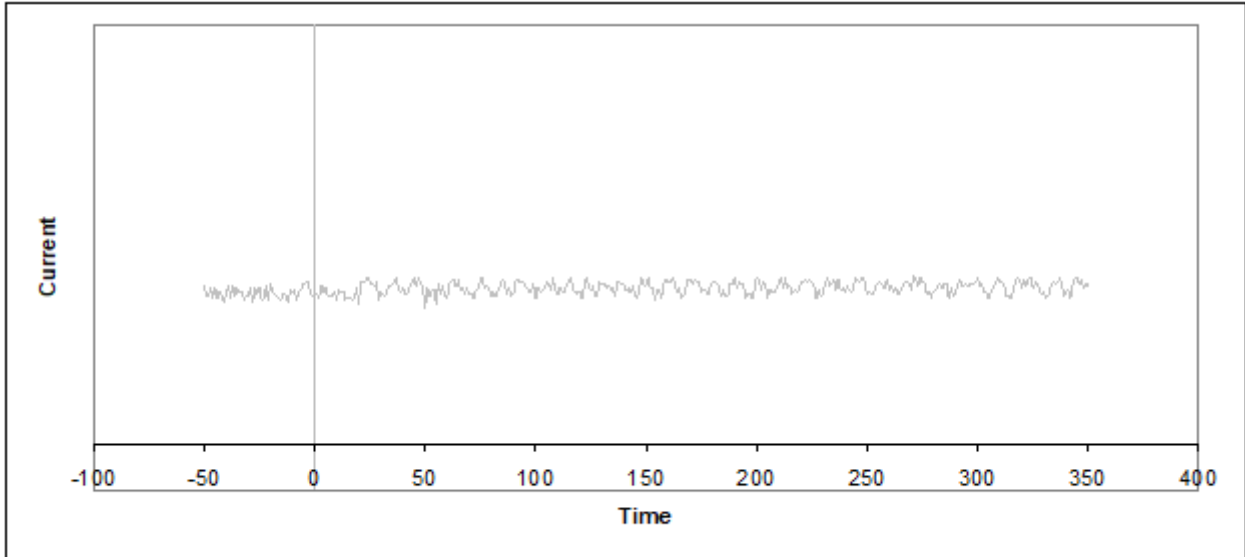

40 : A current to be measured

A conventional current to voltage conversion method would convert this current into an equivalent voltage, and this voltage would be converted to a number by an ADC (analog to digital converter). However this method is less suitable for measuring very small currents because of signal to noise limitations. The I3200 therefore uses a method called gated integration instead.

Imagine that at some point in time, you start accumulating (integrating) this current on a capacitor. The capacitor will charge up, and an increasing voltage will therefore appear across the capacitor.

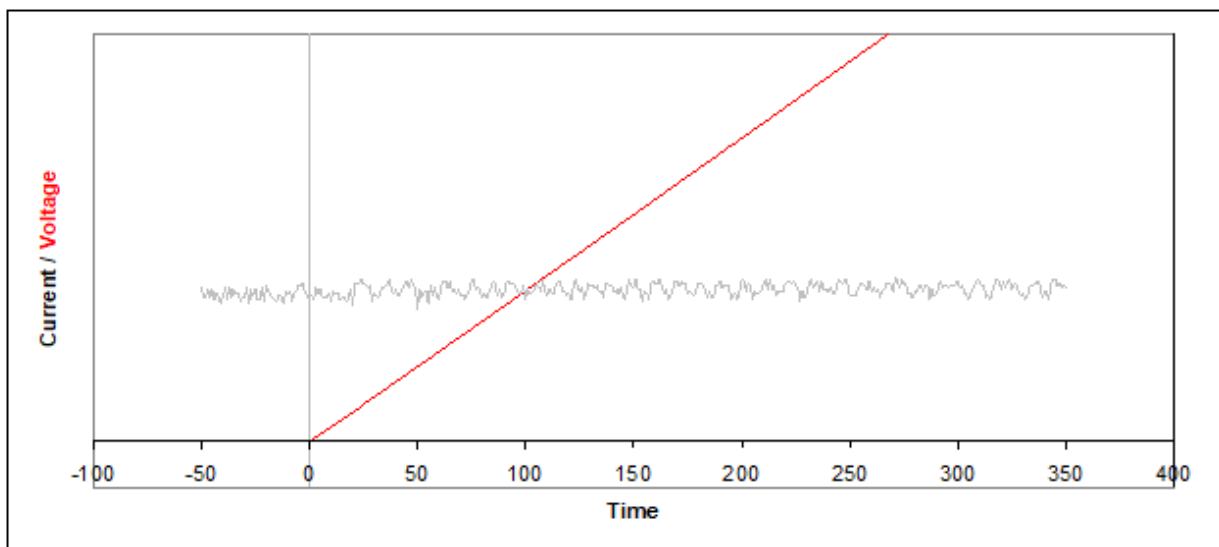

41 : Voltage on a capacitor that is connected at time zero

If we measure this voltage with an ADC, we will know the charge on the capacitor at the time of the conversion. If we measure the voltage at two times, we will know the charge at those times, and therefore the increase in charge over a known time interval.

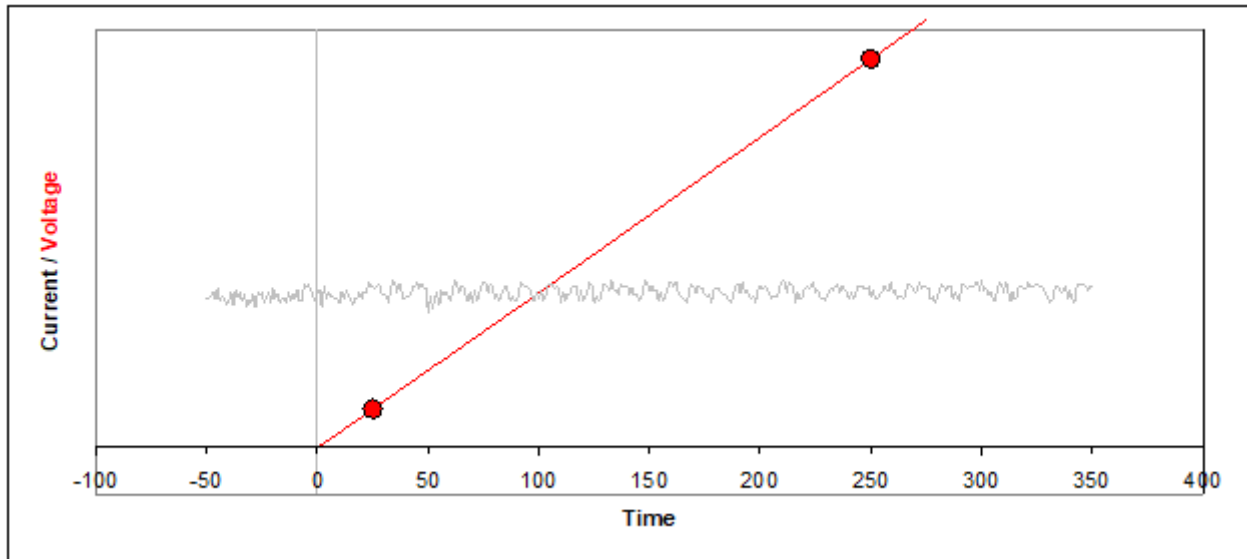

42 : Capturing the voltage at two times

From this we know the average current during that time interval, because current is simply charge divided by time. The time interval is called the integration period.

We cannot allow the voltage on the capacitor to simply increase for ever. The ADC has a specified input voltage range, and there is little point in exceeding it. Therefore we must discharge the capacitor periodically, and this takes some time, typically 20 μsec . Then we can restart the cycle.

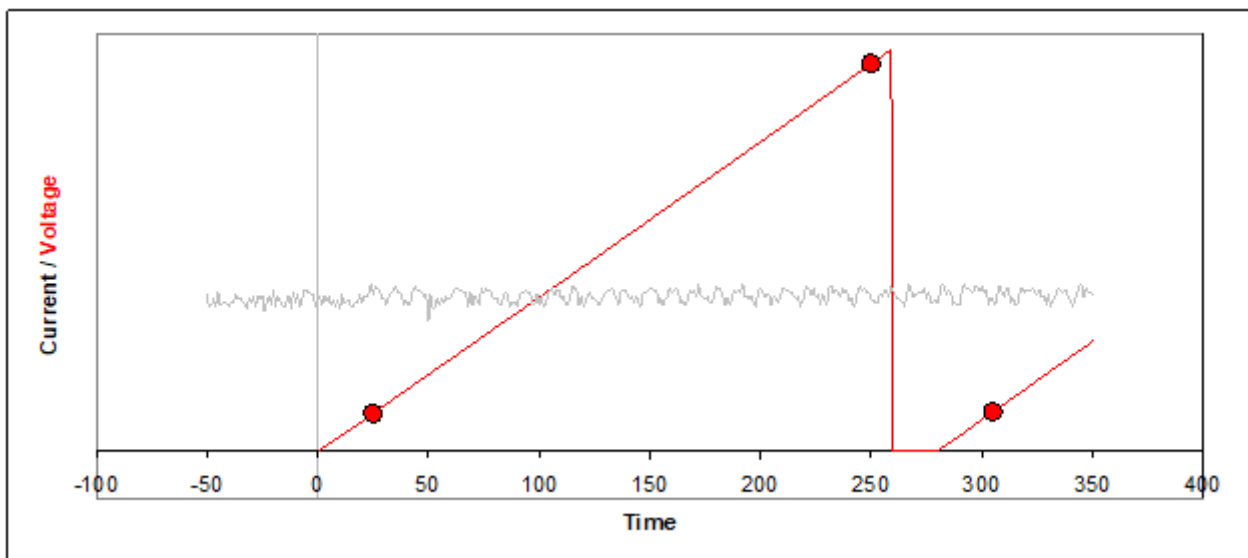

43 : Discharging the integration capacitor and starting a new cycle.

The process of charging the capacitor and discharging to reset is called gated integration. The length of the integration can be controlled in the range 20 μsec up to 65 seconds, and typical working values are in the range 100 μsec to 100 msec. Notice that the first ADC conversion does not take place immediately when the integration starts. This is because the signal is unreliable just after the reset, so we wait a time called the settle time before making the first conversion. This time is normally set to 20 μsec . The settle time can be adjusted, but it is a rather detailed parameter that doesn't usually need to be worried about.

We can get a running measure of the current by simply repeating the integration cycle as many times as we want. Each time we can divide the measurement of charge that is the difference between the ending and starting ADC values by the time interval between them to get the current reading. The number of readings you request from the I3200 is called the trigger count. You can set it to “infinite” if you want, in which case readings will continue until you stop them.

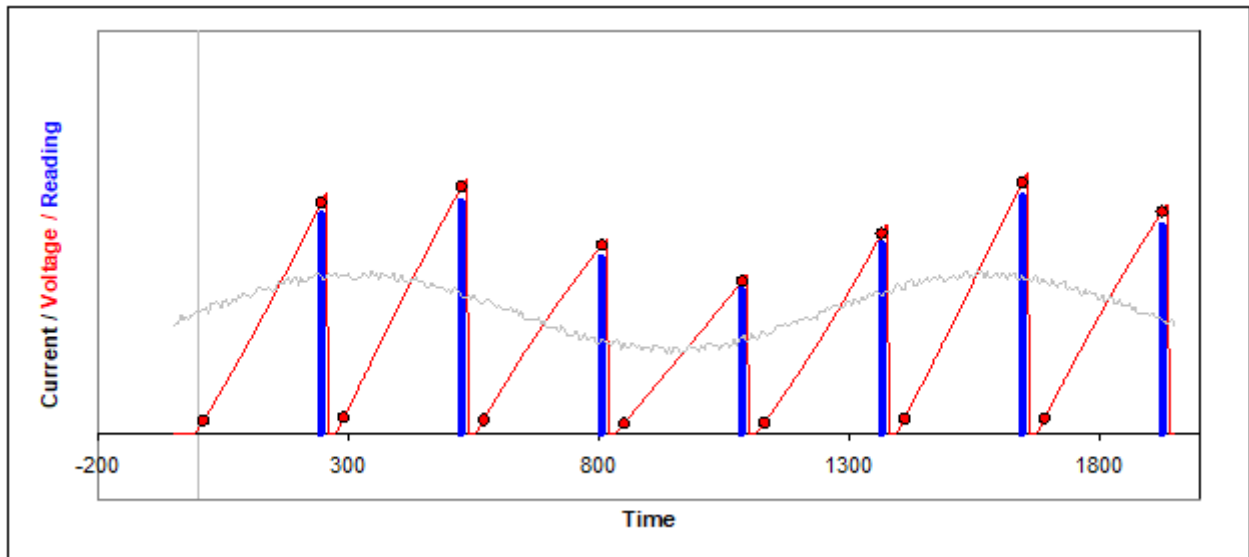

44 : Repeated integrations to sample a continuous current signal. The blue bars indicate the readings; each is the final ADC value minus the starting ADC value for that integration.

There are some points to note. Firstly, notice that the readings are very clearly linked to the time of their integration. Because of the resets, there is no influence at all from earlier integrations. Next, notice also that we get no information about how the current may have varied within each integration - we see only the average. Finally, notice that we are not measuring at all during the resets. If you choose short integration times, the reset time might be a noticeable fraction of the overall time.

Why would you choose any particular integration time? The first consideration is the size of current you expect to measure. For a given charge integrating capacitor, the longer the integration, the smaller is the maximum current you can measure, and the more sensitive the I3200 is to very small currents.

The next consideration is timing. If the current you are measuring is only present in a short pulse, there is little point in integrating longer than this, because you will simply be measuring extra noise. If the current is continuous but has variations that you wish to measure, then you must have integrations short enough to be sensitive to the variations, rather than smoothing them out.

The final consideration is filtering. A given integration time, used repeatedly to measure a continuous current, acts as rectangular low-pass filter. This has the property of completely suppressing frequencies in the signal which correspond to the integration period. If you are troubled by 60 Hz noise, for example, then using an integration period of 1/60 seconds will eliminate the problem.

The I3200 provides a lot of flexibility in how measurements are made. Let's look at some of the parameters.

Current range

You can set the integration time, choose between two integration capacitors, and also choose the gain of an amplifier stage that follows the integrator. The nominal full scale current you will get as a result is given by $(10 \cdot C)/t$ where C is the capacitor size in farads and t is the integration time in seconds. For example, if we select the 10 pF capacitor and integration time 250 μ sec, then the full scale current will be 0.4 μ A.

Time resolution

You are not limited to having ADC readings only at the start and end of the integration cycle. A parameter called subsamples increases the number of conversions, and therefore provides

information about what the signal is doing within each integration. Subsamples = 1 is the basic case, as illustrated above in figure 43. If we increased the value to 9, we would get eight additional intermediate readings. We could use these to see how the current was changing during the integration. If the current suddenly changed in the middle of an integration, for example, we would be able to see more exactly when this happened. The smallest time step between subsamples is 20 μsec .

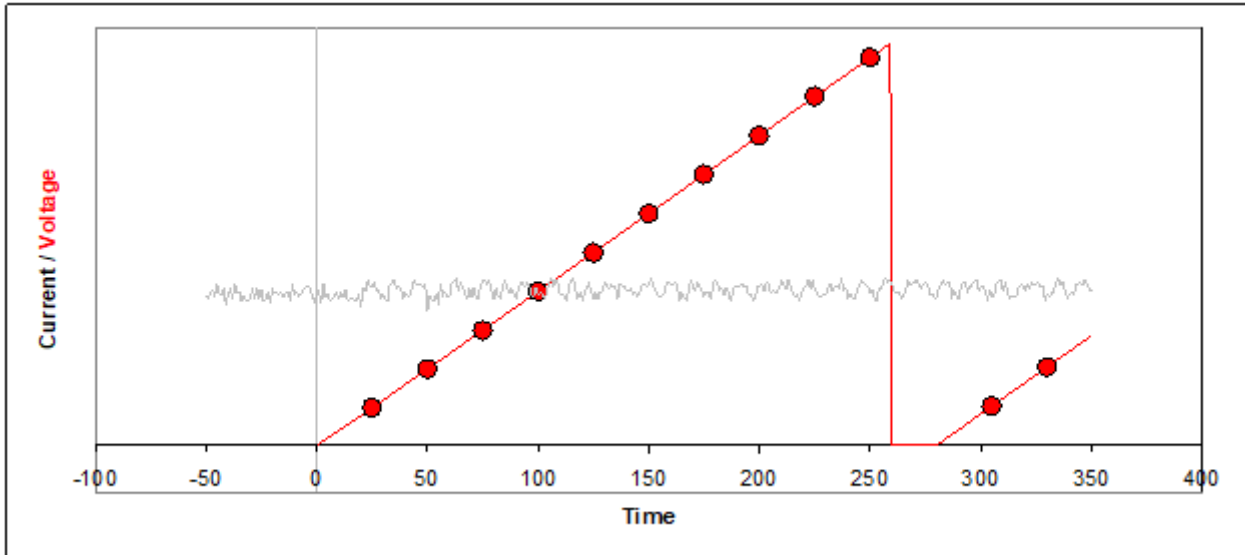

45 : Sub-sampling, nine subsamples (the first conversion is the offset subtracted from the subsequent conversions).

Accumulation

Some applications require that charge is accumulated over an extended period, for example to measure a radiation dose as it builds up to a target value. You could simply add up the successive readings, but the I3200 can do this automatically. If you enable accumulation, there are then three options for how it handles the data that is lost during the reset process. The I3200 can simply ignore the missing data, which can be acceptable if the reset time is small compared to the integration time. It can extrapolate the missing data from the previous integration, which will generally be accurate unless the signal is varying very rapidly. Finally it can use any external capacitance as a temporary store for the current during the reset.

Triggering

In many cases you will need to coordinate the I3200 measurements with external events. You can preset the I3200 with all the measurement parameters such as integration time, number of sub-samples, capacitor selection and so on, then initiate it ready to respond to a trigger signal. The preset measurement sequence will start as soon as the trigger arrives. Remember that the readings don't occur at the exact moment of the trigger, because the integration process has to occur first. The settle time must pass, then the ADC conversions occur at times according to the measurement parameters. You get time stamps back with the data, so you can see afterwards when the readings were captured.

You can control the number of readings that follow the trigger, with a parameter called trigger count. Each reading is one count. Therefore if you specify a trigger count of nine and a sub-sample of 1, the I3200 will do nine full integrations and you will get nine readings. If you increase the sub-sample number to nine, the I3200 would do one full integration only. You would still get nine readings as requested, but now these are the subsamples from within the single integration.

There are various ways of responding to the trigger signal. You can specify whether signal is electrical or optical, whether a rising or falling edge, and how the I3200 should respond to the end of the trigger pulse. The end of the pulse can be ignored (external start mode), or it can be used to

terminate the measurement sequence (external start-stop mode), or it can be used to suspend the measurement sequence (external start-hold mode).

Self-testing and calibration

The I3200 can calibrate itself on all channels fully automatically, and it stores the resulting factors so that it can provide results in physical units (amps or coulombs). You can also turn on the calibration current at any time and send it to any channel to get a performance verification.

There is in addition a switchable test voltage that can be sent out from the I3200 to external resistor networks, for checking external circuit continuity.

12 Principle of Operation

12.1 Gated Integrators

The I3200 uses the gated integrator method. This is a particularly effective technique for measuring small amounts of electrical charge. The charge accumulates on a small low-leakage capacitor in the feedback loop of an operational amplifier, with the result that the voltage at the amplifier output is the integral of the current that flows into the input.

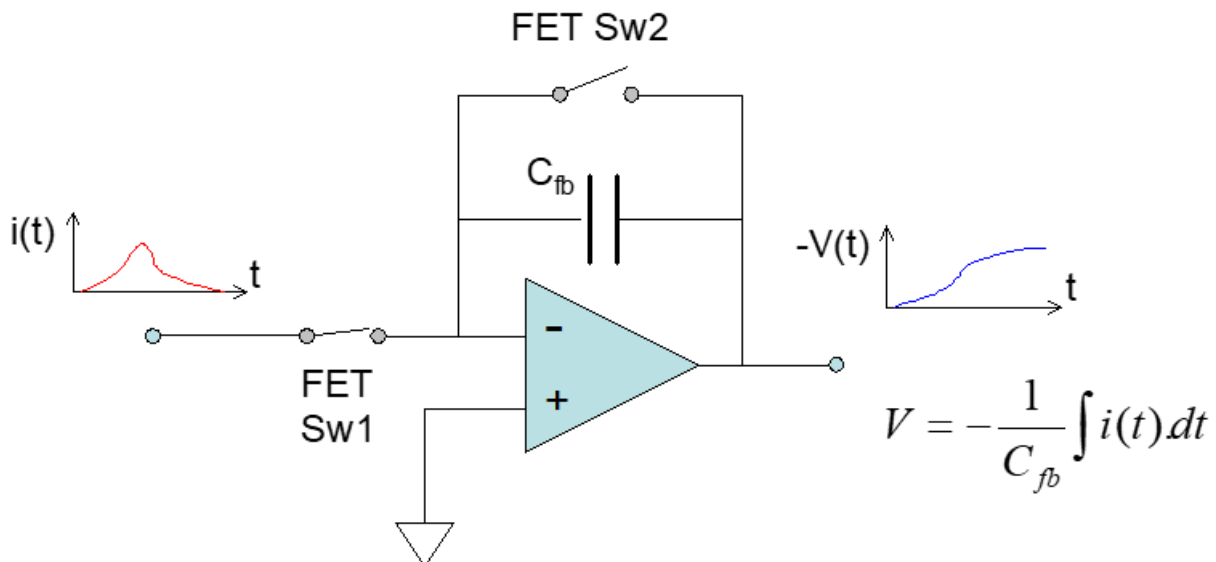

46 : The basic gated integrator circuit.

Integration starts when FET switch Sw2 is opened. The current into the input can be negative or positive. The voltage at the output of the amplifier is sampled and digitized by an ADC. Calibration with a stable, accurately known test current allows variables such as the exact size of the feedback capacitor, buffer amplifier gain and ADC gain to be compensated in one gain factor. There is a factor for each input channel. At any time t after the start of the integration, the accumulated charge is thus given by

$$q_{meas} = k(ADC_t - ADC_{start})$$

where k is the gain factor. The data can also be presented as an average current in the time interval between the readings, because that interval is known accurately.

$$i_{meas} = \frac{k(ADC_t - ADC_{start})}{t}$$

As the integration proceeds, this measure of the average current achieves increasing signal to noise ratio, as more charge is accumulated and the low pass filtering roll-off due to the increasing integration time moves to lower frequency.

The inherent integration is very effective in reducing noise, being in effect a rectangular low-pass filter with -3dB response at $0.44/t_n$ Hz and zero response at N/t Hz, $N=1,2,3,\dots$. Known dominant noise frequencies, for example line voltage interference at 50 Hz or 60 Hz, can be completely suppressed by choosing $t_{per} = 1/50$ or $1/60$ seconds, or integer multiples thereof.

Readings are available at times $n \cdot t_{sub}$ during the integration, where $n = 1 \dots N$ with N the number of sub-samples requested in the integration period, t_{per} , and $t_{sub} = t_{per} / N$. Figure 47 illustrates how a portion of the input waveform is integrated by the opening of Sw2. ADC readings are taken for the

sub-samples, with ADC_{start} being subtracted from each subsequent sample to produce a charge reading.

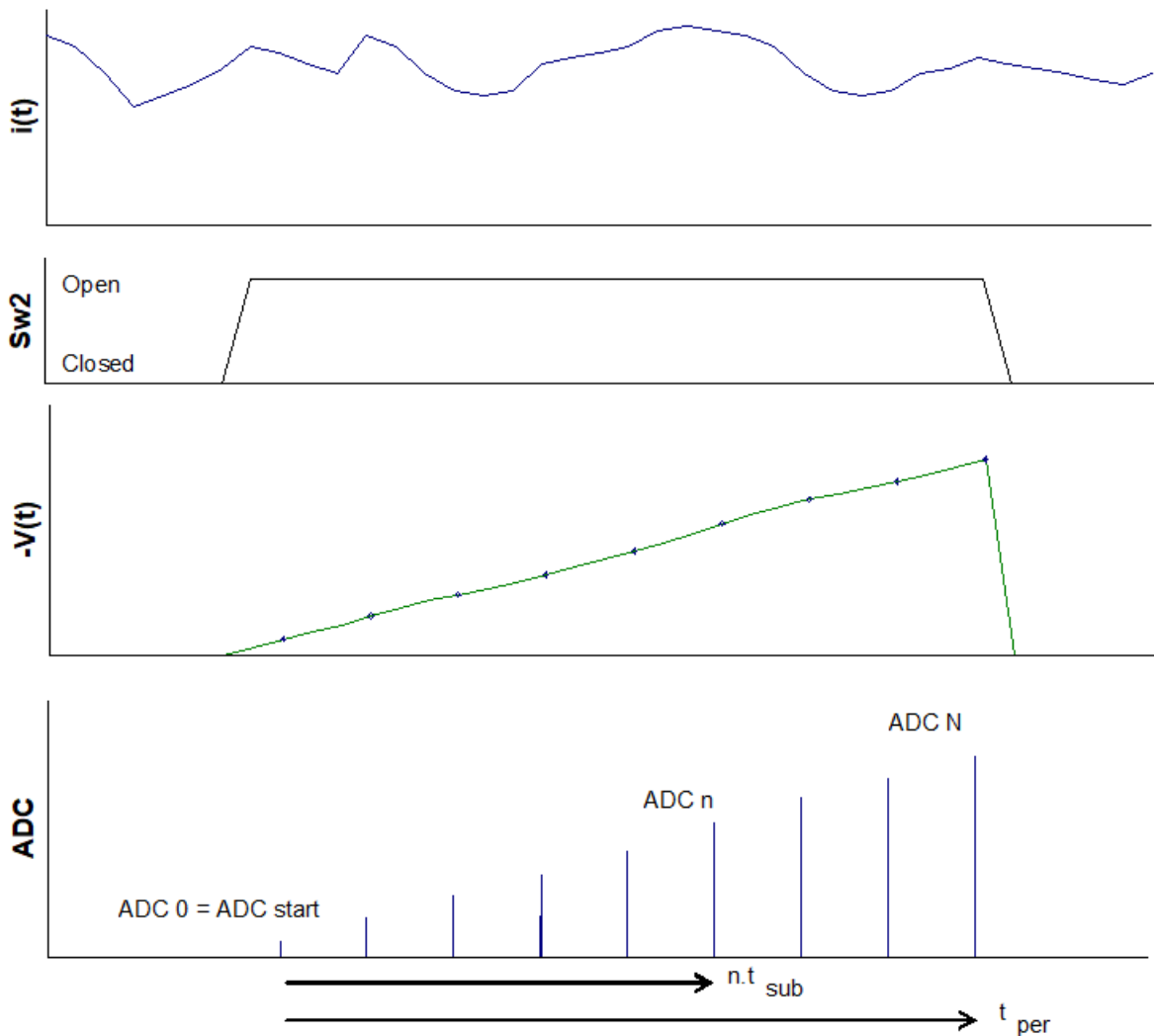

47 : Data acquisition timing diagram. The plots are (from the top) illustrative input current waveform; integrator gate $Sw2$ state, integrator output with ADC sample points shown; ADC readings.

Integration cannot proceed indefinitely because the charge amplifier output voltage cannot exceed its voltage supply rails. It is necessary to reset the integrator periodically, at a rate determined by the average input current and the size of the feedback capacitor. After the defined integration period, t_{per} , switch $Sw2$ closes to short the feedback capacitor and release the charge, so zeroing the integrator ready for the next cycle.

The reset time needs to be sufficient to completely clear the accumulated charge through the FET on resistance, and thus depends upon the size of the feedback capacitor. There is also a short settle time allowed after opening $Sw2$ to start the integration before the start ADC reading is taken, to allow transients to die away. A further time associated with the reset, called the setup time, accounts for the fact that the ADC conversions are not generally exactly aligned with the end of the specified integration period.

Because the ADC conversion period can be considerably shorter than the integration period, the I3200 can use sub-integration period sampling to track the charge build-up on the feedback capacitor between resets, as described above. This enables several useful measurement techniques and features in the I3200: When the average current being measured is very low, so that a long integration period is needed to get a precise value, sub-integration sampling allows intermediate

current values to be returned, rather than having to wait for the integration to end before getting a new reading. Additionally, time-resolved data is available from within the integration period. This allows, given adequate signal to noise ratio, reconstruction of the shape of a pulse that occurred within one integration period.

13 Calibration and Self-test

13.1 Calibration

13.1.1 Calibration source

A precision current source is built into the I3200. The value is 500 nA or 83.33 nA depending on the hardware revision of the I3200. The reduction to 83.33 nA was introduced in revision 3 hardware to allow the calibration to be performed with a 1 msec integration time on the 10 pF feedback capacitor. This allows a more accurate calibration.

The calibration source is a true current source, meaning that it delivers this current irrespective of the impedance of the measuring device, within the limits of its voltage compliance. A network of semiconductor switches routes this current to any one of the I3200 channels under software control, so you can confirm that the selected channel functions correctly and gives an accurate reading. Note that this current is added to any current that may already be present on that channel.

13.1.2 Automatic Self-Calibration

The automatic calibration function of the I3200 uses the calibration source to measure gain factors for each channel, and thus level the sensitivity across all the channels. This is necessary primarily to compensate variation in the values of the feedback capacitors, but also includes any gain errors in the other amplifier stages and the ADC.

Before doing the calibration, you should ensure that there are no signal currents that would upset the calibration. The safest way is to disconnect the inputs, although it is acceptable to confirm that all the measured currents are very low and noise-free. You should also ensure that the reset and settle times are at their recommended default values. The I3200 switches the calibration current routing and feedback capacitor selection and accumulates multiple readings for each channel in order to get noise-free calibration values. An error is flagged if the gain factors vary by more than 0.3 from the nominal value of 1.000. The 64 values are stored in EEPROM in the I3200, in one of two locations.

Note that calibration factors are only stored for a PGA setting of 1. The readings for other PGA settings assume that the PGA scalings are their nominal values. As a result, you should only rely on the absolute accuracy of the I3200 when the PGA setting is 1.

13.1.3 Using the calibration current source to identify cross-talk

If you turn on the calibration current, it should only show up on the selected channel, with negligible cross-talk to other channels. However there may be an inadvertent connection between two channels in your sensor system or cabling. In this case you may see current in more than one channel when the calibration is enabled with the external circuit connected. This can in fact be a useful means of diagnosing unwanted shorts in your system. Simply step the calibration current through all 32 channels and confirm that the whole current shows only in the expected channel.

13.2 Continuity test signal

The I3200 provides a +5 VDC test voltage that can be switched to pins on the signal and actuator connectors. You can route this through high value resistors on your system to generate currents that can be fed back to the signal inputs through your wiring, and therefore test the integrity of the signal paths. The resistance between channels must be high compared to the I3200 input impedance to minimize crosstalk. For critical applications where very low currents are being measured, you should not have the resistors fitted when taking important data. Some experimentation will show whether you can tolerate test resistors in your application. Figure 49 shows a suggested resistor network that injects about $(5R_{D2} / (R_{D1} + R_{D2})) / (R_S + R_I + R_{IA})$ amps into each channel when the test voltage is enabled, where R_I is the input impedance of the I3200, and R_{IA} is any additional internal series resistance that you specified at the time of order. R_I is about 2 kohm, and can safely be ignored.

The circuit can be altered to suit individual needs. Higher R_S values than 1 Mohm can be used to supply reduced current to the detector electrodes, if desired, which will reduce any crosstalk. The ratio of the voltage divider R_{D1} , R_{D2} can also be altered according to the current you wish to use for continuity testing, or it can be omitted altogether.

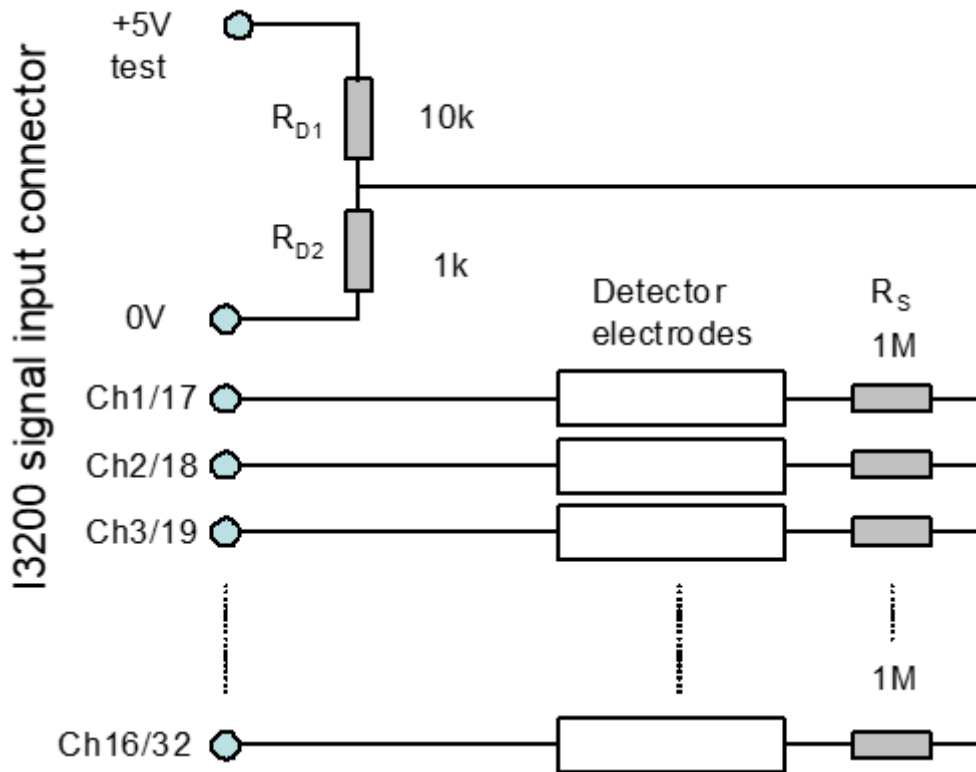

48 : Resistor network for testing external signal path continuity.

Addition of individual switches to the circuit of figure 49, as shown in figure 50, allows any combination of one or more channels to be fed with current via the external circuitry. This can assist you to ensure that the sensor elements are correctly allocated to the I3200 input channels.

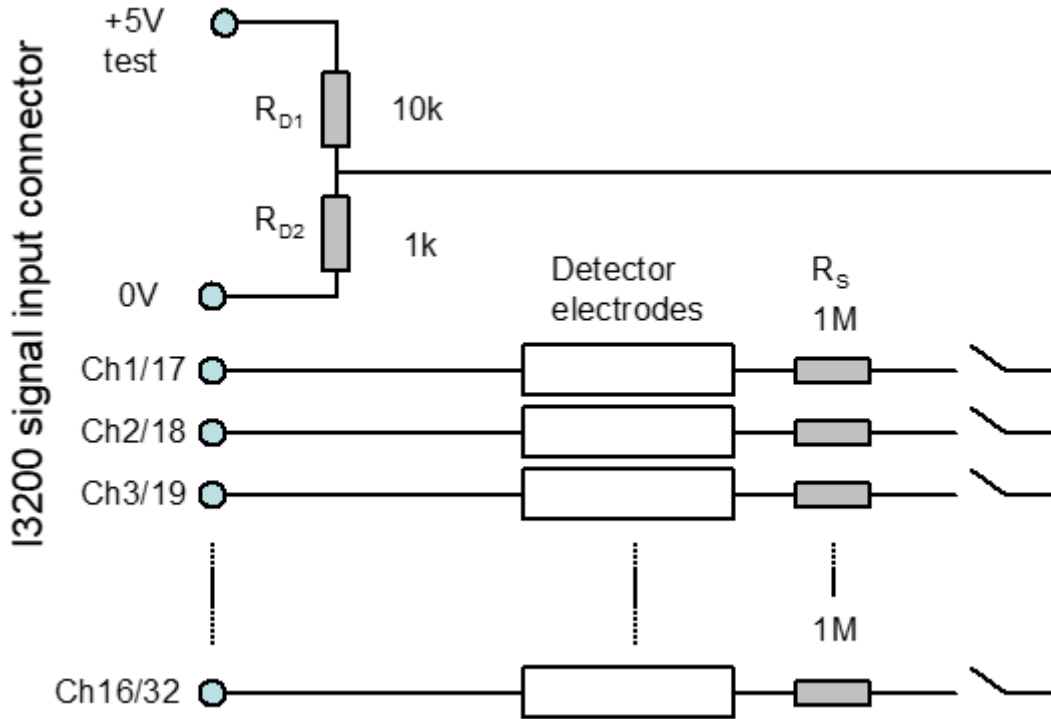

49 : Resistor network with switches

A further variant of the test circuit can produce a simple pattern of currents, for example an ascending staircase. This can provide an “at a glance” indication that your external connections are in the correct sequence.

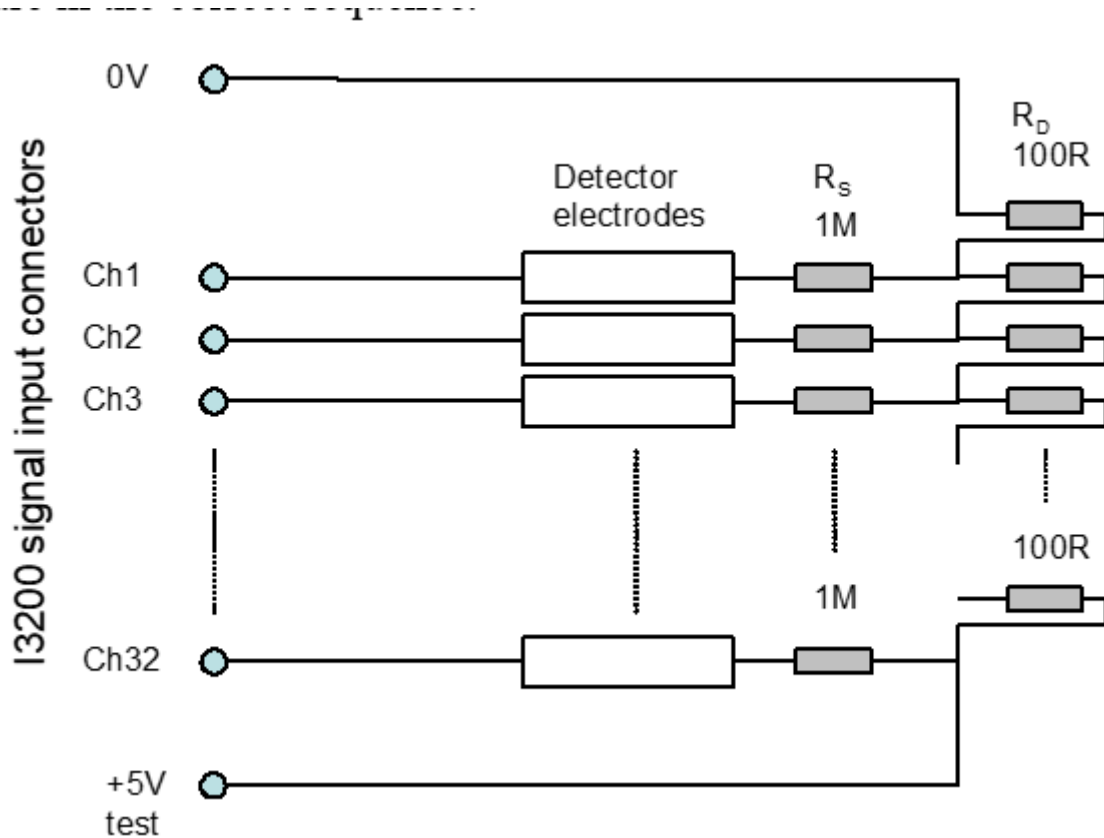

50 : Continuous resistive divider to produce a regular ascending staircase in 0.156µA steps to 5.0 µA.

13.3 Flat Field Compensation

The I3200 is well-suited to reading out arrays of identical sensors, for example position-sensing gas chambers, photodiode arrays, or stacks of sensors used for particle range measurement. Whilst the I3200’s internal calibration process will ensure that the channels have very closely-matched sensitivity to current, the sensors themselves are likely to have some variation in response. The PSI Diagnostic software allows this variation to be compensated, so that the combination of sensor and I3200 gives a uniform response to a uniform irradiation (a flat field).

You access the feature on the PSI Diagnostic Setup tab, where it is a sub-tab in the calibration area.

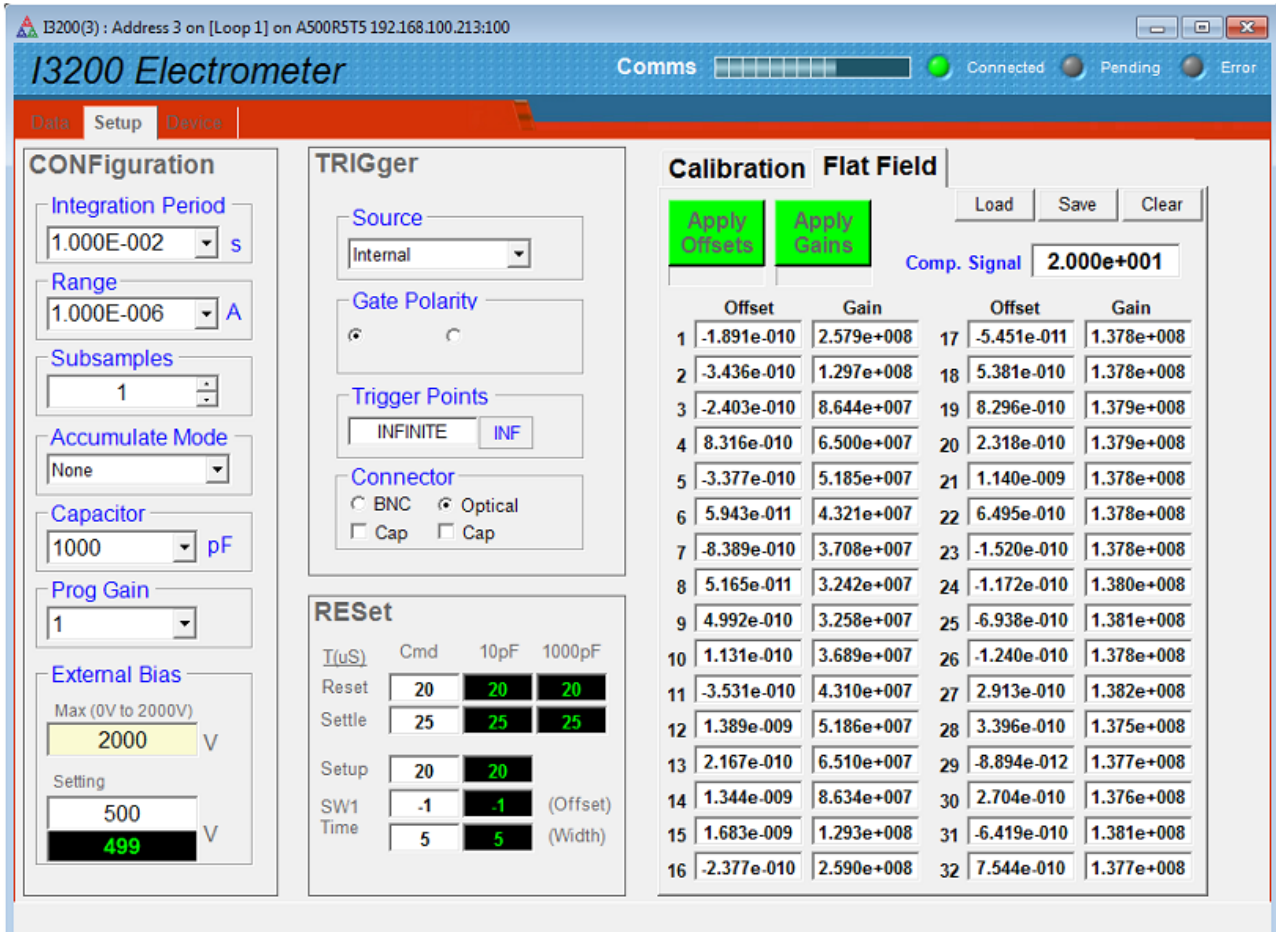

51 : Flat field compensation utility

The software stores a compensation offset and gain factor for each channel, and the set of values is associated with a particular I3200 serial number.

13.3.1 Obtaining flat field compensation parameters

The procedure to obtain the factors is as follows:

1. Ensure that the I3200 is calibrated in the usual way.
2. Connect the I3200 is connected to the sensor, with bias voltage applied as necessary, but with no signal present. This should be a representative background. Click the Apply Offsets button; the sensor offsets will be recorded by the software.
3. Introduce a uniform (flat field) irradiation. Enter the value of this uniform irradiation in the Comp. Signal box. The units can be whatever is appropriate for the incident irradiation. Click the Apply Gains button. The software calculates the factors.
4. If you are happy with the factors, click Save to make a record on the host computer. Whenever the particular I3200 is connected, the factors can be recovered with the Load button.

13.3.2 Applying flat field compensation

The compensated readings are accessed via the "Comp" unit selection on the Data screen. In the following example, figure 53 shows a simulated deliberate non-uniform response before compensation, due to a non-uniform response of some sensor, greatly exaggerated for the purposes of illustration. The required flat field level value is 20 units, but the actual average before compensation is different.

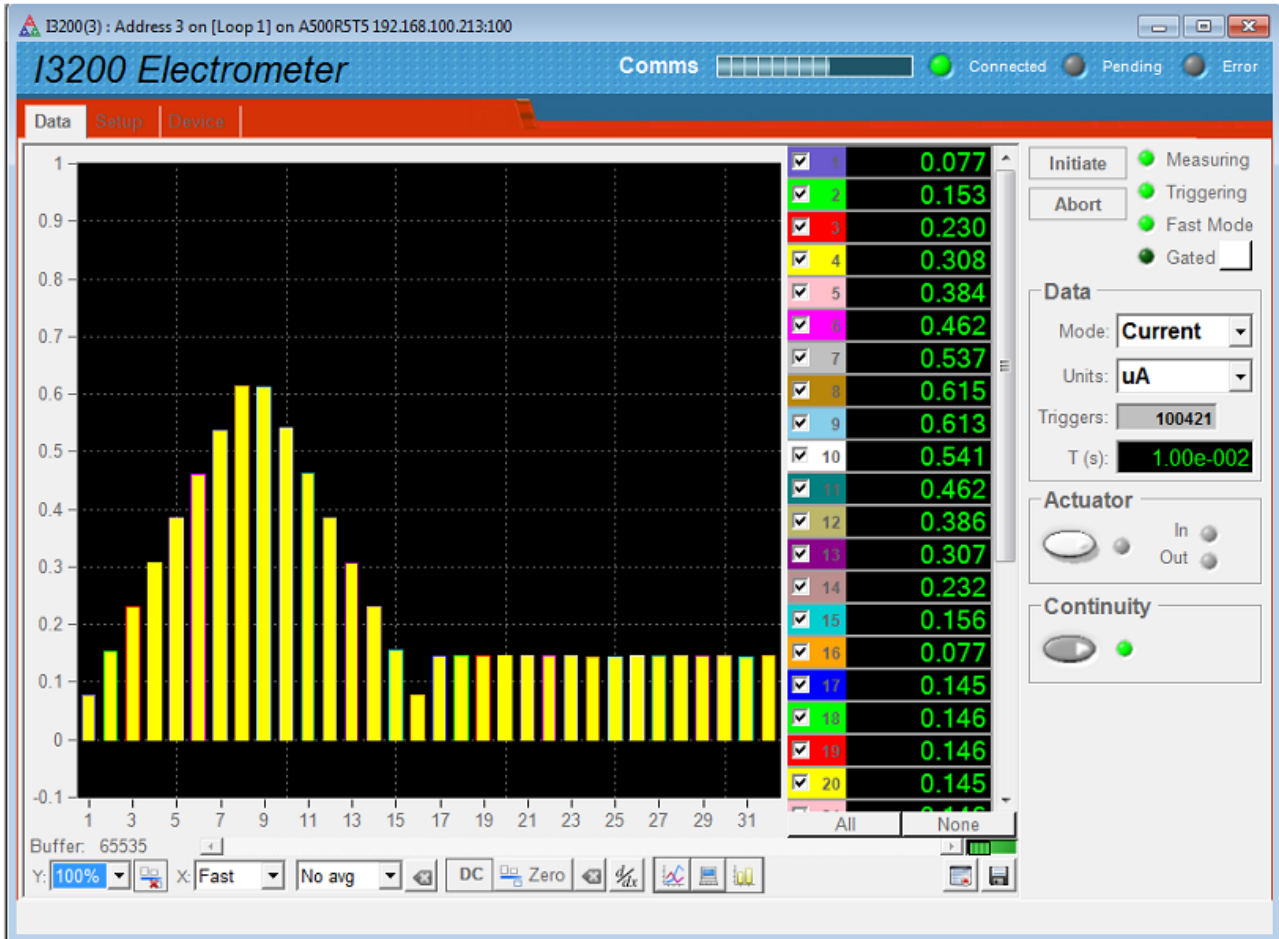

52 : Simulated non-uniform sensor response to uniform irradiation

This stimulus was then used for a compensation calibration. The next figure shows how the same stimulus then appears when measured in compensated units. The response is flat with a value of 20, as required.

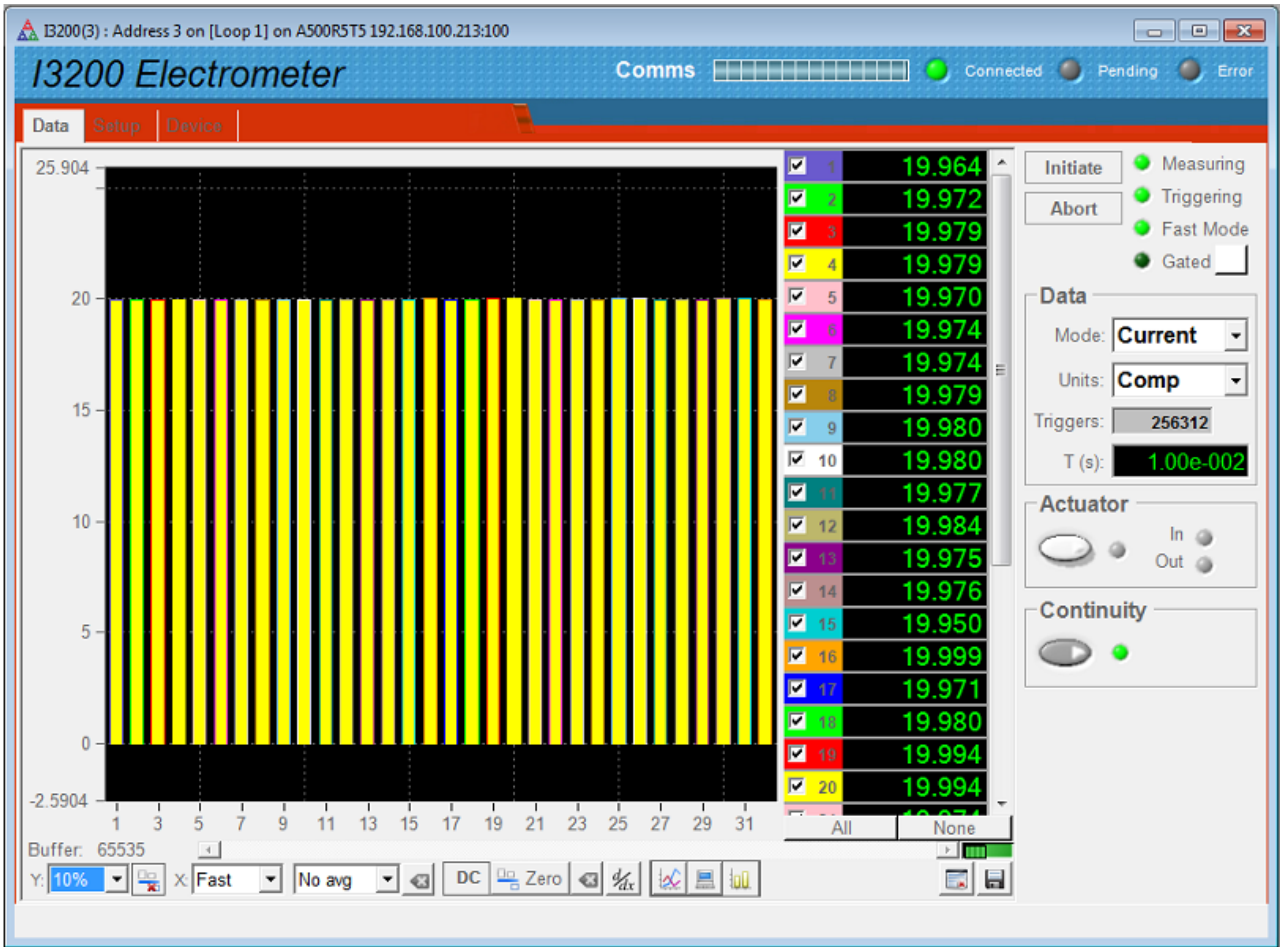

53 : Uniform response recovered using compensated units.

14 Making Measurements

14.1 Current and charge ranges

The I3200 measures the charge q that is integrated on the feedback capacitor. The exact integration time t_{per} is returned with every reading, so the values are simply converted to the average current during the integration from

The selection of feedback capacitor, C_{fb} and integration period, t_{per} determines the maximum current i_{max} that can be measured, limited by the ten volt range of the ADC.

The table gives the full scale measurement ranges for the standard feedback capacitors and three example integration periods. The actual full scale ranges will differ slightly from channel to channel due to the small conversion gain variation that is compensated by the calibration factors. Which ranges are useful will of course be limited by the offsets and noise levels in your system.

Capacitor	FS range (C)	FS range $t_{\text{per}} = 100 \mu\text{sec}$	FS range (A) $t_{\text{per}} = 10 \text{ msec}$	FS range (A) $t_{\text{per}} = 1 \text{ sec}$
10 pF	1e-10	1 μA	10 nA	100 pA
1000 pF	1e-8	100 μA	1 μA	10 nA

In addition to the charges readings in coulombs and integration period in seconds, the returned data also includes a bitwise overrange byte that flags any channels where the reading has gone overrange (ADC value greater than 95% of full scale). The lower four bits indicate overrange positive, and the upper four bits indicate overrange negative.

LSB	Ch1 overrange +ve
	Ch2 overrange +ve
	Ch3 overrange +ve
	Ch4 overrange +ve
	Ch1 overrange -ve
	Ch2 overrange -ve
	Ch3 overrange -ve
MSB	Ch4 overrange -ve

14.2 Integrator Control

14.2.1 Integrator time parameters

The I3200 allows the user a high degree of control over the integration cycle, so you can optimize the operation of the device for your application. The various times that can be programmed are shown schematically in figure 55. The pairs of ADC read pulses correspond to the capture of the odd and even channels. They are 4 μsec apart.

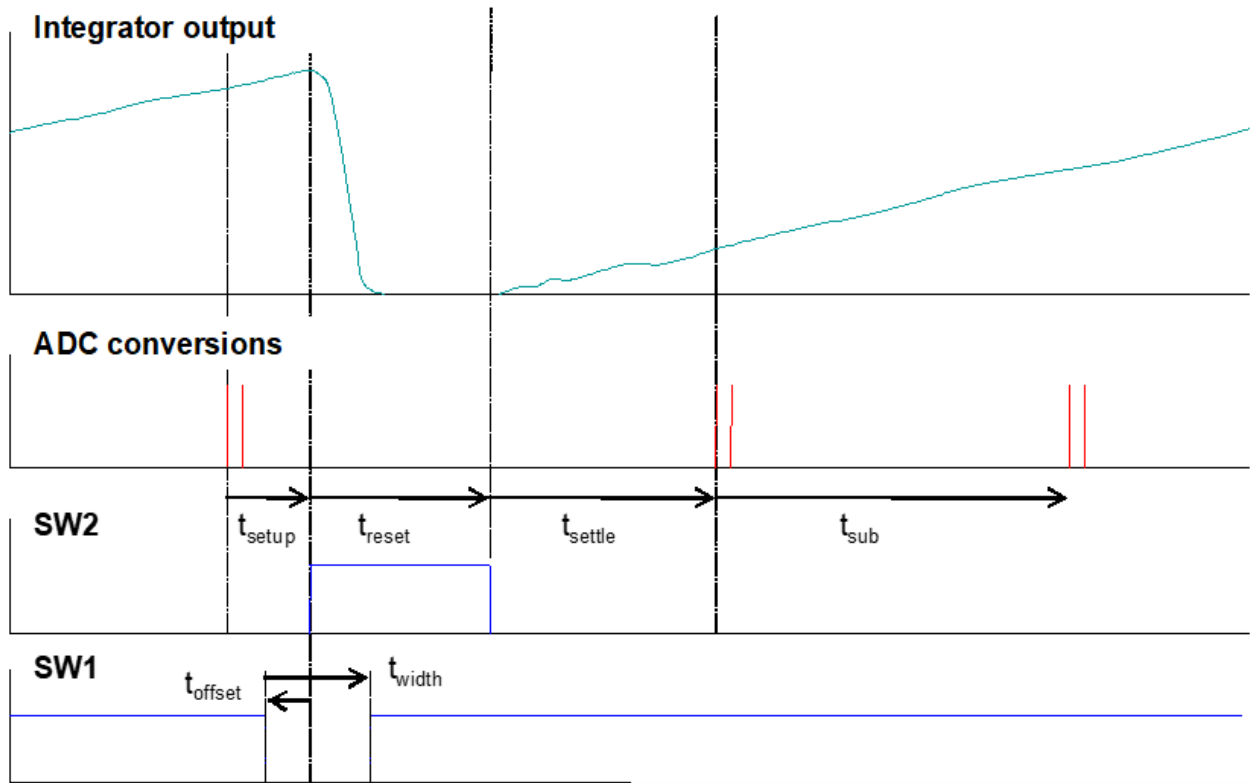

54 : Programmable times for the integrator reset process.

t_{per}	The total integration period, measured between corresponding first and last ADC readings. Minimum 100 μ sec (20 μ s in FastMode with an A500), maximum 65 sec.
t_{sub}	The subsample period. $t_{sub} = t_{per}/n$, where n is the number of subsamples. Minimum 100 μ sec (20 μ sec in FastMode with an A500), defined by the subsample number.
t_{setup}	The time between the last ADC reading in an integration cycle and the closing of SW2 to reset the integrator. This has to be set long enough to ensure that the last ADC readings are not affected by the closing of SW2.
t_{reset}	The time the integrator is held in reset. This has to be set long enough to clear all the charge from the feedback capacitor.
t_{settle}	The time allowed after the integrator reset for the integrator output to settle, before the first (zero) ADC reading is taken. This has to be set long enough to clear the initial noisier part of the integrator ramp, assuming the best measurement precision is required.
t_{width}	The time that SW1 is opened to disconnect the integrators from the signal inputs at the time of reset. This can be beneficial to reduce the perturbation from the reset switching transient charging the cable capacitance.
t_{offset}	The offset (positive, or negative as shown in figure 55) of the SW1 opening from the start of the integrator reset.

The frequency at which new complete integration readings are generated is:

$$F_{update} = \frac{1}{(t_{per} + t_{reset} + t_{settle} + t_{setup})}$$

The live time proportion is given by:

$$\frac{t_{per}}{(t_{per} + t_{reset} + t_{settle} + t_{setup})}$$

The default reset, settle and setup times for the standard and optional feedback capacitor choices are:

C _{fb}	t _{setup}	t _{reset}	t _{settle}	t _{width}	t _{offset}
10 pF	20 μsec	20 μsec	25 μsec	5 μsec	-1 μsec
1000 pF	20 μsec	20 μsec	25 μsec	5 μsec	-1 μsec
100 pF	20 μsec	20 μsec	25 μsec	5 μsec	-1 μsec
10000 pF	20 μsec	20 μsec	25 μsec	5 μsec	-1 μsec

If the livetime proportion is more important than absolute accuracy and precision in your application, then it may be beneficial to reduce the settle, reset and settle times below their nominal values, until you notice an unacceptable degradation in accuracy and precision.

14.2.2 Dynamic feedback capacitor selection

The integrators have the choice of two feedback capacitor values, under software control. All thirty-two channels are switched together. Generally you will select the capacitor to use ahead of your measurement, based upon the expected maximum current and the choice of integration period. However the I3200 also supports a dynamic capacitor switching mode, in which you can change the feedback capacitor for each individual integration.

The switching is controlled by the logic level seen on one of the gate input connectors. If you are using one of the inputs for triggering, then you would use the other for capacitor selection. The level on the selected gate input is checked when the integrator is reset. If it is low, then the small feedback capacitors are selected for the next integration. If it is high, then the large capacitors are selected. This capability is of particular benefit when the approximate magnitude of the currents to be measured correlate with some external parameter, for example the beam current in a particle beam system, or the advanced signal seen on another sensor.

14.3 Continuous Current Measurement

The I3200 can make a continuous reading of the current on its inputs. In this mode it behaves like a sensitive current to voltage converter. The input current can be positive or negative. A positive reading represents conventional current flowing into the I3200. A negative reading represents conventional current flowing out of the I3200.

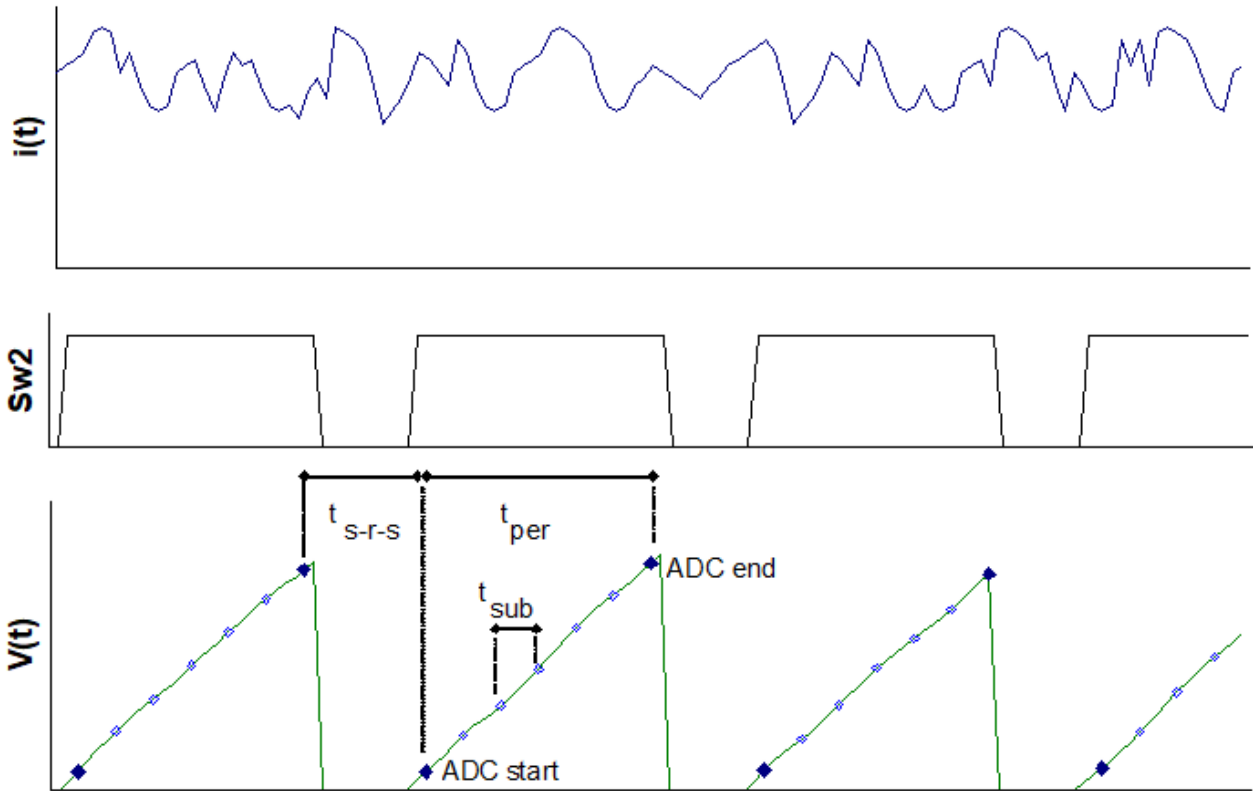

55 : Timing diagram for continuous current monitoring. The deadtime for setup, reset and settle (t_{s-r-s}) is shown relatively large.

Repeated integrations of the specified period are made. Each integration yields start and end ADC values, plus interim values from any sub-integration sampling that has been requested. The final measured current value for one integration is given by

$$i_{meas} = \frac{k(ADC_{end} - ADC_{start})}{t_{per}}$$

where k (coulomb bit^{-1}) includes the stored calibration factor for that channel with the feedback capacitor in use.

The interim current value for the N th sub-integration interval ($N=1,2,\dots$) with ADC value ADC_N is

$$i_{measInterim} = \frac{k(ADC_N - ADC_{start})}{Nt_{sub}}$$

The deadtime (composed of setup, reset and settle time components) while the integrators are being reset does not generally affect the integrity of the current measurement. The only exception would be a case where a significant frequency component of the signal happened to coincide closely with the integration cycle. This can be checked and avoided if necessary by altering the integration period.

14.4 Charge Accumulation Modes

Applications such as radiation dosimetry often require the total charge to be accumulated, so that a process can be halted when a particular value is reached. When charge accumulation is turned on, a running total is kept of the total accumulated charge across all the integrations since the last

initialize. All reported and buffered charge values show this accumulating value. If sub-samples have been specified, these are used as interim values to be added temporarily to the accumulating total. They are superseded by subsequent sub-samples in the same integration period up until the final sample which is logged permanently to the total.

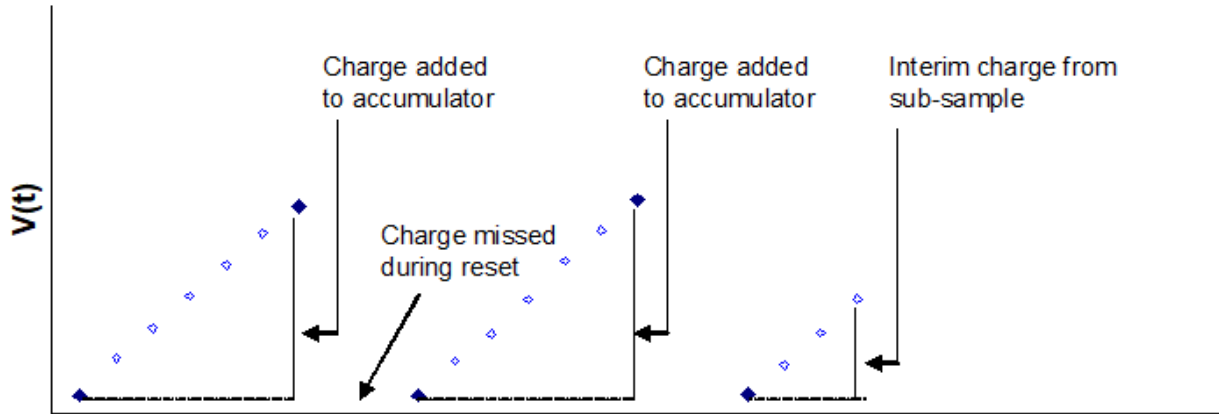

56 : Illustration of integrator voltage at ADC sampling points during charge accumulation. The reset periods are shown relatively large.

There are three alternative means of dealing with the charge that is missed during the integrator resets. These are no correction, interpolation, and no-lost charge.

14.4.1 No correction

Simply ignoring the loss during the deadtime can be appropriate when the deadtime is a very small fraction of the total time. For example, with one second integrations and a 10pF feedback capacitor, the percentage deadtime is about 0.003% of the total time, which is negligible.

14.4.2 Reset time interpolation

The I3200 assumes that the measured charge in the last integration period may be pro-rata extended over the total cycle ($t_{int} + t_{setup} + t_{reset} + t_{settle}$). The charge added to the accumulator for each integration cycle is thus

$$q = i_{meas} (t_{per} + t_{setup} + t_{reset} + t_{settle}) = \frac{k(ADC_{end} - ADC_{start})}{t_{per}} \cdot (t_{per} + t_{setup} + t_{reset} + t_{settle})$$

This approach will only be invalid if there are large, fast changes in the signal which happen to lie within the reset and settle cycle.

14.4.3 Lossless accumulation technique

In critical dosimetry applications it may be important to know the total accumulated charge over a period of time, without making any assumption about what happened during the integrator resets. The I3200 can achieve this for signal sources that can be modeled as a capacitance in parallel with a very high resistance. This is a good model for ionization chambers, isolated electrodes that collect charged particles, and photodiodes. However the accuracy of this method is highly dependent on the particular sensor arrangement, so we recommend that you test it very carefully with known signals before using it routinely. If in doubt, then the interpolation method described above is generally less prone to unexpected behavior.

The method is to use the inherent capacitance of the sensor, C_s , to capture the charge during the integrator reset cycle, then to transfer this charge onto the feedback capacitor at the start of the next integration. The switching sequence is illustrated in the figure below.

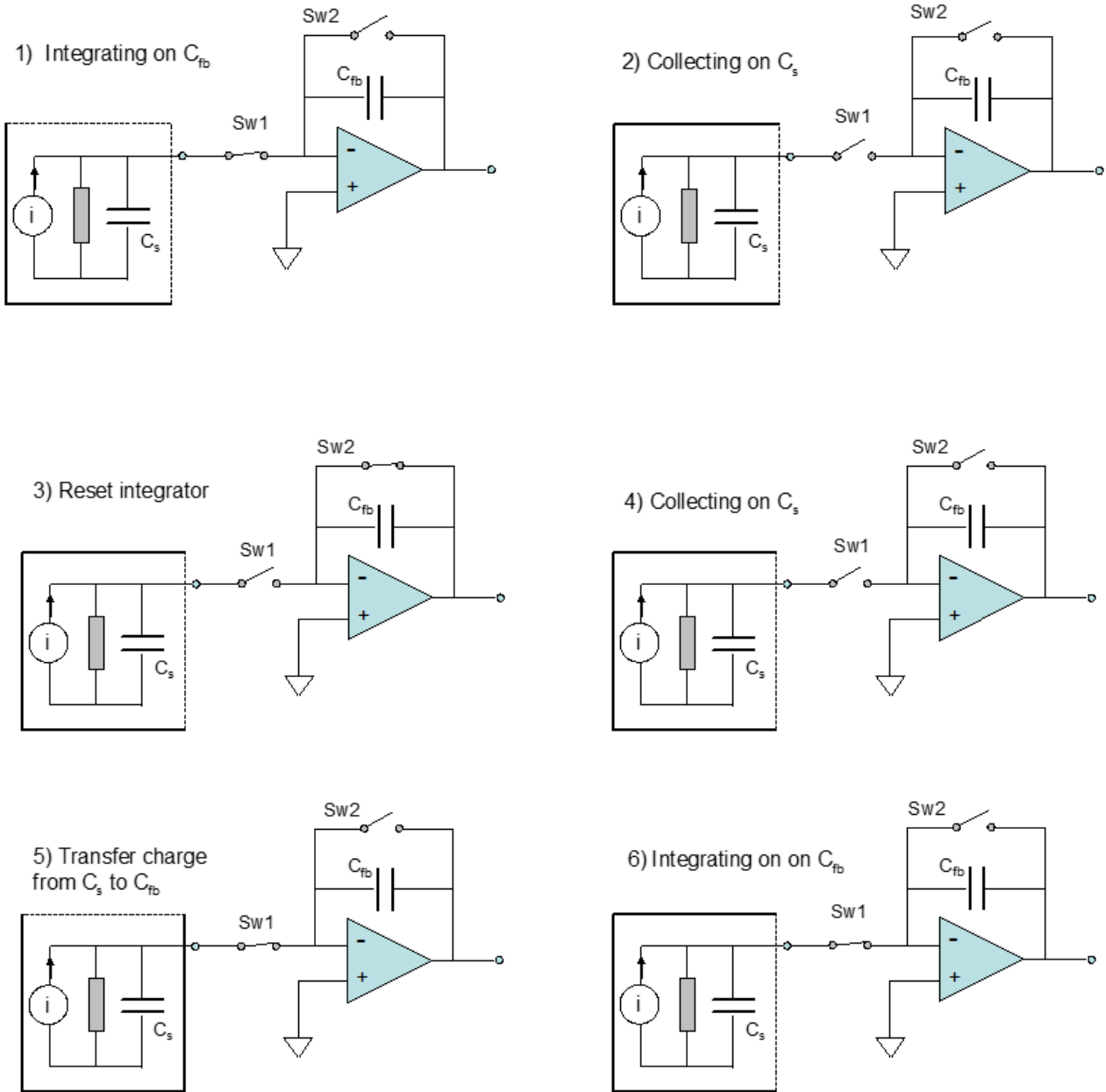

57: Switching sequence for the no-charge loss method.

Consider the integrator working normally, with charge accumulating on C_{fb} , and thus voltage increasing at the output (1). The mode 2 no charge loss reset cycle starts by opening the input switch Sw1 (2). If the load parallel resistance is high, the only place that the source current can now go is to build up charge on C_s . The integrator is now reset (3) by closing Sw1; charge continues to accumulate on C_s (4). When Sw1 closes again, the accumulated charge transfers quickly to C_{fb} . This is because the effective input capacitance of the integrator is much greater than C_s due to the amplifier action (5). The integrator output voltage jumps upward as a result of the transferred charge. Assuming lossless transfer, the net result is to extend the integration time over the complete reset cycle, so that all of the incoming charge is measured. The integration now proceeds normally again (6).

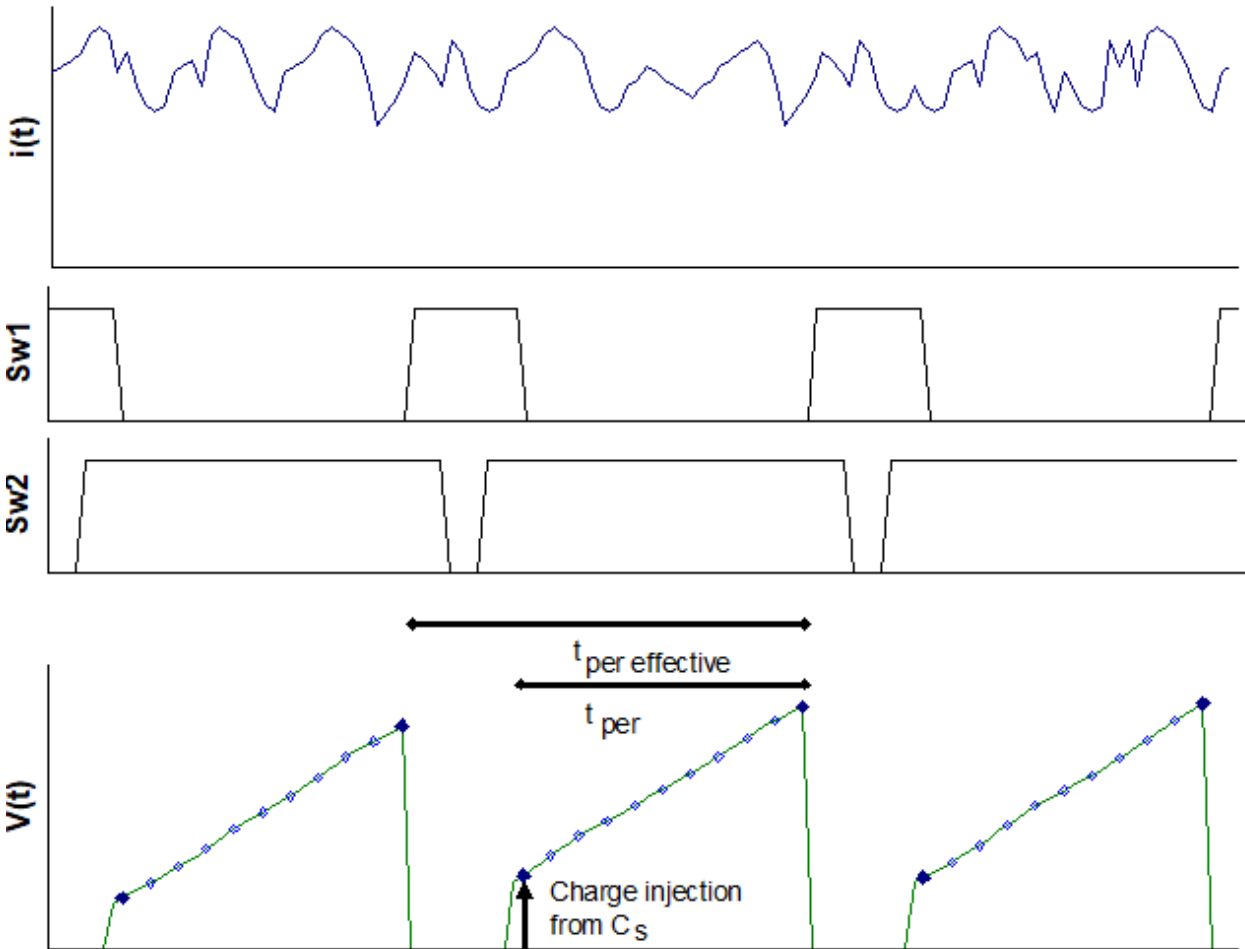

58 : No lost charge timing diagram. The integration period t_{per} is effectively extended over the complete integration cycle.

14.5 Time Resolved Measurements

14.5.1 Standard Mode and FastMode

The I3200 can operate in two data transfer modes according to the type of host system it is communicating with.

Standard mode

The I3200 generates readings at the rate dictated by the integration time, subsample count and reset parameters. The host system collects these readings at the rate allowed by the host software and the communications link. Any readings which are not collected before the next reading overwrites them are lost.

Standard mode communications can be by ASCII or binary messages, with binary more efficient and thus faster. The readings are translated to coulombs by the I3200 using the stored calibration.

FastMode

FastMode is only available in combination with the Pyramid Technical Consultants, Inc. A500 real-time controller. It is automatically selected with the first initiate command for all running modes *except* all accumulation modes, gated trigger mode, and message trigger mode. If you are using the PSI Diagnostic host software, there is a LED display on the Data tab which shows that FastMode is in use. FastMode permits use of integration periods and subsample periods down to 20 μ sec.

FastMode communications are in the form of raw 16-bit data. The application of the calibration and translation to physical units is performed by the A500.

Two layers of buffering are available in fast mode. The I3200 on-board memory can store up to 250 readings. These are guaranteed to be contiguous, even at the shortest integration and subsample periods. The A500 can store up to 64,000 readings. These will be contiguous if the communications between the I3200 and the A500 can keep up with the data generation rate.

Clearly FastMode is required for the best time-resolved reading capability. It is particularly suited to capturing a sequence of readings across a single-shot event such as a short beam pulse. If the I3200 is reading out a position encoder such as an electrode array, then the resulting dataset will be a spatial and time-resolved picture of the event.

Note that the ability to take time-resolved data is limited ultimately by signal to noise ratio, and the frequency components of the noise. At short integration or sub-sample periods, lower frequency noise components are not averaged, so you may end up with nothing more than good time-resolved noise if there is insufficient signal and / or your noise levels are high.

14.5.2 Example of time-resolved data

An example will illustrate how spatial and time resolved data can be obtained. For the example, a resistive divider circuit was used to produce a triangular pattern of currents across the 32 channels of an I3200 connected to an A500. A 200 μ sec long pulse waveform (figure 60) was used to drive the divider circuit.

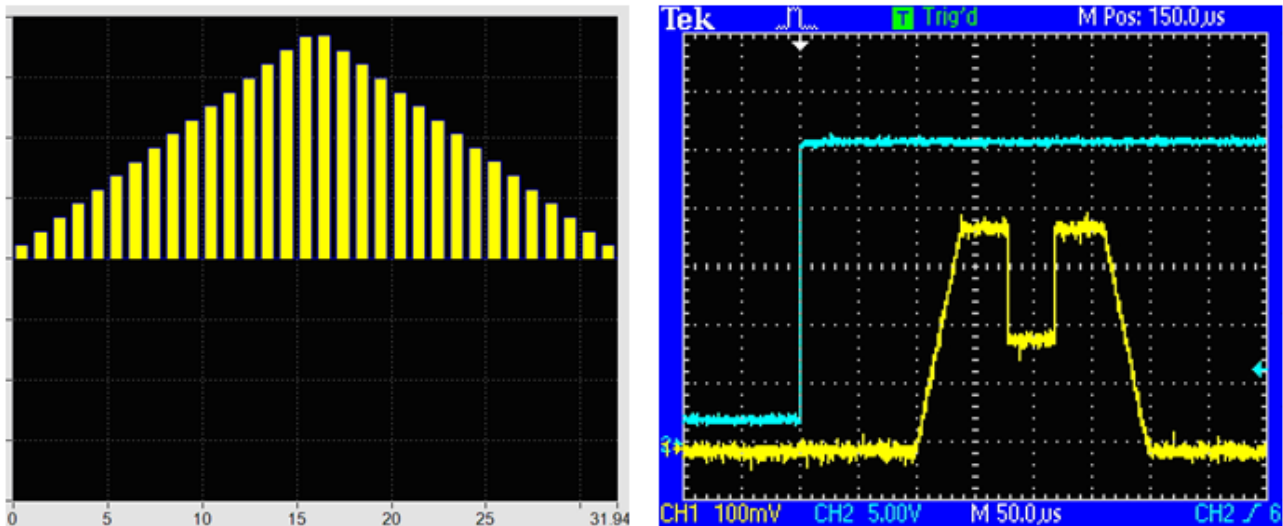

59 : Channel current distribution (left) and pulse waveform input (right,yellow trace)

The I3200 was set up to integrate for 400 μ sec with 20 subsamples, so that each subsample was 20 μ sec long, the minimum. The data recovered for a single shot is shown as a function of time below. Time resolved signals from all 32 channels.

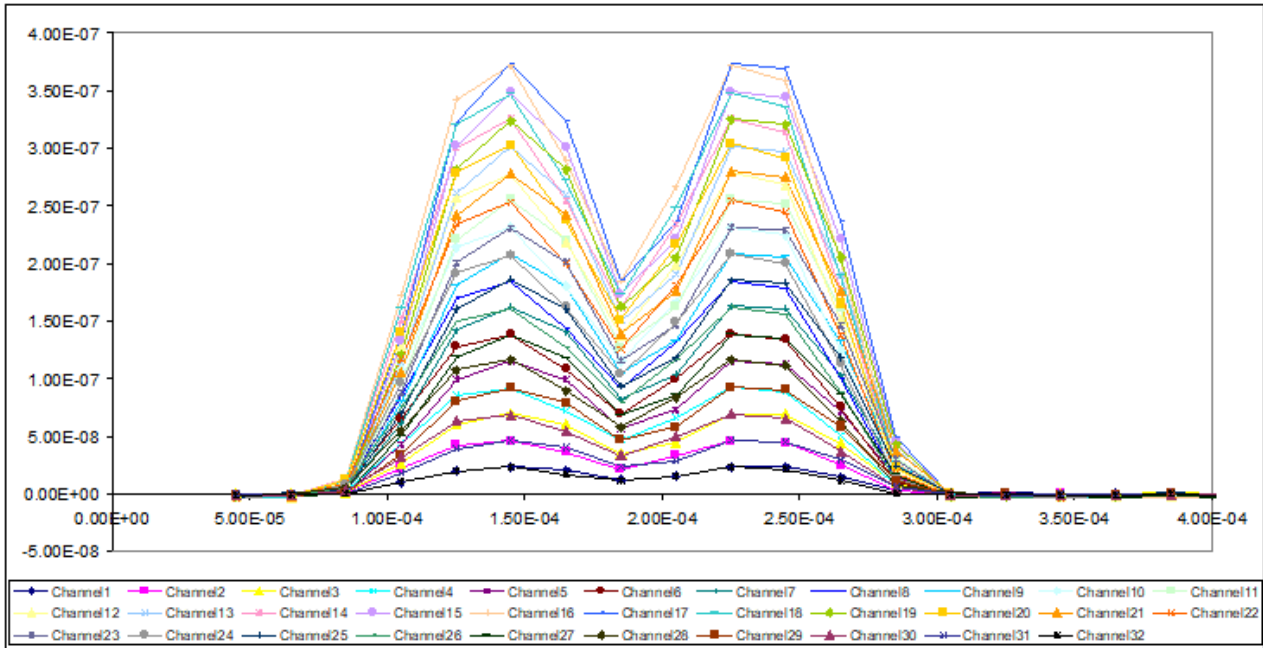

60 : Time resolved signals from all 32 channels.

The figure below shows some spatial snapshots at different times. Note that the effect of the small time offset between the odd and even channel ADC conversions can be seen when the signal is changing rapidly with time. This effect is only really significant for the shortest available subsample periods.

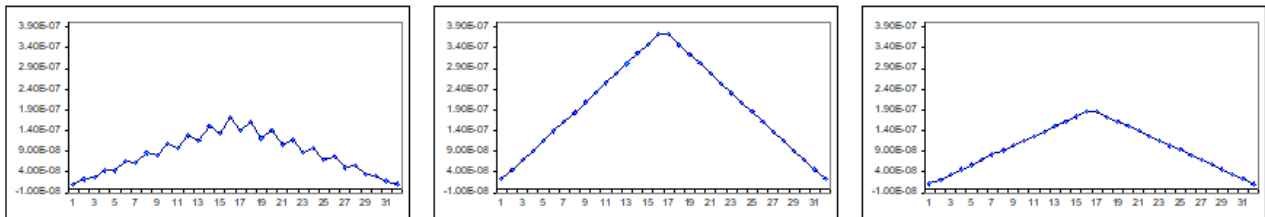

61 : Snapshot spatial profiles at 1.05e-4 s, 1.45e-4 s, and 1.85e-4 s after the incoming trigger start

14.5.3 Recovering time resolution from the raw data

The data delivered by the I3200 for each channel when sub-sampling is in use is the charge integrated up to each particular sub-sample ADC conversion, plus the total integration time up to that conversion. For example, if we take N sub-sample readings per integration period at times t1, t2, t3 ... tN, with the initial conversion having been done at t0, the data for one channel with input signal i(t) will be:

Time	Charge	Integration Period
t1	q1 =	(t1 - t0) = t _{sub}
t2	q2 =	(t2 - t0) = 2t _{sub}
t3	q3 =	(t3 - t0) = 3t _{sub}
..
tN	qN =	(tN - t0) = 5t _{sub} = t _{per}

To see the 20 μsec time resolution across the whole integration period, the host software needs to process the data to remove the progressive integration, as follows.

Time	Charge in sub-sample	Integration Period
$(t_1 - t_{sub}/2)$	q_1	t_{sub}
$(t_2 - t_{sub}/2)$	$(q_2 - q_1)$	t_{sub}
$(t_3 - t_{sub}/2)$	$(q_3 - q_2)$	t_{sub}
..
$(t_N - t_{sub}/2)$	$(q_N - q_{N-1})$	t_{sub}

Figure 63 illustrates recovery of an AC component from the sub-sample data by this means. Notice that the reconstructed data is somewhat distorted in this example because the integrator voltages corresponding to $q_1, q_2...$ are made deliberately small in the example. This can occur in practice when you are constrained in your choice of integration period. The constraint may arise because the signals you want to measure are only present for a limited time, for example the “on” time of a pulsed beam system. There is no benefit in having the integration much longer than the signal pulse, for example, as you will only be integrating noise and degrading the signal to noise ratio.

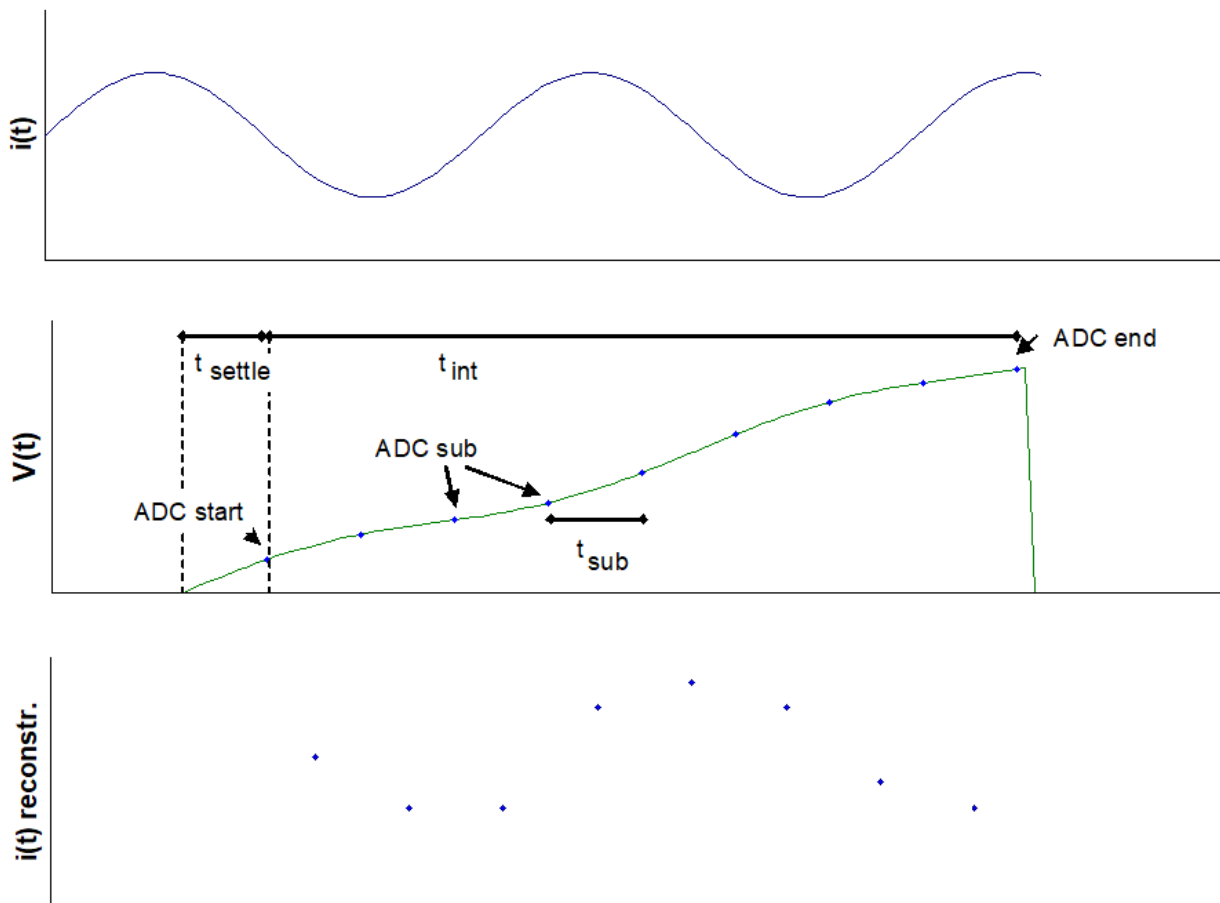

62 : Input current, integrator output voltage with ADC conversion points, and reconstructed current waveform.

14.5.4 Low pass filtering due to input impedance

The input to the I3200 can be represented as a capacitance to ground, due to the detector electrode and input cabling, and a series resistance which is the input impedance of the unit.

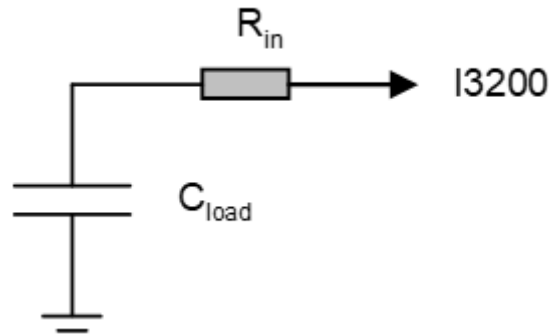

63 : Low pass filter formed from load capacitance and input impedance

The time constant of this low pass filter is $R_{in}C_{load}$ seconds. The load capacitance may be up to 1000 pF. Coaxial cable is a major contributor, with typical capacitance of about 100 pF per metre. If no additional input resistance is fitted to the I3200, the input resistance is approximately 2 kohm. The low pass roll-off point when this is combined with 1000 pF of load capacitance is 2 μ sec, which is short compared to the minimum time slice of 20 μ sec, and can be ignored. If the input resistance is increased to 100 kohm to improve the immunity to voltage noise sources, the time constant becomes 100 μ sec, and the higher frequency components of the signal will be attenuated. In general you should try to keep the load capacitance low to avoid unintended filtering.

14.6 Effect of Cable Capacitance on Measurement Accuracy

You can consider the input behavior of the I3200 integrator circuit as equivalent to a large capacitor with value equal to the feedback capacitor multiplied by the open-loop gain of the amplifier. Although signal cable capacitance is generally considerably lower than this dynamic input capacitance, it can nevertheless have a measureable effect in some circumstances.

The signal current divides between the I3200 dynamic input capacitance and the cable capacitance according to their relative size. If both values were constant, then this would be of no concern, because the calibration would compensate for any given cable load. However, the dynamic input capacitance takes about 50 μ sec to build up to its maximum value after the start of any integration, due to the finite bandwidth of the amplifier. This leads to an inaccurate first ADC reading.

This cable loading effect is only significant for the combination of short integration time, small feedback capacitor and high cable capacitance. It is of no practical concern for integration time of 1 msec or greater, or feedback capacitance of 100 pF or greater.

Figure 66 shows how the I3200 under-reads as a function of cable load for a 10 pF feedback capacitor, and 20 μ sec and 100 μ sec integration time.

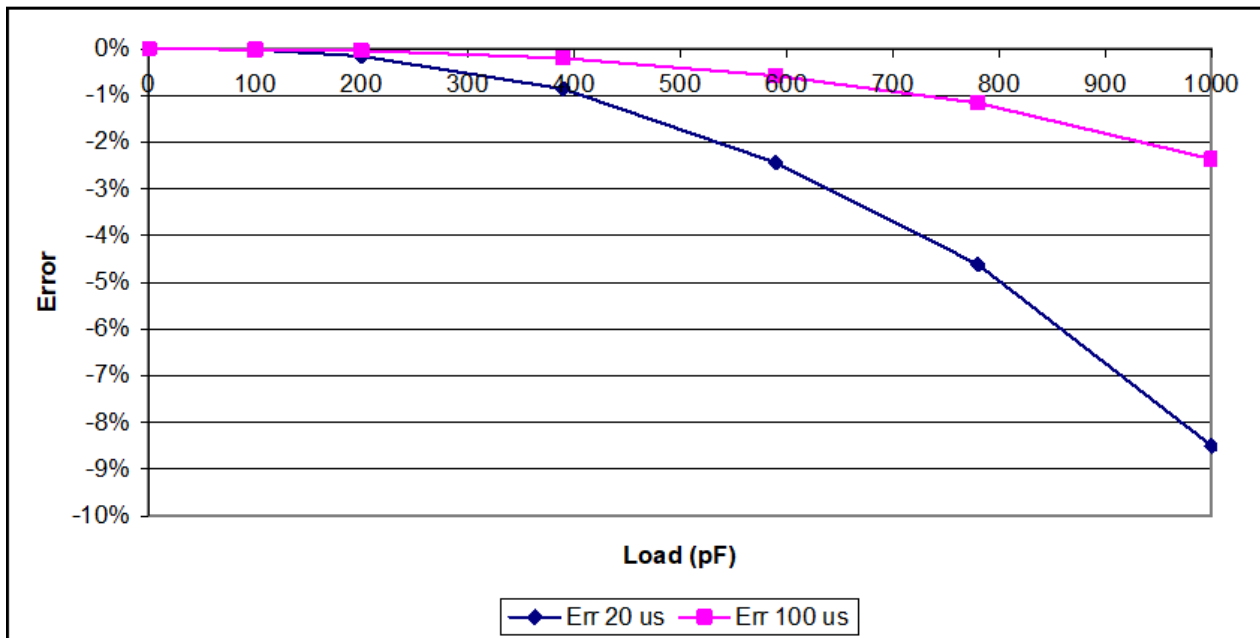
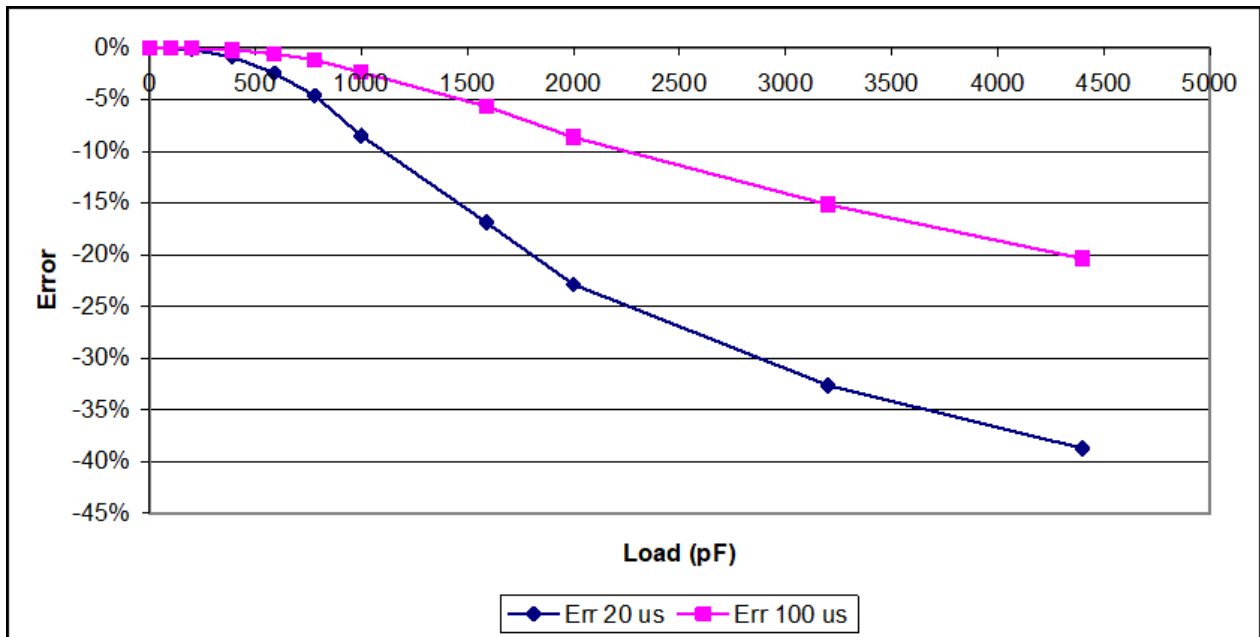

64 : Worst case measurement error due to cable capacitance, 10 pF feedback capacitor and minimum integration times. The lower plot is an expansion of the 0 to 1000 pF part of the upper plot.

We recommend that cable capacitance is limited to a maximum of 750 pF, to limit the error at 100 usec integration to 1 %.

If your application is to measure a beam shape, then the systematic error, which is common across all channels, may be of no concern. If you do need to eliminate the error, and you cannot reduce the cable capacitance, then you should use a larger feedback capacitor and/or longer integration time.

14.7 Data Readout and Buffering

14.7.1 Data readout and buffering in ASCII mode

In ASCII mode, the ADC readings are converted to floating point numbers in coulombs by application of the calibration in the I3200. The value for each channel requires 12 bytes, and the integration time and the overrange byte add to this to give a message size for reading out all 32 channels of about

400 bytes. The maximum data rate to the host is 3 Mbps via USB, and 115 kbps via RS-232, so the transmission time for the data is in the range 1 to 10's of milliseconds. The data rate will generally be less than this implies, because the host must send messages, and there may be other devices if you are using a loop topology.

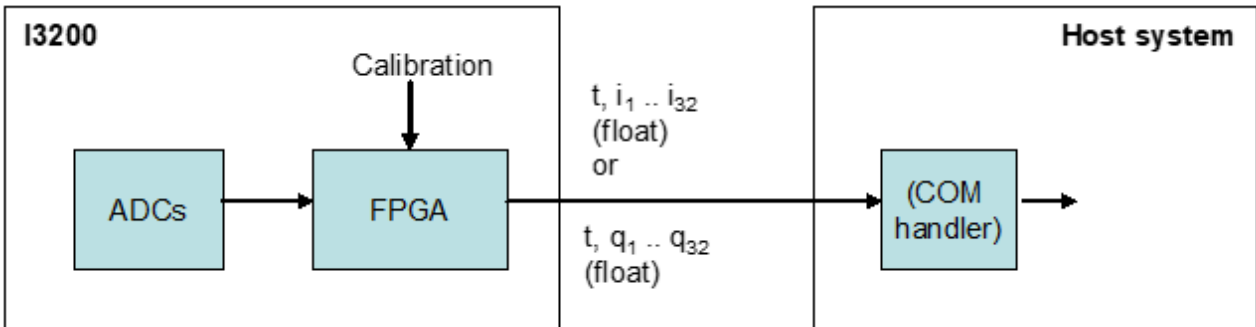

65 : Dataflow in ASCII mode

If data is generated by the I3200 at a higher rate than the maximum available transmission rate, then samples that cannot be transmitted are discarded. Because each 32-channel sample is given a sequential index number corresponding to each trigger, you can see if any samples have been lost by examining the data. In the basic application of monitoring a slowly varying current with random noise components, such missing data is of little consequence. However if you are attempting to capture a transient event, then this is likely to be unacceptable, and you should use a higher bandwidth communication protocol and interface.

14.7.2 Data readout and buffering in binary mode

Binary mode provides higher performance, especially when the I3200 is connected to a real-time controller such as the A500. Each channel requires four bytes which represent the charge value, and the maximum communication speed using the fiber-optic loop is 10 Mbps, so data rates can be 5 to 10 times faster than the best that can be achieved in ASCII mode. Values are sent up to the host as they are generated.

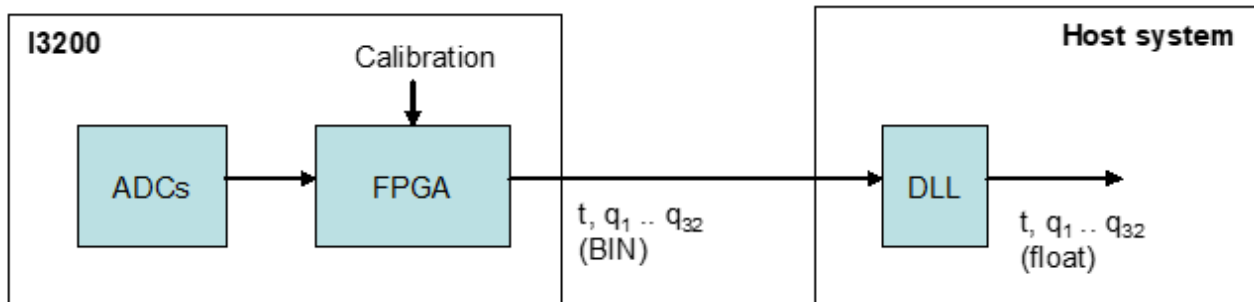

66 : Dataflow in binary mode without A500.

The A500 has the capability to buffer a sequence of 64,000 values. Depending upon the loading of the communication channel, the integration period may be as short as 200 μsec with no lost data.

14.7.3 Data readout and buffering in A500 FastMode

In FastMode the translation to coulombs is performed by the A500, using the calibration data uploaded from the I3200. This process is transparent to the host computer. In this mode it is also possible to buffer up to 250 samples in the I3200 itself, which allows contiguous sub-sampled data with periods down to 20 μsec. This is the highest available time resolution, and can be used with a position-sensitive detector for example, and given adequate signal to noise ratio, to produce a time and spatially-resolved analysis of a transient event such as a beam pulse. The A500 can also buffer up to 64,000 samples in its own memory, which may be contiguous data if the data transfer rate from I3200 to A500 is greater than the rate at which data is generated by the I3200.

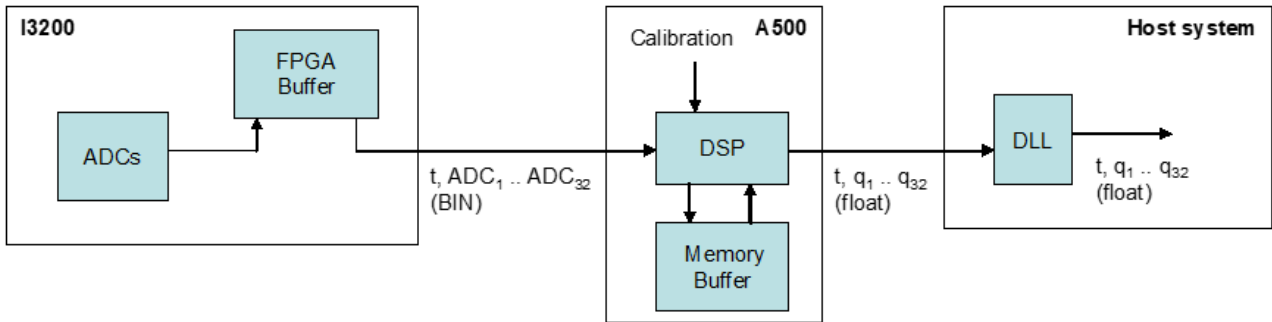

67 : Figure 69. Dataflow in fast binary mode with A500.

14.8 Triggering

14.8.1 Trigger sources

Every measurement made by the I3200, whether a subsample or full integration period reading, is a response to a trigger. You preset all the relevant parameters such as feedback capacitor, integration period, number of sub-samples, PGA setting and type and number of triggers. Then initiate the measurement. The measurement only starts however when an initiating event is detected. There are several initiation sources and modes:

Internal	Auto-run. Triggers are generated internally by the I3200 once the “initiate” message is received. Triggers continue to be generated until the defined number of triggers is reached, or the “abort” message is received.
ExternalStart	A high (low) level on the gate input starts a predefined acquisition sequence. The I3200 continues to respond to the triggers until the defined number of triggers is reached, or the “abort” message is received.
ExternalStartStop	A high (low) level on the gate input starts a predefined acquisition sequence. The sequence continues until either the programmed number of integrations is complete, or the gate input falls (rises) again, in which case the sequence terminates after the integration in progress. The I3200 continues to respond to the triggers until the defined number of triggers is reached, or the “abort” message is received.
ExternalGated	External gated mode is no longer supported on the I3200.
Message	A special one-byte message on the communication link triggers the predefined acquisition sequence. The I3200 continues to respond to the triggers until the defined number of triggers is reached, or the “abort” message is received. This mode is no longer actively supported.
ExternalStartHold	A high (low) level on the gate input causes the first integration of the predefined sequence. The I3200 then waits in reset for the next high (low) to cause the second integration. This process continues until the defined number of triggers is reached, or the “abort” message is received.

In all cases you can select infinite triggers and the acquisitions will continue indefinitely until you send the abort command or reset the I3200.

The external and gated modes require a physical initiation signal via the gate input BNC or the gate input fiber-optic receiver. The BNC input requires a TTL level, and presents a TTL gate impedance. The fiber-optic input requires an on/off light. Which input to use, and the sense of the logic are a software configurable parameters. Use of these inputs is most appropriate when you require the

minimum (sub-microsecond) and most consistent delay between the incoming initiation signal and the start of integration. If you do not intend to use the optical input, you should fit a cover over it to avoid accidental triggers from ambient light.

Message triggering provides similar performance to the external modes, but with slightly greater delay, and without the additional cabling to the gate inputs. In looped systems, the loop controller knows the position of each device in the loop, and arranges for each device on the loop responding to the trigger to delay its response according to its position in the loop, so that all devices start their acquisitions at the same time.

14.8.2 Illustration of ExternalStart mode

The figure below is a schematic example showing an ExternalStart initiation of a sequence of seven integrations. Each integration includes three sub-samples, for a total trigger count of 21. The process starts when a high level is detected on the gate input. A similar sequence could be started by a message trigger.

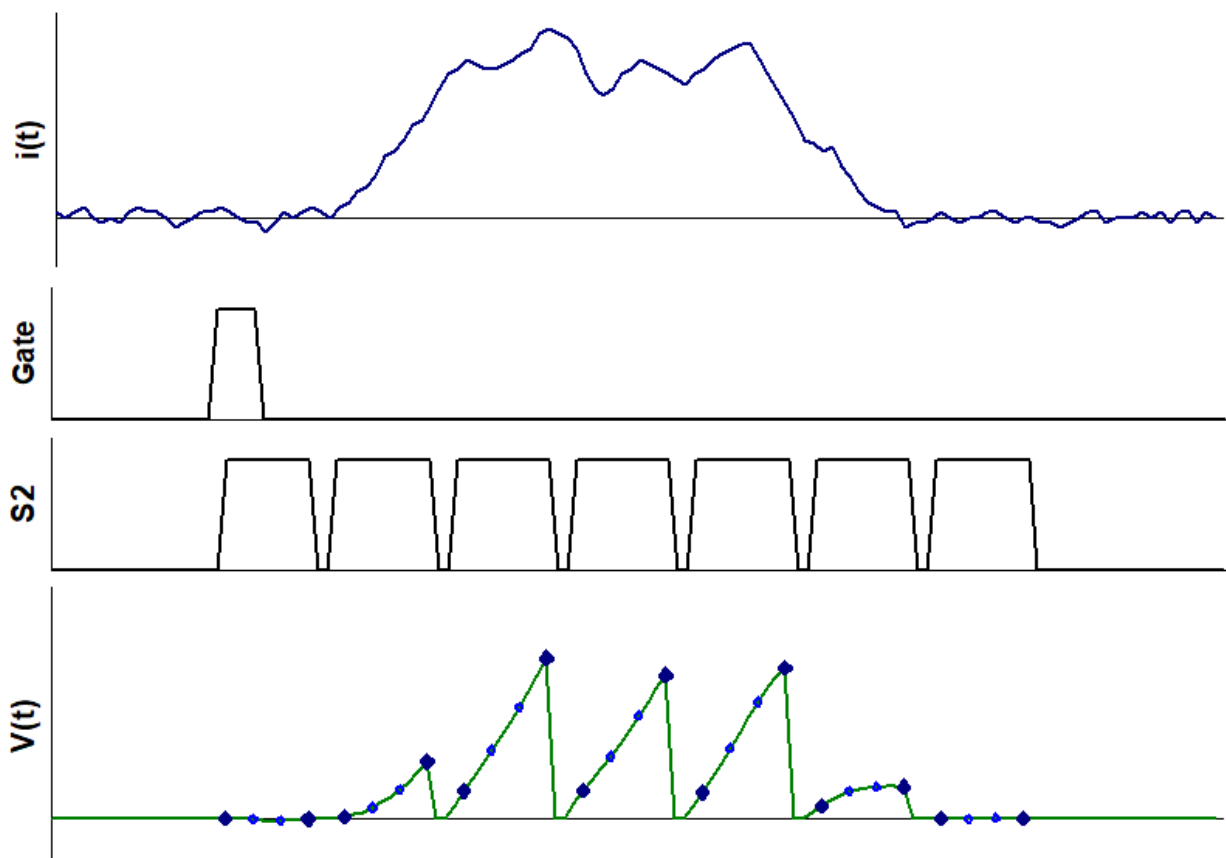

68 : Example of an "external start" triggered measurement sequence started by a rising edge

14.8.3 Illustration of ExternalStartStop mode

The figure below shows an ExternalStartStop trigger example. The sequence starts when the gate is detected high as in the previous example. However in this case the I3200 is also sensitive to the going low while the acquisition is in progress. When the gate line falls again, the sequence terminates after the integration in progress.

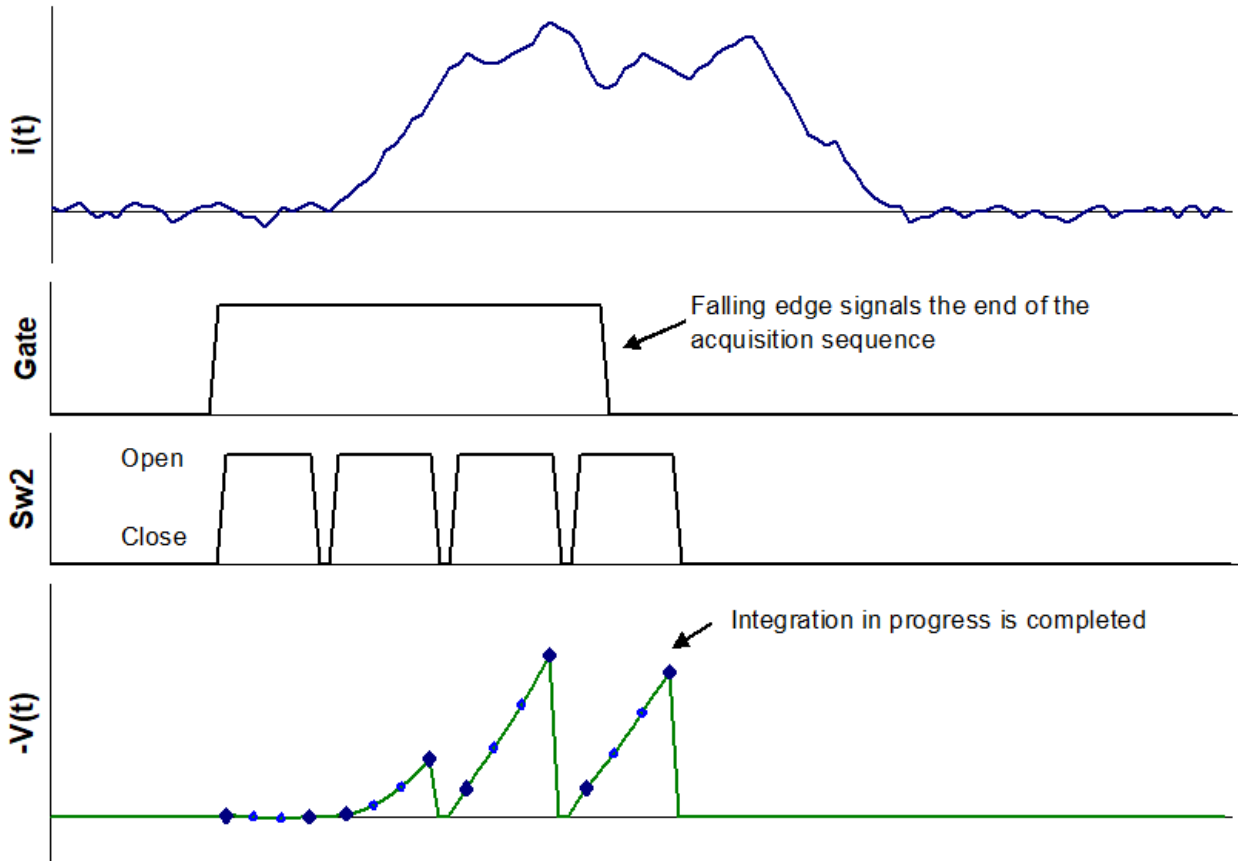

69 : Example of an "ExternalStartStop" triggered measurement sequence started by a high state on the gate and ended by a low state.

14.8.4 Illustration of ExternalStartHold mode

The figure below shows an ExternalStartHold trigger example. The state of the gate input now directly determines when the next integration will occur.

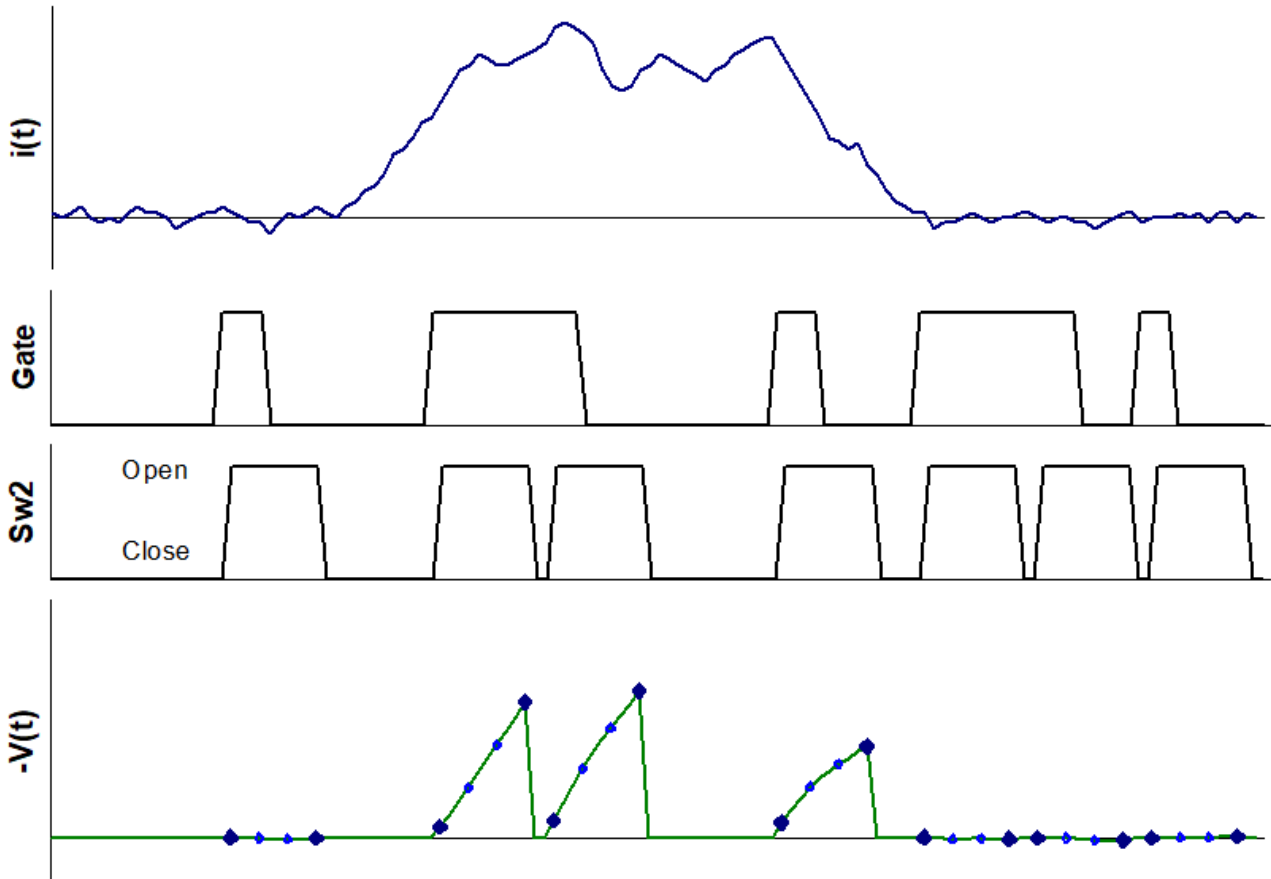

70 : Example of an “ExternalStartHold” triggered measurement sequence with each individual integration started by a high state on the gate.

14.9 Background offsets

Consider an integration cycle as shown in the figure below. The voltage presented to the (ideal) ADC comprises the integrated signal, $V_{\text{signal_voltage}}$, the integral of any net background offset current, $V_{\text{bdg_current}}$, and a voltage pedestal, V_{offset} , due to amplifier offsets and the offset of the ADC itself. In practice these unwanted offsets will be much smaller than the signal, and may be negative or positive relative to the signal, but they must nevertheless be managed correctly to get maximum accuracy at the lowest currents and charges.

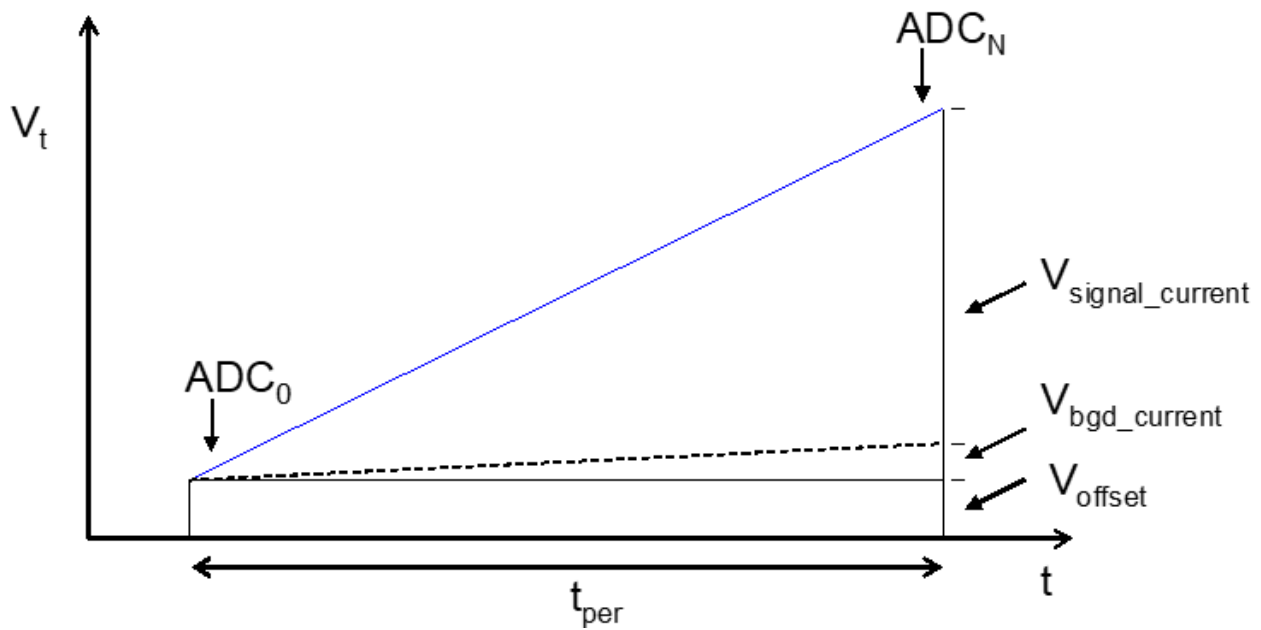

71 : An integration showing signal and noise contributions to the final output.

V_{offset} is eliminated automatically by the operation of the I3200, because the charge is measured as $k(ADC_N - ADC_0)$, so the offset cancels.

Background current is not eliminated automatically, because it is indistinguishable from signal current at any moment in time. The I3200 internal background current is small (pA level) and stable. The background from the external circuit will generally be higher, but depends greatly on the particular sensor or transducer.

Depending upon your measurement needs, it may be appropriate to subtract the total background current if it is significant relative to the signal, and relatively stable. You should be careful of changes to the background which would render any such correction invalid, however. This could be due to changes in temperature or electrical noise.

Background nulling can be automated in the host software. The background should be measured with a long integration period, sufficient to get an accurate value, and with no true signal present, only the background current. The resulting background current values, i_{bgd} , for each channel can be subtracted from subsequent current readings, either manually or in host software. In charge measurement modes, subtract $(i_{bgd} \times t_{per})$.

15 High Voltage Supply

15.1 Setting the High Voltage Supply

The I3200 is available with a one-watt high voltage supply suitable for biasing ionization chambers, diodes, and proportional chambers. The voltage range can be specified at time of purchase from 200, 500, 1000 and 2000V with either polarity.

Any valid setpoint above zero volts enables the relevant supply. The HV on LED illuminates when either or both supplies are enabled. The set value can be adjusted at any time, independent of what measurements are in progress. You may see a signal as the voltage charges the capacitance of the external circuit.

The supply is limited by a software high voltage limit, which is password protected and stored in EEPROM in the I3200. The I3200 will reject any attempts to set the voltage higher than the limit. This allows sensitive detector systems or experiments which may be damaged by excessive voltage to be protected.

The maximum current compliance of the high voltage power supply depends upon its voltage range and the output voltage it is delivering. Taking the 1000 V supply as an example, at low outputs, the compliance can be represented as the current that the voltage would cause to flow in a resistor of about 300 kohm. Thus up to 100 μ A is available at 30 V output, 200 μ A at 60 V output and so on. At higher outputs it is limited to 1 mA maximum. The low voltage operating region for the 1000V supply is illustrated in figure 74. The other supply options have greater or lesser current compliance according to their voltage rating, but a similar relative behavior.

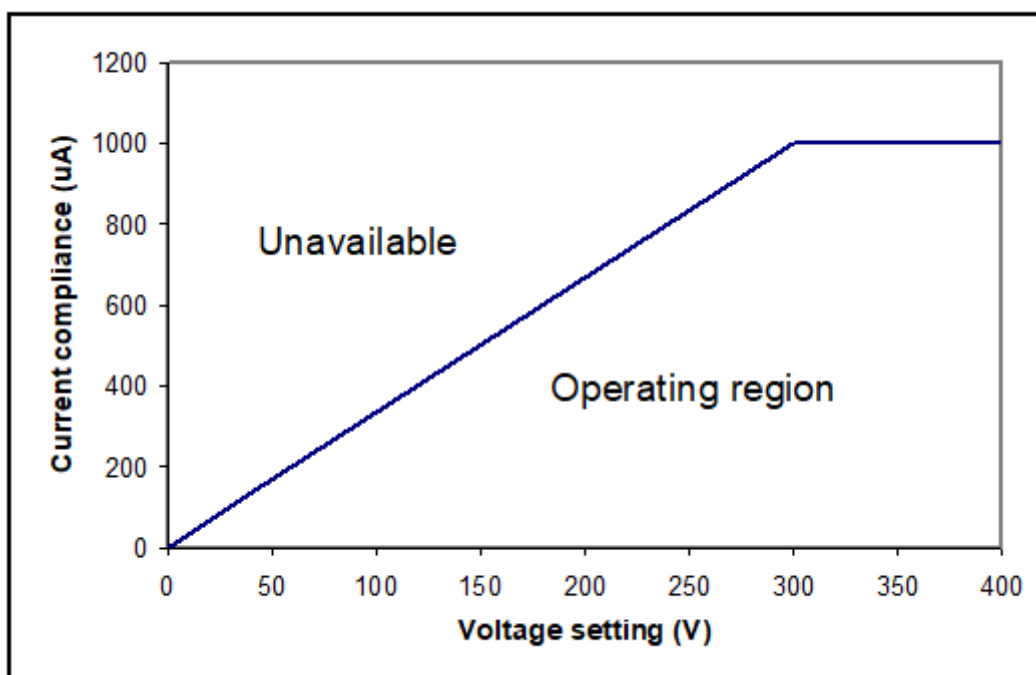

72 : Current compliance of the 1000V high voltage supply.













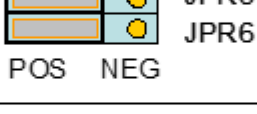

A voltage divider on the HV output senses the actual voltage being delivered. If this value differs significantly from the setpoint, you know that the output is either being loaded down by a low resistance to ground, or that it is being driven by another source of higher compliance. A vacuum chamber with a large free electron population can load down a positive power supply connected to an electrode in that chamber. A charged particle beam striking the electrode connected to the HV supply can have this effect. In all cases you should investigate the cause, because damage may result to the I3200.

Positive supplies source conventional current, and negative supplies sink conventional current. A bleed resistor fixed load is connected to each high voltage supply output which drains 40 μA at maximum voltage. Transorb protection devices prevent the absolute value voltage at the output going more than 80 V above the maximum rating. However these devices are not designed to pass large currents indefinitely, so you should be careful not to overdrive the outputs with other power supplies or with charged particle beam strike currents.

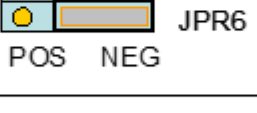
! **CAUTION:** Do not connect external power supplies to the I3200 external high voltage output that will drive the built-in supplies away from the voltages they are trying to regulate, or you may cause damage to the I3200.

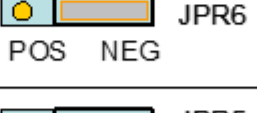
15.2 Changing the High Voltage Supply Range and Polarity

The range and polarity of the high voltage supplies is fixed and must be specified at time of purchase. Units may be returned to the factory to alter the high voltage modules if necessary. It not recommended that users change the high voltage supply module, but the necessary configuration details are given here for reference.

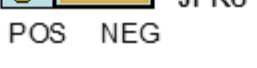
HV Module	JPR 1 setting	JPR 5 & 6 setting
+200 V	 HVE	 JPR5 JPR6 POS NEG
+500 V	 HVE	 JPR5 JPR6 POS NEG
+1000 V	 HVE	 JPR5 JPR6 POS NEG
+2000 V	 HVE	 JPR5 JPR6 POS NEG
-200 V	 HVE	 JPR5 JPR6 POS NEG
-500 V	 HVE	 JPR5 JPR6 POS NEG
-1000 V	 HVE	 JPR5 JPR6 POS NEG
-2000 V	 HVE	 JPR5 JPR6 POS NEG

73 : Jumper settings for high voltage options.

16 Using the Actuator Control Connector

Many detector devices are mounted on motion actuator systems so that they can be moved in and out of the path of a beam of charged particles or ionizing radiation. The I3200 provides an auxiliary input / output connector on the front panel intended for control of a pneumatic actuator, but also available for other purposes.

Switched +24 VDC power is available to drive a solenoid, relay or similar device. The output is protected by a 1 A automatically resetting fuse. You should remember that the current drawn from this output is in addition to the load of the I3200 itself on the +24 VDC power input.

Two opto-isolated digital inputs are provided for limit switch sensing or general applications. The switch +5 VDC continuity test signal is also routed to this connector in parallel to the signal input connectors. Figure 76 shows a typical arrangement for pneumatic actuator control.

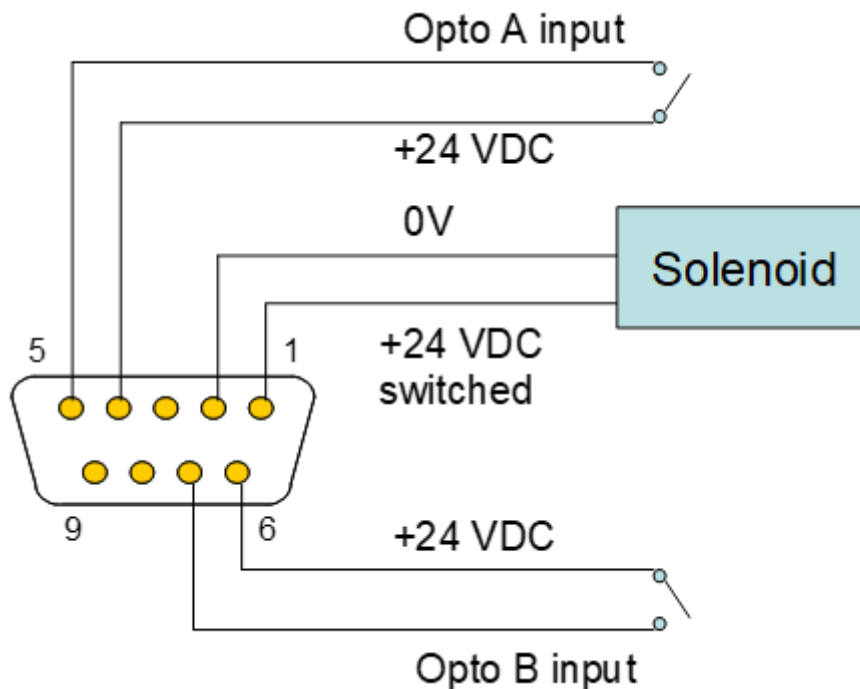

74 : Connecting a solenoid-operated actuator to the actuator control connector.

- Note that if actuator movement causes flexing of the signal cables connected to the I3200, then triboelectric noise can be generated and it may be several minutes before background levels are restored. Special low-noise cable is available which reduces this problem greatly.

17 EPICS Interfacing

17.1 What is EPICS?

The Experimental Physics and Industrial Control System (EPICS, <http://www.aps.anl.gov/epics/>) is:

“A set of Open Source software tools, libraries and applications developed collaboratively and used worldwide to create distributed soft real-time control systems for scientific instruments such as particle accelerators, telescopes and other large scientific experiments. EPICS uses Client/Server and Publish/Subscribe techniques to communicate between the various computers. Most servers (called Input/Output Controllers or IOCs) perform real-world I/O and local control tasks, and publish this information to clients using the Channel Access (CA) network protocol. CA is specially designed for the kind of high bandwidth, soft real-time networking applications that EPICS is used for, and is one reason why it can be used to build a control system comprising hundreds of computers.”

Pyramid supplies an executable called IG2 which embeds an open source Channel Access Server from the EPICS community. This allows connection via the Ethernet interface. IG2 is configured for the devices you wish to connect using editable xml files. Once IG2 is running on a computer in your network, then any other computer can run a client program which can display and control the process variables for the devices. In the simple network in figure 77, the process variables of a I3200 an M10 and H20 attached to an A360 loop controller via fiber optics, are exposed to the network by the IG2 service running on a server computer. One or more client GUI computers can then access the values.

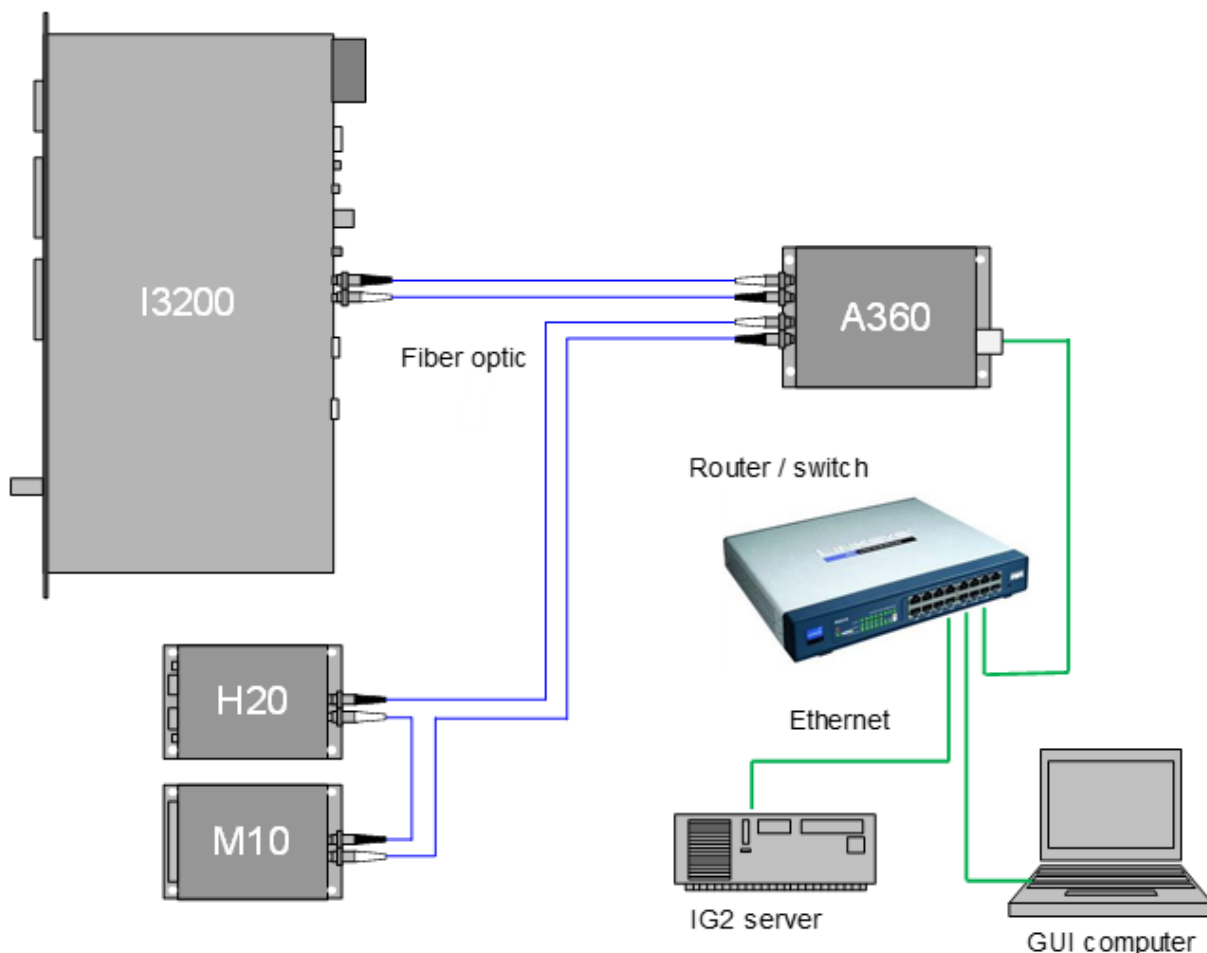

75 : Simple example network for EPICS communications.

There are a wide range of client interfaces from the EPICS community, including interfaces for C++, C#, Java, Python, and Matlab™. The Control System Studio, or CS Studio, (<http://controlsystemstudio.github.io/>) is a set of ready-made tools built on Java and Eclipse (<http://>

www.eclipse.org/) that allows users to get started with little or no programming required. There are various logging, plotting, post-processing and alarm point tools. A fully-featured “drag and drop” user interface editor (BOY) allows quite complex customized user interfaces to be created with minimum development time.

17.2 Installing and Configuring IG2

The IG2 package is available to users of Pyramid products. It is supplied as a zip file which should be de-compressed and the entire folder moved to the computer that will act as the server. The server and the user interface computer can be the same machine. The loop controller connecting the I3200, the server and the user interface computer should be able to communicate with each other over your network.

IG2 looks for the file `system.xml` in the `\service` subdirectory to establish the configuration of the system. You can locate `system.xml` elsewhere than the default location, or give it a different name, in which case you need to specify the name and path by means of an argument in the command line that launches IG2. The `system.xml` file includes all the information about your setup, including all the process variables that you want to expose, and what you want to call them. Since the names must be unique, it is a good idea to include the device name and the process variable description in the name.

The system file comprises a header section on the xml schema, which does not need to change. Then comes a description of the user interface host computer, descriptions of the fiber optic loop controller devices in your system and descriptions of the devices attached to loops. You don't have to describe every device and every input/output point that is present in your system, but only the ones that you expose in the system file will be visible to EPICS. The following `system.xml` illustrates a simple example for connecting an I3200 with address 9 on loop 1 of an A360 loop controller.

```

1  <?xml version="1.0" encoding="iso-8859-1"??>
2
3  <system
4      xmlns="http://www.ptcusa.com"
5      xmlns:xsi="http://www.w3.org/2001/XMLSchema-instance"
6      xsi:schemaLocation="http://www.ptcusa.com A510.xsd" type="pyramid" >
7
8      <hosts>
9          <!-- NOTE: the ip address does not matter for bcs, but may be required to be present -->
10         <host ip="192.168.100.77" name="PTC" localhost="true" />
11     </hosts>
12
13     <loopcontrollers>
14
15         <loopcontroller name="A360_1" type="A360" ip="192.168.100.68" >
16             <loops>
17                 <loop name="A360_1" number="1" >
18                     <boards>
19                         <board name="I3200_1" type="I3200" address="9">
20                             <channels>
21                                 <channel name="c_I3200_1_initiate" wire="digital_out_initiate" />
22                                 <channel name="c_I3200_1_capacitor" wire="int_out_capacitor" />
23                                 <channel name="c_I3200_1_trigger_start" wire="int_out_trigger_start" />
24                                 <channel name="c_I3200_1_trigger_points" wire="int_out_trigger_points" />
25                                 <channel name="c_I3200_1_integration_period" wire="analog_out_period" />
26                                 <channel name="r_I3200_1_trigger_points" wire="int_in_trigger_points" />
27                                 <channel name="r_I3200_1_currents" wire="variant_in_current" />
28                                 <channel name="r_I3200_1_measuring" wire="digital_in_measuring" />
29                                 <channel name="c_I3200_1_external_bias" wire="analog_out_bias" />
30                                 <channel name="r_I3200_1_external_bias" wire="analog_in_bias" />
31                                 <channel name="c_I3200_1_actuator" wire="digital_out_actuator" />
32                                 <channel name="r_I3200_1_actuator_in" wire="digital_in_actuator_limitA" />
33                                 <channel name="r_I3200_1_actuator_out" wire="digital_in_actuator_limitB" />
34                             </channels>
35                         </board>
36                     </boards>
37                 </loop>
38             </loops>
39         </loopcontroller>
40
41     </loopcontrollers>
42
43     <interpreter>
44         <devices>
45             <epicscas type="epicscas" name="epics_server" monitorOnlyChange="true"/>
46         </devices>
47     </interpreter>
48
49 </system>
50

```

76: System.xml example

The convention of “wires” for Pyramid device process variables, and the fixed names of those wires for each supported product, are described in Pyramid document “IG2 User Manual” which is supplied on the USB drive and available on the Pyramid website. The document also describes how you can scale the values, for example to convert voltages from general purpose I/O devices to physical units relevant to the item they are controlling, and how you can set up monitoring against tolerance bands.

The choice of a corresponding working name for each wire is up to the user; you may wish to choose something descriptive that is relevant to what you are measuring or controlling. We nevertheless recommend a naming convention that makes it clear whether a value is a readback or control (the prefixes `c_` and `r_` are used in the example), which particular device the value is associated with, and a number or letter to indicate the channel for multichannel devices.

18 Dose Control Option

The I3200 dose control option allows the I3200 to control the delivery of a specified amount of dose due to a beam of ionizing radiation. The beam dose to be controlled is represented by the charge accumulated on all 32 channels. The user enters the total charge required. The I3200 asserts a control signal to enable the beam, accumulates the charge until the target is reached at which point the control signal is de-asserted. The total measured delivered charge is recorded, and it is possible to query the value during the dose delivery.

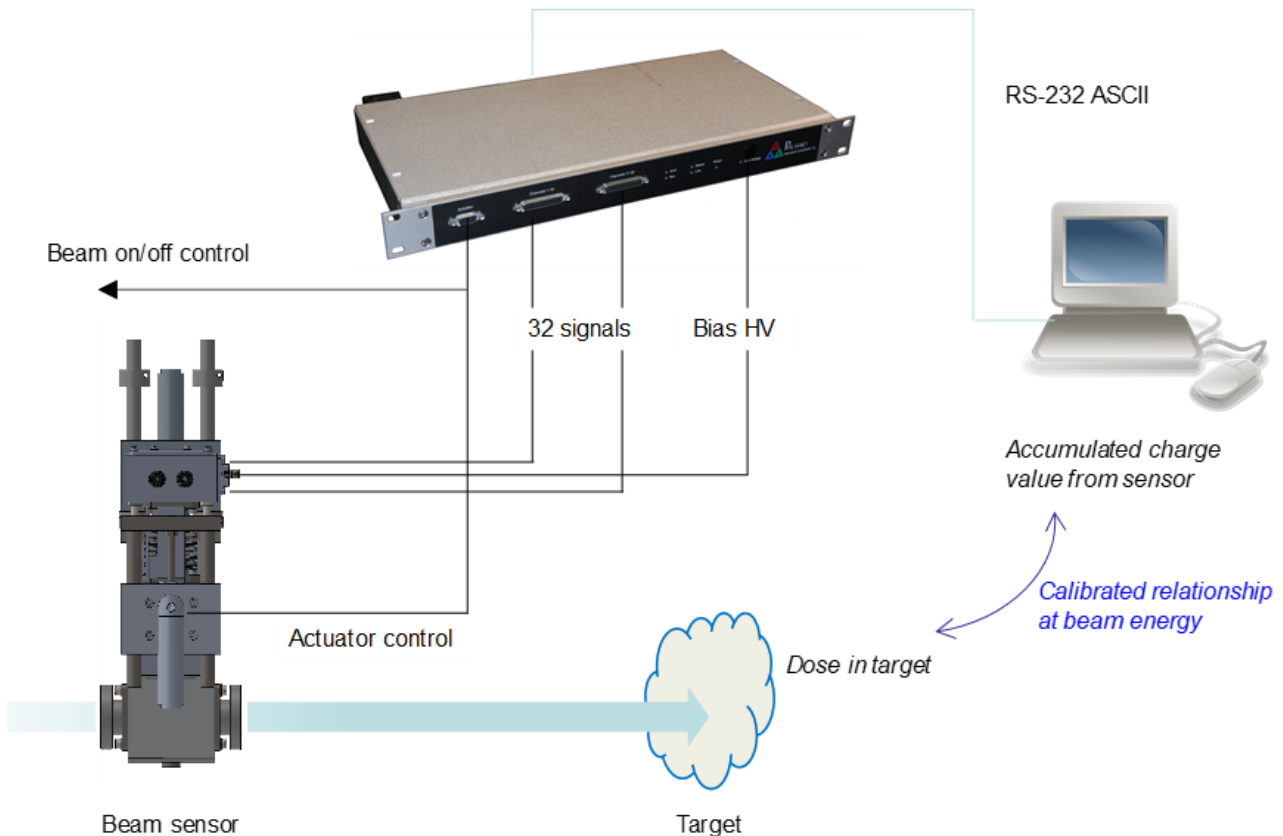

77: Example system for dose control using a BPM16-38 sensor

The configuration and control of this option is only available via the RS-232 ASCII interface for I3200 units with the -DQ option firmware.

⚠ CAUTION: This feature is designed for experimental and research studies. It must not be used for delivery of therapeutic dose to human subjects.

18.1 Overview of operation

When running the dose control code, the I3200 must perform 1 msec integrations, using whichever feedback capacitor is already selected. The 32 channels are summed, and the charge is accumulated and compared to the target. If the 10 pF capacitor is selected (setting 0), the maximum total current is around 90 nA. If the 1000 pF capacitor is selected (setting 1), example, maximum total current is around 9 μ A.

Remember to consider the gain of the detector when relating these measured current ranges to beam current. As an example, a 230 MeV proton beam measured by a BPM16-38 ionization chamber sensor will have physical gain in the chamber of about 160 if both X and Y strips are connected, thus the maximum beam current would be about 1 nA for the 10 pF capacitor and 100 nA for the 1000 pF capacitor. These limits can be doubled if only one half of the chamber is connected.

⚠ CAUTION: The other half 16 electrode strips must be grounded if they are not connected to the I3200 to prevent internal arcing in the BPM.

The relationship between the measured charge and the dose in the target must be established by calibration at all required beam energies.

After setting parameters like bias voltage and feedback capacitor setting, the user sends the target charge value to the I3200 using the RS-232 ASCII interface. The I3200 will immediately set the control signal high (5 V) which should cause the beam to be started. The measured charge on all 32 input channels is accumulated with 1 msec resolution until the target is reached, at which point the control lime is set low again (0 V) which should cause the beam to be turned off.

Charge accumulation is particularly prone to any offset current. A background measurement and subtraction utility allows the offset to be measured before the beam is present, but with all other sources of background present. This offset then subtracted from subsequent charge accumulations.

18.2 Control signal

The 5 V test output is used as the signal out to the beam control. +5 V indicates that the beam should be turned on, 0V indicates the beam should be off.

The signal is most conveniently available on the actuator connector pin 3 relative to pins 8 or 9. If the actuator connector is being used for its usual purpose, then it is necessary to produce a breakout arrangement to expose the control signal.

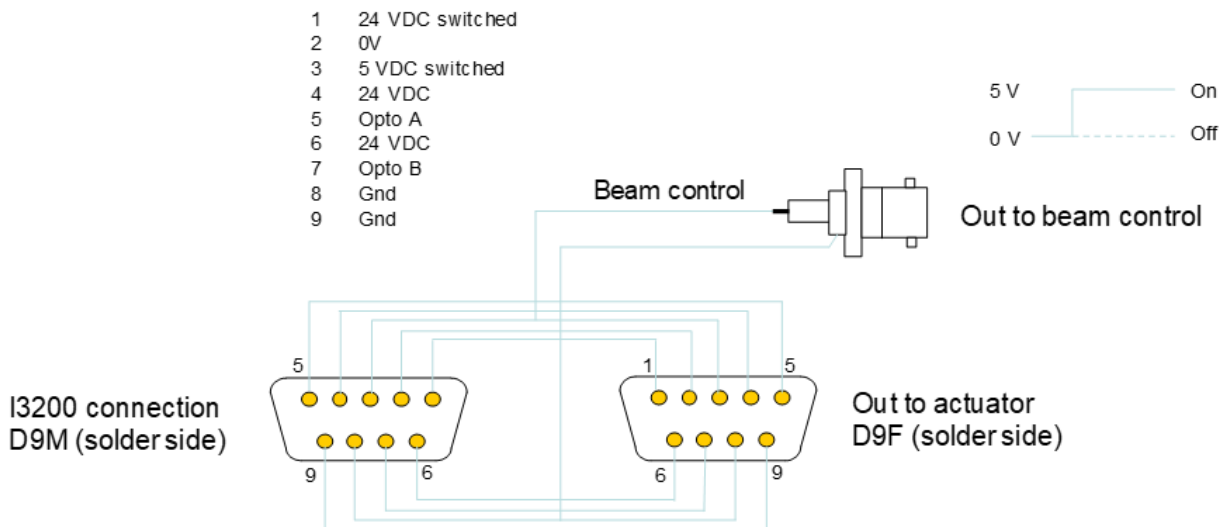

78 : Access to the dose control signal

18.3 Special ASCII commands

The new ASCII commands for dosimetry are:

DOSETARget <value>	Load the target charge value in coulomb and set the 5V control signal high.
DOSETARGET?	Query the loaded dose target.
DOSEVALue?	Query the accumulated charge value.

BACK <0/1>	1: Obtain and store background value by taking average of 100 samples and use for subsequent dose control. 0: Clear the stored background value.
BACK?	Query the background value.

18.4 Example beam control session

The following terminal session demonstrates the operation of the dose control option. A background offset measurement was already made.

```
*idn?
PYRTECHCO,I3200-REV3,0000001646,4.0P/5.3.23{2491}
conf:cap 0
OK
per 0.001
OK
init
OK
dosestar 1e-7
OK
```

Set the 10 pF feedback capacitor

Set 1 msec integration period

Start measurements

Set the target charge and assert the beam on signal

```

doseval?
3.703824e-09{660}
doseval?
5.777872e-09{676}
doseval?
8.327595e-09{672}
doseval?
1.100946e-08{653}
doseval?
1.817589e-08{671}
read?
OK
1.0000e-03 s,-3.2370e-15 C,-9.6780e-15 C,-2.2514e-14 C,0.0000e+00 C,-6.4795e-15 C,-
1.6042e-14 C,-2.4897e-14 C,-1.6029e-14 C,-9.7586e-15 C,6.4832e-15 C,-6.4233e-15 C,-
1.5886e-14 C,-9.6561e-15 C,9.6075e-15 C,-6.4087e-15 C,-1.2830e-14 C{12398},-2.9303e-14
C,0.0000e+00 C,-2.2428e-14 C,3.2187e-15 C,-1.6293e-14 C,-6.4709e-15 C,-6.4014e-15 C,-
1.6084e-14 C,-1.3073e-14 C,0.0000e+00 C,-3.2227e-14 C,-1.2944e-14 C,-9.7668e-15 C,-
1.5717e-14 C,-2.2424e-14 C,9.7813e-13 C,0{11723}
OK
doseval?
3.074320e-08{651}
doseval?
4.229618e-08{664}
doseval?
4.620252e-08{653}
doseval?
5.623312e-08{654}
doseval?
7.576729e-08{675}
doseval?
8.665932e-08{671}
doseval?
9.656351e-08{667}

doseval?
1.000007e-07{639}
doseval?
1.000007e-07{639}

doseval?
1.000007e-07{639}

```

Query the accumulating [charge](#)

Query the instantaneous currents (beam profiles)

Query the accumulating [charge](#)

Query the accumulating charge – target reached – accumulation stopped - control signal has been set to [zero](#)

The control signal went high when the dose target was sent to the I3200, stayed high while the dose was accumulating, then was set low when the target was reached. It is not necessary to query the charge in order for the control signal to go low – this is handled internally by the I3200 at 1 msec resolution.

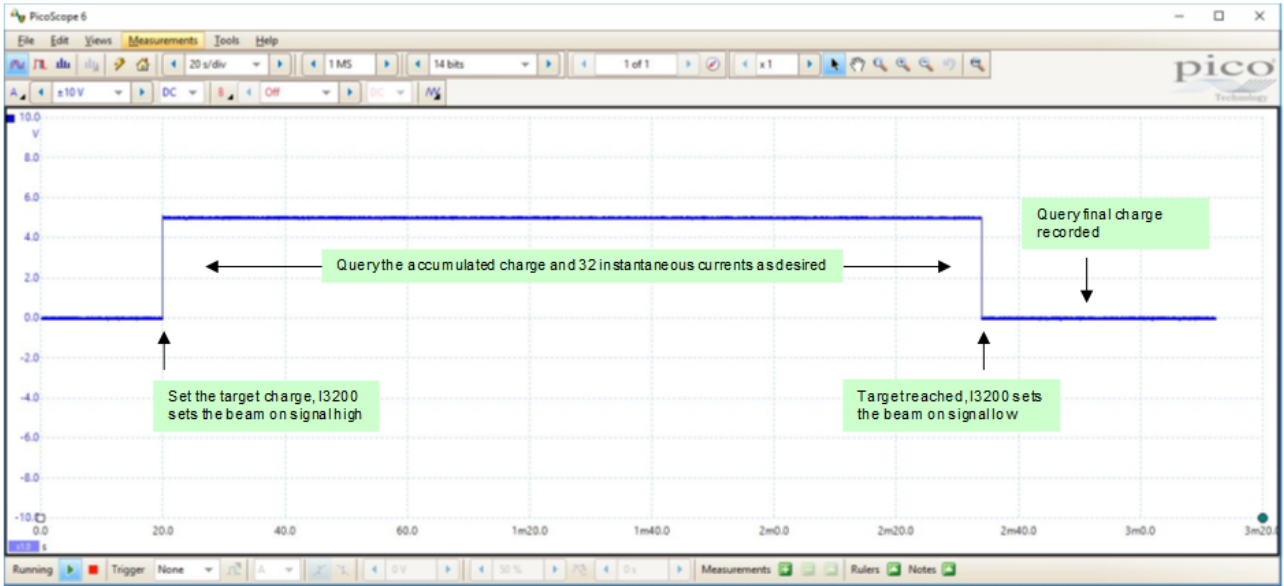

79 : Recording of the beam on signal during dose delivery

19 Connectors

19.1 Front Panel Connectors

19.1.1 Actuator

Dsub 9 pin female. Note: the +5V switched signal is used for beam on/off control by the -DQ dose control firmware option.

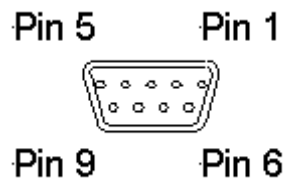

80 : (External view on connector / solder side of mating plug)

1	+24 VDC switched	6	+24 VDC out
2	PSU GND	7	Opto in B
3	+5V switched	8	Screen
4	+24 VDC out	9	Screen
5	Opto in A		

19.1.2 Signal Inputs 1-16

Dsub 25 pin female.

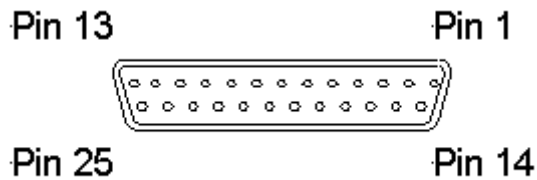

81 : (External view on connector / solder side of mating plug)

1	Input 02	14	Input 01
2	Input 03	15	+5V continuity test
3	Input 04	16	AGND
4	Input 05	17	AGND
5	Input 06	18	AGND
6	Input 07	19	AGND
7	Input 08	20	AGND
8	Input 09	21	AGND
9	Input 10	22	AGND
10	Input 11	23	AGND

11	Input 12	24	Input 16
12	Input 13	25	Input 15
13	Input 14		

19.1.3 Signal Inputs 17-32

Dsub 25 pin female.

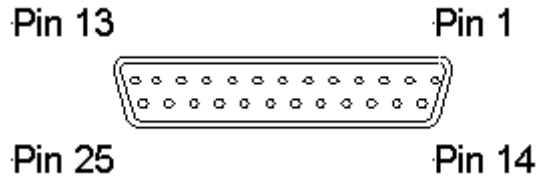

82 : (External view on connector / solder side of mating plug)

1	Input 18	14	Input 17
2	Input 19	15	+5V continuity test
3	Input 20	16	AGND
4	Input 21	17	AGND
5	Input 22	18	AGND
6	Input 23	19	AGND
7	Input 24	20	AGND
8	Input 25	21	AGND
9	Input 26	22	AGND
10	Input 27	23	AGND
11	Input 28	24	Input 32
12	Input 29	25	Input 31
13	Input 30		

19.1.4 Auxiliary HV Out

SHV male. To mate with standard SHV connector such as Radiall R317 005.

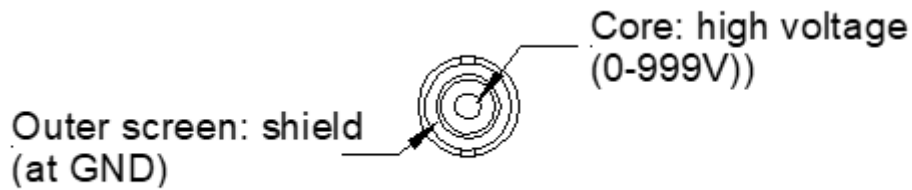

19.2 Rear Panel Connectors

19.2.1 USB Communications

USB type B female.

19.2.2 RS-232 Communications

Six pin mini-DIN socket (PS/2 mouse/keyboard type).

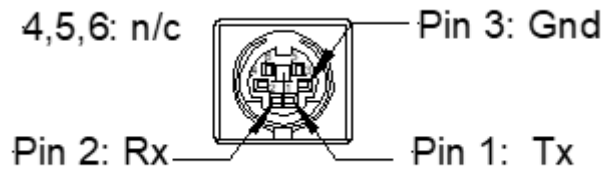

83 : (External view on connector / solder side of mating plug)

19.2.3 Fiber-Optic Communications:

HFBR ST bayonets suitable for 1 mm plastic or 200 um silica fiber.
Light casing = transmitter, dark casing = receiver.

FIBER-OPTIC TX
(Light Gray)

FIBER-OPTIC RX
(Dark Gray)

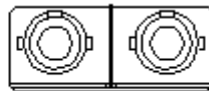

19.2.4 Optical Trigger / Gate Input

HFBR ST bayonet receiver suitable for 1 mm plastic or 200 um silica fiber.

19.2.5 Electrical Trigger / Gate Input

BNC socket (female). To mate with standard signal BNC.

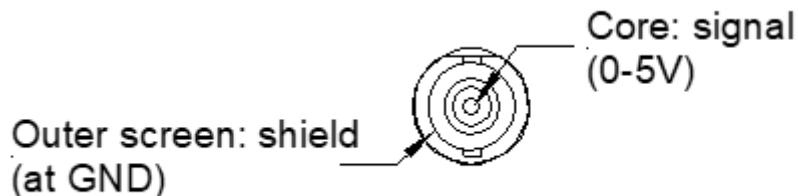

19.2.6 Power Input

2.1 mm threaded jack. To mate with Switchcraft S761K or equivalent

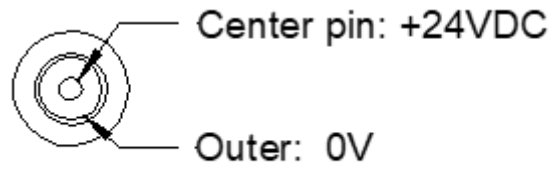

19.2.7 Ground Lug

M4 threaded stud. To mate with M4 ring lug.

20 Controls and Indicators

20.1 Front panel controls

None.

20.2 Rear panel controls

20.2.1 Mode switch

10 position rotary switch setting communications mode. Binary protocols are used for highest data rates by Pyramid Technical Consultants host systems. The fiber optic link can run up to 10Mbps, the USB up to 3 Mbps and the RS-232 up to 115.2kbps. The ASCII protocol is provided for ease of connection to existing systems and simple terminal programs.

Setting	Function
0	9 bit binary, 10 Mbps
1	8 bit binary, 3 Mbps
2	8 bit binary, 115.2 kbps
3	8 bit binary, 57.6 kbps
4	8 bit binary, 19.2 kbps
5	ASCII, 3 Mbps
6	ASCII, 115.2 kbps
7	ASCII, 57.6 kbps
8	ASCII, 19.2 kbps
9	(Reserved)

The switch setting works in conjunction with the connector sensor (see section 21).

20.2.2 Address switch

16 position rotary switch setting device address. Choice of address is arbitrary, but each device in a fiber-optic loop system must have a unique address.

Setting	Function
0	(Reserved to loop controller)
1-15	Available address settings.

20.3 Front panel indicators

20.3.1 Xmit





Green LED. Data being transmitted from the unit. There is a one second delay before the LED extinguishes if communication is interrupted.

20.3.2 Rcv

Green LED. Data being received by the unit. There is a one second delay before the LED extinguishes if communication is interrupted.

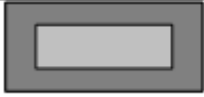

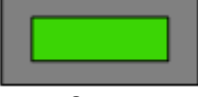
20.3.3 Status



Red/Green LED. This LED indicates a variety of internal states, as follows:

 Alternating red/orange/green/off	Unit powering up
 Off	Unit idle (not measuring)
 Orange	Waiting for trigger; or resetting integrators
 Green	Integrating
 Red	Error
 Alternating green/orange	Downloading program from host

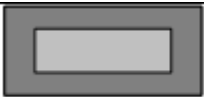
20.3.4 Link

Red/Green LED. This LED indicates a variety of communication states, as follows:

 Alternating red/orange/green/off	Unit powering up
 Off	No connection since last power-up.
 Orange	Unconnected; unit has gone to the safe state.

 <p>Green</p>	<p>Connected</p>
 <p>Red</p>	<p>Fatal communications error</p>
 <p>Alternating green/orange</p>	<p>Boot state (waiting start command or code download)</p>

20.3.5 Power

Green LED. +24VDC power is present.

20.3.6 HV on

Orange LED. Illuminated if the HV supply is enabled.

20.4 Rear panel indicators

20.4.1 USB

Green LED. USB communication is active.

20.4.2 RS-232

Green LED. RS-232 communication is active.

20.4.3 Optical

Green LED. Fiber-optic communication is active.

21 Communications Interfaces

The I3200 is provided with three hardware interfaces, RS-232, USB and fiber-optic. The RS-232 and USB interfaces are intended for simple direct connection to PCs, with no other equipment necessary. The fiber-optic interface provides greater speed, excellent noise immunity, and allows multiple devices to be connected in a looped topology. It requires a fiber-optic adaptor or loop controller device to connect to the host computer. The fiber-optic interface is well-suited to large systems and experiments.

Only one interface is in use at any time. Selection of the active interface is according to the USB and RS-232 cables that are connected.

Cable connected		I n t e r f a c e s e l e c t e d	
USB	R S - 2 3 2	N o n e	
x			U S B
x	x		U S B
	x		R S - 2 3 2
		x	F i b e r - o p t i c

Interface speed and protocol is selected by the mode switch according to the following simplified table, which is also shown on the rear panel of the I3200.

	PSI (10M)	3M	115k	57.6k	19.2k
Binary	0	1	2	3	4
ASCII	5	6	7	8	

The fiber optic interface can run up to 10 Mbps, and the RS-232 up to 115.2 kbps. The USB port always runs at 3 Mbps, irrespective of the mode switch position. The following table summarizes the interface selection and protocol that is active for all possible connector and mode switch configurations. .

Cable connected			Interface selected	Protocol selected by mode switch setting									
USB	RS-232	None		0	1	2	3	4	5	6	7	8	9
x			USB	BIN 8 3M	BIN 8 3M	BIN 8 3M	BIN 8 3M	BIN 8 3M	AS C 8 3M	AS C 8 3M	AS C 8 3M	AS C 8 3M	??
x	x		USB	BIN 8 3M	BIN 8 3M	BIN 8 3M	BIN 8 3M	BIN 8 3M	AS C 8 3M	AS C 8 3M	AS C 8 3M	AS C 8 3M	??
	x		RS-232	??	??	BIN 8 115 k	BIN 8 57.6k	BIN 8 19.2 k	AS C 8 115 k	AS C 8 115 k	AS C 8 57.6k	AS C 8 19.2 k	??
		x	Fiber-optic	BIN 9 10M	BIN 8 3M	BIN 8 115 k	BIN 8 57.6k	BIN 8 19.2 k	AS C 8 115 k	AS C 8 115 k	AS C 8 57.6k	AS C 8 19.2 k	??

- BIN 8: 8-bit nibble-oriented binary
- BIN 9: 9-bit full binary
- ASC 8: 8-bit ASCII, SCPI message format
- ?? Undefined

22 Communications Protocols

22.1 Overview

The I3200 supports three types of communication protocol, selected according to the setting of the mode switch:

1. An eight bit ASCII protocol, messages compliant with SCPI. The low seven bits are used to encode the ASCII character. The eighth bit is only set for synchronization when the <ACK>, <BELL>, <CR>, <LF>, and <ESC> characters are transmitted.
2. An eight bit binary protocol. The first and last bytes of the entire command or reply have the eighth bit set and contain the address. All other bytes in the messages are broken into two bytes, encoded into the low nibble (4 bits), thus never having the top bit set.
3. A nine bit binary protocol. Synchronization is done with the ninth bit. The first and last byte of each message have the ninth bit set and contain the address, and all other bytes are unmodified binary (with the ninth bit clear).

ASCII messaging is provided for users who wish to use existing host software systems that provide convenient support for ASCII communications. All the capabilities of the I3200 are available through a familiar virtual instrument model and message structure. A terminal program such as Windows Hyperterminal, RealTerm or puTTY is sufficient to establish communication with the device. It is possible to communicate with multiple devices at different addresses on the same channel by selecting a particular address to be the listener device at any time.

The binary messaging is more efficient in its use of communications bandwidth. It is fully deterministic with embedded addressing in the messages and immediate responses, including error reports, from the devices. Pyramid provides software drivers and diagnostic host programs for users who wish to use binary communication protocols. Eight bit binary is primarily intended for direct host to device communication, for example via RS-232 or USB links. Nine bit binary is reserved for the 10 Mbit/s fiber-optic channel, and is highly recommended for larger systems with multiple addressable devices in a loop.

22.2 ASCII Protocol - SCPI

Standard Commands for Programmable Instruments (SCPI) is an extension of the IEEE 488.2 standard. This was originally developed by Hewlett-Packard for the HP-IB (later GP-IB) interface before being adopted by the IEEE, and is widely used by manufacturers of measurement equipment. The I3200 implements the 1999.0 revision of SCPI (© 1999 SCPI Consortium).

22.2.1 Messages

The first bit of every eight bit group in a message is the start bit, followed by seven bits encoding a character from the ASCII character set.

A full command from the host to the I3200 comprises as many ASCII characters as needed to form the message, terminated by the LF (0x0A, Ctlr-J) character. The I3200 will not start to process a command until the 0x0A character is received. The list of valid commands is listed in the next subsection. If the communications is being handled in a terminal session, the terminal program should send CR (0x0d) before the LF to get a legible display. The CR is ignored by the command interpreter in the I3200.

The I3200 generates a reply to every message from the host when it is the listener. The first byte of its reply will always be a single non-printing character. The first character is ACK (0x06) when the command has been successfully executed with no errors. Responses to host commands with a '?' will then have the required data, terminated with the CR,LF sequence. If the host is not requesting data (no "?"), no other bytes will be transmitted after the ACK. If the I3200 generates an error when executing the host command, it will transmit a single BELL (0x07) as its response. A computer

running a terminal program will therefore “beep” when the I3200 cannot execute a command, for example due to incorrect syntax. A more interactive “terminal mode” can be selected which modifies this behavior to make the I3200 more user-friendly when it is being driven from a terminal program.

Device addressing is performed using the special command ‘#’. Addressing is only necessary for devices linked by a fiber-optic loop, but a device is made the “listener” when the host sends #ADDRESS. For example, #4 will make the device with address 4 the listener. You must ensure that all devices on the same communications channel have unique addresses. All subsequent commands sent (without address) will be listened and responded to by device 4 only. The host message #? asks who the listener is. The # command can be sent as a compound message, such as #3;*IDN?.

22.2.2 Status registers

The I3200 implements the IEEE 488.2 status register method. Each of the registers is masked by a corresponding enable register. It is recommended that you set all the enable registers to all 1's. The host software should use the *STB? command to watch for changes to the status of the I3200, and then *ESR?, :STATus:OPERation:CONDition? or :STATus:QUESTionable:CONDition? as appropriate to recover the details from the relevant register.

Status Structure

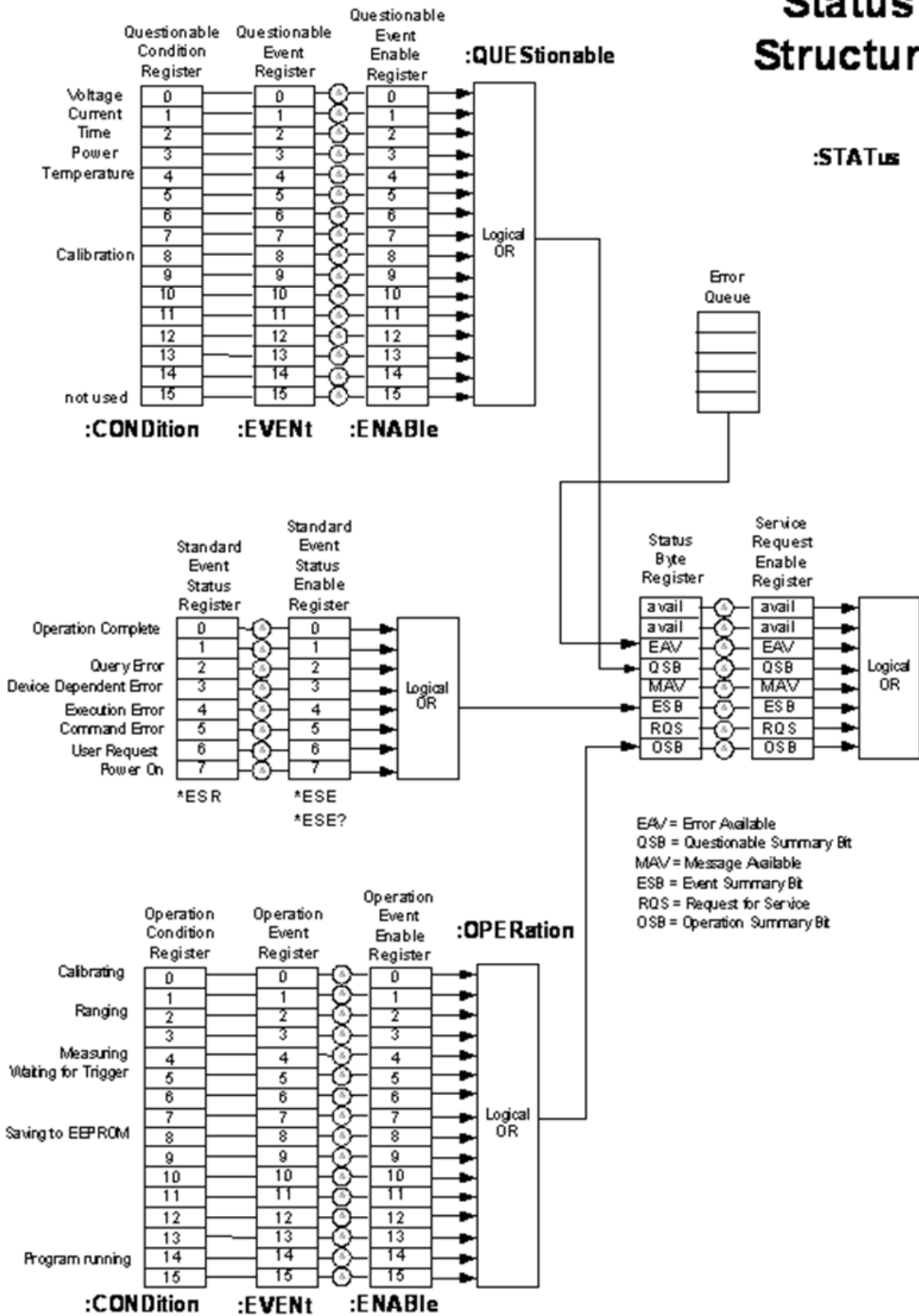

84 : SCPI Status register structure

22.2.3 Host Commands

The I3200 responds to the mandatory commands prescribed by SCPI and IEEE 488.2, plus specific commands as required by the operation of the device. The commands are grouped with a hierarchical structure, with the levels separated by the colon character. For example:

CONFigure:GATe:INTernal:PERiod 1e-2 5

This command configures the internal integration gate to have a length of 10 milliseconds with five sub-samples of the integrator output, after 2, 4, 6, 8, and 10 milliseconds.

SCPI provides for a long and short form for each command. The short forms are indicated by the capitalized part of the command. { } denotes a required argument, [] denotes an optional argument.

Some commonly-used commands are available from the root of the hierarchy, as a shortcut, as well as in their logical position in the structure. For example:

CAPacitor 1
and
CONFigure:CAPacitor 1

are equivalent ways to switch in the large feedback capacitors on the four channels.

A number of commands are password protected to reduce the chance of changing them accidentally. The commands only effective after the device has been rebooted if they have been enabled by first sending

SYSTem::PASSword 12345

Sending any other number as the argument of this command disables the protected commands again.

ADDRESSING DEVICES

SCPI does not provide specific commands for addressing multiple devices, because this was handled by hardware in the original IEEE 488.1 specification. The I3200 provides a simple mechanism for making any device on the loop the listener. The device will remain the listener until another device is selected.

```
# {address} // Make device address (1 to 15) the listener
#? // Query which device is listener.
```

IEEE 488.2 MANDATORY COMMANDS

Commands which have a query equivalent for readback are marked with “(?)” in the following tables. Parameters are generally passed to the I404 with the set version of the command, but no parameters are passed for the query version. For example,

```
*ESE 3 // set the Event Status Enable register to 0000011
*ESE? // query the Event Status Enable register
```

*CLS		Clear Status Command. Clear all event registers and the error queue
*ESE	(?)	Program (query) the state of the Event Status Enable register. 8 bits. I3200 returns decimal value.
*ESR?		Standard Event Status Register Query. Query the state of the Event Status register. I3200 returns decimal value.
*IDN?		Identification Query. I3200 returns manufacturer, model number, serial number, firmware version

*OP C	(?)	Set (query) the Operation Complete bit in the Standard Event Status Register after all pending commands have been executed. Not currently supported.
*RS T		Reset Command. Return the device to the *RST default conditions.
*SR E	(?)	Program (query) the Service Request Enable register. Not currently supported.
*ST B?		Read Status Byte Query. Query the Status Byte Register. I3200 returns decimal value.
*TS T?		Self-Test Query. Perform a checksum test on ROM and return the result. I3200 returns <1>.
*WA I		Wait-to-Continue Command. Wait until all previous commands are executed. Not currently supported.

IEEE 488.2 optional commands

*RCL		Recall instrument state from EEPROM.
*SAV		Save present instrument state to EEPROM.

The settings covered by *RCL and *SAV are:

- SOURce
- CONFig:ACCumulation
- CAPacitor
- PERiod
- CONFig:GATE:EXTernal:POLarity
- TRIGGER:SOURce
- TRIGger:POInts

Note that the high voltage settings (CONFigure:HIVoltage) are NOT included.

IEEE 488.2 required commands

Command structure			Q?	Description
SYSTem	:ERRor	[:NEXT]?		Query the error/event queue for the next item and remove it from the queue. *ERR? is an alias for this command.
	:VERSion?			Query the SCPI standard version.

STATus	:DAC {Ch} {Val}				Not currently supported.
--------	-----------------	--	--	--	--------------------------

I3200 COMMANDS

Command structure				Q?	Description
ABORt					Abort measurement
ACTUATErelay {0 1}				(?)	Set (query) the 24 V output to drive the actuator out / in. Limit switch states are available in the digital byte.
CALIBration					Calibrate device
	:GAI{n} [{CLEar}]				Calibrate gain for each channel or reset stored gains to nominal.
	:GAI{n}? {0 1}				Query gains for each channel for capacitor 0 = small value, 1 = large value
	:SOURce {0 1 2 32}			(?)	Turn on (query) internal calibration source, 0 = off, 1 = on ch1, 2 = on ch2 etc
	:RCL				Recall the gains from EEPROM
	:SAV				Store the gains to EEPROM

CAPacitor {0 1}				(?)	Set (query) feedback capacitor for all channels; 0 = small value, 1 = large value
CONFigure					Configure device
	:ACCumulation {0 1 2 3}			(?)	Accumulate (query) charge across gate resets, 0 = do not accumulate, 1 = accumulate by interpolation, 2 = accumulate by no-lost charge method, 3 = accumulate without correction for deadtime during resets
	:CAPacitor {0 1}			(?)	Set (query value in F) feedback capacitor (all inputs), 0 = small value, 1 = large value
	:GATe				Configure integration gate
		:EXTernal			Configure external integration gating
			:POLarity {0 1}	(?)	Set (query) external gate polarity (external trigger only), 0 = high active, 1 = low active

		:INTernal			Configure internal integration gating ...
			:LOSSless {0 1}	(?)	Set (query) lossless integration mode, 0 = off, 1 = on
			:PERiod {<total> AUTOscale} [<subsamp>]	(?)	Set (query) integration period in seconds or enable autoscaling, <subsamp> subsamples per period (default 1)
			:RANGE {<amps>} [<subsamp>]	(?)	Set a full scale current range by adjusting integration period for the selected capacitor, <subsamp> subsamples per period (default 1)
			:RESET {<reset>} {<settle>} {<setup>}	(?)	Set (query) the reset, settle and setup times (password protected)
	:HIVoltage				High voltage configuration ...
		:ENable?			Query the high voltage enable state, 0 = all HV off, 1 = external bias HV on
		:EXTernal			External (auxiliary) high voltage configuration ...

			:MAXvalue {<volts>}	(?)	Set (query) maximum allowable external high voltage setting (password protected)
			:VOLTs {<volts>}	(?)	Set (query) the external high voltage
CONFigure?					Query the last CONFIGURE or MEASURE command.
FETCh					Fetch data
	:CHARge?				Fetch last charge data <integration period, charge1, charge2, charge3, charge32, over range byte>
	:CURRent?				Fetch last current data <integration period, current 1, current 2, current 3, current 32, over range byte>
	:DIGital?				Fetch digitals (bit0-2 = reserved, bit3 = HV enabled, bit4 = external gate present, bit5 = actuator limit A set, bit6 = actuator limit B set))

FETCh?					Do same FETCh as last (defaults to fetch charge if no defined last FETCh)
INITiate					Initiate taking readings as soon as triggered (immediately if internal trigger mode)
PERiod {<period> [<sub>]}]				(?)	Set (query) integration period in seconds, minimum 1e-4 s, maximum 6.5e+1 s, <sub> subsamples per period (default 1). Shortcut version of command.
READ					Initiate, fetch data from single acquisition when complete
	:CHARge?				Read charge data <integration period, charge1, charge2, charge3, charge32. over range byte>
	:CURRent?				Read current data <integration period, current1, current2, current3, current 32. over range byte>

	:DIGital?				Read digitals (bit0-2 = reserved, bit3 = HV enabled, bit4 = external gate present, bit5 = actuator limit A set, bit6 = actuator limit B set)
READ?					Do same READ as last (defaults to charge if no defined last READ)
DOSETARget {<value>}				(?)	Load (query) the target accumulated charge value in coulomb and set the 5V test output line high. -DQ dose control option firmware only.
DOSEVALue?					Query the accumulated charge value. -DQ dose control option firmware only.

BACK {0 1}				(?)	1: Obtain (query) and store background value for charge accumulation by taking average of 100 samples and use for subsequent dose control. 0: Clear the stored background value. -DQ dose control option firmware only.
STATus					Status registers
	:OPERation				Operation register
		:CONDition?			Query condition
		:ENABle			Set (query) enable
		:EVENT?			Query event
	:QUEStionable				Questionable register
		:CONDition?			Query condition
		:ENABle			Set (query) enable
		:EVENT?			Query event
	:PRESet				(Not used)
SYSTem					System commands
	:COMMunicatio n				Communication settings

		:CHECKsum {0 1}		(?)	Append (query) checksum to all replies (password protected); 0 = off, 1 = on
		:ECHO {0 1}		(?)	Enable (query) message echo, 0 = echo off, 1 = echo on
		:TERMinal {0 1}		(?)	Enter (query) terminal mode (password protected), 0 = off, 1 = on. In terminal mode, ACK and NACK are not sent, and "OK" or error response is sent for all valid commands that do not otherwise generate a response.
		:TIMEout {<timeout>}		(?)	Set (query) timeout in seconds (password protected); 0 = timeout disabled. I3200 will go to unconnected state if no valid message is received in the timeout period.
	:ERRor?				Return next error in the error event queue.

	:FREQuency {<frequency>}			(?)	Set (query) dominant noise frequency (generally line frequency, 50 or 60 Hz). The parameter is used during calibration.
	:PASSword			(?)	Enter (query) the device password to allow access to protected functions. Default 12345.
	:SAFEstate			(?)	Enable (query) going to the safe state when unconnecte d (0 = do not go to safe state when unconnecte d, 1 = go to safe state when unconnecte d)
	:SERIALnumber {<string>}			(?)	Set (query) the device serial number to <string> (max ten alphanumeric) (password protected)
	:VERSION?				Return the SCPI standard version.
TRIGger					Establish trigger conditions

	:COUNT?				Query the trigger count since the last INITiate
	:POINTs {<number> INFinite}			(?)	Set (query) the number of trigger points after an INITiate before acquisition stops. INFinite means no limit.
	:SOURce {INTernal GATed TRIGgered}			(?)	Set (query) the acquisition trigger source (Note ExternalStart Stop and ExternalStart Hold not supported in ASCII messaging).

22.3 ASCII Protocol – Terminal Mode

SCPI is not ideal for a user trying to control the I3200 from a terminal program. A more interactive terminal mode can be turned on by sending the command

SYSTEM:COMMunication:TERMinal 1

After this command is executed, the I3200 will provide a response to every command. Valid query commands will get their normal reply. Other commands will generate an <OK> response if they were interpreted without errors, or an error message if they could not be interpreted. The non-printing ACK and BEL characters are not sent.

22.4 Binary protocol

The binary protocol is optimized for deterministic loop operation and is primarily intended for use with Pyramid Technical Consultants host software and software device drivers. Users who wish to develop their own host software using binary communications are advised to use the supplied device drivers. For further details contact Pyramid Technical Consultants, Inc.. The device model for the binary communications is essentially the same as for ASCII, and particularly the terminal mode. All host messages get an immediate response from the I3200. There are a range of summary level commands that are unavailable under SCPI.

23 Techniques for Making Low Current Measurements

Measurements of currents of around 10 nA and below require some care to prevent unwanted interference that can distort the results. In particular, the conductor that carries the current to the I3200 input (the sensitive node) must be carefully isolated and guarded to ensure unwanted currents cannot flow into it.

When an unexpectedly high background offset current is seen, the first thing to do is to check again with the signal input(s) disconnected from the I3200. This will isolate the problem to the external measurement circuit, or within the I3200 itself. If it is possible to swap the inputs between the I3200 channels, this can also help to localize problems.

23.1 Guarding and screening

If the sensitive node is separated from a voltage source (such as a power rail) by an insulating layer, then a small current will flow through the finite impedance of the insulator.

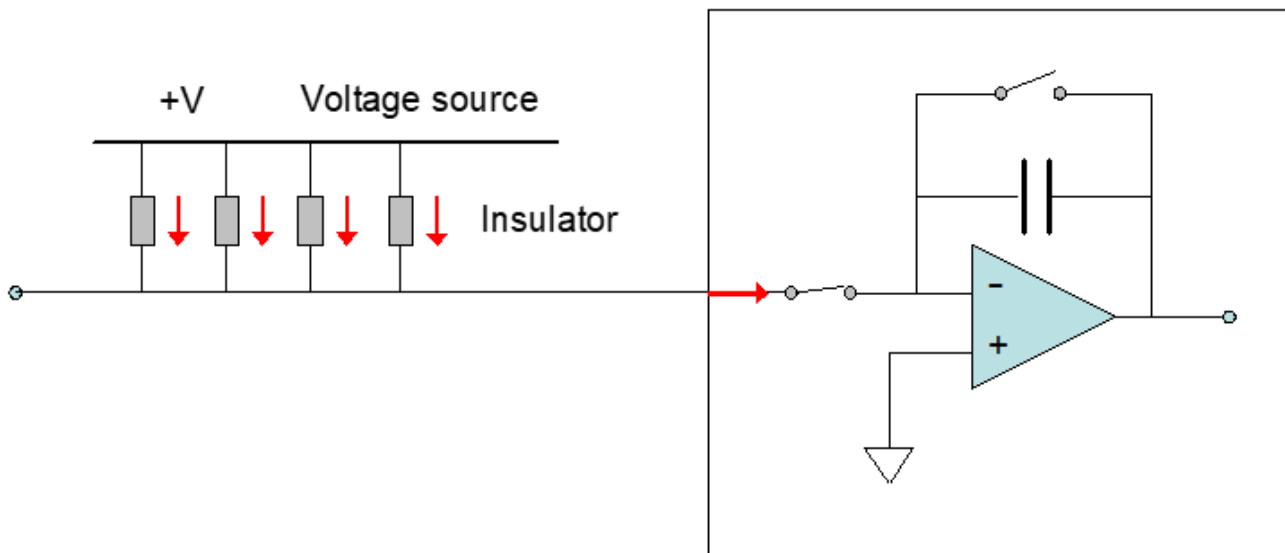

85 : Offset current to unguarded input

For example, a 10 V conductor separated from the sensitive node by 1 Gohm of total resistance would drive in 10 pA of background current. If the insulation is compromised by contamination, then the problem is magnified. The solution is to provide a guard shield around the sensitive node, at the same electrical potential. Leakage currents across insulators now flow to the guard, where they do not affect the reading.

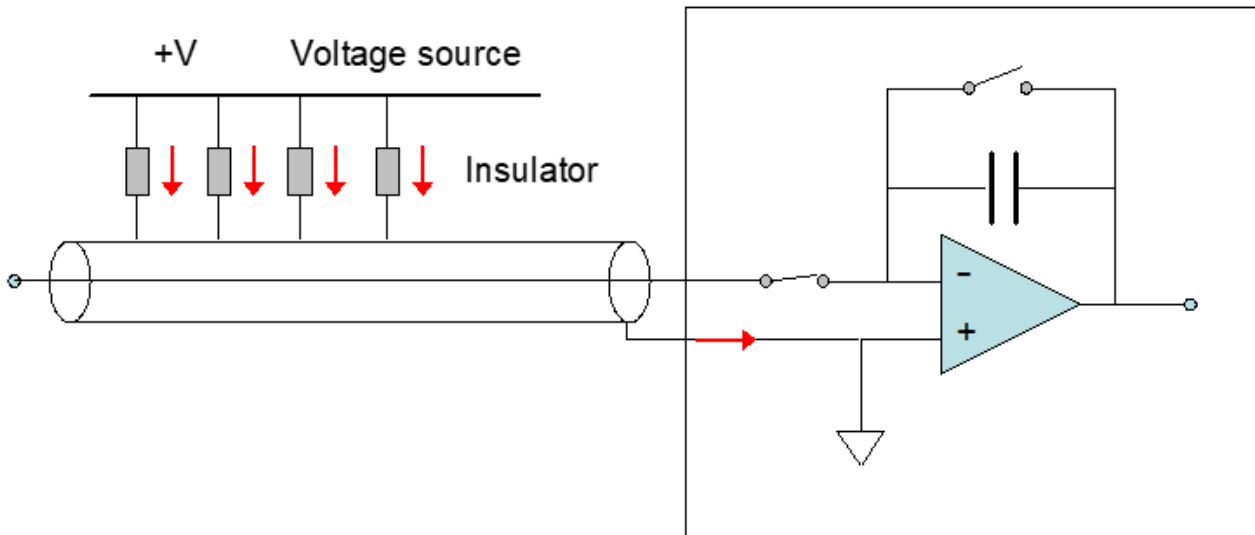

86 : Guarded input

AC fields in the environment can induce AC currents in the sensitive node. Depending upon the frequencies and the integration time in use, these may appear as noise fluctuation in the signal. An outer cable screen is used to shield the sensitive node from external fields. In combination with the need to guard the sensitive node, the result is that the use of cable that provides a guard and a screen is necessary. The core and inner guard screen are at I3200 analog ground potential, and the outer screen is made directly to the chassis of the I3200.

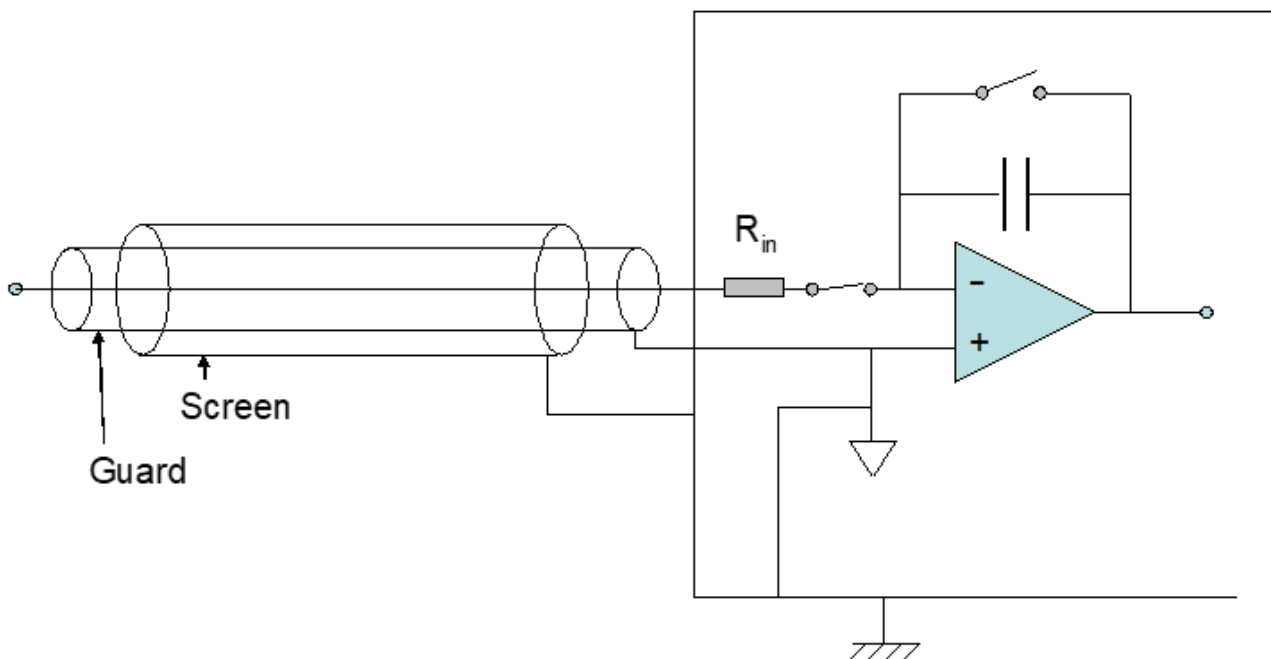

87 : Guarded and screened input

Since the noise sources can often be modeled as voltage sources, you can often reduce the noise they induce at the integrator inputs by adding series resistance. The I3200 has this option, and the size of the series resistor R_{in} can be specified at the time of ordering. Note that very high values increase the time constant of the low pass filter formed from this resistor and the cable and detector capacitance, and therefore may degrade the response time of the system.

23.2 Temperature

Offset currents are generally exacerbated by increased temperatures. Temperature fluctuation can appear as variation in the reading. When very small currents need to be measured, the experimental arrangement should be temperature stabilized as far as possible.

23.3 Triboelectric effects

When there is relative movement of insulators and conductors in signal cabling, free charge is released. This is particularly the case for the screen of coaxial cable. The resulting potential difference can drive small currents to the signal conductor across the high impedance of the insulator. Additionally, charge may leak in directly if there are any breaks in the insulator.

Special low-noise cable is available with graphite lubrication bonded to the insulator, to reduce charge generation, and to conduct any released charge away harmlessly. Other mitigations include keeping the signal cables short and motionless.

23.4 Battery Effects

Ionic contamination, such as salt from fingerprints, which connects to the sensitive node, can give battery effects, particularly in the presence of moisture, which can drive unwanted currents. Any insulating surfaces in contact with the sensitive node must be clean. Humidity levels should be such that there is no moisture condensation. Wherever possible the sensitive node should be insulated by vacuum or air.

23.5 Piezoelectric Effects

Ceramic and plastic insulators can release charge when under mechanical stress, which may be collected on the sensitive node. The effect is generally small (less than 10 pA), and can be avoided by eliminating stresses in cables and connections.

23.6 Integration Period and Synchronization

The I3200 provides considerable flexibility in setting the integration time interval and synchronizing the integration to external events. The integration method is inherently good at averaging noise. Very low current currents generally require the smallest available feedback capacitor and the longest practicable integration time to build up a readily measurable voltage. For example, a 1 pA current integration on a 10 pF feedback capacitor requires 10 seconds to develop 1 V. Background offset is also integrated, of course, and cannot be distinguished from the signal. This sets the ultimate detection limit.

The plots in figure 86 illustrate how a 5 pA signal from a small ionization chamber becomes clearly distinguishable from a reference background signal, and the noise reduces, as the integration period is increased from 1 msec to 100 msec to 10,000 msec.

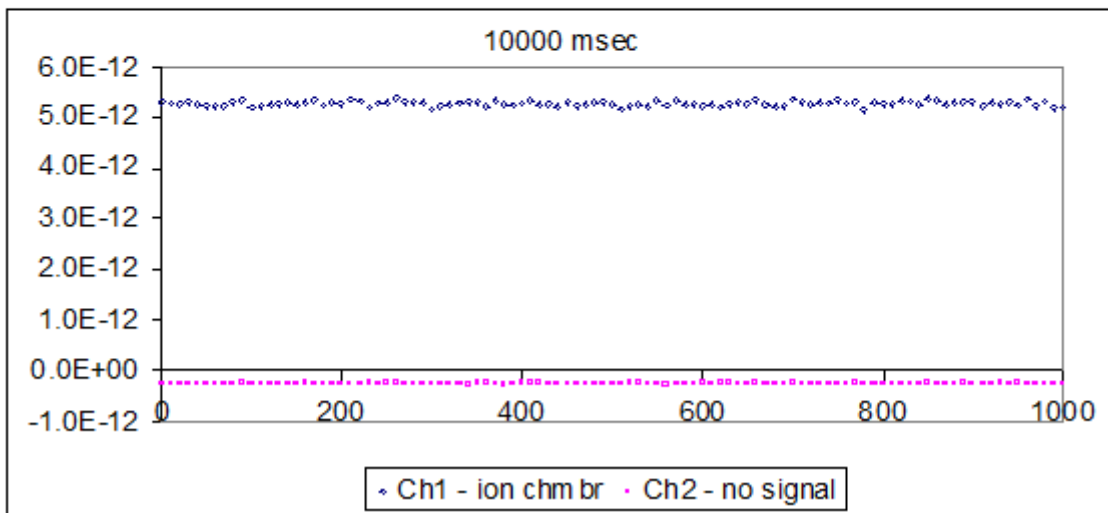
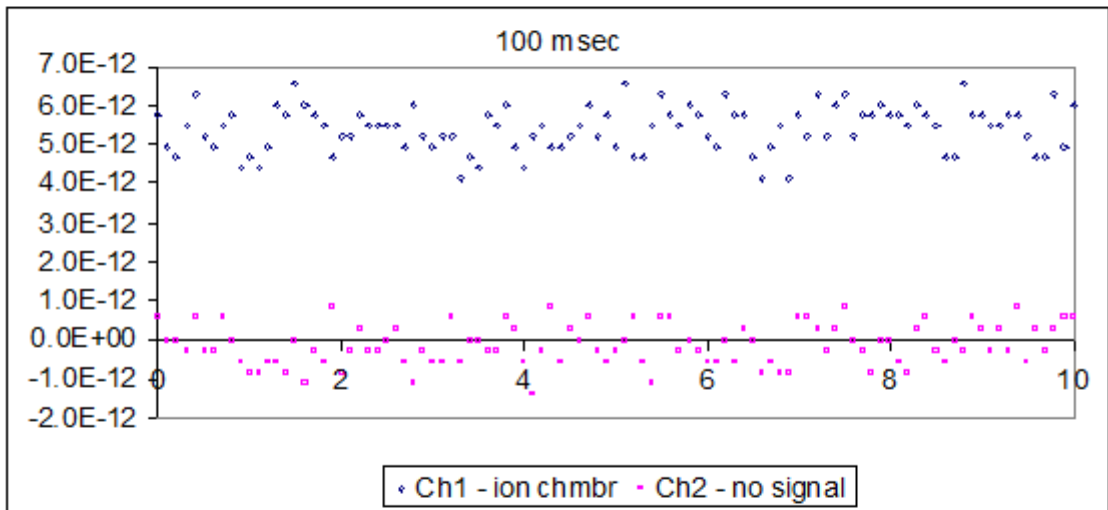
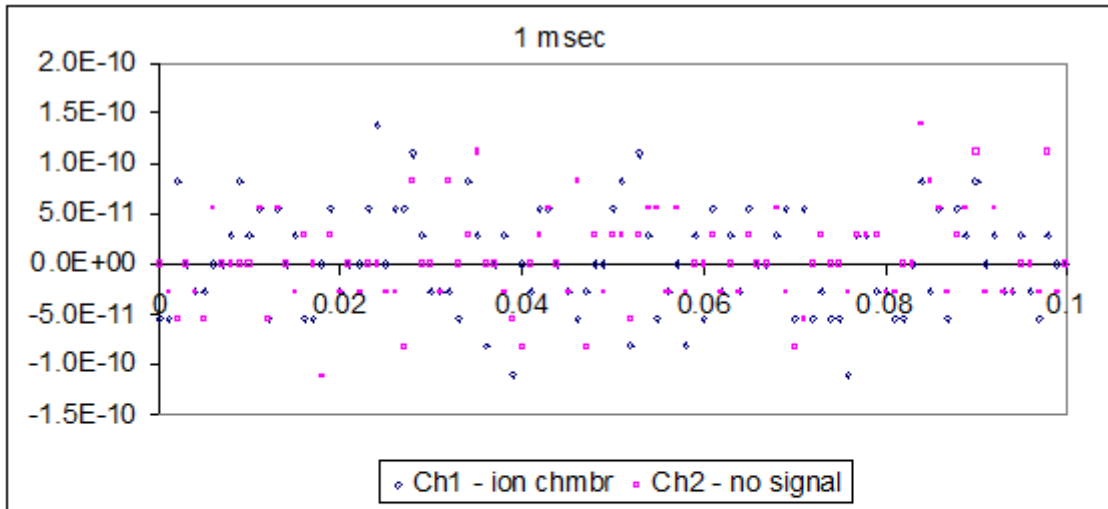

88 : Separation of a 5 pA signal from background

Where there are known dominant noise frequencies in current measurements, for example line voltage interference, these can be suppressed by choosing an integration periods that is an integer multiple of the noise period. For example, 50 Hz or 60 Hz noise from the power line is present in

most environments. This can be completely removed in the I3200 by selecting the integration period as follows:

Noise frequency	Integration period choices to eliminate noise
50 Hz	20.00, 40.00, 60.00, 80.00, 100.00 K x 20.00 msec
60 Hz	16.67, 33.33, 50.00, 66.67, 83.33, K x 16.67 msec

Very small charge package measurements should be optimized by synchronizing the integration carefully around the arrival of the charge. This minimizes the amount of background offset current that is included in the reading. Often the arrival of the charge is associated with an event in the system which can be used to drive the external gate input of the I3200 to obtain the required synchronization.

23.7 Summary

Factor	Typical noise offset current	Mitigation	Typical noise after mitigation
Triboelectric effects in cable	10^{-8} A	Reduce cable lengths. Keep cable from moving. Use low-noise cable.	10^{-12} A
Current across insulators from voltage sources	10^{-7} to 10^{-10} A	Guard the sensitive node Use triaxial cable	10^{-12} A
AC interference	10^{-6} to 10^{-10} A (AC)	Used screened (triaxial) cable	10^{-12} A
AC interference	10^{-6} to 10^{-10} A (AC)	Select increased series input resistance at time of ordering	10^{-12} A
AC interference	10^{-6} to 10^{-10} A (AC)	Use integration periods that are an integer multiple of the dominant noise frequency.	10^{-12} A
Contaminated insulators	10^{-8} A	Clean insulating surfaces with solvent Use air insulation where possible Keep humidity low	10^{-13} A
Piezoelectric effects	10^{-12} to 10^{-13} A	Avoid mechanical stresses and vibration, in the sensor and cable.	Negligible
Resistor Johnson noise	$< 10^{-14}$ A	None – fundamental limit set by signal source resistance	
Temperature fluctuation	10^{-9} to 10^{-12} A fluctuation	Temperature stabilize the whole measurement apparatus	10^{-10} to 10^{-14} A fluctuation
Elevated temperature	10^{-13} to 10^{-11} A	Reduce temperature of the whole measurement apparatus	10^{-13} A

24 Software Updates

The I3200 has three embedded firmware releases.

Firmware	Function
FPGA (.pof file / .fhex file)	General logic, loop message passthrough, ADC reading and averaging
PIC Boot (.hex file)	Boot up, code upload
PIC Application (.hex file)	Main application; calibration, conversion to floating point values, communication messaging.

The PIC microcontroller boot code should not require updating. It would require access to the circuit board and dedicated programming tools to load new code. If the boot code ever does need to be updated, your supplier will contact you and make arrangements either to return the unit for upgrade, or to have an engineer perform the upgrade for you.

The FPGA and PIC microcontroller application code may be updated periodically to add new operating features. New code releases will be provided by your supplier, or can be downloaded from the Pyramid Technical Consultants, Inc. website. The fhex (for FPGA) and hex (for PIC microcontroller) files can be loaded using the PTC Diagnostic host software without any need to access the unit. The uploads can be performed directly from the PC host.

24.1 FPGA firmware updates

To update the FPGA, click the “Select .fhex file” button under Upload FPGA on the Device tab, and navigate to the relevant file. The code will then load. The process takes about one minute.

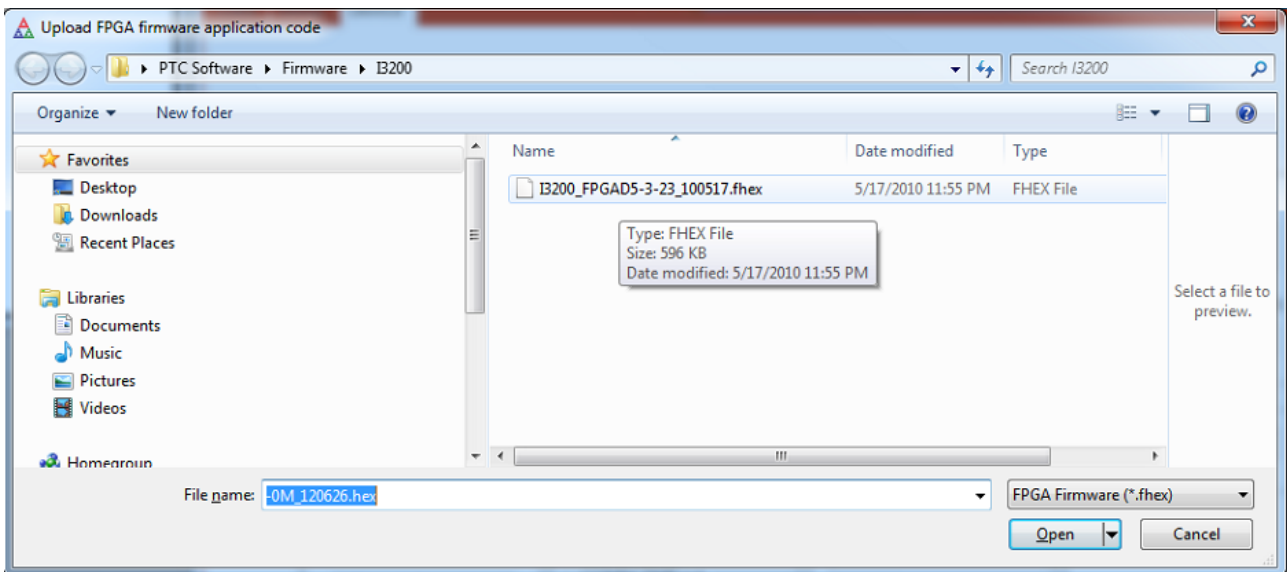

89 : Selecting the FPGA fhex file to load.

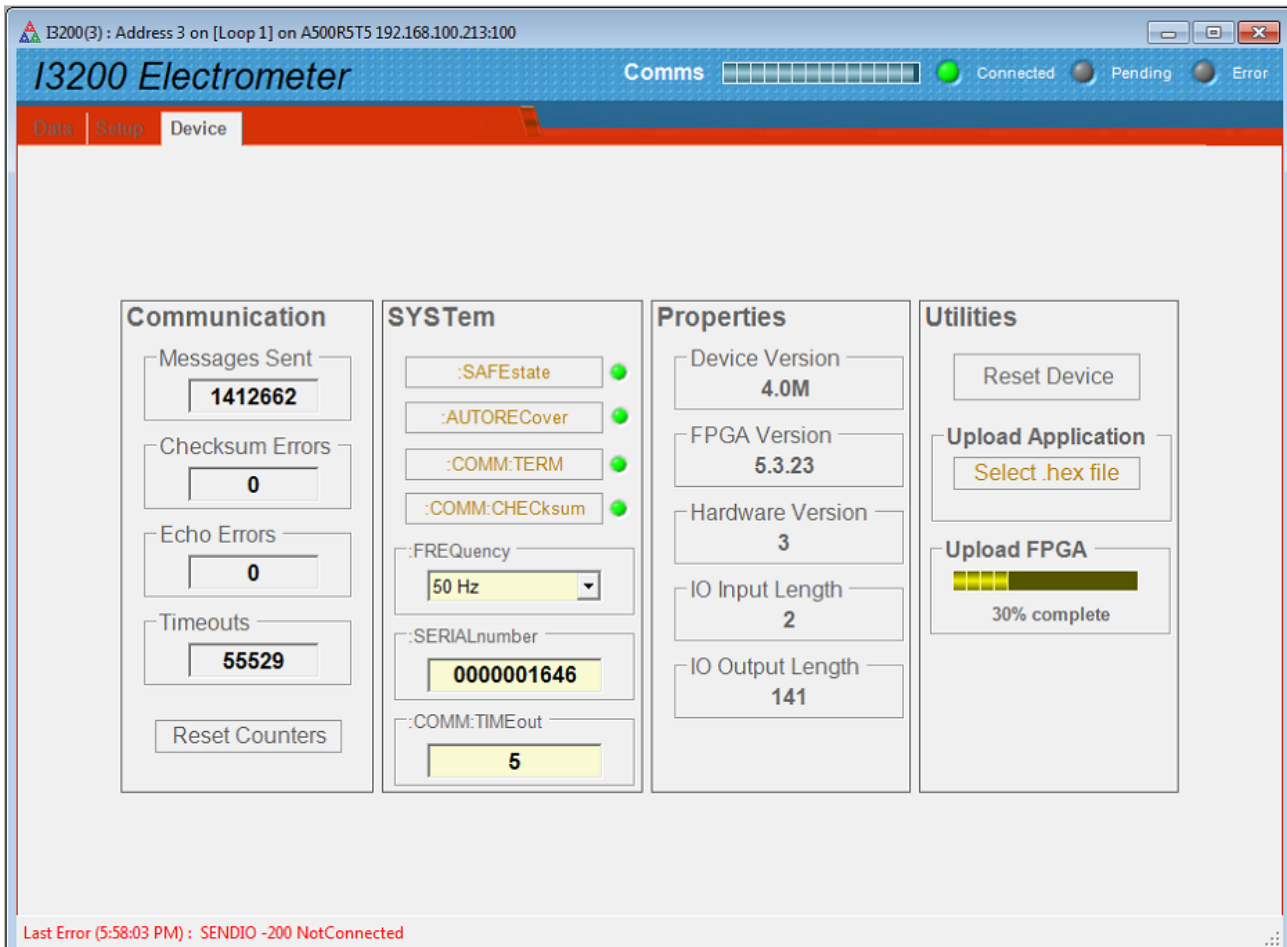

90 : FPGA firmware uploading (PTC DiagnosticG1).

When the upload is complete, you will get a prompt to power cycle the I3200 in order to load the new code.

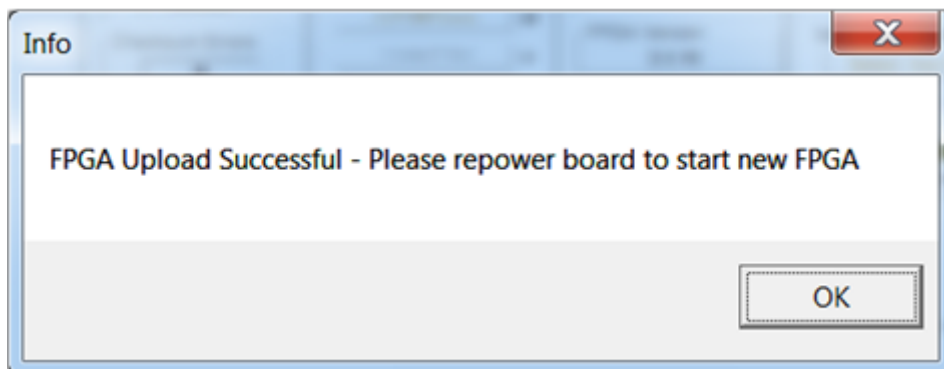

91 : Restart prompt after FPGA update.

If the FPGA upload fails for any reason such as loss of power during the upload, or data corruption, then the I3200 may not be able to communicate. In the unlikely circumstance that this happens, it can be recovered using an FPGA programming tool and the .pof version of the FPGA code. Contact your supplier or Pyramid Technical Consultants who will arrange for the unit to be repaired.

24.2 PIC firmware updates

To update the PIC microcontroller, click the "Select .hex file" button on the Device tab and navigate to the relevant file. The code will then load. The process takes about 30 seconds.

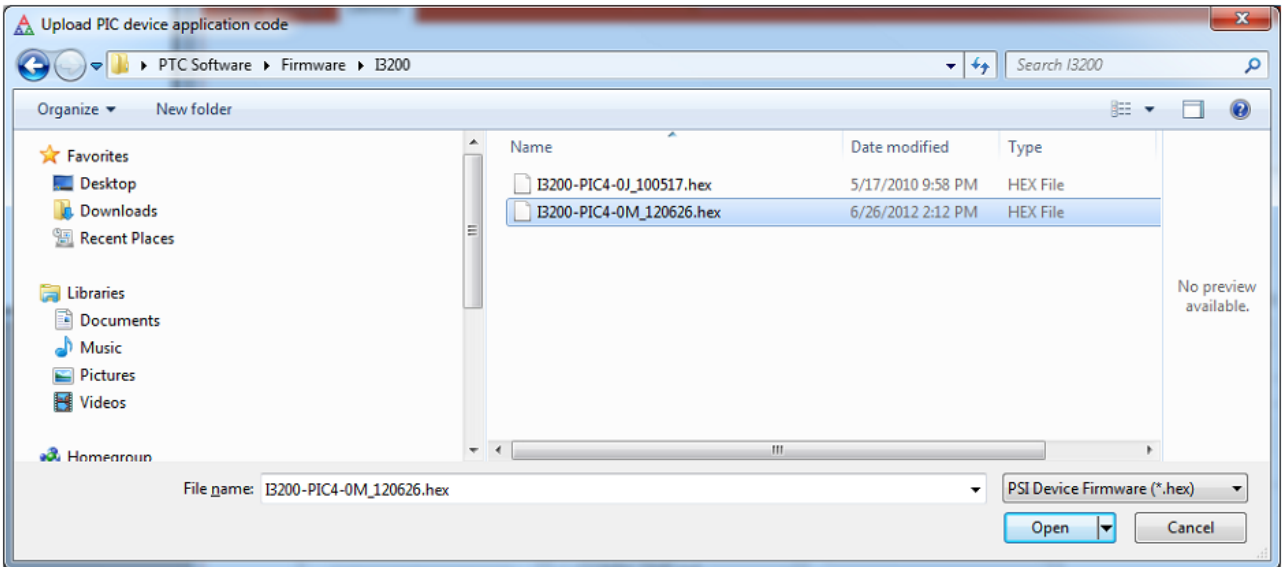

92 : Selecting the PIC hex file to load.

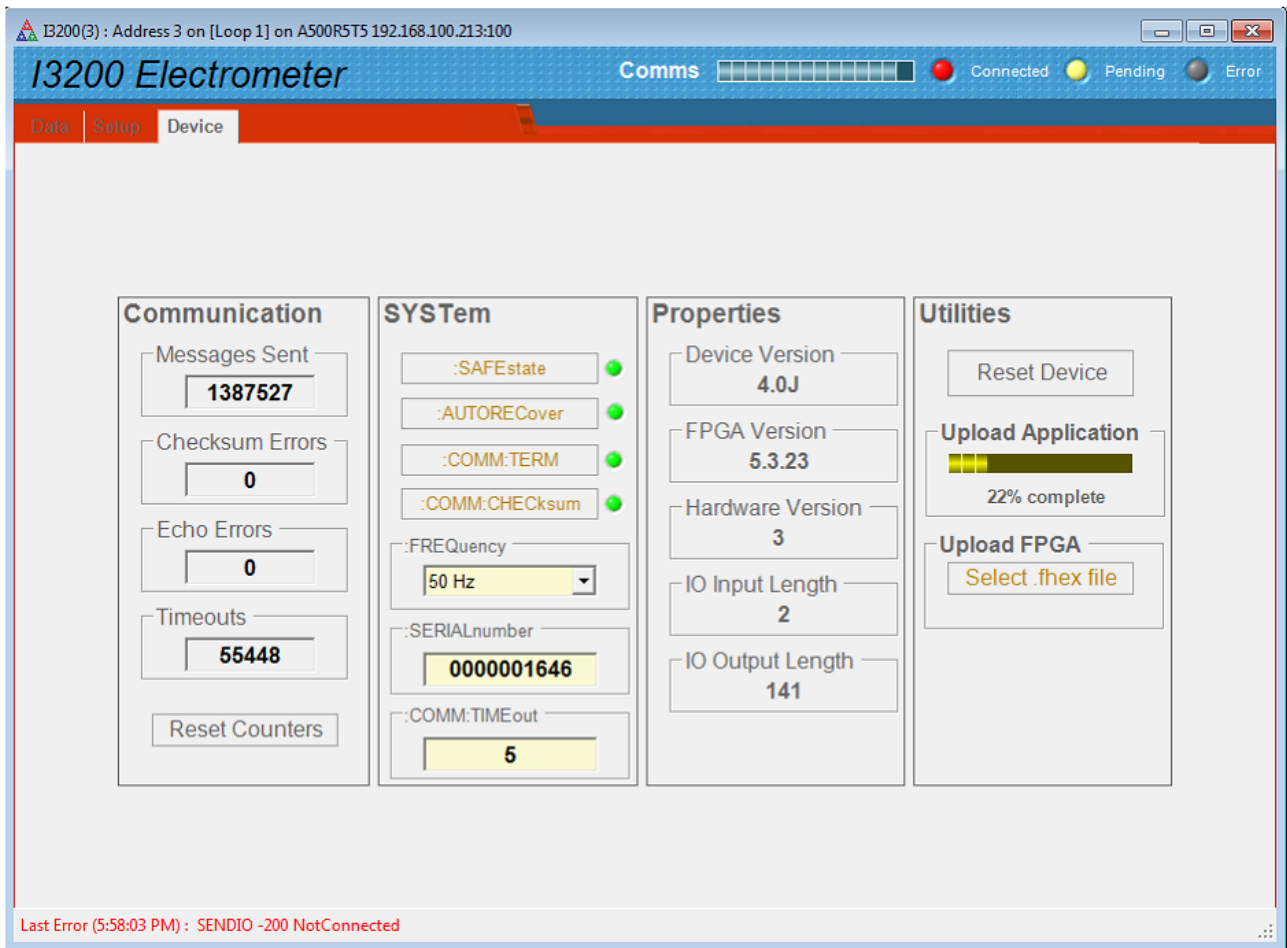

93 : PIC firmware uploading

When the upload is complete, the I3200 will reset itself and start running the new firmware. You should see the new device version number displayed on the screen.

25 Troubleshooting

Symptom	Possible Cause	Confirmation	Solution
High background current	Resistive path to signal input due to missing or broken guard.	Disconnect input – background should reduce to specification levels	Ensure good guard integrity all the way to the signal source.
	High humidity	Problem varies with relative humidity.	Ensure there are no water-absorbent insulators. Reduce the humidity levels.
	Internal contamination.	Background current remains high with inputs disconnected.	Contact your I3200 supplier for advice or to organize a return for cleaning.
High noise levels	Integration time too short for signal being measured	Noise level reduces with integration period	Use an appropriate integration time for the signal level.
	RF pickup	Noise varies with cable position, status of neighboring equipment.	Check integrity of outer screens of signal cables.
	Line voltage pickup	Noise level drops sharply if integration period is 16.7 msec (60 Hz) or 20 msec (50 Hz)	Keep I3200 and signal cables clear of unscreened high current mains voltage. Use integration periods (N/line frequency).
No signal	Small signal lost in noise		Use longer integration time.
Signal does not vary as expected	Integrators are overrange.	Overrange flags are set, signal recovers if integration period is reduced.	Reduce the integration period or use the larger feedback capacitor.
Measured currents or charges are inaccurate by up to 15%	Unit not calibrated.		Calibrate.
	Calibration was carried out while a signal current was present.	Internal calibration source does not measure as 500nA with all inputs disconnected.	Repeat calibration with no external signal present.
Inaccurate measurements for short integration times	Cable capacitance is affecting measurement	Reduce capacitive load or use larger feedback capacitor.	Reduce capacitive load or use larger feedback capacitor.
High background offset current	Unit is overheating due to failed fan	Unit feels warm. Fan stopped.	Return unit for fan replacement.

	Unit is overheating due to airflow blockage	Unit feels warm. Performance improves when operated on the bench.	Clear space around the unit and improve airflow.
	Various causes		Refer to section 25.
500 nA or 83.3 nA background on one channel	Internal calibration source has been turned on.		Turn off calibration source.
I3200 stops measuring	Trigger points limit reached.	Measurement starts again if I3200 is reinitialized.	Adjust trigger points as required.
	Communication link timeout		Investigate and fix communications issue. Use a longer timeout setting.
No or incorrect response to external trigger or gate	Incorrect gate polarity selected.		Use correct polarity.
	I3200 not configured to respond to external gate.		Use correct setup.
No or low high voltage	Shorted to ground in external circuit	Monitor HV reading zero or very low relative to setpoint. Monitor value recovers if I3200 disconnected from the external circuit.	Eliminate shorts to ground.
	Effective short to ground via free electrons	Monitor HV reading zero or very low relative to setpoint. Monitor value recovers if I3200 disconnected from the external circuit.	Reduce electron concentration if possible.
High voltage not at setpoint	A high compliance source such as a charged particle beam is driving the HV electrode.	Monitor value recovers if I3200 disconnected from the external circuit.	Change geometry to reduce beam strike.
Cannot set high voltage	Trying to set above the maximum allowed value soft limit.	Sets OK if a lower value is chosen.	If allowed, increase the maximum allowed value.

Unable to communicate with I3200	Wrong mode switch or address setting	Check mode switch setting against table in section 23 and address against expected address in host software.	Use correct switch settings. Switches can be changed while the unit is operating.
Unable to connect on fiber loop	Connector still fitted to RS232 or USB		Remove RS232 and USB connectors.
Communications interruptions	Other processes on PC host interfering with comms ports.		Use a dedicated PC with simple configuration and minimum number of processes running.
Unable to connect on USB	Missing or incorrect USB driver.	Device connected tone not heard when connecting the USB cable.	Install correct driver. Refer to the I3200 Software Manual.
Unable to connect on RS232	Another program is using the COM port.	Try to access the required port with Windows Hyperterminal.	Choose another port or close down the other program.
	Incorrect port settings.	Try to connect with the .htm file supplied with the unit.	Correct the settings.
	Incorrect cable.		Make up a suitable cable. See figure 9.
Incorrect dose delivered (-DQ option only)	Background not compensated.	Run accumulation without beam. Result should be low.	Repeat background compensation command and recheck. Investigate possible sources of variable background.
	Relationship between measured charge and dose in target not well known.	Check calibration.	Re-establish the charge to dose relationship.
	Beam delivery system not responding to beam on/off signal in a timely manner.	Check delays and variable response.	Make corrections as needed to connection to beam control system.

26 Maintenance

The I3200 does not require routine maintenance, except to clear any dust accumulation in the fan filter.

There is risk of contamination which may degrade performance if the case is opened. There are no user-serviceable parts inside.

! CAUTION: High voltages may be present inside the case. Do not open the case when power is applied.

If there is build up of dust in the filter, you should clear this by vacuum cleaning in situ, or by removing the filter element and cleaning it separately with an air jet. Note that detaching the filter element also detaches the fan from the case.



94 : Filter element removal

The I3200 is fitted with a 1.1 amp automatically resetting positive temperature coefficient (PTC) fuse in the 24 VDC input. No user intervention is required if the fuse operates due to overcurrent. The fuse will reset when the overcurrent condition ends.

27 Returns Procedure

Damaged or faulty units cannot be returned unless a Returns Material Authorization (RMA) number has been issued by Pyramid Technical Consultants, Inc. If you need to return a unit, contact Pyramid Technical Consultants at support@ptcusa.com³, stating

- model
- serial number
- nature of fault

An RMA will be issued, including details of which service center to return the unit to.

3. <mailto:support@ptcusa.com>

28 Support

Technical support in English language is available from Pyramid Technical Consultants, Inc. in the USA (+1 781 402 1700, Eastern Time Zone) and from Pyramid Technical Consultants Europe Ltd (+44 1273 492001, UK Time Zone).

Manual and software driver updates are available for download from the Pyramid Technical Consultants website at www.ptcusa.com⁴. Technical support is available by email from support@ptcusa.com⁵. Please provide the model number and serial number of your unit, plus relevant details of your application.

4. <http://www.ptcusa.com/>

5. <mailto:support@ptcusa.com>

29 Disposal

We hope that the I3200 gives you long and reliable service. The I3200 is manufactured to be compliance with the European Union RoHS Directive 2002/95/EC, and as such should not present any health hazard. Nevertheless, when your device has reached the end of its working life, you must dispose of it in accordance with local regulations in force. If you are disposing of the product in the European Union, this includes compliance with the Waste Electrical and Electronic Equipment Directive (WEEE) 2002/96/EC. Please contact Pyramid Technical Consultants, Inc. for instructions when you wish to dispose of the device.

30 Declaration of Conformity

Declaration of Conformity

Issued by: Pyramid Technical Consultants, Inc.
1050 Waltham Street, Lexington MA 02421, USA

The undersigned hereby declares, on behalf of Pyramid Technical Consultants, Inc. that the referenced product conforms to the provisions as listed. Refer to the document: *Extension of testing and analysis to the PTC product line, December 10, 2007* and the *I400 Technical Construction File* for detailed testing information.

Product: I3200 32-Channel Charge Integrator

Year of initial manufacture: 2007

Applicable Directives: 73/23/EEC Low Voltage Directive:
Laws for electrical equipment within certain voltage limits

89/336/EEC – EMC Directive:
Laws relating to electromagnetic compatibility

Applicable Standards: IEC 610101:2002 (2nd Edition)
UL 61010-1:2004
EN 61326: 1997+A1:1998+A2:2001
EN 55011:1998, A2:2002
EN 61000-6-2:2001 – Electromagnetic Compatibility
Generic Standard, Immunity for Industrial Applications

Issuing Agencies: Safety: TUV Rheinland North America.
12 Commerce Rd, Newtown, CT 06470 USA

EMC: TUV Rheinland North America.
12 Commerce Rd, Newtown, CT 06470 USA

Applicable Markings: TUV, FCC, CE

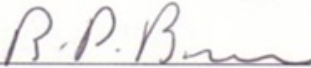
Authorized by: 
President, Pyramid Technical Consultants, Inc.

Date: 3 - Apr - 08

The Technical Construction File required by these Directives are maintained at the offices of Pyramid Technical Consultants, Inc, 1050 Waltham Street, Lexington MA 02421, USA
A copy of this file is available within the EU at the offices of Pyramid Technical Consultants Europe, Ltd, 2 Chanctonbury View, Henfield BN5 9TW, United Kingdom.