

# Prosthetics 2019 / 2020

Upper limbs

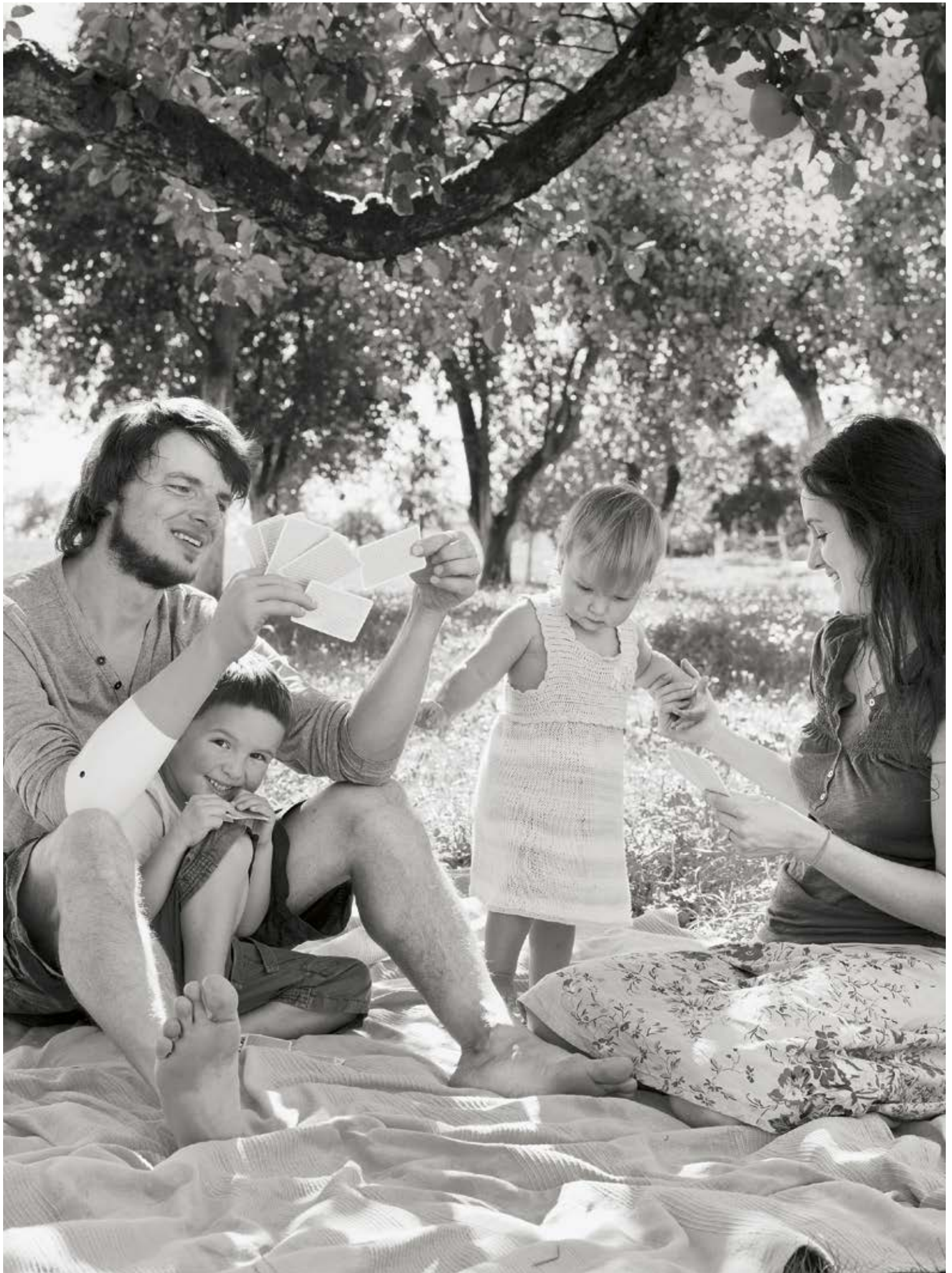



# Table of contents

## 1 | Always at your service!

Explanation of symbols and hazardous substances.....	6
--	---

## 2 | MyoBock Fittings for children

Overview of the MyoBock children's system.....	10
Electric Hand 2000.....	11
Prosthetic gloves and accessories.....	12
Lamination ring and accessories.....	15
Battery management and accessories.....	17
Control elements and accessories.....	19
Elbow components and accessories.....	21
Electrodes and accessories.....	24
Tools.....	28

## 3 | MyoBock Prosthesis solution

Transradial System.....	32
Transhumeral System.....	33
bebionic hand and accessories.....	34
Myo Plus pattern recognition and accessories.....	40
MyoHand VariPlus Speed.....	42
SensorHand Speed.....	48
System Electric Hands and accessories.....	51
Myo terminal device.....	54
System Electric Hands and accessories.....	57
Prosthetic gloves and accessories.....	60
System Electric Greifer.....	65
Wrist joints and accessories.....	66
DynamicArm.....	71
ErgoArm.....	76
Shoulder joints.....	79
Electrodes and accessories.....	80
Battery management and accessories.....	82
Cables and accessories.....	88
Control elements.....	91
Accessories.....	93
Software.....	94
Service parts.....	97

## 4 | Axon-Bus System

Michelangelo hand.....	102
AxonHook.....	103
Prosthetic gloves.....	104
Accessories.....	106
Rotation.....	107
AxonArm Ergo.....	108
Battery management.....	109
Electrodes and accessories.....	111
Control elements and accessories.....	112
Software.....	113
Tools.....	114

## 5 | Body-powered

Overview of active mechanical arm components.....	118
Passive system hand.....	119
Active system hands.....	120
Spare parts and accessories.....	122
Prosthetic gloves.....	125
Cable-activated hooks and accessories.....	128
Terminal devices.....	133
Wrist joints and accessories.....	134
Elbow components and accessories.....	138
Liners and accessories.....	146
Above-elbow & below-elbow harnesses with accessories.....	149

## 6 | Passive

Overview of passive mechanical arm components.....	158
Terminal devices and accessories.....	159
Prosthetic gloves.....	163
Adapter.....	166
Terminal device and colour determination.....	168
Terminal device and colour determination.....	171
Physolino baby hand and accessories.....	172
Passive prosthetic hands for children.....	174
Passive prosthetic hands for women.....	178
Passive prosthetic hands for men.....	186
Arm components.....	196
Shoulder joints and accessories.....	198
Elbow joint bars.....	204
Liners and accessories.....	206
Body harnesses and accessories.....	210

## 7 | Special tools

Special tools.....	224
Auxiliary materials.....	231

## Index

Index.....	236
Article number index.....	238









# Always at your service!

1

At Ottobock, we place great emphasis on customer service.

Our highly experienced representatives are standing by – ready to assist you with their comprehensive expertise, inform you about the latest developments, and advise you on every aspect of our products. For complex enquiries, our product experts and specialists in fabrication are there to help you. Our highly qualified team of field service employees can assist with special technical solutions and their on-site implementation. We also offer comprehensive service and marketing concepts.

Visit [www.ottobock.com](http://www.ottobock.com) to obtain up-to-date product information at any time.

How to reach us –  
Monday through Friday, 8 am to 5 pm  
T +49 5527-848-3411  
F +49 5527-848-1414  
[prothetik@ottobock.de](mailto:prothetik@ottobock.de)

# ▶ Explanation of symbols and hazardous substances

## Explanation of symbols

	Information sheet, poster
	Information material
	Instructions for processing or use
	Products with these symbols are registered trademarks in their respective countries.
	Miniaturisation
	Enlargement
	Mixing ratio
	Two components: A-component, B-component
	Self-adhesive
	Adhesive on both sides
	Washable at 40°C, gentle cycle
	Washable at 60°C
	Knowledge and application







## Explanations of hazardous substance symbols (R/S phrases)\*

	Xi=Irritant
	Xn=Hazardous to health
	O=Oxidising
	F=Highly flammable
	F+=Extremely flammable
	N=Environmentally hazardous
	C=Corrosive
	T=Toxic

\* The hazardous substance symbols (R/S phrases and P/H phrases) printed in the catalogue correspond to the labelling requirements for hazardous substances at the time of printing. They refer to the raw material. Changes reserved.

# ▶ Explanation of symbols and hazardous substances

## Explanations of hazardous substance symbols (P/H phrases)\*

	Hazard classes	Hazard categories
	Inflammable gases	1
	Inflammable aerosols	1, 2
	Inflammable liquids	1, 2, 3
	Inflammable solids	1, 2
	Self-decomposing substances and mixtures	Types B, C, D, E, F
	Pyrophoric liquids	1
	Pyrophoric solids	1
	Substances and mixtures capable of self-heating	1, 2
	Substances and mixtures that release inflammable gases upon contact with water	1, 2, 3
	Organic peroxides	Types B, C, D, E, F
	Oxidising gases	1
	Oxidising liquids	1, 2, 3
	Oxidising solids	1, 2, 3
	Corrosive effect on metal	1
	Caustic	1A, 1B, 1C
	Severe eye damage	1
	Acute toxicity (oral, dermal, inhalative)	1, 2, 3
	Acute toxicity (oral, dermal, inhalative)	4
	Skin irritation	2
	Eye irritation	2
	Skin sensitisation	1
	Specific target organ toxicity (one-time exposure)	3
	Respiratory system irritation	
	Anaesthetic effects	
	Respiratory tract sensitisation	1
	Germ cell mutagenicity	1A, 1B, 2
	Carcinogenicity	1A, 1B, 2
	Reproductive toxicity	1A, 1B, 2
	Specific target organ toxicity (one-time exposure)	1, 2
	Specific target organ toxicity (repeated exposure)	1, 2
	Aspiration hazard	1
	Hazardous to water	
	– Acutely hazardous to water	1
	– Chronically hazardous to water	1, 2

\* The hazardous substance symbols (R/S phrases and P/H phrases) printed in the catalogue correspond to the labelling requirements for hazardous substances at the time of printing. They refer to the raw material. Changes reserved.







# MyoBock Fittings for children

2

## Exploring the world

Fittings for children have always represented a major medical technology challenge, because children have special requirements in terms of functionality, flexibility and mobility. This is why it is important to offer a system that meets the individual needs of various age groups while simultaneously preparing the children for a future fitting with the system for adults.

The innovative 7.4 volt system for children achieves these objectives. In combination with the Electric Hand 2000, the MyolinoWrist 2000 and the MyolinoSkin Natural glove, it uses myoelectric components from the adult segment in order to establish the foundation for a flowing transition in the prosthetic fitting process. The 12K12 MovolinoArm Friction is the perfect complement to the Ottobock portfolio for upper arm prostheses in children aged 3 to 5 years.

### On the following pages you will find

- Overview of the MyoBock children's system
- Electric Hand 2000
- Prosthetic gloves
- Lamination ring
- Battery management
- Control elements
- Elbow components
- Electrodes
- Tools



You can find our order forms  
in the download centre under

[www.ottobock.de/downloadcenter/](http://www.ottobock.de/downloadcenter/)

# Overview of the MyoBock children's system

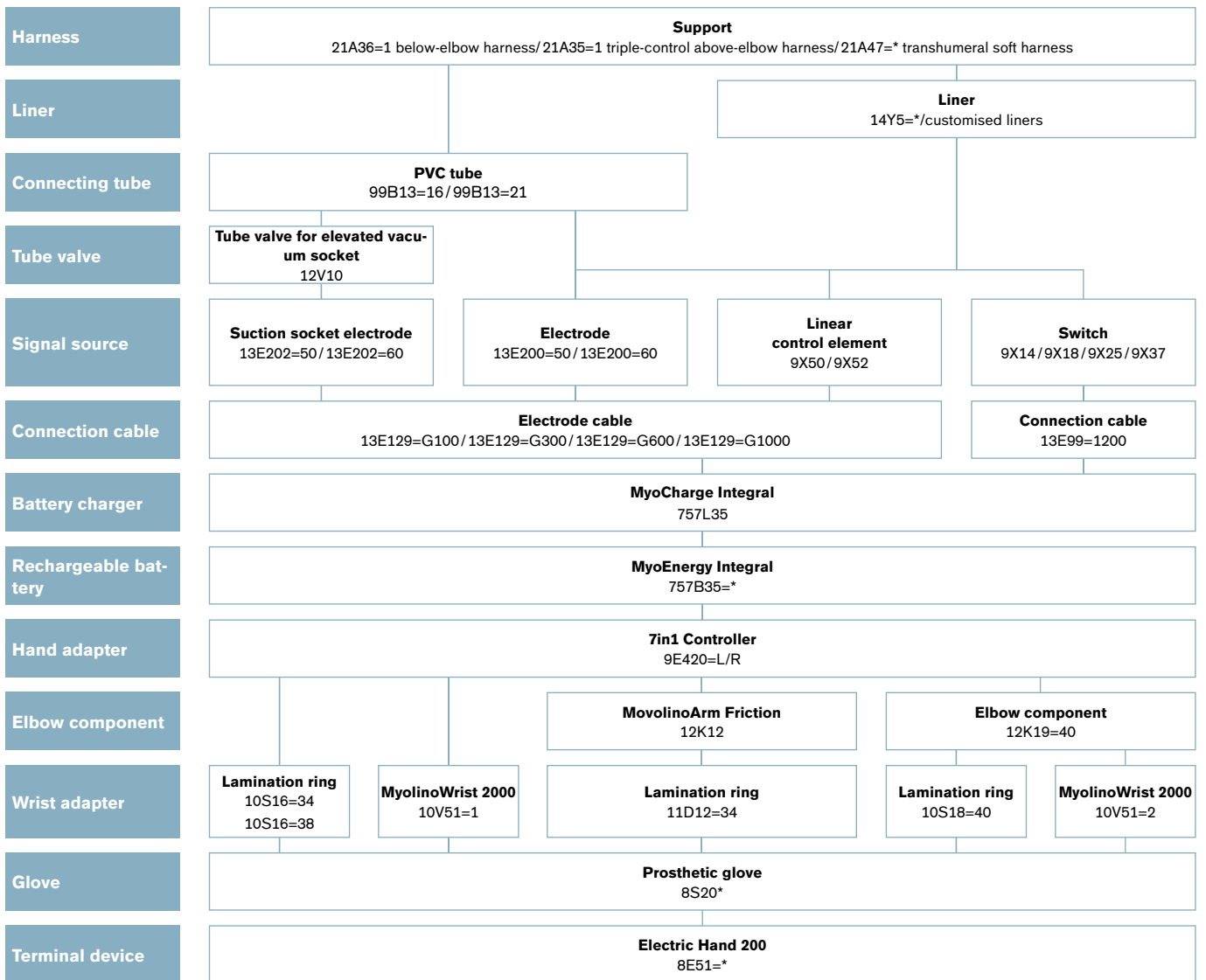



# ▶ Electric Hand 2000

## Electric Hand 2000

Art. no. 8E51

The Electric Hand 2000 can be used for children's hand prostheses with 7.4 V, making it suitable for nearly all residual limb lengths.

### Key features

- For MyoBock system with 7in1 Controller
- With finger filler (article no. 9E347=\*)
- Passive hand rotation and central sliding contact
- Without prosthetic glove, controller and lamination ring
- Available in four sizes:
  - Size 5 (for children aged 1½ to 3 years)
  - Size 5½ (for children aged 3 to 6 years)
  - Size 6 (for children aged 5 to 10 years)
  - Size 6½ (for children aged 8 to 13 years)

Art. no.	Side	Size	Lamination ring	Prosthetic glove
8E51=L5	Left (L)	5	10S16=34	8S20(N)=136X41L
8E51=L5 ½	Left (L)	5½	10S16=34	8S20(N)=147X45L
8E51=L6	Left (L)	6	10S16=38	8S20(N)=162X56L
8E51=L6 ½	Left (L)	6½	10S16=38	8S20(N)=177X64L
8E51=R5	Right (R)	5	10S16=34	8S20(N)=136X41R
8E51=R5 ½	Right (R)	5½	10S16=34	8S20(N)=147X45R
8E51=R6	Right (R)	6	10S16=38	8S20(N)=162X56R
8E51=R6 ½	Right (R)	6½	10S16=38	8S20(N)=177X64R



646D326=D  
646D442=DE

647H58

## ▶ Prosthetic gloves and accessories



646D423

647G571

Special cleaner for prosthetic gloves is found on page 14.

### MyolinoSkin Natural

Art. no. 8S20N

In addition to the standard prosthetic glove, Ottobock also offers additional models of the Skin Natural series. The multilayer structure of the gloves gives them a depth effect so that they have a very vivid appearance. The outer translucent layer allows the coloured fibres of the material to shine through. This simulates the natural vein structure of human skin. Please add an N before the = in the article number.

#### Example

- 8S20=136x41L4 (standard glove)
- 8S20N=136x41L4 (MyolinoSkin Natural)

The PVC-based material ensures that Skin Natural is very robust compared to other materials and it has a relatively long life. This provides safety when using the gloves. Due to a special modern surface treatment, the Skin Natural gloves are also easy to clean.

Art. no.	Side	Size	Sleeve length	Sleeve end circumference
8S20N=136X41L	Left (L)	5	210 mm	200 mm
8S20N=147X45L	Left (L)	5½	215 mm	200 mm
8S20N=162X56L	Left (L)	6	220 mm	210 mm
8S20N=177X64L	Left (L)	6½	240 mm	220 mm
8S20N=136X41R	Right (R)	5	210 mm	200 mm
8S20N=147X45R	Right (R)	5½	215 mm	200 mm
8S20N=162X56R	Right (R)	6	220 mm	210 mm
8S20N=177X64R	Right (R)	6½	240 mm	220 mm

Notice: The 8S20N=\* gloves are available in colours 2, 4, 6, 8, 11, 14 and 16. The 646M47 colour sample set helps to find the right shade.



646D49

647G468

### Prosthetic glove for children

Art. no. 8S20

The prosthetic glove for children impresses with its natural appearance, durability and flexibility.

Art. no.	Side	Size	Sleeve length	Sleeve end circumference
8S20=136X41L*	Left (L)	5	210 mm	200 mm
8S20=147X45L*	Left (L)	5½	215 mm	200 mm
8S20=162X56L*	Left (L)	6	220 mm	210 mm
8S20=177X64L*	Left (L)	6½	240 mm	220 mm
8S20=136X41R*	Right (R)	5	210 mm	200 mm
8S20=147X45R*	Right (R)	5½	215 mm	200 mm
8S20=162X56R*	Right (R)	6	220 mm	210 mm
8S20=177X64R*	Right (R)	6½	240 mm	220 mm

Notice: The 8S20=\*=\* gloves are available in 18 colours. The 646M3 colour scale helps to find the right shade.

## ▶ Prosthetic gloves and accessories

### Prosthetic glove for children

Art. no. 8S20

Just like their parents, our youngest users value the high quality of their prosthetic gloves. That is why our standard prosthetic gloves are very robust and flexible. In addition, the coloured gloves for the Electric Hand 2000 are now available for an eye-catching appearance in everyday life: Nine new colours are now offered for selection.

#### Benefits

- Suitable for girls and boys
- Mechanical strength makes them durable, robust and tear-resistant with minimal abrasion
- Used in combination with the Electric Hand 2000
- Clean with special cleaner (article no. 640F12) and pump sprayer (article no. 640F13)

Art. no.	Side	Size	Sleeve length	Sleeve end circumference
8S20=136X41L*	Left (L)	5	210 mm	200 mm
8S20=147X45L*	Left (L)	5½	215 mm	200 mm
8S20=162X56L*	Left (L)	6	220 mm	210 mm
8S20=177X64L*	Left (L)	6½	240 mm	220 mm
8S20=136X41R*	Right (R)	5	210 mm	200 mm
8S20=147X45R*	Right (R)	5½	215 mm	200 mm
8S20=162X56R*	Right (R)	6	220 mm	210 mm
8S20=177X64R*	Right (R)	6½	240 mm	220 mm

- Notice: The 8S20=\* gloves are available in 18 skin colour tones (646M3 colour sample set) and 9 additional bright colours (646M79 colour sample set).
- Notice: Please add the colour code following the article no., e.g., 8S20=136X41L30.



646D49

647G468



## ▶ Prosthetic gloves and accessories



### Special cleaner

Art. no. 640F12

In case of heavy soiling, the special cleaner for prosthetic gloves should be applied immediately (net contents: 460 g).



### Pump sprayer

Art. no. 640F13

The user should always keep a pump sprayer filled with special cleaner for Ottobock prosthetic gloves handy in order to be able to use the cleaner immediately in case of soiling (net contents: 90 g).

⦿ This container is empty on delivery!



### Donning spray

Art. no. 640F18

The donning spray for silicone liners and prosthetic gloves (silicone or PVC) is used among other things for the donning and removal of the liner or prosthetic glove.

Art. no.	Contents
640F18	90 ml
640F18=900	900 ml (refill)

## ▶ Lamination ring and accessories

### Lamination ring, complete

Art. no. 10S16

The lamination ring (article no. 10S16=\*) connects the Electric Hand 2000 (article no. 8E51) to the individually fabricated forearm socket. Relatively long below-elbow residual limbs can be fitted thanks to the low structural height since the lamination ring is laminated directly into the outer socket. The desired friction can be optimally adapted to the needs of the prosthesis wearer with the O-rings included in the scope of delivery. This permits a complete rotation of the Electric Hand 2000 (article no. 8E51).

#### O-rings (article no. 627F3)

- 1 pc. 627F3=26X1.0 (internal diameter: 26 mm, thickness: 1.0 mm)
- 1 pc. 627F3=19X1.5 (internal diameter: 19 mm, thickness: 1.5 mm)
- 1 pc. 627F3=16X1.5 (internal diameter: 16 mm, thickness: 1.5 mm)
- 1 pc. 627F3=11X1.5 (internal diameter: 11 mm, thickness: 1.5 mm)

Art. no.	Diameter	Size
10S16=34	34 mm	5 and 5½
10S16=38	38 mm	6 and 6½



### MyolinoWrist 2000

Art. no. 10V51

The MyolinoWrist 2000 (article no. 10V51=\*) is a mechanical ball wrist joint with adjustable friction. When combined with the Electric Hand 2000 (article no. 8E51), the hand can be positioned in any direction, largely avoiding compensating movements of the arm. The additional degrees of freedom make motion sequences appear more natural. At the same time, the wrist joint promotes a physiologically correct posture.

Art. no.	Wrist connection diameter	Weight	Overall length
10V51=1	40 mm	47 g	32 mm
10V51=2	40 mm	50 g	40 mm



 647G460

### O-ring

Art. no. 627F13=25X2

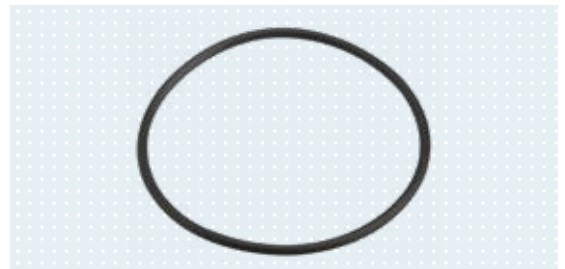

## ▶ Lamination ring and accessories



### Lamination ring set

Art. no. 11D61

The lamination ring set is compatible with the MyolinoWrist (article no. 10V51=1).

#### Set consisting of

- 1x lamination ring (article no. 11D3)
- 1x lamination dummy (article no. 11D9)
- 3x countersunk head screw (article no. 501S101=M3X8-KL-1)



### Lamination ring set

Art. no. 11D21

The lamination ring set is compatible with the MyolinoWrist (article no. 10V51=2).

#### Set consisting of

- 1x lamination ring (article no. 11D2)
- 1x lamination dummy (article no. 11D9)
- 3x countersunk head screw (article no. 501S101=M3X8-KL-1)



#### The right tools!

Adjustment tools are found on pages 28–29 in this catalogue!



## ▶ Battery management and accessories

### MyoEnergy Integral

Art. no. 757B35=\*

The MyoEnergy Integral (article no. 757B35=\*) is an integrated power supply system made up of several components. The charging receptacle has contacts for the battery, indicates the current charge level and allows the prosthesis to be switched on and off and opened in an emergency. The communication cable with a 3-pin receptacle is used for the exchange of data.

The supply cable establishes the connection between the battery and the respective prosthetic component. The battery consists of two cells with different capacities. Suitable for the MyoBock system.

#### Consisting of

- Lamination dummy, battery
- Lamination dummy for charging receptacle
- Drilling template for charging receptacle

Technical data	Art. no. 757B35=0	Art. no. 757B35=1
Capacity	300 mAh	600 mAh
Approx. output voltage	7.4 V	7.4 V
Approx. charging time	2.5 h	2.5 h
Technology	Lithium polymer	Lithium polymer
Dimensions approx.	35 x 20 x 20 mm	2x 52 x 25 x 10 mm

- The dummy sets for article no. 757B35=0, 757B35=1, 757B35=3, 757B35=5 can be ordered via the article no. 757Z276=\*

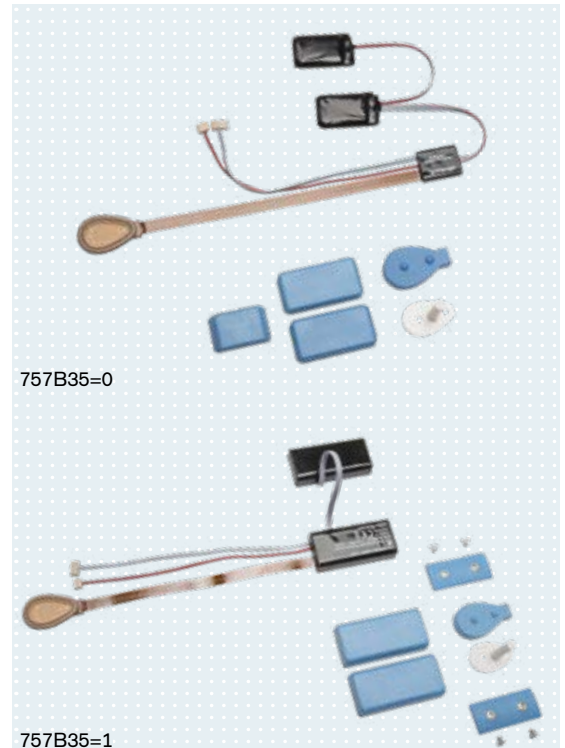

## ▶ Battery management and accessories



647G534

### MyoCharge Integral

Art. no. 757L35

The MyoEnergy Integral integrated into the socket is charged using the MyoCharge Integral (article no. 757L35). This is done by simply connecting the charging plug to the charging receptacle on the outside of the socket. Thanks to an integrated magnet, the charging plug can be easily attached to the charging receptacle. The special contour of the charging receptacle and charging plug assures the quick, reliable positioning of the two components to each other. LEDs indicate the readiness of the battery charger and the current battery charge level.

#### Technical data

Operating temperature	0 to +60°C
Storage temperature	-20 to +60°C
Supply voltage	100–240 V
Mains frequency	50–60 Hz

- ▶ The MyoCharge Integral can be used for all versions of the MyoEnergy Integral (article no. 757B35=0, 757B35=1 and 757B35=3).
- ▶ The universal power supply (article no. 757L16-4) is included in the scope of delivery!

## ▶ Control elements and accessories

### 7in1 Controller

Art. no. 9E420

The 7in1 Controller (article no. 9E420) is a control system with 7.4 volt for the Electric Hand 2000 that processes muscle signals and sends them to the prosthetic hand. The 7in1 Controller provides seven programs, some of which have been adopted from the adult system. Children benefit from the diverse possibilities: Individual adjustment of the prosthetic hand and simultaneous preparation for the adult system.

#### Choice of seven program versions

- DMC plus: Control with 2 electrodes
- DMC LowInput: Control with 2 electrodes
- AutoControl LowInput: Control with 2 electrodes
- DigitalControl: Control with 2 electrodes
- VarioControl: Control with 1 electrode
- DoubleChannel: Control with 1 electrode
- EVO Digital: Control with 1 electrode

#### Power supply

Power is supplied to the 7in1 Controller and the prosthetic components by the MyoEnergy Integral battery system (article no. 757B35=\*).

Art. no.	Length
9E420=L	Left (L)
9E420=R	Right (R)

- The contact plate (article no. 9E414) is included in the scope of delivery!

### MyolinoLink

Art. no. 60X6

The MyolinoLink (article no. 60X6) is used for the wireless transfer of data between the 7in1 Controller and a PC with Bluetooth functionality. Patient-specific settings can therefore be changed without a cable connection. The MyolinoLink is connected to the charging receptacle of the MyoEnergy Integral prior to use. Integrated magnets secure the MyolinoLink to the charging receptacle. The range of the radio connection is about 5 metres.



646D442

647G595



## ▶ Control elements and accessories



647G578

### MyolinoSoft

Art. no. 560X3

In order to offer patient-specific controller settings, adjustment software is also being used for the first time in a hand system for children. Rather than using specified settings, it works with various parameters, such as the patient side, control program, switching threshold and gripping speed, which can be individually adjusted. This is especially advantageous for children due to their high mobility requirements.

The MyolinoSoft software (article no. 560X3) is designed for configuring the settings of the 7in1 Controller (article no. 9E420) and the Electric Hand 2000 connected to it. Seven program versions are available.



### BionicLink

Art. no. 60X5

The BionicLink PC (article no. 60X5) supports wireless data communication between Ottobock products with a Bluetooth interface (e.g. DynamicArm) and a PC with USB port or USB hub.

#### **The BionicLink is equipped with two LEDs**

- The green LED indicates that the device is ready for use
- The blue LED indicates that a proper connection has been established between the product and the PC

A proper connection between the Ottobock product and a PC can only be established using corresponding Ottobock software products (e.g. ElbowSoft).

## ▶ Elbow components and accessories

### Elbow components for children

Art. no. 12K19=40

Elbow component with manual elbow lock (10 locking positions in 8° increments) and an upper arm rotation joint (humeral rotation feature) with lamination ring. The elbow ball is made of beige plastic (corresponds to beige 2). The wrist connection has a diameter of 40 mm.

Art. no.	Upper arm connection diameter	Size	Colour	Length	Circumference
12K19=40	54 mm	6¾	Beige	approx. 250 mm	210 mm

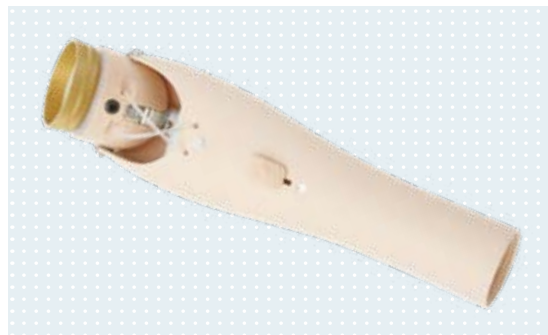

647G469

### MovolinoArm Friction

Art. no. 12K12

The MovolinoArm Friction is available in one size. It is the perfect complement to the current Ottobock product portfolio, since it allows use on the right and left side for children aged 3 to 5 years. The elbow is compatible with passive, body-powered and myoelectric arm prostheses and weighs a mere 182 g. The elbow has one friction setting for humeral rotation and one for flexion or extension of the forearm. Parents can easily set this friction setting. A further advantage is that the elbow is compatible with the components of the 7.4 volt system for children.

The MovolinoArm Friction features an appealing design that has a very realistic natural appearance.

The hand adapter of the MovolinoArm Friction is naturally compatible with the Electric Hand 2000. The wood adapter (article no. 10A40) is available for passive prostheses. The wrist joint, article no. 10V18=34 or 10V36=34, is compatible with body-powered prostheses.

Art. no.	Upper arm connection diameter	Wrist connection diameter
12K12	43.5 mm	34 mm

- ⦿ Please note that the elbow (article no. 12K12) can only be used with the following batteries: article no. 757B35=0 and 757B35=1!
- ⦿ Please note that one or two of the electrode cables, article no. 13E129=G100, are needed in addition!



647G570



#### Tip

Both joints can also be used in combination with the Electric Hand 2000 (article no. 8E51=\*).



## ▶ Elbow components and accessories

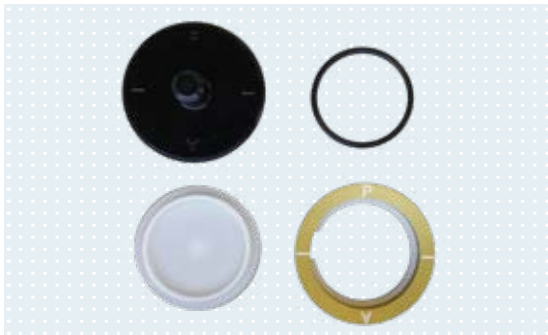

### Lamination ring set

Art. no. 13G21

The set consists of a lamination ring with lamination dummies and an O-ring.  
Notice: Only in combination with the 12K12 elbow.



### Lamination ring for children's forearm

Art. no. 10S18=40

The lamination ring for children's forearms makes it possible to combine an Electric Hand 2000 (article no. 8E51) with an elbow component for children (art. no 12K19=40).

To do so, the lamination ring with a diameter of 33 mm is glued directly into the elbow component using Orthocryl sealing resin compact adhesive (article no. 636K18=1).

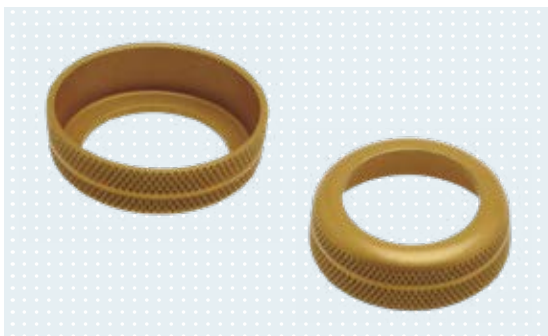

### Lamination ring

Art. no. 13G8=54

Notice: Only in combination with the 12K19=40 elbow.



### Special key

Art. no. 709Z9

The special key (article no. 709Z9) is used to tighten the counter nut. The counter nut may become damaged when tightening in a vice or, for example, with pliers.

## ▶ Elbow components and accessories

### Perlon cable

Art. no. 21A18

Art. no.	Diameter	Length	Order by
21A18=2X1	2 mm	1 m	linear metres
21A18=2X5	2 mm	5 m	linear metres
21A18=2X10	2 mm	10 m	linear metres
21A18=2X25	2 mm	25 m	linear metres

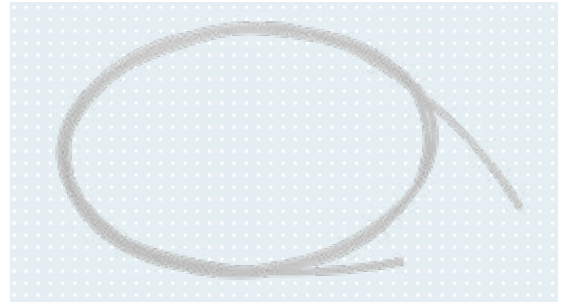

### Wrist joint lamination ring

Art. no. 11D12=34

The wrist joint lamination ring is used for the connection with the Children's Hand 2000. It consists of a copper friction ring, O-rings and a protective cover. Compatible with the elbow component article no. 12K12.



### Wood hand adapter

Art. no. 10A40

The wood hand adapter has a plastic threaded stud (M12X1.5) and is used to connect a passive inner hand to a forearm socket or elbow component. The diameter of the hand adapter is 60 mm, and modification to reduce that is possible.



### Ottobock wrist joint

Art. no. 10V36=34

The Ottobock wrist joint has an exterior diameter of 34 mm, the thread 1/2"-20". Compatible with the elbow component article no. 12K12.



### Ottobock wrist joint

Art. no. 10V18=34

The Ottobock wrist joint has an exterior diameter of 34 mm, the thread M12X1.5. Compatible with the elbow component article no. 12K12.



## ▶ Electrodes and accessories

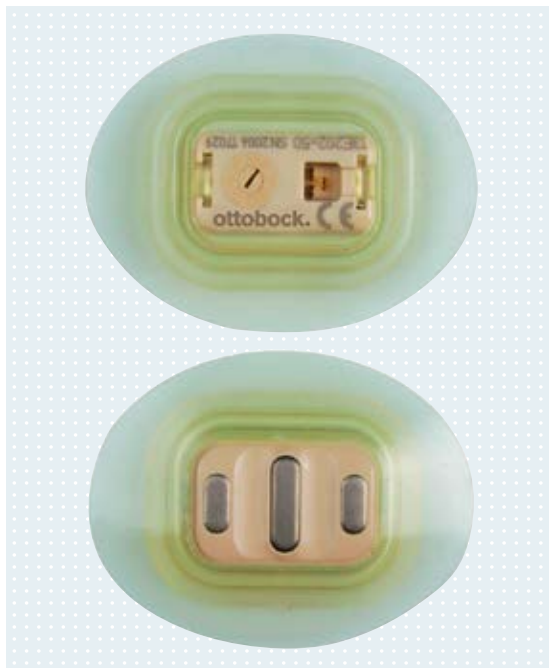

647G334

### Suction socket electrode

Art. no. 13E202

This generation of electrodes is based on the familiar 13E200 electrode. Embedded into a mounting suspension of elastic material, this electrode creates an airtight seal between the inner socket and outer socket. If used correctly, the suction socket electrode (article no. 13E202) also prevents perspiration from penetrating between the outer and inner socket, therefore effectively preventing damage to the electrical and mechanical components caused by corrosion.

The suction socket electrode can not only be used for standard sockets, but is also particularly suitable for application in elevated vacuum sockets. Combining the suction socket electrode with a tube valve (article no. 12V10) for an elevated vacuum socket creates a vacuum effect in the socket, optimising the hold of the residual limb in the socket. As with the 13E200 electrode, state-of-the-art shielding and filtering technologies largely protect the suction socket electrode (article no. 13E202) against high frequency interference caused, for example, by mobile phones, walkie-talkies, computers or anti-theft systems in shopping centres so that the proper control of the myoelectrically controlled prosthesis is not affected.

The electrode contacts are made from pure titanium and are therefore suitable for people with allergies as well.

Art. no.	HZ	Frequency bandwidth	Room temperature	Operating voltage U
13E202=50	50	90–450 Hz	-15 to +60°C	4.8–7.2 V
13E202=60	60	90–450 Hz	-15 to +60°C	4.8–7.2 V

- Use silicone grease (article no. 633F11) to seal the plug connection. Remove any excess grease after connecting the electrode cable.
- Tube valve (article no. 12V10), see page 91.



### Electrode

Art. no. 13E200

These MyoBock electrodes are particularly sensitive in the range of low muscle signals. The change in amplification now takes place logarithmically, which enables enhanced differentiation of the signal level. Thanks to modern frequency shielding and filtering technologies, they are less sensitive to low and high frequency interferences that are emitted, for example, by mobile phones or shopping centre security systems. The electrode contacts are made from pure titanium and are therefore suitable for people with allergies as well. The electrode accessories for laminated inner sockets (article no. 13E153) and for vacuum-formed inner sockets (article no. 13E201) are included in the scope of delivery. The frequency filter's full protection effect will only be provided if the mains frequency and filter frequency are identical.

Art. no.	HZ	Frequency bandwidth	Room temperature	Operating voltage U
13E200=50	50	90–450 Hz	-15 to +60°C	4.8–7.2 V
13E200=60	60	90–450 Hz	-15 to +60°C	4.8–7.2 V

- Use silicone grease (article no. 633F11) to seal the plug connection. Remove any excess grease after connecting the electrode cable.

## ▶ Electrodes and accessories

### Electrode accessories set

Art. no. 13E206

Suitable for suction socket electrodes (article no. 13E202).

#### Consisting of

- Casting template for inner socket (article no. 13E203)
- Lamination disc, serrated (article no. 507S15)
- Socket screw with Allen head (article no. 503F3)
- Sensitivity adjustment tool (article no. 13E80)
- Casting template for outer socket (article no. 13E204)



### Electrode accessories

Art. no. 13E153

For laminated inner sockets with 13E200 electrode. Use an Allen wrench (article no. 709S10=2) for socket screws (article no. 503F3).

#### Consisting of

- Template for inner socket (article no. 13E191)
- Casting template for outer socket (article no. 13E192)
- 2x lamination discs, serrated (article no. 507S15)
- 2x socket screws with Allen head (article no. 503F3)
- Sensitivity adjustment tool (article no. 13E80)

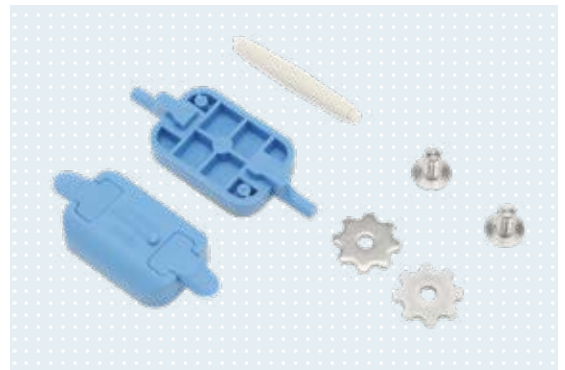

### Electrode accessories

Art. no. 13E201

For vacuum-formed inner sockets with electrode (article no. 13E200). Only available as a set. The electrode mounting brackets and setting nuts (article no. 29C5=M4X9) can also be ordered individually.

#### Consisting of

- One template for the inner and outer socket each
- Lamination dummy for electrode mounting bracket
- Electrode mounting bracket, beige (article no. 13E172)
- Setting nut (article no. 29C5=M4X9)

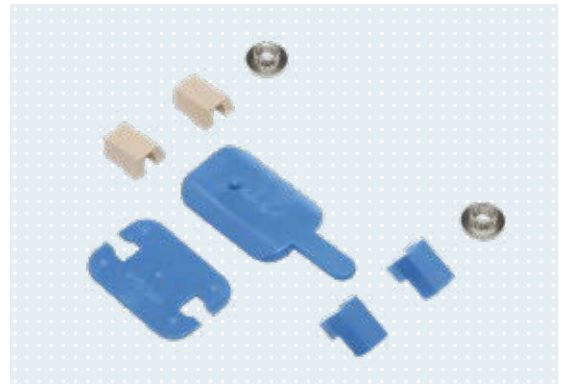

### Electrode mounting bracket set

Art. no. 13E135

The electrode mounting bracket set is intended for positioning and assembling MyoBock electrodes on the interim plaster or ThermoLyn socket (article no. 616T52 or 616T53), and is suitable for electrodes (article no. 13E200).



## ▶ Electrodes and accessories

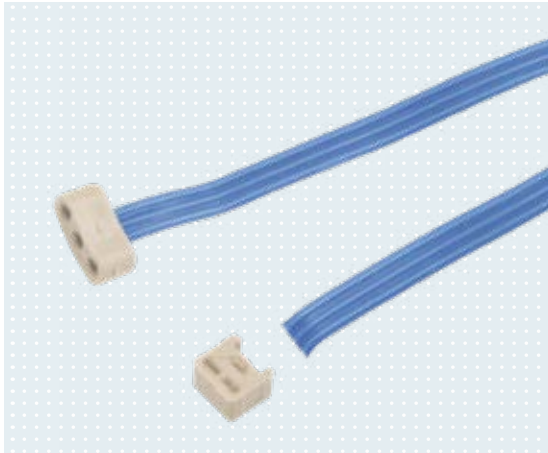

### Electrode cable with straight plug and plug connector

Art. no. 13E129=G\*

Electrode cable for connecting the electrode (article no. 13E200/13E202) or the control element (article no. 9X52, 9X53 and 9X54) with the 7in1 Controller (article no. 9E420) or the elbow joint (article no. 12K12).

Art. no.	Length
13E129=G100	100 mm
13E129=G300	300 mm
13E129=G600	600 mm
13E129=G1000	1,000 mm

• The plug connector (article no. 13E121) is included in the scope of delivery!



### Finger cover

Art. no. 9E342

Consisting of thumb, index finger and middle finger.

Art. no.	Size
9E342=5	5
9E342=5 ½	5½
9E342=6	6
9E342=6 ½	6½



### Finger filler

Art. no. 9E347

Used to fill the little and ring fingers in the prosthetic glove (article no. 8S20 and 8S20N).

Art. no.	Side	Size
9E347=L5	Left (L)	5
9E347=L5 ½	Left (L)	5½
9E347=L6	Left (L)	6
9E347=L6 ½	Left (L)	6½
9E347=R5	Right (R)	5
9E347=R5 ½	Right (R)	5½
9E347=R6	Right (R)	6
9E347=R6 ½	Right (R)	6½



## ▶ Electrodes and accessories

### EasyFit Arm donning sheath

Art. no. OC1560

The EasyFit Arm donning sheath with valve opening (colour: green) saves strength and time when putting on an arm prosthesis. It feels comfortable when donning. It is made of high-quality material and is therefore very durable. It is also easy to clean in the washing machine. Also available in children's sizes.

Art. no.	Size	Proximal residual limb circumference	Distal residual limb circumference	Sock length
OC1560=KIDS	KIDS	290 mm	150 mm	210 mm
OC1560=TR	TR	420 mm	220 mm	250 mm
OC1560=TH	TH	470 mm	280 mm	340 mm



646D536=M\_DE

#### Example of usage



1 The EasyFit Arm donning sheath must be spread out fully before use.

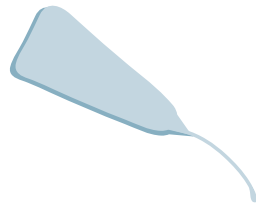

2 Pull half (of the length) of the EasyFit Arm donning sheath over itself up to the lower seam. The loop must face out.

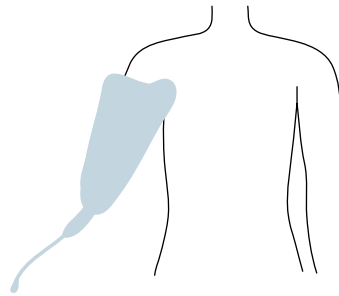

3 Pull the EasyFit Arm donning sheath like a sock over the residual arm, avoiding any wrinkles. Guide the socket over the residual limb so that the loop of the EasyFit Arm donning sheath can be pulled through the socket valve opening after applying the socket.

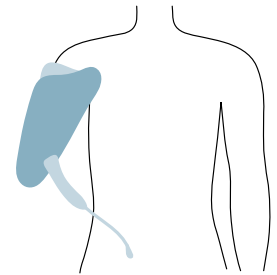

4 Finally, use the loop to slowly pull the EasyFit Arm donning sheath out of the prosthetic socket through the valve opening. If the residual limb is not properly positioned in the prosthetic socket, repeat the process.

### Derma Protection ArmComfort

Art. no. 453A1

Derma Protection ArmComfort makes the transition from the forearm socket to the upper arm more visually appealing and provides additional support for the prosthesis. The special polymer gel coating, high elasticity and anatomical fit also improve wearer comfort. Suitable for children (article no. 453A1=1) and adults (article no. 453A1).





## PVC connection tube

Art. no. 99B13

The PVC connection tube serves as a connection channel between the inner and outer sockets.

Art. no.	Colour	Diameter
99B13=16	Beige	16 mm
99B13=16-7	Black	16 mm
99B13=21	Beige	21 mm
99B13=21-7	Black	21 mm

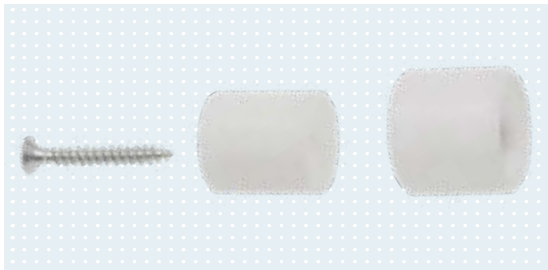

## Tube dummies

Art. no. 99B83

The tube dummies are used for fabricating vacuum-formed inner sockets.

Art. no.	Diameter
99B83=16	16 mm
99B83=21	21 mm

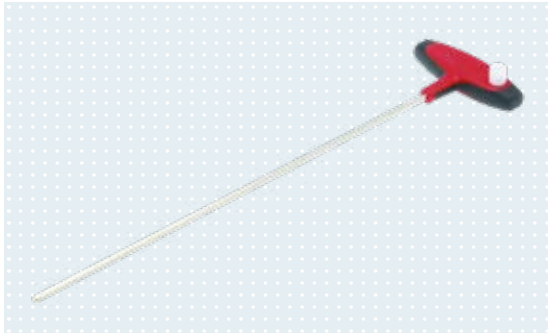

## Alignment rod

Art. no. 711M20

In combination with the mounting adapter (article no. 711M50-1), the alignment rod (hexagon) is suitable for installation and removal of the 7in1 Controller (article no. 9E420) or for inserting and ejecting the switching units (article no. 9E349 and 9E350).



## Mounting adapter

Art. no. 711M50-1

For installing the 7in1 Controller (article no. 9E420=\*) in combination with the alignment rod (article no. 711M20).

## Tools

### Alignment tool for children's component

Art. no. 743A19

Suitable for lamination rings (article no. 10S16).

**Consisting of:**

- Alignment rod (article no. 743Y167)
- Lamination dummy for sizes 5 and 5½ (article no. 743Y42=34)
- Lamination dummy for sizes 6 and 6½ (article no. 743Y42=38)

Art. no.	Thread	Diameter	Length
743A19	M8	12 mm	169 mm

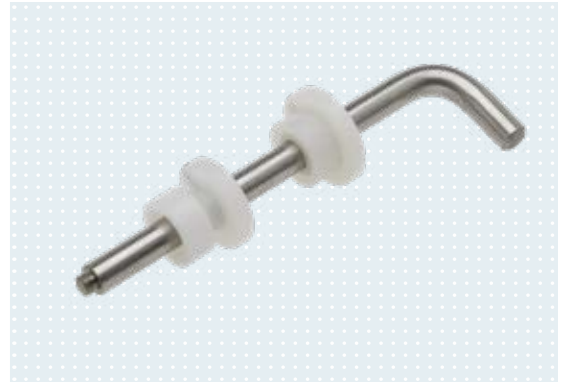

### Allen wrench

Art. no. 709S10=2

For socket screws (article no. 503F3) that connect the inner and outer socket.



### Allen wrench

Art. no. 709S42

Offset Allen key for adjusting the friction of the MyolinoWrist 2000 (article no. 10V51).









# MyoBock Prosthesis solution

## Best quality for an optimal fitting

As far back as the 1960s, Ottobock set international standards with the development of the System Electric Hand and has since placed great emphasis on quality in the further development of myoelectric hand and arm prostheses – for optimal, individual fittings.

A sensor integrated in the thumb of the SensorHand Speed prevents grasped objects from slipping out of the hand. This prosthetic hand also sets new standards in terms of gripping force and gripping speed together with the MyoHand VariPlus Speed. The DynamicArm, an electronically controlled, active elbow joint with an innovative drive system and continuous vario-gear, results in highly physiological movement. Combined with the hand-painted Skin Natural prosthetic gloves, a very natural appearance can be achieved.

### On the following pages you will find

- bebionic hand
- Myo Plus pattern recognition
- MyoBock adult system overview
- Terminal devices
- Prosthetic gloves
- System Electric Greifer
- Wrist joints
- Elbow components
- Shoulder joints
- Electrodes
- Battery management
- Cables
- Control elements
- Accessories
- Software
- Service parts



You can find our order forms  
in the download centre under

[www.ottobock.de/downloadcenter/](http://www.ottobock.de/downloadcenter/)

# Transradial System

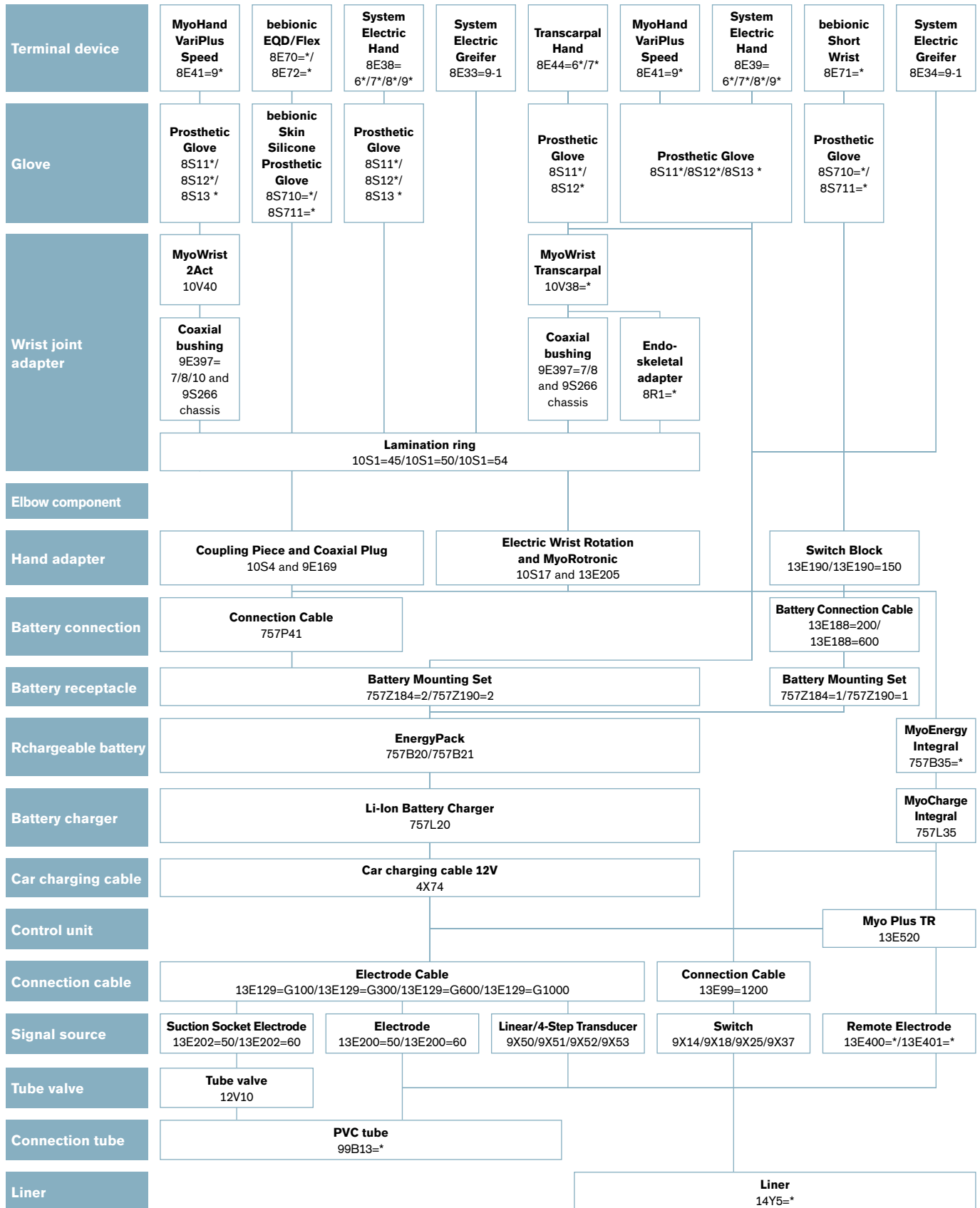

# ▶ Transhumeral System

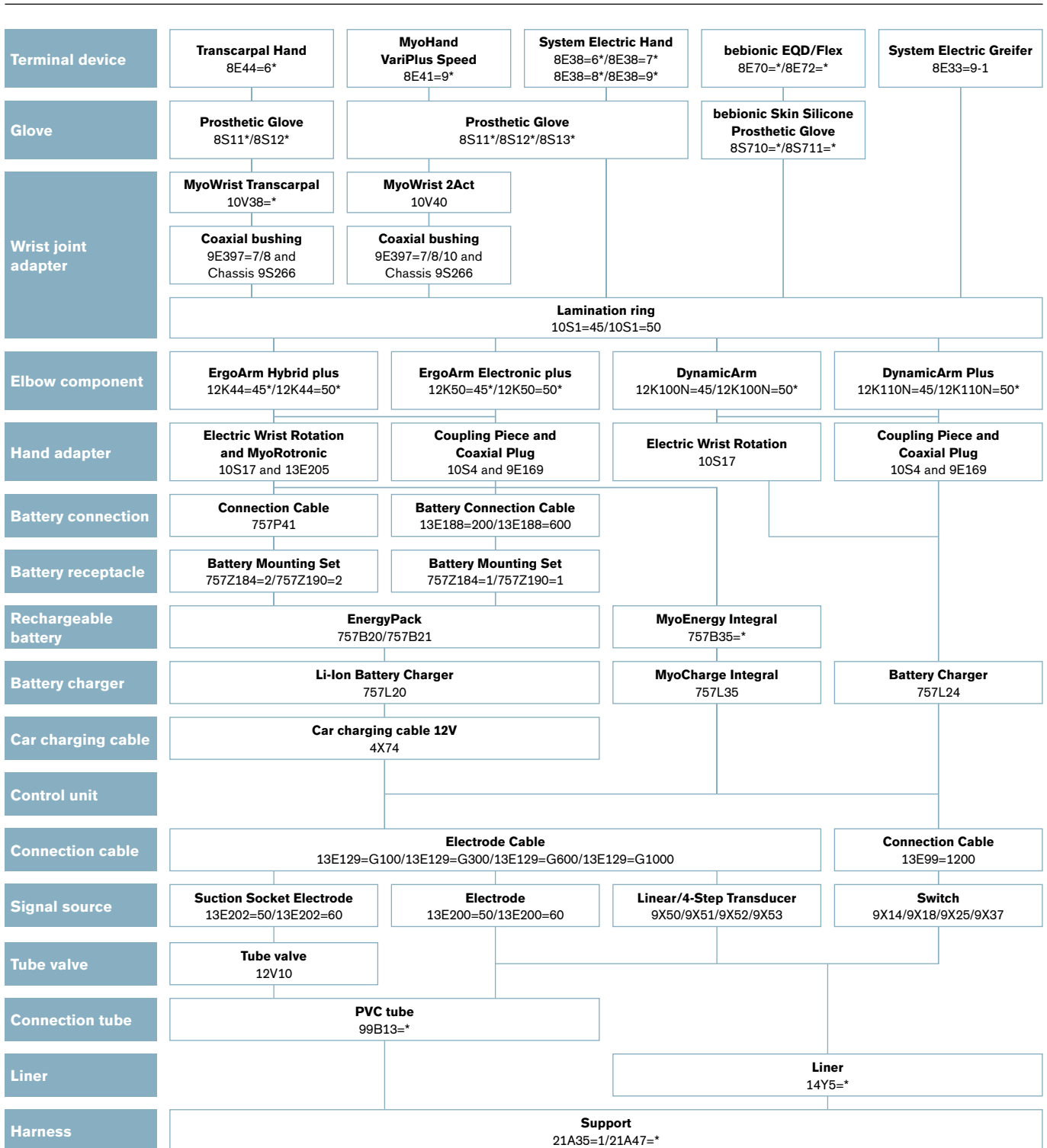

## ▶ bebionic hand and accessories

### bebionic hand

The bebionic hand is a myoelectrically controlled prosthetic hand that offers the user five individually powered, moveable fingers. Each finger and the thumb is driven by its own motor, allowing this hand to execute various grip patterns. The latest drive technology allows the integrated microprocessor to continuously control the finger position.

This makes it possible to reproduce all grip patterns precisely and also gives the hand a special feature, the Auto-Grip function. The bebionic is available in the sizes small and medium. The small hand is ideal for women and adolescents.



### bebionic hand

Each finger of the bebionic hand moves entirely naturally. Eight different grips can be controlled directly. The thumb of the bebionic hand can be positioned in two different basic positions. Like other myoelectric hand prostheses, it is easy to control. The appropriate glove is available in 8 different shades and in black.

Technical data	EQD 8E70=*	Short wrist 8E71=*	Flex wrist 8E72=*
Weight size S approx.	433 g	402 g	504 g
Weight size M approx.	616 g	588 g	689 g
Opening width	75 mm	75 mm	75 mm
Extension/flexion of the wrist	–	–	-40° to +40° in 20° increments
<b>Load limits</b>			
Force on single finger (static)	32 N		
Transverse force on single finger (static)	44 N		
Force on chassis (static)	500 N		
Force with closed hand (static)	152 N		
Forces on thumb (static)	40 N		

## ▶ bebionic hand and accessories

### bebionic hand EQD (Quick Disconnect)

Art. no. 8E70

The hand can be taken off with a rotating movement. The Quick Disconnect makes it possible for the user to quickly switch to other terminal devices.

#### Example

- 8E70=L-S-W (bebionic hand small with Quick Disconnect, left, white)
- 8E70=L-S-W (bebionic hand small with Quick Disconnect, left, black)

Art. no.	Side	Size	Colour
8E70=L-S*	Left (L)	Small	White, black
8E70=L-M-B	Left (L)	Medium	Black
8E70=R-S*	Right (R)	Small	White, black
8E70=R-M-B	Right (R)	Medium	Black



### bebionic hand short wrist (SW)

Art. no. 8E71

The short connection version for users with a long residual limb. The lamination ring is included in the scope of delivery. The hand can be rotated by the user with constant resistance. This resistance is adaptable.

#### Example

- 8E71=L-S-W (bebionic hand, small for short wrists with quick-release lock, left, white)
- 8E71=L-S-B (bebionic hand, small for short wrists with quick-release lock, left, black)

Art. no.	Side	Size	Colour
8E71=L-S*	Left (L)	Small	White, black
8E71=L-M-B	Left (L)	Medium	Black
8E71=R-S*	Right (R)	Small	White, black
8E71=R-M-B	Right (R)	Medium	Black





## ▶ bebionic hand and accessories



### bebionic hand flex wrist

Art. no. 8E72

The flex wrist joint allows the user to flex and extend the hand. The hand can be locked at an angle of 40° extension, 40° flexion and in the relaxed hand position.

#### Example

- 8E72=L-S-W (bebionic hand small with flex wrist joint, left, white)
- 8E72=L-S-B (bebionic hand small with flex wrist joint, left, black)

Art. no.	Side	Size	Colour
8E72=L-S-*	Left (L)	Small	White, black
8E72=L-M-B	Left (L)	Medium	Black
8E72=R-S-*	Right (R)	Small	White, black
8E72=R-M-B	Right (R)	Medium	Black

## ▶ bebionic hand and accessories

### bebionic Skin Silicone

Art. no. 8S711\*

The glove for the bebionic hand is made of several layers of silicone with integrated fibre reinforcement. Unique micro-pigmentation combined with additional details on the palms, knuckles and nails creates a natural appearance. Easy handling when donning and doffing, easy to clean. Eight different skin colours (02–16) are available. The colour black is offered in addition.

#### Example

- 8S711=L-S02 (silicone glove, small, left, colour 02)

Art. no.	Side	Size	Colour
8S711=L-S*	Left (L)	Small	02 – 16
8S711=L-M*	Left (L)	Medium	02 – 16
8S711=L-L*	Left (L)	Large	02 – 16
8S711=R-S*	Right (R)	Small	02 – 16
8S711=R-M*	Right (R)	Medium	02 – 16
8S711=R-L*	Right (R)	Large	02 – 16

- When ordering, please add the colour code according to the 646M82 colour sample set to the end of the article number.

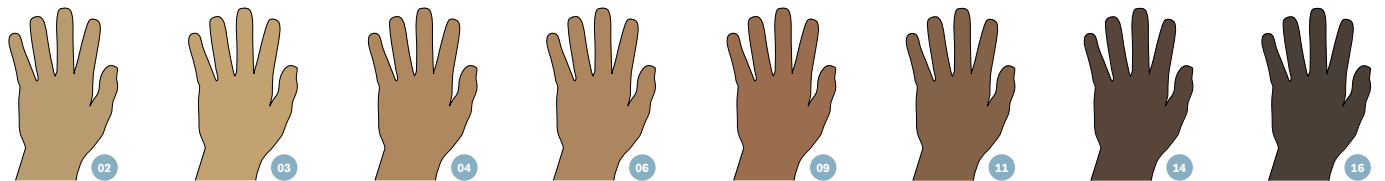

3

### bebionic Skin Silicone Black

Art. no. 8S710\*

Art. no.	Side	Size	Colour
8S710=L-S20	Left (L)	Small	Black
8S710=L-M20	Left (L)	Medium	Black
8S710=L-L20	Left (L)	Large	Black
8S710=R-S20	Right (R)	Small	Black
8S710=R-M20	Right (R)	Medium	Black
8S710=R-L20	Right (R)	Large	Black



## ▶ bebionic hand and accessories



### MyoEnergy Integral

Art. no. 757B35=\*

The MyoEnergy Integral (article no. 757B35=\*) is an integrated power supply system made up of several components. The charging receptacle has contacts for the battery, indicates the current charge level and allows the prosthesis to be switched on and off and opened in an emergency. The communication cable with a 3-pin receptacle is used for the exchange of data. The supply cable establishes the connection between the battery and the respective prosthetic component. The battery consists of two cells with different capacities. Suitable for the MyoBock system.

#### Consisting of

- Lamination dummy, battery
- Lamination dummy for charging receptacle
- Drilling template for charging receptacle

Technical data	757B35=3	757B35=5
Capacity	1,150 mAh	3,450 mAh
Voltage (nominal) approx.	7.4 V	7.4 V
Charging time	2.5 hours	3 hours
Dimensions (LxWxH) Battery cell	52x36x9 mm	79.5x20mm per battery cell (2 cells are installed)

- ◉ The dummy sets for article no. 757B35=3 and 757B35=5 can be ordered via the article no. 757Z276=\*.



647G534

### MyoCharge Integral

Art. no. 757L35

The MyoEnergy Integral integrated into the socket is charged using the MyoCharge Integral (article no. 757L35). Simply place the charging plug against the charging receptacle on the outside of the prosthetic socket. Thanks to an integrated magnet, the charging plug can be easily attached to the charging receptacle. The special contour of the charging receptacle and charging plug assures the quick, reliable positioning of the two components to each other. LEDs indicate the readiness of the battery charger and the current charge level.

#### Technical data

Operating temperature	0 to +60°C
Storage temperature	-20 to +60°C
Supply voltage	100–240 V
Mains frequency	50–60 Hz

- ◉ The MyoCharge Integral can be used for all versions of the MyoEnergy Integral (article no. 757B35=0, 757B35=1, 757B35=3 and 757B35=5).
- ◉ The power supply (article no. 757L16-4) is included in the scope of delivery!

## ▶ bebionic hand and accessories

### Joint fork

Art. no. 9S296

For the hands manufactured by Steeper, please use article no. B30977; article no. 9S296 for hands manufactured by Ottobock.

• 2 joint forks are included with the hand.



### Lamination ring

Art. no. 10S1

Lamination ring for myoelectric prosthetic hands such as bebionic hand, MyoBock hands, system electric hands (article no. 8E38) or electric greifer (article no. 8E33) with lamination tection cover for bonding.

Art. no.	Size
10S1=40	7
10S1=45	Small
10S1=50	Medium
10S1=54	Large



### Coaxial plug

Art. no. 9E169

Coaxial plug for connecting the two electrodes and the battery.

#### Consisting of

- Coaxial plug piece
- Lock ring (article no. 9E170)
- Oval head screw (article no. 501S50=M4X6)



### Coupling piece

Art. no. 10S4

Coupling piece with lock ring.



### Bluetooth long dongle

Art. no. BB33061

The Bluetooth long dongle is required for both sizes of Ottobock bebionic hands.



## ▶ Myo Plus pattern recognition and accessories

### The Myo Plus principle – a brief explanation

Myo Plus pattern recognition is the next generation of prosthesis control for the bionic hand and the MyoBock system. Myo Plus is a learning control system that can interpret the movement patterns in the user's residual limb. A certain prosthetic hand grip can be assigned to each movement pattern. This allows the user to control the prosthesis more intuitively and without switching.

Myo Plus pattern recognition aims to use intuitive, simple and repeatable movement patterns for prosthesis control in order to give the user back the natural feeling of the hand.

When a person thinks about a certain hand movement or grip, the brain sends corresponding signals to the muscles. The muscles then carry out the movement or grip. After an amputation, the hand is still mapped in the brain. Amputees can still imagine closing their hand. The signals are still sent as well, but the corresponding organ to carry out the command is missing.

Myo Plus prosthesis control uses eight electrodes to detect the incoming signals on the forearm, recognising patterns from them that are characteristic for individual movements. Complex decoding and amplification mechanisms transform and amplify these signals and patterns so that a prosthesis can translate them into a movement.





# ▶ Myo Plus pattern recognition and accessories

## Myo Plus TR

Art. no. 13E520

The Myo Plus TR control unit measures and interprets muscle activity in the residual limb through machine learning. Individual movement patterns are recognised and translated to prosthesis movements.

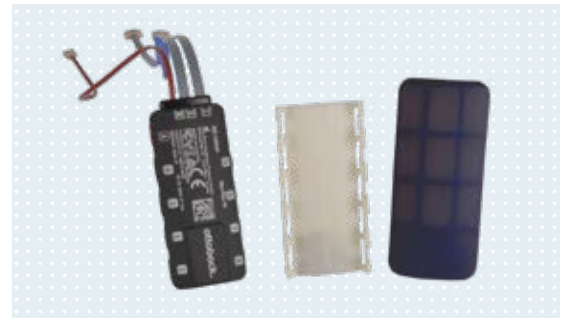

## Remote electrode

Art. no. 13E400=\*

Art. no.	Connection	Length	Frequency
13E400=G90-50	2-pin	90 mm	50 Hz
13E400=G90-60	2-pin	90 mm	60 Hz
13E400=G140-50	2-pin	140 mm	50 Hz
13E400=G140-60	2-pin	140 mm	60 Hz

◉ Notice: Six of the 13E400=\* remote electrodes are required per prosthesis.

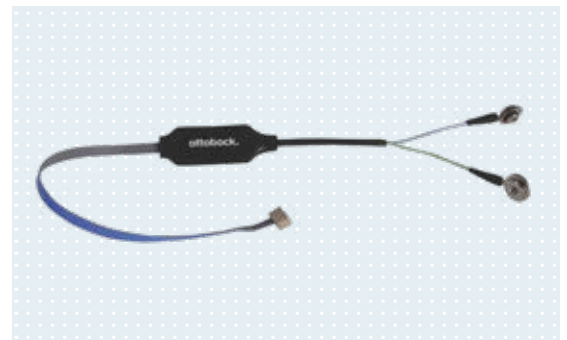

## Remote electrode

Art. no. 13E401=\*

Art. no.	Connection	Length	Frequency
13E401=G90-50	3-pin	90 mm	50 Hz
13E401=G90-60	3-pin	90 mm	60 Hz
13E401=G140-50	3-pin	140 mm	50 Hz
13E401=G140-60	3-pin	140 mm	60 Hz

◉ Notice: Two of the 13E401=\* remote electrodes are required per prosthesis.

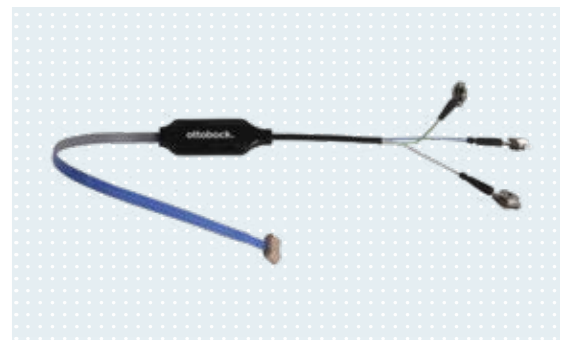

## Electrode dome

Art. no. 13Z161/13Z162/13Z163

Art. no.	Description
13Z161	Electrode dome, flat (package contents: 6 pcs), height: 2.2 mm
13Z162	Electrode dome, medium (package contents: 6 pcs), height: 3.5 mm
13Z163	Electrode dome, high (package contents: 6 pcs), height: 4.2 mm

◉ Notice: a total of 3 packing units (18 pcs) are needed per prosthesis.

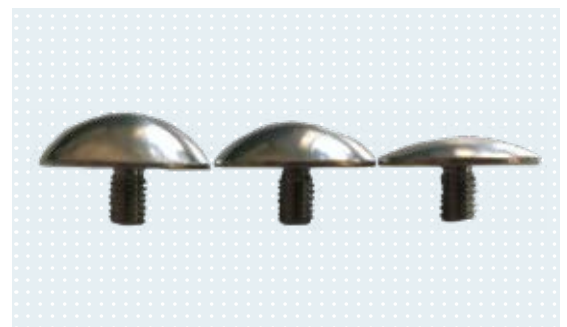

# ▶ MyoHand VariPlus Speed



646D165  
646D321=D

647G504



## MyoHand VariPlus Speed

Art. no. 8E38=9

The MyoHand VariPlus Speed with quick-disconnect wrist unit is a further development from Ottobock. It combines the mechanical characteristics of the SensorHand Speed and the control options of the DMC VariPlus System Electric Greifer. Thanks to the high gripping force (approx. 80 N) and speed (up to 300 mm/s), objects can be gripped quickly and precisely. A total of six different programmes can be selected and adapted according to patient indications using the MyoSelect (article no. 757T13). This permits optimum adaptation to the needs and abilities of the prosthesis user.

**The following control versions can be selected with the MyoSelect (article no. 757T13)**

- DMC plus (white)
- AutoControl LowInput (red)
- VarioControl (blue)
- VarioDual (yellow)

The MyoHand VariPlus Speed can be operated with the MyoEnergy Integral (article no. 757B35=\*), or the EnergyPack (article no. 757B20/757B21). With central coaxial plug connection, automatic shut-off electronics with integrated on-off switch, low-friction bevel gear, positive back lock and system inner hand. An integrated slip clutch makes opening possible in case of emergency.

Art. no.	Side	Size	Inner hand	User
8E38=9-L7¼	Left (L)	7¼	8X18=L7¼	Women, adolescents
8E38=9-L7¾	Left (L)	7¾	8X18=L7¾	Men
8E38=9-L8¼	Left (L)	8¼	8X18=L8¼	Men
8E38=9-R7¼	Right (R)	7¼	8X18=R7¼	Women, adolescents
8E38=9-R7¾	Right (R)	7¾	8X18=R7¾	Men
8E38=9-R8¼	Right (R)	8¼	8X18=R8¼	Men

### Technical data

Static current	1 mA
Operating temperature	0 to +70°
Opening width	100 mm
Proportional gripping force approx.	0–100 N
Proportional speed	15–300 mm/sec
Weight approx. (size 7¾)	482 g

- The electrodes must be adjusted with the MyoBoy (article no. 757M11)!
- For compatible prosthetic gloves, see pages 56–60.

# ▶ MyoHand VariPlus Speed

## MyoHand VariPlus Speed

Art. no. 8E39=9

The MyoHand VariPlus Speed with lamination ring is a further development from Ottobock. It combines the mechanical characteristics of the SensorHand Speed and the control options of the DMC VariPlus System Electric Greifer. Thanks to the high gripping force (approx. 80 N) and speed (up to 300 mm/s), objects can be gripped quickly and precisely. A total of six different programmes can be selected and adapted according to patient indications using the MyoSelect (article no. 757T13). This permits optimum adaptation to the needs and abilities of the prosthesis user.

**The following control versions can be selected with the MyoSelect (article no. 757T13)**

- DMC plus
- AutoControl LowInput
- VarioControl
- VarioDual
- DigitalControl
- DoubleChannel Control

The MyoHand VariPlus Speed can be operated with the MyoEnergy Integral (article no. 757B35=\*) or the EnergyPack (article no. 757B20/757B21). It features a centrally guided flat cable, automatic shut-off electronics with integrated on-off switch, low-friction bevel gear, positive back lock and system inner hand. An integrated slip clutch makes opening possible in case of emergency.

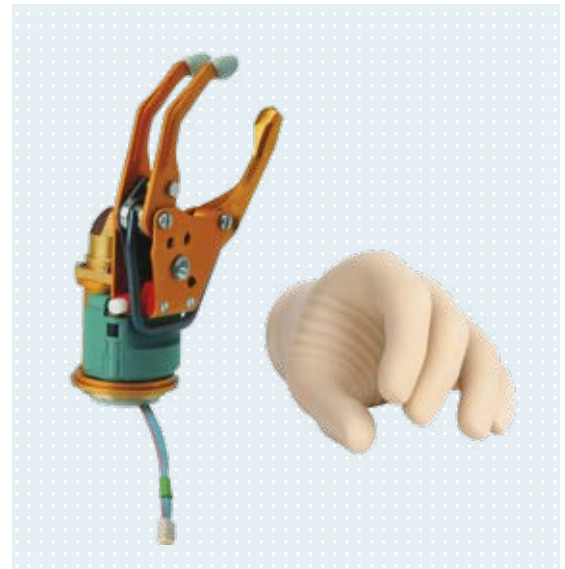

646D165  
646D321=D

647G504

Art. no.	Side	Size	Inner hand	User
8E39=9-L7¼	Left (L)	7¼	8X18=L7¼	Women, adolescents
8E39=9-L7¾	Left (L)	7¾	8X18=L7¾	Men
8E39=9-L8¼	Left (L)	8¼	8X18=L8¼	Men
8E39=9-R7¼	Right (R)	7¼	8X18=R7¼	Women, adolescents
8E39=9-R7¾	Right (R)	7¾	8X18=R7¾	Men
8E39=9-R8¼	Right (R)	8¼	8X18=R8¼	Men

### Technical data

Static current	1 mA
Operating temperature	0 to +70°
Opening width	100 mm
Proportional gripping force approx.	0–100 N
Proportional speed	15–300 mm/sec
Weight approx. (size 7¾)	446 g

- The electrodes must be adjusted with the MyoBoy (article no. 757M11)!
- For compatible prosthetic gloves, see pages 56–60.

# ▶ MyoHand VariPlus Speed

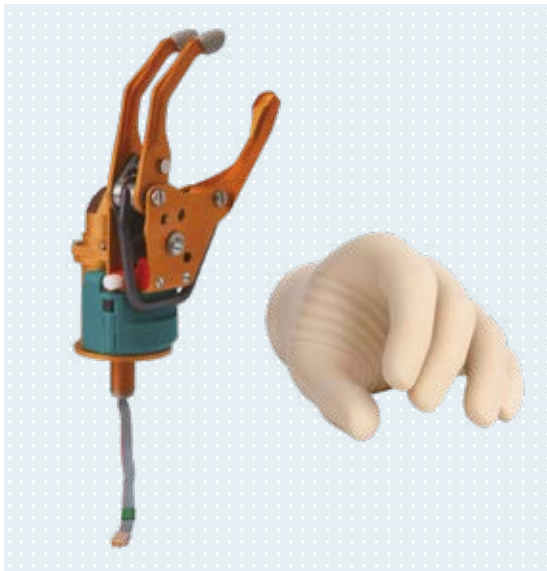

646D165  
646D321=D

647G504

## MyoHand VariPlus Speed

Art. no. 8E41=9

The MyoHand VariPlus Speed with M12X1.5 threaded stud is a further development from Ottobock. It combines the mechanical characteristics of the SensorHand Speed and the control options of the DMC VariPlus System Electric Greifer. Thanks to the high gripping force (approx. 80 N) and speed (up to 300 mm/s), objects can be gripped quickly and precisely. A total of six different programmes can be selected and adapted according to patient indications using the MyoSelect (article no. 757T13). This permits optimum adaptation to the needs and abilities of the prosthesis user.

### The following control versions can be selected with the MyoSelect (article no. 757T13)

- DMC plus
- AutoControl LowInput
- VarioControl
- VarioDual
- DigitalControl
- DoubleChannel Control

The MyoHand VariPlus Speed can be operated with the MyoEnergy Integral (article no. 757B35=\*), or the EnergyPack (article no. 757B20/757B21). It features a central cable outlet, automatic shut-off electronics with integrated on-off switch, low-friction bevel gear, positive back lock and system inner hand. An integrated slip clutch makes opening possible in case of emergency.

Art. no.	Side	Size	Inner hand	User
8E41=9-L7¼	Left (L)	7¼	8X18=L7¼	Women, adolescents
8E41=9-L7¾	Left (L)	7¾	8X18=L7¾	Men
8E41=9-L8¼	Left (L)	8¼	8X18=L8¼	Men
8E41=9-R7¼	Right (R)	7¼	8X18=R7¼	Women, adolescents
8E41=9-R7¾	Right (R)	7¾	8X18=R7¾	Men
8E41=9-R8¼	Right (R)	8¼	8X18=R8¼	Men

### Technical data

Static current	1 mA
Operating temperature	0 to +70°
Opening width	100 mm
Proportional gripping force approx.	0–100 N
Proportional speed	15–300 mm/sec
Weight approx. (size 7¾)	442 g

- ◉ The electrodes must be adjusted with the MyoBoy (article no. 757M11)!
- ◉ For compatible prosthetic gloves, see pages 56–60.





# ▶ MyoHand VariPlus Speed

Programme 1	Open	Close	Indication
DMC plus	<ul style="list-style-type: none"> <li>• Sustained electrode signal</li> <li>• Speed: proportional</li> <li>• Adjustment regulator A</li> </ul>	<ul style="list-style-type: none"> <li>• Sustained electrode signal</li> <li>• Gripping force: proportional. After gripping once with maximum force, the EMG signal required to open the hand will be set to a higher value.</li> <li>Opening the MyoHand VariPlus Speed with unwanted electrode signals is prevented.</li> <li>• Speed: proportional</li> <li>• Adjustment regulator A</li> </ul>	<ul style="list-style-type: none"> <li>• For patients with two strong electrode signals</li> </ul>
Programme 2	Open	Close	Indication
AutoControl LowInput	<ul style="list-style-type: none"> <li>• Sustained electrode signal</li> <li>• Reduced proportionality range: maximum speed once low threshold has been reached</li> <li>• Speed: proportional</li> <li>• Adjustment regulator A</li> </ul>	<ul style="list-style-type: none"> <li>• Sustained electrode signal</li> <li>• Gripping force: time proportional. After gripping once with maximum force, the EMG signal required to open the hand will be set to a higher value. Opening the MyoHand VariPlus Speed with unwanted electrode signals is prevented.</li> <li>• Speed: constant</li> <li>• Adjustment regulator B</li> </ul>	<ul style="list-style-type: none"> <li>• For patients with two weak electrode signals</li> </ul>
AutoControl LowInput	<ul style="list-style-type: none"> <li>• Sustained electrode signal</li> <li>• Reduced proportionality range: maximum speed once low threshold has been reached</li> <li>• Speed: proportional</li> <li>• Adjustment regulator A</li> </ul>	<ul style="list-style-type: none"> <li>• Signal via the switch</li> <li>• Gripping force: time proportional. After gripping once with maximum force, the EMG signal required to open the hand will be set to a higher value. Opening the MyoHand VariPlus Speed with unwanted electrode signals is prevented.</li> <li>• Speed: constant</li> <li>• Adjustment regulator B</li> </ul>	<ul style="list-style-type: none"> <li>• For patients with only one muscle and weak electrode signal</li> </ul>
AutoControl LowInput	<ul style="list-style-type: none"> <li>• The MyoHand VariPlus Speed opens as long as the OPEN side of the switch is operated</li> <li>• Speed: constant</li> <li>• Adjustment regulator A</li> </ul>	<ul style="list-style-type: none"> <li>• The MyoHand VariPlus Speed closes as long as the CLOSE side of the switch is operated</li> <li>• Gripping force: time proportional</li> <li>• Speed: constant</li> <li>• Adjustment regulator B</li> </ul>	<ul style="list-style-type: none"> <li>• For patients with a weak or no electrode signal</li> </ul>
Programme 3	Open	Close	Indication
VarioControl	<ul style="list-style-type: none"> <li>• Increasing electrode signal through muscle contraction</li> <li>• Speed and strength of muscle contraction on the electrode</li> <li>• Speed: proportional</li> <li>• Adjustment regulator A</li> </ul>	<ul style="list-style-type: none"> <li>• Declining electrode signal through muscle relaxation</li> <li>• Gripping force: proportional to the decline of the electrode signal</li> <li>• Speed: proportional</li> <li>• Adjustment regulator A</li> </ul>	<ul style="list-style-type: none"> <li>• For patients with one strong electrode signal or tendency to co-contraction</li> </ul>
VarioControl	<ul style="list-style-type: none"> <li>• Speed and strength of pull on the linear control element</li> <li>• Speed: proportional</li> <li>• Adjustment regulator A</li> </ul>	<ul style="list-style-type: none"> <li>• Speed of release of pull on the linear control element.</li> <li>• Gripping force: proportional to the release of the pull on the linear control element</li> <li>• Speed: proportional</li> <li>• Adjustment regulator A</li> </ul>	<ul style="list-style-type: none"> <li>• For patients with a weak or no electrode signal</li> </ul>

# ▶ MyoHand VariPlus Speed

Programme 4	Open	Close	Indication
VarioDual	<ul style="list-style-type: none"> <li>Increasing electrode signal through muscle contraction on the first electrode</li> <li>Speed and strength of muscle contraction on the electrode</li> <li>Speed: proportional to the increase of the electrode signal</li> <li>Adjustment regulator A</li> </ul>	<ul style="list-style-type: none"> <li>Declining electrode signal through muscle relaxation on the first electrode</li> <li>Gripping force: proportional to the signal strength on the second electrode. If only the first electrode is used, the MyoHand VariPlus Speed closes up to the minimal gripping force.</li> <li>Increased gripping force: achieved by secondary gripping with a stronger electrode signal on the second electrode. After gripping once with maximum force, the EMG signal required to open the hand will be set to a higher value. Opening the MyoHand VariPlus Speed with unwanted electrode signals is prevented.</li> <li>Speed: proportional to the decline of the electrode signal on the first electrode / proportional to the signal strength on the second electrode.</li> <li>Adjustment regulator A</li> </ul>	<ul style="list-style-type: none"> <li>For patients with two strong electrode signals</li> </ul>
Programme 5	Open	Close	Indication
Digital Control	<ul style="list-style-type: none"> <li>Sustained electrode signal</li> <li>Adjustment regulator B</li> </ul>	<ul style="list-style-type: none"> <li>Sustained electrode signal</li> <li>Gripping force: duration of the signal</li> <li>Adjustment regulator B</li> </ul>	<ul style="list-style-type: none"> <li>For patients with two weak electrode signals</li> </ul>
Digital Control	<ul style="list-style-type: none"> <li>Sustained electrode signal</li> <li>Adjustment regulator B</li> </ul>	<ul style="list-style-type: none"> <li>Signal via the switch</li> <li>Gripping force: duration of the signal</li> <li>Adjustment regulator B</li> </ul>	<ul style="list-style-type: none"> <li>For patients with only one muscle and weak electrode signals</li> </ul>
Digital Control	<ul style="list-style-type: none"> <li>The MyoHand VariPlus Speed opens as long as the OPEN side of the switch is operated</li> <li>Adjustment regulator B</li> </ul>	<ul style="list-style-type: none"> <li>The MyoHand VariPlus Speed closes as long as the CLOSE side of the switch is operated</li> <li>Gripping force: duration of the signal</li> <li>Adjustment regulator B</li> </ul>	<ul style="list-style-type: none"> <li>For patients with weak or no electrode signals</li> </ul>
Programme 6	Open	Close	Indication
Double Channel Control	<ul style="list-style-type: none"> <li>Quick, strong electrode signal that reaches the upper threshold within 80 ms and is maintained above the upper threshold for at least 30 ms</li> <li>Adjustment regulator B</li> </ul>	<ul style="list-style-type: none"> <li>Slow, gentle electrode signal that does not reach the upper threshold within 80 ms</li> <li>Gripping force: duration of the signal</li> <li>Adjustment regulator B</li> </ul>	<ul style="list-style-type: none"> <li>For patients with one strong electrode signal</li> </ul>

# ▶ SensorHand Speed



646D165  
646D321=D

647H495

## SensorHand Speed

Art. no. 8E38=8

The SensorHand Speed with quick-disconnect wrist unit is suitable for all residual limb lengths, except wrist disarticulation residual limbs. Passive hand rotation with ratchet lock (can be replaced by the friction ring (article no. 11S30)). The SensorHand Speed features the automatic SUVA Sensor grip stabilisation system, the FlexiGrip function as well as different control modes for prostheses with one or two electrodes.

Coding plugs of various colours (article no. 13E184=\*) or the MyoSelect (article no. 757T13) are used to select the desired control mode. Please also note the information in the user manual regarding this.

- White: DMC plus control (article no. 13E184=1)
- Red: AutoControl LowInput control (article no. 13E184=2)
- Green: AutoControl control (article no. 13E184=3)
- Blue: VarioControl control (article no. 13E184=4)
- Yellow: VarioDual control (article no. 13E184=5)
- Purple: DMC plus control; SUVA sensors and FlexiGrip can be turned off (article no. 13E184=6)

The SensorHand Speed can be operated with the MyoEnergy Integral (article no. 757B35=\*), or the EnergyPack (article no. 757B20/757B21). With central coaxial plug connection, automatic shut-off electronics with integrated on-off switch, low-friction bevel gear, positive back lock and system inner hand. An integrated slip clutch makes opening possible in case of emergency.

Art. no.	Side	Size	Inner hand	User
8E38=8-L7¼	Left (L)	7¼	8X18=L7¼	Women, adolescents
8E38=8-L7¾	Left (L)	7¾	8X18=L7¾	Men
8E38=8-L8¼	Left (L)	8¼	8X18=L8¼	Men
8E38=8-R7¼	Right (R)	7¼	8X18=R7¼	Women, adolescents
8E38=8-R7¾	Right (R)	7¾	8X18=R7¾	Men
8E38=8-R8¼	Right (R)	8¼	8X18=R8¼	Men

### Technical data

Operating voltage	6 / 7.2 V
Opening width	100 mm
Proportional gripping force approx.	0–100 N
Proportional speed	15–300 mm/sec
Weight approx. (size 7¾)	473 g

- The electrodes must be adjusted with the MyoBoy (article no. 757M11)!
- For compatible prosthetic gloves, see pages 56–60.

# ▶ SensorHand Speed

## SensorHand Speed

Art. no. 8E39=8

The SensorHand Speed with lamination ring is suitable for wrist disarticulation residual limbs. Passive wrist rotation with friction. The SensorHand Speed features the automatic SUVA Sensor grip stabilisation system, the FlexiGrip function as well as different control modes for prostheses with one or two electrodes. Coding plugs of various colours (article no. 13E184=\*) or the MyoSelect (article no. 757T13) are used to select the desired control mode. Please also note the information in the user manual regarding this.

- White: DMC plus control (article no. 13E184=1)
- Red: AutoControl LowInput control (article no. 13E184=2)
- Green: AutoControl control (article no. 13E184=3)
- Blue: VarioControl control (article no. 13E184=4)
- Yellow: VarioDual control (article no. 13E184=5)
- Purple: DMC plus control; SUVA sensors and FlexiGrip can be turned off (article no. 13E184=6)

The SensorHand Speed can be operated with the MyoEnergy Integral (article no. 757B35=\*) or the EnergyPack (article no. 757B20/757B21). It features a centrally guided flat cable, automatic shut-off electronics with integrated on-off switch, low-friction bevel gear, positive back lock and system inner hand. An integrated slip clutch makes opening possible in case of emergency.



646D165  
646D321=D

647H495

Art. no.	Side	Size	Inner hand	User
8E39=8-L7¼	Left (L)	7¼	8X18=L7¼	Women, adolescents
8E39=8-L7¾	Left (L)	7¾	8X18=L7¾	Men
8E39=8-L8¼	Left (L)	8¼	8X18=L8¼	Men
8E39=8-R7¼	Right (R)	7¼	8X18=R7¼	Women, adolescents
8E39=8-R7¾	Right (R)	7¾	8X18=R7¾	Men
8E39=8-R8¼	Right (R)	8¼	8X18=R8¼	Men

### Technical data

Operating voltage	6 / 7.2 V
Opening width	100 mm
Proportional gripping force approx.	0–100 N
Proportional speed	15–300 mm / sec
Weight approx. (size 7¾)	446 g

- ⦿ The electrodes must be adjusted with the MyoBoy (article no. 757M11)!
- ⦿ For compatible prosthetic gloves, see pages 56–60.

# ▶ SensorHand Speed

Programme 1	Open	Close	Indication
DMC plus sensors • White coding plug • Two electrodes	• Myosignal via the electrode • Speed: proportional	• Myosignal via the electrode • Speed: proportional	• Preferred programme for patients with two strong muscle signals
<b>Programme 2</b>	<b>Open</b>	<b>Close</b>	<b>Indication</b>
AutoControl LowInput • Red coding plug • Two electrodes	• Myosignal via the electrode • Speed: proportional	• Myosignal to the electrode, digital (short signal at any level) • Speed: constant	• For patients with two weak muscle signals
AutoControl LowInput • Red coding plug • One electrode and any MyoBock switch	• Myosignal via the electrode • Speed: proportional	• Signal via the switch • Speed: constant	• For patients with only one muscle and weak muscle signal
AutoControl LowInput • Red coding plug • Any MyoBock switch	• Hand opens as long as the OPEN side of the switch is operated. • Speed: constant	• Signal via the CLOSE side of the switch: hand stops in an opened position • Speed: constant	• For patients with weak or no muscle signals
<b>Programme 3</b>	<b>Open</b>	<b>Close</b>	<b>Indication</b>
AutoControl • Green coding plug • One electrode	• Quick, sustained myosignal via the electrode • Speed: constant	• Very slow muscle relaxation via the electrode: hand stops in an opened position • Quick muscle relaxation via the electrode: hand closes • Speed: constant	• For patients with only one muscle and very weak muscle signal
AutoControl • Green coding plug • Any MyoBock switch	• Opens as long as the OPEN side of the switch is operated • Speed: constant	• Closes automatically as soon as the switch is released • Speed: constant	• For patients with weak or no muscle signals
<b>Programme 4</b>	<b>Open</b>	<b>Close</b>	<b>Indication</b>
VarioControl • Blue coding plug • One linear control element	• Speed and strength of muscle contraction on the electrode • Speed: proportional	• Speed and level of muscle relaxation on the electrode • Speed: proportional	• For patients with one muscle and strong muscle signal or tendency to co-contraction
VarioControl • Blue coding plug • One linear control element	• Speed and strength of pull on the linear control element • Speed: proportional	• Speed of the release of the pull of the linear control element • Speed: proportional	• For patients with weak or no muscle signal
<b>Programme 5</b>	<b>Open</b>	<b>Close</b>	<b>Indication</b>
VarioDual • Yellow coding plug • Two electrodes	• Speed and level of muscle contraction on the first electrode • Speed: proportional	• Speed and level of muscle relaxation on the first electrode • Speed: proportional • Gripping force proportional to strength of muscle signal on the second electrode	• Control for patients with two strong muscle signals
DMC plus (sensor system can be deactivated) • Purple coding plug • Two electrodes	• Myosignal via the electrode • Speed: proportional	• Myosignal via the electrode • Speed: proportional	• Programme for patients with two strong muscle signals • SUVA sensors and FlexiGrip can be switched off



# ▶ System Electric Hands and accessories

## DMC plus System Electric Hand

Art. no. 8E38=6

The DMC plus System Electric Hand with quick-disconnect wrist unit is suitable for all residual limb lengths, except wrist disarticulation residual limbs. Passive hand rotation with ratchet lock (can be replaced by the friction ring (article no. 11S30)). DMC plus control features a DMC and DMC plus control mode. The desired control option is selected with the integrated function plug (article no. 13E185). In DMC plus control mode, a higher signal is required to open the hand after grasping once with maximum gripping force. This reduces the risk of opening the hand with unintended muscle signals. Two independent measurement and control systems proportionally control both the gripping speed and gripping force. The gripping speed and gripping force are determined by the strength of the muscle signal. The DMC plus System Electric Hand can be operated with the MyoEnergy Integral (article no. 757B35=\*) or the Energy-Pack (article no. 757B20/757B21). It features a central coaxial plug connection, automatic shut-off electronics with integrated on-off switch, low-friction bevel gear, positive back lock and system inner hand. An integrated slip clutch makes opening possible in case of emergency.

Art. no.	Side	Size	Inner hand	User
8E38=6-L7	Left (L)	7	8X18=L7	Women, adolescents
8E38=6-R7	Right (R)	7	8X18=R7	Women, adolescents

### Technical data

Operating voltage	6/7.2 V
Opening width	79 mm
Proportional gripping force	0–90 N
Proportional speed	15–130 mm/sec
Weight (incl. system inner hand)	355 g

- The electrodes must be adjusted with the MyoBoy (article no. 757M11)!
- For compatible prosthetic gloves, see pages 56–60.



646D44

647H326



### Tip

- The Electric Hand size 7 closes the gap between the Electric Hand 2000 hand system for children and the well-known System Electric Hands for adults. It is particularly suitable for the fitting of adolescents or women with small, dainty hands.
- The System Electric Hands can be operated with Ottobock's Li-poly/Li-ion battery technology, the MyoEnergy Integral and Energy-Pack.

## ► System Electric Hands and accessories



646D44

647H326

### DMC plus System Electric Hand

Art. no. 8E39=6

The DMC plus System Electric Hand with lamination ring is suitable for wrist disarticulation residual limbs. Passive wrist rotation with friction. DMC plus control features a DMC and DMC plus control mode. The desired control option is selected with the integrated function plug (article no. 13E185). In DMC plus control mode, a higher signal is required to open the hand after grasping once with maximum gripping force. This reduces the risk of opening the hand with unintended muscle signals. Two independent measurement and control systems proportionally control both the gripping speed and gripping force. The gripping speed and gripping force are determined by the strength of the muscle signal. The DMC plus System Electric Hand can be operated with the MyoEnergy Integral (article no. 757B35=\*) or the EnergyPack (article no. 757B20/757B21). It features a centrally guided flat cable, automatic shut-off electronics with integrated on-off switch, low-friction bevel gear, positive back lock and system inner hand. An integrated slip clutch makes opening possible in case of emergency.

Art. no.	Side	Size	Inner hand	User
8E39=6-L7	Left (L)	7	8X18=L7	Women, adolescents
8E39=6-R7	Right (R)	7	8X18=R7	Women, adolescents



#### Tip

- The Electric Hand size 7 closes the gap between the Electric Hand 2000 hand system for children and the well-known System Electric Hands for adults. It is particularly suitable for the fitting of adolescents or women with small, dainty hands.
- The System Electric Hands can be operated with Ottobock's Li-poly/ Li-ion battery technology, the EnergyPack.

#### Technical data

Static current	1 mA
Operating voltage	6 / 7.2 V
Opening width	79 mm
Proportional gripping force	0–90 N
Proportional speed	15–130 mm/sec
Weight (incl. system inner hand)	355 g

- The electrodes must be adjusted with the MyoBoy (article no. 757M11)!
- For compatible prosthetic gloves, see pages 56–60.

## ▶ System Electric Hands and accessories

### Transcarpal Hand DMC plus

Art. no. 8E44=6

Its lamination plate makes it suitable for residual limb lengths from wrist disarticulation to transcarpal levels. Without hand rotation, i.e. active pronation and supination are essential (fine adjustment of the basic position is possible, however, after the socket has been completed). DMC plus control features a DMC and DMC plus control mode. In DMC plus control mode, a higher signal is required to open the hand after grasping once with maximum gripping force. This reduces the risk of opening the hand with unintended muscle signals. The desired control option is selected with the integrated function plug (article no. 13E185). In the DMC plus system, two independent measurement and control systems proportionally control the speed as well as the gripping force. The DMC plus Transcarpal Hand can be operated with the MyoEnergy Integral (article no. 757B35=\*) or the EnergyPack (article no. 757B20/757B21). It features a centrally guided flat cable, automatic shut-off electronics with integrated on-off switch, low-friction bevel gear, positive back lock and system inner hand. An integrated slip clutch makes opening possible in case of emergency.

Art. no.	Side	Size	Inner hand	User
8E44=6-L7¼	Left (L)	7¼	8X24=L7¼	Women, adolescents
8E44=6-L7¾	Left (L)	7¾	8X24=L7¾	Men
8E44=6-L8¼	Left (L)	8¼	8X24=L8¼	Men
8E44=6-R7¼	Right (R)	7¼	8X24=R7¼	Women, adolescents, men
8E44=6-R7¾	Right (R)	7¾	8X24=R7¾	Men
8E44=6-R8¼	Right (R)	8¼	8X24=R8¼	Men

#### Technical data

Operating voltage	6 / 7.2 V
Operating temperature	0 to +70°C
Opening width	100 mm
Proportional gripping force	0–90 N
Proportional speed	15–160 mm/sec
Weight (incl. system inner hand)	308 g

- ▶ The electrodes must be adjusted with the MyoBoy (article no. 757M11)!
- ▶ For compatible prosthetic gloves, see pages 56–60.



646D44

647H398

## ▶ Myo terminal device



646D44



### Tip

- The Electric Hand size 7 closes the gap between the Electric Hand 2000 hand system for children and the well-known system electric hands for adults. It is particularly suitable for the fitting of adolescents or women with small, dainty hands.
- It is offered with the familiar Digital Twin and DMC plus control systems.
- The system electric hands can be operated with the EnergyPack, Ottobock's Li-ion battery technology.

## Digital Twin system electric hand

Article no. 8E38=7

The Digital Twin system electric hand with quick-disconnect wrist unit is suitable for all residual limb lengths, except wrist disarticulation residual limbs. Passive hand rotation with ratchet lock (can be replaced by the friction ring (article no. 11S30)). The Digital Twin control device features a digital and dual-channel control mode. The desired control option is selected with the integrated function plug (article no. 13E185). The Digital Twin system electric hand can be operated with the MyoEnergy Integral (article no. 757B35=\*) , the EnergyPack (article no. 757B20/757B21) or the X-ChangePack (article no. 757B15).

It features a central coaxial plug connection, automatic shut-off electronics with integrated on-off switch, low-friction bevel gear, positive back lock and system inner hand. With potentiometer for adjusting the switching threshold (double-channel control). An integrated slip clutch makes opening possible in case of emergency.

Article no.	Side	Size	Inner hand	User
8E38=7-L7	Left (L)	7	8X18=L7	Women, adolescents
8E38=7-L7 ¼	Left (L)	7 ¼	8X18=L7 ¼	Women, adolescents, men
8E38=7-L7 ¾	Left (L)	7 ¾	8X18=L7 ¾	Women, adolescents, men
8E38=7-L8 ¼	Left (L)	8 ¼	8X18=L8 ¼	Women, adolescents, men
8E38=7-R7	Right (R)	7	8X18=R7	Women, adolescents
8E38=7-R7 ¼	Right (R)	7 ¼	8X18=R7 ¼	Women, adolescents, men
8E38=7-R7 ¾	Right (R)	7 ¾	8X18=R7 ¾	Women, adolescents, men
8E38=7-R8 ¼	Right (R)	8 ¼	8X18=R8 ¼	Women, adolescents, men

### Technical data

Operating voltage	6 / 7.2 V
Max. opening width	79 mm (size 7), 100 mm (size 7 ¼, 7 ¾, 8 ¼)
Max. gripping force	90 N
Maximum speed	110 mm / sec
Weight (incl. system inner hand)	355–457 g

- The electrodes must be adjusted with the MyoBoy (article no. 757M11)!
- For compatible prosthetic gloves, see pages 62–65.

## ▶ Myo terminal device

### Digital Twin system electric hand

Article no. 8E39=7

The Digital Twin system electric hand with lamination ring is suitable for wrist disarticulation residual limbs. Passive wrist rotation with friction. The Digital Twin control device features a digital and dual-channel control mode. The desired control option is selected with the integrated function plug (article no. 13E185). The Digital Twin system electric hand can be operated with the MyoEnergy Integral (article no. 757B35=\*), the EnergyPack (article no. 757B20/757B21) or the X-ChangePack (article no. 757B15). It features a centrally guided flat cable, automatic shut-off electronics with integrated on-off switch, low-friction bevel gear, positive back lock and system inner hand. With potentiometer for adjusting the switching threshold (double-channel control). An integrated slip clutch makes opening possible in case of emergency.

Article no.	Side	Size	Inner hand	User
8E39=7-L7	Left (L)	7	8X18=L7	Women, adolescents
8E39=7-L7 ¼	Left (L)	7 ¼	8X18=L7 ¼	Women, adolescents, men
8E39=7-L7 ¾	Left (L)	7 ¾	8X18=L7 ¾	Women, adolescents, men
8E39=7-L8 ¼	Left (L)	8 ¼	8X18=L8 ¼	Women, adolescents, men
8E39=7-R7	Right (R)	7	8X18=R7	Women, adolescents
8E39=7-R7 ¼	Right (R)	7 ¼	8X18=R7 ¼	Women, adolescents, men
8E39=7-R7 ¾	Right (R)	7 ¾	8X18=R7 ¾	Women, adolescents, men
8E39=7-R8 ¼	Right (R)	8 ¼	8X18=R8 ¼	Women, adolescents, men

#### Technical data

Operating voltage	6/7.2 V
Max. opening width	79 mm (size 7), 100 mm (size 7 ¼, 7 ¾, 8 ¼)
Max. gripping force	90 N
Maximum speed	110 mm/sec
Weight (incl. system inner hand)	355–457 g

- The electrodes must be adjusted with the MyoBoy (article no. 757M11)!
- For compatible prosthetic gloves, see pages 62–65.



646D44

647H327



#### Tip

- The Electric Hand size 7 closes the gap between the Electric Hand 2000 hand system for children and the well-known system electric hands for adults. It is particularly suitable for the fitting of adolescents or women with small, dainty hands.
- It is offered with the familiar Digital Twin and DMC plus control systems.
- The system electric hands can be operated with the EnergyPack, Ottobock's Li-ion battery technology.



## ▶ Myo terminal device



646D44

647H327

### Digital Twin system electric hand

Article no. 8E41=7

The Digital Twin system electric hand with M12X1.5 threaded stud is suitable for all residual limb lengths, except wrist disarticulation residual limbs. The Digital Twin control device features a digital and dual-channel control mode. The desired control option is selected with the integrated function plug (article no. 13E185). The Digital Twin system electric hand can be operated with the MyoEnergy Integral (article no. 757B35=\*), the EnergyPack (article no. 757B20/757B21) or the X-ChangePack (article no. 757B15). It features a central cable outlet, automatic shut-off electronics with integrated on-off switch, low-friction bevel gear, positive back lock and system inner hand. With potentiometer for adjusting the switching threshold (double-channel control). An integrated slip clutch makes opening possible in case of emergency.

Article no.	Side	Size	Inner hand	User
8E38=7-L7	Left (L)	7	8X18=L7	Women, adolescents
8E38=7-L7 ¼	Left (L)	7 ¼	8X18=L7 ¼	Women, adolescents, men
8E38=7-L7 ¾	Left (L)	7 ¾	8X18=L7 ¾	Women, adolescents, men
8E38=7-L8 ¼	Left (L)	8 ¼	8X18=L8 ¼	Women, adolescents, men
8E38=7-R7	Right (R)	7	8X18=R7	Women, adolescents
8E38=7-R7 ¼	Right (R)	7 ¼	8X18=R7 ¼	Women, adolescents, men
8E38=7-R7 ¾	Right (R)	7 ¾	8X18=R7 ¾	Women, adolescents, men
8E38=7-R8 ¼	Right (R)	8 ¼	8X18=R8 ¼	Women, adolescents, men

#### Technical data

Operating voltage	6 / 7.2 V
Max. opening width	79 mm (size 7), 100 mm (size 7 ¼, 7 ¾, 8 ¼)
Max. gripping force	90 N
Maximum speed	110 mm / sec
Weight (incl. system inner hand)	355–457 g

- The electrodes must be adjusted with the MyoBoy (article no. 757M11)!
- For compatible prosthetic gloves, see pages 62–65.



#### Tip

- The Electric Hand size 7 closes the gap between the Electric Hand 2000 hand system for children and the well-known system electric hands for adults. It is particularly suitable for the fitting of adolescents or women with small, dainty hands.
- It is offered with the familiar Digital Twin and DMC plus control systems.
- The system electric hands can be operated with the EnergyPack, Ottobock's Li-ion battery technology.

## ▶ System Electric Hands and accessories



### System inner hand

Art. no. 8X18

System inner hand for Ottobock System Electric Hands sizes 7, 7¼, 7¾ and 8¼. Energy-saving, lightweight plastic version with partial reinforcement, with wire inserts in the fingers and sealing retainer ring or lock ring.

Art. no.	Side	Size	Retainer ring or lock ring
8X18=L7	Left (L)	7	9S15=48
8X18=L7¼	Left (L)	7¼	9S187=7¼
8X18=L7¾	Left (L)	7¾	9S187=7¾
8X18=L8¼	Left (L)	8¼	9S187=8¼
8X18=R7	Right (R)	7	9S15=48
8X18=R7¼	Right (R)	7¼	9S187=7¼
8X18=R7¾	Right (R)	7¾	9S187=7¾
8X18=R8¼	Right (R)	8¼	9S187=8¼



### System inner hand

Art. no. 8X24

The system inner hand for Ottobock Transcarpal Hands sizes 7¼, 7¾ and 8¼.

Art. no.	Side	Size
8X24=L7¼	Left (L)	7¼
8X24=L7¾	Left (L)	7¾
8X24=L8¼	Left (L)	8¼
8X24=R7¼	Right (R)	7¼
8X24=R7¾	Right (R)	7¾
8X24=R8¼	Right (R)	8¼

## ▶ System Electric Hands and accessories



### Lock ring

Art. no. 9S187

Compatible with hand sizes 7¼, 7¾ and 8¼.

Art. no.	Size
9S187=7¼	7¼
9S187=7¾	7¾
9S187=8¼	8¼

◻ Notice: The lock ring for the endoskeletal adapter and MyoWrist Transcarpal has the reference number 9S267=\*



### Special thread

Art. no. 624Z12

The special thread is used for sealing the system inner hand (article no. 8X24) of the Transcarpal Hand.



### Cable seal

Art. no. 9E388

Cable seal for hand cable (article no. 9E53) with the Transcarpal Hand.



### Hexagon nut

Art. no. 502S97=M5

Hexagon nut with flange for the Transcarpal Hand.

# ▶ System Electric Hands and accessories

## Tweezers

Art. no. 8Y1



## Pinch gauge

Art. no. 743F1

The pinch gauge is used to check the gripping force of System Electric Hands.



## Derma Protection ArmComfort

Art. no. 453A1

Derma Protection ArmComfort makes the transition from the forearm socket to the upper arm more visually appealing and provides additional support for the prosthesis. The special polymer gel coating, high elasticity and anatomical fit also improve wearer comfort. Suitable for children (article no. 453A1=1) and adults (article no. 453A1).



## EasyFit Arm donning sheath

Art. no. OC1560

The EasyFit Arm donning sheath with valve opening (colour: green) saves strength and time when putting on an arm prosthesis. It feels comfortable when donning. It is made of high-quality material and is therefore very durable. It is also easy to clean in the washing machine. Also available in children's sizes.

Art. no.	Size	Proximal residual limb circumference	Distal residual limb circumference	Sock length
OC1560=KIDS	KIDS	290 mm	150 mm	210 mm
OC1560=TR	TR	420 mm	220 mm	250 mm
OC1560=TH	TH	470 mm	280 mm	340 mm



646D536=M\_DE

# ▶ Prosthetic gloves and accessories

## Natural: MyoSkin Natural

In addition to the standard prosthetic glove, Ottobock also offers additional models of the Skin Natural series. The multilayer structure of the gloves gives them a depth effect so that they have a very vivid appearance. The PVC-based material ensures that Skin Natural is very robust compared to other materials and it has a relatively long life. This provides safety when using the gloves.

Due to a special modern surface treatment, the Skin Natural gloves are also easy to clean. The outer translucent layer allows the coloured fibres of the material to shine through. This simulates the natural vein structure of human skin.

The entire Skin Natural colour palette is produced with seven colours. The new 646M47 colour scale helps when selecting the right pattern. For available colours, please ask our customer service.



646D423

647G571

## MyoSkin Natural

Art. no. 8S11N

The MyoSkin Natural (article no. 8S11N) is suitable for men.

Art. no.	Side	Size	Inner hand	Sleeve length	Sleeve end circumference
8S11N=190X76L	Left (L)	7¼	8X18=L7¼, 8X24=L7¼	300 mm	230 mm
8S11N=210X78L	Left (L)	7¾	8X18=L7¾, 8X24=L7¾	320 mm	250 mm
8S11N=225X80L	Left (L)	8¼	8X18=L8¼, 8X24=L8¼	350 mm	260 mm
8S11N=190X76R	Right (R)	7¼	8X18=R7¼, 8X24=R7¼	300 mm	230 mm
8S11N=210X78R	Right (R)	7¾	8X18=R7¾, 8X24=R7¾	320 mm	250 mm
8S11N=225X80R	Right (R)	8¼	8X18=R8¼, 8X24=R8¼	350 mm	260 mm

Notice: The 8S11N=\* gloves are available in seven colours 2, 4, 6, 8, 11, 14 and 16. The new 646M47 colour scale helps to find the right shade.

# ▶ Prosthetic gloves and accessories

## MyoSkin Natural

Art. no. 8S12N

The MyoSkin Natural (article no. 8S12N) is suitable for women.

Art. no.	Side	Size	Inner hand	Sleeve length	Sleeve end circumference
8S12N=190X78L	Left (L)	7¼	8X18=L7¼, 8X24=L7¼	460 mm	250 mm
8S12N=190X78R	Right (R)	7¼	8X18=R7¼, 8X24=R7¼	460 mm	250 mm

- Notice: The 8S12N=\* gloves are available in seven colours 2, 4, 6, 8, 11, 14 and 16. The new 646M47 colour scale helps to find the right shade.

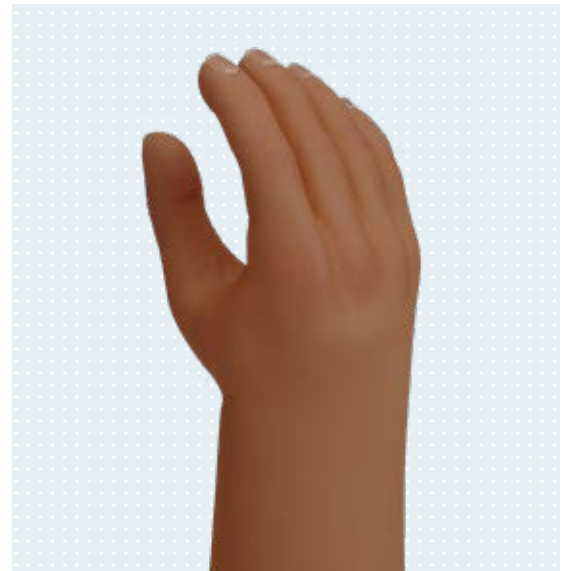

 646D423

 647G571

## MyoSkin Natural

Art. no. 8S13N

The MyoSkin Natural (article no. 8S13N) is suitable for adolescents and women.

Art. no.	Side	Size	Inner hand	Sleeve length	Sleeve end circumference
8S13N=7L	Left (L)	7	8X18=L7	280 mm	242 mm
8S13N=7R	Right (R)	7	8X18=R7	280 mm	242 mm

- Notice: The 8S13N=\* gloves are available in seven colours 2, 4, 6, 8, 11, 14 and 16. The new 646M47 colour scale helps to find the right shade.

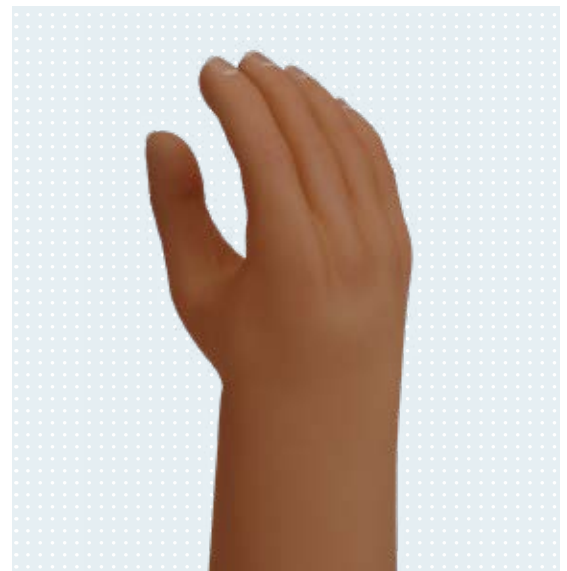

 646D423

 647G571

 Special cleaner for prosthetic gloves is found on page 60.



## ▶ Prosthetic gloves and accessories



646D49

647G468

### Prosthetic glove for adolescents and men

Art. no. 8S11

The Ottobock prosthetic glove for adolescents and men features an impressively natural appearance, durability and flexibility. Size 7¼ is suitable for adolescents and men, the three additional sizes for men.

Art. no.	Side	Size	Inner hand	Sleeve length	Sleeve end circumference
8S11=190X76L	Left (L)	7¼	8X18=L7¼, 8X24=L7¼	300 mm	230 mm
8S11=210X78L	Left (L)	7¾	8X18=L7¾, 8X24=L7¾	320 mm	250 mm
8S11=225X80L	Left (L)	8¼	8X18=L8¼, 8X24=L8¼	350 mm	260 mm
8S11=190X76R	Right (R)	7¼	8X18=R7¼, 8X24=R7¼	300 mm	230 mm
8S11=210X78R	Right (R)	7¾	8X18=R7¾, 8X24=R7¾	320 mm	250 mm
8S11=225X80R	Right (R)	8¼	8X18=R8¼, 8X24=R8¼	350 mm	260 mm

Available in 18 different shades. When ordering, please add the colour code according to the 646M3 colour sample set to the end of the article number e.g., 8S11=190X76L4

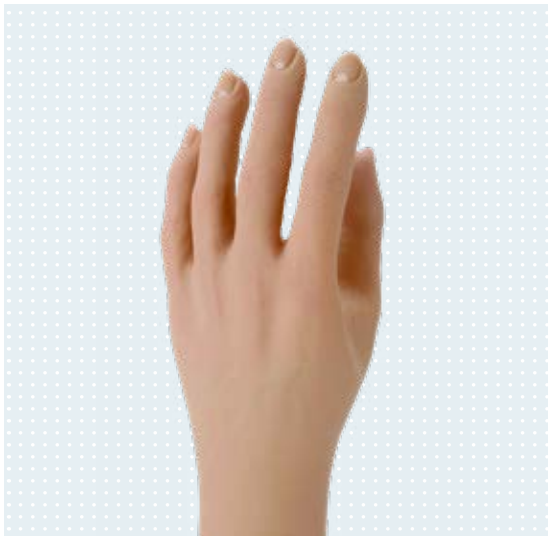

646D49

647G468

### Prosthetic glove for women

Art. no. 8S12

The prosthetic glove for women features an impressively natural appearance, durability and flexibility.

Art. no.	Side	Size	Inner hand	Sleeve length	Sleeve end circumference
8S12=190X78L	Left (L)	7¼	8X18=L7¼, 8X24=L7¼	460 mm	250 mm
8S12=190X78R	Right (R)	7¼	8X18=R7¼, 8X24=R7¼	460 mm	250 mm

Available in 18 different shades. When ordering, please add the colour code according to the 646M3 colour sample set to the end of the article number e.g., 8S12=190x78L4

## ▶ Prosthetic gloves and accessories

### Prosthetic glove for children and adolescents

Art. no. 8S13

The prosthetic glove for children and adolescents features an impressively natural appearance, durability and flexibility.

Art. no.	Side	Size	Inner hand	Sleeve length	Sleeve end circumference
8S13=7L	Left (L)	7	8X18=L7	280 mm	242 mm
8S13=7R	Right (R)	7	8X18=R7	280 mm	242 mm

- Available in 18 different shades. When ordering, please add the colour code according to the 646M3 colour sample set to the end of the article number e.g., 8S13=7L4



 646D49

 647G468

 Special cleaner for prosthetic gloves is found on page 60.

## ▶ Prosthetic gloves and accessories



### Special cleaner

Art. no. 640F12

In case of heavy soiling, the special cleaner for prosthetic gloves should be applied immediately (net contents: 460 g).



### Pump sprayer

Art. no. 640F13

The user should always keep a pump sprayer filled with special cleaner for Ottobock prosthetic gloves handy in order to be able to use the cleaner immediately in case of soiling (net contents: 90 g).

🔴 This container is empty on delivery!



### Donning spray

Art. no. 640F18

The donning spray for silicone liners and prosthetic gloves (silicone or PVC) is used among other things for the donning and removal of the liner or prosthetic glove.

Art. no.	Contents
640F18	90 ml
640F18=900	900 ml (refill)

## ▶ System Electric Greifer

### DMC VariPlus System Electric Greifer

Art. no. 8E33=9-1

The DMC VariPlus System Electric Greifer with quick-disconnect wrist unit is based on Ottobock's DMC system (DMC= dynamic mode control). This system developed by Ottobock uses two independent measurement and control systems in order to optimally control the gripping speed and gripping force in accordance with the patient's muscle signal. It is suitable for all residual limb lengths, except wrist disarticulation residual limbs. Six different programmes can be selected and adjusted using the MyoSelect (article no. 757T13). They allow the prosthesis to be optimally adapted to the user's individual abilities and requirements. The DMC VariPlus System Electric Greifer can be operated with the MyoEnergy Integral (article no. 757B35=\*), or the EnergyPack (article no. 757B20 or 757B21). With central coaxial plug connection, energy-saving, automatic shut-off electronics and on-off switch. Metal fingertips and grip surfaces covered with rubber for normal gripping functions.

#### Technical data

Operating voltage	6 / 7.2 V
Max. opening width	95 mm
Max. gripping force	0 – 160 N
Maximum speed	8 – 200 mm/sec
Weight	540 g

• The electrodes must be adjusted with the MyoBoy (article no. 757M11)!



647G278

### DMC VariPlus System Electric Greifer

Art. no. 8E34=9-1

The DMC VariPlus System Electric Greifer with lamination ring is based on Ottobock's DMC system (DMC= dynamic mode control): This system developed by Ottobock uses two independent measurement and control systems in order to optimally control the gripping speed and gripping force in accordance with the patient's muscle signal. Suitable for wrist disarticulation residual limbs. Six different programmes can be selected and adjusted using the MyoSelect (article no. 757T13). They allow the prosthesis to be optimally adapted to the user's individual abilities and requirements. The DMC VariPlus System Electric Greifer can be operated with the MyoEnergy Integral (article no. 757B35=\*), or the EnergyPack (article no. 757B20 or 757B21). With central flat cable connection, energy-saving, automatic shut-off electronics and on-off switch. Metal fingertips and grip surfaces covered with rubber for normal gripping functions.

#### Technical data

Operating voltage	6 / 7.2 V
Max. opening width	95 mm
Max. gripping force	0 – 160 N
Maximum speed	8 – 200 mm/sec
Weight	520 g

• The electrodes must be adjusted with the MyoBoy (article no. 757M11)!



647G278

## ▶ Wrist joints and accessories



647G351

### MyoWrist Transcarpal

Art. no. 10V38

The MyoWrist Transcarpal enables flexion and extension of a myoelectrically controlled Transcarpal Hand (article no. 8E44). Can be locked in five positions from  $-40^{\circ}$  to  $+40^{\circ}$ . Passive pronation and supination is possible thanks to the quick-disconnect wrist unit. In combination with the optional electric rotator (article no. 10S17), pronation and supination driven by an electric motor can be offered. Compatible with all 8E44=\* hands.

#### Consisting of

- Lock ring (article no. 9S267=\*)

Art. no.	Side	Size
10V38=L7¼	Left (L)	7¼
10V38=L7¾	Left (L)	7¾
10V38=L8¼	Left (L)	8¼
10V38=R7¼	Right (R)	7¼
10V38=R7¾	Right (R)	7¾
10V38=R8¼	Right (R)	8¼

#### Technical data

Exterior diameter	36 mm
Overall length	24.7 mm
Weight	85–89 g

- The MyoWrist Transcarpal can also be used with the endoskeletal adapter (article no. 8R1)!

**i** Please note the accessories on the following page!



647G459

### MyoWrist 2Act

Art. no. 10V40

The MyoWrist 2Act (article no. 10V40) was developed especially for all versions of the System Electric Hands with threaded stud (article no. 8E41) to maintain a low structural height for the overall system. Flexion and extension is possible with five locking positions from  $-40^{\circ}$  to  $+40^{\circ}$  in  $20^{\circ}$  increments. Rotation is performed passively via the quick-disconnect wrist unit. Active rotation is also possible in combination with the MyoRotronic (article no. 13E205).

#### Technical data

Exterior diameter	36 mm
Overall length	26 mm
Weight	55 g

## ▶ Wrist joints and accessories

### Chassis

Art. no. 9S266

Chassis with quick-disconnect wrist unit.



### Coaxial bushing

Art. no. 9E397

Art. no.	Control device	Wrist connection
9E397=7	Coaxial bushing (DMC plus)	8E44 with 10V38
9E397=10	VariPlus Speed control	8E41 with 10V40

• The scope of delivery for article no. 9E397=7 includes the cable connector, article no. 9E167!

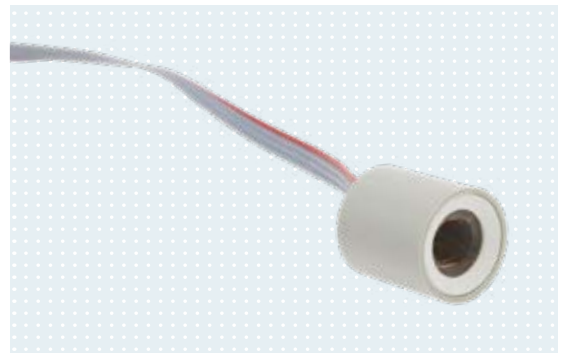

### Cable connector

Art. no. 9E167



### Lamination ring

Art. no. 10S1

Lamination ring for System Electric Hands (article no. 8E38) or System Electric Greifers (article no. 8E33) with lamination protection cover for bonding.

Art. no.	Size
10S1=40	7
10S1=45	7 and 7¼
10S1=50	7¼ and System Electric Greifer (article no. 8E33=*)
10S1=54	8¼





## ▶ Wrist joints and accessories

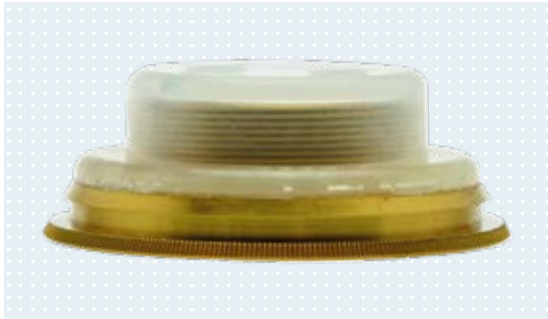

### Lamination ring

Art. no. 9S110

Lamination ring for laminating all System Electric Hands (article no. 8E39) or System Electric Greifers (article no. 8E34).

Art. no.	Size
9S110=50	7, 7¼, 7¾, System Electric Greifer (article no. 8E34=*)
9S110=54	8¼



### Lamination plate

Art. no. 9S258

Lamination plate for Transcarpal Hand (article no. 8E44).

Art. no.	Side	Size
9S258=L7¼	Left (L)	7¼
9S258=L7¾	Left (L)	7¾
9S258=L8¼	Left (L)	8¼
9S258=R7¼	Right (R)	7¼
9S258=R7¾	Right (R)	7¾
9S258=R8¼	Right (R)	8¼



### Coaxial plug

Art. no. 9E169

Coaxial plug for connecting the two electrodes and the battery.

#### Consisting of

- Coaxial plug piece
- Lock ring (article no. 9E170)
- Oval head screw (article no. 501S50=M4X6)



### Coupling piece

Art. no. 10S4

Coupling piece with lock ring.

## ▶ Wrist joints and accessories

### Electric rotator

Art. no. 10S17

Electric rotator for power-driven rotation of the System Electric Hand or System Electric Greifer.

#### Consisting of

- Lock ring (article no. 11S4)
- Joint drive with coaxial plug (article no. 11S61)
- Lock ring (article no. 11S25)
- Protective cap (article no. 9E85)
- Protective plug (article no. 9E365)

#### Technical data

Operating voltage	6 / 7.2 V
Approx. no-load current	150 mA
Approx. stall current	1,000 mA
Idle speed	13.5 RPM
Angle of rotation	360°
Corresponds to a rotation angle of	81° / sec.
Weight	96 g



647H204

### MyoRotronic

Art. no. 13E205

The MyoRotronic enables the proportional or digital control of the electric rotator (article no. 10S17). Compatible with all MyoBock System Electric Hands and System Electric Greifers with quick-disconnect wrist unit. Not suitable for use with System Electric Hands for other manufacturers' systems. Five different programmes can be selected using the MyoSelect (article no. 757T13) and allow individual adaptation to the respective patient. The MyoRotronic (article no. 13E205) is controlled by one or two electrodes (article no. 13E200) or suction socket electrodes (article no. 13E202) or a combination of one electrode and a linear control element (article no. 9X50/9X52). The scope of delivery includes a buzzer (article no. 13E183) for acoustic feedback on the switchover.

#### Power supply

- MyoEnergy Integral 7.4 V (article no. 757B35)
- EnergyPack 7.2 V (article no. 757B20 / 757B21)

#### Technical data

Static current	1 mA
Operating temperature	0 to +70°C
Power off	load dependent between 30 ms and 10 s

- The MyoSelect (article no. 757T13) is required for programme selection and adjustment of the MyoRotronic (article no. 13E205).
- When using the electric rotator (article no. 10S17) and the MyoRotronic (article no. 13E205), the distance between the residual limb end and wrist joint must be at least 65 mm.
- Rotation can be switched off (only in programme 1 of the 4-channel control) using the connection cable (article no. 9X24).



647G361

## ▶ Wrist joints and accessories

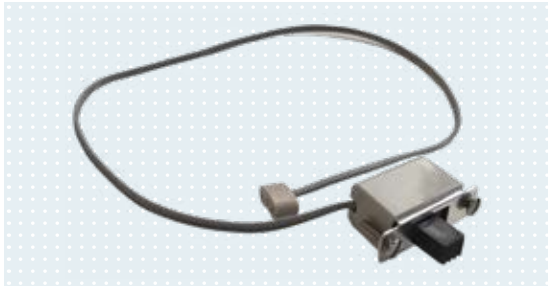

### Connection cable

Art. no. 9X24

Connection cable to deactivate rotation.

- **Notice:** Only possible in programme 1 of 4-channel control!
- The connection cable (article no. 9X13=4) is not included in the scope of delivery.
- Only required when the MyoRotronic is used.



### Endoskeletal adapter

Art. no. 8R1

Endoskeletal adapter for long and short residual limb prostheses in combination with the Transcarpal Hand (article no. 8E44; not included in the scope of delivery!). The endoskeletal adapter allows the use of the Transcarpal Hand as a particularly short and lightweight prosthetic hand with quick-disconnect mechanism for prostheses for both long and short residual limbs.

#### Particularly lightweight

Compared to a conventional System Electric Hand (article no. 8E38), the weight is reduced by approx. 80–100 g (approx. -20%), depending on size and tube length, without functional constraints. In addition, the proximal position of the quick-disconnect mechanism is beneficial to the prosthesis wearer.

#### Particularly short

The shortest version of the Transcarpal Hand with the quick-disconnect mechanism of the endoskeletal adapter is 145 mm, whereas the comparable System Electric Hand is 170 mm (= -15%). Size 7¾ with system inner hand was measured in each case.

#### Consisting of

- Coding ring, brown (1 pc.)
- Plate (article no. 9S263=R/L)
- Threaded connector (article no. 9S264)
- Threaded connector (article no. 9S265)
- Lock ring (article no. 9S267=\*)
- Cable connector (article no. 9E167)
- Cable seal (article no. 9E388)
- Chassis (article no. 9S266)
- Coaxial bushing (article no. 9E397=8)
- Cover plate brown for coaxial bushing
- UHU-plus, endfest 300 (article no. 636W23)

647H501

Art. no.	Side	To be used for the Transcarpal Hand
8R1=L7¼	Left (L)	8E44=6-L7¼
8R1=L7¾	Left (L)	8E44=6-L7¾
8R1=L8¼	Left (L)	8E44=6-L8¼
8R1=R7¼	Right (R)	8E44=6-R7¼
8R1=R7¾	Right (R)	8E44=6-R7¾
8R1=R8¼	Right (R)	8E44=6-R8¼

- The endoskeletal adapter (article no. 8R1) can also be combined with the wrist joints (article no. 10V38 and 10V40)!

# DynamicArm

## DynamicArm

Art. no. 12K100N

The DynamicArm with electric drive, continuously electronically controlled Vario-gear, integrated Li-Ion battery, Bluetooth® interface BionicLink, electronically controlled AFB flexion aid and upper arm rotation joint (humeral rotation feature) with adjustable friction, forearm length of max. 305 mm and an external 9X13=4 switch. The DynamicArm is a microprocessor-controlled elbow joint driven by an electric motor that can be controlled by the user with great precision. The elbow flexion and extension speed can be controlled proportionately. Likewise, pronation and supination of the wrist joint can be controlled proportionately via the integrated electronics of the electric rotator (article no. 10S17) (optional).

Up to 6 kg can be actively lifted depending on the forearm length.

When the user is active at a normal level, the integrated Li-ion battery with a capacity of 1,800 mAh will last approximately one day.

The BionicLink Bluetooth interface is integrated into the DynamicArm.

In combination with the ElbowSoft software (article no. 646C42) and Bluetooth adapter (article no. 60X5), it supports wireless adjustments using a PC. In this way the prosthesis solution can be optimised even while the patient is wearing the prosthesis. Nine different programmes allow the system to adapt to various requirements. Moreover, all essential parameters can be set individually.

Art. no.	Size	Upper arm connection diameter	Lamination ring diameter	Colour
12K100N=45	7-7¼	70 mm	45 mm	4
12K100N=45-7	7-7¼	70 mm	45 mm	Black
12K100N=50	7¼-8¼	70 mm	50 mm	4
12K100N=50-1	7¼-8¼	70 mm	50 mm	11
12K100N=50-2	7¼-8¼	70 mm	50 mm	15
12K100N=50-7	7¼-8¼	70 mm	50 mm	Black
13Z157=45	Carbon shell			Black
13Z157=50	Carbon shell			Black
642C42=*	ElbowSoft			

- The colours roughly correspond to the glove colours according to the 646M3 colour sample set.
- This product requires certification. For further information, please contact our employees in customer service!

## Analogue adapter

Art. no. 13E100

The adapter enables the control of the analogue Ottobock hand systems in combination with the DynamicArm. The digital signal of the DynamicArm is converted to an analogue signal by the adapter.



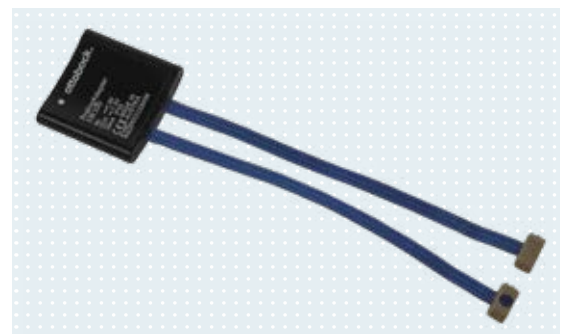

646D229  
646D120  
646D626=DE  
646D26=DE

647G152





 646D229  
646D120

 647G152

## DynamicArm Plus

Art. no. 12K110N

Like the DynamicArm, the DynamicArm Plus (article no. 12K110N) is a myoelectrically controlled elbow joint driven by an electric motor. It is intended for fitting users with transhumeral or higher amputation levels who are using TMR, or are able to use more than two signals to control their prosthesis. Targeted muscle reinnervation (TMR) is the medical term for the surgical rerouting of nerves. The innovative prosthetic fitting enables more natural motion sequences for the user because the active joints can be controlled simultaneously. The user acts with their so-called phantom limb, which can be moved instinctively in their remembered perception of their body. Learning to control the prosthesis has to be accompanied by intensive therapy. Apart from the advantages that control with more than two signals has to offer, it has the same features as the DynamicArm. Up to eight input signals can be processed in addition.

**The DynamicArm Plus can be combined with other myoelectric prosthetic components from Ottobock, such as**

- Electric rotator (article no. 10S17)
- SensorHand Speed (article no. 8E38=8\*)
- MyoHand VariPlus Speed (article no. 8E38=9\*)
- DMC VariPlus System Electric Greifer (article no. 8E33=9-1)
- bebionic hand with EQD wrist (article no. 8E70=\*)

Other prosthetic components cannot be used. Settings for the DynamicArm Plus can be configured using the software (article no. 646C57), the integrated Bluetooth module and a PC.

Art. no.	Size	Upper arm connection diameter	Lamination ring diameter	Colour
12K110N=45	7 – 7¼	70 mm	45 mm	4
12K110N=50	7¾ – 8¼	70 mm	50 mm	4
12K110N=50-1	7¾ – 8¼	70 mm	50 mm	11
12K110N=50-2	7¾ – 8¼	70 mm	50 mm	15
12K110N=45-7	7 – 7¼	70 mm	45 mm	Black
12K110N=50-7	7¾ – 8¼	70 mm	50 mm	Black
13Z157=45	Carbon shell			Black
13Z157=50	Carbon shell			Black
646C57=*	ElbowSoft TMR			

- The colours roughly correspond to the glove colours according to the 646M3 colour sample set.
- This product requires certification. For further information, please contact our employees in customer service!

## ▶ DynamicArm

### Alignment tool for DynamicArm

Art. no. 743A27

Alignment and foaming aid allows the alignment of an interim prosthesis for functional training in the rehabilitation phase.

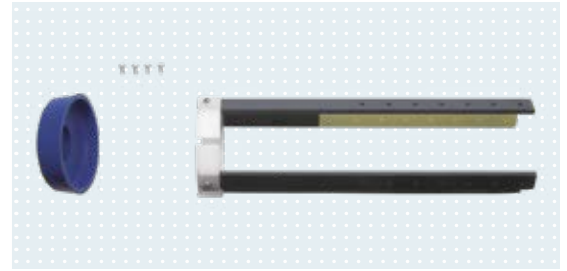



Programme	Activation	Switching version	DynamicArm flexion/extension	Electric rotator pronation/supination	System Electric Hand and Greifer	Indication
<b>1</b>	<ul style="list-style-type: none"> <li>• 2 electrodes</li> </ul>	<ul style="list-style-type: none"> <li>• Sequential switching with long or short co-contraction, with automatic switch-back to the hand</li> <li>• Vibration active</li> </ul>	<ul style="list-style-type: none"> <li>• Proportional</li> </ul>	<ul style="list-style-type: none"> <li>• Proportional</li> </ul>	<ul style="list-style-type: none"> <li>• All control versions for two strong muscle signals</li> </ul>	<ul style="list-style-type: none"> <li>• For patients with two strong muscle signals</li> </ul>
<b>2</b>	<ul style="list-style-type: none"> <li>• 2 electrodes</li> </ul>	<ul style="list-style-type: none"> <li>• Short co-contraction with automatic switch-back to the hand</li> <li>• Vibration active</li> </ul>	<ul style="list-style-type: none"> <li>• Proportional</li> </ul>	<ul style="list-style-type: none"> <li>• Not applicable</li> </ul>	<ul style="list-style-type: none"> <li>• All control versions for two strong muscle signals</li> </ul>	<ul style="list-style-type: none"> <li>• For patients with two strong muscle signals</li> </ul>
<b>3</b>	<ul style="list-style-type: none"> <li>• 2 electrodes and 1 switch</li> </ul>	<ul style="list-style-type: none"> <li>• Sequential switching with switch impulse</li> <li>• With automatic switch-back to the hand</li> <li>• Vibration active</li> </ul>	<ul style="list-style-type: none"> <li>• Proportional</li> </ul>	<ul style="list-style-type: none"> <li>• Proportional</li> </ul>	<ul style="list-style-type: none"> <li>• All control versions for two strong muscle signals</li> </ul>	<ul style="list-style-type: none"> <li>• For patients with two strong muscle signals</li> </ul>
	<ul style="list-style-type: none"> <li>• Two switches</li> </ul>	<ul style="list-style-type: none"> <li>• Sequential switching with switch impulse</li> <li>• With automatic switch-back to the hand</li> <li>• Vibration active</li> </ul>	<ul style="list-style-type: none"> <li>• Digital</li> </ul>	<ul style="list-style-type: none"> <li>• Digital</li> </ul>	<ul style="list-style-type: none"> <li>• All control versions for switch control</li> </ul>	<ul style="list-style-type: none"> <li>• For patients with weak or no muscle signals</li> </ul>
<b>4</b>	<ul style="list-style-type: none"> <li>• 2 electrodes and 1 switch</li> </ul>	<ul style="list-style-type: none"> <li>• Switching back and forth with switch impulse</li> <li>• With automatic switch-back to the hand</li> <li>• Vibration active</li> </ul>	<ul style="list-style-type: none"> <li>• Proportional</li> </ul>	<ul style="list-style-type: none"> <li>• Not applicable</li> </ul>	<ul style="list-style-type: none"> <li>• All control versions for two strong muscle signals</li> </ul>	<ul style="list-style-type: none"> <li>• For patients with two strong muscle signals</li> </ul>
	<ul style="list-style-type: none"> <li>• Two switches</li> </ul>	<ul style="list-style-type: none"> <li>• Switching back and forth with switch impulse</li> <li>• With automatic switch-back to the hand</li> <li>• Vibration active</li> </ul>	<ul style="list-style-type: none"> <li>• Digital</li> </ul>	<ul style="list-style-type: none"> <li>• Not applicable</li> </ul>	<ul style="list-style-type: none"> <li>• All control versions for switch control</li> </ul>	<ul style="list-style-type: none"> <li>• For patients with weak or no muscle signals</li> </ul>
<b>5</b>	<ul style="list-style-type: none"> <li>• 2 electrodes and one 4-stage control element</li> </ul>	<ul style="list-style-type: none"> <li>• Direct switching with the impulse of a 4-stage control element</li> <li>• With automatic switch-back to the hand</li> <li>• Vibration active</li> </ul>	<ul style="list-style-type: none"> <li>• Proportional</li> </ul>	<ul style="list-style-type: none"> <li>• Proportional</li> </ul>	<ul style="list-style-type: none"> <li>• All control versions for two strong muscle signals</li> </ul>	<ul style="list-style-type: none"> <li>• For patients with two strong muscle signals</li> </ul>
	<ul style="list-style-type: none"> <li>• One switch and one 4-stage control element</li> </ul>	<ul style="list-style-type: none"> <li>• Direct switching with the impulse of a 4-stage control element</li> <li>• With automatic switch-back to the hand</li> <li>• Vibration active</li> </ul>	<ul style="list-style-type: none"> <li>• Digital</li> </ul>	<ul style="list-style-type: none"> <li>• Digital</li> </ul>	<ul style="list-style-type: none"> <li>• All control versions for switch control</li> </ul>	<ul style="list-style-type: none"> <li>• For patients with weak or no muscle signals</li> </ul>

# DynamicArm

Programme	Activation	Switching version	DynamicArm flexion/extension	Electric rotator pronation/supination	System Electric Hand and Greifer	Indication
6	<ul style="list-style-type: none"> <li>Two electrodes and one linear control element</li> </ul>	<ul style="list-style-type: none"> <li>Four-channel control</li> </ul>	<ul style="list-style-type: none"> <li>Position control with linear control element</li> </ul>	<ul style="list-style-type: none"> <li>Digital</li> </ul>	<ul style="list-style-type: none"> <li>All control versions for two strong muscle signals</li> </ul>	<ul style="list-style-type: none"> <li>For patients with two strong muscle signals</li> </ul>
7	<ul style="list-style-type: none"> <li>Two electrodes and one linear control element</li> </ul>	<ul style="list-style-type: none"> <li>Co-contraction</li> <li>With automatic switch-back to the hand</li> <li>Vibration active</li> </ul>	<ul style="list-style-type: none"> <li>Position control with linear control element</li> </ul>	<ul style="list-style-type: none"> <li>Proportional</li> </ul>	<ul style="list-style-type: none"> <li>All control versions with two electrodes</li> </ul>	<ul style="list-style-type: none"> <li>For patients with two strong muscle signals</li> </ul>
8	<ul style="list-style-type: none"> <li>Two electrodes and one linear control element</li> </ul>	<ul style="list-style-type: none"> <li>Not applicable</li> </ul>	<ul style="list-style-type: none"> <li>Position control with linear control element</li> </ul>	<ul style="list-style-type: none"> <li>Not applicable</li> </ul>	<ul style="list-style-type: none"> <li>All control versions with two electrodes</li> </ul>	<ul style="list-style-type: none"> <li>For patients with two muscle signals of any strength</li> <li>Simultaneous control of DynamicArm and terminal device possible</li> </ul>
	<ul style="list-style-type: none"> <li>1 switch and 1 linear control element</li> </ul>	<ul style="list-style-type: none"> <li>Not applicable</li> </ul>	<ul style="list-style-type: none"> <li>Position control with linear control element</li> </ul>	<ul style="list-style-type: none"> <li>Not applicable</li> </ul>	<ul style="list-style-type: none"> <li>All control versions for switch control</li> </ul>	<ul style="list-style-type: none"> <li>For patients with weak or no muscle signals</li> </ul>
9	<ul style="list-style-type: none"> <li>One electrode and one linear control element</li> </ul>	<ul style="list-style-type: none"> <li>Not applicable</li> </ul>	<ul style="list-style-type: none"> <li>Position control with linear control element</li> </ul>	<ul style="list-style-type: none"> <li>Not applicable</li> </ul>	<ul style="list-style-type: none"> <li>All control versions with one electrode</li> </ul>	<ul style="list-style-type: none"> <li>For patients with one strong muscle signal</li> <li>Possibility for simultaneous control of DynamicArm and terminal device</li> </ul>



 647H437

## ErgoArm Electronic plus

Art. no. 12K50

ErgoArm Electronic plus with internal electronic lock and Easy Plug (internal electrical connection), AFB flexion aid and upper arm rotation joint (humeral rotation feature), with adjustable friction. Plastic forearm shell (length: 305 mm, circumference: approx. 260 mm) and elbow ball made of beige plastic. The continuous electronic lock can be locked or unlocked either with myoelectric signals (e.g. two electrodes: co-contraction) or by means of a switch. Various programmes that can be accessed via MyoSelect and coloured coding plugs (article no. 13E184=\*) permit individual adaptation of the lock control system to the requirements of the respective user. The slip-stop function makes it possible to lower the forearm in a controlled manner without having to fully release and reactivate the lock (not in all programmes!). The lock can bear a load of up to 230 N at a forearm length of 305 mm. The electrode and battery connection cables can be plugged into the elbow ball. Since there are no external cables, the risk of defects caused by broken cables is reduced and the cosmetic appearance is enhanced. The internal ratchetless lock can be unlocked or locked in any position, even under a load.

### Accessories for 12K50

- Adapter (article no. 13Z68)
- Alignment aid for ErgoArm (article no. 743A23)
- Clamp stopple set (article no. 21A207)
- Forearm (article no. 12K48)
- AFB flexion aid (article no. 12K39)
- Cable harness (article no. 13E187)
- Elbow joint\* (article no. 12A14)
- Strap clamp\* (article no. 13G65)
- Band roller (article no. 13G66)
- Lamination ring (article no. 13Z47)
- Ball cap\* (article no. 13Z48)
- Plug cover set (article no. 13Z49)
- Thread segment\* (article no. 13Z50)
- Hole covering\* (article no. 13Z51)
- Spring telescope (article no. 13Z52)
- Switch cable (article no. 13Z53)
- Lamination protection cover (article no. 13Z54)
- Bracket cover\* (article no. 13Z56)
- Pressure piece\* (article no. 13Z57)
- Eccentric\* (article no. 13Z58)
- Lamination protection cover (article no. 13Z59)
- Countersunk head screw (article no. 501S101=M4X12)
- Countersunk head screw (article no. 501S84=M4X20)
- O-ring (article no. 627F13=60X2.5)
- Fixation fork (article no. 711M51)

\* Marked articles are available in colour no. 11 by adding =1 and colour no. 15 by adding =2 at the end of the article number.

Art. no.	Size	Upper arm connection diameter	Lamination ring diameter	Colour
12K50=45	7-7¼	70 mm	45 mm	4
12K50=45-7	7-7¼	70 mm	45 mm	Black
12K50=50	7¾-8¼	70 mm	50 mm	4
12K50=50-1	7¾-8¼	70 mm	50 mm	11
12K50=50-2	7¾-8¼	70 mm	50 mm	15
12K50=50-7	7¾-8¼	70 mm	50 mm	Black

- The colours roughly correspond to the glove colours according to the 646M3 colour sample set.
- ErgoArm is available in black from 1<sup>st</sup> of July 2019.

Switching mode	Lock	SLIP-STOP	Four-channel processor II	Hand
1	<b>White</b> <ul style="list-style-type: none"> <li>• Press switch ▶ release = lock</li> <li>• Press switch ▶ release = unlock</li> </ul>	• NO	• All switching modes	• All versions
2	<b>Red</b> <ul style="list-style-type: none"> <li>• Contraction = lock</li> <li>• Contraction = unlock</li> </ul>	• NO	• Only programme 1 (white) four-channel control or programme 9 adjustment cap	• All versions with 2 electrodes
3	<b>Green</b> <ul style="list-style-type: none"> <li>• Press and hold down switch = elbow mode</li> <li>• Electrode OPEN = unlock</li> <li>• Electrode CLOSE = lock</li> <li>• Release switch = hand mode</li> </ul>	• YES	• All switching modes	• All versions with 2 electrodes
4	<b>Blue</b> <ul style="list-style-type: none"> <li>• Press switch ▶ release = elbow mode</li> <li>• Electrode OPEN = unlock</li> <li>• Electrode CLOSE = lock</li> <li>• Press switch ▶ release = hand mode</li> </ul>	• YES	• All switching modes	• All versions with 2 electrodes
5	<b>Yellow</b> <ul style="list-style-type: none"> <li>• Press switch ▶ release = elbow mode</li> <li>• Electrode OPEN = unlock</li> <li>• Electrode CLOSE = lock</li> <li>• 10 s no electrode signal = hand mode</li> <li>• or press switch ▶ release = hand mode</li> </ul>	• YES	• All switching modes	• For patients with one strong electrode signal or tendency to co-contraction
6	<b>Purple</b> <ul style="list-style-type: none"> <li>• Co-contraction = elbow mode</li> <li>• Electrode OPEN = unlock</li> <li>• Electrode CLOSE = lock</li> <li>• Co-contraction = hand mode</li> </ul>	• YES	• Only programme 1 (white) four-channel control or programme 9 adjustment cap	• Not recommended for hands with digital or Digital Twin control
7	<b>Orange</b> <ul style="list-style-type: none"> <li>• Co-contraction = elbow mode</li> <li>• Electrode OPEN = unlock</li> <li>• Electrode CLOSE = lock</li> <li>• 10 s no electrode signal = hand mode</li> <li>• or co-contraction = hand mode</li> </ul>	• YES	• Only programme 1 (white) four-channel control or programme 9 adjustment cap	• Not recommended for hands with digital or Digital Twin control

• Vibration signal feedback for successful switching between hand and elbow is provided in programmes 3–7.

1x vibration = hand mode (electrode signals control the hand)

2x vibration = elbow mode (electrode signals control the elbow)



 647H437

## ErgoArm Hybrid plus

Art. no. 12K44

ErgoArm Hybrid plus with internal ratchetless lock, AFB flexion aid and upper arm rotation joint (humeral rotation feature), with adjustable friction. Plastic forearm shell (length: 305 mm, circumference: approx. 260 mm) and elbow ball made of beige plastic. The slip-stop function makes it possible to lower the forearm in a controlled manner without having to fully release and reactivate the lock. The lock can bear a load of up to 230 N at a forearm length of 305 mm. The electrode and battery connection cables can be plugged into the elbow ball. Since there are no external cables, the risk of defects caused by broken cables is reduced and the cosmetic appearance is enhanced. The internal ratchetless lock can be unlocked or locked in any position, even under a load.

### Accessories for 12K44

- Adapter (article no. 13Z68)
- Alignment aid for ErgoArm (article no. 743A23)
- Clamp stopple set (article no. 21A207)
- Forearm (article no. 12K48)
- AFB flexion aid (article no. 12K39)
- Cable harness (article no. 13E187)
- Elbow joint\* (article no. 12A14)
- Strap clamp\* (article no. 13G65)
- Band roller (article no. 13G66)
- Lamination ring (article no. 13Z47)
- Ball cap\* (article no. 13Z48)
- Plug cover set (article no. 13Z49)
- Thread segment\* (article no. 13Z50)
- Hole covering\* (article no. 13Z51)
- Spring telescope (article no. 13Z52)
- Switch cable (article no. 13Z53)
- Lamination protection cover (article no. 13Z54) <sup>5</sup>
- Bracket cover\* (article no. 13Z56) <sup>2</sup>
- Pressure piece\* (article no. 13Z57)
- Eccentric\* (article no. 13Z58)
- Lamination protection cover (article no. 13Z59) <sup>4</sup>
- Countersunk head screw (article no. 501S101=M4X12)
- Countersunk head screw (article no. 501S84=M4X20)
- O-ring (article no. 627F13=60X2.5) <sup>3</sup>
- Fixation fork (article no. 711M51) <sup>1</sup>

\* Marked articles are available in colour no. 11 by adding =1 and colour no. 15 by adding =2 at the end of the article number.

Art. no.	Size	Upper arm connection diameter	Lamination ring diameter	Colour
12K44=45	7–7¼	70 mm	45 mm	4
12K44=45-7	7–7¼	70 mm	45 mm	Black
12K44=50	7¾–8¼	70 mm	50 mm	4
12K44=50-1	7¾–8¼	70 mm	50 mm	11
12K44=50-2	7¾–8¼	70 mm	50 mm	15
12K44=50-7	7¾–8¼	70 mm	50 mm	Black

- The colours roughly correspond to the glove colours according to the 646M3 colour sample set.
- ErgoArm is available in black from 1<sup>st</sup> of July 2019.



## ▶ Shoulder joints

### MovoShoulder Swing

Art. no. 12S6

This shoulder joint opens up new possibilities for prosthetic fittings in the shoulder area. The MovoShoulder Swing is ideal for prostheses with basic functions or in combination with high-tech components. The free swing of up to 40° reduces pressure from the prosthetic socket and allows even bilateral amputees to achieve natural, harmonious movements. Locking at 30° anteversion and unlocking is controlled by specific upper body motions or with the sound hand. No additional control elements such as switches or a body harness are required. Abduction of up to 20° facilitates more comfortable movement patterns during many activities of daily life. This especially applies to activities done close to the body or while sitting.

Art. no.	Side
12S6=L	Left (L)
12S6=R	Right (R)

#### Technical data

Overall length	230 mm
Weight	242 g

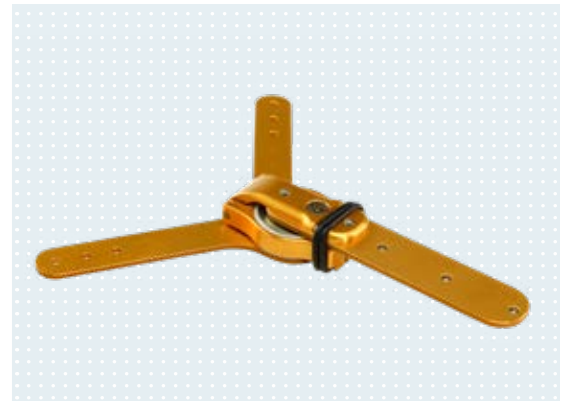

647G349



#### Tip

- This joint can also be fitted in conjunction with the DynamicArm (article no. 12K100N and 12K110N).

### Shoulder joint

Art. no. 12S4

This shoulder joint has two axes with separate friction and two arm bars.

#### Technical data

Overall length	220 mm
Lamination ring diameter	43 mm
Weight	134 g

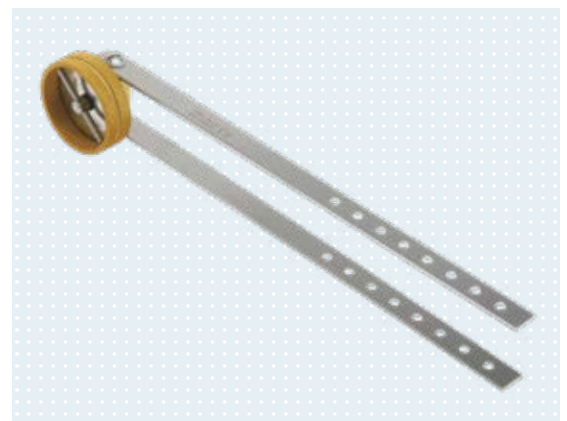

647G473

**i** The lamination ring, O-ring and shoulder bracket are found on page 195.

## ▶ Electrodes and accessories

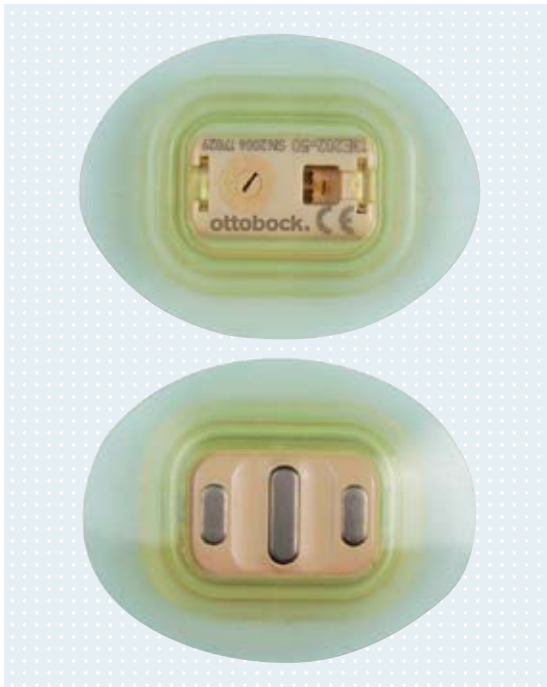

647G334

### Suction socket electrode

Art. no. 13E202

This generation of electrodes is based on the familiar 13E200 electrode. Embedded into a mounting suspension of elastic material, this electrode creates an airtight seal between the inner socket and outer socket. If used correctly, the suction socket electrode (article no. 13E202) also prevents perspiration from penetrating between the outer and inner socket, therefore effectively preventing damage to the electrical and mechanical components caused by corrosion.

The suction socket electrode can not only be used for standard sockets, but is also particularly suitable for application in elevated vacuum sockets. Combining the suction socket electrode with a tube valve (article no. 12V10) for an elevated vacuum socket creates a vacuum effect in the socket, optimising the hold of the residual limb in the socket. As with the 13E200 electrode, state-of-the-art shielding and filtering technologies also largely protect the 13E202 suction socket electrode against high frequency interference caused, for example, by mobile phones, walkie-talkies, computers or anti-theft systems in shopping centres so that the proper control of the myoelectrically controlled prosthesis is not affected.

The electrode contacts are made from pure titanium and are therefore suitable for people with allergies as well. The frequency filter's full protection effect will only be provided if the mains frequency and filter frequency are identical.

Art. no.	HZ	Frequency bandwidth	Room temperature	Operating voltage U
13E202=50	50	90–450 Hz	-15 to +60°C	4.8–7.2 V
13E202=60	60	90–450 Hz	-15 to +60°C	4.8–7.2 V

- Use silicone grease (article no. 633F11) to seal the plug connection. Remove any excess grease after connecting the electrode cable.
- Tube valve (article no. 12V10), see page 91.



### Electrode

Art. no. 13E200

These MyoBock electrodes are particularly sensitive in the range of low muscle signals. The change in amplification now takes place logarithmically, which enables enhanced differentiation of the signal level. Thanks to modern frequency shielding and filtering technologies, they are less sensitive to low and high frequency interferences that are emitted, for example, by mobile phones or shopping centre security systems. The electrode contacts are made from pure titanium and are therefore suitable for people with allergies as well. The electrode accessories for laminated inner sockets (article no. 13E153) and for vacuum-formed inner sockets (article no. 13E201) are included in the scope of delivery. The frequency filter's full protection effect will only be provided if the mains frequency and filter frequency are identical.

Art. no.	HZ	Frequency bandwidth	Room temperature	Operating voltage U
13E200=50	50	90–450 Hz	-15 to +60°C	4.8–7.2 V
13E200=60	60	90–450 Hz	-15 to +60°C	4.8–7.2 V

- Use silicone grease (article no. 633F11) to seal the plug connection. Remove any excess grease after connecting the electrode cable.

## ▶ Electrodes and accessories

### Electrode accessories set

Art. no. 13E206

Suitable for suction socket electrodes (article no. 13E202).

#### Consisting of

- Casting template for inner socket (article no. 13E203)
- Lamination disc, serrated (article no. 507S15)
- Socket screw with Allen head (article no. 503F3)
- Sensitivity adjustment tool (article no. 13E80)
- Casting template for outer socket (article no. 13E204)



### Electrode accessories

Art. no. 13E153

For laminated inner sockets with electrode (article no. 13E200). Use an Allen wrench (article no. 709S10=2) for socket screws (article no. 503F3).

#### Consisting of

- Template for inner socket (article no. 13E191)
- Casting template for outer socket (article no. 13E192)
- 2x lamination discs, serrated (article no. 507S15)
- 2x socket screws with Allen head (article no. 503F3)
- Sensitivity adjustment tool (article no. 13E80)

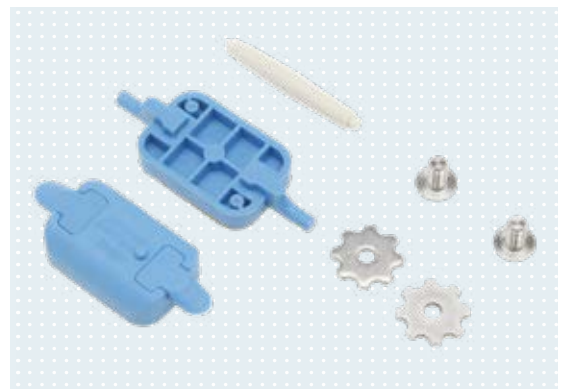

### Electrode accessories

Art. no. 13E201

For vacuum-formed inner sockets with electrode (article no. 13E200). Only available as a set. The electrode mounting brackets and setting nuts (article no. 29C5=M4X9) can also be ordered individually.

#### Consisting of

- One template for the inner and outer socket each
- Lamination dummy for electrode mounting bracket
- Electrode mounting bracket, beige (article no. 13E172)
- Setting nut (article no. 29C5=M4X9)



### Electrode mounting bracket set

Art. no. 13E135

The electrode mounting bracket set is intended for positioning and assembling MyoBock electrodes on the interim plaster or ThermoLyn socket (article no. 616T52 or 616T53), and is suitable for electrodes (article no. 13E200).



## ▶ Battery management and accessories

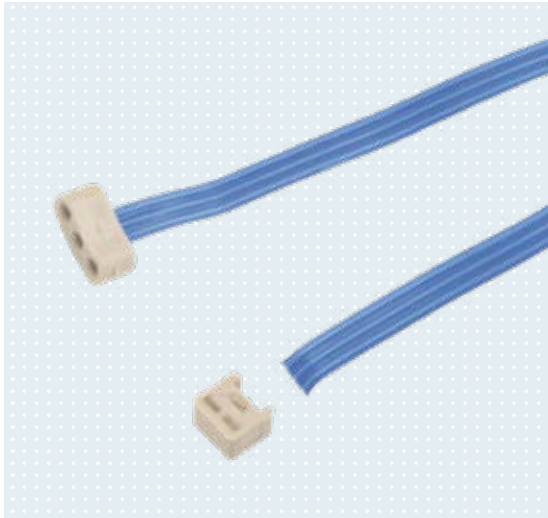

### Electrode cable with straight plug and plug connector

Art. no. 13E129=G\*

Electrode cable for connecting the electrode (article no. 13E200/13E202) or the control element (article no. 9X52, 9X53 and 9X54) with the coaxial plug (article no. 9E169), the switch block (article no. 13E190), the electric rotator (article no. 10S17), the MyoRotronic (article no. 13E205) or the elbow (article no. 12K44/12K50/12K100N/12K110N).

Art. no.	Length
13E129=G100	100 mm
13E129=G300	300 mm
13E129=G600	600 mm
13E129=G1000	1,000 mm

◻ The 13E121 plug connector is included in the scope of delivery!

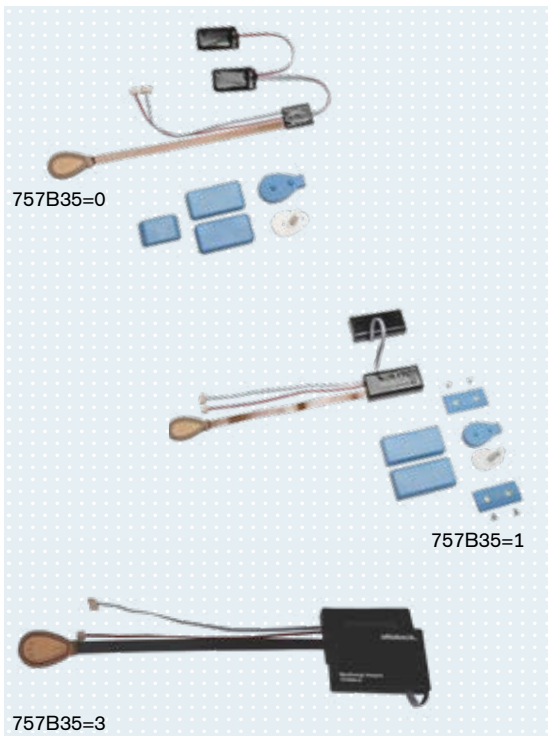

### MyoEnergy Integral

Art. no. 757B35=\*

The MyoEnergy Integral (article no. 757B35=\*) is an integrated power supply system made up of several components. The charging receptacle has contacts for the battery, indicates the current charge level and allows the prosthesis to be switched on and off and opened in an emergency. The communication cable with a 3-pin receptacle is used for the exchange of data. The supply cable establishes the connection between the battery and the respective prosthetic component. The battery consists of two cells with different capacities. Suitable for the MyoBock system.

#### Consisting of

- Lamination dummy, battery
- Lamination dummy for charging receptacle
- Drilling template for charging receptacle

Technical data	Art. no. 757B35=0	Art. no. 757B35=1	Art. no. 757B35=3
Capacity	300 mAh	600 mAh	1,150 mAh
Output voltage	approx. 7.4 V	approx. 7.4 V	approx. 7.4 V
Charging time	approx. 2.5 h	approx. 2.5 h	approx. 2.5 h
Technology	Lithium polymer	Lithium polymer	Lithium-ion
Dimensions approx.	35x20x20 mm	2x 52x25x10 mm	2x 52x36x9 mm

◻ The dummy sets for article no. 757B35=0, 757B35=1, 757B35=3, 757B35=5 can be ordered via the article no. 757Z276=\*

# ▶ Battery management and accessories

## MyoCharge Integral

Art. no. 757L35

The MyoEnergy Integral integrated into the socket is charged using the MyoCharge Integral (article no. 757L35). Simply place the charging plug against the charging receptacle on the outside of the prosthetic socket. Thanks to an integrated magnet, the charging plug can be easily attached to the charging receptacle. The special contour of the charging receptacle and charging plug assures the quick, reliable positioning of the two components to each other. LEDs indicate the readiness of the battery charger and the current charge level.

### Technical data

Operating temperature	0 to +60°C
Storage temperature	-20 to +60°C
Supply voltage	100–240 V
Mains frequency	50–60 Hz

- The MyoCharge Integral can be used for all versions of the MyoEnergy Integral (article no. 757B35=0, 757B35=1, 757B35=3 and 757B35=5).
- The universal power supply (article no. 757L16-4) is included in the scope of delivery!



647G534

## EnergyPack

Art. no. 757B2\*

The EnergyPack is suitable for integration into all socket types of the MyoBock system, even in case of long residual limbs. Compared to Ni-Cd batteries, Li-ion batteries have a lower self-discharge level, higher cell voltage and greater capacity. They have no memory effect.

Technical data	Art. no. 757B20	Art. no. 757B21
Capacity	900 mAh	680 mAh
Charging time (full charge)	approx. 3.5 h	approx. 3 h
Technology	Lithium-ion	Lithium-ion
Weight	65 g	51 g

- Can only be used for the MyoBock adult system.
- The following colours are available: -3 corresponds to black, -2 corresponds to colour 15, -1 corresponds to colour 11, no colour code corresponds to colour 4.

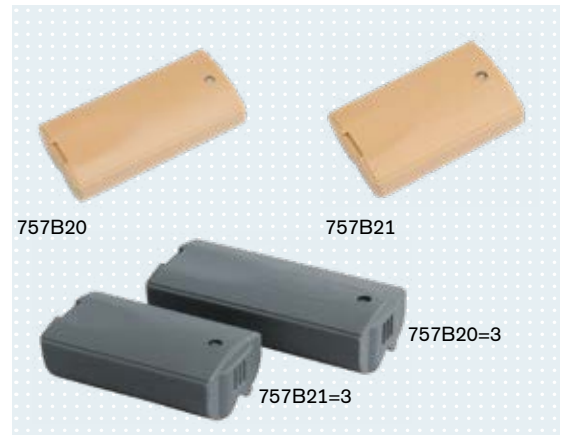

647H356

## Li-ion charger

Art. no. 757L20

Li-ion charger for charging one or two EnergyPacks (article no. 757B20/757B21). Housing made of impact resistant plastic material, including universal power supply (article no. 757L16-4) with EU and additional US plug. The design conforms to recommended standards, protection class II.

### Technical data

Operating temperature	0 to +50°C
Mains frequency	47–63 Hz
Supply voltage	100–240 automatic adjustment V/AC
Charging time for EnergyPacks	approx. 3.5 h (757B20) 3 h (757B21)



647H357



## ▶ Battery management and accessories



647H369

### Battery receptacle set

Art. no. 757Z184=1

Battery receptacle set for EnergyPack (article no. 757B20).

#### Consisting of

- Spacer insert (article no. 757Z188-1)
- Battery receptacle (article no. 757Z185=1)
- Locking lever (article no. 757Z186)
- Casting template (article no. 757Z187=1)
- Foil template (article no. 757Z189=1)



### Battery receptacle

Art. no. 757Z185=1

Battery receptacle without locking lever for EnergyPack (article no. 757B20).



### Battery receptacle set

Art. no. 757Z184=2

Battery receptacle set with screw clamp connection for quick removal from socket. With integrated connection sockets for electrodes, hand cables or for connection cables (article no. 757P41 and 757P39) for connecting to the MyoBoy.

#### Consisting of

- Battery receptacle (article no. 757Z185=2)
- Locking lever (article no. 757Z186)
- Casting template (article no. 757Z187=1)
- Foil template (article no. 757Z189=1)
- Plug (article no. 757Z202)
- Set screw (article no. 506G1=M3X10)



### Battery receptacle

Art. no. 757Z185=2

Battery receptacle with screw clamp connection, without locking lever, for EnergyPack (article no. 757B20). Notice: Please use the 757P41 connection cable here!

#### Consisting of

- Plug (article no. 757Z202)
- Set screw (article no. 506G1=M3X10)



## ▶ Battery management and accessories

### Battery receptacle set

Art. no. 757Z190=1

Battery receptacle set for EnergyPack (article no. 757B21).

#### Consisting of

- Spacer insert (article no. 757Z193=1)
- Battery receptacle (article no. 757Z191=1)
- Locking lever (article no. 757Z186)
- Casting template (article no. 757Z192=1)
- Foil template (article no. 757Z194=1)



 647H369

### Battery receptacle

Art. no. 757Z191=1

Battery receptacle without locking lever, for 757B21 EnergyPack.

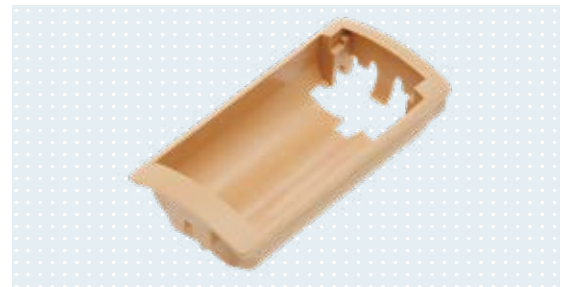

### Battery receptacle set

Art. no. 757Z190=2

With screw clamp connection for quick removal from socket. Integrated connection sockets for electrodes, hand cables or connection cables (article no. 757P41 and 757P39) for connecting to the MyoBoy. For EnergyPack (article no. 757B21).

#### Consisting of

- Battery receptacle (article no. 757Z191=2)
- Locking lever (article no. 757Z186)
- Casting template (article no. 757Z192=1)
- Foil template (article no. 757Z194=1)
- Plug (article no. 757Z202)
- Set screw (article no. 506G1=M3X10)



 647H492

### Battery receptacle

Art. no. 757Z191=2

Battery receptacle with screw clamp connection, without locking lever, for EnergyPack (article no. 757B21). Notice: Please use the 757P41 connection cable here!

#### Consisting of

- Plug (article no. 757Z202)
- Set screw (article no. 506G1=M3X10)



## ▶ Battery management and accessories

---



### Locking lever

Art. no. 757Z186

Locking lever for battery receptacle (article no. 757Z184 and 757Z190).



### Locking lever

Art. no. 757Z195

Locking lever for bilateral amputees with enlarged release lever for increased user comfort.



### Plug

Art. no. 757Z202

Notice: Plug for battery compartment with screw connection!

## ▶ Battery management and accessories

### Car charging cable, 12 volt

Art. no. 4X74

Two EnergyPacks (article no. 757B20/757B21) can be charged via the cigarette lighter socket. Suitable for the MyoBock charger (article no. 757L20).



### Universal power supply

Art. no. 757L16-4

Universal power supply for the MyoBock battery chargers (article no. 757L35 and 757L20), with exchangeable EU and US plugs.



### Adapter for Australia

Art. no. 757S1=AUS-4

Adapter for Australia. Recommended for travel.



### Adapter for Great Britain

Art. no. 757S1=GB-4

Adapter for Great Britain. Recommended for travel.

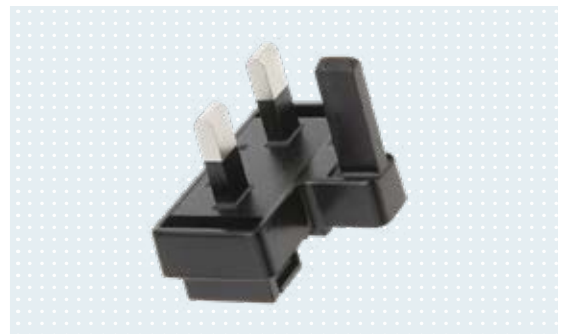

## ▶ Cables and accessories

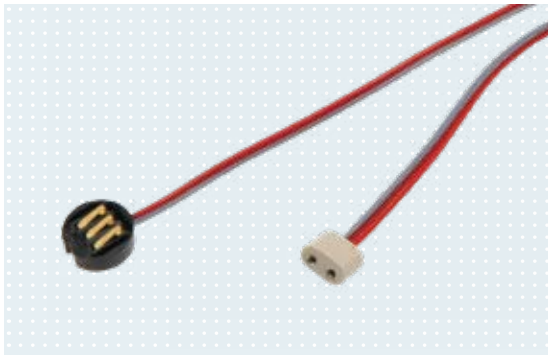

### Battery connection cable

Art. no. 13E188

Battery connection cable for EnergyPack to connect the battery receptacle (article no. 757Z185=1 or 757Z191=1) with coaxial plug (article no. 9E169), electric rotator (article no. 10S17), MyoRotronic (article no. 13E205) or switch block (article no. 13E190 or 13E190=150).

Art. no.	Length
13E188=200	200 mm
13E188=600	600 mm

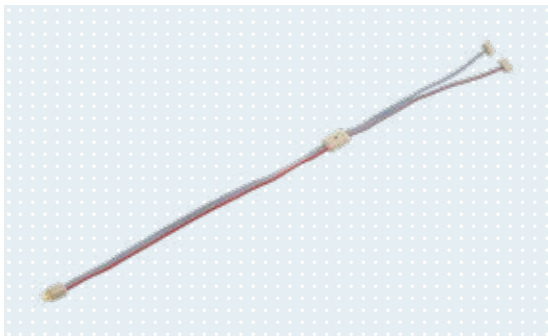

### Connection cable

Art. no. 757P41

Battery connection cable to connect the battery receptacle (article no. 757Z185=2 or 757Z191=2) and coaxial plug (article no. 9E169) or MyoRotronic (article no. 13E205).



### Switch block

Art. no. 13E190

Switch block to connect the EnergyPack (article no. 757B20 or 757B21), electrodes (article no. 13E200 or 13E202) and System Electric Hands with hand cable (article no. 9E53), without extension cable.

- Apply silicone grease (article no. 633F11) to the bushings prior to connection: provides corrosion protection!



### Switch block

Art. no. 13E190=150

Switch block to connect the EnergyPack (article no. 757B20 or 757B21), electrodes (article no. 13E200 or 13E202) and System Electric Hands with hand cable (article no. 9E53) and extension cable. Length: 150 mm.

- Apply silicone grease (article no. 633F11) to the bushings prior to connection: provides corrosion protection!

## ▶ Cables and accessories

### Connection cable

Art. no. 13E50

Connection cable to control electric pronation and supination with the electric rotator (article no. 10S17). Used to provide the electrical connection between the electric rotator and harness pull switch (article no. 9X14), cable pull switch (article no. 9X18) or rocker switch (article no. 9X25).

Art. no.	Length
13E50=250	250 mm
13E50=1200	1,200 mm

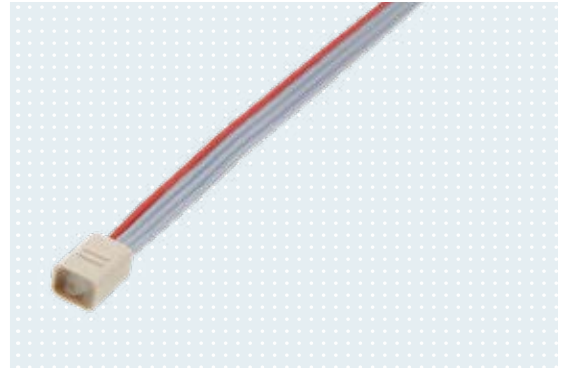

### Connection cable with on/off switch

Art. no. 13E97

Pronation and supination function can be turned off using the switch. The connection cable is used to provide the electrical connection between the electric rotator (article no. 10S17) and harness pull switch (article no. 9X14), cable pull switch (article no. 9X18) or rocker switch (article no. 9X25).

Art. no.	Length
13E97=250	250 mm
13E97=1200	1,200 mm

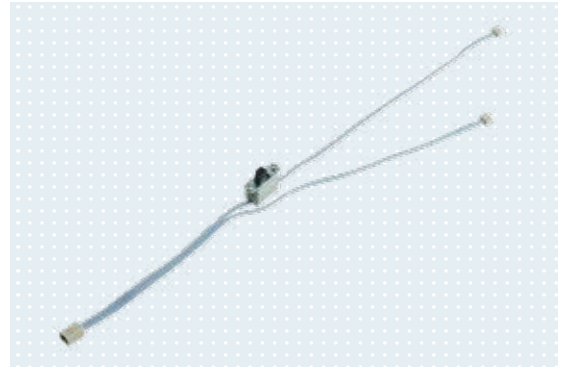

### Connection cable

Art. no. 13E99=1200

Connection cable to control the opening and closing movements of the System Electric Hand (article no. 8E38=9, 8E38=7, 8E38=8) or System Electric Greifer (article no. 8E33=\*). The connection cable is used for the electrical connection between the coaxial plug or electric rotator and harness pull switch (article no. 9X14), cable pull switch (article no. 9X18), rocker switch (article no. 9X25) or pressure switch (article no. 9X37). (Length: 1,200 mm).

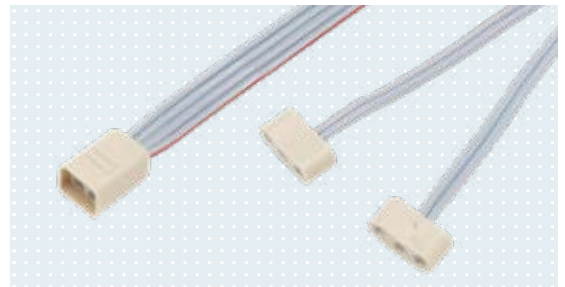

## ▶ Cables and accessories

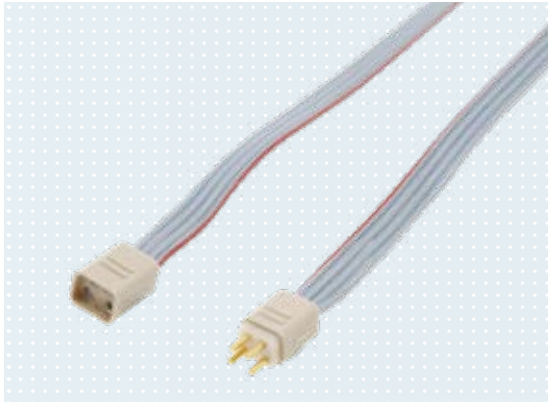

### Extension cable

Art. no. 9E185

Extension cable to extend the hand cable of the System Electric Hand (article no. 8E39, 8E41, 8E44) or System Electric Greifer (article no. 8E34) and connect to the battery receptacle (article no. 757Z185=2 or 757Z191=2).

Art. no.	Length
9E185=30	300 mm
9E185=40	400 mm
9E185=50	500 mm
9E185=50=1	500 mm

- ▶ Apply silicone grease (article no. 633F11) to the cable bushings prior to connection.
- ▶ Notice: The 9E185=50-1 extension cable has a partial tube sheathing and a sealing ring. It can be used in conjunction with the 12K5 and 12K20 elbow components for simple myoelectric prostheses.



## ▶ Control elements

### Control element

Art. no. 9X51/9X53

The linear control element (article no. 9X51) for installation in a harness system allows continuous, proportional control of prosthetic components using harnesses. The 4-stage control element (article no. 9X53) allows for proportional control of prosthetic components at four different speed levels using harnesses. In combination with the DynamicArm (article no. 12K100N), it offers the possibility to switch specifically between the various system components.

#### Technical data

Cable travel	8 mm
Max. actuating force	10 N
Weight	6 g

• Connection cable (article no. 13E129=G\*), see page 87.



647H475

### Control element

Art. no. 9X50/9X52

The linear control element (article no. 9X50) for installation between the outer and inner socket of the prosthesis allows continuous, proportional control of prosthetic components using harnesses. The 4-stage control element (article no. 9X52) allows for proportional control of prosthetic components at four different speed levels using harnesses. In combination with the DynamicArm (article no. 12K100N), it offers the possibility to switch specifically between the various system components. The pull cable (article no. 10Y35) can be ordered separately.

#### Technical data

Cable travel	8 mm
Max. actuating force	10 N
Weight	11 g

• Connection cable (article no. 13E129=G\*), see page 87.



647H485

### Harness pull switch

Art. no. 9X14

The harness pull switch (weight: 19 g) for use within a harness or as a cable pull switch is used to control the electric rotator (article no. 10S17), System Electric Hand (article no. 8E38=7, 8E38=8 and 8E38=9) or System Electric Greifer (article no. 8E33=9). The control cables can be connected after loosening the cover. Functional sequence: off – function 1 – function 2.

#### Scope of delivery

- 4 cap screws (article no. 501T16=M2X6)
- Connection cable see page 87.



647G400

## ▶ Control elements

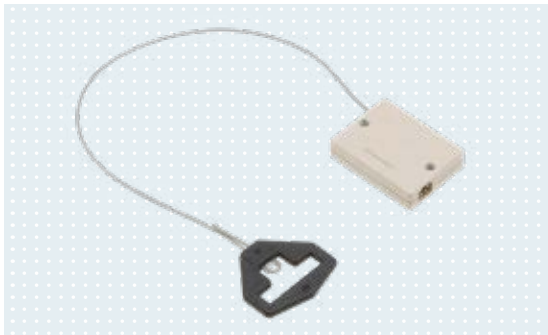

647G401

### Cable pull switch

Art. no. 9X18

The cable pull switch (weight: 17 g) with steel cable, bow and wedge lock is for standard applications. The switch housing is attached to the socket with screws and the steel cable is connected to the harness or another pull cable so that the electric rotator (article no. 10S17), System Electric Hand (article no. 8E38=7, 8E38=8, 8E38=9 and 8E12) or System Electric Greifer (article no. 8E33=\*) can be controlled. Functional sequence: off – function 1 – function 2.

#### Scope of delivery

- 2x oval head screws (article no. 501S46=M3X5)
- 2x oval head screws (article no. 501S46=M3X8)

• Connection cable see page 87.

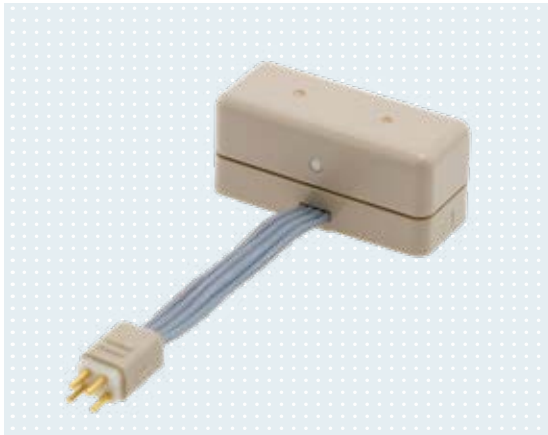

647G402

### Rocker switch

Art. no. 9X25

Rocker switch with four-conductor flat cable coming out the side, with female connector, for controlling the electric rotator (article no. 10S17), System Electric Hand (article no. 8E38=7, 8E38=8 and 8E38=9), System Electric Greifer (article no. 8E33=\*).

#### Connection cable

- For opening and closing movements: connection cable (article no. 13E99)
- For pronation and supination: connection cable (article no. 13E50 or article no. 13E97)

#### Scope of delivery

- Oval head screw (article no. 501S46=M2X8 and article no. 501S46=M2X5)

• Connection cable see page 87.



647H71

### Pressure switch

Art. no. 9X37

Pressure switch for controlling the System Electric Hand (article no. 8E38=\*), System Electric Greifer (article no. 8E33=\*) or electric rotator (article no. 10S17) in combination with the MyoRotronic (article no. 13E205). The switch's special feature allows the separate adjustment of both control points.

#### Scope of delivery

- Oval countersunk head screw (article no. 501S75=M2X8 and article no. 501S75=M2X5)

#### Connection cable

- Use the connection cable (article no. 13E99) for the control of opening and closing movements.

• Connection cable (article no. 13E99=1200), see page 87.

## ▶ Accessories

### Tube valve for elevated vacuum socket

Art. no. 12V10

In combination with the MyoBock electrode (article no. 13E202), the tube valve creates an airtight socket seal.

- The PVC connection tube (article no. 99B13) is already included in the scope of delivery.



### PVC connection tube

Art. no. 99B13

The PVC connection tube serves as a connection channel between the inner and outer sockets.

Art. no.	Colour	Diameter
99B13=16	Beige	16 mm
99B13=16-7	Black	16 mm
99B13=21	Beige	21 mm
99B13=21-7	Black	21 mm



### Tube dummies

Art. no. 99B83

The tube dummies are used for fabricating vacuum-formed inner sockets.

Art. no.	Diameter
99B83=16	16 mm
99B83=21	21 mm

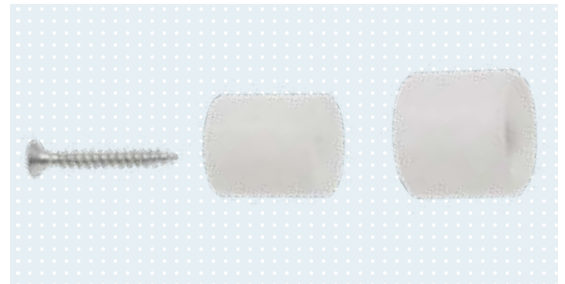

### Magnetic centring aid

Art. no. 711M77

The magnetic centring aid allows technicians to precisely determine the centre point of the PVC connection tube outside the outer socket in order to then mill the cut-out exactly. The centring aid is also highly elastic, which permits straightforward positioning in the inner socket.

- Please note that the 711M77=1 is intended for the 7.4 V Kids system and the 711M77=2 for the MyoBock and Axon-Bus systems.

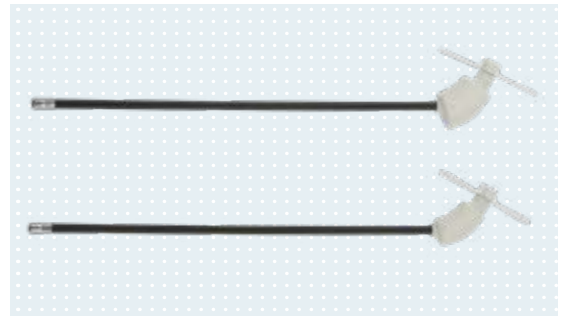



646D315

646G461

## PAULA

Art. no. 646C52

PAULA is a comprehensive software package which provides essential support for fabricating upper limb prostheses. The software assists O&P professionals with the planning, socket design and construction of myoelectrically controlled prostheses, hybrid prostheses, cable-controlled prostheses and passive prostheses. The integration into the Ottobock Data Station provides a common platform, offering O&P professionals a familiar user interface.

• If you have questions related to installation, please contact our O&P Hotline employees!



## MyoBoy

Art. no. 757M11=X-Change

The MyoBoy provides optimum support for the O&P professional and patient when training muscle activity and for the realistic simulation of the MyoBock systems. The data that are collected allow the selection of the most suitable control system for the individual fitting.

### Consisting of

- MyoBoy device with USB connection
- Quick reference guide (article no. 647G265=1)
- Ground electrode (article no. 757Z18)
- Electrode adapter (article no. 757P44)
- Electrode armband (article no. 757Z174)
- Screwdriver
- USB cable
- Carrying case

### Optional

- Test adapter (article no. 757P23)
- MyoBoy communication cable (article no. 757P39)



## MyoBoy light set

Art no. 757M11=2-K50

The MyoBoy light set assists the therapist when assessing myo-signals in order to determine optimal electrode positions for myoelectric prostheses. It can also be used for muscle training.

### Consisting of

- MyoBoy light (1 pc; article no. 757M11=2)
- MyoBock electrode (2 pc; article no. 13E200=50)
- Electrode cable (2 pc; article no. 13E129=G600)
- Electrode armband (1 pc, article no. 757Z174)

### BionicLink

Art. no. 60X5

The BionicLink PC (article no. 60X5) supports wireless data communication between Ottobock products with a Bluetooth interface (e.g. DynamicArm) and a PC with USB port or USB hub.

#### The BionicLink is equipped with two LEDs

- The green LED indicates that the device is ready for use
- The blue LED indicates that a proper connection has been established between the product and the PC

A proper connection between the Ottobock product and a PC can only be established using corresponding Ottobock software products (e.g. ElbowSoft).



### ElbowSoft

Art. no. 646C42

The “ElbowSoft” software is to be used exclusively for adjusting the DynamicArm and any Ottobock system components connected to it: System Electric Hands (article no. 8E38=\*), System Electric Greifers (article no. 8E33=\*), electric rotator (article no. 10S17), within the scope of an exoprosthesis fitting. Participation in Ottobock product training for the DynamicArm software is mandatory prior to using the product for the first time. To qualify for software updates, additional product training courses may be necessary.



647G341

### MyoSelect

Art. no. 757T13

The MyoSelect (article no. 757T13) is used to identify and adjust MyoBock components, such as System Electric Hands, System Electric Greifers, the MyoRotronic and ErgoArm Electronic plus. The MyoSelect is connected to the MyoBock component and then displays information on the type of component and the currently selected control mode on the integrated display. The multi-function button on the side can be used to select and adjust alternative control devices. It is also possible to adjust the speed of the MyoHand VariPlus Speed, SensorHand Speed and DMC VariPlus System Electric Greifer to the individual needs of the patient using the MyoSelect. Please note that in order to be able to make adjustments with the MyoSelect, the components must be equipped with a black coding plug first! Components such as the MyoHand VariPlus Speed and DMC VariPlus System Electric Greifer are only designed for use with the MyoSelect (article no. 757T13) and the MyoRotronic (article no. 13E205)!



## ▶ Software

---

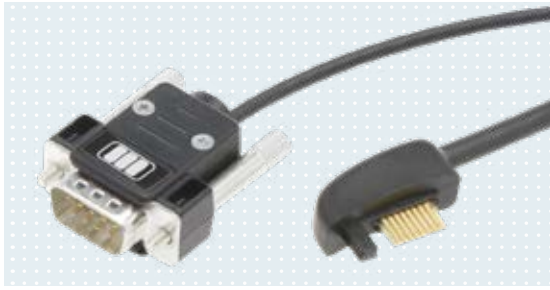

### MyoBoy communication cable

Art. no. 757P39

The MyoBoy communication cable connects the MyoBoy and battery receptacle (article no. 757Z185=2 or 757Z191=2), and permits signal measurement while the complete prosthesis is in use by the patient.

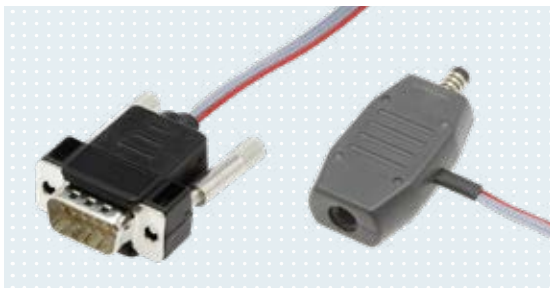

### Test adapter

Art. no. 757P23

Test adapter for the System Electric Hand (article no. 8E38) and System Electric Greifer (article no. 8E33).



## ▶ Service parts

### Fingertip set

Art. no. 9S138

Fingertip set for use without tip padding.

#### Consisting of

- Fingertip (pair)
- Fingertip blank pair (501S54=M3.3x8)
- Oval head screw (2 pieces)



### Rubber gripping pad set

Art. no. 9S145

#### Consisting of

- Tip padding (pair) (9S146)
- Rubber pad (pair) (9S147=1PAA)
- Rubber pad (pair) (9S147=2PAA)
- Padded band (9S148)
- Fingertip blank set (9S149)

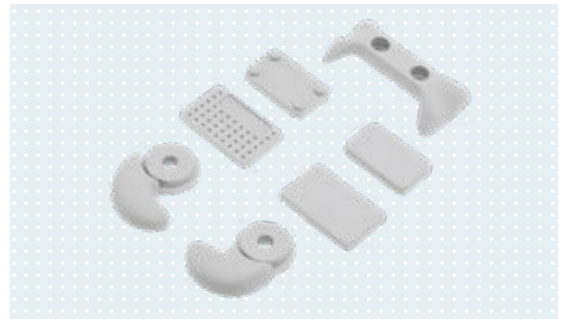

### Fingertip blank set

Art. no. 9S149

The fingertip blank set is used for subsequent adaptation to special tasks.

#### Consisting of

- Stamped part (2 pieces)
- Fingertip blank pair (501S54=M3.3x8)
- Oval head screw (2 pieces)



### Fingertip pair

Art. no. 9S234=PAA

Fingertip pair for use with tip padding.

#### Consisting of

- Fingertip blank pair (501S54=M3.3x8)
- Oval head screw (2 pieces)



## ▶ Service parts

---



### Fingertip pair

Art. no. 9S278=PAA

Fingertip pair for use without tip padding.

**Consisting of**

- Fingertip blank pair (501S54=M3.3x8)
- Oval head screw (2 pieces)

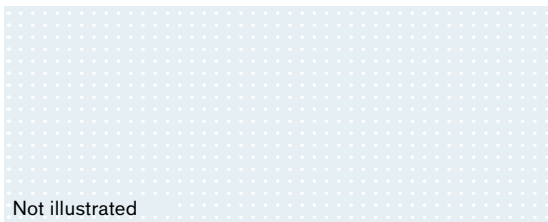

Not illustrated

### Battery cover

Art. no. 9S312

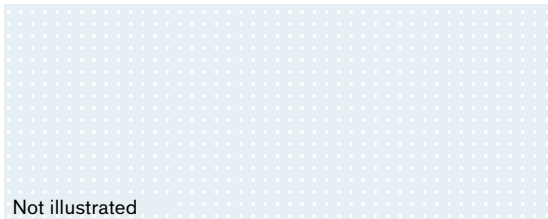

Not illustrated

### Padded band

Art. no. 9S148-1



### Notched plate with inner gear teeth

Art. no. 11S6-1

## ▶ Service parts

---

### Thrust washer

Art. no. 11S7

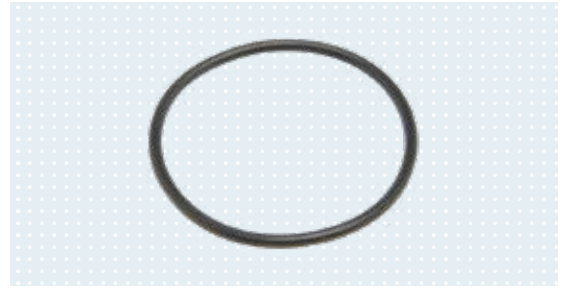

### Washer

Art. no. 11S27

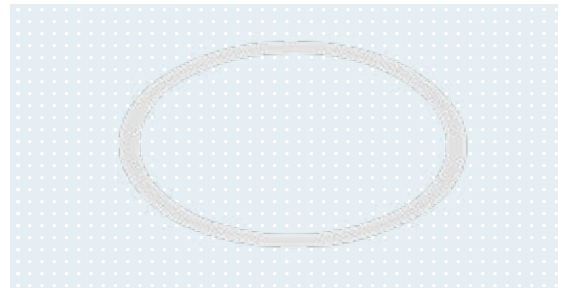

### Friction ring with inner gear teeth

Art. no. 11S30-1

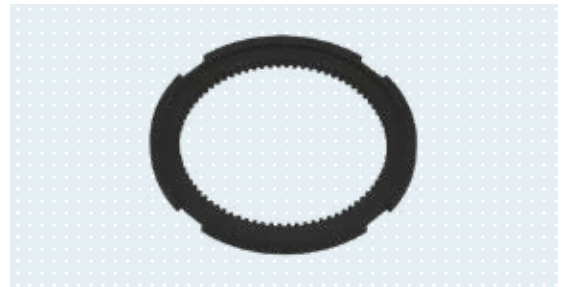



# Axon-Bus System

## Perfect use of precision technology

The Axon-Bus system is a new system for transradial and transhumeral prostheses. Axon stands for Adaptive eXchange Of Neuroplacement data. The Axon-Bus itself is a new Ottobock development for the field of exoprosthetics. It was derived from safety-related bus systems in the aviation and automotive industries and represents a true innovation from our Research and Development department.

The advantage is that it constitutes an optimised, self-contained data transmission system. The individual components communicate with each other perfectly, eliminating losses in terms of data transmission, speed and functionality. This results in a clear plus in safety and reliability for the user. Compared to conventional systems, this is achieved by a significant reduction in sensitivity to outside interference. In combination with the Michelangelo hand, the Axon-Bus prosthetic system offers more degrees of freedom than ever before. The user benefits from enhanced hand functionality. The modular prosthesis solution can be expanded with additional Axon-Bus components in future.

### On the following pages you will find

- Terminal devices
- Prosthetic gloves
- Rotation
- Elbow components
- Battery management
- Electrodes
- Control elements
- Software
- Tools



You can find our order forms in the download centre under

[www.ottobock.de/downloadcenter/](http://www.ottobock.de/downloadcenter/)

## ▶ Michelangelo hand



### Michelangelo hand

Art. no. 8E500

The Michelangelo hand features complex gripping kinematics, an attractive natural appearance and low weight. Actively driven elements are the thumb, index finger and middle finger, while the ring finger and little finger passively follow the other fingers. The thumb drive permits electronic positioning. Rotating the thumb outward creates a wide open palm, so that additional movement options are possible. This results in seven different hand positions. The Michelangelo hand can be combined with the active AxonRotation. This rotation unit assists users in numerous two-handed activities in everyday life and at work. Thanks to the flexible wrist joint mode, the various grip types of the Michelangelo hand and the active AxonRotation, compensating body movements are reduced to a minimum. The Michelangelo hand is worn with the AxonSkin prosthetic glove.

Art. no.	Side	Size	User
8E500=L-M	Left (L)	7%	Women, men
8E500=R-M	Right (R)	7%	Women, men

#### Technical data

Operating voltage	11.1 V
Operating temperature	-10 to +60°C
Storage temperature	-20 to +40°C
Relative humidity max.	80% non-condensing
Max. opening width	120 mm
Max. gripping force in Opposition Mode	70 N
Max. gripping force in Lateral Mode	60 N
Max. gripping force in Neutral Mode	15 N
Maximum speed	325 mm/sec
Weight	520 g

◉ Ordering information: The 10S500 lamination ring is included with the Michelangelo hand.

 646D501=DE  
 646D592=DE  
 646D593=DE  
 646D853=DE  
 646T3=3.4EN  
 646T3=3.6DE\_EN  
 647F472=M\_DE

 647G587



## Michelangelo hand transcarpal

Art. no. 8E550

For users with long residual limbs and a transcarpal amputation level. The numerous functions of the Michelangelo hand are also featured in this product version. The available installation space for the required technical components is very small for the Michelangelo hand transcarpal, and led to the development of a new, space-saving design concept. The compact drive unit is integrated into the palm of the hand, making the overall length without the AxonWrist very short as well. The feed-through for the Axon signal cables was adjusted accordingly, and the hand shell was adapted as well. The new lamination ring allows the O&P professional to position the hand by +/-15°.

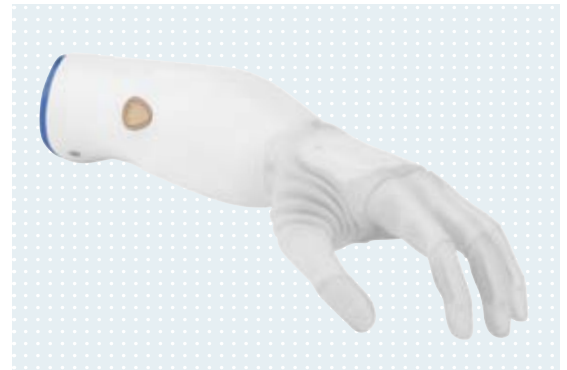

Art. no.	Side	Size	User
8E550=L -M	Left (L)	M	Women, men
8E550=R-M	Right (R)	M	Women, men

### Technical data

Operating temperature	-10 to +60°C
Max. opening width	120 mm
Max. gripping force in Opposition Mode	70 N
Max. gripping force in Lateral Mode	60 N
Max. gripping force in Neutral Mode	15 N
Maximum speed	325 mm/sec
Weight	460 g

-  646D501=DE
- 646D592=DE
- 646D593=DE
- 646D853=DE
- 646D553=DE
- 646D646=DE

• Notice: The 711M116 adapter is needed one time to put on the gloves.

• Ordering information: The 10S550 lamination ring is included with the Michelangelo hand transcarpal.

## AxonHook

Art. no. 8E600

As a complement to the Michelangelo hand (article no. 8E500), the AxonHook is designed to meet the performance needs of the most demanding users by increasing the number of functional tasks that are supported. This powerful and rugged terminal device for manual tasks ideally expands the functionality of the existing Michelangelo hand. The integrated AxonWrist allows users to easily switch between the Michelangelo hand and the AxonHook. All wrist functionality of the Michelangelo hand is implemented in the AxonHook as well. Combined with the AxonRotation or also the AxonArm Ergo for above-elbow prostheses, the AxonHook is the preferred choice for highly active prosthesis users.

Art. no.	Side
8E600=L	Left (L)
8E600=R	Right (R)

### Technical data

Max. opening width	130 mm
Max. gripping force approx.	110 N
Weight	400 g

• Notice: The AxonHook cannot be combined with the Michelangelo hand transcarpal.



## ▶ Prosthetic gloves



646D646=DE

647G596

### AxonSkin Natural

Art. no. 8S501/8S502

The AxonSkin Natural glove serves as structural protection for the Michelangelo prosthetic hand and creates a natural appearance for the patient. It is intended exclusively for use with Ottobock's Michelangelo hand. Use the 646M47 Skin Natural colour sample set to determine the colour. The Michelangelo hand is locked with the help of the mounting tool (article no. 711M64) and mounting tool (article no. 711M1) in order to apply and remove the prosthetic glove.

Art. no.	Side	Colour	User
8S501=L-M2	Left (L)	2	Men
8S501=L-M4	Left (L)	4	Men
8S501=L-M6	Left (L)	6	Men
8S501=L-M8	Left (L)	8	Men
8S501=L-M11	Left (L)	11	Men
8S501=L-M14	Left (L)	14	Men
8S501=L-M16	Left (L)	16	Men
8S501=R-M2	Right (R)	2	Men
8S501=R-M4	Right (R)	4	Men
8S501=R-M6	Right (R)	6	Men
8S501=R-M8	Right (R)	8	Men
8S501=R-M11	Right (R)	11	Men
8S501=R-M14	Right (R)	14	Men
8S501=R-M16	Right (R)	16	Men

Art. no.	Side	Colour	User
8S502=L-M2	Left (L)	2	Women
8S502=L-M4	Left (L)	4	Women
8S502=L-M6	Left (L)	6	Women
8S502=L-M8	Left (L)	8	Women
8S502=L-M11	Left (L)	11	Women
8S502=L-M14	Left (L)	14	Women
8S502=L-M16	Left (L)	16	Women
8S502=R-M2	Right (R)	2	Women
8S502=R-M4	Right (R)	4	Women
8S502=R-M6	Right (R)	6	Women
8S502=R-M8	Right (R)	8	Women
8S502=R-M11	Right (R)	11	Women
8S502=R-M14	Right (R)	14	Women
8S502=R-M16	Right (R)	16	Women

## ▶ Prosthetic gloves

### AxonSkin Visual / AxonSkin Black

Art. no. 8S500

The AxonSkin Visual and AxonSkin Black are two other versions of a PVC glove for the Michelangelo hand. The Michelangelo hand is locked with the help of the mounting tool (article no. 711M64) and mounting tool (article no. 711M1) in order to apply and remove the prosthetic glove.

Art. no.	Side	Colour
8S500=L-M0	Left (L)	Visual
8S500=R-M20	Left (L)	Black
8S500=R-M0	Right (R)	Visual
8S500=R-M20	Right (R)	Black

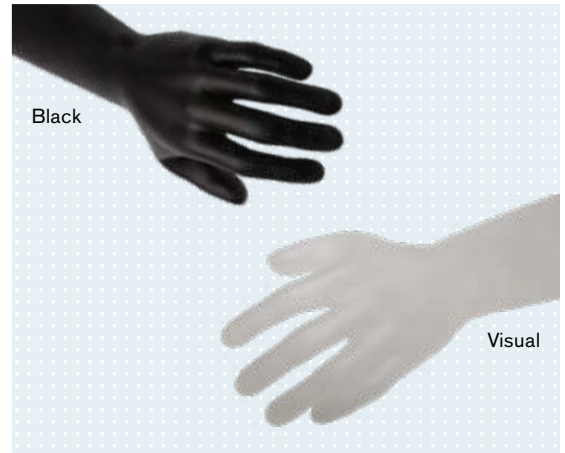

### AxonSkin Silicone

Art. no. 8S511

The first silicone glove for the Michelangelo hand. It has a highly natural appearance thanks to the hand-coloured replication of the fingernails and knuckles. The AxonSkin Silicone is very low-maintenance and barely soils, so that simple cleaning with soap and water is usually sufficient.

Art. no.	Side	Colour	User
8S511=L-M2	Left (L)	2	Men
8S511=L-M4	Left (L)	4	Men
8S511=L-M6	Left (L)	6	Men
8S511=L-M8	Left (L)	8	Men
8S511=L-M10	Left (L)	10	Men
8S511=L-M12	Left (L)	12	Men
8S511=L-M14	Left (L)	14	Men
8S511=R-M2	Right (R)	2	Men
8S511=R-M4	Right (R)	4	Men
8S511=R-M6	Right (R)	6	Men
8S511=R-M8	Right (R)	8	Men
8S511=R-M10	Right (R)	10	Men
8S511=R-M12	Right (R)	12	Men
8S511=R-M14	Right (R)	14	Men



647G861

- ⦿ Attention: Colours deviate from Skin Natural. For exact determination, please use the 646M72 colour sample ring for silicone gloves.
- ⦿ Notice: The AxonSkin Silicone cannot be combined with the Michelangelo hand transcarpal.

## ▶ Accessories



### Mounting set

Art. no. 757Z501

The mounting set (article no. 757Z501) includes various components which allow the technician to attach the AxonEnergy Integral and AxonMaster to the socket.

Please note that this article is already included in the scope of delivery of the Axon-Bus prosthetic system.



### Michelangelo socket attachment block

Art. no. 757Z504

The Michelangelo socket attachment block (article no. 757Z504) can be used for trial fittings with a ThermoLyn soft outer socket. The socket attachment block is used as an alternative to the lamination ring (article no. 10S500) and serves to secure the Michelangelo hand.



### Michelangelo hand dummy

Art. no. 757Z505

The technician can use the dummy to determine the alignment and length of the Michelangelo prosthesis while taking measurements.



### Donning spray

Art. no. 640F18

The donning spray for silicone liners and prosthetic gloves (silicone or PVC) is required among other things for donning and removal.

Art. no.	Contents
640F18	90 ml
640F18=900	900 ml (refill)



### Pump sprayer

Art. no. 640F13

The user should always keep a pump sprayer filled with special cleaner for Ottobock prosthetic gloves handy in order to be able to use the cleaner immediately in case of soiling (net contents: 90 g).

🔴 This container is empty on delivery!

## ▶ Rotation

### Special cleaner

Art. no. 640F12

In case of heavy soiling, the special cleaner for prosthetic gloves should be applied immediately (net contents: 460 g).



### AxonRotation

Art. no. 9S503

The active rotation feature is equipped with proportional control so the system is sensitive and functions exactly with the muscle signals. Proportional control is possible for both movements, rotation and the gripping function of the Michelangelo hand. Rotation assists users in numerous bimanual (two-handed) activities in everyday life and at work.

#### Technical data

Pronation/supination	160° / 160°
Idle speed	25 RPM
Max. torque	1.5 Nm
Weight	140 g



 647G648

### AxonRotation Adapter

Art. no. 9S501

The AxonRotation Adapter (article no. 9S501) in combination with an Axon-Bus terminal device such as the Michelangelo hand (article no. 8E500), facilitates a fitting with components of Ottobock's modular Axon-Bus prosthetic system. The AxonRotation Adapter (article no. 9S501) allows passive pronation/supination (360°) (weight: approx. 90 g).



 647G934

### Lamination ring

Art. no. 10S500

The lamination ring (article no. 10S500) is the connecting element between the socket and the Michelangelo hand. The technician integrates this lamination ring into the socket.

- Notice: Please note that this article is already included in the scope of delivery of the Axon-Bus prosthetic system.



### Gaiter for AxonHook

Art. no. 11D122



Not illustrated

## ▶ AxonArm Ergo



646D626=DE

647G790

### AxonArm Ergo

Art. no. 12K501

With Easy Plug, flexion aid (AFB), mechanical slip-stop function, upper arm rotation joint, adjustable friction, elbow ball made of beige plastic, forearm that can be shortened (length: 305 mm), electronic ratchetless lock.

Passive elbow component with electronic lock that adapts the proven strengths of the familiar ErgoArm (article no. 12K50) for the new Axon-Bus prosthetic system. As a result, all of the advantages of the Michelangelo hand (extraordinary functionality, natural design and trendsetting technology) are now also available to upper arm amputees.

Art. no.	Size	Colour
12K501=M	7¾	4
12K501=M-1	7¾	11
12K501=M-2	7¾	15

- The colour roughly corresponds to the glove colour according to the 646M47 colour sample set.
- The battery (article no. 757B501) is already included in the scope of delivery for the elbow.
- The cable harness (article no. 13E223) can be ordered separately!



## ▶ Battery management

### AxonEnergy Integral

Art. no. 757B501

The AxonEnergy Integral (article no. 757B501) is used exclusively to provide power to the Axon-Bus prosthetic system. The battery consists of three Li-ion cells. The integrated electronics protect the battery against short circuits, overvoltage, undervoltage and charging outside the allowable temperature range. The Axon-Bus cable with the three-pin receptacle is used to exchange data and connects the respective prosthetic components to the battery. The AxonEnergy Integral (article no. 757B501) may only be used in conjunction with components in Ottobock's Axon-Bus prosthetic system. Only the Axon-Charge Integral (article no. 757L500) may be used for charging.

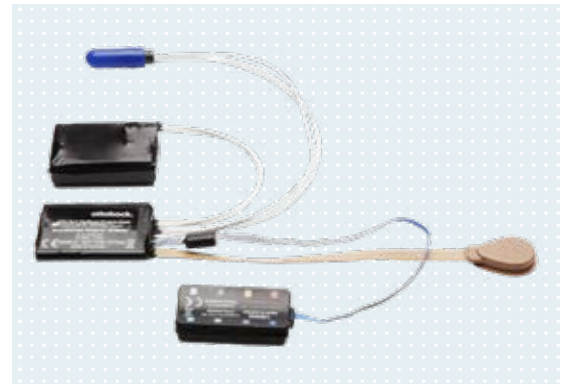

646D501=DE

647G789

#### Technical data

Operating temperature	0 to +60°C
Storage temperature	-20 to +40°C
Transport temperature	-20 to +40°C
Relative humidity max.	80% non-condensing
Capacity	1,150 mAh
Approx. output voltage	11.1 V
Approx. charging time	3.5 h
Dimensions (LxWxH)	55x35x23 mm
Weight	90 g

### Lamination dummy set

Art. no. 757Z508

The lamination dummy set (article no. 757Z508) for AxonEnergy Integral (article no. 757B501) includes dummies for lamination of the outer socket and for the charging receptacle recess. Please note that this article is already included in the scope of delivery of the Axon-Bus prosthetic system.

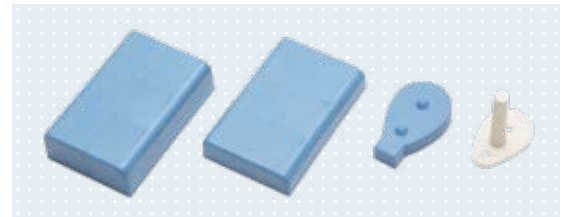

## ▶ Battery management

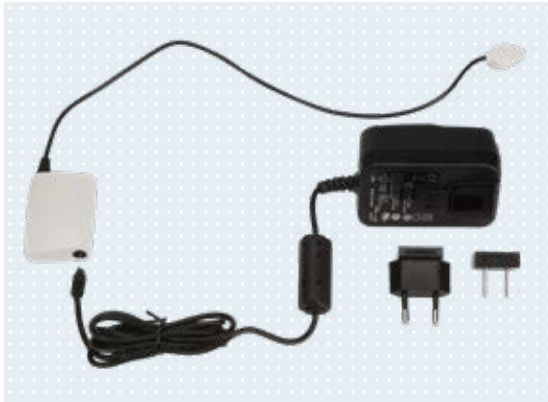

 646D501=DE

 647G593

### AxonCharge Integral

Art. no. 757L500

The AxonCharge Integral (article no. 757L500) is used to charge the AxonEnergy Integral (article no. 757B501/) of Ottobock's Axon-Bus prosthetic system. Charging is performed automatically after the charging plug has been connected to the charging receptacle of the AxonEnergy Integral (article no. 757B501). The charging plug is secured to the charging receptacle by the integrated magnet. The special contour of the charging receptacle and charging plug ensures quick, reliable positioning of the two components. LEDs indicate the readiness of the battery charger and the current battery charge level. The AxonCharge Integral (article no. 757L500) is intended solely for charging of the AxonEnergy Integral (article no. 757B501).

#### Technical data

Operating temperature	0 to +60°C
Storage temperature	-20 to +40°C
Transport temperature	-20 to +40°C
Relative humidity max.	80% non-condensing

## ▶ Electrodes and accessories

### Suction socket electrode

Art. no. 13E202

This generation of electrodes is based on the familiar 13E200 electrode. Embedded into a mounting suspension of elastic material, this electrode creates an airtight seal between the inner socket and outer socket. If used correctly, the 13E202 suction socket electrode also prevents perspiration from penetrating between the outer and inner socket, therefore effectively preventing damage to the electrical and mechanical components caused by corrosion.

The suction socket electrode can not only be used for standard sockets, but is also particularly suitable for application in elevated vacuum sockets. Combining the 12V10 suction socket electrode with a tube valve for an elevated vacuum socket creates a vacuum effect in the socket, optimising the hold of the residual limb in the socket. As with the 13E200 electrode, state-of-the-art shielding and filtering technologies also largely protect the 13E202 suction socket electrode against high frequency interference caused, for example, by mobile phones, walkie-talkies, computers or anti-theft systems in shopping centres so that the proper control of the myoelectrically controlled prosthesis is not affected.

The electrode contacts are made from pure titanium and are therefore suitable for people with allergies as well. The frequency filter's full protection effect will only be provided if the mains frequency and filter frequency are identical.

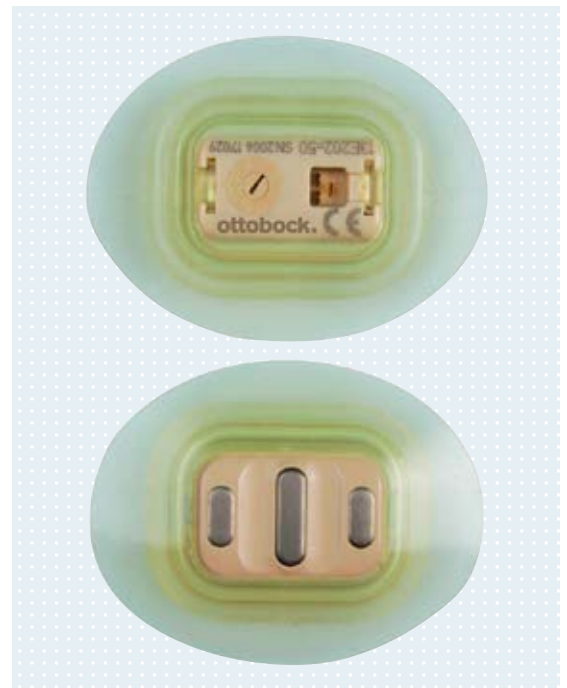

647G334

Art. no.	HZ	Frequency bandwidth	Room temperature	Operating voltage U
13E202=50	50	90–450 Hz	-15 to +60°C	4.8–7.2 V
13E202=60	60	90–450 Hz	-15 to +60°C	4.8–7.2 V

- Use silicone grease (article no. 633F11) to seal the plug connection. Remove any excess grease after connecting the electrode cable.
- Tube valve (article no. 12V10), see page 91.

### Electrode

Art. no. 13E200

These MyoBock electrodes are particularly sensitive in the range of low muscle signals. The change in amplification now takes place logarithmically, which enables enhanced differentiation of the signal level. Thanks to modern frequency shielding and filtering technologies, they are less sensitive to low and high frequency interferences that are emitted, for example, by mobile phones or shopping centre security systems. The electrode contacts are made from pure titanium and are therefore suitable for people with allergies as well. The electrode accessories for laminated inner sockets (article no. 13E153) and for vacuum-formed inner sockets (article no. 13E201) are included in the scope of delivery. The frequency filter's full protection effect will only be provided if the mains frequency and filter frequency are identical.



Art. no.	HZ	Frequency bandwidth	Room temperature	Operating voltage U
13E200=50	50	90–450 Hz	-15 to +60°C	4.8–7.2 V
13E200=60	60	90–450 Hz	-15 to +60°C	4.8–7.2 V

- Use silicone grease (article no. 633F11) to seal the plug connection. Remove any excess grease after connecting the electrode cable.

## ▶ Control elements and accessories

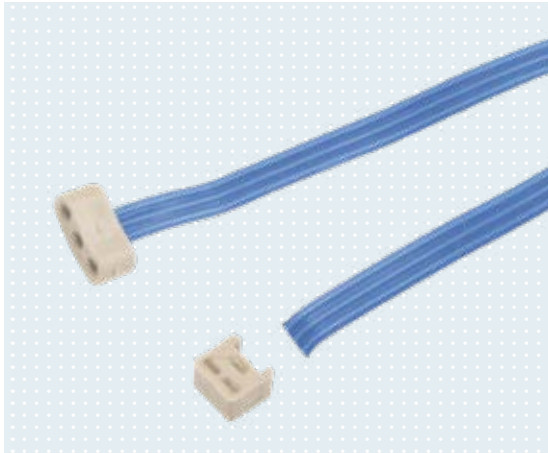

### Electrode cable with straight plug and plug connector

Art. no. 13E129=G\*

Electrode cable for connecting the electrode (article no. 13E200/13E202) or the control element (article no. 9X52, 9X53 and 9X54) with the AxonMaster (article no. 13E500) or the elbow joint (article no. 12K501).

Art. no.	Length
13E129=G100	100 mm
13E129=G300	300 mm
13E129=G600	600 mm
13E129=G1000	1,000 mm

• The plug connector (article no. 13E121) is included in the scope of delivery!

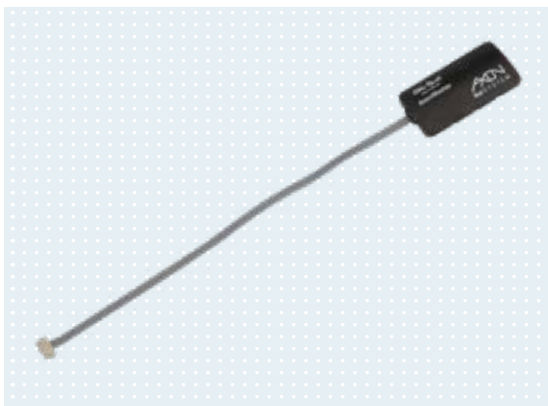

### AxonMaster

Art. no. 13E500

The AxonMaster (article no. 13E500) is the central control unit of the Axon-Bus prosthetic system. The AxonMaster samples the patient's control signals and routes them to the corresponding prosthetic components via the Axon-Bus (joint control and power supply connection).

This makes it possible to control the prosthesis and switch between the prosthetic components. In addition, the AxonMaster manages the data communication of the Axon-Bus. The AxonMaster (article no. 13E500) is intended exclusively for exoprosthetic fittings of the upper limbs and performs control and system-internal coordination of all active Ottobock Axon-Bus prosthetic components.

646D501=DE

647G590

#### Technical data

Operating temperature	0 to +60°C
Storage temperature	-20 to +40°C
Transport temperature	-20 to +40°C
Relative humidity max.	80% non-condensing
Power supply	757B501
Operating voltage	11.1 V
Dimensions (LxWxH)	53x28x9 mm
Weight	15 g

• The cable harness (article no. 13E223) can be ordered separately!



### Lamination dummy set for AxonMaster

Art. no. 757Z503

The technician uses the lamination dummy set (article no. 757Z503) to determine the optimal position of the AxonMaster.

Please note that this article is already included in the scope of delivery of the Axon-Bus prosthetic system.

## AxonSoft

Art. no. 560X500

The AxonSoft software (article no. 560X500=\*) is intended exclusively as a tool for adjusting the AxonMaster (article no. 13E500) within the framework of unilateral or bilateral prosthetic fittings with the Michelangelo hand and the Axon-Bus system components for the upper limb. The BionicLink (article no. 60X5) is the only permissible method of data transfer between the system components.

### Recommended hardware requirements for a PC with a 32-bit or 64-bit platform

- At least 1 GB free hard drive space
- Graphics card with Open GL support
- Minimum resolution: 1024 x 768 at 96 DPI (higher DPI settings can result in errors in the display, depending on the resolution)
- 32-bit colour depth (16.7 million colours)
- CD-ROM or DVD-ROM drive
- 1 available USB port (if applicable)
- Mouse and keyboard (if applicable)

### Minimum PC hardware requirements

- PC with a Pentium III/1 GHz processor, 32-bit (x86)
- 512 MB RAM (working memory)
- 1 GB free hard drive space
- Graphics card with Open GL support
- Resolution: 1024 x 768 at 96 DPI
- 32-bit colour depth (16.7 million colours)
- CD-ROM drive
- 1 available USB port (if applicable)
- Mouse and keyboard (if applicable)



646D501=DE

647G591

## BionicLink

Art. no. 60X5

The BionicLink (article no. 60X5) supports wireless data communication between Ottobock products with a Bluetooth interface (e.g. DynamicArm) and a PC with USB port or USB hub.

### The BionicLink is equipped with two LEDs

- The green LED indicates that the device is ready for use
- The blue LED indicates that a proper connection has been established between the product and the PC

A proper connection between the Ottobock product and a PC can only be established using corresponding Ottobock software products (e.g. ElbowSoft).



## ▶ Tools

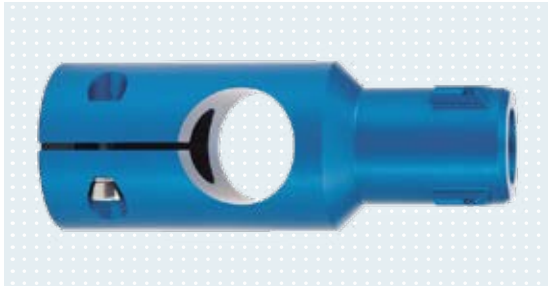

### Mounting adapter for Michelangelo

Art. no. 711M64

The mounting adapter is essential for the correct application of the AxonSkin glove in order to protect the mechanism of the Michelangelo hand and for easier handling by the technician.



### Mounting tool

Art. no. 711M1

One side with M12X1.5 exterior thread for prosthetic hands and the other side with M12X1.5 interior thread for Ottobock System Electric Hands and the Michelangelo hand.



### Mounting plate

Art. no. 711M2

The mounting plate is used to screw the mounting tool (article no. 711M1) to the workbench.



### Donning sphere

Art. no. 711M114

The donning sphere was developed especially for the Michelangelo hand and is used to briefly stretch the AxonSkin glove during donning.



### Donning tool

Art. no. 711M116

The donning tool is used for the Michelangelo hand transcarpal (article no. 8E550=\*).





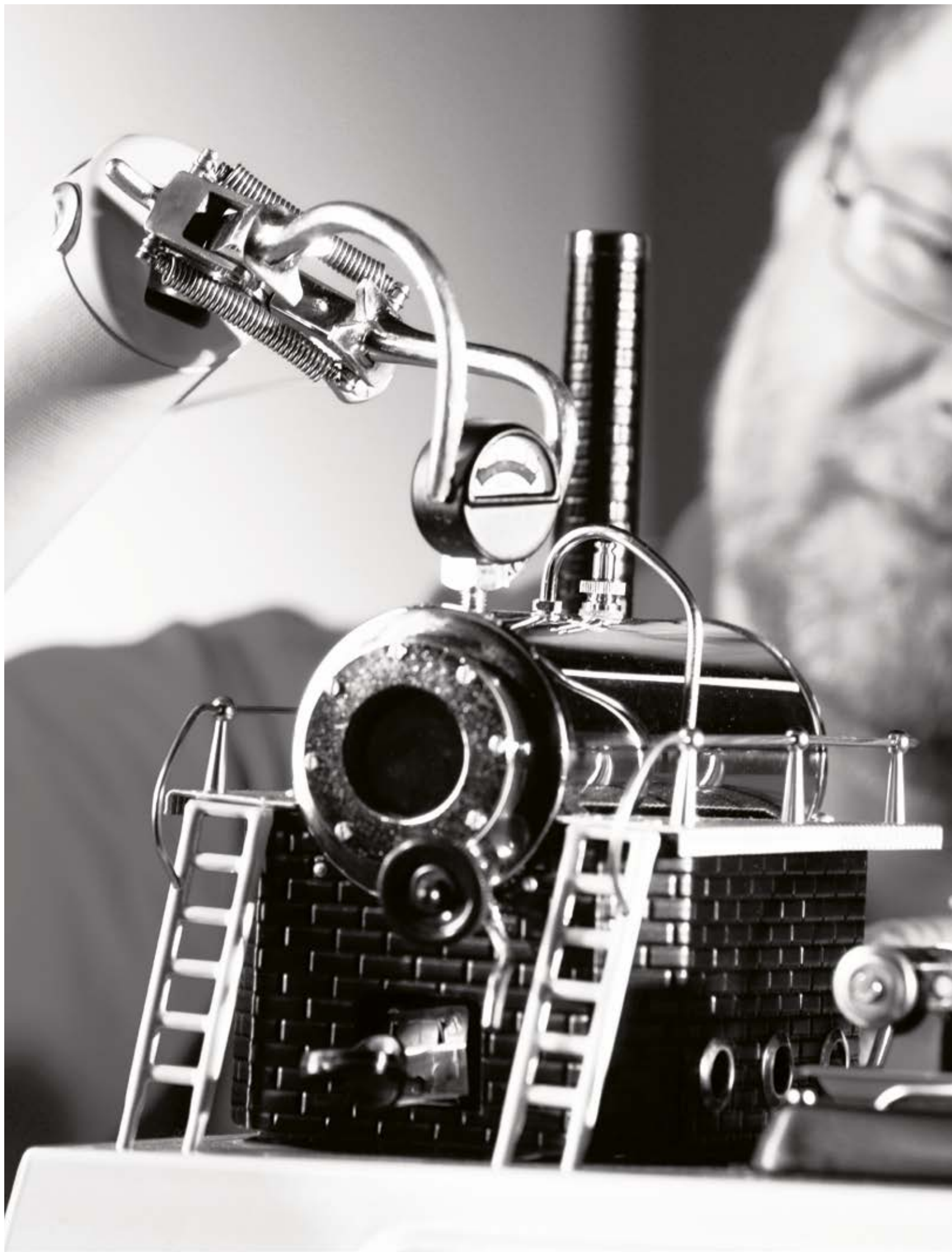



# Body-powered

## Active mechanical arm components

### Active gripping – cable-activated

The voluntary opening and voluntary closing system hands belong to the cable-controlled prostheses or “active prehensile arms” and are controlled by a body harness system. The voluntary opening system hand is opened by pulling the cable and closes automatically. The voluntary closing system hand is closed by pulling the cable. Another pull releases the lock and opens the hand. The system inner hand conceals the mechanism and serves as the shaping element for the prosthetic glove. It is selected according to the size of the inner hand and is available in various models and colours.

#### **On the following pages you will find**











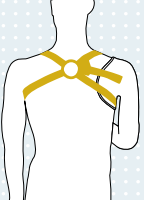

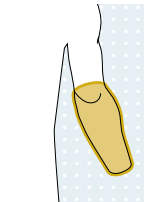



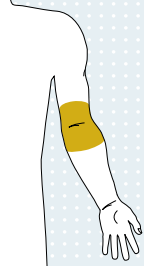







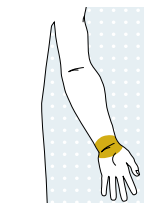

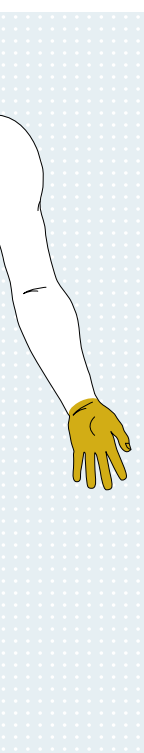

- Overview of active mechanical arm components
- Passive and active system hands
- Spare parts
- Prosthetic gloves
- Cable-activated hooks
- Terminal devices
- Wrist joints
- Elbow components
- Liners
- Upper arm and below-elbow harness



You can find our order forms  
in the download centre under

[www.ottobock.de/downloadcenter/](http://www.ottobock.de/downloadcenter/)

# Overview of active mechanical arm components

<p><b>Body harness</b></p> 	 <p><b>Triple-control above-elbow harness</b> 21A35</p>	 <p><b>Below-elbow harness</b> 21A36</p>	
<p><b>Liner</b></p> 	 <p><b>Skeo Up</b> 14Y5</p>	 <p><b>IntoLiner Acclimate</b> 14Y3</p>	
<p><b>Shoulder</b></p> 	<p>We recommend fitting patients with shoulder disarticulation or higher amputation levels with myoelectric or passive systems.</p>		
<p><b>Elbow</b></p> 	<p><b>Joint bars</b> 16X12</p> 	<p><b>Elbow components for children</b></p> <p><b>MovolinoArm</b> 12K12</p>  <p>12K19</p> 	<p><b>Elbow components for adults</b></p> <p><b>ErgoArm plus</b> 12K42</p>  <p><b>ErgoArm</b> 12K41</p>  <p>12K27</p>  <p>12K5</p>  <p>12K20</p> 
<p><b>Wrist</b></p> 	<p><b>Flexion wrist</b> 10V39 MovoWrist Flex</p> 	<p><b>Ball ratchet wrist joint</b> 10V8</p> 	<p><b>Wrist joints</b> 10V18 10V36</p>  <p><b>Ball ratchet wrist joint, short</b> 10V30</p> 
<p><b>Terminal device</b></p> 	<p><b>System hands</b></p> <p><b>Single-cable hand</b> 8K22 8K23</p> 	<p><b>Double-cable hand</b> 8K26 8K27</p> 	<p><b>Passive system hand</b> 8K18 8K19</p>  <p><b>Prosthetic Glove</b> 8S4; 8S4N 8S6; 8S6N 8S5; 8S5N 8S11; 8S11N</p> 
<p><b>Terminal devices</b></p> <p><b>All-purpose hook</b> 10A3</p> 	<p><b>All-purpose ring</b> 10A4</p> 		
<p><b>Cable-activated hooks for adolescents</b></p> <p>10A37</p> 	<p><b>Cable-activated hooks Adults</b></p> <p>10A12</p>  <p>10A71</p>  <p>10A81</p> 		

## ▶ Passive system hand

### System hand, passive

Art. no. 8K18/8K19

The passive system hand is suitable for all residual limb lengths with passive prostheses. It is opened with the sound hand and closes independently. The system is lightweight and stable. With threaded stud (article no. 8K18: M12X1.5, 8K19: 1/2"-20) and system inner hand. Available in sizes 6¾ (children), 7¼ (adolescents and women), 7¾ and 8 (men).

Art. no.	Side	Size	Inner hand	Approx. weight
8K18=L6¾	Left (L)	6¾	8X14=L6¾	185 g
8K18=L7¼	Left (L)	7¼	8X14=L7¼	250 g
8K18=L7¾	Left (L)	7¾	8X14=L7¾	280 g
8K18=L8	Left (L)	8	8X14=L8	290 g
8K18=R6¾	Right (R)	6¾	8X14=R6¾	185 g
8K18=R7¼	Right (R)	7¼	8X14=R7¼	250 g
8K18=R7¾	Right (R)	7¾	8X14=R7¾	280 g
8K18=R8	Right (R)	8	8X14=R8	290 g

Art. no.	Side	Size	Inner hand	Approx. weight
8K19=L6¾	Left (L)	6¾	8X14=L6¾	185 g
8K19=L7¼	Left (L)	7¼	8X14=L7¼	250 g
8K19=L7¾	Left (L)	7¾	8X14=L7¾	280 g
8K19=L8	Left (L)	8	8X14=L8	290 g
8K19=R6¾	Right (R)	6¾	8X14=R6¾	185 g
8K19=R7¼	Right (R)	7¼	8X14=R7¼	250 g
8K19=R7¾	Right (R)	7¾	8X14=R7¾	280 g
8K19=R8	Right (R)	8	8X14=R8	290 g

◦ The prosthetic glove must be ordered separately. See pages 171–173.



 647G444

## ▶ Active system hands



647G445

### Voluntary opening system hand

Art. no. 8K22

These system hands (metric thread) are suitable for all cable-activated prostheses. They are opened by pulling the cable (active) and close independently with concurrent locking. Available with perlon cable on the back of the hand (outer pull), with threaded stud (article no. M12x1.5) and system inner hand in the sizes 6¾ (children), 7¼ (adolescents and women), 7¾ and 8 (men).

Art. no.	Side	Size	Inner hand	Approx. weight
8K22=L6¾	Left (L)	6¾	8X14=L6¾	215 g
8K22=L7¼	Left (L)	7¼	8X14=L7¼	300 g
8K22=L7¾	Left (L)	7¾	8X14=L7¾	330 g
8K22=L8	Left (L)	8	8X14=L8	340 g
8K22=R6¾	Right (R)	6¾	8X14=R6¾	215 g
8K22=R7¼	Right (R)	7¼	8X14=R7¼	300 g
8K22=R7¾	Right (R)	7¾	8X14=R7¾	330 g
8K22=R8	Right (R)	8	8X14=R8	340 g

• The prosthetic glove must be ordered separately.



647G445

### Voluntary opening system hand

Art. no. 8K23

These system hands (inch thread) are suitable for all cable-activated prostheses. They are opened by pulling the cable (active) and close independently with concurrent locking. Available with steel cable on the back of the hand (outer pull), with threaded stud (article no. ½"-20) and system inner hand in the sizes 6¾ (children), 7¼ (adolescents and women), 7¾ and 8 (men).

Art. no.	Side	Size	Inner hand	Approx. weight
8K23=L6¾	Left (L)	6¾	8X14=L6¾	215 g
8K23=L7¼	Left (L)	7¼	8X14=L7¼	300 g
8K23=L7¾	Left (L)	7¾	8X14=L7¾	330 g
8K23=L8	Left (L)	8	8X14=L8	340 g
8K23=R6¾	Right (R)	6¾	8X14=R6¾	215 g
8K23=R7¼	Right (R)	7¼	8X14=R7¼	300 g
8K23=R7¾	Right (R)	7¾	8X14=R7¾	330 g
8K23=R8	Right (R)	8	8X14=R8	340 g

• The prosthetic glove must be ordered separately.



## ▶ Active system hands

### Voluntary closing system hand

Art. no. 8K26

These system hands close by pulling the cable – a subsequent adjustment pull increases the gripping force – and lock in any gripping position (active). Through renewed activation of the cable, the hand is released and opens independently (double cable).

Available with perlon cable on the back of the hand (outer pull), with threaded stud (article no. M12X1.5) and system inner hand in the sizes 7¼ (adolescents and women), 7¾ and 8 (men).

Art. no.	Side	Size	Inner hand	Approx. weight
8K26=L7¼	Left (L)	7¼	8X14=L7¼	340 g
8K26=L7¾	Left (L)	7¾	8X14=L7¾	370 g
8K26=L8	Left (L)	8	8X14=L8	380 g
8K26=R7¼	Right (R)	7¼	8X14=R7¼	340 g
8K26=R7¾	Right (R)	7¾	8X14=R7¾	370 g
8K26=R8	Right (R)	8	8X14=R8	380 g

◉ The prosthetic glove must be ordered separately. See pages 121–123.



647G446

### Voluntary closing system hand

Art. no. 8K27

These system hands close by pulling the cable – a subsequent adjustment pull increases the gripping force – and lock in any gripping position (active). Through renewed activation of the cable, the hand is released and opens independently (double cable).

Available with steel cable on the back of the hand (outer pull), with threaded stud (½"-20) and system inner hand in sizes 7¼ (adolescents and women), 7¾ and 8 (men).

Art. no.	Side	Size	Inner hand	Approx. weight
8K27=L7¼	Left (L)	7¼	8X14=L7¼	340 g
8K27=L7¾	Left (L)	7¾	8X14=L7¾	370 g
8K27=L8	Left (L)	8	8X14=L8	380 g
8K27=R7¼	Right (R)	7¼	8X14=R7¼	340 g
8K27=R7¾	Right (R)	7¾	8X14=R7¾	370 g
8K27=R8	Right (R)	8	8X14=R8	380 g

◉ The prosthetic glove must be ordered separately.



647G446

## ▶ Spare parts and accessories



### System inner hand

Art. no. 8X14

System inner hand with support for small and ring finger as well as retainer ring (article no. 9S187).

Art. no.	Side	Size
8X14=L6¾	Left (L)	6¾
8X14=L7¼	Left (L)	7¼
8X14=L7¾	Left (L)	7¾
8X14=L8	Left (L)	8
8X14=R6¾	Right (R)	6¾
8X14=R7¼	Right (R)	7¼
8X14=R7¾	Right (R)	7¾
8X14=R8	Right (R)	8

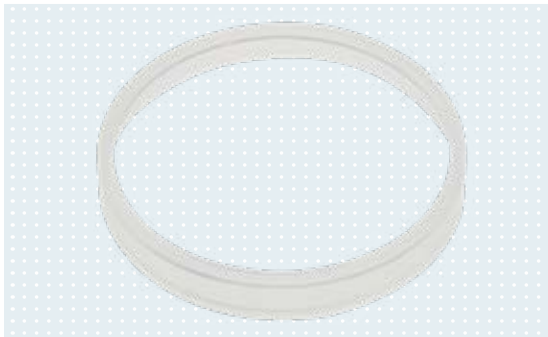

### Lock ring

Art. no. 9S187

Wide lock ring. Compatible with the system inner hand (article no. 8X14) in hand sizes 7¼, 7¾ and 8.

Art. no.	Size
9S187=7¼	7¼
9S187=7¾	7¾
9S187=8¼	8¼

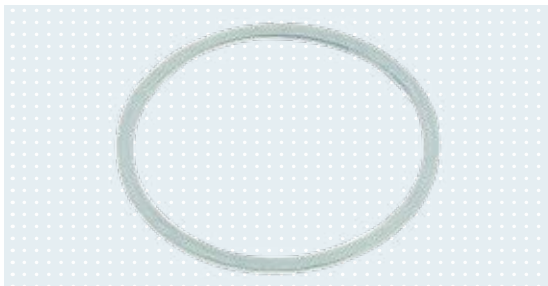

### Retainer ring

Art. no. 9S15=42

Retainer ring to secure the system inner hand (article no. 8X14) in size 6¾.



### Suspension rosette

Art. no. 21A8

## ▶ Spare parts and accessories

### Chassis with threaded stud

Article no. 9S\*

Art. no.	Diameter	Threaded stud	Compatible with
9S10=40	40 mm	M12X1.5	8K18=L/R 6¼ 8K22=L/R 6¾ 8K26=L/R 6¾
9S166=44-N	44 mm	M12X1.5	8K18=L/R 7¼ 8K22=L/R 7¼ 8K26=L/R 7¼
9S166=48-N	48 mm	M12X1.5	8K18=L/R 7¾ 8K18=L/R 8 8K22=L/R 7¾ 8K22=L/R 8 8K26=L/R 7¾ 8K26=L/R 8
9S52=40	40 mm	½"-20	8K19=L/R 6¾ 8K23=L/R 6¾ 8K27=L/R 6¾
9S185=44-N	44 mm	½"-20	8K19=L/R 7¼ 8K23=L/R 7¼ 8K27=L/R 7¼
9S185=48-N	48 mm	½"-20	8K19=L/R 7¾ 8K19=L/R 8 8K23=L/R 7¾ 8K23=L/R 8 8K27=L/R 7¾ 8K27=L/R 8 8K29=L/R 7¾ 8K29=L/R 8



### Finger and thumb cover

Art. no. 9S6

Finger and thumb cover compatible with hand sizes 6¾, 7¼, 7¾ and 8.



### Lamination ring

Art. no. 9E94

Lamination ring available for hand sizes 6¾, 7¼, 7¾ and 8.

Art. no.	Diameter	Size
9E94=44	44 mm	6¾
9E94=50	50 mm	7¼, 7¾ and 8



## ▶ Spare parts and accessories

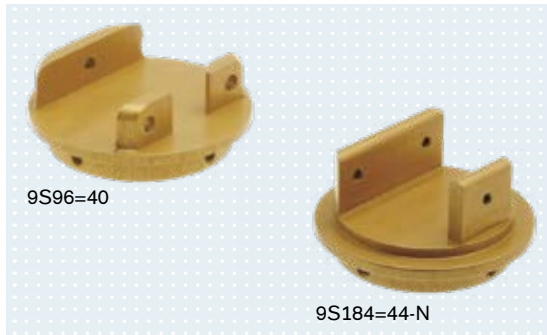

### Chassis

Art. no. 9S96/9S184

Chassis for excessively long forearm and wrist disarticulation residual limbs. Compatible with lamination ring (article no. 9E94).

Art. no.	Diameter	Size
9S96=40	40 mm	6¾
9S184=44-N	44 mm	7¼
9S184=48-N	48 mm	7¾ and 8

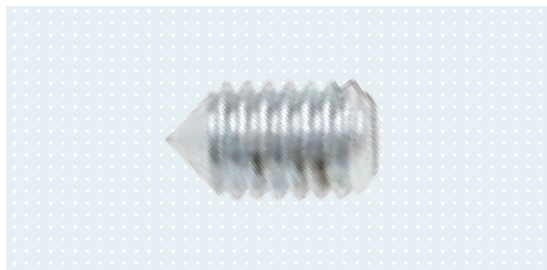

### Set screw

Art. no. 506G4

Set screw for chassis. Four set screws are required per chassis.

Art. no.	Compatible with
506G4=M3X5	Chassis article no. 9S96=40
506G4=M4X5	Chassis article no. 9S184



### Flange button head socket screw

Art. no. 501T52=M3X6

The M3X6-threaded flange button head socket screw is used to bolt the chassis to the system hand base (all sizes). Two pieces are required.



### Flange button head socket screw

Art. no. 501T52=M3X8

The M3X8-threaded flange button head socket screw is used to bolt the chassis to the system hand cover plate (all sizes). One screw is required.

# ▶ Prosthetic gloves

## Prosthetic glove for children

Art. no. 8S6=170X65

The prosthetic glove for children is available in size 6¾ und in 18 colours.

In addition to the standard prosthetic glove, Ottobock also offers additional models of the Skin Natural series. The multilayer structure of the gloves gives them a depth effect so that they have a very vivid appearance. The outer translucent layer allows the coloured fibres of the material to shine through. This simulates the natural vein structure of human skin. Please add an N before the = in the article number.

### Example

- 8S6=170X65L (standard glove)
- 8S6N=170X65L (Skin Natural)

Art. no.	Side	Size	Sleeve length
8S6=170X65L	Left (L)	6¾	300 mm
8S6=170X65R	Right (R)	6¾	300 mm

- The entire Skin Natural colour palette is produced with seven colours. The new 646M47 colour scale helps when selecting the right sample.

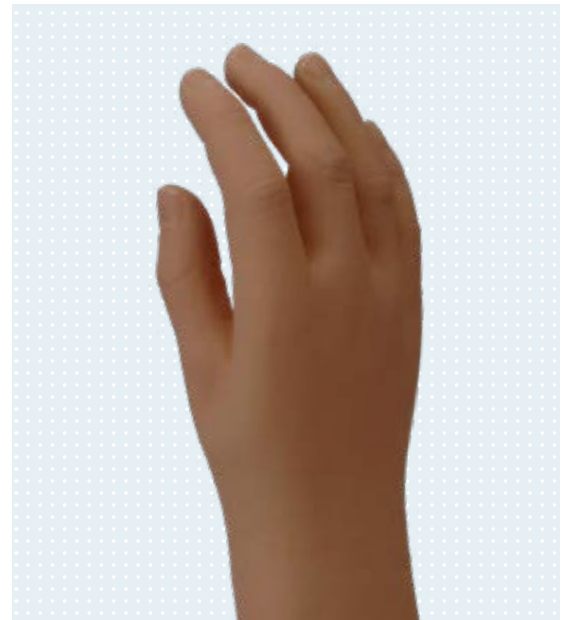

647G468 (standard glove)  
647G571 (Skin Natural)

## Prosthetic glove for adolescents

Art. no. 8S4=190X76

The prosthetic glove for adolescents is available in size 7¼ und in 18 colours.

In addition to the standard prosthetic glove, Ottobock also offers additional models of the Skin Natural series. The multilayer structure of the gloves gives them a depth effect so that they have a very vivid appearance. The outer translucent layer allows the coloured fibres of the material to shine through. This simulates the natural vein structure of human skin. Please add an N before the = in the article number.

### Example

- 8S4=190X76L (standard glove)
- 8S4N=190X76L (Skin Natural)

Art. no.	Side	Size	Sleeve length
8S4=190X76L	Left (L)	7¼	215 mm
8S4=190X76R	Right (R)	7¼	215 mm

- The entire Skin Natural colour palette is produced with seven colours. The new 646M47 colour scale helps when selecting the right sample.



647G468 (standard glove)  
647G571 (Skin Natural)

## ▶ Prosthetic gloves



📄 647G468 (standard glove)  
647G571 (Skin Natural)

### Prosthetic glove for men

Art. no. 8S11=210X78

The prosthetic glove for men is available in size 7¾ und in 18 colours.

In addition to the standard prosthetic glove, Ottobock also offers additional models of the Skin Natural series. The multilayer structure of the gloves gives them a depth effect so that they have a very vivid appearance. The outer translucent layer allows the coloured fibres of the material to shine through. This simulates the natural vein structure of human skin.

Please add an N before the = in the article number.

#### Example

- 8S11=210X78L (standard glove)
- 8S11N=210X78L (Skin Natural)

Art. no.	Side	Size	Sleeve length
8S11=210X78L	Left (L)	7¾	320 mm
8S11=210X78R	Right (R)	7¾	320 mm

- ◉ The entire Skin Natural colour palette is produced with seven colours. The new 646M47 colour scale helps when selecting the right sample.



📄 647G468 (standard glove)  
647G571 (Skin Natural)

### Prosthetic glove for men

Art. no. 8S4=220X80

The prosthetic glove for men is available in size 8 und in 18 colours.

In addition to the standard prosthetic glove, Ottobock also offers additional models of the Skin Natural series. The multilayer structure of the gloves gives them a depth effect so that they have a very vivid appearance. The outer translucent layer allows the coloured fibres of the material to shine through. This simulates the natural vein structure of human skin.

Please add an N before the = in the article number.

#### Example

- 8S4=220X80L (standard glove)
- 8S4N=220X80L (Skin Natural)

Art. no.	Side	Size	Sleeve length
8S4=220X80L	Left (L)	8	225 mm
8S4=220X80R	Right (R)	8	225 mm

- ◉ The entire Skin Natural colour palette is produced with seven colours. The new 646M47 colour scale helps when selecting the right sample.

- ◉ Special cleaner for prosthetic gloves is found on page 234.



## ▶ Prosthetic gloves

### Prosthetic glove for women

Art. no. 8S5=195X78

The prosthetic glove for women is available in size 7¼ und in 18 colours.

In addition to the standard prosthetic glove, Ottobock also offers additional models of the Skin Natural series. The multilayer structure of the gloves gives them a depth effect so that they have a very vivid appearance. The outer translucent layer allows the coloured fibres of the material to shine through. This simulates the natural vein structure of human skin. Please add an N before the = in the article number.

#### Example

- 8S5=195X78L (standard glove)
- 8S5N=195X78L (Skin Natural)

Art. no.	Side	Size	Sleeve length
8S5=195X78L	Left (L)	7¼	340 mm
8S5=195X78R	Right (R)	7¼	340 mm

- The entire Skin Natural colour palette is produced with seven colours. The new 646M47 colour scale helps when selecting the right sample.



- 647G468 (standard glove)
- 647G571 (Skin Natural)

- Special cleaner for prosthetic gloves is found on page 234.

## ▶ Cable-activated hooks and accessories

### Easy to open, simple to close

In cable-controlled prostheses, a cable-activated hook can be used as the terminal device instead of a system hand. It is opened by pulling a control cable and is closed automatically by spring or rubber elements. Apart from the cable-activated

hooks for adolescents, there are also standard hooks for adults and all-purpose hooks. The various connecting elements for attaching the cable-activated hooks to the wrist construction are described at the end of this section.



647G443

### Cable-activated hook for adolescents

Art. no. 10A37

Cable-activated hook for adolescents with threaded stud made of light metal.

Art. no.	Side	Threaded stud
10A37=LM12X1.5	Left (L)	M12X1.5
10A37=L½"-20	Left (L)	½"-20
10A37=RM12X1.5	Right (R)	M12X1.5
10A37=R½"-20	Right (R)	½"-20

▶ Connecting elements for cable-activated hooks are listed on page 138.

## ▶ Cable-activated hooks and accessories

### MovoHook 2Grip

Art. no. 10A71

Especially where metal is very slippery on certain materials, the coating of the hook tips provides a very secure grip. However, the coating does not adhere to textiles so sliding through a sleeve while getting dressed or undressed does not pose a problem. The 10A71 MovoHook 2Grip is made of food grade aluminium (weight: 120 g), has a hook tip coating for improved grip and an opening width of 100 mm. Chemical resistance can be tested on request in individual cases. With the MovoHook 2Grip, there is no need for finger covers.

Art. no.	Side	Threaded stud
10A71=LM12X1.5	Left (L)	M12X1.5
10A71=L½"-20	Left (L)	½"-20
10A71=RM12X1.5	Right (R)	M12X1.5
10A71=R½"-20	Right (R)	½"-20

◉ Connecting elements for cable-activated hooks are listed on page 139.



647G204

### MovoHook 2Grip

Art. no. 10A81

Especially where metal is very slippery on certain materials, the coating of the hook tips provides a very secure grip. However, the coating does not adhere to textiles so sliding through a sleeve while getting dressed or undressed does not pose a problem. The 10A81 MovoHook 2Grip is made of stainless, food grade steel (weight: 250 g), has a hook tip coating for improved grip and an opening width of 100 mm. Chemical resistance can be tested on request in individual cases. With the MovoHook 2Grip, there is no need for finger covers.

Art. no.	Side	Threaded stud
10A81=LM12X1.5	Left (L)	M12X1.5
10A81=L½"-20	Left (L)	½"-20
10A81=RM12X1.5	Right (R)	M12X1.5
10A81=R½"-20	Right (R)	½"-20

◉ Connecting elements for cable-activated hooks are listed on page 139.



647G204

## ▶ Cable-activated hooks and accessories



647G442

### Cable-activated hook for adults

Art. no. 10A12

The all-purpose hook is made of stainless steel.

Art. no.	Side	Threaded stud
10A12=LM12X1.5	Left (L)	M12X1.5
10A12=L½"-20	Left (L)	½"-20
10A12=RM12X1.5	Right (R)	M12X1.5
10A12=R½"-20	Right (R)	½"-20

◦ Connecting elements for cable-activated hooks are listed on page 139.



### Finger cover

Art. no. 10Y1

Plastic finger cover in colour 4 (beige). Accessories for 10A37 cable-activated hook.



### Double spring

Art. no. 10Y2

Double spring as spare part for 10A11, 10A18 and 10A60 cable-activated hooks. 2 pieces are required to completely renew all springs.



### Rubber band

Art. no. 10Y13

## ▶ Cable-activated hooks and accessories

### Spring

Art. no. 10Y12

The spring is required for the all-purpose hook (article no. 10A12). To replace all springs, 3 pieces are required.

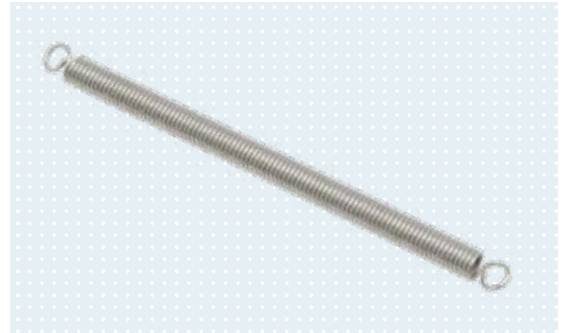

### Spring set

Art. no. 10A101

Replacement spring set as spare part for the MovoHook 2Grip cable-activated hooks article no. 10A71/10A81. The set includes both springs, including adapters. The pull of the springs is identical to that of the factory default.

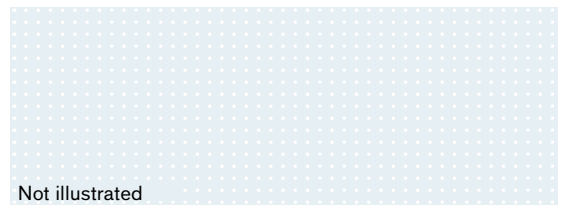

### Connection piece for cable-activated hook

Art. no. 21A13

Connection piece for the cable-activated hook with the connection piece screw (article no. 21A9) and the spacer washer (article no. 21A10) or with the ball-shaft adapter (article no. 10Y31=1). Material: perlon cable.

Art. no.	Compatible with
21A13=3	10Y32, hook 10A11, 10A12, 10A60
21A13=4	10Y32, hook 10A71, 10A81

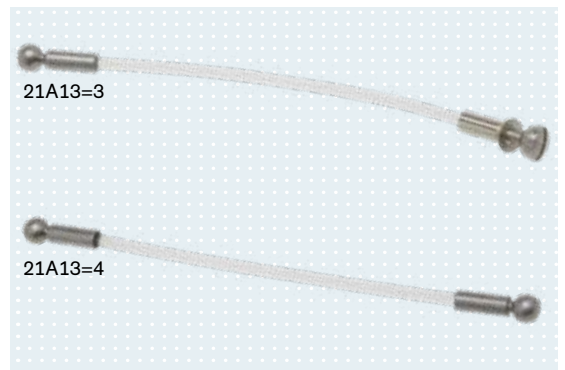

### Connection piece for hook

Art. no. 21A44

Connection piece for hook with suspension rosette (article no. 21A8) and ball-shaft adapter (article no. 10Y31=1). Compatible with the models article no. 10A12, 10A18, 10A25 and 10A37 in connection with the body harnesses article no. 21A35/21A36=\*. Material: perlon cable.

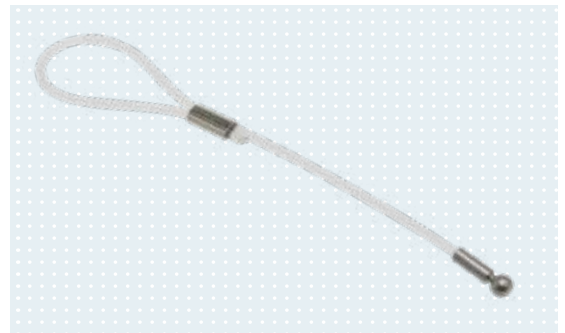

## ▶ Cable-activated hooks and accessories

---

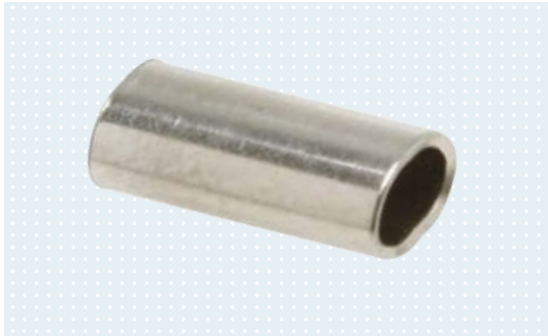

Suspension rosette

Art. no. 21A8



Connection piece screw

Art. no. 21A9



Spacer washer

Art. no. 21A10





## ▶ Terminal devices

### All-purpose hook

Art. no. 10A3

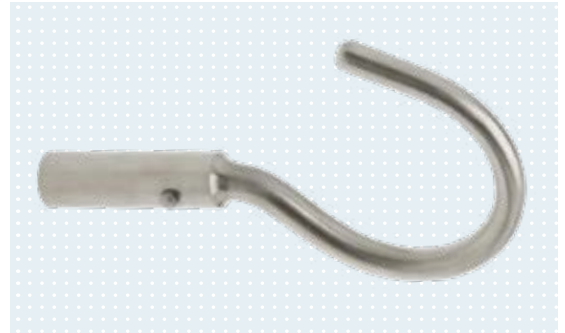
Nickel-plated all-purpose hook with standard stud.



 647G455

### All-purpose ring

Art. no. 10A4

Nickel-plated all-purpose ring with standard stud.



 647G455

## ▶ Wrist joints and accessories



647G375

### MovoWrist Flex

Art. no. 10V39

The MovoWrist Flex wrist enables the flexion and extension of a cable-activated or passive terminal device and locking with 5 locking positions from  $-15^\circ$  to  $+45^\circ$  as well as  $360^\circ$  rotation with 20 different positions. Overall length: 33 mm, of which 12 mm are visible on the distal end.

Art. no.	Exterior diameter
10V39=45	45 mm
10V39=50	50 mm



### Adapter

Art. no. 10A30

Adapter to connect a terminal device to the MovoWrist Flex wrist joint.

Art. no.	Compatible with
10A30=M12X1.5	Terminal device with metric thread
10A30=1/2"-20	Terminal device with inch thread



### Lamination ring

Art. no. 11D1

Lamination ring for MovoWrist Flex wrist joint. Please note the correct diameter of the joint when placing your order.

Art. no.	Diameter
11D1=45	45 mm
11D1=50	50 mm

## ▶ Wrist joints and accessories

### Ottobock wrist joint

Art. no. 10V18

Ottobock wrist joint (metric thread) with interior thread and cylindrical lamination ring. Thread: M12X1.5.

Art. no.	Exterior diameter
10V18=34	34 mm
10V18=40	40 mm
10V18=45	45 mm
10V18=50	50 mm



647G453

### Ottobock wrist joint

Art. no. 10V36

Ottobock wrist joint (inch thread) with interior thread and cylindrical lamination ring. Thread: 1/2"-20.

Art. no.	Exterior diameter
10V36=34	34 mm
10V36=45	45 mm
10V36=50	50 mm



647G453

### Cylindrical lamination ring

Art. no. 11D20

Art. no.	Exterior diameter	Compatible with
11D20=34	34 mm	Art. no. 10V18=34
11D20=40	40 mm	Art. no. 10V18=40
11D20=45	45 mm	Art. no. 10V18=45
11D20=50	50 mm	Art. no. 10V8, 10V9, 10V10, 10V18=50, 10V36=50



### Oval head screw (sheet metal screw)

Art. no. 501S40

Oval head screw as spare part for the cylindrical lamination ring article no. 11D20 for the wrist joints article no. 10V18 and 10V36.

Art. no.	Lamination ring diameter
501S40=3.5X9.5	28 and 34 mm
501S40=3.5X13	40, 45 and 50 mm



## ▶ Wrist joints and accessories



### Rubber friction ring

Art. no. 11D27

Spare part for the Ottobock wrist joints article no. 10V18 and 10V36.

Art. no.	Lamination ring diameter	Diameter
11D27=25	28 mm	25 mm
11D27=32	34, 40, 45 and 50 mm	32 mm



### Ball ratchet wrist joint

Art. no. 10V8

The ball ratchet wrist joint with locking lever is used to connect a hand or a hook to an attachment plate with stud (article no. 10A43). The joint body has a diameter of 50 mm.

Art. no.	Weight	Overall length
10V8	120 g (0.26 lbs)	25 mm

647G451



### Ball ratchet wrist joint, short

Art. no. 10V30

The short ball ratchet wrist joint with locking lever can be used for fittings for long below-elbow residual limbs. To connect with a hand or a hook, an attachment plate with a short stud (article no. 10A56) must be used. The joint body has a diameter of 50 mm.

Art. no.	Weight	Overall length
10V30	100 g	19 mm

647G451



### Standard connector

Art. no. 10V15

Standard connector for accommodating terminal devices with a standard stud (diameter: 13 mm) and for connecting to ball ratchet or ratchetless wrist joints. With attachment plate and stud.

647G455

## ▶ Wrist joints and accessories

### Quick-disconnect wrist unit with standard connector

Art. no. 11S33

Quick-disconnect wrist unit with standard connector for accommodating terminal devices with a standard stud (diameter: 13 mm) and for attachment to the Ottobock system wrist joint.

Art. no.	Exterior diameter
11S33=40	40 mm
11S33=44	44 mm
11S33=48	48 mm

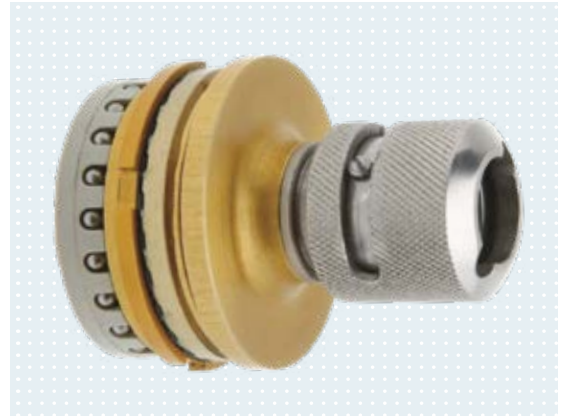

647G455

### Attachment plate with stud

Art. no. 10A43

Attachment plate with stud to connect a cable-activated hook or a system hand to the wrist joint article no. 10V8. Made of stainless steel with a diameter of 50 mm and an interior thread.

Art. no.	Interior thread
10A43=M12X1.5	M12X1.5
10A43=½"-20	½"-20



### Attachment plate with short stud

Art. no. 10A56

Attachment plate with short stud to connect a cable-activated hook or a system hand to the wrist joint article no. 10V30. Made of stainless steel with a diameter of 50 mm and an interior thread.

Art. no.	Interior thread
10A56=M12X1.5	M12X1.5
10A56=½"-20	½"-20



### Oval countersunk head screw, slotted

Art. no. 501S27=M3X8

The oval countersunk head screw, slotted, made of stainless steel is compatible with art. no. 10V8, 10V9, 10V10 and 10V25. The M4 thread with a head diameter of 7.2 mm has a thread length of 8 mm.



## ▶ Elbow components and accessories



647H437

### ErgoArm plus

Art. no. 12K42

Elbow for cable-controlled prostheses. With internal ratchetless lock, AFB (Automatic Forearm Balance) and upper arm rotation joint (humeral rotation feature), with adjustable friction, plastic forearm shell, elbow ball made of beige plastic, length: 305 mm, circumference: 250 mm. The slip-stop function allows a controlled lowering of the forearm, without having to release and engage the lock completely. The lock can bear a load of up to 230 N at a forearm length of approximately 305 mm. The internal ratchetless lock can be unlocked or locked in any position, even under a load. The AFB flexion aid supports the flexion of the joint and allows for natural free-swing behaviour.

Art. no.	Size	Upper arm connection diameter	Lamination ring diameter	Colour
12K42=45	6¾ – 7¼	70 mm	45 mm	4
12K42=45-7	6¾ – 7¼	70 mm	45 mm	Black
12K42=50	7¾ – 8¼	70 mm	50 mm	4
12K42=50-1	7¾ – 8¼	70 mm	50 mm	11
12K42=50-2	7¾ – 8¼	70 mm	50 mm	15
12K42=50-7	7¾ – 8¼	70 mm	50 mm	Black

- The colours roughly correspond to the glove colours according to the 646M3 colour sample set.
- ErgoArm is available in black from 1<sup>st</sup> of July 2019.

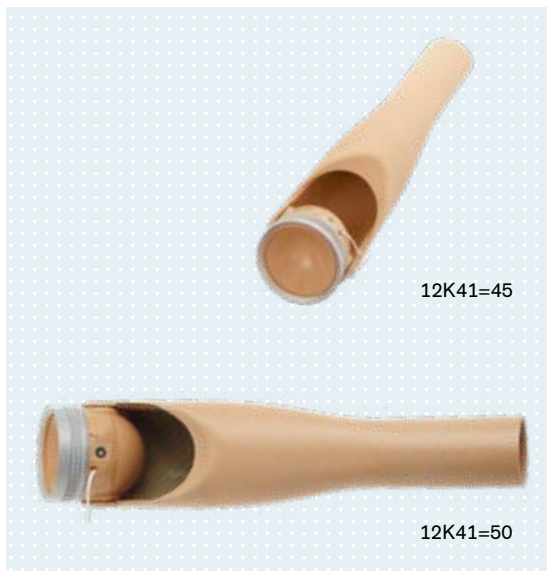

647H438

### ErgoArm

Art. no. 12K41

Elbow for cable-controlled prostheses. With internal ratchetless lock, upper arm rotation joint (humeral rotation feature), with adjustable friction, plastic forearm shell, elbow ball made of beige plastic, length: 305 mm, circumference: 250 mm. The slip-stop function makes it possible to lower the forearm in a controlled manner without having to fully release and reactivate the lock. The lock can bear a load of up to 230 N at a forearm length of approximately 305 mm. The internal ratchetless lock can be unlocked or locked in any position, even under a load.

Art. no.	Size	Upper arm connection diameter	Lamination ring diameter	Colour
12K41=45	6¾ – 7¼	70 mm	45 mm	4
12K41=50	7¾ – 8¼	70 mm	50 mm	4
12K41=50-1	7¾ – 8¼	70 mm	50 mm	11
12K41=50-2	7¾ – 8¼	70 mm	50 mm	15

- The colours roughly correspond to the glove colours according to the 646M3 colour sample set.



# ▶ Elbow components and accessories

## Forearm

Art. no. 12K48

Art. no.	Colour	Diameter	Compatible with
12K48=45	4	45 mm	12K42/44/50=45
12K48=45-7	Black	45 mm	12K42/44/50=45
12K48=50	4	50 mm	12K42/44/50=50
12K48=50-1	11	50 mm	12K42/44/50=50
12K48=50-2	15	50 mm	12K42/44/50=50
12K48=50-7	Black	50 mm	12K42/44/50=50

◉ 12K48 available in black from 1 June 2019.

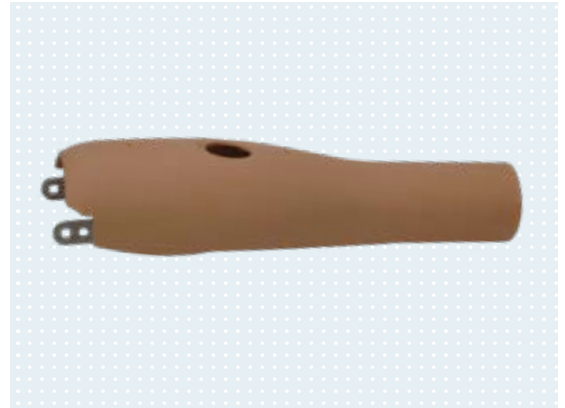

## Forearm

Art. no. 12K49

Art. no.	Colour	Diameter	Compatible with
12K49=45	4	45 mm	12K41=45
12K49=50	4	50 mm	12K41=50
12K49=50-1	11	50 mm	12K41=50
12K49=50-2	15	50 mm	12K41=50

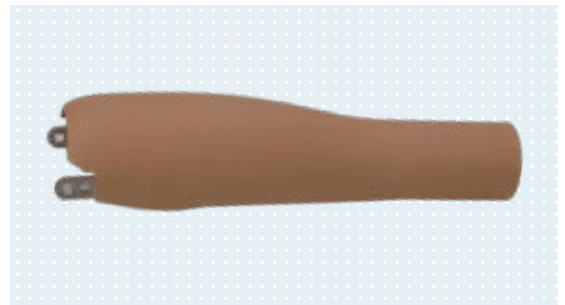

## Elbow joint

Art. no. 12A13

Art. no.	Colour
12A13	4
12A13-1	11
12A13-7	Black
12A13-15	15

◉ 12A13-7 is available from 1 June 2019.



## Clamp plate

Art. no. 13G68

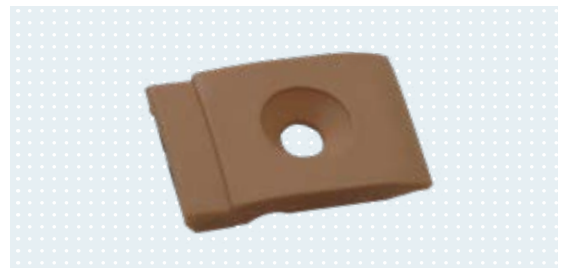

## ▶ Elbow components and accessories



### Lamination ring

Art. no. 13Z47



### Ball cap

Art. no. 13Z48

Art. no.	Colour
13Z48	4
13Z48-1	11
13Z48-2	15
13Z48-7	Black

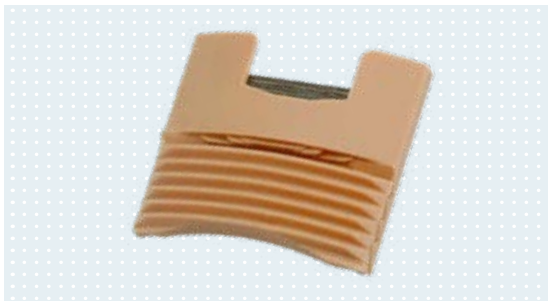

### Thread segment

Art. no. 13Z50



### Hole covering

Art. no. 13Z51

## ▶ Elbow components and accessories

### Spring telescope

Art. no. 13Z52



### Switch cable

Art. no. 13Z53

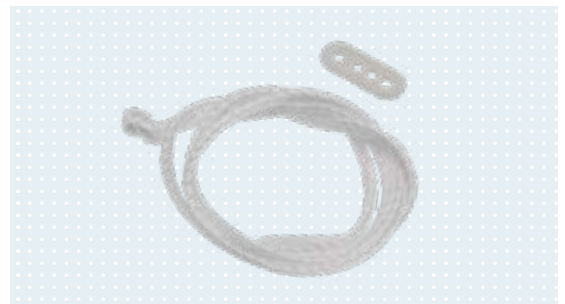

### Lamination protection cover

Art. no. 13Z55



### Bracket cover

Art. no. 13Z56

Art. no.	Colour
13Z56	4
13Z56-1	11
13Z56-2	15
13Z56-7	Black

● 13Z56-7 is available from 1 June 2019.



## ▶ Elbow components and accessories

---



Pressure piece

Art. no. 13Z57



Eccentric

Art. no. 13Z58



Countersunk head screw

Art. no. 501S84=M4X20



Countersunk head screw

Art. no. 501S101=M4X12

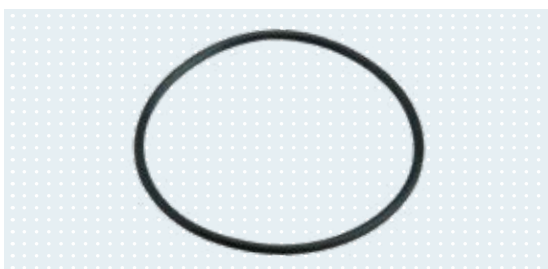

O-ring

Art. no. 627F13=60X2.5

## ▶ Elbow components and accessories

### Alignment aid for ErgoArm

Art. no. 743A23

The alignment and foaming aid allows the alignment of an interim prosthesis for functional training in the rehabilitation phase.

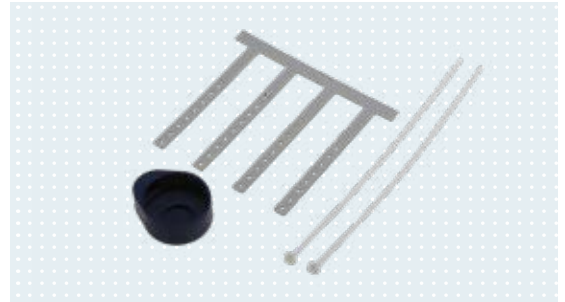

### Alignment tool for DynamicArm

Art. no. 743A27

Alignment and foaming aid allows the alignment of an interim prosthesis for functional training in the rehabilitation phase.

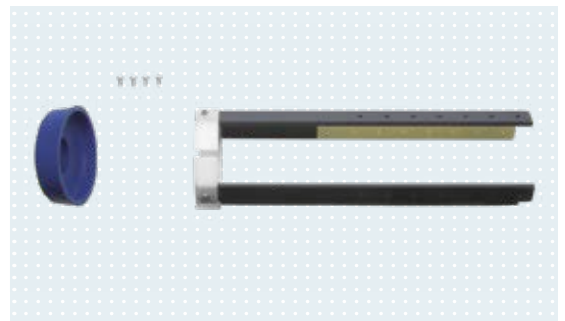

### Clamp stopple set

Art. no. 21A207

The set allows for the connection of an ErgoArm forearm (article no. 12K48=\* or 12K49=\*) to the flexion cable of a triple-control above-elbow harness (article no. 21A35=1).

#### Consisting of

- Clamp stopple (10 pieces)
- Threaded nut, short (10 pieces)
- Twist drill, diameter: 5.5 mm (1 piece)

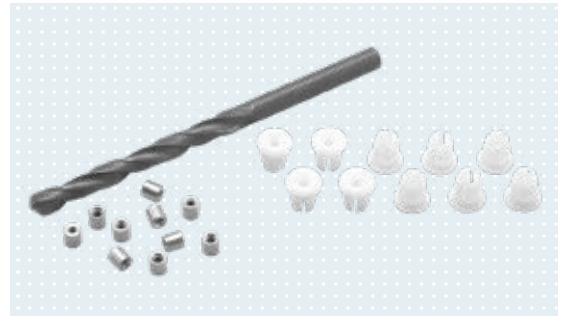

### Adapter

Art. no. 13Z68

The adapter is used to install an Ottobock elbow component (article no. 12K50) to a Hosmer lamination ring.



## ▶ Elbow components and accessories



647G470

### Elbow component with cable lock

Art. no. 12K27

Thanks to the exterior joint construction and special technology for interior and exterior rotation of the forearm, this joint allows the distal residual limb to reach up to the joint ball. As a result, it is suitable for all residual limb lengths including elbow disarticulation. With single-sided, rotatable cable lock (18 locking positions in approx. 7.2° increments) and upper arm rotation joint (humeral rotation feature) with lamination ring. The beige elbow component made of plastic has a length of 270 mm or 300 mm and a circumference of 260 or 300 mm. The elbow ball is made of beige plastic (corresponds to skin colour 4).

Art. no.	Size	Upper arm connection diameter	Lamination ring diameter	Medial joint diameter
12K27=58X45	6¾ – 7¼	70 mm	45 mm	58 mm
12K27=58X50	7¾ – 8	70 mm	50 mm	58 mm
12K27=78X45	6¾ – 7¼	90 mm	45 mm	78 mm
12K27=78X50	7¾ – 8	90 mm	50 mm	78 mm



### Pull cable

Art. no. 16Y26

The pull cable with screw connection is a spare part for the elbow component article no. 12K27 and the elbow joint bars article no. 16X12 and 16X13.

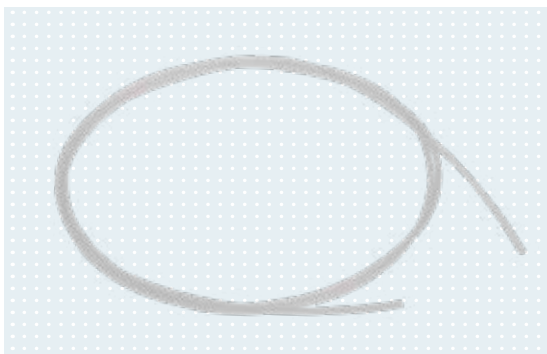

### Perlon cable

Art. no. 21A18

Perlon cable with a diameter of 2 mm.

Art. no.	Length	Order by
21A18=2X1	1 m	linear metres
21A18=2X5	5 m	linear metres
21A18=2X10	10 m	linear metres
21A18=2X25	25 m	linear metres



### Lamination ring

Art. no. 13G8=67

Lamination ring with an exterior diameter of 67 mm. Compatible with the elbow components article no. 12K5 and 12K20 as well as for the modular kit article no. 12R6.



## ▶ Elbow components and accessories

### Elbow component with passive lock

Art. no. 12K5

Elbow component with manual elbow locking (13 locking positions in approx. 8° increments) and upper arm rotation joint (humeral rotation feature). The plastic forearm shell has a length of approx. 260 mm and a circumference of approx. 245 mm. It is made of beige plastic (corresponds to skin colour 4). It has an opening for the 9E185=50-1 extension cable for simple myoelectric prostheses.

Art. no.	Size	Upper arm connection diameter	Lamination ring diameter
12K5=45	6¾ – 7¼	67 mm	45 mm
12K5=50	7¾ – 8¼	67 mm	50 mm

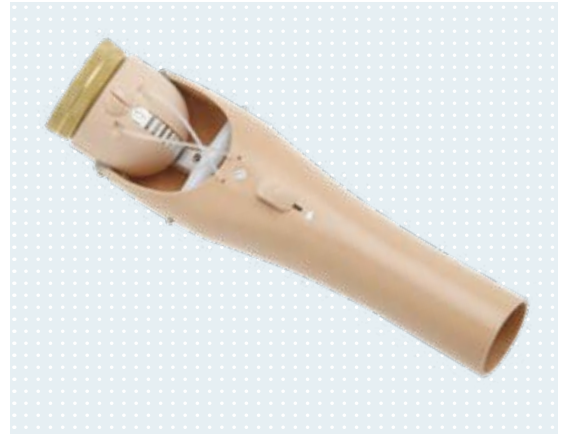

647G469

### Elbow component with passive lock

Art. no. 12K20

Elbow component with manual elbow locking (13 locking positions in approx. 8° increments) and upper arm rotation joint (humeral rotation feature). The plastic forearm shell has a length of approx. 260 mm and a circumference of approx. 245 mm. It is made of dark brown plastic (corresponds to skin colour 15). It has an opening for the 9E185=50-1 extension cable for simple myoelectric prostheses.

Art. no.	Size	Upper arm connection diameter	Lamination ring diameter
12K20=45	6¾ – 7¼	67 mm	45 mm
12K20=50	7¾ – 8	67 mm	50 mm



647G469

### Extension cable

Art. no. 9E185=50-1

The 9E185=50-1 extension cable has a partial tube sheathing and a sealing ring. It can be used in conjunction with 12K5 and 12K20 elbow components for simple myoelectric prostheses.

Art. no.	Length
9E185=50-1	500 mm

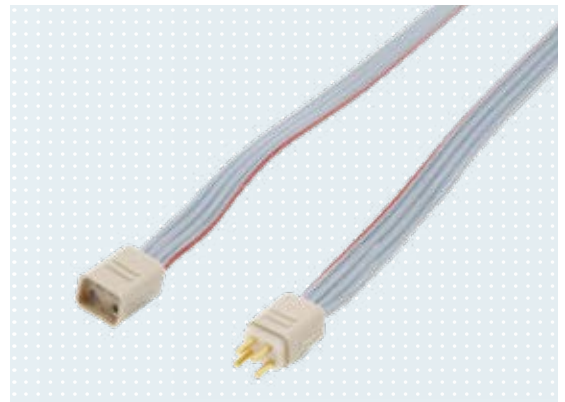

## ▶ Liners and accessories

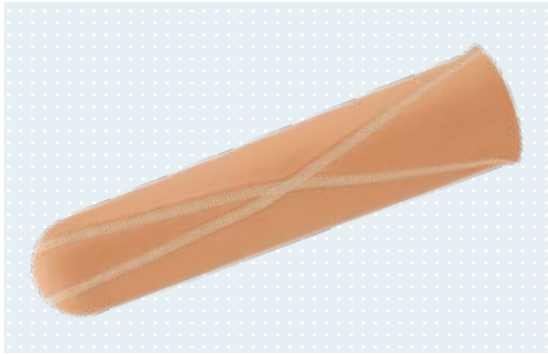

647G772

### IntoLiner Acclimate

Art. no. 14Y3

The IntoLiner Acclimate, together with a custom fabricated frame socket, represents the connection between the residual limb and the arm prosthesis. Wearer comfort is improved by the breathable, moisture wicking and antibacterial textile material. It equalises heat and cold. In order to fully benefit from these features, we recommend fabricating a custom frame socket. An example can be found in the 646T3=3.5\* technical information. For fitting below-elbow residual limbs with a residual limb length of 10 cm and up.

#### Key features at a glance

- Temperature equalising
- Moisture wicking, breathable and antibacterial
- Available in various sizes
- Adjustable to the residual limb length
- Washable at 30°C



#### Measure correctly!

- For correct size selection, measure the circumference 3 cm proximal from the end of the residual limb. Subtract 1 to 2 cm from the measured circumference according to the soft tissue situation.

Art. no.	Length	Circumference 1
14Y3=140	290 mm	140 mm
14Y3=160	290 mm	160 mm
14Y3=180	290 mm	180 mm
14Y3=200	290 mm	200 mm
14Y3=220	290 mm	220 mm

- The colour of the liner roughly corresponds to colour -4 (beige) according to the 646M3 colour sample set.

## ▶ Liners and accessories

### Skeo Up

Art. no. 14Y5

The further development of the proven silicone ArmLiner (article no. 14Y1), supplemented to include components of the Skeo family for lower limbs: Skeo Up (article no. 14Y5). A non-adhesive outer coating was applied to this liner, eliminating the need for donning spray and making it much easier to put on and take off. The roughened interior contour also reduces the perception of perspiration and feels comfortable on the skin. The new matrix improves tear resistance by reducing longitudinal expansion. A pin is used to establish the connection to the lock built into the prosthetic socket.

#### Key features at a glance

- Suitable for residual limb sockets from a residual limb length of 10 cm on the upper arm and forearm
- Easier to put on and take off thanks to a special outer coating
- Very comfortable to wear due to roughened interior contour
- Highly robust thanks to new matrix
- New design

Art. no.	Length	Circumference 1	Circumference 2
14Y5=110	200 mm	110 mm	150 mm
14Y5=140	200 mm	140 mm	160 mm
14Y5=160	200 mm	160 mm	180 mm
14Y5=180	200 mm	180 mm	200 mm
14Y5=200	200 mm	200 mm	220 mm
14Y5=220	200 mm	220 mm	240 mm



647G323



#### Measure correctly!

- For correct size selection, measure the circumference 3 cm proximal from the end of the residual limb. Subtract 1 to 2 cm from the measured circumference according to the soft tissue situation.

### Lock set

Art. no. 14A1

Lock set to secure a silicone ArmLiner (article no. 14Y1 and 14Y5) in the prosthetic socket.



### Pin

Art. no. 14A107

The pin is available in various lengths.

Art. no.	Length
14A107	23 mm
14A107=1	28 mm
14A107=2	33 mm



## ▶ Liners and accessories



### Donning spray

Art. no. 640F18

The donning spray is needed among other things for donning and removal of the liner or prosthetic glove (silicone, PVC).

Art. no.	Contents
640F18	90 ml
640F18=900	900 ml (refill)



### Derma Clean

Art. no. 453H10

Derma Clean cleanses gently and reliably. It is pH-neutral, free of alkali and phosphates, and features an antibacterial formula.

Art. no.	Order by	Contents
453H10	6 bottles	300 ml
453H10=1	1 bottle	300 ml



### Dummy set

Art. no. 14A111

Dummy set for aligning a prosthesis with the silicone ArmLiner. The set consists of a pin dummy with and without thread and a shape dummy for the lamination ring.



### Lock with release pin

Art. no. 14A110

Lock with release pin serves as a spare part for article no. 14A1.

# ▶ Above-elbow & below-elbow harnesses with accessories

## Triple-control above-elbow harness

Art. no. 21A35

The triple-control above-elbow harness is used to secure the prosthetic socket and for the control of body-powered prostheses. It is compatible with right and left-side devices.

Art. no.	Version
21A35=1	with perlon cable
21A35=2	with steel cable

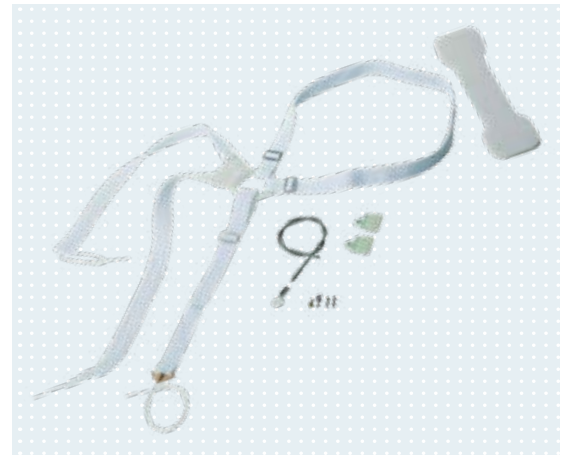

647H455

## Below-elbow harness

Art. no. 21A36

The below-elbow harness is intended for fixation of the prosthetic socket and for control of body-powered prostheses. It is compatible with right and left-side devices.

Art. no.	Version
21A36=1	with perlon cable
21A36=2	with steel cable



647H455

## Bowden cable

Art. no. 21A37=1

The Bowden cable is a spare part for article no. 21A35=1. Spiral length: 500 mm.



## Coupler

Art. no. 10Y32

The coupler with the ball-shaft adapter article no. 10Y31=\* is a connecting element.

Art. no.	Compatible with
10Y32=1	21A18=2 Perlon cable
10Y32=2	651D4=2 Steel cable

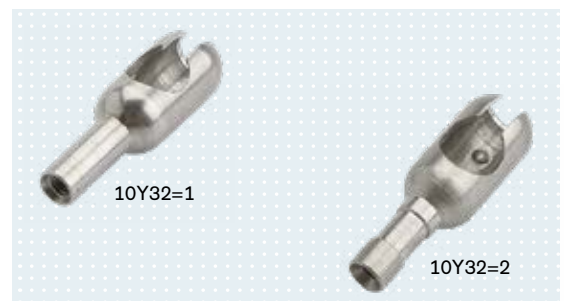

## ▶ Above-elbow & below-elbow harnesses with accessories



### Ball-shaft adapter

Art. no. 10Y31

The ball-shaft adapter with the coupler article no. 10Y32=\* is a connecting element.

Art. no.	Compatible with
10Y31=1	21A18=2 Perlon cable
10Y31=2	651D4=2 Steel cable
10Y31=7	3/64" steel cable
10Y31=8	1/16" steel cable
10Y31=9	3/32" steel cable



### Ring

Art. no. 21Y194

Harness ring with integrated cable guide.



### Stainless steel buckle

Art. no. 21Y195=25

Stainless steel buckle for positioning and fixing the harness strap.



### Connecting bracket

Art. no. 21Y197=1



## ▶ Above-elbow & below-elbow harnesses with accessories

### Axillary protector for body harnesses

Art. no. 21A29

Optional silicone axillary protector to ensure pleasant wearing comfort.

Art. no.	Width
21A29=18	18 mm
21A29=25	25 mm

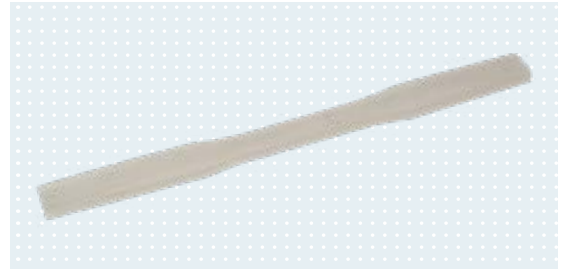

### Axilla pad set

Art. no. 21A38

Axilla pad set made of white foam. Contents: 5 pieces.



### Strap buckle

Art. no. 21Y199

Strap buckle for a seamless connection of the elastic harness strap (article no. 623G23) to the prosthetic socket. Consisting of sleeve, lower part, upper part and spacer sleeve.

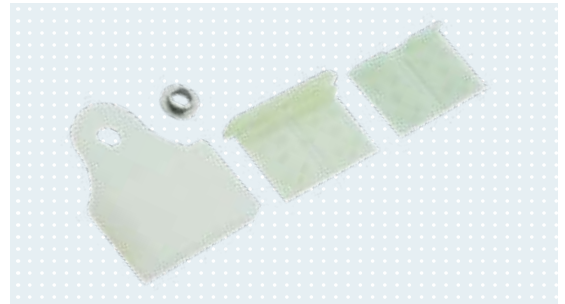

### Spacer sleeve

Art. no. 21Y203

Spacer sleeve for strap buckle (article no. 21Y199).



## ▶ Above-elbow & below-elbow harnesses with accessories

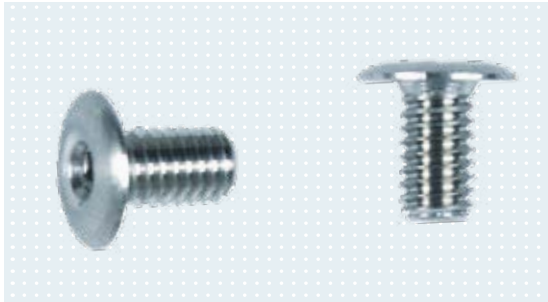

### Socket screw with Allen head

Art. no. 503F3

Socket screw (contents: 2 pieces) with Allen head. With M4 thread (length 7 mm). The head diameter is 8 mm.



### Elastic harness strap

Art. no. 623G23

Elastic harness strap in white with tunnel-shaped cable guide.  
Order by the metre



### Harness strap

Art. no. 623H23

White harness strap. Order by the metre

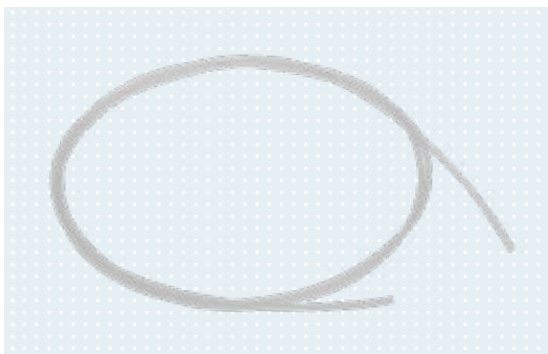

### Perlon cable

Art. no. 21A18

Perlon cable with a diameter of 2 mm.

Art. no.	Length	Order by
21A18=2X1	1 m	linear metres
21A18=2X5	5 m	linear metres
21A18=2X10	10 m	linear metres
21A18=2X25	25 m	linear metres

## ▶ Above-elbow & below-elbow harnesses with accessories

### Setting nut

Art. no. 29C5

Setting nut (knurled), stainless steel.

Art. no.	Thread	Length	Head diameter	Stud diameter
29C5=M4X9	M4	3.6 mm	9 mm	5.5 mm
29C5=M5X18	M5	3.6 mm	18 mm	6.5 mm



### Countersunk head screw

Art. no. 501S28=M3.5X5

Nickel-plated countersunk head screw for article no. 16H1 and 16H2.



### Eyelet cable anchor, large

Art. no. 21A5



### “D” ring

Art. no. 21A16

“D” ring with a clearance width of 13 mm for flexion cable.



## ▶ Above-elbow & below-elbow harnesses with accessories

---



### Lamination disc, serrated

Art. no. 507S15

Serrated lamination disc with bore (diameter: 3 mm). Exterior diameter 13.8 mm (contents: 2 pieces).

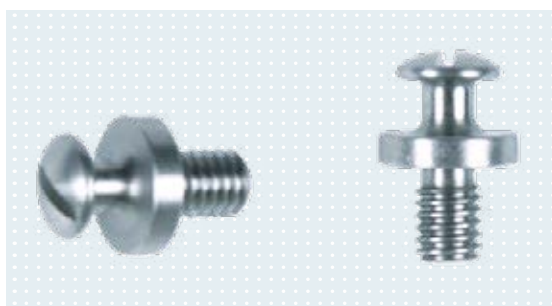

### Threaded support fastener

Art. no. 516S3

Threaded support fastener with M4 thread and a thread length of 5.5 mm.



### Loop

Art. no. 514Z3=25

Loop with a clearance width of 25 mm.

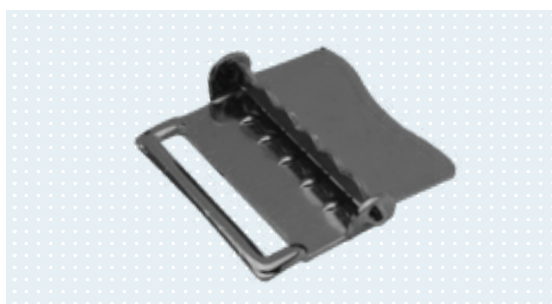

### Clamp buckle

Art. no. 514K3=27

## ▶ Above-elbow & below-elbow harnesses with accessories

### Hollow rivet

Art. no. 504H3=11-100

Hollow rivet with open lower part. Head diameter: 11 mm.



### Screw coupling

Art. no. 10Y19=2

The screw coupling serves as a connection piece between a steel cable and perlon cable or spectra cable as well as between a perlon cable and perlon cable or spectra cable. Consists of coupling sleeve and coupling screw, which is screwed onto the 21A18=\* perlon cable or through which a spectra cable is threaded and tied up.



### Crimping tool

Art. no. 736Y6

Crimping tool for crimping the coupling screw and clamp sleeve as well as the ball-shaft adapter (article no. 10Y31=2) and coupler (article no. 10Y32=2) onto the steel cable (article no. 651D4=2).



 647H13









# Passive

## modular arm components

### Clever connection

Tube skeleton designs with foam covers are characteristic of the modular system in upper limb prosthetics. This design is used primarily for fittings with passive arm prostheses for proximal amputation levels.

Corresponding modular arm components are available for transhumeral amputations at various residual limb lengths; they are connected to the prosthetic socket by a lamination ring and then concealed by a foam cover.

#### On the following pages you will find











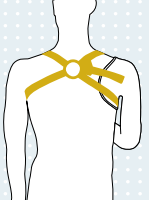



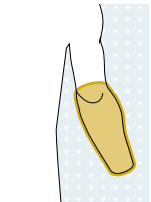

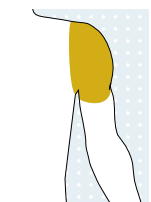



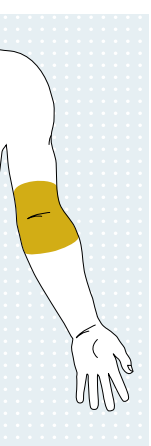



- Overview of passive mechanical arm components
- Terminal devices
- Prosthetic gloves
- Adapters
- Terminal device and colour determination
- Physolino baby hand
- Passive prosthetic hands for children, women and men
- Arm components
- Shoulder joints
- Elbow joint bars
- Liners
- Body harnesses

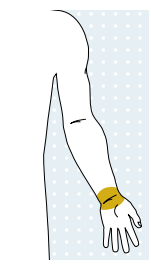

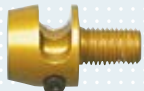
You can find our order forms  
in the download centre under

[www.ottobock.de/downloadcenter/](http://www.ottobock.de/downloadcenter/)

# Overview of passive mechanical arm components

<p><b>Body harness</b></p> 	 <p><b>Triple-control above-elbow harness</b> 21A35</p>	 <p><b>Below-elbow harness</b> 21A36</p>	 <p><b>Transhumeral soft harness</b> 21A47</p>
<p><b>Liner</b></p> 	 <p><b>Skeo Up</b> 14Y5</p>	 <p><b>IntoLiner Acclimate</b> 14Y3</p>	
<p><b>Shoulder</b></p> 	<p><b>Shoulder joint</b></p>  <p><b>Ottobock ball shoulder joint</b> 12S7</p>	 <p><b>Ottobock shoulder joint</b> 12S4</p>	 <p><b>MovoShoulder Swing</b> 12S6</p>
<p><b>Elbow</b></p> 	<p><b>12R6 Transhumeral modular kit</b></p>  <p><b>Modular arm component</b> 12R2 for short above-elbow residual limbs</p>  <p><b>Adapter</b> 13R6</p>	<p><b>12R7 Modular shoulder disarticulation kit</b></p>  <p><b>Modular arm component</b> 12R4 for shoulder disarticulation</p>  <p><b>Adapter</b> 13R7</p>	<p><b>15K10 Modular foam kit</b></p>  <p><b>Pre-shaped foam block</b> 15K3</p>  <p><b>Mounting flange</b> 13R8</p>
<p><b>Wrist</b></p> 	<p><b>Wrist joint connections</b></p>  <p><b>For system hands</b> 10R2 Adapter</p>	 <p><b>For system hands</b> 10R3 Adapter with flexion</p>	 <p><b>For passive prosthetic hands</b> 10R1 Adapter</p>  <p><b>For passive prosthetic hands</b> 10R4 Knurled plate</p>
<p><b>Terminal device</b></p> 	<p><b>Hands and prosthetic gloves</b></p>  <p><b>Passive prosthetic hand</b> Inner hand 8S7 8S8 8S9</p>	 <p><b>Prosthetic glove</b> 8S4 8S5 8S6</p>	 <p><b>Passive system hand</b> 8K18 8K19</p>  <p><b>Prosthetic glove</b> 8S4; 8S4N 8S5; 8S5N 8S6; 8S6N 8S11; 8S11N</p>

## ▶ Terminal devices and accessories

### System hand, passive

Art. no. 8K18/8K19

The passive system hand is suitable for all residual limb lengths with passive prostheses. It is opened with the sound hand and closes independently. The system is lightweight and stable. With threaded stud (article no. 8K18: M12X1.5, 8K19: 1/2"-20) and system inner hand. Available in sizes 6 3/4 (children), 7 1/4 (adolescents and women), 7 3/4 and 8 (men).



 647G444

Art. no.	Side	Size	Inner hand	Approx. weight
8K18=L6¾	Left (L)	6¾	8X14=L6¾	185 g
8K18=L7¼	Left (L)	7¼	8X14=L7¼	250 g
8K18=L7¾	Left (L)	7¾	8X14=L7¾	280 g
8K18=L8	Left (L)	8	8X14=L8	290 g
8K18=R6¾	Right (R)	6¾	8X14=R6¾	185 g
8K18=R7¼	Right (R)	7¼	8X14=R7¼	250 g
8K18=R7¾	Right (R)	7¾	8X14=R7¾	280 g
8K18=R8	Right (R)	8	8X14=R8	290 g

Art. no.	Side	Size	Inner hand	Approx. weight
8K19=L6¾	Left (L)	6¾	8X14=L6¾	185 g
8K19=L7¼	Left (L)	7¼	8X14=L7¼	250 g
8K19=L7¾	Left (L)	7¾	8X14=L7¾	280 g
8K19=L8	Left (L)	8	8X14=L8	290 g
8K19=R6¾	Right (R)	6¾	8X14=R6¾	185 g
8K19=R7¼	Right (R)	7¼	8X14=R7¼	250 g
8K19=R7¾	Right (R)	7¾	8X14=R7¾	280 g
8K19=R8	Right (R)	8	8X14=R8	290 g

• The prosthetic glove must be ordered separately. See pages 171–173.

## ▶ Terminal device and accessories



### Lamination ring

Art. no. 9E94

Lamination ring available for hand sizes 6 <sup>3</sup>/<sub>4</sub>, 7 <sup>1</sup>/<sub>4</sub>, 7 <sup>3</sup>/<sub>4</sub> and 8.

Art. no.	Diameter	Size
9E94=44	44 mm	6 <sup>3</sup> / <sub>4</sub>
9E94=50	50 mm	7 <sup>1</sup> / <sub>4</sub> , 7 <sup>3</sup> / <sub>4</sub> and 8

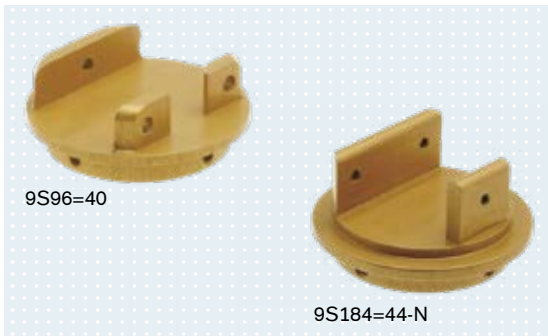

### Chassis

Art. no. 9S96/9S184

Chassis for overlong forearm and wrist disarticulation residual limbs. Compatible with lamination ring (article no. 9E94).

Art. no.	Diameter	Size
9S96=40	40 mm	6 <sup>3</sup> / <sub>4</sub>
9S184=44-N	44 mm	7 <sup>1</sup> / <sub>4</sub>
9S184=48-N	48 mm	7 <sup>3</sup> / <sub>4</sub> and 8



### Set screw

Art. no. 506G4

Set screw for chassis. Four set screws are required per chassis.

Art. no.	Compatible with
506G4=M3X5	9S96=40 Chassis
506G4=M4X5	9S184 Chassis

## ▶ Terminal device and accessories

### System inner hand

Art. no. 8X14

System inner hand with support for little finger and ring finger as well as retainer ring (article no. 9S187).

Art. no.	Side	Size
8X14=L6¾	Left (L)	6¾
8X14=L7¼	Left (L)	7¼
8X14=L7¾	Left (L)	7¾
8X14=L8	Left (L)	8
8X14=R6¾	Right (R)	6¾
8X14=R7¼	Right (R)	7¼
8X14=R7¾	Right (R)	7¾
8X14=R8	Right (R)	8



### Lock ring, wide

Art. no. 9S187

Wide lock ring. Compatible with the system inner hand (article no. 8X14) in hand sizes 7¼, 7¾ and 8.

Art. no.	Size
9S187=7¼	7¼
9S187=7¾	7¾
9S187=8¼	8¼

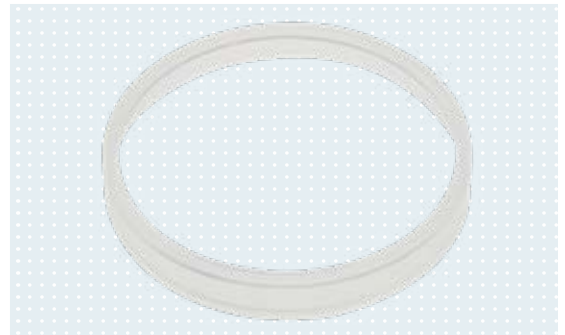

### Retainer ring

Art. no. 9S15=42

Retainer ring to secure the system inner hand (article no. 8X14) in size 6¾.

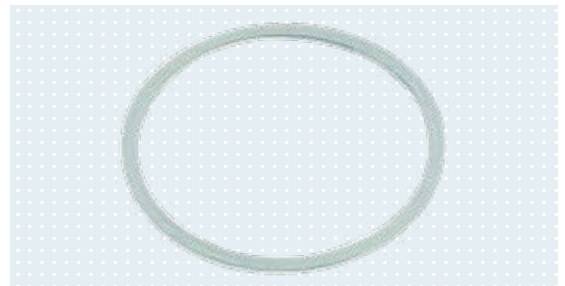

### Finger and thumb cover

Art. no. 9S6

Finger and thumb cover compatible with hand sizes 6¾, 7¼, 7¾ and 8.



## ▶ Terminal device and accessories



### Chassis

Art. no. 9S67

Chassis with threaded stud M12X1.5.

Art. no.	Side	Diameter	Compatible with
9S67=L40	Left (L)	40 mm	8K18=L6¾
9S67=L44-N	Left (L)	44 mm	8K18=L7¼
9S67=L48-N	Left (L)	48 mm	8K18=L7¾ and 8K18=L8
9S67=R40	Right (R)	40 mm	8K18=R6¾
9S67=R44-N	Right (R)	44 mm	8K18=L7¼
9S67=R48-N	Right (R)	48 mm	8K18=L7¾ and 8K18=L8

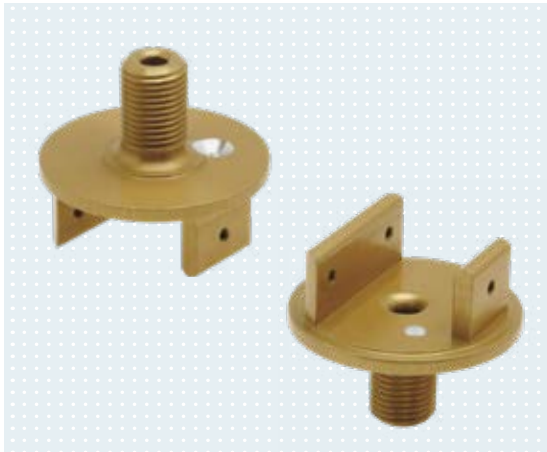

### Chassis

Art. no. 9S65

Chassis with 1/2"-20 threaded stud.

Art. no.	Side	Diameter	Compatible with
9S65=L40	Left (L)	40 mm	8K19=L6¾
9S65=L44-N	Left (L)	44 mm	8K19=L7¼
9S65=L48-N	Left (L)	48 mm	8K19=L7¾
9S65=R40	Right (R)	40 mm	8K19=R6¾
9S65=R44-N	Right (R)	44 mm	8K19=L7¼
9S65=R48-N	Right (R)	48 mm	8K19=L7¾



### Flange button head socket screw

Art. no. 501T52=M3X6

The M3X6-threaded flange button head socket screw is used to bolt the chassis to the system hand base (all sizes). Two pieces are required.



### Flange button head socket screw

Art. no. 501T52=M3X8

The M3X8-threaded flange button head socket screw is used to bolt the chassis to the system hand cover plate (all sizes). One screw is required.



# ▶ Prosthetic gloves

## Prosthetic glove for children

Art. no. 8S6=170X65

The prosthetic glove for children is available in size 6¾ and in 18 colours.

In addition to the standard prosthetic glove, Ottobock also offers additional models of the Skin Natural series. The multilayer structure of the gloves gives them a depth effect so that they have a very vivid appearance. The outer translucent layer allows the coloured fibres of the material to shine through. This simulates the natural vein structure of human skin. Please add an N before the = in the article number.

### Example

- 8S11=210X78L (standard glove)
- 8S11N=210X78L (Skin Natural)

Art. no.	Side	Size	Sleeve length
8S6N=170X65L	Left (L)	6¾	300 mm
8S6N=170X65R	Right (R)	6¾	300 mm
8S6=170X65L	Left (L)	6¾	300 mm
8S6=170X65R	Right (R)	6¾	300 mm

- The entire Skin Natural colour palette is produced with seven colours. The new 646M47 colour scale helps when selecting the right sample.



647G468 (standard glove)  
647G571 (Skin Natural)

## Prosthetic glove for adolescents

Art. no. 8S4=190X76

The prosthetic glove for adolescents is available in size 7¼ and in 18 colours.

In addition to the standard prosthetic glove, Ottobock also offers additional models of the Skin Natural series. The multilayer structure of the gloves gives them a depth effect so that they have a very vivid appearance. The outer translucent layer allows the coloured fibres of the material to shine through. This simulates the natural vein structure of human skin. Please add an N before the = in the article number.

### Example

- 8S11=210X78L (standard glove)
- 8S11N=210X78L (Skin Natural)

Art. no.	Side	Size	Sleeve length
8S4N=190X76L	Left (L)	7¼	215 mm
8S4N=190X76R	Right (R)	7¼	215 mm
8S4=190X76L	Left (L)	7¼	215 mm
8S4=190X76R	Right (R)	7¼	215 mm

- The entire Skin Natural colour palette is produced with seven colours. The new 646M47 colour scale helps when selecting the right sample.



647G468 (standard glove)  
647G571 (Skin Natural)

- Special cleaner for prosthetic gloves is found on page 234.

## ▶ Prosthetic gloves



 647G468 (standard glove)  
647G571 (Skin Natural)

### Prosthetic glove for men

Art. no. 8S4=210X78

The prosthetic glove for men is available in size 7  $\frac{3}{4}$  and in 18 colours.

In addition to the standard prosthetic glove, Ottobock also offers additional models of the Skin Natural series.

The multilayer structure of the gloves gives them a depth effect so that they have a very vivid appearance. The outer translucent layer allows the coloured fibres of the material to shine through. This simulates the natural vein structure of human skin.

Please add an N before the = in the article number.

#### Example

- 8S11=210X78L (standard glove)
- 8S11N=210X78L (Skin Natural)

Art. no.	Side	Size	Sleeve length
8S4N=210X78L	Left (L)	7 $\frac{3}{4}$	220 mm
8S4N=210X78R	Right (R)	7 $\frac{3}{4}$	220 mm
8S4=210X78L	Left (L)	7 $\frac{3}{4}$	220 mm
8S4=210X78R	Right (R)	7 $\frac{3}{4}$	220 mm

- The entire Skin Natural colour palette is produced with seven colours. The new 646M47 colour scale helps when selecting the right sample.



 647G468 (standard glove)  
647G571 (Skin Natural)

### Prosthetic glove for men

Art. no. 8S4=220X80

The prosthetic glove for men is available in size 8 and in 18 colours.

In addition to the standard prosthetic glove, Ottobock also offers additional models of the Skin Natural series. The multilayer structure of the gloves gives them a depth effect so that they have a very vivid appearance. The outer translucent layer allows the coloured fibres of the material to shine through. This simulates the natural vein structure of human skin. Please add an N before the = in the article number.

#### Example

- 8S11=210X78L (standard glove)
- 8S11N=210X78L (Skin Natural)

Art. no.	Side	Size	Sleeve length
8S4N=220X80L	Left (L)	8	225 mm
8S4N=220X80R	Right (R)	8	225 mm
8S4=220X80L	Left (L)	8	225 mm
8S4=220X80R	Right (R)	8	225 mm

- The entire Skin Natural colour palette is produced with seven colours. The new 646M47 colour scale helps when selecting the right sample.

- Special cleaner for prosthetic gloves is found on page 234.

# ▶ Prosthetic gloves

## Prosthetic glove for women

Art. no. 8S5=195X78

The prosthetic glove for women is available in size 7¼ and in 18 colours.

In addition to the standard prosthetic glove, Ottobock also offers additional models of the Skin Natural series.

The multilayer structure of the gloves gives them a depth effect so that they have a very vivid appearance. The outer translucent layer allows the coloured fibres of the material to shine through. This simulates the natural vein structure of human skin. Please add an N before the = in the article number.

### Example

- 8S11=210X78L (standard glove)
- 8S11N=210X78L (Skin Natural)

Art. no.	Side	Size	Sleeve length
8S5N=195X78L	Left (L)	7¼	340 mm
8S5N=195X78R	Right (R)	7¼	340 mm
8S5=195X78L	Left (L)	7¼	340 mm
8S5=195X78R	Right (R)	7¼	340 mm

- The entire Skin Natural colour palette is produced with seven colours. The new 646M47 colour scale helps when selecting the right sample.

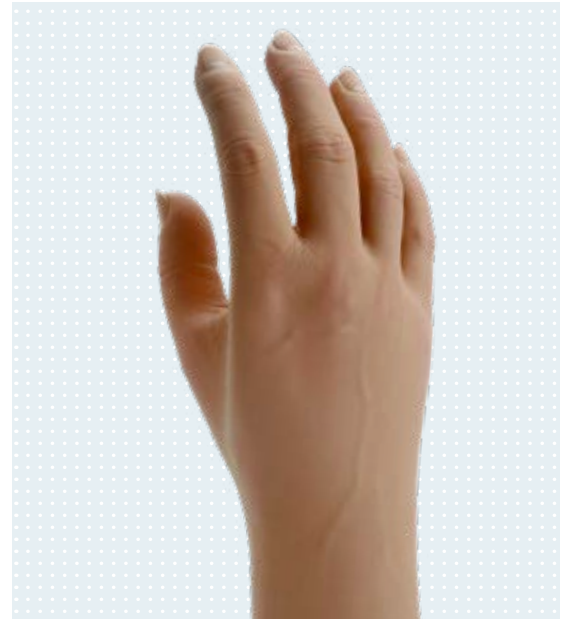

-  647G468 (standard glove)  
647G571 (Skin Natural)

- Special cleaner for prosthetic gloves is found on page 234.

## ▶ Adapter



647G454

### Adapter

Art. no. 10R1

Adapter with threaded stud M12X1.5 to connect a passive inner hand to modular arm components.



647G454

### Adapter

Art. no. 10R2

Adapter with interior thread for connecting a hook or system hand to modular arm components.

Art. no.	Connection diameter	Interior thread diameter
10R2=M12X1.5	20 mm	M12X1.5
10R2=½"-20	20 mm	½"-20



647G454

### Adapter with flexion

Art. no. 10R3

Flexion adapter with interior thread for connecting a hook or system hand to modular arm components.

Art. no.	Connection diameter	Interior thread diameter
10R3=M12X1.5	20 mm	M12X1.5
10R3=½"-20	20 mm	½"-20

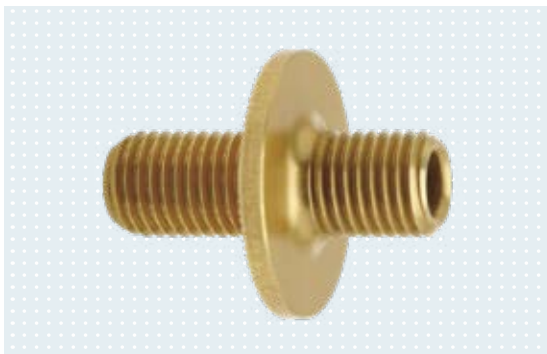

647G454

### Knurled plate

Art. no. 10R4

Knurled plate with threaded stud (bilateral) to connect a passive inner hand to adapters article no. 10R2 and 10R3.

Art. no.	Threaded stud	Compatible with
10R4=M12X1.5	M12X1.5	10R2=M12X1.5 Adapter, 10R3=M12X1.5 Adapter with flexion
10R4=½"-20	M12X1.5, ½"-20	10R2=½"-20 Adapter, 10R3=½"-20 Adapter with flexion

## ▶ Adapter

### Modular adapter for ArmLiners

Art. no. 13R11

The adapter is used to connect the Ottobock ArmLiner (article no. 14Y5) to the lock set (article no. 14A1) and the Ottobock modular components.







 647G164

# ▶ Terminal device and colour determination

The following illustrations of the prosthetic hands are true to the original, and will help you and your patients select an individual artificial hand. The passive prosthetic hands consist of an inner hand and prosthetic glove. The standard inner hand is foam-formed with wire reinforcement in each finger. This provides high degree of stability while keeping the weight low. It can be used universally thanks to different attachment options. The prosthetic glove's shape, colour and surface texture simulate the natural hand down to the details. The 43 different models for children, women and men are illustrated for the right hand and are marked for identification as in the table below.

User	Prosthetic glove	Inner hand
Children	8S6=	8S9=
Women	8S5=	8S8=
Men	8S4=	8S7=

On each page of the illustrations, the order reference numbers are indicated under the passive prosthetic hand for the prosthetic glove (1st line) and inner hand (2nd line, to the left and right, respectively).

Side	Art. no.	Check no.	Art. no.	Side
	8S5=165X72L	40	8S5=167X72R	
	8S8=165X72L		8S8=167X72R	

### Determining the order number

To precisely determine the correct size of the prosthetic glove and inner hand for a new prosthesis or partial hand prosthesis, measure your patient's "metacarpal circumference" (B) and "middle finger length" (C) according to the following sketch.

Then determine the reference number, taking into account the measurements for the "metacarpal circumference" (B) and "middle finger length" (C).

- A** = wrist circumference
- B** = metacarpal circumference
- C** = middle finger length
- D** = sleeve circumference
- E** = length to elbow (not specified for short sleeve)

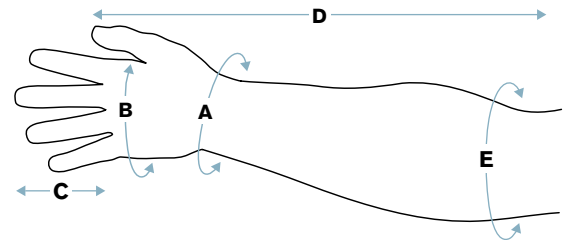

A	B	C	E	D
140 mm	160 mm	68 mm	200 mm	384 mm

These measurements result, for example, in the following reference number for the prosthetic glove and corresponding inner hand. The real measurement of the inner hand is reduced by the material thickness of the prosthetic glove.

8S5=	165X72	L
8S8=		

The final step in the selection process is to select the colour shade, i.e. the colour code. The standard gloves are available in 18 different shades. Free original glove colour samples for standard gloves can be ordered under 646M3. You can order the original glove colour samples for the Skin Natural series with 646M47 (7 colours: 2, 4, 6, 8, 11, 14, 16). The complete reference number for your order is shown in the table to the side.

8S5=	165X72	L	6
8S8=	165X72	L	

A "T" must be added to the reference number if the inner hand is needed for a partial hand prosthesis.

8S8=	165X72	L	T
------	--------	---	---

### Notice

Some gloves are only produced on request. Please ask your customer service representative for delivery dates.

**i** All measurements are stated in mm. A measurement difference of  $\pm 5$  mm is reserved. The check number is always noted on the wrist of the inner hand!



# ▶ Terminal device and colour determination

## Prosthetic gloves and inner hands for children

Order reference number			Measurements for the left hand						Measurements for the right hand						
Prosthetic glove	Inner hand	Reference number	Metacarpal circumference (B)	Middle finger length (C)	Wrist circumference (A)	Sleeve circumference (D)	Length to elbow (E)	Check no.	Reference number	Metacarpal circumference (B)	Middle finger length (C)	Wrist circumference (A)	Sleeve circumference (D)	Length to elbow (E)	Illustration on page
<b>8S6=</b>	<b>8S9=</b>	<b>115X38L</b>	117	38	107	145	147	40	<b>115X37R</b>	106	35	103	133	165	174
		<b>130X51L</b>	120	40	106	146	205	41	<b>134X52R</b>	125	40	110	155	198	174
		<b>142X50L</b>	130	42	110	153	220	42	<b>139X51R</b>	130	41	110	162	225	175
		<b>151X58L</b>	135	50	120	166	220	44	<b>151X59R</b>	137	50	123	168	230	175
		<b>158X54L</b>	160	52	130	190	258	86	<b>159X53R</b>	160	57	130	185	250	176
		<b>165X68L</b>	160	63	134	184	280	48	<b>158X68R</b>	150	59	135	185	280	176
		<b>168X70L</b>	156	59	137	183	295	47	<b>166X70R</b>	160	65	140	176	300	177
		<b>170X65L</b>	157	54	141	188	291	43	<b>170X65R</b>	155	55	145	183	290	177

## Prosthetic gloves and inner hands for women

Order reference number			Measurements for the left hand						Measurements for the right hand						
Prosthetic glove	Inner hand	Reference number	Metacarpal circumference (B)	Middle finger length (C)	Wrist circumference (A)	Sleeve circumference (D)	Length to elbow (E)	Check no.	Reference number	Metacarpal circumference (B)	Middle finger length (C)	Wrist circumference (A)	Sleeve circumference (D)	Length to elbow (E)	Illustration on page
<b>8S5=</b>	<b>8S8=</b>	<b>165X72L</b>	159	65	138	200	315	34	<b>167X72R</b>	163	63	131	199	330	178
		<b>174X74L</b>	157	63	137	190	315	32	<b>175X76R</b>	163	61	135	182	315	178
		<b>180X80L</b>	164	67	150	219	395	29	<b>176X80R</b>	170	69	152	217	365	179
		<b>182X84L</b>	167	67	143	220	345	28	<b>190X84R</b>	186	68	149	218	345	179
		<b>184X75L</b>	164	64	131	222	355	36	<b>187X74R</b>	183	65	143	226	325	180
		<b>184X78L</b>	172	66	154	223	300	37	<b>184X78R</b>	180	69	153	223	310	180
		<b>185X75L</b>	173	65	144	202	313	23	<b>181X75R</b>	171	65	147	206	310	181
		<b>188X79L</b>	183	74	156	226	345	70	<b>187X79R</b>	182	74	159	235	355	181
		<b>190X77L</b>	175	66	138	213	335	20	<b>190X77R</b>	183	65	144	211	330	182
		<b>190X93L</b>	176	80	152	220	375	30	<b>186X92R</b>	184	81	154	214	380	182
		<b>192X78L</b>	179	68	150	230	340	24	<b>191X78R</b>	186	69	148	231	335	183
		<b>194X82L</b>	165	65	159	212	345	27	<b>189X84R</b>	178	69	152	210	365	183
		<b>195X78L</b>	187	65	153	217	345	38	<b>195X78R</b>	187	66	150	212	335	184
		<b>195X79L</b>	181	66	151	230	315	25	<b>200X79R</b>	199	70	157	244	330	184
		<b>208X89L</b>	193	75	165	234	385	19	<b>210X89R</b>	199	75	171	238	380	185

## ▶ Terminal device and colour determination

### Prosthetic gloves and inner hands for men

Order reference number		Measurements for the left hand							Measurements for the right hand						
Prosthetic glove	Inner hand	Reference number	Metacarpal circumference (B)	Middle finger length (C)	Wrist circumference (A)	Sleeve circumference (D)	Length to elbow (E)	Check no.	Reference number	Metacarpal circumference (B)	Middle finger length (C)	Wrist circumference (A)	Sleeve circumference (D)	Length to elbow (E)	Illustration on page
<b>8S4=</b>	<b>8S7=</b>	<b>202X74L</b>	193	70	155	229	375	58	<b>206X76R</b>	190	70	156	220	375	186
		<b>203X83L</b>	190	71	158	235	350	16	<b>199X82R</b>	185	70	155	230	340	186
		<b>203X85L</b>	200	73	161	230	375	15	<b>206X85R</b>	190	75	162	232	375	187
		<b>205X81L</b>	194	70	165	224	378	5	<b>205X81R</b>	180	65	170	220	380	187
		<b>206X80L</b>	198	71	177	250	380	60	<b>205X80R</b>	190	73	175	225	370	188
		<b>206X87L</b>	190	78	151	218	360	13	<b>215X88R</b>	193	75	164	240	370	188
		<b>207X86L</b>	187	76	152	229	360	57	<b>209X86R</b>	194	76	155	226	380	189
		<b>208X85L</b>	192	70	162	233	375	12	<b>212X83R</b>	193	73	165	232	370	189
		<b>211X88L</b>	194	75	161	244	370	59	<b>212X86R</b>	202	80	165	240	365	190
		<b>212X93L</b>	194	78	157	244	410	56	<b>215X93R</b>	197	76	153	235	425	190
		<b>213X85L</b>	200	69	175	243	380	54	<b>218X85R</b>	195	67	180	245	390	191
		<b>214X82L</b>	210	69	169	252	338	17	<b>215X83R</b>	195	70	175	255	350	191
		<b>218X85L</b>	210	75	167	234	405	8	<b>218X83R</b>	190	70	162	237	390	192
		<b>220X91L</b>	210	75	175	255	410	11	<b>214X90R</b>	192	76	153	223	415	192
		<b>221X81L</b>	208	70	174	251	351	51	<b>225X82R</b>	210	67	173	240	360	193
		<b>228X84L</b>	233	73	176	250	375	53	<b>222X84R</b>	208	78	170	246	360	193
		<b>228X88L</b>	216	72	174	250	330	52	<b>228X89R</b>	213	77	182	255	325	194
		<b>232X94L</b>	220	76	173	257	420	55	<b>230X93R</b>	211	75	176	253	390	194
<b>238X92L</b>	215	71	182	255	364	14	<b>244X94R</b>	207	70	179	260	370	195		

## ▶ Terminal device and colour determination

### Colour determination

To determine the colour of a standard prosthetic glove, please use the 646M3 colour sample set. Use the 646M47 colour sample set for a Skin Natural prosthetic glove. Please note that the colours shown here are only for orientation.

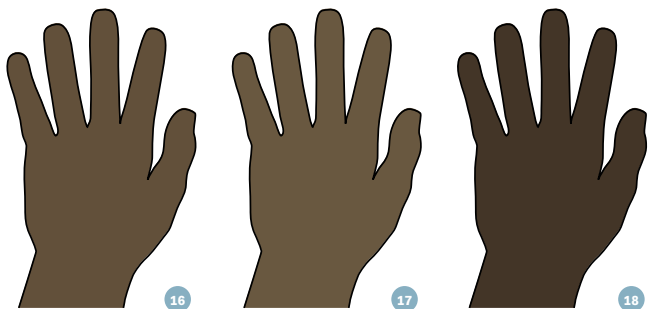
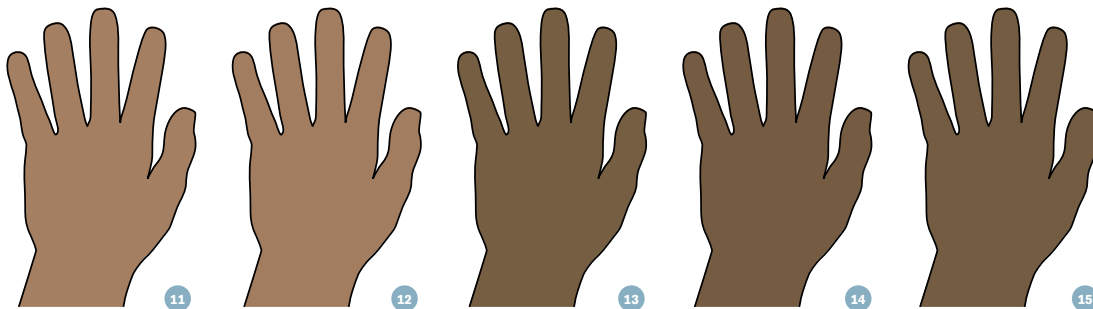
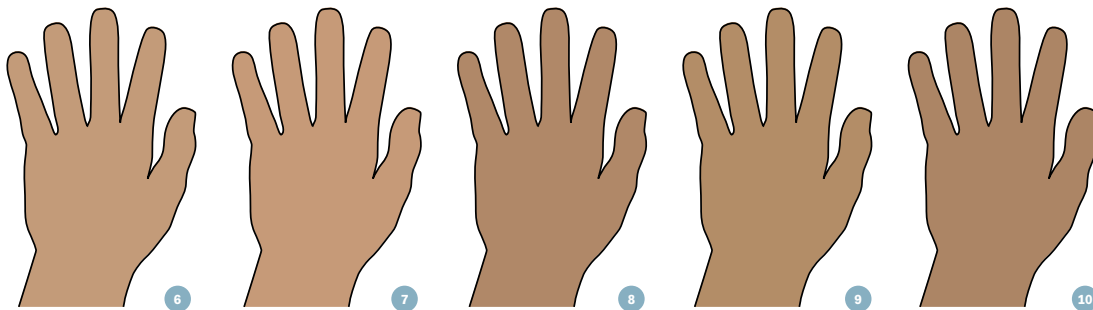
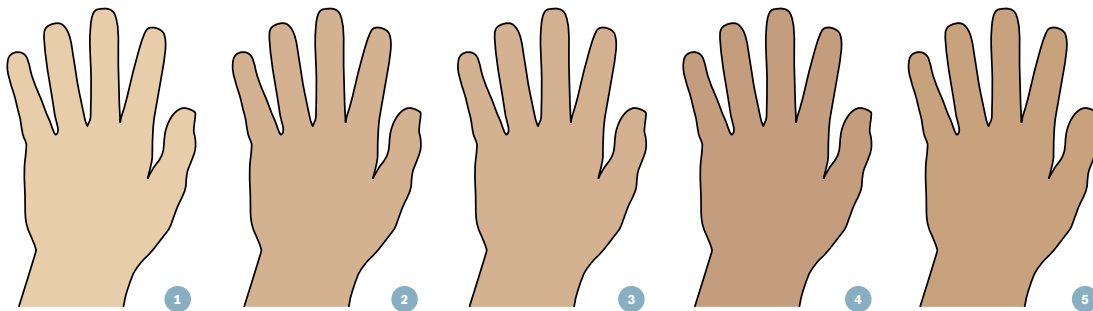

▶ Please contact Customer Service for information on availability and delivery times.

## ▶ Physolino baby hand and accessories

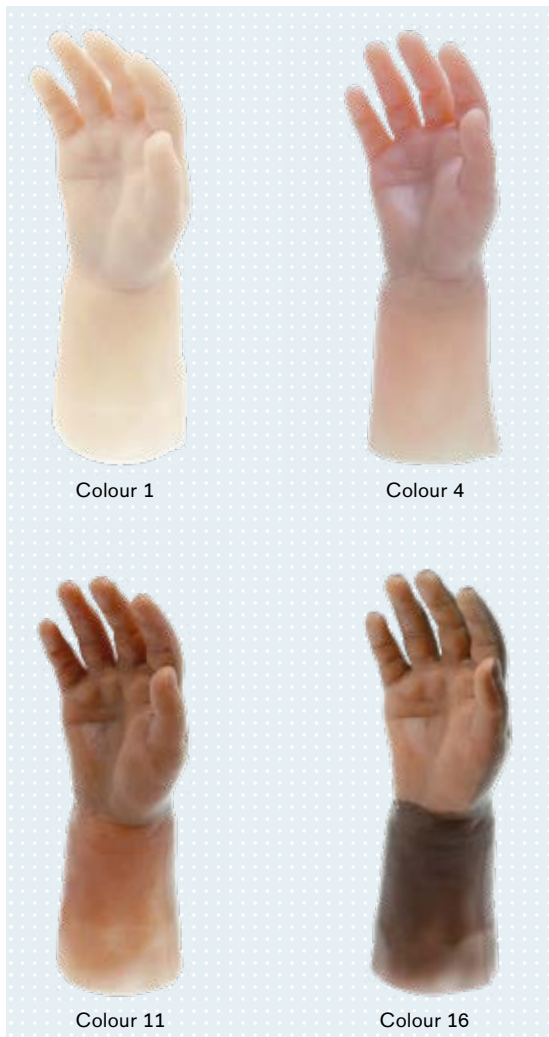

Colour 1

Colour 4

Colour 11

Colour 16

### Physolino baby hand

Art. no. 8K5

Physolino baby hand for babies and toddlers. The hand is made of medical grade silicone. Suitable for a hand circumference of approx. 110 mm and a finger length of approx. 40 mm. The colour corresponds approximately to the colour 1, 4, 11 or 16 of the Ottobock colour scale for prosthetic gloves. The Physolino baby hand is supplied with a lamination ring (article no. 11D31, diameter: 24 mm).

Art. no.	Side	Colour
8K5=1L1	Left (L)	1
8K5=1L4	Left (L)	4
8K5=1L11	Left (L)	11
8K5=1L16	Left (L)	16
8K5=1R1	Right (R)	1
8K5=1R4	Right (R)	4
8K5=1R11	Right (R)	11
8K5=1R16	Right (R)	16

- The lamination dummy (article no. 743Y42) for the Physolino baby hand can be found on page 173, compatible prosthetic gloves on pages 174–177.

647G360

## ▶ Physolino baby hand and accessories

### Lamination ring for Physolino baby hand

Art. no.11D31

Lamination ring for the Physolino baby hand with a diameter of 24 mm.  
Suitable for socket replacements.



### Wood hand adapter

Art. no.10A40

The wood hand adapter has a plastic threaded stud (M12x1.5) and is used to connect a passive inner hand to a forearm socket or elbow component. The diameter of the hand adapter is 60 mm, and modification to reduce that is possible.



### Lamination dummy



Art. no.743Y42=24

The lamination dummy can be used with the alignment rod (article no. 743A18). Compatible with the Physolino baby hand.



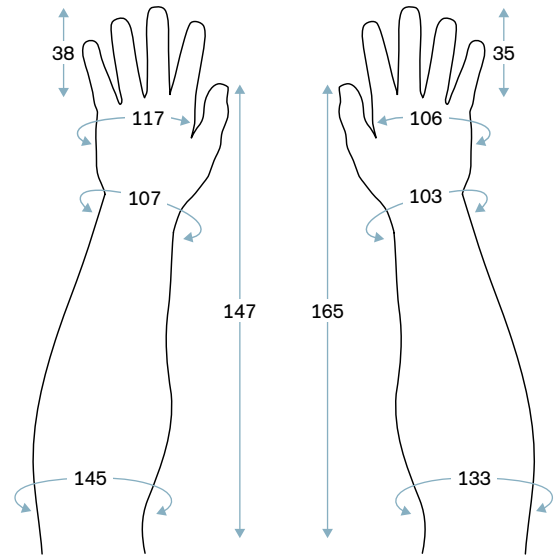



# ▶ Passive prosthetic hands for children

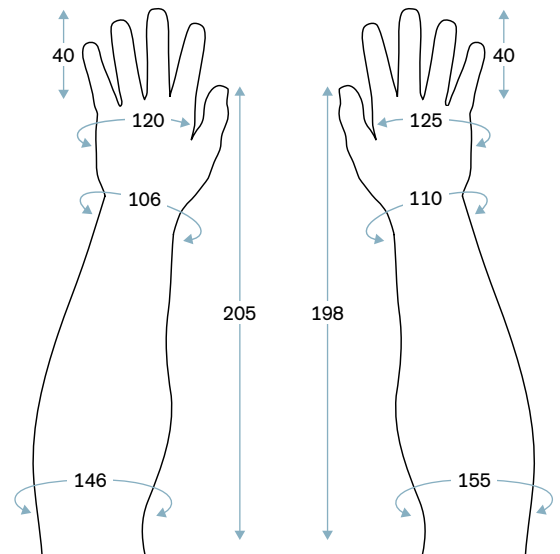

Side	Art. no.	Check no.	Art. no.	Side
	8S6=115X38L	40	8S6=115X37R	
	8S9=115X38L		8S9=115X37R	







Side	Art. no.	Check no.	Art. no.	Side
	8S6=130X51L	41	8S6=134X52R	
	8S9=130X51L		8S9=134X52R	

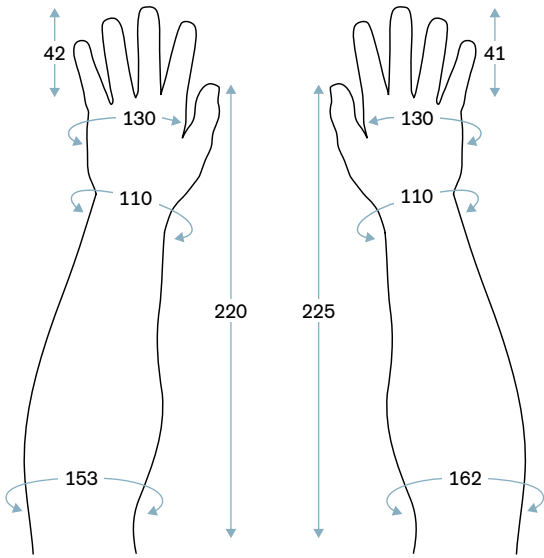





# ▶ Passive prosthetic hands for children

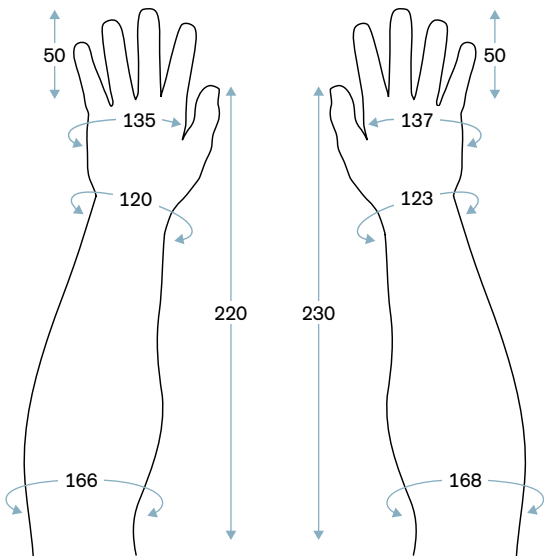





Side	Art. no.	Check no.	Art. no.	Side
	8S6=142X50L	42	8S6=139X51R	
	8S9=142X50L		8S9=139X51R	



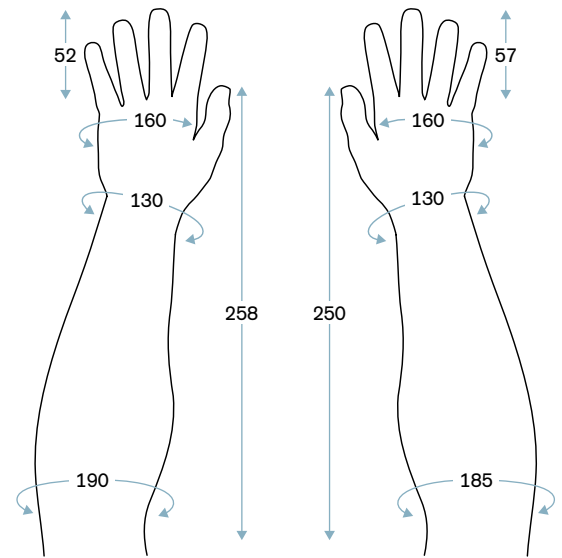



Side	Art. no.	Check no.	Art. no.	Side
	8S6=151X58L	44	8S6=151X59R	
	8S9=151X58L		8S9=151X59R	

## ▶ Passive prosthetic hands for children

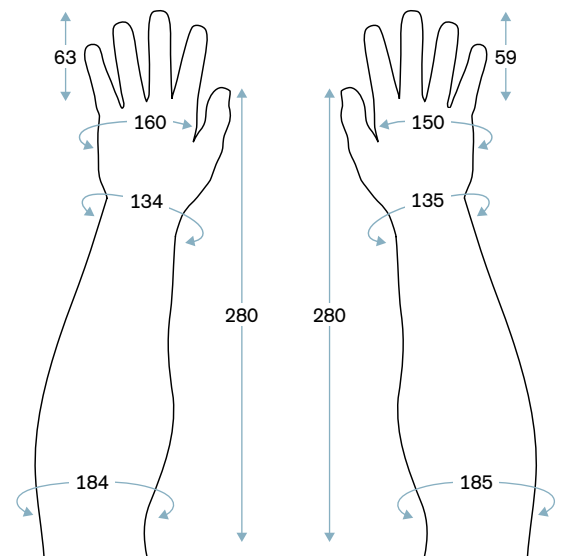





Side	Art. no.	Check no.	Art. no.	Side
	8S6=158X54L	86	8S6=159X53R	
	8S9=158X54L		8S9=159X53R	



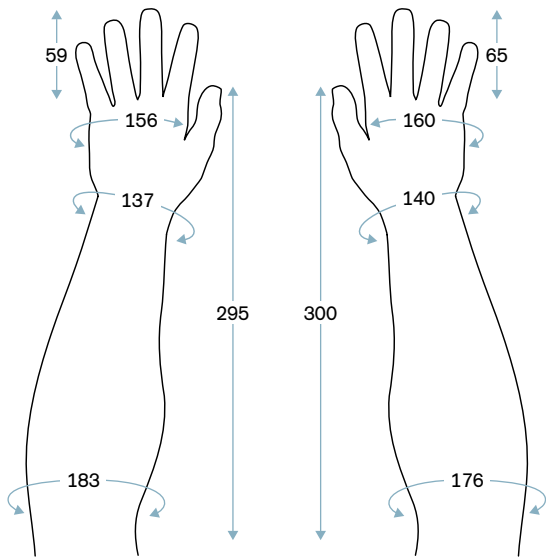



Side	Art. no.	Check no.	Art. no.	Side
	8S6=165X68L	48	8S6=158X68R	
	8S9=165X68L		8S9=158X68R	

# ▶ Passive prosthetic hands for children

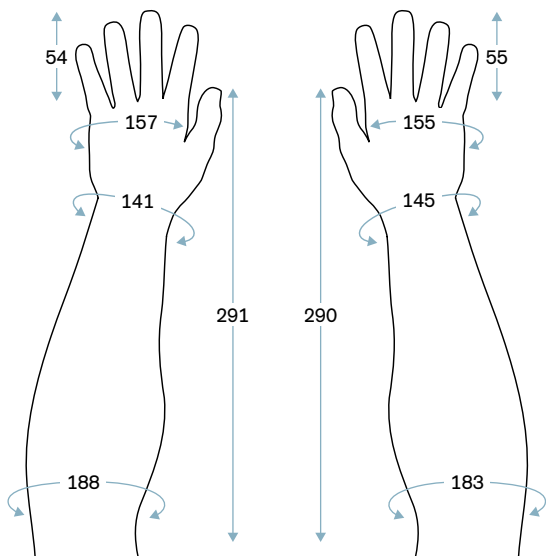





Side	Art. no.	Check no.	Art. no.	Side
	8S6=168X70L	47	8S6=166X70R	
	8S9=168X70L		8S9=166X70R	



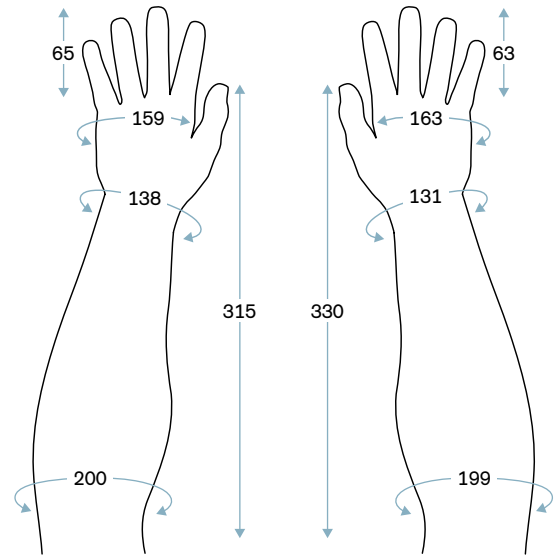



Side	Art. no.	Check no.	Art. no.	Side
	8S6=170X65L	43	8S6=170X65R	
	8S9=170X65L		8S9=170X65R	

## ▶ Passive prosthetic hands for women

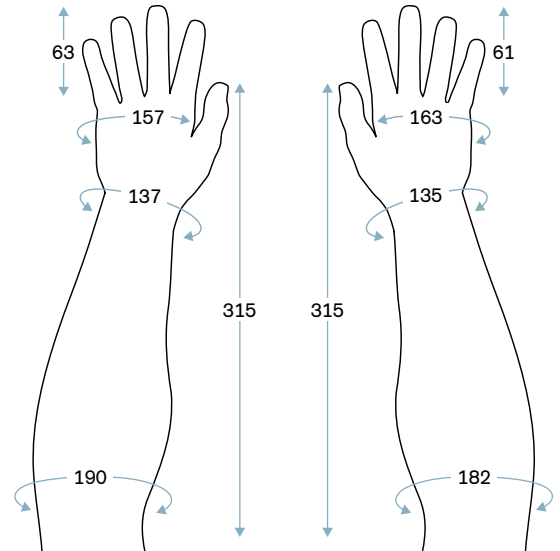





Side	Art. no.	Check no.	Art. no.	Side
	8S5=165X72L	34	8S5=167X72R	
	8S8=165X72L		8S8=167X72R	



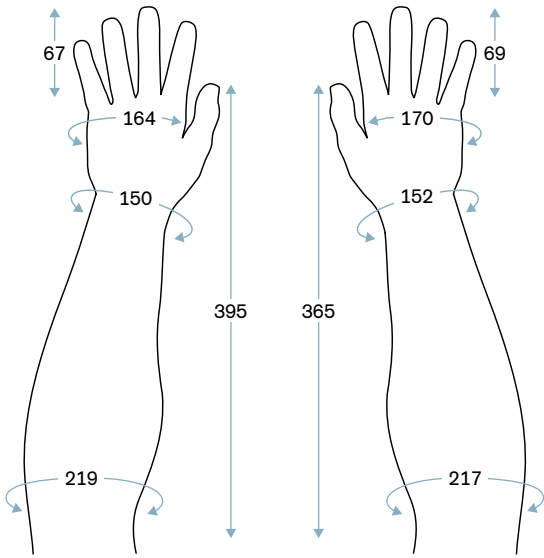



Side	Art. no.	Check no.	Art. no.	Side
	8S5=174X74L	32	8S5=175X76R	
	8S8=174X74L		8S8=175X76R	

# ▶ Passive prosthetic hands for women

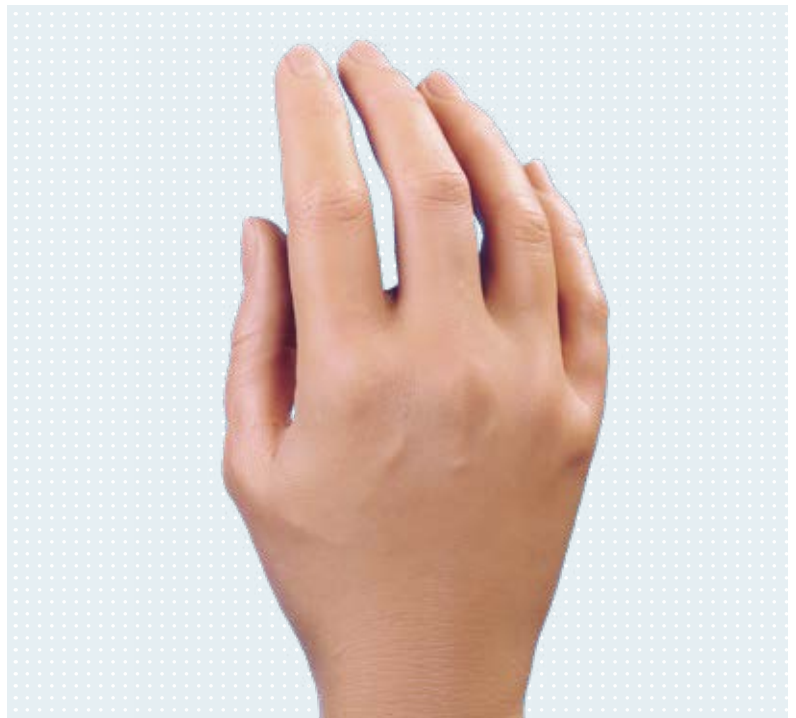
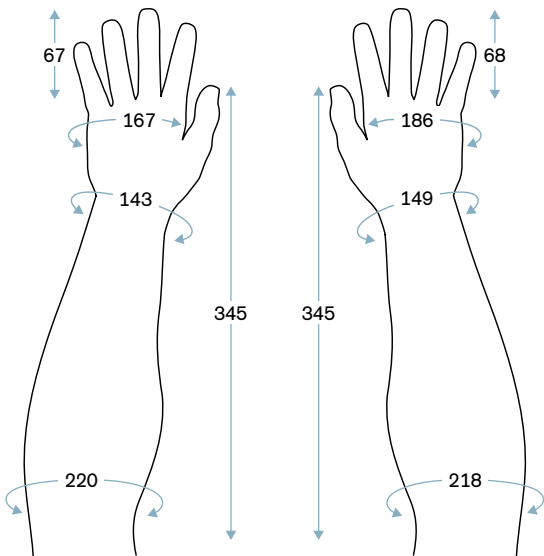

Side	Art. no.	Check no.	Art. no.	Side
	8S5=180X80L	29	8S5=176X80R	
	8S8=180X80L		8S8=176X80R	







Side	Art. no.	Check no.	Art. no.	Side
	8S5=182X84L	28	8S5=190X84R	
	8S8=182X84L		8S8=190X84R	

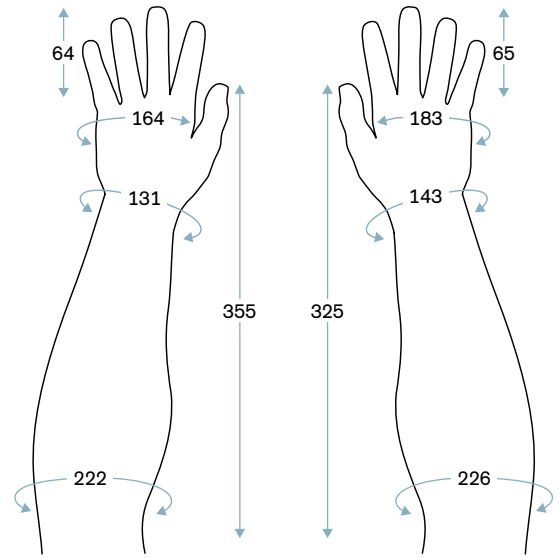





## ▶ Passive prosthetic hands for women

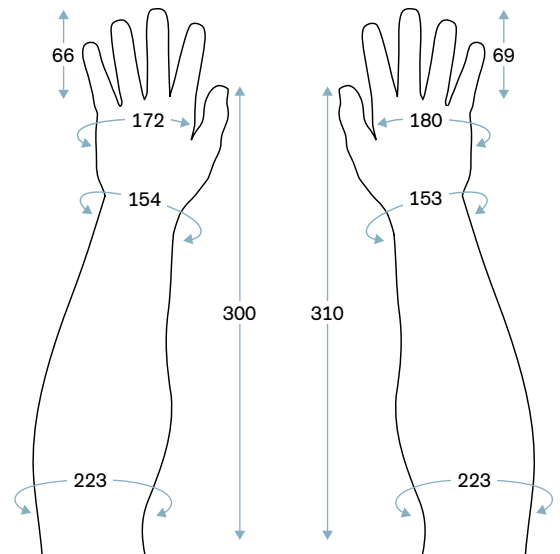

Side	Art. no.	Check no.	Art. no.	Side
	8S5=184X75L	36	8S5=187X74R	
	8S8=184X75L		8S8=187X74R	



Side	Art. no.	Check no.	Art. no.	Side
	8S5=184X78L	37	8S5=184X78R	
	8S8=184X78L		8S8=184X78R	



# ▶ Passive prosthetic hands for women

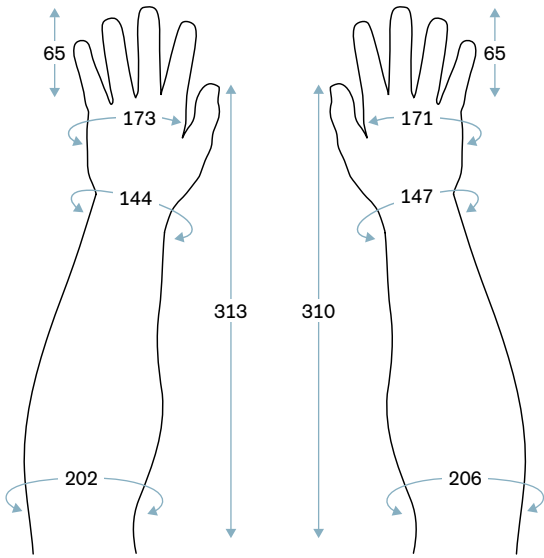

Side	Art. no.	Check no.	Art. no.	Side
	8S5=185X75L	23	8S5=181X75R	
	8S8=185X75L		8S8=181X75R	

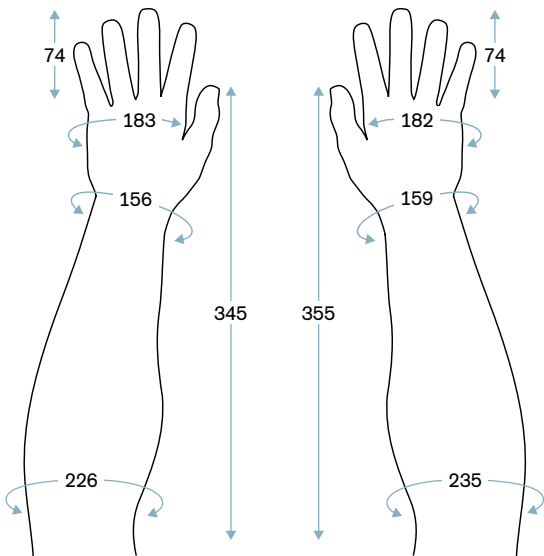



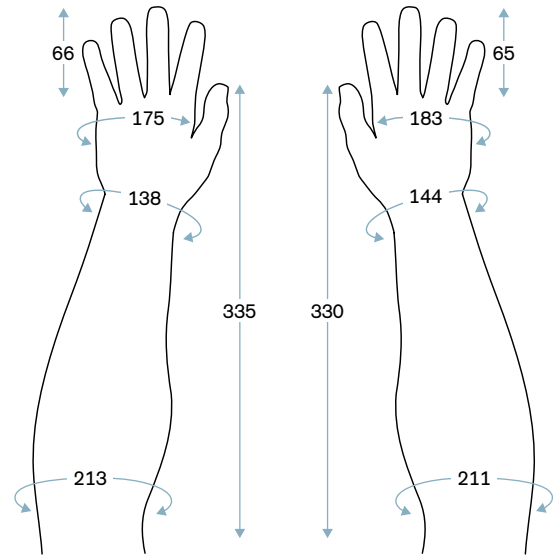

Side	Art. no.	Check no.	Art. no.	Side
	8S5=188X79L	70	8S5=187X79R	
	8S8=188X79L		8S8=187X79R	

## ▶ Passive prosthetic hands for women

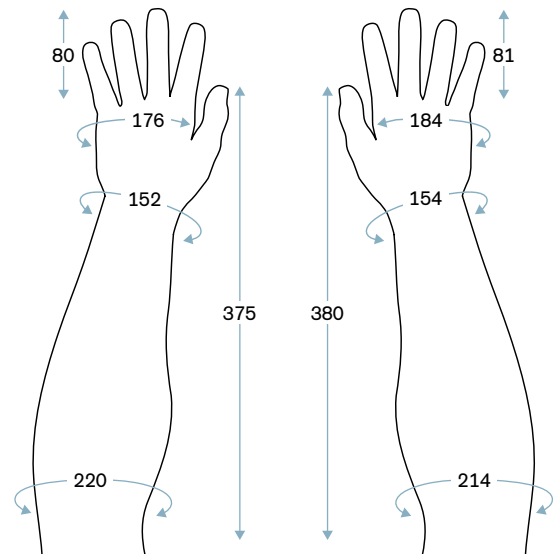
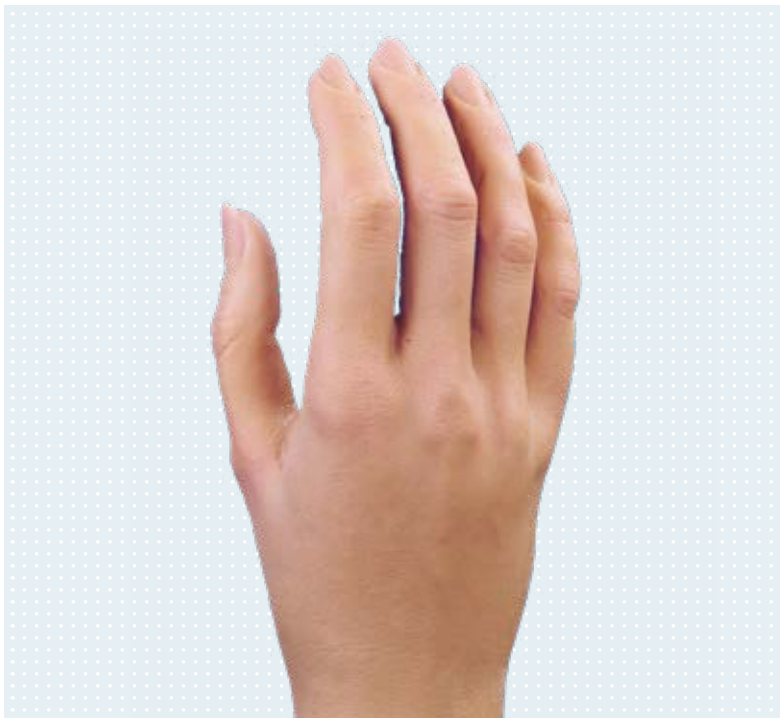

Side	Art. no.	Check no.	Art. no.	Side
	8S5=190X77L	20	8S5=190X77R	
	8S8=190X77L		8S8=190X77R	



Side	Art. no.	Check no.	Art. no.	Side
	8S5=190X93L	30	8S5=186X92R	
	8S8=190X93L		8S8=186X92R	

# ▶ Passive prosthetic hands for women

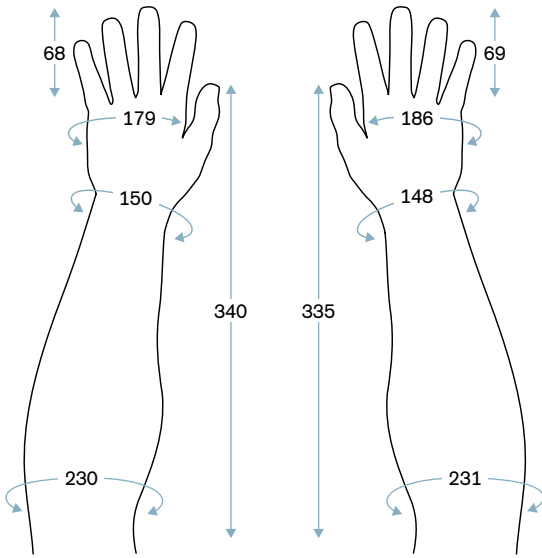



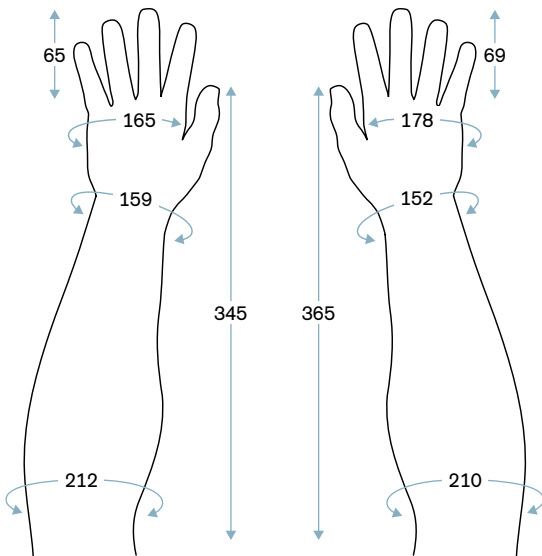

Side	Art. no.	Check no.	Art. no.	Side
	8S5=192X78L	24	8S5=191X78R	
	8S8=192X78L		8S8=191X78R	



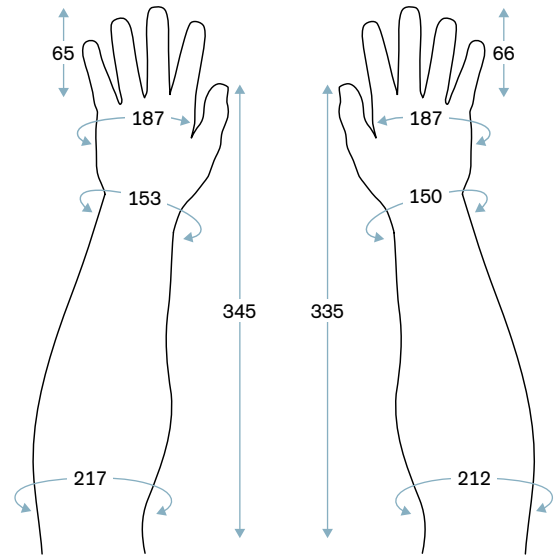



Side	Art. no.	Check no.	Art. no.	Side
	8S5=194X82L	27	8S5=189X84R	
	8S8=194X82L		8S8=189X84R	

## ▶ Passive prosthetic hands for women

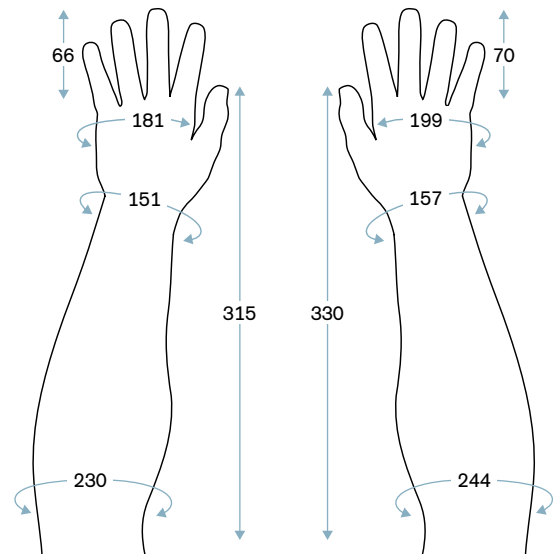





Side	Art. no.	Check no.	Art. no.	Side
	8S5=195X78L	38	8S5=195X78R	
	8S8=195X78L		8S8=195X78R	

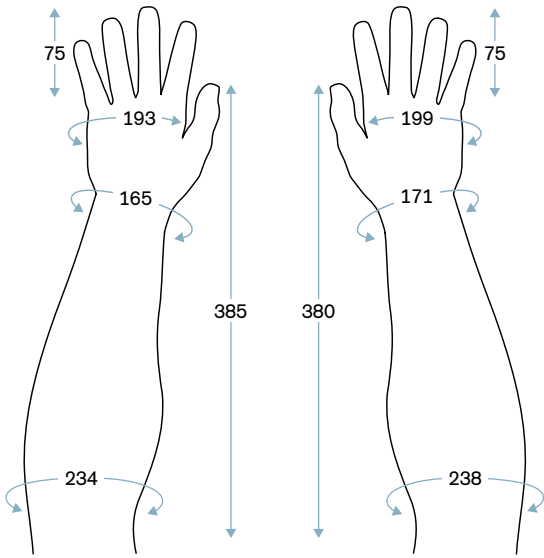

Side	Art. no.	Check no.	Art. no.	Side
	8S5=195X79L	25	8S5=200X79R	
	8S8=195X79L		8S8=200X79R	





## ▶ Passive prosthetic hands for women



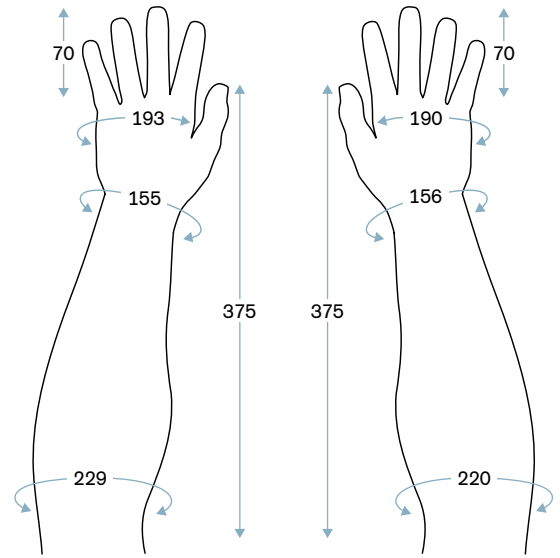



Side	Art. no.	Check no.	Art. no.	Side
	8S5=208X89L	19	8S5=210X89R	
	8S8=208X89L		8S8=210X89R	

## ▶ Passive prosthetic hands for men

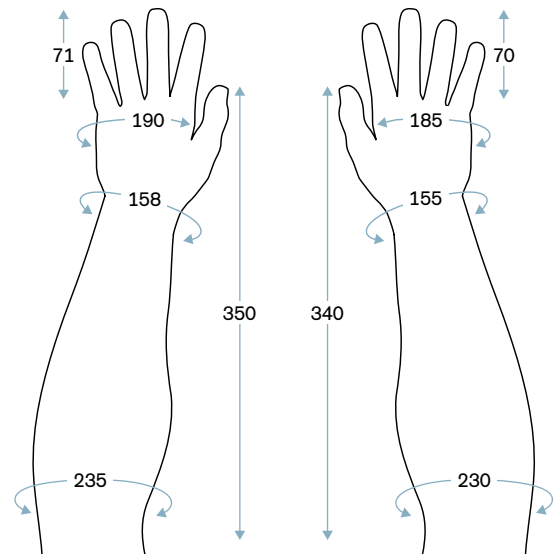

Side	Art. no.	Check no.	Art. no.	Side
	8S4=202X74L	58	8S4=206X76R	
	8S7=202X74L		8S7=206X76R	







Side	Art. no.	Check no.	Art. no.	Side
	8S4=203X83L	16	8S4=199X82R	
	8S7=203X83L		8S7=199X82R	

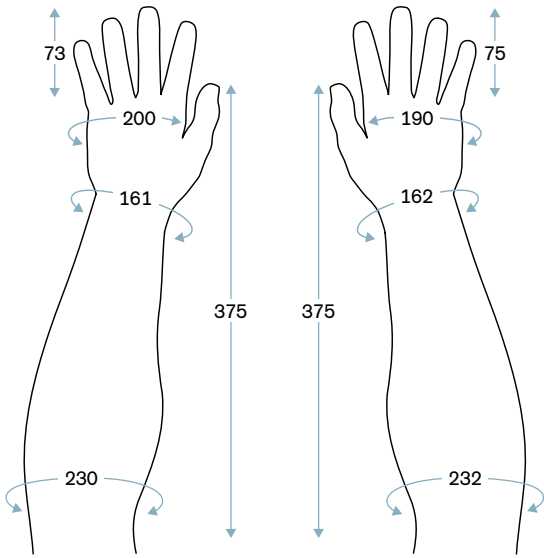





# ▶ Passive prosthetic hands for men

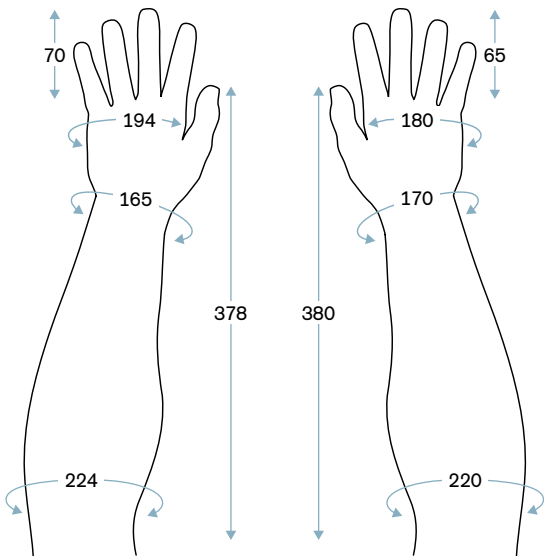





Side	Art. no.	Check no.	Art. no.	Side
	8S4=203X85L	15	8S4=206X85R	
	8S7=203X85L		8S7=206X85R	



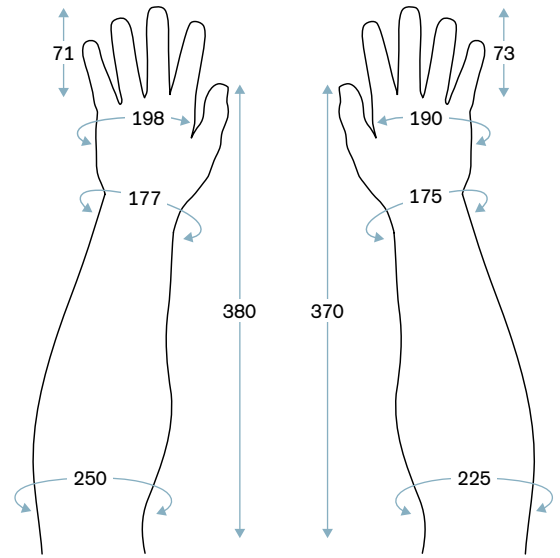



Side	Art. no.	Check no.	Art. no.	Side
	8S4=205X81L	5	8S4=205X81R	
	8S7=205X81L		8S7=205X81R	

## ▶ Passive prosthetic hands for men

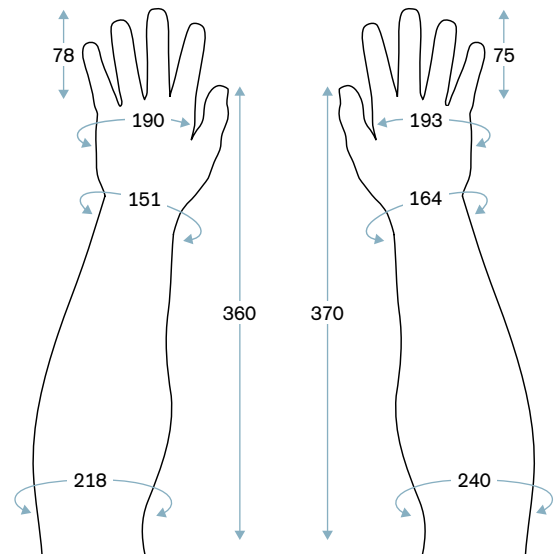
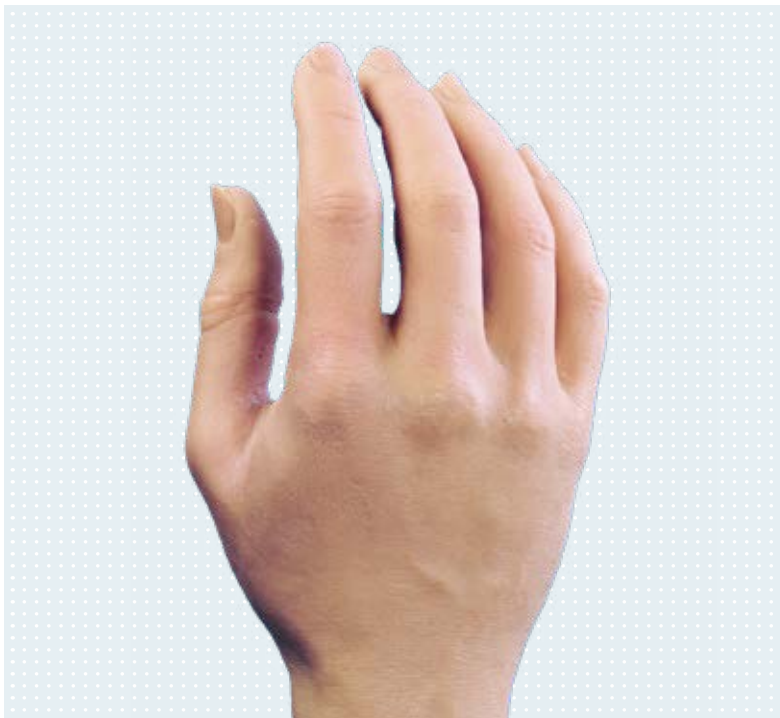





Side	Art. no.	Check no.	Art. no.	Side
	8S4=206X80L	60	8S4=205X80R	
	8S7=206X80L		8S7=205X80R	



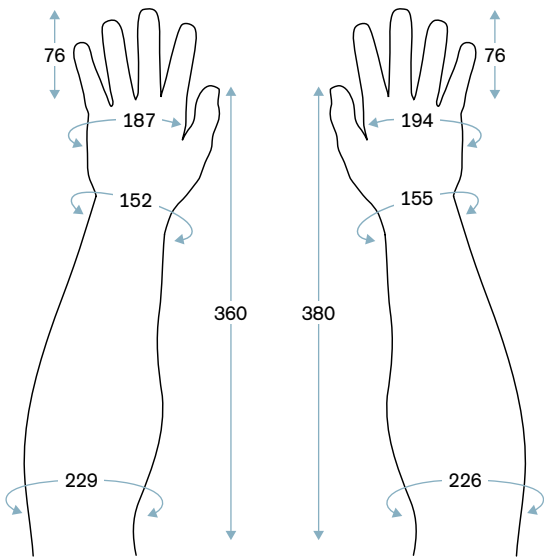



Side	Art. no.	Check no.	Art. no.	Side
	8S4=206X87L	13	8S4=215X88R	
	8S7=206X87L		8S7=215X88R	

# ▶ Passive prosthetic hands for men

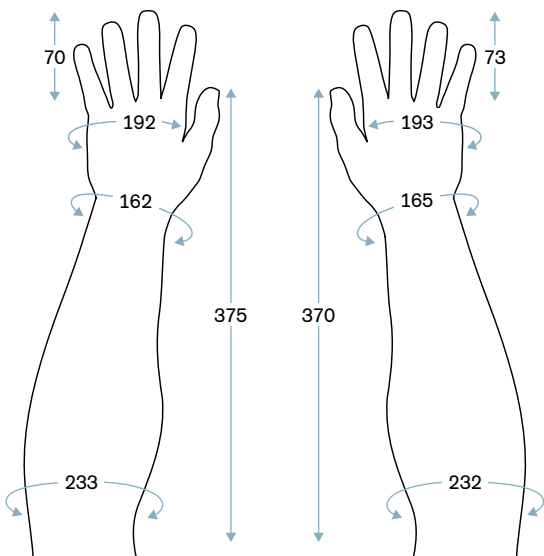





Side	Art. no.	Check no.	Art. no.	Side
	8S4=207X86L	57	8S4=209X86R	
	8S7=207X86L		8S7=209X86R	



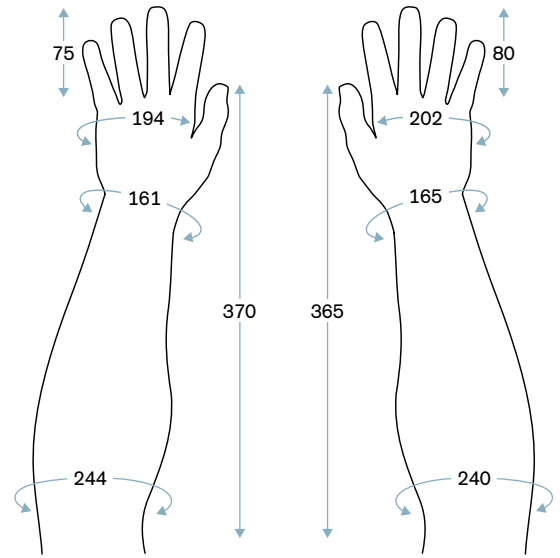



Side	Art. no.	Check no.	Art. no.	Side
	8S4=208X85L	12	8S4=212X83R	
	8S7=208X85L		8S7=212X83R	

## ▶ Passive prosthetic hands for men

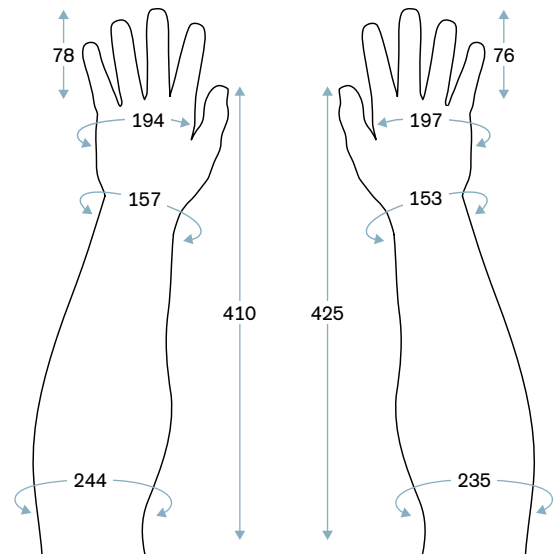

Side	Art. no.	Check no.	Art. no.	Side
	8S4=211X88L	59	8S4=212X86R	
	8S7=211X88L		8S7=212X86R	



Side	Art. no.	Check no.	Art. no.	Side
	8S4=212X93L	56	8S4=215X93R	
	8S7=212X93L		8S7=215X93R	

# ▶ Passive prosthetic hands for men

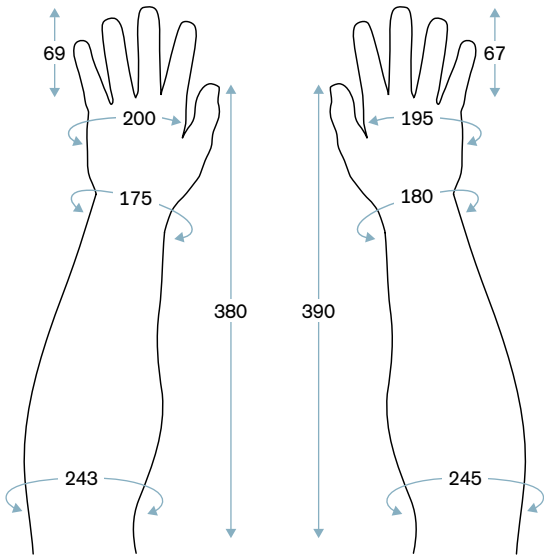

Side	Art. no.	Check no.	Art. no.	Side
	8S4=213X85L	54	8S4=218X85R	
	8S7=213X85L		8S7=218X85R	

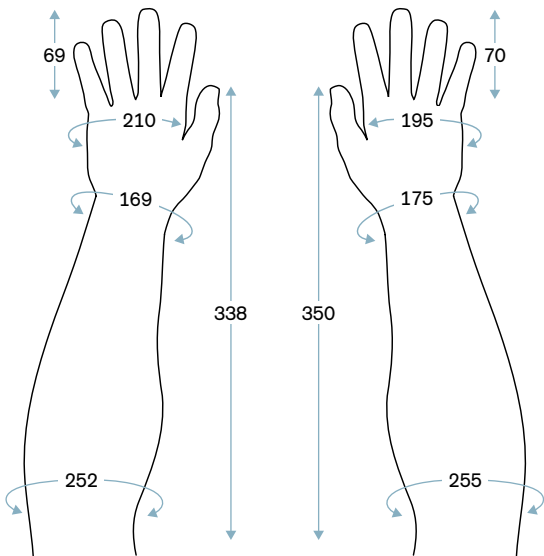





Side	Art. no.	Check no.	Art. no.	Side
	8S4=214X82L	17	8S4=215X83R	
	8S7=214X82L		8S7=215X83R	

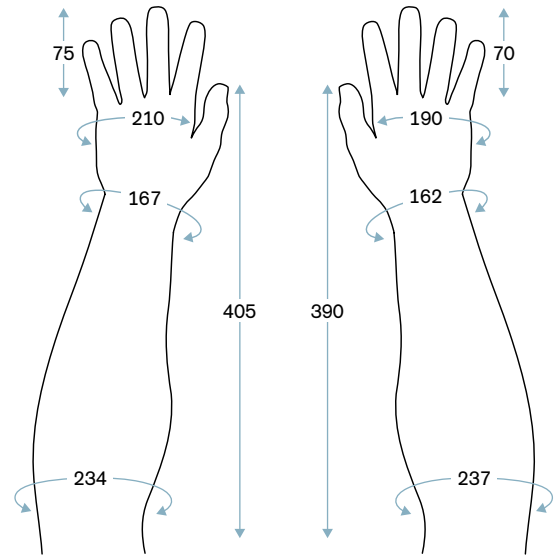





## ▶ Passive prosthetic hands for men

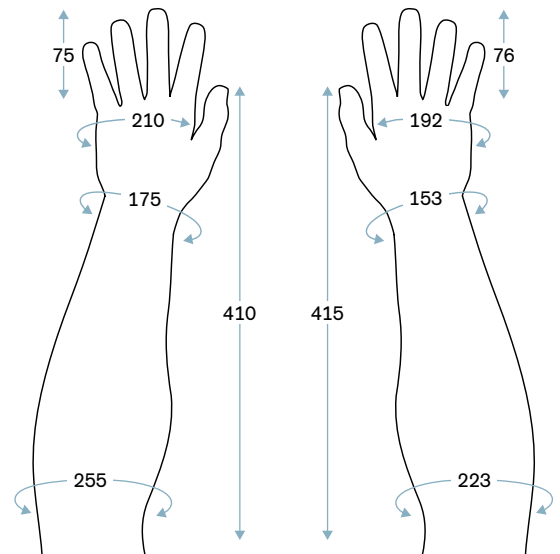

Side	Art. no.	Check no.	Art. no.	Side
	8S4=218X85L	8	8S4=218X83R	
	8S7=218X85L		8S7=218X83R	



Side	Art. no.	Check no.	Art. no.	Side
	8S4=220X91L	11	8S4=214X90R	
	8S7=220X91L		8S7=214X90R	



# ▶ Passive prosthetic hands for men

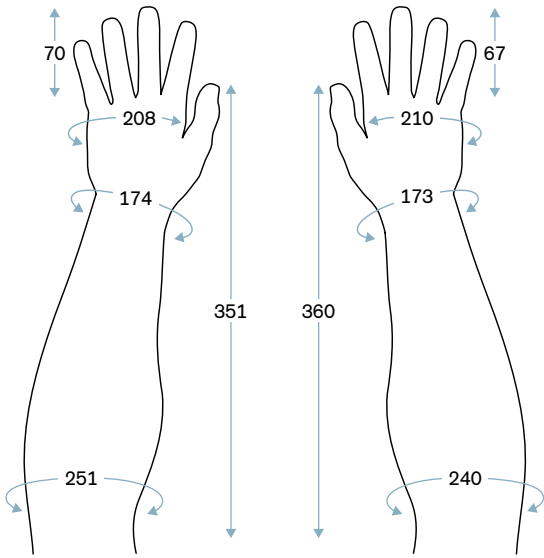



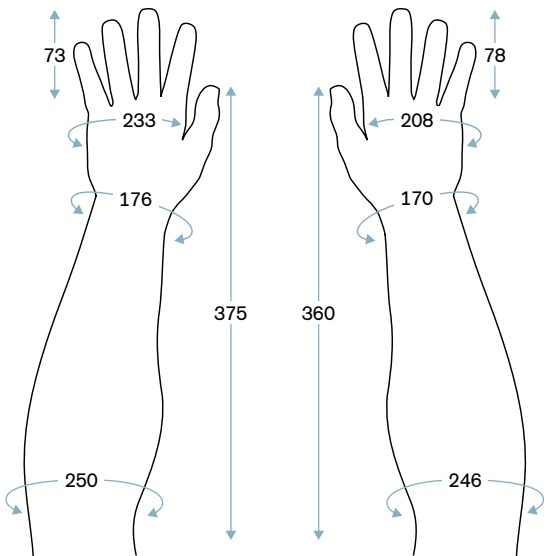

Side	Art. no.	Check no.	Art. no.	Side
	8S4=221X81L	51	8S4=225X82R	
	8S7=221X81L		8S7=225X82R	



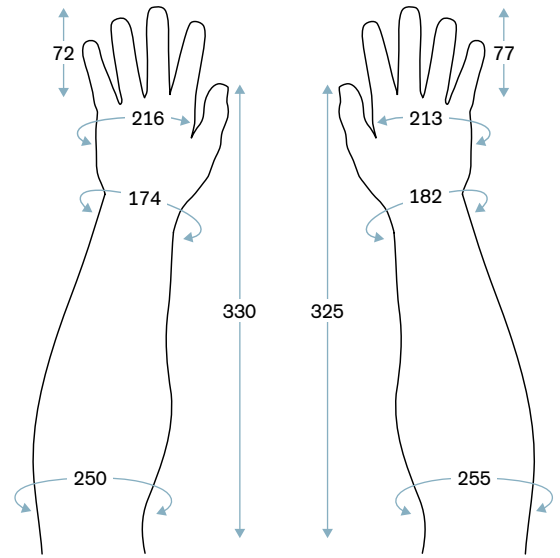



Side	Art. no.	Check no.	Art. no.	Side
	8S4=228X84L	53	8S4=222X84R	
	8S7=228X84L		8S7=222X84R	

## ▶ Passive prosthetic hands for men

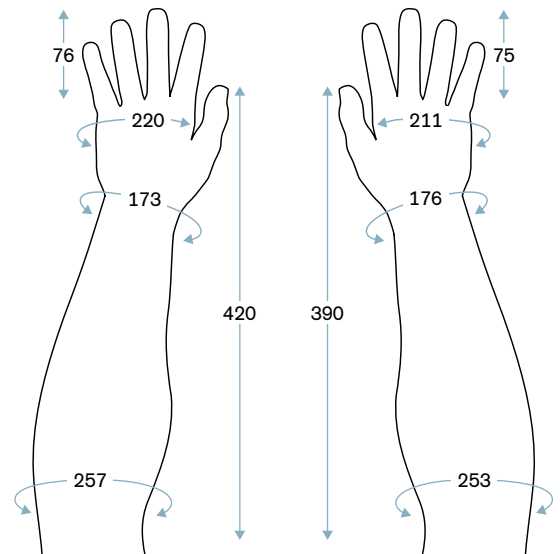





Side	Art. no.	Check no.	Art. no.	Side
	8S4=228X88L	52	8S4=228X89R	
	8S7=228X88L		8S7=228X89R	

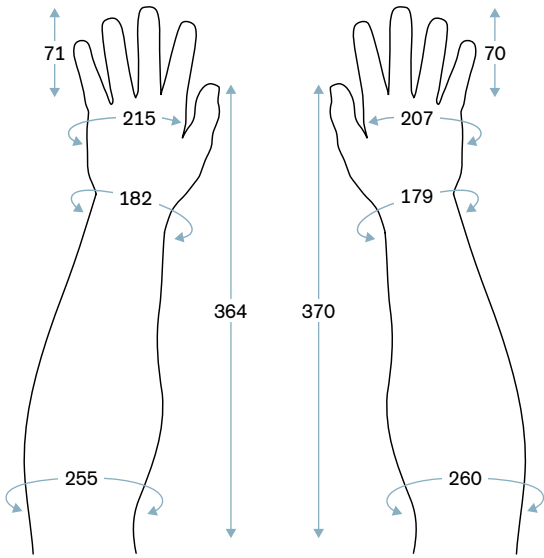

Side	Art. no.	Check no.	Art. no.	Side
	8S4=232X94L	55	8S4=230X93R	
	8S7=232X94L		8S7=230X93R	

# ▶ Passive prosthetic hands for men



Side	Art. no.	Check no.	Art. no.	Side
	8S4=238X92L	14	8S4=244X94R	
	8S7=238X92L		8S7=244X94R	

## ▶ Arm components



647G471

### Transhumeral modular kit

Art. no.12R6

The modular structural component set contains the components for an upper arm prosthesis. Suitable for short and long above-elbow residual limbs with passive elbow lock as well as upper arm and forearm rotation.

#### Key features at a glance

- Passive elbow lock
- Upper arm and forearm rotation
- Tubes can be individually shortened in the defined range
- Article no. 13R6 for long residual limbs included

Art. no.	Side
12R6=L	Left (L)
12R6=R	Right (R)



647G471

### Shoulder disarticulation modular kit

Art. no.12R7

The modular structural component set contains the components for a prosthesis for shoulder disarticulation fitting with passive elbow locking.

#### Key features at a glance

- Passive elbow lock
- Upper arm and forearm rotation
- Tubes can be individually shortened in the defined range
- Adapter (article no. 13R7 for 12S4) included

Art. no.	Side
12R7=L	Left (L)
12R7=R	Right (R)

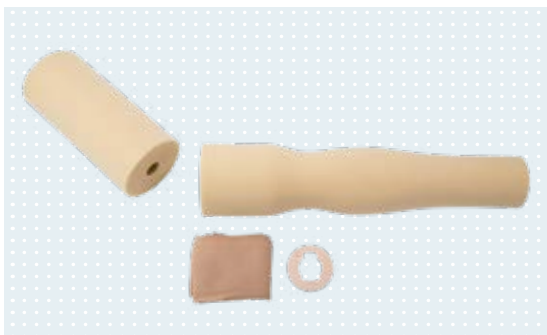

### Foam modular kit

Art. no.15K10

The foam modular kit is compatible with forearms with a circumference of 300 mm. Includes a perlon frizz stockinette (article no. 623T8=9), about 2 m long. Colour: beige. The 13R8=64 connection flange is also included.

## ▶ Arm components

### Flexion cable retainer

Art. no.13Y1

Flexion cable retainer for forearm tube.



### Connection disc with groove

Art. no.13R9

Connection disc with groove for attaching the perlon frizz stockinette to the wrist joint.

Art. no.	Exterior diameter	Size
13R9=45	45 mm	6¾
13R9=50	50 mm	7¼
13R9=55	55 mm	7¾ and 8
13R9=65	65 mm	Passive prosthetic hands, adaptable



## ► Shoulder joints and accessories

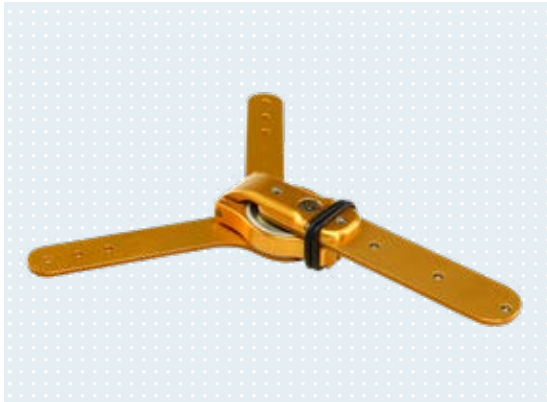

 647G349



### Tip

- This joint can also be fitted in conjunction with the DynamicArm (article no. 12K100N and 12K110N).

## MovoShoulder Swing

Art. no.12S6

This shoulder joint opens up new possibilities for prosthetic fittings in the shoulder area. The MovoShoulder Swing is ideal for prostheses with basic functions or in combination with high-tech components. The free swing of up to 40° reduces pressure from the prosthetic socket and allows even bilateral amputees to achieve natural, harmonious movements. Locking at 30° anteversion and unlocking is controlled by specific upper body movements or with the sound hand. No additional control elements such as switches or a body harness are required. Abduction of up to 20° facilitates more comfortable movement patterns during many activities of daily life. This applies in particular to activities done close to the body or while sitting.

Art. no.	Side
12S6=L	Left (L)
12S6=R	Right (R)

### Technical data

Overall length	230 mm
Weight	242 g

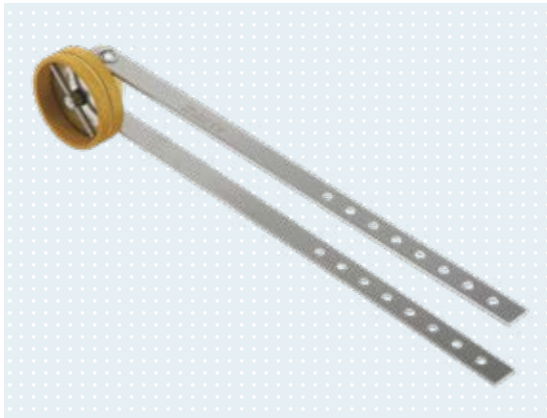

 647G473

## Shoulder joint

Art. no.12S4

This shoulder joint has two axes with separate friction and two arm bars.

### Technical data

Overall length	220 mm
Lamination ring diameter	43 mm
Weight	134 g



 647G473

## Ottobock ball shoulder joint

Art. no.12S7

Ottobock ball shoulder joint with threaded stud M12X1.5 (weight: 78 g).



## ▶ Shoulder joints and accessories

### Lamination ring

Art. no.13Z16=43

Spare part for Ottobock shoulder joint article no. 12S4.



### Shoulder bracket set

Art. no.13D2

Art. no.	Side	Compatible with
13D2=L	Left (L)	12S6=L
13D2=R	Right (R)	12S6=R

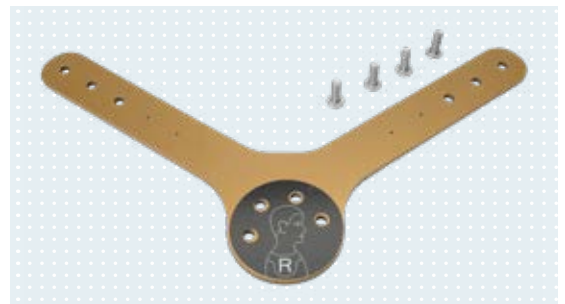

### O-ring set

Art. no.13D1

Spare part for MovoShoulder Swing shoulder joint article no. 12S6.

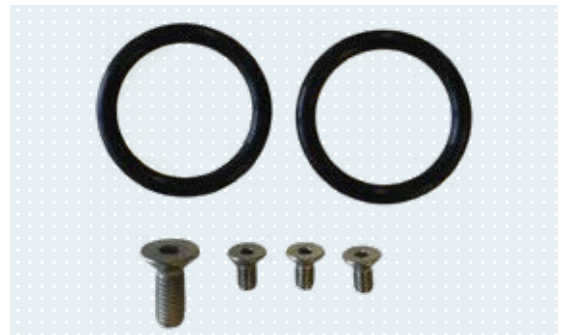

## ▶ Shoulder joints and accessories



### Modular elbow joint

Art. no.13R1

Modular elbow joint with passive lock.

Art. no.	Side
13R1=L	Left (L)
13R1=R	Right (R)

647G471



### Light metal piping

Art. no.13R3

Gold anodised light metal piping with a length of 250 mm, with reinforced ring and glide bushing.

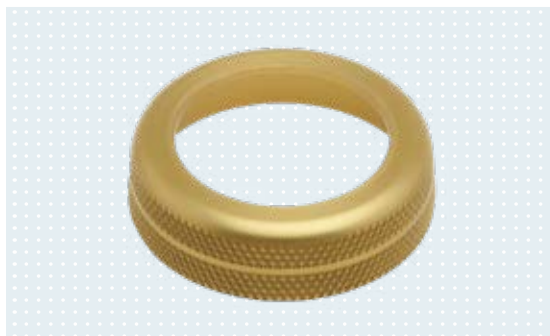

### Lamination ring

Art. no.13G8=67

Lamination ring with an exterior diameter of 67 mm. Compatible with article no. 12K5, 12K20 and 12R6.



### Truss head screw

Art. no.501S35=M4X6

Truss head screw for article no. 12R6, 12R7, 13R5, 13R6 and 13R7.

## ▶ Shoulder joints and accessories

### Cap screw

Art. no.501Z2=M4X18

Cap screw for article no. 12R6, 12R7 and 13R5.



### Adapter

Art. no.10R5

Adapter to connect the tubes (article no. 13R3/13R4) and adapter (article no. 13R6/13R7) to the elbow joint. For hand and upper arm rotation.



### Set screw

Art. no.506G1=M6X10

Set screw for article no. 10R5, 12R6 and 12R7.



### Joint ball

Art. no.13X5

Spare part for Ottobock ball shoulder joint article no. 12S7.

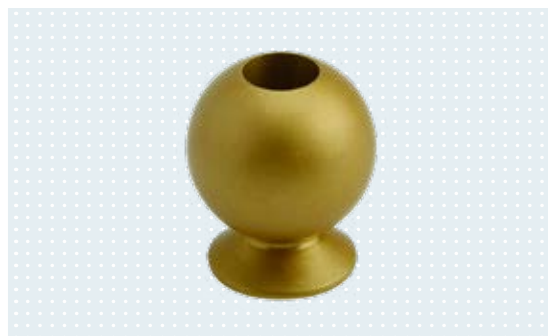

## ▶ Shoulder joints and accessories

---



### Joint clamp

Art. no.13X4

Spare part for Ottobock ball shoulder joint article no. 12S7.



### Friction ring

Art. no.13X3

Spare part for Ottobock ball shoulder joint article no. 12S7.



### Adapter

Art. no.10R2=M12X1.5

Adapter to connect modular arm components to the ball shoulder joint (article no. 12S7) with interior thread M12X1.5.

 647G454

## ▶ Shoulder joints and accessories

### Light metal piping

Art. no.13R4

Gold anodised light metal piping with reinforced ring and glide bushing (length: 120 mm).



### Adapter

Art. no.13R6

Adapter to connect lamination ring (article no. 13G8) and elbow joint by way of the adapter article no. 10R5.



## ▶ Elbow joint bars

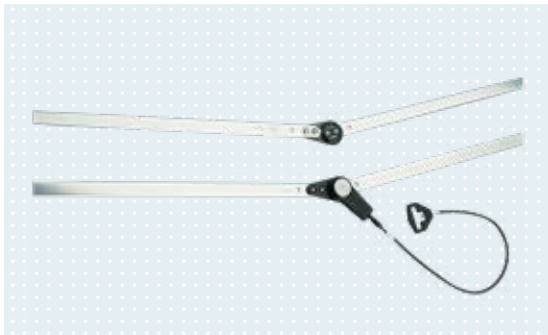

647G472

### Elbow joint bars

Art. no.16X12

Elbow joint bar with a bar and swivelling cable lock, 18 locking positions, each 7.2°. The second bar has no lock, flat bar profile, bars usable bilaterally, for orthoses and prostheses. Head diameter 30 mm, joint bar length 320 mm (top and bottom), joint bar width/thickness: 14/2 mm.

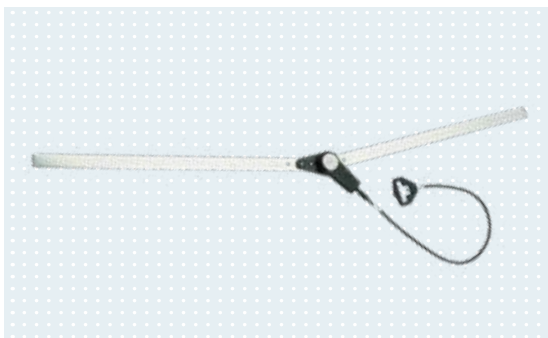

647G472

### Elbow joint bar with cable lock

Art. no.16X13

Joint with swivelling cable lock, 18 locking positions, each 7.2°, usable bilaterally, for orthoses and prostheses.

Head diameter 30 mm, joint bar length 320 mm (top and bottom), joint bar width/thickness: 14/2 mm.

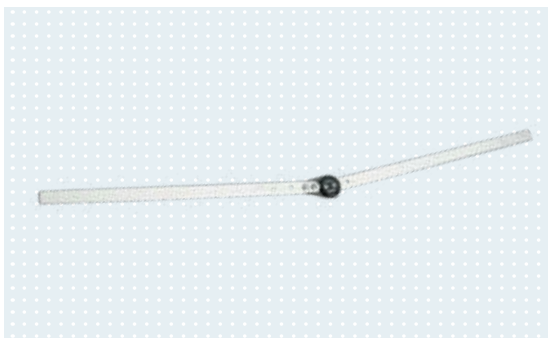

647G472

### Elbow joint bar without cable lock

Art. no.16X14

The joint is freely moveable with a flat joint bar profile.

Head diameter 30 mm, joint bar length 320 mm (top and bottom), joint bar width/thickness: 14/2 mm.



## ▶ Elbow joint bars

### Joint piece with cable lock

Art. no.16Y27

Joint piece with cable lock. 18 locking positions in 7.2° increments, suitable for both sides. With joint bracket and socket screws (oval head screws). Compatible with article no. 12K27, 16X12 and 16X13.



647G472

### Joint piece without lock

Art. no.16Y31

Joint piece without lock, compatible with article no. 16X12 and 16X14. With joint bracket and socket screws.



### Pull cable

Art. no.16Y26

Pull cable with screw connection, compatible with models article no. 12K27, 16X12 and 16X13.



### Belt flap

Art. no.21Y79

Belt flap with wedge lock compatible with models article no. 16X12 and 16X13.



## ▶ Liners and accessories

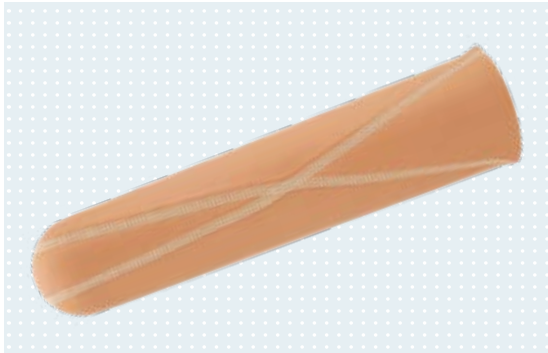

647G772

### IntoLiner Acclimate

Art. no.14Y3

The IntoLiner Acclimate, together with an custom fabricated frame socket, represents the connection between the residual limb and the arm prosthesis. Wearer comfort is improved by the breathable, moisture wicking and antibacterial textile material. It equalises heat and cold. In order to fully benefit from these features, we recommend fabricating a custom frame socket. An example can be found in the 646T3=3.5\* technical information. For fitting below-elbow residual limbs with a residual limb length of 10 cm and up.

#### Key features at a glance

- Temperature equalising
- Moisture wicking, breathable and antibacterial
- Available in various sizes
- Adjustable to the residual limb length
- Washable at 30° C



#### Measure correctly!

- For correct size selection, measure the circumference 3 cm proximal from the end of the residual limb. Subtract 1 to 2 cm from the measured circumference according to the soft tissue situation.

Art. no.	Length	Circumference 1
14Y3=140	290 mm	140 mm
14Y3=160	290 mm	160 mm
14Y3=180	290 mm	180 mm
14Y3=200	290 mm	200 mm
14Y3=220	290 mm	220 mm

- The colour of the liner corresponds approximately to the colour 4 of the Ottobock 646M3 colour scale for prosthetic gloves.

## ▶ Liners and accessories

### Skeo Up

Art. no.14Y5

The further development of the proven 14Y1 silicone ArmLiner, supplemented to include components of the Skeo family for lower limbs: Skeo Up. A non-adhesive outer coating was applied to this liner, eliminating the need for donning spray and making it much easier to put on and take off. The roughened interior contour also reduces the perception of perspiration and feels comfortable on the skin. The new matrix improves tear resistance by reducing longitudinal expansion. A pin is used to establish the connection to the lock built into the prosthetic socket.

#### Key features at a glance

- Suitable for residual limb sockets from a residual limb length of 100 cm on the upper arm and forearm
- Easier to put on and take off thanks to a special outer coating
- Very comfortable to wear due to roughened interior contour
- Highly robust thanks to new matrix
- New design

Art. no.	Length	Circumference 1	Circumference 2
14Y5=110	200 mm	110 mm	150 mm
14Y5=140	200 mm	140 mm	160 mm
14Y5=160	200 mm	160 mm	180 mm
14Y5=180	200 mm	180 mm	200 mm
14Y5=200	200 mm	200 mm	220 mm
14Y5=220	200 mm	220 mm	240 mm



647G323



#### Measure correctly!

- For correct size selection, measure the circumference 3 cm proximal from the end of the residual limb. Subtract 1 to 2 cm from the measured circumference according to the soft tissue situation.

### Lock set

Art. no.14A1

Lock set to secure a silicone ArmLiner (article no. 14Y1 and 14Y5) in the prosthetic socket.



647H347

### Donning spray

Art. no.640F18

The donning spray is needed among other things for donning and removal of the liner or prosthetic glove (silicone, PVC).

Art. no.	Contents
640F18	90 ml
640F18=900	900 ml (refill)



90 ml

900 ml

## ▶ Liners and accessories



### Derma Clean

Art. no.453H10

Derma Clean cleanses gently and reliably. It is pH-neutral, free of alkali and phosphates, and features an antibacterial formula.

Art. no.	Order by	Contents
453H10	6 bottles	300 ml
453H10=1	1 bottle	300 ml



### Derma Repair

Art. no.453H14

Derma Repair moisturises and promotes the regeneration of dry, sore skin. It reduces the effects of excessive strain and soothes irritated skin. Thanks to the antibacterial effect, it protects the skin against damaging external influences and makes it more resilient.

Derma Repair regulates moisture and makes the skin noticeably more supple and elastic. It also improves skin function by promoting the skin's blood circulation and supporting cell growth.

Art. no.	Order by	Contents
453H14	6 bottles	200 ml
453H14=1	1 bottle	200 ml



### Derma Prevent

Art. no.453H12

Derma Prevent is used for the prevention of chafing and inhibits contact with external allergens. It covers highly stressed skin with a protective coating and leaves it soft and supple.

It also inhibits perspiration and odour formation through the individual release of an active substance.

#### Key features at a glance

- For Polytol sockets
- Oily consistency
- Prevents static friction between socket and clothing

Art. no.	Order by	Contents
453H12	6 bottles	100 ml
453H12=1	1 bottle	100 ml



#### Measure correctly!

- To reduce the static friction of Polytol, rub a thin layer of Derma Prevent on the inside and outside of the socket. Do not apply Derma Prevent to those places where double-sided adhesive tape or a self-adhesive hook or loop strap will be attached later on.

## ▶ Liners and accessories

### Dummy set

Art. no.14A111

Dummy set for aligning a prosthesis with the silicone ArmLiner. The set consists of a pin dummy with and without thread and a shape dummy for the lamination ring.



### Pin

Art. no.14A107

The pin is available in various lengths.

Art. no.	Length
14A107	23 mm
14A107=1	28 mm
14A107=2	33 mm



### Lock with release pin

Art. no.14A110

Lock with release pin serves as a spare part for article no. 14A1.



## ▶ Body harnesses and accessories



647G1267=DE\_EN  
647G1279=DE\_EN

### Transhumeral soft harness

Art. no.21A47

Ottobock offers the world's first textile retaining support for upper arm prostheses with myoelectric or passive elbows. The support, consisting of an arm loop and a sleeve, is completely removable and not attached to the socket with a strap. Users can put it on and take it off with one hand. Soft underarm padding and breathable materials, which are fully washable, help make the harness comfortable. The back cord guide also allows the arms to swing naturally, supporting more physiological movement. The harness is available in three sizes for both the right and left arms. Users can also make small adjustments themselves using a hook-and-loop closure.

Size	Side	Back width	Armhole circumference
S	L/R	30–36.6 cm	38–45.3 cm
M	L/R	36.6–43.2 cm	45.3–52.6 cm
L	L/R	43.2–50 cm	52.6–60 cm

Order no.: article no.=side-size-colour. Order example: 21A47=L-S-1

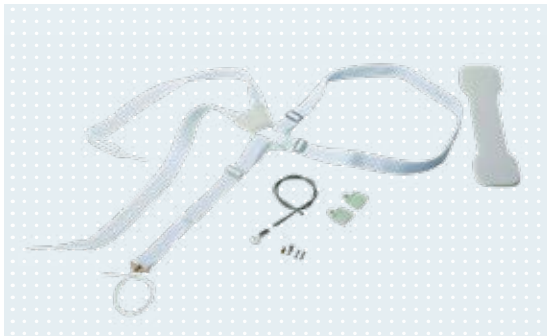

647H455

### Triple-control above-elbow harness

Art. no.21A35

The triple-control above-elbow harness is used to secure the prosthetic socket and for the control of body-powered prostheses. It is compatible with right and left-side devices.

Art. no.	Version
21A35=1	with perlon cable
21A35=2	with steel cable



647H455

### Below-elbow harness

Art. no.21A36

The below-elbow harness is intended for fixation of the prosthetic socket and for control of body-powered prostheses. It is compatible with right and left-side devices.

Art. no.	Version
21A36=1	with perlon cable
21A36=2	with steel cable



## ▶ Body harnesses and accessories

### Bowden cable

Art. no. 21A37=1

The Bowden cable is a spare part for article no. 21A35=1. Spiral length: 500 mm.



### Ball-shaft adapter

Art. no. 10Y31

The ball-shaft adapter with the coupler article no. 10Y32=\* is a connecting element.

Art. no.	Compatible with
10Y31=1	21A18=2 Perlon cable
10Y31=2	651D4=2 Steel cable
10Y31=7	3/64" steel cable
10Y31=8	1/16" steel cable
10Y31=9	3/32" steel cable



### Coupler

Art. no. 10Y32

The coupler with the ball-shaft adapter article no. 10Y31=\* is a connecting element.

Art. no.	Compatible with
10Y32=1	21A18=2 Perlon cable
10Y32=2	651D4=2 Steel cable

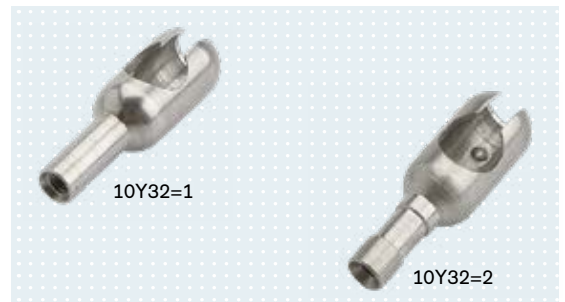

### Ring

Art. no. 21Y194

Harness ring with integrated cable guide.



## ▶ Body harnesses and accessories



### Stainless steel buckle

Art. no.21Y195=25

Stainless steel buckle for positioning and fixing the harness strap.



### Connecting bracket

Art. no.21Y197=1

Connecting bracket in white.

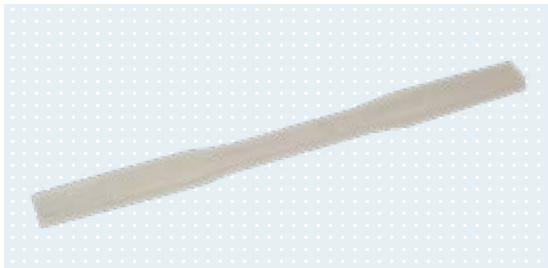

### Axillary protector for body harnesses

Art. no.21A29

Optional silicone axillary protector to ensure pleasant wearing comfort.

Art. no.	Width
21A29=18	18 mm
21A29=25	25 mm



### Axilla pad set

Art. no.21A38

Axilla pad set made of white foam. Contents: 5 pieces.

## ▶ Body harnesses and accessories

### Strap buckle

Art. no.21Y199

Strap buckle for a seamless connection of the elastic harness strap (article no. 623G23) to the prosthetic socket. Consisting of sleeve, lower part, upper part and spacer sleeve.

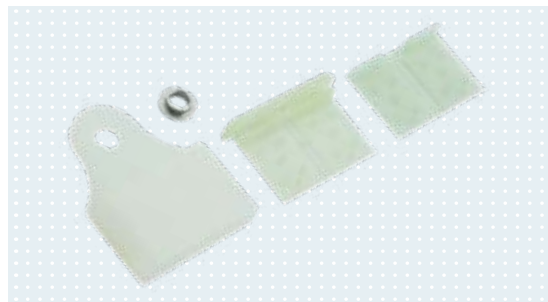

### Spacer sleeve

Art. no.21Y203

Spacer sleeve for strap buckle (article no. 21Y199).



### Socket screw with Allen head

Art. no.503F3

Socket screw (contents: 2 pieces) with Allen head. With M4 thread (length 7 mm). The head diameter is 8 mm.

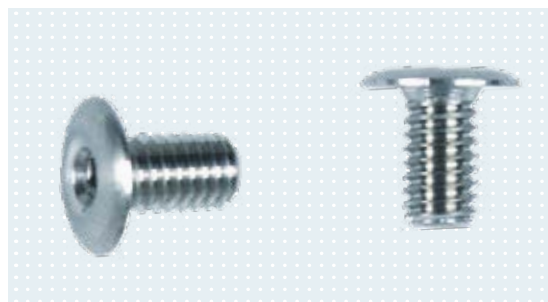

### Elastic harness strap

Art. no.623G23

Elastic harness strap in white with tunnel-shaped cable guide. Order by the metre



## ▶ Body harnesses and accessories



### Harness strap

Art. no.623H23

White harness strap. Order by the metre

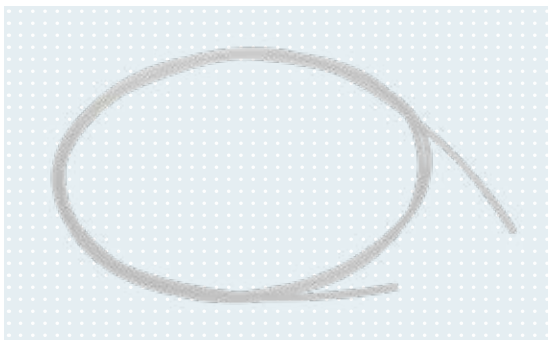

### Perlon cable

Art. no.21A18

Perlon cable with a diameter of 2 mm.

Art. no.	Length	Order by
21A18=2X1	1 m	linear metres
21A18=2X5	5 m	linear metres
21A18=2X10	10 m	linear metres
21A18=2X25	25 m	linear metres



### Setting nut

Art. no.29C5=MX4X9

Setting nut (knurled), stainless steel.

Art. no.	Thread	Length	Head diameter	Stud diameter
29C5=M4X9	M4	3.6 mm	9 mm	5.5 mm



### Cable clamp

Art. no.10Y3

## ▶ Body harnesses and accessories

### Clamp sleeve, short

Art. no.10Y25

The short clamp sleeve is used for crimping onto the steel cable (article no. 651D4=2).



### Clamp sleeve, long

Art. no.10Y26

The clamp sleeve is used for crimping onto the steel cable (article no. 651D4=2).



### Eyelet cable anchor, large

Art. no.21A5

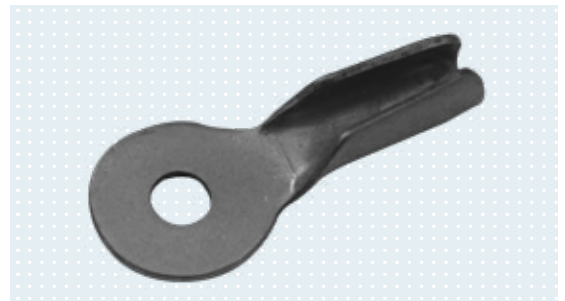

### Spiral nut

Art. no.21A6

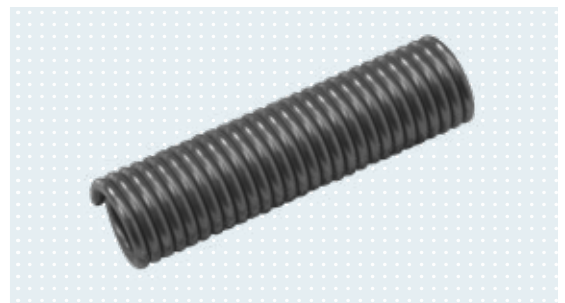

## ▶ Body harnesses and accessories

---



### Coupling piece

Art. no.21A7

Coupling piece for perlon cable.

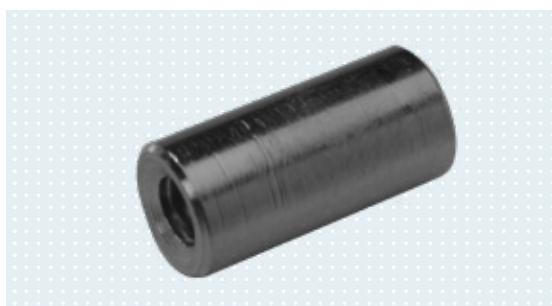

### Threaded sleeve, long

Art. no.21A11

The long threaded sleeve is screwed on the perlon cable (article no. 21A18=2) (content: 2 pieces).



### Threaded sleeve

Art. no.21A12

The short threaded sleeve is screwed on the perlon cable (article no. 21A18=2) (content: 2 pieces).

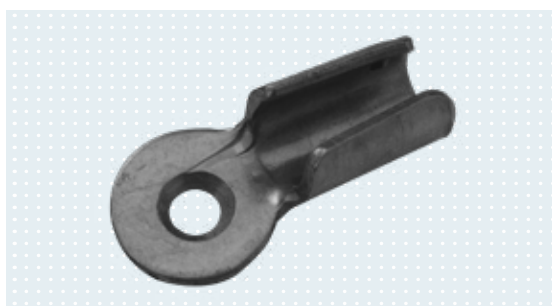

### Eyelet cable anchor, small

Art. no.21A24



## ▶ Body harnesses and accessories

### Spring

Art. no.21A25

Spring for coupling piece.

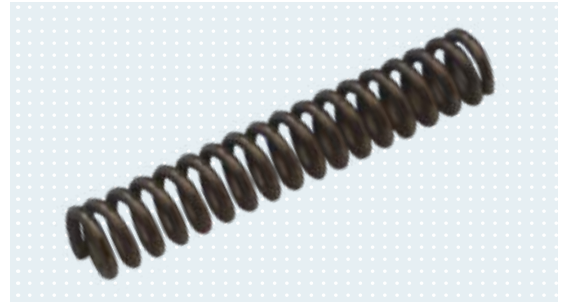

### Cable strap buckle

Art. no.21Y37

Cable strap buckle with a clearance width of 25 mm.



### Elastic double strap

Art. no.623G4

Elastic double strap for clip closure (article no. 29R127). In grey with white stripes. Washable up to 40 °C.

Art. no.	Length	Width
623G4=1	1 m	30 mm
623G4=5	5 m	30 mm



## ▶ Body harnesses and accessories

---

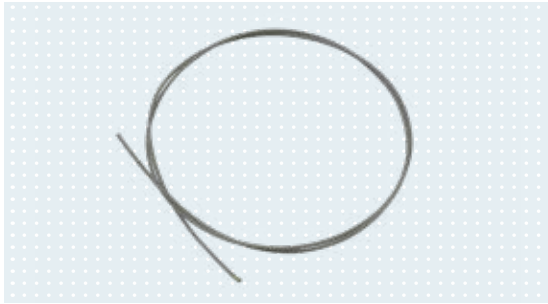

### Steel cable

Art. no.651D4=2

Steel cable with plastic cover.



### Countersunk head screw

Art. no.501S28=M3.5X5

Nickel-plated countersunk head screw for article no. 16H1 and 16H2.



### “D” ring

Art. no.21A16

“D” ring with a clearance width of 13 mm for flexion cable.



### Clamp buckle

Art. no.514K3=27

## ▶ Body harnesses and accessories

### Lamination disc, serrated

Art. no.507S15

Serrated lamination disc with bore (diameter: 3 mm). Exterior diameter 13.8 mm (contents: 2 pieces).



### Threaded support fastener

Art. no.516S3

Threaded support fastener with M4 thread and a thread length of 5.5 mm.

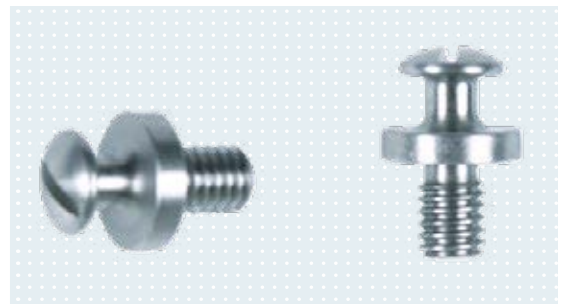

### Loop

Art. no.514Z3=25

Loop with a clearance width of 25 mm.



### Hollow rivet

Art. no.504H3=11-100

Hollow rivet with open lower part. Head diameter: 11 mm.



## ▶ Body harnesses and accessories



### Screw coupling

Art. no.10Y19=2

The screw coupling serves as a connection piece between a steel cable and perlon cable or spectra cable as well as between a perlon cable and perlon cable or spectra cable. Consists of coupling sleeve and coupling screw, which is screwed onto the perlon cable (article no. 21A18=\*) or through which a spectra cable is threaded and tied up.

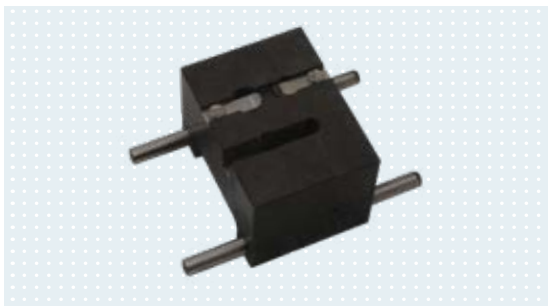

### Crimping tool

Art. no.736Y6

Crimping tool for crimping the coupling screw and clamp sleeve as well as the ball-shaft adapter (article no. 10Y31=2) and coupler (article no. 10Y32=2) onto the steel cable (article no. 651D4=2).

 647H13



### Sleeve protection pad

Art. no.15Y1

Rubber sleeve protection pad with leather cover.

Art. no.	Length	Width
15Y1=16	16 cm	85 mm
15Y1=18	18 cm	85 mm

# ▶ Notes

---

Series of horizontal dotted lines for writing notes.





# Special tools

**On the following pages you will find**

- Special tools
- Auxiliary materials



You can find our order forms  
in the download centre under

[www.ottobock.de/downloadcenter/](http://www.ottobock.de/downloadcenter/)

## ▶ Special tools



### Allen wrench

Art. no. 709S10=2

The Allen wrench is compatible with the socket screw, article no. 503F3.

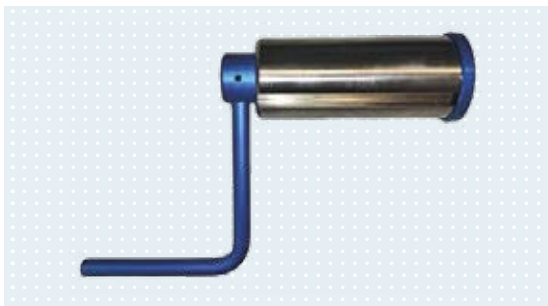

### Mounting wrench

Art. no. 711M18

The mounting wrench is used to accurately tighten the quick-disconnect mechanism (article no. 11S2) and to loosen disengaged ball bearings.



### Vacuum forming tool

Art. no. 711M53

Vacuum forming tool for arm prostheses with an exterior diameter of 260 mm.

• Only one vacuum forming tool is included in the scope of delivery!



### Conical drill bit (HSS)

Art. no. 726W9

Conical drill bit (HSS) suitable for processing plastic.

Art. no.	Diameter
726W9=14	14 mm
726W9=20	20 mm
726W9=30	30 mm

## ▶ Special tools

### Alignment tool for children's component

Art. no. 743A19

Alignment tool for children's component with an M8 thread (diameter: 12 mm, length: 169 mm). For 10S16 lamination rings.

#### Consisting of

- Alignment rod (article no. 743Y167)
- Lamination dummy for sizes 5 and 5½ (article no. 743Y42=34)
- Lamination dummy for sizes 6 and 6½ (article no. 743Y42=38)



### Alignment tool for adult component

Art. no. 743A18

Alignment tool for adult component with an M8 thread (diameter: 12 mm, length: 280 mm).

#### Consisting of

- Alignment rod (article no. 743Y41)
- Lamination dummy, 40 mm diameter (article no. 743Y42=40)
- Lamination dummy, 45 mm diameter (article no. 743Y42=45)
- Lamination dummy, 50 mm diameter (article no. 743Y42=50)
- Lamination dummy, 54 mm diameter (article no. 743Y42=54)

- When ordering spare parts, please specify the diameter (corresponds to the exterior diameter of the lamination ring, article no. 10S1).

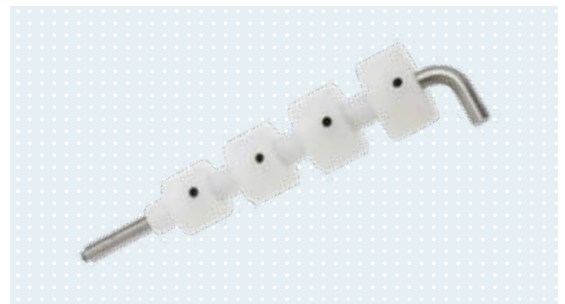

### Socket attachment piece

Art. no. 11S12

Socket attachment piece for fastening the alignment rod (article no. 743Y41) and for alignment of an upper limb prosthesis.



## ▶ Special tools

---

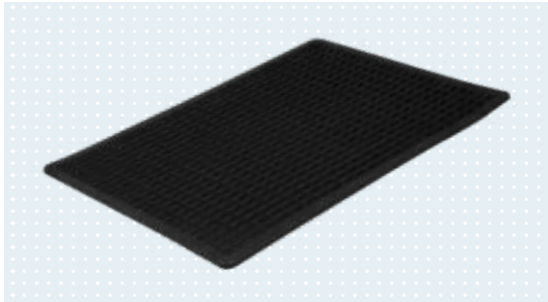

### Work mat

Art. no. 640Z6



### Universal pliers, small

Art. no. 706R4

The small universal pliers are 115 mm long.



### Side-cutting pliers

Art. no. 706Z2

Side-cutting pliers with oval head (head width: 10 mm). Length: 120 mm.



### Flat nose pliers

Art. no. 706F1=125

## ▶ Special tools

### Tweezers

Art. no. 799P1

Tweezers with a length of 120 mm.



### Tweezers

Art. no. 799P2

Tweezers with a length of 155 mm.

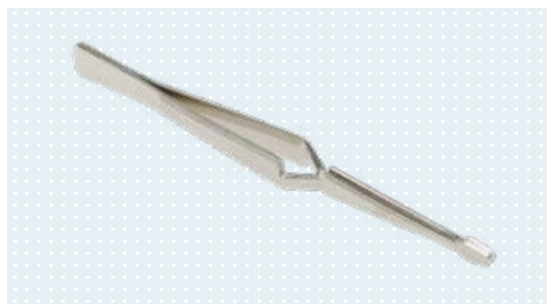

### Pliers

Art. no. 706Z10

Pliers for screwing the System Electric Hands (article no. 8E39) to the corresponding lamination ring. May also be used to loosen disengaged ball bearings in the quick-disconnect wrist unit.



### Precision screwdriver set

Art. no. 710H3

Precision screwdriver set with 1 / 1.5 / 1.8 / 2.3 / 2.9 and 3.6 mm blade widths.



## ▶ Special tools

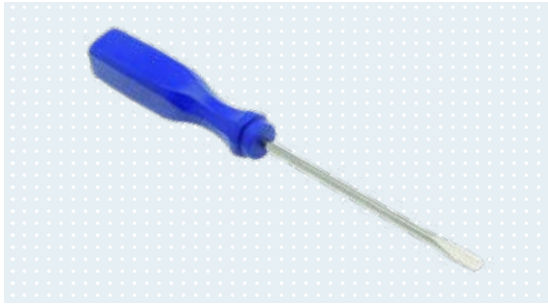

### Screwdriver

Art. no. 710H4

Screwdriver available in various blade widths.

Art. no.	Blade width
710H4=3	3.0 mm
710H4=4.5	4.5 mm
710H4=6	6.0 mm

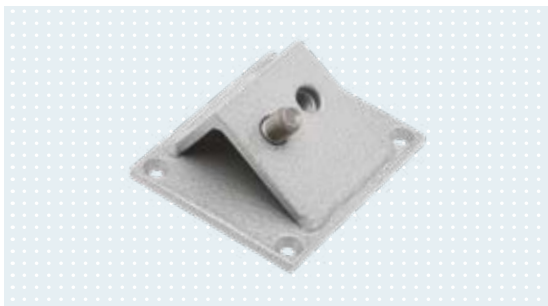

### Mounting plate

Art. no. 711M2

Mounting plate for screwing the mounting tool (article no. 711M1) to the workbench.



### Mounting tool

Art. no. 711M1

Mounting tool to hold the System Electric Hand. One side with M12X1.5 exterior thread (for prosthetic hands) and the other side with M12X1.5 interior thread (for Ottobock System Electric Hands and the Michelangelo hand).



### Mounting tool

Art. no. 711M3

Mounting tool to hold the System Electric Hand with quick-disconnect wrist unit.

#### Consisting of

- Coupling piece (article no. 10S4)
- Lock ring (article no. 11S4)
- Allen head screw (article no. 501Z2=M6X25)



## ▶ Special tools

### Mounting adapter for Michelangelo

Art. no. 711M64

The mounting adapter is essential for the correct application of the AxonSkin glove in order to protect the mechanism of the Michelangelo hand and for easier handling by the technician.

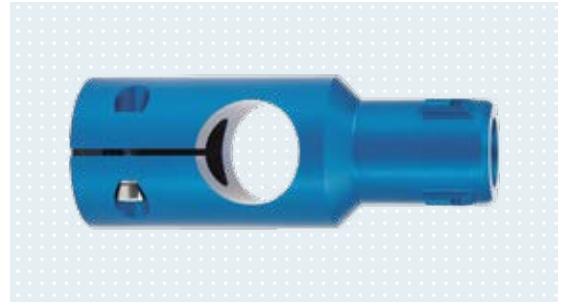

### Mounting aid

Art. no. 711M7

Mounting aid for attaching the System Electric Hands (article no. 8E39) to the mounting tool (article no. 711M1). Makes putting on and removing the inner hand and prosthetic glove easier.



### Mounting tool

Art. no. 711M16

Mounting tool for inserting the electric rotator (article no. 10S17) or coupling piece (article no. 10S4) into the lamination ring (article no. 10S1).



### Soldering jig

Art. no. 711M12

Soldering jig for soldering the cable connector (art. no. 9E167) to the coaxial bushing or the hand cable and for soldering the bushing plug to the motor.



## ▶ Special tools

---

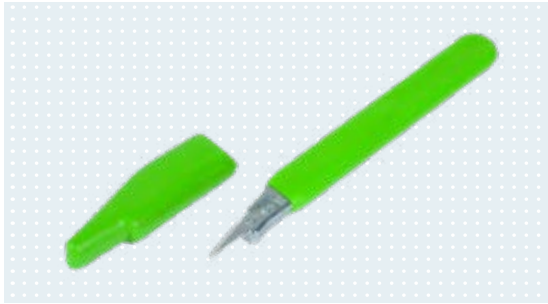

### Deburring knife

Art. no. 718H5

Deburring knife with replaceable blade. Plastic-coated with a length of 160 mm. For processing plastic, with protective cap and handle (weight: 0.05 kg).

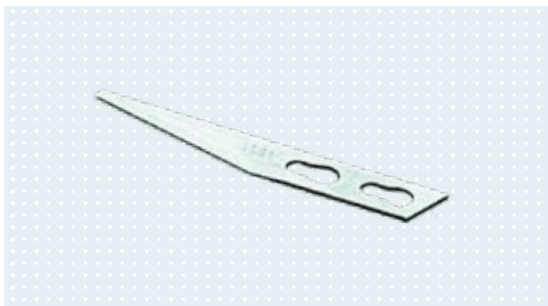

### Replacement blade

Art. no. 718Y1

Replacement blade for deburring knife, article no. 718H5 (weight: 1 g).



### Pinch gauge

Art. no. 743F1

Pinch gauge for checking the gripping force of System Electric Hands.

## ▶ Auxiliary materials

### Silicone grease 400, medium

Art. no. 633F11

Silicone grease for the planetary gear set of the drive unit as well as for all cable plug connections and other places that need to be protected to prevent penetration of perspiration. Can be used for plaster isolation (net contents: 100 g).

#### Application example

- Apply a pea-sized amount of silicone grease (article no. 633F11) to the wood spatula (article no. 699Y3).
- Prior to laminating, apply silicone grease to the objects that are to be isolated (e.g., thread of a screw, lamination dummy, adapter, orthotic joints).  
Attention: do not isolate those areas that are to create a bond with the lamination resin.
- Before laminating, carefully clean the bonded objects with isopropyl alcohol 6 (art. no 34A58).



### Special lubricant

Art. no. 633F14=\*

White special lubricant, Molycote-Paste DX suitable for all accessible gear wheels and axles in System Electric Hands and System Electric Greifers.

Art. no.	Delivery	Net contents
633F14=0.050	Tube	50 g
633F14=1	Can	1 kg



### Procomfort Gel

Art. no. 633S2

The gel acts as a lubricant, making the liner or prosthetic glove easier to put on over the inner hand (net contents: 250 ml).



## ▶ Auxiliary materials



### Isopropyl alcohol

Art. no. 634A58

Isopropyl alcohol (transparent) for cleaning sensitive plastics such as PVC, PS, ABS, acrylic, PC (net contents: 1 litre).

 646F297=D



### UHU-plus endfest 300

Art. no. 636W23

UHU-plus endfest 300, the two-component adhesive for strong adhesions.

 646F297=D



#### Tip

- The higher the curing temperature (up to approximately +180°C (+356°F)), the higher the strength of the adhesion.
- Using a measuring cup (article no. 642B2) has proven useful for mixing.
- Can be applied with the wood spatula, art. no. 699Y3.

## ▶ Auxiliary materials

### Loctite 243

Art. no. 636W60

Loctite 243 is used as thread lock for the electric hand, also hardens on brass, up to M36 thread (net contents: 50 ml). Can be activated and loosened by applying heat.



### Cyamet quick-drying adhesive

Art. no. 636K11

Cyamet quick-drying adhesive (transparent superglue) for adhering silicone rubber to acrylic resin laminates (net contents: 20 g).



646F297=D



### Loctite 241

Art. no. 636K13

Can be activated and loosened by applying heat (net contents: 50 ml).



### Loctite 601

Art. no. 636K14

Loctite 601 for locking the stud (net contents: 50 ml). Can be activated and loosened by applying heat.



## ▶ Auxiliary materials



### Special cleaner

Art. no. 640F12

In case of heavy soiling, the special cleaner for prosthetic gloves should be applied immediately (net contents: 460 g).



### Pump sprayer

Art. no. 640F13

The user should always keep a pump sprayer filled with special cleaner for Ottobock prosthetic gloves handy in order to be able to use the cleaner immediately in case of soiling (net contents: 90 g).

• This container is empty on delivery!



### Screw cap

Art. no. 9E161

Screw cap for retaining the transmission in the gear housing.



### Rubber adhesive

Art. no. 636W34

Beige rubber adhesive (net contents: 60 g).

646F297=D





## ▶ Auxiliary materials

---

### Plaster shirt

Art. no. 641T10=M

The plaster shirt is used when taking a plaster cast as part of the prosthetic arm fitting process. It is suitable for above-elbow residual limbs and shoulder disarticulation.



### Plaster sock

Art. no. 641T9=M

The plaster sock is used when taking a plaster cast as part of the prosthetic arm fitting process. It can be used for forearm fittings.



7in1 Controller.....	19	Chassis with threaded stud.....	123	EnergyPack.....	83
<b>A</b>		Clamp buckle.....	154, 218	ErgoArm.....	138
Adapter.....	134, 143, 166, 201, 202, 203	Clamp plate.....	139	ErgoArm Electronic plus.....	76
Adapter for Australia.....	87	Clamp sleeve, long.....	215	ErgoArm Hybrid plus.....	78
Adapter for Great Britain.....	87	Clamp sleeve, short.....	215	ErgoArm plus.....	138
Adapter with flexion.....	166	Clamp stopple set.....	143	Extension cable.....	90, 145
Alignment aid for ErgoArm.....	143	Coaxial bushing.....	67	Eyelet cable anchor, large.....	153, 215
Alignment rod.....	28	Coaxial plug.....	39, 68	Eyelet cable anchor, small.....	216
Alignment tool for adult component.....	225	Colour determination.....	171	<b>F</b>	
Alignment tool for children's component.....	29, 225	Conical drill bit (HSS).....	224	Finger and thumb cover.....	123, 161
Alignment tool for DynamicArm.....	73, 143	Connecting bracket.....	150, 212	Finger cover.....	26, 130
Allen wrench.....	29, 224	Connection cable.....	70, 88, 89	Finger filler.....	26
All-purpose hook.....	133	Connection cable with on/off switch.....	89	Fingertip blank set.....	97
All-purpose ring.....	133	Connection disc with groove.....	197	Fingertip pair.....	97, 98
Analogue adapter.....	71	Connection piece for cable-activated hook.....	131	Fingertip set.....	97
Attachment plate with short stud.....	137	Connection piece for hook.....	131	Flange button head socket screw.....	124, 162
Attachment plate with stud.....	137	Connection piece screw.....	132	Flat nose pliers.....	226
Axilla pad set.....	151, 212	Control element.....	91	Flexion cable retainer.....	197
Axillary protector for body harnesses.....	151, 212	Countersunk head screw.....	142, 153, 218	Foam modular kit.....	196
AxonArm Ergo.....	108	Coupler.....	149, 211	Forearm.....	139
AxonCharge Integral.....	110	Coupling piece.....	39, 68, 216	Friction ring.....	202
AxonEnergy Integral.....	109	Crimping tool.....	155, 220	Friction ring with inner gear teeth.....	99
AxonHook.....	103	Cyamet quick-drying adhesive.....	233	<b>G</b>	
AxonMaster.....	112	Cylindrical lamination ring.....	135	Gaiter for AxonHook.....	107
AxonRotation.....	107	<b>D</b>		<b>H</b>	
AxonRotation Adapter.....	107	Deburring knife.....	230	Harness pull switch.....	91
AxonSkin Natural.....	104	Derma Clean.....	148, 208	Harness strap.....	152, 214
AxonSkin Silicone.....	105	Derma Prevent.....	208	Hexagon nut.....	58
AxonSkin Visual/AxonSkin Black.....	105	Derma Protection ArmComfort.....	27, 59	Hole covering.....	140
AxonSoft.....	113	Derma Repair.....	208	Hollow rivet.....	155, 219
Ball cap.....	140	Digital Twin system electric hand.....	54, 55, 56	<b>I</b>	
<b>B</b>		DMC plus System Electric Hand.....	51, 52	IntoLiner Acclimate.....	146, 206
Ball ratchet wrist joint.....	136	DMC VariPlus System Electric Greifer.....	65	Isopropyl alcohol.....	232
Ball ratchet wrist joint, short.....	136	Donning sphere.....	114	<b>J</b>	
Ball-shaft adapter.....	150, 211	Donning spray.....	14, 64, 106, 148, 207	Joint ball.....	201
Battery connection cable.....	88	Donning tool.....	114	Joint clamp.....	202
Battery cover.....	98	Double spring.....	130	Joint fork.....	39
Battery receptacle.....	84, 85	"D" ring.....	153, 218	Joint piece with cable lock.....	205
Battery receptacle set.....	84, 85	Dummy set.....	148, 209	Joint piece without lock.....	205
bebionic hand.....	34	DynamicArm.....	71	<b>K</b>	
bebionic hand EQD (Quick Disconnect).....	35	DynamicArm Plus.....	72	Knurled plate.....	166
bebionic hand flex wrist.....	36	<b>E</b>		<b>L</b>	
bebionic hand short wrist (SW).....	35	EasyFit Arm donning sheath.....	27, 59	Lamination disc, serrated.....	154, 219
bebionic Skin Silicone.....	37	Eccentric.....	142	Lamination dummy.....	173
bebionic Skin Silicone Black.....	37	Elastic double strap.....	217	Lamination dummy set.....	109
Below-elbow harness.....	149, 210	Elastic harness strap.....	152, 213	Lamination dummy set for AxonMaster.....	112
Belt flap.....	205	Elbow components for children.....	21	Lamination plate.....	68
BionicLink.....	20, 95, 113	Elbow component with cable lock.....	144	Lamination protection cover.....	141
Bluetooth long dongle.....	39	Elbow component with passive lock.....	145	Lamination ring.....	22, 39, 67, 68, 107, 123, 134, 140, 144, 160, 199, 200
Bowden cable.....	149, 211	Elbow joint.....	139	Lamination ring, complete.....	15
Bracket cover.....	141	Elbow joint bars.....	204	Lamination ring for children's forearm.....	22
<b>C</b>		Elbow joint bar with cable lock.....	204	Lamination ring for Physolino baby hand.....	173
Cable-activated hook for adolescents.....	128	Elbow joint bar without cable lock.....	204	Lamination ring set.....	16, 22
Cable-activated hook for adults.....	130	ElbowSoft.....	95	Light metal piping.....	200, 203
Cable clamp.....	214	Electric Hand 2000.....	11	Li-ion charger.....	83
Cable connector.....	67	Electric rotator.....	69	Locking lever.....	86, 86
Cable pull switch.....	92	Electrode.....	24, 80, 111	Lock ring.....	58, 122
Cable seal.....	58	Electrode accessories.....	25, 81	Lock ring, wide.....	161
Cable strap buckle.....	217	Electrode accessories set.....	25, 81	Lock set.....	147, 207
Cap screw.....	201	Electrode cable with straight plug and plug connector.....	26, 82, 112		
Car charging cable, 12 volt.....	87	Electrode dome.....	41		
Chassis.....	67, 124, 160, 162	Electrode mounting bracket set.....	25, 81		
		Endoskeletal adapter.....	70		

Lock with release pin ..... 148, 209  
 Loctite 241 ..... 233  
 Loctite 243 ..... 233  
 Loctite 601 ..... 233  
 Loop ..... 154, 219

**M**

Magnetic centring aid ..... 93  
 Michelangelo hand ..... 102  
 Michelangelo hand dummy ..... 106  
 Michelangelo hand transcarpal ..... 103  
 Michelangelo socket attachment block ..... 106  
 Modular adapter for ArmLiners ..... 167  
 Modular elbow joint ..... 200  
 Mounting adapter ..... 28  
 Mounting adapter for Michelangelo ..... 114, 229  
 Mounting aid ..... 229  
 Mounting plate ..... 114, 228  
 Mounting set ..... 106, 114, 228, 229  
 Mounting wrench ..... 224  
 MovoHook 2Grip ..... 129  
 MovolinoArm Friction ..... 21  
 MovoShoulder Swing ..... 79, 198  
 MovoWrist Flex ..... 134  
 MyoBoy ..... 94  
 MyoBoy communication cable ..... 96  
 MyoBoy light set ..... 94  
 MyoCharge Integral ..... 18, 38, 83  
 MyoEnergy Integral ..... 17, 38, 82  
 MyoHand VariPlus Speed ..... 42, 43, 44  
 MyolinoLink ..... 19  
 MyolinoSkin Natural ..... 12  
 MyolinoSoft ..... 20  
 MyolinoWrist 2000 ..... 15  
 Myo Plus TR ..... 41  
 MyoRotronic ..... 69  
 MyoSelect ..... 95  
 MyoSkin Natural ..... 60, 61  
 MyoWrist 2Act ..... 66  
 MyoWrist Transcarpal ..... 66

**N**

Notched plate with inner gear teeth ..... 98

**O**

O-ring ..... 15, 142  
 O-ring set ..... 199  
 Ottobock ball shoulder joint ..... 198  
 Ottobock wrist joint ..... 23, 135  
 Oval countersunk head screw, slotted ..... 137  
 Oval head screw (sheet metal screw) ..... 135

**P**

Padded band ..... 98  
 PAULA ..... 94  
 Perlon cable ..... 23, 144, 152, 214  
 Physolino baby hand ..... 172  
 Pin ..... 147, 209  
 Pinch gauge ..... 59, 230  
 Plaster shirt ..... 235  
 Plaster sock ..... 235  
 Pliers ..... 227  
 Plug ..... 86  
 Precision screwdriver set ..... 227  
 Pressure piece ..... 142  
 Pressure switch ..... 92  
 Procomfort Gel ..... 231  
 Prosthetic glove for adolescents ..... 125, 163

Prosthetic glove for adolescents and men ..... 62  
 Prosthetic glove for children ..... 12, 13, 125, 163  
 Prosthetic glove for children and adolescents ..... 63  
 Prosthetic glove for men ..... 126, 164  
 Prosthetic glove for women ..... 62, 127, 165  
 Prosthetic gloves and inner hands for children ..... 169  
 Prosthetic gloves and inner hands for men ..... 170  
 Prosthetic gloves and inner hands for women ..... 169  
 Pull cable ..... 144, 205  
 Pump sprayer ..... 14, 64, 106, 234  
 PVC connection tube ..... 28, 93

**Q**

Quick-disconnect wrist unit with standard connector ..... 137

**R**

Remote electrode ..... 41  
 Replacement blade ..... 230  
 Retainer ring ..... 122, 161  
 Ring ..... 150, 211  
 Rocker switch ..... 92  
 Rubber adhesive ..... 234  
 Rubber band ..... 130  
 Rubber friction ring ..... 136  
 Rubber gripping pad set ..... 97

**S**

Screw cap ..... 234  
 Screw coupling ..... 155, 220  
 Screwdriver ..... 228  
 SensorHand Speed ..... 48, 49  
 Set screw ..... 124, 160, 201  
 Setting nut ..... 153, 214  
 Shoulder bracket set ..... 199  
 Shoulder disarticulation modular kit ..... 196  
 Shoulder joint ..... 79, 198  
 Side-cutting pliers ..... 226  
 Silicone grease 400, medium ..... 231  
 Skeo Up ..... 147, 207  
 Sleeve protection pad ..... 220  
 Socket attachment piece ..... 225  
 Socket screw with Allen head ..... 152, 213  
 Soldering jig ..... 229  
 Spacer sleeve ..... 151, 213  
 Spacer washer ..... 132  
 Special cleaner ..... 14, 64, 107, 234  
 Special key ..... 22  
 Special lubricant ..... 231  
 Special thread ..... 58  
 Spiral nut ..... 215  
 Spring ..... 131, 217  
 Spring set ..... 131  
 Spring telescope ..... 141  
 Stainless steel buckle ..... 150, 212  
 Standard connector ..... 136  
 Steel cable ..... 218  
 Strap buckle ..... 151, 213  
 Suction socket electrode ..... 24, 80, 111  
 Suspension rosette ..... 122, 132  
 Switch block ..... 88  
 Switch cable ..... 141  
 System hand, passive ..... 119, 159  
 System inner hand ..... 57, 122, 161

**T**

Test adapter ..... 96  
 Threaded sleeve ..... 216  
 Threaded sleeve, long ..... 216  
 Threaded support fastener ..... 154, 219  
 Thread segment ..... 140  
 Thrust washer ..... 99  
 Transcarpal Hand DMC plus ..... 53  
 Transhumeral modular kit ..... 196  
 Transhumeral soft harness ..... 210  
 Triple-control above-elbow harness ..... 149, 210  
 Truss head screw ..... 200  
 Tube dummies ..... 28, 93  
 Tube valve for elevated vacuum socket ..... 93  
 Tweezers ..... 59, 227

**U**

UHU-plus endfest 300 ..... 232  
 Universal pliers, small ..... 226  
 Universal power supply ..... 87

**V**

Vacuum forming tool ..... 224  
 Voluntary closing system hand ..... 121  
 Voluntary opening system hand ..... 120

**W**

Washer ..... 99  
 Wood hand adapter ..... 23, 173  
 Work mat ..... 226  
 Wrist joint lamination ring ..... 23

# ▶ Article number index

<b>B</b>		9E347	26	10Y1	130
BB33061	39	9E388	58	10Y12	131
<b>O</b>		9E397	67	10Y13	130
OC1560	27, 59	9E420	19	10Y19=2	155, 220
<b>4</b>		9E94	123, 160	10Y2	130
4X74	87	9S*	123	10Y25	215
<b>8</b>		9S110	68	10Y26	215
8E33=9-1	65	9S138	97	10Y3	214
8E34=9-1	65	9S145	97	10Y31	150, 211
8E38=6	51	9S148-1	98	10Y32	149, 211
8E38=7	54	9S149	97		
8E38=8	48	9S15=42	122, 161	<b>11</b>	
8E38=9	42	9S187	58, 122, 161	11D1	134
8E39=6	52	9S234=PAA	97	11D12=34	23
8E39=7	55	9S258	68	11D122	107
8E39=8	49	9S266	67	11D20	135
8E39=9	43	9S278=PAA	98	11D21	16
8E41=7	56	9S296	39	11D27	136
8E41=9	44	9S312	98	11D31	173
8E44=6	53	9S501	107	11D61	16
8E500	102	9S503	107	11S12	225
8E51	11	9S6	123, 161	11S27	99
8E550	103	9S65	162	11S30-1	99
8E600	103	9S67	162	11S33	137
8E70	35	9S96/9S184	124, 160	11S6-1	98
8E71	35	9X14	91	11S7	99
8E72	36	9X18	92		
8K18/8K19	119, 159	9X24	70	<b>12</b>	
8K22	120	9X25	92	12A13	139
8K23	120	9X37	92	12K100N	71
8K26	121	9X50/9X52	91	12K110N	72
8K27	121	9X51/9X53	91	12K12	21
8K5	172			12K19=40	21
8R1	70	<b>10</b>		12K20	145
8S11	62	10A101	131	12K27	144
8S11=210X78	126	10A12	130	12K41	138
8S11N	60	10A3	133	12K42	138
8S12	62	10A30	134	12K44	78
8S12N	61	10A37	128	12K48	139
8S13	63	10A4	133	12K49	139
8S13N	61	10A40	23, 173	12K5	145
8S20	12, 13	10A43	137	12K50	76
8S20N	12	10A56	137	12K501	108
8S4=190X76	125, 163	10A71	129	12R6	196
8S4=210X78	164	10A81	129	12R7	196
8S4=220X80	126, 164	10R1	166	12S4	79, 198
8S5=195X78	127, 165	10R2	166	12S6	79, 198
8S500	105	10R2=M12X1.5	202	12S7	198
8S501/8S502	104	10R3	166	12V10	93
8S511	105	10R4	166		
8S6=170X65	125, 163	10R5	201	<b>13</b>	
8S710*	37	10S1	39, 67	13D1	199
8S711*	37	10S16	15	13D2	199
8X14	122, 161	10S17	69	13E100	71
8X18	57	10S18=40	22	13E129=G*	26, 82, 112
8X24	57	10S4	39, 68	13E135	25, 81
8Y1	59	10S500	107	13E153	25, 81
<b>9</b>		10V15	136	13E188	88
9E161	234	10V18	135	13E190	88
9E167	67	10V18=34	23	13E190=150	88
9E169	39, 68	10V30	136	13E200	24, 80, 111
9E185	90	10V36	135	13E201	25, 81
9E185=50-1	145	10V36=34	23	13E202	24, 80, 111
9E342	26	10V38	66	13E205	69
		10V39	134	13E206	25, 81
		10V40	66	13E400=*	41
		10V51	15	13E401=*	41
		10V8	136	13E50	89

# ▶ Article number index

13E500	112	21A47	210	560X500	113
13E520	41	21A5	153, 215	<b>623</b>	
13E97	89	21A6	215	623G23	152, 213
13E99=1200	89	21A7	216	623G4	217
13G21	22	21A8	122, 132	623H23	152, 214
13G68	139	21A9	132	<b>624</b>	
13G8=54	22	21Y194	150, 211	624Z12	58
13G8=67	144, 200	21Y195=25	150, 212	<b>627</b>	
13R1	200	21Y197=1	150, 212	627F13=25X2	15
13R3	200	21Y199	151, 213	627F13=60X2.5	142
13R4	203	21Y203	151, 213	<b>633</b>	
13R6	203	21Y37	217	633F11	231
13R9	197	21Y79	205	633F14=*	231
13R11	167	<b>29</b>		633S2	231
13X3	202	29C5	153	<b>634</b>	
13X4	202	29C5=MX4X9	214	634A58	232
13X5	201	<b>60</b>		636K11	233
13Y1	197	60X5	20, 95, 113	636K13	233
13Z16=43	199	60X6	19	636K14	233
13Z161/13Z162/13Z163	41	<b>99</b>		636W23	232
13Z47	140	99B13	28, 93	636W34	234
13Z48	140	99B83	28, 93	636W60	233
13Z50	140	<b>453</b>		<b>640</b>	
13Z51	140	453A1	27, 59	640F12	14, 64, 107, 234
13Z52	141	453H10	148, 208	640F13	14, 64, 106, 234
13Z53	141	453H12	208	640F18	14, 64, 106, 148, 207
13Z55	141	453H14	208	640Z6	226
13Z56	141	<b>501</b>		<b>641</b>	
13Z57	142	501S101=M4X12	142	641T9=M	235
13Z58	142	501S27=M3X8	137	641T10=M	235
13Z68	143	501S28=M3.5X5	153, 218	<b>646</b>	
<b>14</b>		501S35=M4X6	200	646C42	94, 95
14A1	147, 207	501S40	135	<b>651</b>	
14A107	147, 209	501S84=M4X20	142	651D4=2	218
14A110	148, 209	501T52=M3X6	124, 162	<b>706</b>	
14A111	148, 209	501T52=M3X8	124, 162	706F1=125	226
14Y3	146, 206	501Z2=M4X18	201	706R4	226
14Y5	147, 207	<b>502</b>		706Z10	227
<b>15</b>		502S97=M5	58	706Z2	226
15K10	196	<b>503</b>		709S10=2	29, 224
15Y1	220	503F3	152, 213	709S42	29
<b>16</b>		<b>504</b>		709Z9	22
16X12	204	504H3=11-100	155, 219	<b>710</b>	
16X13	204	<b>506</b>		710H3	227
16X14	204	506G1=M6X10	201	710H4	228
16Y26	144, 205	506G4	124, 160	<b>711</b>	
16Y27	205	<b>507</b>		711M1	114, 228
16Y31	205	507S15	154, 219	711M114	114
<b>21</b>		<b>514</b>		711M116	114
21A10	132	514K3=27	154, 218	711M12	229
21A11	216	514Z3=25	154, 218	711M16	229
21A12	216	<b>516</b>		711M18	224
21A13	131	516S3	154, 219	711M2	114, 228
21A16	153, 218	<b>560</b>		711M20	28
21A18	23, 144, 152, 214	560X3	20	711M3	228
21A207	143			711M50-1	28
21A24	216				
21A25	217				
21A29	151, 212				
21A35	149, 210				
21A36	149, 210				
21A37=1	149, 211				
21A38	151, 212				
21A44	131				

## Article number index

---

711M53	224
711M64	114, 229
711M7	229
711M77	93

### 718

718H5	230
718Y1	230

### 726

726W9	224
-------	-----

### 736

736Y6	155, 220
-------	----------

### 743

743A18	225
743A19	29, 225
743A23	143
743A27	73, 143
743F1	59, 230
743Y42=24	173

### 757

757B2*	83
757B35=*	17, 38, 82
757B501	109
757L16-4	87
757L20	83
757L35	18, 38, 83
757L500	110
757M11=X-Change	94
757M11=2-K50	94
757P23	96
757P39	96
757P41	88
757S1=AUS-4	87
757S1=GB-4	87
757T13	95
757Z184=1	84
757Z184=2	84
757Z185=1	84
757Z185=2	84
757Z186	86
757Z190=1	85
757Z190=2	85
757Z191=1	85
757Z191=2	85
757Z195	86
757Z202	86
757Z501	106
757Z503	112
757Z504	106
757Z505	106
757Z508	109

### 799

799P1	227
799P2	227



## Notes

---

---

---

---

---

---

---

---

---

---

---

---

---

---

---

---

---

---

---

---

---

---

---

# ▶ Notes

---

A series of horizontal dotted lines for writing notes.

# ▶ Notes

---

A series of horizontal dotted lines for writing notes.

Ottobock SE & Co. KGaA  
Max-Näder-Straße 15 · D-37115 Duderstadt, Germany  
T +49 5527 848-0 · F +49 5527 848-1414  
info@ottobock.com · www.ottobock.com