



ENERGIZE YOUR LIFESTYLE

**LX02 (EEC L1e-B)**



**COC**





ENERGIZE YOUR LIFESTYLE

## ESPECIFICACIONES

INFORMACIÓN	MODELO LX02
DIMENSIONES (L*A*A)	1740 X 680 X 1090 mm
DISTANCIA ENTRE EJE RUEDAS	1240 mm
MOTOR	2050W BOSCH
BATERÍA DE LITIO	48V/26AH SAMSUNG
TAMAÑO RUEDA	3.0 - 10" TUBULAR
FRENOS	FRENO DE DISCO AMBAS RUEDAS
VELOCIDAD MÁXIMA	55 KM/H
AUTONOMÍA	50 - 70 KM
PESO MÁXIMO	150 KG
INCLINACIÓN MÁXIMA	13° (25%)

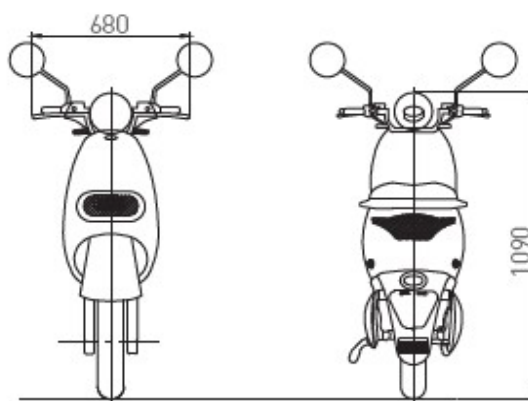
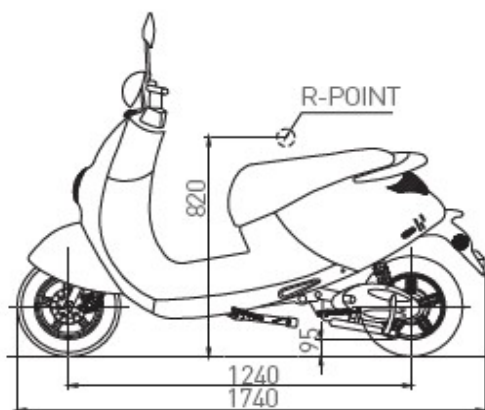

Units: mm

\*Autonomía óptima: Usuario 70 kg. / 20° C / Velocidad Constante 40 km/h / Superficie plana  
**LX02 (EEC L1e-B)**