

COMMERCIAL & INDUSTRIAL



HIGH-VOLUME HOT WATER SOLUTIONS



STEADY, HOT & STRONG

INSTALL A RHEEM®



TRUST IN RHEEM, THE PREMIER COMMERCIAL WATER HEATER COMPANY IN NEW ZEALAND

Our reputation is built on reliability, support and integrity. We're providing a range of water heating solutions.

It's who we are!

Rheem is up to the job

Today, more than ever, Rheem is the right choice to make.

We're the leaders in designing and manufacturing water heaters specifically for commercial applications.

Rheem has been manufacturing water heaters in Australian and New Zealand plants since 1939 and 1973 respectively, and with Research and Development facilities throughout Australia, New Zealand and across the globe our expertise is second to none. We are also committed to solar technology as the largest solar water heater manufacturer in Australasia.

Our water heaters are robust and designed for the demands of business and industry.

We have the right Rheem for you

Rheem has the most extensive range of energy efficient hot water systems in Australasia. Whether you need Solar, Gas or Electric Storage, Gas Continuous Flow, Heat Pump, Boiling Water or Warm Water, Rheem has a truly commercial range and the know-how to put it all together.

Our highly trained, professional team is committed to delivering high quality product solutions.

CONTENTS

CONTINUOUS FLOW HOT WATER	04
HEAVY DUTY GAS STORAGE	20
RAYPAK® HEATING & HOT WATER	27
HEAVY DUTY ELECTRIC	34
COMMERCIAL ELECTRIC HEATING UNIT	38
COMMERCIAL HEAT PUMP	40
HEAT EXCHANGER TECHNOLOGY	47
GUARDIAN WARM WATER	52
STORAGE TANKS	55
COMMERCIAL SOLAR SOLUTIONS	60
BOILING AND CHILLED WATER	68
PUMP ACCESSORIES	81
EQUA-FLOW® MANIFOLDING	83
WARRANTIES	85
SIZING GUIDE	86

CONTINUOUS FLOW HOT WATER

6-star energy efficiency,
mains pressure delivery,
space and energy
saving options.

Factory-tested,
pre-assembled,
and delivered as
a complete package.

We have two large Rheem Continuous Flow Tankpak systems providing mains pressure water throughout our building. Since building handover, these systems have provided excellent hot water delivery to all our tenants with zero complaints - I'm very happy with the Rheem systems.

Leon Liu, Building Manager -
Vanguard Apartments/Sebel Malvern

CASE STUDY

ICC

SYDNEY, NSW

Challenge

The \$1.5 billion ICC Sydney at Sydney's Darling Harbour is Asia-Pacific's premier integrated convention, exhibition and entertainment precinct. This world-class facility required a reliable hot water solution, capable of hosting three separate events concurrently, including a 8000-capacity red carpet theatre.

Hot Water Solution

Rheem supplied 8 commercial hot water plants, that were used to service the theatre, convention and exhibition centres, including 7 x Rheem Tankpaks, consisting of high-efficiency commercial continuous flow gas water heaters manifolded together with commercial buffer storage. This was combined with a Rheem Raypak gas heater system with commercial buffer storage tanks, along with a commercial solar pre-heat system (used to offset gas consumption).



CONTINUOUS FLOW HOT WATER

FOR CONTINUOUS HOT WATER FLOW
IN HIGH-DEMAND ENVIRONMENTS



NATURAL
GAS & ULPG

6 ★ STAR
ENERGY

FRST
PROTECTION

FAULT
PROTECTION

The continuous flow water heater with 6-star energy efficiency

High energy efficiency

6-star energy rating and 84% thermal efficiency.

Constant temperature.

Compatible with other systems

Compatible with solar, heat pump and waste heat systems. EZ Link[®] two units together for 54L per minute.

Fault protection

Unique Flame Safe[®] technology detects heat exchanger faults and shuts the system down.



External Model

Internal Model

More key features

- Digital temperature display (Tankpak, Multipak, Commpak and Commpak Plus)
- Internal and external models available
- Natural gas and ULPG models
- Frost protection
- Suitable for sanitising applications when set at 82°C

Commercial Continuous Flow Water Heater warranty: 1 year on heat exchanger, 1 year on parts & labour

TECHNICAL DATA

RHEEM COMMERCIAL CONTINUOUS FLOW		EXTERNAL 27L MODEL	INTERNAL 27L MODEL
Model		872627	862627
Delivery Temperature	°C	up to 82	up to 82
Input	MJ/h	205	205
Output	kW	47.5	47.5
Efficiency	%	84	84
Gas Energy Rating	Stars	6	6
Flow Rate @ 25°C Rise	L/min	27	27
Minimum Flow Rate	L/min	2	2
Dimensions			
Height	mm	600	650
Width	mm	350	350
Depth	mm	226	250
Frost Protection		yes	yes
Approximate Weight	kg	23	23
Inlet/Outlet Connections	BSPM	R ³ / ₄ /20	R ³ / ₄ /20
Gas Connection	BSPM	R ³ / ₄ /20	R ³ / ₄ /20
Water Supply Pressure			
Maximum	kPa	1000	1000
Minimum	kPa	140	140
Gas Supply Pressure Range			
Natural Gas	kPa	1.13 – 3.5	1.13 – 3.5
UPLG	kPa	2.75 – 3.5	2.75 – 3.5
Temperature Settings	°C	38, 40, 42, 43, 45, 50, 55, 60, 65, 70, 75, 82	38, 40, 42, 43, 45, 50, 55, 60, 65, 70, 75, 82
Factory Set Temperature	°C	60	60
Co-Axial Flue Specification			
Inner – Material/Diameter	mm	NA	316L or 444/78
Outer – Material/Diameter	mm	NA	Aluminised Steel/127
Maximum Flue Run		NA	13.5m and no bends*
Accessories			
Pipe Cover		320116	NA
Recess Box		320316	NA
Security Bracket		320591	320591
Gas Booster Mounting Kit (suit TP01)		299237**	299237**
EZ Link® Kit Max 60°C (Deluxe Kitchen Controller not included)		299291	299291
Deluxe Temperature Controllers (Max 60°C)			
Kitchen		A299861	A299861
Bathroom 1		A299862	A299862
Bathroom 2		A299863	A299863

* Reduce the maximum length by 1.5m for every 90° bend and by 0.75m for every 45° bend. The flue system is suitable for vertical and horizontal termination when used with the appropriate terminal.

**Kit needs to be ordered separately.

RHEEM TANKPAK

Tankpak 1 (Concept Option)

FOR CONTINUOUS HOT WATER FLOW
IN HIGH DEMAND ENVIRONMENTS



NATURAL
GAS & ULPG

6 ★ STAR
ENERGY

FRST
PROTECTION



The Rheem Tankpak combines the benefits of mains pressure and continuous flow water heating.



Manifolded banks of Continuous Flow Water Heaters (CFWH) meet the requirements of peak demand periods, whilst the storage tank provides buffer for peak simultaneous demands.

How it works

The thermostat senses the water in the storage tank and activates the primary pump, which in turn activates the continuous flow water heaters. Water is drawn from the bottom of the tank and is returned to the hot water outlet at the top of the tank. When the thermostat senses water in the tank at set point, the pump and water heaters are turned off.

Top Down Heating

Rheem Tankpak utilises the top down heating principle. This allows the coldest water to be supplied to the continuous flow water heaters for the longest period of time to maximise the recovery rate whilst providing hot water immediately for use.

Other systems utilise a traditional return fitting on the storage tank, which provides warmer water to the continuous flow water heater. This causes water heaters to modulate the gas input and reduce the effective recovery rate.

TankPak 1 (Concept Option) warranty:
5 years on VE cylinder, 8 years on SS cylinder,
1 year on heat exchanger, 1 year on parts & labour

Range

Rheem Tankpak (concept option) is available from 1 to 10 Continuous Flow Water Heaters (CFWH) with 1, 2 or 3 storage tanks, depending on system size. Larger systems are available on application. Indoor or outdoor CFWH are assembled in banks from 2 to 6 units by the installer, available in natural gas or ULPG. Please note, for systems greater than 6 CFWH the manifolds must be interconnected in equaflow on site by the installer. Ask Rheem how.

Features include:

- 84% thermal efficiency heat source
- Vitreous enamel storage tank up to 82°C operation
- Large flow 50mm storage tank fittings
- High storage tank delivery rating due to innovative top down heating
- Digital temperature display
- Indoor and outdoor models available
- Pre-designed CFWH banks
- All components supplied loose for easy on-site installation

Benefits include:

- Mains pressure performance
- Reduced footprint
- High recovery
- Redundancy backup

TYPICAL INSTALLATION

Typical Installation with TP03 shown

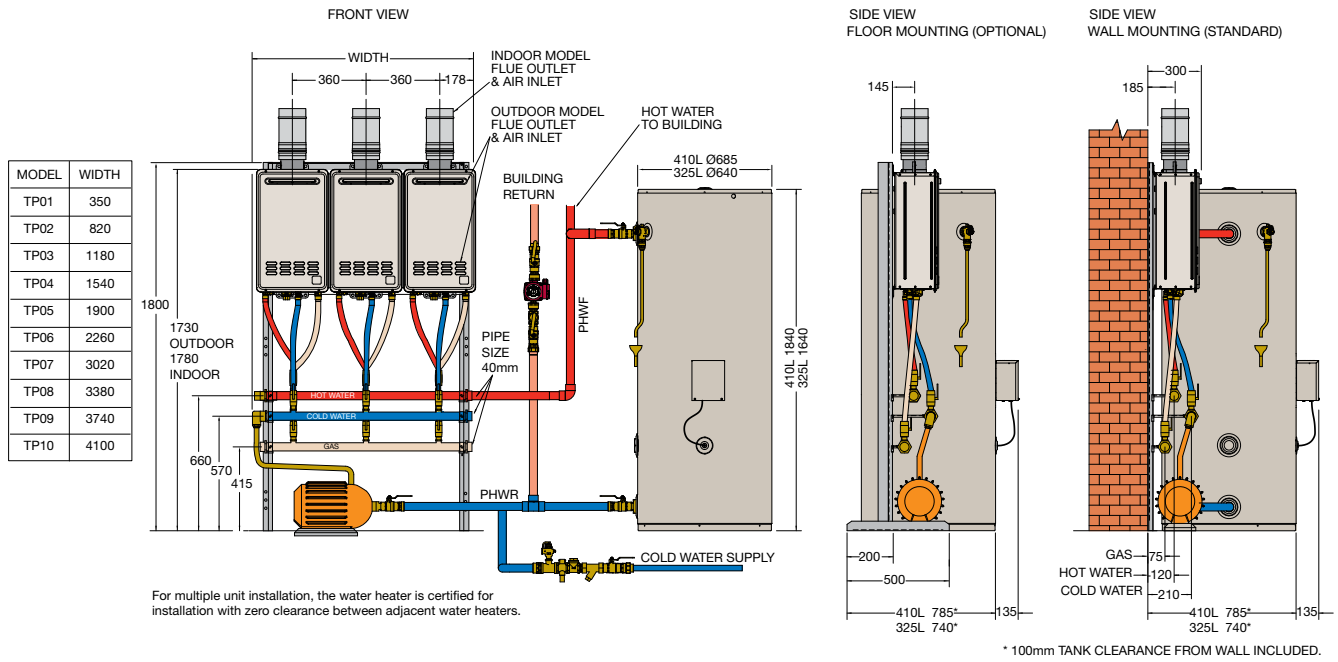

TANKPAK TECHNICAL DATA

Model	No. CFWH	Thermal Input (MJ/h)	Recovery @ 50°C Rise (L/hr)	Storage Tanks	1st Hour Delivery (L)	Primary Flow and Return Pipe Size (mm)*	Gas Pipe Size		Pump Model	Pump Part Number	Weight [^] (kg)
							NG (mm)*	ULPG (mm)			
TPI01 TPE01	1	205	803	A610340	1063	25	20	20	UPS32-80N	56860243	122
TPI02 TPE02	2	410	1606	A610340	1866	40	40	40	CM 3-2	366084	203
TPI03 TPE03	3	615	2409	A610340	2669	40	40	40	CM 3-2	366084	228
TPI04 TPE04	4	820	3213	A610340	3473	40	40	40	CM 3-2	366084	293
TPI05 TPE05	5	1025	4016	A610430	4344	40	40	40	CM 5-2	366089	340
TPI06 TPE06	6	1230	4819	A610430	5147	40	40	40	CM 5-2	366089	365
TPI07 TPE07	7	1435	5622	2x A610340	6142	50	50	40	CM 5-2	366089	510
TPI08 TPE08	8	1640	6425	2x A610340	6945	50	65	40	CM10-1	366094	580
TPI09 TPE09	9	1845	7228	2x A610430	7748	50	65	40	CM10-1	366094	647
TPI10 TPE10	10	2050	8032	2x A610430	8688	50	65	40	CM10-1	366094	672

* For systems using more than 6 CFWH, each manifold assembly must be plumbed in parallel.

[^] Weight includes CFWH unit, storage tank empty, pump and assumed likely weight of frame and manifolds.

NB: TPI = Internal, TPE = External

TANKPAK SERIES 2[®]

Prebuilt on a frame

FOR COMMERCIAL APPLICATIONS OF ALL SIZES



HIGH WIND RATING

FAST INSTALLATION

FAST COMMISSIONING

MEETS PEAK DEMAND

Top down heating for faster hot water delivery and better redundancy.



High wind certified

Engineer certified for high wind rating (up to 45m depending on the location). Lifting lugs are also engineer certified.

Fast commissioning

TankPak's top down heating design delivers hot water to the building instantly.

Fast installation

Rheem factory-tests each order before supplying the entire CFWH system, including GPOs, pump and controller, so there are no delays on site.

Meets peak demand

TankPak's top-down heating design and tank storage with large flow 50mm fittings, meet peak simultaneous demands.

Built-in redundancy.

Innovative plumbing design provides a direct line from the water heater to the building, which means there's no interruption to hot water supply during maintenance.

Wall Mount (W) / Floor Mount (F) / Back To Back (B)

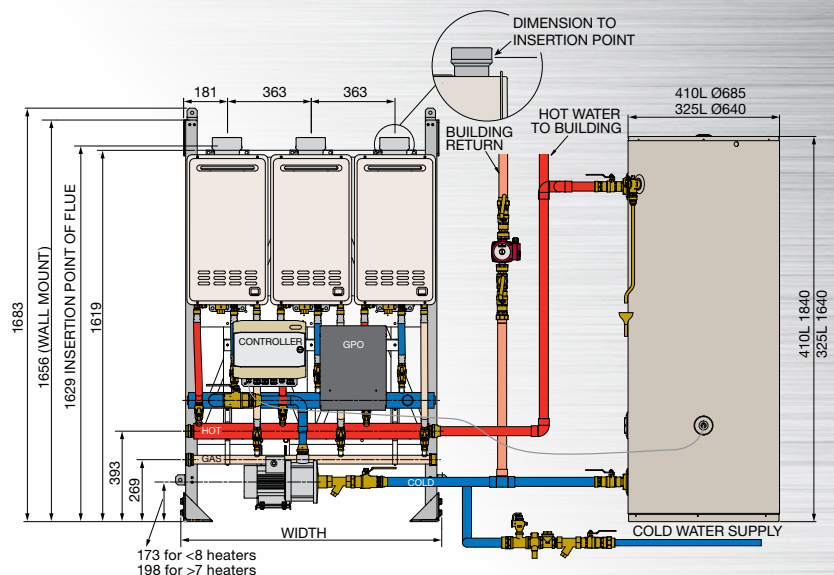

More key features

- Watermark AS-NZS 4020 certified
- Modular frame system allows easy dismantling
- Plumb to right or left-hand side
- Wall and floor-mounted in line and back-to-back options
- Variety of storage tank options suitable for sanitisation applications

TankPak Series 2[®] warranty: 5 years on VE cylinder, 8 years on SS cylinder, 1 year on heat exchanger, 1 year on parts & labour

TECHNICAL DATA

TANKPAK MODEL	INTERNAL EXTERNAL	S2TPI 02 S2TPE 02	S2TPI 03 S2TPE 03	S2TPI 04 S2TPE 04	S2TPI 05 S2TPE 05	S2TPI 06 S2TPE 06	S2TPI 07 S2TPE 07
Thermal Input	MJ/h	410	615	820	1025	1230	1435
Recovery Rate at 50°C rise	L/hr	1645	2470	3290	4115	4935	5760
Mounting options		W/F	W/F	W/F/B	W/F/B	W/F/B	W/F/B
Storage Tank Options		1 x A610340 1 x A610430	1 x A610340 1 x A610430	1 x A610340 1 x A610430	- 1 x A610430	- 1 x A610430	- 1 x A610430
1st Hour Capacity (340L)	Litres	1970	2795	3615	-	-	-
1st Hour Capacity (430L)	Litres	2055	2880	3700	4525	5345	6170
Electrical Supply (240V/50Hz)	Amps	4.0	4.8	5.5	7.0	7.8	8.6
Electrical Connection		1.8m 10A Plug and Lead					
PHWF & PHWR Pipe Size	mm	25	32	40	40	40	50
Natural Gas Pipe Size	mm	40	40	50	50	50	50
ULPG Pipe Size	mm	32	32	32	32	32	32
Width (Inline)	mm	755	1118	1481	1844	2207	2570
Width (Back to Back)				755	1118	1118	1481
Weight Empty (F/B)*	kg	239	278	314/297	375/338	413/363	458/405

* Weight includes CFWH unit, storage tank empty, pump, frame and preassembled manifolds. Tankpak models with 1 x CFWH are supplied loose with CFWH, pump & controller separately. The CFWH must be mounted on a vertical wall or use Mounting Bracket 299237.

Back To Back (B)

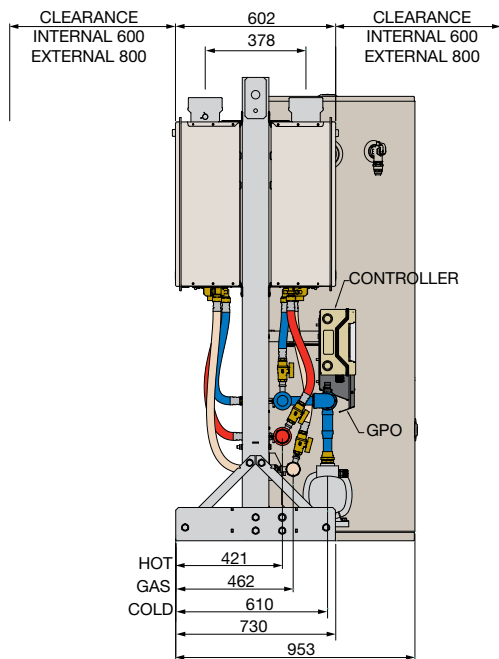

Wall Mount (W)

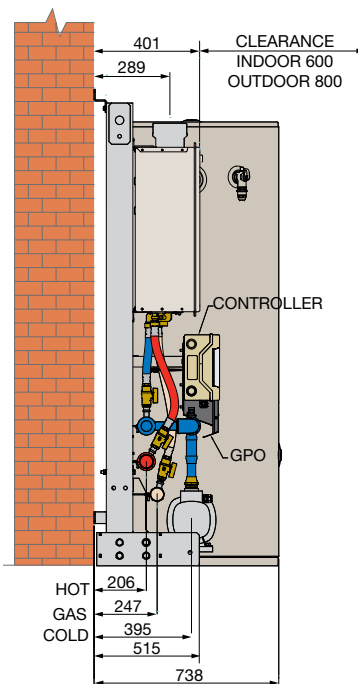

Floor Mount (F)

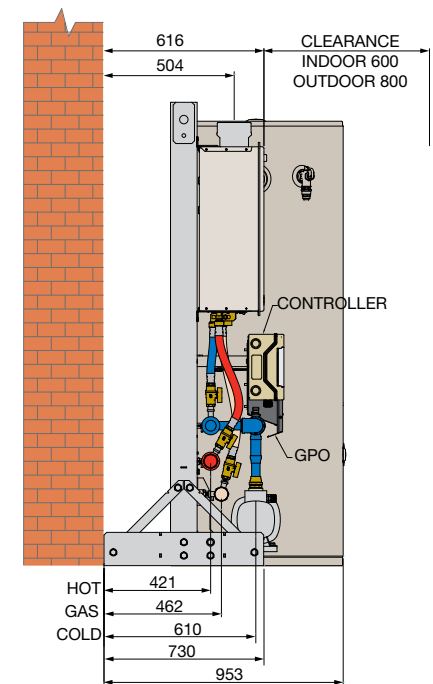

TECHNICAL DATA

TANKPAK MODEL	INTERNAL EXTERNAL	S2TPI 08 S2TPE 08	S2TPI 09 S2TPE 09	S2TPI 10 S2TPE 10	S2TPI 12 S2TPE 12	S2TPI 14 S2TPE 14	S2TPI 16 S2TPE 16	S2TPI 18 S2TPE 18
Thermal Input	MJ/h	1640	1845	2050	2460	2870	3280	3690
Recovery Rate at 50°C rise	L/hr	6580	7405	8225	9875	11520	13165	14810
Mounting options		W/F/B	W/F/B	B	B	B	B	B
Storage Tank Options		-	-	-	-	-	-	-
		2 x A610430	2 x A610430	2 x A610430	2 x A610430	3 x A610430	3 x A610430	3 x A610430
1st Hour Capacity (340L)	Litres	-	-	-	-	-	-	-
1st Hour Capacity (430L)		7400	8225	9045	10695	12750	14395	16040
Electrical Supply (240V/50Hz)	Amps	10.6	11.4	12.2	14.8	15.5	16.9	18.5
Electrical Connection		240V 50Hz Single phase hard wired connection						
PHWF & PHWR Pipe Size	mm	50	50	50	50	65	65	65
Natural Gas Pipe Size	mm	65	65	65	80	80	80	80
UPLG Gas Pipe Size		40	40	40	40	50	50	50
Width (Inline)	mm	2933	3296	-	-	-	-	-
Width (Back to Back)		1481	1844	1844	2207	2570	2933	3296
Weight Empty (F/B)*	kg	617/551	677/622	646	712	897	962	1062

How to specify/order the right model

PRODUCT CODE EXAMPLE	NO. OF UNITS	GAS TYPE	MOUNTING OPTION	NO. OF TANKS AND CAPACITY
S2TPE (external) + or S2TPI (internal)	10 +	N (Natural gas) + or P (ULPG)	B (Back to Back) + or W (Wall Mount) or F (Floor Mount)	D (Deluxe) /2 + 430

Order code result: **S2TPE10NBD/2430** For Tankpak Series 2[®] with 10 Natural Gas units mounted back to back, pre-wired (deluxe) with 2x 430L storage tanks. NB: 340 & 430L tanks can be supplemented or replaced by RT1000-5000L options - see Page 59.

TANKPAK QUICK SIZING GUIDE

Studio ^a	Apartments 1 hr peak			Hotel Rooms 1 hr peak	Amenities 30 min peak	Nursing home 2 hr peak	Tankpak Series 2 Model	Recovery @ 50°C Rise (L/hr)	Storage Tank Capacity (L)	First Hour Capacity (L)	Thermal Input (MJ/h)
	1 & 2 bedroom ^a	2 bedroom ^a	2 & 3 bedroom ^a								
49	21	16	14	24	32	30	S2TP01/1430**	825	410	1235	205
82	35	27	24	41	49	54	S2TP02/1430	1645	410	2055	410
115	50	38	34	57	65	79	S2TP03/1430	2470	410	2880	615
148	64	49	44	74	82	103	S2TP04/1430	3290	410	3700	820
181	78	60	54	90	98	128	S2TP05/1430	4115	410	4525	1025
213	92	71	64	106	115	152	S2TP06/1430	4935	410	5348	1230
246	107	82	74	123	131	176	S2TP07/1430	5760	410	6170	1435
296	128	98	89	148	164	207	S2TP08/2430	6580	820	7400	1640
329	143	109	99	164	180	231	S2TP09/2430	7405	820	8225	1845
361	157	120	109	180	197	255	S2TP10/2430	8225	820	9045	2050
427	186	142	129	213	230	304	S2TP12/2430	9875	820	10695	2460
510	221	170	154	255	279	359	S2TP14/3430	11520	1230	12750	2870
575	250	191	174	287	312	408	S2TP16/3430	13165	1230	14395	3280
641	278	213	194	320	345	457	S2TP18/3430	14810	1230	16040	3690

* Weight includes CFWH unit, storage tank empty, pump, frame and preassembled manifolds. Tankpak models with 1 x CFWH are supplied loose with CFWH, pump & controller separately. The CFWH must be mounted on a vertical wall or use Mounting Bracket 299237.

a Allowance - studio 25L, 1 bedroom 40L, 2 bedroom 75L, 3 bedroom 90L. Calculated on even ratio of apartment mix.

b Allowance - 2 people per room, 25L per person.

c Allowance - 25L per shower.

d Allowance - 37.5L per bed for showering, bed pans, cleaning, 6L per bed for meals, 24L per bed for laundry.

**Concept system only.

FOR CARAVAN PARKS, SMALL
STADIUMS AND SPORTS FACILITIES



HIGH
EFFICIENCY

FAST
INSTALLATION

MEETS
PEAK
DEMAND

The staged ignition
hot water system that
meets intermittent high
demand.

Meets high demand when needed

Staged ignition system allows large, but intermittent hot water demands, as well as small demands to be met easily, without maintaining heating during unused periods.

Fast and efficient to install

Rheem factory-tests each order before supplying the entire CFWH system, so there are no delays on site.

Tempering

In 60–82°C temperature setting, suitable for use in dead leg and recirculation systems with tempering. In 55°C mode, suitable for use without the need for external tempering devices for dead leg applications only.*

More key features

- Natural gas and ULPG models
- Left or right-hand plumbing
- Wall and floor mount options
- Optional factory-fitted secondary hot water circulator available



* 55°C limited systems are suitable for dead leg applications only. Further tempering may be required. Consult AS3500.4 for details.

MultiPak® warranty: 1 year on heat exchanger, 1 year on parts & labour

TECHNICAL DATA

MULTIPAK MODEL	INTERNAL EXTERNAL	MPI 02 MPE 02	MPI 03 MPE 03	MPI 04 MPE 04	MPI 05 MPE 05	MPI 06 MPE 06
Input	MJ/h	410	615	820	1,025	1,230
Recovery Rate at 50°C rise	L/hr	1,645	2,470	3,290	4,115	4,935
Maximum Flow Rate at 50°C rise	L/min	27	41	54	68	81
Minimum Flow Rate	L/min	2.0	2.0	2.0	2.0	2.0
Approx Weight	kg	95	120	185	210	235
Wall Mount		standard	standard	standard	standard	standard
Free Standing Frame (FSF)		optional	optional	optional	optional	optional
Electrical Supply (240V/50Hz)	Amps	1.50	2.25	3.0	3.75	4.5
Electrical Connection	1.8m 10A Plug and Lead per CFWH					
Dimensions						
Width	mm	820	1180	1540	1900	2260
Depth (Wall Mount / Free Standing Frame)	mm	360/500	360/500	360/500	360/500	360/500
Frost Protection		Yes	Yes	Yes	Yes	Yes
Accessories - Secondary circulator*	part number	299658	299658	299658	299658	299658

*Secondary hot water circulator option not available on systems set to deliver 55°C

Front view

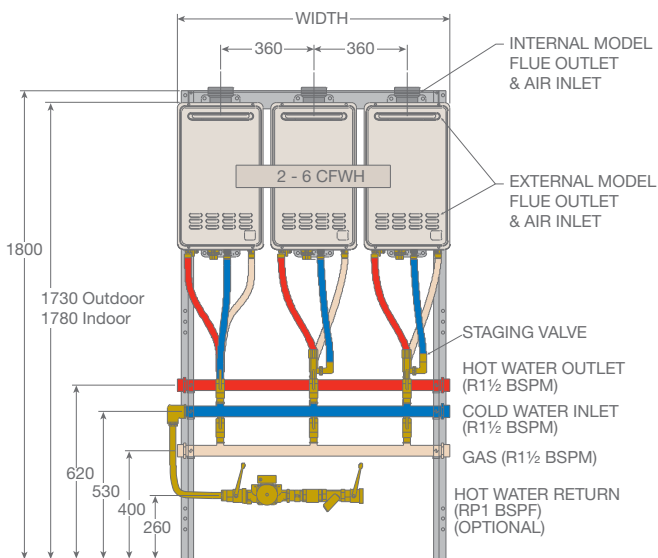

**These dimensions are applicable only for 2 and 3 Multipak systems

Side view floor mounting

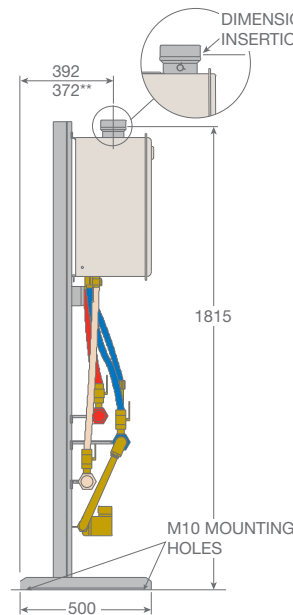

Side view wall mounting

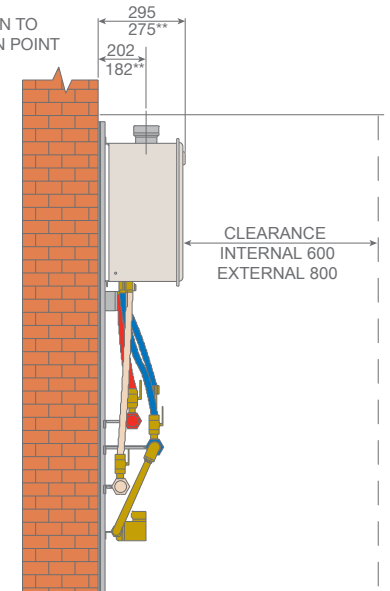

FOR SMALL TO MEDIUM
COMMERCIAL APPLICATIONS



NATURAL
GAS ONLY



SMALL

FAST
INSTALLATION

MAINS
PRESSURE



Tankless mains pressure performance.



Mains pressure hot water in a small footprint

Sophisticated electronics and pump technology equalises hot and cold water pressures, and a differential set point combined with the thermal mass in the system piping replicates storage.

Fast and efficient to install

Rheem factory-tests each order before supplying the entire CFWH system, including GPOs, pump and controller, so there are no delays on site.

BMS capable

Central control operation with fault monitoring.

More key features

- Optional Duty/Standby pumps for additional redundancy
- Install inline up to 6 on one frame
- Loss of prime protection – turns off Commpak® system if water pressure is lost

CommPak® warranty: 1 year on heat exchanger, 1 year on parts & labour

TECHNICAL DATA

COMMPAK MODEL	INTERNAL EXTERNAL	CPI 02 CPE 02	CPI 03 CPE 03	CPI 04 CPE 04	CPI 05 CPE 05	CPI 06 CPE 06
Input	MJ/h	410	615	820	1,025	1,230
Recovery Rate at 50°C rise	L/hr	1,645	2,470	3,290	4,115	4,935
Peak Flow Rate at 50°C rise	L/min	27	41	54	68	81
Approx Weight	kg	120	150	220	245	270
Free Standing Frame (FSF)		standard	standard	standard	standard	standard
Electrical Supply (240V/50Hz)	Amps*	3.62	4.62	5.62	6.62	7.92
Electrical Connection		Hard Wired	Hard Wired	Hard Wired	Hard Wired	Hard Wired
Dimensions						
Width	mm	1330	1330	1690	2050	2410
Depth (Free Standing Frame)	mm	500	500	500	500	500
Frost Protection		Yes	Yes	Yes	Yes	Yes
Accessories - Duty/Standby pump	part number	299659	299659	299659	299659	299659

* Single pump. Add 1.62 Amps for Duty/Standby pump option.

Front View

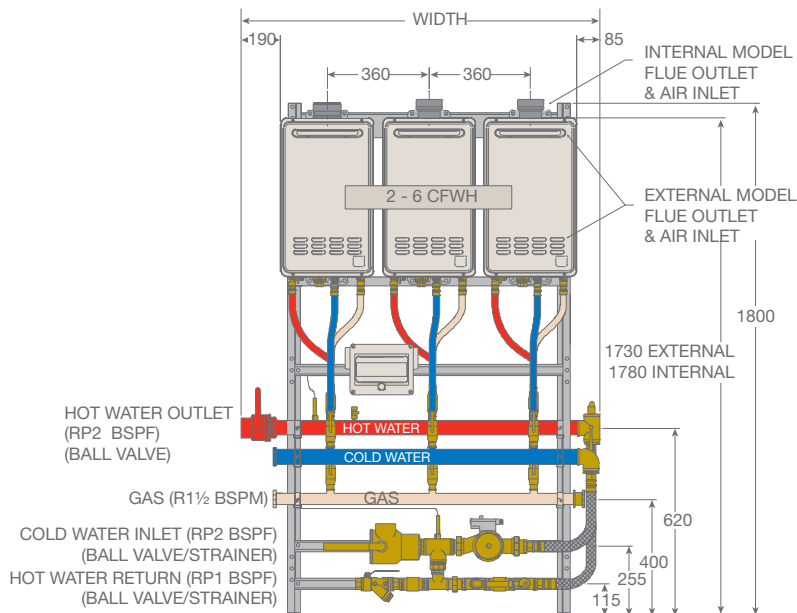

Side view floor mounting

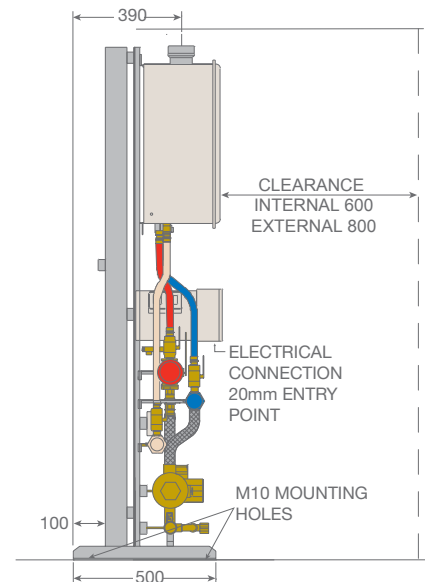

FOR LARGE COMMERCIAL APPLICATIONS



NATURAL GAS ONLY

BUILT-IN REDUNDANCY

SMALL

FAST INSTALLATION

MAINS PRESSURE



Staged tankless mains pressure and built-in redundancy, in a small footprint.

Built-in redundancy and extended life

Commpak Plus® stages half of the pak with one pump, depending on demand, extending water heater and pump life.

Mains pressure hot water in a small footprint.

Sophisticated electronics and pump technology equalises hot and cold water pressures. A differential set point combined with the thermal mass in the system piping replicates storage.

Fast and efficient to install

Rheem factory-tests each order before supplying the entire CFWH system, including GPOs, pump and controller, so there are no delays on site.

BMS capable

Central control operation with fault monitoring.

More key features:

- Loss of prime protection – turns off Commpak Plus® system if water pressure is lost.
- In-line or back to back arrangements are available to meet plant room space availability (model dependent).



Photo: Back to back 18 Unit Commpak Plus®

Inline 7 -12 Commpak Plus®

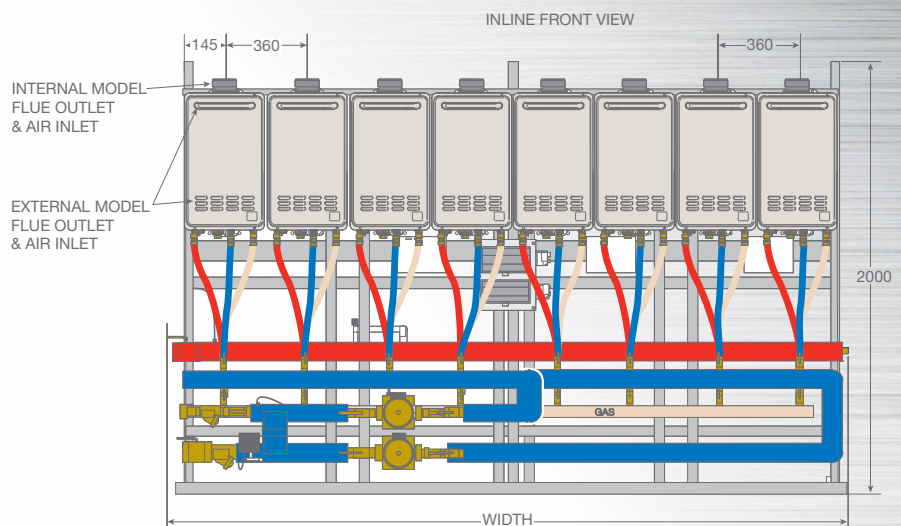

Commpak Plus® warranty: 1 year on heat exchanger, 1 year parts & labour

TECHNICAL DATA

COMMPAK PLUS MODEL	INTERNAL EXTERNAL	CPI 07 CPE 07	CPI 08 CPE 08	CPI 09 CPE 09	CPI 10 CPE 10	CPI 11 CPE 11	CPI 12 CPE 12	CPI 14 CPE 14	CPI 16 CPE 16	CPI 18 CPE 18
Input	MJ/h	1435	1640	1845	2050	2255	2460	2870	3280	3690
Recovery Rate at 50°C rise	L/hr	5761	6584	7407	8230	9053	9876	11522	13168	14814
Maximum Flow Rate at 50°C rise	L/min	96.0	109.6	123.3	137.0	150.7	164.4	191.8	219.2	246.6
Approx Weight	kg	350	380	410	440	470	500	570	640	710
Cold Water/Hot Water										
7-14: Threaded Connection	BSPF	RP2	RP2	RP2	RP2	RP2	RP2	RP2	-	-
16-36: Table E Flanged End	mm	-	-	-	-	-	-	-	65	65
Return	BSPF	RP1	RP1	RP1	RP1	RP1	RP1	RP1¼	RP1¼	RP1¼
Gas	BSPM	R2	R2	R2	R2	R2	R2	R2	R2	R2½
Electrical Supply (240V/50Hz)	Amps	10.24	11.24	12.24	13.24	14.24	15.24	17.24	-	-
Electrical Supply (415V/3 phase/50Hz)	Amps	-	-	-	-	-	-	-	11.0	11.0
Dimensions										
Width - inline	mm	2670	3030	3390	3750	4110	4470	-	-	-
Width - back to back	mm	1980	1980	2340	2340	2700	2700	3310	3670	4030
Frost Protection		Yes	Yes	Yes	Yes	Yes	Yes	Yes	Yes	Yes
Relief Valve Setting	kPa	1000	1000	1000	1000	1000	1000	1000	1000	1000
Water Supply Pressure										
Minimum/Maximum	kPa	140/800	140/800	140/800	140/800	140/800	140/800	140/800	140/800	140/800

Inline 7 -12 Commpak Plus® Side view

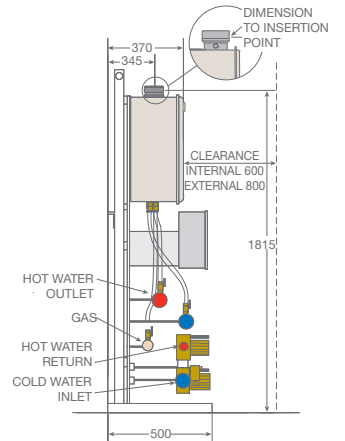

COMMPAK PLUS MODEL	INTERNAL EXTERNAL	CPI 20 CPE 20	CPI 22 CPE 22	CPI 24 CPE 24	CPI 26 CPE 26	CPI 28 CPE 28	CPI 30 CPE 30	CPI 32 CPE 32	CPI 34 CPE 34	CPI 36 CPE 36
Input	MJ/h	4100	4510	4920	5330	5740	6150	6560	6970	7380
Recovery Rate at 50°C rise	L/hr	16460	18106	19752	21398	23044	24690	26336	27982	29628
Maximum Flow Rate at 50°C rise	L/min	274.0	301.4	328.8	356.2	383.6	411.0	438.4	465.8	493.2
Approx Weight	kg	780	850	920	990	1060	1130	1200	1270	1340
Cold Water/Hot Water										
7-12: Threaded Connection	BSPF	-	-	-	-	-	-	-	-	-
14-36: Table E Flanged End	mm	65	80	80	80	80	100	100	100	100
Return	BSPF	RP2¼	RP1½	RP1½	RP1½	RP1½	RP2	RP2	RP2	RP2
Gas	BSPM	R2½	R2½	R2½	R2½	R2½	R2½	R2½	R3	R3
Electrical Supply (240V/50Hz)	Amps	-	-	-	-	-	-	-	-	-
Electrical Supply (415V/3 phase/50Hz)	Amps	13.0	14.0	14.0	14.0	15.0	17.0	17.0	17.0	17.0
Dimensions										
Width - inline	mm	-	-	-	-	-	-	-	-	-
Width - back to back	mm	4390	4750	5110	5470	5830	6190	6550	6910	7270
Frost Protection		Yes	Yes	Yes	Yes	Yes	Yes	Yes	Yes	Yes
Relief Valve Setting	kPa	1000	1000	1000	1000	1000	1000	1000	1000	1000
Water Supply Pressure										
Minimum/Maximum	kPa	140/800	140/800	140/800	140/800	140/800	140/800	140/800	140/800	140/800

Back to back 7 - 36 Commpak Plus® Side view

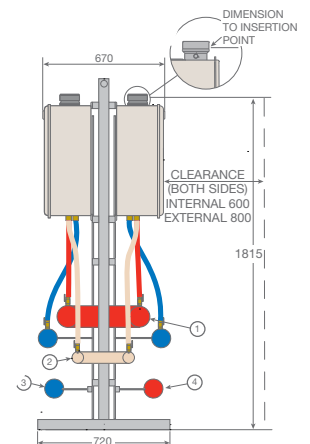

Back to back 7 - 36 Commpak Plus®

Plan view

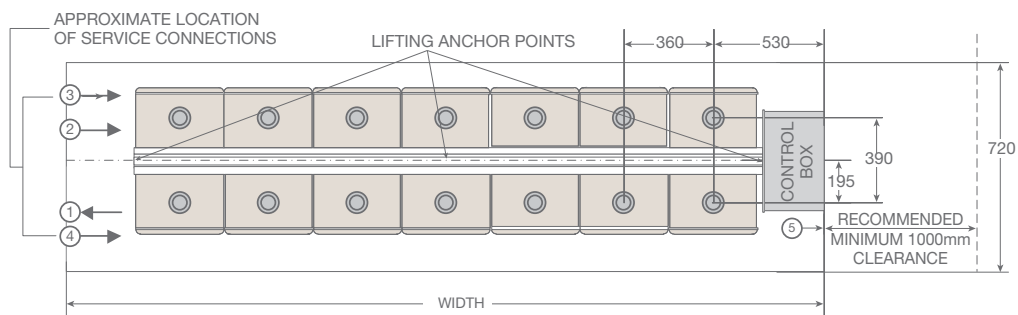

- ① HOT WATER OUTLET
- ② GAS
- ③ COLD WATER INLET
- ④ HOT WATER RETURN
- ⑤ PRESSURE RELIEF VALVE OUTLET

INDOOR INSTALLATION TIPS

Here's a guide to selecting the flue components you need:

- The overall dimension of each flue piece is shown in the drawings.
- Allow approximately 35mm for insertion of each flue piece.
- Determine the lineal distance and number of 45° and/or 90° bends between the top of the water heater and flue terminal. Note: the bottom edge of a vertical flue terminal must be 500mm away from the nearest structure in accordance with AS/NZS 5601.1.
- Flashing is required to be installed where a vertical flue section penetrates the roof line (not supplied).
- Where required, a condensate trap must be installed and filled with water to prevent spillage of products of combustion, and the hose drained to the sewer or outside.
- Separate ventilation for combustion is not required, as the air for combustion is supplied in the flue outer.
- The flue system is certified to be installed with zero clearances between the water heaters and combustible materials.
- Flue termination must comply with the requirements of AS/NZS 5601.1.
- Flue penetrations through walls and ceilings must be sealed in accordance with local fire regulations.
- The maximum flue length with no bends is 13.5m. Reduce the maximum length by 1.5m for every 90° bend and by 0.75m for every 45° bend.
- The flue system is suitable for vertical and horizontal termination when used with the appropriate terminal.

Horizontal terminal adjacent wall

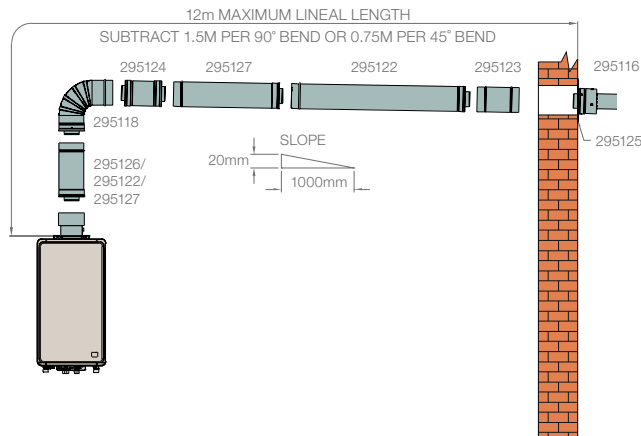

Vertical Terminal

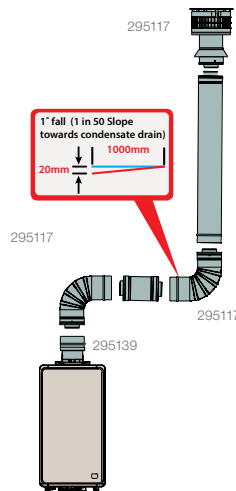

Direct vent horizontal wall

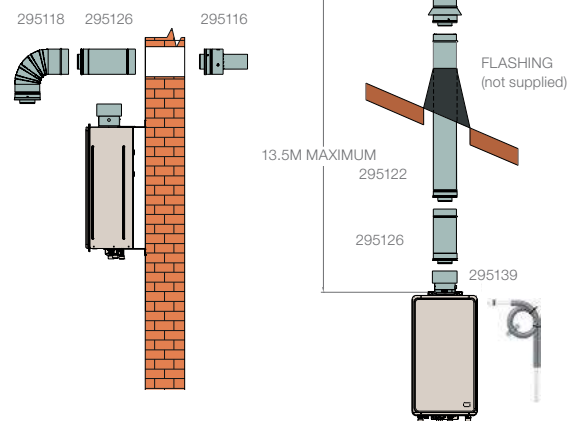

Continuous Flow Flue Kits

Use the following table as a guide for selecting a Rheem 27 Indoor Continuous Flow flue kit. Please note these are base kits only. Further components may be necessary for some installations.

PART NO.	DESCRIPTION	KIT INCLUDES	KIT LENGTH
318280	Vertical Flue Kit	1 x Vertical Terminal (295117)	1200mm
		1 x Straight Length 900mm (295122)	
		1 x Trim Ring (295125)	
		1 x Condensate Trap (295139)	
318278	Horizontal Flue Kit Side Exit	1 x Horizontal Terminal (295116)	1320mm
		2 x Trim Ring (295125)	
		1 x Straight Length 900mm (295122)	
		1 x 90° Bend (295118)	
318279	Horizontal Flue Kit Rear Exit	1 x Horizontal Terminal (295116)	720mm
		2 x Trim Ring (295125)	
		1 x Straight Length 300mm (295126)	
		1 x 90° Bend (295118)	



Rheem INTERNAL CFWH must only be installed using certified Rheem coaxial flue components.

Do not use any other type of flue system. Carefully follow the installation instructions.

FLUE COMPONENTS

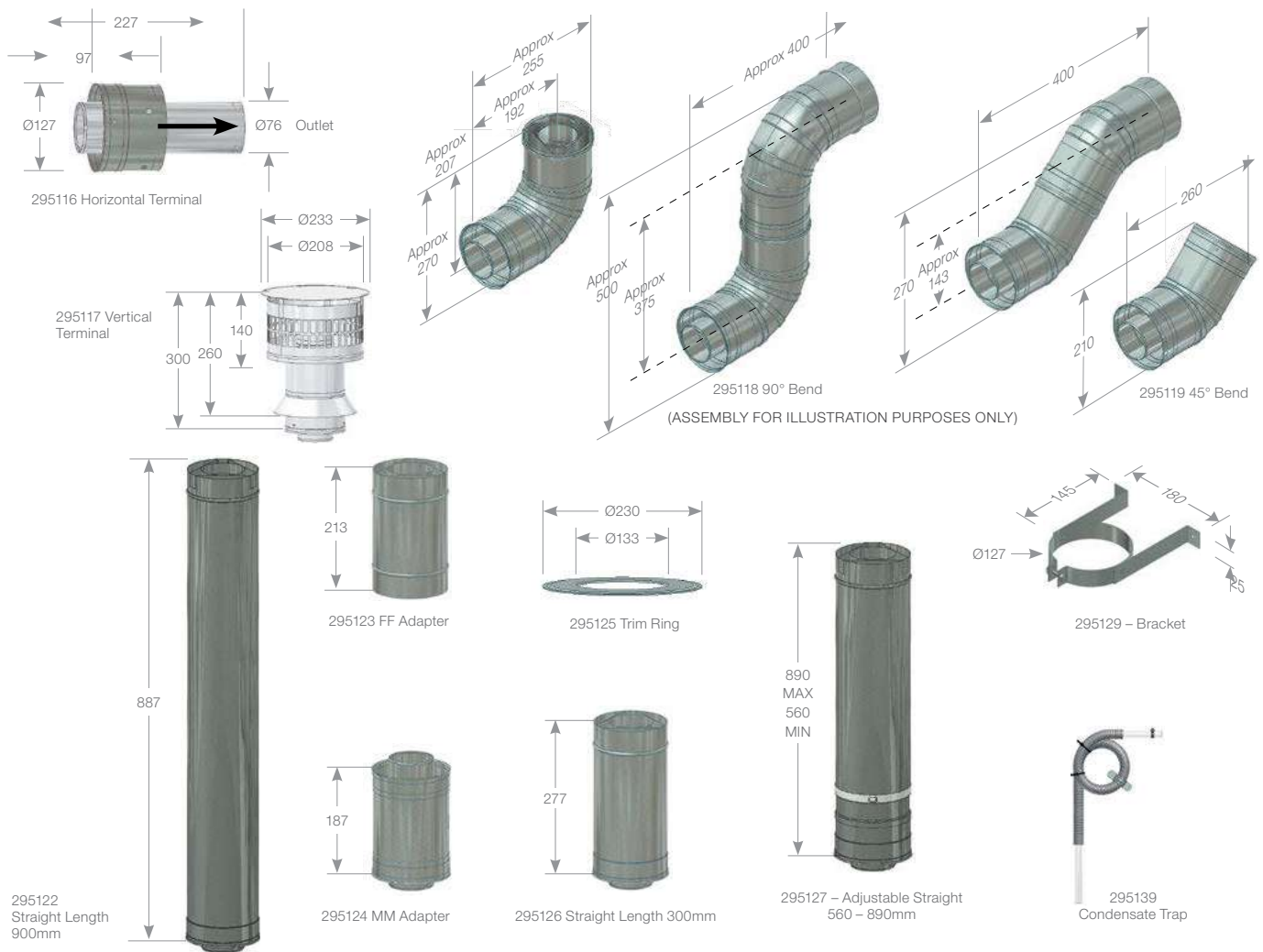

Use the following table as a guide to selecting Rheem Continuous Flow flue components:

P/NO	DESCRIPTION	WHERE USED
295116	Horizontal Terminal	Required where flue terminates horizontally or vertically
295117	Vertical Terminal	Required where flue terminates vertically
295118	90° Bend	Maximum of 5 per installation
295119	45° Bend	Maximum of 10 per installation (with no 90° bends)
295122	Straight Length 900mm	Long straight sections
295123	Female Female Adapter	Required to reverse flue pipe direction to allow condensate to drain away correctly from water heater in long horizontal sections of horizontally terminating flues
295124	Male Male Adapter	Required to reverse flue pipe direction to allow condensate to drain away correctly from water heater in long horizontal sections of horizontally terminating flues
295125	Trim Ring (optional)	Conceal internal and/or external hole in wall for horizontally terminating flues
295126	Straight Length 300mm	Short straight sections
295127	Adjustable Length 560 – 890mm	Allows to trim flue to exact length required
295129	Bracket	Support flue at intervals not exceeding 2m and after any bend
295139	Condensate Trap	Required with every condensate drain. Can be connected to a common waste

CO-AXIAL FLUE SPECIFICATION	MATERIAL/DIAMETER
Inner flue	316 or 444SS/75
Outer flue	Aluminised Steel/125

HEAVY DUTY GAS STORAGE

The workhorse hot water system that keeps on working, in a wider range of water quality environments.

We have used Rheem Heavy Duty Gas in many situations.

Very happy with the performance and durability and would recommend them as a reliable workhorse.

John Lewis, Maintenance Manager -
Chadoak Pty Ltd

CASE STUDY

ADVANTAGED CARE AT PRESTONS LODGE

Challenge

Prestons Lodge is a 132-bed aged care facility built in 2016 by Advantaged Care. With a daily hot water load of 9175 litres, the challenge was to provide energy efficient, budget-conscious options for the hot and warm water plant requirements.

Hot Water Solution

Approached during the design stage, Rheem provided an energy efficient solar and warm water proposal that included budget estimates and pay back periods.

The final installed solution included:

- 3 x Heavy Duty Gas water heaters,
- 38 x NPT solar collectors and
- 14 x storage tanks along with
- 1 x 240L/min Guardian warm water and 2 x 250L/min ultraviolet disinfection.



HEAVY DUTY GAS STORAGE

SUITED TO ALL APPLICATIONS IN ANY POTABLE WATER



IMPERVIOUS



FAST REPLACEMENT

EASY TO MAINTAIN



HEATS WATER UP TO

82°C

The workhorse hot water system that keeps on working, in most water chemistries.

Highly reliable and impervious to a wider range of water types

A staple of the market for over 25 years, the storage cylinder is made from a special grade of steel, lined with a double coat of heavy duty vitreous enamel, and incorporates multiple anodes, by making it impervious to the widest variety of water chemistries.

Gold-standard redundancy and easy to maintain

As each unit is standalone, the failure of a single component doesn't render the entire system offline. The simple design combines the burner and the tank without the need for pumps, making it more reliable and easy to maintain.

Multiple installation options

There are three sizes in outdoor and indoor versions, and indoor models can be flued individually or joined into a common flue.

Accurate and reliable temperature management

Electronic thermostat provides fine temperature control with digital setting display on the 265 and 275. Hot Surface Ignition (HSI) removes the need for a pilot light, lowers operating costs and improves reliability because of a built-in 100% flame failure control.

Reduces energy use

The flue damper on the 624275 indoor closes off the primary flue when the burner isn't operating, reducing maintenance rates by up to 60% when compared to AGA maximum allowance.



More key features

- Sizes include 260 (51MJ), 265 (110MJ), 275 (200MJ)
- No electrical connection required for the smallest unit (260)
- BMS capable with the addition of a module - 265 and 275 models

Heavy Duty Gas Storage warranty: 5 years on cylinder, 1 year on parts & labour

TECHNICAL DATA

DIMENSIONS AND TECHNICAL DATA TABLE			OUTDOOR MODELS			INDOOR MODELS		
Model			630260N0*	634 265	634 275	620260N0	624 265	624 275
Storage Capacity	litres		260	265	275	260	265	275
Dimensions								
	A	mm	1640	1835	1865	1660	1795	1895
	B	mm	590	610	640	590	610	640
	C	mm	680	710	780	670	750	780
	D	mm	990	750	760	990	750	760
	E	mm	330	700	700	330	700	700
	F	mm	295	380	340	297	380	340
	G	mm	1520	1655	1695	1520	1655	1695
	H	degrees	27	36	36	27	36	36
	K	mm	655	660	722	655	660	722
	L	mm	295	302	320	295	302	320
	M	mm	–	–	–	100	125	200
	P	mm	420	420	320	–	–	–
Weight – Empty	kg		110	132	197	101	129	187
Inlet/Outlet Connections (BSPF)			RP1¼	RP1¼	RP1¼	RP1¼	RP1¼	RP1¼
Gas Connection (BSPF)			RP½	RP¾	RP¾	RP½	RP¾	RP¾
T&PR Valve Connection (BSPF)			RP¾	RP¾	RP¾	RP¾	RP¾	RP¾
T&PR Valve Setting	kPa		1000	1000	1000	1000	1000	1000
Expansion Control Valve (ECV)* Setting	kPa		850	850	850	850	850	850
Max. Water Supply Pressure								
without ECV* fitted	kPa		800	800	800	800	800	800
with ECV* fitted	kPa		680	680	680	680	680	680
Max. Thermostat Setting	°C		65	82	82	65	82	82
Factory Thermostat Setting	°C		60	70	70	60	70	70
Min. Thermostat Setting	°C		off	60	60	off	60	60
Manifold – Min. Centre to Centre	mm		920	920	890	845	860	890
Electrical Connection			–	2m 10A Plug and Lead		–	2m 10A Plug and Lead	
Electrical Rating 240V 50Hz			–	150 Watts	250 Watts	–	150 Watts	150 Watts
				0.65 Amps	1.1 Amps		0.65 Amps	0.65 Amps
Maintenance Rate	MJ/day		30.7	42.7	50.7	33.9	53.3	26.1

*Expansion control valve not supplied with water heater.

Outdoor Models

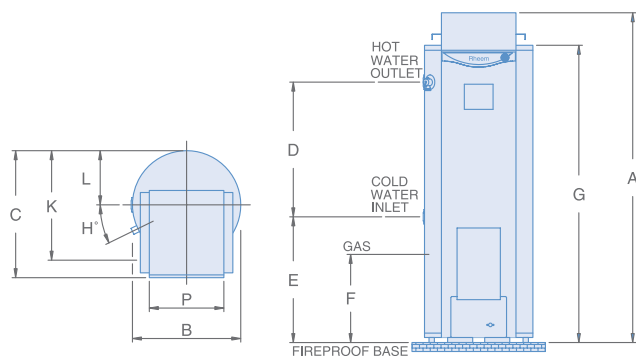

Indoor Models

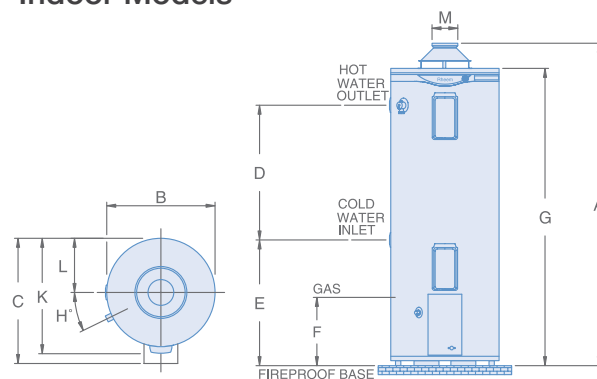

TECHNICAL DATA

PERFORMANCE DATA									
Model	No. of Units in Parallel	Initial Storage Capacity (Litres)	Thermal Input (MJ/h)	Litres hot water at 50°C rise over peak period (based on natural gas)					
				1 hour	2 hours	3 hours	4 hours	6 hours	8 hours
620260N0 & 630260N0	1	260	51	380	570	760	950	1330	1700
	2	520	102	770	1140	1520	1900	2650	3410
	3	780	153	1150	1720	2280	2850	3980	5110
624 265 & 634 265	1	265	110	620	1030	1440	1850	2670	3490
	2	530	220	1240	2060	2880	3700	5340	6980
	3	795	330	1870	3100	4330	5560	8010	10470
624 275 & 634 275	1	275	200	970	1710	2460	3200	4690	6180
	2	550	400	1930	3420	4910	6400	9380	12370
	3	825	600	2900	5130	7370	9600	14080	18550
	4	1100	800	3860	6840	9820	12810	18770	24730
	5	1375	1000	4830	8550	12280	16010	23460	30910
	6	1650	1200	5790	10260	14740	19210	28150	37100
Model	No. of Units in Parallel	Initial Storage Capacity (Litres)	Thermal Input (MJ/h)	Litres hot water at 65°C rise over peak period (based on natural gas)					
				1 hour	2 hours	3 hours	4 hours	6 hours	8 hours
624 265 & 634 265	1	265	110	530	840	1160	1470	2100	2730
	2	530	220	1050	1690	2320	2950	4210	5470
	3	795	330	1580	2530	3470	4420	6310	8200
624 275 & 634 275	1	275	200	790	1370	1940	2510	3660	4810
	2	550	400	1590	2730	3880	5030	7320	9610
	3	825	600	2380	4100	5820	7540	10980	14420
	4	1100	800	3170	5470	7760	10050	14640	19230
	5	1375	1000	3970	6830	9700	12570	18300	24030
	6	1650	1200	4760	8200	11640	15080	21960	28840

Note: Hot water figures rounded to the nearest 10 litres.

Operations at temperature above 80°C

Rheem commercial gas models 624 265, 634 265, 624 275, 634 275 are designed to operate at temperatures up to 82°C for sanitising and other applications.

Where the water supplied by the water heater is required consistently at any temperature above 80°C, we strongly recommend you use a pumped recirculation system. (Please refer to the Equa-Flow® section.)

Gas pipe supply

The gas supply piping should be sized in accordance with AS/NZS 5601.1.

The gas supply pipe must be sized so that the minimum gas pressure is available at the inlet to each water heater when all appliances are operating at maximum gas consumption.

The minimum gas pressures are 1.13 kPa for Natural GAS and 2.75 kPa for ULPG.

TECHNICAL GAS PERFORMANCE DETAILS							
Model		620260N0 & 630260N0		624 265 & 634 265		624 275 & 634 275	
Gas Type		Nat	ULPG*	Nat	ULPG*	Nat	ULPG*
Thermal Input	MJ/h	51	58	110	117	200	210
Output	kW	11	11.0	23.8	25	43.3	45.5
Min. Gas Supply Pressure	kPa	1.13	2.75	1.13	2.75	1.13	2.75
Test Point Pressure	kPa	1.0	2.7	0.9	2.5	0.90	2.65
Max. Gas Supply Pressure	kPa	3.5	3.5	3.5	3.5	3.5	3.5
Litres Recovery Per Hour at Rise of	20°C	480	490	1030	1098	1870	1968
	30°C	320	330	690	738	1250	1314
	40°C	240	250	520	552	940	984
	50°C	190	195	410	444	750	786
	60°C	160	165	350	372	630	660
	65°C	150	154	320	342	580	606
	70°C	140	144	300	318	540	564
75°C	130	133	280	294	500	528	

* Based on NZ ULPG 60/40 mix

HEAVY DUTY GAS BMS INTERFACE MODULES

The Rheem Heavy Duty Gas BMS interface module is designed to interface between individual gas water heaters and the building management system to remotely provide facility managers with real-time water heater status.

Features

- The module mounts to the outside of the water heater and is provided with Common, N/O and N/C contacts for field connection by on site trades
- Suits models 624265, 624275, 634265, 634275
- Provides Run/Fail signal via voltage free contacts (common, N/O, N/C)
- Contact rating 1A @ 48V
- Uses water heater's own power supply
- Suitable for indoor and outdoor installation – IP34
- On board LED status
- Suitable for new installations or retrofit to existing heaters
- Dimensions (mm): 231(h) x 112 (w) x 78 (d)
- Order Code: 299239



INDICATOR CODE	
GREEN	Normal Operation (Relay Energised)
RED OR NO INDICATION	Attention Required (Relay de-energised)
Voltage Free Contact Load: Max 1A, 48V	

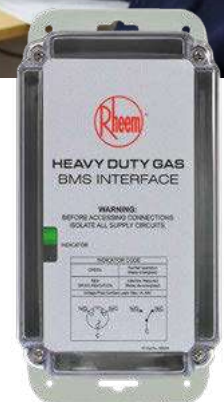

VENTILATION AND FLUEING

Ventilation for indoor gas water heaters

In Australia and New Zealand, gas water heaters installed indoors (non-room sealed) require to be ventilated in accordance with AS5601 or AS/NZS 5601.1 depending on the local regulations.

AS/NZS 5601.1 also has further requirements regarding compliance of mechanical ventilation.

Please consult the appropriate standard when designing plant room ventilation requirements.

Notes

1. Although a room sealed water heater installation draws the air required for combustion from outside, ventilation may be necessary to prevent a rise in the ambient temperature in the room.
2. In plant rooms, wherever possible, more than one wall should be used to provide ventilation. This allows a flow of air across the room and helps prevent excessive temperatures in the room.
3. In rooms other than plant rooms, ventilation is required if the total thermal input of the water heaters exceeds 3 MJ/h per cubic metre of room volume.

Power flueing / Mechanical ventilation

You can either install an individual Rheem gas model or a bank of multiple 624 265, 624 275 models with a power flue or mechanical air supply.

It's essential to prove the flue system operates correctly before the main burner is allowed to operate.

How is this achieved? A self proving relay interlocked with either a vane switch or pressure differential switch will prove both air flow and functionality of the control circuit before ignition of the main burner.

Please refer to AS/NZS 5601.1 for full details of what's required.

For multiple installations, the operating principle is the same as for a single water heater.

Any water heater can switch on the fan, and the burners can only come on when the sail switch is closed.

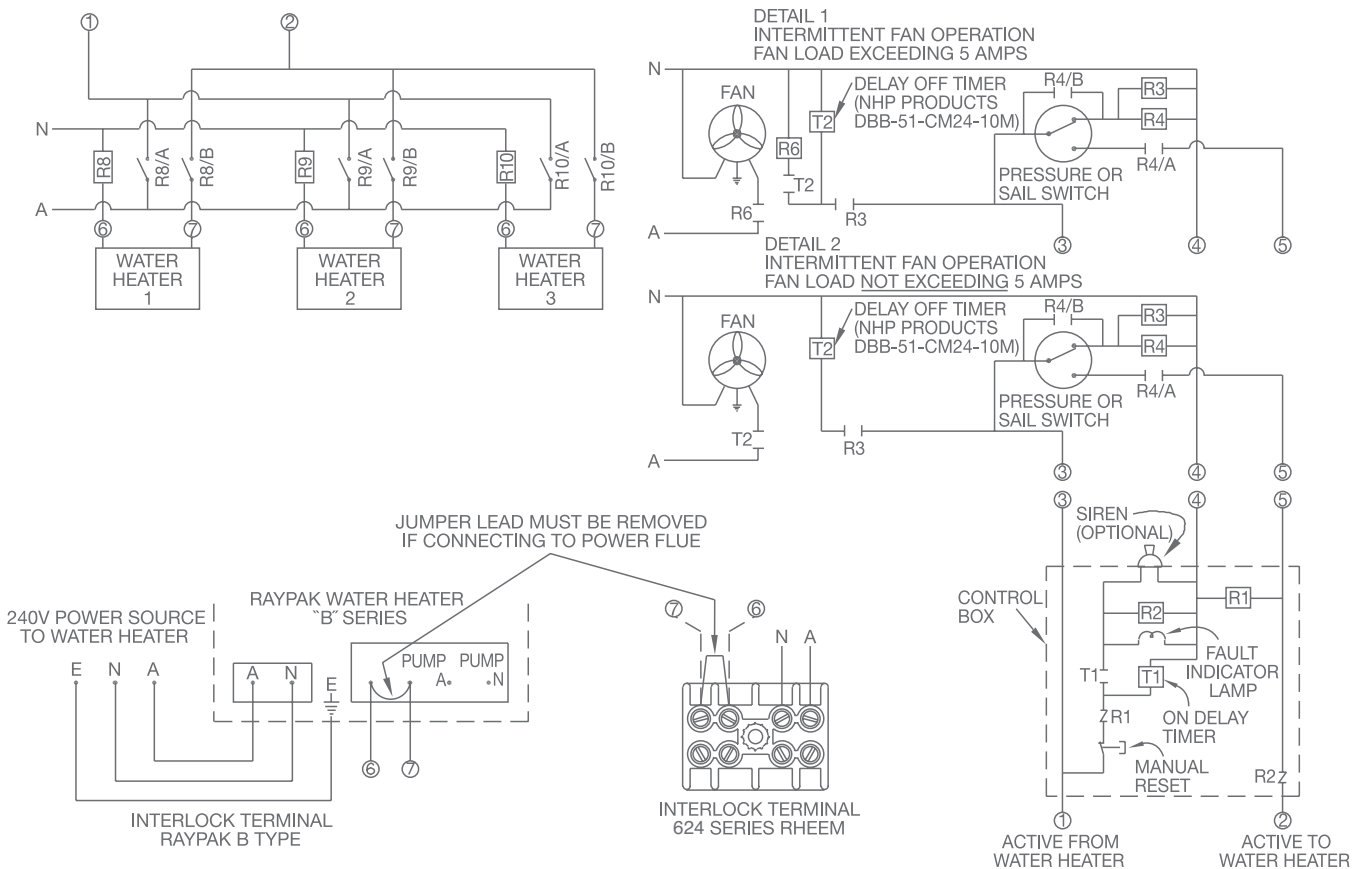

Intermittent PowerFlue Fan Control – Multiple Water Heater Rheem 624 Series & Raypak Type B Series.

TECHNICAL DATA

Power Flue and Remote control

Rheem commercial models 624 265, 634 265, 624 275, 634 275 may be controlled by a remote device such as a time clock, BMS remote isolating switch, pressure switch or sail switch. Additionally, Rheem can assist with Power Flue design solutions for Rheem and Raypak® commercial gas water heaters. Please contact your local Rheem technician service team for further details.

Flueing: minimum distances for outdoor gas water heaters

Rheem outdoor gas water heaters have a balanced flue and do not require the addition of secondary flueing. Minimum clearance requirements, as stated in AS/NZS 5601.1, apply to the location of outdoor balanced flue, room sealed or power flue terminals.

The Standard also states that where a balanced flue or room sealed terminal is installed under a covered area, the covered area is to be open on at least two sides and the terminal is to be located to ensure a free flow of air across the terminal.

Flueing: indoor gas water heaters

Manifolded water heaters can either be flued individually or connected to a common flue. The design of the flue must comply with Appendix H of the Standard.

AS/NZS 5601.1 states the vertical rise directly out of the water heater must be the maximum possible height before any change in direction.

The total length of the lateral (horizontal) section must be as short as possible, not exceeding 50% of the total flue height of the system.

The table and diagram below are extracted from the Flue Tables in AS/NZS 5601.1 and are meant as a quick guide only. Any variations should be referenced from AS/NZS 5601.1.



Appropriate authorities should be consulted before any work is commenced on flues other than single appliance flues.



Additionally, Rheem requires the water heater be installed with the back of the unit against a wall, or alternatively against a solid fireproof screen, extending at least 500mm above, below and either side of the flue terminal.



Rheem indoor gas water heaters are designed for connection to a flue system in accordance with the requirements of AS/NZS 5601.1.

Multiple Manifold Flue System

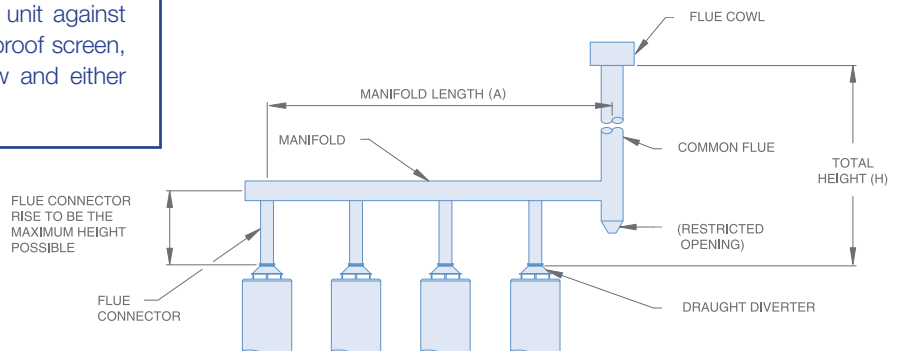

Notes: The length of manifold "A" should not exceed 50% of total flue height "H".

FLUE SIZING FOR GAS WATER HEATERS

Model	Total Flue Height (H) (m)	1		2		4		6		8	
		Max. Lateral (m)	Flue Dia (mm)	Max. Manifold Length (A) (m)	Flue Dia (mm)	Max. Manifold Length (A) (m)	Flue Dia (mm)	Max. Manifold Length (A) (m)	Flue Dia (mm)	Max. Manifold Length (A) (m)	Flue Dia (mm)
620260N0	2	1.0	100	1.0	150	–	–	–	–	–	–
51 MJ/h	3	1.5	100	1.5	125	–	–	–	–	–	–
	6	3.0	100	3.0	125	3.0	175	–	–	–	–
	12	6.0	100	6.0	100	6.0	150	6.0	175	–	–
	24	7.6	150	12.0	150	12.0	150	12.0	175	12.0	200
624 265	2	1.0	150	1.0	200	–	–	–	–	–	–
	3	1.5	125	1.5	200	–	–	–	–	–	–
	6	3.0	125	3.0	175	3.0	250	–	–	–	–
	12	6.0	125	6.0	150	6.0	200	6.0	250	–	–
624 275	2	1.0	175	1.0	300	–	–	–	–	–	–
	3	1.5	175	1.5	250	–	–	–	–	–	–
	6	3.0	150	3.0	250	3.0	300	–	–	–	–
	12	6.0	150	6.0	200	6.0	300	6.0	350	–	–
200 MJ/h	24	7.6	150	12.0	200	12.0	250	12.0	300	12.0	350

Notes: • The table is based on a natural draft system with an insulated type flue or a flue installed indoors.
• The table is extracted from the Flue Tables in AS/NZS 5601.1 and is meant as a quick guide only. Any variations should be referenced from AS/NZS 5601.1

RAYPAK® HEATING & HOT WATER

The industrial duty hot water system providing extreme durability.

We use and recommend Raypak water heaters for the Dousta Gala Aged Care facility network for their exceptional hot water delivery performance, and outstanding durability.

Harry Phillipou, Phillipou Plumbing

CASE STUDY

MERITON INFINITY TOWER

Challenge

One of Brisbane's tallest residential towers at 249 metres with 81 levels, Infinity Tower offers stunning ocean and hinterland views to hundreds of luxury managed and residential apartments. The requirement was to provide high volumes of hot water, with a minimal footprint.

Hot Water Solution

Two plant rooms each provide centralised hot water supply to two separate zones in the building.

The level 79 Plantroom houses 2 x Raypak heaters (natural draught flues) with 6 x Rheem Commercial Storage Tanks, providing up to 15,532 litres at 50°C rise in the first hour, servicing 287 apartments from levels 25 to 64.

The level 25 Plantroom houses 2 x Raypak heaters (power flued) with 6 x Rheem Commercial Storage Tanks provides up to 10,200 litres at 50°C rise in the first hour, servicing 199 apartments from level 2 to 24.



Raypak® is a compact, efficient heating design, which is the ideal way to heat large quantities of water for both hot water and hydronic applications.

Highly reliable

In the market for 50 years, Raypak's direct fired, bronze headers and pure copper-finned heat exchangers resist the combined effects of corrosion and high temperature.

Constant hot water and hydronic heating

Operating on mains pressure, on/off models deliver constant full recovery, and modulating models respond to building load in low pressure heating circuits. On/off models can operate as low as 41°C without any condensation or sooting.

Fast replacement

The atmospheric combustion system and slide-out burner tray make it simple to maintain and repair, and the unit is readily deconstructed on site to allow for retrofit access.

Highly efficient

Raypak's copper tube construction is highly responsive with an outstanding 82% thermal



efficiency. The ceramic fibre refractory panels insulate the system with an interlocking design reducing heat loss. High MJ/m² allowing for space saving installation flexibility.

Withstands high temperatures

Robust materials mean modulating units can provide up to 90°C, ideal for sanitising and industrial process applications.

BMS connectivity

Run and fail monitoring (available on Type B models).

More key features:

- Selected models are available in ULPG
- Left-hand (normal) or right-hand water and gas connections available
- Water flow switch (Type B models)
- Heaters can be plumbed together for redundancy
- On/off models are suitable for domestic hot water applications
- Modulating models are suitable for hydronic applications

RayPak® warranty: 5 years on heat exchanger parts, 1 year on heat exchanger labour,
1 year on parts & labour

TECHNICAL DATA

Models 200, 280, 350, 430 (Indoor/Outdoor)

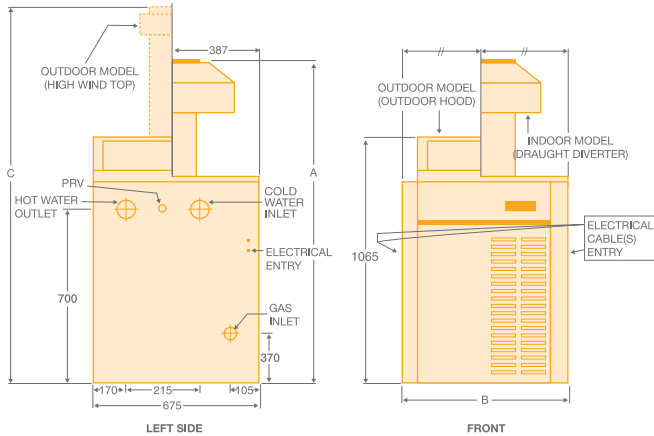

Models 538, 658, 768 & 868 (Indoor/Outdoor)

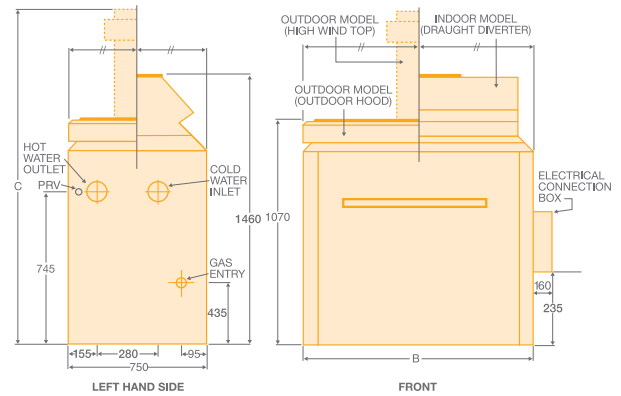

DIMENSIONS AND TECHNICAL DATA TABLE – INDOOR/OUTDOOR MODELS

Model		200	280	350	430	538	658**	768	868
Natural – Input	MJ/h	196	278	343	420	539	661	765	870
– Output	kW	44	62	76	94	120	150	170	195
ULPG – Input	MJ/h	185	261	323	396	–	620	–	–
– Output	kW	41	58	72	88	–	140	–	–
Dimensions									
A	mm	1,625	1,715	1,715	1,805	–	–	–	–
B	mm	465	570	655	745	830	955	1,055	1,160
C	mm	1,955	2,240	2,035	2,145	2,130	2,255	2,255	2,355
Flue Connection	mm	175	205	225	255	255	305	305	355
Weight	kg	91	93	103	107	195	200	250	260
Inlet/Outlet Connections		RC1½	RC1½	RC1½	RC1½	RC2½	RC2½	RC2½	RC2½
Gas Connection									
Natural – On / Off Models		NA	RP¾	RP¾	RP¾	R1	R1½	R1½	R1½
Natural – Modulating Models		RP1	RP1	RP1	RP1	R1	R1	R1½	R1½
ULPG – On / Off Models		NA	RP¾	RP¾	RP¾	–	R1/25	–	–
ULPG – Modulating Models		RP¾	RP¾	RP¾	RP¾	–	R¾/20	–	–
Relief Valve Connection									
On/Off models		NA	RC¾	RC¾	RC¾	RC¾	RC¾	RC¾	RC¾
Modulating models		RC¾	RC¾	RC¾	RC¾	RC¾	RC¾	RC¾	RC¾
Electrical Rating 240V 50Hz (excluding pump)	Watts	50	50	50	50	50	50	50	50
	Amps	0.21	0.21	0.21	0.21	0.21	0.21	0.21	0.21
Min. Buffer Tank Capacity	Litres	325	325	325	325	325	325	325	325
Max. Storage Capacity	Litres	2,000	3,000	4,000	4,800	6,000	7,500	8,500	10,000
Natural Gas									
Litres Recovery Per Hour @	30°C rise	1,250	1,769	2,187	2,683	3,440	4,300	4,873	5,590
	40°C rise	937	1,327	1,640	2,012	2,580	3,225	3,655	4,193
	50°C rise	750	1,061	1,312	1,610	2,064	2,580	2,924	3,354
	60°C rise	625	884	1,094	1,342	1,720	2,150	2,437	2,795
	65°C rise	577	816	1,010	1,238	1,588	1,985	2,249	2,580
	70°C rise	536	758	937	1,150	1,474	1,843	2,089	2,396
	75°C rise	500	708	875	1,073	1,376	1,720	1,949	2,236
	80°C rise	469	663	820	1,006	1,290	1,613	1,828	2,096
	85°C rise	441	624	772	947	1,214	1,518	1,720	1,973
Flow Rate and Pressure Drop									
Max. Flow Rate									
Modulating (10°C Rise)*	L/s	1.04	1.47	1.82	2.24	2.87	3.58	4.06	4.66
Pressure Drop	kPa	3	8	13	17	6	10	14	22
Max. Flow Rate									
On/Off (15°C Rise)*	L/s	0.69	0.98	1.22	1.49	1.91	2.39	2.71	3.11
Pressure Drop	kPa	3	4	6	8	3	4	6	8
Min. Flow Rate									
(20°C rise)*	L/s	0.52	0.74	0.91	1.12	1.43	1.79	2.03	2.33
Pressure Drop	kPa	3	3	3	4	3	3	4	5

*Guide only.

** ULPG model indoor only.

TECHNICAL DATA

Models 992, 1182, 1292, 1412, 1722, 1922 (Indoor)

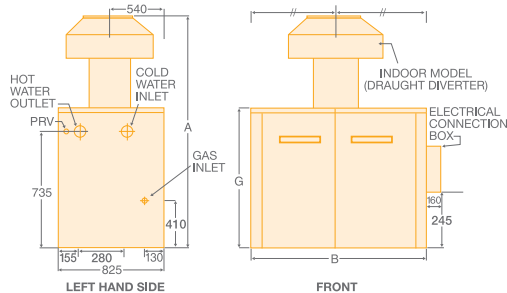

Models 2214, 2634, 3164, 3694, 4224 (Indoor)

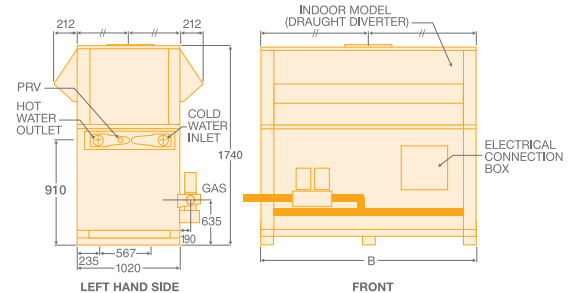

DIMENSIONS AND TECHNICAL DATA TABLE – INDOOR MODELS

Model		992	1182	1292	1412	1722	1922	2214	2634	3164	3694	4224
Natural – Input	MJ/h	999	1,186	1,289	1,412	1,719	1,926	2,215	2,636	3,165	3,692	4,224
– Output	kW	225	265	285	315	380	430	505	600	720	840	960
ULPG – Input		933	–	–	1,296	–	1,772	–	–	–	–	–
– Output		205	–	–	290	–	395	–	–	–	–	–
Dimensions												
A	mm	1,810	1,915	1,915	1,990	2,060	2,130	–	–	–	–	–
B	mm	1,330	1,510	1,615	1,740	2,070	2,270	1,550	1,780	2,060	2,350	2,640
G	mm	860	860	860	860	930	930	–	–	–	–	–
Flue Connection	mm	355	405	405	455	455	505	610	660	710	760	815
Weight	kg	310	330	360	390	440	460	625	700	780	860	940
Inlet/Outlet Connections		RC2½	RC2½	RC2½	RC2½	RC2½	RC2½	RC3	RC3	RC3	RC3	RC3
Gas Connection												
Natural – On / Off Models		R1½	R1½	R1½	R1½	R2	R2	R2	R2½	R2½	R3	R3
Natural – Modulating Models		R1½	R1½	R1½	R1½	R2	R2	R2	R2½	R2½	R3	R3
ULPG – On / Off Models		R1¼32		R1¼32		R1½40						
ULPG – Modulating Models		R¾20		R1/25		R1½40						
Relief Valve Connection												
On/Off Models		RC¾	RC¾	RC¾	RC¾	RC¾	RC¾	RC¾	RC¾	RC1	RC1	RC1
Modulating Models		RC¾	RC¾	RC¾	RC¾	RC1	RC1	RC1¼	RC1¼	RC1½	RC1½	RC1½
Electrical Rating 240V 50Hz (excluding pump)	Watts	100	100	100	100	100	100	100	100	100	100	100
	Amps	0.42	0.42	0.42	0.42	0.42	0.42	0.42	0.42	0.42	0.42	0.42
Min. Buffer Tank Capacity	Litres	387	456	490	542	654	740	869	824	990	1,156	1,320
Max. Storage Capacity	Litres	11,000	13,000	14,500	16,000	19,500	22,000	27,000	31,000	37,000	43,500	49,500
Natural Gas												
Litres Recovery Per Hour @	30°C rise	6,450	7,597	8,170	9,030	10,893	12,327	14,477	17,200	20,640	24,080	27,520
	40°C rise	4,838	5,698	6,128	6,773	8,170	9,245	10,858	12,900	15,480	18,060	20,640
	50°C rise	3,870	4,558	4,902	5,418	6,536	7,396	8,686	10,320	12,384	14,448	16,512
	60°C rise	3,225	3,798	4,085	4,515	5,447	6,163	7,238	8,600	10,320	12,040	13,760
	65°C rise	2,977	3,506	3,771	4,168	5,028	5,689	6,682	7,939	9,526	11,114	12,702
	70°C rise	2,764	3,256	3,501	3,870	4,669	5,283	6,204	7,372	8,846	10,320	11,794
	75°C rise	2,580	3,039	3,268	3,612	4,357	4,931	5,791	6,880	8,256	9,632	11,008
	80°C rise	2,419	2,849	3,064	3,386	4,085	4,623	5,429	6,450	7,740	9,030	10,320
	85°C rise	2,276	2,681	2,884	3,187	3,845	4,351	5,109	6,071	7,285	8,499	9,713
Flow Rate and Pressure Drop												
Max. Flow Rate												
Modulating (10°C rise)*	L/s	5.38	6.31	6.31	6.31	6.31	6.31	12.06	12.62	12.62	12.62	12.62
Pressure Drop	kPa	29	44	46	49	55	58	48	49	50	54	57
Max. Flow Rate												
On/Off (15°C rise)*	L/s	3.58	4.22	4.54	5.02	6.05	6.31	8.04	9.56	11.47	12.62	12.62
Pressure Drop	kPa	12	18	24	30	51	58	20	28	38	54	57
Min. Flow Rate												
(20°C rise)*	L/s	2.69	3.17	3.40	3.76	4.54	5.14	6.03	7.17	8.60	10.03	11.47
Pressure Drop	kPa	7	11	14	18	30	39	12	17	23	30	42

*Guide only.

TECHNICAL DATA

Models 972, 1142, 1242, 1362, 1662, 1852 (Outdoor)

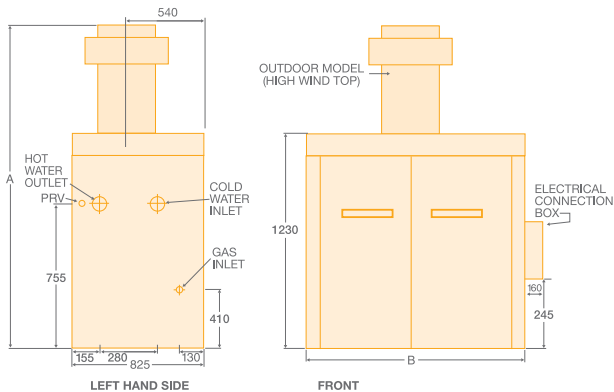

Models 2004, 2404, 2804*, 3304*, 3804* (Outdoor)

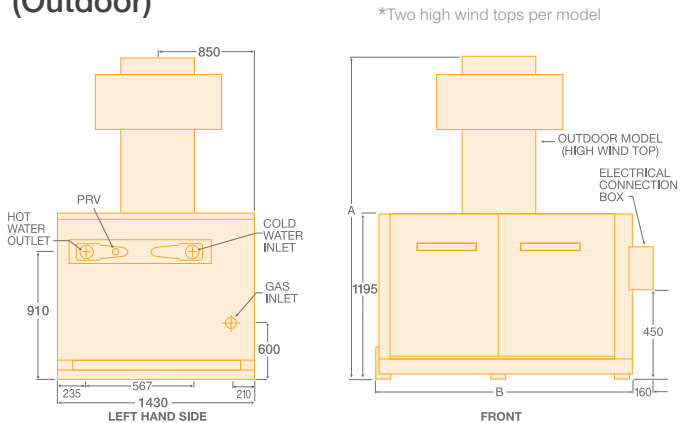

DIMENSIONS AND TECHNICAL DATA TABLE – OUTDOOR MODELS

Model		972	1142	1242	1362	1662	1852	2004	2404	2804	3304	3804
Natural – Input	MJ/h	976	1,142	1,242	1,357	1,657	1,854	2,004	2,404	2,804	3,304	3,804
– Output	kW	220	255	275	300	370	410	445	530	625	740	845
Dimensions												
A	mm	2,500	2,395	2,395	2,570	2,640	2,920	3,165	3,210	3,185	2,965	3,165
B	mm	1,330	1,510	1,615	1,740	2,070	2,270	1,550	1,780	2,060	2,350	2,635
Weight	kg	360	385	410	440	510	520	650	730	810	890	970
Inlet/Outlet Connections		RC2½	RC2½	RC2½	RC2½	RC2½	RC2½	RC3	RC3	RC3	RC3	RC3
Gas Connection												
Natural – On / Off Models		R1½	R1½	R1½	R1½	R2	R2	R2	RC2½	RC2½	RC2½	R3
Natural – Modulating Models		R1½	R1½	R1½	R1½	R2	R2	R2	RC2½	RC2½	R3	R3
Relief Valve Connection												
On/Off models		RC¾	RC¾	RC¾	RC¾	RC¾	RC¾	RC¾	RC¾	RC1	RC1	RC1
Modulating models		RC¾	RC¾	RC¾	RC¾	RC1	RC1	RC1¼	RC1¼	RC1½	RC1½	RC1½
Electrical Rating 240V 50Hz (excluding pump)	Watts	100	100	100	100	100	100	100	100	100	100	100
	Amps	0.42	0.42	0.42	0.42	0.42	0.42	0.42	0.42	0.42	0.42	0.42
Min. Buffer Tank Capacity	Litres	378	439	473	516	636	705	765	729	860	1,018	1,163
Max. Storage Capacity	Litres	11,000	13,000	14,000	15,500	19,000	21,000	23,000	27,000	32,000	39,000	43,000
Natural Gas												
Litres Recovery Per Hour @	30°C rise	6,307	7,310	7,883	8,600	10,607	11,753	12,757	15,194	17,917	21,214	24,224
	40°C rise	4,730	5,483	5,913	6,450	7,955	8,815	9,568	11,395	13,438	15,910	18,168
	50°C rise	3,784	4,386	4,730	5,160	6,364	7,052	7,654	9,116	10,750	12,728	14,534
	60°C rise	3,153	3,655	3,942	4,300	5,303	5,877	6,378	7,597	8,958	10,607	12,112
	65°C rise	2,911	3,374	3,639	3,969	4,895	5,425	5,888	7,012	8,269	9,791	11,180
	70°C rise	2,703	3,133	3,379	3,686	4,546	5,037	5,467	6,512	7,679	9,092	10,382
	75°C rise	2,523	2,924	3,153	3,440	4,243	4,701	5,103	6,077	7,167	8,485	9,689
	80°C rise	2,365	2,741	2,956	3,225	3,978	4,408	4,784	5,698	6,719	7,955	9,084
	85°C rise	2,226	2,580	2,782	3,035	3,744	4,148	4,502	5,362	6,324	7,487	8,550
Flow Rate and Pressure Drop												
Max. Flow Rate												
Modulating (10°C Rise)*	L/s	5.26	6.09	6.31	6.31	6.31	6.31	10.63	12.62	12.62	12.62	12.62
Pressure Drop	kPa	27	43	46	49	55	58	45	49	53	57	60
Min. Flow Rate												
On/Off (15°C Rise)*	L/s	3.50	4.06	4.38	4.78	5.89	6.31	7.09	8.44	9.95	11.79	12.62
Pressure Drop	kPa	12	18	23	30	49	58	18	28	35	53	57
Min. Flow Rate (20°C rise)*												
	L/s	2.63	3.05	3.28	3.58	4.42	4.90	5.32	6.33	7.47	8.84	10.09
Pressure Drop	kPa	7	10	12	16	27	21	12	17	21	30	42

* Guide only.

TECHNICAL DATA

RAYPAK PIPE SIZE AND PUMP SELECTION CHART

Model	Pump	Phase	Branch Size ID	Minimum Manifold Header/Pump Speed Size Required (mm)			
				1 Unit	2 Units	3 Units	4 Units
	UPS Series						
280	32-80N	1	32mm	32/3	32/3	50/3	65/3
350	32-80N	1	40mm	40/3	50/3	65/3	65/3
430	32-80N	1	40mm	40/3	50/3	65/3	80/3
538	32-80N	1	50mm	50/3	65/3	80/3	100/3
658	32-80N	1	50mm	50/3	80/3	80/3	100/3
768	40-60/2B	1	50mm	50/2	80/2	100/2	100/2
868	40-60/2B	1	65mm	65/2	80/2	100/2	100/3
972 / 992	40-60/2B	1	65mm	65/3	80/3	100/3	125/3
1142 / 1182	50-120FB	1	65mm	65/1	100/1	100/1	125/1
1242 / 1292	50-120FB	1	65mm	65/1	100/2	125/2	125/2
1362 / 1412	50-120FB	1	65mm	65/1	100/2	125/2	125/1
1662 / 1722	50-120FB	1	80mm	80/3	100/3	125/3	150/3
1852 / 1922	50-120FB	1	80mm	80/3	100/3	125/3	150/3
2004 / 2214	50-120FB	1	100mm	100/3	125/3	150/3	200/3
2404	50-120FB	1	100mm	100/3	125/3	150/3	200/3
2634	50-120FB	1	100mm	100/3	125/3	200/3	200/3
2804	80-120FB	3	100mm	100/2	150/2	200/3	200/3
3164	80-120FB	3	100mm	100/2	150/2	200/3	200/3
3304	80-120FB	3	100mm	100/2	150/3	200/3	200/3
3694	80-120FB	3	125mm	125/3	150/3	200/3	-
3804	80-120FB	3	125mm	125/3	150/3	200/3	-
4224	80-120FB	3	125mm	125/3	200/3	-	-

Note: TP series circulator is recommended for hard water areas in lieu of UPS series circulator. Contact Rheem for further information.

Manifold header sizes are minimum requirements for water heater performance.

Pipe and pump sizing is for DHW only system up to 65°C maximum set point. Header pipe sizing is based on a total length of 20m of primary flow and return piping and 20 bends, excluding equa-flow manifolds on storage tanks and Raypaks at 1.2m/sec velocity.

Single Mechanical Heating System

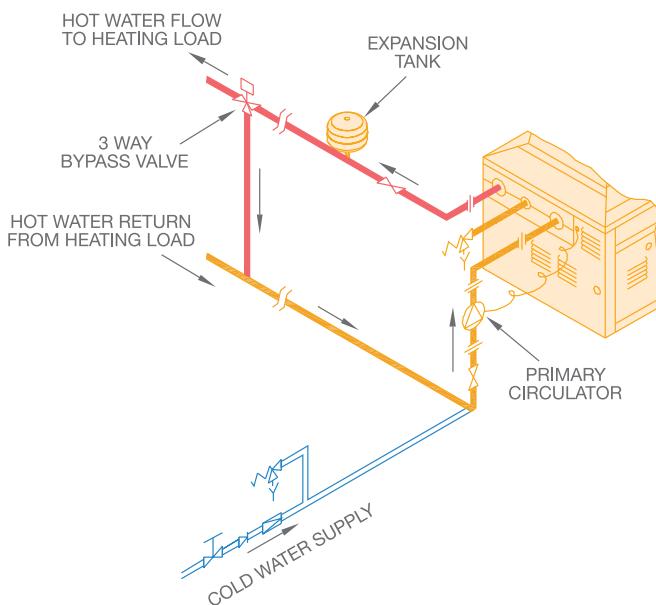

Double Domestic Hot Water System

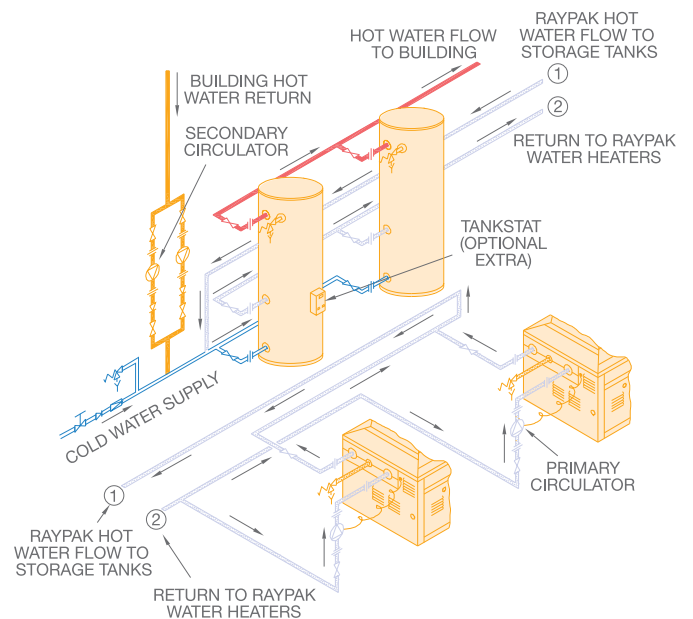

TECHNICAL DATA

ACCESSORIES FOR RAYPAK COMMERCIAL GAS WATER HEATERS

Accessories	Standard	Optional
Pump Run on Timer	All modulating	All On/Off
Tankstat	–	200 to 4224
Hot Surface Ignition (HSI)	200 to 430	–
Electronic Ignition	538 to 4224	–
Water Flow Switch	538 to 4224	–
Relay Run and Fault Status	538 to 4224	–
High Wind Top (outdoor installations only)	538 to 3804	200 to 430
Left Hand Water and Gas Connections	200 to 4224	–
Right Hand Water Connections	–	200 to 430
Right Hand Water and Gas Connections	–	538 to 4224



Raypak® indoor gas water heaters are designed for connection to a flue system in accordance with the requirements of AS/NZS 5601.1.

MINIMUM SUPPLY PRESSURE

System design and pump selection is critical when water heaters are connected to a low pressure water supply. Refer to the table below for minimum pressure requirements for Grundfos UPS series pumps. Minimum pressure requirements for TP series pumps depend on system characteristics and need to be calculated. Contact your pump supplier for details.

Pump	Model	Minimum Inlet Pressure Required (m) at Operating Temperature				
		75°C	80°C	85°C	90°C	95°C
UPS32-80N	280, 350, 430, 538, 658	0.5	0.5	0.5	3.0	5.0
UPS40-60/2B	768, 868, 972, 992	1.5	2.5	3.5	4.5	7.0
UPS50-120FB	1142, 1182, 1242, 1292, 1362, 1412, 1662, 1722, 1852, 1922, 2004, 2214, 2404, 2634	4.0	5.0	6.0	7.0	9.0
UPS80-120FB	2804, 3164, 3304, 3694, 3804, 4224	16.0	17.0	18.0	19.0	20.5

WATER SUPPLY AND RELIEF VALVE SETTINGS

Burner Type	On/Off		Modulating	
	Models	All	200–430	538–4224
Relief Valve Setting				
Potable Hot Water	kPa	850	850**	850**
Mechanical Heating	kPa	–	310	415
Expansion Control Valve (ECV*) Setting				
Potable Hot Water	kPa	700	700**	700**
Mechanical Heating	kPa	–	–	–
Maximum Supply Pressure without ECV* fitted				
Potable Hot Water	kPa	680	680**	680**
Mechanical Heating	kPa	–	240	330
with ECV* fitted				
Potable Hot Water	kPa	550	550**	550**
Mechanical Heating	kPa	–	–	–

RAYPAK MODEL NUMBERS

The following information should be supplied when ordering Raypak water heaters

B	0430	N	C	O	/	ID
Water	Approx	N = Natural Gas	Copper Heat	O = On/Off		ID = Indoor
Heater	Thermal Input [#]	P = Propane	Exchanger	M = Modulating		HWT = High Wind Top

Note: #last digit designates series type i.e. an 8, 2 or 4 series.

GAS PRESSURE		200-430	538-4224
Natural	Minimum	kPa 1.13	1.13
	Test Point	kPa 0.77	0.92
	Maximum	kPa 3.50	4.00
ULPG	Minimum	kPa 2.75	-
	Test Point	kPa 2.75	-
	Maximum	kPa 3.50	-

THERMOSTAT SETTINGS

Modulating	Maximum	°C 95
	Factory set	°C 78
	Minimum	°C 44
On/Off	Maximum	°C 80
	Factory set	°C 50
	Minimum	°C 44

*CLEARANCES COMBUSTIBLES (mm)

Model	Back	Front	Left	Right	Ceiling
200 to 430	500	750	600	500	1,200
538 to 1922	600	750	600	600	1,200
2004 to 4224	600	1,200	600	600	1,200

*CLEARANCES NON COMBUSTIBLES (mm)

Model	Back	Front	Left	Right	Ceiling
200 to 430	150	750	600	150	1,200
538 to 1922	150	750	600	600	1,200
2004 to 4224	300	1,200	600	600	1,200

^ Excludes flue terminal clearances. Refer to AS/NZS 5601.1.

* Expansion Control Valve is not supplied with the water heater.

** An 850kPa relief valve can be fitted to modulating water heaters used in potable hot water applications.

HEAVY DUTY ELECTRIC

The robust vitreous enamel hot water system for durability in a wider range of water quality environments.

The Rheem Heavy Duty Electric Products have been reliable and dependable for decades.

Their Service and Training Facilities are second to none.

Dale Craig,
Client Service Manager - Asset Services
CV SERVICES

CASE STUDY

PERTH STADIUM

Challenge

Opened in 2018, the Perth Stadium is a multi-purpose venue capable of hosting 60,000 fans for sporting and entertainment events. A stable and robust hot water solution that could meet peak demand was required.

Hot Water Solution

To accommodate such a large user requirement on hot water, Rheem installed 130 x Electric Heavy Duty 50L and 17 x Electric Heavy Duty 315L. Additionally, mechanical heating with Heat Exchanger and large SS Storage complements the system.



HEAVY DUTY ELECTRIC

FOR SMALL TO LARGE APPLICATIONS



DOUBLE-COATED ENAMEL

LARGER ANODE

UP TO 36 kW

HIGH PRESSURE 

Designed for domestic and to a large scale of commercial applications, and to suit most water chemistries.



Quality

One of the reasons of the reputation of Rheem with the experts is high quality. Take the Rheem storage cylinder: it's made from a special grade of steel and lined with a double coat of vitreous enamel, which is better suited to a wider variety of water conditions while larger anodes provide greater protection.

Never lose pressure

HDE uses true multipoint operation through large 32mm connections with no exchange coils to restrict pressure or flow, and it can be used with low pressure systems if needed.

More key features

- Suitable for either indoor or outdoor installation
- Up to 36kW (in one water heater) providing plenty of hot water
- Trade adjustable thermostats suitable for sanitizing
- A manifold of 8 x A616315 Rheem commercial electric water heaters can deliver up to 7,480 litres of hot water in the first hour

Heavy Duty Electric warranty: 5 years on cylinder, 1 year on parts & labour

TECHNICAL ELECTRIC PERFORMANCE DETAILS

Heating Elements		3 x 3.6 kW	3 x 4.8 kW	3 x 6.0 kW	6 x 3.6 kW	6 x 4.8 kW	6 x 6.0 kW
Total Input	kW	10.8	14.4	18.0	21.6	28.8	36.0
Current (per phase)	Amps	15	20	25	30	40	50
Litres Recovery Per Hour at Rise of	20°C	460	620	770	930	1240	1550
	30°C	310	410	520	620	830	1030
	40°C	230	310	390	460	620	770
	50°C	190	250	310	370	500	620
	60°C	150	210	260	310	410	520
	65°C	140	190	240	290	380	480
	70°C	130	180	220	270	350	440
75°C	120	170	210	250	330	410	

Note: Figures rounded to the nearest 10 litres.

TECHNICAL DATA

DIMENSIONS AND TECHNICAL DATA TABLE INDOOR/OUTDOOR MODELS

Model		A613 050	A613 315	A616 315
Storage Capacity	Litres	60	325	325
Delivery Rating	Litres	50	315	315
Dimensions	A	mm	675	1640
	B	mm	436	638
	C	mm	476	678
	D	mm	405	1294
	E	mm	90	128
	F	mm	80	130
	H	Degrees	30°	32°
J	Degrees	90°	90°	90°
Weight – Empty	kg	34	96	98
Inlet/Outlet Connections (BSPF)		RP1¼	RP1¼	RP1¼
T&PR Valve Connection (BSPF)		RP¾	RP¾	RP¾
T&PR Valve Setting	kPa	1000	1000	1000
Expansion Control Valve (ECV)* Setting	kPa	850	850	850
Max. Water Supply Pressure				
without ECV* fitted	kPa	800	800	800
with ECV* fitted	kPa	680	680	680
Factory Thermostat Setting	°C	70	70	70
Min. Thermostat Setting	°C	60	60	60
Manifold – Min. Centre to Centre	mm	685	890	890
Electrical Connection				
240V		single phase [^]	single phase [^]	
415V		three phase	three phase	three phase
Heating Elements	kW	3 x 3.6	3 x 3.6	6 x 3.6
	or	3 x 4.8	3 x 4.8	6 x 4.8
	or	–	3 x 6.0	6 x 6.0

* Expansion control valve not supplied with the water heater.

[^] Before using this application please contact the Commercial Team at Rheem New Zealand Ltd

APPROXIMATE DAILY ENERGY CONSUMPTION

Daily Hot Water Usage @ 50°C Temp Rise (Litres)	Energy Content of Hot Water (kWh)	RHEEM COMMERCIAL ELECTRIC WATER HEATERS Approximate Energy Used Per Day (kWh)		
		A613 050	A613 315	A616 315
0	0.0	1.8	3.1	3.2
50	2.9	4.7	6.0	6.1
100	5.8	7.6	8.9	9.0
150	8.7	10.5	11.8	11.9
200	11.6	13.4	14.7	14.8
250	14.5	16.3	17.6	17.7
300	17.4	19.2	20.5	20.6
350	20.3	22.1	23.4	23.5
400	23.3	25.1	26.4	26.5
450	26.2	28.0	29.3	29.4
500	29.1	30.9	32.2	32.3
600	34.9	36.7	38.0	38.1
700	40.7	42.5	43.8	43.9
800	46.5	48.3	49.6	49.7
900	52.3	54.1	55.4	55.5
1000	58.1	59.9	61.2	61.3
1250	72.7	74.5	75.8	75.9
1500	87.2	89.0	90.3	90.4
1750	101.7	103.5	104.8	104.9
2000	116.3	118.1	119.4	119.5
2500	145.3	–	148.4	148.5
3000	174.4	–	–	177.6
3500	203.5	–	–	206.7
4000	232.6	–	–	235.8
5000	290.7	–	–	293.9

Side view

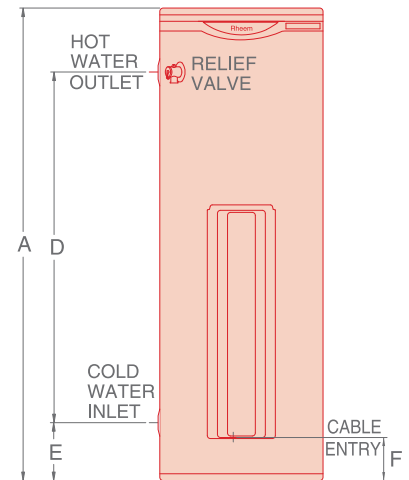

Plan view

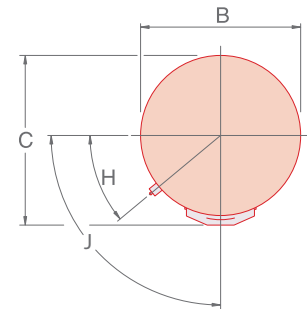

PERFORMANCE DATA

Model	No. of Units in Parallel	Initial Delivery (Litres)	Heating Elements (kW)	Total Kilowatts	Available Litres of Hot Water at 50°C Temperature Rise Over Peak Period					
					1 Hour	2 Hours	3 Hours	4 Hours	6 Hours	8 Hours
A613 050	1	50	3 x 3.6	10.8	240	420	610	790	1160	1540
			3 x 4.8	14.4	300	550	790	1040	1540	2030
A613 315	1	315	3 x 3.6	10.8	500	690	870	1060	1430	1800
			3 x 4.8	14.4	560	810	1060	1310	1800	2300
			3 x 6.0	18.0	620	930	1240	1550	2170	2790
	2	630	3 x 3.6	21.6	1000	1370	1740	2120	2860	3600
			3 x 4.8	28.8	1130	1620	2120	2610	3600	4590
			3 x 6.0	36.0	1250	1870	2490	3110	4350	5580
	3	945	3 x 3.6	32.4	1500	2060	2620	3170	4290	5400
			3 x 4.8	43.2	1690	2430	3170	3920	5400	6890
			3 x 6.0	54.0	1870	2800	3730	4660	6520	8380
A616 315	1	315	6 x 3.6	21.6	690	1060	1430	1800	2540	3290
			6 x 4.8	28.8	810	1310	1800	2300	3290	4280
			6 x 6.0	36.0	930	1550	2170	2790	4030	5270
	2	630	6 x 3.6	43.2	1370	2120	2860	3600	5090	6570
			6 x 4.8	57.6	1620	2610	3600	4590	6570	8560
			6 x 6.0	72.0	1870	3110	4350	5580	8060	10540
	3	945	6 x 3.6	64.8	2060	3170	4290	5400	7630	9860
			6 x 4.8	86.4	2430	3920	5400	6890	9860	12830
			6 x 6.0	108.0	2800	4660	6520	8380	12090	15810
	4	1260	6 x 3.6	86.4	2750	4230	5720	7200	10180	13150
			6 x 4.8	115.2	3240	5220	7200	9190	13150	17110
			6 x 6.0	144.0	3740	6210	8690	11170	16120	21070
5	1575	6 x 3.6	108.0	3430	5290	7150	9010	12720	16440	
		6 x 4.8	144.0	4050	6530	9010	11480	16440	21390	
		6 x 6.0	180.0	4670	7770	10860	13960	20150	26340	
6	1890	6 x 3.6	129.6	4120	6350	8580	10810	15260	19720	
		6 x 4.8	172.8	4860	7830	10810	13780	19720	25670	
		6 x 6.0	216.0	5610	9320	13040	16750	24180	31610	

Model	No. of Units in Parallel	Initial Delivery (Litres)	Heating Elements (kW)	Total Kilowatts	Available Litres of Hot Water at 65°C Temperature Rise Over Peak Period					
					1 Hour	2 Hours	3 Hours	4 Hours	6 Hours	8 Hours
A613 050	1	50	3 x 3.6	10.8	190	340	480	620	910	1190
			3 x 4.8	14.4	240	430	620	810	1190	1570
A613 315	1	315	3 x 3.6	10.8	460	600	740	890	1170	1460
			3 x 4.8	14.4	510	700	890	1080	1460	1840
			3 x 6.0	18.0	550	790	1030	1270	1740	2220
	2	630	3 x 3.6	21.6	920	1200	1490	1770	2340	2920
			3 x 4.8	28.8	1010	1390	1770	2150	2920	3680
			3 x 6.0	36.0	1110	1580	2060	2540	3490	4440
	3	945	3 x 3.6	32.4	1370	1800	2230	2660	3520	4370
			3 x 4.8	43.2	1520	2090	2660	3230	4370	5520
			3 x 6.0	54.0	1660	2370	3090	3800	5230	6660
A616 315	1	315	6 x 3.6	21.6	600	890	1170	1460	2030	2600
			6 x 4.8	28.8	700	1080	1460	1840	2600	3360
			6 x 6.0	36.0	790	1270	1740	2220	3170	4130
	2	630	6 x 3.6	43.2	1200	1770	2340	2920	4060	5200
			6 x 4.8	57.6	1390	2150	2920	3680	5200	6730
			6 x 6.0	72.0	1580	2540	3490	4440	6350	8250
	3	945	6 x 3.6	64.8	1800	2660	3520	4370	6090	7800
			6 x 4.8	86.4	2090	3230	4370	5520	7800	10090
			6 x 6.0	108.0	2370	3800	5230	6660	9520	12380

Note: Figures rounded to the nearest 10 litres.

COMMERCIAL ELECTRIC HEATING UNIT

FOR LARGE SCALE APPLICATIONS
USING RT STORAGE TANKS*



**HIGHLY
DURABLE** 

9 SIZES
15-180 kW

UP TO **3,000 L/hr**
RECOVERY

The long-life large-scale electric water heating unit.

Highly durable

Element sheath made of incoloy 800 and low watt heating density of less than 0.6W/cm². Add to this an IP65-rated 304 grade stainless steel electrical enclosure, 316L stainless steel flange plate with EPDM gasket and sun shield. Manufactured with long-life components, like the AC3-rated contactor, providing over 1,000,000 cycles.

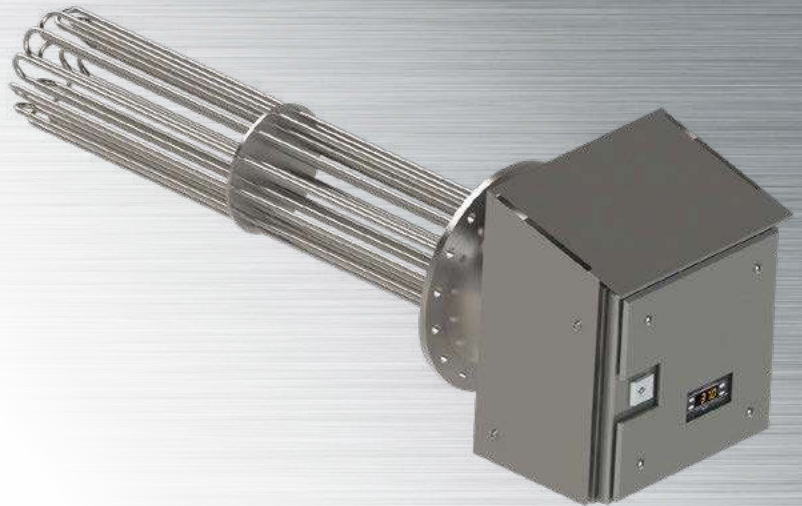

High capacity

Available in nine sizes from 15kW up to 180kW, providing a huge heating capacity up to 3000L/hr recovery raised 50°C, and tank capacity ranges from nominal 1000 to 5000 litres.

Fuel redundancy

Can be interlocked with other fuel source water heaters, for example timer or thermostatically controlled, to maximise the solar contribution factor (SCF) or ensure hot water supply in low ambient conditions with heat pumps.

More key features

- Thermostat has visual temperature display and can be user-set up to 83°C.
- When coupled with the Rheem RT Series of large capacity stainless steel or carbon steel storage tanks, the heating unit can be placed in the upper or lower tank flange, with the upper flange providing solar or heat pump boost options or the lower flange being used as a standalone electric water heater.

*See RT Storage Tanks on Page 84

Commercial Electric Heating Unit warranty: 2 years on heating element,
1 year on parts & labour

TECHNICAL DATA

Dimensions and Technical Data Table

Model		050350	050351	050352	050353	050354	050355	050356	050357	050358
Nominal Rating	kW	15	30	45	60	75	100	125	150	180
Electrical Rating		380 - 415 V AC 50/60Hz Star Connected					380 - 415 V AC 50/60Hz Delta Connected			
Recovery Rate (50°C Rise)	L/hr	258	516	774	1032	1290	1720	2150	2580	3096
Current per Phase	Amps	21	42	63	83	104	139	174	208	250
Factory Setting	°C	70	70	70	70	70	70	70	70	70
Max. Thermostat Setting	°C	90	90	90	90	90	90	90	90	90
ECO Setting	°C	95	95	95	95	95	95	95	95	95
Cabinet Width (A)	mm	300	300	300	300	400	400	600	600	600
Cabinet Height (B)	mm	300	300	300	300	400	400	400	400	400
Cabinet Depth (C)	mm	218	218	218	218	248	248	322	322	322
Exposed Length (D)	mm	316	316	316	316	346	346	420	420	420
Immersed Length (L)	mm	750	750	750	750 <td 750	750	1250	1250	1500	1500
Weight (packaged)	kg	47.5	48.2	49	49.8	50.7	53.6	55	56.6	58.2
Suitable Series Tank	litres	RT1000 – 5000	1000 – 5000	1000 – 5000	1000 – 5000	1000 – 5000	3000 – 5000	3000 – 5000	5000	5000

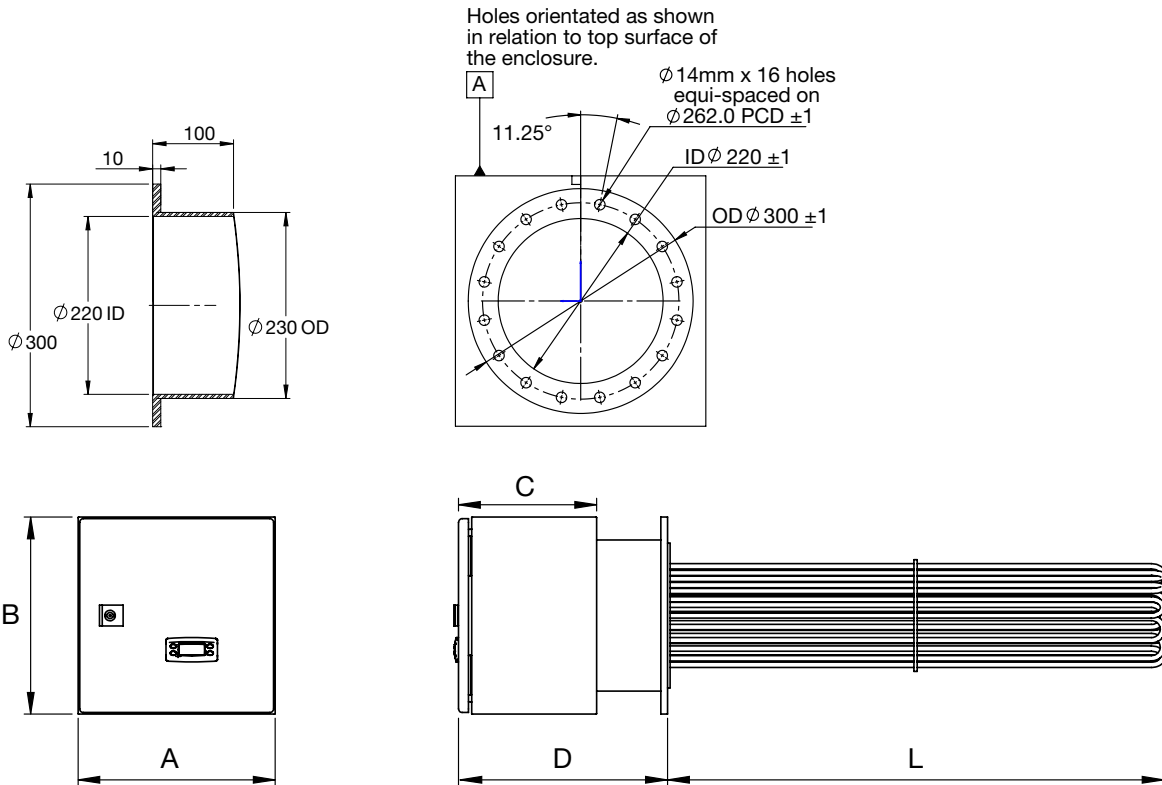

COMMERCIAL HEAT PUMP

Heat water via depleting free energy from the air, by using our Air to Water models. Or heat water, via using waste heat from a chiller, after installing our Water to Water models.

We needed to replace 24 individual water heaters on our hotel roof. These were being boosted by a backup gas boiler. Since switching to Rheem Commercial Heat Pumps, we have seen our energy bill reduced drastically and have not had to use our gas boiler since.

Mark, DoubleTree by Hilton Hotel, Cairns

CASE STUDY

AUSTRALIAN UNITY

PARRAMATTA, NSW

This modern office building, comprising 14 levels of office space in Parramatta, needed an End of Trip Facility.

Hot Water Requirements

With the consultant's project requirements calling for a high-efficiency hot water plant capable of accommodating 10 showers and a 2000L load requirement over a two-hour peak, Rheem Commercial sized and proposed a ducted commercial air to water heat pump. Configured to vent cool discharge air into the car park entrance via a sheet metal duct, the system's flexibility was also a major advantage when it came to accommodating the limited space available for the hot water plant.

Solution

In order to provide a hot water boost in situations, where higher than expected peak loads or low overnight temperatures preclude heat pump hot water recovery, a 15kW heating element was installed in the top third of the 2000L Rheem Stainless Steel storage tank.



RHEEM COMMERCIAL HEAT PUMP

Rheem Commercial (the largest supplier of commercial water heaters in Australasia) is now introducing two groups of heat pumps with two different technologies by collecting free heat energy from air and waste heat from the building chilling circuit.



Rheem offers an expanded true commercial grade, high thermal efficiency, WaterMark-certified heat pump range – in both air to water and water to water technologies.

These high efficiency models offer:

- Reduced running costs and reduced CO2 emissions for building owners
- High quality components for durability
- Suitability to most of New Zealand's climate
- Rheem iQ control provides on-board diagnostics, system configuration and optional BMS connectivity
- Two model sizes in each range that broaden your redundancy and shrink your plant footprint

Manufactured by Rheem in Australia, the Commercial Heat Pump range in New Zealand is supported by a nationwide service centre network along with New Zealand technical support.



Warranty: 2 years on heat pump sealed system,
1 year on parts & labour

AIR TO WATER HEAT PUMP

FOR WHERE ENERGY EFFICIENCY IS ESSENTIAL



HOT WATER TO

65°C

SAVE UP TO

75% ENERGY

FLEXIBLE USES CAR PARK AIR



65°C hot water in a super-efficient, super-compact package.



Highly efficient

Uses up to 75% less of the operating cost of an electric water heater. Delivers hot water up to 65°C, with a system Coefficient of Performance (COP) of up to 4.01. This makes it substantially cheaper to run than electric, natural gas or ULPG. Highly efficient option for fuel redundancy. Heat pumps can also be used as a preheat to other boost fuel types.

Green points

Adds to the green points from end-of-trip facilities. The heat pump is designed to draw its air from and discharge within basement car parks without flueing, unlike gas systems.

Multiple installation options

Designed for both vertical or horizontal discharge options, with a discharge fan option available in both ducted and non-ducted versions. Horizontal discharge models can also be stacked two high to reduce plant footprint (suffix 'S').

Suits most of New Zealand's climate*

Automatic defrost allows continued performance in low ambient temperature conditions by diverting a portion of the hot refrigerant to the evaporator coil to melt any ice which may form. In addition, the evaporator is dipped to provide extra protection in corrosive atmospheres, and the unit has been tested in ambient conditions as high as 40°C.

* Enquire at Rheem New Zealand Ltd for very cold climates

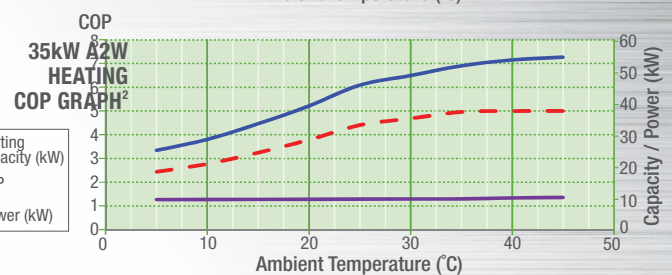
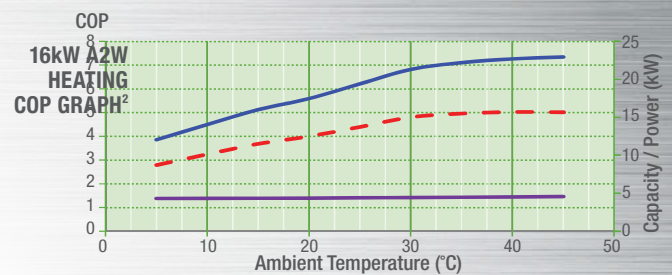

Typical installation

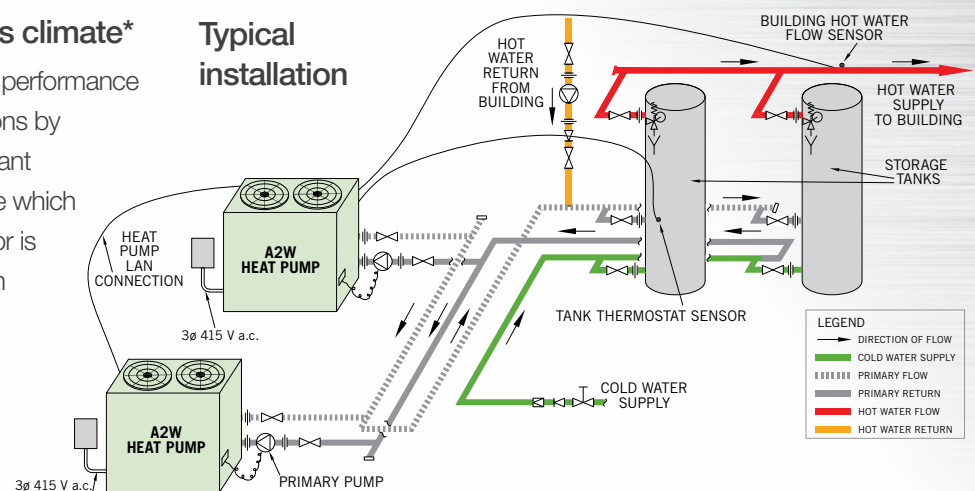

TECHNICAL DATA

AIR TO WATER 16kW MODEL

16kW AIR TO WATER – ALL HORIZONTAL DISCHARGE MODELS

953016H0 – Non Ducted 953016HS – Non Ducted stackable
 952016H0 – Ducted 952016HS – Ducted stackable

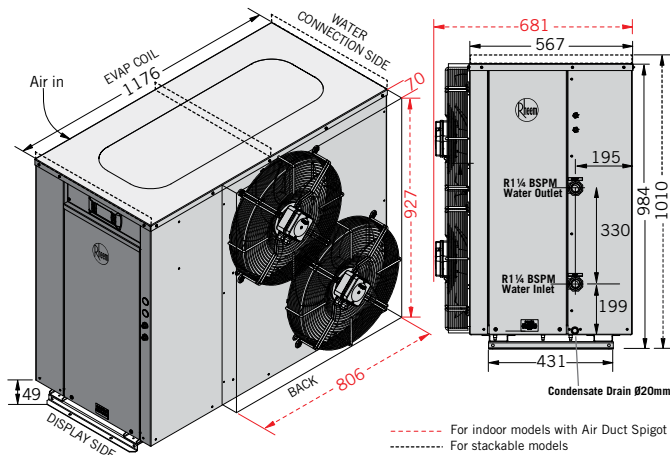

16kW AIR TO WATER – ALL VERTICAL DISCHARGE MODELS

95301600 – Non Ducted 95201600 – Ducted

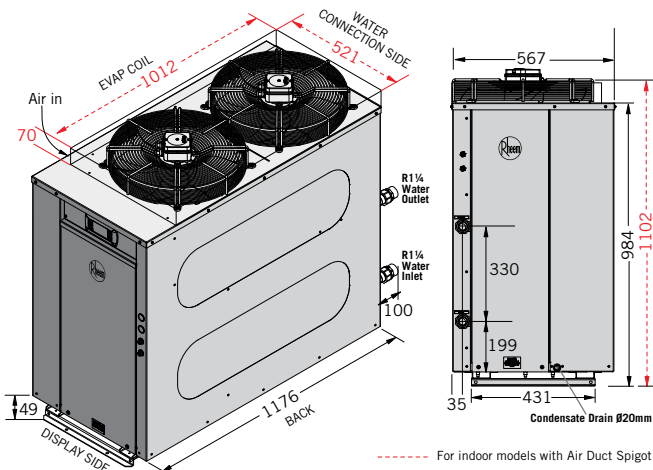

RECOVERY								
Ambient Temperature °C	5	10	15	20	25	30	35	40
Output (kW)	12	14.5	16.4	17.46	19.5	21.7	22.5	23
Recovery – Litres per hour								
20°C rise	516	624	705	751	839	933	968	989
25°C rise	413	499	564	601	671	746	774	791
30°C rise	344	416	470	501	559	622	645	659
35°C rise	295	356	403	429	479	533	553	565
40°C rise	258	312	353	375	419	467	484	495
45°C rise	229	277	313	334	373	415	430	440
50°C rise	206	249	282	300	335	373	387	396
55°C rise	188	227	256	273	305	339	352	360

PRODUCT DATA		Ducted Exhaust	Non Ducted Exhaust
Heating Capacity*	kW	17.46	17.46
Power Input*	kW	4.01	4.01
COP*		4.0	4.0
Recovery @ 50°C Rise*	L/hr		300
Operating Range (ambient)	°C		5-45
Outlet Temperature	°C		65
Refrigerant			R134a
TPR Valve Setting (VE/SS)	kPa		1000/850
ECV Setting (VE/SS)**	kPa		850 /700
Maximum Water Pressure Supply			
Without ECV (VE/SS)**	kPa		800/680
With ECV (VE/SS)**	kPa		650/550
Electrical Connection		3Phase/415V/50Hz	
Max Current per Phase (running, incl pump)	Amps	17.06	15.22
Minimum Circuit Size (per phase)	Amps		20
Air Flow (at maximum static pressure)	L/s		1600
Maximum Static Pressure	Pa	80	20
Minimum Ventilation per inlet and outlet	m ²		1
Minimum room volume for indoor installation [^]	m ³		7.5
Sound Pressure Level	dBA		59@3m
Approx Weight Empty	kg		120
Approx Weight Full	kg		125
Storage per Heat Pump	L		400-4,000
Clearances			
Evaporator Coil Side	mm		500
Back (vertical discharge models)	mm		Nil
Back (horizontal discharge models)	mm		1200
Display Side	mm		850
Water Connections Side	mm		500
Top (vertical discharge models)	mm		1200
Top (horizontal discharge option)	mm		Clearance above unit required for service personnel to stand

HEAT PUMP SIZING CHART				
Number of Heat Pumps in Parallel	1	2	3	4
Primary Pump	Grundfos CM 3-2			
Branch Size ID	40			
Header Size ID	40	50	65	80

Note: Header pipe sizing is based on a total length of 40m of primary flow and return piping and 20 bends, excluding equal-flow manifolds on storage tanks and heat pumps @ 1.2m/sec velocity. One pump per Heat Pump.

ACCESSORIES			
Storage Tank	Pump	BMS Card	LAN Cable
410L (VE) A610 430		17520 BACnet TCP/IP	
1000L to 5000L (SS)	CM 3-2	17521 BACnet MS/TP	17495
RT Series		17522 Modbus RS485	

* 20°C ambient/60%RH. 39°C water in / 45°C water out.

**ECV not supplied with water heater

[^] To comply with AS1677.2, the minimum room size permissible is 7.5m³ for 16kW and 17.73m³ for 35kW per heat pump for indoor installation. A larger room size is recommended for efficient heat pump operation.

TECHNICAL DATA

AIR TO WATER 35kW MODEL

35kW AIR TO WATER – ALL HORIZONTAL DISCHARGE MODELS

953035H0 – Non Ducted 953035HS – Non Ducted stackable
 952035H0 – Ducted 952035HS – Ducted stackable

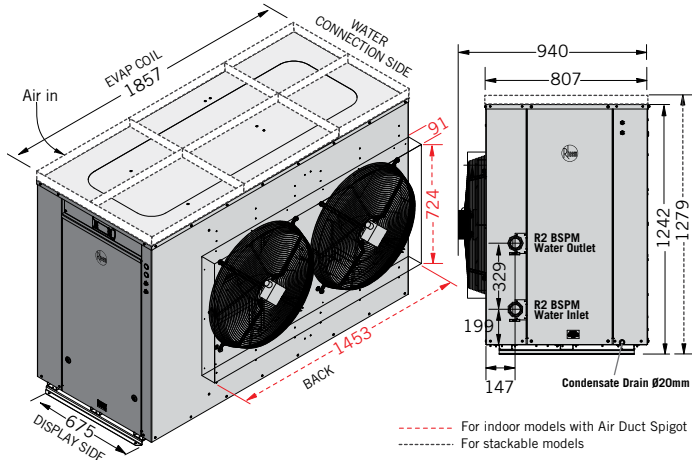

35kW AIR TO WATER – ALL VERTICAL DISCHARGE MODELS

95303500 – Non Ducted 95203500 – Ducted

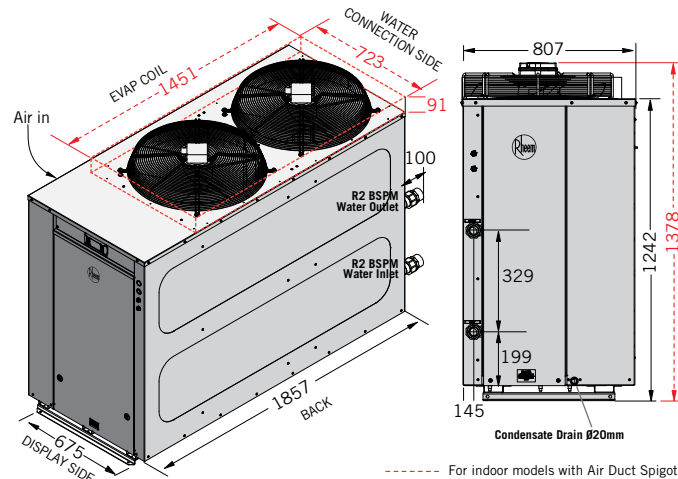

RECOVERY								
Ambient Temperature °C	5	10	15	20	25	30	35	40
Output (kW)	25.5	29	34.6	39.55	46.6	49.9	53	54.1
Recovery – Litres per hour								
20°C rise	1097	1247	1488	1701	2004	2146	2279	2326
25°C rise	877	998	1190	1361	1603	1717	1823	1861
30°C rise	731	831	992	1134	1336	1430	1519	1551
35°C rise	627	713	850	972	1145	1226	1302	1329
40°C rise	548	624	744	850	1002	1073	1140	1163
45°C rise	487	554	661	756	891	954	1013	1034
50°C rise	439	499	595	680	802	858	912	931
55°C rise	399	453	541	618	729	780	829	846

PRODUCT DATA		Ducted Exhaust	Non Ducted Exhaust
Heating Capacity*	kW	39.55	39.55
Power Input*	kW	10.25	10.25
COP*		3.9	3.9
Recovery @ 50°C Rise*	L/hr	680	680
Operating Range (ambient)	°C	5-45	5-45
Outlet Temperature	°C	65	65
Refrigerant		R134a	R134a
TPR Valve Setting (VE/SS)	kPa	1000/850	1000/850
ECV Valve Setting (VE/SS)**	kPa	850/700	850/700
Maximum Water Pressure Supply			
Without ECV (VE/SS)**	kPa	800/680	800/680
With ECV (VE/SS)**	kPa	650/550	650/550
Electrical Connection		380 - 415 Volts / 3 Phase / 50 Hz	
Max Current per Phase (running, incl pump)	Amps	34.9	32.34
Minimum Circuit Size (per phase)	Amps	40	
Air Flow (at maximum static pressure)	L/s	5830	5270
Maximum Static Pressure	Pa	100	20
Minimum Ventilation per inlet and outlet	m ²	1.93	
Minimum room volume for indoor installation [†]	m ³	17.73	
Sound Pressure Level	dBA	69@3m	
Approx Weight Empty	kg	300	
Approx Weight Full	kg	310	
Storage per Heat Pump	L	400-8,000	
Clearances			
Evaporator Coil Side	mm	1000	
Back (vertical discharge models)	mm	Nil	
Back (horizontal discharge models)	mm	2000	
Display Side	mm	850	
Water Connections Side	mm	600	
Top (vertical discharge models)	mm	2000	
Top (horizontal discharge option)	mm	Clearance above unit required for service personnel to stand	

PUMP & PIPE SIZING CHART				
Number of Heat Pumps in Parallel	1	2	3	4
Primary Pump	Grundfos CM 10-1			
Branch Size ID	50			
Header Size ID	50	80	100	100

Note: Header pipe sizing is based on a total length of 40m of primary flow and return piping and 20 bends, excluding equa-flow manifolds on storage tanks and heat pumps @ 2.2m/sec velocity. One pump per Heat Pump.

ACCESSORIES			
Storage Tank	Pump	BMS Card	LAN Cable
410L (VE) A610 430	CM 10-1	17520- BACnet TCP/IP	17495
1000L to 5000L (SS)		17521- BACnet MS/TP	
RT Series		17522- Modbus RS485	

* 20°C ambient/60%RH. 39°C water in / 45°C water out.
 **ECV not supplied with water heater
[†] To comply with AS1677.2, the minimum room size permissible is 7.5m³ for 16kW and 17.73m³ for 35kW per heat pump for indoor installation.
 A larger room size is recommended for efficient heat pump operation.

WATER TO WATER HEAT PUMP

FOR WHERE ENERGY EFFICIENCY IS ESSENTIAL



REDUCED CHILLING LOAD



COMPACT

UP TO 7.0 COP EFFICIENCY*

The Rheem Water to Water (W2W) range includes units using R134a for hot water heating up to 65°C, with a minimum entering water temperature on the building chiller loop of 12°C, giving a return water temperature of 7°C. The units are compact and suitable for indoor or outdoor installation.



Efficiency

The ability of these units to provide a dual efficiency sees combined COPs of up to 7.05. The efficiency in hot water production is up to 4.05 and this leads to substantial savings in energy use and heating cost. The savings are magnified where the cooling by-product lessens a building's chilling load. COP in cooling are up to 3.05.

Return on investment

High COP of this product results in a very favourable return on investment, making the W2W HP a sound environmental and financial investment compared to gas and electric heating systems.

More key features

- Water Mark certified 316L stainless steel, double-wall brazed plate heat exchanger on domestic hot water side
- Multiple safeties including low temperature freeze protection and flow switch on the chilled water side
- Full commercial construction with marine grade aluminium case

Typical installation

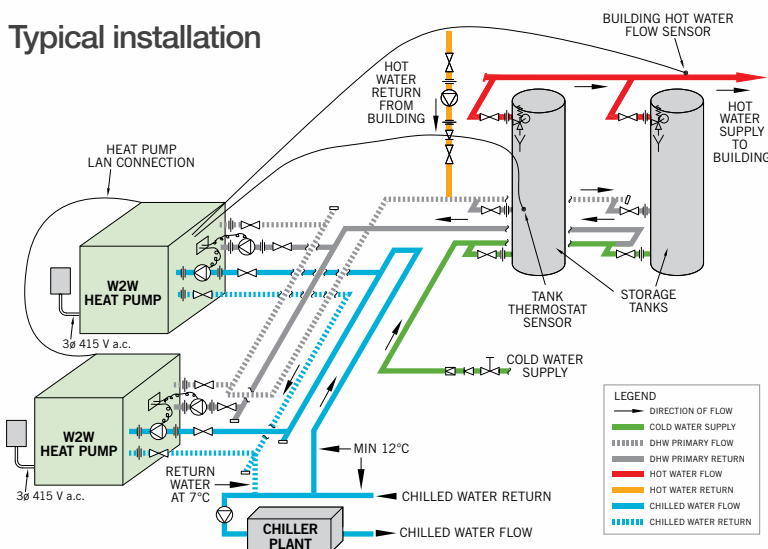

15kW W2W HEATING COP GRAPH

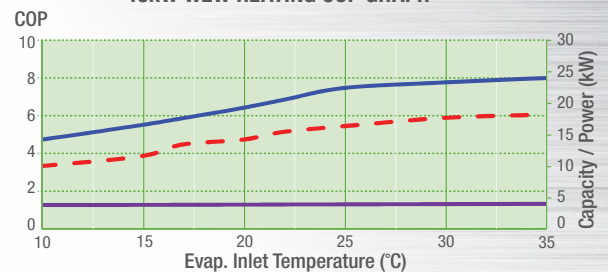

35kW W2W HEATING COP GRAPH

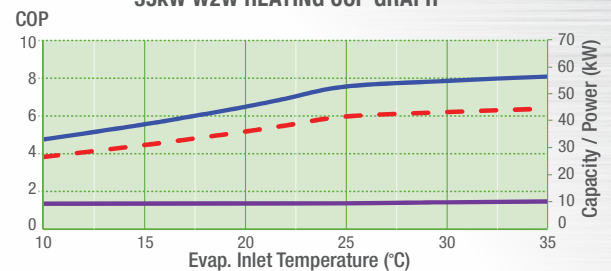

— Heating Capacity (kW) - - - COP — Power (kW)

TECHNICAL DATA

WATER TO WATER 15kW & 35kW MODEL

15kW MODEL

95401500 - non-stackable 9540150S - stackable

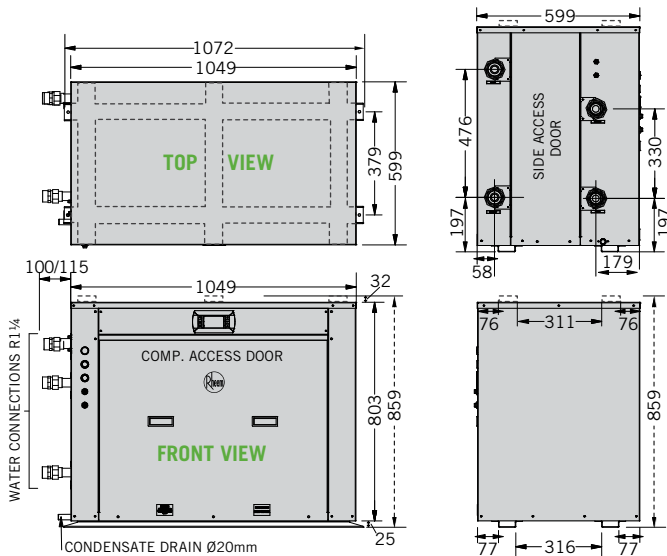

35kW MODEL

95403500 - non-stackable 9540350S - stackable

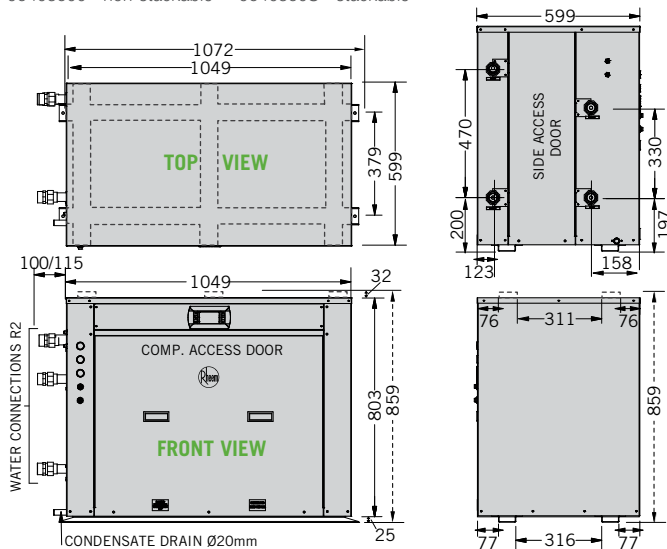

MODEL	15kW	35kW
Nominal Heating Capacity [^]	15kW	34.75kW
Nominal Cooling Capacity [^]	11.3kW	25.9kW
Power Input kW [^]	3.7kW	8.8kW
Coefficient of Performance (Heating) [^]	4	4
Coefficient of Performance (Cooling) [^]	3	3
Maximum DHW Temperature	65 °C	
Refrigerant	R134a	
Hot Water Side		
TPR Valve Setting (VE/SS)	1000/850 kPa	
ECV Setting (VE/SS)*	850/700 kPa	
Maximum Water Supply Pressure		
- Without ECV (VE/SS)*	800/680 kPa	
- With ECV (VE/SS)*	680/550 kPa	
Hot Water Side Flow Rate	1.1L/s	2.2L/s
Heat Exchanger Heating Design	316L Stainless steel – Double wall brazed plate	
Design Heating Temperature Difference	6°K	
Design Pressure Drop	40kPa	
Cold Water Side		
Maximum Water Supply Pressure	2450kPa	
Cold Water Side Flow Rate	1.1L/s	1.85L/s
Heat Exchanger Cooling Design	316L Stainless steel – Single wall brazed plate	
Design Cooling Temperature Difference	5 °K	
Design Pressure Drop	40kPa	
Minimum room volume for indoor installation	5.6m ³	15.34m ³
Electrical Connection	3 Phase / 415V / 50Hz	
Max Current per Phase (running, incl pumps)	13.96	29.94
Minimum Circuit Size (per phase)	20A	40
Sound Pressure Level	59dBa @ 3m	
Approx Weight Empty	100kg	120kg
Approx Weight Full	105kg	125kg
Storage per Heat Pump	400L to 4000L	400L to 8000L
Clearances		
Front	850mm	
Back	Nil mm	
Water Connections Side	850 mm	
RHS Side	Nil mm	
Top (clearance above unit required for service personnel to stand)	0 mm	

* ECV not supplied with water heater

[^] Rating Conditions: Heating 39°C Water in, 45°C water out, 51°C SCT, Cooling 12°C water in, 7°C water outlet, 2°C SST.

ACCESSORIES

Storage Tank	Pump	BMS Card	LAN Cable
410L (VE) A610 430	2 x CM 3-2 (16kW)	17520- BACnet TCP/IP	17495
1000L to 5000L (SS)	2 x CM 10-1 (35kW)	17521- BACnet MS/TP	
RT Series		17522- Modbus RS485	

PUMP & PIPE SIZING CHART

	15kW				35kW			
	HOT SIDE				HOT SIDE			
No. of Heat Pumps in Parallel	1	2	3	4	1	2	3	4
Pump	Grundfos CM 3-2				Grundfos CM10-1			
Branch Size (mm)	40				50			
Header Size (mm)	40	50	65	80	50	80	100	100
	COLD SIDE				COLD SIDE			
	HOT SIDE				HOT SIDE			
No. of Heat Pumps in Parallel	1	2	3	4	1	2	3	4
Pump	Grundfos CM 3-2				Grundfos CM10-1			
Branch Size (mm)	40				50			
Header Size (mm)	40	50	65	80	50	80	100	100

RECOVERY

Model	95401500			95403500		
Evaporator Inlet Temperature °C	12	20	35	12	20	35
Output (kW)	15	19	24	34.75	45.9	55.9
Recovery - Litres per hour						
20°C rise	645	817	1032	1494	1974	2404
25°C rise	516	654	826	1195	1579	1923
30°C rise	430	545	688	996	1316	1602
35°C rise	369	467	590	854	1128	1374
40°C rise	323	409	516	747	987	1202
45°C rise	287	363	459	664	877	1068
50°C rise	258	327	413	598	789	961
55°C rise	235	297	375	543	718	874

HEAT EXCHANGER TECHNOLOGY

The versatile,
high pressure
hydraulic separator.

At Givaudan, we focus on maintaining the highest food health and safety standards possible. This necessitated a comprehensive upgrade to our existing hot water plant. Rheem met the challenge by providing a smart total solution incorporating their innovative Crossflow Heat Exchange delivery skid.

Wayne Parry,
Engineering Manager (Oceania)

CASE STUDY

Pullman Hotel

Adelaide, SA

Challenge

Pullman Hotel is Adelaide's newest 5-star hotel in the heart of the Central Business District, offering 308 rooms and suites.

Hot Water Solution

To ensure instant hot water for this multi-storey construction, with an incoming supply pressure of 850kPa, Rheem heat exchanger technology was installed in March 2018.

The system consists of 3 x Raypak water heaters providing mechanical heating feeding 3 x Rheem storage 340L as buffer, supplying 2 x Rheem Crossflow to meet the peak demand at high supply pressure.



RHEEM CROSSFLOW™

SUITED TO COMMERCIAL APPLICATIONS, PARTICULARLY MULTI-STOREY CONSTRUCTION

HIGH PRESSURE
1400 kPa

W
CERTIFIED

BMS 
CONNECTIVITY

W2W HEAT TRANSFER

SMALL

Tankless, high pressure, instant hot water.

Rooftop penthouse vs. rooftop plant

High working pressure of 1400kPa, the result of its hydraulic separator design, means Crossflow™ can be located in the basement of tall buildings - leaving rooftop space available for more profitable allocation.

More power for the space

Variable speed pumps accurately match the required energy load to deliver tankless, on-demand hot water with exceptional temperature control.

Crossflow uses 25% of the space of an equivalent storage-based system.

Low pressure loss

Crossflow exhibits exceptionally low pressure drop, so there's minimal impact on building design.

Built-in redundancy

Designed with dual-head pump and twin heat-exchangers that share the load, allowing isolation for maintenance, with no interruption to supply.

Highly efficient heat exchange

Can be used with all heating types: solar, heat pump, gas, electric - as well as waste heat.

BMS and SCADA capability

Pump offers data transfer and monitoring capabilities to BMS or SCADA systems by an add-on CIM module suitable for Modbus, Bacnet and Lonworks.

More key features

- Factory assembled and tested on a hot dip galvanized frame
- All fittings and pipe work are 316L stainless steel
- Can be used as a hydraulic separator for solar, Co-gen and PP-R systems
- Grundfos Go remote APP Bluetooth enabled

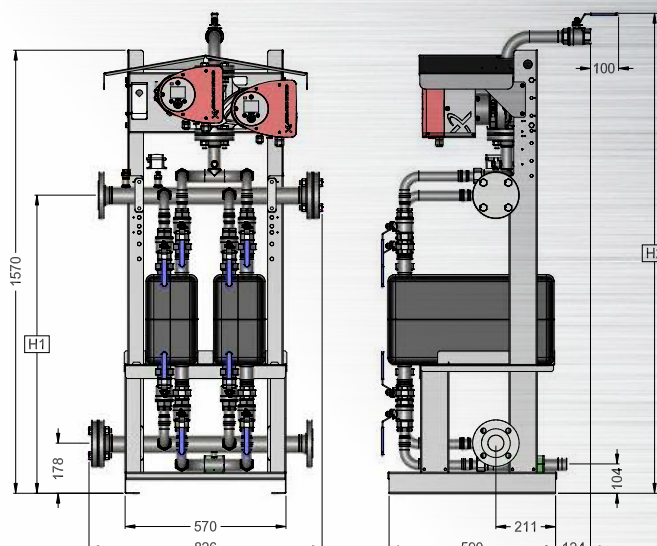

MODEL	DIM 'H1'	DIM 'H2'
RD200D701	877	1522
RD400D701	930	1575
RD600D701	993	1638
RD800D701	1056	1701

Rheem CrossFlow™ warranty: 1 year on heat exchanger, 1 year on parts & labour

TECHNICAL DATA

CROSS FLOW DIMENSIONS AND TECHNICAL DATA TABLE - RHEEM CROSSFLOW

Model		RD200	RD400	RD600	RD800	
Nominal Capacity	kW	200	400	600	800	
Parameters for Nominal Capacity Rating	Primary Side (non-potable)					
	Inlet Temp	°C	80	80	80	80
	Flow Rate	L/min	48	114	144	186
	Pressure Drop	kPa	24	47	36	36
	Secondary Side (potable)					
	Inlet/Outlet Temp	°C	15/65	15/65	15/65	15/65
	Flow Rate	L/min	57	115	172	223
	Pressure Drop	kPa	37	47	51	48
Dimensions	H x W x D	mm				1364 x 761 x 700
Weight	kg	130	138	147	156	
Pipe Connections Primary Circuit	BSPF		RP1¼			
Pipe Connections Secondary Circuit	50mm Flange Type E					
Max Operating Pressure Primary Circuit	kPa		1400*			
Max Operating Pressure Secondary Circuit	kPa		1400*			
Electrical Supply	230-240V 50/60Hz Hard Wired By Electrician					
Min Circuit Size	Amps		10			

*The maximum working pressure of each side of the system will be governed by the lowest operating appliance connected to it. The potable side (secondary side) water pressure must be higher than the non potable side (primary side) pressure.

Cross Flow Delivery Skid Secondary Side Flow Rate for Varying Primary Supply Temperatures and Secondary Side Temperature Rise

200kW						
Primary Temp	90	85	80	75	70	65
Output (kW)	270	215	200	190	160	100
Temp Rise	Secondary Side Flow Rate (L/min)					
65	60	47	44	42	35	
60	65	51	48	45	38	24
55	70	56	52	50	42	26
50	77	62	57	54	46	29
45	86	68	64	61	51	32
40	97	77	72	68	57	36
35	111	88	82	78	66	41

400kW						
Primary Temp	90	85	80	75	70	65
Output (kW)	500	450	400	365	300	200
Temp Rise	Secondary Side Flow Rate (L/min)					
65	110	99	88	80	66	
60	119	108	96	87	72	48
55	130	117	104	95	78	52
50	143	129	115	105	86	57
45	159	143	127	116	96	64
40	179	161	143	131	108	72
35	205	184	164	149	123	82

600kW						
Primary Temp	90	85	80	75	70	65
Output (kW)	740	680	600	535	450	300
Temp Rise	Secondary Side Flow Rate (L/min)					
65	163	150	132	118	99	
60	177	162	143	128	108	72
55	193	177	156	139	117	78
50	212	195	172	153	129	86
45	236	217	191	170	143	96
40	265	244	215	192	161	108
35	303	278	246	219	184	123

800kW						
Primary Temp	90	85	80	75	70	65
Output (kW)	940	870	800	695	580	400
Temp Rise	Secondary Side Flow Rate (L/min)					
65	207	192	176	153	128	
60	225	208	191	166	139	96
55	245	227	208	181	151	104
50	269	249	229	199	166	115
45	299	277	255	221	185	127
40	337	312	287	249	208	143
35	385	356	328	285	238	164

2 x 600kW						
Primary Temp	90	85	80	75	70	65
Output (kW)	1480	1360	1200	1070	900	600
Temp Rise	Secondary Side Flow Rate (L/min)					
65	326	300	265	236	198	
60	354	325	287	256	215	143
55	386	354	313	279	235	156
50	424	390	344	307	258	172
45	471	433	382	341	287	191
40	530	487	430	383	323	215
35	606	557	491	438	369	246

2 x 800kW						
Primary Temp	90	85	80	75	70	65
Output (kW)	1880	1740	1600	1390	1160	800
Temp Rise	Secondary Side Flow Rate (L/min)					
65	415	384	353	307	256	
60	449	416	382	332	277	191
55	490	453	417	362	302	208
50	539	499	459	398	333	229
45	599	554	510	443	369	255
40	674	624	573	498	416	287
35	770	713	655	569	475	328

Rheem Crossflow Maximum Output (T_{in}15°C-T_{in}65°C) vs. Primary supply temp

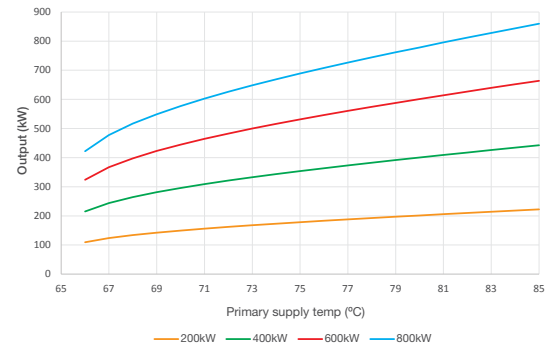

Rheem Crossflow Secondary Side Pressure Drop vs. Flow Rate

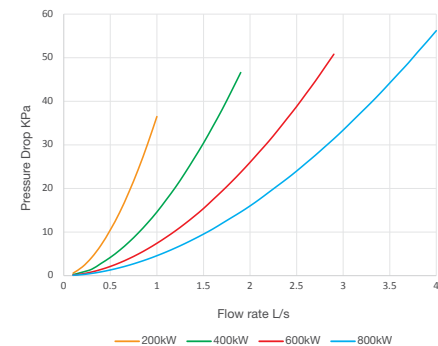

BRAZED PLATE HEAT EXCHANGER

SUITED TO CO-GEN AND TRI-GEN PLANTS, PROCESS HEATING, AND PRESSURE REDUCTION STATIONS

316 STAINLESS STEEL

W CERTIFIED

EASY TO MAINTAIN

W2W HEAT TRANSFER

MINIMUM PRESSURE DROP

One of the most versatile heat exchanger.

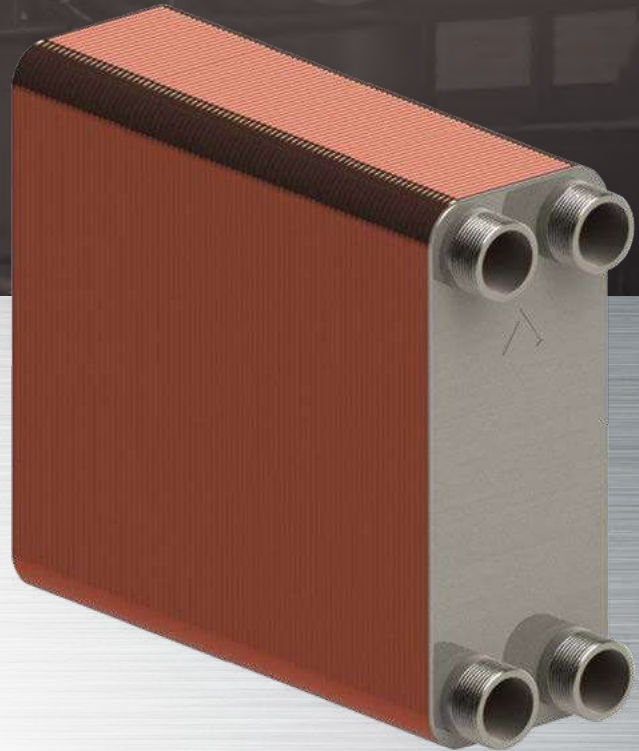

Ideal for custom engineering designs

316L stainless steel, single wall, brazed plate heat exchangers can be bolted together when more capacity is needed. Suits specialist applications, where high temperature and high pressure are needed.

Easy to inspect and maintain

Unlike other products that use internal coils, the external heat exchanger is easily isolated for repairs and maintenance.

Minimal pressure loss energy transfer

Parallel brazed plate construction means increased flow without the pressure drop, and high heat transfer efficiency in a compact package.

* For heat exchanger model, pipe sizes and primary pump on the potable side please refer to table on the next page.

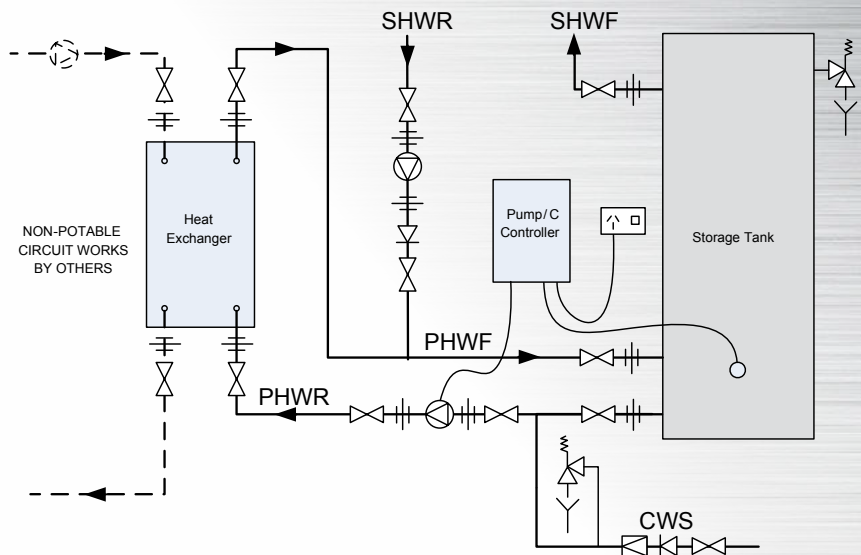

Legend

CWS: cold water supply
 PHWR: primary hot water return
 PHWF: primary hot water flow
 SHWS: secondary hot water supply
 SHWR: secondary hot water return

ECV
 TPR valve
 Tundish
 Isolation valve

Non return valve
 Pressure limiting valve
 Union
 Circulator or pump



Brazed Plate Heat Exchanger warranty:
 1 year on parts & labour

TECHNICAL DATA

HEAT EXCHANGER DIMENSIONS AND TECHNICAL DATA TABLE - RHEEM HEAT EXCHANGER								
Part Number				0191750	0191751	0191752	0191753	0191754
Nominal Rating			kW	50	100	150	200	250
Parameters for Nominal Rating	Non Potable Side	Inlet/Outlet Temp	°C	80/60	80/60	80/60	80/60	80/60
		Flow Rate	L/sec	0.61	1.22	1.83	2.44	3.05
		Pressure Drop	kPa	2.65	3.74	5.00	6.98	9.83
	Potable Side	Inlet/Outlet Temp	°C	45/65	45/65	45/65	45/65	45/65
		Flow Rate	L/sec	0.61	1.21	1.82	2.43	3.03
		Pressure Drop	kPa	2.39	3.59	4.91	6.91	9.79
Dimensions		Depth (D)	mm	104	160	221	277	333
Weight			kg	6	9	12	15	18
Operating Pressure			kPa	3000*				
Electrical Supply (Temperature Controller)		230-240V 50/60Hz Hard Wired By Electrician						

*The maximum working pressure of each side of the system will be governed by the lowest operating appliance connected to it. The potable side (secondary side) water pressure must be higher than the non potable side (primary side) pressure.

POTABLE SIDE PUMP AND PIPE SIZING

Heat Exchanger Model	Qty In Parallel	Output (kW)	Design Flow Rate	Minimum Potable Primary F & R Pipe Size (mm)	Pump Model / Speed Setting
0191750	1	50	0.61	32	UPS20-60N / 3
0191750	2	100	1.22	40	UPS32-80N / 3
0191751	1	100	1.21	40	UPS32-80N / 3
0191751	2	200	2.42	50	UPS40-60/2FB / 2
0191752	1	150	1.82	50	UPS32-80N / 3
0191752	2	300	3.64	65	UPS40-60/2FB / 3
0191753	1	200	2.43	50	UPS40-60/2FB / 3
0191753	2	400	4.86	80	UPS50-120FB / 1
0191754	1	250	3.03	65	UPS40-60/2FB / 3
0191754	2	500	6.06	80	UPS50-120FB / 3

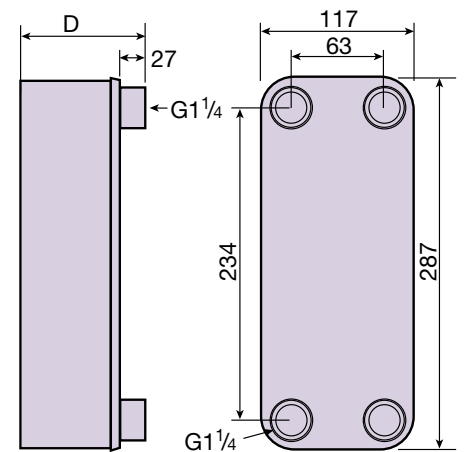

NOTE: Pipe sizing, pump selection and installation of the NON-POTABLE circuit is not covered by Rheem. Pipe and pump sizing is for potable water side only between the heat exchanger and storage tank/s and is based on 25m TOTAL pipe run and 20 x 90° bends @1.2m/s. If the piping is beyond this scope, please contact Rheem for assistance.

GUARDIAN HOT WATER

Maximum safety,
protection and operating
efficiency, in one
centralised system.

The Rheem Guardian system is the perfect warm water management system. Being a hotel, we must be on top of quality control and never bring any disruptions to our quality service to our guests.

We at Ovolo highly recommend the Rheem Guardian system for any business application, for ease of mind. We are confident in saying we provide the highest quality hot water for our guests on their special time away, no complaints and no service interruptions. Rheem are always on top of their game.

Tony Pacione, Maintenance Manager
Ovolo 1888 Darling Harbour

CASE STUDY

JETA GARDENS AGED CARE BETHANIA, QLD

Challenge

Completed in 2015, the \$13 million resort-style building accommodates 72 residents over three levels and required a safe, reliable and effective hot and warm water supply, with capability for disinfection from Legionella bacteria.

Hot Water Solution

Rheem devised a three-component solution consisting of a Guardian warm water system, solar pre-heat storage and a Heavy Duty gas-boost plant. Rheem Commercial also provided design guidance on the ideal position of the solar component, ensuring optimisation of the building's available north-facing roof space. Rheem provides six-monthly services, including water testing for Legionella, throughout the system.



GUARDIAN WARM WATER

WHERE CONTROLLED
WARM WATER IS NEEDED



LOW
OPERATING
COSTS



FAST
REPLACEMENT

SERVICED
WARM
WATER

Maximum safety, protection and operating efficiency in one centralised system.

High safety performance

Thermostatic mixing valve technology for accurate temperature control and ultraviolet disinfection, with no impact on pipework or water quality. Guardian features a tamper-proof design and UV fault detection, ensuring consistent performance and safety.

Lower operating costs

Centralised temperature monitoring and valve maintenance mean reduced capital and operating costs in facilities with more than 22 beds, compared with equivalent TMV systems.

Fast replacement

With more Rheem Guardian units in Australia than any other centralised system, they're easy to replace in existing installations. Plus, when regulations make tempering mandatory when replacing a water heater, Guardian can be added without individually tempering a whole building.

Multiple installation and design options

Available in three sizes, easily manifolded for increased capacity, and able to be installed both inside and outside. The primary heating plant can also be used to supply both tempered and non-tempered water.

Service

Rheem recommends yearly service maintenance that is carried out by a qualified professional.



Typical Installation Rheem Warm & Hot Water

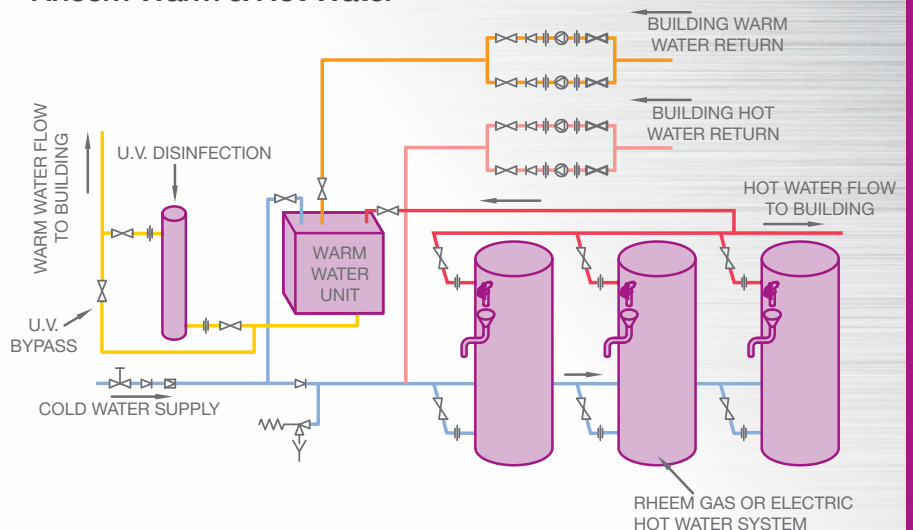

Guardian Warm Water warranty: 2 years on commercial cartridge

TECHNICAL DATA

WARM WATER

Model		940 08001	940 16001	940 24001
Nominated Flow Rate [^]	L/min	80	160	240
Max. Water Supply Pressure – Static/Dynamic	kPa	1000/800	1000/800	1000/800
Min. Water Supply Pressure	kPa	500	500	500
Thermostatic Control Range	°C	25 – 60	25 – 60	25 – 60
Max. Hot Water Supply Temp (Temporary)	°C	70	70	70
Max. Outlet Temperature (Sanitising)*	°C	70	70	70
Min. Temp Differential Between Cold Supply and Outlet (Flow Conditions)	°C	15	15	15
Hot Supply and Outlet (Flow Conditions)	°C	15	15	15
Recommended Minimum Recirculation Flow Rate [^]	L/min	8	16	24
Recommended Minimum Temperature Loss in Recirculation Circuit	°C	2	2	2
Weight – Empty	kg	38	56	73
Indoor/Outdoor		yes	yes	yes

ULTRA VIOLET DISINFECTION

Model		940 00100	940 00200	940 00200
Nominated Maximum Flow Rate	L/min	83	250	250
Weight – Empty	kg	15	15	15
Electrical rating 240v 50Hz	Watts Amps	216 0.9	480 2.0	480 2.0
Viewing Window		yes	yes	yes
Audible Lamp Fail Alarm		yes	yes	yes
Volt Free Contacts for Remote Alarm		yes	yes	yes
Hours Run Meter		yes	yes	yes
Indoor/Outdoor**		yes	yes	yes

[^] At mid blend and equal dynamic supply pressures.

* It is recommended the ultra violet disinfection system lamps be de-energised if the outlet temperature exceeds 50°C.

**UV chamber must be installed under cover when installed outdoor.

Warm Water Roughing in Dimensions

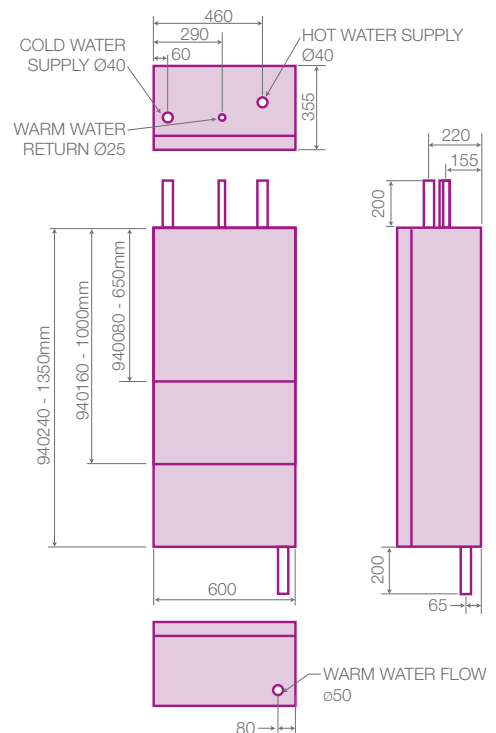

Roughing in dimensions of 940 00100 UV Disinfection

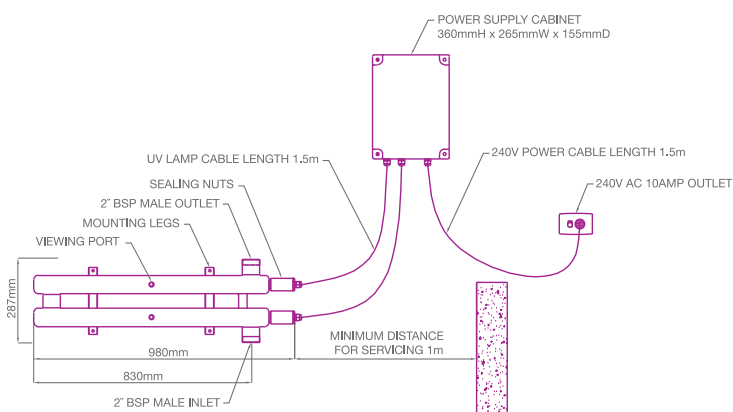

Roughing in dimensions of 940 00200 UV Disinfection

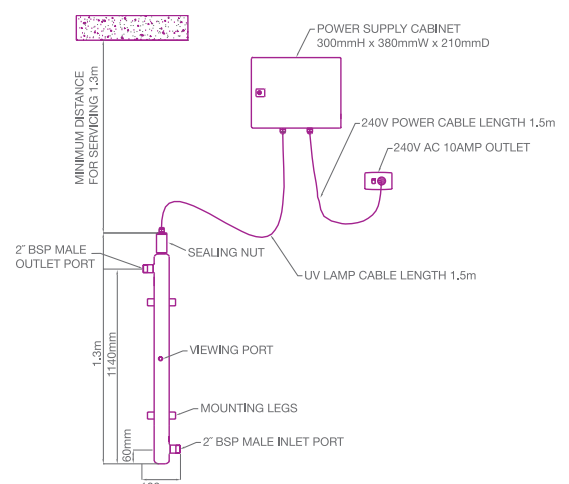

STORAGE TANKS

Market-leading storage tanks from small to large.

When looking for a hot water system for the Golden Grove Helping Hand project, some of the storage tank details considered included maximising the solar hot water storage capacity while minimising the plant room spatial requirements, longevity of the storage vessels, available water connection points, and the ability to manoeuvre through standard plant room doorways.

The Rheem RT2000 tanks were chosen to meet these requirements and, coupled with Rheem solar panels, Tankpak system and Crossflow heat exchanger, have allowed the available plant room space to be maximised while providing room for future expansion of the system.

Rob Horn,
Hydraulic Engineer

CASE STUDY

HEALTH INNOVATION BUILDING

North Terrace, SA

Challenge

The Health Innovation Building at the University of South Australia is a sophisticated \$247 million cancer research facility. A highly robust and cost-effective water heating solution was required for laboratory hand washing, in addition to bathroom facilities for 800 staff members.

Hot Water Solution

The Rheem solution encompassed a domestic hot water plant and a laboratory hot water plant, providing 5330 litres of hot water over a one hour peak period and 22,828 litres per hour for the laboratory and hot water requirement for staff members. Rheem Tankpak Series 2 in combination with 13 x Commercial Storage Tanks was chosen based on the compact design, the ability to rapidly heat large quantities of water at high efficiencies, top down heating system, redundancy and certification for crane lifting.



RHEEM 610 SERIES

SUITED TO INTEGRATION
WITH ALMOST ANY SYSTEM



LARGER
ANODE

50 mm
HIGH FLOW
CONNECTION

NO
PRESSURE
DROP



The workhorse storage system that keeps on working, in a wider range of water quality environments.

Flexible

Compatible with CFWH, Raypak, solar preheat and heat pump storage, or as additional storage, for a Rheem gas or electric hot water system.

Highly durable in poor water quality areas

Manufactured with commercial grade vitreous enamel and larger anode.

Stable pressure

No coils mean there's virtually no pressure drop.

More key features

- Suitable for up to 82° C for sanitising applications
- Range of sizes
- 50mm high flow water connections
- Ease of fitment and replacement



Rheem 610 Series warranty: 5 years on cylinder, 1 year on parts & labour

TECHNICAL DATA

DIMENSIONS AND TECHNICAL DATA TABLE				
Model number			A610340	A610430
			vitreous enamel	
Storage capacity	Litres		325	410
Dimensions	A	mm	1640	1840
	B	mm	640	685
	C	mm	640	685
	D	mm	1008	1210
	E	mm	115	108
	F	mm	-	-
	G	mm	-	-
	H	mm	-	-
	J	mm	290	273
	P	mm	-	-
Q	mm	-	-	
K	degrees	-	-	
L	degrees	90°	84°	
M	degrees	32°	30°	
N	mm	290	273	
Weight Empty	kg		96	117
Inlet/Outlet Connections (BSPF)			RP2	RP2
T&PR Valve Connection (BSPF)			RP¾	RP¾
Vent Connection (BSPF)			-	-
Drain Connection (BSPF)			-	-
Remote Thermostat Connection (1 x thermowell supplied)			RP½	RP½
T&PR Valve Setting	kPa		1000	1000
Expansion Control Valve (ECV)* Setting	kPa		850	850
Maximum Water Supply Pressure				
without ECV* fitted	kPa		800	800
with ECV* fitted	kPa		680	680
Maximum Stored Water Temperature	°C		82	82
Manifold – Min. Centre to Centre	mm		890	935
Maintenance Rate	kWH/day		3.1	4.3

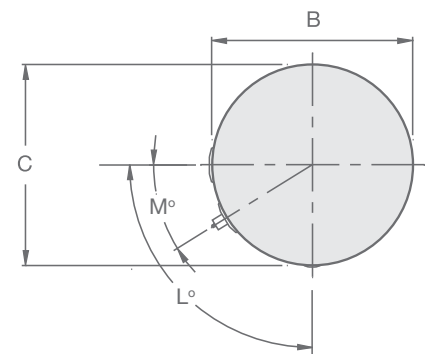
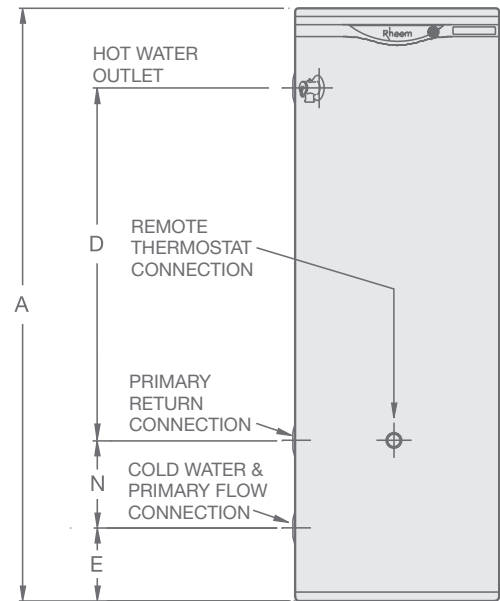

*Expansion control valve (ECV) not supplied with the water heater.

RHEEM RT SERIES

SUITED TO LARGE
COMMERCIAL
APPLICATIONS



EASY TO
INSTALL



HIGH
PRESSURE



UP TO 5,000L
CAPACITY

SUPERIOR
INSULATION



The high pressure, high capacity storage tank.

High pressure

Carbon steel tanks suit 500kPa operation, and stainless steel tanks suit up to 850kPa operation. That's up to 20% more operating pressure than competitor tanks of an equivalent size.*

High capacity

Available in nominal 1000, 2000, 3000, 4000, 5000L capacities. Multiple tanks of the same capacity can be manifolded in parallel to store larger volumes for reduced footprint and installation flexibility.

Easy to install

The only large capacity tank to fit through a single door, the RT1000 tank is just 800mm and can be easily installed in replacement situations. Models up to RT4000 tank fit easily through a double 1400mm door.

High performance insulation

100mm polypropylene insulation, with a bonded aluminium cladding suitable for outdoor installation. Polypropylene insulation is rot and fireproof, resistant to moisture, mould, bacteria, and rodents, hypoallergenic, 100% recyclable, lightweight and self-supporting.

Withstands high temperatures

Can store water up to 90°C.

More key features

- Available in a fully welded carbon steel cylinder for indirect applications, or 316L stainless steel for direct water applications.
- Flange plates and a variety of high flow 50mm water fittings allow for different auxiliary options such as heat exchange coils (not supplied), electric heating unit bundles (page 38), heat pumps, gas water heaters, solar or waste heat.



*Refer to table on next page

Rheem RT Series warranty: 8 years on SS cylinder, 5 years on CS cylinder,
1 year on parts & labour

TECHNICAL DATA

DIMENSIONS AND TECHNICAL DATA TABLE

Model number		RT1000	RT2000	RT3000	RT4000	RT5000
		stainless steel / carbon steel				
Storage capacity*	Litres	920	2055	2960	3820	5180
Dimensions	A mm	2200	2565	2845	2918	3128
	B mm	1000	1300	1450	1600	1800
	C mm	800	1100	1250	1400	1600
	D mm	510	555	600	628	747
	E mm	1435	1735	1945	1963	2132
	F mm	417	462	505	533	667
	G mm	879	1024	1135	1163	1287
	H mm	1341	1586	1765	1793	1907
	J mm	1803	2148	2395	2423	2527
	P mm	685	988	1140	1290	1378
	Q mm	80	100	100	100	100
K degrees	50	50	50	50	50	
L degrees	35	35	35	35	35	
M degrees	75	75	75	75	75	
Weight Empty	kg	136/115	245/245	330/334	455/455	660/535
Inlet/Outlet Connections (BSPF)		RP2	RP2	RP2	RP2	RP2
T&PR Valve Outlet Connection (BSPF)		RP1¼	RP1¼	RP1¼	RP1¼	RP1¼
Vent Connection (BSPF)		RP1½	RP2	RP2	RP2	RP2
Drain Connection (BSPF)		RP1¼	RP1¼	RP1¼	RP1¼	RP1¼
Remote Thermostat Connection (1 x thermowell supplied)		RP1½	RP1½	RP1½	RP1½	RP1½
T&PR Valve Setting (stainless steel/carbon steel)	kPa	850/500	850/500	850/500	850/500	850/500
Expansion Control Valve (ECV)* Setting (stainless steel/carbon steel)	kPa	700/NA	700/NA	700/NA	700/NA	700/NA
Maximum Water Supply Pressure						
without ECV* fitted (stainless steel/carbon steel)	kPa	680/400	680/400	680/400	680/400	680/400
with ECV* fitted (stainless steel/carbon steel)	kPa	550/NA	550/NA	550/NA	550/NA	550/NA
Maximum Stored Water Temperature	°C	90	90	90	90	90
Manifold – Min. Centre to Centre (piping one side)	mm	1350	1550	1700	1850	2050
Manifold – Min. Centre to Centre (piping both sides)	mm	1500	1700	1850	2000	2200
Maintenance Rate	kWH/day	8.5	10.8	12.3	13.5	15.3

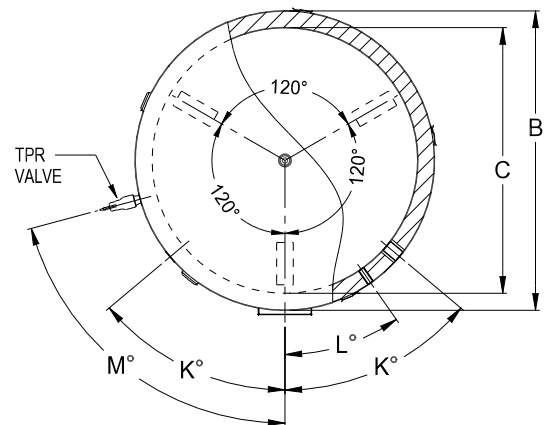
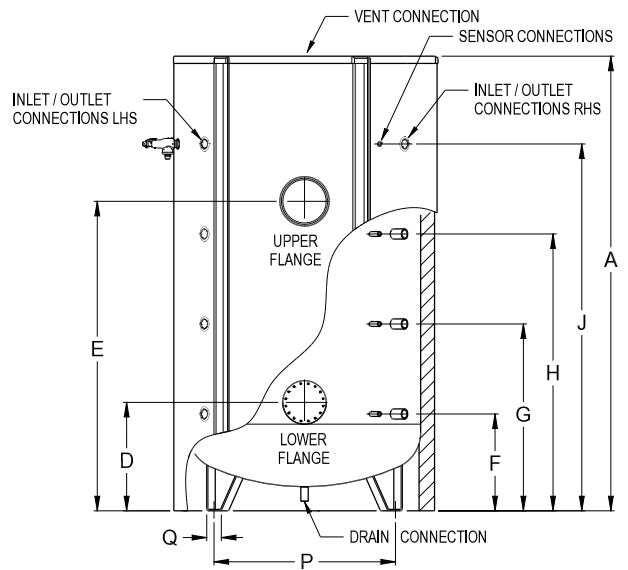

WATER CAPACITY ABOVE NOMINATED DIMENSION (litres)

Model number	RT1000	RT2000	RT3000	RT4000	RT5000	
Storage capacity Litres	920	2055	2960	3820	5180	
Dimensions	J	116	235	309	438	695
	H	345	763	1082	1408	1942
	G	575	1292	1855	2377	3188
	F	804	1820	2628	3347	4435
Upper Flange	E	299	623	861	1146	1489
Lower Flange	D	758	1732	2511	3201	4274

*Expansion control valve not supplied with the water heater.

COMMERCIAL SOLAR

A range of market-leading technologies, ideal for large-scale solar thermal systems or integration into existing systems.

When designing a hot water package, Rheem is a reputable choice to provide an integrated sustainable energy saving solution that satisfies the requirements of our clients.

Adam Fielding,
Partner, Perth Office Manager,
Senior Electrical Engineer
FLOTH

CASE STUDY

KATHERINE DISTRICT HOSPITAL

KATHERINE, NT

Challenge

Katherine District Hospital is a critical piece of public healthcare infrastructure catering to patients from some of the most remote communities in the Northern Territory, servicing an area of 336,674 km². The hospital needed a major hot water system upgrade, converting from an old heat exchange system to an electric-boosted solar pre-heat system.

Hot Water Solution

Rheem provided a renewable energy solution comprised of 24 x Solar Collectors and 3 x RT1000 Stainless Steel Commercial Storage tanks to store the high percentage of solar contribution. The new system services 11 bedrooms, 2 delivery-birth suites, 2 theatres and 3 utility rooms. The tanks were craned to the rooftop, and the pipe work was manifolded to allow ease of tank replacement at end-of-life.



LOLINE DIRECT SOLAR

SUITED TO MOST COMMERCIAL AND INDUSTRIAL APPLICATIONS



FAST INSTALLATION

OVERHEATING PROTECTION

50 mm HIGH FLOW FITTINGS

BMS CAPABLE

The most efficient direct solar system to use and install.

Highly efficient

Unlike evacuation tube technology, Loline has no progressive efficiency loss.

By providing prolonged energy savings, it is a more efficient solar option at typical hot water temperatures.

Save time on site

Utilising the collector's internal header along with a unique expansion tube, Loline allows up to 24 collectors in a row to be quickly and easily connected.

Multiple installation options

A range of tank capacities and any number of solar collectors can be arranged in a variety of combinations, with tanks mounted at the same level or below the collectors to suit site requirements.

Automatic overheating protection

During low-use periods, small amounts of hot water are automatically transferred to storage tanks to prevent collectors overheating. An optional 3-way valve can divert this excess energy to the building recirculation circuit, further reducing operating costs.

Partial frost protection

Warranted against freeze damage in areas below 400m altitude, and an optional electric or gas water heater can be incorporated in the design to assist freeze protection.

Multiple boost options

Boost options include heat pump, gas, or electric, and large tanks can be boosted at the top of the solar tank, minimising footprint.

More key features

- Select from 325L and 410L vitreous enamel storage tanks or RT1000 to 5000 stainless steel storage tanks



SOLAR RADIATION DATA

Collector to Tank Ratio – NPT200										
Location	Latitude	Solar Radiation (MJ/m ² /day)	Best Solar Month	Zone	A610340		A610430		per/1000 litres (RT1000-5000)	
					Min	Max	Min	Max	Min	Max
Darwin	12°	24.7	August	1	2.0	3.0	2.5	4.0	6	9.5
Cairns/ Townsville	17° 19°	24.0	September	1	2.3	3.5	2.8	4.0	6	9.5
Brisbane	27°	23.2	January	3	2.0	3.0	2.5	4.0	7	11
Perth	32°	28.9	January	3	2.0	3.0	2.3	3.5	6	9
Sydney	34°	23.5	December	3	2.2	3.5	2.7	4.0	7	10.5
Adelaide	35°	28.2	January	3	2.0	3.0	2.4	3.5	6	9
Canberra	35°	27.0	January	3	2.0	3.0	2.5	4.0	6	9.5
Melbourne	38°	24.4	January	4	2.0	3.1	2.5	4.0	6.3	10
Hobart	42°	23.6	January	4	2.4	3.5	3.0	4.5	7.5	11
Auckland	36°	23.1	December	2	2.0	3.0	2.4	3.5	2.4	3.5
Wellington	41°	20	November	2	2.0	3.0	2.4	3.5	2.4	3.5
Christchurch	41°	22.2	December	2	2.0	3.0	2.5	4.0	2.5	4.0
Dunedin	45°	18.9	December	3	2.0	3.1	2.5	4.0	2.5	4.0

Lo Line Direct Solar warranty: 5 years on VE cylinder & collectors, 8 years on SS cylinder, 1 year on parts & labour

TECHNICAL DATA

COMMERCIAL SOLAR PIPE SIZE / PUMP SELECTION / SPEED SETTING – RHEEM LOLINE

Total Number Collectors	Combined Tank & Array Piping Length (m)*	Total Length (flow and return) Between Storage Tanks and Collector Array (m)**											
		10	20	30	40	50	60	70	80	90	100	150	200
15	30	DN20/20-60/1		DN20/20-60/2				DN20/20-60/3		DN20/32-80/2		DN20/32-80/3	
		DN25/20-60/1											
30	53+	DN25/20-45				-		-		-		-	
		DN25/20-60/2		DN25/20-60/3				-		DN25/32-80/2		DN32/20-60/2	
	53++	DN25/20-45				-		-		-		-	
		DN25/20-60/2		DN25/20-60/3				-		DN25/32-80/2		DN32/20-60/2	
45	63+	-		DN25/32-80/3				-		-		-	
	90++	-		DN32/20-45				-		DN32/20-60/3		-	
60	79+	-		DN32/32-80/3				-		-		-	
		-		DN40/20-45				-		DN40/20-60/3		DN40/32-80/3	
	120++	-		DN32/32-80/3				-		-		-	
75	92+	-		-				-		-		-	
		-		DN40/32-80/3				-		-		-	
	111++	-		-				-		-		-	
		-		DN50/20-45				-		-		-	
90	105+	-		-				-		-		-	
		-		DN40/32-80/3				-		-		-	
	159++	-		-				-		-		-	
105	118+	-		-				-		-		-	
	160++	-		-				-		-		-	
120	131+	-		-				-		-		-	
	215++	-		-				-		-		-	

* Total length of pipe inter-connecting tanks and collector arrays.

**Lineal length.

- Notes:
- Pump selections are Grundfos. 20-60 = UPS20-60N, 20-45 = UP20-45N, 32-80 = UPS32-80N
 - UPS20-60N set to speed 3 can be substituted for a UP20-45N, but not the reverse
 - If actual number of panels falls between an array size, use the next biggest array
 - If actual pipe length between tanks and collectors falls between the lengths shown, use the next longest length

+Parallel Array

++ Side by Side Array

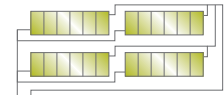
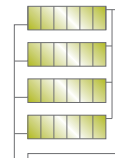

Typical Installation Commercial Solar Loline Double Array

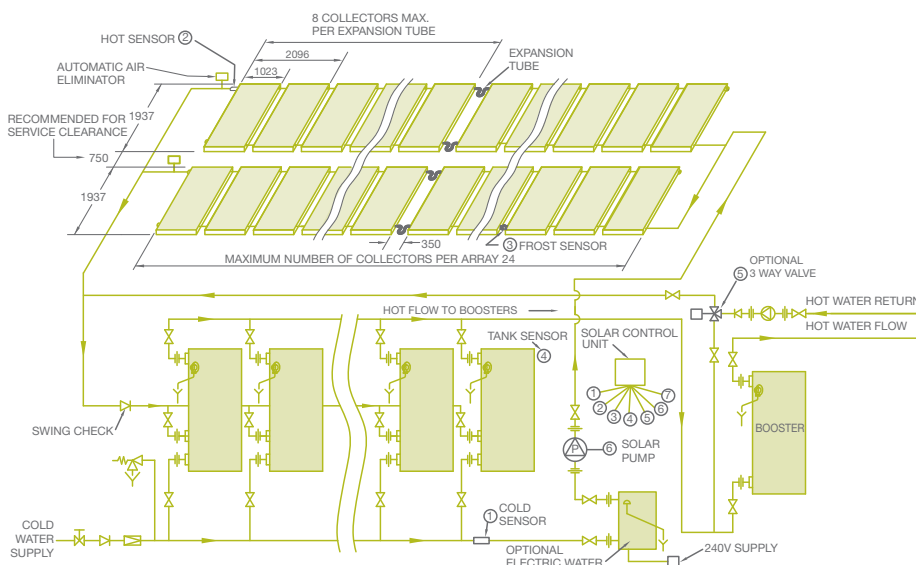

NPT200 COLLECTOR TECHNICAL DATA

Overall Dimensions H x W x D	mm	1941 x 1023 x 80
Aperture Area	m ²	1.86
Weight (empty /full)	kg	36/37
Fluid Capacity	Litres	1.5
Number of Risers		7
Absorber Material		Black Polyester Aluminium
Insulation		Polyester
Glazing		3.2mm Tempered Low Iron
Tray Material		Zincalume®

MINIMUM INCLINATION ANGLE

Auckland	20°
Hamilton	22°
Wellington	25°
Christchurch	30°
Dunedin	35°
Invercargill	37°

HS SERIES DRAIN BACK SOLAR

SUITED TO LARGER APPLICATIONS OR WHERE FROST OR WATER QUALITY ARE A CONCERN



ALL WEATHER & WATER



10% MORE EFFICIENT

50mm HIGH FLOW FITTINGS

BMS CAPABLE

The all-weather, all-water, high-efficiency solar system.

Performs in all weather and water

Because fluid drains back when not being used, the HS Series Drain Back Solar can't stagnate or freeze and, because it's an indirect system, the collectors are protected against scale build-up that can occur in poor water quality areas.

Even more efficient

High performance CSA2013 collectors are made with copper absorber plate and risers, a high absorbing, low-emitting blue Tinox coating and fiberglass insulation - delivering about 10% more efficiency, than other collectors, with no progressive loss of efficiency (unlike evacuated tube technology).

Multiple in-tank boost options

Boost options include heat pump, gas, or electric, and can boost at the top of the solar tank, minimising footprint.

Multiple installation options

A range of tank capacities and any number of solar collectors can be arranged in a variety of combinations. Tanks must be mounted below the collectors.

More key features

- Select from nominal 1000 to 5000L storage tanks
- The package includes high efficiency CSA2013 collectors, high capacity carbon steel RT storage tanks, duty/standby solar pump station for built-in redundancy, and CrossFlow delivery skid, plus selected boost plant



CSA2013 COLLECTOR TECHNICAL DATA

Overall Dimensions H x W x D	mm	1996 x 1043 x 82
Aperture Area	m ²	1.88
Weight (empty /full)	kg	37/39
Fluid Capacity	Litres	1.9
Number of Risers		13
Absorber Material		Copper
Insulation		38mm Glass Wool
Absorber Surface		Tinox Sputtered Selective Surface
Frame Material		Extruded Aluminium
Glass		3.2mm Tempered Low Iron

The collector is mounted in an extruded aluminium tray for superior weather protection and tempered glass improves transmission efficiency.

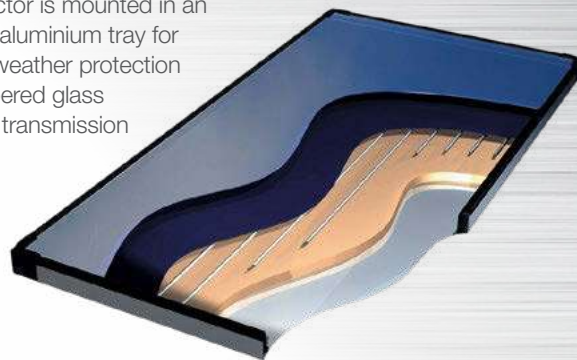

HS Series Drain Back Solar warranty: 8 years on RT stainless steel storage tanks, 5 years on RT carbon steel storage tanks, 5 years on collectors and 1 year on parts & labour

TECHNICAL DATA

Typical Installation HS Series Drain Back Solar

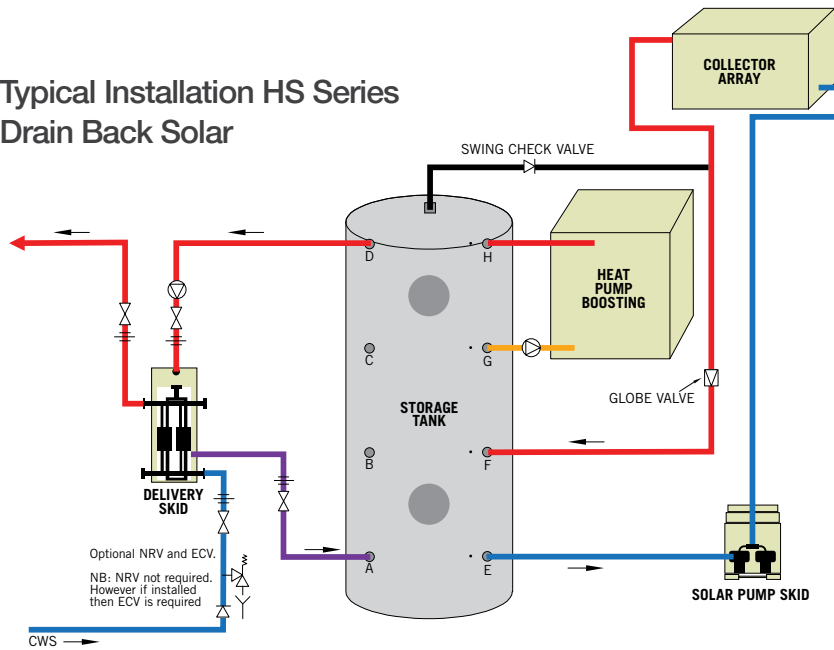

How does it work?

A number of efficient CSA2013 Commercial Solar Collectors are combined with a centralised heat store to extract the sun's free energy and hold it ready for use. Closed circuit fluid is transferred between the heat store and collectors via a Solar Pump Skid with duty/standby cast iron VSD pumps and controller. The controller regulates the pump speed to provide optimal solar energy transfer for improved efficiency.

A highly efficient heat exchanger in the Crossflow Delivery Skid then transfers the stored energy to the potable water supply to meet the hot water requirements on demand.

Installation notes

Solar collectors must be located at least one metre above the top of the storage vessel, and the maximum height from the base of the storage vessel to the top of the collectors should not exceed 40 metres.

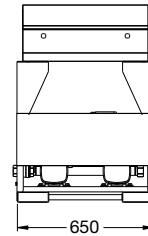

RP013 - RP055

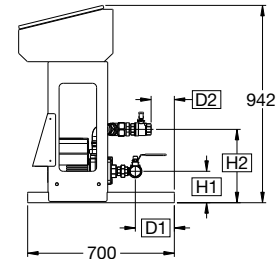

RP103 - RP153

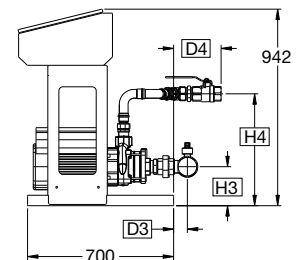

SOLAR PUMP SKID TECHNICAL DATA

Model	RP013- RP035	RP055- RP103	RP153
Weight	80kg	87-169kg	176kg
Electrical Supply	220-240V AC/50-60Hz	380-415V AC/50-60Hz	380-415V AC/50-60Hz
Min Circuit Size	16 Amps	16 Amps	20 Amps

COMMERCIAL SOLAR ID PIPE SIZE AND PUMP SELECTION - HS SERIES							
Number Collectors	Total Height from Base of Storage Tank to Top of Collector (metres)						
	10	15	20	25	30	35	40
8	DN20/RP013		DN20/RP015		DN25/RP015		
12	DN20/RP015		DN25/RP015				
16	DN25/RP015		DN32/RP035				
20	DN32/RP033		DN32/RP035				
24	DN32/RP033		DN32/RP035				
28	DN32/RP055						
32	DN32/RP055						
36	DN65/RP103		DN40/RP055				
40	DN40/RP055						
45	DN40/RP103						
50	DN40/RP103						
60	DN50/RP103						
70	DN50/RP103						
80	DN50/RP103					DN65/RP103	
90	DN50/RP103		DN65/RP103				
100	DN65/RP153						
125	DN65/RP153						
150	DN65/RP153						

SOLAR SKID PUMP								
Model	DIM 'H1'	DIM 'H2'	DIM 'D1'	DIM 'D2'	DIM 'H3'	DIM 'H4'	DIM 'D3'	DIM 'D4'
RP013	150	350	186	111	-	-	-	-
RP015	150	350	153	114	-	-	-	-
RP033	150	350	184	113	-	-	-	-
RP035	150	350	155	115	-	-	-	-
RP055	165	400	104	46	-	-	-	-
RP103	-	-	-	-	167	516	48	310
RP153	-	-	-	-	187	536	66	310

TECHNICAL DATA

Multiple boost options

When solar radiation is low, or there is high hot water demand, the system can be boosted to ensure constant hot water supply. Electric heating unit bundles can be fitted via one of two flanges, and a variety of fittings allow multiple configurations to be connected, such as boosting by auxiliary heat pump or gas water heater.*

* See solar applications guide at <https://rheem.co.nz/products/commercial/solar-products/hs-series/bt-collector>

Electric boosting

- Comes with an adjustable thermostat and visual temperature display.
- Can be interlocked with BMS or solar pump skid to maximise the solar contribution factor (SCF).

Heat pump boosting – 90% free solar

If a Rheem commercial heat pump is chosen for boosting, the heat pump's high Coefficient of Performance will mean you'll achieve up to 90% solar contribution. That's because for typical annual average radiation, 60% SCF can be achieved from solar collectors and 30% from heat pumps. Horizontal models can be stacked two high to reduce plant footprint.

Reduce running costs and energy use even further with optional 3-way valve (available with both Loline + HS Series Drain Back solar).

The available energy in the storage tank can be monitored to maximise solar energy use and reduce running costs.

When there's enough energy in the solar storage tank, the WaterMark Certified 3-way valve diverts building return water to the solar storage. This passes through the in-line boost plant without further heating, using free solar to maintain ring main temperature.

Conversely, when there's not enough energy detected in the solar storage tank, the building return water is diverted through the in-line boost plant to maintain ring main temperature.



Rheem HS Series solar with electric boosting in the top of solar tanks. Katherine Hospital NT.

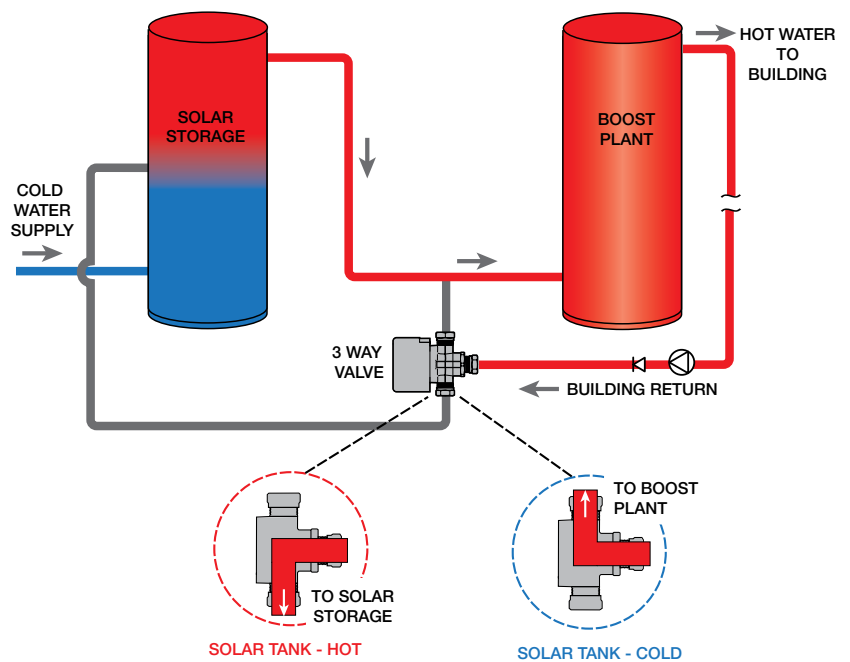

PREMIER HILINE INDIRECT SOLAR

SUITED TO SMALL
ROOFTOP APPLICATIONS
LIKE SPORTS FIELDS



**LIGHTWEIGHT
STAINLESS STEEL**

**ALL WEATHER
& WATER**
SS IS NOT SUITABLE FOR POOR WATER QUALITY



**300L
CAPACITY**

**MULTI-BOOST
OPTIONS**

The simple,
lightweight commercial
solar system.



Lightweight efficiency

The 300L stainless steel storage tank sits on the roof, reducing footprint on the ground, and the thermosiphon design efficiently transfers energy from the collectors into the tank without the need for circulators and primary flow and return lines.

Built-in freeze protection

Uses propylene glycol as the heat transfer fluid to deliver freeze protection to as low as -28°C.

Ideal for scaling water regions

Because it's an indirect system, water never goes through the collector, making it ideal for scaling water areas.

SP2000 COLLECTOR TECHNICAL DATA

Overall Dimensions H x W x D	mm	1996 x 1043 x 82
Aperture Area	m ²	1.88
Weight (empty /full)	kg	45/49
Fluid Capacity	Litres	3.8
Number of Risers		35
Absorber Material		Steel
Insulation		38mm Polyester
Absorber Surface		Black Polyester Powdercoat
Frame Material		Extruded Aluminium
Glass		3.2mm Tempered Low Iron

Typical Installation

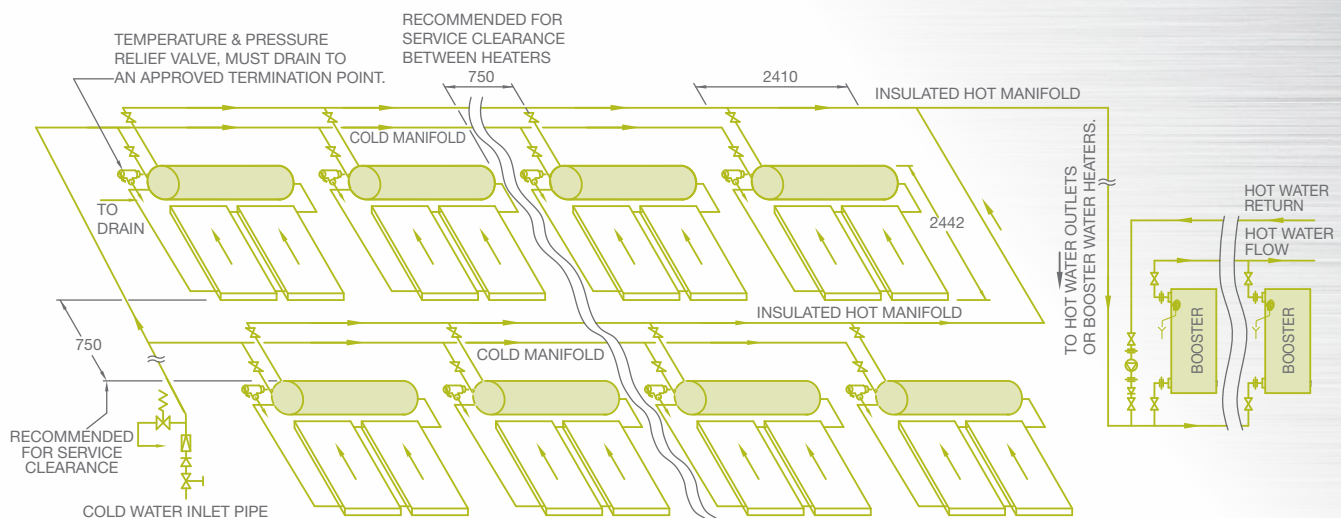

Premier HiLine Indirect Solar warranty: 3 years on cylinder,
5 years on collector, 1 year on parts & labour

INSTALLATION TIPS

Five key tips for delivering maximum performance from your commercial solar system:

1. Collectors should ideally face due north (in the southern hemisphere); facing as far as north-east and north-west will cause approximately 5% drop in operating efficiency.
2. Collectors should be inclined at approximately the latitude angle; however, 15° either way is acceptable, but not less than 10° from the horizontal.
3. For flat roof installations, Rheem can supply variable pitch frames suitable for either one or two collectors with pre-set pitch angles of 20 to 30 degrees in 2.5 increments.
4. Metallic flow and return lines only **MUST** be used between the solar storage tanks and the collectors.
5. The pipe must be well insulated and sheathed if externally mounted.
AS/NZS 3500.4 has guidelines specific to the zone. See the relevant Pipe Size and Pump Selection Table for the correct specification of pipe size.

Collector positioning

Recommended Aspect N.E. to N.W.

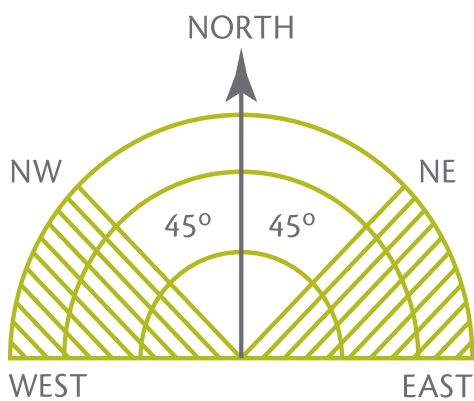

FILTERED BOILING & CHILLED WATER

High-flow, low-fuss boiling water solutions.

Servicing multiple fast food outlets around the clock and across the whole metropolitan area is very demanding.

That's why when it comes to boiling water, I always install Rheem units. They are number one for reliability and have the best service and support.

Rob Thomas,
Lightning Plumbing

*Ready when
you are*



ON-TAP FILTERED BOILING & CHILLED WATER UNDERBENCH

SUITED FOR UP TO 60 PEOPLE. INSTALL OVER SINK OR SINK-FREE (KIT REQUIRED).

FILTERED BOILING 

FILTERED CHILLED 

FILTERED AMBIENT 

Filtered boiling and chilled water, delivering up to 118 cups* of boiling water and 180 glasses* of chilled water per hour.



Clean filtered water

On-Tap features a superior 5 micron filter to reduce impurities and chlorine taste, as well as limescale build-up. A warning light indicates when the filter needs to be easily replaced.

Energy saving

The seven-day timer with programmable sleep mode means your appliance only uses power when needed without compromising on delivery. There is also the ability to set your boiling water temperature between 70-99°C.

Safe to use

Implementing the safety lock for two-finger operation provides extra safety for staff, children and those more at risk. The no-splash, drip-free tap also provides safety at every step of operation.

Hands-free function

Just click the red or blue lever up for continuous boiling or chilled water to fill larger jugs or containers safely.

Flexible installation

On-Tap features modular under-bench heating and chiller units, which provide better options for installation. The sink-free kit enables the tap to be installed on a bench top or boardroom cabinet without a sink (cold water supply and waste required).



Available tap designs

On-Tap is available in two dispenser tap designs – Aqua™ and Azure™.

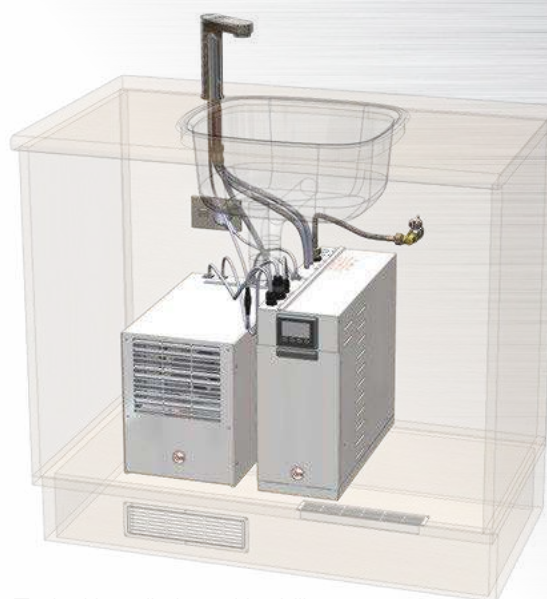

Typical installation with chiller

*All data quoted is taken from Rheem laboratory test reports. The tests are based on a one hour period of delivery and recovery, and are conducted under the same controlled test conditions for all products.

On-Tap warranty: 5 years on tank,
2 years on parts & labour

TECHNICAL DATA

ON-TAP FILTERED, BOILING, CHILLED

AQUA™ TAP & AZURE™ TAP

		BOILING WATER	CHILLED WATER
Delivery – 1 hour	Cups [^]	118	183 ^{**}
Weight empty	kg	12	17
Weight full	kg	18	23
Min water pressure	kPa	300	
Max water pressure	kPa	500	
Electrical rating	220-240VAC 50Hz		
Input	W	1800	200
Electrical connections	10 amp 3 pin plug and flex		
Plumbing connections	R1/2 (BSPM)		
Sound Pressure*	dB(A)	–	50
Product Dimensions			
A – Width	mm	175	250
B – Depth	mm	460	430
C – Height	mm	405	320
Tap Options			
On-Tap Aqua 3L	Part No	743003F	
On-Tap Azure 3L	Part No	743103F	
On-Tap Aqua 5L	Part No	743005F	
On-Tap Azure 5L	Part No	743105F	
Slave chiller only	Part No	UBWC-125	
Aqua sink-free and extension kit	Part No	317453	
Azure sink-free and extension kit	Part No	319042	
Azure base sink-free and extension kit	Part No	319047	

Dispensing Taps

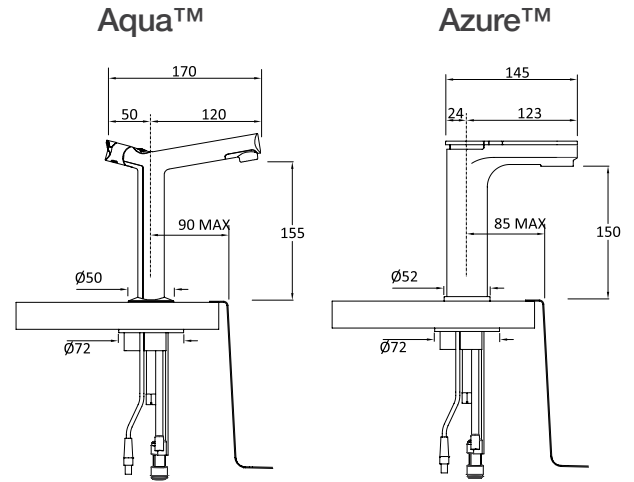

[^] 170ml boiling water cups / 200ml chilled water glasses.

* Measured at 1m horizontally from a closed cupboard at bench height.

** Calculations based on incoming water temperature of 17°C.

OPTIONS

Pumped Chiller & Push-thru Chiller

A separate chiller can be added to provide filtered chilled water from the same tap.

Each chiller contains a ventilation kit.

Only suitable for use with Rheem Aqua™ and Azure™ On-Tap appliances.



318844 Push-thru Compact 1.8L Chiller



UBWC-125 Pumped 5L Chiller

Sink-free kits

Allows for bench top installation where no sink is installed (cold water supply and waste required).

Kit includes:

- Tap extension barrel 60mm for ease when filling tall jugs and glasses
- Outlet fitting
- Separate drain tray and grate (both designs) or combined solid base (Azure™ only)



317453 Aqua™ Split Sink Free + extension kit



319042 Azure™ Split Sink Free + extension kit



319047 Azure™ Base Sink Free + extension kit

ON-TAP PLUS® FILTERED BOILING CHILLED & HOT WATER UNDERBENCH

SUITED FOR 40 TO 60 PEOPLE.
INSTALL OVER SINK ONLY.

FILTERED BOILING 

FILTERED CHILLED 

FILTERED AMBIENT 

HOT & COLD 

More filtered boiling and chilled water than comparable competitors, as well as hot and cold water from the compact under-bench unit.



Delivers more

Delivers 118 cups of boiling water per hour or 57 litres of hot/mixed water per hour (50°C).

Less plumbing needed

Replaces traditional hot water system. Drained safe tray not required. Suitable for single point use only.

Design options

On-Tap is available in two dispenser tap designs – Aqua™ and Azure™.

Also available in two mixer tap designs – Style and Designer.

Clean filtered water

On-Tap features a superior 5 micron filter to reduce impurities and chlorine taste, as well as lime-scale build-up. A warning light indicates when the filter needs to be easily replaced.

Energy saving

The seven-day timer with programmable sleep mode means your appliance only uses power when needed without compromising on delivery. There is also the ability to set your boiling water temperature between 70-99°C.

Safe to use

Implementing the safety lock for two-finger operation provides extra safety for staff, children and those more at risk. The no-splash, drip-free tap also provides safety at every step of operation.

Hands-free function



AQUA™+
STYLE MIXER



AZURE™+
DESIGNER MIXER

Just click the red or blue lever up for continuous boiling or chilled water to fill larger jugs or containers safely.

Compact installation

Designed as a unique split system for flexible installation in tight spaces.

Plus

- ✓ Replacement filter indicator
- ✓ Auto calibration
- ✓ Easy to maintain

On-Tap Plus warranty: 5 years on tank,
2 years on parts & labour

TECHNICAL DATA

ON-TAP PLUS FILTERED, BOILING, CHILLED, HOT				
AQUA™ TAP / STYLE MIXER & AZURE™ TAP / DESIGNER MIXER				
		BOILING WATER	HOT WATER	CHILLED WATER
Delivery – 1 hour	Cups [^]	118	–	183**
Delivery – 1 hour (Litres @ 50°C)	Litres	–	57	–
Weight empty	kg	12	–	17
Weight full	kg	18	–	23
Min water pressure	kPa		300	
Max water pressure	kPa		500	
Electrical rating		220-240VAC 50Hz		
Input	W	1800	–	200
Electrical connections		10 amp 3 pin plug and flex		
Plumbing connections		R1/2 (BSPM)		
Sound Pressure*	dB(A)	–	–	50
Product Dimensions				
A – Width	mm	175	–	250
B – Depth	mm	460	–	430
C – Height	mm	405	–	320
Tap Options				
On-Tap Plus Aqua 5L	Part No	7430054SR		
On-Tap Plus Azure 5L	Part No	7431054DR		
Slave chiller only	Part No			UBWC-125
Aqua sink-free and extension kit	Part No		317453	
Azure sink-free and extension kit	Part No		319042	
Azure base sink-free and extension kit	Part No		319047	

[^] 170ml boiling water cups / 200ml chilled water glasses.

* Measured at 1m horizontally from a closed cupboard at bench height.

** Calculations based on incoming water temperature of 17°C.

Dispensing Taps

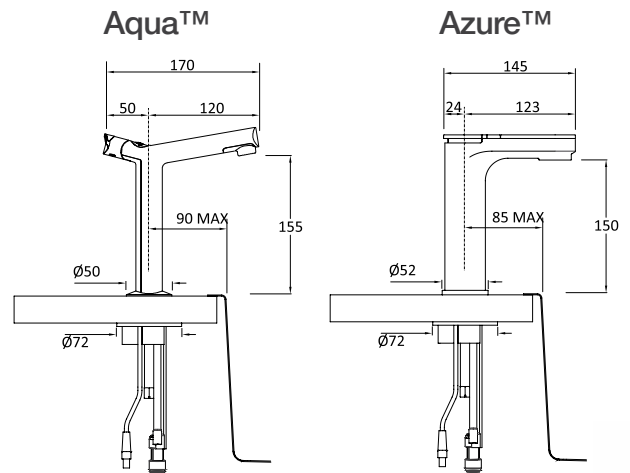

Mixer Taps

Style

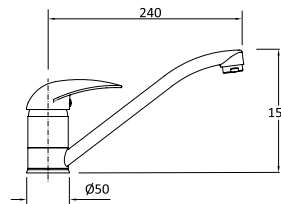

Designer

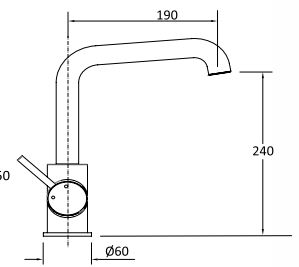

OPTIONS

Pumped Chiller & Push-thru Chiller

With chiller: the product provides filtered boiling and filtered chilled water plus hot water.

Without chiller: the product provides filtered boiling and filtered ambient water plus hot water.

Each chiller is supplied with a ventilation kit for discreet kick-board mounting.

Chiller only suitable for use with Rheem Aqua™ and Azure™ On-Tap Plus range.



318844 Push-thru
Compact 1.8L Chiller



UBWC-125
Pumped 5L Chiller

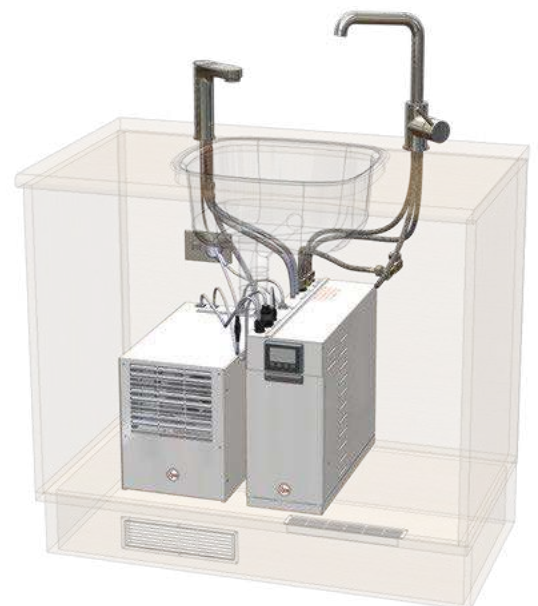

Typical installation with chiller

LAZER® ECO BOILING WATER OVERBENCH

SUITED TO SMALL OFFICE
KITCHENS AND SITE SHEDS



ECONOMICAL



UP TO **50 CUPS**
INSTANTLY



High-flow boiling water units for commercial applications.



Safety first

Optional retrofit tap prevents accidental dispensing with its 3-step action.

Low fuss

Delivers up to 50 cups instantly, with recovery of up to 123 cups per hour. A built-in indicator shows red when heating and green when in energy conservation mode.

Energy management options

One-touch activation button for Eco Mode automatically turns the Lazer® Eco off after two hours with no use. Electronic temperature sensors allow staged filling, more reliable than cistern-valve models, and boiling point is automatically calibrated to installation altitude.

More key features

- Available in 3, 5 & 7.5L
- White enamel

Lazer Eco warranty: 5 years on tank, 2 years on parts & labour

TECHNICAL DATA

LAZER® BOILING WATER UNIT		LAZER ECO		
WHITE POWDER COAT		70303W	70305W	70307W
Capacity	Litres	3	5	7.5
Delivery – Initial	Litres	3.5	6	8.5
	Cups*	21	35	50
Recovery	L/hr	17.5	23	23
	Cups/hr*	103	135	135
Approx Weight Empty	kg	6	8	9
Approx Weight Full	kg	10	15	19
Minimum Water Pressure	kPa	50	50	50
Maximum Water Pressure	kPa	1000	1000	1000
Input	kW	1.8	2.4	2.4
Electrical Connection	supplied with 10 Amp 3 pin plug and flex			
Plumbing Connections	½" BSPM			
Product Dimensions				
A width of unit	mm	283	336	336
B depth of unit excluding tap	mm	160	192	192
C height of unit	mm	435	465	515
D depth of unit including tap	mm	280	312	312

*Cup size is 170ml

Lazer Eco (703 Series)

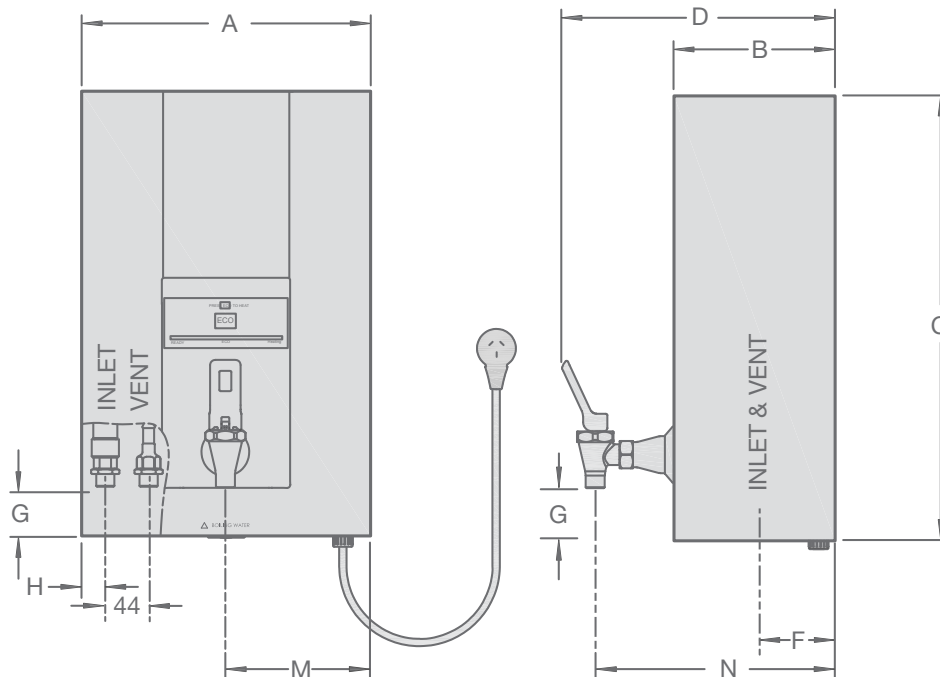

LAZER® COMMERCIAL BOILING WATER OVERBENCH

SUITED TO COMMERCIAL KITCHENS, SPORTING CLUBS & LARGE WORKPLACES



35% FASTER FILLING

UP TO 247 CUPS INSTANTLY

SLEEP MODE



ROBUST



The high-flow, high-capacity boiling water unit.

High flow

High-flow tap saves time with up to 35% faster filling compared to other like-for-like units.

High capacity

Fill pots as well as cups: this unit delivers up to 247 cups as fast as it can be drawn, with a recovery of between 135 and 265 cups per hour.

Energy management options

The user interface allows people to easily adjust temperatures. A seven-day programmable timer turns energy off when boiling water isn't needed.

Sleep mode turns off the system automatically when it hasn't been used for two hours. Electronic temperature sensors allow staged filling, more reliable than cistern-valve models, and boiling point is automatically calibrated to installation altitude.

Robust manufacture

All ranges come with copper tanks, a high water supply pressure rating (1000kPa) and optional filter kit for water protection and improved water taste. There are also automatic safety devices to safeguard the unit against boiling dry.

More key features

- Available in 7.5, 10, 15, 25 & 40L
- White enamel or stainless outer jacket



Lazer Commercial warranty: 5 years on tank, 2 years on parts & labour

TECHNICAL DATA

LAZER® BOILING WATER UNIT		LAZER® COMMERCIAL				
WHITE POWDER COAT		70207W	70210W	70215W	70225W	70240W
STAINLESS STEEL		70207S	70210S	70215S	70225S	70240S
Capacity	Litres	7.5	10	15	25	40
Delivery – Initial	Litres	8.5	11	17	27	42
	Cups*	50	65	100	159	247
Recovery	L/hr	23	23	23	35	45
	Cups/hr*	135	135	135	206	265
Approx Weight Empty	kg	9	10	15	17	19
Approx Weight Full	kg	19	22	34	47	67
Minimum Water Pressure	kPa	50	50	75	75	100
Maximum Water Pressure	kPa	1000	1000	1000	1000	1000
Input	kW	2.4	2.4	2.4	3.6	4.6
Electrical Connection		Supplied with 10 Amp 3 Pin Plug and Flex			Hard wired	
Plumbing Connections		½" BSPM				
Product Dimensions						
A width of unit	mm	336	336	336	336	490
B depth of unit excluding tap	mm	192	192	299	299	340
C height of unit	mm	515	615	515	720	615
D depth of unit including tap	mm	312	312	419	419	460

*Cup size is 170ml

Lazer Commercial (702 Series)

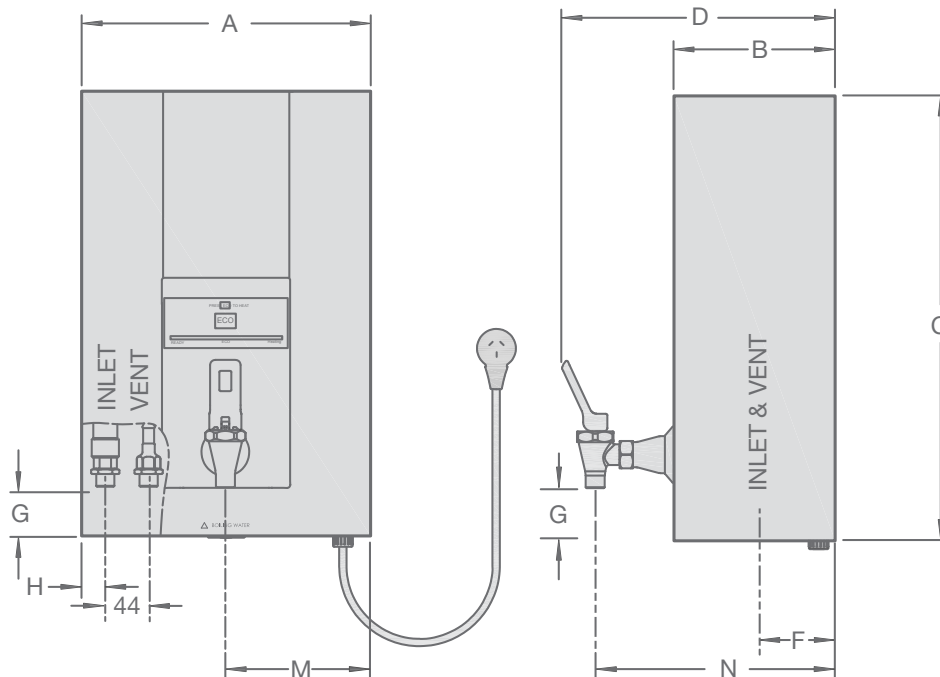

LAZER® OFFICE BOILING WATER OVERBENCH

SUITED TO SMALL OFFICE KITCHENS



SLEEP
MODE



UP TO

35 CUPS
INSTANTLY



The Rheem Lazer®
Office offers elegance
with efficiency.

Lazer® Office

- Available in 3L & 5L (20 & 35 cups)
- Recovery of up to 135 cups per hour
- Consumer choice of powder coated white & easy clean stainless steel

Low energy consumption

- Seven-day timer ensures efficiency when boiling water is not required by turning the energy off.
- Sleep mode will turn off the system automatically when it has not been used for a set period of time.

Concealed tap

- Press the concealed tap for instant boiling water or pull the tap for hands-free filling.
- The user interface allows people to easily adjust temperatures.



TECHNICAL DATA

LAZER® BOILING WATER UNIT		LAZER® OFFICE	
WHITE POWDER COAT		70103W	70105W
STAINLESS STEEL		70103S	70105S
Capacity	Litres	3	5
Delivery – Initial	Litres	3.5	6
	Cups*	21	35
Recovery	L/hr	17.5	23
	Cups/hr*	103	135
Approx Weight Empty	kg	6	8
Approx Weight Full	kg	10	15
Minimum Water Pressure	kPa	50	50
Maximum Water Pressure	kPa	1000	1000
Input	kW	1.8	2.4
Electrical Connection	Supplied with 10 Amp 3 Pin Plug and Flex		
Plumbing Connections	½" BSPM		
Product Dimensions			
A width of unit	mm	285	334
B depth of unit	mm	209**	241**
C height of unit	mm	435	465

*Cup size is 170ml

**Includes 25mm for supplied backing plate

Lazer® Office

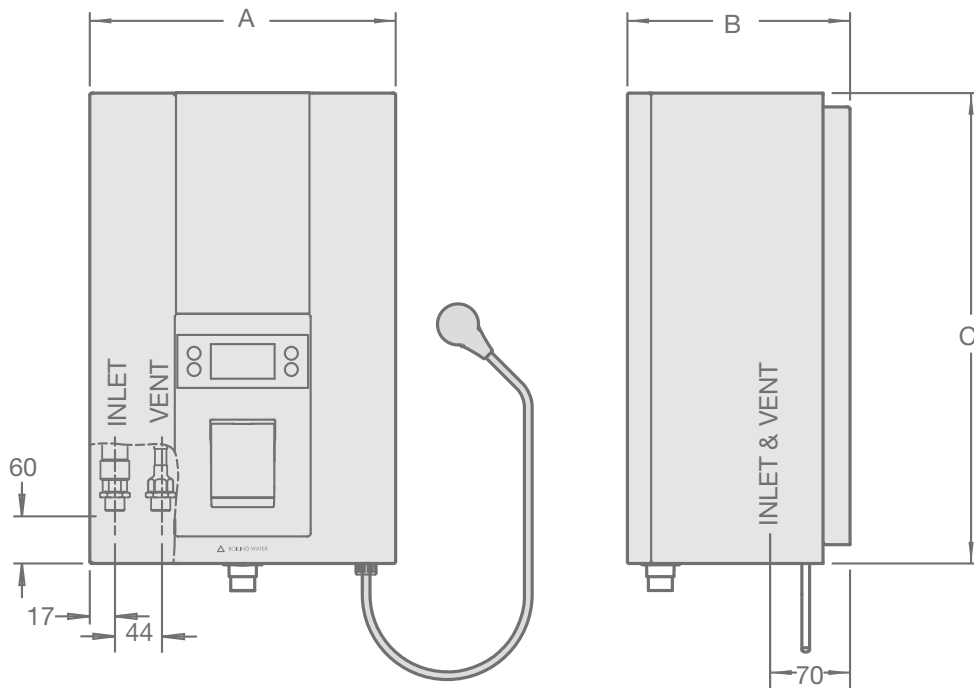

WHICH RHEEM PRODUCT IS RIGHT FOR ME?

FILTERED BOILING



FILTERED CHILLED



FILTERED AMBIENT



HOT & COLD



UNDERBENCH – BOILING WATER APPLIANCES

Each On-Tap suggested for 40 to 60 people

BENCHTOP - BOILING WATER APPLIANCES



Aqua™ On-Tap
3L Boiling Appliance
743003F



Aqua™ On-Tap
5L Boiling Appliance
743005F



Azure™ On-Tap
3L Boiling Appliance
743103F



Azure™ On-Tap
5L Boiling Appliance
743105F



Aqua™ On-Tap Plus 5L Boiling Appliance
7430054SR



Azure™ On-Tap Plus 5L Boiling Appliance
7431054DR



❄️ Add chiller

Compact Push-thru 1.8L Chiller
318844



Pumped 5L Chiller
UBWC-125



Boiling Water	Incoming Water Temperature	Litres p/hr	Cups* p/hr
On-Tap 5L	20°C	23.4	138
	17°C	20.0	118
	15.5°C	19.5	114
On-Tap 3L	20°C	19.5	115
	17°C	16.6	98
	15.5°C	16.2	95

*Cup size 170ml

Chilled Water	Incoming Water Temperature	Litres p/hr	Glasses* p/hr
Pumped 5L chiller	20°C	22.0	110
	17°C	36.6	183
Push-thru Compact 1.8L chiller	20°C	8.0	40
	17°C	12.5	63

*Glass size 200ml

WALL MOUNTED – BOILING WATER APPLIANCES

WALL MOUNTED - BOILING WATER APPLIANCES



Lazer® Office - 3L
70103W-NZ - White
70103S-NZ - Stainless Steel
Max 124 cups p/hr*

Lazer® Office - 5L
70105W-NZ - White
70105S-NZ - Stainless Steel
Max 170 cups p/hr*



Lazer® Eco - 3L
70303W-NZ - White
Max 124 cups p/hr*

Lazer® Eco - 5L
70305W-NZ - White
Max 170 cups p/hr*

Lazer® Eco - 7.5L
70307W-NZ - White
Max 185 cups p/hr*



Lazer® Commercial 7.5L
70207W-NZ - White
70207S-NZ - S/Steel
Max 185 cups p/hr*

Lazer® Commercial 10L
70210W-NZ - White
70210S-NZ - S/Steel
Max 200 cups p/hr*

Lazer® Commercial 15L
70215W-NZ - White
70215S-NZ - S/Steel
Max 235 cups p/hr*

Lazer® Commercial 25L
70225W-NZ - White
70225S-NZ - S/Steel
Max 365 cups p/hr*

Lazer® Commercial 40L
70240W-NZ - White
70240S-NZ - S/Steel
Max 512 cups p/hr*



Zip® - 4.5L
83204514 - White
Manual fill and boil

Zip® - 7L
83207014 - White
Manual fill and boil

Zip® - 15L
83215014 - White
Manual fill and boil

Zip® - 23L
83223014 - White
Manual fill and boil

Zip® - 34L
83235014 - White
Manual fill and boil

*total of initial delivery and recovery per/hr (cup size 170ml)

Worth considering?
Gain cost advantages by replacing the staffroom jug or kettle with a Rheem Boiling Water appliance. If you have over 20 staff and each person drinks 3 cups of tea or coffee a day, think of the time saved, and the increase in productivity.

BOILING WATER EXTRAS



317453 - Aqua™ Sink Free and extension kit



319042 - Azure™ Split Sink Free and extension kit



319047 - Azure™ Base Sink Free and extension kit



318844 - 1.8L push-thru chiller (includes ventilation kit)



UBWC-125 - 5L pumped chiller (includes ventilation kit)



Retrofit Mounting Bracket
318961 - 3L Lazer® Eco
318962 - 5L Lazer® Eco



317327 - 5 micron remote filter kit for Rheem Lazer® products



317067 - 5 micron replacement filter for Rheem On-Tap products



Safety Tap
319068 - Lazer® Commercial and Zip®



Safety Tap
319069 - Lazer® Eco

PUMP ACCESSORIES

FOR REDUCING ENERGY CONSUMPTION AND PROVIDING REDUNDANCY BACK UP

STAINLESS STEEL

LOCKABLE 

DUAL PUMP

TEMP CONTROL 

Redi-Set dual pump sets provide redundancy backup, and are an ideal means of reducing energy consumption by timing the operation of the pumps when required.

Redi-Set Dual Pump Sets

The systems incorporate Grundfos UPS 20-60N or UPS 32-80N stainless steel pump and manifolds. The complete system is mounted on a galvanized base frame with two holes on each side for easy mounting. The system includes non-return valves and shut-off valves, integrated into a manifold arrangement to allow removal of one pump whilst the other is in operation.

An isolation valve should be installed in the suction and discharge lines for easy maintenance and removal (not supplied). Control panels are grey powder-coated metal and are supplied with an electrical test certificate and wiring diagram inserted on the inside of the control panel door.

Standard Model

The Standard model has one switch: Pump 1/Auto/Pump 2 – mounted on the front panel with auto pump changeover every 12 hours. The panel is key lockable.

Deluxe Model

The deluxe model incorporates separate Pump 1 and Pump 2 Auto/Off/Manual switches and red fault/green run indicator lights on the front panel.

This model incorporates auto pump duty changeover on a time clock basis every 12 hours, and run/alarm outputs for BMS connection.



Standard Model

Deluxe Model

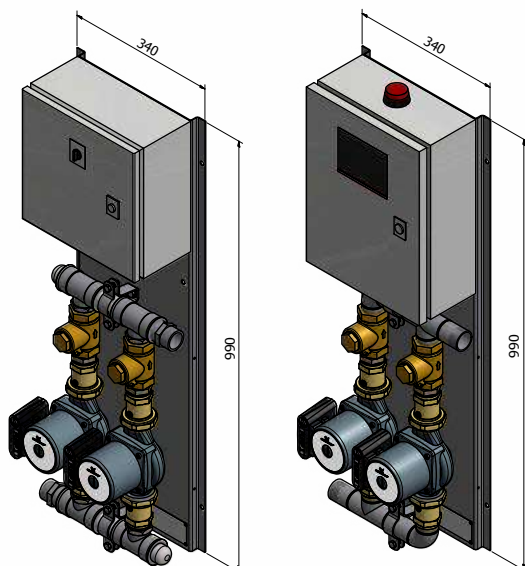

DIMENSIONS AND TECHNICAL DATA TABLE

Circulator Type	UPS 20-60N		UPS 32-80N	
	Standard	Deluxe	Standard	Deluxe
Model Type	Standard	Deluxe	Standard	Deluxe
Model Number	99501270	99501272	99501271	99501293
Liquid Temperature Range °C	2-110	2-110	2-110	2-110
Max. Ambient Temperature °C	40	40	40	40
Max. Operating Pressure kPa	1000	1000	1000	1000
Pipe Connection	BSP R¾	R¾	R1¼	R1¼
Height x Length	mm 990 x 340	990 x 340	990 x 340	990 x 340
Net Weight	kg 24	27	31	33
Electrical Rating	240V/50Hz	240V/50Hz	240V/50Hz	240V/50Hz
Max. Current Amps	0.74	0.74	1.96	1.96
Pump Housing	Stainless Steel	Stainless Steel	Stainless Steel	Stainless Steel
Impeller	Composite, PES/PP	Composite, PES/PP	Composite, PES/PP	Composite, PES/PP
IP Rating of Pumps	IP44	IP44	IP44	IP44
IP Rating of Control Panels	IP54	IP54	IP54	IP54

TECHNICAL DATA

Pump curve UPS 20-60N

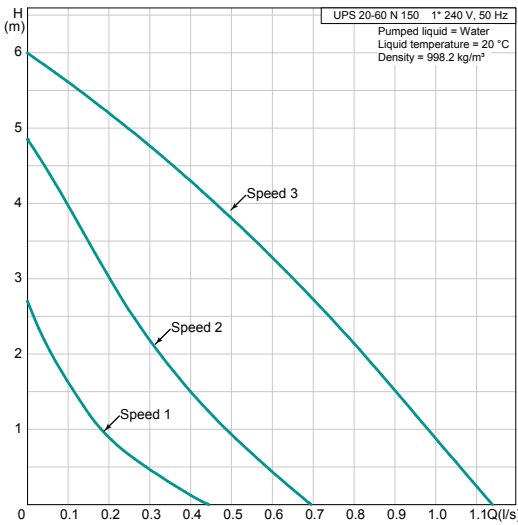

UPS 32-80N

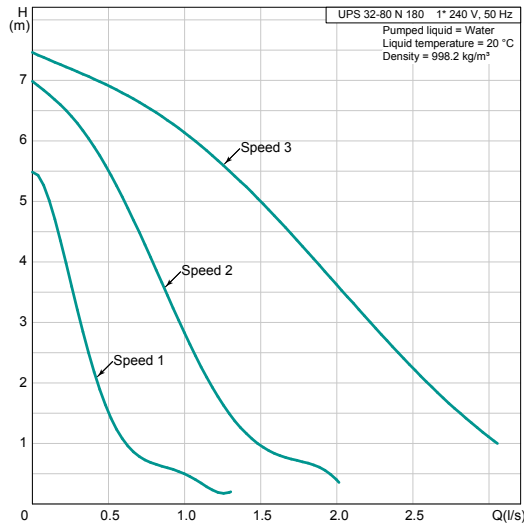

Outdoor cover

Redi-Set pumps can be installed outdoor by installing outdoor covers supplied by Rheem. The part number for the outdoor cover is AQ2051057.

Note: The outdoor cover must be ordered separately for outdoor installation.

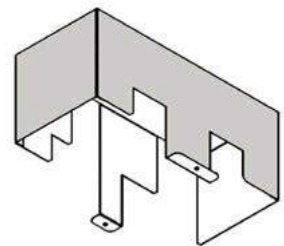

PUMP/C CONTROLLER

The Pump/C controller model 6060262-4 is used to control the circulating pump operation when used in conjunction with a direct or indirect storage tank.

The controller (used in Tankpak concept options & various other hot water control strategies) senses temperature within the storage tank and controls the flow of water by an Operating Thermostat Sensor (Eliwell IC902). This can then turn on a pump, open or close a 3-way valve, etc.

Features

- User display ensures accurate temperature control
- Adjustable thermostat sensor provides flexibility
- Built-in Energy Cut Out Thermostat (ECO) ensures safety and reliability
- Double Pole Double Throw (DPDT) pump control relay with maximum current limit of 6A provides options for a variety of applications



Pump/C Controller warranty: 1 year on parts & labour

RHEEM EQUA-FLOW[®] MANIFOLDING

FLEXIBILITY AND REDUNDANCY

UP TO 10 STORAGE TANKS PER BANK

325-5,000L + REDUNDANCY

← SUPERIOR FLEXIBILITY →

Increase storage and output with Rheem Equa-Flow[®]

Big on water, big on efficiency

If you need large volumes of hot water handled as efficiently as possible, you need to learn about Rheem Equa-Flow[®].

With the Rheem Equa-Flow[®] system, multiple water heaters or storage tanks of the same model can be manifolded to operate as one system.

This means both increased storage and increased output, with each water heater contributing an equal share of the work.

And it's very simple to add more water heaters to the bank, provided the plumbing is altered to keep the cold water inlet to the bank on the end opposite to the hot water outlet.

Circulated flow and return systems

The return line from the recirculation system should be connected to the common cold supply to the water heaters, after the main non-return valve and pressure limiting valve, and before the first cold branch.

The circulator should be isolated by a gate valve on either side and a non-return valve installed after the circulator.

Minimum distance requirements

When you design and install a water heater system using the Rheem Equa-Flow[®] manifold system, it's important to observe the minimum distance requirements between water heaters and obstructions.

This allows for correct operation of the water heaters and access for servicing and maintenance.

Notes

1. In all installations, sufficient space must be left to enable servicing or removal of any water heater. Refer to the product tables on Page 84 for minimum centre to centre distances.



2. The maximum number of water heaters in any bank should be 8 for gas and electric models and 10 for storage tanks. However, several banks can be installed.
3. The hot water line from the manifold must leave from the opposite end to which the cold water line enters the manifold.
4. The hot water header, cold water header and cold water inlet pipe should be a minimum of DN32 pipe and be at least the next nominal diameter above the size of pipe required for the hot water outlet pipe to the system.
5. The cold water inlet pipe and the primary circuit piping should be at least the same size.
6. The hot water outlet pipe and cold water inlet pipe should be the same size, and sized according to the requirements of the particular installation.
7. A non-return valve, isolation valve and, if required, a pressure limiting valve and expansion control valve must be installed on the main cold water supply only, as shown in the diagram.
8. A full flow gate valve or ball valve must be installed on the branches to each water heater.
9. Cold water supply branches to each water heater must be identical. Hot water outlet branches from each water heater must be identical.
10. Non-return valves, pressure limiting valves or loose jumper valves must not be installed in the branch assemblies to each water heater, since preferential flow through one water heater will result.

Equa-Flow[®] principal

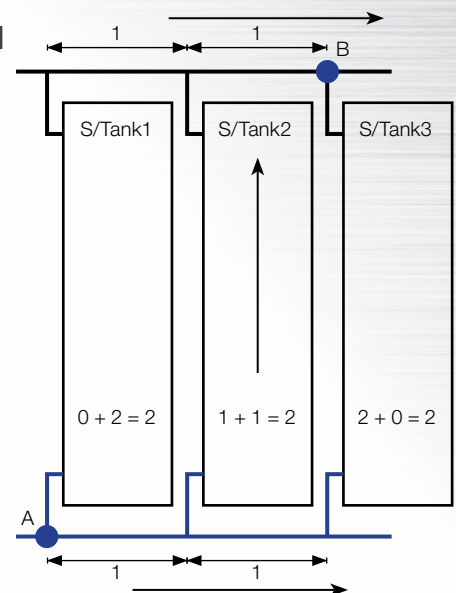

How Equa-Flow[®] works:

From Point "A" thru the first S/Tank1	= 0,	then out of S/Tank1 to Point "B"	= 2	0 + 2 = 2	} Equa-Flow
From Point "A" thru the second S/Tank2	= 1,	then out of S/Tank2 to Point "B"	= 1	1 + 1 = 2	
From Point "A" thru the third S/Tank3	= 2,	then out of S/Tank3 to Point "B"	= 0	2 + 0 = 2	

TECHNICAL DATA

INSTALLATION LAYOUT MINIMUM DIMENSIONS

Model	A	B	C	D	E*	F*
Electric						
A613 050	685	435	250	100	1465	900
A613 315	890	640	250	100	1680	900
A616 315	890	640	250	100	1680	900
Storage						
A610 340	890	640	250	100	1640	900
A610 430	935	685	250	100	1685	900
RT1000	1250	1000	250	100	1985	900
Gas Indoor						
A620260N0	845	595	250	100	1670	900
A624 265	860	610	250	100	1750	900
A624 275	890	640	250	100	1780	900
Gas Outdoor						
A630260N0	920	595	420	420	1670	900
A634 265	920	610	410	410	1710	900
A634 275	890	640	350	350	1780	900

*A distance of 900mm is required for access, servicing and removal of the water heater.

Manifold arrangement

HOT HEADER ASSEMBLY

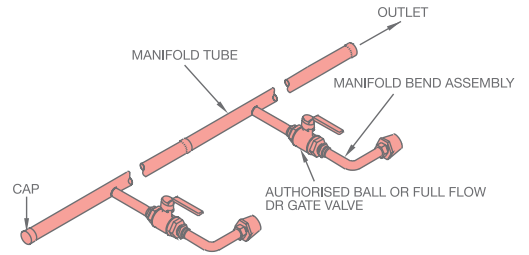

COLD HEADER ASSEMBLY

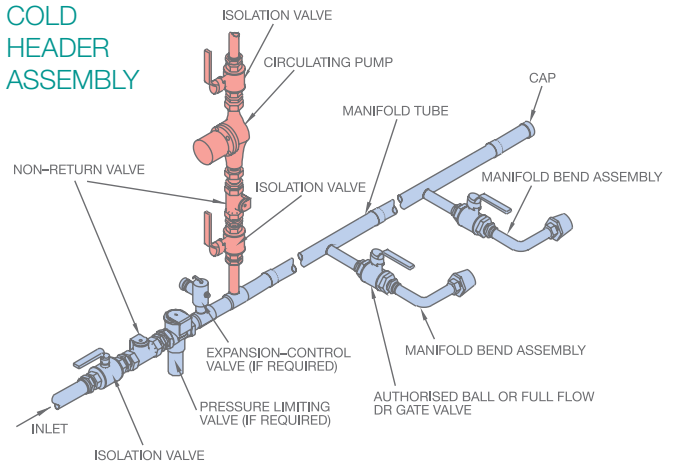

BACK TO BACK MANIFOLD

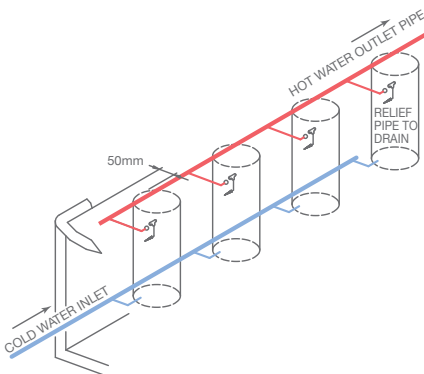
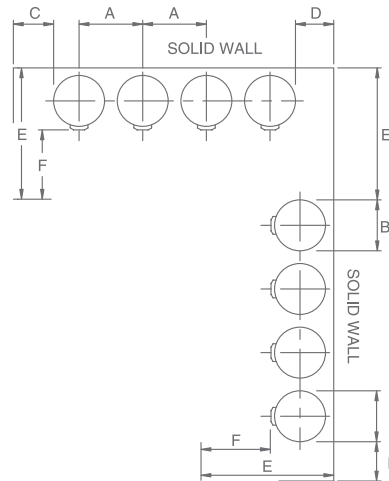
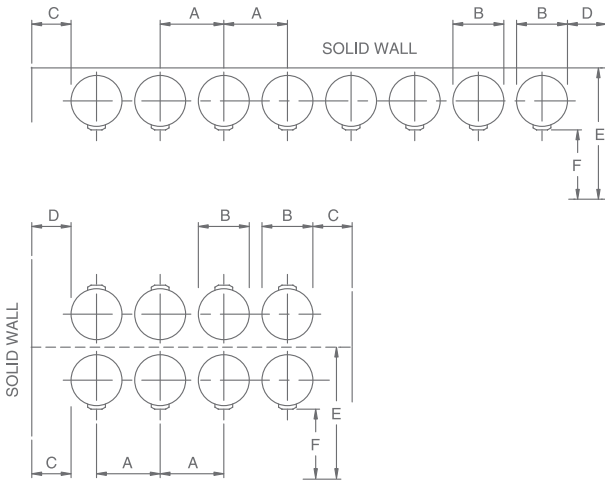

IN LINE

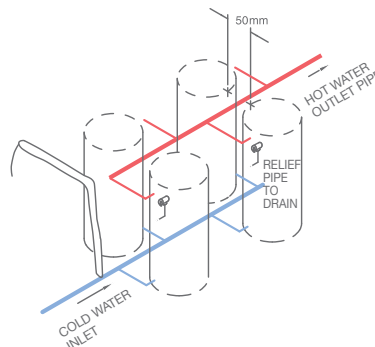

BACK TO BACK

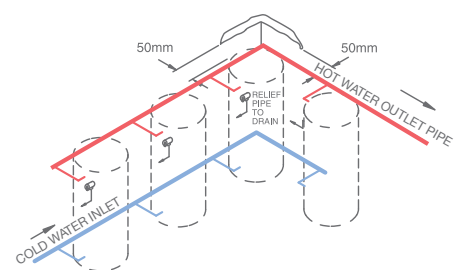

ANGLE

WARRANTIES

RHEEM NEW ZEALAND LTD. - COMMERCIAL PRODUCTS WARRANTY PERIODS

Applicable from the date of Installation for products manufactured after 1 July 2019

MODEL	All warranty periods are in years (parts / labour)							
PRODUCT CATEGORY	PARTS (PRT/LBR)	VE CYLINDER/TANK (LBR)	STAINLESS STEEL CYLINDER TANK(LBR)	VE /CYLINDER TANK (REPLACEMENT)	STAINLESS STEEL CYLINDER (REPLACEMENT)	HEAT EXCHANGER (PRT/LBR)	SEALED SYSTEM (INCL LABOUR)	COLLECTORS/ CARTRIDGE (PRT/LBR)
Commercial Gas Continuous Flow								
Rheem Continuous Flow - Non-domestic*	1					1		
Rheem Tankpak Concept	1	1	1	5	8	1		
Rheem Series 2 Tankpak	1	1	1	5	8	1		
Rheem Multipak	1					1		
Rheem Commpak and Commpak Plus	1					1		
Heavy Duty Storage								
Heavy Duty Commercial incl. Gas, Electric & Storage Tanks - Non-domestic*	1	1	1	5	8			
Heavy Duty Commercial incl. Gas, Electric & Storage Tanks - Domestic*	1	1	1	10	10			
Carbon Steel Tanks 1000-5000L capacities	1				5^			
Raypak Water Heaters								
BO200- 430 NCO PCO, NCM, PCM	1	1				5/1		
BO 507- 4224, NCO PCO, NCM, PCM	1	1				5/1		
Commercial Water Heating Heat Pump Systems								
Comm Heat Pumps / Air 2 Water & Water 2 Water	1	1	1	5	8		2	
Plate Heat Exchanger and Rheem Crossflow	1							
Braised Plate HX and all Crossflow models	1			5	8	1		
Redisets, Pumps and Controllers	1							
Guardian Warm Water Systems								
Warm Water models 940080, 940160, 940240	1						2 /Cartridge only	
UV Disinfection models 940001, 940002 (excludes lamp)	1							
Commercial Solar								
Premier Solar Loline - Non-domestic*	1	1	1	5	8			5
HS Series Solar	1	1	1	5	8			5
Premier Hiline	1		1		3			5
Boiling and Chilled Water Units								
Lazer Office, Eco and Commercial models	2	2		5#				
On-Tap Series Underbench Boiling Water Unit	2	2		5#				
On-Tap Series Chiller Unit UBWC 125	2	2		2#				
On-Tap Series Chiller Unit Push through - 318840	1/0**							

*Domestic= when the appliance is installed in a single family Domestic dwelling.

**Please contact Rheem for further information. (Covered by Waterworks. Warranty Card supplied with instructions)

^Carbon Steel tank used for non potable applications with inhibitor.

#Copper cylinder

SIZING GUIDE

Rheem technical advisory service

This free service is available from Rheem New Zealand Ltd. We can help you size the hot water demand and make recommendations on the type of plant to fit the needs of your project. A call to one of our team will help you save valuable time and effort.

For your next project, whether it be a standard hot water demand or an unusual application, call Rheem on 0800 657 336.

Selection guide

To decide what size of water heater to install, follow the simple steps below:

1. First, determine the peak demand period. (This may be spread over one or more hours. Refer to sizing guide.)
2. Next, calculate the hot water requirements over the peak period. (Refer to sizing guide.)
3. Then select the water heaters that will satisfy the peak demand requirements. (One, two, three or more water heaters can be connected in parallel. Refer to performance chart.) N.B: cold water temperature is needed to determine the appropriate temperature rise.
4. Ensure adequate space is available in the building for the installation. This is of extreme importance, particularly where a number of water heaters are connected in parallel. In allocating space for the installation, consideration should be given to the possible expansion of the system should the hot water demand increase. (See nominal dimensions table.)
5. Consider the advantages of using water heaters designed for outdoor installation ie. no secondary flue required; saving of internal space etc.
6. For an efficient mains pressure commercial or industrial installation, it is essential that the correct pipe sizes be installed.



Note: This sizing guide should be taken as an average only and individual assessment may be necessary.

Caution: In applications where it is known the peak hot water demand will be over a very short period (some showering periods in industry may be no longer than 30 minutes) then the storage and recovery rate of the water heater/s should be calculated for that time period only.

Note: Where hot water is being provided for dishwashing and glasswashing machines etc., it is advisable to check the hot water consumption of a unit with the manufacturer before specifying the water heater.

Service and warranty

Rheem New Zealand Ltd recommends, as a minimum, a yearly service to be carried out on all commercial products. Some products will require a more regular service.

All servicing should be carried out by a qualified suitable licensed professional.

Our systems are backed by a national network of after-sales professionals, so if your product is still within its warranty period and you need a service technician, call 0800 657 336.

SIZING GUIDE		
Application	Suggested peak period	Hot water requirements, at 60°C supply temperature (unless indicated)
Snack bars, take-away food	1 to 2 hours 12 to 1pm or 12 to 2pm	Allow 3.1 litres for each meal. This covers cooking and washing, e.g. 200 meals over 2 hours = 620 litres. Note: water required at 82°C to meet regulations
Canteens, cafes, restaurants, hotel kitchens	1 to 2 hours 12 to 1pm or 12 to 2pm	Allow 5.5 litres for each 3 course meal. This covers cooking and washing, e.g. 200 meals over 2 hours = 1100 litres. Note: water required at 82°C to meet regulations
Holiday flats, hotels, motels, guest houses	1 hour 7.30am to 8.30am	Allow 20 to 25 litres per head over the peak hour, e.g. 40 guests = 1000 litres over 1 hour, for 4 and 5-star accommodation allow 30-45 litres per head
Apartments	1 hour 7:00am to 8:00am	Allow for each type of apartment in the building, e.g. studio = 25 litres, 1-bedroom apartment = 40 litres, 2-bedroom = 75 litres; three bedroom = 90 litres, 4-bedroom = 110 litres and a penthouse = 150 litres
Caravan parks, camping areas	spread over 2 hours	Allow 20 litres per person. Average 4 persons per van, e.g. 30 vans = 120 people = 2400 litres, over 2 hours. Consider also no. of shower units available, allow maximum of 6 showers per hour per shower rose. In parks used mainly for long-term holiday or residential purposes, the peak period may extend over a much longer time. The actual usage pattern should be ascertained
Hairdressing salons	3 to 4 hours	Each installation to be individually evaluated but as a guide, allow 10 litres per customer. Fashion salons may use much more
Squash courts	spread over 4 hours	Allow 20 litres per player. Average 16 players per court over 4 hours e.g. 4 courts = 20 x 4 x 16 = 1280 litres over 4 hours
Office amenities	spread over 8 hours	Allow 3 to 4 litres per person per day. Shower seldom used. Peak usage allow 1.5 litres per person over 1 hour
Factory change rooms (light industry)	1 hour 4pm to 5pm	Average of 30% use showers. Allow 20 litres per head. Average of 70% use hand basins. Allow 3 litres per head. (This is equivalent to 8 to 9 litres per person)
Factory change rooms (heavy or dirty industry)	1 hour 4pm to 5pm	Allow 30 litres per head. Note: in some industries such as mining, 50 litres per head may be necessary
Glass washing machines	usually over 2 hours	Determine quantity of glasses to be washed over peak period. Allow 3 glasses per litre of beer sold. Most machines require 7 litres of hot water per wash of 25 glasses and can handle one wash per minute. e.g. 1000 litres of beer over 2 hours 1000 x 3 x 7 litres ÷ 25 = 840 litres of hot water. Note: 1. Water required at 82°C to meet regulations. 2. Where beer consumption known in gallons, multiply by 4.55 to convert to litres
Coin-operated laundries	spread over 8 hours	Allow 70 litres per machine per hour, e.g. 6 machines 70 x 6 x 8 = 3360 litres over 8 hours. Large commercial laundries allow 10 litres per kg dry washing

Rheem New Zealand Ltd

CUSTOMER SERVICE 0800 657 336 | SERVICE 0800 657 335

475 Rosebank Road, Avondale, Auckland 1026 | www.rheem.co.nz

All warranties managed by Rheem New Zealand Ltd



Rheem New Zealand Limited

Freephone 0800 657 336

Freefax 0800 657 337

Telephone 09 829 0200

475 Rosebank Road, Avondale 1026

PO Box 19011, Avondale,
Auckland 1746, New Zealand

www.rheem.co.nz

All specifications contained in this brochure are subject to change without notice. Please check the specifications are current at the time of ordering or building to incorporate the appliance. All information is current at the time of publication, (August 2020) but may change without notice.

STEADY, HOT & STRONG

INSTALL A RHEEM®

