

# FURNITURE

Systems that find balance in  
technology, sustainability, and craft

## STACKLAB

2026

Jupiter Desk  
© Christopher James Delaney



## Contents

<b>STACKLAB</b>	4
Ash Collection	6
Cube Collection	18
ECC Collection	32
Felt Collection	42
Garrison	50
Geppetto	62
Jupiter Collection	70
Mura Collection	84
Wishbone Collection	92
Audiofile (Commission)	102
Ovoid   Dining Table (Commission)	106
The Selby (Commission)	112
Awards, Fairs & Exhibitions	116
Permanant Collections, Publications, Press & Lectures	119

# STACKLAB FURNITURE

Founded in 2013 by Jeff Forrest, STACKLAB's Furniture division focuses on developing proof-of-concept systems aimed at disrupting waste streams in regional manufacturing. With a strong emphasis on collaboration to improve design outcomes, STACKLAB incorporates a wide range of skills and perspectives into its work. The studio is dedicated to creating innovative collections that harmonize technology, sustainability, and craftsmanship.

STACKLAB founder Jeff Forrest  
Garrison 103-133  
© Rajeshta Julatum



# Ash Collection

The Emerald Ash Borer beetle has significantly impacted ash trees throughout North America. Trees affected by this beetle are often deemed unfit for conventional woodworking. The Ash Collection introduces a fresh perspective and purpose for these trees.

At the heart of the collection lies the digitally-derived geometric ash wood “egg.” This design is not only versatile but also forms the foundation of a diverse furniture system.

The egg’s modular design allows it to be sectioned and reconfigured or paired with joined ash wood boards reclaimed from beetle-affected logs. From this, a cohesive 15-piece suite has been developed, featuring stools, benches, foyer, dining, and console table designs.

In an effort to minimize process waste and storage, the egg pedestal is utilized as tooling, serving as the basis for generating novel 50 percent ash wood, 50 percent refractory sand molds for cast components. These cast pieces, bearing a process specific filigree, then effortlessly integrate with the main pedestal assemblies.

The Ash Collection production process yields less than one percent waste by volume. True to its sustainable ethos, all materials are sourced within an 300-mile radius of STACKLAB’s Toronto studio and assembled locally.



Ash Collection  
© STACKLAB



Prototypes (various) and A4-AP | © Patrick Biller

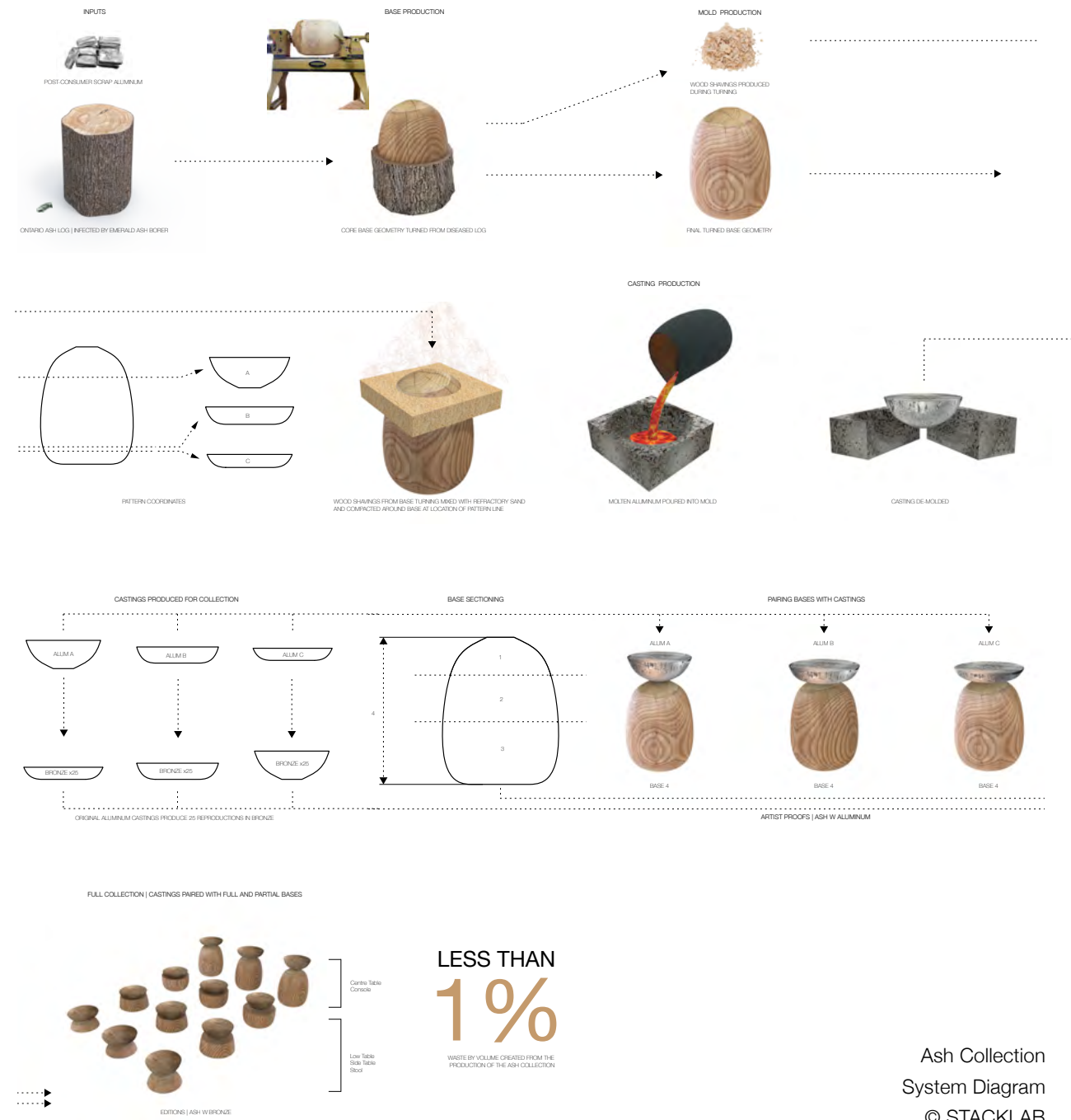

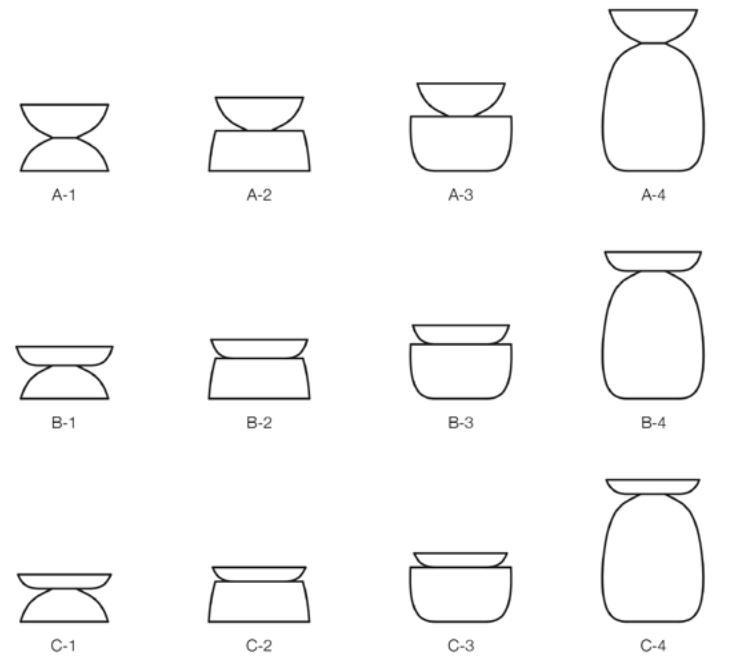

Ash Collection Matrix

Ash Coffee Table Cluster | A3, A1, B2 (off-kilter), C1  
 Cast Bronze and diseased Ash  
 © Douglas Friedman for Gallery Magazine @ Casa Una Privada

Details | B2, A3 (off-kilter)  
Cast Bronze and diseased Ash | © Patrick Biller



Ash Bench Cluster | A2, B2  
Diseased Ash | © STACKLAB



Ash Foyer Table  
© Patrick Biller



Ash Console  
© Mike Van Tassell



Ash Dining Table and Coffee Table Cluster | Eds. 25  
© STACKLAB

# Cube Collection

The Cube Collection celebrates the industrial process that creates molds for producing sand-cast metal parts. As the manufacturing world progresses, many single-use and limited-use patterns become redundant, leading to a surfeit of dormant industrial tooling. STACKLAB, driven by the passion to reincorporate these materials into contemporary production, crafted a unique reuse approach.

The award-winning proof of concept transformed quarter sections of a decommissioned wooden pattern, once instrumental in creating a historic pump, into four unique 16" x 16" x 16" casting formworks. These became vessels for Engineered Cementitious Composite (ECC) – a low-temperature compound that blends recycled glass and fiber.

ECC's properties make it ideal to cloak a lightweight, recycled foam core, yielding a robust inverse replica of the initial pattern. These inverted cubic forms offer versatile adaptability, easily fitting in diverse orientations, be it indoors or out.

Inspired by the initial four casting variations, STACKLAB has expanded the collection with monolithic cuboid coffee tables and consoles. An exquisite touch has been added with the option to adorn the signature casting imprint with 24 karat gold. The Cube Collection now boasts its original cubes, available as individual stools or side tables or clustered bench, ottoman and artwork configurations, and the grander cuboids as standalone coffee tables and consoles.

Over 90 percent of the materials employed in this collection are non-virgin, emphasizing STACKLAB's commitment to sustainable practices.



Cube Collection  
© STACKLAB

ECC (Natural Shade) and Recycled Foam  
One Hundred Barclay, NY  
© Scott Frances for Brad Ford

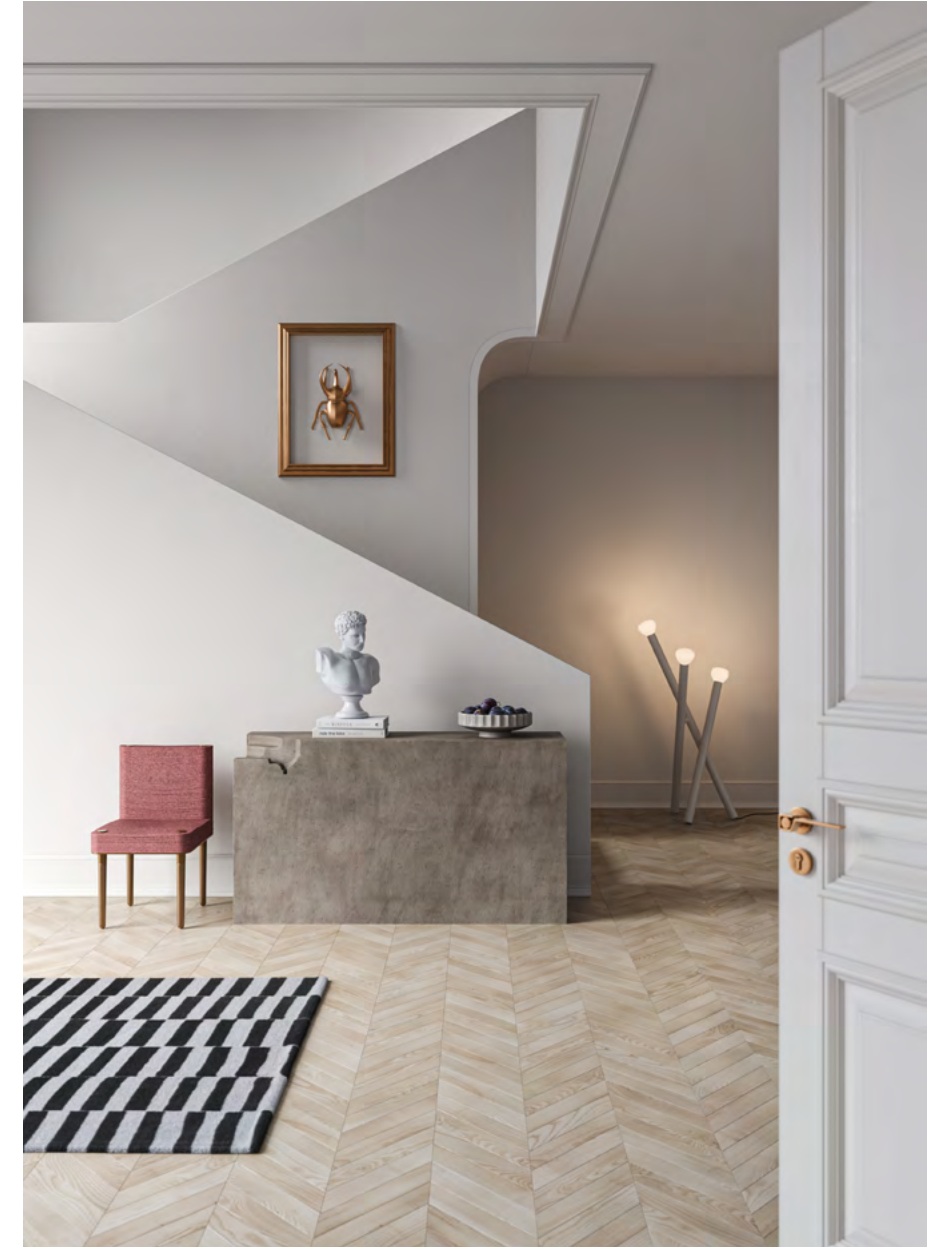
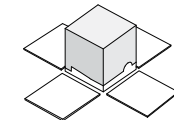
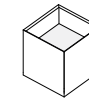
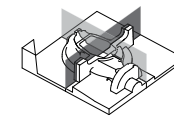

Cube Console | Type B  
ECC (Natural Shade) and Recycled Foam  
© STACKLAB



Holiday House New York 2018  
Robin Kramer Garden Design  
© Courtesy of Holiday House



Kips Bay Showhouse 2017  
Dineen Architecture + Design  
© Peter Rymwid



Salon Art + Design 2016  
© Robert Levin for Maison Gerard and Carol Egan

## Cube Series | Gilded

The original, award-winning Cube Series reintegrates historic industrial tooling into the scaled production of Engineered Cementitious Composite (ECC) stools, benches, ottomans, tables, or artwork. The collection, available in four variations, is made using over 90 percent non-virgin materials

A recent iteration, limited to 10 units per variation includes 24 karat gold – applied to the portion of the casting containing the imprint of the original tooling.



Cube | Type B  
ECC (1000 Black), Recycled Foam and 24 Karat Gold  
Private Residence | © Patrick Biller



Cube | Types A and C  
ECC (1000 Black), Recycled Foam and 24 Karat Gold  
Private Residence | © Douglas Friedman for Carlos David Studio



Cube Coffee Table | Type B  
ECC (1000 Black), Recycled Foam and 24 Karat Gold  
© Mike Van Tassell

# ECC Collection

Informed by detailed research into the Engineered Cementitious Composite (ECC) used in the Cube Collection, STACKLAB introduced a proof-of-concept modular collection that harnesses the material's unique attributes.

Unlike traditional concrete, ECC offers a sleek structural wall section, perfectly suited for surrounding a lightweight core made primarily from recycled rigid foam insulation, a frequent byproduct of construction. Within the ECC Collection, STACKLAB utilized greater concentrations of non-cored ECC for ballast, leading to table bases with a reduced physical footprint.

The original proof of concept focused on single-module foundational pieces like foyer tables, dining tables, and desks. STACKLAB has broadened the scope of the ECC Collection and now presents an expanded range of components for coffee and console tables as well.

A standout feature of this collection is the incorporation of domestic hardwood and stone, allowing users the luxury of selecting between three premium materials for each component.

The ECC Collection symbolizes the synergy between STACKLAB and the esteemed artisans and manufacturers of Toronto, highlighting the contributions of materials engineer and artisan, Alla Linetsky.



ECC Collection  
© STACKLAB



ECC Console  
© Patrick Biller for South Hill Home





ECC Dining Table | 2 Modules  
© Ace Misiunas



ECC Foyer Table  
© Ace Misiunas



ECC Dining Table | 2 Modules  
© Ace Misiunas

# Felt Collection

(Proof of Concept)

North America generates millions of tons of textile waste each year. Disturbingly, despite the vast potential for reuse, only a small fraction of these textiles is recycled, making them a major contributor to landfills. With growing legislative efforts across the continent, the textile industry faces an urgent call to transform and innovate.

STACKLAB's proof of concept Felt Collection emerges as a compelling response to this challenge. These designs are meticulously tailored to incorporate bulk textile waste streams, with an emphasis on optimal use and minimal post-processing. Through advanced proprietary software and close collaboration with leading North American manufacturers within 300 miles of its Toronto studio, the company sources surplus felted Merino wool offcuts and 60 percent recycled PET acoustic board. The materials are then fashioned into bespoke benches, chairs, stools, and ottomans.

The distinctiveness of the Felt Collection is further accentuated by STACKLAB's signature plated-steel clamping hardware, anchoring the textile stacks and achieving modular designs.

Since its debut in 2017, the Felt Collection has served as a case study in repurposing industry remnants and waste products, inspiring the creation of Stackabl ([www.stackabl.shop](http://www.stackabl.shop)).





Felt Armchair, Triangle  
© Stephen Karlisch

Diagram: Transforming Remnants Into Usable Layers.  
© STACKLAB

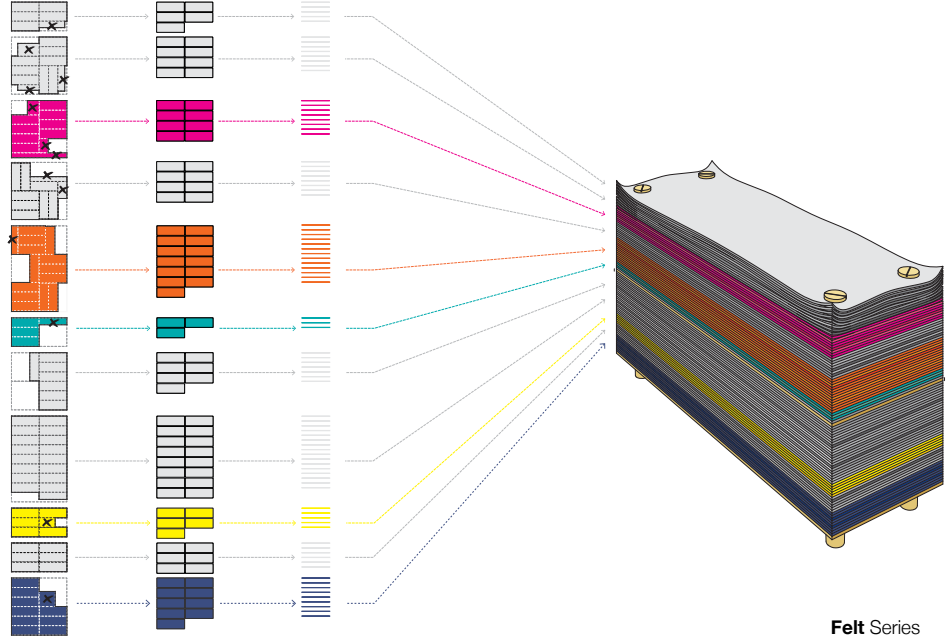

Felt Series



Felt Armchair and Bench for Dennis Miller New York  
© Mike Van Tassell

Felt Collection | Chair  
Private Residence, Toronto, Canada  
© Patrick Biller



Felt Collection | 2/4 Bench  
Felted Merino Wool Remnants, Bronze Plated Steel, and Walnut  
© Patrick Biller for South Hill Home

# Garrison

The original Garrison is a sculptural iron casting designed as both stool and side table. Crafted from two tons of recycled rebar, the collection comprised a limited edition of 102 pieces. The material was sourced from the 2015 dismantling of its namesake, the Garrison Bridge near Toronto's Fort York.

Conceived through a dedicated algorithm, the Garrison balances weight, strength, and manufacturability within a singular form. The inaugural 51 pieces featured a bronze-coated top, which later inspired a further edition: 30 in solid mirror-polished bronze, seven in solid green-patinated bronze, and 10 in solid blue-patinated bronze.

Paying tribute to central and eastern Canada's industrial roots, the Garrison is sand-cast using a traditional method employed in heavy machinery manufacturing. The process produces subtle surface variations that give each piece a distinct tactile character.

In 2026, STACKLAB introduced an open edition of the Garrison in satin bronze, mirror-polished bronze, satin aluminum, and patinated aluminum. This expanded offering extends the material language of the piece while preserving the integrity of its original form and structural logic.

The Garrison is suitable for indoor and outdoor use.





The Garrison Road Bridge during demolition  
© Patrick Thompson

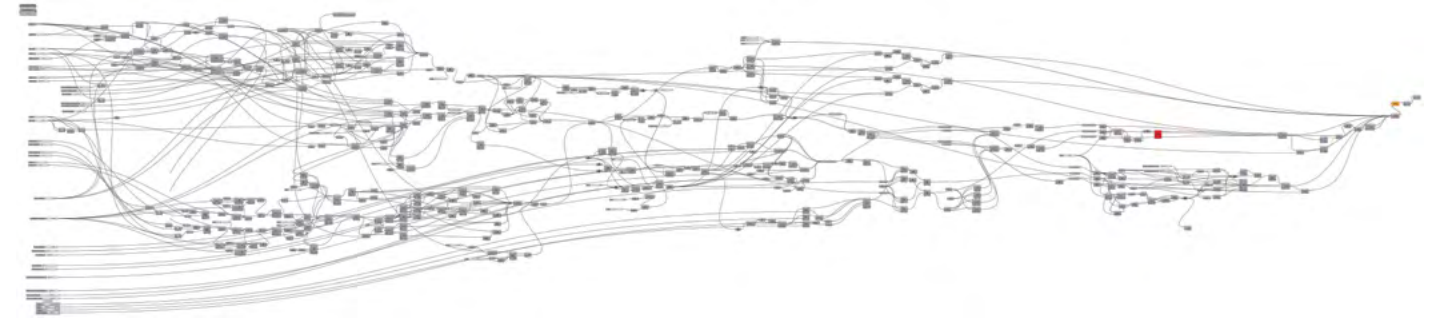

Representation of Garrison parametric script/definition

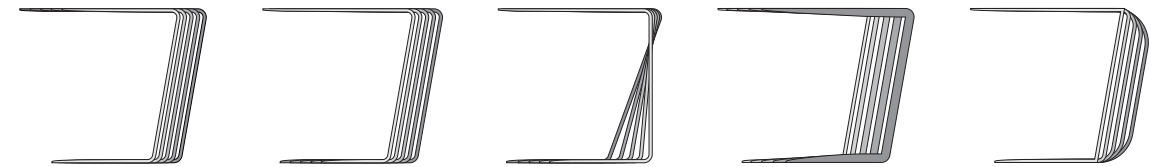

Sample elevation explorations produced from script



© Patrick Thompson



16" W x 14" D x 18" H  
Cast Iron  
© Maison Gerard

16" W x 14" D x 18" H  
Cast Iron, Polished Bronze  
© Maison Gerard



Private Residence  
© Domino magazine for Kimberly Von Koontz and Adrian Gaut

Garrison 103-133  
© Sean McBride



Garrison 103-133 | Solid Bronze  
Private Residence, Toronto, Canada | © Patrick Biller



Garrison 141-150  
Cast Bronze with Blue Patina | © Sean McBride

# Geppetto

Serving as both stool and side table, Geppetto was originally conceived in solid red bronze with a peened finish and mirror-polished top. Cast as a single piece, it features an ergonomic handle opening that reinforces its sculptural utility. The form reinterprets the classic three-legged stool referenced in Carlo Collodi's 1883 fairy tale *The Adventures of Pinocchio* and later popularized by Disney's 1940 film adaptation. Its geometry was refined through parametric modelling, optimizing leg taper, angle, and seat thickness to achieve balance, lightness, and structural integrity within one continuous cast form.

The custom copper-rich red bronze alloy reduces porosity, increases strength, and improves material flow during casting. The elevated copper content enhances corrosion resistance, allowing Geppetto to perform equally well indoors or outdoors while developing a subtle living patina over time.

Reflecting central and eastern Canada's industrial heritage, Geppetto is sand-cast using a method rooted in heavy machinery production. The process produces slight surface irregularities that heighten its tactile character. In 2026, STACKLAB introduced an open edition in polished or satin bronze, polished or satin aluminum, and patinated aluminum, expanding the material language while preserving the integrity of the original form.



Geppetto. Ed 50 | Solid Bronze  
Private Residence, CA | © Frank



Casting the Geppetto © Rajeshta Julatum

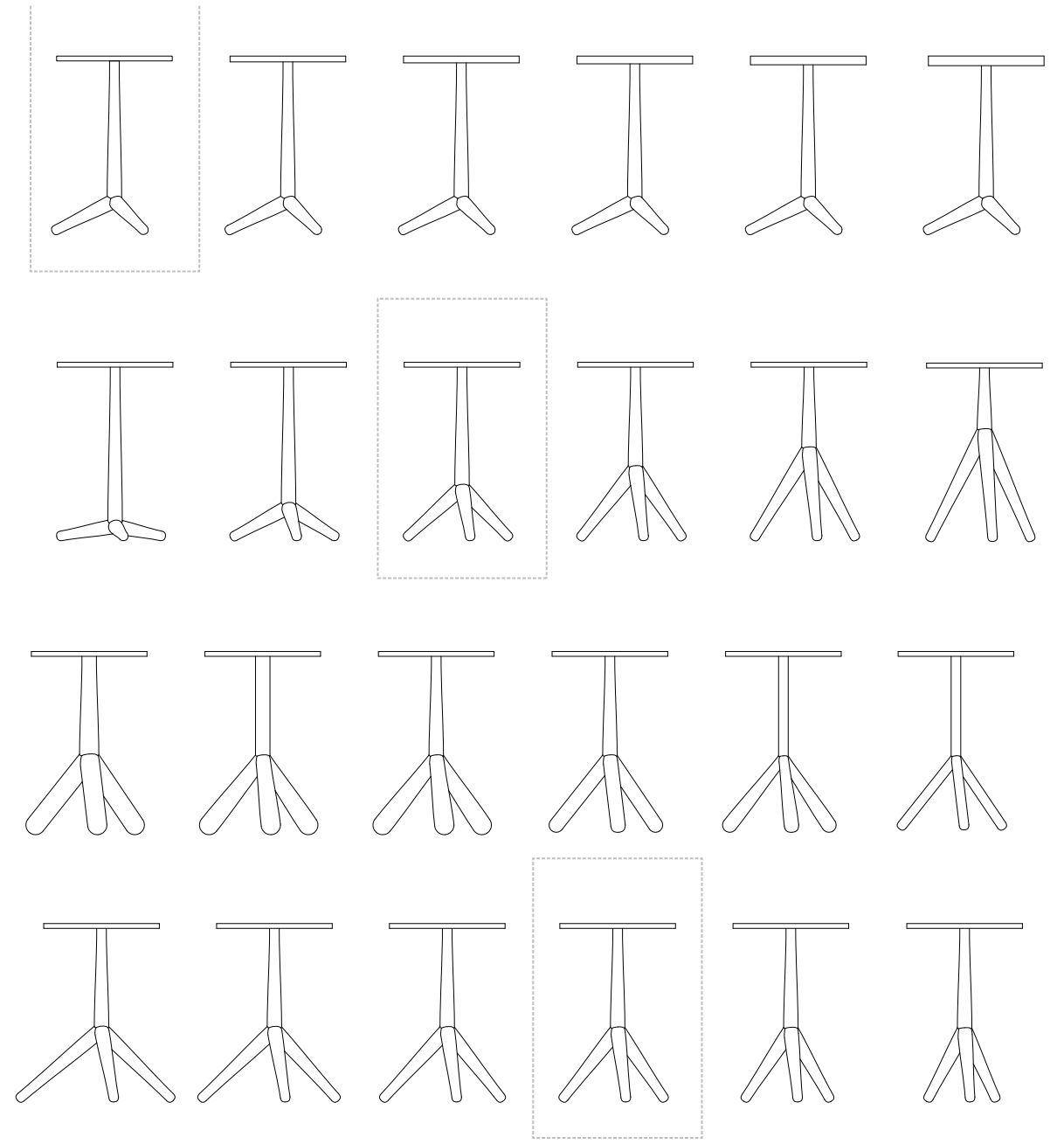

Parametric formal studies for seat thickness, leg spread distance, leg taper, center leg.



Gepetto | Ed. 50  
Cast Red Bronze | © Alex Willms



Private residence, Los Angeles, CA  
© STACKLAB

Geppetto with custom Blue Patina 16/50  
Private residence, Toronto, ON | © Denizens of Design



# Jupiter Collection

The Jupiter Collection showcases a versatile selection of coffee, side and dining tables, desks, and consoles. At its core is STACKLAB's signature solid cast metal Jupiter leg, seamlessly paired with materials such as cast acrylic, glass, domestic hardwood, plated steel and, in some cases, natural stone.

Building upon STACKLAB's commitment to digital prototyping, the Jupiter Collection brings a fresh dimension by infusing musical analysis into furniture design. It enhances the digital prototyping strategies pioneered in STACKLAB's Wishbone Case Study, which prioritized elements like strength-to-weight ratios and manufacturability. Named after Mozart's final symphony, the Jupiter Collection pays homage to the piece's expressive and compositional contrasts, reflecting the preference of the client who commissioned the first table.

The Jupiter leg geometry is a testament to asymmetrical design that maintains visual harmony. Its unique design is optimized for casting, ensuring distinct variations across all perspectives – elevation, section, and plan view.

Embracing Canada's rich manufacturing lineage, the Jupiter castings are sand-cast, a process typically reserved for heavy industry. This method imparts refined imperfections, heightening the tactile allure of each piece.



Jupiter Collection  
© STACKLAB



Jupiter Coffee Table  
© Douglas Friedman for Galerie Magazine  
Una Casa Privada, Los Angeles CA



Jupiter Coffee Table (Oval)  
Up to 48" W x 48" D x 16" H  
Acrylic and Cast Bronze  
© Alex Willms

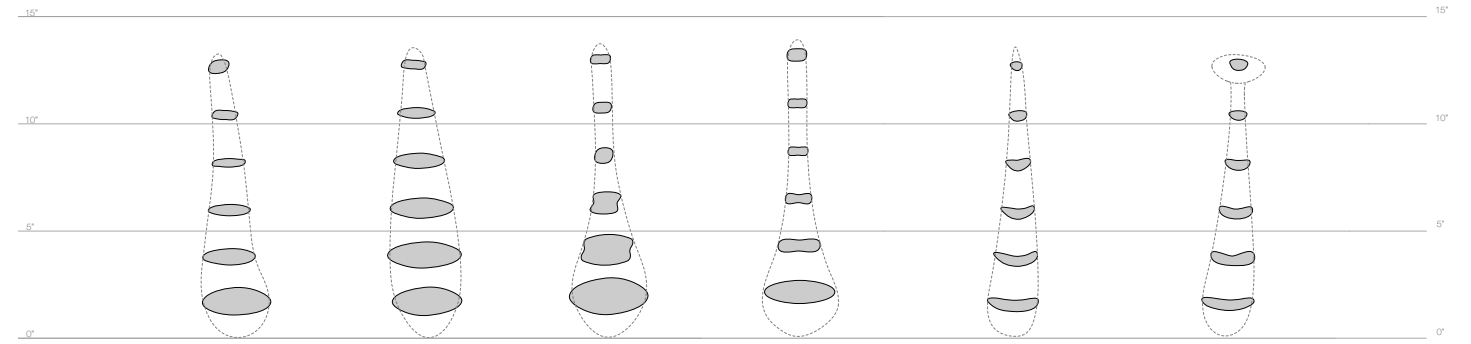

Jupiter Coffee Table (Oval)  
Up to 48" W x 48" D x 16" H  
Acrylic and Cast Bronze  
© Alex Willms

Jupiter Coffee Table (Rectangle)  
Up to 40" W x 40" D x 16" H  
Cast Glass and Cast Bronze  
© STACKLAB



Jupiter Coffee Table (Rectangle)  
Up to 48" W x 48" D x 16" H  
Acrylic and Cast Bronze  
© Roger Davies for Legaspi Courts Design



Jupiter Console  
© Alex Willms



Jupiter Dining Table  
Cast Bronze and Oxidized Oak  
© Patrick Biller

Jupiter Side Table  
Cast Acrylic and Cast Bronze  
© Patrick Biller



Jupiter Dining Table  
Cast Bronze and Oxidized Oak  
© STACKLAB



Jupiter Desk  
© Alex Willms

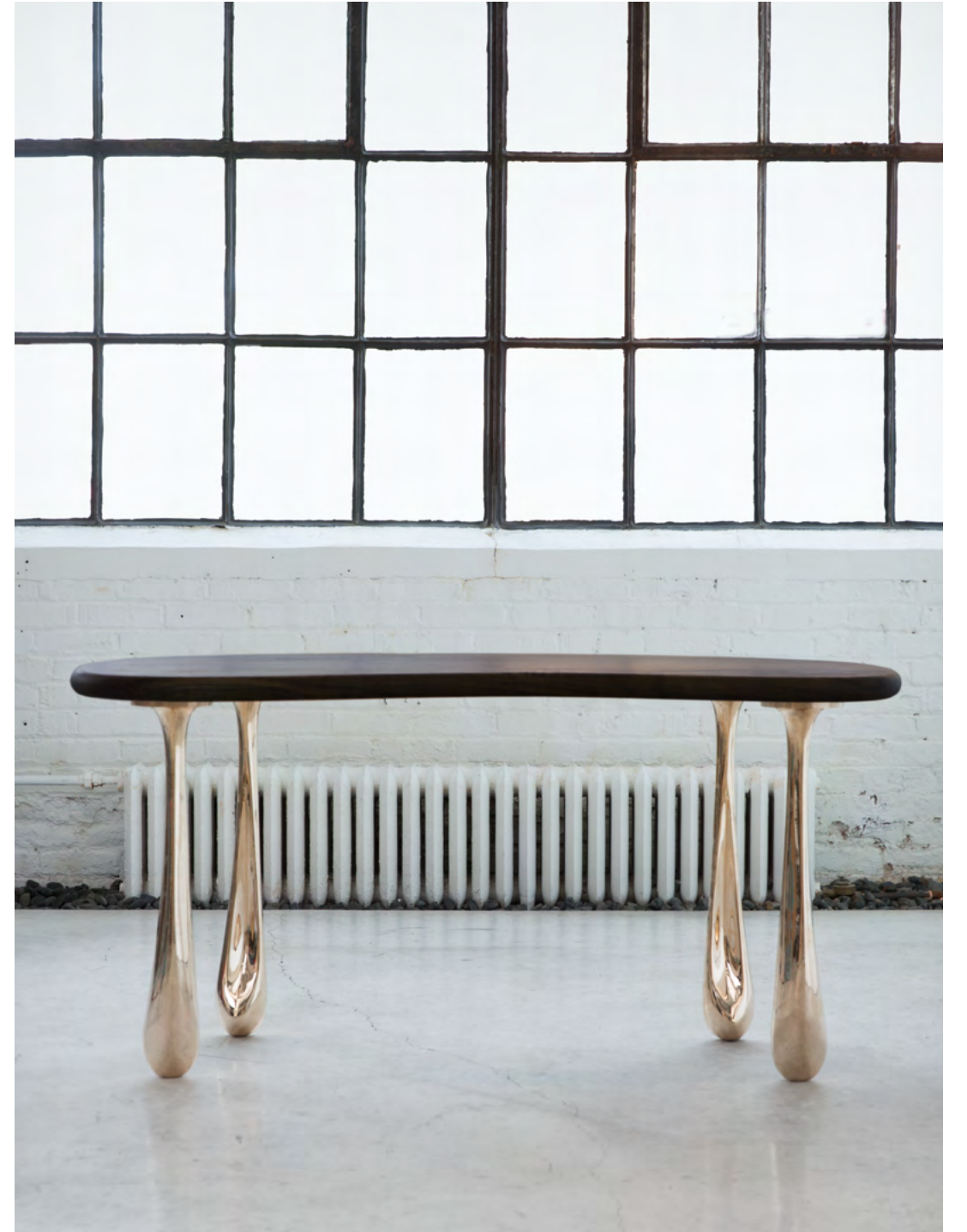

Jupiter Desk  
Cast Bronze and Black Walnut  
© Sean McBride

## Mura Collection

Developed in collaboration with The Goodman Studio (TGS), for partnering gallery Maison Gerard, The Mura Collection showcases coffee and side table designs. These designs merge STACKLAB's distinctive sand-cast metal Jupiter legs with a kiln-fused, droplet-shaped glass top. "Mura," stemming from the Japanese word for "unevenness," aptly describes the unique shapes of the tops and legs in every dimension.

TGS utilizes a specialized glass fabrication technique, where borosilicate glass rods are broken and their fragments are arranged in a kiln bed. This process results in a random pattern. After a week of firing and cooling, the glass emerges with a unique mottled appearance, characterized by milky translucent patches and clear windows. The slab is subsequently cut using a water jet and polished to perfection.

Owing to its artisanal craftsmanship, each Mura tabletop undergoes a meticulous three-week carving and polishing procedure, ensuring that every table is a one-of-a-kind masterpiece.



48" W x 48" D x 14" H  
Kiln-Fused Glass and Cast Solid Bronze  
© Rajeshta Julatum

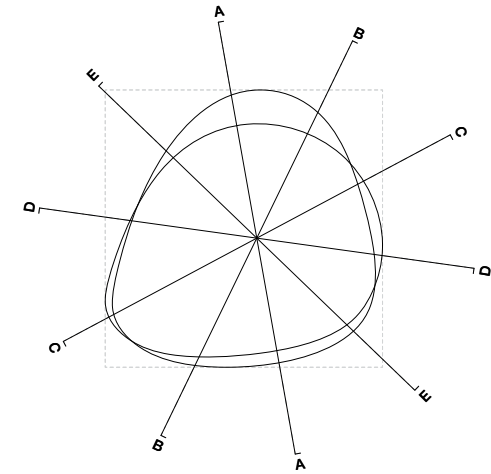

Section AA

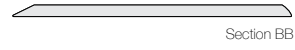

Section BB



Section CC

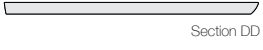

Section DD



Section EE





Mura Side Table  
© Patrick Biller for South Hill Home



Mura Side Table  
Kiln-Fused Glass and Cast Solid Bronze  
© Patrick Biller



# Wishbone Collection

In architecture, established benchmarks guide material choices and assembly methods, but the furniture industry lacks similar standards. This gap often results in extensive – and frequently wasteful – physical prototyping, particularly when multiple design iterations are needed.

The Wishbone Collection was created to address this challenge. Developed through a strategic case study by STACKLAB, it set out to establish structural and ergonomic benchmarks for dining tables, minimize physical prototyping through digital design, and leverage local manufacturing expertise.

At the heart of the collection is the signature cast metal leg, a triumph of parametric design and engineering. A custom algorithm generated over 1,000 forms, which were assessed using rigorous criteria and advanced tools such as Finite Element Analysis (FEA). The result is an optimized leg ready for large-scale production.

The collection includes console and dining tables, a vanity, and a desk. Each piece pairs beautifully rendered tops – crafted from stone, Engineered Cementitious Composite (ECC), domestic hardwood, or milled cast solid metals – with the distinctive Wishbone leg, available in aluminum or bronze. Honoring central-eastern Canada's industrial heritage, the legs are sand-cast, producing subtle, unique irregularities that enhance their tactile appeal.

The Wishbone Case Study has become a landmark project for STACKLAB, establishing a foundation for ongoing research into waste-reducing manufacturing processes.



Wishbone Collection  
© STACKLAB

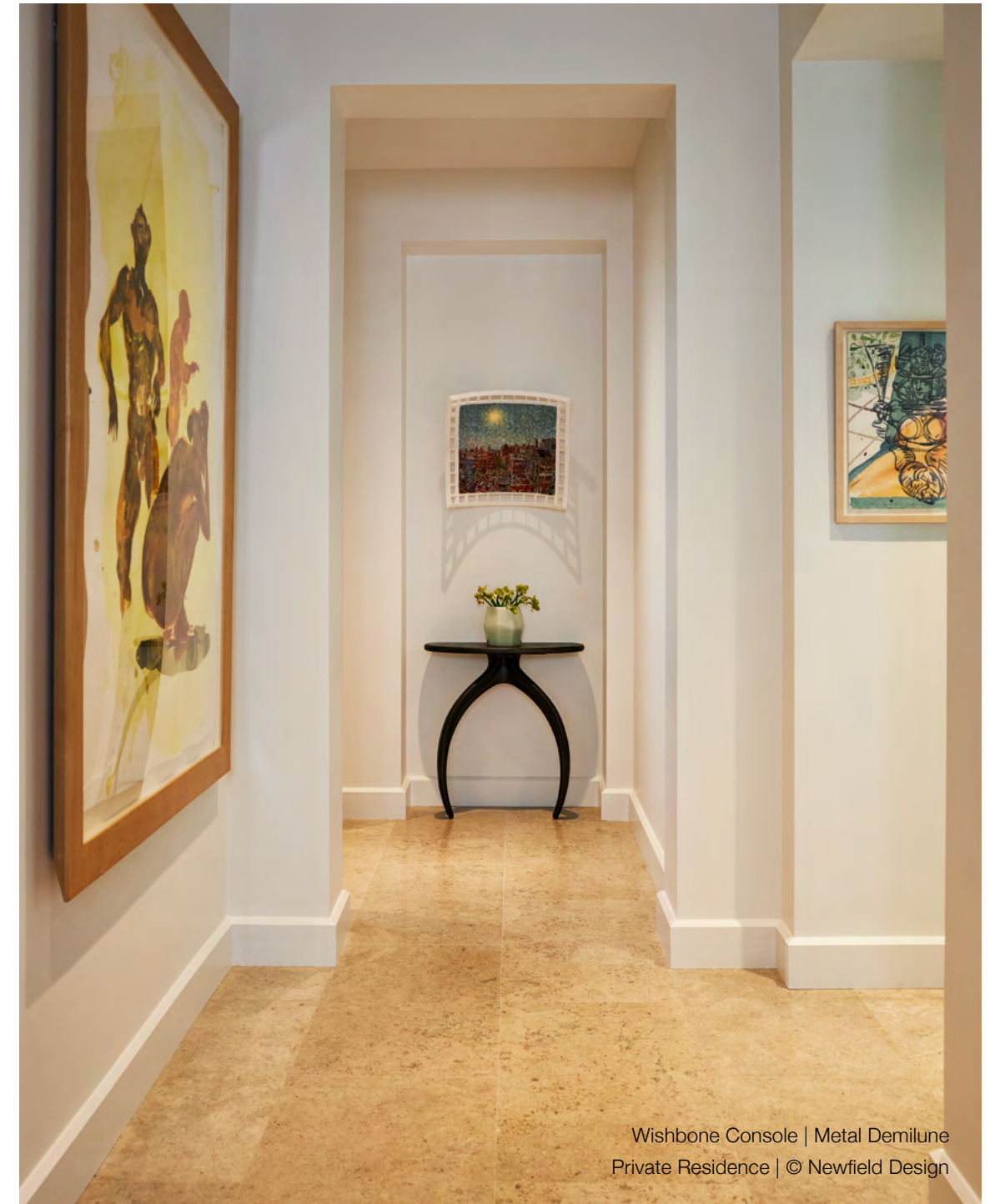
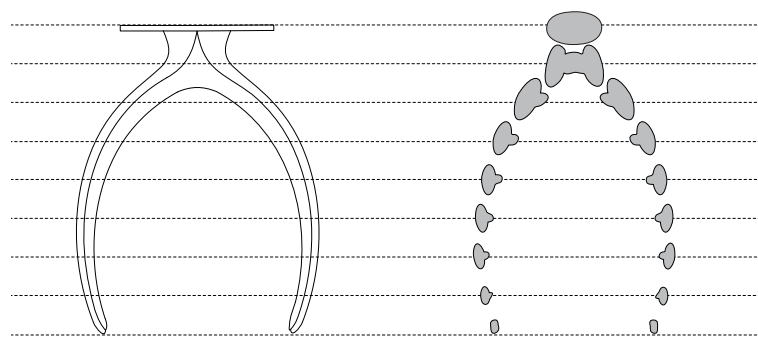

Wishbone Console | Metal Demilune  
Private Residence | © Newfield Design



Wishbone Console | Demilune  
Private Residence | © Patrick Biller

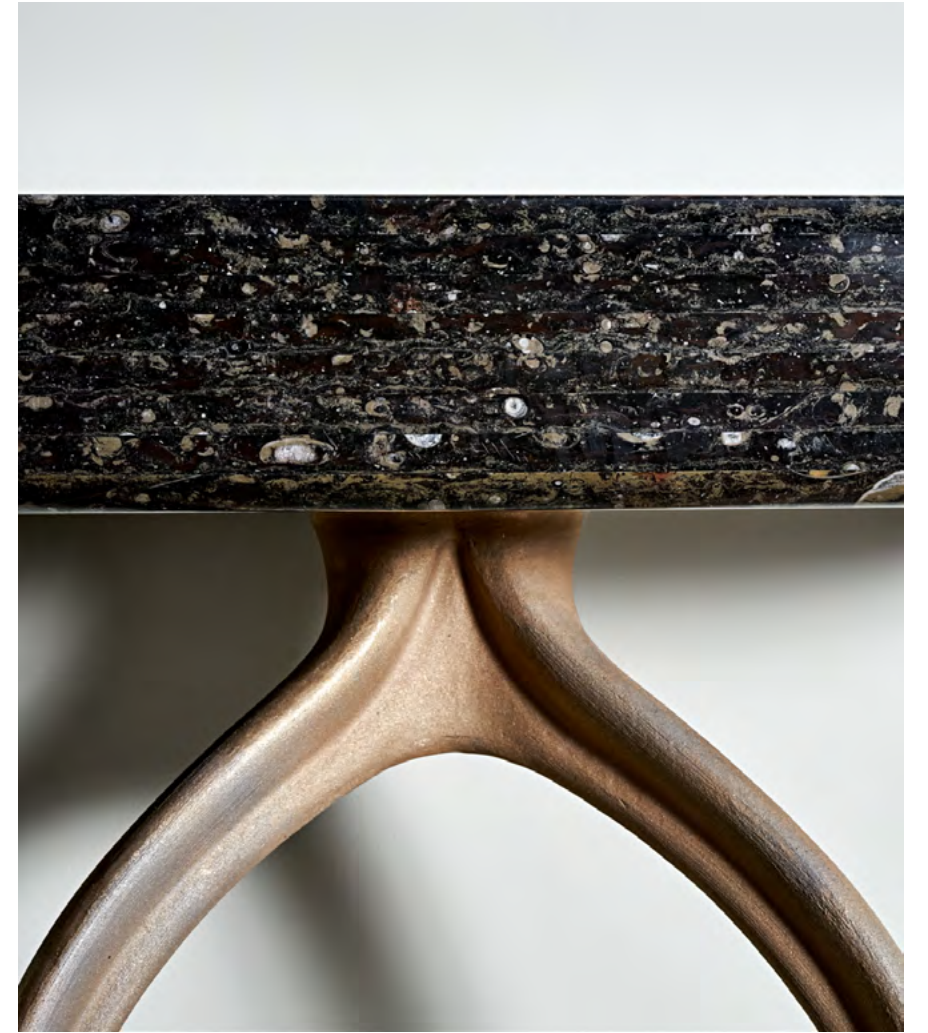

Wishbone Console | Demilune  
Cast Bronze and Stone  
© Patrick Biller



Wishbone Console | Demilune  
Cast Iron and Wood  
© Patrick Biller for South Hill Home

Wishbone Collection | Dining Table  
ECC, Cast Bronze  
Private Residence, Park City, UT | © Bryan Bilczewski



Wishbone Dining Table Commission  
Cast Bronze and Wood  
© Patrick Biller for Una Malan



# Audiofile

Audiofile is a privately commissioned console and Chihuly glass sculpture display. Featuring a 40-foot continuous band of patinated bronze, this wall-mounted assembly also provides storage for a cherished vinyl collection and incorporates a single, movable shelf suited for a turntable.



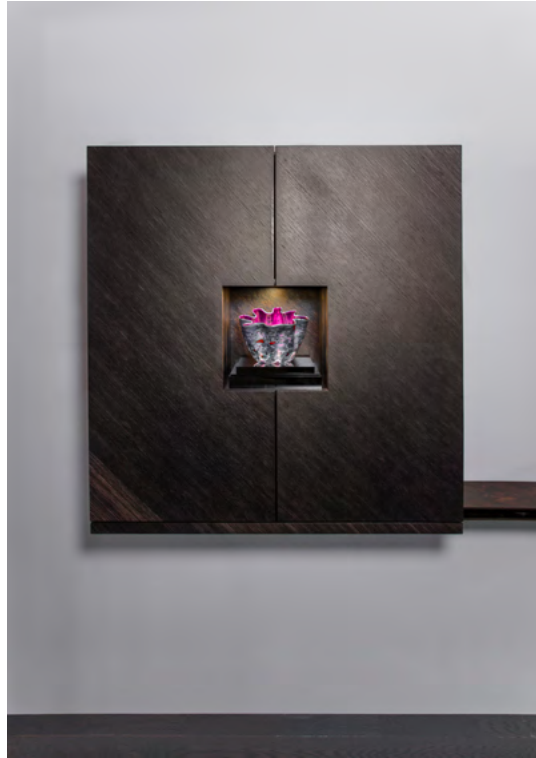

AUDIOFILE

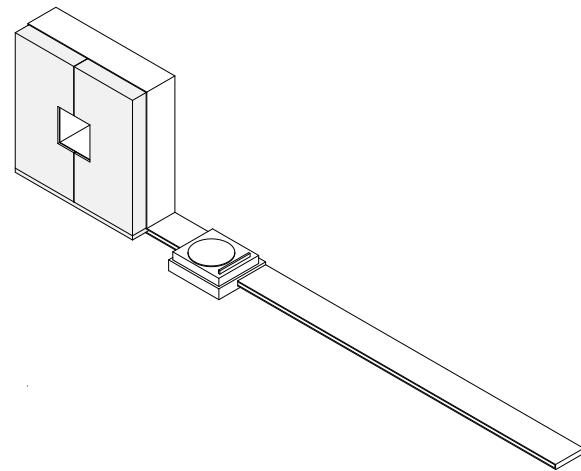

OXIDIZED OAK  
PATINATED BRONZE

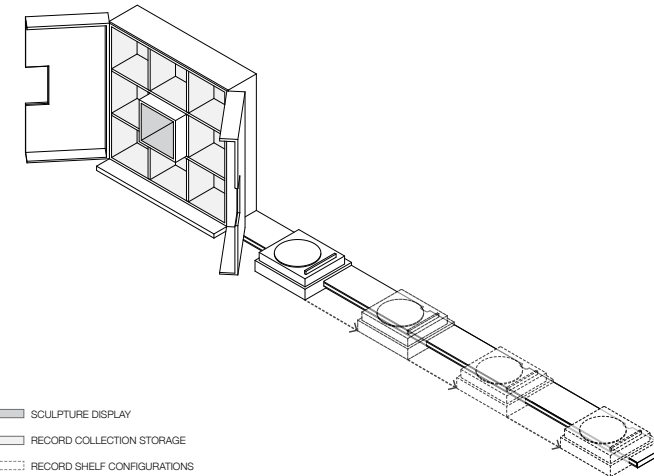

SCULPTURE DISPLAY  
RECORD COLLECTION STORAGE  
RECORD SHELF CONFIGURATIONS

189" W x 14-1/2" D x 42" H  
Oxidized White Oak and Cast Bronze with Patina  
© Sean McBride

## Ovoid | Dining Table

The Ovoid is a custom 10' x 5' asymmetric table, composed of old-growth Californian walnut and cast resin. The tabletop is paired with two blackened steel band ribbon legs, and a solid walnut pedestal.

The Ovoid marks an evolution of the material and design languages of STACKLAB's celebrated Cut Burl Series. Using the original perfected fabrication methods, the studio explored new formal possibilities and added premium domestic hardwood options to the series palette.

Commissioned by Frampton Co, New York.



Private Residence  
© Joshua McHugh for  
Frampton Co.



60" W x 120" D x 29 1/2" H  
California Black Walnut,  
Cast-Resin, Blackened Steel  
© STACKLAB

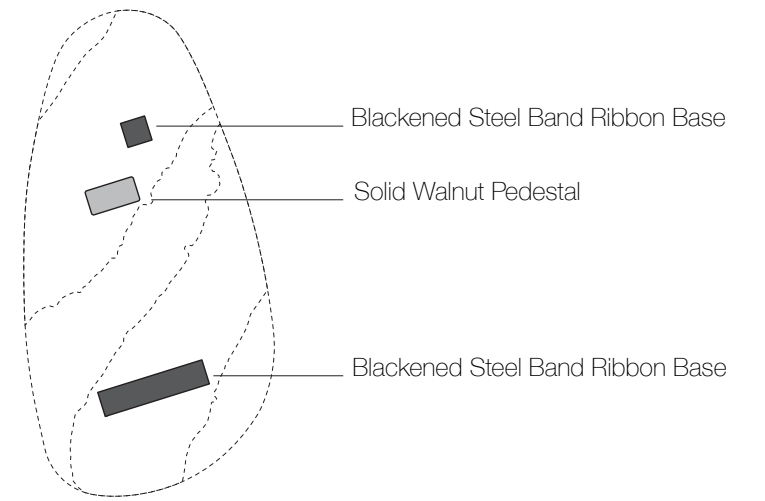

## The Selby

25 Selby Street is a new residential development in Toronto's east end, incorporating the 1882 Victorian mansion built for the founder of the Gooderham and Worts Distillery. STACKLAB assisted Johnson Chou Design in the development of a commissioned 25-foot long LED lighting fixture. A material homage to the stills once used in the production of spirits, the fixture features 20 sheets of mirror polished, laser cut, solid 22 gauge copper riveted to a ribbed aluminum frame.



Main Lobby | The Selby Apartments  
Toronto, Canada  
© Rajeshta Julatum

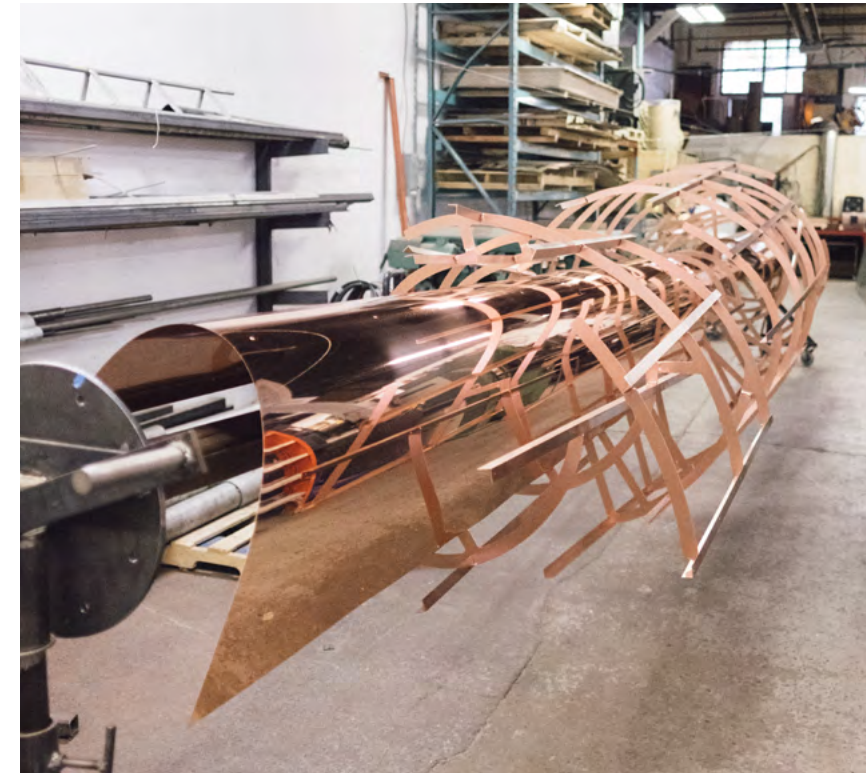
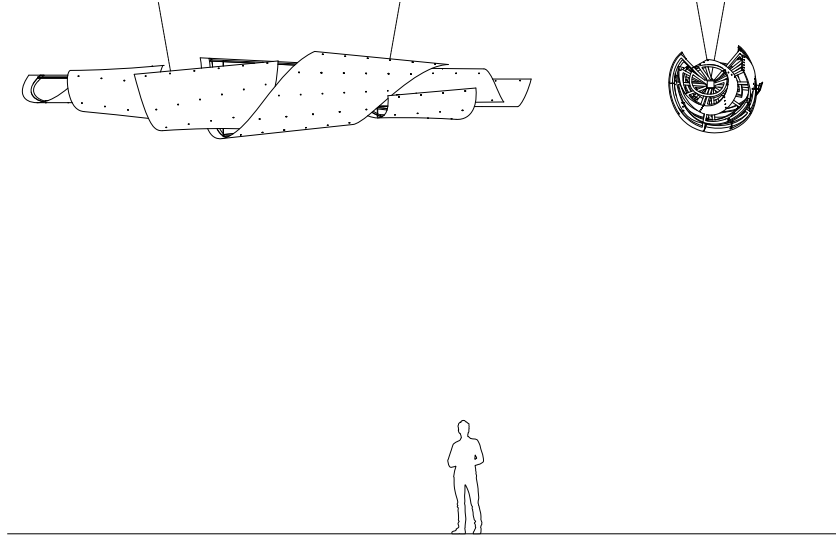

# Awards, Fairs & Exhibitions

## Recent Awards

### FURNITURE

#### Ash A356.0

Design by Nature Sustainable Design Award -  
Winner: Ash A356.0 Series  
- Design by Nature, October 2014, Toronto, ON

#### Cube Series

Design by Nature Sustainable Design Award -  
Winner: The Cube Series.  
- Design by Nature, October 2013, Toronto, ON

#### Felt Series

Best of Canada Award – Winner: Product Design: The Felt Series  
- Canadian Interiors, December 2020  
Toronto, ON  
Best of Year Award – Honoree: The Felt Series  
- Interior Design Magazine, November 30, 2018,  
New York, USA

#### Garrison 1-102

Best of Canada Award – Winner: Product Category  
- Canadian Interiors, November 2016, Toronto, Canada  
Design Innovation Award - Winner: The Garrison  
- ASID American Society of Interior Designers,  
April 2016, Minneapolis, MN USA  
Restaurant & Bar Product Design Award – Winner:  
Stools and Benches, June 2016, London, UK

## The Selby

ARIDO Award - Winner: Craft Category  
- ARIDO, October 2021, Canada

### INSTALLATION + ARCHITECTURE

AZ Award - Winner: Lighting installations. stackt | Tyvek  
Lighting - Azure, September 2020, Toronto, Canada

AZ Award - People's Choice: Lighting installations. stackt |  
Tyvek Lighting - Azure, September 2020, Toronto, Canada

Best of Canada Award - Winner: Project Category | Bezier  
Concertina - Canadian Interiors, November 2017, Toronto,  
Canada

Cannes Bronze Lion - Winner: Cyber Category. UBER You  
Drink, We Drive Campaign - Cannes Lion, June 2015,  
London, UK

## Fairs and Exhibitions

### FURNITURE

#### Brain 5.3

The Brain Project, 1st Canadian Place Gallery, Toronto,  
Canada, June - August 2016

#### Cube Series

Galerie House of Art and Design, New York, USA August 5-29,  
2021 – Via Maison Gerard  
Faust x Nike, 21 Mercer Street, New York, USA August 27 -  
September 31, 2022 – Via Maison Gerard  
Isola Design District, “Digital Platform,” Milan, Italy, June 16-  
21, 2020  
Kips Bay Show House, New York, USA May 2 - June 1, 2017 –  
Via Dineen Architecture  
The European Fine Art Foundation TEFAF, New York, USA  
May 4-8, 2018 – Via Maison Gerard  
The Holiday House New York City, New York, USA October 23  
- December 2, 2018 – Via Robin Kramer Garden Design  
The Salon Art + Design, New York, USA November 10-14,  
2016 – Via Maison Gerard

#### Felt Collection

Design Miami, Miami, Florida, November 30 – December 4,  
2022 – Via Mindy Solomon Gallery  
DesignTO, Toronto, Ontario, January 22 - 31, 2021  
Dutch Design Week, Eindhoven, Netherlands, October 17-25,  
2020 – Via Isola Design District  
IDS West, Vancouver, British Columbia, October 2020 - April

2021 – Via Alpenglow Projects  
Kips Bay Show House, Dallas, Texas, September 24 - October  
24, 2021  
Isola Design District, “Digital Platform,” Milan, Italy, June 16-  
21, 2020  
Milan Design Week, Milan, Italy, June 16-21, 2020 – Via Isola  
Design District

#### Garrison 1-51

The Collective Design Fair, New York, USA, May 5-8, 2016 –  
Via Maison Gerard  
The European Fine Art Foundation TEFAF, New York, USA,  
May 4-8, 2018 – Via Maison Gerard  
The International Exposition of Contemporary & Modern Art,  
Chicago, USA, September 13-17, 2017  
– Via Maison Gerard

#### Garrison 52-102

The Collective Design Fair, New York, USA, May 5-8, 2016 –  
Via Maison Gerard  
The European Fine Art Foundation TEFAF, New York, USA,  
May 4-8, 2018 – Via Maison Gerard  
The International Exposition of Contemporary & Modern Art,  
Chicago, USA, September 13-17, 2017  
– Via Maison Gerard

#### Garrison 103-133

The European Fine Art Foundation TEFAF, New York, USA  
May 4-8, 2018 – Via Maison Gerard  
Salon Art and Design Fair, New York, USA November 11-14,

# Permanent Collections, Publications, Press & Lectures

2021 – Via Maison Gerard

## **Mura Low Table**

Salon Art & Design, New York, USA, November 8-12, 2018 – Via Maison Gerard

## **Mura Side Table**

Galerie House of Art and Design, New York, USA August 5 - 29, 2021 – Via Maison Gerard  
Salon Art & Design, New York, USA, November 9-13, 2023 – Via Maison Gerard

## **Wishbone Series**

Toronto Offsite Design Festival, Toronto, Canada, January 2014 – Via Digital Promises

## **INSTALLATION + ARCHITECTURE**

### **Bezier Concertina**

Paris Fashion Week, Paris, France, February 2-31, 2017 – Via by Hotel Amastan, Paris

### **Happiness by Design**

New Era, Toronto, Canada, 2017 – Via Vice Canada and Motherboard

### **Razzle Dazzle**

MOVE, Ontario Association of Architects (OAA), Toronto, Canada, September 15-16, 2017

## **Sand + Draft**

Interior Design Show, Toronto, Canada, 2018 – Via AZURE  
Isola Design District “Digital Platform,” Milan, Italy, June 16-21, 2020

## **#Solo**

Une Exposition de Photographies, avec Elie Kimbembe, Toronto, Canada, March 23, 2019

## **Stackt | Tyvek Lighting**

Via Stackt Market, Toronto, Canada, 2019

## **Stackt | Forme Pavilion**

Via Stackt Market, Toronto, Canada, 2019  
Isola Design District, “Digital Platform, “ Milan, Italy, June 16-21, 2020

## **Wild Abode**

Expo for Design, Innovation and Technology (EDIT) Toronto, Canada, September 28 - October 8, 2017 – Via Great Gulf

## **Permanent Collections**

### **Garrison 52-102**

City of Toronto Permanent Fine Art Collection, Toronto, Canada, 2015  
Unit 100/102

Permanent Collection of the Embassy of Canada to Iceland in Reykjavik, 2016  
Units 63/102 and 68/102

## **Publications**

### **INSTALLATION + ARCHITECTURE**

#### **Bezier Concertina**

PUBLIKATION NEW MOVE feat. Bezier Concertina  
Institute for Building Design and Technology, Leibniz University Hanover School of Architecture  
Prof. Michael Schumacher, Birkhäuser Publishers, 2018

Detail Inside – “Selbsttragende Faltwand mit Präsentationsflächen (Self-supporting folding wall with presentation displays),” 2017

## **Select Press**

### **STUDIO**

Azure magazine – “O, Canada! 10 Canadian Designers Making it Big Abroad,” June 30, 2022  
Block Magazine – “Creativity Ignited,” Spring 2015  
Designlines – “How STACKLAB goes against the grain,” 2015  
Designlines – “Show Us Where You Live,” 2020  
Designer Inc – “StackLab: Designs That Are More Than Meets the Eye,” March 2018  
Distillery District Magazine – “A Lab of Many Traits,” Vol. 23, April 2018  
Embark – “A Rebel with A Cause,” June-July 2014  
Entrepreneur Podcast Network – “STACKLAB, a multi-disciplinary design studio with Jeff Forrest,” August 2014  
House Porn – “An Interview with Jeff Forrest, Toronto Designer & Founder of STACKLAB,” January 2021  
Studio Fenice – “Designer Jeffrey Forrest of STACKLAB on Solving Problems and Designing Systems,” May 2022  
Toronto Life – “8 Must-See Locations at Doors Open 2017,” May 2017

### **FURNITURE**

#### **Ash A356.0**

Azure – “Seven Great Furnishings Made with Recycled Wood,” November 2014  
Canadian Interiors – “How it’s made,” January 2015  
Globe Life & Arts – “Coveted: STACKLAB’s A356.0,” December 2014  
The Globe and Mail – “Charming stools, side tables beautifully

repurposed from ash logs, sawdust,” December 2014

### **Ash Collection**

Architectural Digest Mexico – “Piezas que aportan artesanía y diseño a cada rincón de la casa,” October 2022

Architectural Digest Mexico – “Pieces that bring craftsmanship and design to every corner of the house,” April 3, 2022

Business of Home – “Buzzworthy debuts from The Future Perfect, Brigitte Romanek’s first furniture collaboration, and more,” September 2021

Canadian Interiors – “STACKLAB continues to explore systems-based design with an expanded Ash Collection,” July 2021

Interior Design – “Bold & bubbly – fall market tabloid,” October 31, 2021

### **Cube Series**

Architectural Digest – “Brad Ford Outfits New York’s Largest Living Room,” 2018

Interior Design Magazine Spring Market Tabloid – “Smoking hot! Spring Market Tabloid,” 2017

Interior Design Spring Market Tabloid – “Shapeshifters: Freedom products that break the mold,” May 2017

Interior Design Magazine Spring Market Tabloid – “Market Live 2018 Product Highlights,” May 2018

Luxe Interiors & Design – “Mix, Match And Covet These Chic Pieces That Go Better Together,” May 2021

Torontoist – “Salvaged Materials Make Surprisingly Nice Furniture at Design by Nature,” August 2013

### **Cut Burl Series**

Elle Decor – “House Tour: A New York Apartment with Dramatic Flair,” September 2015

Galerie – “Burl Wood is Having a Major Design Movement,” August 2020

### **Felt Collection**

Agencia EFE – “Residuos con vida alargada y tecnología, la apuesta de Jeff Forrest,” November 30, 2022

AGO Insider – “Design, distanced and virtual,” January 20, 2021

Artribune – “Milano Design City: Program of the Autumn Fuorisalone,” September 23, 2020

At Home Victoria – “Introducing the Felt Collection,” October 2020

Azure Magazine – “Holiday 2018: Gifts for Designers,” November 2018

Canadian Architect – “2020 Holiday Gift Guide,” October 2020

Canadian Interiors – “Feelin’ Good,” November 2018

Designlines – “How STACKLAB’s Felt Series Disrupts the Design Process,” March 2020

Designlines – “The Sights to See (From a Safe Distance) at DesignTO,” January 2021

Design Milk – “Discover Milan’s Isola District Virtually with Isola Goes Digital,” June 2020

EcoLux Lifestyle – “View STACKLAB’s algorithm-inspired ‘FELT’ only in Vancouver,” October 2020

Elle Decor Netherlands – “No Salon del Mobile this year, so you will not miss anything of the latest design,” June 2020

Gray Magazine – “For Design, By Design at Alpenglow

Projects,” October 10, 2020

Hunker – “STACKLAB Turns Scraps into High-End Pieces,” November 2020

Ideas y Tendencias Interiores – “Pensar en el Cambio,” August 2020

Interior Design – “Milan’s Isola Design District goes Completely Virtual with Interactive Online Neighborhood,” June 2020

Interiores – “Pensar en el Cambio,” August 2020

Mad White – “MEBLE Z ODPADÓW PRZEMYSŁOWYCH. STACKLAB UŻYŁ ZALEGAJĄCEGO FILCU,” November 2023

Mansion Global – “Bringing Hygge into Your Home,” November 2018

VitaDaily – “6 Home Items to Hygge Your Space During Lockdown,” December 2020

### **Garrison 1-102**

Azure – “Natural Perch,” 2016

Canadian Interiors – “Reclaimed Steel from Demolished Bridge Cast into Limited-Edition Design Object,” 2016

Canadian Interiors – “Best of Canada,” September 2016

Domino Magazine – “In Pursuit of Beauty,” March 2019

Interior Design Magazine – “Objets d’art,” 2016

Interior Design Magazine – “Nine sculptural seats that double as art,” January 2017

Modern Luxury Dallas – “The Right Stuff,” January/February 2019

National Post – “Salvaged Bridge Rebar from Toronto’s Historic Fort York Upcycled into Furniture Piece,” January 2016

Notable – “The Garrison: You Can Now Have a Piece of Toronto’s History in Your Living Room,” January 2016  
Montreal Gazette – “Historic Fort York Upcycled into Furniture Piece,” 2016

The Globe and Mail – “Dual Stool-Table Built with Salvaged Materials from Historic Toronto Bridge,” 2016

The Toronto Star – “Own a Piece of the 6,” 2016

### **McDonald’s Boombox**

Designboom – “McDonald’s Metamorphoses Cup Holder into Recyclable Boombox,” July 2017

Inc. – “McDonald’s Just Did Something Brilliant to its Drink Trays That Can Never Be Undone,” July 2017

Strategy Magazine – “Utility in Small Packaging,” April 2018

### **Mura**

Architectural Digest – “This Penthouse Overlooks Central Park – But Feels Like It Could Be on a Scandinavian Archipelago,” April 8, 2024

Canadian Interiors – “STACKLAB and Jeff Goodman Studio launch Mura low table,” October 2018

Homecrux – “Mura Side Table by STACKLAB is Asymmetrical and Enigmatic,” April 2023

Luxe Interiors & Design – “Escape To This Color-Splashed Hamptons Abode For The Weekend,” July 2023

Interior Design Spring Market Tabloid – “Light and Lively,” May 2019

Trend Hunter – “The ‘Mura’ Side Table Has a Flowing Base Design,” April 2023

## **INSTALLATION + ARCHITECTURE**

**229**

House & Home – “True Blue,” April 2021

### **Bezier Concertina**

AMC archi.com – “Aménagement de papier pour popup store parisien,” December 2017

Azure – “This Paris Pop-Up Clothing Store is Built Entirely of Paper,” 2017

Canadian Interiors – “Best of Canada,” 2017

Detail – “Self-Supporting Folding Wall with Presentation

Displays,” 2017

### **Forme Pavilion**

Building Magazine – “Site Visit - New life at stackt market in Toronto, a critical design team transforms ubiquitous materials into unique new design,” February/March 2020

Canadian Interiors – “Cross Pollination: Embracing inspiration from alternative disciplines,” February 2020

DesignBoom – “STACKLAB sites community-focused, culture and retail hub at the heart of Toronto,” February 2020

The Globe and Mail – “Old shipping containers carry a new retail vision,” August 13, 2019

### **Greenhouse 1.0**

BlogTO – “Toronto Designer creates new greenhouse that could start popping up in city backyards,” August 2022

Contemporist.com – “The Shape of this Greenhouse is the Result of Keeping the Existing Footprint of a Pool,” August 2022

Designlines – “One Thing – Local studio STACKLAB crafts an easily replicated greenhouse prototype for tiny Toronto backyards,” September 2022

### **Happiness by Design**

Toyota Canada – “How two design teams combined to build happiness by design,” December 17, 2019

### **Richmond Station**

The Star – “Richmond Station review: Subway-themed restaurant opened by Top Chef Canada winner,” 2012

### **Sand + Draft**

Interior Design Magazine – “Eleven products that wowed at IDS [Interior Design Show],” 2018

### **Tyvek Lighting**

Azure – “AZ Awards 2020 Winner: Temporary Tyvek Lighting Installation at Stackt Market,” September 3, 2020

### **#Solo**

Canadian Interiors – “Solo - STACKLAB designs environment for Canadian photographer’s first gallery exhibit,” 2019

Interior Design – “STACKLAB Creates an Experiential IRL Installation for Instagram-Famous Photographer, Elie,” 2019

Society of British and International Interior Design (SBID) – “Exploring Themes of Discovery with an Immersive

Installation,” October 23, 2019

### **Wild Abode**

Canadian Interiors – “STACKLAB installation a finalist for SBID International Design Excellence Award,” September 2018

Canadian Interiors – “Caught our eye,” September 2017

Insight: Art of Living – “Bruce Mau’s Larger Than Life Design Career,” September 2018

Interior Design – “Shedding Light-Centerfold,” September 2018

Interior Design – “Community Agency and STACKLAB Think Green for Toronto’s Design Exchange Museum,” September 2018

Premier Construction – “Wild Abode, a pioneering project,” October 2018

## **Lectures & Panels**

Architecture and Design Film Festival (ADFF)

“Grethe Meyer - The Danish Porcelain Queen,”

TIFF Bell Lightbox, Toronto

November 5, 2022 Via Toronto Society of Architects (TSA)

Designer Inc.

Fall Market communications week

In conversation with Jeff Forrest, Founder – STACKLAB

October 2021 - Virtual Event

Good Future Design Alliance

Confab ‘24 | Green Design Visionaries

“The Modern Philosophy of Furniture Design,” with STACKLAB/Stackabl, Model No., and Prowl Studio

Moderated by David Charne of Fyrn

Fort Mason Center for Arts & Culture, San Francisco

September 12, 2024

Industrial Designers Society of America

“Design Circularity: Sustainable Futures Through Design Innovation,” with STACKLAB/Stackabl, PlsReturnIt, Lot21, and Belworld Creative Inc.

Moderated by Surya Vanka, Founder, Authentic Design, Chair-Elect, IDSA

Mingei Theatre, San Diego

September 20, 2024

Interior Design Show Toronto

“Circular Economy: The Three Rs at Work,” with STACKLAB, Denizens of Design, and Unbuilders. Moderated by Dr. Soren Brothers of the ROM.

January 20, 2023

Interdisciplinary Cross Pollination – Stack Based Design and Panel, December 5, 2019

Toronto Metro Convention Centre

Using Urban Wood Forum Urban Material Reclamation, January 17, 2017

Toronto City Hall, Canada Green Building Council

10x20x20 - The Garrison, September 16, 2016

Winnipeg Art Gallery

CraftED, Manitoba Crafts Council

The Stack | Technology and Regionalism in Design Design Chicago October 27, 2021

2026

# FURNITURE

STACKLAB

[stacklab.ca](http://stacklab.ca) | [@stacklab\\_design](https://www.instagram.com/stacklab_design)