

HL79xx Low Power Mode Measurement

TECHNICAL NOTE

This document provides guidance in using OTII ARC to measure the HL7900 hibernate current consumption with a CMW500.

Introduction

This document is provided to Semtech distributors and clients to aid more rapid development of embedded applications using the Semtech portfolio of cellular solutions. To request a new technical note, contact your regional Semtech Product Marketing Manager.

- [Document History](#)
- [Important Notice](#)

Development Kit Setting for Low Power Mode Measurement

Semtech suggests to use the development kit to measure HL79xx in low power mode.

Development Kit (Blue) Setup

Removing and shorting jumpers will allow the board to be powered by the USB while allowing the module to be powered by an external source (e.g. the OTII). Refer to the following jumper settings:

- CN805 — Development Kit main power from UART0/1
- CN301 — Enables UART0 power
- CN401 — Enables UART1 power
- CN1301 (pins 1 and 2) – Enables module's power using external source only
- CN1308 and CN1309 — Disconnects isolating capacitors to power lines
- CN1310 — Disables DC Power from USB source
- SW203 — Turns off Wakeup switch
- CN1000 — GPIO13 is External Wake up

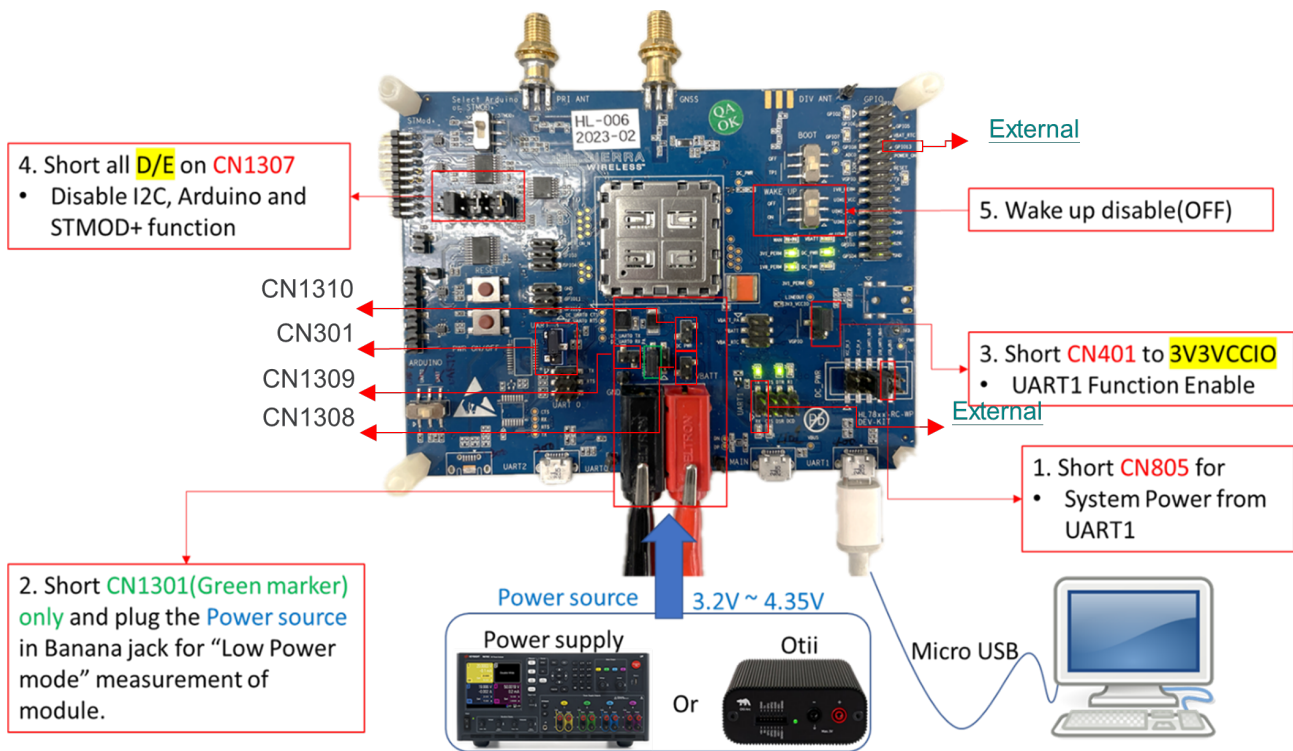

Figure 1: Setting Up the Development Kit (Blue HL78xx EVK)

The HL79xx and HL78xx share the same PIN defined in RING-C, excluding the USB function. Therefore, the development kit can accommodate HL79xx RING-C features such as GPIOs, RF, GPS, UART, ADC, etc. For support regarding the HL79xx RING-B function (JTAG, PSRAM, Dual-FLASH, etc.), see the HL7900 Product Technical Specification.

Note: Garbage characters may appear on the UART1 sometimes as it is a known issue on the HL7900 Development Kit. It is recommended to add a pull-up resistor (10K-100K Ω based on customer design) on UART1_Rx.

OTII Arc Setup

To set up the OTII ARC:

1. Connect 3.7V to a Banana Jack on the development kit.
2. Connect DGND to the GND on the development kit.
3. RX should be connected to the development kit UART1 RX if taking AT log is required. Otherwise, leave this disconnected.
4. GPO1 should be connected to the development kit if controlling the module's external WAKE_UP pin. Otherwise, leave this disconnected.

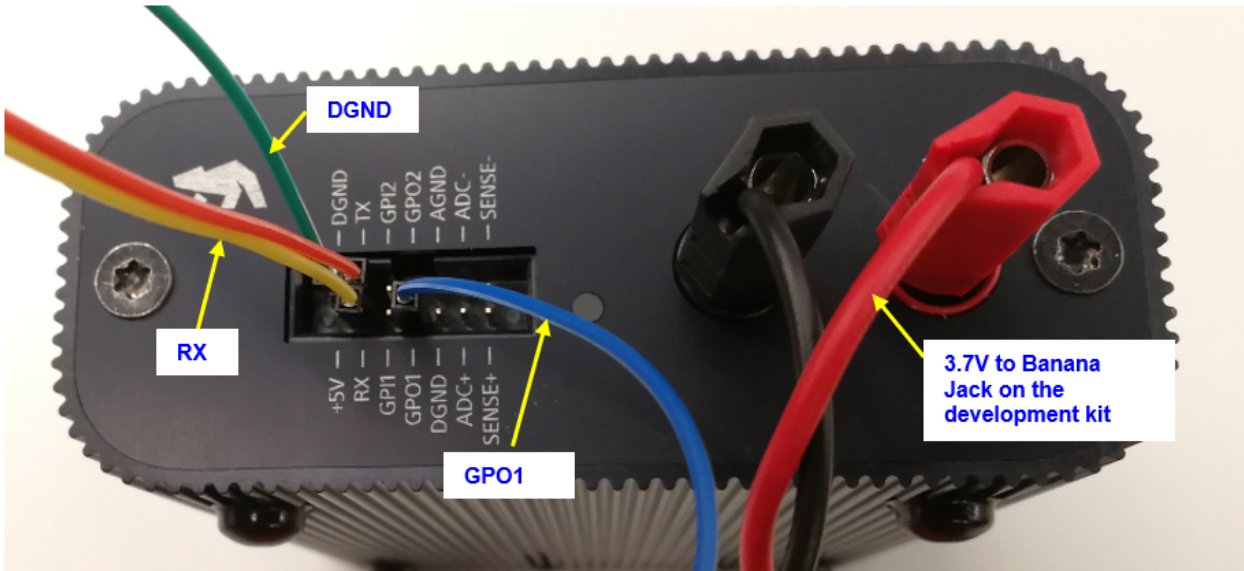

- 5. Connect the USB port to a computer. Use a PC USB port with a marking, if possible. This indicates high power and the port may provide up to 1.5A to your device. USB ports without this sign can normally provide only up to 500mA.

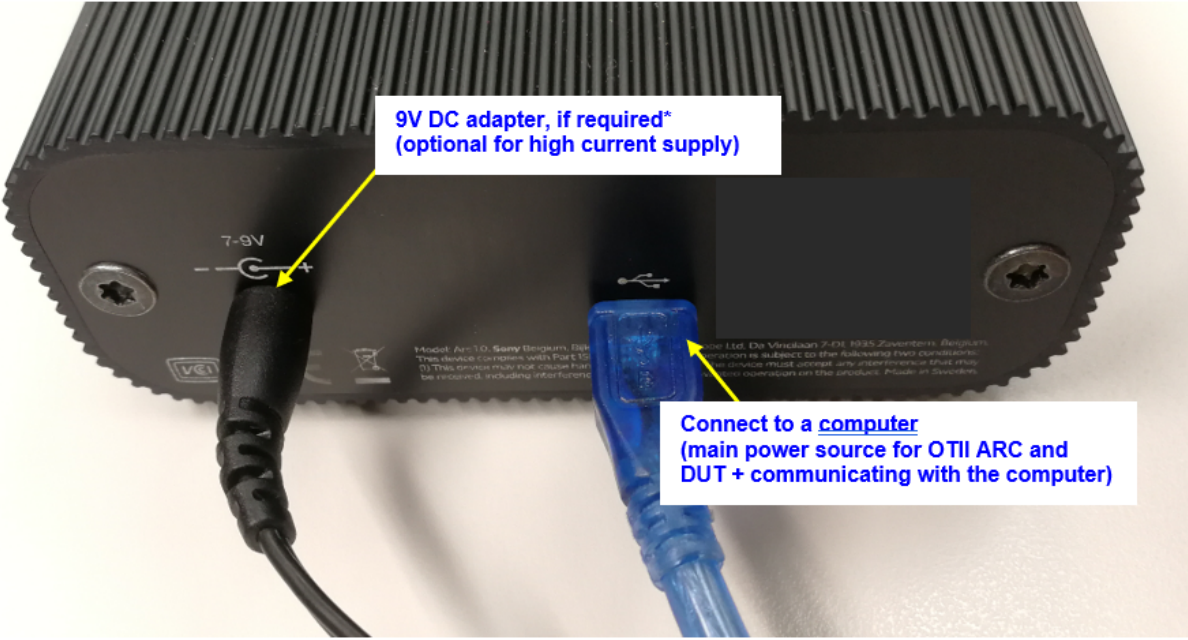

Note: If using an external DC adapter, it is recommended to pick one from an established supplier. The adapter should be low noise, approved for IEC 60950-1 as a Limited Power Source, and have an output of 9 VDC, 2.5 A.

6. From the OTII ARC window, click **Create a new Otii project**.

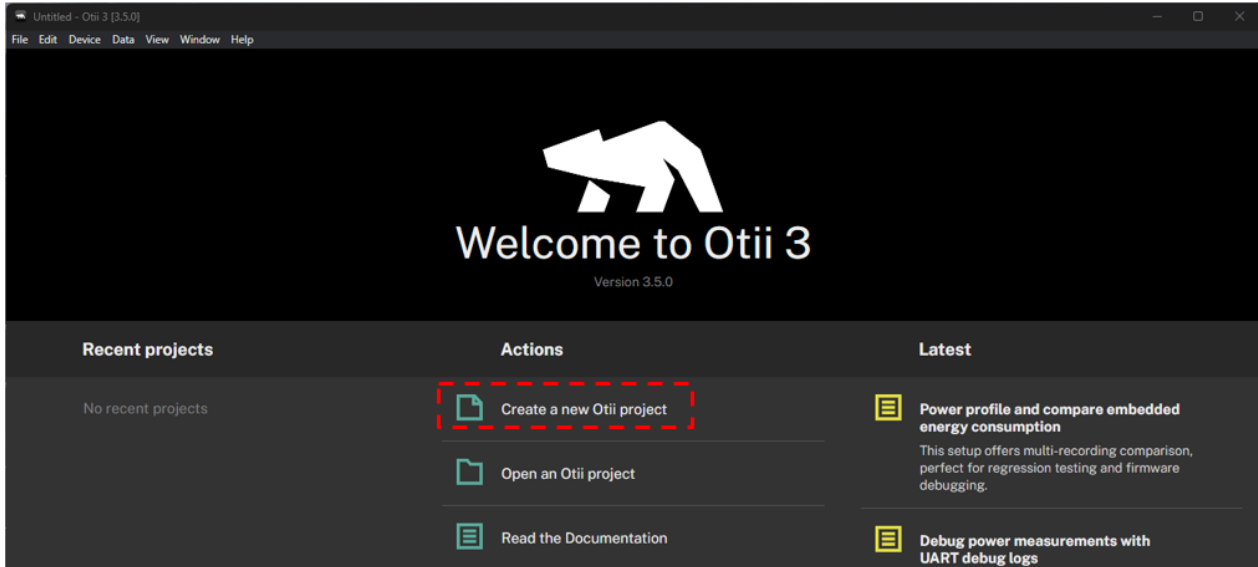

7. Click **Add** to open the Otii COM port.

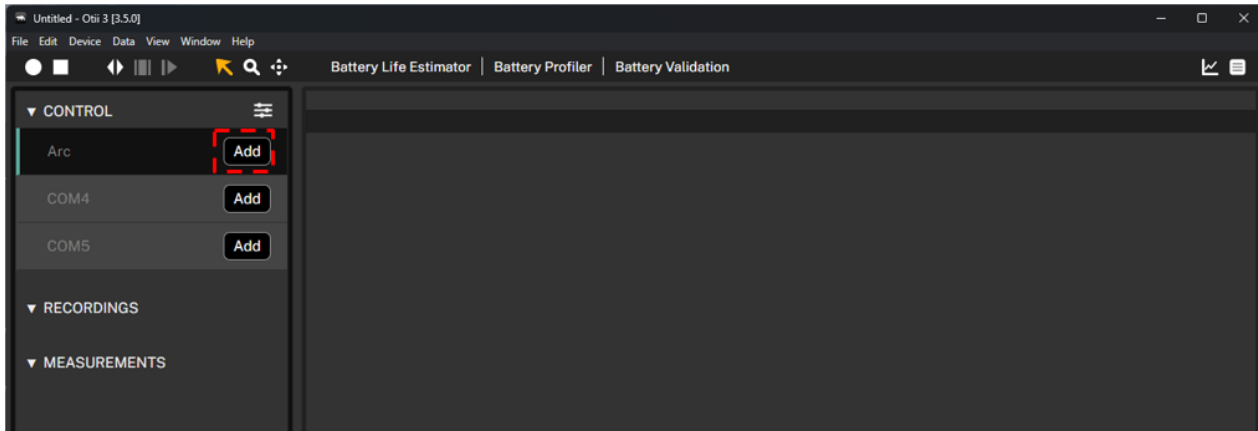

8. Specify the **Main voltage** and click **Main current** to specify measuring current. Click **UART log** if AT log is required.

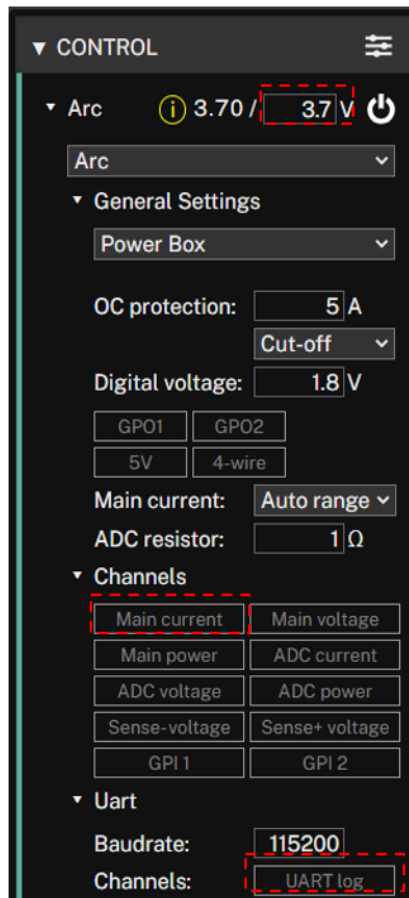

9. Start supplying the power by clicking power icon.

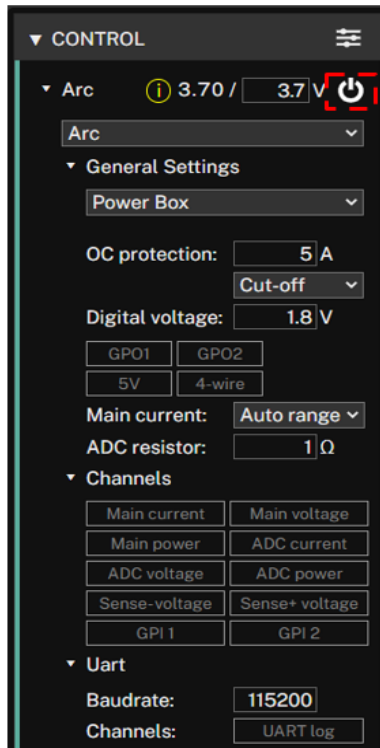

10. GPO1 controls the module's WAKE_UP pin.

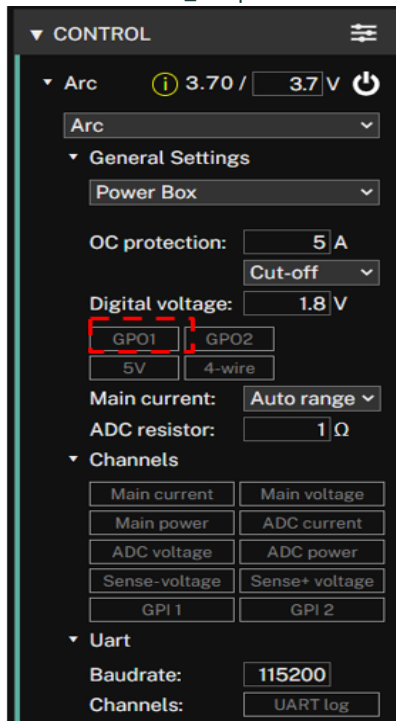

GPO1

Indicates low output

GPO1

Indicates high output

CMW500 Setup

CMW500 PSM Setup

Configure the CMW500 by clicking and setting up the items marked in the following screenshots.

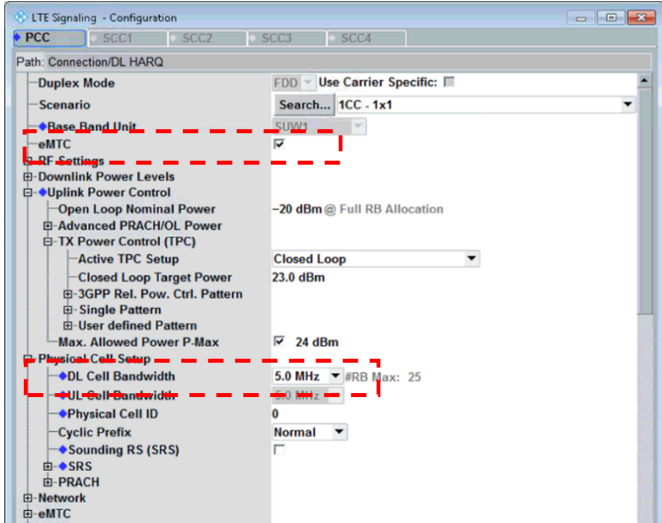
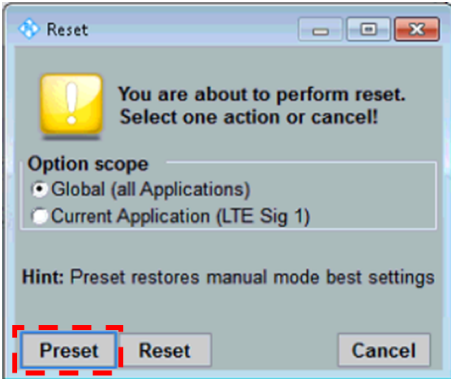

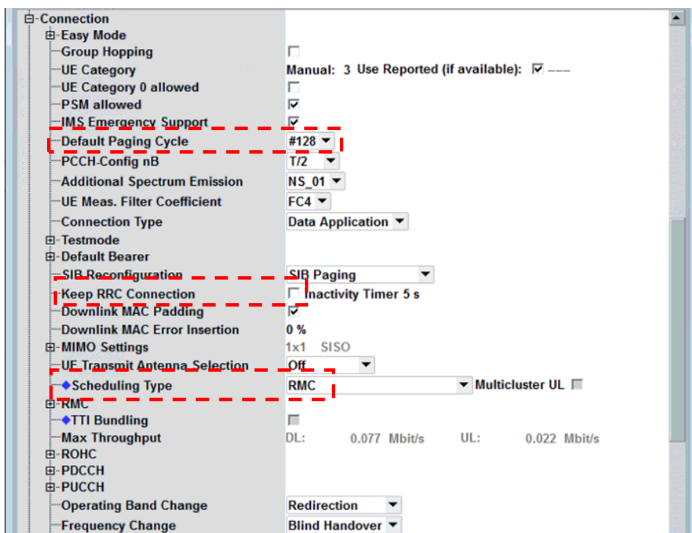
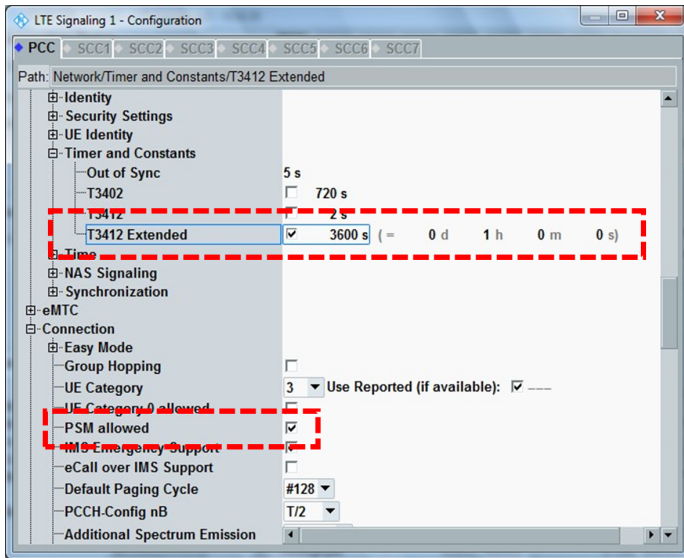

CMW500 eDRX Setup

Configure the CMW500 by clicking and setting up the items marked in the following screenshots.

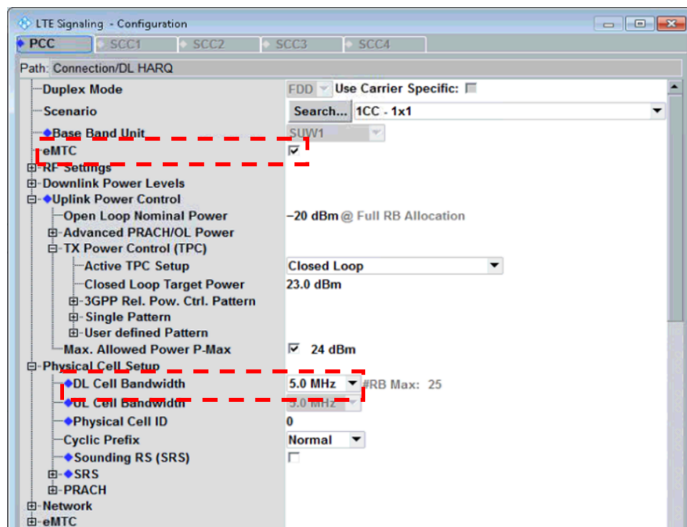
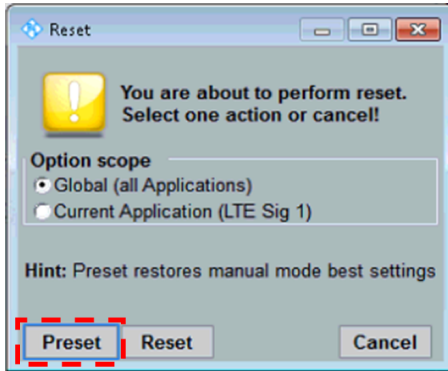

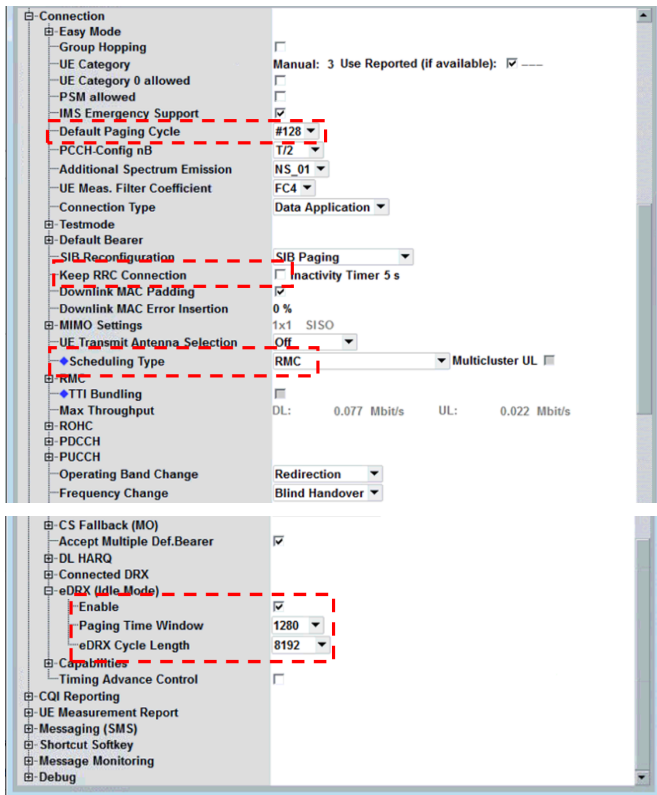

AT Commands Setup

eDRX

Use the following AT commands to set up the eDRX.

1. Check SIM deactivate.

at+crsm=176,28589,0,0,4
+CRSM: 144,0,"81000802"
 //SIM card should support "UICC deactivated during eDRX". This option is indicated in values 1 and 8 marked in red.
OK
2. Select Cat-M1. — Select Cat-M1 as the LTE category. This command needs a reboot.
AT%RATIMGSEL=1
3. Select Band — Select Cat-M1 band3 as example. This command needs a reboot.
AT+KBNDCFG=0,4

-
4. Stop the Stack — It is important to stop the stack beforehand to deactivate the cellular communication stack temporarily. The command that can be used is: **at+cfun=4**
 5. Deactivate PSM — Power Saving Mode (PSM) must be deactivated if it is currently enabled. PSM is a feature that allows a device to enter a low-power state when it is not actively communicating. The command that can be used to deactivate PSM is: **at+cpsms=0**
 6. Activate eDRX in Cat-M1 — Use the following to activate eDRX in Cat-M1. The **at+cedrxs** parameters are as follows:
 - 1 — Activate eDRX
 - 4 — Use CatM1 technology
 - 5 — Set the requested eDRX value to 81.92 seconds.

The command that can be used is: **at+cedrxs=1,4,5**

7. Activate Hibernating Mode — Put the module in a low power state using eDRX, with the ability to wake it up using an external WAKE_UP pin. The command that can be used is: **at+ksleep=1,2**
8. Activate Unsolicited Commands for EPS — Activate unsolicited commands related to EPS registration. The command that can be used is: **at+cereg=4**
9. Start the Stack — Start the cellular communication stack, possibly after configuring the module for hibernate mode. The command that can be used is: **at+cfun=1**
10. Verify eDRX Activation — Before testing, confirm the activation of eDRX mode with specific values such as CatM1, requested and given eDRX values, and the assigned Paging Time Window (PTW). The command that can be used is: **at+cedrxrdp**

The terminal should have a similar response to this:

+CEDRXRDP: 4, "0101", "0101", "0011"

The parameters are defined as follows:

- 4 — CatM1
- 5 — Requested eDRX value (81.92sec) or eDRX value given by the network (81.92sec)
- 3 — assigned PTW (5.12 sec)

PSM

Use the following AT commands to set up the Power Saving Mode (PSM).

1. Select Cat-M1 — Select Cat-M1 as the LTE category. This command needs a reboot. The command that can be used is: **AT%RATIMGSEL=1**
2. Select Band — Select Cat-M1 band3 as example. This command needs a reboot. The command that can be used is: **AT+KBNDCFG=0,4**
3. Stop the Stack — It is important to stop the stack beforehand to deactivate the cellular communication stack temporarily. The command that can be used is: **at+cfun=4**
4. Configure PSM — Configure PSM using the command below. In this example, the values "00000110" and "00001010" represent the parameters for T3412 (1 hour) and T3324 (20 seconds), respectively. The command that can be used is: **AT+CPSMS=1,,,"00000110";"00001010"**
5. Disable eDRX in Cat-M1 — The command that can be used is: **at+cedrxs=0**
6. Activate Hibernating Mode — Put the module in a low-power state using eDRX, with the ability to wake it up using an external WAKE_UP pin. The command that can be used is **at+ksleep=1,2**
7. Activate Unsolicited Commands for EPS — Activate unsolicited commands related to EPS registration. The command that can be used is: **at+cereg=4**
8. Start the Stack — Start the cellular communication stack, possibly after configuring the module for hibernate mode. The command that can be used is: **at+cfun=1**

Current Measurement

Refer to the following steps for enabling current measurement.

1. Follow the CMW500 and Otii setup.
2. Set Otii GPO1 as high to assert the Wake Up pin.
3. Follow the AT commands setup.
4. Set Otii GPO1 low to de-assert the Wake Up pin, allowing the module to hibernate.
5. Click the record icon to start recording and reading the current measurement.

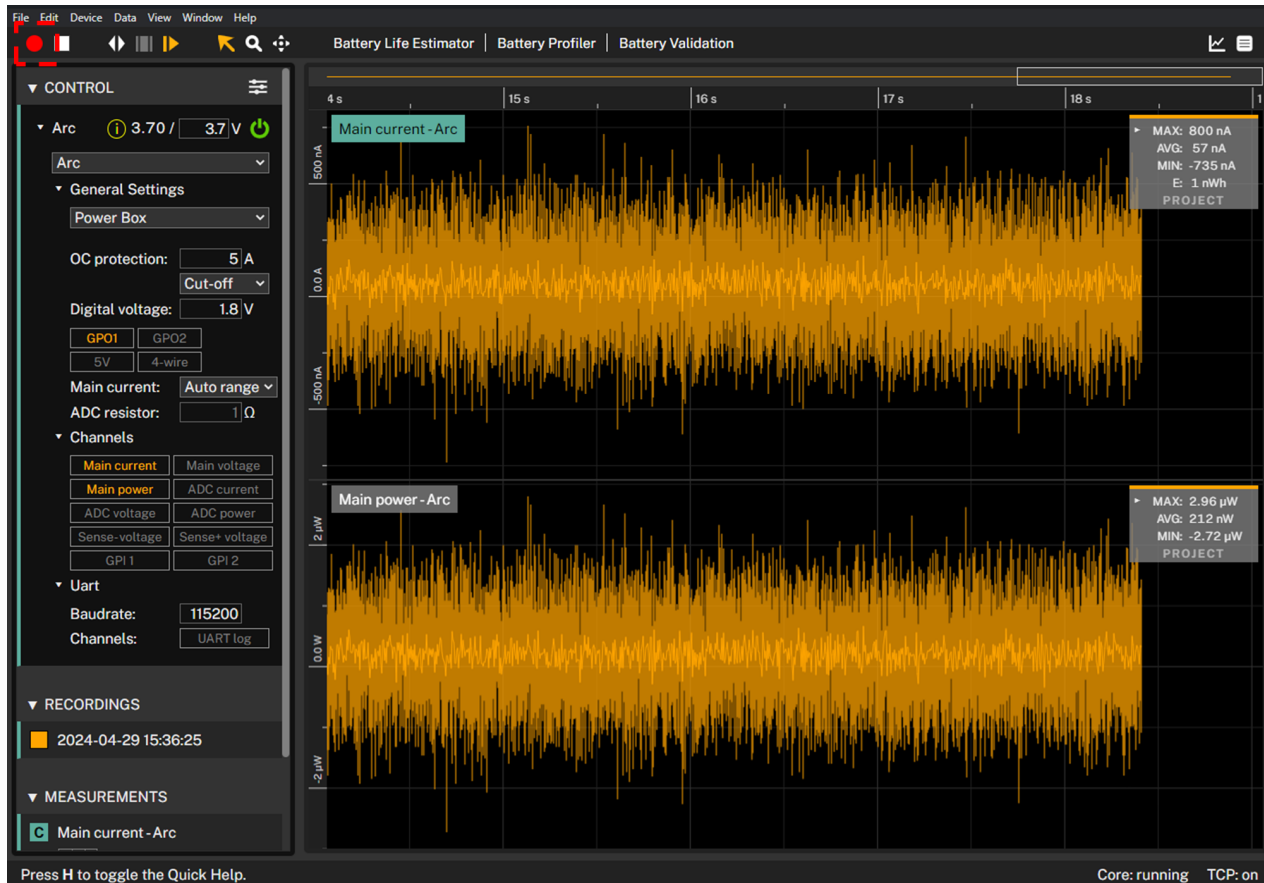

6. The result should be as shown below:

a. PSM



b. eDRX



Document History

Revision number	Release date	Changes
1	July 2024	Document creation, preliminary release

Important Notice

Information relating to this product and the application or design described herein is believed to be reliable, however such information is provided as a guide only and Semtech assumes no liability for any errors in this document, or for the application or design described herein.

Semtech reserves the right to make changes to the product or this document at any time without notice. Buyers should obtain the latest relevant information before placing orders and should verify that such information is current and complete. Semtech warrants performance of its products to the specifications applicable at the time of sale, and all sales are made in accordance with Semtech's standard terms and conditions of sale.

SEMTECH PRODUCTS ARE NOT DESIGNED, INTENDED, AUTHORIZED OR WARRANTED TO BE SUITABLE FOR USE IN LIFE-SUPPORT APPLICATIONS, DEVICES OR SYSTEMS, OR IN NUCLEAR APPLICATIONS IN WHICH THE FAILURE COULD BE REASONABLY EXPECTED TO RESULT IN PERSONAL INJURY, LOSS OF LIFE OR SEVERE PROPERTY OR ENVIRONMENTAL DAMAGE. INCLUSION OF SEMTECH PRODUCTS IN SUCH APPLICATIONS IS UNDERSTOOD TO BE UNDERTAKEN SOLELY AT THE CUSTOMER'S OWN RISK.

Should a customer purchase or use Semtech products for any such unauthorized application, the customer shall indemnify and hold Semtech and its officers, employees, subsidiaries, affiliates, and distributors harmless against all claims, costs damages and attorney fees which could arise.

The Semtech name and logo are registered trademarks of the Semtech Corporation. All other trademarks and trade names mentioned may be marks and names of Semtech or their respective companies. Semtech reserves the right to make changes to, or discontinue any products described in this document without further notice. Semtech makes no warranty, representation or guarantee, express or implied, regarding the suitability of its products for any particular purpose. All rights reserved.

© Semtech 2024

Wireless Communications

Due to the nature of wireless communications, transmission and reception of data can never be guaranteed. Data may be delayed, corrupted (i.e., have errors) or be totally lost. The Semtech product should not be used in situations where failure to transmit or receive data could result in damage of any kind to the user or any other party, including but not limited to personal injury, death, or loss of property. Semtech accepts no responsibility for damages of any kind resulting from delays or errors in data transmitted or received using the Semtech product, or for failure of the Semtech product to transmit or receive such data.

Safety

Do not operate the Semtech product in areas where blasting is in progress, where explosive atmospheres may be present, near medical equipment, near life support equipment, or near any equipment which may be susceptible to any form of radio interference. In such areas, the Semtech product should be powered off.

Qualcomm Licenses

Semtech's cellular modules are sold subject to certain notices and restrictions regarding patent licenses from Qualcomm Incorporated. These notices and restrictions are available at www.sierrawireless.com/qualcomm-notices.

Sierra Wireless

Semtech Corporation purchased Sierra Wireless in January 2023. The Sierra Wireless brand is gradually being phased out. During the phase-out period, references to both “Semtech” and “Sierra Wireless” may appear in product documentation.

Contact Information

Sales information and technical support, including warranty and returns	Web: sierrawireless.com/company/contact-us/ Global toll-free number: 1-877-687-7795 6:00 am to 5:00 pm PST
Corporate and product information	Web: sierrawireless.com

About Semtech

Semtech Corporation (Nasdaq: SMTC) is a high-performance semiconductor, IoT systems, and cloud connectivity service provider dedicated to delivering high-quality technology solutions that enable a smarter, more connected, and sustainable planet. Our global teams are committed to empowering solution architects and application developers to develop breakthrough products for the infrastructure, industrial and consumer markets.

To learn more about Semtech technology, visit us at Semtech.com or follow us on [LinkedIn](#) or [X](#).