

HEAD OFFICE

Kiveton Park, Kiveton Park Station,
Sheffield S26 6NP

www.ibstock.co.uk

T: 0333 999 2220

E: enquiries@ibstock.co.uk

STOCKIST GUIDE ISSUE 24

WE ARE

Fencing, Landscaping, Structural,
Flooring, Bricks and Masonry products
and more.



Ibstock
At the heart of building



Ibstock
At the heart of building

SUPREME
STOCKIST
GUIDE
ISSUE 24

WE ARE at the heart of building.

We offer a diverse range of building products, solutions and expert technical and design services that enable our customers to create inspirational spaces and places.

Everything we do revolves around our valued customers and we continuously strive to exceed their expectations. We pride ourselves on leading for new, innovative and sustainable products and solutions, both for today and for a new era of building.

WE ARE at the heart of building. WE ARE Ibstock.



Bricks and Masonry

Our bricks and masonry range is truly comprehensive. Take the widest brick range in the UK and add in walling stone, architectural masonry, cast stone products and specials and you are sure to find a product for your project.

Facade Systems

With the establishment of Ibstock Futures, Ibstock is demonstrating a clear ambition to grow into the Facades sector. With Ibstock Telling GRC, Mechslip, Nexus and Genbrix we already have some fantastic solutions for this space.

Roofing

Our wide range of concrete roof tiles for the new build housing market, including the innovative SL8 and Gemini products, added to our high quality chimney options from Ibstock Kevington mean we've really got roofing covered.

Flooring and Lintels

A comprehensive range of flooring solutions and lintel products, including high fire rated options – with nationwide coverage delivered through our Supreme and Longley brands.

Staircases and Lift Shafts

Our bespoke high quality, Longley precast staircases and lift shafts are designed to meet your projects exact requirements.

Fencing and Landscaping

Ibstock offers a wide range of products for the fencing and landscaping sector – including high quality concrete fence posts from our Supreme brand or beautiful cast stone balustrades and pier caps from our Forticrete brand.

Retaining Walls

Whether it is a retaining wall solution to prepare a new site or for a major infrastructure scheme – our Anderton brand gives us the products and technical expertise to deliver.

Rail and Infrastructure

Ibstock Rail and Infrastructure combines rail troughs, signal bases, platform copers and other products for infrastructure from our Anderton range – all harnessing the latest in concrete technology to minimise embodied carbon without compromising performance.

Design and Technical Services

We are committed to providing the best possible design and technical support to our customers. From expert advice to a sector-leading training and CPD provision, Ibstock's range of design and technical services are especially configured to give architects and specifiers the access to the support they need at every stage on their project journey – from concept to build.



CONTENTS

IBSTOCK	02
WE ARE Istock	02

PRECAST	06
Istock's precast concrete solutions	06

SUSTAINABILITY	08
ESG Strategy	08
EcoHabitats	10

FENCING	12
DOMESTIC	
Slotted posts and gravel boards for wooden panel fences	16
Gravel boards – Original and Smoothcast	18
Strongcast Original™ – the top selling slotted post	18
Strongcast Ultra™ – a lightweight slotted post	19
Gravel boards – Ultra™	19
Repair spurs	19
Morticed posts, recessed posts and gravel boards for closeboard fence	20
Morticed posts	20
Recessed posts	22
Gravel boards	23
Gravel board fixer	23
COMMERCIAL	
Chainlink and strained wire fence posts	24-30
Chainlink posts	26
Gate posts	27
Cranked top posts	28
Straight top posts	29
Strained wire posts	30
Concrete panel walling system	30
Heavy duty slotted posts	30
Panel walling	30
Miscellaneous posts	31
Universal posts	31
Barrel rail posts	31

BUILDING	32
Caps and copings	
Pier caps	34-36
Twice weathered copings	34
Once weathered copings	35
Flat copings	35
Buff pier caps	36
Buff copings	36
General building products	
Chimney caps	36-37
Window sill	36
Gully surround	37
Door step	37
Clothes line posts	37
Rectangular inspection chambers	37

LANDSCAPING	38
Bollards	40
Path edging	41
Tuff Turf	42
DekBlok™ and DekPost™	42
Cycle blocks	43
Screed rails	43

STRUCTURAL	40
Lintels and padstones	
Prestressed premium and precast lintels and padstones	46-52
High Fire Rated & Extreme Fire Rated Lintels	46-47
Hi-strength lintels textured finish	48-49
Precast lintels	51
Padstones	53
Fireplace lintels	54
Floor beams	55
Suspended beam and block floor	55
Design and supply solution	56
Beams in stock	57
Floor beam promise	60
Delivery and contact information	61

IBSTOCK SUPPORT

			
ON TIME IN FULL	NATIONAL COVERAGE	SALES SUPPORT	MERCHANT FOCUS

THE IBSTOCK PRECAST OFFERING

Ibstock offers a diverse range of precast concrete suspended floors, including Beam and Block, Hollowcore and Insulated flooring systems, along with manufacturing and installing precast concrete lift shafts, staircases and landings.

60,000 OVER 60,000
NEW HOMES A YEAR

170 170
NEW HOMES A DAY



MANUFACTURING, INSTALLATION AND SUPPLY

With specialist precast factories in West Yorkshire and Ireland, Ibstock supplies to most major housebuilders, builders' merchants and groundwork contractors across the country.

Their qualified installation teams have extensive experience of installing their concrete products on sites across the UK and Ireland. In addition, their staff have in-depth skills and knowledge of the products supplied which means that your installation will run smoothly while ensuring that your build program remains on schedule and is cost effective.

See our full range of products at
www.ibstock.co.uk

Our product range



STAIRCASES

Precast concrete stairs save both time and money with the elimination of site shuttering and scaffolding, resulting in reduced construction costs.

Concrete stairs offer acoustic insulation and will significantly reduce noise caused by people moving around a building, making them an ideal choice for commercial and residential use. Ibstock offers bespoke, precast concrete stairs and landings designed and installed to your project's exact requirements.

BEAM AND BLOCK

Beam and block flooring is a highly practical solution for ground and upper floors. Quick and easy to install in all weather conditions without the need for specialist skills, beam and block flooring creates an immediate and safe level working platform.

For the homeowner, a beam and block floor provides a high level of thermal insulation and fire resistance, and concrete beams help to reduce noise transmittance through floors.

Ibstock's standard or wide beam solutions are well suited to open plan designs with large span requirements. Beam and block floors are an excellent alternative to concrete slab and timber floor and are maintenance free.

LIFT SHAFTS

Precast concrete modular lift shafts radically simplify lift shafts during installation, through to operation and maintenance.

Concrete sections are manufactured to the highest standard in controlled factory conditions and are simply stacked on top of one another on site, reducing installation time, which greatly assists the build programme schedule.

Ibstock manufacture bespoke lift shafts up to 6 storeys that are designed to support all loading from the lift equipment during installation, through to operation and maintenance.

HOLLOWCORE

Hollowcore flooring is an efficient and modern flooring solution that can be used within a great many structures. It incorporates precast concrete with longitudinal voids.

Hollowcore is the ideal solution for those who are looking to take advantage of the strength of traditional concrete while simultaneously enjoying low weight and high load capacity. The use of precast concrete Hollowcore flooring is a highly cost-effective solution that fits easily into any structural system such as steel or concrete frame or masonry construction.

STADIA

Ibstock has provided precast concrete stadia and tiered seating for a number of sports venues and stadiums.

Manufactured offsite and installed by their trained and qualified team. The bespoke stadia are quick to install and provide an immediate seating platform. With over 70 years of experience producing precast concrete products, their stadia are designed to be robust, fire resistant and safe.

INSULATED FLOORING

Ibstock has been at the forefront of precast concrete flooring manufacture and design for over 70 years. Increasingly there has been a need for new homes to be energy efficient and to have better thermal performance.

The insulating flooring solutions deliver a robust, stable and quick-to-install option for housebuilders looking to achieve a more efficient home. Two insulated flooring systems are offered, both utilising EPS insulation panels in place of traditional concrete blocks. Both systems achieve excellent U values, hold an Agreement certification and are accepted by the NHBC.

THE IBSTOCK ESG STRATEGY 2030

Our guiding purpose is to build a better world by being at the heart of building. To achieve this, we have developed an Environmental, Social and Governance Strategy, our ESG Strategy 2030, simplifying the way we articulate our goals and ambitions.

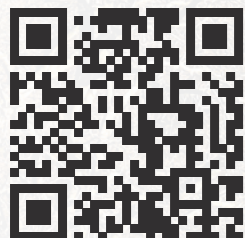

Please scan the QR code to find out more.

Carbon reduction
Reduce absolute Carbon (Scope 1 and 2) by 40% against 2019 baseline.

Water efficiency
Reduce mains water use by 25% per tonne of production against a 2019 baseline.

Biodiversity net gain
Achieve Biodiversity Net Gain across our estate using Biodiversity Metric 2.0.

Product innovation
Achieve 20% sales turnover from new products and solutions that deliver customer value and improved sustainability.

Dematerialisation
Reduce raw materials consumption with a focus on plastics, secondary aggregate and cementitious replacements.

Circular economy
Embed circular economy principles into the business, prioritising zero waste and driving demand for secondary materials markets.



Health, safety & wellbeing
Ensure all our employees can be at their best more of the time through our health, safety and wellbeing strategies.

Inspiring futures
Provide development and growth for all, with every employee developing their skills annually and 10% in Earn and Learn positions.

Employee experience
Increase female senior leadership representation to 40% by 2027 as part of our proactive approach to diversity and inclusion.

2022 Accelerating change

2030 Scaling solutions

2040

2050

SCOPE 1 AND 2

- Energy from alternative sources
- 100% of Mobile Plant and company cars hybrid and/or electric
- Biodiversity Net Gain
- Commissioning of Atlas factory
- Commissioning of Nostell Brick slips systems factory
- Major capital investments

- Energy from alternative sources
- Expansion of diversified product portfolio
- Core products = low carbon products
- Circularity embedded
- Carbon capture use and storage scaled
- Balance any remaining emissions that cannot be eliminated with natural or technical solutions

NET ZERO FOR SCOPE 1 AND 2 EMISSIONS BY 2040



SCOPE 3

Accurate and transparent data reporting

40 Working with our top 40 suppliers

Continuous engagement and collaboration

Partnership projects

NET ZERO SCOPE 3 EMISSIONS BEFORE 2050

* Continued operational efficiency & estate renewal

IBSTOCK EcoHABITATS

Our EcoHabitat range is designed to provide safe spaces for bees, bats, swifts, hedgehogs, sparrows and starlings, enabling them to live in harmony with people.

With an increasing number of our customers now applying Biodiversity Net Gain Principles (BNG) to new developments – the guarantee that a site will have a positive ecological impact upon completion – Ibstock is investing in our built-in EcoHabitat range to support these gains through the lifetime of the homes our customers build.

Developing our product range to help tackle nature loss and promote biodiversity is a key part of Ibstock's sustainability strategy.

We are taking action on our own sites across the UK as we work towards being a BNG business as well as supporting our customers to achieve their own sustainability goals.

Ibstock EcoHabitats are designed to work with Ibstock's wider range of construction products, no special skills are required for install beyond normal professional practise, making them easy to include in a standard construction.



For more information on our EcoHabitats range of products and to discuss your project requirements, please email ecohabitats@ibstock.co.uk

Concrete Beehabitats

BeeHabitat - Concrete



CONCRETE BEEHABITATS			
ITEM CODE	ITEM NAME	ITEM DESCRIPTION	L x W x D (mm)
BEEHABITAT-ASBOW	Anstone Split Black Old Weathered	BeeHabitat	225 x 100 x 140
BEEHABITAT-ASBB	Anstone Split Black Buff	BeeHabitat	225 x 100 x 140
BEEHABITAT-SSBOH	Shearstone Split Blackmoor Olde Heather	BeeHabitat	220 x 100 x 140
BEEHABITAT-SSCV	Shearstone Split Cotswold Village	BeeHabitat	220 x 100 x 140

Bespoke finishes available on all products - please contact for more information

Concrete Product Range



CONCRETE PRODUCT RANGE				
ITEM CODE	ITEM NAME	ITEM DESCRIPTION	L x W x D (mm)	APERTURE
CEB/7996/BBOX/BT	Bat Box	MTO Bat Box Bath	440 x 100 x 215	60 x 55
CEB/7996/SBOX/BT	Swift Box	MTO Swift Box Bath	327.5 x 150 x 140	46 x 31
GBR295HPR	Gravel Board	Hedgehog Gravel Board	1830 x 295 x 47	-

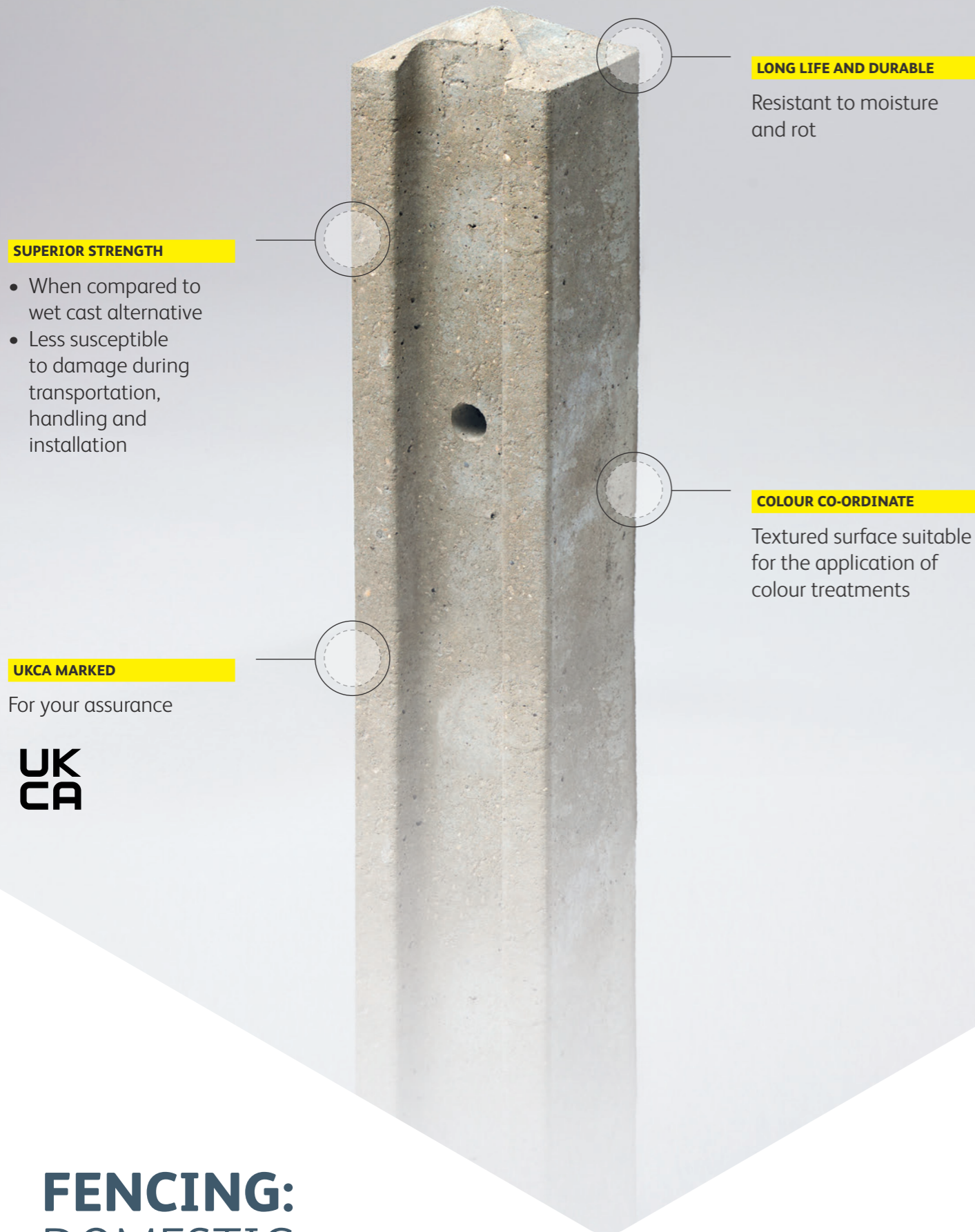

SUPERIOR STRENGTH

- When compared to wet cast alternative
- Less susceptible to damage during transportation, handling and installation

LONG LIFE AND DURABLE

Resistant to moisture and rot

COLOUR CO-ORDINATE

Textured surface suitable for the application of colour treatments

UKCA MARKED

For your assurance



**FENCING:
DOMESTIC**

Fencing is one of our core areas of expertise.

We have developed the country's most popular range of concrete fencing products, to meet all of your customers' needs.



STRONGCAST PROFESSIONAL

FEATURES AND BENEFITS

Ibstock's new **STRONGCAST PROFESSIONAL** range aims to be best in class for its finish, quality, weight, strength and functionality. With lower embodied carbon, we are continually making improvements to our products to meet the requirements of our customers.

- Improved sustainability with up to 35% less embodied carbon vs the Strongcast Original Range
- Improved strength delivering a Class A wind rating in accordance with EN 12839
- Includes EcoHabitat products, namely a Hedgehog gravel board
- Posts include a dig depth reference point

See pages 14 and 15 for full details on the new Strongcast Professional range.



STRONGCAST ORIGINAL™

FEATURES AND BENEFITS

This is a unique process, using a special semi-dry concrete, which is compacted by vibration to give high strength and durability.

- All posts and gravel boards are steel reinforced for extra strength and long life. **STRONGCAST ORIGINAL™** products are available in six lengths including the new 10 foot post and are completely unaffected by moisture or rot
- Products have a slightly more textured appearance than wet-cast concrete
- A range of surface treatments may be used to colour and co-ordinate with modern garden colour schemes
- UKCA marked for your assurance



STRONGCAST ULTRA™

FEATURES AND BENEFITS

STRONGCAST ULTRA™ offers all the benefits of Ibstock Original in a lighter, easier to handle post.

- Up to 45% lighter than existing products for equivalent use
- Easy to handle
- Faster installation
- A range of new style gravel boards are available
- **STRONGCAST ULTRA™** slotted posts are available in six different lengths
- Posts can be used either way up, i.e. 4-way weathered "pyramid" design to match existing Ibstock style, or 2-way weathered
- Gravel boards are available in two attractive designs. The 'New Style' is suitable for 1830mm (6') imperial panels or metric 1800mm (5'11") by removal of the "nibs"
- A darker coloured surface finish due to the specialist materials used in manufacture
- A range of surface treatments may be used to colour and co-ordinate with modern garden colour schemes
- UKCA marked for your assurance

Gain more, stock core products

There's never a better time to increase sales, and an easy way is to stock the right range.

FENCING PRODUCT	PRODUCT CODE	BEST SELLERS	DEVELOP YOUR RANGE
Strongcast Original	SLT2441 (8')	✓	✓
Standard fence panel	SLT2741 (9')	✓	✓
	SLT244C (8')		✓
	SLT274C (9')		✓
	SLT1831 (6')		✓
	SLT2131 (7')		✓
	SLT3041 (10')		✓
Close board fencing	MRT2441 (8')		✓
	MRT2751 (9')		✓
	GBL28815 (morticed and recessed)		✓
Gravel board	GBR305 (recessed)	✓	✓
	GBR150 (recessed)	✓	✓
	GBS305 (smooth)	✓	✓
	GBS150 (smooth)	✓	✓
	GBROC 305 (rock faced)	✓	✓
Repair spur	SPR100	✓	✓
	SPR120	✓	✓



- Prevents rattling
- Stops fence panel lifting
- Quick and easy to install
- Fence panel security clip for use with Strongcast Original and Ultra
- Slotted posts

What do we sell?

- Strongcast slotted posts
- Gravel boards for wooden panel fences
- Repair spurs
- Pointed top morticed posts
- Round top morticed posts
- TZ morticed posts
- Back weathered mortice posts
- Recessed posts
- Gravel board fixer







STRONGCAST PROFESSIONAL

We are the market leaders for fencing in the UK, with a long-held commitment to product development and innovation. Much of this innovation is achieved through research and development with you, our customers, helping us to hone our offering to ensure it is truly best in class.

Thanks to continued investment in our manufacturing capabilities in recent years, we have been able to deliver real improvements in natural aggregates, plasticisers and mixing technology – enhancements that have led us to launch **STRONGCAST PROFESSIONAL**, our durable, multi-functional, lightweight range.







Supreme Concrete's new **STRONGCAST PROFESSIONAL** range aims to be best in class for its finish, quality, weight, strength and functionality. With lower embodied carbon, we are continually making improvements to our products to meet the requirements of our customers.

LIGHTER AND MORE VERSATILE		NEW INNOVATIONS	
<p>25%* LIGHTER</p> 	<p>LIGHTER A reduced section size has been achieved through the use of a super steel reinforcement cage, better aggregates, advanced plasticisers and a unique curing process.</p>		<p>GRAVEL BOARD FIXER Unique retention hole to allow a gravel board to be supported by a fixing pin to overcome unstable or sloping ground conditions.</p>
<p>35%* LIGHTER</p> 	<p>CORNER OPTION The most frequently used size of this product usually weighs in excess of 75kg. We have created it at a weight of just 50kg, resulting in only a 2 person lift.</p>		<p>SCORPION CLIPS Quick and easy to install anti-rattling device.</p>
	<p>3 WAY OPTION A semi-dry 3 way option is a firm favourite for large contractors and larger developments. Through investment in our manufacturing capability, we are proud to be the first to offer you a professional and complete solution when it comes to different installation layouts.</p>		<p>DIG DEPTH REFERENCE All Strongcast Professional posts will include a dig depth reference point to assist with achieving consistent depths and horizontal alignment.</p>

* vs. the Strongcast Original Range

IMPROVED SUSTAINABILITY	IMPROVED STRENGTH	HEDGEHOG GRAVEL BOARD
 <p>Up to 35% less embodied carbon vs the Strongcast Original Range</p>	 <p>Delivers a Class A wind rating in accordance with EN12839.* <small>*applies to product SLT244IPR</small></p>	 <p>The protection of our environment is key to us, which is why we have included a gravel board option that includes a 13cm diameter hole, allowing hedgehogs to roam freely.</p>

Strongcast Professional range

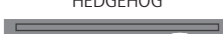
STRONGCAST PROFESSIONAL SLOTTED POSTS							
TYPE	IMPERIAL	METRIC	PACK SIZE	PRODUCT CODE	PRODUCT WEIGHT (KG)	PRODUCT PACK WEIGHT (KG)*	
	5ft	1524 x 80 x 104	36	SLT152IPR	21	756	
	6ft	1830 x 80 x 104	36	SLT183IPR	25	900	
	7ft	2134 x 80 x 104	36	SLT213IPR	29	1044	
	8ft	2440 x 80 x 104	36	SLT244IPR	33	1188	
	9ft	2743 x 80 x 104	36	SLT274IPR	37	1332	
	10ft	3048 x 80 x 104	18	SLT304IPR	42	756	
	5ft	1524 x 80 x 104	6	SLT152EPR	24	144	
	6ft	1830 x 80 x 104	6	SLT183EPR	29	174	
	7ft	2134 x 80 x 104	6	SLT213EPR	34	204	
	8ft	2440 x 80 x 104	6	SLT244EPR	39	234	
	9ft	2743 x 80 x 104	6	SLT274EPR	43	258	
	10ft	3048 x 80 x 104	6	SLT304EPR	48	288	
	5ft	1524 x 110 x 106	6	SLT152CPR	32	192	
	6ft	1830 x 110 x 106	6	SLT183CPR	38	228	
	7ft	2134 x 110 x 106	6	SLT213CPR	45	270	
	8ft	2440 x 110 x 106	6	SLT244CPR	50	306	
	9ft	2743 x 110 x 106	6	SLT274CPR	57	342	
	10ft	3048 x 110 x 106	6	SLT304CPR	63	378	
	5ft	1524 x 110 x 106	6	SLT1523WPR	27	162	
	6ft	1830 x 110 x 106	6	SLT1833WPR	33	198	
	7ft	2134 x 110 x 106	6	SLT2133WPR	38	228	
	8ft	2440 x 110 x 106	6	SLT2443WPR	44	264	
	9ft	2743 x 110 x 106	6	SLT2743WPR	50	300	
	10ft	3048 x 110 x 106	6	SLT3043WPR	55	330	
STRONGCAST PROFESSIONAL RECESSED GRAVEL BOARDS							
	RECESSED	12"	1830 x 295 x 45	20	GBR295PR	42	846
		6"	1830 x 140 x 45	40	GBR140PR	22	893
	HEDGEHOG	12"	1830 x 295 x 45	5	GBR295HPR	41	206

*excludes pallet and packaging



Range options

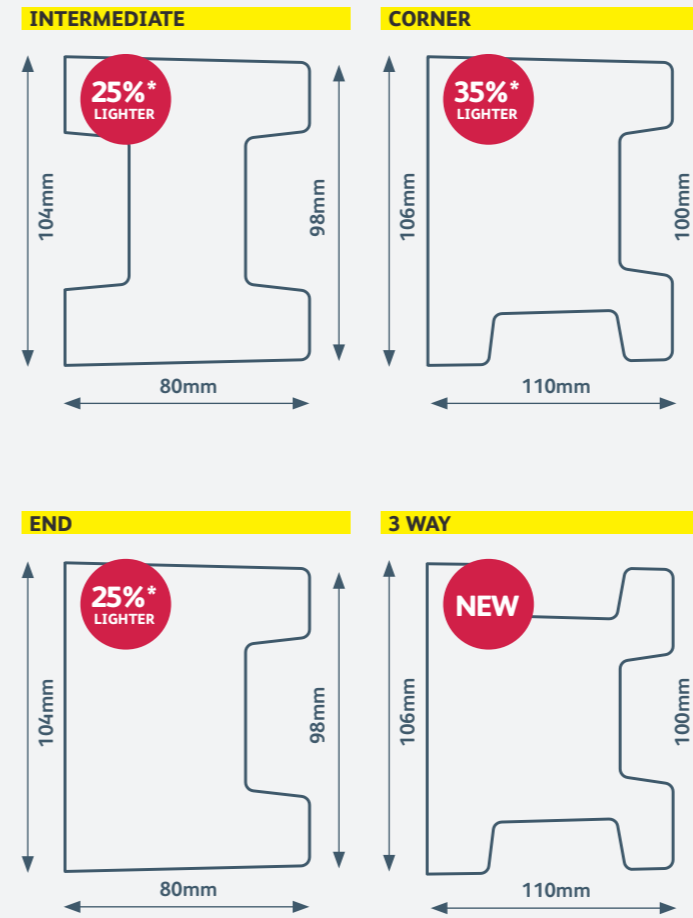

* vs. the Strongcast Original Range

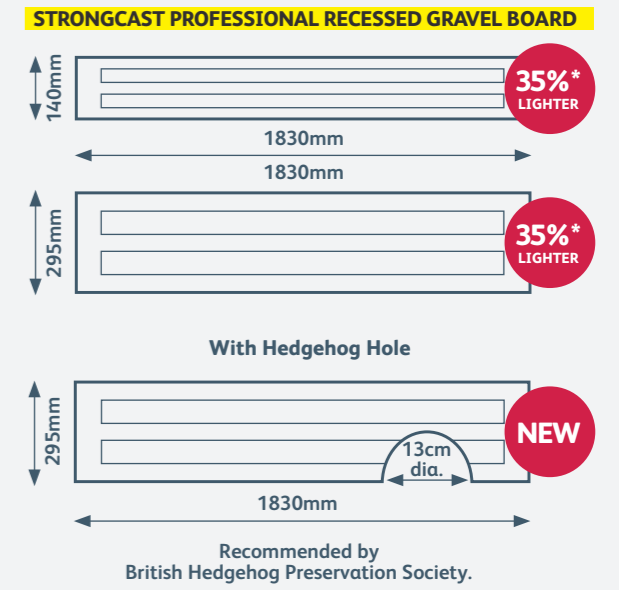

Slotted posts, gravel boards and repair spurs

SLOTTED POSTS FOR PANEL FENCING

Strongcast slotted concrete posts have become the most popular choice for panel fencing. Like all Istock posts, they are made from high strength concrete, reinforced for ultimate durability and long life. Easy to install and cost-effective,

these products are completely unaffected by moisture and rot and will give years of extra life to any panel fencing installation. Strongcast slotted posts are available in six sizes.

STRONGCAST ORIGINAL™ SLOTTED POSTS								
TYPE	METRIC (MM)	IMPERIAL	DIMENSIONS (MM)	PACK QUANTITY	PACK WEIGHT (KG)	PRODUCT CODE	SPLIT PRICE EACH (£)	PACK PRICE EACH (£)
INTERMEDIATE	1525	5'	94 x 109	36	972	SLT 152I	30.84	23.65
	1830	6'	94 x 109	36	1235	SLT 183I	31.65	24.31
	2135	7'	94 x 109	36	1429	SLT 213I	32.43	24.96
	2440	8'	94 x 109	36	1559	SLT 244I	33.21	25.66
	2745	9'	94 x 109	36	1865	SLT 274I	40.03	30.87
	3040	10'	94 x 109	18	1064	SLT 304I	50.06	38.59
CORNER	1525	5'	125 x 125	6	285	SLT 152C	53.64	41.23
	1830	6'	125 x 125	6	345	SLT 183C	59.54	45.83
	2135	7'	125 x 125	6	420	SLT 213C	68.23	52.53
	2440	8'	125 x 125	6	450	SLT 244C	74.84	57.65
	2745	9'	125 x 125	6	530	SLT 274C	79.27	61.01
	3040	10'	125 x 125	6	606	SLT 304C	—	73.23
END POST	1525	5'	94 x 109	6	190	SLT 152E	37.37	28.75
	1830	6'	94 x 109	6	220	SLT 183E	42.37	32.60
	2135	7'	94 x 109	6	255	SLT 213E	47.01	36.16
	2440	8'	94 x 109	6	305	SLT 244E	48.66	37.34
	2745	9'	94 x 109	6	340	SLT 274E	57.26	44.01
	3040	10'	94 x 109	6	392	SLT 304E	—	52.81

Slots are 55mm (w) x 20mm (d)

GRAVEL BOARDS

Gravel boards prevent rot at the bottom of the wooden panel, adding considerably to the life of the fence. Available in four styles, 1830mm (6') long to correspond with standard panel lengths and two heights 150mm (6") and

305mm (12"). 1800mm (5'11") long gravel boards are also available. Our Smoothcast gravel boards feature a 'hand floated' finish to the reverse side for a more attractive finish.

STRONGCAST ORIGINAL™ RECESSED GRAVEL BOARDS							
TYPE	DIMENSIONS (MM)	IMPERIAL	PACK QUANTITY	PACK WEIGHT (KG)	PRODUCT CODE	SPLIT PRICE EACH (£)	PACK PRICE EACH (£)
RECESSED	1830 x 150 x 50	6"	40	1020	GBR 150	22.46	17.24
	1830 x 305 x 50	12"	20	980	GBR 305	36.86	28.40

SMOOTHCAST GRAVEL BOARDS							
TYPE	DIMENSIONS (MM)	IMPERIAL	PACK QUANTITY	PACK WEIGHT (KG)	PRODUCT CODE	SPLIT PRICE EACH (£)	PACK PRICE EACH (£)
SMOOTH FACED	1800 x 150 x 50	6"	40	1360	GBM 18015	23.96	19.99
	1800 x 300 x 50	12"	20	1340	GBM 18030	37.09	30.89
	1830 x 150 x 50	6"	40	1220	GBS 150	21.88	18.18
	1830 x 300 x 50	12"	20	1220	GBS 305	35.04	29.25
ROCK FACED	1830 x 295 x 50	12"	15	860	GBROC 305	36.51	30.46
MEDIUM PROFILE	1830 x 305 x 50	12"	20	1080	GBROC 305MP	36.51	30.46

STRONGCAST ULTRA™ SLOTTED POSTS								
TYPE	METRIC (MM)	IMPERIAL	DIMENSIONS (MM)	PACK QUANTITY	PACK WEIGHT (KG)	PRODUCT CODE	SPLIT PRICE EACH (£)	PACK PRICE EACH (£)
INTERMEDIATE	1370	4'6"	84 x 106	36	620	SLT 137IL	36.88	28.40
	1750	5'9"	84 x 106	36	716	SLT 175IL	37.92	29.19
	2050	6'9"	84 x 106	36	814	SLT 205IL	39.00	29.97
	2360	7'9"	84 x 106	36	1004	SLT 236IL	39.98	30.76
	2660	8'9"	84 x 106	36	1168	SLT 266IL	48.10	36.95
	2972	9'9"	84 x 106	18	666	SLT 297IL	—	44.38
CORNER	1370	4'6"	125 x 125	6	230	SLT 137CL	64.36	49.43
	1750	5'9"	125 x 125	6	277	SLT 175CL	71.36	54.84
	2050	6'9"	125 x 125	6	318	SLT 205CL	81.86	62.93
	2360	7'9"	125 x 125	6	330	SLT 236CL	89.86	69.11
	2660	8'9"	125 x 125	6	385	SLT 266CL	95.13	73.06
	2972	9'9"	125 x 125	6	510	SLT 297CL	—	87.71
END POST	1370	4'6"	84 x 106	6	123	SLT 137EL	44.82	34.48
	1750	5'9"	84 x 106	6	153	SLT 175EL	50.93	39.17
	2050	6'9"	84 x 106	6	177	SLT 205EL	56.46	43.43
	2360	7'9"	84 x 106	6	203	SLT 236EL	58.33	44.87
	2660	8'9"	84 x 106	6	227	SLT 266EL	68.57	52.78
	2972	9'9"	84 x 106	6	253	SLT 297EL	—	63.35

STRONGCAST ULTRA™ RECESSED GRAVEL BOARDS							
TYPE	DIMENSIONS (MM)	IMPERIAL	PACK QUANTITY	PACK WEIGHT (KG)	PRODUCT CODE	SPLIT PRICE EACH (£)	PACK PRICE EACH (£)
NEW STYLE	1830/1800 x 145 x 50	6"	40	701	GBR 145L	26.87	20.68
	1830/1800 x 295 x 50	12"	20	602	GBR 295L	44.36	34.10
ORIGINAL	1830 x 150 x 50	6"	40	768	GBR 150L	26.87	20.68
	1830 x 305 x 50	12"	20	727	GBR 305L	44.36	34.10

STRONGCAST PROFESSIONAL™ GRAVEL BOARDS							
TYPE	DIMENSIONS (MM)	IMPERIAL	PACK QUANTITY	PACK WEIGHT (KG)	PRODUCT CODE	SPLIT PRICE EACH (£)	PACK PRICE EACH (£)
HEDGEHOG	1830 x 295 x 47	12"	5	173	GBR295HPR	44.85	34.48

The 'new style' gravel boards have been designed with nibs to suit both metric (1800mm) and imperial (1830mm) fence panels. The nibs can be easily removed with an appropriate mechanical cutting tool. This means that you only need to stock one gravel board to suit both metric and imperial panels.

REPAIR SPURS

A unique and durable alternative to replacing the whole fence.

Where today's wooden posts have been used they will be subject to rot attack at ground level and will require replacement at some point.

METRIC (MM)	IMPERIAL	DIMENSIONS (MM)	PACK QUANTITY	PACK WEIGHT (KG)	PRODUCT CODE	SPLIT PRICE EACH (£)	PACK PRICE EACH (£)
1000	3'3"	75 x 75	80	1032	SPR 100	16.27	12.47
1050	3'6"	100 x 100	36	889	SPR 105	17.33	13.35
1200	4'	100 x 75	48	994	SPR 1203	18.30	14.11
1200	4'	100 x 100	36	1030	SPR 120	18.30	14.11
1350	4'6"	100 x 100	36	1123	SPR 135	20.81	15.97

Since the introduction of new legislation on the type and use of timber preservatives, we at Istock have seen a 388% increase in the sales of repair spurs!

Prevents fence panels rattling



NEW! - SCORPION FENCE PANEL CLIP		
DESCRIPTION	PRODUCT CODE	PACK PRICE EACH (£)
Pack of 50	FCLIP01	44.42



Dig hole about 2' deep against post.

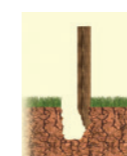

Place spur in hole and mark bolt hole positions.

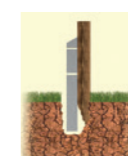

Remove spur and drill post keeping drill level. A 12mm bolt is to be used.

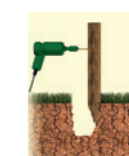

Replace spur and bolt to post. Fill hole with a suitable cement and aggregate mix.

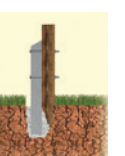

Our Strongcast Ultra Intermediate posts are ideal for a 'one man' lift. Without packaging, up to 7'9", they are lighter than 25kg.

Rotting timber posts? Use our repair spurs.

Morticed posts, recessed posts and gravel boards for closeboard fences

Ibstock manufacture both morticed and recessed posts with complementary gravel boards. The morticed posts allow the posts to be featured while the recessed post enables the post to be concealed.



Long butt morticed posts are extended below ground for extra stability where ground is sloping or unstable.

MORTICED POSTS

Morticed posts for closeboard fencing are available in four styles; pointed top, round top, TZ and back weathered.

POINTED TOP MORTICED POSTS											
TYPE	METRIC (MM)	IMPERIAL	FENCE HEIGHT		RAILS	DIMENSIONS (MM)	PACK QUANTITY	PACK WEIGHT (KG)	PRODUCT CODE	SPLIT PRICE EACH (£)	PACK PRICE EACH (£)
			NO GRAVEL BOARD	GRAVEL BOARD (150MM HIGH)							
INTERMEDIATE	1525	5'	0.75 or 0.9	0.9	2	100 x 100	36	1260	MRT 152I	37.53	28.81
	1830	6'	1.05 or 1.2	1.05 or 1.2	2	100 x 100	36	1494	MRT 183I	42.37	32.60
	2135	7'	1.35 or 1.5	1.35 or 1.5	2	100 x 100	36	1764	MRT 213I	44.79	34.47
	2440	8'	1.65 or 1.8	1.65 or 1.8	3	100 x 100	36	2034	MRT 244I	45.69	35.04
	2745	9' long butt	1.65 or 1.8	1.65 or 1.8	3	100 x 100	36	2315	MRT 274I	54.36	41.77
CORNER	2750	9'	2	1.95	3	100 x 100	18	1170	MRT 275I	56.97	43.80
	1525	5'	0.75 or 0.9	0.9	2	100 x 100	6	220	MRT 152C	45.69	35.04
	1830	6'	1.05 or 1.2	1.05 or 1.2	2	100 x 100	6	265	MRT 183C	51.21	39.40
	2135	7'	1.35 or 1.5	1.35 or 1.5	2	100 x 100	6	300	MRT 213C	55.90	43.08
	2440	8'	1.65 or 1.8	1.65 or 1.8	3	100 x 100	6	350	MRT 244C	57.65	44.35
	2745	9' long butt	1.65 or 1.8	1.65 or 1.8	3	100 x 100	6	381	MRT 274C	70.42	54.22
	2750	9'	2	1.95	3	100 x 100	6	390	MRT 275C	73.75	56.84

ROUND TOP MORTICED POSTS FOR BACK RAIL AND CAPPING											
TYPE	METRIC (MM)	IMPERIAL	FENCE HEIGHT		RAILS	DIMENSIONS (MM)	PACK QUANTITY	PACK WEIGHT (KG)	PRODUCT CODE	SPLIT PRICE EACH (£)	PACK PRICE EACH (£)
			NO GRAVEL BOARD	GRAVEL BOARD (150MM HIGH)							
INTERMEDIATE	2440	8'	1.65 or 1.8	1.8	3	100 x 100	24	1440	MRR 244I4	52.55	40.49
	2440	8'	1.65 or 1.8	1.8	3	125 x 100	24	1800	MRR 244I	63.46	48.88
	3350	11'	2.4	2.4	4	140 x 115	12	1560	MRR 335I	105.73	81.37
CORNER	2440	8'	1.65 or 1.8	1.8	3	100 x 100	6	360	MRR 244C4	62.62	48.15
	3350	11'	2.4	2.4	4	140 x 115	6	780	MRR 335C	120.42	93.48

BS 1722-5 ROUND TOP MORTICED POSTS FOR BACK RAIL AND CAPPING											
TYPE	METRIC (MM)	IMPERIAL	FENCE HEIGHT		RAILS	DIMENSIONS (MM)	PACK QUANTITY	PACK WEIGHT (KG)	PRODUCT CODE	SPLIT PRICE EACH (£)	PACK PRICE EACH (£)
			NO GRAVEL BOARD	GRAVEL BOARD (150MM HIGH)							
INTERMEDIATE	1750	5'9"	1.05	1.05	2	140 x 115	18	1224	MBS 175I	70.85	54.49
	1900	6'3"	1.2	1.2	2	140 x 115	18	1332	MBS 190I	74.84	57.65
	2350	7'9"	1.5	1.5	3	140 x 115	18	1638	MBS 235I	77.66	59.71
	2500	8'3"	1.65	1.65	3	140 x 115	18	1764	MBS 250I	81.12	62.26
	2650	8'8"	1.8	1.8	3	140 x 115	18	1784	MBS 265I	83.61	64.35
CORNER	1750	5'9"	1.05	1.05	2	140 x 115	6	408	MBS 175C	83.61	64.35
	1900	6'3"	1.2	1.2	2	140 x 115	6	450	MBS 190C	87.83	67.40
	2350	7'9"	1.5	1.5	3	140 x 115	6	552	MBS 235C	90.15	69.32
	2500	8'3"	1.65	1.65	3	140 x 115	6	588	MBS 250C	93.68	72.07
	2650	8'8"	1.8	1.8	3	140 x 115	6	618	MBS 265C	96.02	73.82



British Standard posts have a wider profile for greater strength. They are often specified for local authority and public projects.

TZ MORTICED POSTS WITH 200MM (8") HIGH GRAVEL BOARD											
TYPE	METRIC (MM)	IMPERIAL	FENCE HEIGHT		RAILS	DIMENSIONS (MM)	PACK QUANTITY	PACK WEIGHT (KG)	PRODUCT CODE	SPLIT PRICE EACH (£)	PACK PRICE EACH (£)
			NO GRAVEL BOARD	GRAVEL BOARD (150MM HIGH)							
INTERMEDIATE	2440	8'	1.65 or 1.8	1.65 or 1.8	3	100 x 100	36	2102	MTZ 244I	45.69	35.04
	2745	9' long butt	1.65 or 1.8	1.65 or 1.8	3	100 x 100	36	2358	MTZ 274I	54.36	41.77
	2850	9'4"	1.95 or 2.0	1.95 or 2.0*	3	130 x 105	15	1410	MTZ 285I	82.37	63.35
	2950	9'8"	2.1	2.1	3	130 x 105	15	1455	MTZ 295I	84.57	65.02
	3400	11'	2.4	2.4	4	150 x 105	10	1300	MTZ 340I	123.28	94.82
CORNER	2440	8'	1.65 or 1.8	1.65 or 1.8	3	100 x 100	6	355	MTZ 244C	57.65	44.35
	2745	9' long butt	1.65 or 1.8	1.65 or 1.8	3	100 x 100	6	400	MTZ 274C	70.42	54.22
	2850	9'4"	1.95 or 2.0	1.95 or 2.0*	3	130 x 130	5	590	MTZ 285C	115.60	89.05
	2950	9'8"	2.1	2.1	3	130 x 130	5	610	MTZ 295C	120.00	92.37
	3400	11'	2.4	2.4	4	150 x 150	5	950	MTZ 340C	208.04	160.00



Four gravel board cleat holes enable one post size to be used for two fence heights.*

BACK WEATHERED MORTICED POSTS											
TYPE	METRIC (MM)	IMPERIAL	FENCE HEIGHT		RAILS	DIMENSIONS (MM)	PACK QUANTITY	PACK WEIGHT (KG)	PRODUCT CODE	SPLIT PRICE EACH (£)	PACK PRICE EACH (£)
			NO GRAVEL BOARD	GRAVEL BOARD (150MM HIGH)							
INTERMEDIATE	2440	8'	1.65 or 1.8	1.8	3	100 x 100	36	2160	MBW 244I4	52.55	40.49
	2440	8'	1.65 or 1.8	1.8	3	125 x 100	25	1875	MBW 244I5	63.46	48.88
CORNER	2440	8'	1.65 or 1.8	1.8	3	100 x 100	6	360	MBW 244C4	62.62	48.15
	2440	8'	1.65 or 1.8	1.8	3	125 x 100	6	450	MBW 244C5	73.41	56.48

CLOSEBOARD

For added security, privacy and long-term value, a closeboard fence is also a popular choice. Ibstock manufactures both recessed and morticed concrete posts suitable for all applications.

All Ibstock posts are manufactured to a very high standard with clear, definitive mortices or recesses to allow for ease of installation and enhanced appearance. The appearance of the fence is determined by the choice of posts: morticed posts (shown below, right) and recessed posts (shown below, left) are both used in conjunction with aris rails, featheredge boards and Ibstock gravel boards.



Rail guidance: the recommended number of rails depends upon the fence height – always check site exposure and location, as more may be required for greater wind resistance.

FENCE HEIGHT	NO.
Below 7'	2
7'1" to 9'8"	3
9'9" to 11'	4

Recessed posts

Available as Istock Standard range and British Standard.

SUPREME STYLE RECESSED POSTS INCLUDES HOLES FOR EASE OF ATTACHING GRAVEL BOARDS											
TYPE	METRIC (MM)	IMPERIAL	FENCE HEIGHT		RAILS	DIMENSIONS (MM)	PACK QUANTITY	PACK WEIGHT (KG)	PRODUCT CODE	SPLIT PRICE EACH (£)	PACK PRICE EACH (£)
			NO GRAVEL BOARD	GRAVEL BOARD (150MM HIGH)							
INTERMEDIATE	1450	4'9"	0.75	0.9	2	125 > 100 x 110	25	1100	REC 145I	43.94	33.75
	1525	5'	0.9	1.05	2	125 > 100 x 110	25	1110	REC 152I	45.83	35.25
	1830	6'	1.05	1.2	2	125 > 100 x 110	25	1375	REC 183I	49.78	38.33
	2210	7'3"	1.35	1.5	2	125 > 100 x 110	25	1675	REC 221I	51.66	39.65
	2515	8'3"	1.65	1.8	3	125 > 100 x 110	25	1835	REC 251I	53.28	40.95
CORNER	3350	11'1"	1.8	2.4	4	125 > 100 x 110	15	1680	REC 335I	83.23	63.98
	1450	4'9"	0.75	0.9	2	140 x 140 > 115 x 115	6	339	REC 145C	51.25	39.55
	1525	5'	0.9	1.05	2	140 x 140 > 115 x 115	6	345	REC 152C	52.82	40.58
	1830	6'	1.05	1.2	2	140 x 140 > 115 x 115	6	400	REC 183C	66.16	50.94
	2210	7'3"	1.35	1.5	2	140 x 140 > 115 x 115	6	480	REC 221C	70.75	54.34
2515	8'3"	1.65	1.8	3	140 x 140 > 115 x 115	6	550	REC 251C	74.46	57.26	

BS 1722-5 RECESSED POSTS ADJUSTED FOR GRAVEL BOARD											
TYPE	METRIC (MM)	IMPERIAL	FENCE HEIGHT WITH GRAVEL BOARD (150MM HIGH)	RAILS	DIMENSIONS (MM)	PACK QUANTITY	PACK WEIGHT (KG)	PRODUCT CODE	SPLIT PRICE EACH (£)	PACK PRICE EACH (£)	
											INTERMEDIATE
1750	5'9"	1.2	2	140 > 100 x 115	25	1463	RGB 175I	57.35	44.15		
2200	7'3"	1.5	3	140 > 100 x 115	25	1838	RGB 220I	61.57	47.39		
2350	7'9"	1.65	3	140 > 100 x 115	25	1963	RGB 235I	64.87	49.90		
2500	8'3"	1.8	3	140 > 100 x 115	25	2088	RGB 250I	66.58	51.16		
CORNER	1600	5'3"	1.05	2	140 x 140 > 115 x 115	6	378	RGB 160C	66.58	51.16	
	1750	5'9"	1.2	2	140 x 140 > 115 x 115	6	411	RGB 175C	69.84	53.70	
	2200	7'3"	1.5	3	140 x 140 > 115 x 115	6	516	RGB 220C	74.08	56.91	
	2350	7'9"	1.65	3	140 x 140 > 115 x 115	6	552	RGB 235C	77.43	59.54	
	2500	8'3"	1.8	3	140 x 140 > 115 x 115	6	585	RGB 250C	79.05	60.72	

BS 1722-5 RECESSED POSTS NO GRAVEL BOARD											
TYPE	METRIC (MM)	IMPERIAL	FENCE HEIGHT WITH GRAVEL BOARD (150MM HIGH)	RAILS	DIMENSIONS (MM)	PACK QUANTITY	PACK WEIGHT (KG)	PRODUCT CODE	SPLIT PRICE EACH (£)	PACK PRICE EACH (£)	
											INTERMEDIATE
1750	5'9"	1.2	2	140 > 100 x 115	25	1463	RBS 175I	57.35	44.15		
2200	7'3"	1.5	3	140 > 100 x 115	25	1838	RBS 220I	61.57	47.39		
2350	7'9"	1.65	3	140 > 100 x 115	25	1963	RBS 235I	64.87	49.90		
2500	8'3"	1.8	3	140 > 100 x 115	25	2088	RBS 250I	66.58	51.16		
CORNER	1600	5'3"	1.05	2	140 x 140 > 115 x 115	6	378	RBS 160C	66.58	51.16	
	1750	5'9"	1.2	2	140 x 140 > 115 x 115	6	411	RBS 175C	69.84	53.70	
	2200	7'3"	1.5	3	140 x 140 > 115 x 115	6	516	RBS 220C	74.08	56.91	
	2350	7'9"	1.65	3	140 x 140 > 115 x 115	6	552	RBS 235C	77.43	59.54	
	2500	8'3"	1.8	3	140 x 140 > 115 x 115	6	585	RBS 250C	79.05	60.72	

BS British Standard posts have a wider profile for greater strength. They are often specified for local authority and public projects.

Gravel boards

These have been designed with a smooth finish to suit both morticed and recessed posts. The gravel boards can be easily installed using Istock's specially designed fixer or cleat system.



GRAVEL BOARDS FOR MORTICED AND RECESSED POSTS							
*PLEASE NOTE THE IMPERIAL MEASUREMENTS INCLUDE SOME ROUNDING UP TO THE NEAREST 1/2 INCH							
TYPE	DIMENSIONS (MM)	IMPERIAL	PACK QUANTITY	PACK WEIGHT (KG)	PRODUCT CODE	SPLIT PRICE EACH (£)	PACK PRICE EACH (£)
NATURAL FINISH	1900 x 150 x 50	6'3"	20	700	GBL 19015	32.76	25.24
	2285 x 150 x 50	7'6"	20	823	GBL 22815	35.86	29.36
	2400 x 150 x 50	7'10"	20	871	GBL 24015	38.97	29.93
	2590 x 150 x 50	8'5"	20	900	GBL 25915	41.76	32.14
	2700 x 150 x 50	8'10"	20	920	GBL 27015	42.64	32.78
	2745 x 150 x 50	9'	20	950	GBL 27415	43.34	33.31
	2885 x 150 x 50	9'5"	20	984	GBL 28815	46.46	35.71
	3000 x 150 x 50	9'10"	20	1020	GBL 30015	50.23	38.68
	2700 x 200 x 50	8'10"	10	630	GBL 27020	56.56	43.53
	2745 x 200 x 50	9'	10	650	GBL 27420	57.61	44.35
	2885 x 200 x 50	9'5"	10	665	GBL 28820	60.65	46.73
	3000 x 200 x 50	9'10"	10	685	GBL 30020	64.66	49.66

GRAVEL BOARD FIXER						
DIMENSIONS (MM)	IMPERIAL	PACK QUANTITY	PACK WEIGHT (KG)	PRODUCT CODE	SPLIT PRICE EACH (£)	PACK PRICE EACH (£)
380 x 100 x 65	15" x 4" x 2.5"	40	180	GBF 150	8.41	6.49

GRAVEL BOARD FIXER

Istock's unique gravel board fixer has been designed to make the installation of gravel boards with morticed posts quick and easy. Simply locate the gravel board fixer into the base of the post using the holes provided. The gravel board can then be slotted into the fixer for a secure and flush finish.

Gravel board

Gravel board fixer for morticed posts

WHY STRONGCAST PROFESSIONAL™

As the market leaders in fencing in the UK, we always take great pride in our product development and innovation, our best ideas always coming from listening to our customers. Domestic fencing solutions haven't changed for several years now. Thanks to natural improvements in aggregates, plasticisers and mixing technology, together with our investments in manufacturing capability, it seemed natural that the next step for us was to survey the market and develop one of our lead product ranges.

We found a real appetite from you, the professionals, for an improved, next generation fencing solution.

Istock's new Strongcast Professional range continues to be best in class for its finish, quality, weight, strength and functionality. Istock are on a continuous improvement journey and will continue to deliver best in class products.

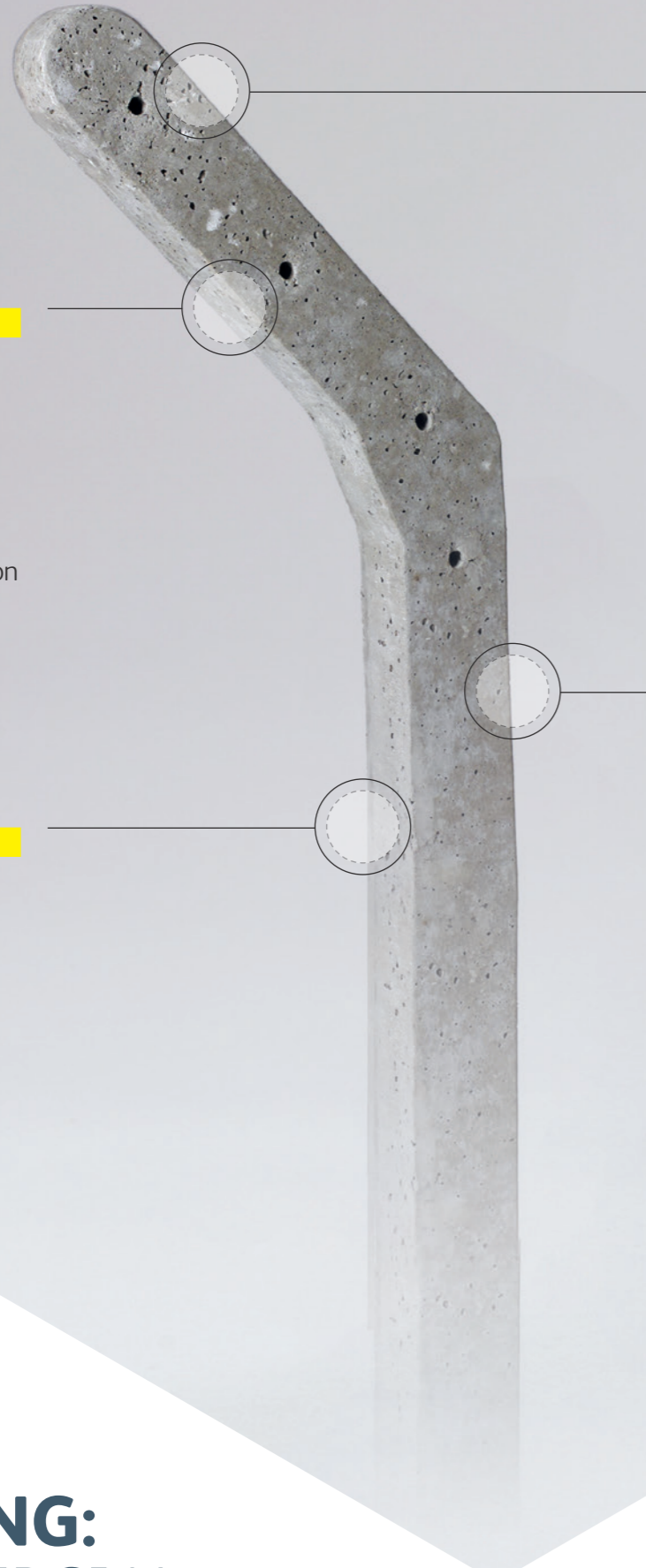

LONG LIFE AND DURABLE

Completely resistant to moisture and rot

COMPREHENSIVE RANGE

- British Standard options available
- Full range of strainer, struts and gateposts to complement posts
- Cost-effective high security fencing solution



SUPERIOR STRENGTH

- When compared to wet cast alternative
- Less susceptible to damage during transportation, handling and installation

UKCA MARKED

For your assurance



**FENCING:
COMMERCIAL**

**STRONGCAST
ORIGINAL™
CRANKED TOP
CHAINLINK POST**

Ibstock's range of posts for security and perimeter fencing is one of the widest available in the UK and has been used in some of the country's most sensitive installations.



STRONGCAST ORIGINAL™

FEATURES AND BENEFITS

This is a unique process, using a special semi-dry concrete, which is compacted by vibration to give high strength and durability.

All posts and gravel boards are steel reinforced for extra strength and long life. **STRONGCAST ORIGINAL™** products are completely unaffected by moisture or rot. Products have a slightly more textured appearance than wet-cast concrete.



Gain more, stock core products

There's never a better time to increase sales, and an easy way is to stock the right range.

FENCING PRODUCT	PRODUCT CODE	BEST SELLERS	DEVELOP YOUR RANGE
Chainlink	CHK 145I (4'9")	✓	✓
	CHK 251I (8'3")	✓	✓
	CHK 190I (6'3")	✓	✓
	CHK 145E (4'9")		✓
	CHK 190E (6'3")		✓
Universal post	UNI 244IP (8')	✓	✓
	UNI 183IP (6')		✓
	UNI 275IP (9')		✓

Commercial benefits

For commercial applications we have developed a range of concrete posts for use with chainlink or weld mesh to provide a cost-effective method of protecting any premises.

- One of the widest available range of commercial posts in the UK
- Ideal for sensitive installations
- Full range includes strainers, struts and gate posts
- Backed by a wealth of experience, each size, section and specification has been designed for a specific need



British Standard sizes available



What do we sell?

- Chainlink posts
- Gate posts
- Cranked top posts
- Straight top posts
- Strained wire posts
- Concrete panel
- Walling system
- Universal posts
- Barrel rail posts
- Clothes line posts

Chainlink posts

Concrete posts with chainlink or weld mesh provide a cost-effective method of protecting any premises. Ibstock's range of posts for security and perimeter fencing is one of the widest available in the UK.

STRONGCAST ORIGINAL™ CHAINLINK POSTS									
WIRE HEIGHT	METRIC (MM)	IMPERIAL	DIMENSIONS (MM)	DESCRIPTION	PACK QUANTITY	PACK WEIGHT (KG)	PRODUCT CODE	SPLIT PRICE EACH (£)	PACK PRICE EACH (£)
0.9M	1450	4'9"	100 > 75	Intermediate	36	968	CHK 145I	25.21	19.39
	1450	4'9"	100 x 100	End	12	420	CHK 145E	34.82	26.82
	1450	4'9"	100 x 100	Two Way	12	420	CHK 145T	34.82	26.82
	1450	4'9"	100 x 100	Corner	12	420	CHK 145C	34.82	26.82
	1525	5'2"	75 x 75	Strut	24	480	CHK 152S	29.27	22.47
1.05M	1750	5'9"	100 > 75	Intermediate	36	1152	CHK 175I	30.41	23.40
	1750	5'9"	100 x 100	End	12	504	CHK 175E	39.64	30.46
	1750	5'9"	100 x 100	Two Way	12	504	CHK 175T	39.64	30.46
	1750	5'9"	100 x 100	Corner	12	504	CHK 175C	39.64	30.46
	1830	6'	75 x 75	Strut	24	559	CHK 183S	32.76	25.21
1.2M	1905	6'3"	100 > 75	Intermediate	36	1238	CHK 190I	31.65	24.31
	1905	6'3"	100 > 75	Intermediate with Side Holing	36	1238	CHK 190IS	31.65	24.31
	1905	6'3"	100 x 100	End	12	550	CHK 190E	40.87	31.31
	1905	6'3"	100 x 100	Two Way	12	550	CHK 190T	40.87	31.31
	1905	6'3"	100 x 100	Corner	12	550	CHK 190C	40.87	31.31
	1830	6'	75 x 75	Strut	24	559	CHK 183S	32.76	25.21
1.4M	2060	6'9"	100 > 75	Intermediate	36	1260	CHK 206I	34.46	26.52
	2060	6'9"	100 x 100	End	12	594	CHK 206E	47.97	36.93
	2060	6'9"	100 x 100	Two Way	12	594	CHK 206T	47.97	36.93
	2060	6'9"	100 x 100	Corner	12	594	CHK 206C	47.97	36.93
	2130	7'	100 x 85	Strut	24	1020	CHK 213S	38.40	29.57
1.5M	2210	7'3"	125 > 75	Intermediate	18	954	CHK 221I	46.04	35.41
	2210	7'3"	125 x 125	End	12	996	CHK 221E	72.05	55.43
	2210	7'3"	125 x 125	Two Way	12	996	CHK 221T	72.05	55.43
	2210	7'3"	125 x 125	Corner	12	996	CHK 221C	72.05	55.43
	2130	7'	100 x 85	Strut	24	1020	CHK 213S	38.40	29.57
1.8M	2460	8'1"	125 > 75	Intermediate	18	994	CHK 246I	46.04	35.41
	2460	8'1"	125 > 75	Intermediate with Side Holing	18	994	CHK 246IS	46.04	35.41
1.8M	2515	8'3"	100 > 75	Intermediate	36	1674	CHK 251I	43.58	33.55
	2515	8'3"	100 x 100	End	12	720	CHK 251E	57.26	44.01
	2515	8'3"	100 x 100	Two Way	12	720	CHK 251T	57.26	44.01
	2515	8'3"	100 x 100	Corner	12	720	CHK 251C	57.26	44.01
	2590	8'5"	100 x 85	Strut	24	1219	CHK 259S	47.18	36.21
2.1M	2970	9'7"	125 > 75	Intermediate	18	1296	CHK 297I	62.14	47.75
	2970	9'7"	125 x 125	End	12	1344	CHK 297E	103.25	79.44
	2970	9'7"	125 x 125	Two Way	12	1344	CHK 297T	103.25	79.44
	2970	9'7"	125 x 125	Corner	12	1344	CHK 297C	103.25	79.44
	2900	9'5"	100 x 85	Strut	12	720	CHK 290S	53.28	40.95
2.4M	3220	10'7"	125 > 75	Intermediate	18	1476	CHK 322I	73.30	56.35
	3220	10'7"	125 > 75	Intermediate with Side Holing	18	1476	CHK 322IS	73.30	56.35
	3220	10'7"	125 x 125	End	12	1452	CHK 322E	134.43	103.38
	3220	10'7"	125 x 125	Two Way	12	1452	CHK 322T	134.43	103.38
	3220	10'7"	125 x 125	Corner	12	1452	CHK 322C	134.43	103.38
	3350	11'	100 x 100	Strut	12	970	CHK 335S	75.77	58.19
	3350	11'	100 x 100	Birds Mouth Strut	12	970	CHK 335SB	84.05	64.71

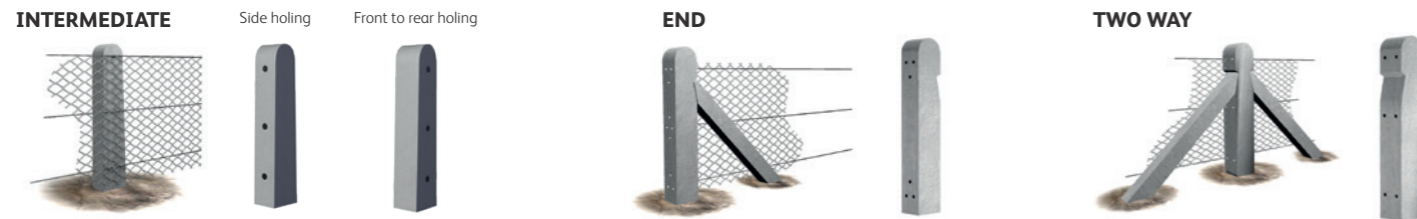

CORNER

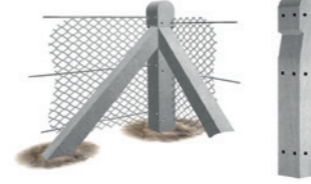

ENDS AND GATE POSTS ARE DOUBLE HOLED FOR LEFT AND RIGHT ENDS

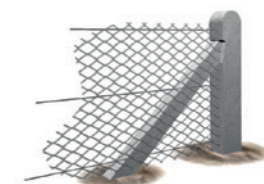

BS 1722-1 CHAINLINK POST

WIRE HEIGHT	METRIC (MM)	IMPERIAL	DIMENSIONS (MM)	DESCRIPTION	PACK QUANTITY	PACK WEIGHT (KG)	PRODUCT CODE	SPLIT PRICE EACH (£)	PACK PRICE EACH (£)
0.9M	1570	5'2"	100 > 75	Intermediate	36	1048	CHK 157I	27.59	21.24
	1570	5'2"	100 > 75	Intermediate with Side Holing	36	1048	CHK 157IS	27.59	21.24
	1570	5'2"	100 x 100	End	12	456	CHK 157E	36.86	28.40
	1570	5'2"	100 x 100	Two Way	12	456	CHK 157T	36.86	28.40
	1570	5'2"	100 x 100	Corner	12	456	CHK 157C	36.86	28.40
1.2M	1870	6'1"	125 > 75	Intermediate	18	785	CHK 187I	35.55	27.47
	1870	6'1"	125 > 75	Intermediate with Side Holing	18	785	CHK 187IS	35.55	27.47
	1870	6'1"	125 x 125	End	12	828	CHK 187E	56.46	43.43
	1870	6'1"	125 x 125	Two Way	12	828	CHK 187T	56.46	43.43
	1870	6'1"	125 x 125	Corner	12	828	CHK 187C	56.46	43.43
1.4M	2070	6'9"	125 > 75	Intermediate	18	904	CHK 207I	41.25	31.74
	2070	6'9"	125 > 75	Intermediate with Side Holing	18	904	CHK 207IS	41.25	31.74
	2070	6'9"	125 x 125	End	12	940	CHK 207E	63.15	48.60
	2070	6'9"	125 x 125	Two Way	12	940	CHK 207T	63.15	48.60
	2070	6'9"	125 x 125	Corner	12	940	CHK 207C	63.15	48.60
1.8M	2620	8'7"	125 > 75	Intermediate	18	1129	CHK 262I	49.96	38.49
	2620	8'7"	125 > 75	Intermediate with Side Holing	18	1129	CHK 262IS	49.96	38.49
	2620	8'7"	125 x 125	End	12	1140	CHK 262E	75.77	58.19
	2620	8'7"	125 x 125	Two Way	12	1140	CHK 262T	75.77	58.19
	2620	8'7"	125 x 125	Corner	12	1140	CHK 262C	75.77	58.19
2.4M	2590	8'5"	100 x 85	Strut	24	1219	CHK 259S	47.18	36.21
	2590	8'5"	100 x 85	Birds Mouth Strut	24	1219	CHK 259SB	47.18	36.21

CHAINLINK GATEPOST

WIRE HEIGHT	METRIC (MM)	IMPERIAL	DIMENSIONS (MM)	PACK QUANTITY	PACK WEIGHT (KG)	PRODUCT CODE	SPLIT PRICE EACH (£)	PACK PRICE EACH (£)
0.9M	1570	5'2"	125 x 125	4	240	CHG 157G5	58.76	45.25
	1570	5'2"	150 x 150	4	360	CHG 157G6	75.77	58.19
1.4M	2070	6'9"	125 x 125	4	316	CHG 207G5	75.27	57.84
	2070	6'9"	150 x 150	4	448	CHG 207G6	112.02	86.22
1.5M	2210	7'3"	125 x 125	4	332	CHG 213G5	81.60	62.91
	2210	7'3"	150 x 150	4	484	CHG 213G6	118.96	91.42
2.1M	2970	9'7"	125 x 125	4	448	CHG 297G5	114.06	87.81
	2970	9'7"	150 x 150	4	640	CHG 297G6	176.13	135.39
2.4M	3220	10'7"	150 x 150	4	696	CHG 322G6	184.81	142.08

CHAINLINK GATEPOST

WIRE HEIGHT	METRIC (MM)	IMPERIAL	DIMENSIONS (MM)	PACK QUANTITY	PACK WEIGHT (KG)	PRODUCT CODE	SPLIT PRICE EACH (£)	PACK PRICE EACH (£)
1.2M	1870	6'1"	125 x 125	4	284	CHG 187G5	69.97	53.81
	1870	6'1"	150 x 150	4	404	CHG 187G6	100.41	77.20
1.8M	2620	8'7"	125 x 125	4	400	CHG 262G5	91.63	70.53
	2620	8'7"	150 x 150	4	568	CHG 262G6	140.43	108.04



British Standard posts have a wider profile for greater strength. They are often specified for local authority and public projects.

Chainlink fence posts

CHAINLINK CRANKED TOP POSTS

Cranked top posts offer additional security with the ability to provide anti-climb protection.

CHAINLINK CRANKED TOP POST										
WIRE HEIGHT	METRIC (MM)	IMPERIAL	DIMENSIONS (MM)	DESCRIPTION	PACK QUANTITY	PACK WEIGHT (KG)	PRODUCT CODE (HEAD IN)	PRODUCT CODE (HEAD OUT)	SPLIT PRICE EACH (£)	PACK PRICE EACH (£)
1.8M FOR 3 ROWS OF WIRE BS 1722-1	3125	10'3"	125 > 75	Intermediate	18	1319	CHC 312I	—	58.37	44.91
	3125	10'3"	125 x 125	End Left	12	1420	CHC 312EW	CHC 312EX	100.83	77.57
	3125	10'3"	125 x 125	End Right	12	1420	CHC 312EX	CHC 312EW	100.83	77.57
	3125	10'3"	125 x 125	Two Way	12	1420	CHC 312T	—	100.83	77.57
	3125	10'3"	125 x 125	Corner External	12	1420	CHC 312CV	CHC 312CZ	100.83	77.57
	3125	10'3"	125 x 125	Corner Internal	12	1420	CHC 312CZ	CHC 312CV	100.83	77.57
	2590	8'5"	100 x 85	Strut	24	1219	CHK 259S	—	47.18	36.21
2590	8'5"	100 x 85	Birds Mouth Strut	24	1219	CHC 259SB	—	55.55	42.85	
2.0/2.1M FOR 3 ROWS OF WIRE	3350	11'	125 > 75	Intermediate	18	1458	CHC 335I	—	75.77	58.19
	3350	11'	125 x 125	End Left	12	1536	CHC 335EW	CHC 335EX	124.44	95.72
	3350	11'	125 x 125	End Right	12	1536	CHC 335EX	CHC 335EW	124.44	95.72
	3350	11'	125 x 125	Two Way	12	1536	CHC 335T	—	124.44	95.72
	3350	11'	125 x 125	Corner External	12	1536	CHC 335CV	CHC 335CZ	124.44	95.72
	3350	11'	125 x 125	Corner Internal	12	1536	CHC 335CZ	CHC 335CV	124.44	95.72
	2900	9'5"	100 x 85	Strut	12	720	CHK 290S	—	53.28	40.95
2900	9'5"	100 x 85	Birds Mouth Strut	12	720	CHC 290SB	—	61.57	47.39	
2.4M FOR 3 ROWS OF WIRE BS 1722-10	3730	12'3"	125 > 85 x 100	Intermediate	16	1760	CHC 373I	—	83.61	64.35
	3730	12'3"	150 x 150	End Left	6	1200	CHC 373EW	CHC 373EX	155.58	119.71
	3730	12'3"	150 x 150	End Right	6	1200	CHC 373EX	CHC 373EW	155.58	119.71
	3730	12'3"	150 x 150	Two Way	6	1200	CHC 373T	—	155.58	119.71
	3730	12'3"	150 x 150	Corner External	3	613	CHC 373CV	CHC 373CZ	155.58	119.71
	3730	12'3"	150 x 150	Corner Internal	3	613	CHC 373CZ	CHC 373CV	155.58	119.71
	3350	11'	100 x 100	Strut	12	970	CHK 335S	—	75.77	58.19
3350	11'	100 x 100	Birds Mouth Strut	12	970	CHC 335SB	—	84.05	64.71	

CRANKED TOP POST



Position of struts for cranked top and strainer posts

- External/internal obtuse corners – use 2-way post with one plain and one birdsmouth strut
- All strainer posts are double holed for head IN or OUT
- End and corner posts are handed because of strut recesses
- Gate posts have straight extension and are double holed for either end

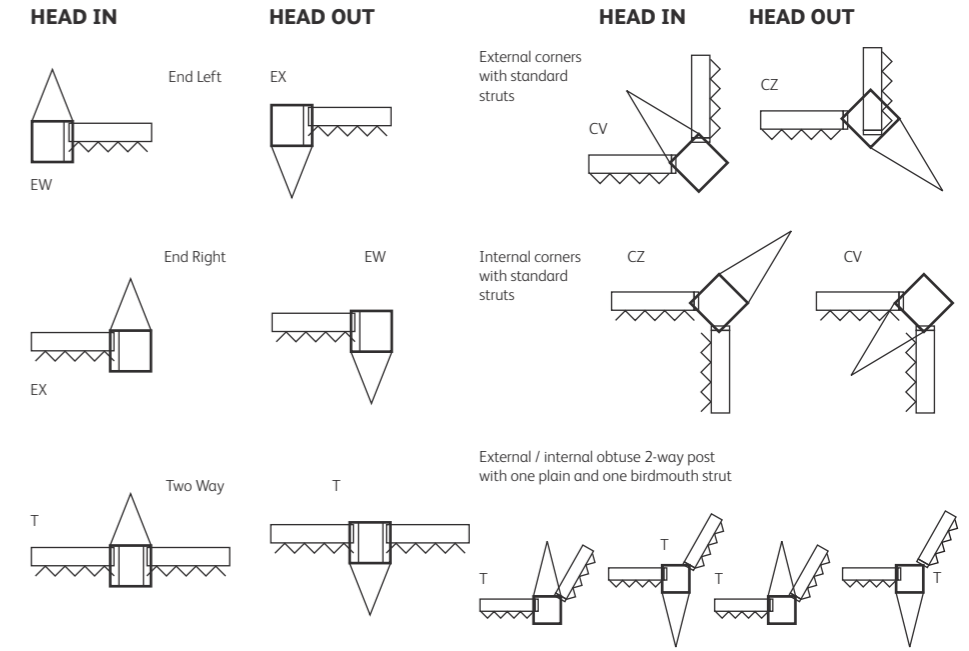

STRAIGHT EXTENDED TOP POST

For maximum protection our extended height posts allow for three additional rows of wire.

CHAINLINK STRAIGHT EXTENDED TOP POST										
INTERMEDIATES WITH SIDE HOLING										
WIRE HEIGHT	METRIC (MM)	IMPERIAL	DIMENSIONS (MM)	DESCRIPTION	PACK QUANTITY	PACK WEIGHT (KG)	PRODUCT CODE	SPLIT PRICE EACH (£)	PACK PRICE EACH (£)	
1.8M FOR 3 ROWS OF WIRE BS 1722-1	2970	9'7"	125 > 75	Intermediate with side holing	20	1390	CHS 304I	58.37	44.91	
	2970	9'7"	125 x 125	End	12	1320	CHS 304E	100.83	77.57	
	2970	9'7"	125 x 125	Two way	12	1320	CHS 304T	100.83	77.57	
	2970	9'7"	125 x 125	Corner	12	1320	CHS 304C	100.83	77.57	
	2590	8'5"	100 x 85	Strut	24	1219	CHK 259S	47.18	36.21	
2.0/2.1M FOR 3 ROWS OF WIRE	3350	11'	125 > 75	Intermediate	18	1458	CHS 335I	75.77	58.19	
	3350	11'	125 x 125	End	12	1512	CHS 335E	124.44	95.72	
	3350	11'	125 x 125	Two way	12	1512	CHS 335T	124.44	95.72	
	3350	11'	125 x 125	Corner	12	1512	CHS 335C	124.44	95.72	
	2900	9'5"	100 x 85	Strut	12	720	CHK 290S	53.28	40.95	
2.4M FOR 3 ROWS OF WIRE BS 1722-10	3655	12'	125 x 100	Intermediate with side holing	16	1294	CHS 373I	81.21	62.48	
	3655	12'	150 x 150	End	6	1185	CHS 373E	155.58	119.71	
	3655	12'	150 x 150	Two way	6	1185	CHS 373T	155.58	119.71	
	3655	12'	150 x 150	Corner	6	1185	CHS 373C	155.58	119.71	
	3350	11'	100 x 100	Strut	12	970	CHK 335S	75.77	58.19	

CHAINLINK STRAIGHT EXTENDED TOP GATE POST

WIRE HEIGHT	METRIC (MM)	IMPERIAL	DIMENSIONS (MM)	DESCRIPTION	PACK QUANTITY	PACK WEIGHT (KG)	PRODUCT CODE	SPLIT PRICE EACH (£)	PACK PRICE EACH (£)
1.8M BS 1722-1	3125	10'3"	125 x 125	Gate straight	4	452	CHG 312G5	111.69	85.79
	3125	10'3"	150 x 150	Gate straight	4	644	CHG 312G6	171.69	132.06
	3125	10'3"	200 x 200	Gate straight	4	1160	CHG 312G8	326.09	250.76
2.0/2.1M	3350	11'	125 x 125	Gate straight	4	504	CHG 335G5	148.85	114.48
	3350	11'	150 x 150	Gate straight	4	724	CHG 335G6	193.19	148.59
2.4M BS 1722-10	3730	12'3"	150 x 150	Gate straight	4	820	CHG 373G6	205.67	158.13
	3730	12'3"	200 x 200	Gate straight	4	1500	CHG 373G8	439.23	337.84

Strained wire posts

Posts contain multiple line wire spacings to meet a range of commercial applications.

BS 1722-2 STRAINED WIRE POST									
WIRE	METRIC (MM)	IMPERIAL	DIMENSIONS (MM)	DESCRIPTION	PACK QUANTITY	PACK WEIGHT (KG)	PRODUCT CODE	SPLIT PRICE EACH (£)	PACK PRICE EACH (£)
SC90 3 WIRES	1570	5'2"	100 > 75	Intermediate	36	1044	SWA 160I	31.21	24.08
	1570	5'2"	100 x 100	End	12	456	SWA 160E	36.86	28.40
	1570	5'2"	100 x 100	Two Way	12	456	SWA 160T	36.86	28.40
	1570	5'2"	100 x 100	Corner	12	456	SWA 160C	36.86	28.40
	1525	5'2"	75 x 75	Strut	24	480	CHK 152S	29.27	22.47
SC105 A/B 6 WIRES	1720	5'8"	100 > 75	Intermediate	36	1152	SWA 172I	34.46	26.52
	1870	6'2"	125 x 125	End	12	852	SWA 187E	61.22	47.09
	1870	6'2"	125 x 125	Two Way	12	852	SWA 187T	61.22	47.09
	1870	6'2"	125 x 125	Corner	12	852	SWA 187C	61.22	47.09
	1870	6'2"	100 x 75	Strut	24	878	SWA 187S	34.10	26.19
SC120 6 WIRES	1870	6'1"	125 > 75	Intermediate	36	1620	SWA 187I	35.55	27.47
	2020	6'7"	125 x 125	End	12	924	SWA 202E	67.27	51.79
	2020	6'7"	125 x 125	Two Way	12	924	SWA 202T	67.27	51.79
	2020	6'7"	125 x 125	Corner	12	924	SWA 202C	67.27	51.79
	2135	7'	100 x 75	Strut	24	1008	SWA 213S	38.42	29.57
SC135 A/B 8 WIRES	2020	6'7"	125 > 75	Intermediate	36	1764	SWA 202I	38.42	29.57
	2170	7'1"	125 x 125	End	12	996	SWA 217E	72.05	55.43
	2170	7'1"	125 x 125	Two Way	12	996	SWA 217T	72.05	55.43
	2170	7'1"	125 x 125	Corner	12	996	SWA 217C	72.05	55.43
2135	7'	100 x 75	Strut	24	1008	SWA 213S	38.42	29.57	



Concrete panel walling system

The system provides a quick to build and economical walling solution for security, privacy and noise reduction.

HEAVY DUTY SLOTTED POSTS										
WALL HEIGHT	METRIC (MM)	IMPERIAL	DIMENSIONS (MM)	PANELS PER BAY	DESCRIPTION	PACK QUANTITY	PACK WEIGHT (KG)	PRODUCT CODE	SPLIT PRICE EACH (£)	PACK PRICE EACH (£)
2.1M	9'6"	2900	125 x 130	7	Intermediate	20	1780	HWS 290I	92.45	71.05
	9'6"	2900	125 x 130	7	End	6	610	HWS 290E	92.45	71.05
	9'	2745	125 x 125	7	Corner	6	530	SLT 274C	79.27	61.01
2.4M	10'6"	3200	125 x 130	8	Intermediate	12	1339	HWS 320I	102.48	78.75
	10'6"	3200	125 x 130	8	End	6	755	HWS 320E	102.48	78.75
	10'6"	3200	125 x 125	8	Corner	6	640	SLT 320C	117.64	90.44

CONCRETE PANEL WALLING SYSTEM							
IMPERIAL	DIMENSIONS (MM)	DESCRIPTION	PACK QUANTITY	PACK WEIGHT (KG)	PRODUCT CODE	SPLIT PRICE EACH (£)	PACK PRICE EACH (£)
1925 x 300 x 50	12"	Weatherboard reverse as cast	20	1180	WAL 192	42.92	35.60
1830 x 305 x 50	12"	Rock faced reverse as cast	15	860	GBROC 305	36.51	30.46
1830 x 305 x 50	12"	Smooth faced reverse as cast	20	1220	GBS 305	35.04	29.25

Miscellaneous posts

POSTS

The range features unique posts such as the easy to use universal posts for strained wire and chainlink, through to barrel rail posts and traditional clothes line post.

UNIVERSAL POST									
METRIC (MM)	IMPERIAL	DIMENSIONS (MM)	DESCRIPTION	PACK QUANTITY	PACK WEIGHT (KG)	PRODUCT CODE	SPLIT PRICE EACH (£)	PACK PRICE EACH (£)	
1525	5'	100 x 100	Intermediate	36	1274	UNI 152IP	38.42	29.57	
1525	5'	125 x 125	3 way strainer	6	325	UNI 152S	56.84	43.67	
1525	5'	75 x 75	Strut 1525	24	480	CHK 152S	29.27	22.47	
1830	6'	100 x 100	Intermediate	36	1544	UNI 183IP	43.43	33.49	
1830	6'	125 x 125	3 way strainer	6	410	UNI 183S	65.16	50.11	
1830	6'	75 x 75	Strut 1830	24	559	CHK 183S	32.76	25.21	
2130	7'	100 x 100	Intermediate	36	1793	UNI 213IP	49.22	37.89	
2130	7'	125 x 125	3 way strainer	6	460	UNI 213S	73.41	56.48	
2130	7'	100 x 85	Strut 2130	24	1020	CHK 213S	38.40	29.57	
2440	8'	100 x 100	Intermediate	36	2045	UNI 244IP	51.79	39.80	
2440	8'	125 x 125	3 way strainer	6	540	UNI 244S	82.03	63.01	
2590	8'6"	100 x 85	Strut 2590	24	1219	CHK 259S	47.18	36.21	
2750	9'	100 x 100	Intermediate	36	2329	UNI 275IP	59.71	45.92	
2750	9'	125 x 125	3 way strainer	6	610	UNI 275S	90.15	69.32	
2590	8'6"	100 x 85	Strut 2590	24	1219	CHK 259S	47.18	36.21	

BARREL RAIL POST 150MM X 100MM							
METRIC (MM)	IMPERIAL	DESCRIPTION	PACK QUANTITY	PACK WEIGHT (KG)	PRODUCT CODE	SPLIT PRICE EACH (£)	PACK PRICE EACH (£)
1500	5'	1 hole	24	1248	BAR 152H1	74.67	57.40
1500	5'	2 holes	24	1248	BAR 152H2	74.67	57.40
1800	6'	1 hole	24	1500	BAR 180H1	89.78	69.11
1800	6'	2 holes	24	1500	BAR 180H2	89.78	69.11

UNIVERSAL POSTS

Holed every 150mm

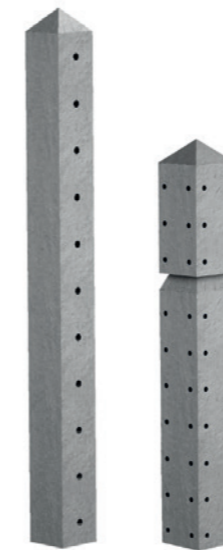

BARREL RAIL POST

Holed for 60mm rails

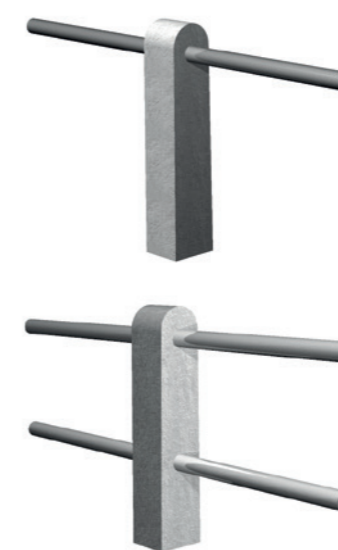

BS British Standard sizes available

UK CA Declaration of performance www.supreme-ce.co.uk

POPULAR PRODUCTS

Popular products include options with and without water drip grooves. Available in buff and natural grey colours



HIGH QUALITY

High quality concrete mix ensures long term durability

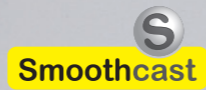

SMOOTHCAST

High quality raw materials and precision moulding technology creates an attractive smooth finish

High quality, good design and great value are the hallmarks of the range that features a wide variety of essential building products for refurbishment, new build housing and commercial projects. **These include wall copings, inspection chambers, window sills and door steps.**

Building products

Innovative precasting technology has enabled Ibstock to develop a range of essential building components.

BENEFITS

- Decorative and protective
- Durable and easy to install
- Cost-effective
- Quality design
- Precision moulding technology
- Bespoke manufacturing enquiry service available

Gain more, stock core products

There's never a better time to increase sales, and an easy way is to stock the right range.

BUILDING PRODUCT	PRODUCT CODE	BEST SELLERS	DEVELOP YOUR RANGE
Caps and copings	COP 121 (12" x 24")	✓	✓
Twice weathered	COP 126 (14" x 24")	✓	✓
	COP 111 (6 1/2" x 24")	✓	✓
	COP 106 (5" x 24")		✓
	COP 131 (16" x 36")		✓
	COP 116 (8 3/4" x 24")		✓
Caps and copings	COP 216 (14" x 24")	✓	✓
Once weathered	COP 221 (16" x 36")	✓	✓
	COP 211 (12" x 24")	✓	✓
	COP 201 (6 1/2" x 24")		✓
Pier caps	CAP 07 (16" x 16")	✓	✓
	CAP 14 (12" x 12")	✓	✓



What do we sell?

- Pier caps
- Twice weathered copings
- Once weathered copings
- Flat copings
- Buff copings
- Chimney caps
- Window sills
- Gully surrounds
- Door steps
- Inspection chambers

BUILDING PRODUCTS

SMOOTHCAST™ TWICE WEATHERED COPINGS

Caps and copings

PIER CAPS AND COPINGS

The copings are manufactured in three popular styles; flat, once weathered which sheds surface water in one direction and twice weathered which directs it away in two directions.

4 WAY WEATHERED PIER CAPS								
TYPE	METRIC (MM)	IMPERIAL	DESCRIPTION	PACK QUANTITY	PACK WEIGHT (KG)	PRODUCT CODE	SPLIT PRICE EACH (£)	PACK PRICE EACH (£)
WATER-DRIP GROOVES (UNLESS OTHERWISE STATED)	220 x 220	8 5/8" x 8 5/8"	No drip	60	312	CAP 01S	7.39	6.72
	220 x 335	8 5/8" x 13 1/4"	No drip	60	600	CAP 03	11.99	10.96
	280 x 280	11" x 11"	—	60	540	CAP 02	8.04	7.26
	280 x 380	11" x 15"	—	30	420	CAP 04	19.48	16.27
	305 x 305	12" x 12"	—	30	336	CAP 14	11.04	10.02
	330 x 330	13" x 13"	No drip	30	438	CAP 05	15.53	12.94
	380 x 380	15" x 15"	No drip	45	1017	CAP 15	16.06	13.39
	405 x 405	16" x 16"	—	15	339	CAP 07	16.09	13.53
	405 x 530	16" x 21"	—	10	308	CAP 08	36.38	30.36
	455 x 455	18" x 18"	No drip	10	320	CAP 10	24.21	20.24
	530 x 280	21" x 11"	—	10	200	CAP 06	32.05	26.67
	530 x 530	21" x 21"	—	10	390	CAP 11	33.74	28.16
	635 x 635	25" x 25"	—	5	280	CAP 12	78.35	65.37
760 x 760	30" x 30"	—	5	400	CAP 13	106.95	89.13	

TWICE WEATHERED COPINGS								
TYPE	METRIC (MM)	IMPERIAL	DESCRIPTION	PACK QUANTITY	PACK WEIGHT (KG)	PRODUCT CODE	SPLIT PRICE EACH (£)	PACK PRICE EACH (£)
STRAIGHT WITH WATER-DRIP GROOVES (UNLESS OTHERWISE STATED)	102	4"	610 no drip	100	570	COP 101	5.43	4.93
	125	5"	610 no drip lightweight	100	550	COP 106	5.51	4.59
	137	5 1/2"	610 no drip	64	448	COP 155	6.84	5.75
	165	6 1/2"	610	60	750	COP 111	6.55	5.95
	175	7"	610 no drip	48	432	COP 159	11.43	9.55
	222	8 3/4"	610 no drip	40	752	COP 116	13.12	11.94
	280	11"	610 no drip lightweight	40	576	COP 151	12.33	10.25
	305	12"	610	30	768	COP 121	14.98	12.43
	305	12"	915	15	563	COP 122	22.45	18.65
	355	14"	610	30	936	COP 126	17.30	15.82
	355	14"	915	15	710	COP 127	27.99	23.36
	405	16"	915	15	785	COP 131	43.54	36.27
	460	18"	915	10	602	COP 136	50.64	42.27
	510	20"	915	10	670	COP 141	63.96	53.41
	610	24"	915	10	817	COP 146	87.69	73.15
	CORNER WITH WATER-DRIP GROOVES (UNLESS OTHERWISE STATED)	102	4"	305 x 305 no drip	1	5	COP 102	—
125		5"	150 x 150 no drip lightweight	1	2	COP 107	—	5.51
137		5 1/2"	305 x 305 no drip	1	2.4	COP 156	—	6.70
165		6 1/2"	305 x 305	1	9	COP 112	—	7.13
222		8 3/4"	460 x 460 no drip	1	21	COP 117	—	14.36
280		11"	305 x 305 no drip lightweight	1	8	COP 152	—	12.33
305		12"	460 x 460	1	25	COP 123	—	22.45
355		14"	460 x 460	1	28	COP 128	—	27.98
405		16"	460 x 460	1	29	COP 132	—	43.54
460		18"	460 x 460	1	31	COP 137	—	50.62
END WITH WATER-DRIP GROOVES	165	6 1/2"	610	1	13	COP 113	—	7.13
	222	8 3/4"	610	1	18	COP 118	—	14.36
	305	12"	610	1	25	COP 124	—	22.45
	355	14"	915	1	48	COP 129	—	27.98
	405	16"	915	1	55	COP 133	—	43.54
	460	18"	915	1	59	COP 138	—	50.62
	510	20"	915	1	65	COP 143	—	63.96
	610	24"	915	1	80	COP 148	—	87.68

PIER CAP

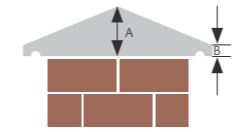

	A	B
220 x 220mm to 280 x 280mm	75	38
All other sizes	90	45
380 x 380mm	102	51

TWICE WEATHERED

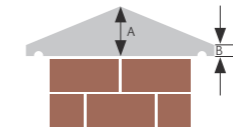

	A	B
125mm lightweight	38	25
280mm lightweight	45	32
102mm	50	38
165mm	60	50
222 - 305mm	70	50
355 - 610mm	75	50
137mm	50	32
175mm	50	32

ONCE WEATHERED

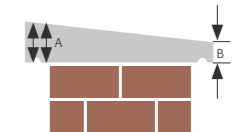

	A	B
165mm	60	50
222 - 305mm	70	50
355 - 610mm	75	50

ONCE WEATHERED COPINGS

TYPE	METRIC (MM)	IMPERIAL	DESCRIPTION	PACK QUANTITY	PACK WEIGHT (KG)	PRODUCT CODE	SPLIT PRICE EACH (£)	PACK PRICE EACH (£)
STRAIGHT WITH WATER-DRIP GROOVES (UNLESS OTHERWISE STATED)	165	6 1/2"	610	60	762	COP 201	6.55	5.95
	222	8 3/4"	610 no drip	40	732	COP 206	13.12	11.94
	305	12"	610	30	753	COP 211	14.98	12.43
	305	12"	915	15	572	COP 212	22.45	18.65
	355	14"	610	30	936	COP 216	17.30	15.82
	355	14"	915	15	714	COP 217	27.99	23.36
	405	16"	915	15	785	COP 221	43.54	36.27
	460	18"	915	10	602	COP 226	50.64	42.27
	510	20"	915	10	685	COP 231	63.96	53.41
	610	24"	915	10	815	COP 236	87.69	73.15
INTERNAL CORNER WITH WATER-DRIP GROOVES (UNLESS OTHERWISE STATED)	165	6 1/2"	305 x 305	1	9	COP 202	—	7.13
	222	8 3/4"	460 x 460 no drip	1	20	COP 207	—	14.36
	305	12"	460 x 460	1	26	COP 213	—	22.45
	355	14"	460 x 460	1	29	COP 218	—	27.99
	405	16"	460 x 460	1	30	COP 222	—	43.54
	460	18"	460 x 460	1	32	COP 227	—	50.62
	510	20"	610 x 610	1	38	COP 232	—	63.96
EXTERNAL CORNER WITH WATER-DRIP GROOVES (UNLESS OTHERWISE STATED)	165	6 1/2"	305 x 305	1	9	COP 203	—	7.13
	222	8 3/4"	460 x 460 no drip	1	20	COP 208	—	14.36
	305	12"	460 x 460	1	26	COP 214	—	22.45
	355	14"	460 x 460	1	29	COP 219	—	27.99
	405	16"	460 x 460	1	30	COP 223	—	43.54
	460	18"	460 x 460	1	32	COP 228	—	50.62
	510	20"	610 x 610	1	38	COP 233	—	63.96
	610	24"	610 x 610	1	46	COP 238	—	87.68

The top of a wall or pier is often the most exposed part of a structure and therefore very susceptible to the effects of the weather. Ibstock's range of copings and caps provides an attractive, cost-effective solution to protect these vulnerable areas.

They are available in natural and a small range of buff colours (see page 30) to harmonise with any wall construction. The products are designed in accordance with BS 5642: Part 2 and include matching end and corner units which save time and reduce the need for cutting on-site.

Many of the units incorporate water drip grooves which help prevent staining on the face of the wall and also prolong the life of the wall.

FLAT COPINGS

TYPE	METRIC (MM)	IMPERIAL	DESCRIPTION	PACK QUANTITY	PACK WEIGHT (KG)	PRODUCT CODE	SPLIT PRICE EACH (£)	PACK PRICE EACH (£)
STRAIGHT WITH WATER-DRIP GROOVES (UNLESS OTHERWISE STATED)	50MM THICK		610	30	642	COP 301	14.98	12.43
	305	12"	915	15	485	COP 302	23.07	19.17
	355	14"	915	15	564	COP 306	30.15	25.24
CORNER WITH WATER-DRIP GROOVES (UNLESS OTHERWISE STATED)	305	12"	460 x 460	1	21	COP 303	—	23.07
	355	14"	460 x 460	1	23	COP 307	—	30.15

BUFF PIER CAPS								
TYPE	METRIC (MM)	IMPERIAL	PACK QUANTITY	PACK WEIGHT (KG)	PRODUCT CODE	SPLIT PRICE EACH (£)	PACK PRICE EACH (£)	
	255 x 255	10" x 10"	24	173	PC 250 BUFF	9.55	8.66	
	300 x 300	12" x 12"	24	227	PC 300 BUFF	13.16	11.99	
	420 x 420	16 1/2" x 16 1/2"	12	299	PC 400 BUFF	19.29	16.36	
	460 x 460	18" x 18"	12	358	PC 450 BUFF	28.66	24.28	
	525 x 525	21" x 21"	12	508	PC 525 BUFF	38.01	28.88	
	600 x 600	24" x 24"	8	476	PC 600 BUFF	44.16	36.73	

BUFF COPINGS								
TYPE	METRIC (MM)	IMPERIAL	LENGTH	PACK QUANTITY	PACK WEIGHT (KG)	PRODUCT CODE	SPLIT PRICE EACH (£)	PACK PRICE EACH (£)
STRAIGHT TWICE WEATHERED WITH WATER-DRIP GROOVES (UNLESS OTHERWISE STATED)	137	5 1/2"	600 no drip	60	442	COP 137.5 BU	6.47	5.91
	275	11"	600	30	447	COP 275 BUFF	14.79	12.33
	375	15"	600	20	562	COP 375 BUFF	21.75	14.97
CORNER TWICE WEATHERED WITH WATER-DRIP GROOVES (UNLESS OTHERWISE STATED)	137	5 1/2"	165 x 165 no drip	1	2	COP 137.5 RB	—	10.62
	275	11"	330 x 330	1	10	COP 275 RBUF	—	14.79

BUFF PIER CAPS		
	A	B
255	80	35
300	80	35
420	100	50
460	100	50
525	125	65
600	120	68

BUFF TWICE WEATHERED COPING		
	A	B
137	50	30
275	50	30
375	75	50

Gain more, stock core products

CHIMNEY CAPS, WINDOW SILLS, GULLY SURROUNDS AND DOOR STEPS

Innovative precasting technology has enabled Istock to develop a range of essential building components. These are highly durable and easy to install, making them the first choice for the building professional.

CHIMNEY CAPS								
4 WAY WEATHERED WITH WATER DRIP GROOVES								
	METRIC (MM)	IMPERIAL	DESCRIPTION	PACK QUANTITY	PACK WEIGHT (KG)	PRODUCT CODE	SPLIT PRICE EACH (£)	PACK PRICE EACH (£)
	530 x 530	21" x 21"	One 11" hole	20	624	CAP 31	42.28	35.24
	635 x 635	25" x 25"	One 11" hole	10	505	CAP 32	63.19	52.59
	530 x 880	21" x 34 1/2"	Two 11" holes	10	505	CAP 33	70.28	58.64

WINDOW SILL WITH WATER DRIP GROOVES								
	METRIC (MM)	IMPERIAL	DESCRIPTION	PACK QUANTITY	PACK WEIGHT (KG)	PRODUCT CODE	SPLIT PRICE EACH (£)	PACK PRICE EACH (£)
	760	2' 6"	—	15	339	W I02	32.20	26.81
	915	3'	—	5	410	W I03	37.96	31.62
	1065	3' 6"	—	5	480	W I04	45.14	37.57
	1220	4'	—	5	549	W I05	49.71	41.39
	1370	4' 6"	—	5	650	W I06	58.30	48.44
	1525	5'	—	5	684	W I07	62.27	51.84
	1830	6'	—	5	795	W I09	77.99	64.90
	2150	7'	—	5	975	W I10	88.74	73.92

GULLY SURROUND								
	INTERNAL MEASUREMENTS		PACK QUANTITY	PACK WEIGHT (KG)	PRODUCT CODE	SPLIT PRICE EACH (£)	PACK PRICE EACH (£)	
	METRIC (MM)	IMPERIAL						
	230 x 230 x 150	9" x 9" x 6"	30	474	GUL 01	13.60	11.32	
	460 x 230 x 150	18" x 9" x 6"	25	490	GUL 02	21.08	17.68	

DOOR STEP (NOT REINFORCED)								
	METRIC (MM)	IMPERIAL	PACK QUANTITY	PACK WEIGHT (KG)	PRODUCT CODE	SPLIT PRICE EACH (£)	PACK PRICE EACH (£)	
	75MM							
	1065 x 230	3' 6" x 9"	20	780	DRS 05	41.48	34.53	
	1065 x 305	3' 6" x 12"	20	1040	DRS 06	53.66	44.64	

CLOTHES LINE POST (INCLUDES GALVANISED PEG)								
	METRIC (MM)	IMPERIAL	DIMENSIONS	PACK QUANTITY	PACK WEIGHT (KG)	PRODUCT CODE	SPLIT PRICE EACH (£)	PACK PRICE EACH (£)
	2670	8' 9"	125 > 75					

Rectangular inspection chamber

RECTANGULAR INSPECTION CHAMBER

Reinforced build: Providing durability which cuts down on breakages and site construction costs.
Tongue and groove joint detail: Allows easy placement and is suitable to receive a sealant or bedding mortar.
Can be used on depths of up to 2.7m: The vast range sizes makes it suitable for most domestic inspection chamber requirements.
 Manufactured in accordance with EN 1917:2002 (frames and covers are not covered by this EN standard).

INSPECTION CHAMBERS, FRAME AND COVER							
450MM X 600MM (AVAILABLE IN PACKS ONLY)							
	INTERNAL SIZE (MM)	DESCRIPTION	PACK QUANTITY	PACK WEIGHT (KG)	PRODUCT CODE	SPLIT PRICE EACH (£)	PACK PRICE EACH (£)
	150 depth	Chamber	14	644	DICA 150	-	21.56
225 depth	Chamber	10	680	DICA 225	-	28.75	
300 depth	Chamber	8	760	DICA 300	-	40.71	
800 x 650 x 100	Frame	10	480	FRAME A	-	59.00	
694 x 545 x 45	Cover	20	920	COVER A	-	38.29	

INSPECTION CHAMBERS, FRAME AND COVER							
750MM X 600MM (AVAILABLE IN PACKS ONLY)							
	INTERNAL SIZE (MM)	DESCRIPTION	PACK QUANTITY	PACK WEIGHT (KG)	PRODUCT CODE	SPLIT PRICE EACH (£)	PACK PRICE EACH (£)
	150 depth	Chamber	7	476	DICB 150	-	32.83
225 depth	Chamber	5	515	DICB 225	-	42.60	
300 depth	Chamber	4	484	DICB 300	-	48.41	
870 x 720 x 95	Frame	10	640	FRAME B	-	64.23	
710 x 560 x 45	Cover	20	920	COVER B	-	40.61	

INSPECTION CHAMBERS AND REDUCERS							
1000MM X 675MM (AVAILABLE IN PACKS ONLY)							
	INTERNAL SIZE (MM)	DESCRIPTION	PACK QUANTITY	PACK WEIGHT (KG)	PRODUCT CODE	SPLIT PRICE EACH (£)	PACK PRICE EACH (£)
	150 depth	Chamber	7	616	DICC 150	-	40.44
225 depth	Chamber	5	660	DICC 225	-	54.84	
300 depth	Chamber	4	632	DICC 300	-	63.43	
1000 x 675 to 450 x 600	Reducer	2	190	REDUCEC 450	-	50.04	
1000 x 675 to 750 x 600	Reducer	2	138	REDUCEC 750	-	82.96	

INSPECTION CHAMBER AND COVER SLABS							
1200MM X 750MM (AVAILABLE IN PACKS ONLY)							
	INTERNAL SIZE (MM)	DESCRIPTION	PACK QUANTITY	PACK WEIGHT (KG)	PRODUCT CODE	SPLIT PRICE EACH (£)	PACK PRICE EACH (£)
	150 depth	Chamber	7	742	DICD 150	-	58.37
90 depth	Cover Slab	2	344	COVER SLABS	-	130.86	
140 depth	Cover Slab	2	564	COVER SLABL	-	175.21	

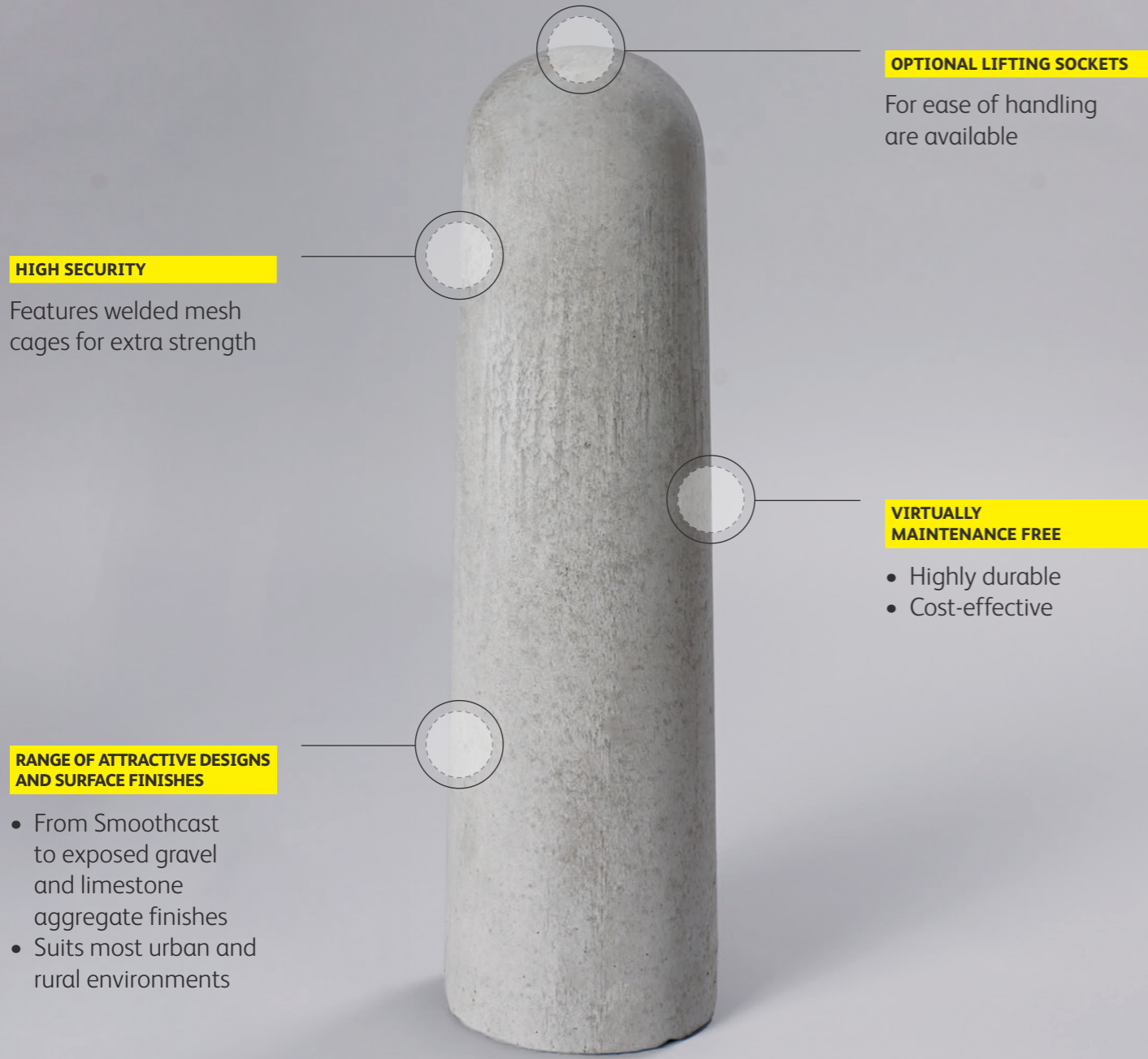

HIGH SECURITY
Features welded mesh cages for extra strength

OPTIONAL LIFTING SOCKETS
For ease of handling are available

VIRTUALLY MAINTENANCE FREE

- Highly durable
- Cost-effective

RANGE OF ATTRACTIVE DESIGNS AND SURFACE FINISHES

- From Smoothcast to exposed gravel and limestone aggregate finishes
- Suits most urban and rural environments

SMOOTHCAST™
BOLLARD

Ibstock's range of landscaping products has been developed for use in a wide range of urban and rural applications. It meets the needs of both commercial and civic organisations, being economic and aesthetic.

Landscaping products

Ibstock offers a complementary range of landscaping products to our fencing products.

Whenever a barrier to vehicle access is required, bollards are a popular solution and produced by Ibstock in a choice of finishes to meet a wide range of requirements.

Tuff Turf provides a 'green' alternative to standard concrete and tarmac car parking and access areas.

- DekBlok™ and DekPost™ make decking quick and easy

FEATURES AND BENEFITS

- Maintenance free cost-effective landscaping solution
- Wide range of bollards produced in a range of sizes and finishes
- Bollards are reinforced with a welded steel cage for extra strength
- Tuff Turf has the load-bearing strength of concrete
- The Tuff Turf design ensures excellent grass coverage without compromising the stability of the unit
- Clearly designed products saves time on-site

Gain more, stock core products

There's never a better time to increase sales, and an easy way is to stock the right range.

BUILDING PRODUCT	PRODUCT CODE	BEST SELLERS	DEVELOP YOUR RANGE
Path edgings	EDG01 (Round)	✓	✓
	EDG02 (Flat)	✓	✓
Decking	DEC001 (Pad)	✓	✓
	DP45010 (450mm post)	✓	✓
	DP60010 (600mm post)	✓	✓
Bollards	BOL137 (Nene Smooth Grey)	✓	✓
	BOL106 (Windrush Smooth Grey)	✓	✓
	BOL510 (Rutland free-standing)		✓
	BOL380 (Grafham free-standing)		✓



What do we sell?

- Smooth bollards
- Exposed aggregate bollards
- Free-standing bollards
- Path edging
- Tuff Turf
- DekBlok™ and DekPost™
- Cycle blocks
- Screed rail

LANDSCAPING PRODUCTS

Bollards

BOLLARDS

Easy to install and generally maintenance free, the Istock range of bollards is suitable for virtually every application, urban and rural, meeting all demands from the economic to the aesthetic.

BOLLARDS Smoothcast								
TYPE	METRIC (MM)	ABOVE GROUND HEIGHT (MM)	DESCRIPTION	PACK QUANTITY	PACK WEIGHT (KG)	PRODUCT CODE	SPLIT PRICE EACH (£)	PACK PRICE EACH (£)
WINDRUSH	1065 x 200>150 dia	600	Smooth Grey	7	441	BOL 106	98.30	81.86
	1065 x 200>150 dia	600	Smooth Grey with lifting socket	7	441	BOL 106 X	110.05	91.66
NENE	1370 x 225>150 dia	900	Smooth Grey	7	623	BOL 137	112.73	93.97
	1370 x 225>150 dia	900	Smooth Grey with lifting socket	7	623	BOL 137 X	124.51	103.77
ORWELL	1065 x 200>150 dia	600	Grey exposed Ouse Valley aggregate	1	64	BOLA 106	—	140.98
	1065 x 200>150 dia	600	White exposed Derbyshire aggregate	1	64	BOL 106 WE	—	154.19
CAM	1370 x 225>150 dia	900	Grey exposed Ouse Valley aggregate	1	91	BOLA 137	—	168.72
	1370 x 225>150 dia	900	White exposed Derbyshire aggregate	1	91	BOL 137 WE	—	186.86
WENSUM	1100 x 200 dia	650	Smooth Grey	1	83	BOL 1102	—	113.31
	1100 x 200 dia	650	Smooth White	1	83	BOL 1102 SW	—	128.71
	1100 x 200 dia	650	Grey exposed Ouse Valley aggregate	1	83	BOLB 1102	—	211.20
	1100 x 200 dia	650	White exposed Derbyshire aggregate	1	83	BOL 1102 WE	—	227.73
SWALE	1250 x 300 dia	800	Smooth Grey	1	216	BOL 1250	—	283.06
	1250 x 300 dia	800	Smooth White	1	216	BOL 1250 SW	—	325.40
	1250 x 300 dia	800	Grey exposed Ouse Valley aggregate	1	216	BOLB 1250	—	314.79
	1250 x 300 dia	800	White exposed Derbyshire aggregate	1	216	BOL 1250 WE	—	356.84
WELLAND	750 x 400 dia	450	Grey exposed Ouse Valley aggregate	1	160	BOLC 075	—	275.50
	750 x 400 dia	450	White exposed Derbyshire aggregate	1	160	BOL 075 WE	—	307.94
AVON	1200 x 250 dia	750	Grey exposed Ouse Valley aggregate	1	145	BOLC 120	—	247.49
	1200 x 250 dia	750	White exposed Derbyshire aggregate	1	145	BOL 120 WE	—	279.72

SMOOTH GREY



SMOOTH WHITE



OUSE VALLEY



DERBYSHIRE



FREE-STANDING BOLLARDS

Grafham and Rutland bollards are small, free-standing movable bollards suitable for both permanent and temporary uses. Ideal for driveways, traffic control and many other situations. Holed for chain attachment if required to link together.

FREE-STANDING BOLLARDS



TYPE	METRIC (MM)	DESCRIPTION	PACK QUANTITY	PACK WEIGHT (KG)	PRODUCT CODE	SPLIT PRICE EACH (£)	PACK PRICE EACH (£)
GRAFHAM	380 x 200 x 200	Smooth Grey	12	264	BOL 380	32.97	27.46
RUTLAND	510 x 300 x 300	Smooth Grey	6	418	BOL 510	64.39	53.63

GRAFHAM



RUTLAND



LIFTING SOCKETS*

Windrush and Nene bollards can be supplied with a concealed lifting socket (which includes a blanking-off button-head bolt*) as shown below. A screw-in lifting loop or lifting eye will be required which can be used many times, or in the case of the lifting eye, may be left in place for decorative chains.

The stainless steel units provide an attractive finish to the bollard.

*Installer will require an 8mm allen key (not supplied) for the blanking-off button-head bolt.

BOLLARD LIFTING SOCKETS

TYPE	DESCRIPTION	PACK QUANTITY	PACK WEIGHT (KG)	PRODUCT CODE	SPLIT PRICE EACH (£)	PACK PRICE EACH (£)
STAINLESS STEEL	Screw in lifting loop	7	—	LL 01	17.44	14.55
STAINLESS STEEL	Screw in lifting eye	7	—	LE 01	14.55	12.12

Path edging

i Our path edging features parallel sides. This makes the 'perfect' edge for use with pavers. Cutting and filling are reduced improving stability of the surface as well as saving time.

PATH EDGING



METRIC (MM)	IMPERIAL	DESCRIPTION	PACK QUANTITY	PACK WEIGHT (KG)	PRODUCT CODE	SPLIT PRICE EACH (£)	PACK PRICE EACH (£)
915 x 150 x 50	3' x 6" x 2"	Round top path edging	80	1264	EDG 01	6.21	5.17
915 x 150 x 50	3' x 6" x 2"	Flat top path edging	80	1312	EDG 02	6.21	5.17

Tuff Turf

Tuff Turf is a revolutionary grass concrete system manufactured by Ibstock.

The Tuff Turf design ensures excellent coverage without compromising the stability or strength of the unit.

A cost-effective, environmentally friendly and aesthetically pleasing green alternative to standard concrete and tarmac for car parks and access areas to fulfil commercial requirements.

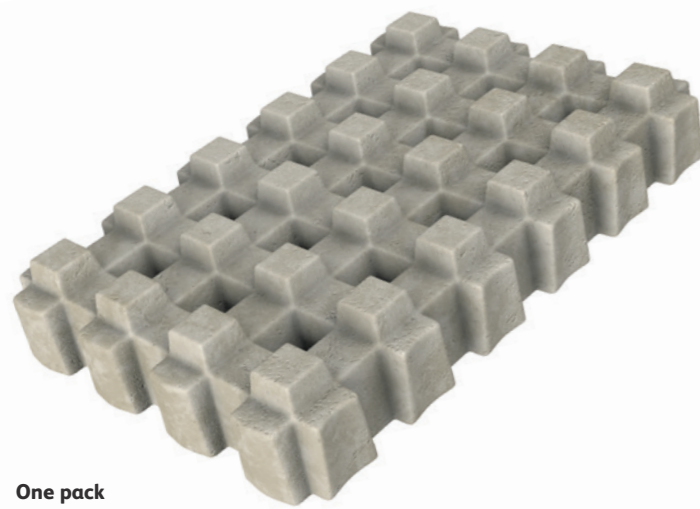

One pack covers 5.76 sq m

FEATURES AND BENEFITS

- Environmentally friendly and aesthetically pleasing
- Retains the look of a grassed area
- Load bearing strength of concrete
- Cost-effective
- Quick and simple to install
- Approximately 79% of the block's surface area is available for grass and 85% of the block is available for the distribution of load to the underlying area

TUFF TURF

AVAILABLE IN PACKS ONLY (PACK = 5.76 SQ M)

METRIC (MM)	DESCRIPTION	PACK QUANTITY	PACK WEIGHT (KG)	PRODUCT CODE	PACK PRICE EACH (£)
400 x 600 x 100	Tuff Turf	24	810	GRAS 02	257.37

Call 0333 999 2220 for a quick and competitive quote.

Direct to site delivery available.

In order to provide a competitive solution when and where you need it, Tuff Turf is no longer included in Ibstock's standard terms and discounts.

DekBlok™ and DekPost™

DEKBLOK™

One of the most difficult parts of building any deck is digging holes, mixing concrete and pouring footings for the posts. DekBlok™ from Ibstock eliminates all these steps – saving both time and money!

DEKPOST™

DekPost™ is the ideal solution for uneven or unstable ground. Their short length mean they are lightweight, easy to handle and no cutting on-site is required. They are resistant to moisture and rot.

DEKBLOK™ AND DEKPOST™

METRIC (MM)	DESCRIPTION	PACK QUANTITY	PACK WEIGHT (KG)	PRODUCT CODE	SPLIT PRICE EACH (£)	PACK PRICE EACH (£)
450 x 100 x 100	Decking support post	18	144	DP 45010	6.12	5.09
600 x 100 x 100	Decking support post	18	180	DP 60010	8.18	6.82
900 x 100 x 100	Decking support post	18	288	DP 90010	12.26	10.19
1200 x 100 x 100	Decking support post	18	378	DP 120010	16.33	13.60
300 x 300 x 100	Decking support pad	18	288	DEC 001	10.98	9.17

Cycle blocks

CYCLE BLOCKS

SLOT SIZES 32MM TO 40MM STANDARD BIKE, 42MM TO 52MM MOUNTAIN BIKE

METRIC (MM)	IMPERIAL	DESCRIPTION	PACK QUANTITY	PACK WEIGHT (KG)	PRODUCT CODE	SPLIT PRICE EACH (£)	PACK PRICE EACH (£)
610 x 325 x 103	24" x 12 3/4"	Left hand standard cycle slot	30	1065	CYC 01	29.35	24.45
610 x 325 x 103	24" x 12 3/4"	Right hand standard cycle slot	30	1065	CYC 02	29.35	24.45
600 x 300 x 103	—	Standard and mountain bike cycle slot	30	984	CYC 03	31.32	26.12
—	—	Locking ring for cycle block	30	—	CYC 11	23.10	19.25

Screed rails

SCREED RAILS

The Ibstock screed rail system is ideal for the construction of industrial floors, pathways, hard standing areas, pads and bases.

Ibstock screed rails are manufactured with Strongcast Concrete. They contain steel reinforcement along the length of the rail, positioned in three settings. The rails are manufactured in an L shaped profile, three metres in length. They are available in two heights, 100mm and 150mm. The weight of a 100mm high three metre length is approximately 30kg and the 150mm high is approximately 45kg.

The most economic option of laying a concrete floor is the long strip construction method, utilising bays of as great a width as possible (taking into account the size of the screeding machine to be used and/or the bay specification width). This method of construction is ideally suited to the Ibstock screed rail system.

SCREED RAILS

METRIC (MM)	DESCRIPTION	PACK QUANTITY	PACK WEIGHT (KG)	PRODUCT CODE	SPLIT PRICE EACH (£)	PACK PRICE EACH (£)
50	Mesh support castles (Bags of 100)	1	21	SCR 001	—	77.79
3000 x 100	Screed rail	42	1260	SCR 100	29.53	24.57
3000 x 150	Screed rail	28	1268	SCR 150	33.84	28.26

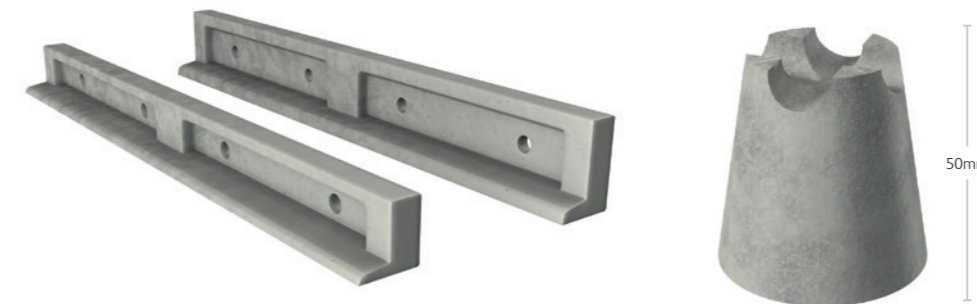

FEATURES AND BENEFITS

- Totally eliminates the need for steel or timber formers and the associated costs of hire charges, cleaning, replacement and repair
- Speedier adjacent bay construction without the need to strike, thus allowing bays to be cast wet next to wet if required, giving a cost and time saving
- Elimination of spalling at the joint, which can occur when striking steel forms
- Significant cost savings. They are cheaper, easier to use and quicker to install than adjustable steel forms
- As there is no need for steel pins, there is no risk of damage to the membrane
- Use of screed rail allows the continuous fixing of steel reinforcement and productivity improvement are achieved as 'hit and miss' bays are eliminated
- The standard three metre lengths are easy to handle on-site
- Precision manufacture ensures a tolerance of just +/- 5mm over a 3m length. This makes the levelling process very easy, giving an extremely flat surface
- In external use, it is far easier to achieve excellent results where there are complex drainage requirements

VERY STRONG AND DURABLE

Made from dense concrete



INDIVIDUALLY MARKED

Easy to identify

ENGINEERED TO PERFORM

For consistent strength

VARIOUS SIZES

Various sizes available including corners. Ideal for most applications

COMPLEMENTARY RANGE OF LINTELS

Ideal for Istock and all other lintel types



STRUCTURAL PRODUCTS

STRONGCAST™
ORIGINAL PADSTONE

Ibstock's range of precision made concrete structural products has been specially developed to meet the needs of today's building and construction-sites. They offer great value and high performance combined with unmatched technical support and delivery. They are relied on by the tradesperson for their quality and easy of use.

Gain more, stock core products

There's never a better time to increase sales, and an easy way is to stock the right range.

BUILDING PRODUCT	PRODUCT CODE	BEST SELLERS	DEVELOP YOUR RANGE
Padstones	PAD 12	✓	✓
	PAD 07	✓	✓
	PAD 03		✓
	PAD 02		✓
Prestressed premium lintels	P100060	✓	✓
	P100090	✓	✓
	P100105	✓	✓
	P100120	✓	✓
	P100150	✓	✓
	P100180	✓	✓
	P100210	✓	✓
	P100240		✓
	P100045		✓
	P100135		✓
	P100270		✓
	P100300		✓
	P150060		✓
	P150090		✓
P150120		✓	
P220120		✓	
Premium strength	R15090	✓	✓
	R15120	✓	✓
	R15150	✓	✓
	R15180	✓	✓
	R15210	✓	✓
	R15240	✓	✓
	R15270	✓	✓
	R15300	✓	✓
	R15060		✓
	R15135		✓
	R22120		✓
	R22150		✓
	R22180		✓
	R22210		✓
	R22240		✓

Structural benefits

Ibstock has a long history making structural concrete products. These include an extensive range of prestressed and traditional precast lintels. The complementary range of 'Pad' branded padstones optimise the performance of Ibstock's lintel range.

The pioneering Ibstock floor beam system has been developed to accelerate the build process through the quick and easy creation of safe working floors whilst reducing the need for extensive ground works.

An innovative range of retaining and walling systems provides highly versatile solutions for building and infrastructure projects.

FEATURES AND BENEFITS

- Choice of both prestressed and precast lintels
- Textured finish to lintels provides an ideal key for rendering and plastering
- Ibstock's prestressed technology offers superior strength over equivalent 'traditional' precast section sizes
- The use of lightweight aggregate ensures superior fire resistance, while the reduced weight makes handling easier
- Unmatched design and technical support makes the selection and use of Ibstock's structural products simple
- Range features Ibstock's Strongcast concrete technology

What do we sell?

- Prestressed premium lintels
- High strength
- Prestressed lintels
- Precast lintels
- Padstones
- Fireplace lintels
- Suspended beam and block floor
- Stepoc shuttering system
- Keystone retaining walling system
- Slope-Loc retaining
- High Fire and Extreme Fire Rated Lintels

Lintels

PRESTRESSED PREMIUM AND PRECAST LINTELS AND PADSTONES

For strength and value.

The prestressed premium range is a high-strength option for when there are exceptional load requirements.

Featuring the Ibstock superior concrete technology – both precast and prestressed lintels are manufactured with a textured finish.

A range of complementary padstones is available to provide the perfect support for your Ibstock lintels.

With the exception of Extreme Fire Rated lintels, all lintels can be cut to the design length.

Manufactured in accordance with EN 845-2:2013.

Loading guide: The loads on the lintels are assessed in accordance with the method described in Eurocode 2 EN 1992-1-1:-2004, EN 1990, EN 1991-1-1.

P100 100 X 65MM (4" X 2.5")

METRIC (MM)	PACK QUANTITY	PACK WEIGHT (KG)	PRODUCT CODE	SPLIT PRICE EACH (£)	PACK PRICE EACH (£)
450	48	308	P 100045	4.68	4.45
600	48	411	P 100060	6.22	5.92
750	24	257	P 100075	7.76	7.39
900	24	308	P 100090	9.30	8.85
1050	24	360	P 100105	10.79	10.27
1200	24	411	P 100120	12.34	11.74
1350	16	308	P 100135	13.88	13.20
1500	16	342	P 100150	15.42	14.67
1650	16	377	P 100165	16.96	16.14
1800	8	205	P 100180	18.50	17.60
2100	8	240	P 100210	21.59	20.54
2400	8	274	P 100240	24.67	23.47
2700	1	39	P 100270	—	26.41
3000	1	43	P 100300	—	29.34
3300	1	47	P 100330	—	32.27
3600	1	51	P 100360	—	35.21

* Please note the imperial measurements include some rounding up to the nearest 1/2 inch.

P150 140 X 65MM (5.5" X 2.5")

METRIC (MM)	PACK QUANTITY	PACK WEIGHT (KG)	PRODUCT CODE	SPLIT PRICE EACH (£)	PACK PRICE EACH (£)
450	16	140	P 150045	6.89	6.55
600	16	186	P 150060	9.18	8.72
750	16	233	P 150075	11.46	10.89
900	16	279	P 150090	13.74	13.06
1050	16	326	P 150105	15.97	15.17
1200	16	372	P 150120	18.25	17.34
1350	16	419	P 150135	20.53	19.51
1500	16	465	P 150150	22.82	21.68
1650	16	512	P 150165	25.10	23.84
1800	8	279	P 150180	27.38	26.01
2100	8	326	P 150210	31.94	30.35
2400	8	372	P 150240	36.50	34.68
2700	1	52	P 150270	—	39.02
3000	1	58	P 150300	—	43.35
3300	1	64	P 150330	—	47.69
3600	1	70	P 150360	—	52.02

* Please note the imperial measurements include some rounding up to the nearest 1/2 inch.

P220 215 X 65MM (8.5" X 2.5")

METRIC (MM)	PACK QUANTITY	PACK WEIGHT (KG)	PRODUCT CODE	SPLIT PRICE EACH (£)	PACK PRICE EACH (£)
450	10	145	P 220045	9.76	9.43
600	10	193	P 220060	12.99	12.55
750	10	242	P 220075	16.23	15.68
900	10	290	P 220090	19.46	18.81
1050	10	338	P 220105	22.65	21.88
1200	10	386	P 220120	25.88	25.01
1350	10	435	P 220135	29.12	28.13
1500	10	483	P 220150	32.36	31.26
1650	10	531	P 220165	35.59	34.39
1800	10	580	P 220180	38.83	37.51
2100	10	676	P 220210	45.30	43.76
2400	10	773	P 220240	51.77	50.02
2700	1	87	P 220270	—	56.27
3000	1	97	P 220300	—	62.52
3300	1	106	P 220330	—	68.77
3600	1	116	P 220360	—	75.02

* Please note the imperial measurements include some rounding up to the nearest 1/2 inch.

P255 255 X 65MM (10" X 2.5")

METRIC (MM)	PACK QUANTITY	PACK WEIGHT (KG)	PRODUCT CODE	SPLIT PRICE EACH (£)	PACK PRICE EACH (£)
450	8	128	P 255045	11.35	10.82
600	8	171	P 255060	15.11	14.41
750	8	214	P 255075	18.88	18.01
900	16	513	P 255090	22.64	21.60
1050	16	598	P 255105	26.36	25.14
1200	16	684	P 255120	30.12	28.73
1350	16	769	P 255135	33.89	32.32
1500	16	855	P 255150	37.65	35.91
1650	16	940	P 255165	41.42	39.50
1800	16	1026	P 255180	45.18	43.09
2100	16	1197	P 255210	52.71	50.27
2400	16	1367	P 255240	60.24	57.46
2700	1	96	P 255270	—	64.64
3000	1	107	P 255300	—	71.82
3300	1	118	P 255330	—	79.00
3600	1	128	P 255360	—	86.18

* Please note the imperial measurements include some rounding up to the nearest 1/2 inch.

S10 100 X 100MM (4" X 4")

METRIC (MM)	PACK QUANTITY	PACK WEIGHT (KG)	PRODUCT CODE	SPLIT PRICE EACH (£)	PACK PRICE EACH (£)
450	20	206	S 10045	6.83	6.49
600	20	275	S 10060	9.09	8.63
750	20	344	S 10075	11.35	10.78
900	20	412	S 10090	13.61	12.92
1050	20	481	S 10105	15.82	15.02
1200	20	550	S 10120	18.08	17.16
1350	20	618	S 10135	20.34	19.31
1500	20	687	S 10150	22.61	21.45
1650	20	756	S 10165	24.87	23.60
1800	20	825	S 10180	27.13	25.74
2100	20	962	S 10210	31.65	30.03
2400	20	1100	S 10240	36.17	34.32
2700	1	62	S 10270	—	38.61
3000	1	69	S 10300	—	42.90
3300	1	76	S 10330	—	47.19
3600	1	82	S 10360	—	51.48

* Please note the imperial measurements include some rounding up to the nearest 1/2 inch.

S15 140 X 150MM (5.5" X 6")

METRIC (MM)	PACK QUANTITY	PACK WEIGHT (KG)	PRODUCT CODE	SPLIT PRICE EACH (£)	PACK PRICE EACH (£)
450	14	266	S 15045	20.88	19.88
600	14	354	S 15060	27.82	26.49
750	14	443	S 15075	34.77	33.10
900	14	532	S 15090	41.71	39.71
1050	14	620	S 15105	48.60	46.27
1200	14	709	S 15120	55.55	52.88
1350	14	797	S 15135	62.49	59.49
1500	14	886	S 15150	69.44	66.11
1650	14	974	S 15165	76.38	72.72
1800	14	1063	S 15180	83.32	79.33
2100	14	1240	S 15210	97.21	92.55
2400	14	1417	S 15240	111.10	105.77
2700	1	114	S 15270	—	118.99
3000	1	127	S 15300	—	132.21
3300	1	139	S 15330	—	145.43
3600	1	152	S 15360	—	158.65

* Please note the imperial measurements include some rounding up to the nearest 1/2 inch.

R15/R15A 140 X 100MM OR 100 X 140MM (5.5" X 4" / 4" X 5.5")

METRIC (MM)	PACK QUANTITY	PACK WEIGHT (KG)	PRODUCT CODE	SPLIT PRICE EACH (£)	PACK PRICE EACH (£)
450	10	139	R 15045	10.75	10.25
600	10	185	R 15060	14.32	13.65
750	10	232	R 15075	17.89	17.05
900	10	278	R 15090	21.45	20.44
1050	10	325	R 15105	24.97	23.79
1200	10	371	R 15120	28.54	27.19
1350	10	417	R 15135	32.10	30.59
1500	10	464	R 15150	35.67	33.99
1650	10	510	R 15165	39.24	37.39
1800	5	278	R 15180	42.80	40.79
2100	5	325	R 15210	49.94	47.59
2400	5	371	R 15240	57.07	54.38
2700	1	83	R 15270	—	61.18
3000	1	93	R 15300	—	67.98
3300	1	102	R 15330	—	74.78
3600	1	111	R 15360	—	81.58

* Please note the imperial measurements include some rounding up to the nearest 1/2 inch.

R21/R21A 215 X 140MM OR 140 X 215MM (8.5" X 5.5" / 5.5" X 8.5")

METRIC (MM)	PACK QUANTITY	PACK WEIGHT (KG)	PRODUCT CODE	SPLIT PRICE EACH (£)	PACK PRICE EACH (£)
450	15	431	R 21045	25.00	23.84
600	15	574	R 21060	33.31	31.77
750	15	718	R 21075	41.63	39.70
900	15	862	R 21090	49.95	47.63
1050	15	1005	R 21105	58.21	55.51
1200	15	1149	R 21120	66.53	63.44
1350	10	862	R 21135	74.84	71.37
1500	10	957	R 21150	83.16	79.31
1650	10	1053	R 21165	91.48	87.24
1800	10	1149	R 21180	99.79	95.17
2100	10	1340	R 21210	116.42	111.03
2400	10	1532	R 21240	133.06	126.89
2700	1	172	R 21270	—	142.75
3000	1	191	R 21300	—	158.61
3300	1	211	R 21330	—	174.47
3600	1	230	R 21360	—	190.33

* Please note the imperial measurements include some rounding up to the nearest 1/2 inch.

R22/R22A 215 X 100MM OR 100 X 215MM (8.5" X 4" / 4" X 8.5")

METRIC (MM)	PACK QUANTITY	PACK WEIGHT (KG)	PRODUCT CODE	SPLIT PRICE EACH (£)	PACK PRICE EACH (£)
450	10	205	R 22045	20.88	19.88
600	10	274	R 22060	27.82	26.49
750	10	342	R 22075	34.77	33.10
900	10	410	R 22090	41.71	39.71
1050	10	479	R 22105	48.60	46.27
1200	10	547	R 22120	55.55	52.88
1350	10	616	R 22135	62.49	59.49
1500	10	684	R 22150	69.44	66.11
1650	10	752	R 22165	76.38	72.72
1800	10	821	R 22180	83.32	79.33
2100	10	957	R 22210	97.21	92.55
2400	10	1094	R 22240	111.10	105.77
2700	1	123	R 22270	—	118.99
3000	1	137	R 22300	—	132.21
3300	1	150	R 22330	—	145.43
3600	1	164	R 22360	—	158.65

* Please note the imperial measurements include some rounding up to the nearest 1/2 inch.

R23 215 X 215MM (8.5" X 8.5")

METRIC (MM)	PACK QUANTITY	PACK WEIGHT (KG)	PRODUCT CODE	SPLIT PRICE EACH (£)	PACK PRICE EACH (£)
450	10	470	R 23045	32.32	31.07
600	10	630	R 23060	43.07	41.41
750	10	780	R 23075	53.83	51.76
900	10	940	R 23090	64.58	62.10
1050	10	1100	R 23105	75.29	72.39
1200	10	1260	R 23120	86.04	82.73
1350	10	1420	R 23135	96.80	93.07
1500	10	1570	R 23150	107.55	103.41
1650	10	173	R 23165	—	113.75
1800	10	189	R 23180	—	124.09
2100	10	220	R 23210	—	144.77
2400	10	252	R 23240	—	164.77
2700	1	283	R 23270	—	184.66
3000	1	315	R 23300	—	194.55
3300	1	346	R 23330	—	204.44
3600	1	378	R 23360	—	214.33

* Please note the imperial measurements include some rounding up to the nearest 1/2 inch.

TEXTURED RANGE OF LINTELS LOADSPAN TABLE

High Fire Rated & Extreme Fire Rated Lintels

LIFE-SAVING MINUTES BUILT IN

We are pleased to introduce our new, highly comprehensive and full range of high-quality, fire-rated lintels, all of which have been tested in compliance with industry specifications. Our Extreme Fire Rated lintels are part of this range and offer you a choice of fire rated lintels that have been proven by our stringent tests to maintain a **300-minute load bearing capability**, when subject to fire conditions.

Buildings are designed to withstand actions from numerous anticipated hazards to ensure life and structural safety. Fire represents an extreme hazard that can occur and it is crucial that firefighting and rescue operations have as much time as possible to save lives. Here at Ibstock, we are recognised as an experienced and trusted supplier of the essential building components you need, who can be trusted to ensure structural stability during fire exposure and to contain fire spread.

HF R15
140 X 100MM* (5.5" X 4")

METRIC (MM)	PACK QUANTITY	SINGLE WEIGHT (KG)	PRODUCT CODE	PACK PRICE EACH (£)
450	1	13.91	HFR 15045	47.79
600	1	18.54	HFR 15060	63.70
750	1	23.18	HFR 15075	79.61
900	1	27.81	HFR 15090	95.52
1050	1	32.45	HFR 15105	111.38
1200	1	37.08	HFR 15120	127.30
1350	1	41.72	HFR 15135	143.21
1500	1	46.35	HFR 15150	159.12
1650	1	50.99	HFR 15165	175.03
1800	1	55.62	HFR 15180	190.94
2100	1	64.89	HFR 15210	222.77
2400	1	74.16	HFR 15240	254.59
2700	1	83.43	HFR 15270	286.42
3000	1	92.70	HFR 15300	318.24
3300	1	101.97	HFR 15330	350.06
3600	1	111.24	HFR 15360	381.89
4200	1	139.05	HFR 15420	445.54

HF S15
140 X 150MM (5.5" X 6")

METRIC (MM)	PACK QUANTITY	SINGLE WEIGHT (KG)	PRODUCT CODE	PACK PRICE EACH (£)
450	1	18.99	HFS 15045	66.87
600	1	25.32	HFS 15060	89.14
750	1	31.65	HFS 15075	111.42
900	1	37.98	HFS 15090	133.69
1050	1	44.31	HFS 15105	155.91
1200	1	50.64	HFS 15120	178.19
1350	1	56.97	HFS 15135	200.46
1500	1	63.30	HFS 15150	222.74
1650	1	69.63	HFS 15165	245.01
1800	1	75.96	HFS 15180	267.28
2100	1	88.62	HFS 15210	311.83
2400	1	101.28	HFS 15240	356.38
2700	1	113.94	HFS 15270	400.92
3000	1	126.60	HFS 15300	445.47
3300	1	139.26	HFS 15330	490.02
3600	1	151.92	HFS 15360	534.56
4200	1	200.00	HFS 15420	623.66

HF R21
215 X 140MM (8.5" X 5.5")

METRIC (MM)	PACK QUANTITY	SINGLE WEIGHT (KG)	PRODUCT CODE	PACK PRICE EACH (£)
450	1	28.71	HFR 21045	106.36
600	1	38.28	HFR 21060	141.80
750	1	47.85	HFR 21075	177.24
900	1	57.42	HFR 21090	212.68
1050	1	66.99	HFR 21105	248.06
1200	1	76.56	HFR 21120	283.50
1350	1	86.13	HFR 21135	318.94
1500	1	95.70	HFR 21150	354.38
1650	1	105.27	HFR 21165	389.81
1800	1	114.84	HFR 21180	425.25
2100	1	133.98	HFR 21210	496.13
2400	1	153.12	HFR 21240	567.00
2700	1	172.26	HFR 21270	637.88
3000	1	191.40	HFR 21300	708.75
3300	1	210.54	HFR 21330	779.63
3600	1	229.68	HFR 21360	850.50
4200	1	287.10	HFR 21420	992.25

HF R21A
140 X 215MM (5.5" X 8.5")

METRIC (MM)	PACK QUANTITY	SINGLE WEIGHT (KG)	PRODUCT CODE	PACK PRICE EACH (£)
450	1	28.71	HFR 21A045	102.71
600	1	38.28	HFR 21A060	136.93
750	1	47.85	HFR 21A075	171.15
900	1	57.42	HFR 21A090	205.37
1050	1	66.99	HFR 21A105	239.54
1200	1	76.56	HFR 21A120	273.76
1350	1	86.13	HFR 21A135	307.98
1500	1	95.70	HFR 21A150	342.20
1650	1	105.27	HFR 21A165	376.41
1800	1	114.84	HFR 21A180	410.63
2100	1	133.98	HFR 21A210	479.07
2400	1	153.12	HFR 21A240	547.51
2700	1	172.26	HFR 21A270	615.95
3000	1	191.40	HFR 21A300	684.39
3300	1	210.54	HFR 21A330	752.83
3600	1	229.68	HFR 21A360	821.27
4200	1	287.10	HFR 21A420	958.15

HF R23
215 X 215MM (8.5" X 8.5")

METRIC (MM)	PACK QUANTITY	SINGLE WEIGHT (KG)	PRODUCT CODE	PACK PRICE EACH (£)
450	1	47.25	HFR23045	157.64
600	1	63.00	HFR23060	210.16
750	1	78.75	HFR23075	262.69
900	1	94.50	HFR23090	315.22
1050	1	110.25	HFR23105	367.70
1200	1	126.00	HFR23120	420.23
1350	1	141.75	HFR23135	472.76
1500	1	157.50	HFR23150	525.29
1650	1	173.25	HFR23165	577.81
1800	1	189.00	HFR23180	630.34
2100	1	220.50	HFR23210	735.40
2400	1	252.00	HFR23240	840.46
2700	1	283.50	HFR23270	945.51
3000	1	315.00	HFR23300	1050.57
3300	1	346.50	HFR23330	1155.63
3600	1	378.00	HFR23360	1260.68
4200	1	440.00	HFR23420	1470.80

XF R23
215 X 215MM* (8.5" X 8.5")

METRIC (MM)	PACK QUANTITY	SINGLE WEIGHT (KG)	PRODUCT CODE	PACK PRICE EACH (£)
450	1	33.40	XFR 23045	231.30
600	1	44.60	XFR 23060	308.38
750	1	55.70	XFR 23075	385.46
900	1	66.90	XFR 23090	462.54
1050	1	78.00	XFR 23105	539.57
1200	1	89.20	XFR 23120	616.66
1350	1	100.30	XFR 23135	693.74
1500	1	111.50	XFR 23150	770.82
1650	1	122.60	XFR 23165	847.90
1800	1	133.70	XFR 23180	924.98
2100	1	156.00	XFR 23210	1079.15
2400	1	178.30	XFR 23240	1233.31
2700	1	200.60	XFR 23270	1387.48
3000	1	222.90	XFR 23300	1541.64
3300	1	250.00	XFR 23330	1695.80
3600	1	281.00	XFR 23360	1849.97

* Width x height. Please note the imperial measurements include some rounding up to the nearest 1/2 inch.

XF R24
105 X 140MM* (4" X 5.5")

METRIC (MM)	PACK QUANTITY	SINGLE WEIGHT (KG)	PRODUCT CODE	PACK PRICE EACH (£)
450	1	10.50	XFR 24045	72.59
600	1	14.00	XFR 24060	96.76
750	1	17.60	XFR 24075	120.94
900	1	21.10	XFR 24090	145.12
1050	1	24.60	XFR 24105	169.25
1200	1	28.10	XFR 24120	193.43
1350	1	31.60	XFR 24135	217.61
1500	1	35.10	XFR 24150	241.79
1650	1	38.60	XFR 24165	265.96
1800	1	42.10	XFR 24180	290.14
2100	1	49.10	XFR 24210	338.50
2400	1	56.20	XFR 24240	386.86
2700	1	63.20	XFR 24270	435.21
3000	1	70.20	XFR 24300	483.57
3300	1	79.00	XFR 24330	531.93
3600	1	86.70	XFR 24360	580.28

XF R25
105 X 215MM* (4" X 8.5")

METRIC (MM)	PACK QUANTITY	SINGLE WEIGHT (KG)	PRODUCT CODE	PACK PRICE EACH (£)
450	1	17.00	XFR 25045	107.61
600	1	22.70	XFR 25060	143.47
750	1	28.40	XFR 25075	179.32
900	1	34.00	XFR 25090	215.18
1050	1	39.70	XFR 25105	250.98
1200	1	45.40	XFR 25120	286.84
1350	1	51.00	XFR 25135	322.69
1500	1	56.70	XFR 25150	358.55
1650	1	62.40	XFR 25165	394.40
1800	1	68.00	XFR 25180	430.25
2100	1	79.40	XFR 25210	501.96
2400	1	90.70	XFR 25240	573.67
2700	1	102.10	XFR 25270	645.38
3000	1	113.40	XFR 25300	717.09
3300	1	122.10	XFR 25330	788.80
3600	1	133.30	XFR 25360	860.51

XF R26
140 X 215MM* (5.5" X 8.5")

METRIC (MM)	PACK QUANTITY	SINGLE WEIGHT (KG)	PRODUCT CODE	PACK PRICE EACH (£)
450	1	23.00	XFR 26045	150.63
600	1	30.70	XFR 26060	200.82
750	1	38.40	XFR 26075	251.02
900	1	46.10	XFR 26090	301.21
1050	1	53.80	XFR 26105	351.35
1200	1	61.40	XFR 26120	401.54
1350	1	69.10	XFR 26135	451.74
1500	1	76.80	XFR 26150	501.93
1650	1	84.50	XFR 26165	552.12
1800	1	92.20	XFR 26180	602.32
2100	1	107.50	XFR 26210	702.70
2400	1	122.90	XFR 26240	803.09
2700	1	138.20	XFR 26270	903.47
3000	1	153.60	XFR 26300	1003.86
3300	1	178.00	XFR 26330	1104.25
3600	1	194.00	XFR 26360	1204.63

XF R27
140 X 140MM* (5.5" X 5.5")

METRIC (MM)	PACK QUANTITY	SINGLE WEIGHT (KG)	PRODUCT CODE	PACK PRICE EACH (£)
450	1	15.50	XFR27045	104.95
600	1	20.70	XFR27060	139.92
750	1	25.90	XFR27075	174.88
900	1	31.10	XFR27090	209.85
1050	1	36.20	XFR27105	244.77
1200	1	41.40	XFR27120	279.73
1350	1	46.60	XFR27135	314.70
1500	1	51.80	XFR27150	349.67
1650	1	56.90	XFR27165	384.63
1800	1	62.10	XFR27180	419.60
2100	1	72.50	XFR27210	489.53
2400	1	82.80	XFR27240	559.46
2700	1	93.20	XFR27270	629.40
3000	1	103.50	XFR27300	699.33
3300	1	124.40	XFR27330	769.26
3600	1	135.50	XFR27360	839.20

HIGH FIRE RATED LINTELS LOADSPAN TABLE (90-120 minutes fire rating)

SIZE TO ORDER	LINTEL REFERENCE	HF R15	HF S15	HF R21	HF R21A	HF R23
		SECTION PROFILE	140 x 100*	140 x 150	215 x 140	140 x 215
MAXIMUM SERVICE LOAD IN kN/m (IN ADDITION TO SELF WEIGHT)						
600	300	80.70	113.39	175.77	238.16	237.78
750	450	58.60	82.33	127.64	173.01	172.63
900	600	39.87	64.58	100.14	135.79	135.41
1050	750	26.93	53.10	82.34	111.70	111.32
1200	900	19.37	45.06	60.61	94.84	94.46
1350	1050	14.56	39.12	45.66	82.38	82.00
1500	1200	11.33	34.55	35.57	72.79	72.41
1650	1350	9.04	28.00	28.46	65.19	64.81
1800	1500	7.36	22.90	23.24	57.28	56.90
2100	1800	5.13	16.10	16.28	40.41	40.03
2400	2100	3.74	11.88	11.96	29.96	29.58
2700	2400	2.82	9.09	9.10	23.04	22.66
3000	2700	2.18	7.15	7.11	18.22	17.85
3300	3000	1.72	5.74	5.67	14.74	14.36
3600	3300	1.37	4.69	4.60	12.13	11.75
4200	3900	0.90	3.25	3.12	8.57	8.19

* Width x height
Safe working loads indicated are based on the clear span plus 150mm of bearing each end.
Our lintels can be cut to length as required.

EXTREME FIRE RATED LINTELS LOADSPAN TABLE (up to 300 minutes fire rating)

SIZE TO ORDER	LINTEL REFERENCE	XF R23	XF R24	XF R25	XF R26	XF R27
		SECTION PROFILE	215 x 215*	105 x 140	105 x 215	140 x 215
MAXIMUM SERVICE LOAD IN kN/m (IN ADD						

GUIDANCE NOTES

No assistance from composite brickwork is assumed or included in these figures. Bearings: minimum bearing length to be 150mm each. Where required provide suitable Padstones. Ensure, however that all bearings are sound.

Where information on self weights of individual units is given this is intended for guidance purposes only. They are subject to change depending upon changes to the raw materials used so it is important to check the actual weights before use if this is a critical factor.

Most clear spans shown above are in increments of 150mm and the safe working loads indicated are based on the clear span plus 150mm of bearing each end. Our lintels are supplied in a standard range of lengths and can be cut to length as required.

Deflection information is available for our full range of lintels, please see Ibstock DoP or contact our technical department.

PLEASE NOTE! Lengths indicated * are not available in all section sizes.

The safe working loads indicated in the grey band on the longer spans are not great relative to the span, these lintels should be used with caution.

Universal profile means that they can be ideal for use either 'top or bottom' up depending upon surface finish required.



Hi-strength lintels – textured finish

i These lintels are not universal and must be used in the correct orientation.

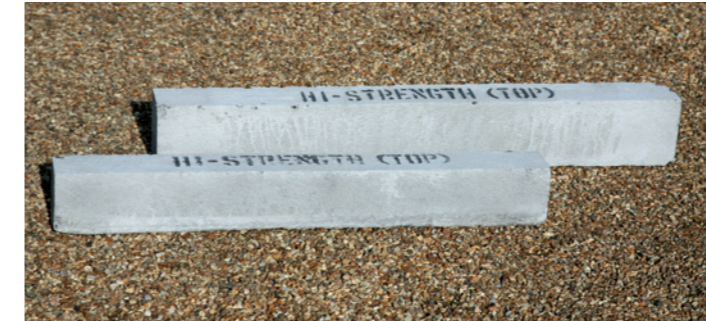

HSR15 100 X 140MM (4" X 5.5")					
METRIC (MM)	PACK QUANTITY	PACK WEIGHT (KG)	PRODUCT CODE	SPLIT PRICE EACH (£)	PACK PRICE EACH (£)
900	10	278	HSR 15090	42.45	40.39
1050	10	325	HSR 15105	49.47	47.06
1200	10	371	HSR 15120	56.53	53.78
1350	10	417	HSR 15135	63.60	60.51
1500	10	464	HSR 15150	70.67	67.23
1650	10	510	HSR 15165	77.73	73.95
1800	5	278	HSR 15180	84.80	80.68
2100	5	325	HSR 15210	98.93	94.12
2400	5	371	HSR 15240	113.06	107.57
2700	1	83	HSR 15270	—	121.01
3000	1	93	HSR 15300	—	134.46
3300	1	102	HSR 15330	—	147.91
3600	1	111	HSR 15360	—	161.35

HSR21 140 X 215MM (5.5" X 8.5")					
METRIC (MM)	PACK QUANTITY	PACK WEIGHT (KG)	PRODUCT CODE	SPLIT PRICE EACH (£)	PACK PRICE EACH (£)
900	15	862	HSR 21090	92.93	88.51
1050	15	1005	HSR 21105	108.36	103.20
1200	15	1149	HSR 21120	123.84	117.95
1350	10	862	HSR 21135	139.32	132.69
1500	10	957	HSR 21150	154.80	147.44
1650	10	1053	HSR 21165	170.28	162.18
1800	10	1149	HSR 21180	185.76	176.92
2100	10	1340	HSR 21210	216.72	206.41
2400	10	1532	HSR 21240	247.68	235.90
2700	1	172	HSR 21270	—	265.38
3000	1	191	HSR 21300	—	294.87
3300	1	211	HSR 21330	—	324.36
3600	1	230	HSR 21360	—	353.84

HSS10 100 X 110MM (4" X 4.3")					
METRIC (MM)	PACK QUANTITY	PACK WEIGHT (KG)	PRODUCT CODE	SPLIT PRICE EACH (£)	PACK PRICE EACH (£)
900	20	412	HSS 10090	29.96	28.51
1050	20	481	HSS 10105	34.89	33.20
1200	20	550	HSS 10120	39.88	37.94
1350	20	618	HSS 10135	44.86	42.69
1500	20	687	HSS 10150	49.85	47.43
1650	20	756	HSS 10165	54.83	52.17
1800	20	825	HSS 10180	59.81	56.92
2100	20	962	HSS 10210	69.78	66.40
2400	20	1100	HSS 10240	79.75	75.89
2700	1	62	HSS 10270	—	85.37
3000	1	69	HSS 10300	—	94.86
3300	1	76	HSS 10330	—	104.35
3600	1	82	HSS 10360	—	113.83

HSS15 140 X 150MM (5.5" X 6")					
METRIC (MM)	PACK QUANTITY	PACK WEIGHT (KG)	PRODUCT CODE	SPLIT PRICE EACH (£)	PACK PRICE EACH (£)
900	14	532	HSS 15090	63.06	60.09
1050	14	620	HSS 15105	73.51	70.05
1200	14	709	HSS 15120	84.01	80.05
1350	14	797	HSS 15135	94.51	90.06
1500	14	886	HSS 15150	105.02	100.07
1650	14	974	HSS 15165	115.52	110.07
1800	14	1063	HSS 15180	126.02	120.08
2100	14	1240	HSS 15210	147.02	140.09
2400	14	1417	HSS 15240	168.02	160.10
2700	1	114	HSS 15270	—	180.12
3000	1	127	HSS 15300	—	200.13
3300	1	139	HSS 15330	—	220.14
3600	1	152	HSS 15360	—	240.16

HSR22 100 X 215MM (4" X 8.5")					
METRIC (MM)	PACK QUANTITY	PACK WEIGHT (KG)	PRODUCT CODE	SPLIT PRICE EACH (£)	PACK PRICE EACH (£)
900	10	410	HSR 22090	65.59	62.44
1050	10	479	HSR 22105	76.46	72.79
1200	10	547	HSR 22120	87.38	83.18
1350	10	616	HSR 22135	98.31	93.58
1500	10	684	HSR 22150	109.23	103.98
1650	10	752	HSR 22165	120.15	114.38
1800	10	821	HSR 22180	131.08	124.78
2100	10	957	HSR 22210	152.92	145.57
2400	10	1094	HSR 22240	174.77	166.37
2700	1	123	HSR 22270	—	187.16
3000	1	137	HSR 22300	—	207.96
3300	1	150	HSR 22330	—	228.76
3600	1	164	HSR 22360	—	249.55

HI-STRENGTH RANGE OF LINTELS LOAD/SPAN TABLE

UNIFORMLY DISTRIBUTED SERVICE LOADS (kN/m) THE SELF WEIGHT OF THE LINTEL MUST BE SUBTRACTED FROM THE LOAD GIVEN

MANUFACTURE SIZE TO ORDER	SECTION	HSR15	HSR22	HSS15	HSR21	HSS10
	PROFILE (W X H)	100 X 140	100 X 215	140 X 150	140 X 215	100 X 110
	CLEAR SPAN	MAXIMUM SERVICE LOAD IN kN/m (IN ADDITION TO SELF WEIGHT)				
900	600	50.29	67.43	63.90	97.17	32.36
1050	750	40.80	55.44	52.54	79.89	26.61
1200	900	34.31	47.05	44.58	67.80	22.58
1350	1050	29.58	40.85	38.70	58.87	19.60
1500	1200	25.99	36.08	34.18	51.99	15.41
1650	1350	23.17	32.29	30.59	46.54	12.34
1800	1500	19.80	29.22	27.42	42.11	10.09
2100	1800	13.80	24.52	19.30	35.01	7.08
2400	2100	10.14	21.11	14.27	25.94	5.21
2700	2400	7.73	16.46	10.94	19.92	3.98
3000	2700	6.07	13.02	8.62	15.74	3.12
3300	3000	4.87	10.53	6.94	12.71	2.50
3600	3300	3.98	8.67	5.69	10.45	2.03
4200	3900	2.77	6.12	3.97	7.35	1.40

Safe working loads indicated are based on the clear span plus 150mm of bearing each end. Our lintels can be cut to length as required.

GUIDANCE NOTES

No assistance from composite brickwork is assumed or included in these figures.

Bearings: minimum bearing length to be 150mm each. Where required provide suitable Padstones. Ensure, however that all bearings are sound.

Where information on self weights of individual units is given this is intended for guidance purposes only. They are subject to change depending upon changes to the raw materials used so it is important to check the actual weights before use if this is a critical factor.

Most clear spans shown above are in increments of 150mm and the safe working loads indicated are based on the clear span plus 150mm of bearing each end. Our lintels are supplied in a standard range of lengths and can be cut to length as required.

The safe working load per metre is the least of the flexural strength, the shear strength or the load that gives a deflection limit of L/325.

Deflection information is available for our full range of lintels, please see Ibstock DoP or contact our technical department.

PLEASE NOTE! Safe working loads indicated are based on the clear span plus 150mm of bearing each end.

Our lintels are supplied in a standard range of lengths and can be cut to length as required. The safe working load per metre is the least of the flexural strength, the shear strength or the load that gives a deflection limit of L/325. Deflection information is available for our full range of lintels, please see Ibstock DoP or contact our technical department.

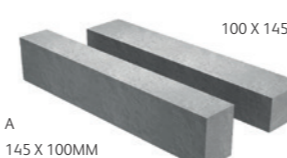
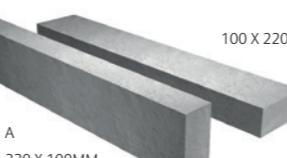

PRECAST LINTELS

TYPE	METRIC (MM)	DESCRIPTION	PACK QUANTITY	PACK WEIGHT (KG)	PRODUCT CODE	SPLIT PRICE EACH (£)	PACK PRICE EACH (£)
A 145 X 100MM 	610 x 145 x 100	2' x 6" x 4"	24	499	LIN 00	19.63	16.36
	735 x 145 x 100	2'5" x 6" x 4"	24	605	LIN 01	22.20	18.57
	965 x 145 x 100	3'2" x 6" x 4"	24	790	LIN 02	25.39	21.09
	1065 x 145 x 100	3'6" x 6" x 4"	24	859	LIN 03	28.69	23.84
	1220 x 145 x 100	4' x 6" x 4"	24	989	LIN 04	32.20	26.81
	1370 x 145 x 100	4'6" x 6" x 4"	24	1114	LIN 05	35.73	29.82
	1525 x 145 x 100	5' x 6" x 4"	24	1243	LIN 06	39.28	32.77
	1675 x 145 x 100	5'6" x 6" x 4"	24	1373	LIN 07	42.81	35.73
	1830 x 145 x 100	6' x 6" x 4"	24	1510	LIN 08	47.23	39.28
	2130 x 145 x 100	7' x 6" x 4"	12	880	LIN 10	54.37	45.31
A 220 X 100MM 	2440 x 145 x 100	8' x 6" x 4"	12	1004	LIN 12	63.58	53.10
	2745 x 145 x 100	9' x 6" x 4"	12	1140	LIN 13	79.40	66.30
	3050 x 145 x 100	10' x 6" x 4"	12	1279	LIN 14	87.30	72.76
	1220 x 220 x 100	4' x 9" x 4"	9	573	LIN 31	48.74	39.12
	1525 x 220 x 100	5' x 9" x 4"	9	720	LIN 32	59.68	49.79
	1830 x 220 x 100	6' x 9" x 4"	9	875	LIN 33	70.86	59.00
	2130 x 220 x 100	7' x 9" x 4"	9	1010	LIN 34	86.91	72.40
	2440 x 220 x 100	8' x 9" x 4"	9	1139	LIN 35	102.08	85.00
	2745 x 220 x 100	9' x 9" x 4"	9	1280	LIN 36	113.70	94.78
	3050 x 220 x 100	10' x 9" x 4"	9	1415	LIN 37	125.52	104.56



PRECAST LINTEL LOAD SPAN

MANUFACTURE SIZE TO ORDER	SECTION	REINFORCEMENT	100 X 145*	145 X 100	PRODUCT CODE
	CLEAR SPAN		MAXIMUM SERVICE LOAD IN kN/m (IN ADDITION TO SELF WEIGHT)		
	610		310	4 No H8	
735	435	4 No H8	58.71	71.63	LIN 01
965	665	4 No H8	30.08	45.30	LIN 02
1065	765	4 No H8	23.79	35.87	LIN 03
1220	920	4 No H8	17.31	26.14	LIN 04
1370	1070	4 No H8	13.24	20.03	LIN 05
1525	1225	4 No H8	10.35	15.69	LIN 06
1675	1375	4 No H8	8.35	12.69	LIN 07
1830	1530	4 No H8	6.82	10.40	LIN 08
2130	1830	4 No H10	6.20	9.65	LIN 10
2440	2140	4 No H10	4.55	7.12	LIN 12
2745	2445	4 No H10	3.47	5.47	LIN 13
3050	2750	4 No H10	2.71	4.31	LIN 14

PRECAST RANGE OF LINTELS LOAD/SPAN TABLE

Uniformly distributed service loads (kN/m).

The self weight of the lintel must be subtracted from the load given.
* Height x width. Safe working loads indicated are based on the clear span plus 150mm of bearing each end. Our lintels can be cut to length as required.

PRECAST LINTEL LOAD SPAN

MANUFACTURE SIZE TO ORDER	SECTION	REINFORCEMENT	100 X 220*	220 X 100	PRODUCT CODE
	CLEAR SPAN		MAXIMUM SERVICE LOAD IN kN/m (IN ADDITION TO SELF WEIGHT)		
	1220		920	4 No H8	
1525	1225	4 No H8	11.21	23.48	LIN 32
1830	1530	4 No H8	7.34	19.12	LIN 33
2130	1830	4 No H10	7.24	18.89	LIN 34
2440	2140	4 No H10	5.28	16.27	LIN 35
2745	2445	4 No H10	4.00	14.29	LIN 36
3050	2750	4 No H10	3.10	12.00	LIN 37

Padstone

THE NAME THAT CARRIES MORE WEIGHT

- Engineered to perform
- Complements Ibstock's lintel range
- Made from high strength dense concrete
- Ready to use and saves time on-site

The concrete used in the manufacturing of padstones conforms to a compressive strength class C40/50.

Ibstock padstones can be used in any orientation.

Our PAD marked padstones offer increased margin opportunities and safety by helping you to sell the right product for the right application.

PADSTONE		Strongcast Original					
	METRIC (MM)	IMPERIAL	PACK QUANTITY	PACK WEIGHT (KG)	PRODUCT CODE	SPLIT PRICE EACH (£)	PACK PRICE EACH (£)
	215 x 140 x 102	9" x 5 1/2" x 4"	12	84	PAD 01	11.03	9.17
	300 x 140 x 102	12" x 5 1/2" x 4"	12	108	PAD 02	13.61	11.42
	440 x 140 x 102	18" x 5 1/2" x 4"	12	168	PAD 03	17.84	14.82
	600 x 140 x 102	24" x 5 1/2" x 4"	12	228	PAD 04	23.55	19.63
	440 x 140 x 140	18" x 5 1/2" x 5 1/2"	12	228	PAD 05	22.82	19.01
	215 x 140 x 215	9" x 5 1/2" x 9"	12	168	PAD 06	19.12	16.00
	440 x 140 x 215	18" x 5 1/2" x 9"	12	360	PAD 07	31.21	25.98
	380 x 140 x 215	15" x 5 1/2" x 9"	12	300	PAD 08	26.20	21.81
	440 x 215 x 215	18" x 9" x 9"	12	588	PAD 09	44.10	36.73
	215 x 215 x 102	9" x 9" x 4"	12	120	PAD 11	16.09	13.53
	440 x 215 x 102	18" x 9" x 4"	12	273	PAD 12	24.13	20.13
	330 x 215 x 102	13" x 9" x 4"	12	192	PAD 13	20.18	16.81
	100 x 65 x 225	4" x 2 1/2" x 9"	12	48	PAD 15	9.55	7.93

CORNER PADSTONE		Strongcast Original					
	METRIC (MM)	IMPERIAL	PACK QUANTITY	PACK WEIGHT (KG)	PRODUCT CODE	SPLIT PRICE EACH (£)	PACK PRICE EACH (£)
	215 x 215 x 215 x 100	9" x 9" x 9" x 4"	1	25	PAD 21C	—	20.27
	300 x 300 x 215 x 100	12" x 12" x 9" x 4"	1	34	PAD 22C	—	25.17
	440 x 440 x 215 x 100	18" x 18" x 9" x 4"	1	59	PAD 23C	—	38.94
	600 x 600 x 215 x 100	24" x 24" x 9" x 4"	1	75	PAD 24C	—	55.10

i Add value to your sales – locate lintels and padstones together in your yard.



Fireplace lintel

FIREPLACE LINTEL		Strongcast Original					
	METRIC (MM)	IMPERIAL	PACK QUANTITY	PACK WEIGHT (KG)	PRODUCT CODE	SPLIT PRICE EACH (£)	PACK PRICE EACH (£)
	865 x 145 x 100	2'10" x 6" x 4"	12	284	LIN 41	39.28	32.75



Suspended beam and block floor

Prestressed beam and block flooring is a popular flooring solution, which is in significant growth.

WHY STOCK CONCRETE FLOOR BEAMS?

- Beam and block flooring is a highly practical solution for ground and upper floors, quick and easy to install in all weather conditions without the need for special skills
- Immediately creates a safe, level working platform
- 70% of all new build ground floors are constructed using a beam and block system
- For the homeowner, a beam and block floor helps to reduce noise transmittance through floors
- Concrete floor beams provide a high level of thermal insulation and fire resistance
- A standard or wide beam solution is well suited to open plan designs with large span requirements – An excellent alternative to concrete slab and timber floors
- Maintenance free
- Easy to handle

WHY STOCK IBSTOCK FLOOR BEAMS?

- UK's largest prestressed concrete manufacturing national supplier facility
- Ensured continuity of supply with no impact on lead time
- Full suite of transport solutions
- In-house technical support and design service
- Manufactured in 50mm increments, reducing the need for cutting on-site
- BIM enabled to Level 2 to comply with specifier's requirements

Two solutions

We have two beam solutions; standard and wide, with two height options in each, meaning the two solutions can be used together ensuring the most economical construction options.

STANDARD BEAM

Standard floor beams primary use is for housing and residential construction.

- Span up to 6m
- Available from 600mm to 6m
- Available in 50mm increments

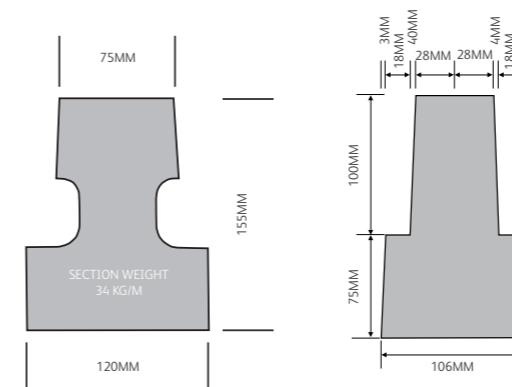

Standard beam from Sittingbourne – South

Standard beam from Dewsbury – North

WIDE BEAM

Wide floor beams can span longer distances and support greater imposed loads, making them more suited to commercial projects, as well as housing and residential.

- Span up to 6.75m
- Lighter choice commercial solution
- Wide beams mean a faster installation due to fewer units to lift, simpler layout and less grouting
- Available from 4m

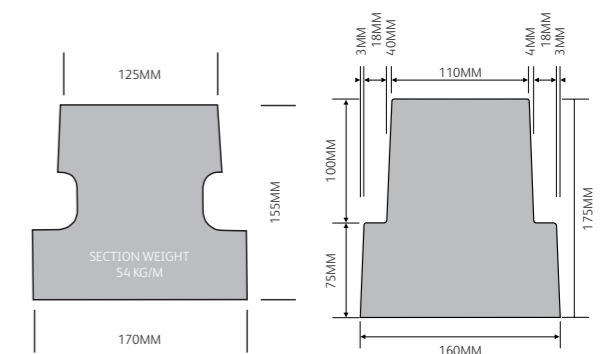

Wide beam from Sittingbourne – South

Wide beam from Dewsbury – North

How to stock Istock floor beams

BEAMS IN STOCK

- Core range available in easy to sell beam packs
- Beams meet the requirements of 85% of all merchant sales
- Beams are strapped and clearly labelled making them easy to store, transport and re-order

General orders/enquiries:

T: 0333 999 2220

F: 01795 433 599

E: supreme.beamsales@ibstock.co.uk

BEAM PACKS					
TYPE	DIMENSIONS (MM)	DESCRIPTION	PACK QUANTITY	PACK WEIGHT (KG)	PRODUCT CODE
Beam pack	3000	T-beam	8	822	TBMPCK 300
	3600	T-beam	8	985	TBMPCK 360
	4200	T-beam	8	1148	TBMPCK 420
	4800	T-beam	8	1312	TBMPCK 480
Coursing slips	390 x 100 x 40	—	1	3.5	COS 002
Brickslips	172 x 140 x 40	Wide	204	469	COS 140
	172 x 90 x 40	Half pack	204	290	COS 204
	172 x 90 x 40	Full pack	408	570	COS 408
Closure block	210 x 140 x 100	Half width	1	6	TCL 210
	440 x 140 x 100	Standard	1	14	TCL 440

Merchant design and supply solution

Beams are ordered through merchants for large scale projects with greater technical requirements.

Design and quotation service available to assist with technical specifications within 24 hours of receipt of enquiry.

Full quotations available which can include detailed layout drawings. Full structural calculations can be supplied following approval of the drawings for building control.

Design and supply enquiries:

T: 0333 999 2220

F: 01795 433 599

E: supreme.beamsales@ibstock.co.uk

Technical helpline:

T: 0333 999 2220

Transport Enquiries:

T: 0333 999 2220

Floor beam load span table

www.ibstock.co.uk



1. Merchant receives customer enquiry



2. Merchant sends in a drawing and/or enquiry form to Istock design team



3. Istock quotation returned to merchant in 24 hours



4. Merchant sends drawing back to customer with price



5. Beams delivered from Istock direct to site within 5-7 days (but generally before)

How to stock Istock floor beams

BEAM ASSOCIATED PRODUCTS

TYPE	UNITS PER PACK	PACK WEIGHT (KG)	PRODUCT CODE	PACK PRICE EACH (£)
Coursing Slips 390 x 100 x 40	1	3.5	COS 002	1.39
Brickslip 172mm x 140mm x 40mm	204	469.2	COS 140	203.09
Brickslips (Half Pack 204) 172x90x40	204	290	COS 204	133.20
Brickslips (Full Pack 408) 172x90x40	408	570	COS 408	230.78
Closure Block 215 x 140 x 100	1	5.4	TCL 215	1.84
Closure Block 440 x 140 x 100	1	11.4	TCL 440	2.51
Blue-Black Plastic Air Brick 213x70x60	1	0.117	PAB 1BB	1.69
Brown Plastic Air Brick 213x70x60	1	0.117	PAB 1BR	1.69
Buff Plastic Air Brick 213x70x60	1	0.117	PAB 1BU	1.69
Terra Plastic Air Brick 213x70x60	1	0.117	PAB 1TE	1.69
Plastic Void Vent and Blue-Black Air Brick Set	1	0.54	PAB 2BB	4.99
Plastic Void Vent and Brown Air Brick Set	1	0.54	PAB 2BR	4.99
Plastic Void Vent and Buff Air Brick Set	1	0.54	PAB 2BU	4.99
Plastic Void Vent and Terra Air Brick Set	1	0.54	PAB 2TE	4.99
Plastic Extension Sleeve For Void Vents	1	0.175	PEX 002	4.99
Plastic Telescopic Void Ventilators	1	0.426	PVV 001	3.24
T-Beam Butt Plate 100mm	1	0.861	TBB 125	13.52
T-Beam Butt Plate 140mm	1	0.907	TBB 126	13.52
WLK Ceiling Clips	50	2.6	WLK 001	0.70

COURSING SLIPS

These slips save a split brick course at side bearing or between end bearing.

CEILING CLIPS

Used with battens to facilitate fixing of ceiling.

BUTT PLATE

Designed to increase bearing locally where beams clash on 100mm or 150mm thick supporting walls at upper floor levels.

BRICK SLIPS

For finishing the floor onto load-bearing walls, parallel edges and between the end of the beams.

PLASTIC VOID VENTS

Designed for ventilating the void below suspended ground floors. Vertical and horizontal extension sleeves are available.

CLOSURE BLOCKS

Fit between the beams on the bearing ends. This saves time cutting bricks or blocks.

AIR BRICKS

Air bricks to be used in conjunction with the telescopic void vent.

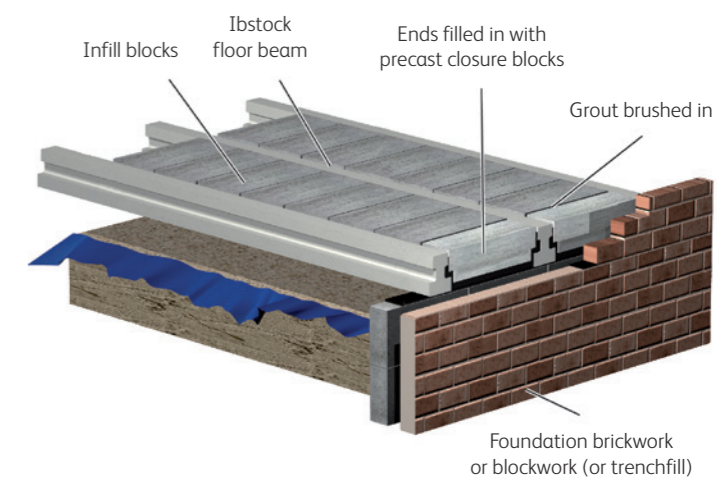



SUSPENDED BEAM AND BLOCK FLOOR

Ensure that the ground beneath the floor is cleared of top soil and vegetation. No oversite concreting is required.

VENTILATION

Provision should be made for a void beneath the floor, the depth of which should be at least 150mm but may vary depending on site conditions. To meet Local Authority and NHBC requirements, the void should be ventilated. Ventilation openings should be placed to enable the free flow of air to the complete under floor area. Ventilators should be placed frequently enough to the perimeter of the building to give suitable ventilation. Istock supply plastic telescopic void ventilators with a range of coloured plastic air bricks.

INSTALLATION

It is essential that the floor beams be handled and stacked the correct way up, they should be lifted as close to the ends as possible and no damaged beams should be used in the installation. It is important that all mortar in the preceding work is adequately cured, having enough strength to give support to the floor being installed.

Ensure that all mortar and debris is removed from the bearing points and they are level and true. Generally a DPC should be placed over all bearings before laying a ground floor. Beams should have a nominal bearing of 100mm on the masonry.

Please adhere to starting beams on our working drawings and set beams out bay by bay. Take note of critical partition walls etc. Ensure all beams are parallel and that there is a nominal 18mm bearing for the block.

Install closure blocks after laying infill blocks.

The floor should be completed as soon as possible by brushing in a wet grout mix of 1:3 cement and sharp washed sand, a stiffer mix of the same proportions should be used to fill any double or multiple beams, these joints should be "hard packed". The floor should be cleaned and wetted prior to grouting to enable grout to penetrate and to provide a firm construction. Prestressed floor beams have an upward camber. The camber should be considered especially on larger spans and / or when non-screed finishes are specified. A levelling screed could be incorporated.

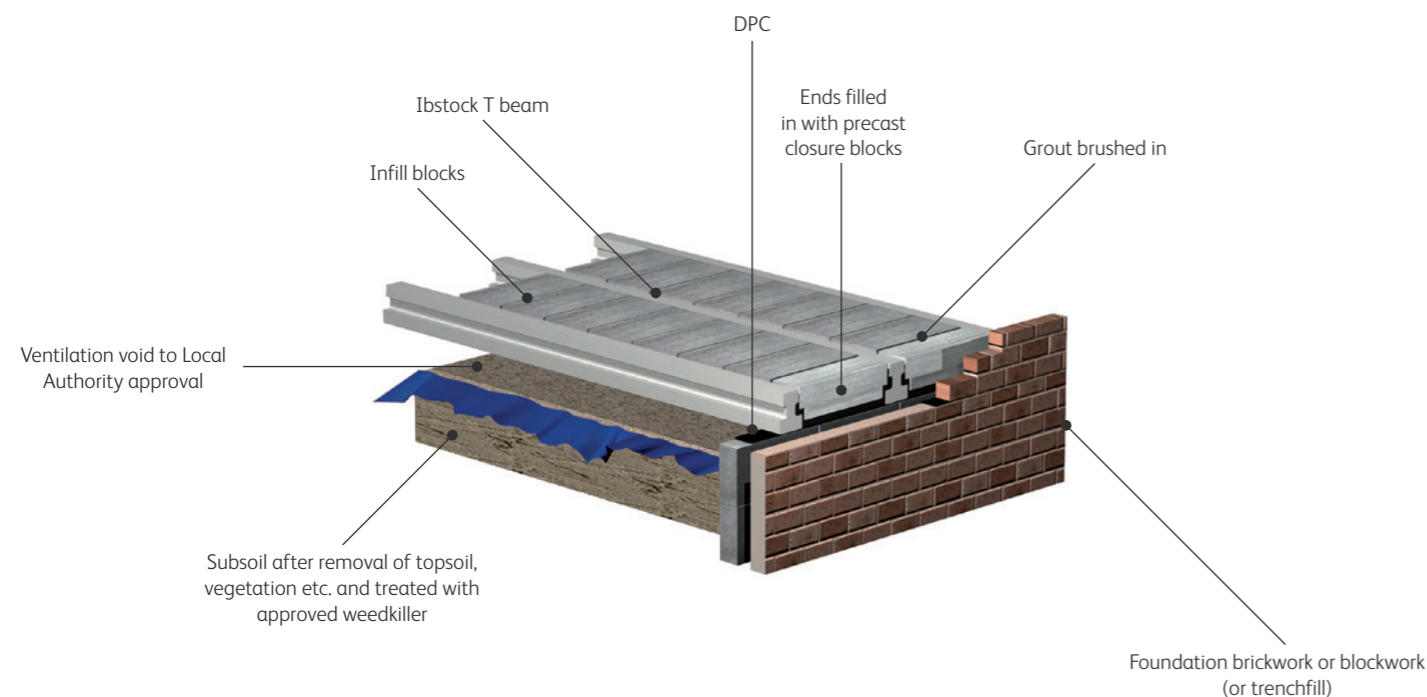

Note! Closure blocks should not be used to space the beams; they should be installed using mortar when all blocking out is complete.

DOMESTIC GARAGE USE

When a beam and block floor is used in a domestic garage or similar application where high concentrated loads are evident, a reinforced screed must be applied directly to the top of the beams and blocks. The screed should have a compressive strength of 21N/mm² with light steel mesh reinforcement, such as an A98 steel mesh.

BEAM PROPERTIES AND STRUCTURAL CALCULATIONS

Where the design layout drawings have been produced by Istock then full structural calculations can be provided upon request.

Beams on angles supplied to site at standard lengths to be cut to suit by others.

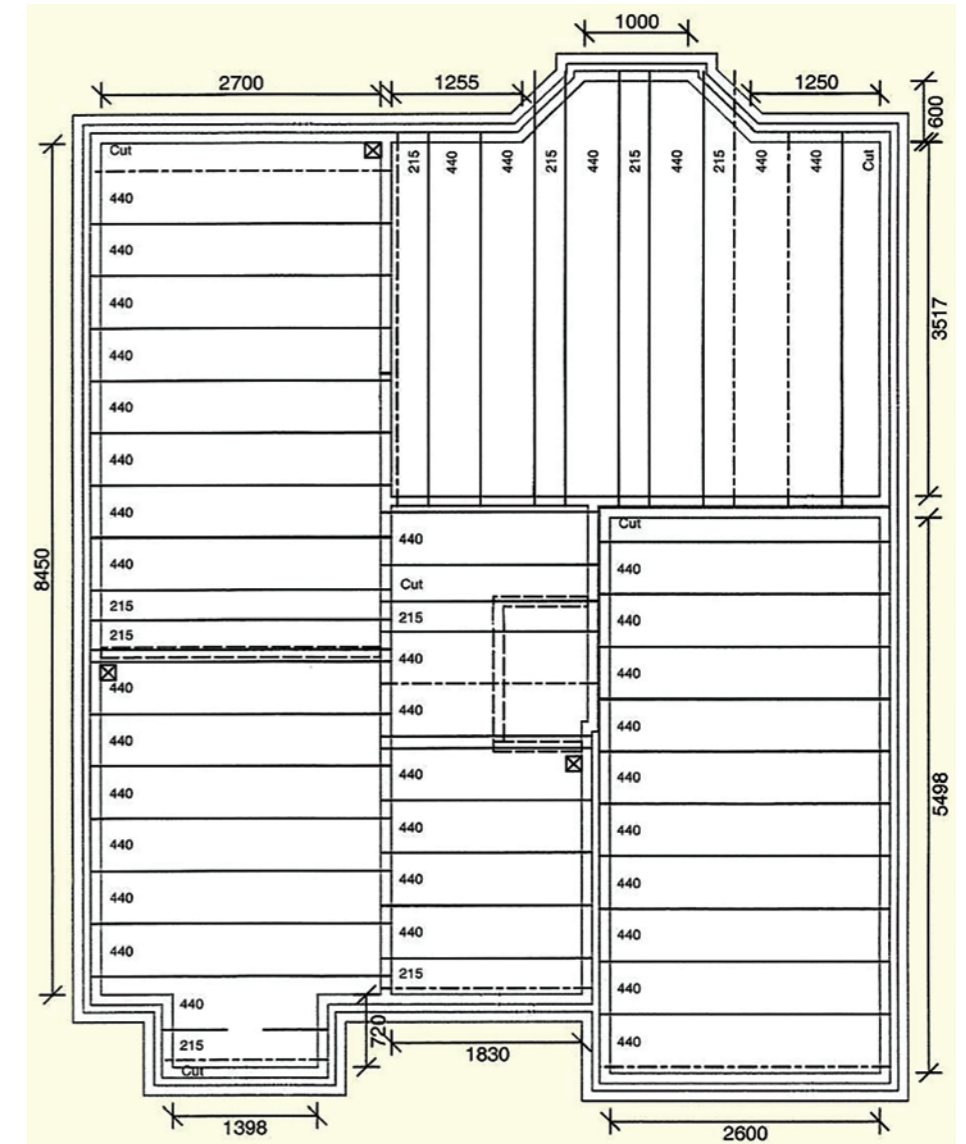

Plan shown here using standard face size 440 x 215 infill block (with cuts when required as shown).

All measurements in mm.

1. Beams supported on inner leaf of cavity wall. Closure block bedded.

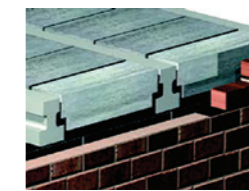

4. Coursing slip with block out from beam into adjacent support wall bedded on coursing slip.



2. Two beams grouted together to support block partition.

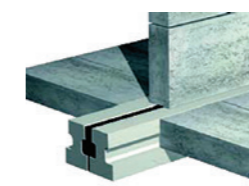

5. Closure block on internal support.

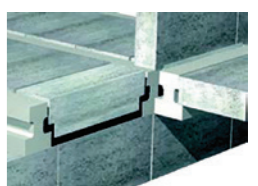

3. Beam adjacent to support wall and grouted solid.



6. Shared bearing on internal support wall less than 200mm thick.

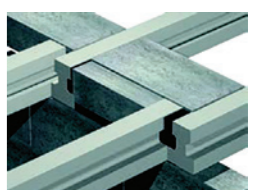

FLOOR BEAM PROMISE

10 STEPS TO SELLING MORE TOGETHER



1: WE WILL RESPOND TO ENQUIRIES WITHIN **1 WORKING DAY**.

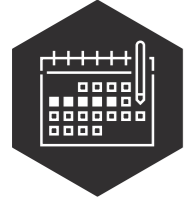

2: WE WILL ENSURE A RELIABLE DELIVERY ON TIME, IN FULL WITHIN **5-7 WORKING DAYS**.



3: WE WILL ENSURE **CONTINUITY OF SUPPLY** WITH NO IMPACT ON LEAD TIMES.



4: ALL DELIVERIES WILL BE GIVEN VERBAL CONFIRMATION **48 HOURS** BEFORE THE DELIVERY DATE.



5: WE WILL HOLD A **FULL RANGE** OF STANDARD FLOOR BEAMS IN STOCK AT ALL TIMES.



MARKET LEADING SERVICE OR YOUR MONEY BACK*

*Must be claimed within 7 days of service. Subject to investigation and review and can only be requested once by any person / company. Our decision is final.

GENERAL ORDERS / ENQUIRIES / FLOOR BEAMS DESIGN & SUPPLY ENQUIRIES:

Phone: 0333 999 2220
Email: beamsales@supremeconcrete.co.uk

www.ibstock.co.uk



6: WE WILL PROVIDE A **CONSISTENT, HELPFUL** EXPERIENCE AT ALL OF OUR CUSTOMER TOUCH POINTS.



7: WE WILL **LISTEN TO OUR CUSTOMERS** AND BY REVIEWING OUR SATISFACTION SURVEYS, WE WILL DELIVER A GREAT CUSTOMER EXPERIENCE.



8: ALL CALLS WILL BE ANSWERED WITHIN **6 RINGS**.



9: WE WILL ALWAYS **VALUE** YOUR BUSINESS.



10: WE WILL ALWAYS PROVIDE **DEDICATED CONTACTS** FOR CUSTOMER SERVICE, DESIGN, TECHNICAL AND TRANSPORT ENQUIRIES.



Delivery

DELIVERY TO DEPOT

Free delivery for fencing, building or padstones over 5 tonnes.
Free delivery for prestressed lintels, beams or padstones over 3 tonnes.
We are happy to deliver smaller loads at a small charge of £80 to cover costs.

COLLECTIONS

Bedford, Barnwell, Northwich and Sittingbourne - Mon-Fri 08:00-15:30hrs.
Booking may be required.
Collection discount may be available. Collections are limited to vehicle type. Contact sales office for more information.

PACKING

To ensure our products reach you in the best possible condition, goods are supplied on free-of-charge pallets and bearers.

LOAD DISCOUNTS

To keep costs as competitive as possible, we apply the following discounts* to pass on any savings we can make to our customers.

- 2% for 14 to 26.9 tonnes
- 4% for 27+ tonnes

*Load discounts do not automatically apply for customers on bespoke terms.

PAYMENTS

All prices are subject to VAT at the current rate.

DIRECT TO SITE DELIVERIES

- Crane offload - Lintels £95 per delivery; Floor Beams £90 per delivery.
- Rigid vehicle - Lintels £105 per delivery; Floor Beams £125 per delivery.
- Please contact the relevant sales office

Contact

IBSTOCK FENCING, BUILDING AND LINTEL PRODUCTS

T: 0333 999 2220 – option 1
F: 01487 833 305
E: supreme.sales@ibstock.co.uk

PRESTRESSED FLOOR BEAMS GENERAL ORDERS/ENQUIRIES

T: 0333 999 2220 – option 1, then 2
F: 01795 433 599
E: supreme.beamsales@ibstock.co.uk

FLOOR BEAM DESIGN AND SUPPLY ENQUIRIES

T: 0333 999 2220 – option 1, then 2
F: 01795 433 599
E: supreme.beamsales@ibstock.co.uk

TECHNICAL HELPLINE

T: 0333 999 2220

TRANSPORT ENQUIRIES

T: 0333 999 2220

STEPOC AND KEYSTONE

T: 0333 999 2220 - option1, then 2
F: 01795 433 599
E: supreme.beamsales@ibstock.co.uk

BESPOKE PRODUCTS AND SERVICES

T: 0333 999 2220
E: supreme.enquiries@ibstock.co.uk

