



AUBRILAM
— SPACE COMES ALIVE —

AUBRILAM

Making cities unique, beautiful and sustainable.



At its essence, space is an infinite expanse.
It reveals its identity and personality when inhabited.

For over 40 years, we have been enhancing outdoor spaces.

New economic and environmental challenges naturally drive us to reinvent our craft, solutions and products every day.

A space is dynamic, coming to life when people inhabit it. We use materials that are both vibrant and sustainable to bring meaning and beauty to living areas.

Our collections are designed to serve both the spaces and their inhabitants. Each product finds its place in the landscape, fulfilling a specific purpose.

Summary

Introduction



Our identity
06



Installations
08



Our history
10



Thinking sustainably
12



Wood
14



Materials
16-19



AUBRILAM HTE
20



Our process
22



Maintenance
24



Standards
26



Personalisation
28



Customization
30



Planning
32



The color chart
34-47



Product offering
48

Furniture



Seating
50 to 89



Tables
90 to 93



Sets
94 to 105



Planters
106 to 113



Litter bins
114 to 127



Ashtrays
128 to 131

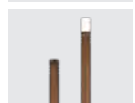

Bollards
132



Bike rack
134



Barriers
136 to 139



Wind protection
140



Shelters
142 to 149

Lighting



Lighting points
150



Responsible lighting
188



Dark Sky
190



BEGA BugSaver®
192



Control solutions
194

Lighting bollards



Notche
154 to 157



Skala
158



Solina
160 to 163



Sahari
164 to 167



Sensy
168



Moshi
170 to 175

Light building elements



Notche
176



Skala
178



Solina
180



Sahari
182



Sensy
184 to 187

Poles



Skala
196



Moshi XL
198



Silea XL
200



Sumu XL
202



Dôme XL
204



Stratos
206



Capella
208



Italic
210

Accessories



Brackets
212 to 214



Extensions
214



Ceno supports
215

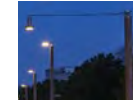

Special mountings
216



Our identity

Who we are

Since our founding in 1978, we have been committed to meeting our customers' needs with originality, authenticity and expertise. We remain true to our core values: respect for the environment, innovation and product quality.

Today, AUBRILAM, part of the BEGA group, continues to grow with this shared philosophy of creating high-quality products that stand the test of time.



What we do

We provide a comprehensive range of products for urban spaces and restaurant terraces. Additionally, we specialize in creating customized solutions to meet your project's unique requirements.

We design and develop our product ranges, manufacturing them in our dedicated workshops. Our expertise and craftsmanship are dedicated to every stage of your project, from design through to implementation.

Our signature

Wood is our primary raw material. Durable, eco-friendly and resilient, it infuses spaces with warmth and character.

In our workshops, we transform wood into distinctive pieces that elevate living spaces and improve user comfort.

AUBRILAM, space comes alive.



Our global presence

Our first facility in Brioude, France, has been transforming wood for over 45 years. Over the decades, we have refined our expertise and modernized our production tools, now housed in two state-of-the-art sites.

These locations oversee the entire manufacturing process, from receiving raw materials to shipping finished products. An outdoor showroom showcases our products in real-world settings.

To support our expansion in America, we opened a new BEGA group production site in Broomfield, Colorado, in 2023.

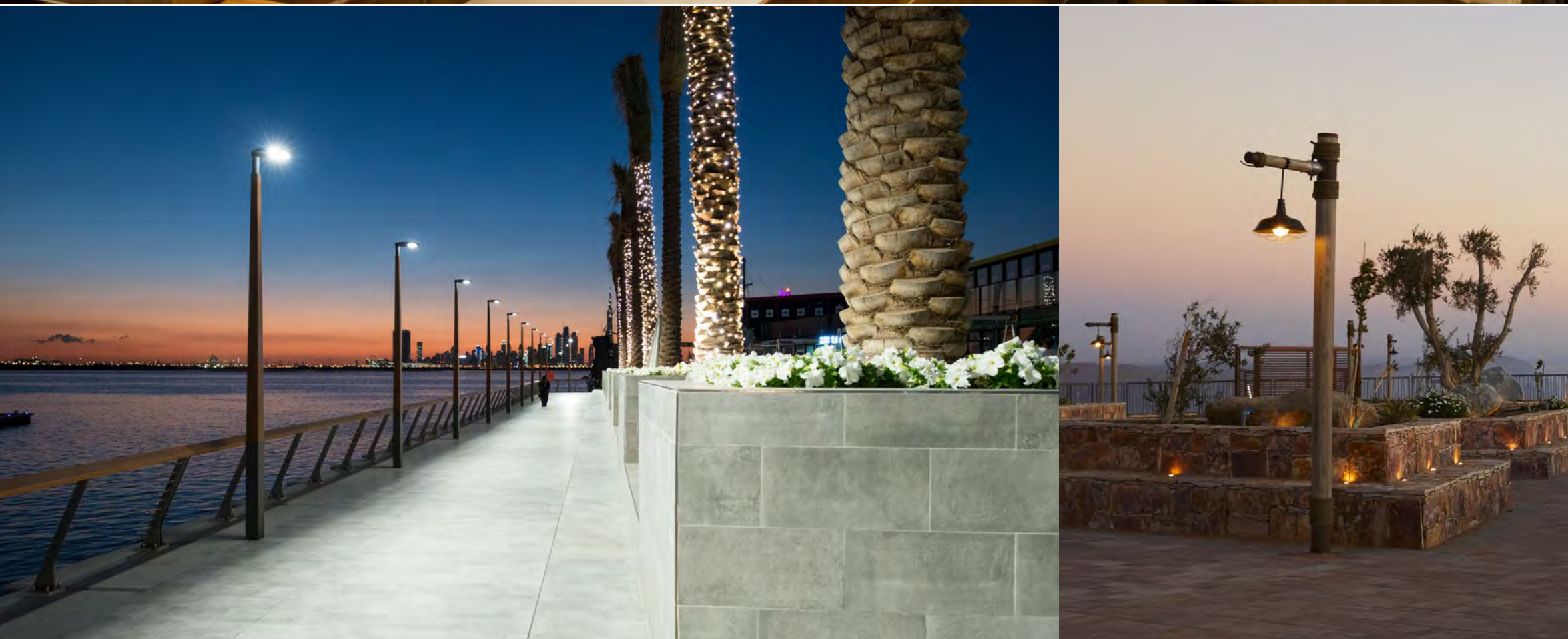

Our commercial presence

Through our sales network and partners, we reach over 100 countries worldwide.

Our history



1978

Over 45 years
Our company creation. Wood, our primary raw material, is vibrant and sustainable.

1992

McDonald's
Our first terrace is inaugurated in Aurillac, Cantal.

1996

Great heights
We manufacture glulam wood poles up to 24 meters high.

2002

Expansion
We expand and modernize our production facilities.

2009

The LCA method
Life Cycle Analysis. We calculate the environmental impact of each of our products.

2010

CE marking
AUBRILAM leads the normative market with its wood-metal poles, the only ones to bear the CE marking.

2014

Global reach
We provide comprehensive product and service solutions worldwide.

2018

Connectivity
Our furniture integrates smart solutions for user convenience, including charging points, Wi-Fi and lighting control.

2020

BEGA
AUBRILAM joins the BEGA group.

2023

Modernization
We expand and modernize our production site, unveiling a new 2,000 m² showroom. We are accelerating our growth in the Middle East and across the Americas.



Our partnership with McDonald's

- over 30 years of partnership;
- equipping over 600 terraces annually;
- supporting regions: Europe, Middle East/Africa, South America and North America.

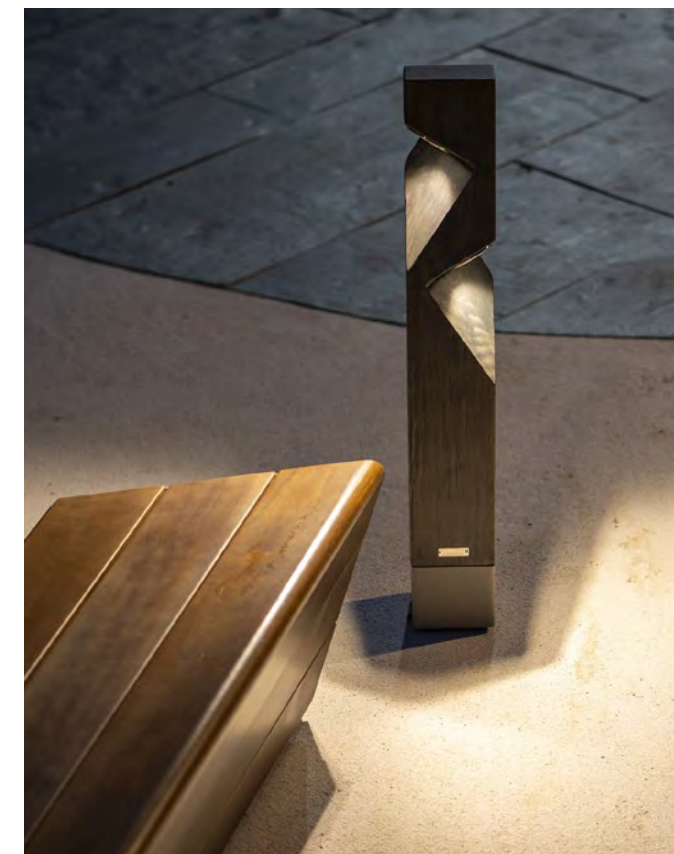

Today

We continue to bring our expertise to offer high-quality, sustainable and customized solutions. Innovation is at the heart of our approach.

Tomorrow

Our goal is to keep making cities more beautiful and pleasant to live in.



Thinking sustainably

Thinking sustainably means creating eco-friendly products that harmonize with living spaces, with understated designs that are crafted to blend in naturally.

Sustainable by design

At AUBRILAM, our philosophy revolves around using durable materials integrated optimally into our products. Responsibly meeting needs is paramount to us. With our eco-design approach, we give materials a new life. Designing products with the life cycle of our materials in mind is central to our ethos.

For the past 45 years, wood has been at the heart of our environmental approach in our wood-metal hybrid products. Wood, with its positive environmental footprint, captures and stores CO₂ during its growth, absorbing 1 tonne of CO₂ per 1 cubic meter of wood.

For our lighting poles, we use Scots pine sourced from sustainably managed forests. This heartwood is harvested from carefully selected trees. For our furniture, we opt for Accoya®, an exceptionally durable modified wood guaranteed for up to 50 years of outdoor use. Healthy, sustainably sourced and fully recyclable, Accoya® perfectly aligns with our eco-friendly approach. Moreover, 80% of our aluminum comes from recycled sources.

Using wood as a structural material in our poles instead of steel and aluminum significantly reduces the environmental footprint of our products during manufacturing. Furthermore, we continually refine our designs and processes to offer even more environmentally friendly and durable products.

Optimization and innovation

We meticulously calculate the dimensions and thicknesses of our wooden components to optimize the use of raw materials while ensuring the product's durability in its installation location. Since 2006, this approach has been integral to the design of our laminated wood poles, as evidenced by our AUBRILAM HTE label.

In our workshops, we consistently enhance our processes and tools to reduce energy consumption from our machinery and minimize production waste. We recover and repurpose wood shavings and unused scraps in recycling initiatives. Quality management is a key focus across all our sites to enhance our environmental performance.

Thinking sustainably means offering landscaping solutions that make living spaces beautiful, enjoyable and comfortable in the long term. Our products are designed with this purpose in mind, paying attention to every detail. Each piece is carefully designed and adjusted to give the product a cohesive and harmonious silhouette, seamlessly integrating into spaces and standing the test of time.

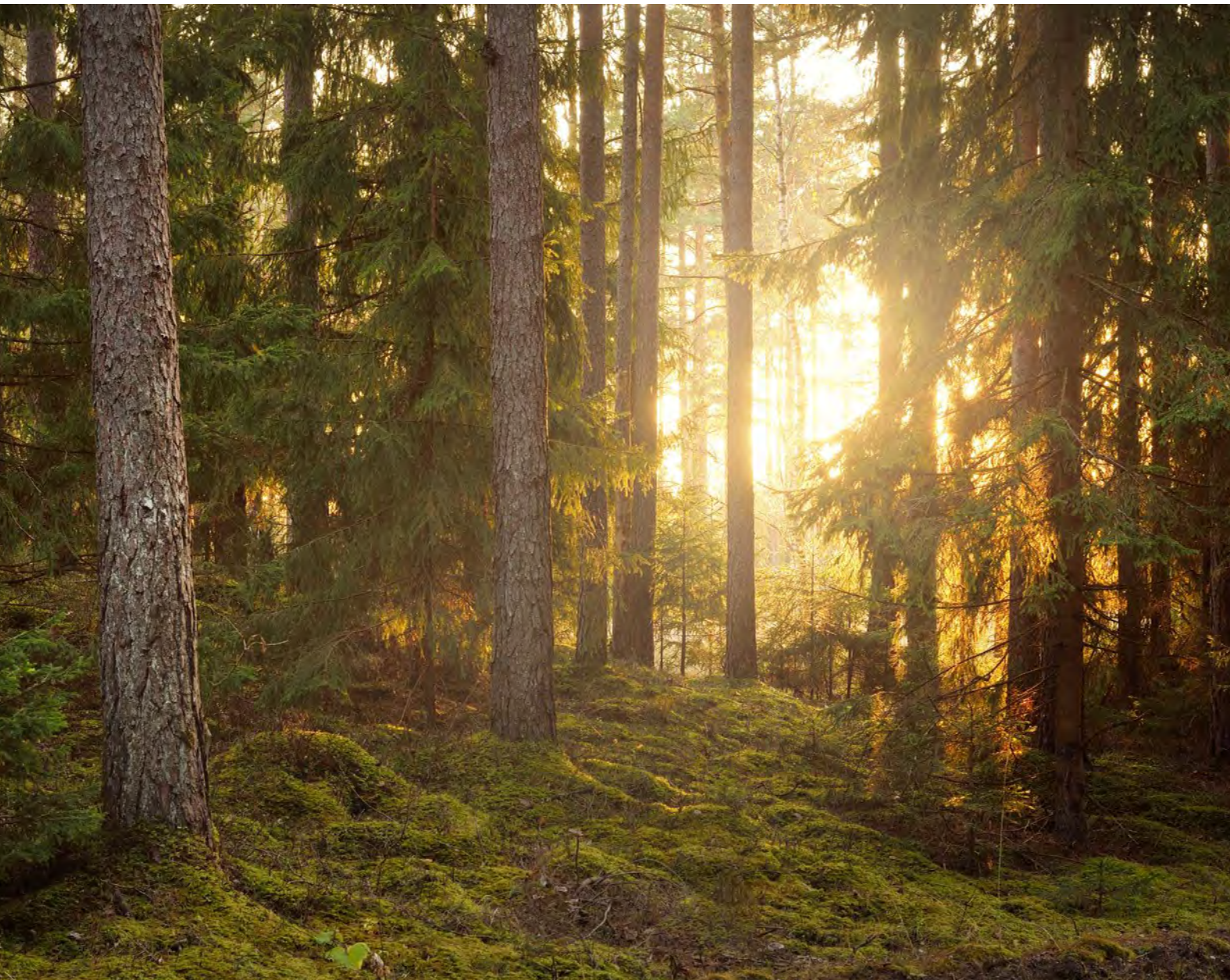

Optimizing a project's environmental performance

Since 2006, we have adopted a Life Cycle Assessment (LCA) approach, compliant with ISO 14040 and 14025 standards, to assess and mitigate the environmental impacts of our products during manufacturing. This analysis allows us to generate detailed reports outlining the environmental footprint of each of our poles.

This initiative is part of a comprehensive approach aimed at:

- analyzing the factors responsible for environmental degradation throughout the product life cycle;
- calculating the environmental impact of each product;
- objectively comparing our results with those of metal poles;
- enhancing project and product environmental performance through eco-design.

This approach enables us not only to undertake eco-responsible projects but also to offer our clients specialized environmental expertise tailored to their projects based on the selected products.

Wood, our signature

Wood, our primary raw material, is incorporated into the majority of our products. Beyond meeting our standards for durability and environmental preservation, it possesses unique qualities that give it such distinctive character.

Soft, noble and warm, it adds a soulful dimension to each of our projects. Its textures, colors, and interplay of light make it an unparalleled aesthetic feature.

Scots pine

Originating from Finland, its slow growth results in wood with very fine and uniform growth rings. These sought-after qualities are only achievable due to the unique climate in these regions.

This Scots pine is harvested from carefully selected trees, with only heartwood used, naturally classified as grade 3 (use class).

We use this wood for our structural elements such as light poles, incorporating a finishing process with wood stain that both colors and protects the wood surface during manufacturing.

Accoya® wood

Accoya® wood is derived from the acetylation of sustainably sourced fast-growing woods, making it exceptionally durable, healthy and environmentally friendly. Impervious to decay and highly water-resistant, it boasts a very low carbon footprint and is fully recyclable.

We use Accoya® wood to craft our furniture pieces and lighting bollards. We apply our wood stain finish to enhance its aesthetic appeal, although it can also be used in its natural state to meet specific project requirements.



High-pressure compact laminate

Our high-pressure compact laminate panels are made of sustainably sourced wood, ensuring they are environmentally friendly. They are resistant to all weather conditions and easy to maintain, making them ideal for crafting tabletops, seating and other furniture components.

The wood-like finishes we've chosen blend seamlessly with our range of wood stains, creating cohesive and stylish product lines.

Materials

Scots pine glued laminated timber (glulam)

Characteristics

Constructed from multiple layers of heartwood, untreated, harvested from mature trees in sustainably managed and PEFC-certified forests. ACERBOIS-GLULAM certified material.

Benefits

High durability and outdoor performance (Class 3). Strong mechanical resistance to bending, compression and impacts.

Applications

We use this material for creating light building elements and poles up to 16 meters in height.

Accoya® modified wood

Characteristics

Accoya® is wood modified through a patented acetylation process, transforming sustainably sourced and certified timber. It holds FSC® certification and Cradle to Cradle Certified® Gold status.

Benefits

Accoya® offers exceptional dimensional stability and resistance to insects and fungi (Class 4). It is incredibly durable, with a 50-year guarantee above ground and a 25-year guarantee when in contact with soil or water.

Applications

We use this material for our urban furniture and lighting bollards.

High-pressure compact laminate (HPL)

Characteristics

HPL panels are composed of natural wood fiber strips impregnated with synthetic resins. Primarily made of wood processed into "kraft paper," they come from sustainably managed and certified forests (FSC and PEFC). These panels also carry the 'Biosourcé' (Organically Sourced) Product label.

Benefits

Exceptionally weather-resistant, HPL is highly durable against light, scratches and impacts. Easy to clean.

Applications

We incorporate HPL into our designs for terrace and urban furniture.

Molded plywood

Characteristics

Components made from sheets of sustainably sourced beech wood from PEFC-certified forests. Outdoor durability tested and validated by CRITT Bois, and UV resistance validated by CNEP.

Benefits

Exceptionally weather-resistant, HPL is highly durable against light, scratches and impacts. Easy to clean.

Applications

We use this material for crafting curved furniture components.

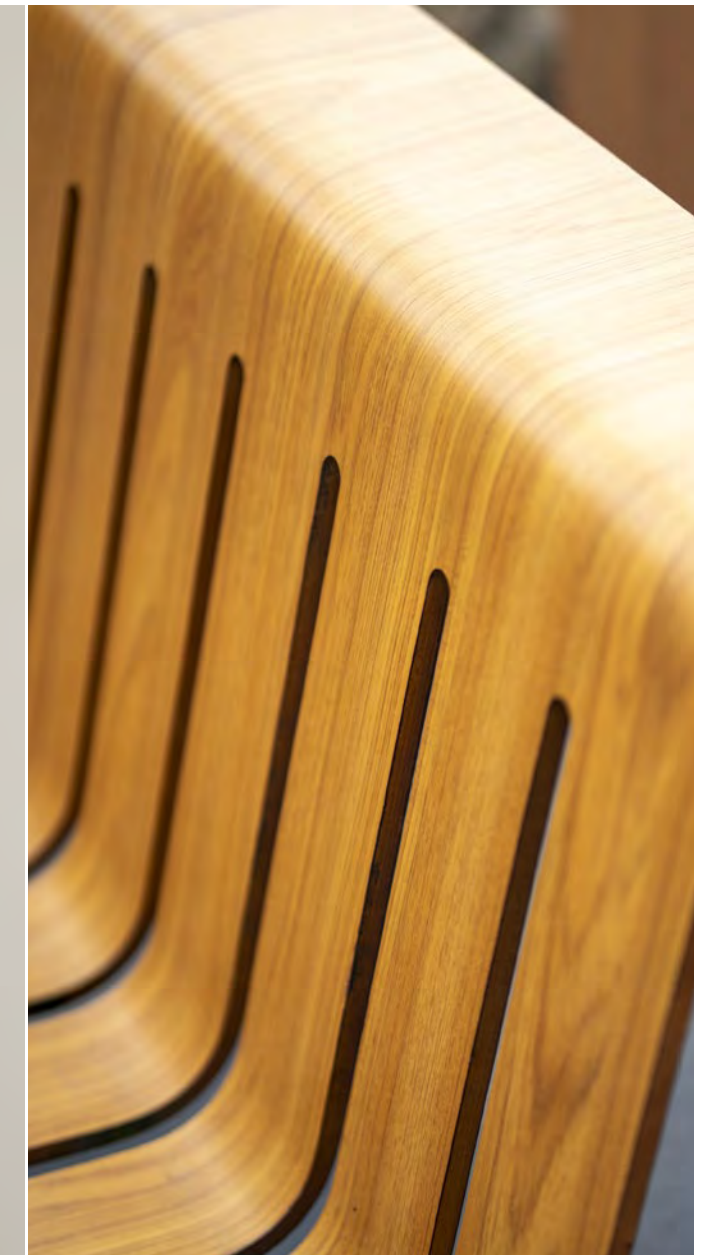
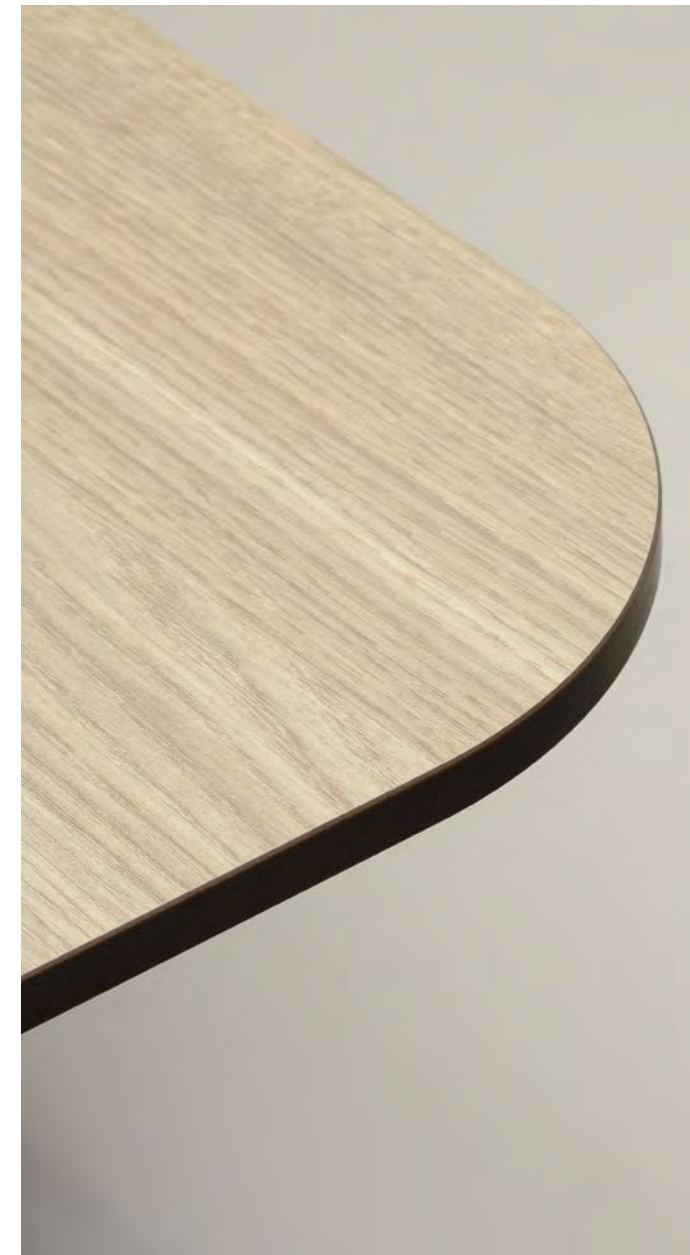

Materials

Aluminum

Characteristics

This malleable material is resistant to oxidation and very lightweight. It is fully recyclable without losing its properties. Recycling it only requires 5% of the energy used in its original production. It undergoes a polyester powder coating.

Benefits

Lightweight and corrosion-resistant. High-quality component finishing.

Applications

We use this material for casting, building elements and other connecting components.

Steel

Characteristics

Durable material with elasticity allowing deformation without breaking. It undergoes a polyester powder coating.

Benefits

Hardness and high resistance to mechanical stress. Ideal for creating large or tall structures.

Applications

We use this material for pole bases and light building elements. We also use it for structural components in our furniture.

Concrete

Characteristics

Composite material. High-performance concrete infused with organic fibers, providing resistance to compression and bending.

Benefits

Durable and robust. Suitable for molding various pieces.

Applications

We use this material for crafting urban furniture components.





AUBRILAM HTE: High outdoor durability

AUBRILAM HTE glued laminated timber (glulam)

With over 45 years of expertise, we have perfected our HTE method for producing glulam specifically designed for outdoor use, serving as lighting pole supports or structural elements.

- > The process uses ACERBOIS GLULAM-certified glued laminated beams.
- > The glulam planks from these beams are sized based on the height of the pole, its cross-section (round or square) and the required load capacity. These planks are made of small-section lamellas joined together with adhesive, which minimizes the wood's dimensional and mechanical variations.
- > We choose a naturally rot-resistant wood species from sustainably managed forests, eliminating the need for additional chemical treatment for the intended use conditions.
- > Our chosen adhesive is designed to withstand outdoor conditions, even with significant humidity and temperature fluctuations.
- > The stain we use, along with our application method, ensures durability for up to 7 years.

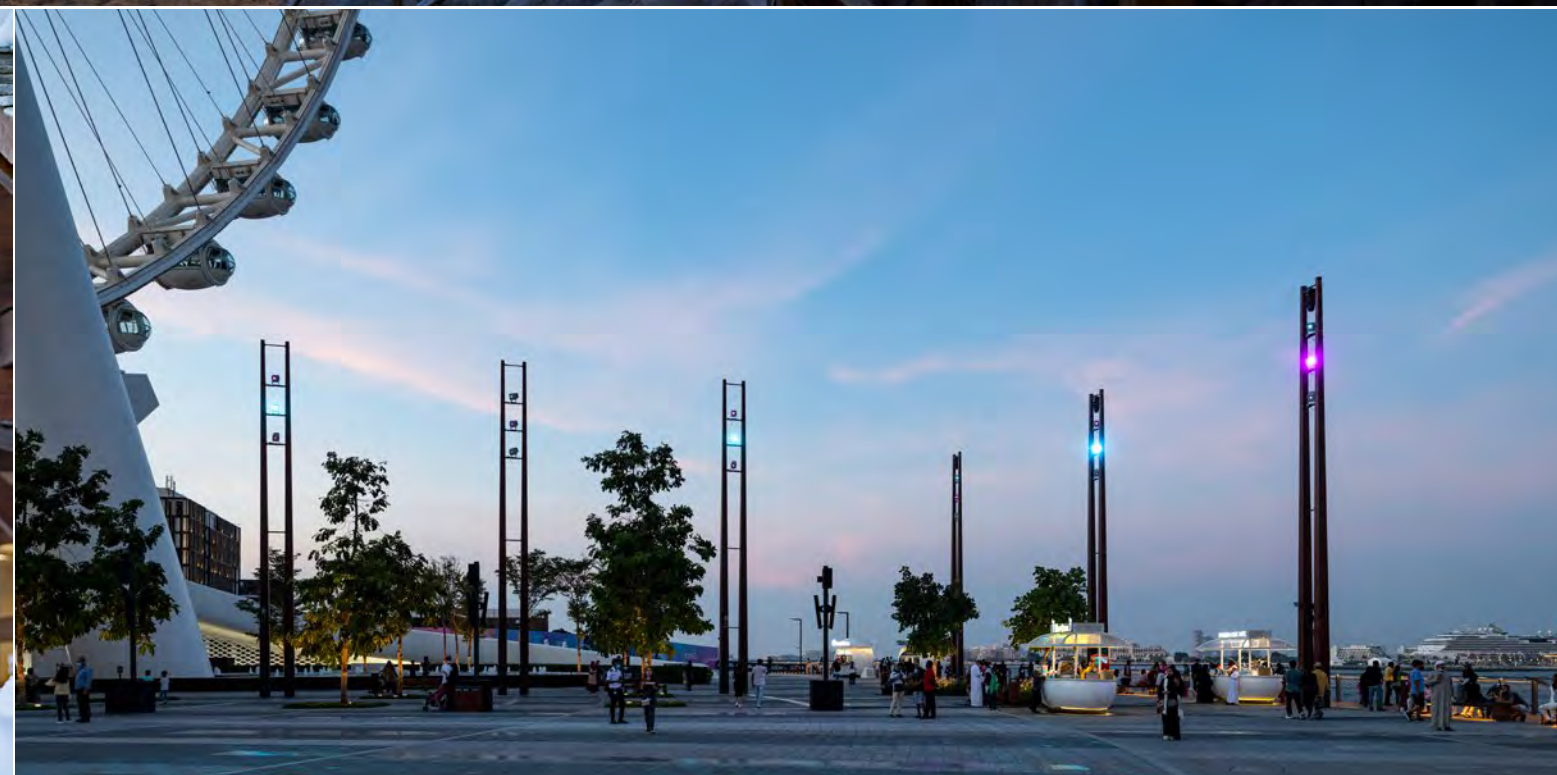

Glulam is a well-engineered material. Its exceptional mechanical strength makes it perfect for structures over 10 meters tall, allowing for large spans without adding unnecessary weight. Furthermore, the manufacturing process produces very little waste, ensuring efficient use of resources.

Our process

Our manufacturing process

Our products are crafted and assembled in our own workshops. The exceptional quality of our products stems from a finely-tuned industrial process combined with precise manual craftsmanship.



1 Material reception

When the glulam beams arrive at our workshop, they are allowed to acclimate, ensuring the wood is in the best condition for processing.

2 Cutting, planing and sizing

These steps involve cutting the beams and boards to the exact dimensions needed, ensuring precise calibration and minimizing material waste.



3 Gluing

The adhesive is applied in a controlled, uniform manner. After gluing, the pole is placed on a clamping bench for 8 to 10 hours. Each gluing session involves taking samples for shear tests to verify pole strength. These tests are crucial for CE marking compliance.

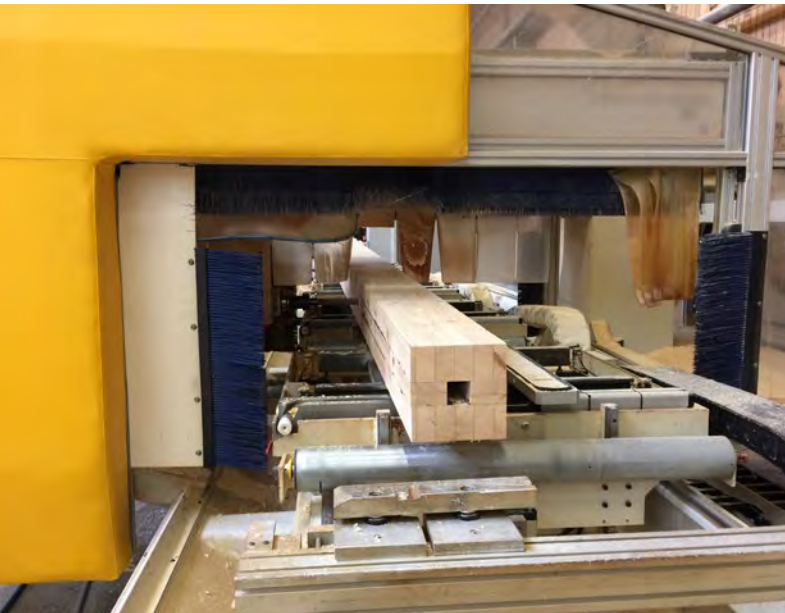

4 Machining and turning

Our precision CNC machines handle the material with accuracy to achieve our final product: cutting to length, partial surfacing, shoulder shaping, drilling and turning.



5 Surface preparation

Filling, touch-ups and sanding: These manual processes smooth and even out the wood's surface in preparation for staining.

The scraping technique is a unique finish that highlights the wood grain. Mechanical brushes remove the softer parts, revealing the natural texture and enhancing the aesthetic without affecting the structural strength.



6 Staining

Staining is done in multiple layers to tint the wood and protect it from UV rays and aging effects. Our stains are solvent-free and applied evenly with a spray gun. The process and thicknesses are continuously monitored to ensure the durability of the stain according to our quality commitments.

Liming is a more advanced technique that achieves an aged effect on the wood.

7 Assembly

Once assembled, each product undergoes inspection, and a CE conformity label ensures its traceability.



8 Packaging

Our products are carefully packaged, with the packaging method tailored in advance based on the transportation type and installation site.

For large poles like the 16-meter ones, our teams conduct a specialized lifting study.

Wood maintenance

Maintenance preserves the aesthetic appeal of our products. Like all outdoor installations, our products endure various weather conditions and environmental factors, as well as potential misuse. We are committed to providing durable products designed for easy maintenance from the outset.

Sustainability involves maintaining the quality and functionality of our investments, which necessitates regular upkeep. After years of research and testing, we have developed a process using high-performance water-based stains, ensuring a lifespan of 6 to 15 years depending on the wood type and exposure conditions.

Our stains offer a variety of finishes to seamlessly blend with the surroundings while shielding the wood from external elements such as UV rays, weathering and pests. To uphold the integrity, beauty, and functionality of our products, regular maintenance is essential.

We suggest maintaining Scots Pine products (poles) every 6 to 8 years and Accoya products (bollards and urban furniture) every 10 to 15 years, depending on their exposure and use. Maintenance intervals may vary based on site conditions and product usage.

We have developed two maintenance protocols:

- Routine maintenance: performed at recommended intervals;
- Restoration maintenance: for repairing damaged components.

Aligned with our sustainable practices, our urban furniture is designed for easy component replacement when necessary.



We provide a comprehensive maintenance package, including maintenance products that adhere to our manufacturing processes, technical implementation manuals, and training for qualified technicians to work on all installation sites.

Our AUBRILAMCare service is available to assist you with maintaining your equipment, making maintenance of our products accessible everywhere.

Contact us at aubrilamcare@aubrilam.fr or call us on +33 473 318 686.

Design compliant with standards

CE marking

From the raw material, wood, to installation on-site, we oversee every step of the manufacturing process. All our poles, ranging from 3 to 16 meters in height, produced in our factory, meet stringent European requirements and directives.

They bear the CE marking, ensuring a meticulously controlled manufacturing process. This marking guarantees safety to our customers.

The design of these products must meet the performance standards specified in the European Technical Assessment (ETA) issued by the Centre Scientifique et Technique du Bâtiment (CSTB). A Declaration of Performance sheet is available for each CE-marked product, outlining its specifications. The provisions in the ETA are based on a structural lifespan of the poles of 25 years.

To ensure consistent performance, we conduct factory production checks and tests on samples as prescribed by the ETA.

For this purpose, we have implemented daily production control.

The checks cover various aspects of the product:

- base, pole and section dimensions;
- properties of raw materials: glulam and metal components;
- mechanical resistance to wind loads;
- moisture content of glulam planks;
- shear strength of the adhesive joint.



Shear testing

For every gluing batch, we extract six samples: three are tested while the other three are archived for three years. These tests confirm the adhesive joint's shear strength.

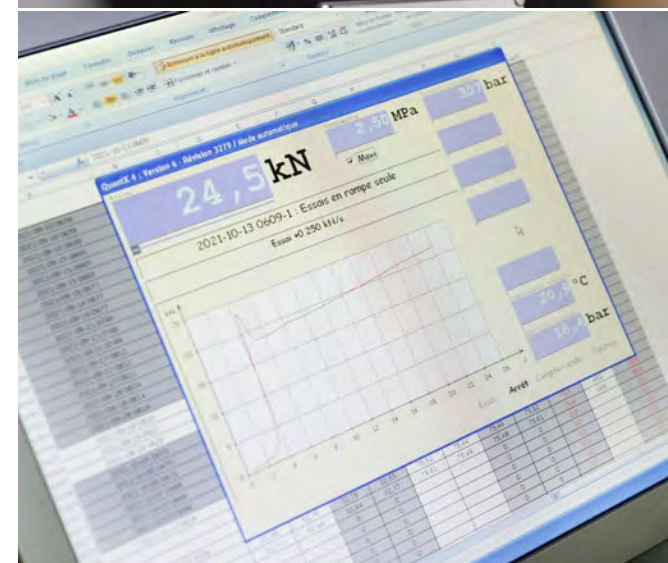

Traceability

Each component delivered to our factory is assigned a batch number. We then re-code the semi-finished and finished parts during their processing. This system, implemented by our quality department, ensures complete traceability of our production.

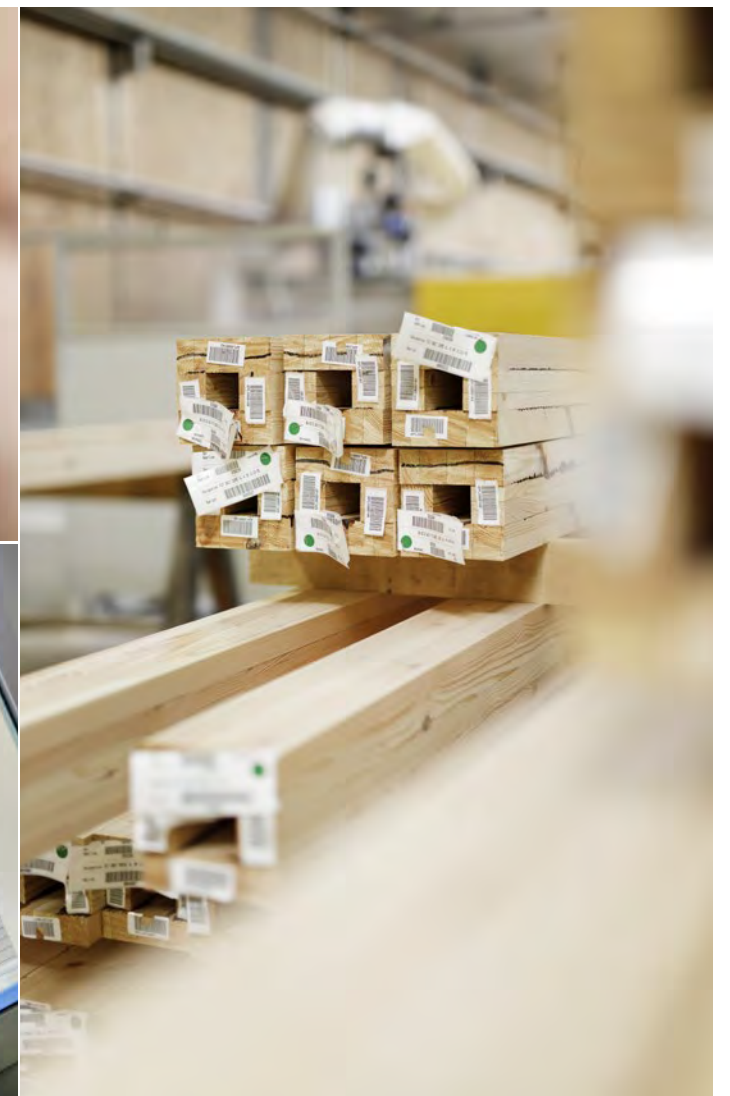

Customized products

The products we manufacture and showcase in this catalog are designed to furnish outdoor spaces and meet the diverse needs of landscaping projects, regardless of their nature.

We believe that the furniture selected to complement a site should mirror its identity, particularly when maintaining visual harmony is key. Conversely, furniture should also enhance the site, making it distinctive through its uniqueness and aesthetic appeal.

To address these needs, we have developed customization solutions and a range of adaptable accessories for our standard products. Our manufacturing methods and choice of materials provide ample opportunities for diverse finishes and adjustments.

Our designers regularly create new patterns and color combinations to offer fresh customization ideas.

You can choose specific shades or finishes, and opt to have logos or text engraved on our products. We also provide decorative patterns through wood engraving or by integrating additional components onto existing structures.

Moreover, we offer various signage options like plaques and banner supports, along with innovative features such as phosphorescent resin systems. Our range includes accessories that offer additional practical features, such as USB ports or wireless charging systems.

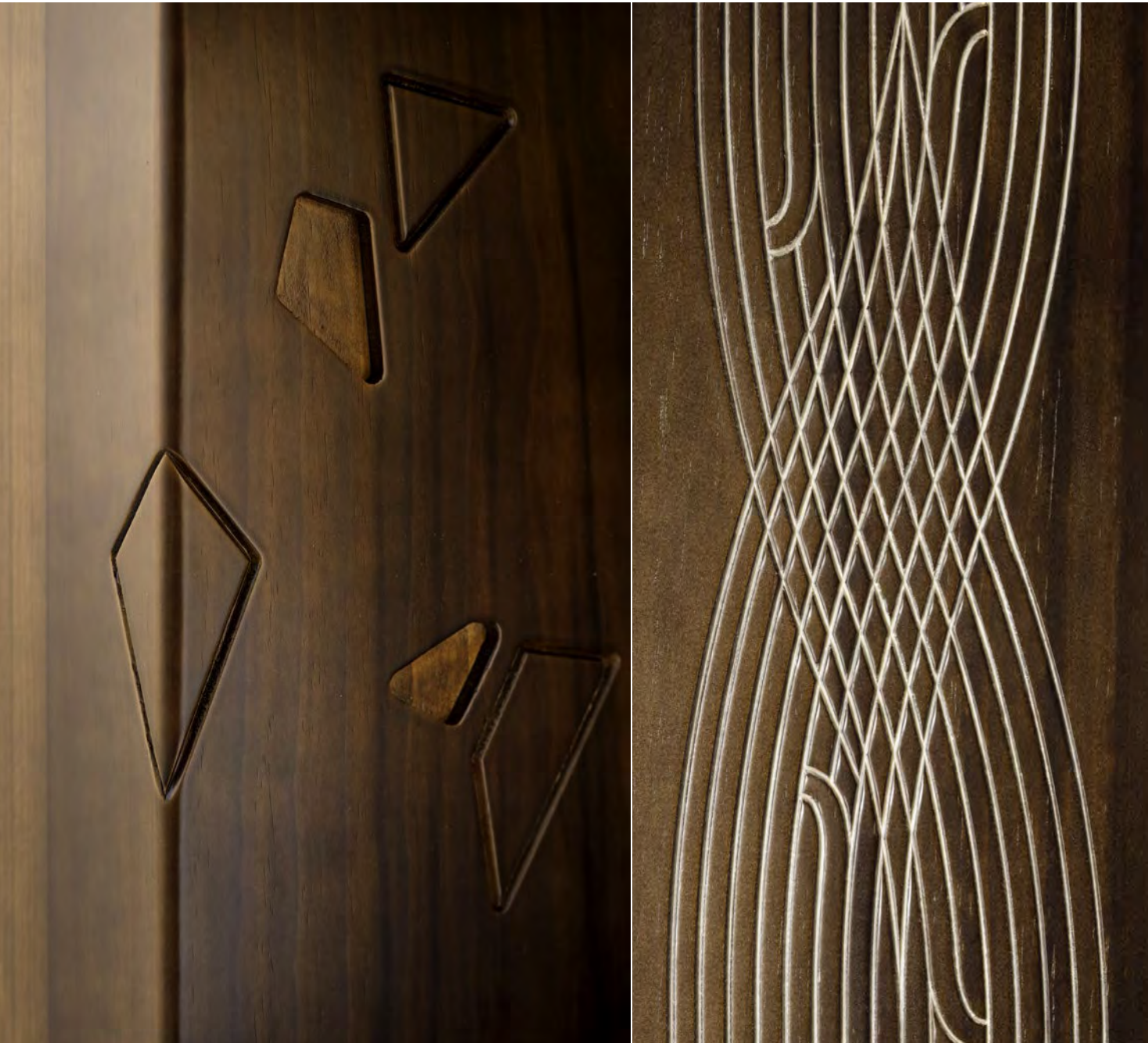



Customization

Wood offers limitless possibilities

Our process for glulam structures is perfectly suited for designing tall products. Its structural qualities optimize product weight, making transportation and on-site installation easier.

Wood also simplifies the creation of customized mounting systems for each project. This can include mounting new luminaires, supporting a series of spotlights with a grid, or using cables for hanging string lights or shade sails.

Additionally, wood provides aesthetic advantages. It can be machined and shaped to achieve specific forms, and the variety of color and finish options offers numerous possibilities.

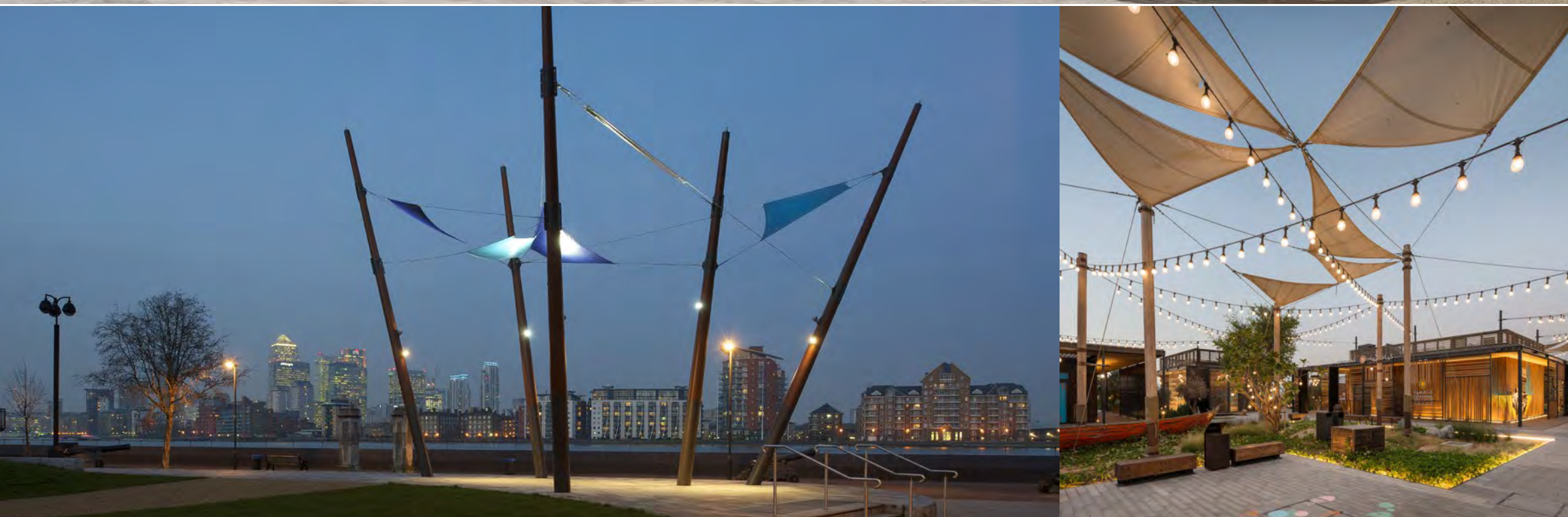

The right solution for every project

Our design office handles the specific structural calculations, designs the entire product and its mounting system. We provide expertise at every stage of product development to meet project requirements. Our designers contribute to designing specific parts and decorative motifs, and they collaborate on color schemes for the project.

We coordinate closely with our factory for prototype production and oversee manufacturing. Our workshop is equipped to handle large components, and our technicians design custom packaging and crates for each transport configuration.

With these capabilities in-house, we offer end-to-end support — from initial design to manufacturing — ensuring your project receives comprehensive, tailored solutions.

Support for planning

A range of optimized tools and services

Our offerings cater to all types of developments — public or private, urban or rural, large-scale or small. We understand the importance of making the right choices during the design phase.

To assist our clients in selecting the best furniture for their needs, we provide a range of resources and services. Each product in our catalog is described in detail, including materials, dimensions, weight, functionalities, photometric data, and accessories.

We offer technical feasibility studies, perform calculations and sizing tailored to the installation site, and provide photometric analyses and layout plans.



An eco-friendly approach tailored to your project

When evaluating a project, we assess the ecological impact of all selected products and provide an environmental report based on ten criteria: carbon footprint, hazardous waste, energy consumption, resource depletion, air toxicity, water toxicity, water consumption, photochemical ozone creation, air acidification, and water eutrophication.

15.
Lighting project.
Environmental impact comparison.
You benefit from an experience and aesthetic solution to save with.

Ecological potential
10 environmental indicators compared.

PROJECT
Gardaland - Netherlands
• 150 8-meter Dome XL 504 mm lighting columns.
• 10 5-meter Dome XL 100 mm lighting columns.
• 2 2.5-meter Dome XL 100 mm lighting columns.
• 10 5-meter Dome XL 100 mm lighting columns.

Ecological potential
10 environmental indicators compared.

PROJECT
Gardaland - Netherlands
• 150 8-meter Dome XL 504 mm lighting columns.
• 10 5-meter Dome XL 100 mm lighting columns.
• 2 2.5-meter Dome XL 100 mm lighting columns.
• 10 5-meter Dome XL 100 mm lighting columns.

The gains

22.225 kg
of CO₂ offset

52.431 kWh
saved (from renewable energy)

-1.645 kg
of hazardous waste

AUBRILAM

The color chart

To complement our product collections, we offer a range of shades and finishes developed for the materials we use: wood, metal, and compact laminate. Each material has unique properties that reveal colors and textures in different ways. Wood can be finished smoothly or with a brushed effect, and its appearance transforms when combined with metal.

Our special whitewash finishes, created through a proprietary process, give wood an aged look. This natural material, with its distinctive grain patterns, adds unique character to each of our products.

Metal, often used as a structural element, seamlessly integrates with the ground or accessories. We select a "sanded" finish suitable for outdoor use, creating a striking contrast with wood through a play of textures and colors.

Our compact laminate pieces feature expansive surfaces that are perfect for applying designs curated by our designers. Developed by our suppliers for seamless integration into new projects, these designs blend beautifully with the wood and metal tones in our color chart.

All the shades and finishes we offer have been rigorously tested at AUBRILAM. They are chosen to provide a wide range of options while ensuring harmonious, warm, and timeless combinations.

Our color chart includes:

- 5 smooth wood tones, 7 brushed wood tones, and 4 whitewash wood tones;
- 6 classic metal shades and 2 expressive metal shades;
- 5 compact laminate designs.



Wood
W01 Brume | **W02** Cooper | **W03** Tyrol Pine
W04 Chestnut | **W05** Ferrara Oak
W06 Basalt | **W07** Meteor | **W08** Origin
W09 Alizé | **W10** La Mer | **W11** Burnt Umber

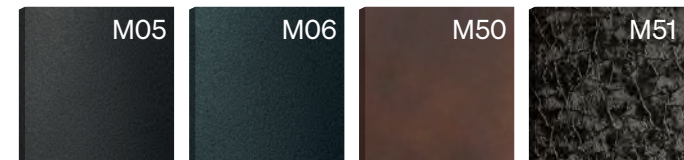

Metal
M01 Graphite | **M02** Silver | **M03** RAL 7006 matt fine texture
M04 Grey 2900 sanded | **M05** Black 2100 sanded
M06 Black 2200 sanded **M50** Random rust | **M51** Crystal black

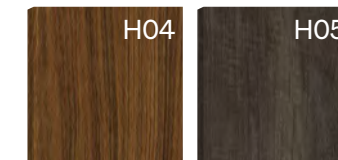
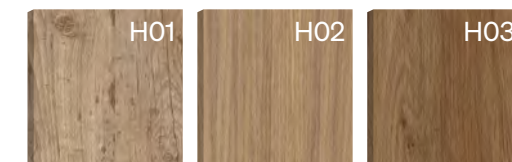

Compact laminate
H01 Fir Platinum | **H02** Enigma | **H03** Voyager
H04 Taurus | **H05** Smoked Marvel Walnut

Wood finishes Smooth

These shades are carefully crafted to achieve a silky-smooth texture. Both authentic and modern, they add warmth to any space. Their bright and rich qualities truly shine in outdoor environments.



Brume



Cooper



Tyrol Pine



Chestnut



Ferrara Oak

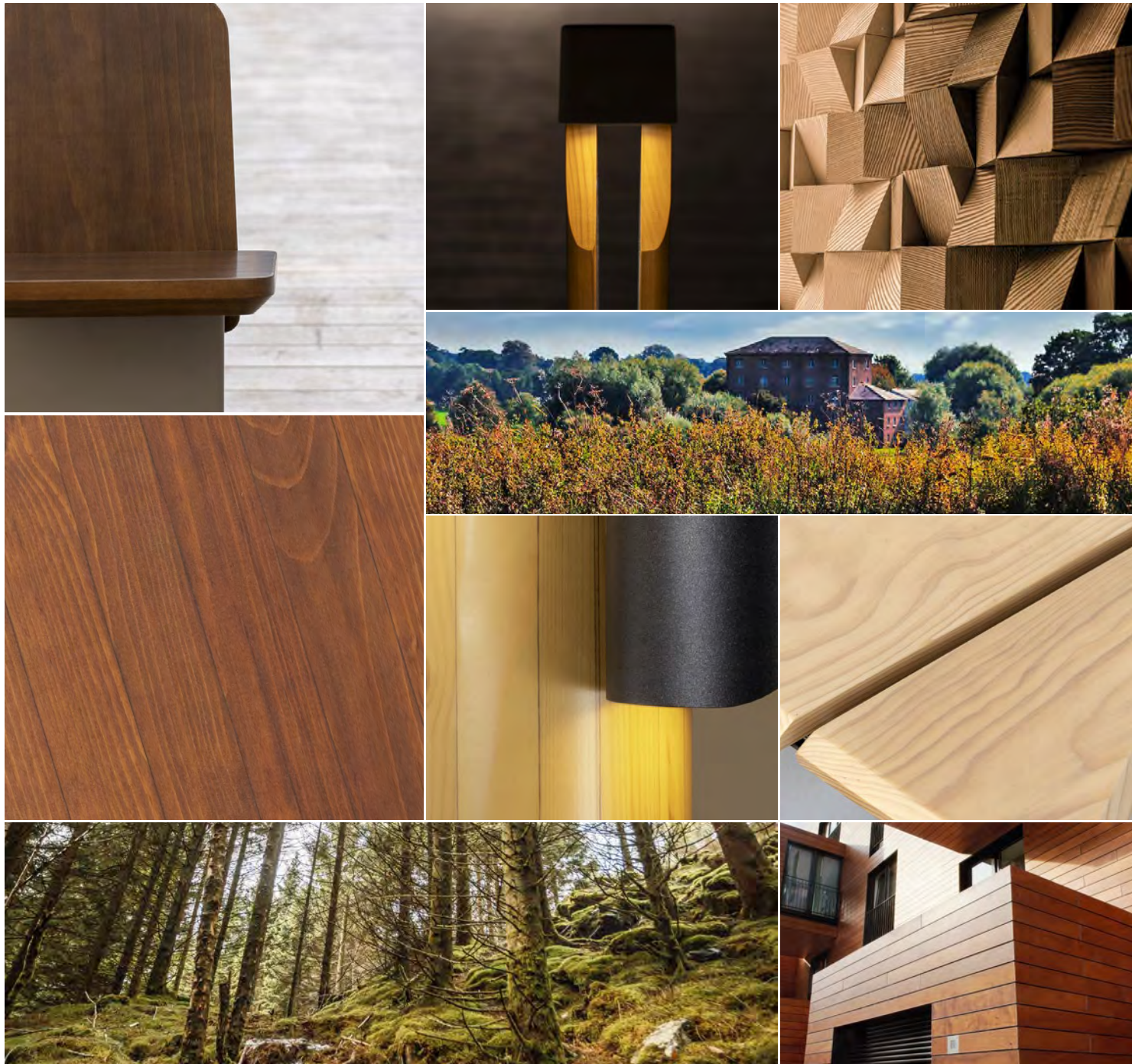

Wood finishes

Brushed

These shades are applied to textured surfaces that mimic the look of aged wood, weathered by wind, water, or heat. The raised patterns give these finishes a distinct charm, capturing and reflecting light in outdoor environments.



Basalt

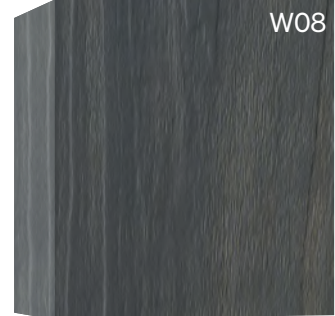

Origin



Brume



Cooper



Tyrol Pine

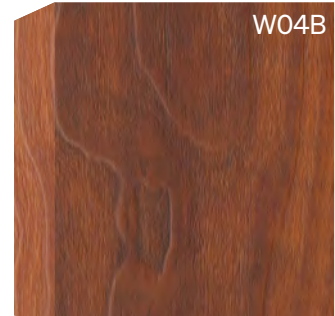

Chestnut



Ferrara Oak

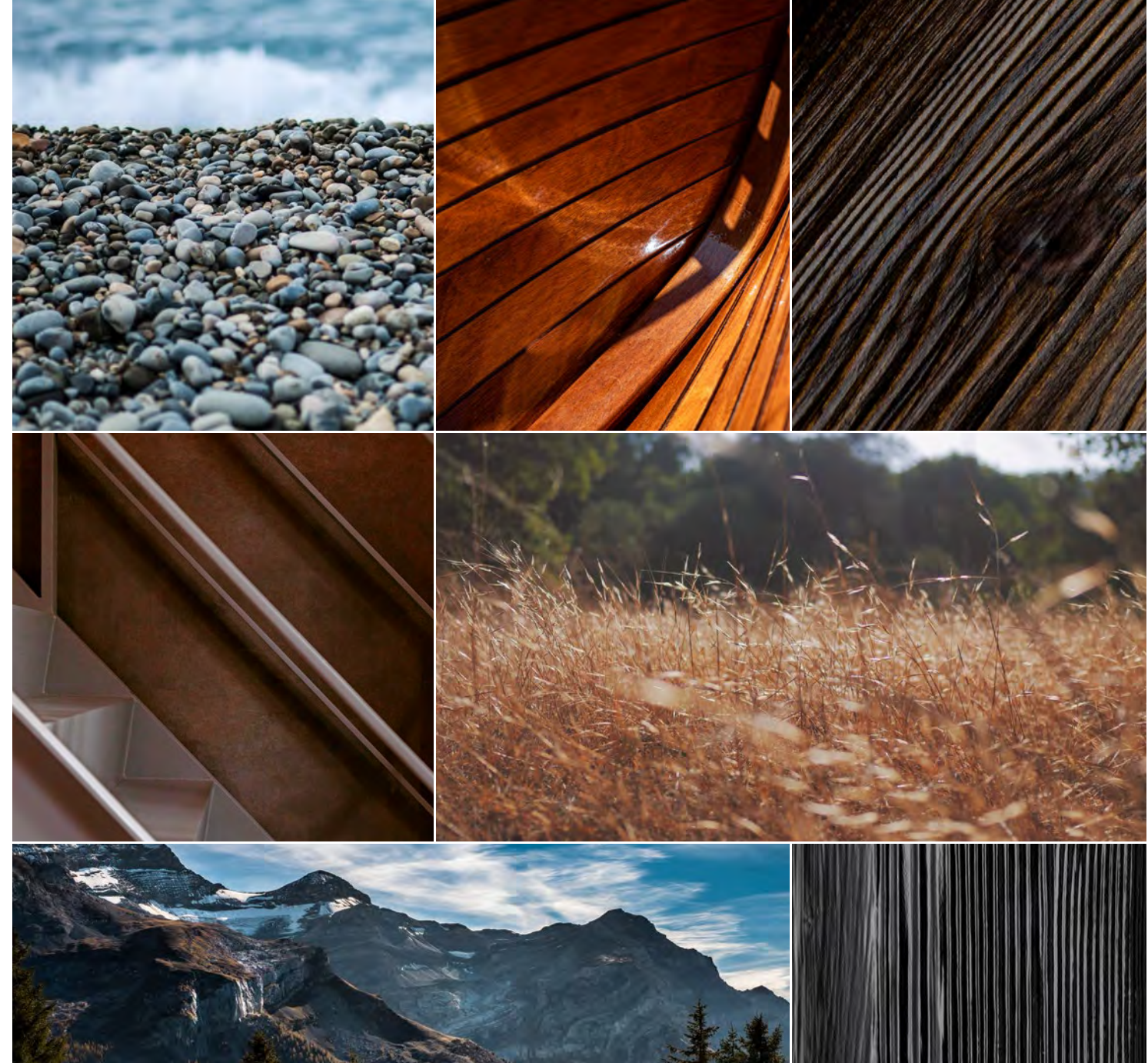

Metal finishes

Classic

These shades are designed for outdoor settings, accentuating the architectural identity while complementing the wood elements. The selection features a light shade and a variety of darker hues with both warm and cool tones.



Graphite



Silver



RAL 7006 matt fine texture



Grey 2900 sanded

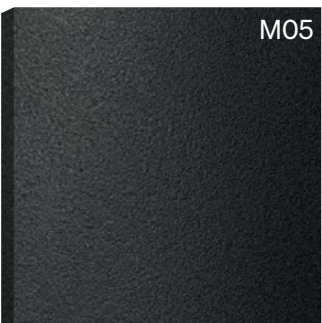

Black 2100 sanded



Black 2200 sanded

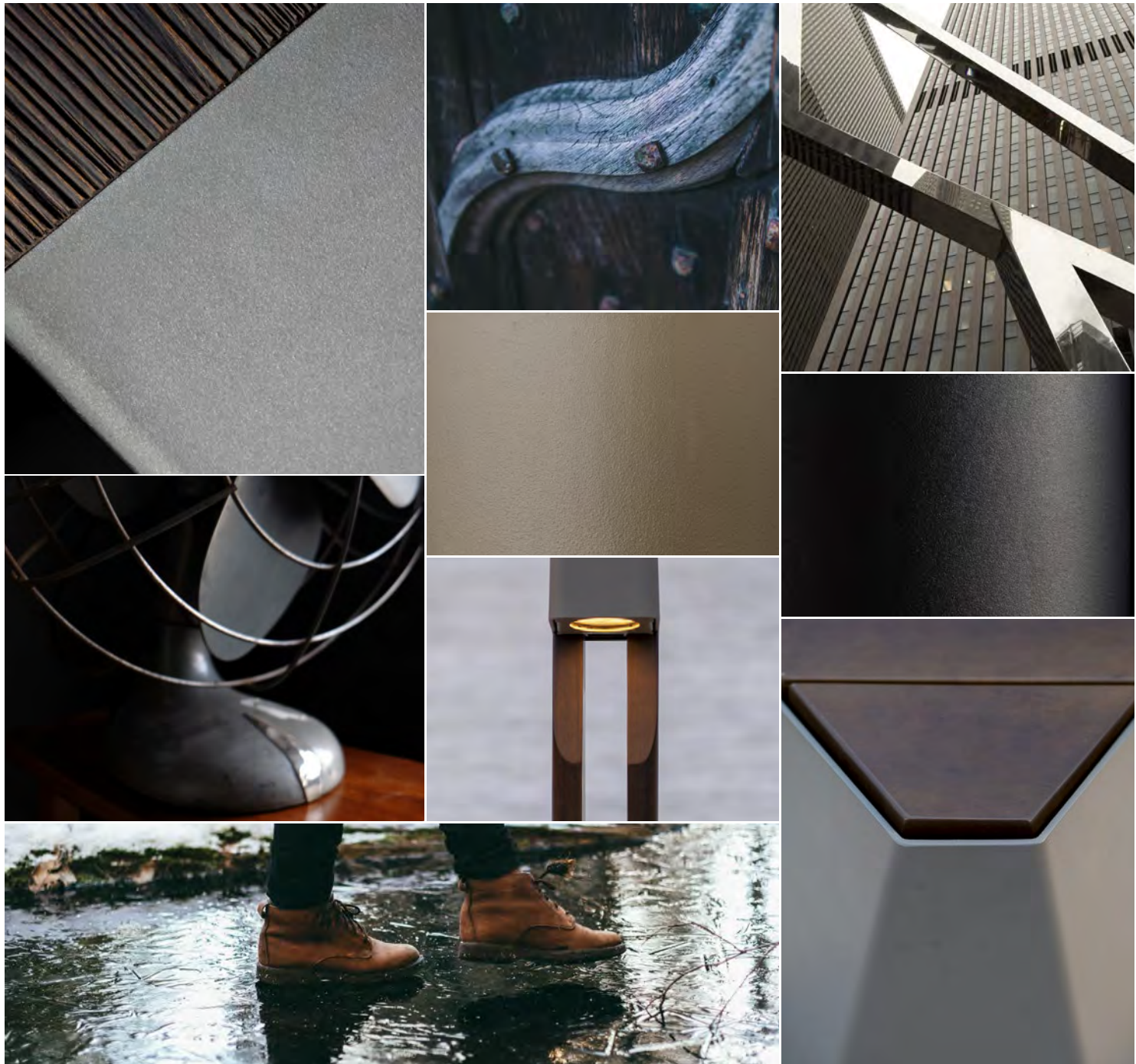

Metal finishes
Expressive

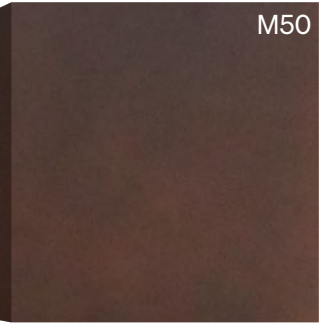

Random rust

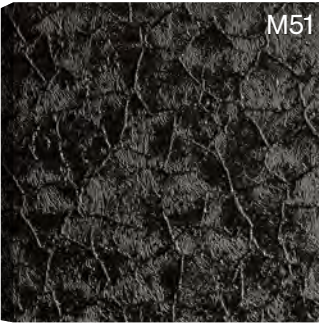

Crystal black

These two shades are distinctive due to their finishes, showcasing the transformation of the material: metal that rusts or cracks. When combined with wood, they enhance the unique ambiance of a site or accentuate its character.

High-pressure compact laminate designs

These styles, designed for our furniture pieces, perfectly complement several of our wood tones, ensuring harmony across our collections. They evoke aged, natural, or darker wood tones, adding warmth. Our latest design, almost black, mimics the appearance of "charred wood" found in certain designs.



Fir Platinum

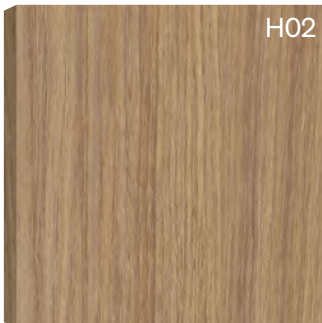

Enigma

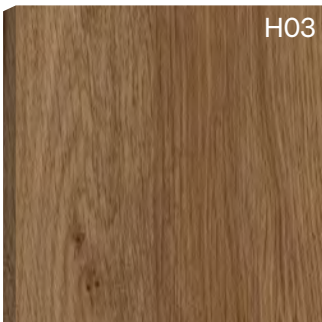

Voyager

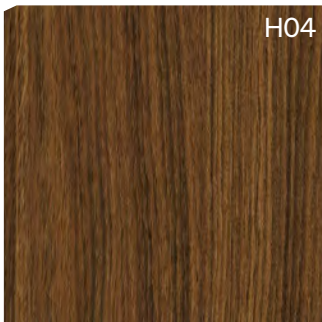

Taurus

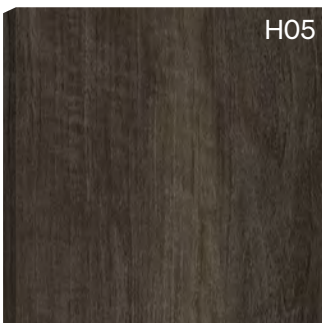

Smoked Marvel Walnut

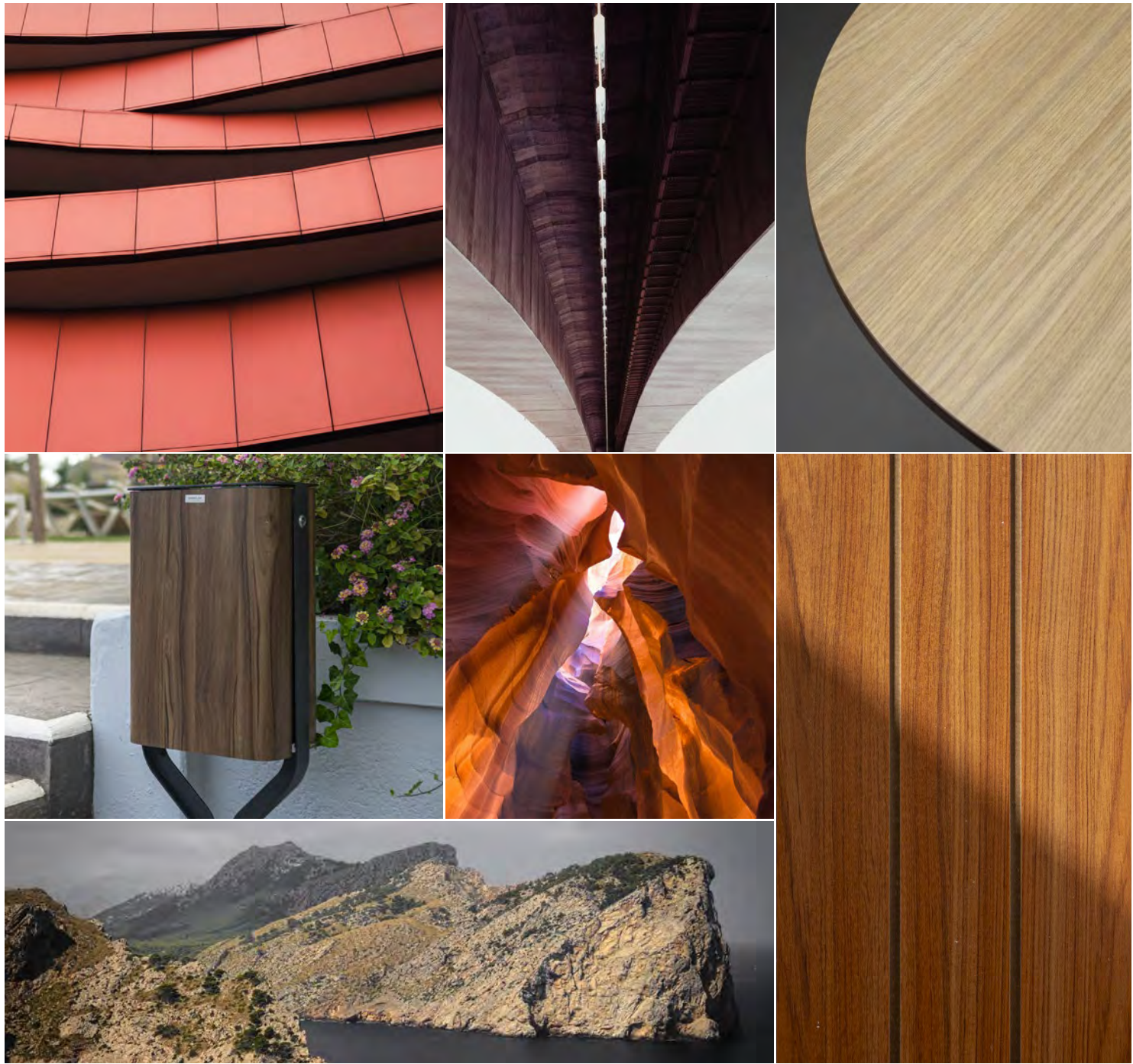

Product offering

AUBRILAM offers lighting and urban furniture solutions that enhance the beauty, comfort, and sustainability of living spaces. Year after year, we strive to develop new ranges while consistently improving product quality.

Our product catalog is organized into four main categories: furniture, lighting points, poles, and shelters and shades

Furniture

Our products cater to urban environments for relaxation and leisure: chairs, benches, litter bins, planters, barriers, bike racks, and bollards.



Lighting points

Lighting solutions including bollards and light building elements for illuminating and marking outdoor spaces such as walkways, squares, building surroundings, riverbanks, and bike paths.

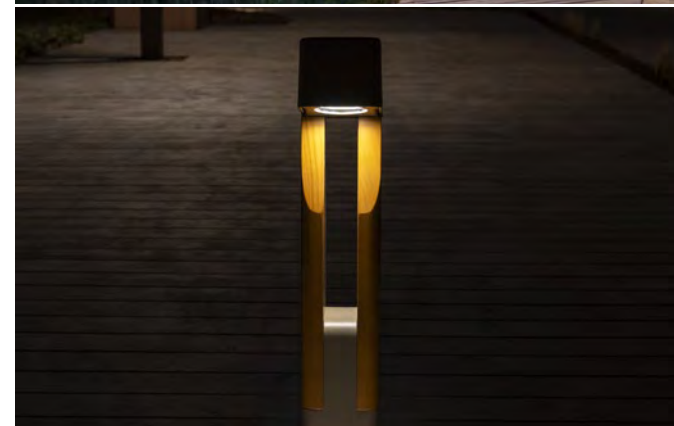

Poles

Our range includes poles designed to support outdoor lighting equipment. Available in round or square sections, they range from 3.50 meters to 16 meters in height.



Shelters and shades

We offer structures designed to shelter cars, bicycles, or users from inclement weather or sunlight.





Use
 Public squares, pathways, parks, or relaxation areas.

Materials
 Aluminum structure with polyester powder coating. Seat made of solid Accoya® acetylated wood, sourced from sustainably managed forests. Four-coat stain finish. Stain durability > 10 years. Salt air protective coating available upon request.

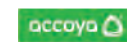

Finish
 The finish shown is in Brume wood and Black 2100 sanded metal, code +.W01.M05. Finish options available in any of the standard shades from the AUBRILAM color chart. Please refer to page 35 of the catalog. Other colors available upon request.

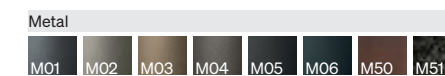
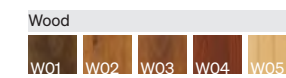

FNO0001 Stool
 600 × 450 mm • H 460 mm



Use
 Public squares, pathways, parks, or relaxation areas.

Materials
 Stainless steel structure with polyester powder coating. Seat and backrest made of solid Accoya® acetylated wood, sourced from sustainably managed forests. Four-coat stain finish. Stain durability > 10 years. Salt air protective coating available upon request.

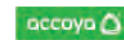

Accessories
 Armrests available upon request.

Finish
 The finish shown is in Brume wood and Black 2100 sanded metal, code +.W01.M05. Finish options available in any of the standard shades from the AUBRILAM color chart. Please refer to page 35 of the catalog. Other colors available upon request.

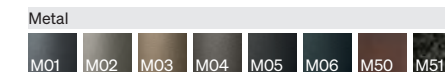
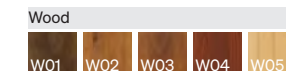

FSK0001 Stool
 467 × 357 mm • H 449 mm
FSK0002 Stool with backrest
 367 × 397 mm • H 709 mm



Use
 Public squares, pathways, parks, or relaxation areas.

Materials
 Aluminum structure with polyester powder coating. Seat and backrest made of solid Accoya® acetylated wood, sourced from sustainably managed forests. Four-coat stain finish. Stain durability > 10 years. Salt air protective coating available upon request.

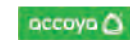

Accessories
 Armrests available upon request.

Finish
 The finish shown is in Brume wood and Black 2100 sanded metal, code +.W01.M05. Finish options available in any of the standard shades from the AUBRILAM color chart. Please refer to page 35 of the catalog. Other colors available upon request.

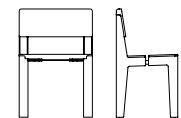
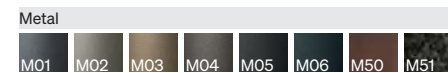
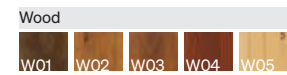

FSK0003 Chair
 500 × 420 mm • H 740 mm





Use
 Public squares, pathways, parks, or relaxation areas.

Materials
 Aluminum structure with polyester powder coating. Seat and backrest made of solid Accoya® acetylated wood, sourced from sustainably managed forests. Four-coat stain finish. Stain durability > 10 years. Salt air protective coating available upon request.

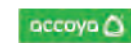

Finish
 The finish shown is in Brume wood and Black 2100 sanded metal, code +W01.M05. Finish options available in any of the standard shades from the AUBRILAM color chart. Please refer to page 35 of the catalog. Other colors available upon request.

Wood							
W01	W02	W03	W04	W05	W06	W07	W08
W09	W10	W11					
Metal							
M01	M02	M03	M04	M05	M06	M50	M51

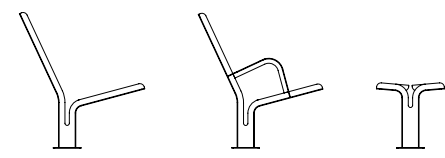

FUT0005 Chair
 857 × 514 mm • H 928 mm
FUT0006 Chair with armrests
 857 × 574 mm • H 928 mm
FUT0007 Footrest
 1,571 × 514 mm • H 928 mm



Use
 Areas for relaxation, rest, and leisure.

Materials
 Electrogalvanized steel structure with polyester powder coating. Seat and backrest made of solid Accoya® acetylated wood, sourced from sustainably managed forests. Four-coat stain finish. Stain durability > 10 years. Insert made of high-performance concrete and protected by a BF 24H type sealer. Salt air protective coating available upon request.



Finish
 The finish shown is in Brume wood and Black 2100 sanded metal, code +.W01.M05. Finish options available in any of the standard shades from the AUBRILAM color chart. Please refer to page 35 of the catalog. Other colors available upon request.

Wood										
W01	W02	W03	W04	W05	W06	W07	W08	W09	W10	W11
Metal										
M01	M02	M03	M04	M05	M06	M50	M51			

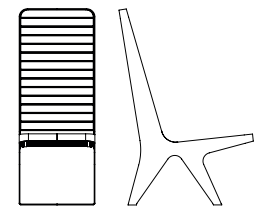

FRV0001 Chair
 450 x 800 mm • H 1,166 mm



Use
 Areas for relaxation, rest, and leisure.

Materials
 Electrogalvanized steel structure with polyester powder coating. Seat and backrest made of solid Accoya® acetylated wood, sourced from sustainably managed forests. Four-coat stain finish. Stain durability > 10 years.
 Low seat and insert made of high-performance concrete and protected by a BF 24H type sealer. Salt air protective coating available upon request.



Finish
 The finish shown is in Brume wood and Black 2100 sanded metal, code +.W01.M05. Finish options available in any of the standard shades from the AUBRILAM color chart. Please refer to page 35 of the catalog. Other colors available upon request.

Wood										
W01	W02	W03	W04	W05	W06	W07	W08	W09	W10	W11

Metal										
M01	M02	M03	M04	M05	M06	M50	M51			

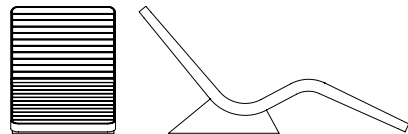

FRV0002 Lounger
 1,675 x 660 mm • H 800 mm



Use

Areas for relaxation, rest, and leisure.

Materials

Electrogalvanized steel structure with polyester powder coating. Cladding in solid Accoya® acetylated wood, sourced from sustainably managed forests. Four-coat stain finish. Stain durability > 10 years. Seats and armrests made of high-performance concrete and protected by a BF 24H type sealer. Salt air protective coating available upon request.

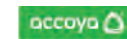

Technology

Option to integrate a standard charging module:
- Up to a maximum of 4 charging points;
- Each with USB 2 type A - 5V - 1A - 5W;
- Mounting in a metal housing.

FRV0004



FRV0005



FRV0006



FRV0007



FRV0008



FRV0009



FRV0010



Finish

The finish shown is in Brume wood and Black 2100 sanded metal, code +W01.M05. Finish options available in any of the standard shades from the AUBRILAM color chart. Please refer to page 35 of the catalog. Other colors available upon request.

Wood

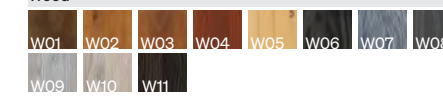

Metal

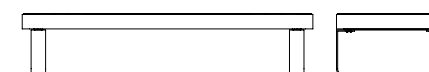

Structure
2,010 x 750 mm • H 430 mm



Use
 Areas for relaxation, rest, and leisure.

Materials
 Electro galvanized steel structure with polyester powder coating. Seat and backrest made of solid Accoya® acetylated wood, sourced from sustainably managed forests. Four-coat stain finish. Stain durability > 10 years. Salt air protective coating available upon request.

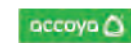

Technology
 Option to integrate a standard charging module:
 - Up to a maximum of 4 charging points;
 - Each with USB 2 type A - 5V - 1A - 5W;
 - Mounting in a metal housing.

Finish
 The finish shown is in Brume wood and Black 2100 sanded metal, code +W01.M05. Finish options available in any of the standard shades from the AUBRILAM color chart. Please refer to page 35 of the catalog. Other colors available upon request.

Wood							
W01	W02	W03	W04	W05	W06	W07	W08
W09	W10	W11					

Metal							
M01	M02	M03	M04	M05	M06	M50	M51

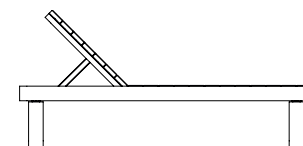

FRV0003 Sunlounger
 2,010 x 750 mm • H 945 mm



Use
 Areas for relaxation, rest, and leisure.

Materials
 Electrogalvanized steel structure with polyester powder coating. Seat made of solid Accoya® acetylated wood, sourced from sustainably managed forests. Four-coat stain finish. Stain durability > 10 years. Salt air protective coating available upon request.

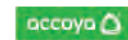

Technology
 Option to integrate a standard charging module:
 - Up to a maximum of 4 charging points;
 - Each with USB 2 type A - 5V - 1A - 5W;
 - Mounting in a metal housing.

Finish
 The finish shown is in Brume wood and Black 2100 sanded metal, code +W01.M05. Finish options available in any of the standard shades from the AUBRILAM color chart. Please refer to page 35 of the catalog. Other colors available upon request.

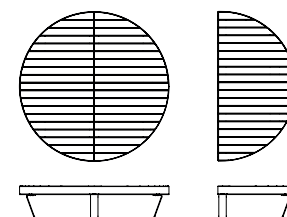
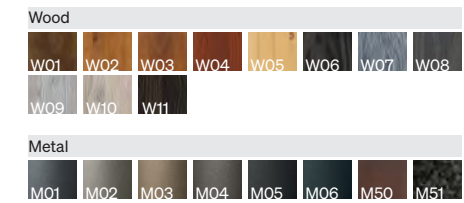

FRV001 Round bench
 Ø 2 m • H 430 mm
FRV002 Half-round bench
 2 x 1 m • H 430 mm



Use
 Public squares, pathways, parks, or relaxation areas.

Materials
 Electrogalvanized steel structure with polyester powder coating. Seat made of solid Accoya® acetylated wood, sourced from sustainably managed forests. Four-coat stain finish. Stain durability > 10 years. Salt air protective coating available upon request.



Accessories
 Armrests available upon request.

Finish
 The finish shown is in Brume wood and Black 2100 sanded metal, code +.W01.M05. Finish options available in any of the standard shades from the AUBRILAM color chart. Please refer to page 35 of the catalog. Other colors available upon request.

Wood							
W01	W02	W03	W04	W05	W06	W07	W08
W09	W10	W11					

Metal							
M01	M02	M03	M04	M05	M06	M50	M51



FUT0001 3-seater bench
 1,864 x 468 mm • H 450 mm



Use
 Public squares, pathways, parks, or relaxation areas.

Materials
 Electrogalvanized steel structure with polyester powder coating. Seat and backrest made of solid Accoya® acetylated wood, sourced from sustainably managed forests. Four-coat stain finish. Stain durability > 10 years. Salt air protective coating available upon request.



Accessories
 Armrests available upon request.

Finish
 The finish shown is in Brume wood and Black 2100 sanded metal, code +.W01.M05. Finish options available in any of the standard shades from the AUBRILAM color chart. Please refer to page 35 of the catalog. Other colors available upon request.

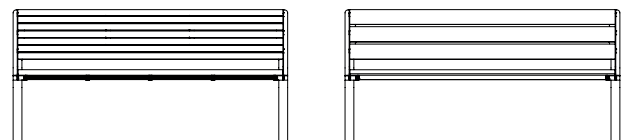
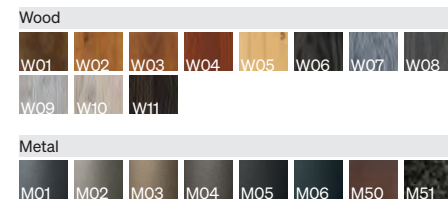

FUT0002 3-seater bench with 14 slats
 1,864 × 579 mm • H 900 mm
FUT0003 3-seater bench with 6 slats
 1,864 × 579 mm • H 450 mm



Use
 Public squares, pathways, parks, or relaxation areas.

Materials
 Stainless steel structure with polyester powder coating.
 Seat made of solid Accoya® acetylated wood, sourced from sustainably managed forests. Four-coat stain finish. Stain durability > 10 years. Salt air protective coating available upon request.

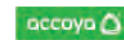

Accessories
 Armrests available upon request.

Finish
 The finish shown is in Brume wood and Black 2100 sanded metal, code +W01.M05. Finish options available in any of the standard shades from the AUBRILAM color chart. Please refer to page 35 of the catalog. Other colors available upon request.

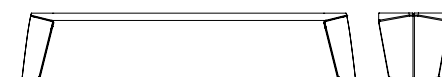
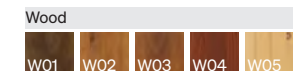

FN00002 Bench
 2,282 x 480 mm • H 450 mm

Seating

Notche



Use
Public squares, pathways, parks, or relaxation areas.

Materials
Aluminum structure with polyester powder coating. Seat made of solid Accoya® acetylated wood, sourced from sustainably managed forests. Four-coat stain finish. Stain durability > 10 years. Salt air protective coating available upon request.



Accessories
Armrests available upon request.

Finish
The finish shown is in Brume wood and Black 2100 sanded metal, code +.W01.M05. Finish options available in any of the standard shades from the AUBRILAM color chart. Please refer to page 35 of the catalog. Other colors available upon request.

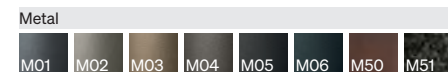
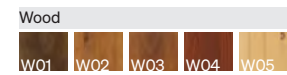

- Stool
- Bench
- 2-seater - 3-seater benches**
- Concrete bench modules
- Litter bin
- Notche 1 lighting bollards
- Notche 2 lighting bollards
- Light building elements - 4 m - 5 m - 6 m

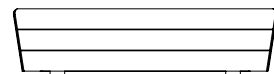
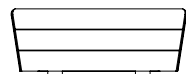

FN00003 2-seater bench
1,200 × 460 mm • H 450 mm
FN00004 3-seater bench
1,800 × 460 mm • H 450 mm



Use
 Public squares, pathways, parks, or relaxation areas.

Materials
 Aluminum structure with polyester powder coating. Seat made of solid Accoya® acetylated wood, sourced from sustainably managed forests. Four-coat stain finish. Stain durability > 10 years. Salt air protective coating available upon request.

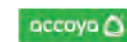

Accessories
 Armrests available upon request.

Finish
 The finish shown is in Brume wood and Black 2100 sanded metal, code +.W01.M05. Finish options available in any of the standard shades from the AUBRILAM color chart. Please refer to page 35 of the catalog. Other colors available upon request.

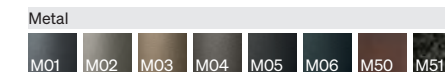
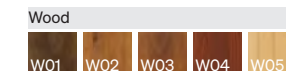

FSK0007 Bench
 3,000 × 574 mm • H 450 mm



Use
 Public squares, pathways, parks, or relaxation areas.

Materials
 Aluminum structure with polyester powder coating. Seat made of solid Accoya® acetylated wood, sourced from sustainably managed forests. Four-coat stain finish. Stain durability > 10 years. Salt air protective coating available upon request.

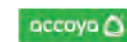

Accessories
 Armrests available upon request.

Finish
 The finish shown is in Brume wood and Black 2100 sanded metal, code +W01.M05. Finish options available in any of the standard shades from the AUBRILAM color chart. Please refer to page 35 of the catalog. Other colors available upon request.

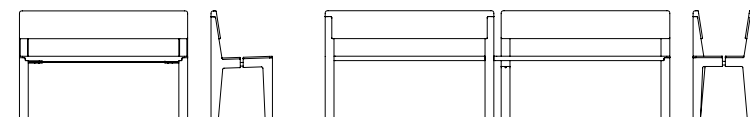
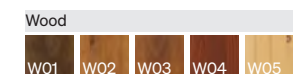

FSK0004 2-seater bench
 1,150 × 420 mm • H 740 mm
FSK0006 Face-to-face bench
 2,350 × 420 mm • H 740 mm

- Stools
- Chair
- Bench
- 2-seater bench
- Face-to-face bench
- Double bench**
- Coffee table
- Litter bin
- Skala lighting bollards
- Light building elements - 3.5 m - 4 m - 5 m
- Poles - 3.5 m to 5 m



Use
Public squares, pathways, parks, or relaxation areas.

Materials
Aluminum structure with polyester powder coating. Seat and backrest made of solid Accoya® acetylated wood, sourced from sustainably managed forests. Four-coat stain finish. Stain durability > 10 years. Salt air protective coating available upon request.



Accessories
Integration of charging points upon request.

Finish
The finish shown is in Brume wood and Black 2100 sanded metal, code +.W01.M05. Finish options available in any of the standard shades from the AUBRILAM color chart. Please refer to page 35 of the catalog. Other colors available upon request.

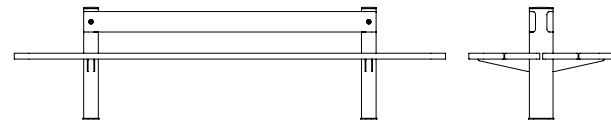
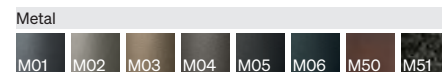
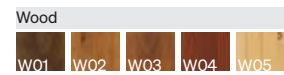

FSK0008 Double bench
2,950 x 990 mm • H 764 mm

Seating

Notche

Concrete bench modules

Stool
Bench
2-seater - 3-seater benches
Concrete bench modules
Litter bin
Notche 1 lighting bollards
Notche 2 lighting bollards
Light building elements - 4 m - 5 m - 6 m



Use
Public squares, pathways, parks, or relaxation areas.

Materials
Stainless steel structure with polyester powder coating.
Seat made of solid Accoya® acetylated wood, sourced from sustainably managed forests. Four-coat stain finish. Stain durability > 10 years. Salt air protective coating available upon request.

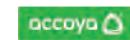

Accessories
Integrated lighting available upon request.

Finish
The finish shown is in Brume wood and Black 2100 sanded metal, code +.W01.M05. Finish options available in any of the standard shades from the AUBRILAM color chart. Please refer to page 35 of the catalog. Other colors available upon request.

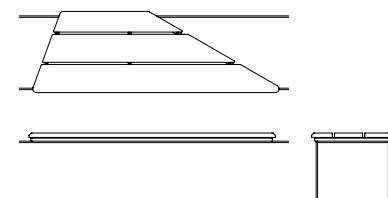
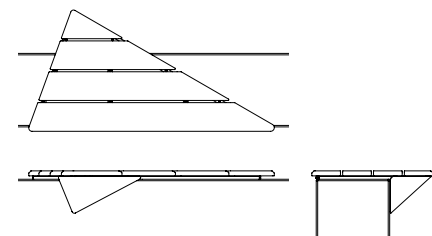
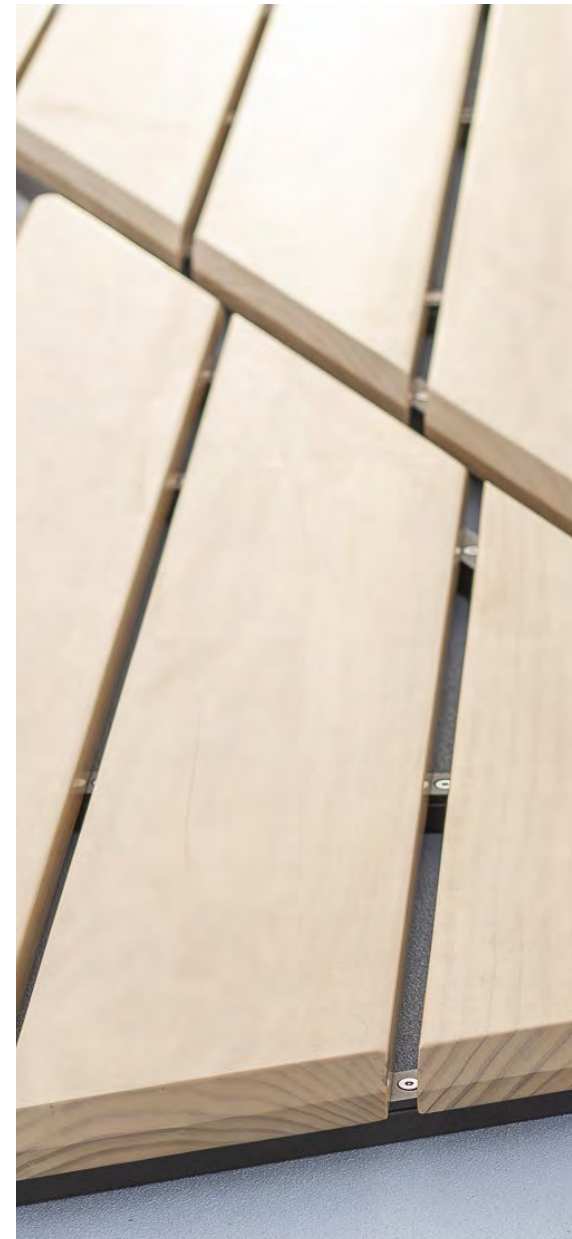
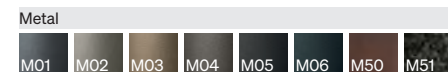
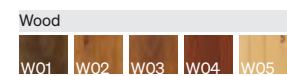

FNO0006 Concrete bench module 1
1.671 × 825 mm • H 288 mm
FNO0007 Concrete bench module 2
1.671 × 550 mm • H 56 mm



Use
 Areas for relaxation, rest, and leisure.

Materials
 Electrogalvanized steel structure with polyester powder coating. Seat and backrest made of solid Accoya® acetylated wood, sourced from sustainably managed forests. Four-coat stain finish. Stain durability > 10 years. Salt air protective coating available upon request.

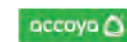

Finish
 The finish shown is in Brume wood and Black 2100 sanded metal, code +.W01.M05. Finish options available in any of the standard shades from the AUBRILAM color chart. Please refer to page 35 of the catalog. Other colors available upon request.

Wood							
W01	W02	W03	W04	W05	W06	W07	W08
W09	W10	W11					

Metal							
M01	M02	M03	M04	M05	M06	M50	M51

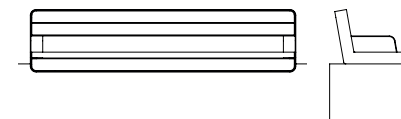

FRV0013 Concrete seating module
 1,800 x 424 mm • H 509 mm



Use

To enhance a reception area, shopping gallery, courtyard, or esplanade.

Materials

Electrogalvanized steel structure with polyester powder coating. Seat made of solid Accoya® acetylated wood, sourced from sustainably managed forests. Four-coat stain finish. Stain durability > 10 years. Salt air protective coating available upon request.

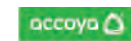

Finish

The finish shown is in Brume wood and Black 2100 sanded metal, code +.W01.M05. Finish options available in any of the standard shades from the AUBRILAM color chart. Please refer to page 35 of the catalog. Other colors available upon request.

Wood

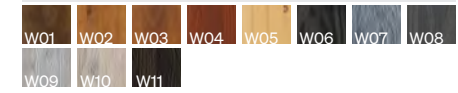

Metal

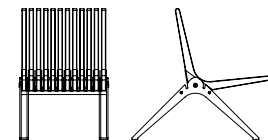
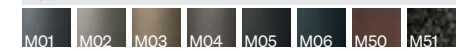

FID0001 1-seater bench
610 × 875 mm • H.905 mm
FID0002 2-seater bench
1,260 × 875 mm • H.905 mm

FID0003 3-seater bench
1,860 × 875 mm • H.905 mm
FID0004 4-seater bench
2,460 × 875 mm • H.905 mm

FID0005 5-seater bench
3,060 × 875 mm • H.905 mm
FID0006 6-seater bench
3,660 × 875 mm • H.905 mm



Use
 Public squares, pathways, parks, or relaxation areas.

Materials
 Electrogalvanized steel structure with polyester powder coating. Seat made of solid Accoya® acetylated wood, sourced from sustainably managed forests. Four-coat stain finish. Stain durability > 10 years. Salt air protective coating available upon request.



Finish
 The finish shown is in Brume wood and Black 2100 sanded metal, code +.W01.M05. Finish options available in any of the standard shades from the AUBRILAM color chart. Please refer to page 35 of the catalog. Other colors available upon request.

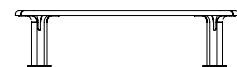
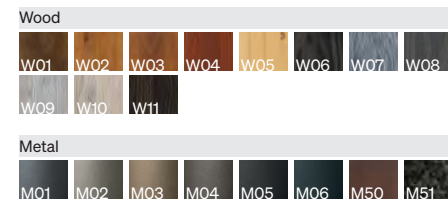

FUT0004 Tree surround bench
 □ 1.80 m • H 450 mm



Use
 Public squares, pathways, parks, or relaxation areas.

Materials
 Aluminum structure with polyester powder coating. Solid wood tabletop made of sustainably managed solid Accoya® acetylated wood. Four-coat stain finish. Stain durability > 10 years. Salt air protective coating available upon request.



Finish
 The finish shown is in Brume wood and Black 2100 sanded metal, code +.W01.M05. Finish options available in any of the standard shades from the AUBRILAM color chart. Please refer to page 35 of the catalog. Other colors available upon request.

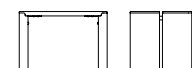
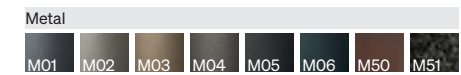
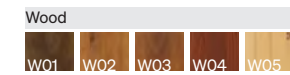

FSK1000 Coffee table
 598 x 420 mm • H 400 mm



Use
 Areas for relaxation, rest, and leisure.

Materials
 Electrogalvanized steel structure with polyester powder coating. Solid wood tabletop made of sustainably managed solid Accoya® acetylated wood. Four-coat stain finish. Stain durability > 10 years. Salt air protective coating available upon request.

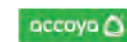

Finish
 The finish shown is in Brume wood and Black 2100 sanded metal, code +W01.M05. Finish options available in any of the standard shades from the AUBRILAM color chart. Please refer to page 35 of the catalog. Other colors available upon request.

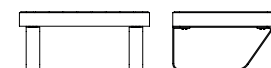
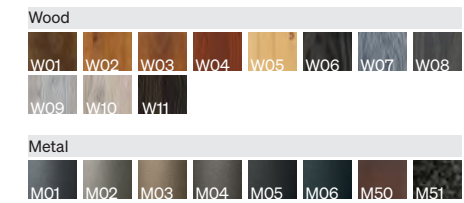

FRV1000 Coffee table
 960 x 430 mm • H 750 mm

- Set with table and 2 seats
- Set with table and 4 seats
- Set with table and 6 seats
- Set with table and 4 seats comfort
- Set with high table and 2 seats
- Set with high table and 8 seats
- T lounge area set
- V lounge area set
- Planters



Use
Restaurant terraces.

Materials
Aluminum structure with polyester powder coating. Tabletop and seats in 12 mm compact laminate. Salt air protective coating available upon request.

Option
Tables and seating may be sold separately.

Finish
The finish presented is in compact laminate O935NT Voyager and Black 2200 sanded metal, code +.H03.M06. Metallic finish options available in any of the standard shades from the AUBRILAM color chart. Please refer to page 35 of the catalog. Other colors available upon request.

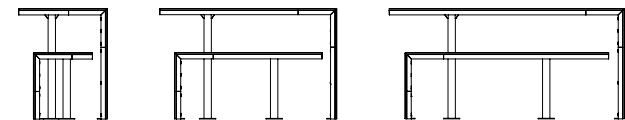
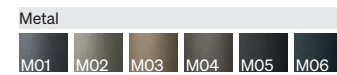
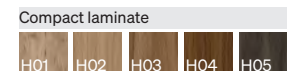

- FCO3000 Set with table and 2 seats**
- FCO1000 2-seater table 602 × 642 mm • H 750 mm
- FCO0001 Stool 402 × 350 mm • H 450 mm
- FCO3001 Set with table and 4 seats**
- FCO1001 4-seater table 1,202 × 642 mm • H 750 mm
- FCO0002 2-seater bench 1,002 × 350 mm • H 450 mm
- FCO3003 Set with table and 6 seats**
- FCO1003 6-seater table 1,602 × 642 mm • H 750 mm
- FCO0004 3-seater bench 1,387 × 350 mm • H 450 mm

- Set with table and 2 seats
- Set with table and 4 seats
- Set with table and 6 seats
- Set with table and 4 seats comfort**
- Set with high table and 2 seats
- Set with high table and 8 seats
- T lounge area set
- V lounge area set
- Planters



Use
Restaurant terraces.

Materials
Aluminum structure with polyester powder coating. Tabletop and seats in 12 mm compact laminate. Foam cushions, Ferrari Stamskin Zen fabric. Salt air protective coating available upon request.

Option
Tables and seating may be sold separately.

Finish
The finish presented is in compact laminate 0935NT Voyager and Black 2200 sanded metal, code +.H03.M06. Metallic finish options available in any of the standard shades from the AUBRILAM color chart. Please refer to page 35 of the catalog. Other colors available upon request.

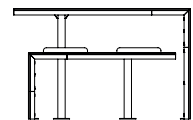
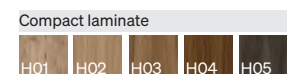

FCO3002 Set with table and 4 seats comfort
FCO1001 4-seater table 1,202 × 642 mm • H 750 mm
FCO0003 2-seater bench with cushions 1,002 × 350 mm • H 450 mm

- Set with table and 2 seats
- Set with table and 4 seats
- Set with table and 6 seats comfort
- Set with high table and 2 seats**
- Set with high table and 8 seats**
- T lounge area set
- V lounge area set
- Planters



Use
Restaurant terraces.

Materials
Aluminum structure with polyester powder coating. Tabletop and seats in 12 mm compact laminate. Salt air protective coating available upon request.

Option
Tables and seating may be sold separately.

Finish
The finish presented is in compact laminate 0935NT Voyager and Black 2200 sanded metal, code +.H03.M06. Metallic finish options available in any of the standard shades from the AUBRILAM color chart. Please refer to page 35 of the catalog. Other colors available upon request.

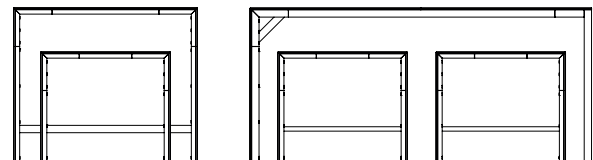
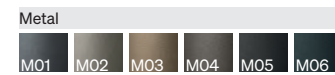
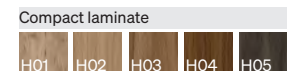

FCO4000 Set with high table and 2 seats
 FCO2000 2-seater high table 1,254 × 350 mm • H 1,050 mm
 FCO0005 2-seater high bench 884 × 350 mm • H 750 mm
FCO4001 Set with high table and 8 seats
 FCO2001 8-seater high table 2,332 × 800 mm • H 1,050 mm
 FCO0005 2-seater high bench 884 × 350 mm • H 750 mm

- Set with table and 2 seats
- Set with table and 4 seats
- Set with table and 6 seats
- Set with table and 4 seats comfort
- Set with high table and 2 seats
- Set with high table and 8 seats
- T lounge area set**
- V lounge area set**
- Planters

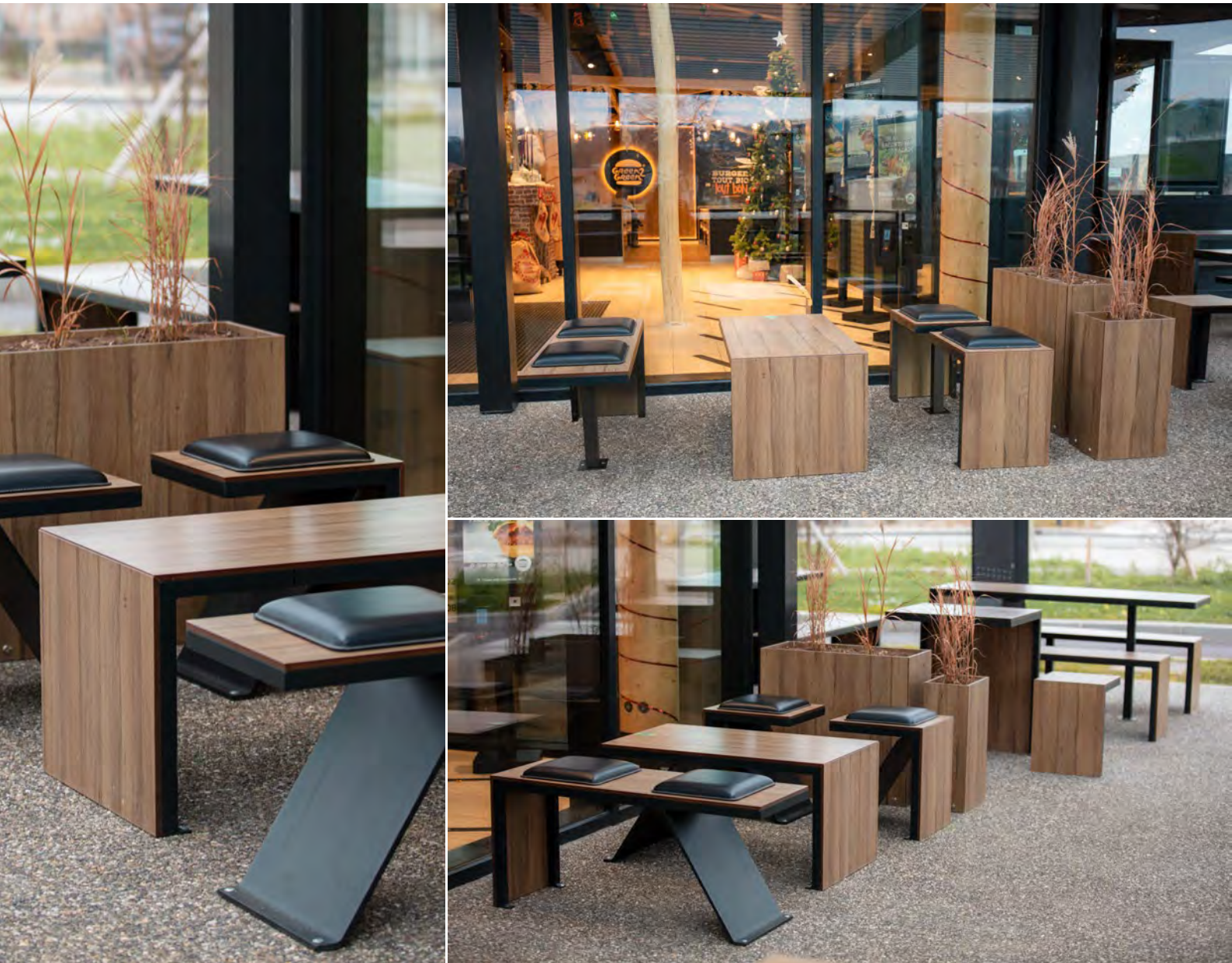

Use
Restaurant terraces.

Materials
Aluminum structure with polyester powder coating. Tabletop and seats in 12 mm compact laminate. Foam cushions, Ferrari Stamskin Zen fabric. Salt air protective coating available upon request.

Option
Tables and seating may be sold separately.

Finish
The finish presented is in compact laminate 0935NT Voyager and Black 2200 sanded metal, code +.H03.M06. Metallic finish options available in any of the standard shades from the AUBRILAM color chart. Please refer to page 35 of the catalog. Other colors available upon request.

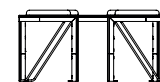
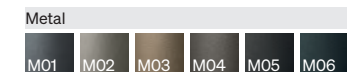
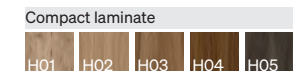

FCO3004 T lounge area set
FCO1004 Coffee table 902 × 500 mm • H 450 mm
FCO0007 2-seater bench 1,002 × 350 mm • H 450 mm
FCO0008 Stool 402 × 350 mm • H 450 mm

FCO3005 V lounge area set
FCO1005 Coffee table 902 × 500 mm • H 450 mm
FCO0009 2-seater bench 1,002 × 350 mm • H 450 mm
FCO0010 Stool 402 × 350 mm • H 450 mm

- Set with table and 2 seats
- Set with table and 4 seats
- Set with table and 6 seats
- Set with high table and 2 seats
- Set with high table and 4 seats
- Planters
- Litter bin
- Waste sorting units (4 types - 5 types)
- Ashtray
- Barrier
- Wind protection



Use
Restaurant terraces, relaxation and picnic areas.

Materials
Electrogalvanized steel structure with polyester powder coating. Tabletop and seats in compact laminate, thickness of 12 mm. Salt air protective coating available upon request.

Option
Table may be fitted with a parasol stand featuring a locking mechanism. Tables and seating may be sold separately.

Finish
The finish presented is in compact laminate 0801NT Fir Platinum and Black 2200 sanded metal, code +.H01.M06. Metallic finish options available in any of the standard shades from the AUBRILAM color chart. Please refer to page 35 of the catalog. Other colors available upon request.

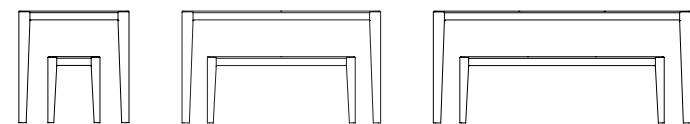
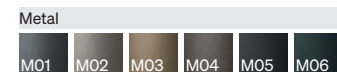
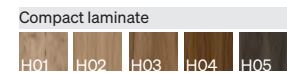

- FSL3000 Set with table and 2 seats**
- FSL1000 2-seater table 750 x 750 mm • H 760 mm
- FSL0001 Stool 355 mm • H 450 mm
- FSL3001 Set with table and 4 seats**
- FSL1001 4-seater table 1,350 x 750 mm • H 760 mm
- FSL0002 2-seater bench 1,005 x 355 mm • H 450 mm
- FSL3002 Set with table and 6 seats**
- FSL1003 6-seater table 1,750 x 750 mm • H 750 mm
- FSL0003 3-seater bench 1,390 x 355 mm • H 450 mm

- Set with table and 2 seats
- Set with table and 4 seats
- Set with table and 6 seats
- Set with high table and 2 seats**
- Set with high table and 4 seats**
- Planters
- Litter bin
- Waste sorting units (4 types - 5 types)
- Ashtray
- Barrier
- Wind protection



Use
Restaurant terraces, relaxation and picnic areas.

Materials
Electrogalvanized steel structure with polyester powder coating. Tabletop and seats in compact laminate, thickness of 12 mm. Stainless steel footrest. Salt air protective coating available upon request.

Option
Tables and seating may be sold separately.

Finish
The finish presented is in compact laminate 0801NT Fir Platinum and Black 2200 sanded metal, code +.H01.M06. Metallic finish options available in any of the standard shades from the AUBRILAM color chart. Please refer to page 35 of the catalog. Other colors available upon request.

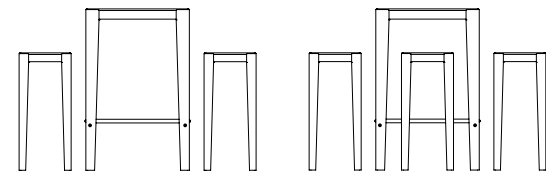
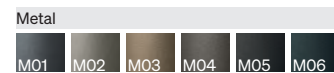
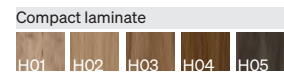

FSL4000 Set with high table and 2 seats
 FSL2000 2-seater table □ 706 mm • H 1,100 mm
 FSL0004 High stool □ 355 mm • H 800 mm
FSL4001 Set with high table and 4 seats
 FSL2000 4-seater high table □ 706 mm • H 1,100 mm
 FSL0004 High stool □ 355 mm • H 800 mm

- Set with table and 2 seats
- Set with table and 4 seats
- Set with table and 6 seats
- Set with table and 4 seats comfort
- Set with high table and 2 seats
- Set with high table and 8 seats
- T lounge area set
- V lounge area set
- Planters**



Use
Restaurant terraces.

Materials
Structure in 12 mm compact laminate. Geotextile included.

Finish
The finish presented is in compact laminate 0935NT Voyager, code +.H03. Finish options available in any of the standard shades from the AUBRILAM color chart. Please refer to page 35 of the catalog. Other colors available upon request.

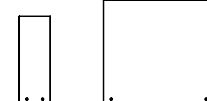
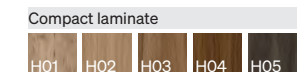

FC05000 Small planter
200 × 300 mm • H 550 mm
Capacity: 16 liters

FC05001 Large planter
700 × 300 mm • H 650 mm
Capacity: 63 liters

Set with table and 2 seats
 Set with table and 4 seats
 Set with table and 6 seats
 Set with high table and 2 seats
 Set with high table and 4 seats

Planters
 Litter bin
 Waste sorting units (4 types - 5 types)
 Ashtray
 Barrier
 Wind protection



Use
 Restaurant terraces, relaxation and picnic areas.

Materials
 Electrogalvanized steel structure with polyester powder coating. Rectangular body in compact laminate.
 Square planter: galvanized steel bin included.
 Rectangular planter: polyethylene bin included.
 Salt air protective coating available upon request.

Finish
 The finish presented is in compact laminate 0801NT Fir Platinum and Black 2200 sanded metal, code +.H01.M06. Finish options available in any of the standard shades from the AUBRILAM color chart. Please refer to page 35 of the catalog. Other colors available upon request.

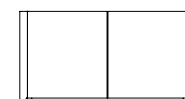
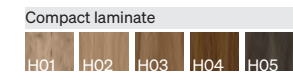

FSL5000 Square planter
 □ 555 mm • H 617 mm
 Capacity: 130 liters

FSL5001 Rectangular planter
 1,205 × 555 mm • H 617 mm
 Capacity: 260 liters



Use
 Public squares, pathways, parks, or relaxation areas.

Materials
 Electrogalvanized steel structure with polyester powder coating. Seat and backrest made of solid Accoya® acetylated wood, sourced from sustainably managed forests. Four-coat stain finish. Stain durability > 10 years. Salt air protective coating available upon request.



Finish
 The finish shown is in Brume wood and Black 2100 sanded metal, code +.W01.M05. Finish options available in any of the standard shades from the AUBRILAM color chart. Please refer to page 35 of the catalog. Other colors available upon request.

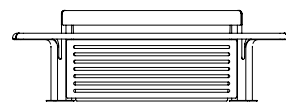
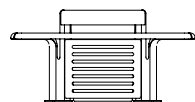
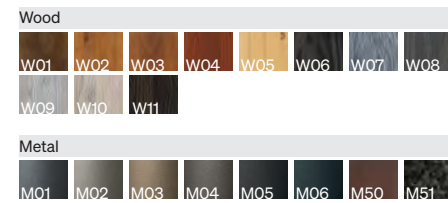

FUT5001 Square planter
 □ 1,256 mm • H 620 mm
 Capacity: 500 liters

FUT5002 Rectangular planter
 1,906 × 1,256 mm • H 620 mm
 Capacity: 1,000 liters



Use
 Public squares, pathways, parks, or relaxation areas.

Materials
 Electrogalvanized steel structure with polyester powder coating. Cladding in compact laminate, thickness of 12 mm. Polyethylene bin included. Salt air protective coating available upon request.

Finish
 The finish presented is in compact laminate 0924NT Taurus and Black 2100 sanded metal, code +.H04.M05. Finish options available in any of the standard shades from the AUBRILAM color chart. Please refer to page 35 of the catalog. Other colors available upon request.

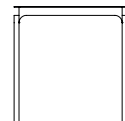
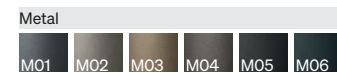
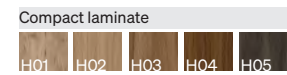

FUT5000 Planter
 □ 800 mm • H 820 mm
 Capacity: 280 liters



Use
 Public squares, pathways, parks, or relaxation areas.

Materials
 Electrogalvanized steel structure with polyester powder coating. Cladding made of molded plywood, laminate veneer on surfaces, and UV-resistant varnish on edges. Removable galvanized steel bin. Salt air protective coating available upon request.

Finish
 The finish presented is in compact laminate 0924NT Taurus and Black 2100 sanded metal, code +.H04.M05. Finish options available in any of the standard shades from the AUBRILAM color chart. Please refer to page 35 of the catalog. Other colors available upon request.

Compact laminate



Metal

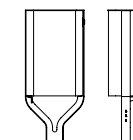

FUT8001 Litter bin
 400 × 248 mm • H 910 mm
 Capacity: 30 liters



Use
Public squares, pathways, parks, or relaxation areas.

Materials
Stainless steel structure with polyester powder coating. Cladding in solid Accoya® acetylated wood, sourced from sustainably managed forests. Four-coat stain finish. Stain durability > 10 years. Salt air protective coating available upon request.

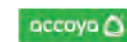

Option
Selective sorting colours on request.

Finish
The finish shown is in Brume wood and Black 2100 sanded metal, code +.W01.M05. Finish options available in any of the standard shades from the AUBRILAM color chart. Please refer to page 35 of the catalog. Other colors available upon request.

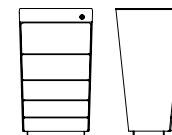
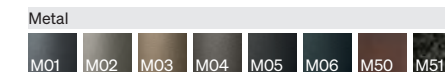
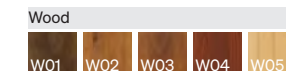

FN08000 Litter bin
500 x 457 mm • H 877 mm
Capacity: 60 liters

Litter bins

Skala

- Stools
- Chair
- Bench
- 2-seater bench
- Face-to-face bench
- Double bench
- Coffee table
- Litter bin**
- Skala lighting bollards
- Light building elements - 3.5 m - 4 m - 5 m
- Poles - 3.5 m to 5 m



Use
Public squares, pathways, parks, or relaxation areas.

Materials
Stainless steel structure with polyester powder coating. Cladding in solid Accoya® acetylated wood, sourced from sustainably managed forests. Four-coat stain finish. Stain durability > 10 years. Salt air protective coating available upon request.



Finish
The finish shown is in Brume wood and Black 2100 sanded metal, code +.W01.M05. Finish options available in any of the standard shades from the AUBRILAM color chart. Please refer to page 35 of the catalog. Other colors available upon request.

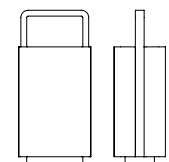
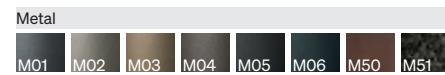
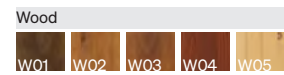

FSK8000 Litter bin
493 × 350 mm • H 1,050 mm
Capacity: 60 liters



Use

Areas for relaxation, rest, and leisure. Product compliant with Vigipirate criteria.

Materials

Electrogalvanized steel structure with polyester powder coating. Cladding in solid Accoya® acetylated wood, sourced from sustainably managed forests. Four-coat stain finish. Stain durability > 10 years. Salt air protective coating available upon request.

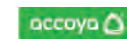

Finish

The finish shown is in Brume wood and Black 2100 sanded metal, code +.W01.M05. Finish options available in any of the standard shades from the AUBRILAM color chart. Please refer to page 35 of the catalog. Other colors available upon request.

Wood

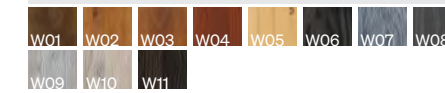

Metal

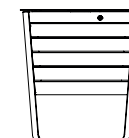
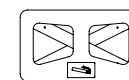

FRV8000 Litter bin
 □ 490 mm • H 911 mm
 Capacity: 80 liters

FRV9000 Selective sorting litter bin
 840 × 490 mm • H 911 mm
 Capacity: 2 × 80 liters

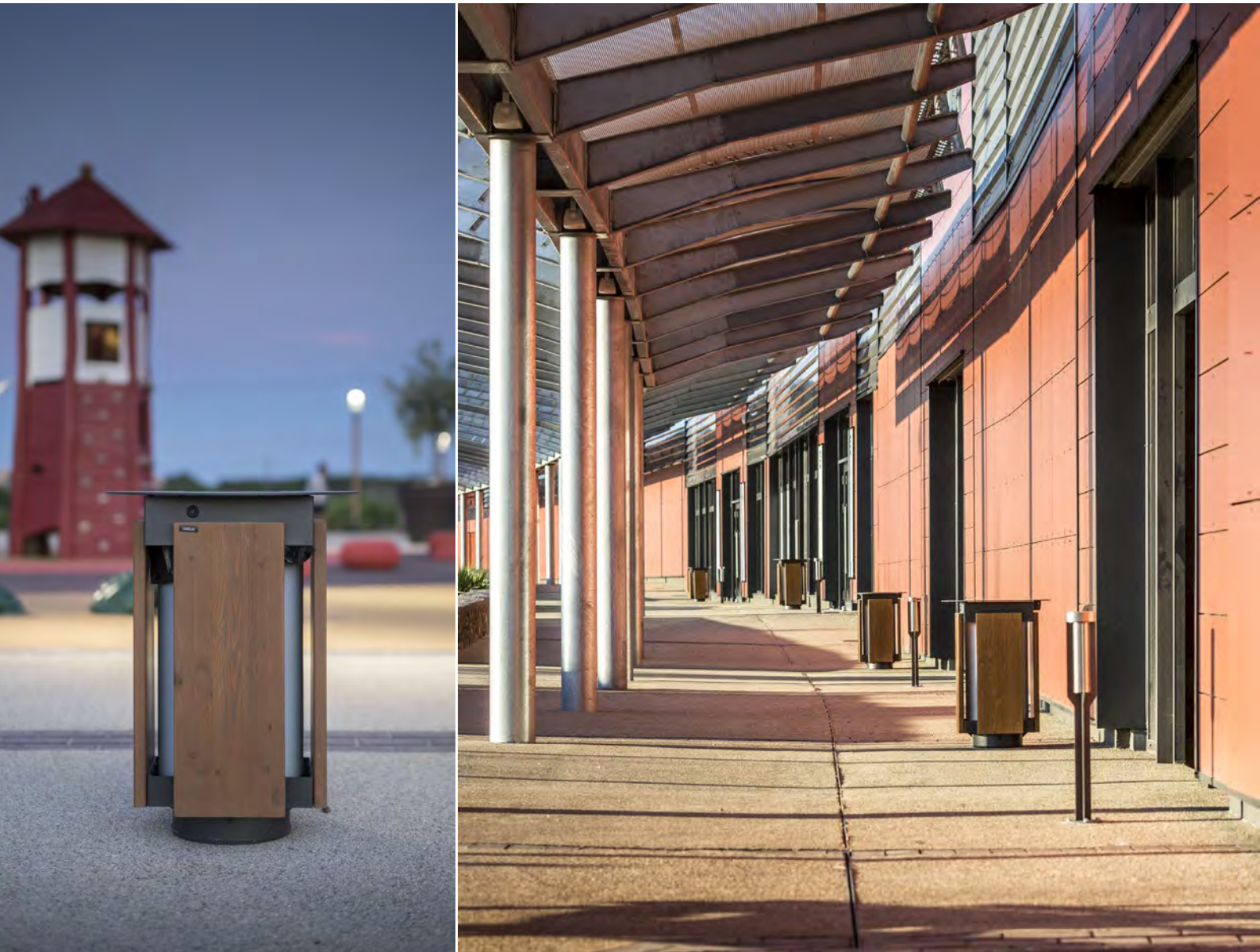

Use

Public squares, pathways, parks, or relaxation areas. Product compliant with Vigipirate criteria.

Materials

Square body composed of four panels made of sustainably sourced, solid Accoya® acetylated wood. Four-coat stain finish. Stain durability > 10 years. Cylindrical lid, lid support, and base made of galvanized steel with polyester powder coating. Polyethylene bin. Key lock with triangular key and hook cam. Salt air protective coating available upon request.

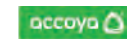

Finish

The finish shown is in Brume wood and Black 2100 sanded metal, code +W01.M05. Finish options available in any of the standard shades from the AUBRILAM color chart. Please refer to page 35 of the catalog. Other colors available upon request.

Wood



Metal

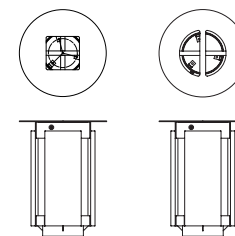

FM08000 Litter bin
 Ø 600 mm • H 808 mm
 Capacity: 60 liters

FM09000 Selective sorting litter bin
 Ø 600 mm • H 808 mm
 Capacity: 2 x 30 liters

Litter bins

Solea



Use
Restaurant terraces, relaxation and picnic areas.

Materials
Electrogalvanized steel structure with polyester powder coating. Panels in 12 mm compact laminate. Swinging flap made of galvanized steel. Polyethylene bin included. Salt air protective coating available upon request.

Option
Push-to-close lock available upon request.

Finish
The finish presented is in compact laminate 0801NT Fir Platinum and Black 2200 sanded metal, code +.H01.M06. Metallic finish options available in any of the standard shades from the AUBRILAM color chart. Please refer to page 35 of the catalog. Other colors available upon request.

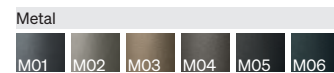
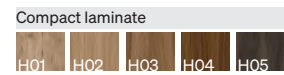

- Set with table and 2 seats
- Set with table and 4 seats
- Set with table and 6 seats
- Set with high table and 2 seats
- Set with high table and 4 seats
- Planters
- Litter bin**
- Waste sorting units (4 types - 5 types)
- Ashtray
- Barrier
- Wind protection

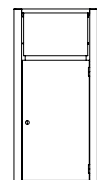

FSL8001 Litter bin
575 × 511 mm • H 1,204 mm
Capacity: 108 liters



Use
 Restaurant terraces.

Materials
 Electrogalvanized steel structure with polyester powder coating. Cladding in compact laminate, exterior 12 mm. Doors in 12 mm compact laminate. Salt air protective coating available upon request.

Characteristics
 Type 1: Stainless steel sink + hose + 20-liter jerrycan
 Type 2: 50-liter polyethylene bin
 Type 3: 50-liter polyethylene bin (FSL9001: 80-liter polyethylene bin)
 Type 4: 50-liter polyethylene bin
 Type 5: 50-liter polyethylene bin (FSL9001 only)

Finish
 The finish presented is in compact laminate 0801NT Fir Platinum and Black 2200 sanded metal, code +.H01.M06. Metallic finish options available in any of the standard shades from the AUBRILAM color chart. Please refer to page 35 of the catalog. Other colors available upon request.

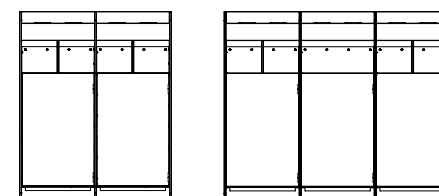
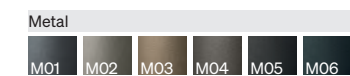
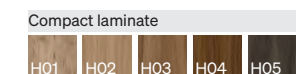

FSL9000 Waste sorting unit (4 types)
 1,046 × 548 mm • H 1,298 mm
FSL9001 Waste sorting unit (5 types)
 1,563 × 548 mm • H 1,298 mm

Ashtray

Utyl



Use
Public squares, pathways, parks, or relaxation areas.

Materials
Electrogalvanized steel structure with polyester powder coating. Removable stainless steel bin and lid, secured with a triangle key lock. Salt air protective coating available upon request.

Finish
The finish shown is in Black 2100 sanded metal, code +.M05. Finish options available in any of the standard shades from the AUBRILAM color chart. Please refer to page 35 of the catalog. Other colors available upon request.



FUT8000 Ashtray
Ø 115 mm • H 787 mm
Capacity: 0.75 liters

- Chairs
- 3-seater bench
- 3-seater slatted bench
- Tree surround bench
- Planters
- Litter bin
- Ashtray**
- Bollards
- Diapason bollards
- Bike rack
- Barrier

- Set with table and 2 seats
- Set with table and 4 seats
- Set with table and 6 seats
- Set with high table and 2 seats
- Set with high table and 4 seats
- Planters
- Litter bin
- Waste sorting units (4 types - 5 types)
- Ashtray**
- Barrier
- Wind protection



Use
Restaurant terraces, relaxation and picnic areas.

Materials
Electrogalvanized steel structure with polyester powder coating. Panels in 12 mm compact laminate.
Electrogalvanized steel bin. Salt air protective coating available upon request.

Finish
The finish presented is in compact laminate 0801NT Fir Platinum and Black 2200 sanded metal, code +.H01.M06. Metallic finish options available in any of the standard shades from the AUBRILAM color chart. Please refer to page 35 of the catalog. Other colors available upon request.

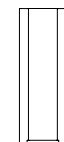
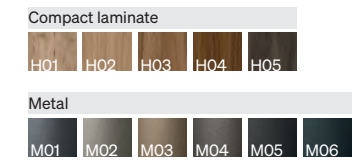

FSL8000 Ashtray
□ 273 mm • H 788 mm
Capacity: 1.80 liters



Use
 Public squares, pathways, parks, or relaxation areas.

Materials
 Electrogalvanized steel structure with polyester powder coating. Solid wood inserts made of sustainably managed solid Accoya® acetylated wood. Four-coat stain finish. Stain durability > 10 years. In PRM versions, the head is powder-coated in white. Salt air protective coating available upon request.



Option
 Removeable version available on request.

Finish
 The finish shown is in Brume wood and Black 2100 sanded metal, code +.W01.M05. Finish options available in any of the standard shades from the AUBRILAM color chart. Please refer to page 35 of the catalog. Other colors available upon request.

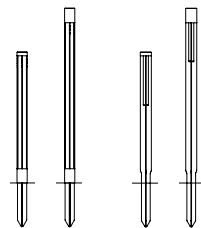
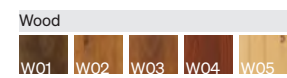

FUT7001 Bollard
 Ø 70 mm • H 900 mm
FUT7002 PRM bollard
 Ø 70 mm • H 1,200 mm

FUT7003 Diapason bollard
 Ø 70 mm • H 900 mm
FUT7004 Diapason PRM bollard
 Ø 70 mm • H 1,200 mm





Use
 Public squares, pathways, parks, or relaxation areas.

Materials
 Electrogalvanized steel structure with polyester powder coating. Cladding in solid Accoya® acetylated wood, sourced from sustainably managed forests. Four-coat stain finish. Stain durability > 10 years. Salt air protective coating available upon request.

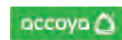

Finish
 The finish shown is in Brume wood and Black 2100 sanded metal, code +.W01.M05. Finish options available in any of the standard shades from the AUBRILAM color chart. Please refer to page 35 of the catalog. Other colors available upon request.

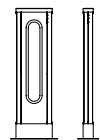
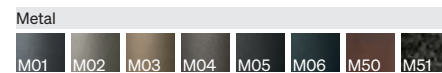
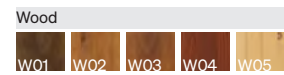

FUT7000 Bike rack
 250 x 70 mm • H 900 mm



Use
 Public squares, pathways, parks, or relaxation areas.

Materials
 Electro galvanized steel structure with polyester powder coating. Solid wood inserts made of sustainably managed solid Accoya® acetylated wood. Four-coat stain finish. Stain durability > 10 years. Salt air protective coating available upon request.

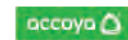

Finish
 The finish shown is in Brume wood and Black 2100 sanded metal, code +W01.M05. Finish options available in any of the standard shades from the AUBRILAM color chart. Please refer to page 35 of the catalog. Other colors available upon request.

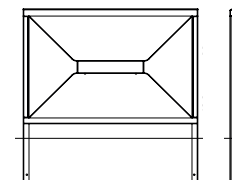
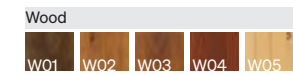

FUT6000 Barrier
 1,200 x 40 mm • H 890 mm

- Set with table and 2 seats
- Set with table and 4 seats
- Set with table and 6 seats
- Set with high table and 2 seats
- Set with high table and 4 seats
- Planters
- Litter bin
- Waste sorting units (4 types - 5 types)
- Ashtray
- Barrier**
- Wind shield



Use
Restaurant terraces, relaxation and picnic areas.

Materials
Aluminum structure with polyester powder coating. Panel in compact laminate, thickness of 12 mm. Salt air protective coating available upon request.

Finish
The finish presented is in compact laminate 0801NT Fir Platinum and Black 2200 sanded metal, code +.H01.M06. Metallic finish options available in any of the standard shades from the AUBRILAM color chart. Please refer to page 35 of the catalog. Other colors available upon request.

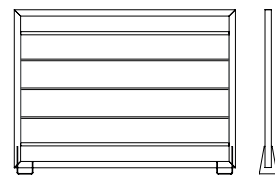
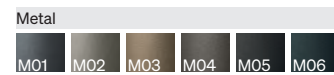
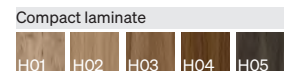

FSL6000 Barrier
1,400 x 40 mm • H 1,040 mm

- Set with table and 2 seats
- Set with table and 4 seats
- Set with table and 6 seats
- Set with high table and 2 seats
- Set with high table and 4 seats
- Planters
- Litter bin
- Waste sorting units (4 types - 5 types)
- Ashtray
- Barrier
- Wind protection**



Use
Restaurant terraces, relaxation and picnic areas.

Materials
Electrogalvanized steel structure with polyester powder coating. Clear laminated glass, thickness of 55.2. Salt air protective coating available upon request.

Finish
The finish shown is in Black 2200 sanded metal, code +.M06. Metallic finish options available in any of the standard shades from the AUBRILAM color chart. Please refer to page 35 of the catalog. Other colors available upon request.

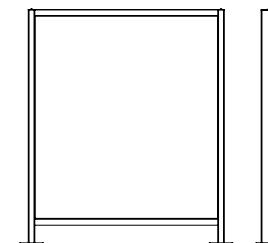
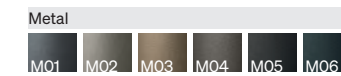

FSL6001 Wind shield
1,500 x 100 mm • H 1,800 mm



Use
 Public squares, pathways, parks, or relaxation areas.

Materials
 Electrogalvanized steel structure with polyester powder coating. Roofing in cellular polycarbonate, gutter in electrogalvanized steel. Salt air protective coating available upon request.

Finish
 The finish shown is in Black 2100 sanded metal, code +.M05. Finish options available in any of the standard shades from the AUBRILAM color chart. Please refer to page 35 of the catalog. Other colors available upon request.

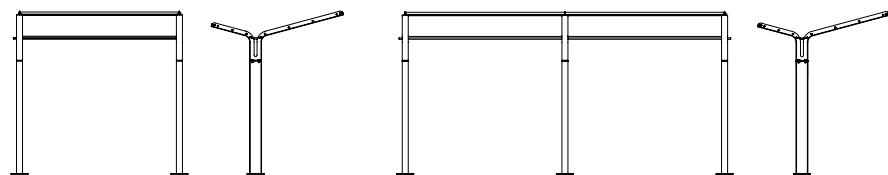
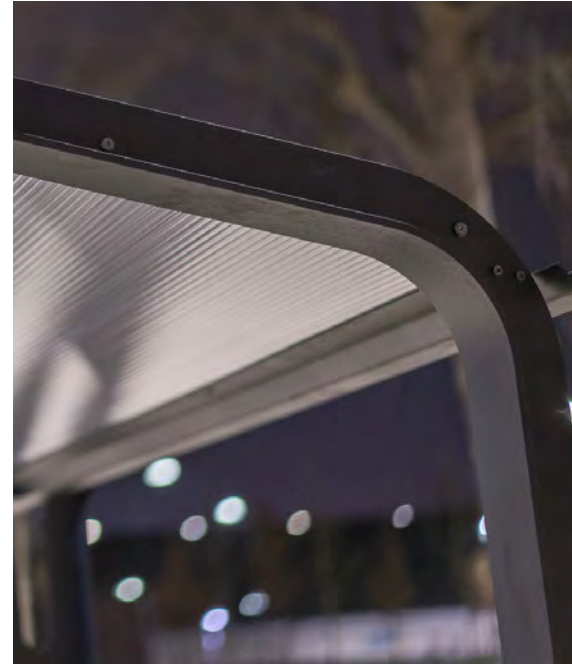
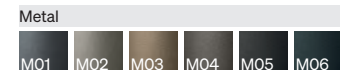

SUT0001 Single shelter
 2.51 x 2 m • H 2.45 m
 Capacity: 6 bikes
SUT0002 Double shelter
 4.93 x 2 m • H 2.46 m
 Capacity: 12 bikes



Use

Car parks.

Materials

Hot-dip galvanized steel structure, polyester powder coating. Roof with ribbed metal cladding. Salt air protective coating available upon request. SUT1001: wooden housing on the legs of the structure.

Finish

The finish shown is in Black 2100 sanded metal, code +.M05. Metallic finish options available in any of the standard shades from the AUBRILAM color chart. Please refer to page 35 of the catalog. Other colors available upon request.

Metal

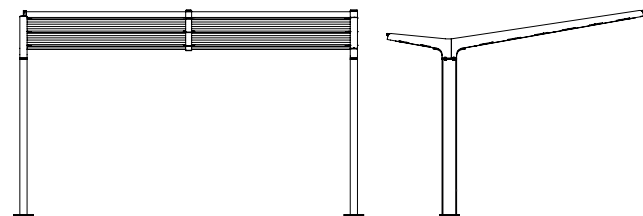
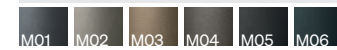

SUT1000 Shade
SUT1001 Shade with wood cladding
 5.11 × 3.92 m • H 3.10 m
 Capacity: 2 cars
SUT1002 PRM Shade
 3.42 × 3.92 m • H 3.10 m
 Capacity: 1 car



Use

Outdoor car parks.

Materials

Structure made of GL24H certified ACERBOIS GLULAM glued laminated timber, and designed using the HTE process, finished with a four-coat stain. Stain durability > 6 years. Base and roof connection piece made of galvanized steel, polyester powder coating. Single-sloped structure inclined at 10°, designed according to the Eurocode structural standards (0,13-4-5-7-8). Covered ground area of 25 m², providing a width of 2.60 m per parking space (covering 2 cars). Salt air protective coating available upon request.



Option

Photovoltaic module, lighting, signage, etc. available upon request.

Finish

The finish shown is in Brume wood and Black 2100 sanded metal, code +.W01.M05. Finish options available in any of the standard shades from the AUBRILAM color chart. Please refer to page 35 of the catalog. Other colors available upon request.

Wood

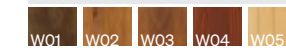

Metal

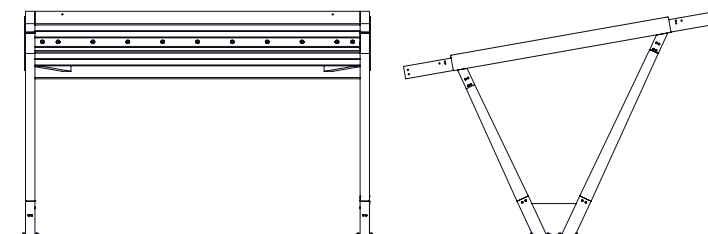
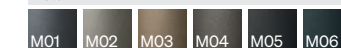

SAR1001 Steel sheet roofing - 28m/s
 SAR1002 Polycarbonate roofing - 24m/s
 SAR1003 Polycarbonate roofing - 28m/s
 5.65 x 5 m • H 3.40 m
 Capacity: 2 cars



Use
Plazas, parks, pedestrian pathways, or building surroundings.

Materials
Aluminum structure with polyester powder coating. Cladding and bench made of solid Accoya® acetylated wood, sourced from sustainably managed forests. Seating in compact laminate, thickness of 12 mm. Stadip Protect 44.2 laminated safety glass panel. Salt air protective coating available upon request.



Finish
The finish shown is in raw Accoya® wood and Black 2100 sanded metal, code +W00.M05. Finish options available in any of the standard shades from the AUBRILAM color chart. Please refer to page 35 of the catalog. Other colors available upon request.

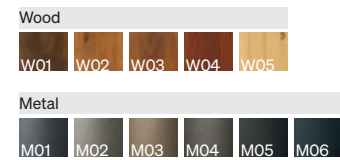

Technology
Product able to accommodate connectivity technologies:
- charging for one or multiple devices, with up to 5 charging points available via USB or wireless induction;
- lighting with 3 lighting points ranging from 15 to 20 lux;
- smart lighting control;
- electricity production and storage using solar panels.

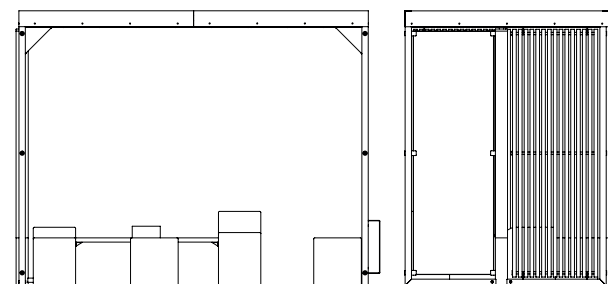

SHS0001 Connected space
3.30 x 1.90 m • H.2.59 m

Lighting points

Our ranges of lighting points offer a variety of bollards and building elements that cater to different uses and aesthetic environments. In our commitment to providing a comprehensive offering, certain products identified by their range name complement our ranges of urban furniture.

Creating harmony between light and material

Our primary raw material, wood, lends a distinctive identity to the products we design. Warm and organic, it creates a harmonious interplay between material and function. Our focus has been on crafting lighting points where material and light engage in a dialog. The light resonates with the natural wood, not only providing excellent illumination, but also accentuating the beauty of the material.



A responsible approach to lighting

Above all, a lighting point needs to provide high-quality, comfortable light. Our approach to lighting is rooted in BEGA's decades of experience.

As a result, we are able to offer high-performance, environmentally-friendly lighting solutions. Details about our Dark Sky and BugSaver® solutions can be found on pages 190-191 and 192-193 of this catalog.

Seamless integration into the environment

Our products are carefully crafted to enhance their surroundings both during the day as well as at night. We design each lighting point to be a harmonious and aesthetic unit.

We pay particular attention to integrating our luminaires into the surroundings to enhance public spaces, fulfilling functional needs after dark and standing as aesthetic pieces during daylight hours.

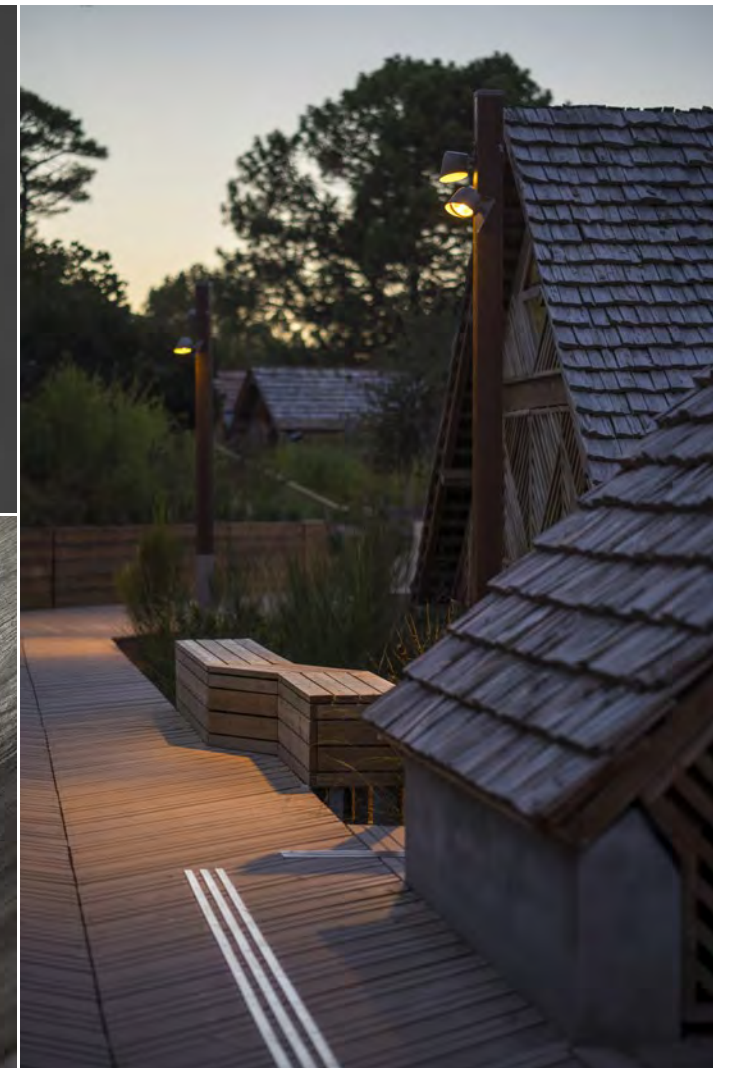



Camping Le Brasilia, Canet-en-Roussillon, France.



Lighting bollard with directional illumination
Square bollard made of sustainably sourced solid Accoya® acetylated wood. Wood with four-coat stain finish. Stain durability > 10 years.
Square galvanized steel base with polyester powder coating. Salt air protective coating available upon request.

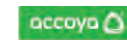

High-performance optical system with double recessed luminaires for asymmetric elliptical light distribution. Luminaire made of cast aluminum, aluminum, and stainless steel. Clear safety glass. Silicone seal.
DALI control
Protection class II

CE Compliance mark
Degree of protection: IP 65
Mechanical impact resistance: IK10

Connected power: 9 W
Luminaire luminous flux 3000 K: 648 lm
(2700 K: 630 lm - 2200 K: 506 lm)
Ambient temperature: $t_{a,max} = 55^\circ\text{C}$
Guaranteed availability of LED modules for 20 years.

Accessories
• Section \square 120 mm
DAC1000: Installation on finished ground
DAC1001: Installation on concrete base
• Section \square 140 mm
DAC1002: Installation on finished ground
DAC1003: Installation on concrete base

Finish
The finish shown is in Brume wood and Graphite metal, code +W01.M01.K3. Finish options available in any of the standard shades from the AUBRILAM color chart. Please refer to page 35 of the catalog. Other colors available upon request.

Wood

W01	W02	W03	W04	W05	W06	W07	W08
W09	W10	W11					

Metal

M01	M02	M03	M04	M05	M06	M50	M51
-----	-----	-----	-----	-----	-----	-----	-----

Lighting

K3	K27	K22
----	-----	-----

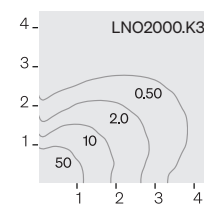
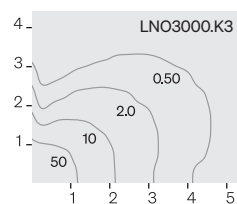

Recommended spacing for accessible pathways:

Notche 1	LNO3000.K3	LNO2000.K3
E_{min}	20 lux	29 lux
E_{max}	1 lux	1 lux
Spacing	8 m	6.50 m
Width	1.40 m	1.40 m

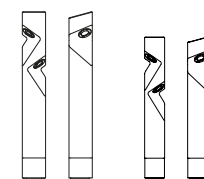

LNO3000 Notche 1 - High
LED 9 W • \square 140 mm • H 1 m
LNO2000 Notche 1 - Low
LED 9 W • \square 120 mm • H 0.85 m



Lighting bollard with directional illumination
Rectangular bollard made of sustainably sourced solid Accoya® acetylated wood. Wood with four-coat stain finish. Stain durability > 10 years.
Rectangular galvanized steel base with polyester powder coating. Salt air protective coating available upon request.

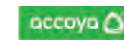

Efficient optical system with asymmetrical diffusion.
Luminaire made of cast aluminum, aluminum, and stainless steel. Safety glass with optical structure. Silicone seal.
DALI control
Class I protection (class II available on request)
Safety symbol
CE Compliance mark
Degree of protection: IP 65
Mechanical impact resistance: IK08

Connected power: 5.1 W
Luminaire luminous flux 3000 K: 277 lm
(2700 K: 267 lm - 2200 K: 201 lm - PC-Amber: 280 lm)
Ambient temperature: $t_{a,max} = 40\text{ }^{\circ}\text{C}$
Guaranteed availability of LED modules for 20 years.
✓ Compliant with the "light pollution" Decree of December 27, 2018.

Accessories
DAC1004: Installation on finished ground
DAC1005: Installation on concrete base

Finish
The finish shown is in Brume wood and Graphite metal, code +.W01.M01.K3. Finish options available in any of the standard shades from the AUBRILAM color chart. Please refer to page 35 of the catalog. Other colors available upon request.

Wood

W01	W02	W03	W04	W05	W06	W07	W08
W09	W10	W11					

Metal

M01	M02	M03	M04	M05	M06	M50	M51
-----	-----	-----	-----	-----	-----	-----	-----

Lighting

K3	K27	K22	K18
----	-----	-----	-----

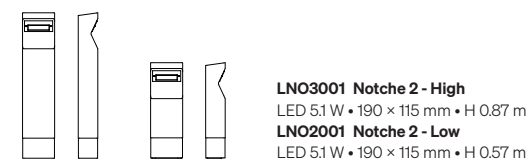
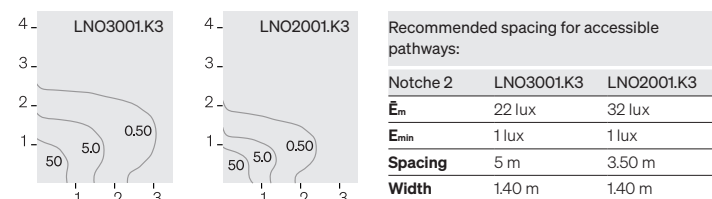



Lighting bollard with deflected lighting

Rectangular bollard made of sustainably sourced solid Accoya® acetylated wood. Wood with four-coat stain finish. Stain durability > 10 years.
 Rectangular galvanized steel base with polyester powder coating. Salt air protective coating available upon request.

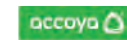

High-performance optical system with recessed luminaires for asymmetric elliptical light distribution. Luminaire made of cast aluminum and stainless steel. Safety glass with optical structure. Silicone optical lens.

DALI control
 Protection class II

 CE Compliance mark
 Degree of protection: IP 65
 Mechanical impact resistance: IK07

Connected power

1. Skala - High: 14 W
 Luminaire luminous flux 3000 K: 1,150 lm
 (2700 K: 1,102 lm - 2200 K: 1,093 lm)
 2. Skala - Low: 7,1 W
 Luminaire luminous flux 3000 K: 621 lm
 (2700 K: 595 lm - 2200 K: 590 lm)
 Ambient temperature: $t_{max} = 50\text{ }^{\circ}\text{C}$
 Guaranteed availability of LED modules for 20 years.

Accessories

DAC1013: Installation on finished ground
 DAC1014: Installation on concrete base

Finish

The finish shown is in Brume wood and Graphite metal, code +W01.M01.K3. Finish options available in any of the standard shades from the AUBRILAM color chart. Please refer to page 35 of the catalog. Other colors available upon request.

Wood

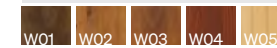

Metal

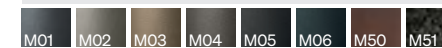

Lighting

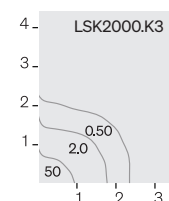
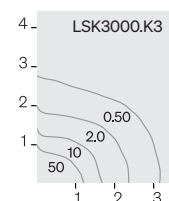

Recommended spacing for accessible pathways:

Skala	LSK3000.K3	LSK2000.K3
E_m	32 lux	34 lux
E_{min}	1 lux	1 lux
Spacing	6 m	4 m
Width	1.40 m	1.40 m

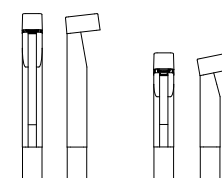

LSK3000 Skala - High
 LED 14 W • 200 × 120 mm • H 1 m
LSK2000 Skala - Low
 LED 7,1 W • 200 × 120 mm • H 0,75 m

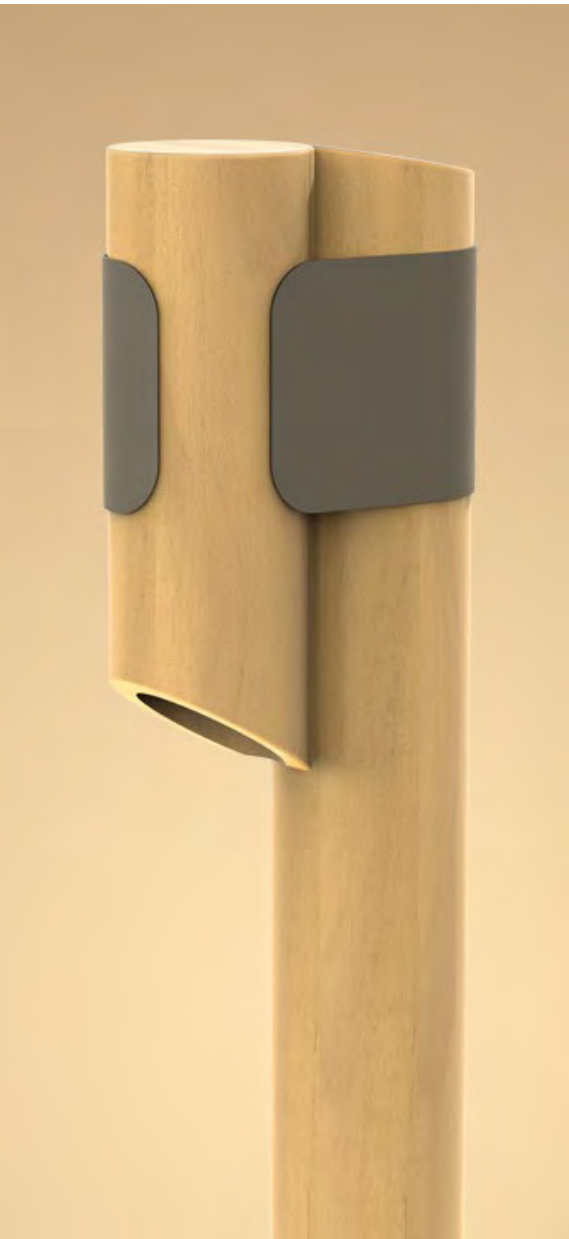

Lighting bollard with deflected lighting
Round bollard made of sustainably sourced Accoya® acetylated glued laminated timber. Wood with four-coat stain finish. Stain durability > 10 years.
Cladding and base made of galvanized steel, polyester powder coating. Salt air protective coating available upon request.

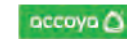

Optical system with symmetrical diffusion. Luminaire made of cast aluminum, aluminum, and stainless steel. Clear safety glass. Silicone seal.
DALI control
Protection class II

CE Compliance mark
Degree of protection: IP 65
Mechanical impact resistance: IK10

Connected power: 4.5 W
Luminaire luminous flux 3000 K: 324 lm
(2700 K: 315 lm - 2200 K: 253 lm)
Ambient temperature: $t_{a,max} = 55\text{ °C}$
Guaranteed availability of LED modules for 20 years.

Accessories
DAC1008: Installation on finished ground
DAC1009: Installation on concrete base

Finish
The finish shown is in Brume wood and Graphite metal, code +W01.M01.K3. Finish options available in any of the standard shades from the AUBRILAM color chart. Please refer to page 35 of the catalog. Other colors available upon request.

Wood							
W01	W02	W03	W04	W05	W06	W07	W08
W09	W10	W11					
Metal							
M01	M02	M03	M04	M05	M06	M50	M51
Lighting							
K3	K27	K22					

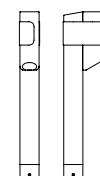

LSO3000 Solina 1
LED 4.5 W • Ø 115 mm + Ø 130 mm • H 1 m



Lighting bollard with deflected lighting
 Round bollard made of sustainably sourced Accoya® acetylated glued laminated timber. Wood with four-coat stain finish. Stain durability > 10 years.
 Galvanized steel base with polyester powder coating. Salt air protective coating available upon request.

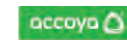

High-performance optical system with asymmetric elliptical light distribution. Luminaire made of cast aluminum, aluminum, and stainless steel. Clear safety glass. Silicone seal. DALI control
 Class I protection (class II available on request)
 Safety symbol
 CE Compliance mark
 Degree of protection: IP 65
 Mechanical impact resistance: IK06

Connected power: 6.7 W
 Luminaire luminous flux 3000 K: 479 lm
 (2700 K: 465 lm - 2200 K: 344 lm)
 Ambient temperature: $t_{a,max} = 45\text{ }^{\circ}\text{C}$
 Guaranteed availability of LED modules for 20 years.
 ✓ Compliant with the "light pollution" Decree of December 27, 2018.

Accessories
 DAC1008: Installation on finished ground
 DAC1009: Installation on concrete base

Finish
 The finish shown is in Brume wood and Graphite metal, code +.W01.M01.K3. Finish options available in any of the standard shades from the AUBRILAM color chart. Please refer to page 35 of the catalog. Other colors available upon request.

Wood

W01	W02	W03	W04	W05	W06	W07	W08
W09	W10	W11					

Metal

M01	M02	M03	M04	M05	M06	M50	M51
-----	-----	-----	-----	-----	-----	-----	-----

Lighting

K3	K27	K22
----	-----	-----

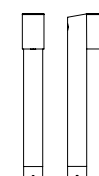
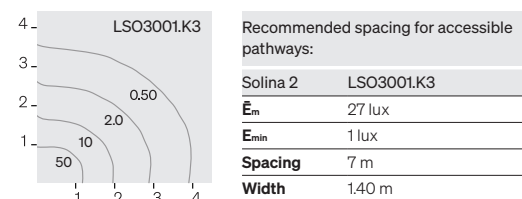
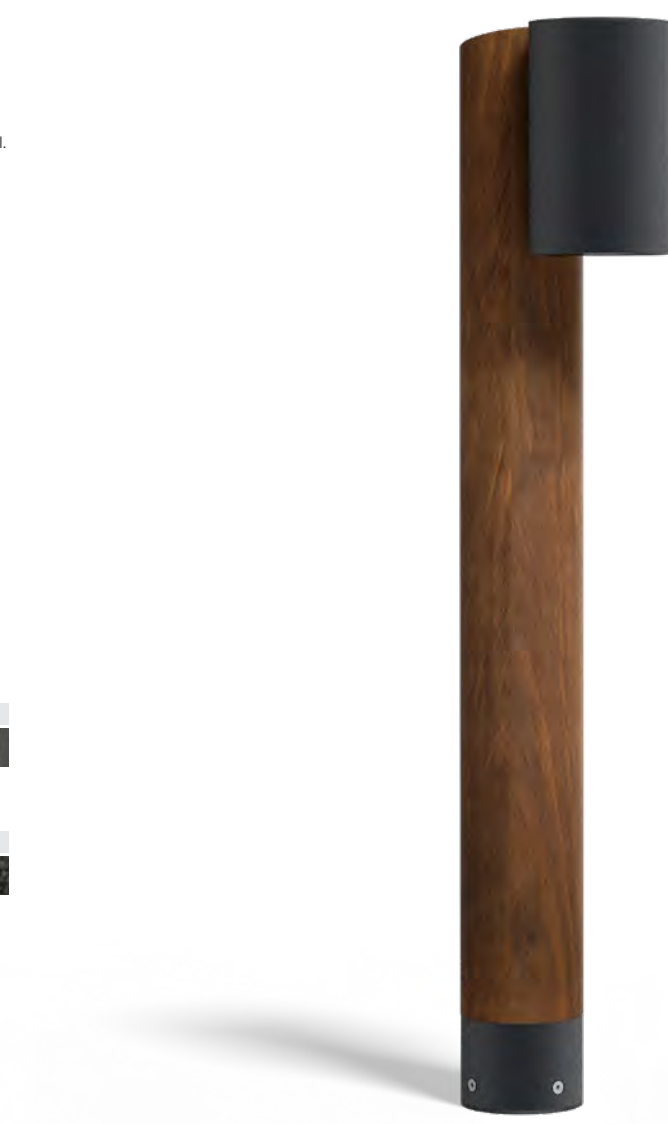

LSO3001 Solina 2
 LED 6.7 W • Ø 115 mm + Ø 130 mm • H 1 m



Lighting bollard with deflected lighting
Round bollard made of sustainably sourced Accoya® acetylated glued laminated timber. Wood with four-coat stain finish. Stain durability > 10 years.
Cladding made of 8 mm diameter rope. Round base in galvanized steel with polyester powder coating. Salt air protective coating available upon request.

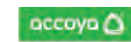

Optical system with symmetrical diffusion. Luminaire made of cast aluminum, aluminum, and stainless steel. Clear safety glass. Silicone seal.
DALI control
Protection class II

CE Compliance mark
Degree of protection: IP 65
Mechanical impact resistance: IK10

Connected power: 4.5 W
Luminaire luminous flux 3000 K: 324 lm
(2700 K: 315 lm - 2200 K: 253 lm)
Ambient temperature: $t_{a,max} = 55\text{ °C}$
Guaranteed availability of LED modules for 20 years.

Accessories
DAC1008: Installation on finished ground
DAC1009: Installation on concrete base

Finish
The finish shown is in La Mer wood and Random rust metal, code +W10.M50.K3. Finish options available in any of the standard shades from the AUBRILAM color chart. Please refer to page 35 of the catalog. Other colors available upon request.

Wood							
W01	W02	W03	W04	W05	W06	W07	W08
W09	W10	W11					

Metal						
M01	M02	M03	M04	M05	M06	M50
M51						

Lighting		
K3	K27	K22

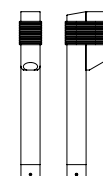

LSA3000 Sahari 1
LED 4.5 W • Ø 115 mm + Ø 135 mm • H 1 m



Lighting bollard with deflected lighting
 Round bollard made of sustainably sourced Accoya® acetylated glued laminated timber. Wood with four-coat stain finish. Stain durability > 10 years.
 Cladding made of 8 mm diameter rope. Round base in galvanized steel with polyester powder coating. Salt air protective coating available upon request.

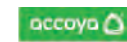

High-performance optical system with asymmetric elliptical light distribution. Luminaire made of cast aluminum, aluminum, and stainless steel. Clear safety glass.
 Silicone seal.
 DALI control
 Class I protection (class II available on request)
 Safety symbol
 CE Compliance mark
 Degree of protection: IP 65
 Mechanical impact resistance: IK06

Connected power: 6.7 W
 Luminaire luminous flux 3000 K: 479 lm
 (2700 K: 465 lm - 2200 K: 344 lm)
 Ambient temperature: $t_{amb} = 45\text{ }^{\circ}\text{C}$
 Guaranteed availability of LED modules for 20 years.
 ✓ Compliant with the "light pollution" Decree of December 27, 2018.

Accessories
 DAC1008: Installation on finished ground
 DAC1009: Installation on concrete base

Finish
 The finish shown is in La Mer wood and Random rust metal, code +W10.M50.K3. Finish options available in any of the standard shades from the AUBRILAM color chart. Please refer to page 35 of the catalog. Other colors available upon request.

Wood

W01	W02	W03	W04	W05	W06	W07	W08
W09	W10	W11					

Metal

M01	M02	M03	M04	M05	M06	M50	M51
-----	-----	-----	-----	-----	-----	-----	-----

Lighting

K3	K27	K22
----	-----	-----

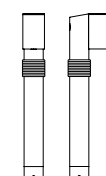
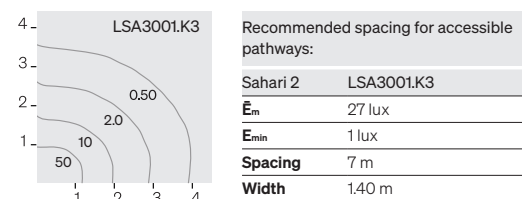

LSA3001 Sahari 2
 LED 6.7 W • Ø 115 mm + Ø 130 mm • H 1 m



Lighting bollard with deflected lighting

Rectangular bollard made of sustainably sourced solid Accoya® acetylated wood. Wood with four-coat stain finish. Stain durability > 10 years.
Rectangular galvanized steel base with polyester powder coating. Salt air protective coating available upon request.

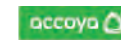

Efficient optical system with asymmetrical elliptical diffusion. Luminaire made of cast aluminum, aluminum, and stainless steel. Safety glass with optical structure. Silicone seal. DALI control. Available on request for LSE2001 and LSE2000. Class I protection (class II available on request)
☞ Safety symbol
CE Compliance mark
Degree of protection: IP 65
Mechanical impact resistance: IK09 (1) • IK10 (2)

Connected power

1. Sensy - High: 6.4 W
Luminaire luminous flux 3000 K: 461 lm
(2700 K: 447 lm - 2200 K: 359 lm)
2. Sensy - Medium / Low: 4 W
Luminaire luminous flux 3000 K: 266 lm
(2700 K: 256 lm - 2200 K: 207 lm)
Ambient temperature: $t_{a,max} = 60\text{ °C (1)} \cdot 45\text{ °C (2)}$
Guaranteed availability of LED modules for 20 years.
✓ Compliant with the "light pollution" Decree of December 27, 2018.

Accessories

• Section 190 × 115 mm
DAC1004: Installation on finished ground
DAC1005: Installation on concrete base
• Section 242 × 117 mm
DAC1006: Installation on finished ground
DAC1007: Installation on concrete base

Finish

The finish shown is in Brume wood and Graphite metal, code +.W01.M01.K3. Finish options available in any of the standard shades from the AUBRILAM color chart. Please refer to page 35 of the catalog. Other colors available upon request.

Wood

W01	W02	W03	W04	W05	W06	W07	W08
W09	W10	W11					

Metal

M01	M02	M03	M04	M05	M06	M50	M51
-----	-----	-----	-----	-----	-----	-----	-----

Lighting

K3	K27	K22
----	-----	-----

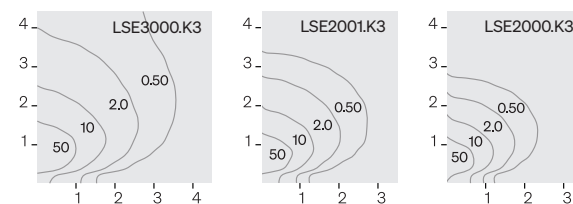

Recommended spacing for accessible pathways:

Sensy	LSE3000.K3	LSE2001.K3	LSE2000.K3
E_m	30 lux	22 lux	26 lux
E_{min}	1 lux	1 lux	1 lux
Spacing	6 m	5 m	4 m
Width	1.40 m	1.40 m	1.40 m

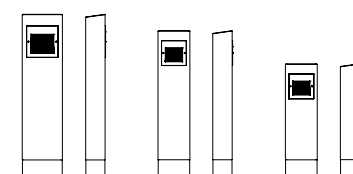

LSE3000 Sensy - High
LED 6.4 W • 242 × 117 mm • H 1 m
LSE2001 Sensy - Medium
LED 4 W • 190 × 115 mm • H 0.90 m
LSE2000 Sensy - Low
LED 4 W • 190 × 115 mm • H 0.70 m



Lighting bollard with deflected lighting

Square bollard made of sustainably sourced solid Accoya® acetylated wood. Wood with four-coat stain finish. Stain durability > 10 years.
Square galvanized steel base with polyester powder coating. Salt air protective coating available upon request.

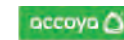

Optical system with asymmetrical diffusion. Luminaire made of cast aluminum, aluminum, and stainless steel. White safety glass.
On/Off (DALI control on request)
Class I protection (class II available on request)
Safety symbol
CE Compliance mark
Degree of protection: IP 65
Mechanical impact resistance: IK10

Connected power: 2.7 W

Luminaire luminous flux 3000 K: 95 lm (2700 K: 93 lm)
Ambient temperature: $t_{a,max} = 60\text{ }^{\circ}\text{C}$
Guaranteed availability of LED modules for 20 years.
✓ Compliant with the "light pollution" Decree of December 27, 2018.

Accessories

DAC1000: Installation on finished ground
DAC1001: Installation on concrete base

Finish

The finish shown is in Brume wood and Graphite metal, code +.W01.M01.K3. Finish options available in any of the standard shades from the AUBRILAM color chart. Please refer to page 35 of the catalog. Other colors available upon request.

Wood

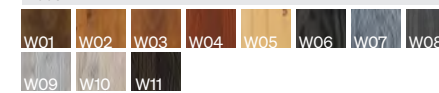

Metal

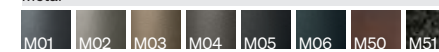

Lighting

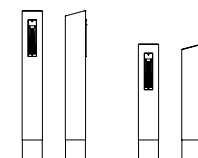

LMO3000 Moshi 1 - High
LED 2.7 W • □ 120 mm • H 0.90 m
LMO2000 Moshi 1 - Low
LED 2.7 W • □ 120 mm • H 0.70 m



Lighting bollard with directional illumination
 Square bollard made of sustainably sourced solid Accoya® acetylated wood. Wood with four-coat stain finish. Stain durability > 10 years.
 Square galvanized steel base with polyester powder coating. Salt air protective coating available upon request.

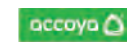

Optical system with asymmetrical elliptical diffusion.
 Luminaire made of cast aluminum, aluminum, and stainless steel. Clear safety glass. Silicone seal.
 On/Off (DALI control on request)
 Class I protection (class II available on request)
 ⚡ Safety symbol
 CE Compliance mark
 Degree of protection: IP 64
 Mechanical impact resistance: IK07

Connected power: 5.1 W
 Luminaire luminous flux 3000 K: 384 lm
 (2700 K: 371 lm - 2200 K: 344 lm)
 Ambient temperature: $t_{a,max} = 45\text{ }^{\circ}\text{C}$
 Guaranteed availability of LED modules for 20 years.
 ✓ Compliant with the "light pollution" Decree of December 27, 2018.

Finish
 The finish shown is in Brume wood and Graphite metal, code +.W01.M01.K3. Finish options available in any of the standard shades from the AUBRILAM color chart. Please refer to page 35 of the catalog. Other colors available upon request.

Wood							
W01	W02	W03	W04	W05	W06	W07	W08
W09	W10	W11					
Metal							
M01	M02	M03	M04	M05	M06	M50	M51
Lighting							
K3	K27	K22					

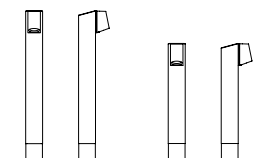

LMO3001 Moshi 2 - High
 LED 5.1 W • □ 100 mm • H 0.90 m
LMO2001 Moshi 2 - Low
 LED 5.1 W • □ 100 mm • H 0.70 m



Lighting bollard with directional illumination

Square bollard made of sustainably sourced solid Accoya® acetylated wood. Wood with four-coat stain finish. Stain durability > 10 years.

Square galvanized steel base with polyester powder coating. Salt air protective coating available upon request.

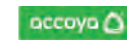

Optical system with elliptical diffusion. Luminaire made of cast aluminum, aluminum, and stainless steel. Clear safety glass. Silicone seal.

On/Off (DALI control on request)

Class I protection (class II available on request)

☞ Safety symbol

CE Compliance mark

Degree of protection: IP 64

Mechanical impact resistance: IK06

Connected power: 2.7 W

Luminaire luminous flux 3000 K: 198 lm

(2700 K: 192 lm - 2200 K: 144 lm)

Ambient temperature: $t_{a,max} = 60\text{ }^{\circ}\text{C}$

Guaranteed availability of LED modules for 20 years.

✓ Compliant with the "light pollution" Decree of December 27, 2018.

Accessories

DAC1000: Installation on finished ground

DAC1001: Installation on concrete base

Finish

The finish shown is in Brume wood and Graphite metal, code +.W01.M01.K3. Finish options available in any of the standard shades from the AUBRILAM color chart. Please refer to page 35 of the catalog. Other colors available upon request.

Wood

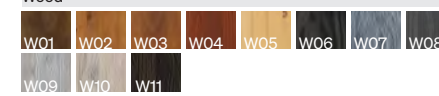

Metal



Lighting

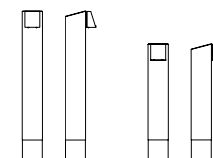

LMO3002 Moshi 3 - High
LED 2.7 W • □ 120 mm • H 0.90 m
LMO2002 Moshi 3 - Low
LED 2.7 W • □ 120 mm • H 0.70 m



Light building element with directional illumination
Square light building element made of GL24H certified ACERBOIS GLULAM glued laminated timber, sourced from sustainably managed forests and designed using the HTE process. Wood with four-coat stain finish. Stain durability > 6 years.
Base and lid made of galvanized steel, projector support in electrogalvanized steel, polyester powder coating. CE marked product. CE Certificate of conformity 0679-CPR-0473. Salt air protective coating available upon request.



High-Performance Optical System equipped with a projector providing diffuse symmetrical light distribution (other optics available on request). Luminaire made of cast aluminum, aluminum, and stainless steel. Clear safety glass. Silicone seal. Stainless steel visor.

DALI control
Protection class I
Safety symbol
CE Compliance mark
Degree of protection: IP 65
Mechanical impact resistance: IK08 (1) • IK09 (2)

Connected power
1. Notche □ 140 mm: 19 W
Luminaire luminous flux 3000 K: 1,911 lm
(2700 K: 1,833 lm - 2200 K: 2,142 lm)
2. Notche □ 160 mm: 40 W
Luminaire luminous flux 3000 K: 3,857 lm
(2700 K: 3,707 lm - 2200 K: 4,318 lm)
Ambient temperature: $t_{max} = 50\text{ °C}$ (1) • 35 °C (2)
Guaranteed availability of LED modules for 20 years.

Accessories
Elliptical lens for modifying light distribution.
Available with a ground spike base.



Finish
The finish shown is in Brume wood and Graphite metal, code +W01.M01.K3. Finish options available in any of the standard shades from the AUBRILAM color chart. Please refer to page 35 of the catalog. Other colors available upon request.

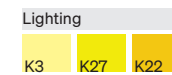
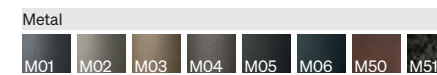
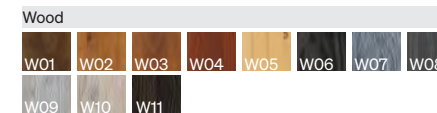

LNO0402 2 spotlights
2 x LED 19 W • □ 140 mm • H 4 m
LNO0403 3 spotlights
3 x LED 19 W • □ 140 mm • H 4 m

LNO0502 2 spotlights
2 x LED 19 W • □ 140 mm • H 5 m
LNO0503 3 spotlights
3 x LED 19 W • □ 140 mm • H 5 m
LNO0504 4 spotlights
4 x LED 19 W • □ 140 mm • H 5 m

LNO0602 2 spotlights
2 x LED 40 W • □ 160 mm • H 6 m
LNO0603 3 spotlights
3 x LED 40 W • □ 160 mm • H 6 m
LNO0604 4 spotlights
4 x LED 40 W • □ 160 mm • H 6 m



Light building element with deflected illumination
Rectangular light building element made of sustainably sourced solid Accoya® acetylated wood. Wood with four-coat stain finish. Stain durability > 10 years. Base, brackets, and head in galvanized steel with polyester powder coating. Salt air protective coating available upon request.

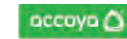

High-performance optical system with recessed luminaires for elliptical light distribution. Luminaire made of cast aluminum and stainless steel. Matte safety glass. Silicone optical lens.
DALI control
Protection class II
 Safety symbol
 CE Compliance mark
Degree of protection: IP 65
Mechanical impact resistance: IK07

Connected power: 19.6 W
Luminaire luminous flux 3000 K: 1,905 lm
(2700 K: 1,815 lm - 2200 K: 1,800 lm)
Ambient temperature: $t_{amb} = 35\text{ }^{\circ}\text{C}$
Guaranteed availability of LED modules for 20 years.

Accessories
Available with a ground spike base.

Finish
The finish shown is in Brume wood and Graphite metal, code +W01.M01.K3. Finish options available in any of the standard shades from the AUBRILAM color chart. Please refer to page 35 of the catalog. Other colors available upon request.

Wood

W01 W02 W03 W04 W05

Metal

M01 M02 M03 M04 M05 M06 M50 M51

Lighting

K3 K27 K22

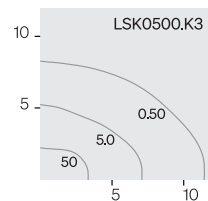
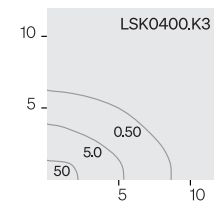

Recommended spacing for accessible pathways:

Skala	LSK0350.K3	LSK0400.K3	LSK0500.K3
E_m	25 lux	22 lux	26 lux
E_{min}	1 lux	1 lux	1 lux
Spacing	15 m	16 m	23 m
Width	2 m	2 m	2 m

LSK0350
LED 19.6 W • 145 × 140 mm • H 3.5 m
LSK0400
LED 19.6 W • 145 × 140 mm • H 4 m
LSK0500
2 x LED 19.6 W • 145 × 140 mm • H 5 m





Light building element with deflected illumination
Cylindrical light building element made of GL24H certified ACERBOIS GLULAM glued laminated timber, sourced from sustainably managed forests and designed using the HTE process. Wood with four-coat stain finish. Stain durability > 6 years.
Galvanized steel base and lid, with polyester powder coating. CE marked product: CE Certificate of conformity 0679-CPR-0473. Salt air protective coating available upon request.



High-performance optical system with wall-mounted luminaire featuring elliptical asymmetric distribution. Aluminum body with polyester powder coating. Silicone optical lens.
DALI control
Protection class I
Safety symbol
CE Compliance mark
Degree of protection: IP 65
Mechanical impact resistance: IK06

Connected power
1. Small Model: 22.5 W
Luminaire luminous flux 3000 K: 2,357 lm (2700 K: 2,284 lm - 2200 K: 1,700 lm)
2. Large Model: 33 W
Luminaire luminous flux 3000 K: 3,700 lm (2700 K: 3,600 lm - 2200 K: 2,900 lm)
Ambient temperature: $t_{a,max} = 45\text{ }^{\circ}\text{C}$
Guaranteed availability of LED modules for 20 years.

Accessories
Available with a ground spike base.



Finish
The finish shown is in Brume wood and Graphite metal, code +W01.M01.K3. Finish options available in any of the standard shades from the AUBRILAM color chart. Please refer to page 35 of the catalog. Other colors available upon request.

Wood							
W01	W02	W03	W04	W05	W06	W07	W08
W09	W10	W11					

Metal							
M01	M02	M03	M04	M05	M06	M50	M51

Lighting		
K3	K27	K22

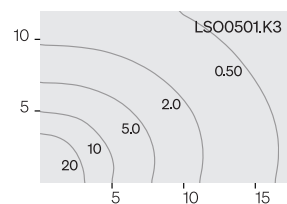
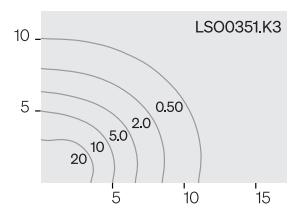

LSO0351 Single
LED 22.5 W • Ø 140 mm • H 3.5 m
LSO0352 Double
2 x LED 22.5 W • Ø 140 mm • H 3.5 m

LSO0401 Single
LED 33 W • Ø 140 mm • H 4 m
LSO0402 Double
SM - LED 22.5 W • Ø 140 mm • H 4 m
LM - LED 33 W • Ø 140 mm • H 4 m

LSO0501 Single
LED 33 W • Ø 140 mm • H 5 m
LSO0502 Double
SM - LED 22.5 W • Ø 140 mm • H 5 m
LM - LED 33 W • Ø 140 mm • H 5 m



Light building element with deflected illumination

Cylindrical light building element made of GL24H certified ACERBOIS GLULAM glued laminated timber, sourced from sustainably managed forests and designed using the HTE process. Wood with four-coat stain finish. Stain durability > 6 years.
Galvanized steel base and lid, with polyester powder coating.
CE marked product: CE Certificate of conformity 0679-CPR-0473. Salt air protective coating available upon request.



High-performance optical system with wall-mounted luminaire featuring elliptical asymmetric distribution. Aluminum body with polyester powder coating. Silicone optical lens.
DALI control
Protection class I
Safety symbol
Compliance mark
Degree of protection: IP 65
Mechanical impact resistance: IK06

Connected power

1. Small Model: 22.5 W
Luminaire luminous flux 3000 K: 2,357 lm (2700 K: 2,284 lm - 2200 K: 1,700 lm)
2. Large Model: 33 W
Luminaire luminous flux 3000 K: 3,700 lm (2700 K: 3,600 lm - 2200 K: 2,900 lm)
Ambient temperature: $t_{a,max} = 45\text{ }^{\circ}\text{C}$
Guaranteed availability of LED modules for 20 years.

Accessories

Available with a ground spike base.



Finish

The finish shown is in La Mer wood and Random rust metal, code +W10.M50.K3. Finish options available in any of the standard shades from the AUBRILAM color chart. Please refer to page 35 of the catalog. Other colors available upon request.

Wood

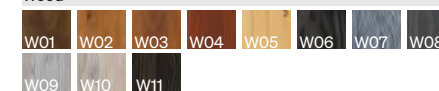

Metal

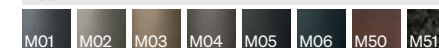

Lighting

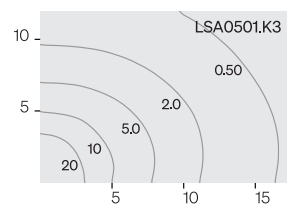
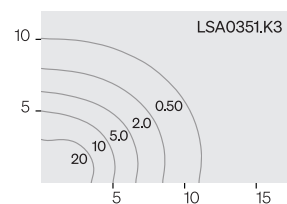

LSA0351 Single
LED 22.5 W • Ø 140 mm • H 3.5 m
LSA0352 Double
2 x LED 22.5 W • Ø 140 mm • H 3.5 m

LSA0401 Single
LED 33 W • Ø 140 mm • H 4 m
LSA0402 Double
SM - LED 22.5 W • Ø 140 mm • H 4 m
LM - LED 33 W • Ø 140 mm • H 4 m

LSA0501 Single
LED 33 W • Ø 140 mm • H 5 m
LSA0502 Double
SM - LED 22.5 W • Ø 140 mm • H 5 m
LM - LED 33 W • Ø 140 mm • H 5 m



Light building element with deflected illumination
 Square light building element made of GL24H certified ACERBOIS GLULAM glued laminated timber, sourced from sustainably managed forests and designed using the HTE process. Wood with four-coat stain finish. Stain durability > 6 years.
 Galvanized steel base with polyester powder coating. Top of pole in cast aluminum with polyester powder coating. CE marked product. CE Certificate of conformity 0679-CPR-0473. Salt air protective coating available upon request.



High-performance optical system with luminaire featuring elliptical asymmetric light distribution. Luminaire made of cast aluminum, aluminum, and stainless steel. Safety glass with anti-reflective coating. Silicone seal.
 DALI control
 Protection class II Ⓜ
 ⚡ Safety symbol
CE Compliance mark
 Degree of protection: IP 66
 Mechanical impact resistance: IK07

Connected power
1. 18.8 W LED Luminaire
 Luminaire luminous flux 3000 K: 2,346 lm
 (2700 K: 2,268 lm - 2200 K: 1,827 lm)
2. 33.5 W LED Luminaire
 Luminaire luminous flux 3000 K: 4,554 lm
 (2700 K: 4,410 lm - 2200 K: 3,540 lm)
 Ambient temperature: $t_{max} = 50\text{ °C}$ (1) • 55 °C (2)
 Guaranteed availability of LED modules for 20 years.



Finish
 The finish shown is in Brume wood and Graphite metal, code +W01.M01.K3. Finish options available in any of the standard shades from the AUBRILAM color chart. Please refer to page 35 of the catalog. Other colors available upon request.

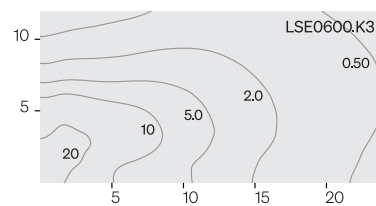
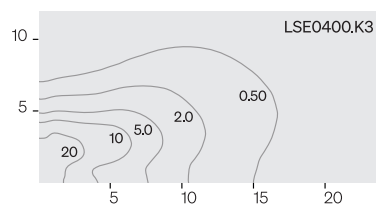
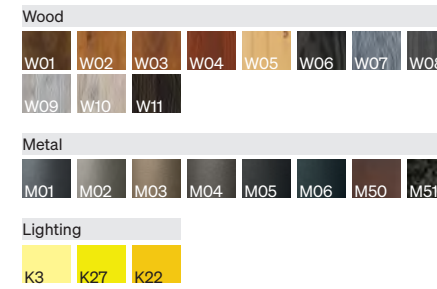

Recommended spacing for accessible pathways:

Sensy	LSE0400.K3	LSE0500.K3
E_m	21 lux	22 lux
E_{min}	13 lux	9 lux
Spacing	13 m	22 m
Width	3 m	3 m

LSE0400 Single
 LED 17.8 W • □ 140 mm • H 4 m
LSE0500 Single
 LED 33.5 W • □ 140 mm • H 5 m
LSE0600 Single
 LED 33.5 W • □ 140 mm • H 6 m

LSE0401 Double
 2 x LED 17.8 W • □ 140 mm • H 4 m
LSE0501 Double
 2 x LED 33.5 W • □ 140 mm • H 5 m
LSE0601 Double
 2 x LED 33.5 W • □ 140 mm • H 6 m

LSE0502 Single Zhaga
 LED 34.5 W • □ 140 mm • H 5 m
LSE0602 Single Zhaga
 LED 34.5 W • □ 140 mm • H 6 m



Light building element with deflected illumination
Square light building element made of GL24H certified ACERBOIS GLULAM glued laminated timber, sourced from sustainably managed forests and designed using the HTE process. Wood with four-coat stain finish. Stain durability > 6 years.
Galvanized steel base with polyester powder coating. Top of pole in cast aluminum with polyester powder coating. CE marked product. CE Certificate of conformity 0679-CPR-0473. Salt air protective coating available upon request.



High-performance optical system with luminaire featuring elliptical asymmetric light distribution. Luminaire made of cast aluminum, aluminum, and stainless steel. Safety glass with anti-reflective coating. Silicone seal.
DALI control
Protection class II Ⓜ
Safety symbol
CE Compliance mark
Degree of protection: IP 66
Mechanical impact resistance: IK07

Connected power
1. 18.8 W LED Luminaire
Luminaire luminous flux 3000 K: 2,346 lm (2700 K: 2,268 lm - 2200 K: 1,827 lm)
2. 33.5 W LED Luminaire
Luminaire luminous flux 3000 K: 4,554 lm (2700 K: 4,410 lm - 2200 K: 3,540 lm)
Ambient temperature: $t_{max} = 50\text{ °C}$ (1) • 55 °C (2)
Guaranteed availability of LED modules for 20 years.



Finish
The finish shown is in Brume wood and Graphite metal, code +W01.M01.K3. Finish options available in any of the standard shades from the AUBRILAM color chart. Please refer to page 35 of the catalog. Other colors available upon request.

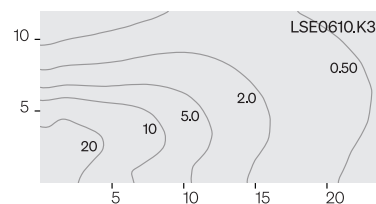
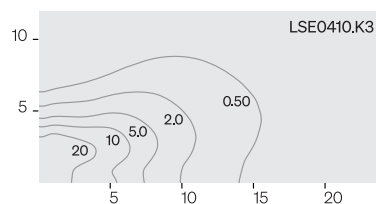
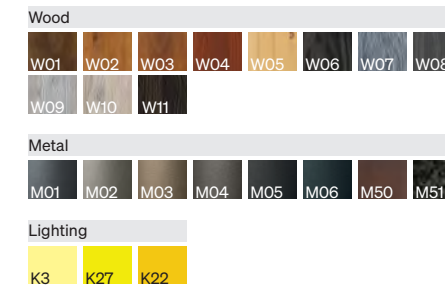

Recommended spacing for accessible pathways:

Sensy	LSE0410.K3	LSE0510.K3
E_m	21 lux	22 lux
E_{min}	13 lux	9 lux
Spacing	13 m	22 m
Width	3 m	3 m

LSE0410 Single
LED 17.8 W • □ 120 mm • H 4 m
LSE0510 Single
LED 33.5 W • □ 120 mm • H 5 m
LSE0610 Single
LED 33.5 W • □ 120 mm • H 6 m

LSE0512 Single Zhaga
LED 34.5 W • □ 120 mm • H 5 m
LSE0612 Single Zhaga
LED 34.5 W • □ 120 mm • H 6 m



Responsible outdoor lighting

Artificial lighting is essential for humans, but it should be as environmentally friendly as possible.

As designers of lighting solutions, we aim to integrate the latest technological advancements that address scientific research on the environmental impact of artificial light.

To achieve this goal, BEGA has developed an approach centered around two key pillars: Dark Sky and BugSaver®.



Dark Sky

Dark Sky luminaires are marked in the catalog with an associated symbol. They efficiently direct their light towards the illuminated surface and emit less than 1% of the light flux in the upper half of the luminaire.

Exact data on the light flux distribution in the upper half, along with declarations regarding BUG ratings per IES TM-15-07 and flux codes per EN 13032-2, are available for each luminaire and should be compared with applicable regional regulations.



BUG Rating According to IES TM-15-07

The system used to evaluate luminaires with photometric data measures the incidence of light in the following areas:

Backlight - Light emitted to the rear of the luminaire

Uplight - Light emitted above the luminaire

Glare - Bright light causing visual discomfort

Values measured in lumens for each zone are rated on a scale from 0 (low) to 5 (high), determining the BUG rating.

Flux Code According to EN 13032-2

This code specifies the percentage of light flux emitted upwards and downwards from the luminaire within a defined spatial angle. Each segment has a value indicating the percentage of light emission.

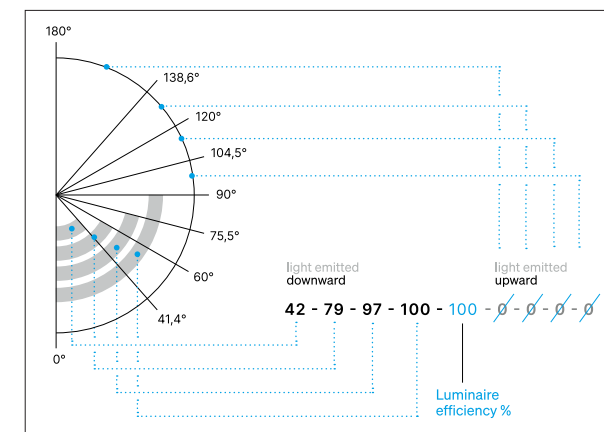

Dark Sky luminaires



To learn more about Dark Sky, visit the BEGA website.

BugSaver® luminaires are marked in the catalog with an associated symbol. BEGA has designed luminaires with BugSaver® technology for efficient lighting in both urban areas and natural environments.

This lighting enhances people's sense of security while minimizing the impact on nocturnal animals. By adjusting the color temperature and light output, they seamlessly blend into the environment at different times of the day, preserving the natural balance. Proper lighting for each location remains a key element in the overall lighting plan.



BEGA technology

To minimize disruption to nocturnal wildlife, BEGA adjusts light color temperature from 3000 Kelvins to Amber (PC-Amber), similar to 1800 Kelvins.

This amber hue significantly reduces blue light emissions, which are most disruptive to nocturnal fauna. Further dimming during nighttime hours enhances this effect.

Careful light diffusion control prevents unnecessary light pollution in the surroundings, significantly reducing disturbance to local flora and fauna. Lighting control is managed through BEGA BugSaver® devices or DALI lighting management systems.

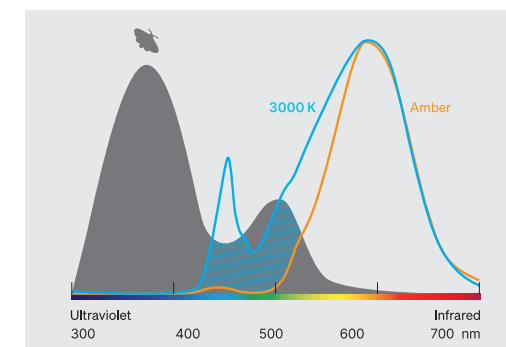

Comparison of how insects perceive colors and LED spectra - LEDs with PC-Amber technology significantly reduce blue light emissions around 440 nm.

Nighttime adjustment

By carefully managing color temperature and light intensity during nighttime hours, it is possible to reduce the impact on the environment and the life of light-sensitive insects, without compromising user safety.

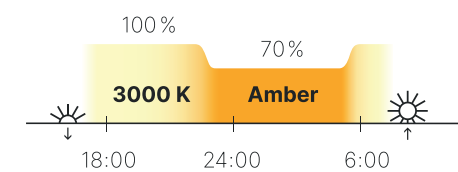

Color temperature and light power management

Luminaire control is managed either through the BEGA BugSaver® control interface for a straightforward, standalone solution, or via DALI DT8 integrated into a lighting management system provided by the client.



BEGA BugSaver® control interface

The BEGA BugSaver® control interface enables adjustment of color temperature while reducing power consumption. Control can be activated through phase control or automatically using the virtual midnight calculation. Each interface can independently manage up to nine luminaires, without requiring additional components.

BugSaver® luminaires



To learn more about BugSaver®, visit the BEGA website.

Control solutions

DALI dimming solutions

There are straightforward solutions for dimming DALI devices. The dimming module integrates the DALI bus power supply and allows for dimming of up to nine DALI devices.

It operates in two modes, switchable via a module switch:

- Mode 1: Reduces power through phase control.
- Mode 2: Reduces power using virtual midnight calculations.

The module's compact size allows for installation inside the luminaire or in the connection box.



Zhaga lighting management

Standardized interface for detection and communication modules.

The Zhaga Book 18 integrates harmonized specifications from the Zhaga consortium with D4i specifications from the DALI Alliance, creating a cutting-edge system that anticipates future advancements in digital networking and sensor technology, an ever-evolving sector. A Plug-and-Play connectivity system enables easy addition or updating of communication modules and sensors.

Effortlessly manage street and pathway lighting

Equipping luminaires with the Zhaga Book 18 interface is an investment in the future: radio-based management and control are facilitated through the use of communication modules. This setup allows for easy modernization and future replacements.

Using luminaires with the Zhaga interface provides a practical and swift solution for implementing street and pathway lighting management, such as online via the Cloud.

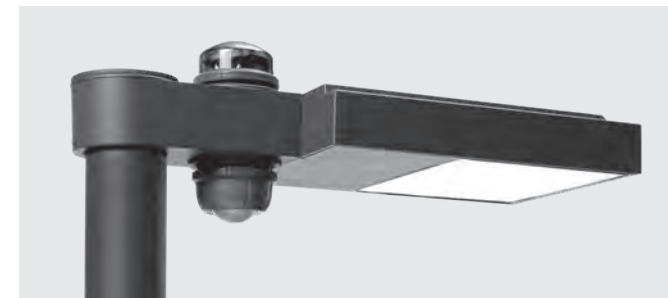

Communication module

Communication between various luminaires and/or a higher-level system is wireless. BEGA has developed the Zhaga Air Connector to make all luminaires IoT-compatible without the need for onsite control lines or internet access.

Each luminaire equipped with a Zhaga Book 18 interface can seamlessly integrate into the BEGA Connect Cloud using the Zhaga Air Connector, making it truly effortless! It is also possible to use other Zhaga controllers available on the market.

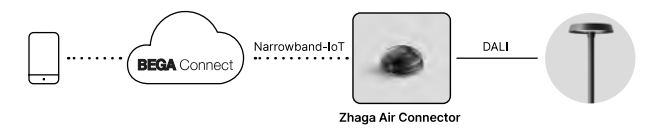

Each Zhaga Air Connector serves as a standalone endpoint within the BEGA Connect Cloud. The platform enables centralized control of all luminaires within a unified system, ensuring consistent automation rules.

Luminaires available with Zhaga technology



Learn more about Zhaga technology, visit the BEGA website.



Pole on base plate	Height	Section	Visible base height
MSK1350	3.5 m	□ 145-140 mm	0.45 m
MSK1400	4 m	□ 145-140 mm	0.45 m
MSK1500	5 m	□ 145-140 mm	0.45 m

Rectangular support

The solid wood nested elements are made of sustainably sourced Accoya® acetylated wood. Four-coat stain finish. Stain durability > 10 years.

The flush and rectangular base is made of galvanized steel with a polyester powder coating. The brackets and pole top are constructed from electrogalvanized steel, also with a polyester powder coating. Salt air protective coating available upon request.

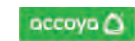

Finish

The finish shown is in Brume wood and Graphite metal, code **+W01.M01**. Finish options available in any of the standard shades from the AUBRILAM color chart. Please refer to page 35 of the catalog. Other colors available upon request.

Wood

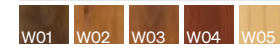

Métal

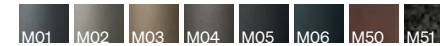



Pole on base plate	Pole with ground spike base	Height	Section	Visible base height
MMO1350	MMO3350	3.5 m	□ 120 mm	1 m
MMO1400	MMO3400	4 m	□ 120 mm	1 m
MMO1500	MMO3500	5 m	□ 120 mm	1 m
MMO1501	MMO3501	5 m	□ 140 mm	1.20 m
MMO1600	MMO3600	6 m	□ 140 mm	1.20 m
MMO1601	MMO3601	6 m	□ 160 mm	1.20 m

Square support

Square section pole made of GL24H certified ACERBOIS GLULAM glued laminated timber, sourced from sustainably managed and certified forests (PEFC).
 Designed using the HTE (high outdoor durability) process: the pole is constructed from four glulam beams using a double cross-lamination process, ensuring high outdoor durability of the product.
 Structural lifespan: 25 years.
 Four-coat stain finish. Stain durability > 6 years.
 The flush and square base and the pole top are made of galvanized steel with a polyester powder coating. CE marked product: CE Certificate of conformity 0679-CPR-0473.
 Salt air protective coating available upon request.



Finish

The finish shown is in Brume wood and Graphite metal, code +.W01.M01. Finish options available in any of the standard shades from the AUBRILAM color chart. Please refer to page 35 of the catalog. Other colors available upon request.

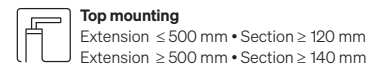
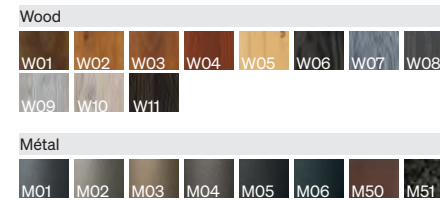



Pole on base plate	Pole with ground spike base	Height	Section	Visible base height
MSI1400	MSI3400	4 m	□ 120-76 mm	1 m
MSI1500	MSI3500	5 m	□ 120-76 mm	1 m
MSI1501	MSI3501	5 m	□ 140-76 mm	1.20 m
MSI1600	MSI3600	6 m	□ 140-76 mm	1.20 m
MSI1601	MSI3601	6 m	□ 160-120 mm	1.20 m
MSI1700	MSI3700	7 m	□ 160-120 mm	1.20 m
MSI1800	MSI3800	8 m	□ 200-140 mm	1.50 m
MSI1900	MSI3900	9 m	□ 200-140 mm	1.50 m
MSI1901	MSI3901	9 m	□ 220-140 mm	1.50 m
MSI1100	MSI3100	10 m	□ 220-140 mm	1.50 m
MSI1101	MSI3101	10 m	□ 250-140 mm	1.50 m
MSI1120	MSI3120	12 m	□ 250-140 mm	1.50 m
MSI1121	MSI3121	12 m	□ 300-160 mm	1.50 m
MSI1140	MSI3140	14 m	□ 300-160 mm	1.50 m
MSI1160	MSI3160	16 m	□ 350-160 mm	1.50 m

Square conical support

Square conical section pole made of GL24H certified ACERBOIS GLULAM glued laminated timber, sourced from sustainably managed and certified forests (PEFC). Designed using the HTE (high outdoor durability) process: the pole is constructed from four glulam beams using a double cross-lamination process, ensuring high outdoor durability of the product. Structural lifespan: 25 years. Four-coat stain finish. Stain durability > 6 years. The flush and square base and the pole top are made of galvanized steel with a polyester powder coating. CE marked product: CE Certificate of conformity 0679-CPR-0473. Salt air protective coating available upon request.



Finish

The finish shown is in Brume wood and Graphite metal, code +.W01.M01. Finish options available in any of the standard shades from the AUBRILAM color chart. Please refer to page 35 of the catalog. Other colors available upon request.

Wood



Métal

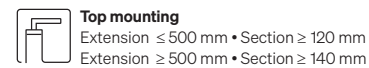
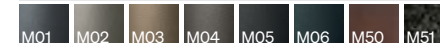



Pole on base plate	Pole with ground spike base	Height	Section	Visible base height
MSU1300	MSU3300	3 m	Ø 115 mm	1 m
MSU1400	MSU3400	4 m	Ø 115 mm	1 m
MSU1401	MSU3401	4 m	Ø 140 mm	1.10 m
MSU1500	MSU3500	5 m	Ø 115 mm	1 m
MSU1501	MSU3501	5 m	Ø 140 mm	1.10 m
MSU1600	MSU3600	6 m	Ø 140 mm	1.10 m
MSU1601	MSU3601	6 m	Ø 168 mm	1.20 m

Round support

Round section pole made of GL24H certified ACERBOIS GLULAM glued laminated timber, sourced from sustainably managed and certified forests (PEFC). Designed using the HTE (high outdoor durability) process: the pole is constructed from four glulam beams using a double cross-lamination process, ensuring high outdoor durability of the product. Structural lifespan: 25 years. Four-coat stain finish. Stain durability > 6 years. The flush and round base and the pole top are made of galvanized steel with a polyester powder coating. CE marked product: CE Certificate of conformity 0679-CPR-0473. Salt air protective coating available upon request.



Finish

The finish shown is in Brume wood and Graphite metal, code **+.W01.M01**. Finish options available in any of the standard shades from the AUBRILAM color chart. Please refer to page 35 of the catalog. Other colors available upon request.

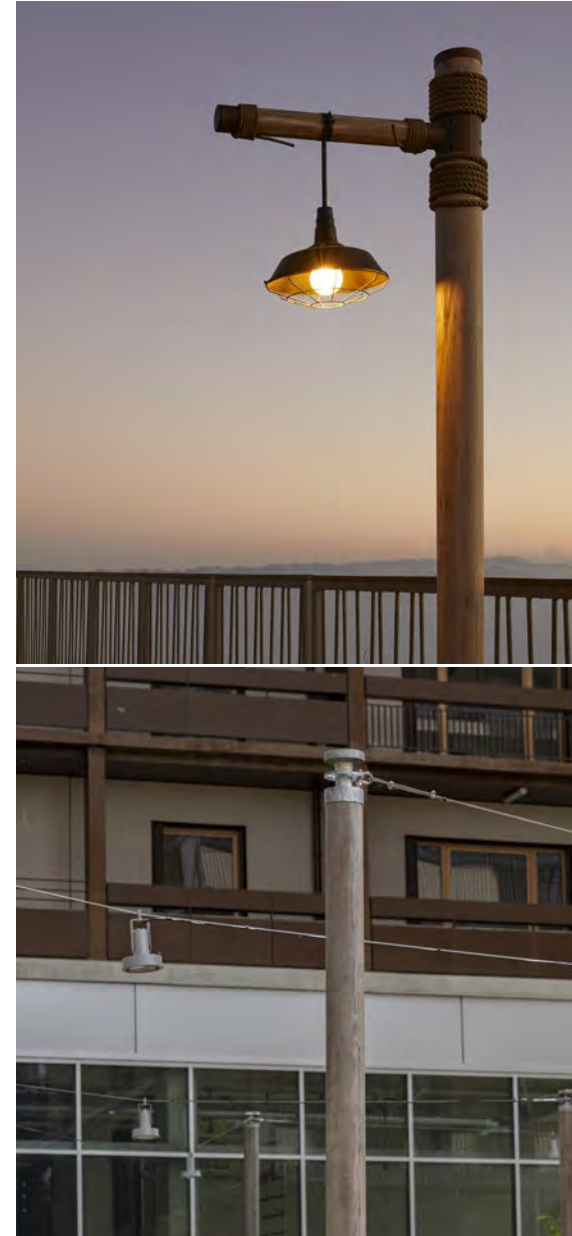
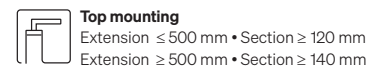
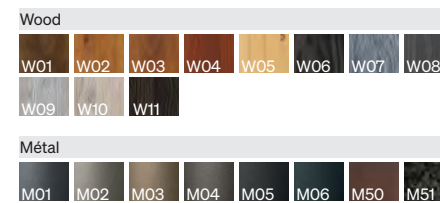



Pole on base plate	Pole with ground spike base	Height	Section	Visible base height
MDO1300	MDO3300	3 m	Ø 115-76 mm	1 m
MDO1350	MDO3350	3.5 m	Ø 115-76 mm	1 m
MDO1351	MDO3351	3.5 m	Ø 140-76 mm	1 m
MDO1400	MDO3400	4 m	Ø 115-76 mm	1 m
MDO1401	MDO3401	4 m	Ø 140-76 mm	1.10 m
MDO1500	MDO3500	5 m	Ø 115-76 mm	1 m
MDO1501	MDO3501	5 m	Ø 140-76 mm	1.10 m
MDO1502	MDO3502	5 m	Ø 168-120 mm	1.20 m
MDO1600	MDO3600	6 m	Ø 140-76 mm	1.10 m
MDO1601	MDO3601	6 m	Ø 168-120 mm	1.20 m
MDO1700	MDO3700	7 m	Ø 168-120 mm	1.20 m
MDO1701	MDO3701	7 m	Ø 194-140 mm	1.20 m
MDO1800	MDO3800	8 m	Ø 194-140 mm	1.20 m
MDO1801	MDO3801	8 m	Ø 220-140 mm	1.35 m
MDO1900	MDO3900	9 m	Ø 194-140 mm	1.20 m
MDO1901	MDO3901	9 m	Ø 220-140 mm	1.35 m
MDO1100	MDO3100	10 m	Ø 220-140 mm	1.35 m
MDO1101	MDO3101	10 m	Ø 245-140 mm	1.50 m
MDO1120	MDO3120	12 m	Ø 245-140 mm	1.50 m
MDO1121	MDO3121	12 m	Ø 275-140 mm	1.50 m
MDO1140	MDO3140	14 m	Ø 275-140 mm	1.50 m

Round conical support

Round conical section pole made from GL24H certified ACERBOIS GLULAM glued laminated timber, sourced from sustainably managed and certified forests (PEFC). Designed using the HTE (high outdoor durability) process: the pole is constructed from four glulam beams using a double cross-lamination process, ensuring high outdoor durability of the product. Structural lifespan: 25 years. Four-coat stain finish. Stain durability > 6 years. The flush and round base and the pole top are made of galvanized steel with a polyester powder coating. CE marked product: CE Certificate of conformity 0679-CPR-0473. Salt air protective coating available upon request.



Finish

The finish shown is in Brume wood and Graphite metal, code +.W01.M01. Finish options available in any of the standard shades from the AUBRILAM color chart. Please refer to page 35 of the catalog. Other colors available upon request.

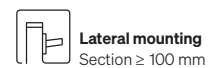
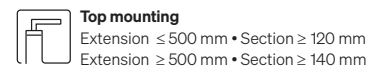
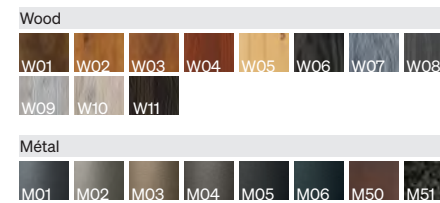



Pole on base plate	Height	Section	Visible base height
MST1120	12 m	□ 250-140 mm	1.50 m
MST1121	12 m	□ 300-160 mm	1.50 m
MST1140	14 m	□ 300-160 mm	1.50 m
MST1160	16 m	□ 350-160 mm	1.50 m

Double square conical support

Double pole with square conical section made of GL24H certified ACERBOIS GLULAM glued laminated timber, sourced from sustainably managed and certified forests (PEFC).
 Designed using the HTE (high outdoor durability) process: the pole is constructed from four glulam beams using a double cross-lamination process, ensuring high outdoor durability of the product.
 Structural lifespan: 25 years.
 Four-coat stain finish. Stain durability > 6 years.
 The flush and square base and the pole top are made of galvanized steel with a polyester powder coating. Salt air protective coating available upon request.



Finish

The finish shown is in Brume wood and Graphite metal, code +.W01.M01. Finish options available in any of the standard shades from the AUBRILAM color chart. Please refer to page 35 of the catalog. Other colors available upon request.

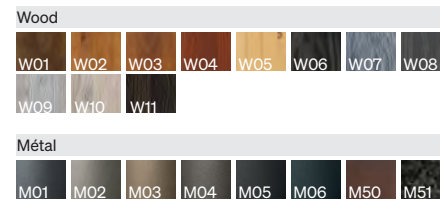



Pole on base plate	Height	Section	Visible base height
MCA1120	12 m	Ø 245-140 mm	1.50 m
MCA1121	12 m	Ø 275-140 mm	1.50 m
MCA1140	14 m	Ø 275-140 mm	1.50 m

Double round conical support

Double pole with round conical section made of GL24H certified ACERBOIS GLULAM glued laminated timber, sourced from sustainably managed and certified forests (PEFC). Designed using the HTE (high outdoor durability) process: the pole is constructed from four glulam beams using a double cross-lamination process, ensuring high outdoor durability of the product.
 Structural lifespan: 25 years.
 Four-coat stain finish. Stain durability > 6 years.
 The flush and round base and the pole top are made of galvanized steel with a polyester powder coating. Salt air protective coating available upon request.



Finish

The finish shown is in Brume wood and Graphite metal, code +.W01.M01. Finish options available in any of the standard shades from the AUBRILAM color chart. Please refer to page 35 of the catalog. Other colors available upon request.

Wood

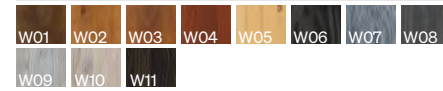

Métal

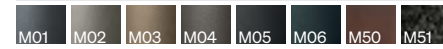



Pole on base plate	Height	Section	Visible base height
MIT1800	8 m	Ø 194-140 mm	1.20 m
MIT1100	10 m	Ø 220-140 mm	1.35 m
MIT1120	12 m	Ø 245-140 mm	1.50 m

Round conical support

Inclined pole with round conical section made of GL24H certified ACERBOIS GLULAM glued laminated timber, sourced from sustainably managed and certified forests (PEFC). Designed using the HTE (high outdoor durability) process: the pole is constructed from four glulam beams using a double cross-lamination process, ensuring high outdoor durability of the product. Structural lifespan: 25 years. Four-coat stain finish. Stain durability > 6 years. The flush and round base and the pole top are made of galvanized steel with a polyester powder coating. CE marked product: CE Certificate of conformity 0679-CPR-0473. Salt air protective coating available upon request.



Finish

The finish shown is in Brume wood and Graphite metal, code +.W01.M01. Finish options available in any of the standard shades from the AUBRILAM color chart. Please refer to page 35 of the catalog. Other colors available upon request.

Wood

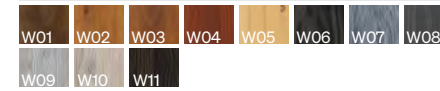

Métal

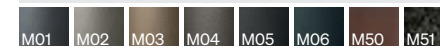



Linea

Materials
 Mechanically welded galvanized steel side-mounted bracket, polyester powder coating. Compatible with a minimum top section of 120 mm.

DCR2037 Single on round pole
 H 150 mm • Outreach 500 mm
DCR2039 Single on square pole
 H 150 mm • Outreach 500 mm

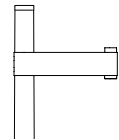

DCR2038 Double on round pole
 H 150 mm • Outreach 2 x 500 mm
DCR2040 Double on square pole
 H 150 mm • Outreach 2 x 500 mm

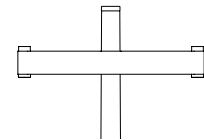

Axis

Materials
 Mechanically welded galvanized steel bracket, polyester powder coating. Compatible with a minimum top section of 140 mm.

DCR2013 Axis 1 single
 H 650 mm • Outreach 632 mm

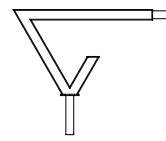

DCR2014 Axis 2 single
 H 730 mm • Outreach 919 mm

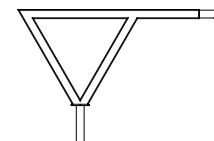

DCR2015 Axis 2 double
 H 730 mm • Outreach 2 x 919 mm

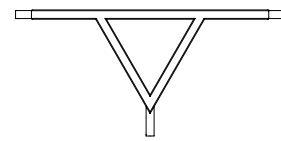

DCR2016 Axis 3 double
 H 650 mm • Outreach 1,792 mm

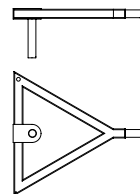

DCR2017 Axis 4 single
 H 82 mm • Outreach 724 mm

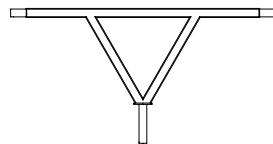

DCR2018 Axis 4 side
 H 70 mm • Outreach 789 mm

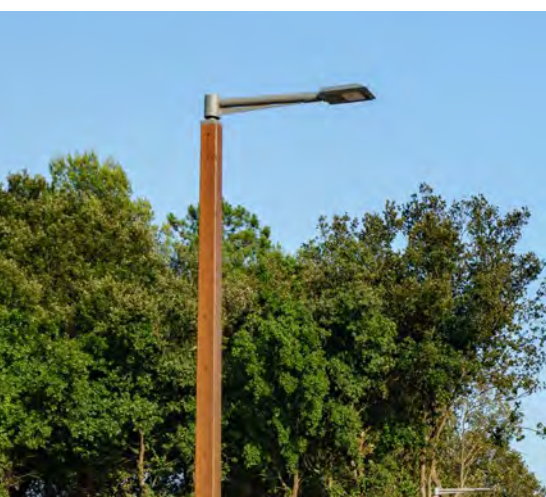
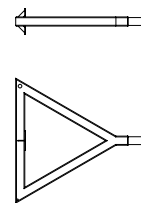

Api

Materials
 Mechanically welded galvanized steel bracket and side-mounted bracket, polyester powder coating. Compatible with a minimum top section of 140 mm.

DCR2002 Single
 Tilt 2° • H 187 mm
 Outreach 787 mm

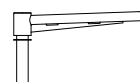

DCR2003 Double
 Tilt 2° • H 187 mm
 Outreach 2 x 787 mm

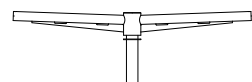

DCR2004 Side
 Tilt 2° • H 250 mm
 Outreach 750 mm



Solis

Materials
 Mechanically welded galvanized steel bracket, polyester powder coating. Compatible with a minimum top section of 120 mm for an outreach of 500 mm, and with a minimum top section of 140 mm for an outreach of 1 m.

DCR2005 Solis 1 light
 Tilt 5° • H 144 mm
 Outreach 500 mm
DCR2009 Solis 1 light
 Tilt 5° • H 144 mm
 Outreach 1 m

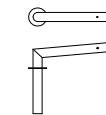

DCR2006 Solis 2 lights
 Tilt 5° • H 144 mm
 Outreach 500 mm
DCR2010 Solis 2 lights
 Tilt 5° • H 144 mm
 Outreach 1 m

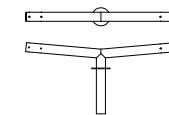

DCR2007 Solis 3 lights
 Tilt 5° • H 144 mm
 Outreach 500 mm
DCR2011 Solis 3 lights
 Tilt 5° • H 144 mm
 Outreach 1 m

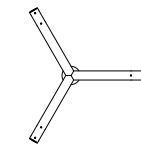

DCR2008 Solis 4 lights
 Tilt 5° • H 144 mm
 Outreach 500 mm
DCR2012 Solis 4 lights
 Tilt 5° • H 144 mm
 Outreach 1 m

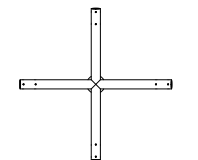

Bussy

Materials
 Cast aluminum extension, with polyester powder coating. Arms and tie rod in aluminum tube, with polyester powder coating. Compatible only with a round section pole, minimum top diameter 120 mm.

DCR2019 Single Ø 120 mm
 Tilt 5° • H 1.20 m
 Outreach 1.51 m

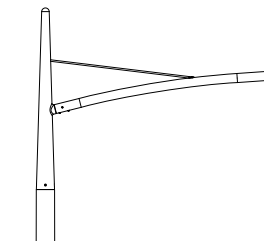

DCR2020 Double Ø 120 mm
 Tilt 5° • H 1.20 m
 Outreach 2 x 1.51 m

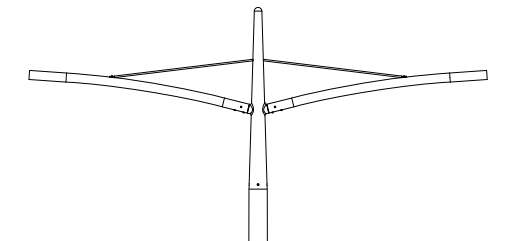

Catelam

Materials
 Cast aluminum extension, with polyester powder coating. Arms and tie rod in mechanically welded galvanized steel. Adjustable tie rod with turnbuckle. Compatible only with a round section pole, minimum top diameter 140 mm or 168 mm.

DCR2024 Single Ø 140 mm
 Tilt 0.5° • H 1 m
 Outreach 1 m
DCR2025 Single Ø 168 mm
 Tilt 0.5° • H 1 m
 Outreach 1 m

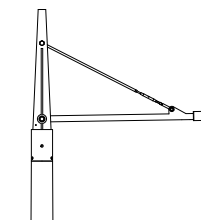

DCR2026 Double Ø 140 mm
 Tilt 0.5° • H 1 m
 Outreach 2 x 1 m
DCR2027 Double Ø 168 mm
 Tilt 0.5° • H 1 m
 Outreach 2 x 1 m

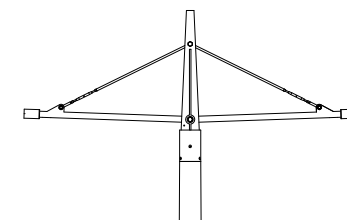

DCR2028 Side
 Tilt 0.5° • H 600 mm
 Outreach 1.18 m

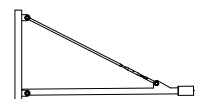



Elea

Materials
 Brackets and side-mounted brackets in cast aluminum, polyester powder coating. Compatible with a minimum top section of 140 mm.

DCR2041 Single
 H 413 mm • Outreach 1,030 mm

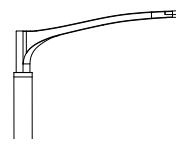

DCR2042 Double
 H 413 mm • Outreach 2 × 1,030 mm

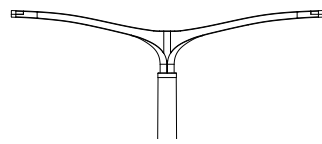

DCR2043 Wall-mounted
 H 410 mm • Outreach 1,131 mm



The end caps serve to connect the pole support and the luminaire. Each of our poles comes equipped with one or more end caps, tailored in diameter, length, and placement to fit the chosen lantern or projector type for the project.

These end caps can be positioned at the top, on the side directly attached to the pole, or at the end of the bracket. The lateral end cap may have a slight tilt. Our standard lateral end cap on the pole is the Ceno end cap, crafted from cast aluminum, with a diameter of 60 mm, length of 100 mm, and a 5° tilt.

Our brackets come standard with an end cap of 60 mm diameter and 100 mm length. When a different type of end cap is required, we study the appropriate solution.

The end cap diameter is determined based on the lantern so that it fits over the end cap. Please note, for certain lantern models, their end cap may fit inside our end cap. In such cases, we can study a specific end cap upon request.



Râ

Materials
 Cast aluminum side-mounted bracket and adapter, with polyester powder coating. Compatible with a top section diameter of 115 mm, 140 mm, and 168 mm for round poles. Compatible with a minimum top section of 120 mm for square poles.

DCR2031 Single
 H 900 mm • Outreach 484 mm

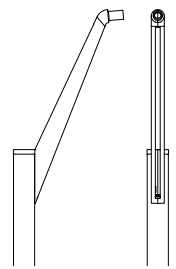

DCR2032 Double
 H 900 mm • Outreach 2 × 484 mm

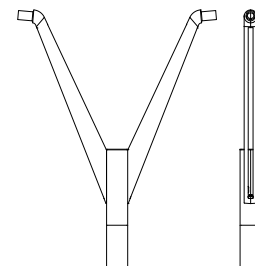

DCR2033 Adapter pole Ø 140 mm
DCR2034 Adapter pole Ø 168 mm
DCR2035 Adapter for projector

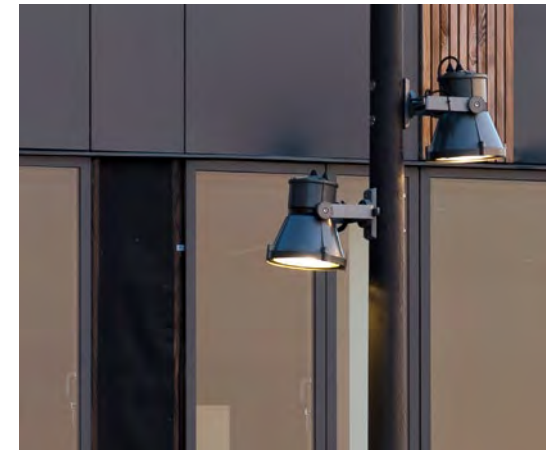
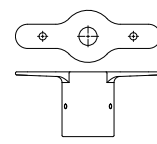

Ceno

DCR2036 Projector bracket
 Made of cast aluminum with polyester powder coating, the projector bracket is fixed and pivots on its base. It is compatible with a minimum top section diameter of 120 mm for round poles and 100 mm for square poles.

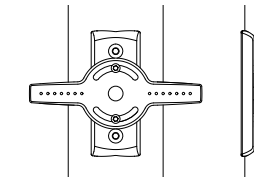

DCR2001 Side end cap
 Made of cast aluminum with polyester powder coating. Compatible with a minimum top section diameter of 120 mm for round poles and 100 mm for square poles. Tilt 5° • Ø 60 mm • Length 100 mm

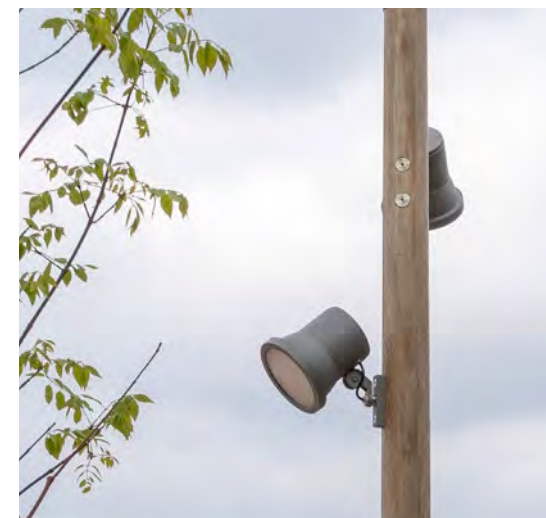
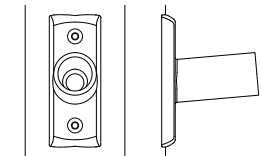

DCR2000 Fixture mount for projector with G1/2 thread
 Fixture mount for cast aluminum projector, with polyester powder coating. 140 × 30 mm



Catelam

Materials
 Cast aluminum extension, with polyester powder coating. Compatible with a minimum top section of 140 mm for round poles.

DCR2029 Extension Ø 140 mm
 H 1 m
DCR2030 Extension Ø 168 mm
 H 1 m

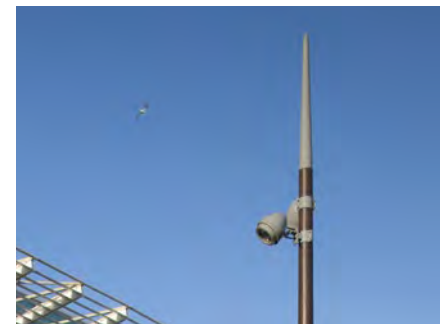

Bussy

Materials
 Cast aluminum cylindrical-conical extension, with polyester powder coating. Compatible with a top section diameter of 100 mm, 120 mm, and 140 mm for round poles.

DCR2021 Extension Ø 100 mm
 H 1,10 m
DCR2022 Extension Ø 120 mm
 H 1,20 m
DCR2023 Extension Ø 140 mm
 H 1,535 m





Mounting banners

Mounting banners on a pole is accomplished using rings equipped with welded arms or mounting points. Banners can be secured using either two arms (through threading or with an elastic cord) or with one arm and a fixed point at the bottom.

It is essential to conduct a strength analysis to confirm the pole diameter or section and the dimensions of the banners to be installed. These calculations factor in wind conditions, terrain roughness, and the properties of the chosen fabric.

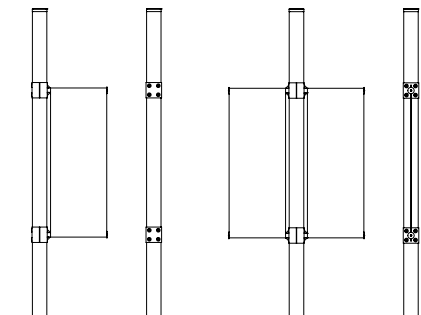

Rings for securing cables and decorative lights

Rings for securing cables and decorative lights on glulam poles. This system allows for creating sets of multiple poles with heights and spacing defined in the project layout.

A strength analysis is necessary to verify pole diameter based on wind conditions, terrain roughness, and the equipment to be hung, such as decorative lights, suspended luminaires, stretched sails, etc.

Materials

Galvanized steel, with polyester powder coating. Designed exclusively for cylindrical poles.

DAC2003 Lateral ring Ø 140 mm
DAC2004 Lateral ring Ø 168 mm
DAC2005 Lateral ring Ø 194 mm



DAC2000 Top ring Ø 140 mm
DAC2001 Top ring Ø 168 mm
DAC2002 Top ring Ø 194 mm

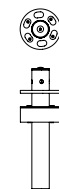





All offers and services provided by AUBRILAM on behalf of companies are done so exclusively in accordance with our Terms and Conditions of Sale, which can be accessed at www.aubrilam.com.

Subject to technical or design modifications. The colors in the catalog may vary due to the printing process.

© AUBRILAM - 2024

Catalog no. 16 published by AUBRILAM

83 rue Fontglève
63000 Clermont-Ferrand
France
+33 4 73 31 86 86

Design
AUBRILAM

Photos and images

Agence Imaginium - Oussama Rhaleb • Anna Szonyi • BEGA • Cadsign • Design de Lux - Vincent Muracciole • Gilles Coutelier • Jaap Lotstra • Jean-Michel Gueugnot • Jeudi Wang • La Cime • Ludovic Combe • Marshalls • Michel Denancé • Momentary Awe Photography • Nathan Hausermann • Saguez & Partners • Sergio Grazia • Shutterstock • Tom Niven • Vincent Spinard • Woodhouse • Xavier Boymond.

Catalog printed in Limoges in August 2024 at IMPRIMATUR printing, certified with the Imprim'vert label.



AUBRILAM
BEGA Group

83 rue Fontgèze
63000 Clermont-Ferrand
France
+33 4 73 31 86 86
www.aubrilam.com



GAA14576