

## Foreword

Thank you for choosing Hongqi EHS7!

European version of Hongqi EHS7 has passed the EU vehicle type approval.

Hongqi EHS7 is equipped with various luxury equipment and advanced technologies. In order to make full use of these equipment and technologies in your vehicle life in the future, it is recommended that you read this manual carefully so that you can quickly and comprehensively understand Hongqi EHS7.

This manual provides detailed instructions on safe driving, vehicle maintenance, and emergency countermeasures in addition to introducing how to use the vehicle, aiming to enable you to use the vehicle safely and comfortably, while maximizing the value of the vehicle.

This manual is based on the product's conditions at the time of publication, subsequent product changes will be revised at the time of reprinting and the revisions will be made without notice. Thanks for understanding.

For any further questions about the vehicle or if you feel the information provided in the accompanying documents is insufficient, please consult an authorized FAW Hongqi dealer, and we will be happy to help you!

You can view or download the latest version of the Owner's Manual from the Hongqi official website. Before using the vehicle, it is recommended that you read the manual carefully.

Have a nice drive!

China FAW Group Import and Export Co., Ltd

## Instructions for use

The user must hold a driving license before driving the vehicle on the road. This manual is intended for such users.

As a general manual, this manual is applicable to multiple models of EHS7. Some of the equipment described in the manual may not be installed on your vehicle.

\* in this manual indicates that the configurations and functions may vary depending on model.

This manual only describes the use of vehicle functions. For specific configuration information of vehicle, please refer to the relevant sales materials or consult the dealer you purchased the vehicle.

The pictures in this manual are for reference only to help you understand the vehicle more intuitively, which may be slightly different from your vehicle. Please refer to the real vehicle configurations.

All specifications provided in this manual are up-to-date when it goes to press. However, due to ongoing modifications and improvements by FAW, the equipment and performance of the follow-up models may vary. Thus, the content of this manual is subject to change without notice. Please do not compare the owner's manual of other versions with the equipment and performance of your vehicle, or require for retrofitting based on the difference between the two. If you have any questions about your vehicle or this owner's manual, please consult an authorized FAW Hongqi dealer.

# Table of contents

	Index of figures	Search by figures
1	Instructions before driving	Always read safety instructions
2	Preparation before driving	Inspection and preparation before driving
3	Getting on/off the vehicle	Using doors and trunk
4	Comfort adjustment	Adjustment before driving and using interior equipment
5	In-vehicle infotainment system	Operate in-vehicle infotainment system
6	Driving the vehicle	Necessary operations and recommendations during driving
7	Parking assist	Auxiliary functions when parking
8	Parking the vehicle	Safe operations when parking
9	Fault and emergency handling	Countermeasures in case of a fault or an emergency
10	Maintenance and specifications	Detailed information on maintenance procedures and specifications
	Other information	List of abbreviations and other information contained in this manual

**1** Instructions before driving

**1-1. Instructions for safe use**

Safe driving ..... 24  
 Seat belt ..... 26  
 Airbag ..... 32  
 Child safety information ..... 44  
 Child restraint system .... 45  
 Installation of child restraint system ..... 53  
 High voltage safety ..... 56

**1-2. Warning lamps and indicator lamps**

Indicator lamp ..... 59  
 Warning lamp ..... 61

**1-3. IMMO system/anti-theft system**

Immobilizer system ..... 68  
 Body anti-theft system .... 69

**2** Preparation before driving

**2-1. Vehicle inspection**

Inspection before driving ..... 72

**2-2. Driving in winter**

Driving essentials in winter ..... 73

**2-3. Remote control**

Hongqi Zhilian APP ..... 75

**2-4. Charging/discharging**

Opening charging port cover ..... 78  
 Methods and steps of charging/discharging ... 81  
 Display and setting of charging ..... 92  
 Charging/discharging troubleshooting ..... 96

**3** Getting on/off the vehicle

**3-1. Key information**

Key ..... 102

**3-2. Opening, closing and locking doors and back door**

Door ..... 105  
 Back door ..... 111  
 PEPS ..... 117

**3-3. Loading**

Goods and luggage ..... 122

## 4 Comfort adjustment

### 4-1. Seats

Front seat .....	126
Rear seat .....	128
Rear headrest .....	131
Seat memory .....	133
Seat temperature control* .....	135
Seat massage function* .....	137

### 4-2. Steering wheel and rearview mirror

Steering wheel .....	138
Anti-glare interior rearview mirror .....	141
Exterior rearview mirror .....	142

### 4-3. Windows

Power window .....	146
--------------------	-----

### 4-4. A/C system

Automatic A/C system .....	148
Rear windshield heating .....	162

### 4-5. Interior power supply

On-board wireless charging .....	163
Power outlet .....	165

### 4-6. Interior lamp

Using interior lamp .....	167
---------------------------	-----

### 4-7. Storage compartments

Storage compartments list .....	170
---------------------------------	-----

### 4-8. Other equipment

Using other equipment .....	177
-----------------------------	-----

## 5 In-vehicle infotainment system

### 5-1. Basic operation

Multimedia display .....	182
USB data interface .....	186

### 5-2. Using in-vehicle infotainment system

Setting* .....	188
Navigation* .....	199
Entertainment* .....	203
Extended application* ..	204

1

2

3

4

5

6

7

8

9

10

**5-3. Using hands-free system**

Hands-free system ..... 206

**5-4. Using voice recognition**

Voice recognition ..... 209

**6 Driving the vehicle**

**6-1. Instrument information**

Instrument cluster ..... 212

Head up display\* ..... 216

**6-2. Driving specifications**

Driving the vehicle ..... 219

Vehicle power supply mode ..... 226

Gearshift control ..... 228

Driving mode ..... 232

Air suspension\* ..... 236

**6-3. Operating lamps and wipers**

Headlamp switch ..... 240

Intelligent high beam control (IHC)\* ..... 244

Turn signal lamp control lever ..... 247

Fog lamp switch ..... 248

Front windshield wiper & washer ..... 249

Rear windshield wiper & washer ..... 253

**6-4. Using driver assistance system**

Adaptive cruise control (ACC)\* ..... 255

Super adaptive cruise control (SACC )\* ..... 264

Tire pressure monitoring system (TPMS) ..... 271

Lane keeping assist (LDW/LKA)\* ..... 273

Driver status monitor (DSM)\* ..... 276

Forward collision warning (FCW ) \* ..... 279

Autonomous emergency braking (AEB)\* ..... 282

Blind spot detection (BSD)\* ..... 286

Emergency steering assistance (ESA)\* ..... 293

Intelligent speed limit warning system (ISA)\* ..... 296

Driver controlled lane change (DCLC)\* ..... 298

Reverse tracking\* ..... 305

Driver assistance system ..... 309

## 7 Parking assist

### 7-1. Parking control

Front and rear parking radar .....	316
Around view monitor (AVM) .....	321
Auto parking assist (APA)* .....	327
Rear automatic emergency braking (RAEB)* .....	337

## 8 Parking the vehicle

### 8-1. Parking assist

Electronic parking brake (EPB) .....	340
AUTO HOLD .....	342

### 8-2. Get-off

Door opening warning* .....	344
-----------------------------	-----

## 9 Fault and emergency handling

### 9-1. Important information

Hazard warning lamp ....	348
SOS alarm .....	349

### 9-2. Countermeasures in case of an emergency

If the vehicle needs to be towed .....	350
If the vehicle is found to be abnormal .....	355
If you have a flat tire .....	356
If the power system cannot start .....	357
If the key is lost .....	358
If the key fails to work normally .....	359
If 12 V battery power is low .....	361
If your vehicle overheats .....	365
If an electrical fire occurs .....	367
If vehicle gets trapped .....	368
If driving on water-logged road .....	370
If you have a burst tire .....	371
Emergency opening of back door .....	372

1

2

3

4

5

6

7

8

9

10

**10 Maintenance and specifications**

**10-1. Service and maintenance**

- Cleaning and protecting exterior trims of vehicle ..... 376
- Cleaning and protecting interior trims of vehicle ..... 378

**10-2. Maintenance**

- Precautions for maintenance ..... 382

**10-3. Maintenance by yourself**

- Precautions for maintenance by yourself ..... 385
- Front compartment cover ..... 388
- Front compartment ..... 389
- 12 V battery ..... 395
- Tire ..... 400
- Tire pressure ..... 403
- Wheel ..... 405
- A/C filter ..... 407
- Fragrance box\* ..... 409
- Replacing key battery ... 410
- Checking and replacing fuse ..... 412
- Power battery ..... 414

**10-4. Specifications**

- Maintenance data ..... 418

**Other information**

- List of abbreviations.....436**

- Privacy notice ..... 439**

- Event data recorder ..... 440**



1

2

3

4

5

6

7

8

9

10

Front compartment cover

P.388

Front windshield wiper P.249

Exterior rearview mirror P.142

Side turn signal lamp P.247

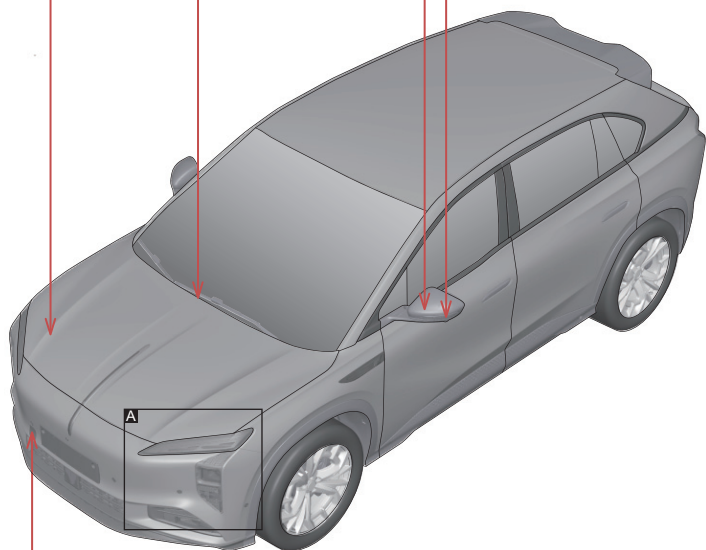

Towing eye hole cover

P.352

Daytime running lamp P.240

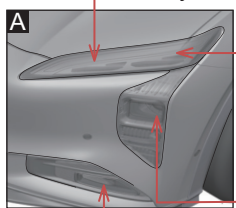

Front turn signal lamp P.247

Front position lamp P.240

Low beam lamp P.240

High beam lamp P.240

Front fog lamp P.248

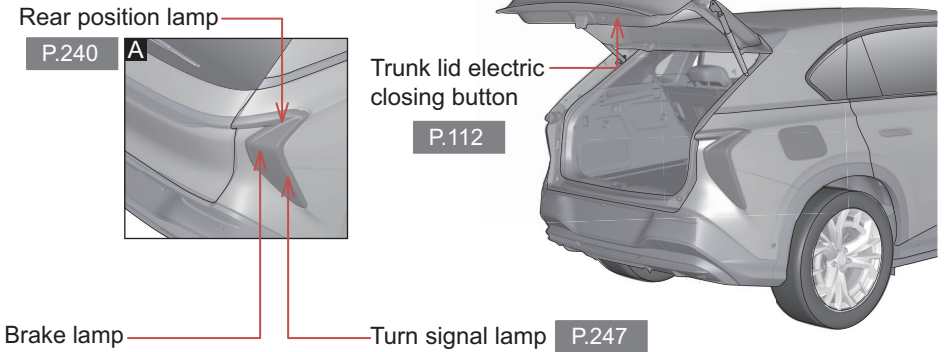
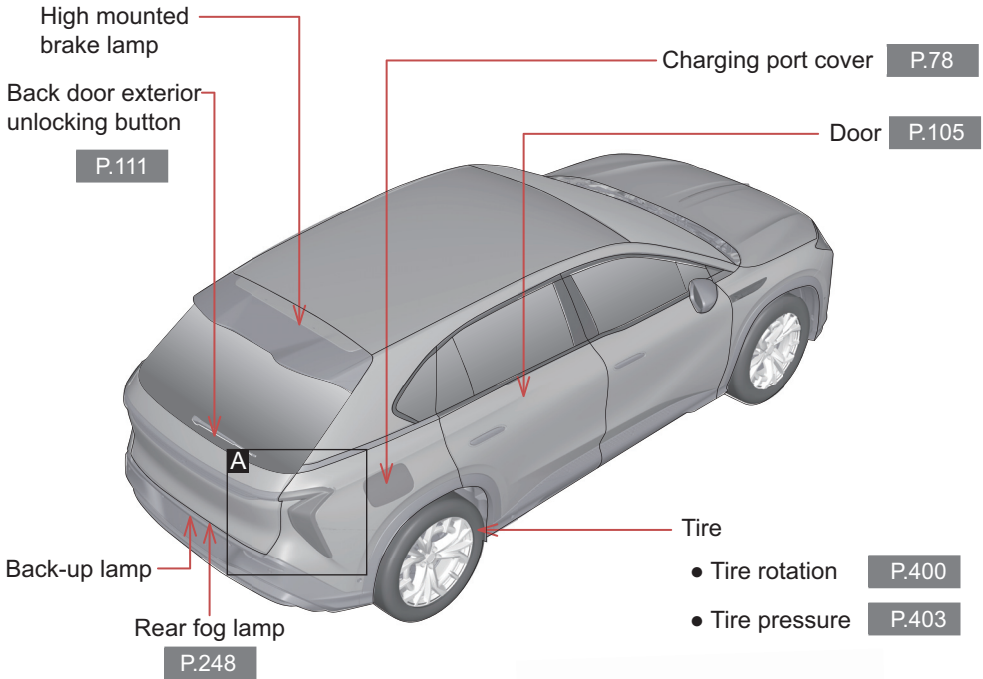

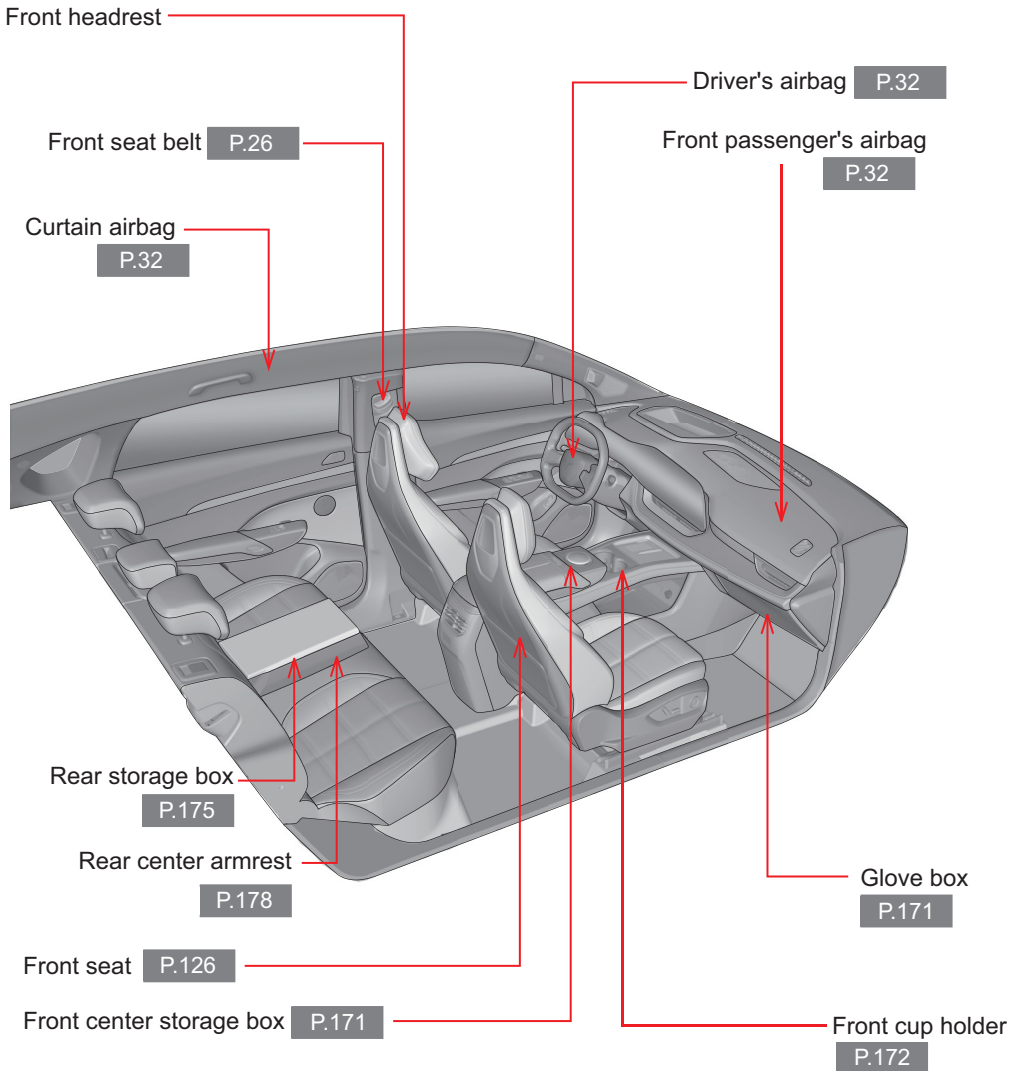

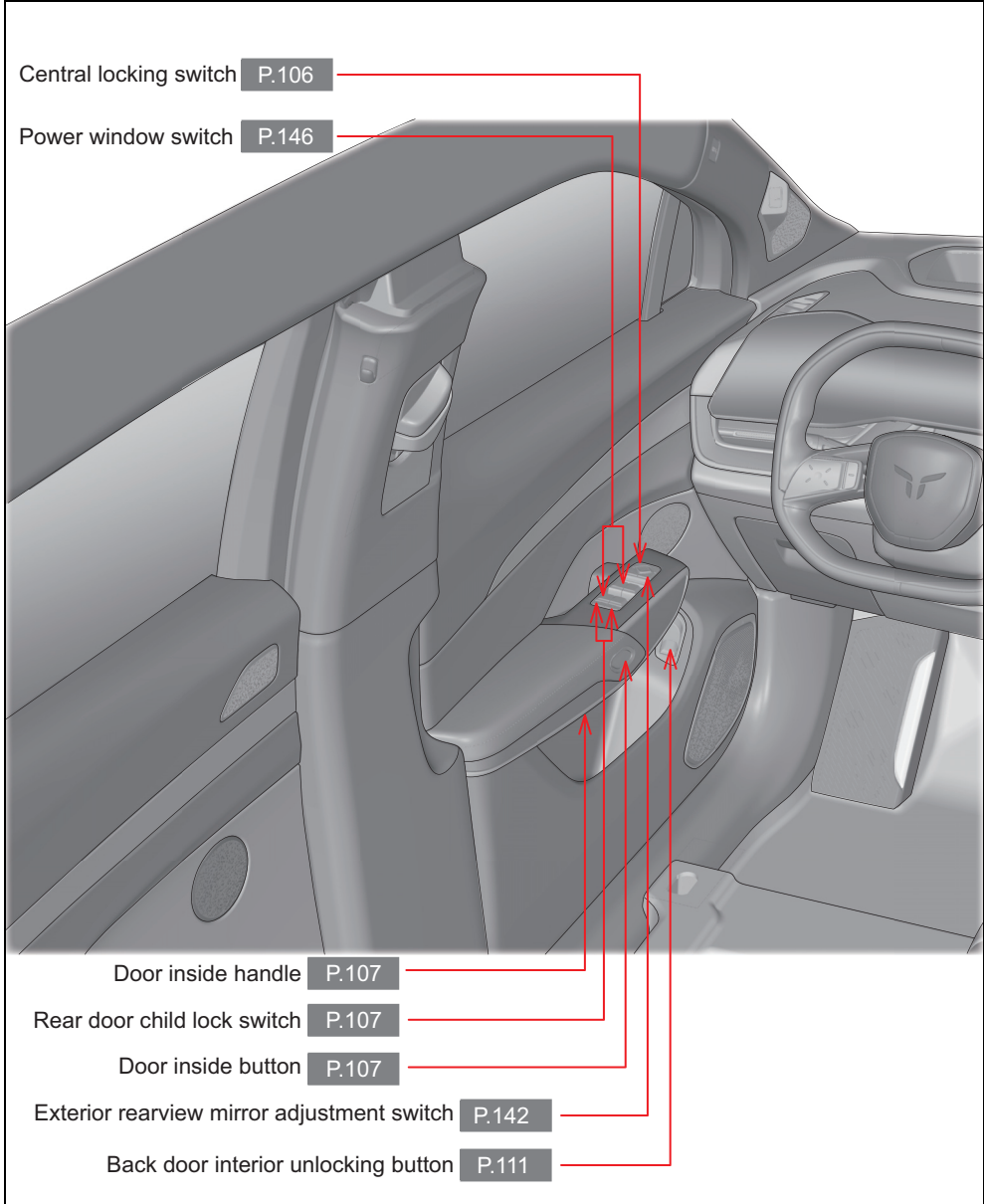

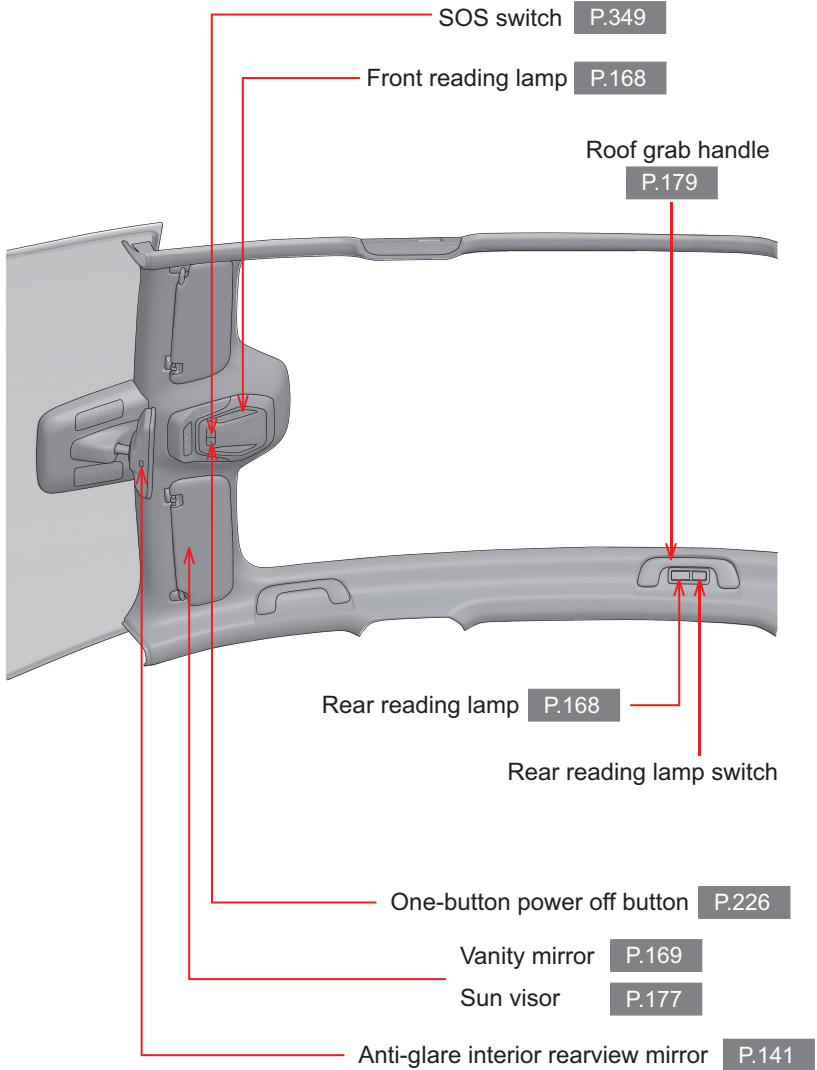

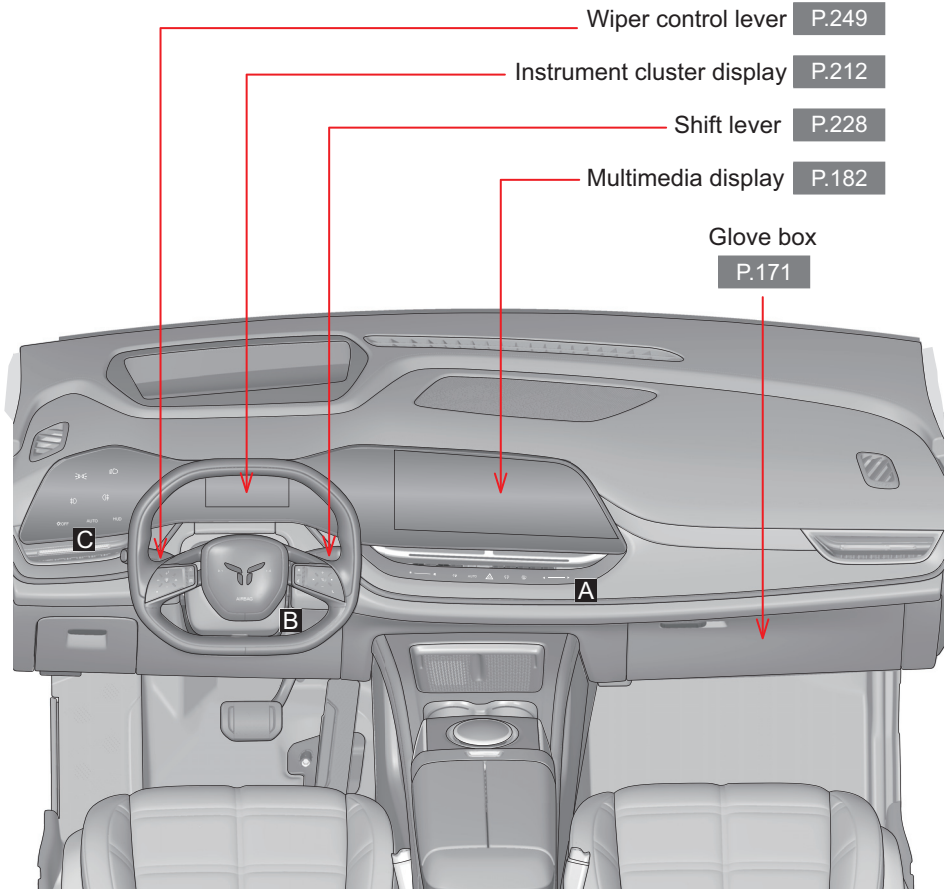

**A**

Hazard warning lamp switch **P.348**

AUTO button **P.150**

ON/OFF button **P.150**

Driver air volume setting button **P.150**

Front windshield forced defrosting/defogging button **P.150**

Windshield/exterior rearview mirror defrosting/defogging button **P.150**

Driver temperature setting button **P.150**

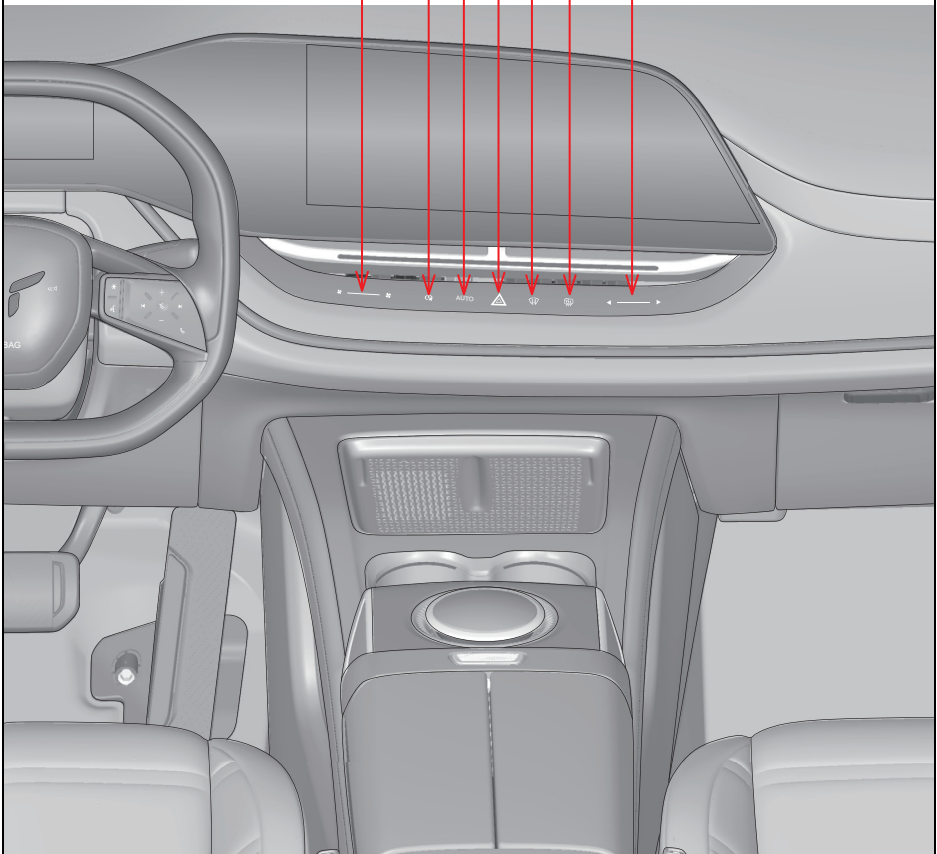



**B**

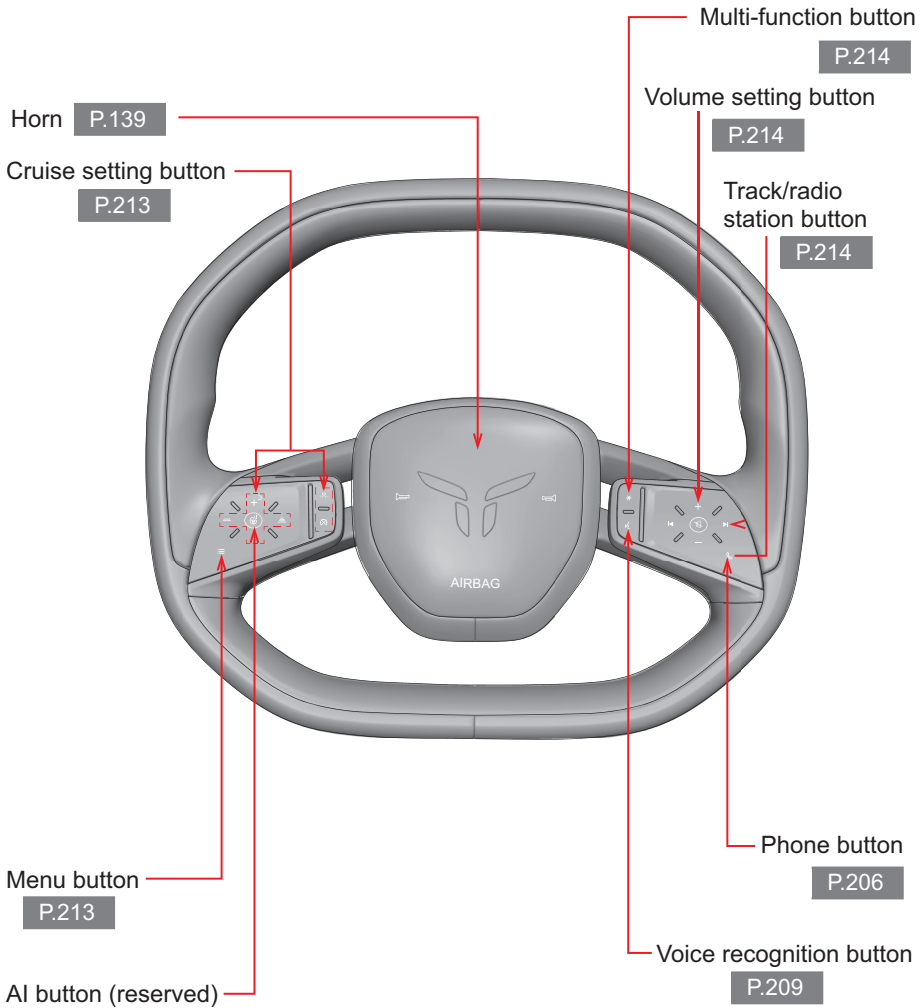

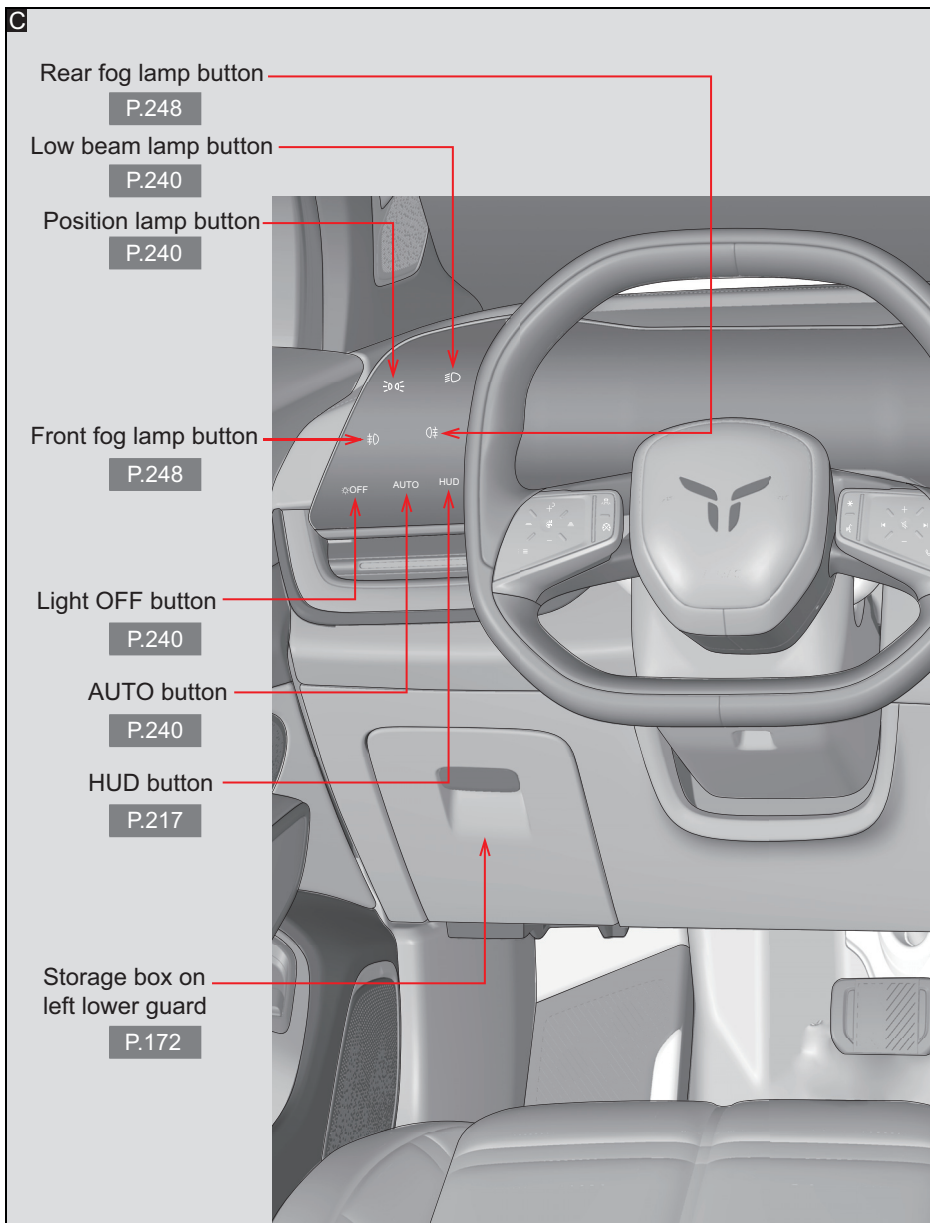

Rear center armrest

P.178

Rear seat

P.128

Rear headrest

P.131

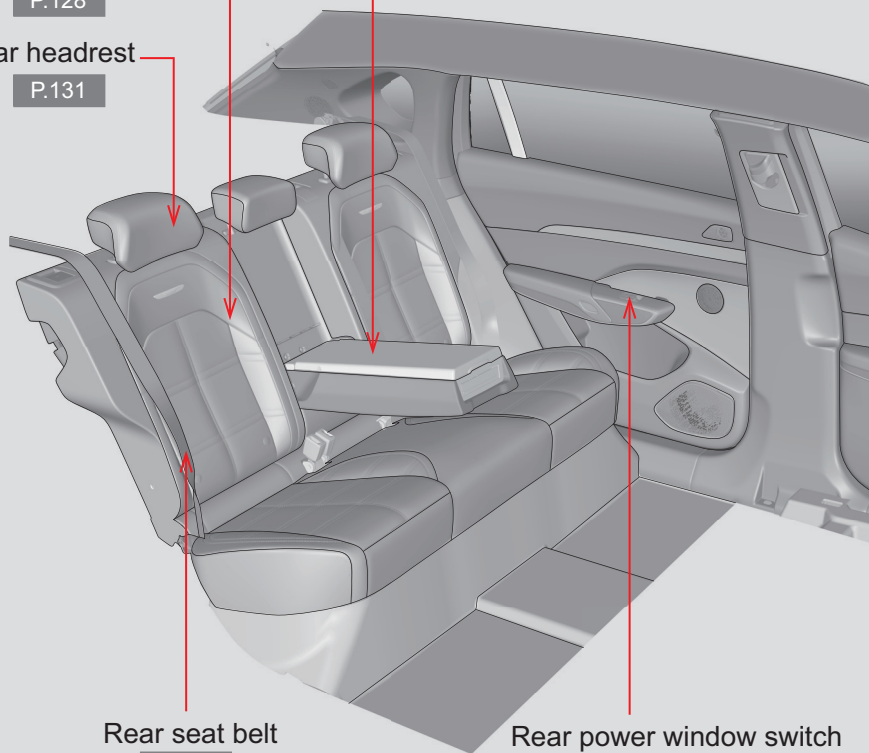

Rear seat belt

P.27

Rear power window switch

P.146

## Reference information

### Accessories, spare parts and modifications of vehicle

An authorized FAW Hongqi dealer has the advanced tools, equipment and genuine spare parts for the maintenance and service of your vehicle. We strongly recommend that you use FAW genuine spare parts and accessories that meet the requirements of this vehicle.

For any non-genuine spare parts or accessories, whether they are used for replacement or installation, FAW neither assumes any responsibility nor provides any guarantee. In addition, vehicle damage and performance problems due to the use of the above-mentioned spare parts or accessories are not covered by free repair.

It is prohibited to illegally modify the vehicle with products not authorized by FAW, otherwise it may affect the safety, handling and durability of the vehicle, and may even violate local government regulations. In addition, problems due to modifications are not covered by free repair.

### Reading vehicle identification number (VIN)

Use a diagnostic scan tool to connect the OBD port of the vehicle; when reading VDC (central computing unit) information, you can read the VIN. Reading tool can be purchased in the market, and must meet ISO14229, ISO15765, ISO15031, and ISO11898 standards.

### Installing RF transmitter system

Installation of the RF transmitter system may affect some electronic systems in the vehicle such as:

- Antilock brake system
- Cruise control system
- Airbag system
- Seat belt pretensioner system

Before installing the RF transmitter system, please consult an authorized FAW Hongqi dealer.

## Scrapping of vehicle

Since the airbags and seat belt pretensioners contain explosive chemicals, if the vehicle is scrapped without removing them, accidents such as personal injury and fire may occur. Before scrapping the vehicle, be sure to contact a qualified company or institution to remove and dispose of the airbags and seat belt pretensioners. An authorized FAW Hongqi dealer is familiar with relevant laws and regulations and can provide you with consulting services.

## Environmental protection

Used parts and waste oil:

- Dispose of the used parts and waste oil properly
- Improper disposal may lead to environmental pollution
- When scrapping the vehicle, please consult an authorized FAW Hongqi dealer

## Vehicle model

This manual describes CA6490H0EVC, CA6490H0EVXC, CA6490H0EVB, CA6490H0EVXB models.

 **WARNING**

**■ Precautions for driving**

It is important for the driver to drive soberly, carefully and attentively.

- Drive soberly: Never drive the vehicle after drinking or taking medicine. Alcohol or certain medications may delay response time and impair judgment and coordination, thus resulting in serious injury or death.
- Drive carefully: Always drive with caution. Always pay attention to the movements of other vehicles and pedestrians in order to make timely judgments to prevent accidents.
- Drive attentively: Be sure to concentrate on driving. Anything distracting the driver's attention, such as adjusting the control buttons, making a phone call or reading, may lead to a collision and cause serious injury or even death.

**■ Precautions regarding child safety**

- Never leave children unattended in the vehicle.
- Do not allow children to carry or use the key, as children may cause a safety hazard by starting the vehicle or operating the shift lever.
- Do not allow children to play with doors, windows or other vehicle equipment as they may get injured.
- Make sure that the temperature inside the vehicle is appropriate, because too high or too low temperature may cause fatal injury to children.

# Read this manual

## **WARNING**

Explains warnings that, if not obeyed, could cause serious injury or even death.

## **CAUTION**

Explains precautions that, if not obeyed, could cause vehicle damage or malfunction.

**Step 1** Indicates operating or working procedures, which should be performed in numerical order.

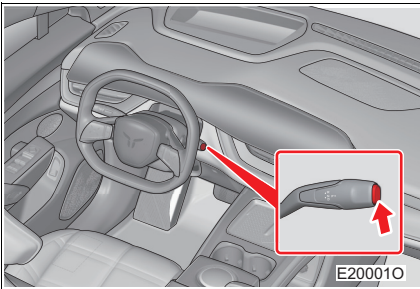

 Indicates the action (push, turn, press, etc.) used to operate the switch and other devices.

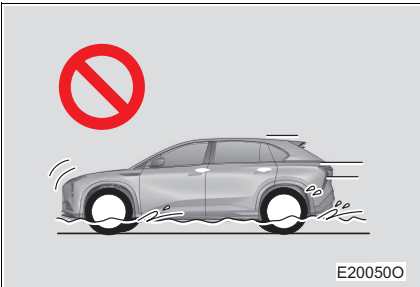

 Indicates "Do not", "Do not do", or "Do not do this".





**1-1. Instructions for safe use**

Safe driving .....24

Seat belt .....26

Airbag .....32

Child safety  
information .....44

Child restraint  
system .....45

Installation of child  
restraint system .....53

High voltage safety ..56

**1-2. Warning lamps and  
indicator lamps**

Indicator lamp .....59

Warning lamp .....61

**1-3. IMMO system/anti-theft  
system**

Immobilizer system ..68

Body anti-theft  
system .....69

# Safe driving

**Before driving, adjust the seat, steering wheel and rearview mirrors to the proper positions to ensure safe driving.**

■ **Correct driving posture**

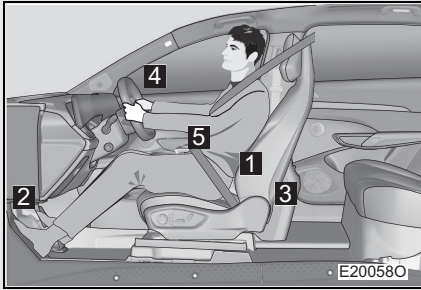

- 1** Sit up straight with your back against the seat back.
- 2** Adjust the seat position forward or backward to ensure that you can depress the pedal to the desired position easily.
- 3** Adjust the seat back for convenient access to various switches.
- 4** Adjust the tilt angle of the steering wheel so that the airbag is facing the driver's chest.
- 5** Fasten the seat belt properly.

■ **Correct use of seat belt**

Before driving, make sure that the driver and all occupants have fastened the seat belts correctly.

Children shall use appropriate child restraint systems until they become large enough to wear the vehicle's seat belt.

■ **Adjustment of rearview mirrors**

Adjust the interior and exterior rearview mirrors properly to ensure a clear rear view.

 **WARNING****■ Precautions when driving**

- Do not adjust the driver's seat while driving as this may result in loss of vehicle control.
- Do not place a cushion between your body and the seat back, as this will hinder proper sitting posture and reduce the effectiveness of seat belt and headrest.
- Do not place objects under the front seats as this may cause the objects to be caught between seat rails.
- During long-distance driving, please take appropriate breaks if you feel tired.  
If you feel tired or drowsy during driving, do not force yourself to continue driving but immediately rest.

**■ Adjustment of seat position**

- Be careful when adjusting the seat position to ensure that the seat does not hurt any other occupants.
- Do not place your hand under the seat or near the moving parts while adjusting the seat, otherwise your fingers may be pinched by seat adjustment device.

# 1-1. Instructions for safe use

## Seat belt

**Before driving, make sure that the driver and all occupants have fastened the seat belts.**

### Correct use of seat belt

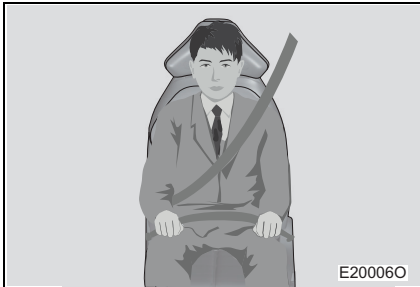

- Stretch the shoulder belt so that it slopes across the shoulder, but does not touch the neck or slip off the shoulder.
- Spread the lap belt as low as possible across the hips.
- Adjust the position of the seat back so that you sit up straight with your back against the seat back.
- Do not twist the seat belt.

### Fastening and unfastening seat belt

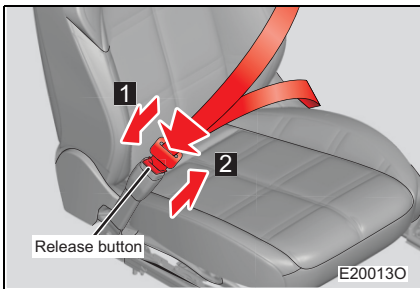

- 1** Fasten the seat belt  
Insert the latch plate into the buckle until you hear a "click" sound.
- 2** Unfasten the seat belt  
Press the release button.

### CAUTION

If any occupant does not fasten the seat belt, the instrument cluster will give an alarm prompt when the vehicle reaches a certain speed.

## Adjusting seat belt height (front seats)

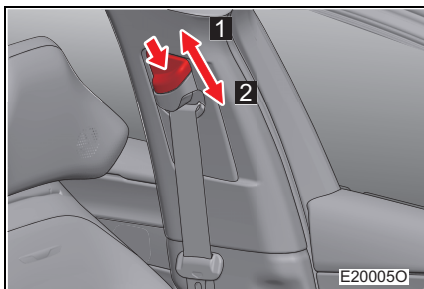

- 1** Move upward
- 2** Move downward  
Press and hold the adjustment button and move the height adjuster up or down as desired until you hear a "click" sound.

## Rear center seat belt

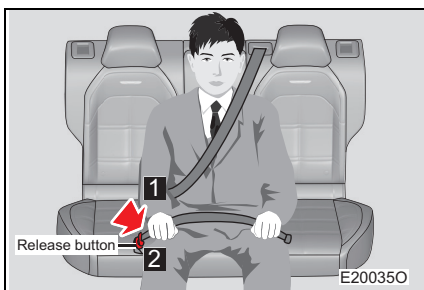

- 1** Fasten the seat belt  
Insert the latch plate into the buckle until you hear a "click" sound.
- 2** Unfasten the seat belt  
Press the release button.

## Seat belt pretensioner

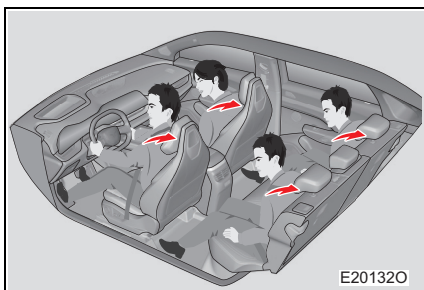

When the vehicle is subjected to a serious frontal collision, the pretensioner will be activated to tighten the seat belt so as to quickly restrain the occupant's body for better protection.

However, the pretensioner may not be activated during a minor frontal collision, side collision or rear-end collision.

---

■ **Emergency locking retractor (ELR)**

The retractor will lock the seat belt in the event of emergency braking or a collision. It will also lock the seat belt if you lean forward too quickly. Slow and smooth movement can stretch the seat belt, so that you can move freely.

■ **Use of child seat belt**

The seat belts on the vehicle are mainly designed for adults.

- Children shall use appropriate child restraint systems until they become large enough to wear the vehicle's seat belt.
- When children become large enough to wear the vehicle's seat belt, follow the instructions for using the seat belt. (See P.26)

■ **Replacement of seat belt after pretensioner activation**

- If the vehicle is involved in multiple collisions, the seat belt pretensioner will be activated during the first collision, but no longer be activated during the second and subsequent collisions.
- After the seat belt pretensioner is activated in a collision, please contact an authorized FAW Hongqi dealer to replace the seat belt in time.

■ **Seat belt regulations**

If there are seat belt regulations in your country or region, please contact an authorized FAW Hongqi dealer for replacement or installation of the seat belt.

## WARNING

To reduce the risk of injury due to emergency braking, emergency steering, or accidents, observe the following precautions; otherwise, serious injury or death may be caused.

### ■ Fasten the seat belt properly

- Make sure that all occupants have fastened the seat belts.
- Be sure to fasten the seat belt correctly at all times.
- Do not over-recline the seat for comfort. The seat belt provides the maximum protection only when you sit up straight with your back against the seat back.
- Do not place the shoulder belt under your arms.
- Be sure to spread the seat belt as low as possible across the hips.

### ■ Pregnant women



- Please follow your doctor's advice and properly fasten the seat belt.
- Like other occupants, pregnant women should also spread the lap belt as low as possible across the hips. The shoulder belt should be stretched obliquely along the shoulders and across the chest, and avoid contact with the raised abdomen.
- If the seat belt is not properly fastened, in emergency braking or a collision, pregnant women and fetus may suffer from serious injury or even death.

### ■ Patients

Please follow your doctor's advice and properly fasten the seat belt.

### ■ When a child is in the vehicle

Do not let the child play the seat belt. If the seat belt is wrapped around the child's neck, asphyxiation or other serious injury that could result in death may be caused.

If the seat belt cannot be unfastened in such a case, cut off the seat belt with a pair of scissors.



## WARNING

### ■ Fasten the seat belt correctly

- It is very dangerous for the driver to sit in the wrong posture or fasten the seat belt in the wrong way. The pretensioners and load limiters cannot provide adequate protection due to incorrect fastening of seat belt, which may result in serious personal injury.
- The incorrect fastening of seat belt is very dangerous. During a collision, an occupant who fastens the seat belt incorrectly may collide with other persons or objects in the vehicle, or may even be thrown out of the vehicle, resulting in serious injury or even death. In the same collision, an occupant who fastens the seat belt correctly will be safer.

### ■ Do not twist the seat belt when fastening it

A twisted seat belt is very dangerous. During a collision, the seat belt cannot fully utilize its full width to absorb the impact force, so that more force is exerted on the bones under the seat belt, which can result in serious injury or even death.

### ■ Do not share a seat belt with others

It is very dangerous to share a seat belt with others (including children). Because the seat belt cannot properly disperse the impact force, and the occupants can collide with each other, causing serious injury or even death.

### ■ Adjustable shoulder belt anchorages (front seats)

Make sure that the shoulder belt crosses the middle of the shoulder. The seat belt should be away from the neck, but shall not slip off the shoulder. Otherwise, the protective effect of the seat belt may be reduced in the event of an accident, and serious injury or death may be caused in case of emergency braking, sudden steering or accident.

### ■ Do not over-recline the seat

Do not over-recline the seat for comfort. The seat belt provides the maximum protection only when you sit up straight with your back against the seat back.

### ■ Do not drive the vehicle with a damaged seat belt

The use of a damaged seat belt is very dangerous. An accident may result in damage to the seat belt. The damaged seat belt fails to provide adequate protection in a collision. After an accident, all seat belt systems shall be thoroughly inspected by an authorized FAW Hongqi dealer before use.



 **WARNING****■ Seat belt pretensioner**

Immediately after any collision, please contact an authorized FAW Hongqi dealer for inspection of seat belt pretensioners and airbags. As with airbags, the seat belt pretensioners can only be used once and must be replaced after activation in a collision. If not replaced, the risk of serious injury to the occupants may be increased during the second collision.

**■ Damage and wear of seat belt**

- Do not allow the seat belt or latch plate get caught in the door as this may damage the seat belt.
- Check the seat belt regularly. Check the seat belt for cuts, wear and looseness. Do not use a damaged seat belt, but replace it. A damaged seat belt cannot protect the occupant and could result in serious injury or even death.
- Make sure that the latch plate and buckle of seat belt are locked and the seat belt is not twisted.  
If the seat belt fails to work properly, please immediately contact an authorized FAW Hongqi dealer.
- If the vehicle is involved in a serious accident, replace the seat belt together with the seat assembly even if there is no significant damage.
- Do not install, remove, modify, disassemble or discard the seat belt without authorization. Please contact an authorized FAW Hongqi dealer for necessary treatment.

 **CAUTION****■ Keep seat belt clean**

If the seat belt is dirty, it may be difficult to be retracted. Please keep the seat belt clean. (See P.379)

# Airbag

The airbag is a passive safety protection device designed to mitigate or avoid the injury to the occupants when the vehicle is subjected to serious collisions that may cause serious injuries to the occupants. In certain serious collisions, the airbag can be deployed. The vehicle is equipped with multiple airbags. The airbags and seat belts work together to reduce the risk of serious injury or even death. (The shape of the deployed airbag is only for reference)

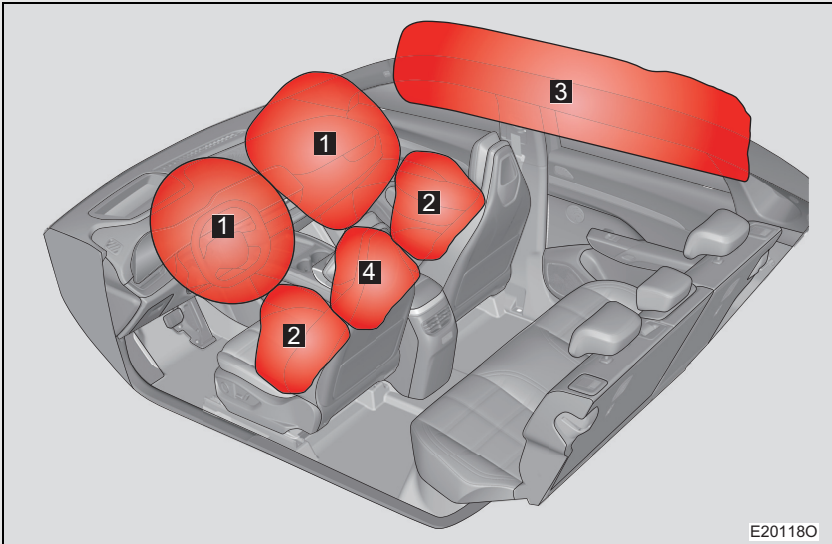

**1** Driver's airbag/front passenger's airbag

To help protect the driver's and front passenger's head and chest from the impact of interior components.

**2** Driver's seat airbag/front passenger's seat airbag

To help protect the driver's and front passenger's torso.

**3** Curtain airbag

To help protect the heads of the driver, front passenger, and rear outer occupant.

**4** Front center airbag

To help protect the driver's and front passenger's torsos from colliding with each other.

## Components of supplemental restraint system (SRS)

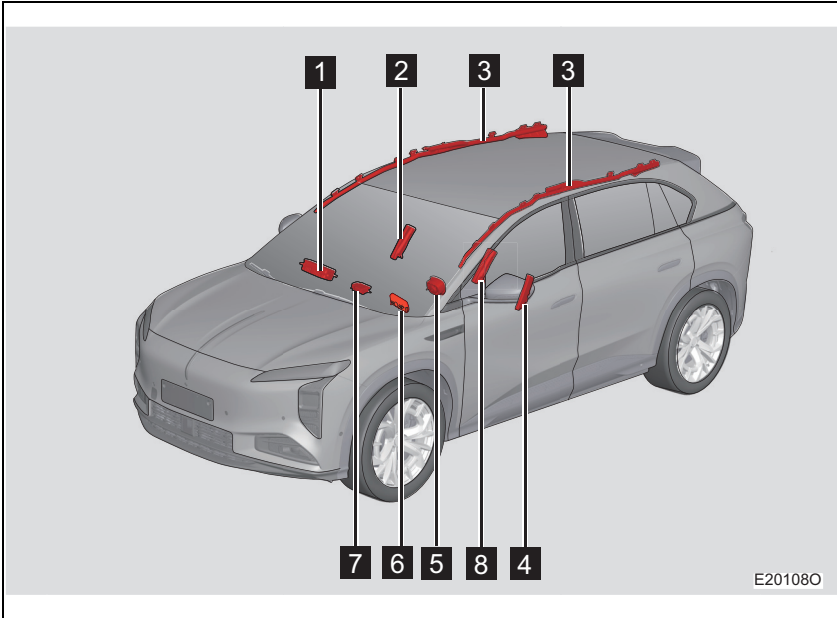

- |                                   |  |
|-----------------------------------|--|
| <b>1</b> Front passenger's airbag | <b>2</b> Front passenger's seat airbag |
| <b>3</b> Curtain airbag           | <b>4</b> Driver's seat airbag          |
| <b>5</b> Driver's airbag          | <b>6</b> SRS fault warning lamp        |
| <b>7</b> Airbag control unit      | <b>8</b> Front center airbag           |

These are the main components of the SRS.

In the event of severe frontal or side collision, the SRS triggers the airbag inflator. The chemical reaction in the airbag inflator can quickly fill the airbag with non-toxic gas to avoid injury to the occupants due to a secondary collision with interior components.



## WARNING

### ■ Precautions for airbag

Please observe the following precautions for airbags. Failure to do so may result in serious personal injury or even death.

- The driver and other occupants in the vehicle must correctly fasten the seat belts.

The airbag is an auxiliary device used in conjunction with the seat belt.

- The driver's airbag deploys with considerable force, and if the driver is too close to the airbag, serious injury or death may be caused.
- The high-risk zone for the driver's airbag is the first 0-100 mm of deployment. Keep at least 300 mm away from the driver's airbag. This is the distance from the center of the steering wheel to the sternum of the driver. If you are sitting at a distance less than 300 mm, you can adjust the driving position using the following methods:
  - Move the seat to the rear as far as possible, but it is still the prerequisite to depress the pedals easily.
  - Slightly tilt the seat back backward. If it is difficult to see the road ahead after the seat back is tilted, use a hard anti-slip seat cushion to lift the body or raise the seat.
  - Adjust the steering wheel to tilt it downward as far as possible. This allows the airbag to face the driver's chest rather than the head and neck.

When the driver's seat is adjusted in accordance with the above recommendations, the pedals and steering wheel should be kept in the driver's control range, and control switches of the instrument panel are within the driver's field of view.

- When scrapping the vehicle or the components of SRS and pretensioner seat belts, please observe the relevant safety regulations.

### ■ Fasten the seat belt properly

Always fasten the seat belt when driving a vehicle equipped with airbags. It is very dangerous to rely solely on the airbag in an accident. Because only the airbag may not be able to avoid serious injury. Therefore, be sure to fasten the seat belt when driving or riding the vehicle.

**⚠ WARNING****■ Precautions for airbag**

- The front passenger's airbag deploys with considerable force, and if the front passenger is too close to the airbag, serious injury or death may be caused. The front passenger's seat should be as far away from the airbag as possible, and the seat back should be adjusted so that the front passenger can sit upright.
- Improperly seated/protected infants and young children may suffer from serious injury or death due to airbag deployment. Infants and young children who are unable to use the seat belts shall be properly restrained by child restraint systems. We strongly recommend that the infants and young children use child seats and the child seats be placed on the rear seats of the vehicle. For infants and young children, the rear seats are safer than the front passenger's seat.

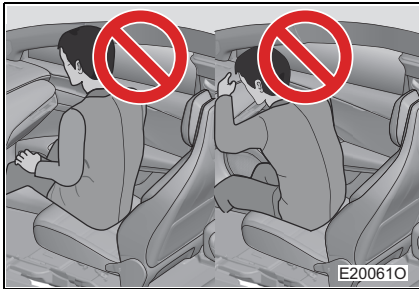

- Do not lean against the instrument panel, A-pillars, roof side rails, door parts or seat edges, otherwise, when the front passenger's airbag is deployed, it may cause a strong head impact, resulting in serious injury or even death (when children are in the vehicle, more attention shall be paid).

 **WARNING**



- Do not allow children to stand in front of the front passenger's airbag.
- Do not place any object or let any child sit on the front passenger's lap.



- Do not lean against the doors, roof side rails, A-pillars or B-pillars.

**⚠ WARNING**

**■ Precautions for airbag**



- Do not face the door and kneel on the seat or extend the head and hand out of the vehicle.

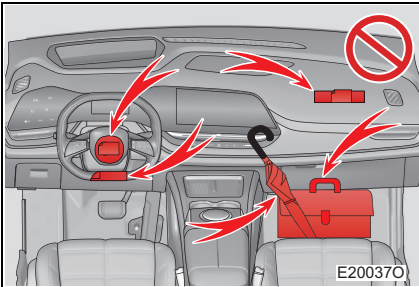

- Do not attach, lean or place any items on the instrument panel, driver's airbag cover, etc. These items may be ejected upon deployment of driver's airbag or front passenger's airbag.

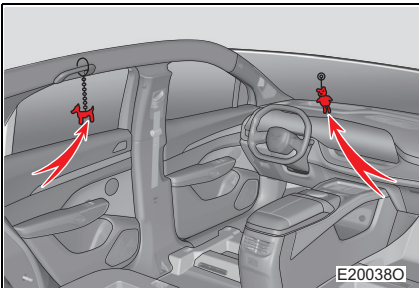

- Do not tie anything to the doors, windshields, windows, A-pillars, B-pillars, C-pillars, roof side rails, roof grab handles, etc.
- Do not hang coat hangers or other hard objects on the coat hooks. If the curtain airbag is deployed, these objects may be ejected, resulting in serious injury or death.



## **WARNING**

### **■ Precautions for airbag**

- Do not use such seat accessories that will cover the seat airbag or its deployment area (such as seat cover etc.), as they may interfere with deployment of the airbag.
- Do not strike the area where the airbag is located or apply excessive force to it, as this may cause the airbag to malfunction.
- Do not touch the related parts immediately after the airbag is deployed (inflated), as they may be hot.
- If you feel it difficult to breathe after deployment of the airbag, open the door or window for ventilation, or leave the vehicle if it is safe to do so. Rinse the residue on the body as soon as possible so as to avoid skin irritation.
- If the area where the airbag is located (such as the driver's airbag cover and instrument panel) is damaged or cracked, please contact an authorized FAW Hongqi dealer for replacement.

### **■ After the airbag is deployed in the event of a collision**

The SRS can only provide the protection in an accident for one time. After the airbag is deployed in the event of a collision, please go to an authorized FAW Hongqi dealer for replacement of airbag, airbag control unit and related components, and the original components shall not be used.

### **■ Modification and scrapping of SRS components**

Please do not scrap the vehicle or make the following modifications before consulting an authorized FAW Hongqi dealer.

Otherwise, the airbag may malfunction or deploy (inflate) unintentionally, resulting in serious injury or even death.

- Installation, removal, disassembly and repair of airbag.
- Repair, modification, removal or replacement of steering wheel, instrument panel, seat or seat trims, A-pillar, B-pillar, C-pillar or roof side rail.
- Repair or modification of front fender, front bumper or sides of passenger compartment.
- Retrofitting of front grille with snow plow, winch and other tools.
- Modification of suspension system.
- Installation of portable two-way radio.



### ■ When the airbag is deployed (inflated)

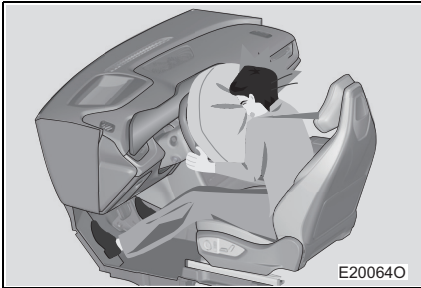

- The airbag deploys with considerable force, and if the occupant is too close to the airbag, serious injury or death may be caused.
  - The airbag deploys with ignition sound and smoke, but no fire will occur. If people with respiratory tract diseases such as asthma inhale the gas, they may experience breathing difficulties. In this case, it is relatively safe to immediately evacuate from the vehicle. If evacuation is impossible, open the windows and doors to take in the fresh air.
- The airbag deployment speed is very high, which may cause minor scratch, scalding or other injuries.
  - If the residue (gas, etc.) from airbag deployment splashes into the eyes or attaches to the skin, rinse the affected area with fresh water as soon as possible. Sensitive skin may have allergic reactions.
  - In addition to the airbag itself, the SRS module components (including airbag cover and inflator), as well as the steering wheel, instrument panel, seat, A-pillar, B-pillar, C-pillar and roof side rail may become hot in a few minutes.
  - The front windshield may be broken.
- ### ■ Airbag trigger factors
- The triggering range of airbag in various accident situations cannot be determined in general terms, because the specific circumstances of the accidents vary greatly. For example, the nature (hardness) of the object that the vehicle collides with, the angle of collision, and the speed of the vehicle are all important trigger factors for the airbag.
  - The decisive trigger factors for the airbag are the deceleration and pressure curves that are produced in the event of a collision. The sensors installed on the vehicle, together with the electronic control units, identify the severity of the collision, and thus selectively trigger the airbag in a timely manner. If the deceleration value or pressure value generated and measured during a collision is lower than the reference value preset in the control unit, the airbag will not deploy even though the vehicle may have been deformed to a certain extent in the accident.

■ **Operating conditions (driver's airbag/front passenger's airbag)**

- In the event of a more severe frontal collision, where the degree of collision exceeds a set threshold, the driver's airbag/front passenger's airbag will be deployed.

However, if the vehicle hits a movable or deformable object (such as a parked vehicle or a signal post) or in case of an "underrun" (such as a collision in which the front of the vehicle "penetrates" beneath a truck's cargo compartment), the airbag may not deploy.

- In some collisions, the forward deceleration of the vehicle is very close to the design threshold, but the frontal airbag and seat belt pretensioner may not be activated.

■ **Operating conditions (seat airbag and curtain airbag)**

- In the event of a severe side collision, the collision degree exceeds the set threshold, the seat airbag and curtain airbag on collision side will deploy.
- In some special accidents, the seat airbag and curtain airbag may deploy together with the driver's airbag/front passenger's airbag.

■ **Other cases where the airbag may deploy (except for collisions)**

If the bottom of the vehicle is severely impacted, the driver's airbag and front passenger's airbag also be deployed.

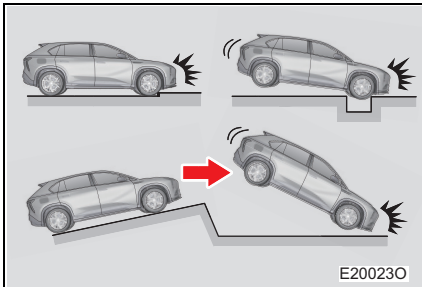

- The vehicle hits a curb, sidewalk edge, or hard surface
- The vehicle falls into or jumps over a deep pit
- The wheels are hard grounded or the vehicle falls

### ■ Cases where the airbag (driver's airbag/front passenger's airbag) may not deploy

The driver's airbag/front passenger's airbag may not deploy during the collision with cylindrical objects such as utility poles and trees, non-frontal collision with walls and highway guardrails, rear-end collision, collision with the rear of truck or going under the bottom of truck, low-speed frontal collision, side collision or rollover. However, as long as the collision causes the vehicle to have a sufficient forward deceleration, the airbag may deploy.

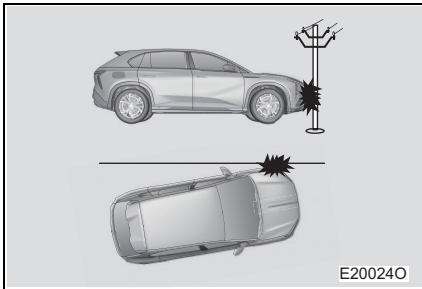

- Collision with cylindrical objects such as utility poles and trees
- Non-frontal collision with walls and highway guardrails

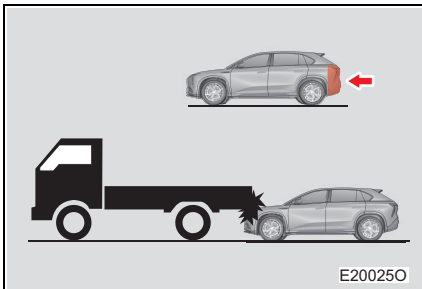

- Rear-end collision
- Collision with the rear of the truck, or going under the bottom of truck

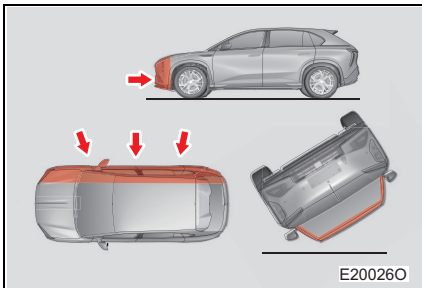

- Low-speed frontal collision
- Side collision
- Rollover

■ **Cases where the airbag (seat airbag/curtain airbag) may not deploy**

If the vehicle is subjected to a side collision of non-passenger compartment, or a side collision of vehicle body at an angle, the seat airbag/curtain airbag may not deploy

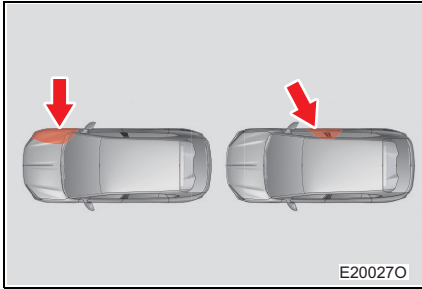

- Side collision of non-passenger compartment
- Side collision of vehicle body at an angle

Generally, the seat airbag/curtain airbag will not deploy when the vehicle is subjected to a low-speed frontal collision, low-speed side collision, rear-end collision or rollover.

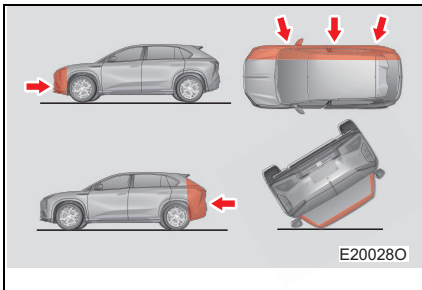

- Low-speed frontal collision
- Low-speed side collision
- Rear-end collision
- Rollover

■ **When to contact an authorized FAW Hongqi dealer**

In the following cases, the vehicle needs to be inspected and/or repaired. Please contact an authorized FAW Hongqi dealer as soon as possible.

- Any airbag has been deployed.

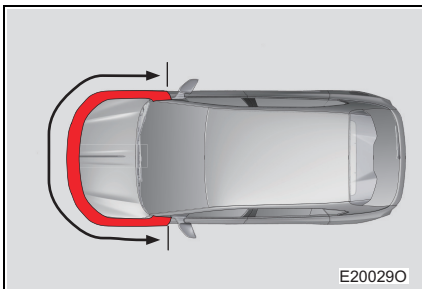

- The front of the vehicle is damaged or deformed, or a collision in which the airbag is not deployed has occurred.

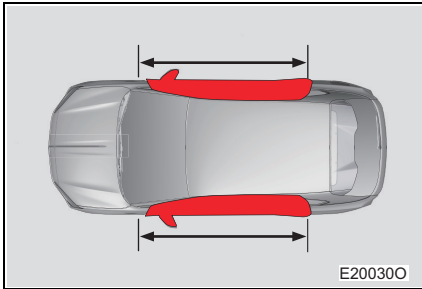

- The door or the area around the door is damaged or deformed, or a collision in which the seat airbag and curtain airbag are not deployed has occurred.

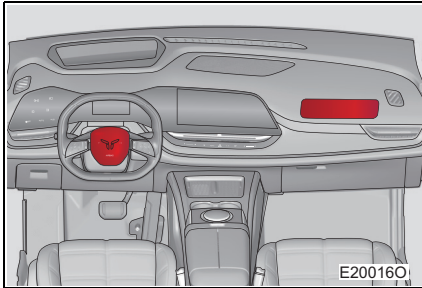

- There are scratches, cracks or other damages on the driver's airbag cover or the instrument panel near the front passenger's airbag.

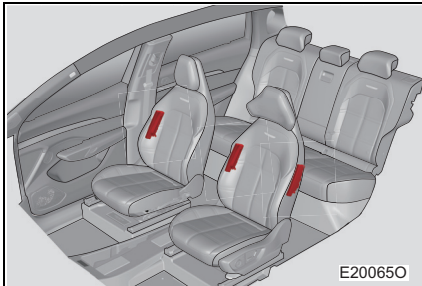

- There are scratches, cracks or other damages on the surface of the seat equipped with seat airbag.

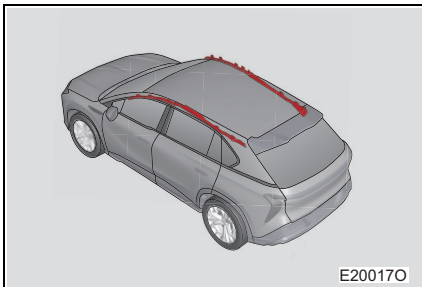

- There are scratches on the curtain airbag, and cracks or other damages on the parts such as the A-pillar, B-pillar, C-pillar protectors, roof, handle, reading lamp, etc.

## Child safety information

**Always observe the following precautions when any child is inside the vehicle.**

**Children shall use appropriate child restraint systems until they become large enough to wear the vehicle's seat belt.**

- It is recommended that the child sit in the rear seats to prevent accidental contact with the shift lever, wiper switch, etc.
- During driving, use the rear door safety lock to lock the doors and windows so that the children cannot open the door or operate the power window unexpectedly.
- Do not allow the child to operate devices that may pinch any body part (such as power window, front compartment cover, trunk lid, seat, etc.)

### **WARNING**

■ **Do not allow children to carry the vehicle key or play alone in the vehicle**

Never leave children unattended in the vehicle. Do not allow children to carry or use the key.

Children may start the vehicle or operate the shift lever. Children may also get injured while playing with windows, sunroof or other vehicle equipment. In addition, too high or too low temperature inside the vehicle may cause fatal injury to children.

■ **Always lock the vehicle, and keep the key out of reach of children**

It is dangerous if the vehicle is improperly locked when leaving it stationary or if the key is placed within the reach of children. The child who enters the trunk through an open trunk may get locked in the trunk by accident. Especially in summer, the child may suffer from heat exhaustion, resulting in brain injury and even death. Regardless of whether you have children, always lock the doors and trunk.

# 1-1. Instructions for safe use

## Child restraint system

**FAW strongly recommends that you use the child restraint system.**

### Precautions

An appropriate child restraint system can provide good protection for your child in an accident.

For the child's safety, please carefully read the instructions provided with the child restraint system and in this manual before installing a child restraint system.

### WARNING

- **An appropriate child restraint system must be used for the child when traveling in the vehicle, never carry a child on your lap.**
- **Make sure the child restraint system is properly installed following the instructions provided with the restraint system and in the manual.**
- **Failure to follow the instructions provided with the child restraint system and in this manual may cause injuries and even death to the child in an accident.**

### Front passenger airbag switch

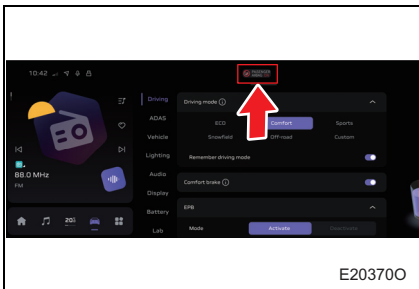

Front passenger airbag ON-OFF switch is located in the multimedia display.

**⚠ WARNING**

- **Never use a rear-facing child restraint system on the front passenger's seat when the front passenger airbag switch is active.**
- **When there is no child restraint system installed on the front PASSENGER seat, please switch the airbag BACK TO the ON position immediately.**

**Child restraint system anchorage**

Second row outside seat

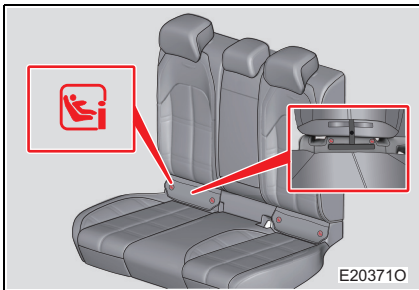

The second row outside seat is equipped with ISOFIX/i-Size anchorage. The anchorage are located between the seat back and seat cushion identified with i-Size markings.

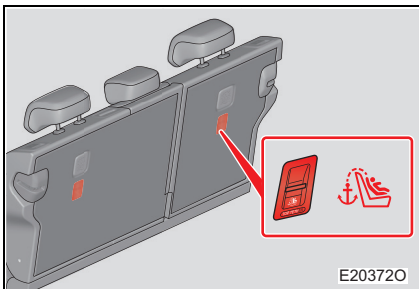

The second row outside seats are equipped with a Top Tether anchorage on the seat back, identified with a Top Tether marking.



**Follow the instructions below when using a child restraint system on front passenger's seat:**

If necessary, please adjust the front passenger's seat backwards so that there is no interaction between the dashboard and the child restraint system/the child.

If necessary, adjust the height of front passenger's seat to ensure the child restraint system is properly restrained.

If necessary, adjust the front passenger's seat back angle to ensure that the seat back provides good support to the child restraint system.

For child restraint system with seat belt guide, please ensure that guide is positioned forward or aligned with the seat belt upper anchorage on the vehicle's B-pillar. Ensure that the seat belt passes through the guide without any twisting.

**Follow the instructions below when using a child restraint system on the second row seat:**

To ensure that the child restraint system/child does not interfere with the front seat, adjust the front seat forward to get more space.

The headrest can be adjusted or even removed if possible to ensure that the vehicle seat back provides good support to the child restraint system. However, never remove the headrest when using a booster cushion without the seat back and adjust it to a suitable locking position.

Details on child restraint system installation

	Seating Position					
	Front left	Front right		2 <sup>nd</sup> row left <sup>b)</sup>	2 <sup>nd</sup> row centre <sup>b)</sup>	2 <sup>nd</sup> row right <sup>b)</sup>
		Front passenger airbag ON	Front passenger airbag OFF			
Seating position suitable for universal belted (Yes/No)	No	Yes <sup>a)c)</sup>	Yes <sup>a)</sup>	Yes	Yes	Yes
i-Size seating position (Yes/No)	No	No	No	Yes	No	Yes
Seating position suitable for lateral fixture (L1/L2/No)	No	No	No	No	No	No
Largest suitable rearward-facing fixture(R1/R2X/R2/R3/No)	No	No	No	R1/R2X/R2/R3	No	R1/R2X/R2/R3
Largest suitable forward-facing fixture(F1/F2X/F2/F3/No)	No	No	No	F1/F2X/F2/F3	No	F1/F2X/F2/F3

	Seating Position					
	Front left	Front right		2 <sup>nd</sup> row left <sup>b)</sup>	2 <sup>nd</sup> row centre <sup>b)</sup>	2 <sup>nd</sup> row right <sup>b)</sup>
		Front passenger airbag ON	Front passenger airbag OFF			
Largest suitable booster fixture (B2/B3/No)	No	(B2/B3) <sup>d)e)</sup>	(B2/B3) <sup>d)e)</sup>	B2/B3	(B2/B3) <sup>d)</sup>	B2/B3

**Note:**

- a): Adjust the seat to the high position as much as possible and adjust the seatback angle in vertical.
- b): If needed, the headrest can be adjusted or removed, but never remove the headrest when using a booster cushion without the seatback.
- c): Only applicable for forward-facing child seat.
- d): Only applicable for installation with seatbelt.
- e): Adjust the front passenger seat as high as possible after the placement of the fixture.

## Recommended child restraint system

Grouping of child stature according to ECE R129 regulation

Child stature	Manufacturer	Child restraint system	Vehicle accessories
40-83 cm	Maxi-Cosi	Pebble 360	Seat belt
76-105 cm	Britax Romer	Trifix <sup>2</sup> i-Size	ISOFIX and upper tether
100 - 150 cm	Britax Romer	Kidfix i-Size *	ISOFIX and seat belt
137 - 150 cm	GRACO	Booster MAX	ISOFIX and seat belt
*: For the best child protection, ensure to pass the seat belt through the Secure Guard and XP-PAD			

### ■ Choose an appropriate child restraint system

- Children shall use appropriate child restraint systems until they become large enough to wear the vehicle's seat belt.
- If the child cannot use a child restraint system due to large body size, place the child in the second row seat and use the seat belt of the vehicle.
- Ensure that the CRS is the correct type for the seating position.

 **WARNING****■ Manufacturer's instructions for child restraint system**

Always observe the manufacturer's instructions when selecting, installing and using a child restraint system, otherwise the desired protection may not be obtained.

**■ When a child is in the vehicle**

Do not let the child play the seat belt. If the seat belt twists around the neck, the child may suffer from suffocation or other serious injury, and even death. If the seat belt cannot be unfastened in such a case, cut off the seat belt with a pair of scissors.

**■ When the child restraint system is not used**

- The child restraint system should be properly secured on the seat even if it is not being used.
- Do not place an unsecured child restraint system in the passenger compartment.
- If the child restraint system must be removed, remove it and secure it in the trunk. If the headrest is raised to facilitate the installation of child restraint system, be sure to adjust the headrest to a proper position before driving. Otherwise, the occupants may get injured in case of emergency braking or accident.

**■ Use the child restraint system**

If an inappropriate child restraint system is used for this vehicle, the infant or child may not be properly protected, and the serious injury and even death may occur (in case of emergency braking or accident).



**WARNING**

**■ Precautions for child restraint system**

- The child must be restrained by a seat belt or child restraint system according to the weight and size of the child to effectively protect the child in the event of an accident and emergency braking. Holding the child in your arms does not replace the role of a child restraint system. During an accident, the child may collide with the windshield or be squeezed between you and the compartment.
- Vehicles with seat airbags and curtain airbags: Even if the child restraint system is properly used, the head or any part of body cannot lean against the door, seat or roof side rail (where the seat airbag or curtain airbag may deploy). Otherwise, the large impact force generated by the deployed seat airbag or curtain airbag may result in serious injury and even death to the child.
- Always follow the manufacturer's instructions and make sure the child restraint system is securely fastened at all times.  
Failure to secure the child restraint system is very dangerous. During emergency braking or a collision, the child restraint system may move, causing serious injury or death to the child or other occupants.

# Installation of child restraint system

**Please observe the instructions provided by the child restraint system manufacturer. Secure the child restraint system firmly to the seat with ISOFIX rigid anchorages. Fix the Top Tether during the installation of the child restraint system.**

## Installation with ISOFIX/i-Size rigid anchorages

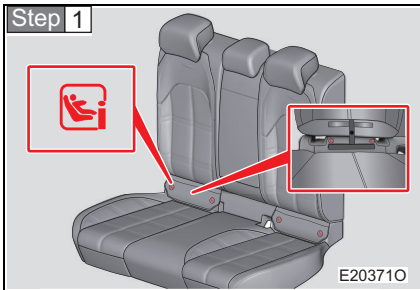

Lift the ISOFIX/i-Size rigid anchorages curtain, and twist the bracket to support the curtain. Ensure that the ISOFIX/i-Size rigid fixing anchorages are fully exposed.

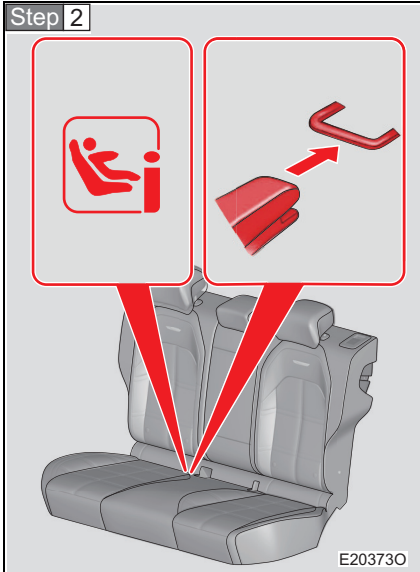

Insert the child seat buckles to the ISOFIX/i-Size rigid anchorages, ensure that buckles are locked securely.

If the headrest interferes with the child restraint system and cannot be installed properly, raise the headrest upward before installing the child restraint system.

If the child restraint system has a Top Tether, fix the Top Tether onto the anchorage support.

## Child restraint system with Top Tether

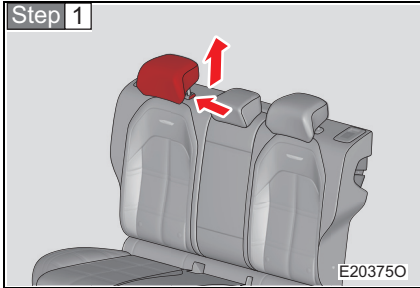

Secure the child restraint system with ISOFIX/i-Size rigid anchorages.

If the headrest interferes with the child restraint system and cannot be installed properly, adjust the headrest upward before installing the child restraint system.

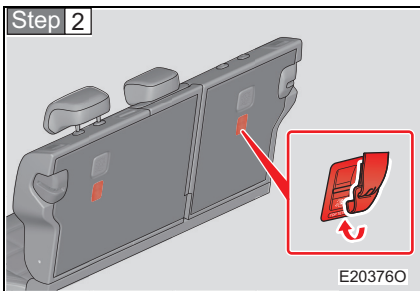

Clamp the hook onto the anchorage support, and fasten the Top Tether.

Make sure that the Top Tether is fastened.

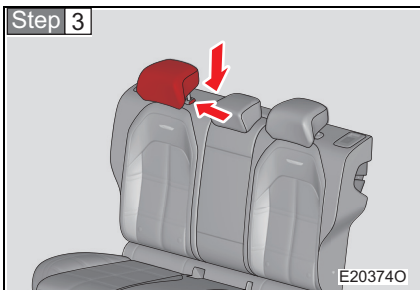

Recover the headrest to the correct position.



## WARNING

### ■ When installing the child restraint system

Please observe the following precautions, otherwise serious injury or death may occur.

- Tie up the Top Tether firmly, and make sure that the seat belt is not twisted.
- Do not tie the Top Tether to any object rather than the anchorage support.
- Push and pull the child restraint system in different directions to make sure it is securely installed.
- Do not adjust the seat after the child restraint system is installed. If the seat is adjusted, the safety of the child restraint system should be reconfirmed.
- Please observe the installation instructions provided by the child restraint system manufacturer.



- The labels attached to inner and outer sides of sun visor on front passenger's side remind you not to place rear-facing child restraint system on airbag-protected seat when front passenger's airbag is deployed. For details about label, see the figure.

### ■ Secure the child restraint system to the anchorage correctly

When using a lower anchorage, make sure that there are no foreign objects around the anchorage and that the seat belt is not stuck behind the child restraint system.

# 1-1. Instructions for safe use



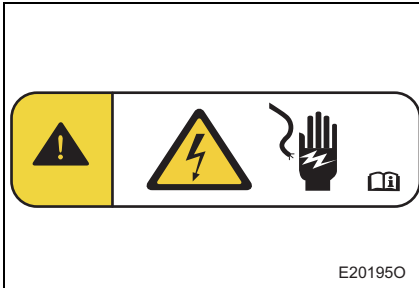

## High voltage safety

The electric vehicle is equipped with high voltage system within level B voltage range. If the vehicle is used improperly, it may cause electric shock or fire hazards to driver, passengers and operators.



The high voltage harness and the high voltage connector are both marked in orange. The high voltage components (except harnesses) are labeled with high voltage marks.

### ■ Meaning of high voltage marks

	Risk of electric shock		Notice
	Read operating instructions		Electric shock

### ■ Active discharge of high voltage system

After the vehicle power supply is turned to OFF mode, the high voltage system actively discharges and releases the remaining voltage from the high voltage components to a safe voltage so as to prevent the occupants from being exposed to high voltage.

### ■ After vehicle collision

- High voltage relay is turned off.
- The high voltage circuit quickly enters an uncharged state to avoid electric shocks.
- The high voltage components are actively discharged.
- It is forbidden to restart or recharge the vehicle.

- **Self-protection measures against the electric shock in vehicle**
  - Think calmly, protect yourself, and do not put yourself at the risk of electric shock.
  - Do not directly touch the person who has been electrically shocked.
  - If possible, immediately cut off the power supply of the electrical equipment (power off at high voltage or disconnect low voltage maintenance switch).
  - Use non-conductive tools (wooden board, broom handle, etc.) to separate the injured person from current conductor or power supply.
- **Medical protective measures against the electric shock from vehicle (the electrocuted person cannot speak)**
  - Rescue on the site, when the electrocuted person is removed from the power source, immediately assess their vital signs, such as pulse and breathing.
  - Call for help immediately and contact the emergency services.
  - Do artificial respiration and chest compression before the doctor arrives.
  - If the electrocuted person stops breathing, use a defibrillator if possible.
- **Medical protective measures against the electric shock from vehicle (the electrocuted person can speak)**
  - Cool down the burned wound and cover it with a sterilized towel.
  - To avoid delayed complications, immediately send the injured person to the doctor for assistance.
- **Rescue in case of electrical fire**
  - Protect yourself and do not inhale smoke.
  - Call the fire department.
  - Carbon dioxide fire extinguisher or foam fire extinguisher should be used when extinguishing fires on electrical equipment.
  - Do not use a carbon dioxide fire extinguisher to extinguish fires on individuals, as there is a risk of suffocation.
  - Place the fire extinguisher within easy reach, and arrange persons to inspect it regularly.



## WARNING

### ■ Precautions on high voltage system

Please observe the following precautions. Failure to do so may result in serious personal injury or even death.

- Contact with all high voltage components should be avoided as much as possible. In the case of insulation failure of the high voltage system, the shell of the high voltage component may carry high voltage.
- If it is found that the shell of the high voltage component or the high voltage harness is damaged, do not directly touch it, and contact the authorized FAW Hongqi dealer immediately. Touching the damaged part with hands or conductive objects may result in electric shock.
- It is prohibited to remove and repair components and high voltage cables with high voltage safety marks without authorization. If you need to remove and repair high voltage system components, please contact the authorized FAW Hongqi dealer.
- Do not spray high voltage components directly with spray pipes and high pressure cleaning devices.
- When inspecting and repairing high voltage conductive parts and accessories, the high voltage system must be powered off first.
- Do not contact the liquid and exhaust gas from the power battery, which may be toxic or flammable.
- Damaged vehicle or power battery can cause immediate or delayed escape of toxic gases, which can easily cause a fire. When damage occurs, be sure to open the window so that the escaping gas can be discharged from the vehicle, and do not inhale such gas.
- Do not use engine oil, lubricating oil, etc. on the high voltage connector.
- In case of fire, leave the dangerous area and call the fire telephone, and inform the rescue personnel that the vehicle is an electric vehicle.

# Indicator lamp

**Indicator lamps indicate the current working status of the vehicle systems.**

- |  |  |   |                                       |
|--|--|---|---------------------------------------|
|   | Left turn signal indicator lamp              |    | Right turn signal indicator lamp      |
|   | High beam ON indicator lamp                  |    | Position lamp ON indicator lamp       |
|   | Low beam ON indicator lamp                   |    | Rear fog lamp ON indicator lamp       |
|   | Front fog lamp ON indicator lamp             |    | ESC system OFF indicator lamp         |
|   | ESC system working indicator lamp (Flashing) |    | Maximum speed limit indicator lamp    |
|  | "READY" indicator lamp                       |    | Door opening indicator lamp           |
|   | HDC system working indicator lamp            |    | APA system working indicator lamp     |
|    | EPB working indicator lamp                   |   | AUTO HOLD working indicator lamp      |
|   | FCW system OFF indicator lamp                |  | AEB system OFF indicator lamp         |
|   | LDW/LKA system ON indicator lamp             |  | LDW/LKA system working indicator lamp |
|   | DSM system warning indicator lamp            |  | IHC system working indicator lamp     |
|   | Intelligent speed limit indicator lamp       |  | Distraction alarm indicator lamp      |
|   | ACC system ON indicator lamp                 |  | ACC system working indicator lamp     |



SACC system steering assist ON indicator lamp



Right assist EMA emergency collision avoidance turn signal indicator lamp



Maintenance indicator lamp



Indicator lamp for failing to identify key



Air suspension height indicator lamp



SACC system steering assist working indicator lamp



Left assist EMA emergency collision avoidance turn signal indicator lamp



Charging connection indicator lamp















BSD function OFF indicator lamp

# Warning lamp









If any warning lamp comes on or flashes, please keep calm and take the following measures. If any warning lamp comes on or flashes but then goes out, it does not necessarily indicate that the system is faulty. However, if this situation persists, please contact an authorized FAW Hongqi dealer to inspect the vehicle.







## List of warning lamps









Warning lamp	Warning lamp/detailed description/countermeasures
	<p><b>Low charge state warning lamp</b></p> <ul style="list-style-type: none"> <li>• It indicates power battery is low.</li> </ul> <p>→ <b>Please charge or contact an authorized FAW Hongqi dealer.</b></p>
	<p><b>Power battery system fault warning lamp</b></p> <ul style="list-style-type: none"> <li>• It indicates a fault in the power battery system.</li> </ul> <p>→ <b>Immediately park the vehicle in a safe place and contact an authorized FAW Hongqi dealer.</b></p>
	<p><b>12 V battery charging fault warning lamp</b></p> <ul style="list-style-type: none"> <li>• If the warning lamp remains on, it indicates a fault in the 12 V battery charging system.</li> </ul> <p>→ <b>Immediately park the vehicle in a safe place and contact an authorized FAW Hongqi dealer.</b></p>
	<p><b>Bulb fault warning lamp</b></p> <ul style="list-style-type: none"> <li>• It indicates a fault in external lamp units.</li> </ul> <p>→ <b>Check for faults in external lamp units and harness connectors or contact an authorized FAW Hongqi dealer immediately.</b></p>
	<p><b>SRS fault warning lamp</b></p> <ul style="list-style-type: none"> <li>• It indicates a fault in SRS.</li> </ul> <p>→ <b>Immediately contact an authorized FAW Hongqi dealer.</b></p>







Warning lamp	Warning lamp/detailed description/countermeasures
	<p><b>Seat belt unfastened warning lamp</b></p> <ul style="list-style-type: none"> <li>• It indicates that the driver's or passenger's seat belt is not fastened.</li> </ul> <p>→ <b>Fasten the driver's and passenger's seat belts.</b></p>
	<p><b>Electronic shift system fault warning lamp</b></p> <ul style="list-style-type: none"> <li>• It indicates a fault in electronic shift system.</li> </ul> <p>→ <b>Immediately park the vehicle in a safe place and contact an authorized FAW Hongqi dealer.</b></p>
	<p><b>PEPS fault warning lamp</b></p> <ul style="list-style-type: none"> <li>• It indicates a fault in PEPS.</li> </ul> <p>→ <b>Immediately contact an authorized FAW Hongqi dealer.</b></p>
	<p><b>Immobilizer system fault warning lamp</b></p> <ul style="list-style-type: none"> <li>• It indicates a fault in immobilizer system.</li> </ul> <p>→ <b>Immediately contact an authorized FAW Hongqi dealer.</b></p>
	<p><b>Low key battery warning lamp</b></p> <ul style="list-style-type: none"> <li>• It indicates a low key battery.</li> </ul> <p>→ <b>Replace the key battery.</b></p>
	<p><b>Power system fault warning lamp</b></p> <ul style="list-style-type: none"> <li>• It indicates a fault in the power system.</li> </ul> <p>→ <b>Immediately park the vehicle in a safe place and contact an authorized FAW Hongqi dealer.</b></p>
	<p><b>Electronic wiper system fault warning lamp</b></p> <ul style="list-style-type: none"> <li>• It indicates a fault in the electronic wiper system.</li> </ul> <p>→ <b>Immediately contact an authorized FAW Hongqi dealer.</b></p>
	<p><b>Low washer fluid level warning lamp</b></p> <ul style="list-style-type: none"> <li>• It indicates a low washer fluid level.</li> </ul> <p>→ <b>Add washer fluid or contact an authorized FAW Hongqi dealer immediately.</b></p>



Warning lamp	Warning lamp/detailed description/countermeasures
	<p><b>Low brake fluid level/system fault warning lamp</b></p> <ul style="list-style-type: none"> <li>• It indicates a fault in the brake system.</li> </ul> <p>→ <b>Immediately park the vehicle in a safe place and contact an authorized FAW Hongqi dealer. It is risky to keep driving in this case.</b></p>
	<p><b>Brake degradation warning lamp</b></p> <ul style="list-style-type: none"> <li>• It indicates a fault in the brake system.</li> </ul> <p>→ <b>Immediately park the vehicle in a safe place and contact an authorized FAW Hongqi dealer. It is risky to keep driving in this case.</b></p>
	<p><b>EPS system fault warning lamp</b></p> <ul style="list-style-type: none"> <li>• It indicates a fault in EPS.</li> </ul> <p>→ <b>Please drive carefully and contact an authorized FAW Hongqi dealer.</b></p>
	<p><b>EPS system major fault warning lamp</b></p> <ul style="list-style-type: none"> <li>• It indicates a major fault in the EPS.</li> </ul> <p>→ <b>Immediately park the vehicle in a safe place and contact an authorized FAW Hongqi dealer.</b></p>
	<p><b>ABS system fault warning lamp</b></p> <ul style="list-style-type: none"> <li>• It indicates a fault in the ABS system.</li> </ul> <p>→ <b>Immediately contact an authorized FAW Hongqi dealer.</b></p>
	<p><b>EPB system fault warning lamp</b></p> <ul style="list-style-type: none"> <li>• It indicates a fault in the EPB system.</li> </ul> <p>→ <b>Immediately park the vehicle in a safe place and contact an authorized FAW Hongqi dealer.</b></p>
	<p><b>AUTO HOLD system fault warning lamp</b></p> <ul style="list-style-type: none"> <li>• It indicates a fault in the AUTO HOLD system.</li> </ul> <p>→ <b>Immediately contact an authorized FAW Hongqi dealer.</b></p>
	<p><b>V2X system fault warning lamp</b></p> <ul style="list-style-type: none"> <li>• It indicates a fault in the V2X system.</li> </ul> <p>→ <b>Immediately contact an authorized FAW Hongqi dealer.</b></p>

Warning lamp	Warning lamp/detailed description/countermeasures
	<p><b>APA system fault warning lamp</b></p> <ul style="list-style-type: none"> <li>• It indicates a fault in the APA system.</li> </ul> <p>→ <b>Immediately contact an authorized FAW Hongqi dealer.</b></p>
	<p><b>Tire pressure abnormal/TPMS system fault warning lamp</b></p> <ul style="list-style-type: none"> <li>• It indicates a fault in the TPMS system or abnormal tire pressure.</li> </ul> <p>→ <b>Immediately park the vehicle in a safe place and contact an authorized FAW Hongqi dealer.</b></p>
	<p><b>Automatic headlamp/automatic wiper function fault warning lamp</b></p> <ul style="list-style-type: none"> <li>• It indicates a fault in the automatic headlamp/automatic wiper function.</li> </ul> <p>→ <b>Immediately contact an authorized FAW Hongqi dealer.</b></p>
	<p><b>Automatic headlamp leveling system fault warning lamp</b></p> <ul style="list-style-type: none"> <li>• It indicates a fault in the automatic headlamp leveling system.</li> </ul> <p>→ <b>Immediately contact an authorized FAW Hongqi dealer.</b></p>
	<p><b>Driver assistance system fault warning lamp</b></p> <ul style="list-style-type: none"> <li>• It indicates a fault in the driver assistance system.</li> </ul> <p>→ <b>Immediately contact an authorized FAW Hongqi dealer.</b></p>
	<p><b>SOS fault warning lamp</b></p> <ul style="list-style-type: none"> <li>• It indicates a fault in SOS phone.</li> </ul> <p>→ <b>Immediately contact an authorized FAW Hongqi dealer.</b></p>
	<p><b>Low coolant level warning lamp</b></p> <ul style="list-style-type: none"> <li>• It indicates a low coolant level.</li> </ul> <p>→ <b>Immediately contact an authorized FAW Hongqi dealer.</b></p>

Warning lamp	Warning lamp/detailed description/countermeasures
	<p><b>Motor system fault warning lamp</b></p> <ul style="list-style-type: none"> <li>• It indicates a fault in the motor system.</li> </ul> <p>→ <b>Immediately park the vehicle in a safe place and contact an authorized FAW Hongqi dealer.</b></p>
	<p><b>ESC system fault warning lamp (remains on)</b></p> <ul style="list-style-type: none"> <li>• It indicates a fault in the ESC system.</li> </ul> <p>→ <b>Immediately contact an authorized FAW Hongqi dealer.</b></p>
	<p><b>Water heating PTC fault warning lamp</b></p> <ul style="list-style-type: none"> <li>• It indicates a fault in the water heating PTC.</li> </ul> <p>→ <b>Immediately contact an authorized FAW Hongqi dealer.</b></p>
	<p><b>Wireless charging fault warning lamp</b></p> <ul style="list-style-type: none"> <li>• It indicates a fault in the wireless charging function.</li> </ul> <p>→ <b>Immediately contact an authorized FAW Hongqi dealer.</b></p>
	<p><b>Driving recorder fault warning lamp</b></p> <ul style="list-style-type: none"> <li>• It indicates a fault in the driving recorder.</li> </ul> <p>→ <b>Immediately contact an authorized FAW Hongqi dealer.</b></p>
	<p><b>Shock absorber system fault warning lamp</b></p> <ul style="list-style-type: none"> <li>• It indicates a fault in the shock absorber system.</li> </ul> <p>→ <b>Immediately contact an authorized FAW Hongqi dealer.</b></p>
	<p><b>Disconnection device system fault warning lamp</b></p> <ul style="list-style-type: none"> <li>• It indicates a fault in the disconnection system.</li> </ul> <p>→ <b>Immediately contact an authorized FAW Hongqi dealer.</b></p>
	<p><b>HDC system fault warning lamp</b></p> <ul style="list-style-type: none"> <li>• It indicates a fault in the HDC system.</li> </ul> <p>→ <b>Immediately contact an authorized FAW Hongqi dealer.</b></p>

Warning lamp	Warning lamp/detailed description/countermeasures
	<p><b>Thermal management fault warning lamp</b></p> <ul style="list-style-type: none"> <li>• It indicates a fault in the vehicle's cooling system.</li> </ul> <p>→ <b>Immediately contact an authorized FAW Hongqi dealer.</b></p>
	<p><b>Drive power limit warning lamp</b></p> <ul style="list-style-type: none"> <li>• It indicates a limitation in drive power.</li> </ul> <p>→ <b>Please slow down or stop on the roadside, if the fault still does not disappear after a period of time, please immediately contact an authorized FAW Hongqi dealer.</b></p>
	<p><b>12 V battery charging fault warning lamp</b></p> <ul style="list-style-type: none"> <li>• It indicates that the vehicle high voltage cannot be powered on.</li> </ul> <p>→ <b>Immediately park the vehicle in a safe place and contact an authorized FAW Hongqi dealer.</b></p>
	<p><b>Thermal runaway warning lamp</b></p> <ul style="list-style-type: none"> <li>• It indicates that the current battery temperature of vehicle is too high.</li> </ul> <p>→ <b>Immediately park the vehicle in a safe place and leave the vehicle, and contact an authorized FAW Hongqi dealer simultaneously.</b></p>
	<p><b>Fuel pump fault warning lamp</b></p> <ul style="list-style-type: none"> <li>• It indicates a fault in the vehicle's fuel pump.</li> </ul> <p>→ <b>Immediately park the vehicle in a safe place and contact an authorized FAW Hongqi dealer.</b></p>
	<p><b>Coolant temperature too high fault warning lamp</b></p> <ul style="list-style-type: none"> <li>• It indicates a high coolant temperature or a fault in the cooling system.</li> </ul> <p>→ <b>Immediately park the vehicle in a safe place and contact an authorized FAW Hongqi dealer.</b></p>
	<p><b>High voltage system fault warning lamp</b></p> <ul style="list-style-type: none"> <li>• It indicates a fault in the vehicle's high voltage system.</li> </ul> <p>→ <b>Immediately park the vehicle in a safe place and contact an authorized FAW Hongqi dealer.</b></p>

Warning lamp	Warning lamp/detailed description/countermeasures
	<p><b>Swapping lock abnormal warning lamp</b></p> <ul style="list-style-type: none"> <li>• It indicates that the vehicle's power battery lock is locked abnormally</li> </ul> <p>→ <b>Immediately park the vehicle in a safe place and contact an authorized FAW Hongqi dealer.</b></p>

Note: When the high coolant temperature warning indicator lamp or any other indicator lamp comes on, the warning buzzer sounds.

## 1-3.IMMO system/anti-theft system

# Immobilizer system

To prevent the vehicle theft, this vehicle is equipped with smart key. The smart key has a built-in password chip. If the key is not registered in the IMMO system in advance, it is impossible to start the power system with the key. Different information is registered in the key for different vehicles.

Do not leave the key in the vehicle but carry it with you when leaving the vehicle.

This system helps to prevent vehicle theft, but does not prevent all theft and can not guarantee the absolute safety of the vehicle.

Carry the registered/authorized key with you and depress the brake pedal to deactivate the IMMO system.

### ■ Conditions that may cause system failure

- The key was strongly impacted
- The key is flooded
- The key is at a high temperature place (e.g. on the instrument panel exposed to the sun)
- A magnetic key chain is used
- The key has been cleaned with ultrasonic cleaner
- The key has approached or come into contact with a key of other vehicle (key with built-in transponder chip)
- Place the key in an environment with strong magnetic field interference

■ If the vehicle cannot be started by using the correct method, the immobilizer system may fail. Please contact an authorized FAW Hongqi dealer to inspect your vehicle.



### CAUTION

#### ■ Ensure normal operation of the system

Do not modify or disassemble the immobilizer system. Otherwise, the normal operation of the system cannot be guaranteed.

# Body anti-theft system

The body anti-theft system mainly monitors the status of four doors, front compartment cover and back door. When the system detects forced entry, it will give an alarm and make the turn signal lamps flash continuously.

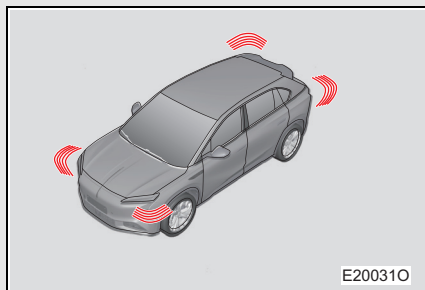

### Body anti-theft system works.

After the driver and all passengers getting off the vehicle, close the doors, back door and front compartment cover and lock all doors.

### Deactivating or stopping the alarm

Perform any of the following operations:

- Use intelligent unlocking, remote unlocking or Hongqi Zhilian APP to remotely unlock the doors or back door.
- Start the power system.

### ■ Items to be checked before locking the vehicle

To prevent accidental alarm triggering, make sure that there are no people, valuables and other personal belongings in the vehicle and all windows are closed before locking the vehicle.

### ■ When 12 V battery is disconnected

Be sure to deactivate the alarm system.

If the battery is disconnected before the alarm is deactivated, the alarm may be triggered after the battery is reconnected.

### CAUTION

### ■ Ensure normal operation of the system

Do not modify or disassemble the IMMO system. Otherwise, the normal operation of the system cannot be guaranteed.





**2-1. Vehicle inspection**

Inspection before driving .....72

**2-2. Driving in winter**

Driving essentials in winter .....73

**2-3. Remote control**

Hongqi Zhilian APP ..75

**2-4. Charging/discharging**

Opening charging port cover .....78

Methods and steps of charging/  
discharging .....81

Display and setting of charging .....92

Charging/discharging troubleshooting .....96

# Inspection before driving

**Before driving, it is recommended to check the followings:**

- Tire
- Lighting
- Whether there are obstacles around the vehicle
- Whether there is any liquid under the vehicle (Water dripping after use of A/C is a normal phenomenon)

Please obey local regulations and designated traffic regulations, and always remember to drive safely.

## Driving essentials in winter

**Before driving in winter, please make necessary preparations and inspections. Be sure to drive in a way suitable for the main weather conditions in winter.**

■ Preparations for driving in winter

- Use oil and fluids suitable for outdoor temperature.
  - Coolant
  - Washer fluid
- Ensure good battery performance.
- If necessary, install four snow tires or install a set of tire chains for driving wheels.

Make sure that all tires are of the same model and brand, and that the size of tire chains matches that of the tires.

■ Before driving

Take the following measures according to driving conditions:

- Do not force open the frozen windows or move the frozen wipers; pour warm water on the frozen parts to melt the ice, and wipe the water immediately to prevent freezing.
- To ensure the normal operation of the fan, clear the snow off the air inlet grille.
- Remove the ice accumulated on the chassis of the vehicle.
- Regularly check and remove the snow and ice that may accumulate on the wheelhouse or brake.
- Remove the snow or mud from soles of shoes before entering the vehicle.

■ During driving

Accelerate slowly and slow down appropriately according to the road conditions.

### Selection of tire chain

Use the correct tire chain size when installing tire chains.

The size of tire chain should be adjusted according to the size of each tire.

## Regulations on the use of tire chains

Depending on the location and type of road, the regulations regarding the use of tire chains will vary. Be sure to check local regulations before installing tire chains.

### ■ Tire chain

When installing and removing tire chains, please observe the following precautions.

- Install and remove tire chains in a safe place.
- Re-tension the tire chains after driving 0.5-1.0 km.
- Install tire chains on the driving tires.
- Follow the instructions provided in the manual attached to the tire chain.



### WARNING

#### ■ Driving with snow tires

In order to avoid the possibility of losing control of the vehicle and causing serious personal injury or even death, and to reduce the risk of accidents, please observe the following precautions:

- Use the specified type of tire.
- Maintain the recommended tire pressure.
- Do not exceed the road speed limit or the prescribed speed limit for snow tires when driving.
- Snow tires should be fitted to all wheels.

#### ■ Driving with tire chains

In order to avoid the possibility of unsafe driving and serious personal injury or even death, and to reduce the risk of accidents, please observe the following precautions:

- Do not exceed the prescribed speed limit for tire chains when driving.
- Avoid driving on uneven or pitted roads.
- Avoid sharp turns or emergency braking.
- Slow down fully before entering the curve to ensure that the vehicle can be controlled.

## 2-3. Remote control

# Hongqi Zhilian APP

The vehicle can be remotely controlled and operated through the mobile APP.

- Open the logged-in Hongqi Zhilian APP to access the APP home.

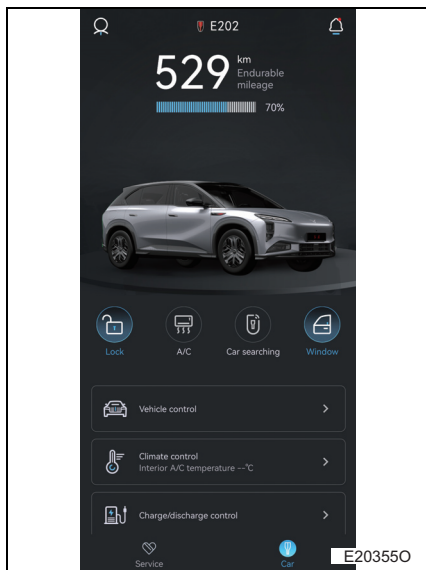

### 1 Exploration

View hotspot, information, dynamic participation or Q&A interaction.

### 2 Activity

View and participate in brand activities, public welfare events, join the Hongqi car club, etc.

### 3 New energy

Information view: View driving range, remaining power and vehicle position etc.

Remote control: On the main interface, you can perform quick operations (locking, window, A/C); You can view and operate the functions such as flashing lamp and sounding horn, exterior rearview mirror heating, charging etc. with [All commands] on the main interface; You can manage the digital key such as activation, view, deletion and other operations by touching [Digital key].

### 4 Mall

You can view products, add to shopping cart and place orders.

### 5 Me

On Me interface, you can operate and view the user information, orders, card wallet, favorites, member rights, inviting friends, feedback, etc.

Touch the setting button at the top left corner of the interface to enter the setting interface, where you can perform operations such as service security password management, changing password, setting emergency contact and my address, clearing cache, and logging out of the account, etc.

## Login

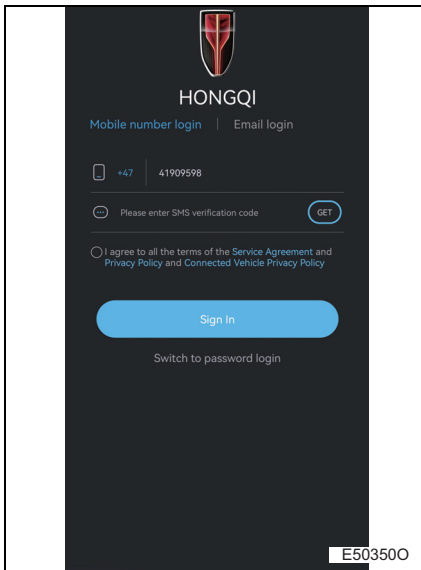

Enter the phone number to obtain the verification code. After entering the verification code, log in to the system.

### ■ APP download

For download and installation of mobile APP, please consult the authorized FAW Hongqi dealer.

### ■ Login information

The Users submit their personal identification information to dealers for real-name authentication. After real-name authentication is completed, please pay attention to receiving information for APP login and PIN code information for vehicle control from the system. For details, please contact the authorized FAW Hongqi dealer.

### ■ Mobile APP version

As the version is constantly updated, the actual operation interface may be different from the illustration. Please refer to the latest version.

### ■ Remote start

Before remote start, make sure all doors, windows, back door and front compartment cover are closed and the vehicle is locked.



## WARNING

### ■ When mobile phone is lost

If your mobile phone is lost, it will increase the risk of vehicle theft. Please keep it properly, and contact the authorized FAW Hongqi dealer if necessary.

### ■ Network connection quality

The network connection quality will vary due to the constant change of antenna position, the difference in signal strength, and the influence of nearby objects (such as trains and transmitting stations), which make it difficult to maintain perfect reception quality.



## CAUTION

### ■ Use permission

When using on-board interconnection, some functions require corresponding permissions, and ensure that the third-party tools do not prohibit the network permissions of on-board interconnection, otherwise the system may not operate properly.

### ■ In case of a fault

If the fault cannot be eliminated, please contact an authorized FAW Hongqi dealer.

# Opening charging port cover

**Perform the following steps to open or close the charging port cover.**

### ■ Opening charging port cover

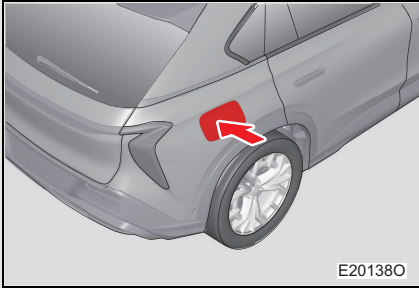

Method 1: When the vehicle is locked and the vehicle power supply is in OFF mode, carry the smart key with you, press the rear end of the charging port cover, and it will open automatically; when the vehicle is unlocked, press the rear end of the charging port cover, and it will open automatically.

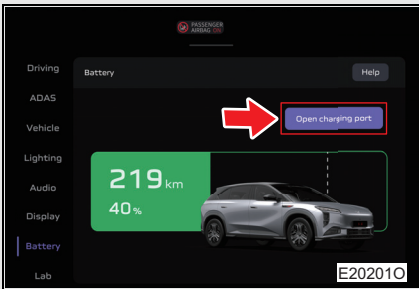

Method 2: Touch the charging port cover switch in the energy settings of the in-vehicle infotainment system, and the charging port cover will open automatically.

### ■ Closing charging port cover

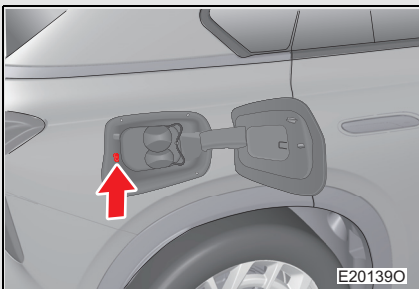

Method 1: Press the charging port cover close button, and the charging port cover will automatically close.



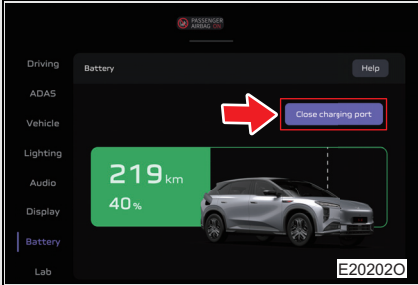

Method 2: When the charging port cover is opened, touch the charging port cover switch in the energy settings of the in-vehicle infotainment system, and the charging port cover will close automatically.

Note: If there are no any operations after charging port cover is opened, the charging port cover will close automatically after 120 seconds.

### ■ Charging port cover activation

(See P.396)

### ■ Emergency unlocking of charging port cover

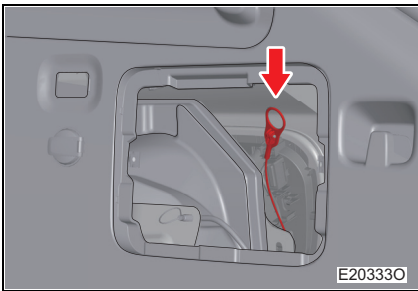

The charging port cover emergency unlocking cable is located in the service port on the right side of the trunk.

When the charging port cover fails to unlock due to insufficient battery or other reasons, it can be unlocked by charging port cover emergency unlocking cable.



### CAUTION

#### ■ Precautions for opening/closing the charging port cover

- Do not push or pull forcefully during the opening and closing of the charging port cover, so as not to damage the charging port cover.
- When the charging port cover fails to reach the desired position, reverses during the opening/closing process or does not act after pressing open button, press and hold the close button for 10 seconds or more, and then release close button to initialize. During initialization, never disconnect battery power supply. If the problem still cannot be solved after initialization, please contact the authorized FAW Hongqi dealer.
- When the charging port cover cannot be opened due to icing around the cover caused by freezing rain, melting snow, or vehicle washing, it is recommended to move the vehicle to a warm environment to defrost and open it. If the problem cannot be solved, please contact the authorized FAW Hongqi dealer.

# Methods and steps of charging/discharging

## Charge with AC charging piles

■ Start charging

**Step 1** Park the vehicle in an AC charging area, depress the brake pedal, set the shift lever to P position, and apply the parking brake.

**Step 2** Open the charging port cover. (See P.78)

**Step 3** Check that the charging plug and the charging socket are clean and free of dirt.

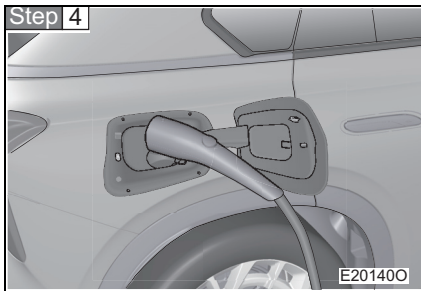

Press the release button and connect the charging plug to the charging socket until a "click" sound is heard, indicating that the charging plug is locked. At this time, the instrument cluster displays that the charging gun is connected, and the AC charging port charging indicator lamp (blue) remains on.

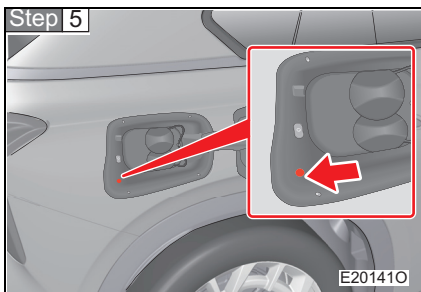

Charge according to the instructions in the AC charging device manual. If the charging has started, the AC charging port charging indicator lamp (green) will flash, and AC charging will be displayed in the instrument cluster.

After charging is completed, the AC charging port charging indicator lamp (green) remains on.

Note: The vehicle can be charged when the vehicle power supply is set to ON/OFF mode.

### ■ Stop charging

**Step 1** Make sure that the AC charging electronic lock is unlocked. (See P.87)

**Step 2** Stop charging according to the instructions of the AC charging device.

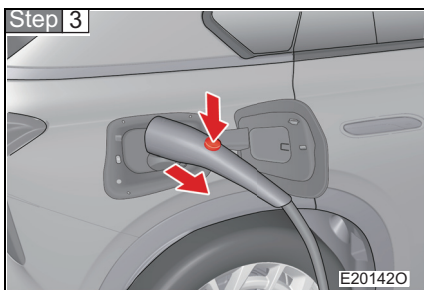

Press the release button and unplug the charging plug from the vehicle end.

The charging connection indicator lamp  on the instrument cluster will go out at this time.

**Step 4** Close the charging port cover. (See P.78)

## Household or industrial electrical socket (220 V) charging\*

### ■ Start charging

**Step 1** Park the vehicle in an AC charging area, depress the brake pedal, set the shift lever to P position, and apply the parking brake.

**Step 2** Take out the AC charging cable for the household or industrial electrical socket (220 V), and check that the power plug and the power socket are clean and free of dirt.

**Step 3** Connect the power plug of the charging cable for household or industrial electrical (220 V) to the power socket. The power supply green indicator lamp on the control box illuminates.

**Step 4** Open the charging port cover. (See P.78)

**Step 5** Check that the charging plug and the charging socket are clean and free of dirt.

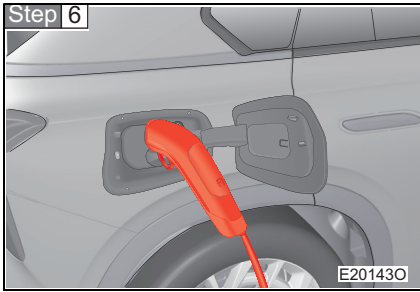

Press the release button and connect the charging plug to the charging socket until hearing a "click" sound indicates that the charging plug is locked. At this time, the instrument cluster displays that the charging gun is connected, and the AC charging port charging indicator lamp (blue) remains on.

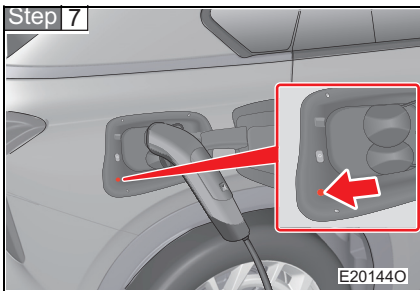

Charge according to the instructions in the AC charging device manual. If the charging has started, the AC charging port charging indicator lamp (green) will flash, and AC charging will be displayed in the instrument cluster.

After charging is completed, the AC charging port charging indicator lamp (green) remains on.

Note: The vehicle can be charged when the vehicle power supply is set to ON/OFF mode.

#### ■ Stop charging

**Step 1** Make sure that the AC charging electronic lock is unlocked. (See P.87)

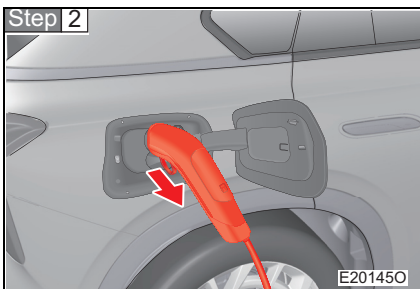

Press the release button and unplug the charging plug from the vehicle end.

The charging connection indicator lamp  on the instrument cluster will go out at this time.

**Step 3** Close the charging port cover. (See P.78)

**Step 4** Unplug the power plug from the power outlet and properly store the AC charging cable for the household or industrial electrical socket (220 V).

### DC charging

#### ■ Start charging

**Step 1** Park the vehicle in a DC charging area, depress the brake pedal, set the shift lever to P position, and apply the parking brake.

**Step 2** Open the charging port cover. (See P.78)

**Step 3** Check that the charging plug and the charging socket are clean and free of dirt.

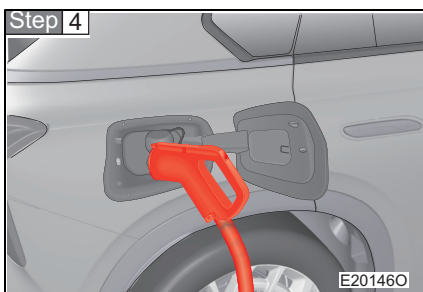

Press the release button and connect the charging plug to the charging socket until hearing a "click" sound indicates that the charging plug is locked. At this time, the instrument cluster displays that the charging gun is connected, and the DC charging port charging indicator lamp (blue) remains on.

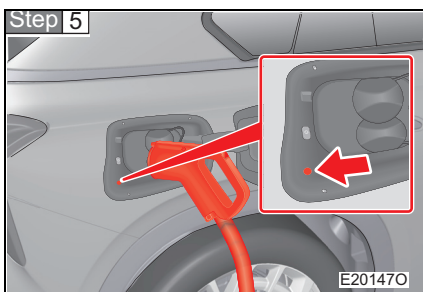

Charge according to the instructions in the DC charging device manual. If the charging has started, the DC charging port charging indicator lamp (green) will flash, and DC charging will be displayed in the instrument cluster.

After charging is completed, the DC charging port charging status indicator lamp (green) remains on.

Note: The vehicle can be charged when the vehicle power supply is set to ON/OFF mode.

### ■ Stop charging

**Step 1** Stop charging according to the instructions of the DC charging device, and make sure that the DC charging electronic lock is unlocked.

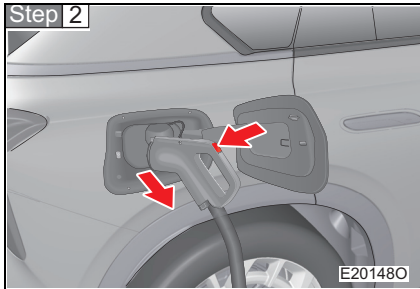

Press the release button and unplug the charging plug from the vehicle end.

The charging connection indicator lamp  on the instrument cluster will go out at this time.

**Step 3** Close the charging port cover. (See P.78)

## AC discharge

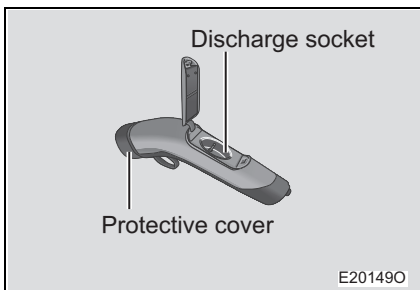

AC discharge gun.

### ■ Start discharging

**Step 1** Park the vehicle in an AC discharging area, depress the brake pedal, set the shift lever to P position, and apply the parking brake.

**Step 2** Open the charging port cover. (See P.78)

**Step 3** Take out the AC discharge gun, and check that the discharging plug and the charging socket are clean and free of dirt.

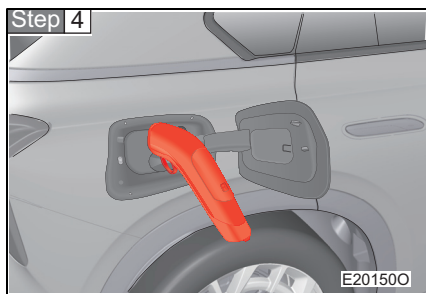

Press the release button and connect the discharge plug to the AC charging socket until hearing a "click" sound indicates that the discharge plug is locked. At this time, the AC charging port charging indicator lamp (blue) remains on.

**Step 5** When the AC charging port charging indicator lamp (purple) remains on, it means that the vehicle is discharging.

Note: The vehicle can be discharged when the vehicle power supply is set to ON or OFF mode.

### ■ Stop discharging

**Step 1** Make sure that the AC charging electronic lock is unlocked. (See P.87)

**Step 2** Turn off the power supply of the household appliance and unplug the household appliance plug from the discharge socket.

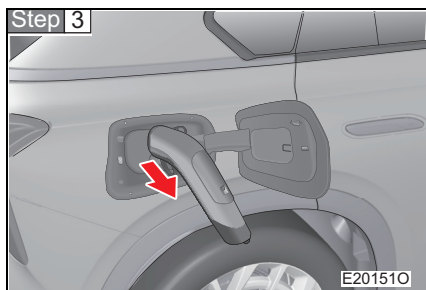

Press the release button and unplug the discharge plug.

**Step 4** Close the charging port cover. (See P.78)

**Step 5** Keep the AC discharge gun properly.



## AC charging electronic lock

The AC charging electronic lock is used to lock the charging/discharging plug so as to prevent the user from disconnecting it during charging/discharging and deterring theft of the charging cable in an unattended environment.

### ■ Locking of AC charging electronic lock

The electronic lock will be locked if any of the following conditions are met:

- When the user fully connects the AC charging/discharging plug to the AC charging port, the electronic lock is automatically locked.
- When the electronic lock is unlocked and the AC charging/discharging plug is maintained in connected state, the electronic lock will automatically lock after 120 seconds.

### ■ Unlocking of AC charging electronic lock

The electronic lock will be unlocked if any of the following conditions are met:

- Users carry the smart key and touch the AC charging port cover closing button (see P.78), and the electronic lock will be unlocked.
- Touch the  button on the in-vehicle infotainment system battery setting interface (see P.195), and the electronic lock will be unlocked.

### ■ Emergency unlocking of AC charging electronic lock

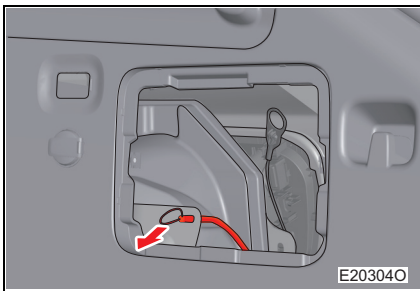

The electronic lock emergency unlocking cable is located in the service port on the right side of the trunk.

When the AC charging electronic lock fails to be unlocked due to insufficient battery or other reasons, it can be unlocked by emergency unlocking cable of AC charging electronic lock.

---

### ■ Remote charging\*

Remote AC charging can be set through mobile phone APP. (See P.75)

### ■ Charging time

The actual charging time is related to the environment and other factors. Please refer to the charging time reminder on the multi-function display of the instrument cluster or the mobile phone APP.

### ■ Charging port indicator lamp

The indicator lamp is used to remind the user about the connection status of the charging/discharging plug and the charging/discharging status.

- When the charging port cover is opened and the charging/discharge plug is not connected, the white indicator lamp of the charging port will come on.
- When the charging/discharging plug is correctly connected to the charging port, the blue indicator lamp of the charging port will come on.
- When the charging/discharge plug is connected incorrectly, the yellow indicator lamp of the charging port will come on.
- During charging, the green indicator lamp of the charging port flashes; When the battery level reaches the limit, the green indicator of the charging port remains on for a certain time and then goes out.
- The blue indicator lamp will go out when the charging plug is connected for a period of time but the charging device is not operated to start charging.
- During charging, the green indicator of the charging port flashes; When the battery level does not reach the limit and the charging device or the power socket stops supplying power, the charging port indicator lamp will remain on for a period of time after turning glue and then go out.
- The purple indicator lamp of the charging port remains on during the AC discharging.
- When the vehicle fails and cannot be charged, the red indicator lamp of the charging port will come on.

### ■ Hongqi brand charging pile

Related functions of timed charging, head unit charging control and remote charging need to be implemented in conjunction with Hongqi brand charging pile.

 **WARNING****■ Precautions for charging**

- Do not insert or pull out the plug with wet hands or standing in water, liquid or snow. Otherwise, it may cause electric shock, resulting in serious personal injury or even death.
- Make sure that there is no water or foreign object in the vehicle socket, charging plug or power plug, and they are not damaged or corroded. Otherwise, it may cause a short circuit, electric shock or even fire, resulting in serious personal injury or even death.
- Do not touch the metal contacts at the charging port, charging plug, and power plug.
- When lightning, do not touch the vehicle or the charging device. Lightning strikes may damage the device and pose a risk of personal injury or death.
- Do not disassemble or modify the charging port and the AC charging cable, otherwise it may cause a fire.
- Do not pull, twist or drag the charging cable.
- Do not place the charging device near high temperature objects.
- While unsupervised, unauthorized persons (for example, children playing) must not touch the charging system or the vehicle.
- When using a household or industrial electrical socket (220 V), it is recommended to use the AC charging cable suggested by FAW. If other charging cables are used for AC charging, it may cause damage to the vehicle or the charging device or even cause a fire.
- Do not use extended cable, cable reel, multiple socket and travel adapter.
- If any part shows signs of damage, wear, breakage, crack or other damage, do not use it.
- When using the charging cable, handle it with care to avoid falling, and do not pull the wire or cable forcefully.
- The power socket and the power supply circuit must be grounded and protected by a special circuit breaker or fuse to avoid danger.
- The AC charging cables for household or industrial electrical sockets (220 V) should use power sockets that meet the requirements of GB1002 and GB 2099.1 standards. It is prohibited to use other sockets.
- If you have any question about the power socket and power supply circuit, please consult a qualified technician.

### **WARNING**

#### ■ **Cases in which electric shock may occur while charging**

- The socket for charging is not grounded.
- Charge in rainy days.

#### ■ **Precautions for use of DC charging connection device**

- Considering that the DC charging plug is heavy and its accidental fall may cause damage to the vehicle and the charging plug or personal injury, please make sure to pull out the charging plug carefully.

### **CAUTION**

#### ■ **During AC discharging**

- The discharge function can be activated when the power battery level is higher than the discharging limit, and deactivated when the power battery level is lower than the discharging limit.
- During AC discharging, the vehicle will automatically terminate AC discharging once the power battery level displayed on the instrument cluster reaches the discharging limit.
- The rated discharge current of the discharge socket is 16 A. When using the AC discharge function, ensure that the total current of the discharge socket does not exceed 16 A.

#### ■ **AC charging electronic lock**

- Before unplugging the charging/discharging plug, make sure that the electronic lock is unlocked, otherwise the charging cable or the vehicle may be damaged.
- While charging in an unattended environment, please lock the charging electronic lock, otherwise the charging cable may be stolen.

#### ■ **Precautions for use of AC charging cable**

- Ensure that the AC charging cable is stored properly and avoid immersion in water.
- Avoid foreign objects from entering the terminal of the AC charging cable plug.
- Avoid stepping on, folding, or knotting cable and wire.
- Avoid using AC charging cable during thunderstorm.
- Avoid using AC charging cable in wet location.
- Do not place heavy objects on the AC charging cable.

 **CAUTION****■ Precautions for charging compatibility**

Hongqi products have been adapted for charging compatibility with mainstream brand charging piles in the market. For an optimal charging experience, it is recommended to choose mainstream brand charging piles for charging.

**■ When dust enters the charging port**

Driving for a long time under extreme dusty road conditions may cause dusts to enter the charging port. An air gun can be used to clean it during vehicle washing or contact the authorized FAW Hongqi dealer for cleaning.

**■ After vehicle collision**

It is forbidden to restart or charge the vehicle.

**■ It is forbidden to connect the AC charging plug and the DC charging plug at the same time, otherwise the charging may be not started or interrupted.****■ Precautions for power battery**

- In daily use, please regularly use charging devices to fully charge the vehicle (it is recommended to fully charge at least once every two weeks).
- When the ambient temperature is too high or too low, the charging time may be prolonged. Long-term charging at too high or low temperature may affect the battery life.
- Do not use high-power DC fast charging method frequently to charge the vehicle, as it can affect the service life of the power battery. It is recommended to give priority to AC charging when conditions are available and time permits.
- To ensure the maximum driving range and the safety of the vehicle when the battery is nearly fully charged, the system will reduce the charging speed, which is normal.
- When the battery temperature is too low, the vehicle will start the battery heating first after connecting with the charging plug, thus the charging start time will be delayed. While charging and heating, the instrument cluster will display "Charging and heating".

## 2-4. Charging/discharging

# Display and setting of charging

### Charging display

- Charging display on instrument cluster

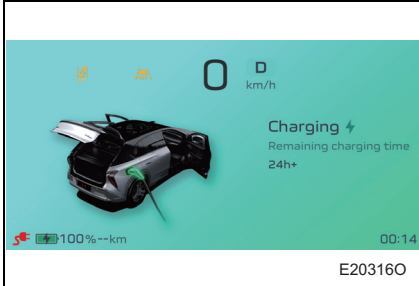

During the charging process, the multi-function display of the instrument cluster will show the remaining charging time, battery level, charging status and other related parameters.

- Charging display on multimedia display

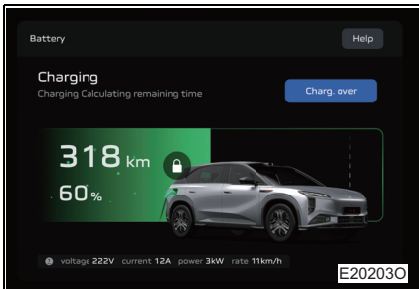

During the charging process, the energy setting interface of the in-vehicle infotainment system will show the remaining charging time, battery level and other related parameters, while also allowing the charging limit, scheduled charging and other functions to be set.

### Charging limit setting

The default custom charging limit in the vehicle is 100%.

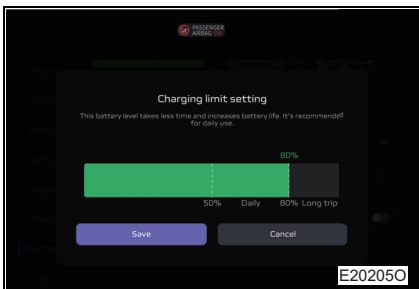

Move the slider on the energy setting interface of the in-vehicle infotainment system to set the charging limit.

The setting range is 50% - 100%, and the setting interval is 5%.

- When the charging capacity is greater than or equal to the charging limit value set by user, the vehicle will stop charging and display "Charging is completed" prompt information.
- During DC charging, when the vehicle displays "Charging completed", if the user sets the charging limit higher than current battery level again at this time, the charging gun needs to be reinserted to start charging again.

## Discharging limit setting

The default custom discharging limit in the vehicle is 20%.

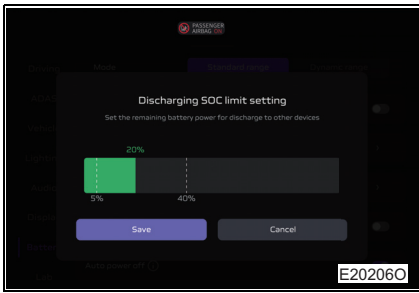

Move the slider on the energy setting interface of the in-vehicle infotainment system to set the discharging limit.

The setting range is 5% - 40%, and the setting interval is 5%.

- After the vehicle is discharged and started, the in-vehicle infotainment system will calculate the remaining discharge time and display "Discharging" simultaneously.
- When the remaining battery level reaches the discharging limit set by the user, the vehicle will stop discharging, and the instrument cluster display will prompt "SOC value is lower than set value, discharging cannot be activated" prompt information.

## AC charging appointment

- Scheduled charging setting

**Step 1** Turn the vehicle power supply to ON mode.



Enable the AC charging appointment function and set the time in the energy settings of the in-vehicle infotainment system.

The scheduled charging switch is OFF by default.

The start time and end time should be separated at least 10 minutes.

**Step 3** When parking the vehicle in an AC charging area, setting the shift lever to P position, applying the EPB, connect the AC charging device, and set the charging pile to start charging. If there is no system fault in the vehicle and the charging device, the vehicle will perform AC charging at the appointed time set by the user.

### ■ Scheduled charging display

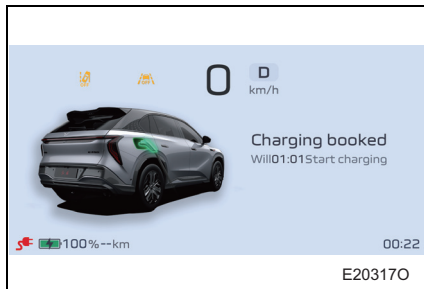

When the time for scheduled charging is not reached, the instrument panel will display the scheduled charging information.

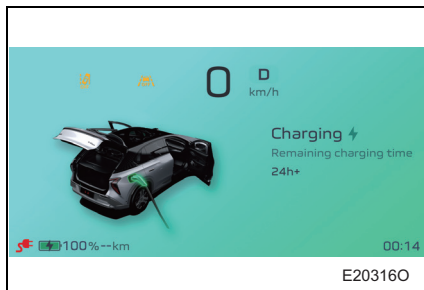

When the time for scheduled charging is reached, the instrument panel will display "Start charging - charging" in turn.



## ■ Head unit charging control

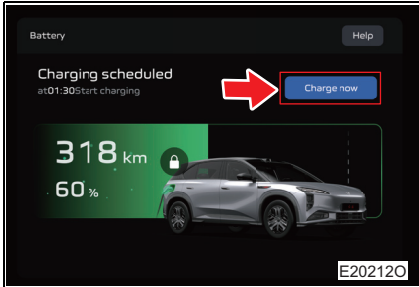

When the vehicle is ready for charging, by touching [Charge now] on the in-vehicle infotainment system energy setting interface, the AC charging can be started immediately without changing the charging mode.

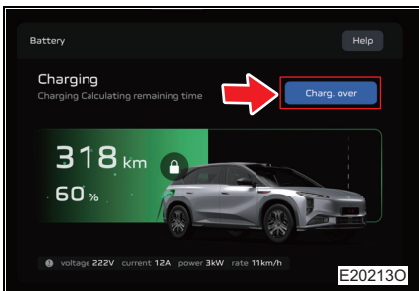

When the vehicle is in charging status, by touching [Charge over] button on the in-vehicle infotainment system energy setting interface, the charging process can stop.

## 2-4. Charging/discharging

# Charging/discharging troubleshooting

Symptom	Possible causes	Solutions
Unable to start charging	Power battery is fully charged or the current SOC of battery is higher than the charging termination SOC limit value	The charging cannot be started when the power battery is fully charged. The charging cannot be started when the current SOC of battery is higher than the charging SOC limit value.
	12 V battery is low	When the 12 V battery power is low, the vehicle control system cannot be started. Please contact the authorized FAW Hongqi dealer.
	Vehicle fault	When the vehicle fails, the charging cannot be started. Confirm whether instrument cluster prompts charging/discharging system fault. If the fault prompt words appears, please stop charging immediately and contact the authorized FAW Hongqi dealer.
	Vehicle not in P gear	Confirm if the vehicle is in trailer mode. If it is in trailer mode, reconnect the charging gun after exiting trailer mode; If it is not in trailer mode, please contact the authorized FAW Hongqi dealer.

Symptom	Possible causes	Solutions
Unable to start AC charging	The charging plug is not reliably connected	Confirm that the AC charging gun is reliably connected to the AC charging socket.
	The AC charging device is not powered	Confirm that the AC charging device is powered. Make sure to start charging in accordance with the instructions of the AC charging device.
	The power socket is not powered	Make sure that the power socket is supplying power. Confirm the indicator lamp status on the cable control box.
	The charging plug is not reliably connected to the power socket	Make sure that the charging plug is reliably connected to the power socket. (Only for cable control box charging)*
	Charging mode is timing mode	Make sure that the charging mode is immediate charging mode.
Unable to start DC charging	The charging plug is not reliably connected	Confirm that the DC charging gun is reliably connected to the DC charging socket. Make sure that the charging connection indicator lamp on the instrument cluster illuminates.
	DC charging device does not match the vehicle charging parameters	If the instrument cluster prompts that the DC charging device does not match the vehicle, please use another DC charging pile for charging.
	DC charging device is not powered	Confirm that the DC charging device is powered. Make sure to start charging in accordance with the instructions of the DC charging device.

Symptom	Possible causes	Solutions
Charging stops during AC charging	AC charging pile stops power output	If the power supply of the power supply device is interrupted, the charging will stop. When the power supply device is restored, the charging must be restarted.
	The power socket stops power output	If the power supply of the power socket is interrupted, the charging will stop. When the power socket is re-powered, the vehicle can automatically resume AC charging.
	The buckle release button on charging gun (vehicle end) is pressed	If the buckle release button on charging gun (vehicle end) is pressed during charging, the charging process will stop
	The charging cable is disconnected	Make sure that the charging cable is reliably connected.
	Charge termination time is reached	In timed charging mode, if the charging termination time is reached, the charging will stop.
	Vehicle fault	When the vehicle fails, the charging cannot be started. Confirm whether instrument cluster prompts charging/discharging system fault. If the fault prompt words appears, please stop charging immediately and contact the authorized FAW Hongqi dealer.

Symptom	Possible causes	Solutions
Charging stops during DC charging	DC charging device and vehicle communication failure	If the instrument cluster prompts that there is a communication failure between DC charging device and vehicle, please reinsert the charging gun and start charging again. If this communication failure occurs several times, please use another charging pile for charging.
	DC charging device stops power supply	If the power supply of the DC charging device is interrupted, the charging will stop. When the DC charging device restores power supply, the charging must be restarted.
	Vehicle fault	When the vehicle fails, the charging will be interrupted. Confirm whether the fault warning lamp on the instrument cluster illuminates. If it does, please stop charging immediately and contact the authorized FAW Hongqi dealer.



**3-1. Key information**

Key ..... 102

**3-2. Opening, closing and locking doors and back door**

Door ..... 105

Back door ..... 111

PEPS ..... 117

**3-3. Loading**

Goods and  
luggage ..... 122

## 3-1. Key information

# Key

### Key

This vehicle comes with the following keys.

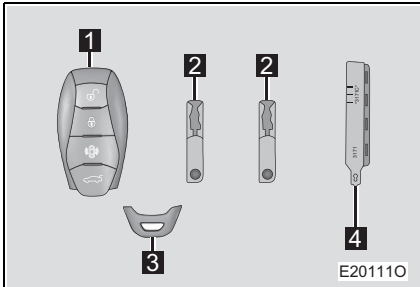

#### 1 Smart key

- Operate the PEPS system (See P.117)
- Operate the wireless remote control function

#### 2 Mechanical key

#### 3 Key end cover

#### 4 Key number plate

### Wireless remote control

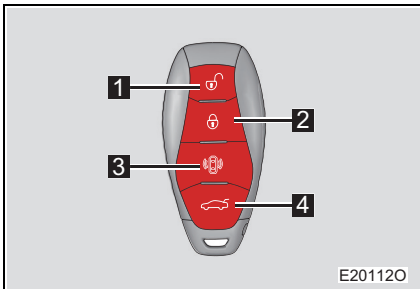

#### 1 Unlock button

Press the button to unlock the doors; press and hold the button to open all windows.

#### 2 Lock button

Press the button to lock the doors; press and hold the button to close all windows.

#### 3 Vehicle locating button

When the entire vehicle is locked, press the vehicle locating button to trigger the vehicle locating function. The turn signal lamp will flash 3 times accompanied by the horn sounding 3 times.

#### 4 Back door opening/closing button

Press and hold the button to open/close the back door.



## Using mechanical key

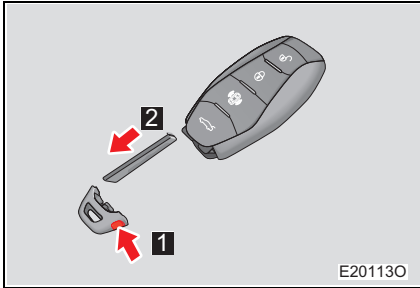

- 1 Press the unlock button to detach the key end cover
  - 2 Taking out the mechanical key
- After using the mechanical key, store it in the smart key. Always carry the mechanical key with the smart key. If the smart key battery runs out and does not work properly, use the mechanical key. (See P.359)

### ■ When you need parking service

Be sure to keep the mechanical key with you, and only give the smart key to the parking service personnel.

### ■ Key number plate

Please keep the key number plate in a safe place and keep it properly.

### ■ When traveling by air

When flying with the smart key, make sure that you don't press any button on the smart key while in the cabin. If the key is placed in the bag, make sure that no buttons on the key are accidentally pressed. Pressing any button may cause the key to emit radio waves, thus interfering with the flight of the aircraft.

### ■ Key battery power

- The standard battery life is 1 to 2 years.
- Even if the key is not in use, the battery may be depleted. The following symptoms indicate that the key battery is low or may be depleted. Replace the battery if necessary. (See P.410)
  - The PEPS system or wireless remote control function does not work.
  - The detection area becomes smaller.
  - The instrument cluster displays that the key battery is low.
- To avoid serious degradation of key performance, do not place it within 1 m of the following electrical equipment that can generate magnetic field:
  - TV set
  - Personal computer
  - Mobile phone, cordless phone and battery charger
  - Mobile phone or cordless phone being charged
  - Table lamp
  - Induction cooker

### ■ Replacing battery

(See P.410)



#### CAUTION

##### ■ Prevent damage to the key

- Do not subject the key to violent impact or expose it to high temperature (such as direct sunlight) and humid environment.
- Do not wet the key or clean it in ultrasonic cleaner.
- Do not immerse the key in water.
- Do not attach metal or magnetic materials to the key, or place the key near such materials.
- Do not disassemble the smart key.
- Do not stick labels or other items on the key surface.
- Do not place the key near objects that can generate magnetic fields, such as television, sound system, induction cooker or electronic medical equipment (such as low-frequency medical equipment).
- Do not place the smart/card key near the wireless charging area where the mobile phone is being charged.

##### ■ Carry the smart key with you

When carrying the key with you, keep it 10 cm or more away from the electrical equipment that are turned on. Radio waves emitted by electrical equipment within 10 cm from the key may interfere with the key, causing it to fail to work normally.

##### ■ When the PEPS system fails or there is other failure related to the key

Please send the vehicle to an authorized FAW Hongqi dealer with all the keys of the vehicle.

##### ■ When the key is lost

If the key is lost, the risk of vehicle theft will obviously increase. Please go to an authorized FAW Hongqi dealer with all the keys of the vehicle for re-matching.

When the smart key is lost, do not match the key at non-authorized FAW Hongqi dealer to avoid the loss of critical anti-theft information of the vehicle and increasing the risk of vehicle theft.

## 3-2. Opening, closing and locking doors and back door

# Door

### Unlocking/locking doors from outside

#### ■ PEPS

As long as you carry the smart key with you, the door can be unlocked and locked through PEPS function.

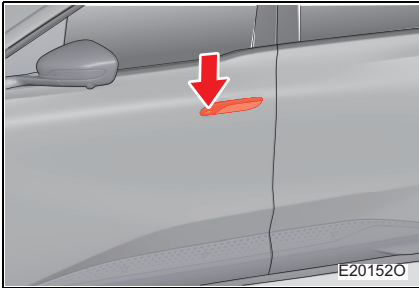

Turn off the vehicle power supply and close all doors, then touch the door handle sensing switch to lock the door.

When any door is not closed, it is impossible to lock the door by touching the door handle sensing switch.

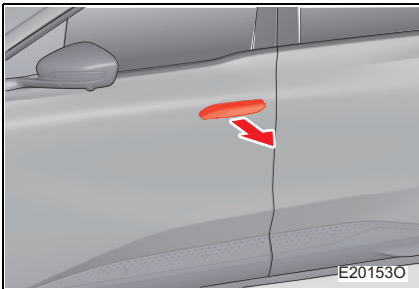

When vehicle is locked, touch the door handle sensing switch to unlock door and eject door handle.

#### ■ Wireless remote control

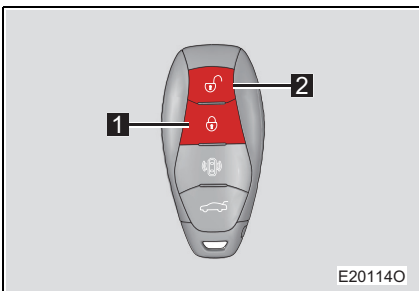

**1** Locking all doors

**2** Unlocking driver's door/all doors

See P.191 for unlocking mode

■ Mechanical key

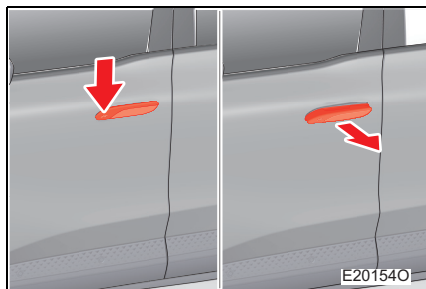

Press the front of driver's door handle to raise it, then pull the middle part and pull it out vertically.

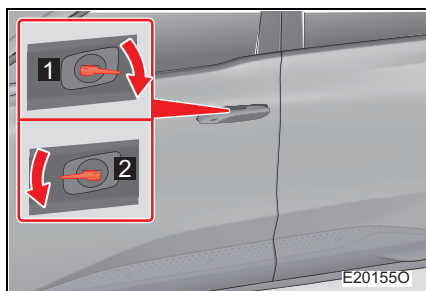

Hold the door handle, lock and unlock the door with a mechanical key.

1 Locking driver's door

2 Unlocking driver's door

■ The key battery runs out of power

If the key battery runs out of power, replace the battery with a new one. (See P.410)

Unlocking/locking doors from inside

■ Central locking switch

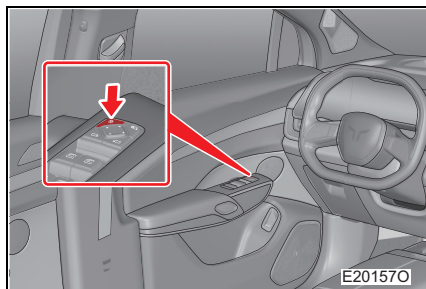

Press the central locking switch on the driver's door to unlock the doors when the doors are locked, and press it again to lock the doors.

Note: When a door is not closed, the central locking switch can only unlock the doors.

### ■ Door inside button

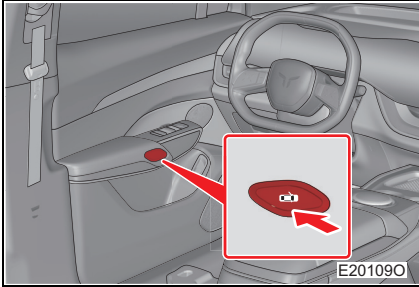

When the vehicle speed is less than 3 km/h, press door inside button to open the doors.

### ■ Door inside handle

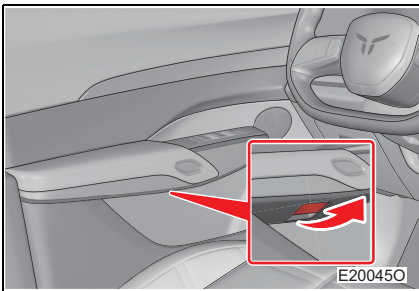

When the door inside button is invalid, pull the door inside handle to open the door.

## Rear door child safety lock

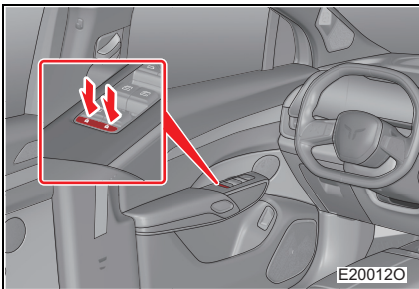

After the safety lock is set through this switch, the rear door and window on the corresponding side cannot be operated from inside.

Set the safety lock to prevent children from opening the rear doors and operating the window from inside.

### ■ **Speed sensing door lock function**

- When all doors are closed with any door unlocked, and the vehicle runs at a speed of about 15 km/h, the speed sensing door lock will be activated to lock the doors.

### ■ **Concealed door handle**

- When vehicle is unlocked through PEPS function or central locking switch, all door handles will eject.
- When vehicle is unlocked through remote control key, driver side door handle/all door handles will eject according to the set safety unlock mode.
- When the vehicle is running and vehicle speed exceeds approx. 15 km/h, all door handles will retract.
- When vehicle is locked through PEPS function, remote control key or central locking switch, all door handles will be retract.
- When unlocking/locking continuously and quickly, in order to prevent the handle motor from overheating, all door handles will enter the protection status after operating 6 times. The protection status will last for 20 seconds. After the protection status is released, the door handle can work normally.

### ■ **Conditions affecting PEPS system or wireless remote control**

(See P.119)

**WARNING**
**■ Prevent accidents**

Please observe the following precautions when driving.

Otherwise, occupants may be thrown out of the vehicle due to the accidental opening of the door, resulting in serious personal injury and even death.

- Be sure to fasten the seat belt properly.
- Ensure that all doors are closed correctly.
- Be sure to lock all doors.
- Do not press the door inside button while driving.

Otherwise, occupants may be thrown out of the vehicle due to opening of the door, resulting in serious personal injury and even death.

- If there are children in the rear seat, be sure to set the rear door child safety lock.
  - When leaving the vehicle and there is no one in the vehicle, please take the key with you, close all windows and lock all doors to prevent others from entering or stealing the vehicle.
  - When leaving the vehicle, please carry the smart key. If the key is left inside the vehicle and the vehicle battery is depleted, doors cannot be opened.
  - This vehicle uses an electrically operated door lock. If the vehicle battery is depleted, the door lock may not work normally.
  - Never leave children unattended in the vehicle.
  - Do not allow children to carry or use the key, as children may cause a safety hazard by starting the vehicle or operating the shift lever.
  - Do not allow children to play with windows or other equipment as they may get injured.
  - Make sure that the temperature inside the vehicle is appropriate, because too high or too low temperature will cause fatal injury to children.
  - Make sure that the surrounding area of the vehicle is safe when opening the door.
- It is very dangerous to open the door suddenly, which may hit other vehicles or pedestrians and cause accidents.
- After closing the door, make sure it is closed tightly.

It is very dangerous to leave the door ajar, because the door may open accidentally during driving, which may cause an accident.

 **WARNING**

■ **When using concealed door handle**

- Be careful not to get caught by the door handle or damage the door handle.
- When the door handle ejects, make sure that there is no foreign matter around it to prevent damage.
- When driving in winter, remove the ice or snow from the door handle, and then unlock or lock the door, otherwise the door handle may not work properly.



## 3-2. Opening, closing and locking doors and back door

### Back door

The back door can be opened using the back door unlocking button, PEPS or wireless remote control.

#### Back door is opened

##### ■ Opening back door from inside

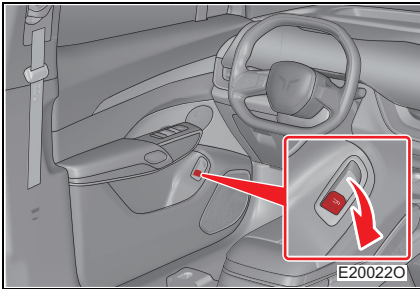

When the vehicle is stationary and the back door is closed, pull up the back door interior unlocking button to unlock and open the back door.

##### ■ Opening back door from outside

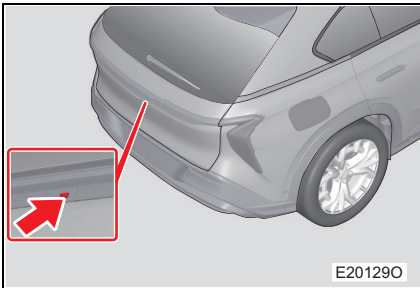

When the vehicle is locked, carry the smart key with you, and press the back door exterior unlocking button to unlock and open the back door; When the vehicle is unlocked, press the back door exterior unlocking button to unlock and open the back door.

##### ■ Wireless remote control

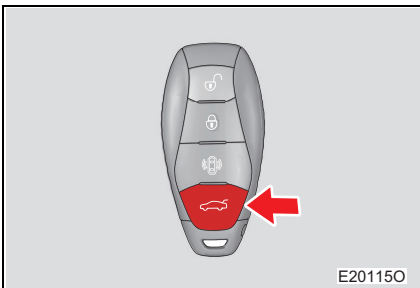

When the back door is closed, press and hold button to unlock and open the back door.

### ■ Trunk projection opening\*

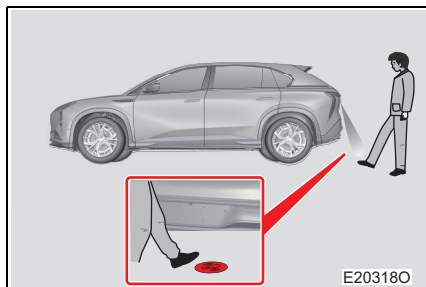

When the kick projection switch in the in-vehicle infotainment system is turned on (see P.190), carrying the smart key near the vehicle will activate the trunk projection. At this time, stepping on the ground projection area will cause the projection cursor to blink, allowing the back door to unlock and open.

### ■ When using trunk projection opening function

- When stepping, the upper part of the shoe should cover the whole projection area with a significant stepping action.
- When stepping, the foot should remain on the ground for more than 0.5 second without significant movement.
- The projection cursor displays different brightness levels during the day and night.
- A dirty lens may cause stepping to fail and the projection to blink, be sure to clean the projection lens at this time.
- When the 12 V vehicle battery is too low, the trunk projection function may not be enabled.

## Closing back door

### ■ Closing back door from outside

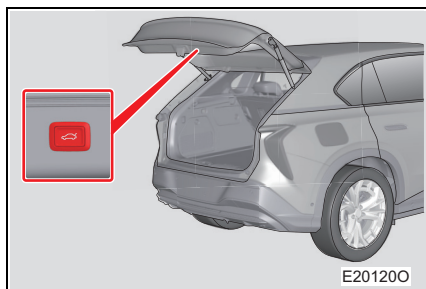

Press the back door closing button, the back door will automatically be closed.

### ■ Closing back door from inside

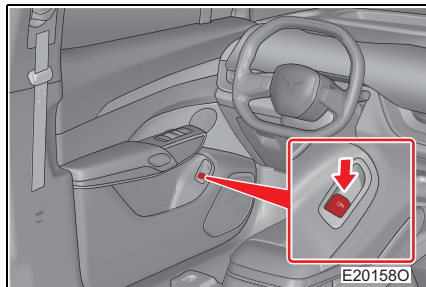

When the vehicle is stationary and the back door is opened, press and hold the back door interior unlocking button until the back door is closed.

### ■ Wireless remote control

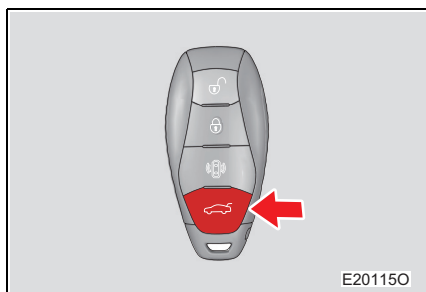

When the back door is open, press and hold the button until the back door is closed.

### ■ Trunk projection closing \*

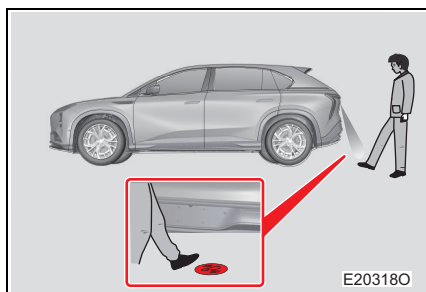

When the back door is opened, the kick projection switch in the in-vehicle infotainment system is turned on (see P.190), carrying the smart key near the vehicle will activate the trunk projection. At this time, stepping twice on the ground projection area with one foot will cause the projection cursor to blink, allowing the back door to close.

---

### ■ When using trunk projection closing function

- When stepping, the upper part of the shoe should cover the whole projection area with a significant stepping action.
- When stepping, the foot should remain on the ground for more than 0.5 second without significant movement.
- The interval between two stepping should be less than 2 seconds.
- The projection cursor displays different brightness levels during the day and night.
- A dirty lens may cause stepping to fail and the projection to blink, be sure to clean the projection lens at this time.
- When the 12 V vehicle battery is too low, the trunk projection function may not be enabled.

---

### ■ Trunk lamp

When the back door is opened, the trunk lamp will come on.

### ■ During the back door opening process, press the back door interior unlocking button to stop opening. Pull it up again to resume opening.

### ■ Position memory of back door

Open the back door, adjust the back door to an appropriate angle (which should be more than half of the maximum opening angle), press and hold the back door closing button for more than 3 seconds, then all turn signal lamps will flash once and the current position will be memorized as the opening position of trunk.

### ■ Key reminder

With vehicle power supply set to OFF mode and the vehicle locked, when the back door is opened and closed separately from outside, if the smart key is left in the trunk, the key reminder will be triggered (the back door will be automatically opened).

 **WARNING**

- **When opening and closing the back door, be careful to avoid being caught by the back door.**
- **Before driving**
  - Make sure the back door is fully closed. Otherwise, the back door may open accidentally and knock into the objects nearby, or the objects in the trunk may be thrown out during driving, causing an accident.
  - Prevent the children from playing in the trunk. Otherwise, they may be locked in the trunk by accident and suffer from heatstroke, suffocation or other injuries thereafter.
  - Do not allow children to open or close the back door. Failure to do so may cause the back door to open by accident or cause the closing back door to pinch the child's hands, head or neck.
- **Precautions when driving**

Be sure to keep the back door closed to prevent objects from being thrown out.
- **When children are in or around the vehicle**

Prevent children from playing in or around an unattended vehicle, especially when the back door has been opened, because children may enter and be trapped in the trunk. If the temperature in the vehicle is too high or too low at this time, serious injury or death may occur.
- **Important when driving**

Never let anyone sit in the trunk. Otherwise they are susceptible to serious injury or even death in the event of emergency braking or collision.
- **Anti-pinch function**

Do not activate the anti-pinch function by intentionally stopping the moving window with any part of your body.

 **WARNING**

■ **Using trunk**

Please observe the following precautions. Otherwise a body part may be pinched, causing serious injury.

- Before opening the back door, remove the heavy load on the back door, such as snow and ice. Otherwise, it may cause the back door to suddenly close again after being opened.
- When opening or closing the back door, thoroughly check the surrounding area for safety.
- If anyone is nearby, ensure their safety and inform them that the back door is about to open or close.
- Use caution when opening or closing the back door in windy weather, because the back door may suddenly move in strong winds.
- Do not install any accessories on the back door. Otherwise, the extra load on the back door may cause the back door to suddenly close again after being opened.

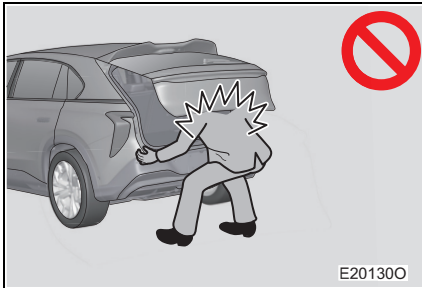

- It is much more difficult to open or close the back door on a slope than on a level road, so beware of accidental closure of the back door during opening or accidental opening during closing. Before using the trunk, make sure that the back door is fully opened and secured.

- When closing the back door, special care should be taken to avoid pinching fingers and other body parts.
- Do not touch the back door during its electric operation (opening/closing), to prevent personnel injury or damage to the back door.
- If the automatic opening or closing process of the back door is affected by poor movement or obstacles, the opening or closing process will be interrupted automatically:
  - Check if there are obstacles in the opening or closing path of back door;
  - The back door can be continued to open or close manually if necessary. Greater force is required for this purpose, and force must be applied slowly; Do not operate the back door violently at this time to prevent damage to the back door from excessive impact.

## 3-2. Opening, closing and locking doors and back door PEPS

As long as you carry the smart key with you, for example, in your pocket, you can do the followings. (The driver must carry the key with him)

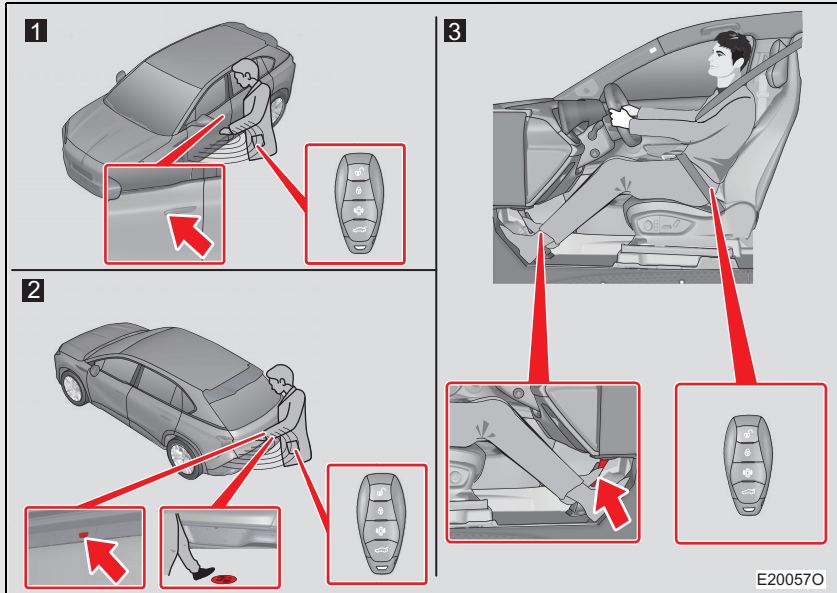

Note: This illustration is shown for smart key only.

- 1 Door locking/unlocking. (See P.105)
- 2 Locking and unlocking the back door. (See P.111)
- 3 Start the vehicle. (See P.226)

■ Effective range (the area where the key can be detected)

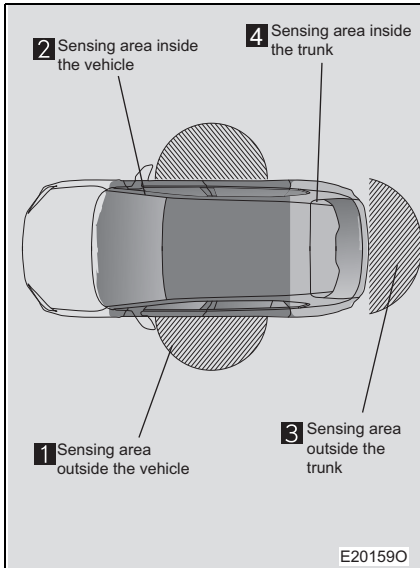

Effective range of key sensing antenna:

A hemispherical area centered on the sensing antenna.

**1** When locking or unlocking the door

When the key is in the sensing area outside the vehicle, you can lock or unlock the door.

**2** When starting the power system or switching the vehicle power supply mode

If the key is in the sensing area inside the vehicle, you can start the power system or switch the vehicle power supply mode.

**3** When unlocking the trunk lid

When the key is in the sensing area outside the trunk, if the conditions are met, you can unlock the trunk lid.

**4** When the key is left in the trunk

If the back door is closed when the key is in the sensing area inside the trunk, and the conditions are met, the key reminder will be activated. (See P.114)



### ■ Warning and prompt function

The system warning and prompt functions are realized through the instrument cluster, warning buzzer and hazard warning lamp.

- When any warning lamp comes on

Take corresponding measures depending on the lit warning lamp. (See P.61)

- When an warning message is displayed

Take corresponding measures depending on the warning message displayed by the instrument cluster.

### ■ Conditions affecting operations

The radio waves used in the PEPS system are weak. The communication between the key and the vehicle may be affected in the following circumstances, which may prevent the PEPS system and the wireless remote control from working properly.

- When the key battery is low.
- When the key battery is depleted
- When the user is close to a TV tower, power plant, gas station, radio station, large monitor, airport or other facilities that produce strong radio waves or electrical noise interference.
- When the user carries a portable radio, mobile phone, cordless phone or other wireless communication device.
- When the key comes into contact with or is covered by a metal object.
- When multiple smart keys are near the vehicle at the same time.
- When the user carries or uses the key with the following device that emit radio waves.
  - Smart key of any other vehicle
  - Wireless remote control key for transmitting radio waves
  - Personal computer
- When the sunshade film with metal composition or any metal material is adhered to the rear windshield.
- When the following metal objects touch or cover the key.
  - A card with aluminum foil
  - Cigarette case with aluminum foil attached inside
  - A wallet or bag made of metal
  - Coins

- Metal hand warmer
- Media such as CD and DVD
- There are other wireless remote control keys (transmitting radio waves) near the vehicle when they are in use.
- When the key is near the battery charger or electronic device.

### ■ Operating system properly

- Remember to carry the key with you when operating the system. When operating outside the vehicle, do not make the key too close to the vehicle.
- Depending on the specific location of the key and the holding method, the key signal may not be detected, resulting in the system not functioning properly.

### ■ Safety function

- When using remote unlocking or intelligent unlocking, if the door or back door is not opened, the vehicle will be automatically locked after a period of time.

### ■ When parking for a long time

- To prevent the vehicle from being stolen, do not place the key too close to the vehicle.
- When the vehicle is parked for a long time, it must be locked. Otherwise, the battery may be depleted.

### ■ If the PEPS system does not work properly

- Lock and unlock the door: Use the mechanical key. (See P.359)
- Start the power system. (See P.360)

### ■ Comments on PEPS

- Under the following circumstances, the system may not work properly even if the key is within the effective range (sensing area).
  - When locking or unlocking the door, the key is too close to the window or door handle, too close to the ground or too high.
- As long as the smart key is within the effective range, anyone can lock or unlock the door. Please keep the key properly.
- The PEPS may fail if a large amount of water splashes on the door handle (such as during vehicle washing or heavy rain).
- The door may not be locked under the following circumstances.

- When the smart key is still in the vehicle and the door is locked with the intelligent locking function.
- When any door is not completely closed.

**WARNING****■ Precautions for interference with electronic devices**

People who use implantable pacemakers, cardiac resynchronization therapy pacemakers or implantable cardioverter defibrillators should keep an appropriate distance from the antenna of the PEPS system.

- Radio waves may affect the normal operation of such devices. For details of radio wave frequency and radio wave transmission time, please consult authorized FAW Hongqi dealer. Then ask your doctor if you can use them normally.
- People who use other electronic medical devices instead of implantable pacemakers, cardiac resynchronization therapy pacemakers or implantable cardioverter defibrillators should consult the device manufacturer about the impact of radio waves on the operation of the devices.
- Radio waves may have an unpredictable impact on the use of such medical devices.
- For details about PEPS, please consult authorized FAW Hongqi dealer.

## Goods and luggage

**Please pay attention to the followings when storing goods and luggage.**

- Store goods and luggage in the trunk as much as possible.
- Ensure that all articles are firmly fixed.
- Keep the vehicle level. Put the weight forward as far as possible to keep the vehicle balanced.
- In order to improve the driving range, please do not carry unnecessary heavy objects.

 **WARNING****■ Articles prohibited from being stored in the trunk**

The following articles may cause fire when placed in the trunk.

- A container with gasoline.
- Aerosol can.
- Other inflammable and explosive articles.

**■ Precautions for storage**

To avoid serious personal injury or even death, please observe the following precautions:

- Do not place goods or luggage in the following places. Otherwise, the articles may jam the brake pedal or accelerator pedal which may not work properly, and may block the driver's sight or hit the driver or passengers, thus causing accidents.
  - Driver's footwell
  - Front passenger's seat or rear seat (with articles)
  - Instrument panel
- Store all the articles properly in the vehicle. Otherwise, the articles may move and cause personal injury in the event of an accident or emergency braking.
- It is forbidden to store poorly sealed liquid containers in the trunk.

**■ Load and distribution**

- Please do not overload the vehicle.
- Be sure to place the goods evenly.  
Improper placement may lead to poor steering or braking control performance, resulting in serious personal injury and even death.
- Do not put heavy objects in the trunk for a long time.  
Placing heavy objects in the trunk for a long time may affect the performance of the suspension system.



**4-1. Seats**

Front seat ..... 126  
 Rear seat ..... 128  
 Rear headrest ..... 131  
 Seat memory ..... 133  
 Seat temperature control\* ..... 135  
 Seat massage function\* ..... 137

**4-2. Steering wheel and rearview mirror**

Steering wheel ..... 138  
 Anti-glare interior rearview mirror ..... 141  
 Exterior rearview mirror ..... 142

**4-3. Windows**

Power window ..... 146

**4-4. A/C system**

Automatic A/C system ..... 148  
 Rear windshield heating ..... 162

**4-5. Interior power supply**

On-board wireless charging ..... 163  
 Power outlet ..... 165

**4-6. Interior lamp**

Using interior lamp ..... 167

**4-7. Storage compartments**

Storage compartments list ..... 170

**4-8. Other equipment**

Using other equipment ..... 177

# 4-1. Seats

## Front seat

### Adjustment steps

#### ► Driver's seat

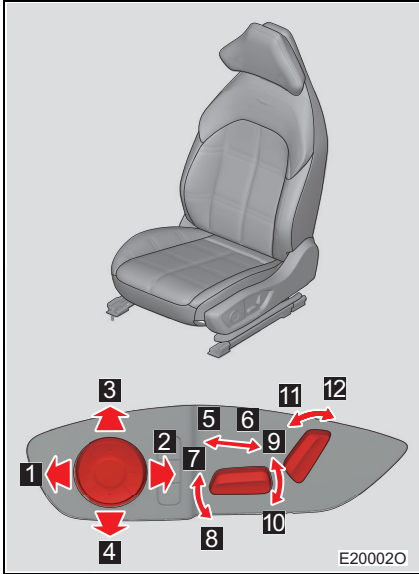

- 1 Protruding lumbar support
- 2 Depressing lumbar support
- 3 Moving lumbar support upward
- 4 Moving lumbar support downward
- 5 Moving seat forward
- 6 Moving seat backward
- 7 Lifting front end of seat
- 8 Lowering front end of seat
- 9 Lifting seat
- 10 Lowering seat
- 11 Tilting seat back forward
- 12 Tilting seat back backward

#### ► Front passenger's seat



- 1 Protruding lumbar support
- 2 Depressing lumbar support
- 3 Moving lumbar support upward
- 4 Moving lumbar support downward
- 5 Moving seat forward
- 6 Moving seat backward
- 7 Lifting seat
- 8 Lowering seat
- 9 Tilting seat back forward
- 10 Tilting seat back backward



 **WARNING**
**■ Seat adjustment**

- Do not tilt the seat excessively during driving, so as to prevent your body from slipping out of the lap belt. If the seat is tilted excessively, the lap belt may slide over the hips and strangle the abdomen or allow the shoulder belt to reach the neck, increasing the risk of serious injury or even death in the event of an accident.
- Make sure the seat adjustment components are locked in place. Failure to securely lock the adjustable seat and seat back is extremely dangerous. In case of emergency braking or collision, the seat or seat back can move unexpectedly, resulting in personal injury. Try to slide the seat forward and backward and shake the seat back to make sure the seat is locked in place.
- Do not place your hands under the seat or near moving parts, as the seat mechanism may pinch your hands.
- Be careful when adjusting the seat position to ensure that other occupants are not injured when the seat moves.
- Do not allow the children to adjust the seat.  
It is very dangerous to allow children to adjust the seat. If a child's hand or foot is caught, serious injury could occur.
- Always park the vehicle before adjusting the driver's seat.  
Adjusting the driver's seat during driving is very dangerous, because the driver may lose control of the vehicle, which could lead to an accident.

**■ Seat modification**

- Modifying or replacing the front seats may damage the airbag components in the seats and cause failure of the airbags to deploy properly in the event of a crash.
- If the seat needs to be removed or replaced, please contact an authorized FAW Hongqi dealer.

**■ If the seat is damaged**

- If the seat has been damaged, it is very dangerous to drive the vehicle at this time.
- After a collision, even if the seat airbag does not deploy, the seat may be damaged. Therefore, after a collision, please contact an authorized FAW Hongqi dealer for inspection of the seats, seat belt pretensioners and airbags.

## 4-1. Seats

### Rear seat

The rear seat back is folding.

#### Rear seat back angle adjusting and folding

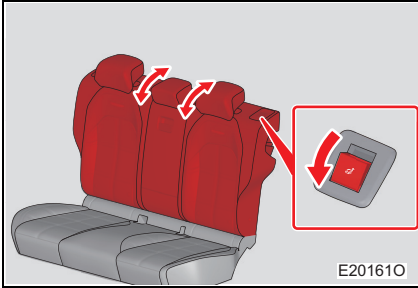

Pull the release handles on the left and right sides of rear seat to adjust the angle of seat back and fold it.

#### Resetting the seat back to the upright position

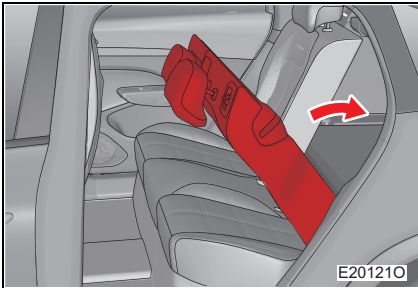

Reset the seat back to the upright position until a "click" is heard, and then gently shake the seat back back and forth to ensure it is securely locked.

Check that all seat belts are properly secured for use.

**⚠ WARNING**

**■ Precautions during rear seat back folding**

Please observe the following precautions. Failure to do so may result in serious injury or even death.

- Do not fold the seat backs while driving.
- Park the vehicle on a level ground, set the shift lever to P position, and apply the parking brake.
- When folding the rear seat backs, be careful not to pinch your hands.
- Before folding the rear seat backs, adjust the position of the front seats so that the front seats do not interfere with the rear seat backs during folding of the rear seat backs.

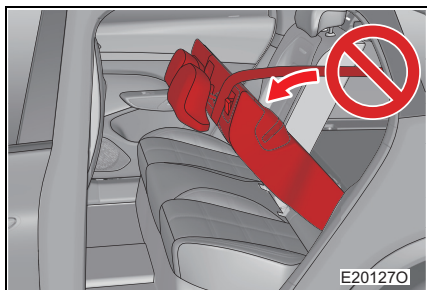

- Before reclining the rear seat backs, be sure to release the rear seat belt buckles and retract the belts of both outboard rear seats to both sides of the seats; otherwise the seat belts, buckles and seat backs may be damaged.

**■ Precautions after rear seat back folding**

- Do not allow anyone to sit on the folded seat back or in the trunk while driving.
- Do not allow a child to enter the trunk.

It is very dangerous for children to play in the vehicle with the seat back folded down. If a child enters the trunk and the seat back is folded back, the child could be trapped in the trunk, leading to an accident.

- Securely fix items in the trunk.

It is very dangerous to drive without securely fixing items and luggage, because they may move and interfere with driving in case of emergency braking or accidental collision.



**WARNING**

■ **Precautions after resetting the seat back to the upright position**

Please observe the following precautions. Failure to do so may result in serious injury or even death.

- Gently shake the seat back slightly forward and backward to make sure it is securely locked in place.
- Check that the seat belts are not twisted or stuck under the seats.

# Rear headrest

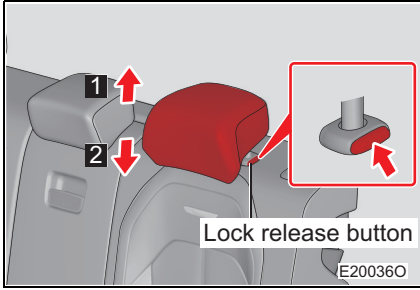

**1 Moving up**

Pull up the headrest while pressing and holding the lock release button.

**2 Moving down**

Push down the headrest while pressing and holding the lock release button.

■ Removing headrest

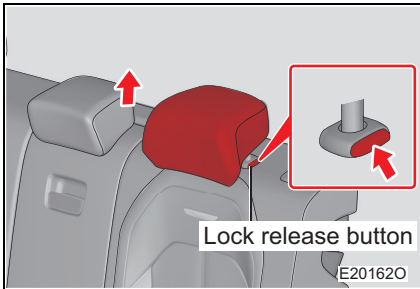

Pull up the headrest while pressing the lock release button.

■ Adjusting headrest height

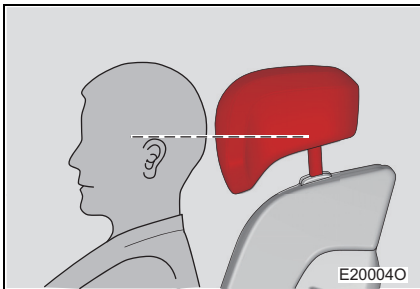

Adjust the headrest so that the center of the headrest is flush with the upper end of ears.



**WARNING**

■ **Precautions for headrest**

Please observe the following precautions for headrest. Failure to do so may result in serious personal injury or even death.

- Use the headrests specifically designed for the seats.
- Be sure to adjust the headrest to the appropriate position for use.

■ **Headrests can reduce the whiplash effect and mitigate the neck injury of the occupants in case of a rear impact.**

# Seat memory

**The position of the seat, steering wheel and exterior rearview mirror can be memorized at the same time.**

## Seat memory setting

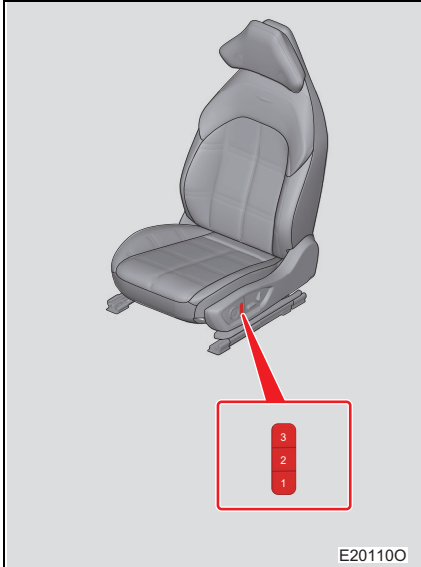

To set the memory content: After adjusting the position of the seat, steering wheel and exterior rearview mirror, press and hold any memory button (for more than 3 seconds). Release the button after hearing the prompt tone, and the position information will be memorized in that button.

To recall the memory content: Press the memory button to automatically adjust the seat, steering wheel and exterior rearview mirror to the memorized position set by the button.

4  
Comfort adjustment

### Initialization setting

Vehicle power supply is set to ON mode, and long press buttons 1 and 3 to perform initialization setting. Release the button after hearing the prompt tone, the seat, steering wheel and rearview mirror position memories are initialized successfully.

Vehicles equipped with electric steering wheel adjustment need to perform position self-learning of the steering wheel after position memory initialization, otherwise the steering wheel position memory, recall and welcome functions will fail. Operate the steering wheel adjustment switch to move the steering wheel to its limit position in a certain direction, do not release the switch and hold it for 2 seconds to complete self-learning for that direction. Repeat the above operation for the remaining three directions to complete self-learning.

### Welcome function

The welcome function includes automatic backing and automatic return.

**Automatic backing:** Turn off the vehicle power supply, and open the left front door. Then the seat and steering wheel automatically moves backward to facilitate the driver to get off the vehicle.

**Automatic return:** After doors are closed, the brake pedal is depressed or the driver has fastened the seat belt, the seat and steering wheel will automatically return to their positions before the driver leaves the vehicle.

---

#### ■ **Welcome function switch**

The welcome function can be turned on and off through the vehicle settings interface of the in-vehicle infotainment system. (See P.190)

#### ■ **During automatic backing**

During the automatic backing, the driver can operate the steering wheel adjusting switch, seat adjusting switch or seat memory button to terminate the steering wheel and/or seat backing.

#### ■ **During automatic return**

During the automatic return, the driver can operate the steering wheel adjusting switch, seat adjusting switch or seat memory button to terminate the steering wheel and/or seat return.



## 4-1. Seats

# Seat temperature control\*

The temperature of each seat can be adjusted separately.

### ■ Front seat temperature adjustment



Method 1: Touch the seat heating and ventilation button on the seat setting interface of multimedia display to select appropriate heating and ventilation level.

Levels 1-3 are selectable.

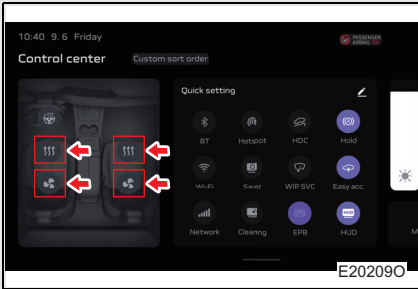

Method 2: Touch the seat heating and ventilation button on the shortcut menu interface of multimedia display to select appropriate heating and ventilation level. (See P.183)

Levels 1-3 are selectable.

### ■ Rear seat temperature adjustment

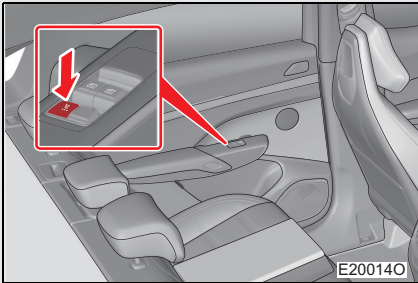

Touch the seat heating button, the indicator lamp will illuminate and the rear seat heating function will be activated; touch the button again, the rear sea heating function will be deactivated.

Levels 1-3 are selectable.

### ■ Operating conditions

Vehicle power supply is set to ON mode.

 **WARNING**

■ **Be sure to observe the following precautions when using seat heating or ventilation function**

- Use caution when following persons are seating on the heated seat to avoid burns:
  - Infants, children, the elderly, the sick and the disabled
  - Persons with sensitive skin
  - Persons who are very fatigued
  - Persons who are drowsy because of taking alcohol or drugs (sleeping pills, cold medicine, etc.)
- Do not cover the seat with any object (e.g. blanket, seat cushion) when using seat heating or ventilation. Otherwise, the seat temperature will increase or decrease, which leads to overheating or overcooling.
- Do not turn on the seat heating or ventilation function unless necessary. Otherwise, passengers may feel overcooled, overheated or suffer from local burns.

 **CAUTION**

■ **Preventing damage to seat heating or ventilation system**

Do not place heavy objects with uneven surfaces on the seats, or stick sharp objects (needles, nails, etc.) in the seats.

■ **When cleaning seats**

Do not clean the seats with organic substances such as benzene, gasoline, etc. Otherwise, the heater and seat upholstery are liable to be damaged.

# Seat massage function\*

The driver seat massage function can be realized through multimedia display.



Seat massage mode and level can be selected through seat setting interface of multimedia display.

The system will be turned off automatically after a period of operation.

## ■ Operating conditions

Vehicle power supply is set to ON mode.

### **WARNING**

#### ■ Using seat massage function

- Pregnant women, puerpera or sick people (heart disease, etc.) who need rest should consult a doctor before use.
- Children are forbidden to use massage function.
- The massage function should not be used immediately after a meal or used for a long time.
- If you feel uncomfortable when using massage function, stop using it immediately.

## 4-2. Steering wheel and rearview mirror

# Steering wheel

### Steering wheel adjustment

The steering wheel can be adjusted to a comfortable position.

#### ■ Electrical adjustment\*

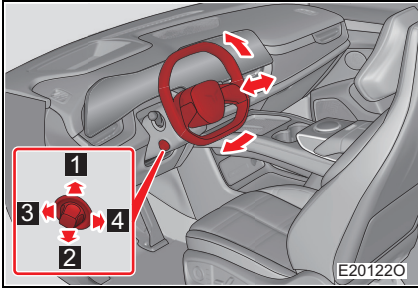

- 1 Move upward
- 2 Move downward
- 3 Move forward
- 4 Move backward

#### ■ Mechanical adjustment\*

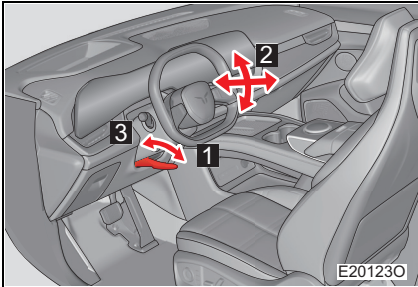

- 1 Release the steering wheel adjusting handle.
- 2 Adjust the steering wheel to a comfortable position.
- 3 Lock the steering wheel adjusting handle.

### Steering wheel heating\*



#### Method 1:

Touch the steering wheel heating button on the seat setting interface of multimedia display, the button will illuminate and the steering wheel heating function will be activated, touch the button again, the steering wheel heating function will be deactivated.

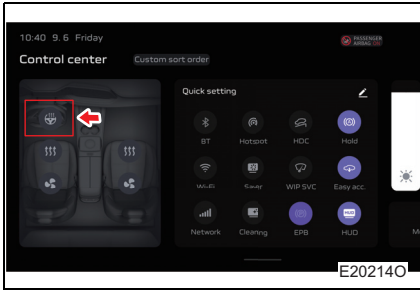

Method 2:

Touch the steering wheel heating button on the shortcut menu interface of multimedia display.

(See P.183)

## Horn

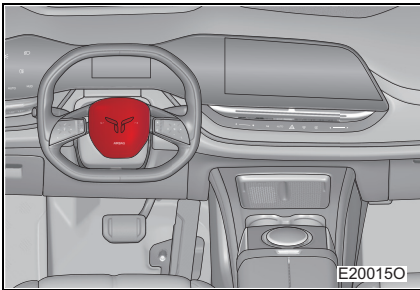

Press the horn symbol or the surrounding area to sound the horn.

### **WARNING**

#### ■ **Precautions when driving**

- Do not adjust the steering wheel while driving, as this may cause the driver to make a mistake and cause an accident, which could result in serious injury or even death.
- During driving, the driver's hands should hold the outside of the steering wheel rim at the 3 o'clock and 9 o'clock positions. Do not hold the steering wheel at the 12 o'clock position or in any other position, as this may result in injury to the driver's arms or head when the driver's airbag deploys.

#### ■ **When adjusting the steering wheel**

The steering wheel should be adjusted so that the driver's chest is at least 300 mm away from the steering wheel. Do not make the steering wheel directly face the driver's face; otherwise the driver's airbag will not provide effective protection in the event of an accident.

#### ■ **After adjusting the steering wheel mechanically**

Ensure that the steering wheel is firmly locked, otherwise it may cause an accident due to sudden movement of the steering wheel, resulting in serious personal injury or even death.

## 4-2. Steering wheel and rearview mirror

# Anti-glare interior rearview mirror

### Adjusting interior rearview mirror

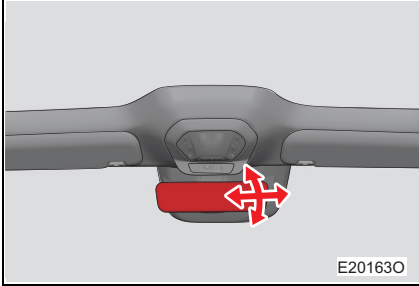

The interior rearview mirror can be adjusted up, down, left or right depending on the driving posture.

The driver must adjust the interior rearview mirror to a proper position, in order to view the rear of the vehicle through the rear windshield.

### Anti-glare function

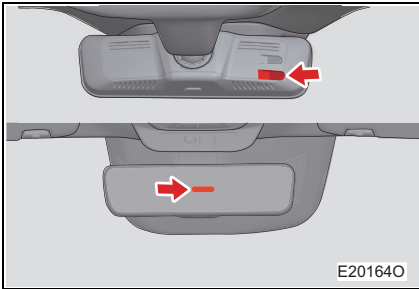

Interior rearview mirror has automatic anti-glare function, which uses the front and rear sensors to detect the light intensity of vehicles behind and reduce the reflected light automatically.

### WARNING

#### ■ During driving

- Do not adjust the position of the rearview mirror while driving, as this may result in an accident due to mishandling, which could lead to serious injury or even death.
- Stacking items in the rear seats beyond the seat back height will obstruct the sight in the rearview mirror, which could result in a traffic accident. Therefore, do not stack items beyond the seat back height.

## 4-2. Steering wheel and rearview mirror

### Exterior rearview mirror

#### Adjusting exterior rearview mirror

When the vehicle power supply is set to ON mode, the angle of exterior rearview mirror can be adjusted.

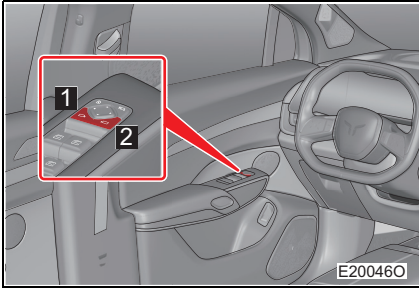

Press the corresponding exterior rearview mirror selector button. Then the button indicator lamp comes on.

- 1** Left
- 2** Right

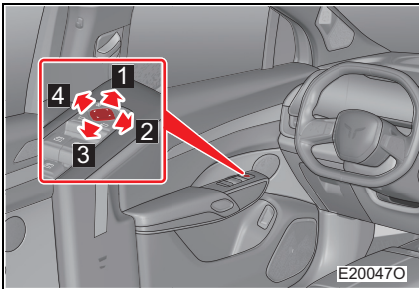

Press the button to adjust the exterior rearview mirror on the corresponding side.

- 1** Move upward
- 2** Move rightward
- 3** Move downward
- 4** Move leftward



## Folding exterior rearview mirror

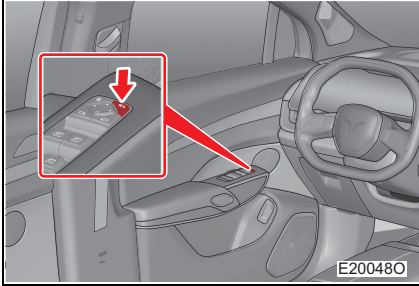

Press the exterior rearview mirror folding button to fold the exterior rearview mirror; press the button again to unfold the mirror.

The exterior rearview mirror will automatically fold when the vehicle is locked, and automatically unfold when the vehicle is unlocked.

The automatic folding function of exterior rearview mirrors can be turned on and off through the vehicle settings interface of the in-vehicle infotainment system. (See P.190)

## Exterior rearview mirror heating



Method 1: Touch  button on the A/C operation interface. Then the indicator lamp comes on, exterior rearview mirror and rear windshield can be heated simultaneously.

Touch  button again. Then the indicator lamp goes out, and deactivate the heating.

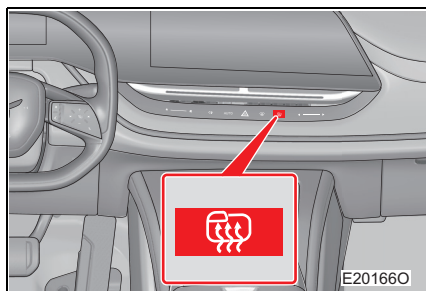

Method 2: Touch  button on the A/C operation panel. Then the indicator lamp comes on, exterior rearview mirror and rear windshield can be heated simultaneously.

Touch  button again. Then the indicator lamp goes out, and deactivate the heating.

Note: The system will be turned off automatically after a period of operation and the indicator lamp will go out.

---

### ■ Operating conditions of exterior rearview mirror angle adjustment function

The vehicle power supply is set to ON mode and the parking brake is applied.

### ■ Operating conditions of exterior rearview mirror folding switch and heating switch

Vehicle power supply is set to ON mode.

### ■ Using power mode in cold weather

In cold weather where the exterior rearview mirrors may freeze, the automatic folding and unfolding feature may not function in power mode. In this case, remove the snow and ice from the exterior rearview mirrors, and then operate the mirrors manually.

### ■ Exterior rearview mirror memory

The exterior rearview mirrors feature a memory function that can be linked with the seat and steering wheel memory. (See P.133)

### ■ Automatic adjustment of right rearview mirror

When the shift lever is set to R position and exterior rearview mirror selection is in right side, if this function is turned on, the right rearview mirror automatically tilts down to provide the driver with a back-up view. After the shift lever has been out of R position for 10 seconds or the vehicle is in D gear and when the vehicle speed exceeds 15 km/h, the rearview mirror automatically returns to its previous position.

With the shift lever in R position, the driver can adjust the right rearview mirror to an appropriate angle, which is memorized as the target downward tilt position.

 **WARNING****■ When driving**

Please observe the following precautions while driving. Failure to do so may result in loss control of the vehicle and cause an accident, resulting in serious injury or even death.

- Always look around before changing lanes.

It is dangerous to change lanes without considering the actual distance of the vehicle in the exterior rearview mirror. Since the actual distance of the object is closer than what you see in the exterior rearview mirrors, it can lead to a serious accident.

- Do not drive with the exterior rearview mirror folded. Be sure to reset the exterior rearview mirrors to the unfolding position before driving.

**■ When adjusting the exterior mirror**

To avoid personal injury and rearview mirror fault, be careful not to have your hands pinched by the mirror in motion.

**■ When operating the exterior rearview mirror heater**

- Do not touch the surface of the exterior rearview mirror, as it will become hot and may cause burns.
- Turn off the exterior rearview mirror heating function when there is no need for heating.

**■ Precautions when driving**

Please observe the following precautions while driving:

- Do not adjust the rearview mirror while driving.
- Both left and right rearview mirrors must be unfolded and properly adjusted before driving.

# Power window

### Opening and closing power windows

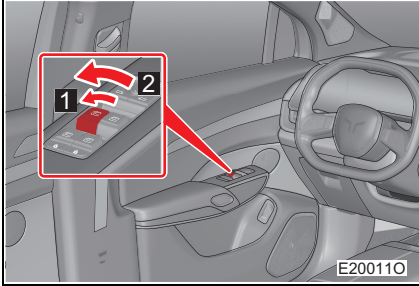

- 1 Manual lifting/lowering**  
Pull up/press down the corresponding window regulator switch to position 1 (keep pulling up/pressing down), to achieve manual lifting/lowering of the windows.
- 2 Automatic lifting/lowering**  
Pull up/press down the corresponding window regulator switch to position 2 (pull up/press down and release), to achieve automatic lifting/lowering of the windows.

The driver's power window switch can control other windows.

---

#### ■ Operating conditions of power windows

Vehicle power supply is set to ON mode.

#### ■ Operate the power windows after the vehicle power supply is turned off

The power windows can be operated even after the vehicle power supply is turned off for a period of time.

#### ■ Locking rear power window

Rear power window and door can be locked by rear door child safety lock to prevent children from opening the rear doors and operating the window in the vehicle. (See P.107)

#### ■ Initialization operation

After the automatic window lifting/lowering function is disabled, the windows need to be initialized as follows:

- With the window glass in any position (more than 4 mm from the top of the window frame) within the effective anti-pinch area, continue pulling up the switch for the window to be initialized to close the window fully, and keep this action for about 2 seconds or more, then fully open and close the power window once to complete the initialization operation.

If necessary, contact an authorized FAW Hongqi dealer.

### ■ Anti-pinch function

In case of an obstacle during the automatic closing, the power window can automatically return to a safe position.

### ■ Automatic window closing function

With vehicle power supply in OFF mode and the window not closed, the window will be automatically closed after the rain/light sensor determines the amount of rain.

The automatic window closing function can be turned on and off through the vehicle settings interface of the in-vehicle infotainment system. (See P.190)

### ■ Remote window lifting

With all doors, the front compartment cover and the back door closed, press and hold the lock button on the smart key within the effective range to close all windows.

### ■ Intelligent window lifting

With all doors, the front compartment cover and the back door closed, carry the smart key with you and press and hold the door handle sensor switch to close all windows.



## WARNING

### ■ To avoid serious personal injury or even death, observe the following precautions when closing the windows:

- During operation on the windows, do check carefully to ensure that no part of the driver and passenger's bodies will be pinched.
- Do not allow children to operate the power windows.

### ■ Anti-pinch function

- Do not activate the anti-pinch function by intentionally stopping the moving window with any part of your body.
- The anti-pinch function may not work if an object is pinched when the window is about to close fully (4 mm).
- If the automatic window lifting/lowering function or the anti-pinch function is disabled, initialization is required.

## 4-4. A/C system

# Automatic A/C system

This vehicle is equipped with a dual-zone A/C system that automatically adjusts the outlet air temperature, air volume, air outlet mode and air supply mode to provide the desired driving environment for the occupants according to the temperature setting, combined with the current interior temperature, ambient temperature, sunlight intensity, vehicle speed, water temperature and other environmental parameters.

► A/C operation interface of in-vehicle infotainment system



- 1 Driver side temperature setting button
- 2 Driver side AUTO button
- 3 Driver side air volume setting button
- 4 Front passenger side air volume setting button
- 5 Front passenger side AUTO button
- 6 Front passenger side temperature setting button
- 7 A/C setting button
- 8 Front passenger side wind direction mode setting button
- 9 Front passenger side air outlet mode button
- 10 PM2.5 button
- 11 Windshield/exterior rearview mirror defrosting/defogging button
- 12 Front windshield forced defrosting/defogging button
- 13 ON/OFF button
- 14 Natural ventilation button
- 15 Recirculation/fresh air/automatic circulation mode button
- 16 Synchronization button
- 17 Driver side air outlet mode button
- 18 Driver side wind direction mode setting button

Touch  button on in-vehicle infotainment system to enter A/C interface; In A/C interface, you can switch to seat or fragrance setting interface to set the corresponding function.

► A/C operation panel

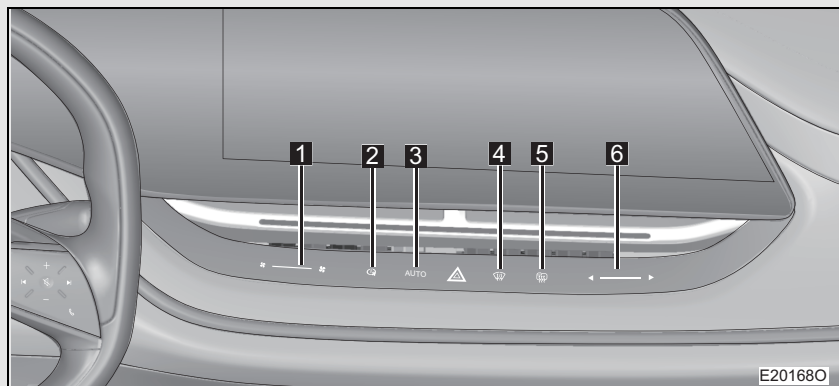

- 1** Driver air volume setting button
- 2** ON/OFF button
- 3** Driver AUTO button
- 4** Front windshield forced defrosting/defogging button
- 5** Windshield/exterior rearview mirror defrosting/defogging button
- 6** Driver temperature setting button



## Using automatic A/C system



Method 1: Touch the [AUTO] button on the A/C operation interface to enter the automatic A/C mode, where the temperature adjustment mode can be selected.

In automatic mode, the air volume setting button is automatically changed to the temperature adjustment mode button.

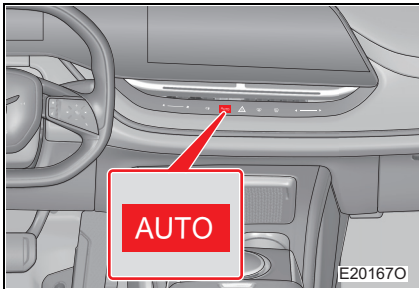

Method 2: Touch [AUTO] button on the A/C operation panel, the indicator lamp will come on, and driver side enters the auto A/C mode.

In synchronization mode, both driver side and front passenger side enter the auto A/C mode simultaneously.

The auto A/C mode corresponding to temperature zone on the driver side and front passenger side can be set separately.

In automatic A/C mode, you can set the temperature by touching the temperature setting button according to your personal needs, and the system will control the air outlet mode and air volume according to the selected temperature, temperature adjustment mode setting and the influence of external environment.

■ [AUTO] button indicator lamp

- If the air outlet mode is operated, [AUTO] button indicator lamp does not go off, but at this time, air outlet mode cannot be controlled automatically (automatic defogging function is not triggered).

■ Using automatic mode

The air volume is automatically adjusted according to the temperature setting and environmental conditions. Therefore, the following situations may occur.

- In summer, when the low temperature setting is selected, the system will automatically switch to the recirculation mode.
- After the switch is pressed, the blower may not turn immediately or may run at low speed until the warm or cold air is ready for normal air supply operation.



Manual adjustment setting

■ Adjusting air volume

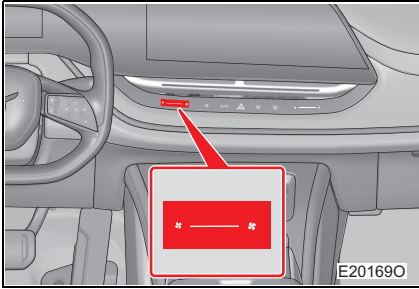

Method 1: Touch the air volume setting bar on the A/C operation interface to adjust the air volume of the current side A/C system among level 0-7. Level 0 indicates that one side is turned off.





Method 2: Touch or slide  button or  button on the A/C operation panel to adjust the air volume of driver side A/C system among level 0-7. Level 0 indicates that one side is turned off.

In synchronization mode, both driver side and front passenger side adjust the air volume simultaneously.

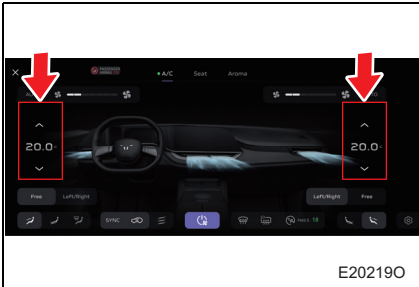

The air volume cannot be adjusted manually in the automatic mode (temperature adjustment mode can be adjusted) until the automatic mode is turned off manually.

#### ■ Adjusting temperature



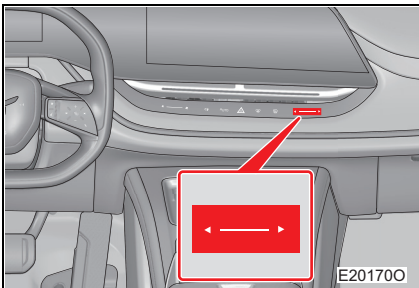

Touch the temperature setting button  (increase) or  (decrease) on the A/C operation interface or slide the temperature display value up and down to set the temperature.



Method 2: Touch or slide  button or  button on the A/C operation panel to set the driver side temperature.

In synchronization mode, both driver side and front passenger side adjust the temperature simultaneously.

### ■ Turning off A/C

Touch  button on the A/C operation interface or  button on the A/C operation panel to turn off the vehicle A/C system.

### ■ Switching temperature zone control mode



Touch the [SYNC] button on the display. Then the indicator lamp will come on, the single temperature zone control mode will be activated, and the temperature, air volume and mode on front passenger side will be synchronized to the settings on the driver side.

Touch the [SYNC] button again. Then the indicator lamp goes out, the dual temperature zone control mode will be activated, and the temperature, air volume and mode on driver side and front passenger side can be set separately.

If the temperature, air volume and mode on front passenger side are set separately in the single temperature zone control mode, the dual temperature zone control mode will be activated.

### ■ Switching air outlet mode

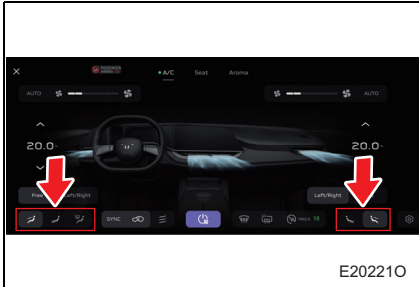

Touch the air outlet mode selection button to select the corresponding air outlet mode, and touch it again to cancel the air outlet mode. The air outlet modes can be combined for selection.

### ■ Adjusting blowing direction



After face mode is turned on, drag the wind direction icon on the A/C operation interface to adjust the blowing direction of air outlet for face.

After face mode is turned on, touch the wind direction selection button on the display to set the blowing direction of air outlet to free, mirror image, one-way or automatic swing.

### ■ Switching recirculation/fresh air mode

Touch the [Recirculation/fresh air/automatic circulation mode button] on the A/C operation interface to switch the modes. When



button comes on, the recirculation mode is activated; when



button comes on, the recirculation/fresh air mode is activated;

when  button comes on, the fresh air mode is activated.

When the outside pollution detection function is turned on and in the automatic circulation mode, if the outside air pollution is severe, the fresh air mode will be turned off automatically and the recirculation mode will be activated to control the interior air quality automatically. (See P.159)

In automatic A/C mode, the A/C system automatically switches between recirculation and fresh air mode, but the display still shows automatic recirculation/fresh air modes.

If it is in manual fresh air mode, when the wiper water spray is turned on, it briefly switches to the recirculation mode to reduce the irritating odor of detergent that enters the vehicle.



### **WARNING**

#### ■ **Do not use the recirculation mode in cold or rainy weather**

Using the recirculation mode in cold or rainy weather can cause the windows to fog up, which can obstruct your vision and could lead to a serious accident.

#### ■ **When using recirculation mode**

The windows may fog up easily if the recirculation mode has been in use for a long time.

## Other functions

### ■ Front windshield forced defrosting/defogging

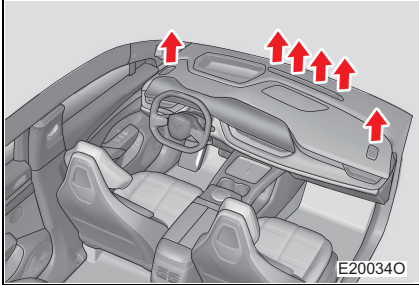

Touch  button on the A/C operation interface or the A/C operation panel. Then the indicator lamp comes on, and the front windshield forced defrosting/defogging function is turned on.

In the recirculation mode, if the front windshield forced defrosting/defogging function is on, the system will automatically switch to the fresh air mode.

Increase the air volume and temperature to defrost/defog the front windshield as soon as possible.

### ■ Window fogging

- In rainy weather, the windows may fog up.
- The windows may fog up if the recirculation mode has been in use for a long time.

### **WARNING**

#### ■ Preventing windshield fogging

- When the weather is extremely humid, do not use the front windshield forced defrosting/defogging mode during cooling operation. The temperature difference between the air outside the vehicle and the windshield may cause the outer surface of the windshield to fog up, obstructing your vision.
- Do not place any objects on the instrument panel that may cover the air outlets as this may block the airflow and hinder the front windshield defogging.

### ■ Auto defogging mode (ADS)

When A/C is in AUTO mode and the front windshield fogs up and has a tendency to affect driving safety, the A/C system enters auto defogging mode, and the air outlet mode changes to front windshield mode. When the tendency is released, the A/C system will automatically switch back to the operating state before defogging. When the auto defogging mode is activated, operate the air outlet mode adjustment button to exit the auto defogging mode.

Prompt: When the auto defogging mode is activated, the air volume of the A/C system will be large.

Auto defogging function can be turned on/off on the A/C setting interface. (See P.159)

### ■ Automatic interior air purification



The system operates in two modes, with monitoring mode on by default. Touch the [PM2.5] button on the operation interface once to enter the immediate purification mode and activate anion generator simultaneously, and press the button again to enter the monitoring mode.

**Automatic mode:** The system automatically monitors the air quality inside the vehicle, and when PM2.5 value in vehicle is high, the system automatically enters the immediate purification mode for filtration. After the filtration is completed, the system automatically returns to the monitoring mode. Auto purification function can be turned on/off on the A/C setting interface. (See P.159)

**Immediate purification mode:** The filtration function is manually forced on. When the filtration is completed, the monitoring mode must be activated manually to turn off the filtration function.

**Monitoring mode:** After A/C is turned on, the system only monitors the interior air quality, it displays PM2.5 value after blower is turned on, but it does not perform any purification actions.



#### ■ Automatic protection against outside pollution

The system automatically detects the outside air quality and is in the automatic circulation mode. When the outside air is polluted, the A/C system automatically switches to recirculation mode to prevent polluted air from entering the vehicle, thus guaranteeing proper interior air quality. Automatic protection against outside pollution can be turned on/off on the A/C setting interface. (See P.159)

#### ■ Natural ventilation function

Touch the natural ventilation button on the display to activate the natural ventilation mode, the air inlet mode is switched to fresh air mode and air outlet mode is switched to face + foot mode. At this time, the compressor stops operating, thus saving energy.

#### ■ A/C setting

Touch the A/C setting button to enter setting interface to turn on/off the A/C function.

- Automatic protection against outside pollution: External air exchange will be cut off automatically when it detects the polluted air outside the vehicle.
- Automatic interior air purification: When PM2.5 value in vehicle is high in the automatic circulation mode, air purification will be automatically turned on.
- Auto defogging: When the driver AUTO is turned on, enter the auto defogging state, and window defogging mode will activate automatically when it detects a risk of fogging on the front windshield.
- Single seat mode: When no passengers are detected in other seats except the driver seat, the A/C outlets for other seats except the driver seat will be turned off.

### ■ Fragrance system\*

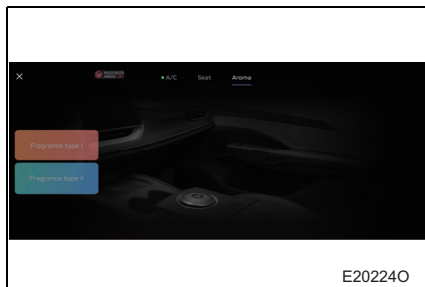

After selecting the appropriate fragrance mode and level, the system will cooperate with the A/C to improve the interior environment of the vehicle for enhanced comfort of the driver and passengers.

### ■ Remote operation of A/C system

- The A/C system can be remotely operated through the mobile APP. (See P.75)

### ■ Recirculation/fresh air mode

- When driving on dusty roads (e.g. tunnels) or congested roads, switch to the recirculation mode. This effectively prevents outside air from entering the vehicle. During cooling operation, turning on the recirculation mode will also effectively reduce the interior temperature.
- The windows may fog up if the recirculation mode has been in use for a long time.
- If it is in manual fresh air mode, when the wiper water spray is turned on, it briefly switches to the recirculation mode to reduce the irritating odor of detergent that enters the vehicle.

### ■ Windshield defroster

- In the front windshield forced defrosting/defogging mode, the system will switch to fresh air mode from recirculation mode automatically.
- The air volume may increase when the defrosting/defogging function is in operation, which helps defrost/defog the front windshield as soon as possible.

### ■ A/C odor

- During use, various odors from inside and outside the vehicle may enter and accumulate in the A/C system. This may cause odors to emanate from the air outlets.

**CAUTION****■ Preventing a low 12 V battery**

Turn off the A/C system if it is not needed when the vehicle is not started.

## 4-4. A/C system

# Rear windshield heating



Method 1: Touch  button on the display. Then the indicator lamp comes on, and the system starts heating rear windshield and exterior rearview mirror.

Touch  button again. Then the indicator lamp goes out, and the system stops.

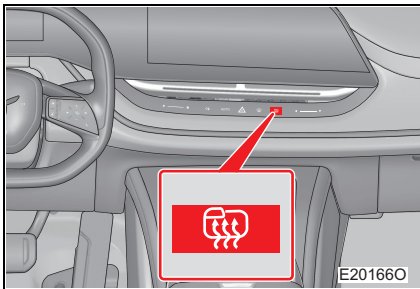

Method 2: Touch  button of the instrument panel switch assembly. Then the indicator lamp comes on, and the system starts heating the rear windshield and exterior rearview mirror.

Touch  button again. Then the indicator lamp goes out, and the system stops.

Note: The system will be turned off automatically after a period of operation and the indicator lamp will go out.

### **WARNING**

#### ■ **Precautions during rear windshield heating**

Do not touch the heating area as it may become very hot and cause burns.

## 4-5. Interior power supply

# On-board wireless charging

The center armrest is equipped with a wireless charging system.

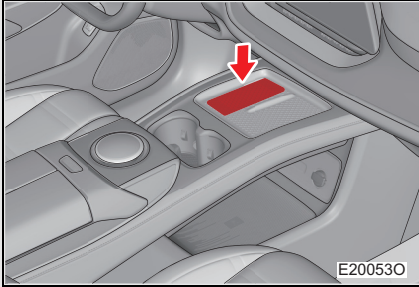

Mobile phones that support Qi standard wireless charging can be placed in the wireless charging area for charging.

Mobile phones that do not support Qi standard wireless charging need to be charged with a receiver.

### ■ Operating conditions of on-board wireless charging system

Vehicle power supply is set to ON mode.

#### **WARNING**

#### ■ Before charging, please remove all metal objects from the charging pad

If there are any metal objects (such as coins, keys, rings or paper clips) between the mobile phone and the charging pad while the phone is charging wirelessly, do not remove them immediately by hand to avoid burning your fingers. Please remove the mobile phone first and wait for the metal objects to cool down before removing them.



## CAUTION

### ■ When charging

- Remove all items from the wireless charging area. If there are foreign objects, the system may not charge properly.
- The mobile phone should be placed face up in the middle of the anti-slip mat.
- Try to avoid long periods of direct sunlight on a charging mobile phone, and try to avoid placing the phone in extreme positions such as corners, otherwise it may increase the risk of mobile phone overtemperature.

### ■ Please do not place magnetic cards such as expressway toll cards or bank cards in the wireless charging area, as they may cause demagnetization or damage

### ■ Wireless charging disabled

It is normal that if you start the vehicle or leave the vehicle with the key during wireless charging, the wireless charging will be interrupted for a short time.

- Do not remove the rubber pad. Ensure that the rubber pad is properly installed before charging.
- Do not place containers containing liquid on the surface of wireless charger to prevent liquid from flowing into the charger.

## 4-5. Interior power supply

# Power outlet

### ■ 12 V power

The power outlet can be used for 12 V accessories with operating current less than 10 A.

#### ▶ Front

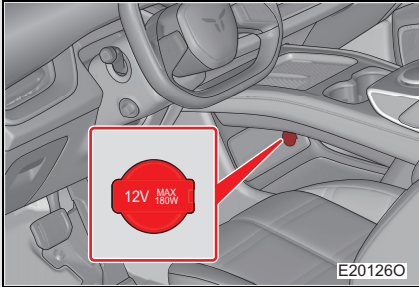

Located under the front auxiliary fascia console.

#### ▶ Rear

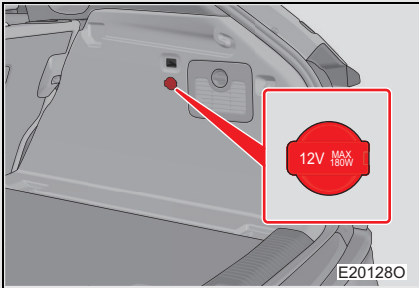

Located on the right trim panel of trunk.

### ■ USB power

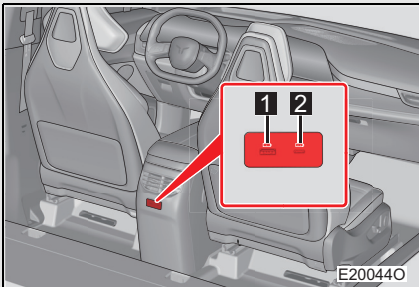

Located at the lower end of rear center air outlet.

**1** Type-A port (18W)

**2** Type-C port (60W)

---

### ■ Operating conditions of power outlets

Vehicle power supply is set to ON mode.



### CAUTION

#### ■ Preventing damage to power outlets

When the power outlet is not in use, the power outlet cover should be closed, otherwise foreign objects or liquids will enter the power outlet and cause short circuit.

#### ■ Preventing blown fuses

Do not use accessories that exceed the rated voltage/current.



## 4-6. Interior lamp

# Using interior lamp

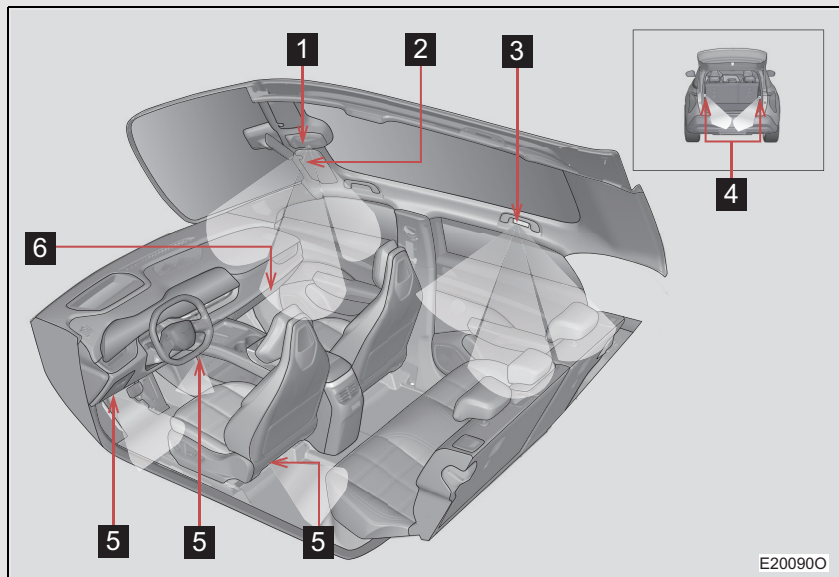

- 1** Front reading lamp
- 2** Vanity mirror lamp
- 3** Rear reading lamp
- 4** Trunk lamp
- 5** Ambient lamp\* (See P.192)
- 6** Glove box lamp

## Front reading lamp

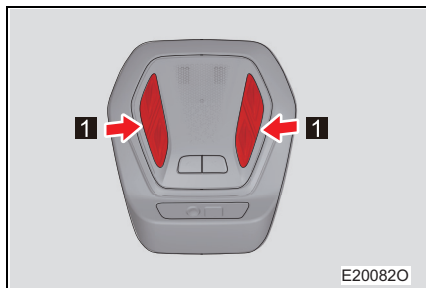

- 1 Touch the front reading lamp position to turn on the front reading lamp, and touch it again to turn off the front reading lamp.

The reading lamp can be turned on automatically through the lighting settings interface of the in-vehicle infotainment system (see P.192).

## Rear reading lamp

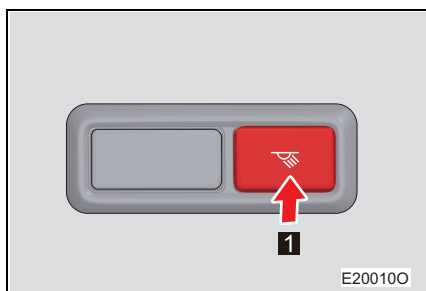

- 1 Touch  button to turn on the rear reading lamp on the corresponding side, and touch the button again to turn off the rear reading lamp.

## Vanity mirror lamp

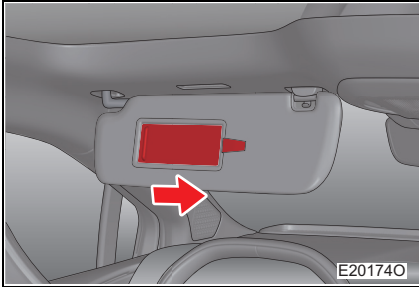

- 1 Open the sun visor and open the vanity mirror cover to turn on the vanity mirror lamp.
- 2 Close the vanity mirror cover to turn off the vanity mirror lamp.

### Energy saving control

With the front interior lamp switch in the door linkage position, if the door is opened, the interior lamp will be on for a period of time and then go out; when the vehicle power supply is turned off and the doors are closed, the interior lamp and ambient lamp will go out after a delay.

### CAUTION

#### Preventing a depleted battery

Turn off the interior lamps when not needed.

Do not allow the vanity mirror cover or the doors to be in open status for a long time. When they are opened, the corresponding interior lamps will come on and the battery may be depleted.

## 4-7. Storage compartments

# Storage compartments list

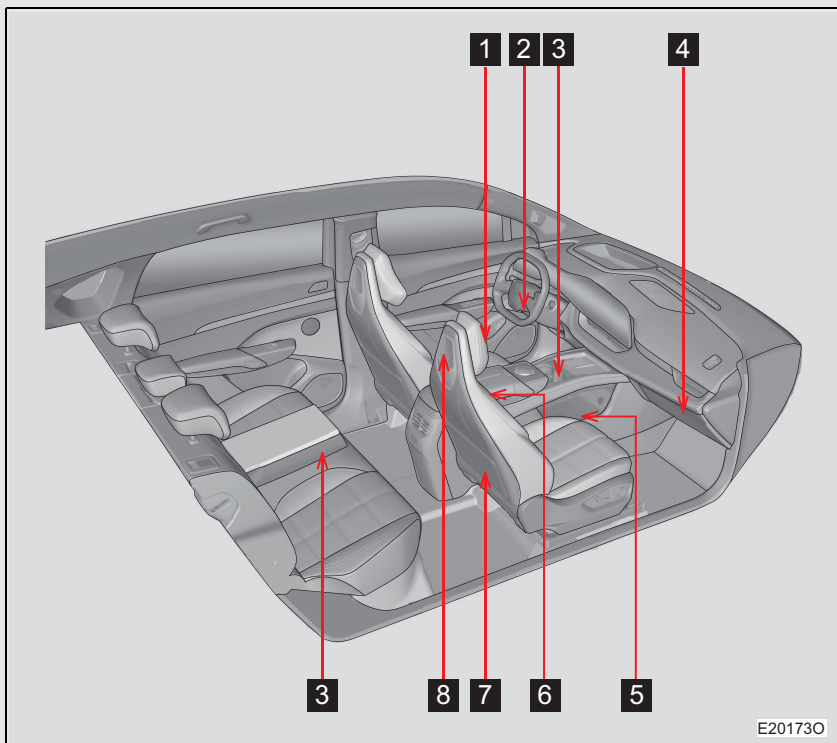

- 1** Door storage box
- 2** Storage box on left lower guard
- 3** Cup holder (front/rear)
- 4** Glove box
- 5** Front storage box
- 6** Front center storage box
- 7** Document pocket
- 8** Headrest storage tank

## Glove box

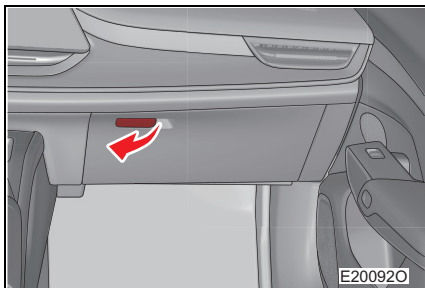

Pull the release handle to open the glove box.

When closing the glove box cover, a "click" is emitted to indicate that it is securely locked.

### **WARNING**

#### ■ **Warning during driving**

Keep the glove box closed.

Failure to do so may result in personal injury in the event of an accident or emergency braking.

## Front center storage box

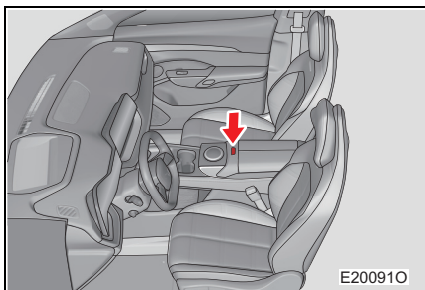

Press the storage box switch to pop up the front center storage box cover.

### **WARNING**

#### ■ **Warning during driving**

Keep the storage box closed.

Failure to do so may result in personal injury in the event of an accident or emergency braking.

## Storage box on left lower guard

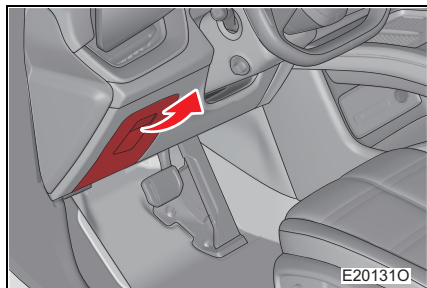

Pull the opening handle to open the storage box.

When closing the storage box cover, a "click" sound indicates that it is firmly locked.

### **WARNING**

#### ■ **Warning during driving**

Keep the storage box closed.

Otherwise it may affect normal driving of the driver, and result in injury in the event of an accident or emergency braking.

## Cup holder

### ► Front

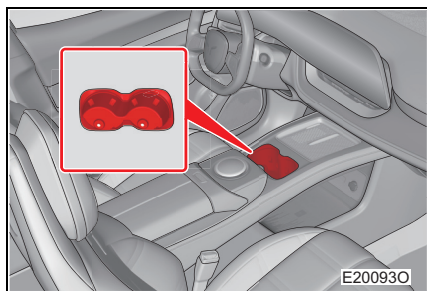

It can be used to securely place cups, movable ashtrays or beverage cans, etc.

► Rear

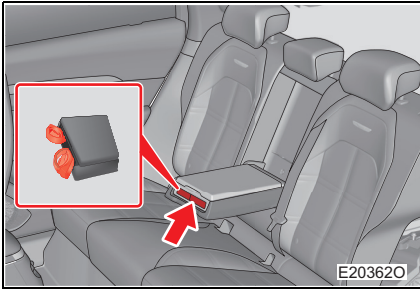

Press and release the cup holder cover to enable the rear cup holder to automatically pop out.

Retract the cup holder when it is not in use.

■ **When storing a cup in cup holder**

- Tighten the cup cover.
- Depending on size or shape, certain cups may not be stored in the cup holder.

**⚠ WARNING**

■ **When using cup holder**

- Do not place anything other than cups or aluminum cans in the cup holder, as such items may be thrown out of the cup holder and cause personal injury in the event of an accident or emergency braking.
- It is dangerous to use a cup holder for holding a cup with hot liquid. If the liquid inside the cup is spilled, it may cause burns.
- Be careful to prevent foreign objects such as liquids from coming into contact with the electrical parts around the cup holder, as this may cause risk of short circuit or electric shock.

■ **When not in use**

Keep the cup holder closed. Failure to do so may result in personal injury in the event of an accident or emergency braking.

### Storage box

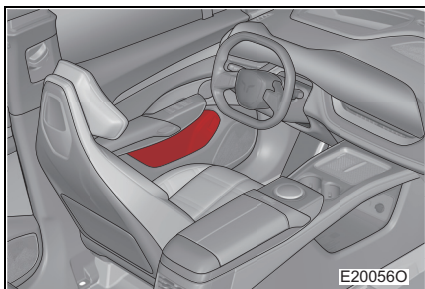

A storage box is provided on each door and can be used to store miscellaneous items such as bottles or rags.

When storing bottles, tighten the caps.

Depending on size or shape, certain bottles may not be stored in the storage box.

### Document pocket

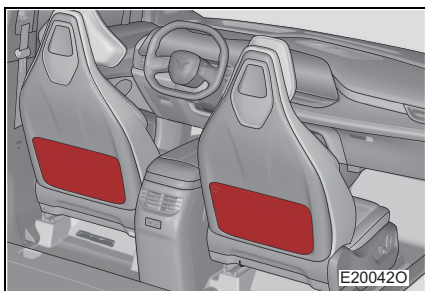

Document pockets are located on the rear of the driver's and front passenger's seat backs.

They are used for storing newspapers, magazines and other items.



### Headrest storage tank\*

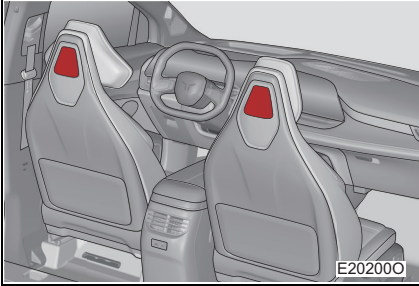

Headrest storage tank is located on the rear of the driver's and front passenger's seat headrest.

It is used to store mobile phones, business cards and other items.

### Rear center storage box

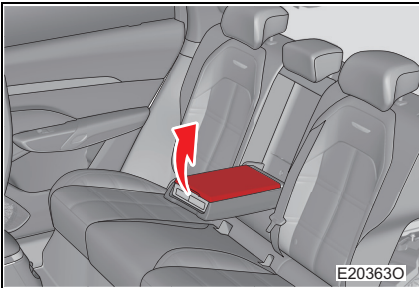

Lift the storage box cover to open the storage box.

## Front compartment storage box

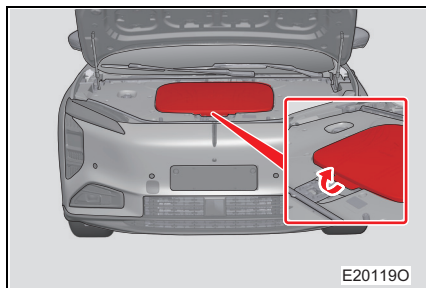

Open the front compartment cover to see the front storage box, which is used to store items.

### CAUTION

- **Preventing front compartment storage box from being damaged**
  - Load in front compartment storage box should not exceed 15 kg, otherwise, it may be damaged.
  - It is forbidden to place inflammable, explosive and dangerous articles to avoid fire and injury.
- **It is forbidden to place fragile articles to avoid damage.**
- **It is forbidden to place valuables to avoid financial loss.**

## 4-8. Other equipment

# Using other equipment

### Sun visor

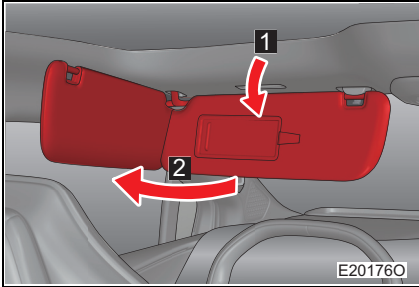

#### 1 Front position

Turn down the sun visor.

#### 2 Side position

Turn down the sun visor, unhook it, and pull it to the side.

### Document holder

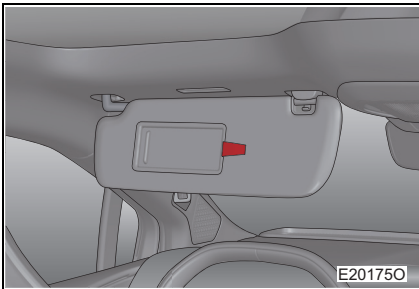

The document holder is located on the driver's sun visor.

It is used to store tickets, business cards and other objects.

#### CAUTION

#### ■ Preventing damage to the document holder

Do not put too many objects in the document holder.

## Vanity mirror

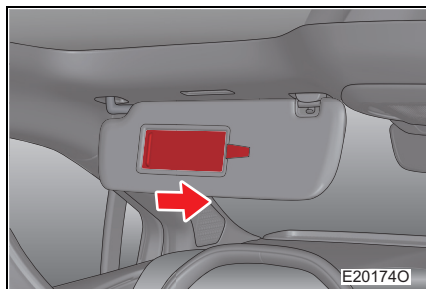

Turn down the sun visor and slide the vanity mirror cover to open the mirror. At this time, the vanity mirror lamp comes on.

### CAUTION

#### ■ When not in use

Keep the vanity mirror closed.

#### ■ Preventing low battery

Do not allow the vanity mirror lamp to be on for a long time while the vehicle is not started.

## Rear center armrest

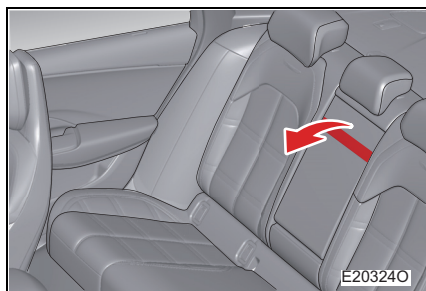

Pull down the armrest to use it.

### CAUTION

#### ■ Preventing damage to the armrest

● Do not press down hard or place heavy objects on the armrest when using it, and do not ride on the armrest.

## Roof grab handle

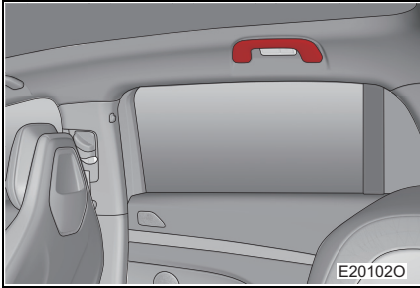

The roof grab handles are located at the roof side beams.

When sitting in the seat, you can have your body supported by the roof grab handles.

### **WARNING**

#### ■ **Roof grab handle**

Do not use the roof grab handles when getting on and off the vehicle or when getting up from the seat.

### **CAUTION**

#### ■ **Preventing damage to the roof grab handles**

Do not hang any heavy objects or apply heavy loads to the roof grab handles to prevent damage.

## Coat hook

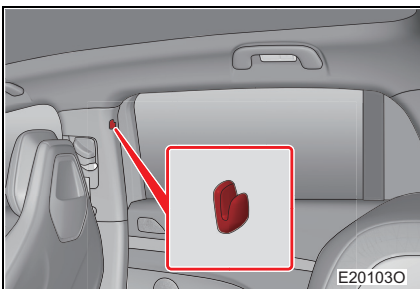

You can hang your clothes on the coat hook.



**WARNING**

■ **Items that should not be hung on coat hook**

Do not hang clothes racks or other hard or sharp objects on the coat hook. If the curtain airbag is deployed, these objects may be ejected, resulting in serious injury or death.

**5-1. Basic operation**

- Multimedia display ... 182
- USB data interface ... 186

**5-2. Using in-vehicle  
infotainment system**

- Setting\* ..... 188
- Navigation\* ..... 199
- Entertainment\* ..... 203
- Extended  
application\* ..... 204

**5-3. Using hands-free  
system**

- Hands-free system ... 206

**5-4. Using voice recognition**

- Voice recognition ..... 209

# 5-1. Basic operation

## Multimedia display

Users can operate the functions such as navigation, Bluetooth phone, Qiting and setting through the multimedia display.

### Entertainment display

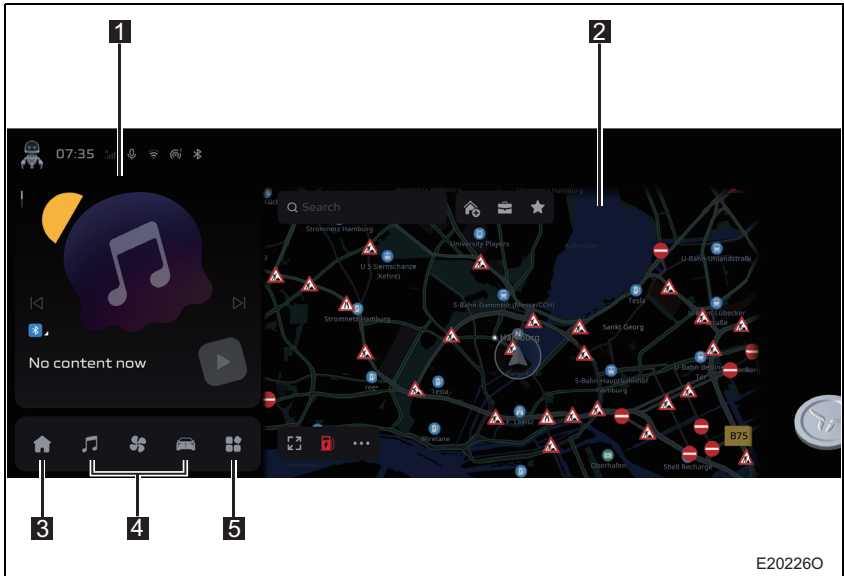

E202260

No.	Name	Function
1	Main menu interface	Slide up and down on the main menu interface to switch between [Entertainment] - [Vehicle information] card, displaying tire pressure, battery and other information.
2	Function display interface	Corresponding interface is displayed when turning on each function
3	Home page	Enter home page
4	DOCK bar	Long press the quick access icon to replace it with quick access buttons for radio, Bluetooth music, local music, setting, 360 around view, or A/C.



5	Extended application	Enter [Extended application] function interface, and weather, Bluetooth phone, file management and other functions can be viewed and operated.
---	----------------------	--

### ■ Shortcut menu on entertainment display

With system on, swipe down on the main menu interface to pull out the shortcut menu, and you can quickly access to some functions such as message center, etc.

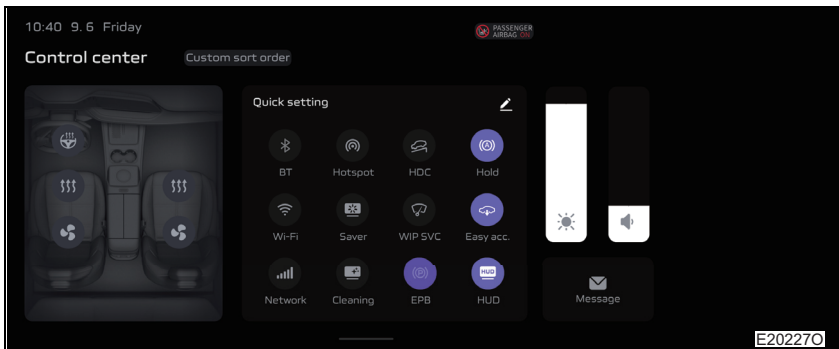

### ■ Preventing damage to the multimedia display

- During operation, touch the multimedia display gently with fingers. If the content shown on the multimedia display cannot be called out, it indicates that the content may not be available at the moment. Do not press the screen buttons excessively to avoid damage to the device.
- Do not use sharp or angular hard objects to touch the multimedia display; otherwise the multimedia display may be damaged.
- Do not spray liquid directly onto the multimedia display. If liquid leaks into the equipment, the electronic components may be damaged.
- When cleaning the surface of the multimedia display, set vehicle power mode to OFF mode and wipe the screen with a soft and dry cloth. Do not use coarse rags, chemical rags or organic reagents (alcohol, benzene, disinfectant, etc.) for cleaning, as they can damage or deteriorate the panel.

### ■ When using the multimedia display

- If the multimedia display is cold, the display may be dark, or the system may seem to be operating slightly slower than normal.
- The display may be dark or difficult to see clearly when you wear sunglasses, so change the angle of the multimedia display or remove the sunglasses.

- Do not expose the multimedia display to sunlight for a long time.
- Do not expose the multimedia display to moisture, dust, oil smoke, etc.



### **WARNING**

#### **■ When using the in-vehicle infotainment system**

- Please avoid operating the system as much as possible while driving.
- The volume should be adjusted properly so that the situation outside the vehicle can be heard during driving. If the volume is adjusted too high to hear the situation outside the vehicle, an accident may be caused.
- Do not use the system in a fault state where there is no image or sound, as this may cause a traffic accident, fire, electric shock or fatal injury.
- Do not operate the system in no-parking areas, as this may result in traffic accidents.
- For the sake of safety, the use of this function shall never distract your attention or hinder safe driving. Ignoring road and traffic conditions can lead to accidents.

#### **■ Do not disassemble or modify this product without permission, as this may cause traffic accident, fire, or electric shock.**

#### **■ In case of abnormal conditions such as entry of foreign materials or water ingress, stop using the system immediately and contact an authorized FAW Hongqi dealer. If you continue to use the system, a fault may occur.**

 **CAUTION****■ Noise from the in-vehicle infotainment system**

- Due to the high sensitivity of this system, the system may make interference noises when closing to TV towers, radio stations, power plants or other places with strong radio waves or electrical noise interference.
- During operation, the system may make interference noises when a mobile phone is used in or near the vehicle.

**■ Preventing damage to the in-vehicle infotainment system**

Be careful not to spill drinks or other liquids on the in-vehicle infotainment system. If liquid or other objects enter the unit, switch off the power immediately and contact an authorized FAW Hongqi dealer.

**■ Compatibility**

Some devices may not work properly due to their own compatibility.

**■ In case of a fault**

If the fault cannot be eliminated, please contact an authorized FAW Hongqi dealer.

## 5-1. Basic operation

# USB data interface

After connected to the USB data interface, an USB device can be operated through the in-vehicle infotainment system.

### Using USB data interface

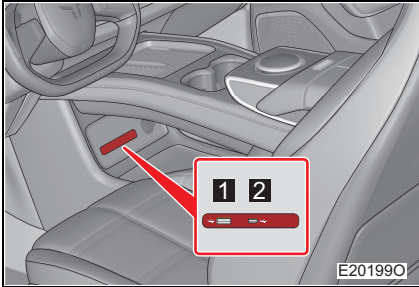

1 USB1

2 USB2

#### ■ USB memory

Connect a USB memory device.

If the USB memory is not started, turn on its power supply.

#### WARNING

#### ■ During driving

Do not connect the device or operate its control buttons to prevent accidents.

**CAUTION****■ Preventing damage to USB devices or their terminals**

- Be sure to keep the interface clean. If foreign matter or liquid enters the interface, the in-vehicle infotainment system may malfunction.
- Do not plug high-current USB devices other than U disk and mobile phone, such as mobile hard disks and portable powers.
- Do not leave the USB device in the vehicle, as the temperature inside the vehicle may rise, causing damage to the USB devices.
- Do not press or apply unnecessary pressure to the USB device when it is connected.
- Do not insert foreign objects into the interface.

**■ Compatibility**

Some devices may not work properly due to their own compatibility.

**■ Ensuring proper system recognition**

USB devices with poor quality may not be identified by the system, so it is recommended to use high-quality USB devices.

**■ When getting off the vehicle**

Do not leave items such as mobile phones in the vehicle. The temperature inside the vehicle may rise, causing damage to mobile phones.

**■ Mobile phone data cable**

The USB cables supplied with mobile phones are recommended for connection to ensure a stable connection.

## 5-2. Using in-vehicle infotainment system Setting\*

On the main menu interface, touch  button to enter setting function interface.

### Driving setting

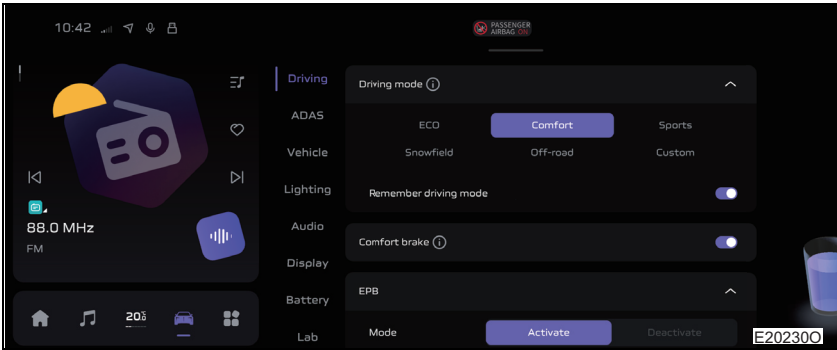

#### 1 Driving mode

- Set 6 driving modes, namely economic, comfort, sport, snow, off-road and custom; At the same time, set the driving characteristics in custom mode.
- Driving mode memory: Set the ON/OFF of driving mode memory.
- Energy saving mode: Set the ON/OFF of driving mode memory in economic mode.

#### 2 Comfort brake

Set the ON/OFF of comfort brake function.

#### 3 Electronic parking brake

Apply or release the electronic parking brake manually.

#### 4 AUTO HOLD

Set the ON/OFF of AUTO HOLD function.

#### 5 AUTO HOLD after power-off

Set the ON/OFF of AUTO HOLD function after power-off.

#### 6 ESC

Set the ON/OFF of ESC.

**7 Hill descent control**

Set the ON/OFF of hill descent control.

**8 Trailer mode**

Set the ON/OFF of trailer mode.

## Driver assistance settings

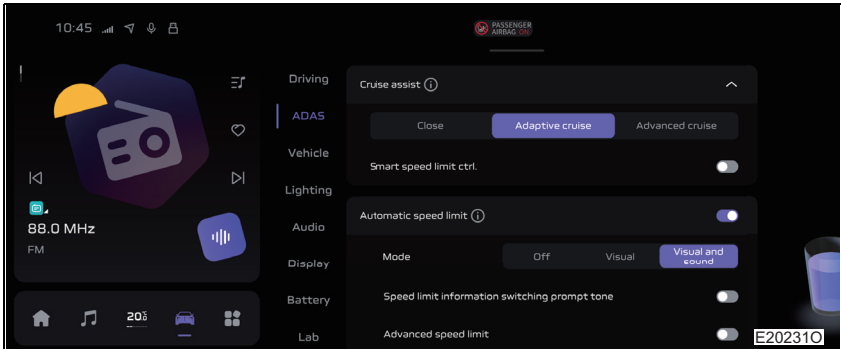
**1 Cruise assist**

Set the ON/OFF of cruise function. Cruise mode can be set to SACC or ACC.

- DCLC: DCLC function can be turned on/off in SACC mode.
- Intelligent speed limit control: Intelligent speed limit control function can be turned on/off in ACC mode.

**2 Intelligent speed limit**

Set the ON/OFF of intelligent speed limit.

- Speed limit information switching prompt tone: Set the ON/OFF of speed limit information switching prompt tone.
- Advanced speed limit: Set the ON/OFF of advanced speed limit.
- Road feature speed limit: Set the ON/OFF of road feature speed limit.
- Local hazard speed limit: Set the ON/OFF of local hazard speed limit.

**3 Driver attention reminder**

Set the ON/OFF of driver attention reminder function.

**4 Pre-collision assistance**

- **Forward collision warning:** Set the ON/OFF of forward collision warning.  
Mode: Set the alarm mode to Front Collision Warning (FCW) only or alarm + Automatic Emergency Braking (AEB).  
Sensitivity: Alarm trigger sensitivity can be set to low, medium or high.
- **Rear collision warning:** Set the ON/OFF of the rear collision warning.
- **Rear collision brake:** Set the ON/OFF of the rear collision brake.
- **Emergency steering assist:** Set the ON/OFF of emergency steering assist.
- **Door opening safety warning:** Set the ON/OFF of door opening warning function.

### 5 Lane assistance

- **LKA:** Set the ON/OFF of LKA.  
Mode: Set the lane department alarm mode to Lane Departure Warning (LDW), or alarm + Lane Keeping Assist (LKA).  
Sensitivity: Alarm trigger sensitivity can be set to low or high.
- **Emergency lane keeping:** Set the ON/OFF of emergency lane keeping function.
- **Blind spot safety warning:** Set the ON/OFF of blind spot detection and lane change assist function.

## Vehicle setting

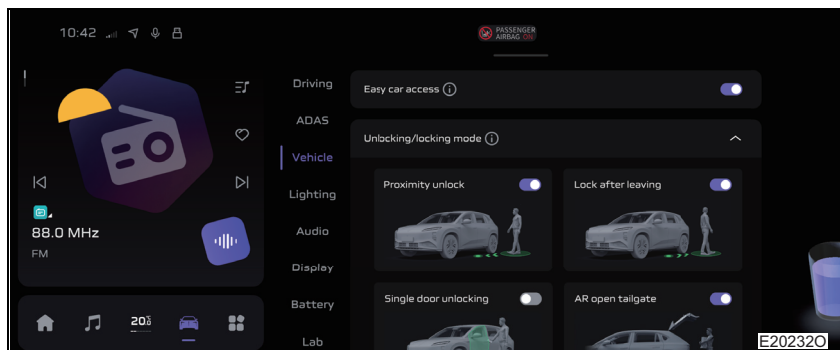

### 1 Easy car access

Set the ON/OFF of welcome function.



## 2 Unlocking/locking mode

Set unlocking/locking method to proximity unlocking, locking after leaving, single door unlocking and trunk sensing unlocking.

- Proximity unlocking: When this function is turned on, if the driver approaches the vehicle with the smart key carried, the vehicle will be unlocked automatically.
- Locking after leaving: When this function is turned on, if the driver leaves away from the vehicle with the smart key carried, the vehicle will be locked automatically.
- Single door unlocking: When this function is turned on, press the smart key unlock button once to unlock the driver's door; press the smart key unlock button twice consecutively to unlock all doors.
- Trunk sensing unlocking: When the function is turned on, set the trunk sensing unlocking.

## 3 Windows

- Auto closing of windows after locking the vehicle: Set the ON/OFF of automatic window closing function after locking the vehicle.
- Auto closing of windows in rainy days: Set the ON/OFF of the automatic window closing function in rainy days.

## 4 Exterior rearview mirror auto folding when locking

Set the ON/OFF of auto folding of exterior rearview mirror when locking the vehicle.

## 5 Custom button of steering wheel

"\*" button on multi-functional steering wheel can be set as audio source switching, driving mode switching, theme switching and automatic parking.

## 6 Mobilization reminder

Set the ON/OFF of mobilization reminder.

When the function is turned on, if the vehicle is moved in locked status, the owner will be notified through the Hongqi Zhilian APP.

## 7 Service detection

- Wiper service mode: Set the ON/OFF of wiper service mode.

When the wiper service mode function is turned on, place the wiper in the service position if conditions permit.

- Lifting mode: Set the ON/OFF of lifting mode.

## Lighting setting

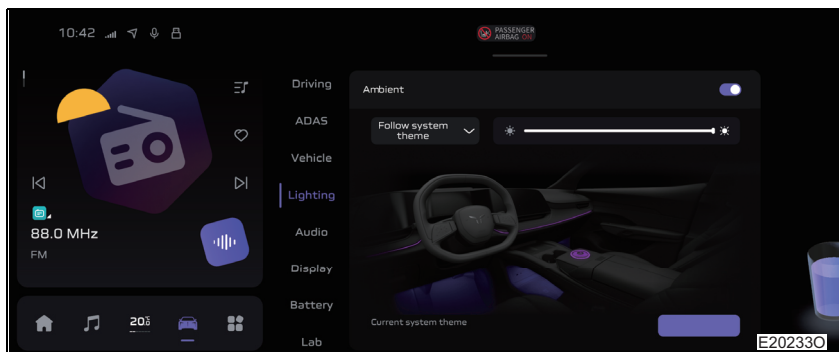

### 1 Ambient lamp

Set the ON/OFF of ambient lamp.

- It can be used to adjust brightness and color, and set the ambient lamp color switch along with driving mode.

### 2 Lamp

- Intelligent high beam lamp: Set the ON/OFF of intelligent high beam lamp control system.
- Boarding/getting-off lighting delay: Set the ON/OFF and duration of getting-off lighting and boarding lighting.
- Automatic ON for reading lamp : Set the ON/OFF of Automatic ON for reading lamp.
- Low beam lamp height: Adjust the low beam lamp height manually.

## Sound setting

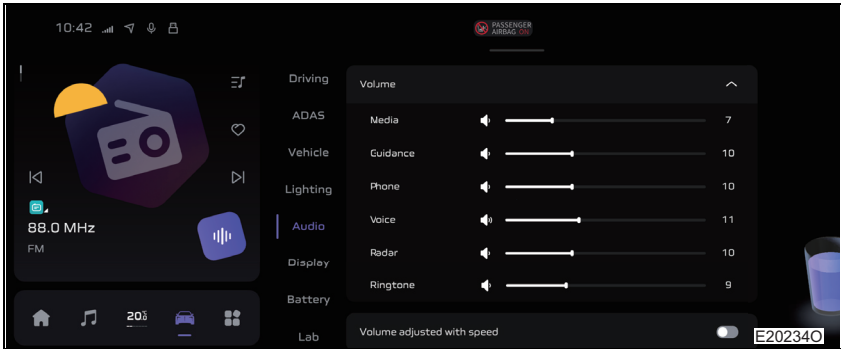

### 1 Volume

The volume of multimedia, navigation, phone, voice, radar, ringtone and other functions can be adjusted.

### 2 Volume adjustment with vehicle speed

Set the ON/OFF of volume adjustment with vehicle speed.

- Adjustment level can be set to low, medium or high.

### 3 Key tone

Set the ON/OFF of screen key tone.

### 4 Timbre

The treble, mid and bass levels can be adjusted.

### 5 Sound field

Five modes can be set: Entire vehicle, driver, virtual surround, rear row or custom.

### 6 Pedestrian warning sound

Set the ON/OFF of exterior pedestrian warning sound.

### 7 Interior engine simulation sound

After it is turned on, set the mode and volume of interior engine simulation sound.

### 8 Alarm tone of instrument cluster

Alarm tone can be set to low, medium or high.

### ■ Voice setting

Touch [Voice setting] on the sound setting interface to enter the voice recognition setting interface. (See P.210)

## Display setting

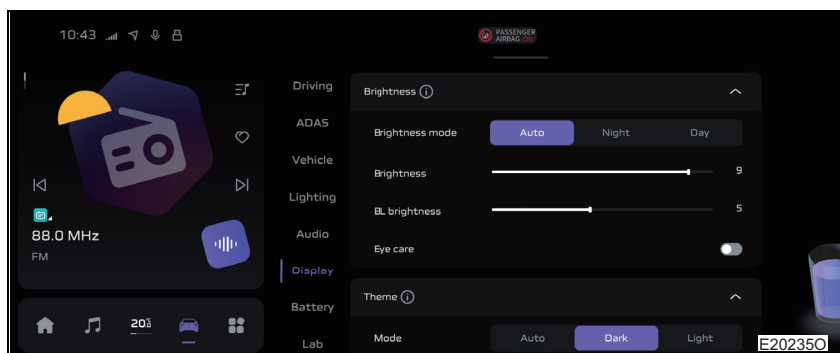

### 1 Central control screen

- Brightness mode of central control screen: Three display modes can be set: Auto, night and day.  
In auto mode, the daytime display brightness can be set when the position lamp is turned off, and the nighttime display brightness can be set when the position lamp is turned on. After setting, it will be automatically adjusted to the set brightness when the position lamp is turned on/off.
- Brightness of central control screen: The brightness of central control screen can be adjusted.
- Instrument cluster and vehicle backlight brightness: Instrument cluster and vehicle backlight brightness can be adjusted.
- Eye protection mode: Set the ON/OFF of central control screen eye protection mode.

### 2 Theme

- Mode: Three display modes can be set: Auto, dark color and light color.
- Theme color: Select and switch theme color.

### 3 Font size

Font size can be set to standard or large.

**4** Instrument cluster display

- Instrument cluster simple mode: Set the ON/OFF of instrument cluster simple mode.
- Recent average power consumption cycle: The recent average power consumption cycle can be set to 25 km or 50 km.

**5** Screensaver

The screensaver can be set as a mechanical clock, digital clock or image.

**6** HUD

Set the ON/OFF of head-up display.

- Parameter adjustment: Click parameter adjustment button, use steering wheel to adjust head-up display parameters.  
(See P.217)

## Energy setting

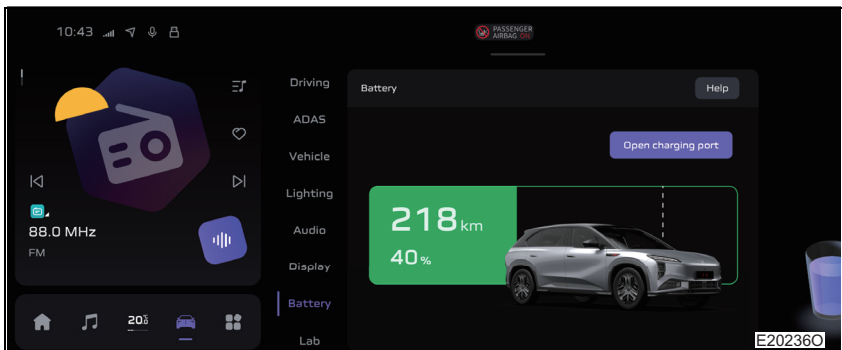
**1** Battery

View the current battery level and driving range.

**2** Driving range display

Set the driving range display mode to standard or dynamic.

**3** Charging appointment

Timed charging function can be turned on/off, and the start and end time for timed charging can be set.

**4** Charging limit

The charging limit range can be set between 50% - 100%, and the setting interval is 5%.

### 5 Discharging limit

The discharging limit range can be set between 5% - 40%, and the setting interval is 5%.

### 6 Heating/cooling during driving

Set the ON/OFF of heating/cooling during driving.

### 7 Auto power off

Set the ON/OFF of auto power off.

## Lab

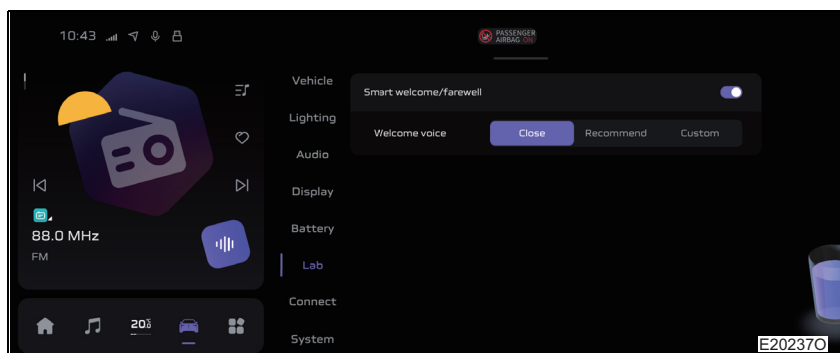

### 1 Smart welcome/farewell

Set the ON/OFF of lamp welcome/farewell when the vehicle is unlocked or locked.

- Welcome voice can be set to off, smart recommend or custom.

## Connection setting

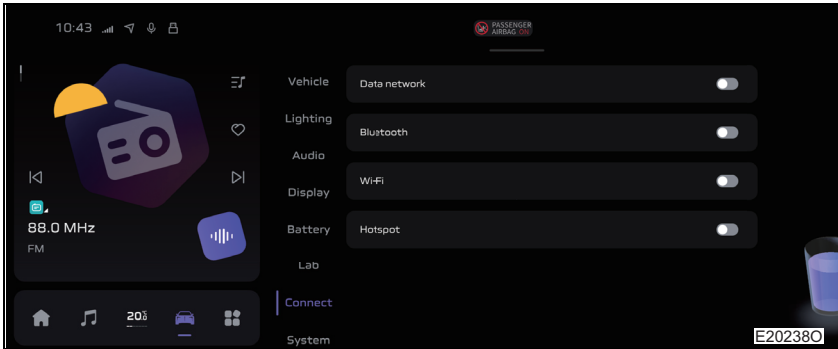

### 1 Data network

- The mobile data network can be turned on/off or switched.

### 2 Bluetooth

- Bluetooth can be turned on or off. When Bluetooth is turned on, the saved devices and available devices can be viewed, connected and deleted, and the Bluetooth name can be set at the same time.

### 3 WiFi

- WiFi can be turned on or off. When WiFi is turned on, connected networks and available networks can be viewed and connected.

### 4 Hotspot

- Hotspot can be turned on or off. When hotspot is turned on, the currently connected devices can be viewed, and the hotspot name, password and frequency band can be set at the same time.

### System setting

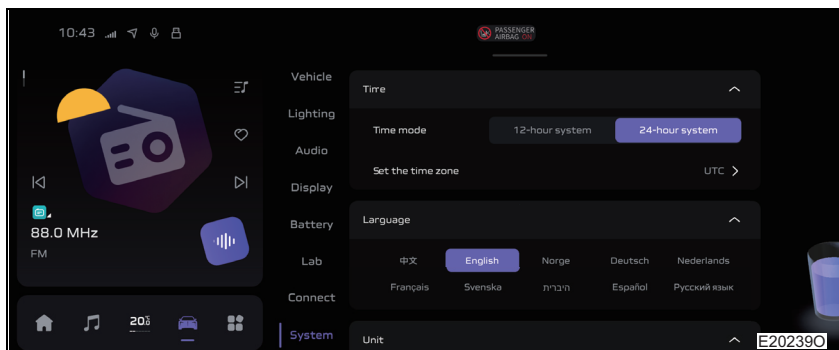

#### 1 Time

- Mode: The time mode can be set to 12h format or 24h format.

#### 2 Language

System language can be switched.

#### 3 Unit

- Distance: It can be switched to km or mile.
- Temperature: It can be switched to °C or °F.
- Pressure: It can be switched to bar, kPa or psi.

#### 4 Privacy

- Location service: Set the ON/OFF of location services.
- Voice service: Set the ON/OFF of voice services.
- Personal data collection: Set the ON/OFF of personal data collection.
- Privacy agreement: Privacy agreement can be viewed.
- Service agreement: Service agreement can be viewed.

#### 5 About the system

System information can be viewed.

#### 6 Factory reset

System can be restored to factory setting.

#### 7 System upgrade

Vehicle-related systems can be upgraded. Please contact the authorized FAW Hongqi dealer for specific operation.



## 5-2. Using in-vehicle infotainment system Navigation\*

The navigation function interface is the default interface of multimedia display. You can enter the navigation function interface after turning on the multimedia display or quitting each function interface.

### Navigation map interface

#### ■ Map mode interface

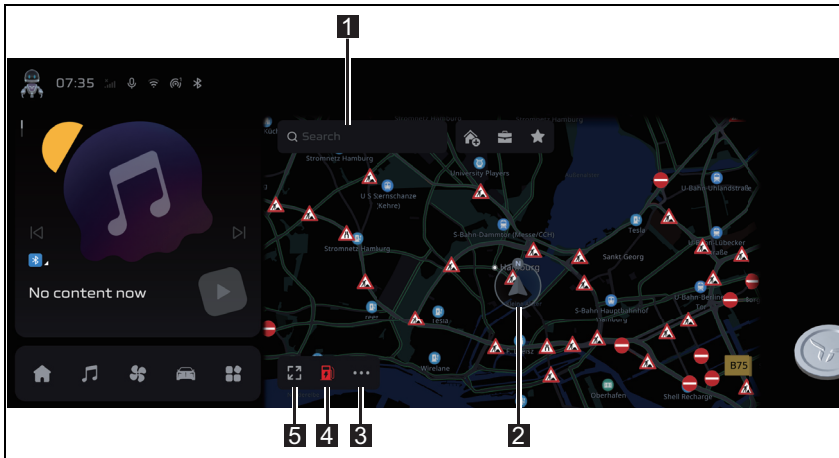

#### 1 Search for destination

Touch to search for the destination.

#### 2 Current position

Display the current position of the vehicle.

#### 3 More

Touch to expand and set more functions.

#### 4 Charging station

Touch to display nearby charging stations for quick navigation.

#### 5 Full-screen display

Navigation interface is displayed in full screen.

## ■ Navigation mode interface



### 1 Turning arrow

Display the direction of travel at the next intersection.

### 2 Distance to the next intersection and road name

Display the remaining distance to the next intersection and the road name.

### 3 Overview of road conditions

Display the current navigation process.

### 4 Current position

Display the current position of the vehicle.

### 5 Remaining mileage and time

Display the remaining mileage, time to the destination and estimated arrival time.

## Navigation setting

Touch  on the navigation interface to enter the setting interface.

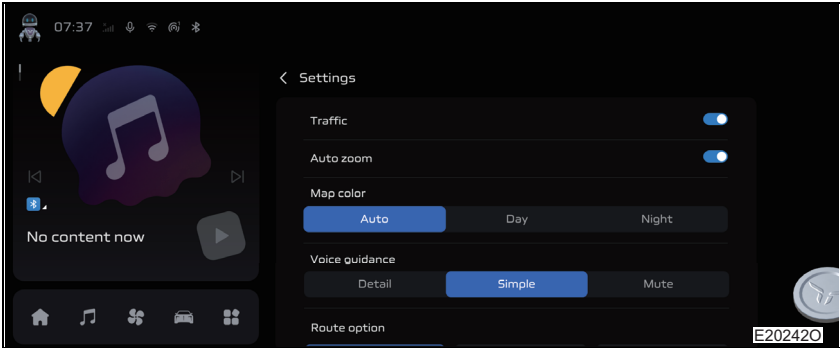

### 1 Navigation

Map color, auto zoom, route selection, navigation voice and other functions in the navigation process can be set.

### 2 Offline map

Download or update offline map packages all over the country.

### 3 Others

Clean up the personal data and restore the default settings.

## WARNING

### ■ During driving

- When navigating a route through the navigation system, please drive according to the actual traffic rules. Navigating according to path of navigation system may violate traffic rules sometimes, resulting in a traffic accident.
- During driving, driver should not perform operations such as address search, etc. Please operate after stopping the vehicle. Failure to observe the conditions ahead may lead to a traffic accident.



## CAUTION

- **At present, all on-board navigation systems have certain limitations. Satellite conditions, road structure, vehicle conditions and other factors may affect the accuracy of vehicle positioning, which will affect the normal function of system. If you have any questions, please contact the authorized FAW Hongqi dealer.**
- **Network connection quality**

The network connection quality will vary due to the constant change of antenna position, the difference in signal strength, and the influence of nearby objects (such as trains and transmitting stations), which make it difficult to maintain perfect reception quality.
- **Due to the continuous updating of navigation version, the actual operation interface may be different from the illustration. Please refer to the latest version.**
- **For owners of Hongqi E202 vehicle, it is easy to verify map version information on the central control screen. These data updates will be provided free of charge to the owner. If the data is based on the map, it is updated at least once a year for seven years from the vehicle's manufacture date (excluding costs related to public storage media, personal computer and operating system, private or mobile Internet fees, travel costs for authorized dealers, repairers, distributors or independent repairers). Subsequent updates may be subject to a reasonable fee. Map information can be updated online. As specified in Article 3.4.2.5.5.2 of Regulation (EU) 2021/1958.**

## 5-2. Using in-vehicle infotainment system Entertainment\*

On the main menu interface, touch  button to enter the entertainment function interface.

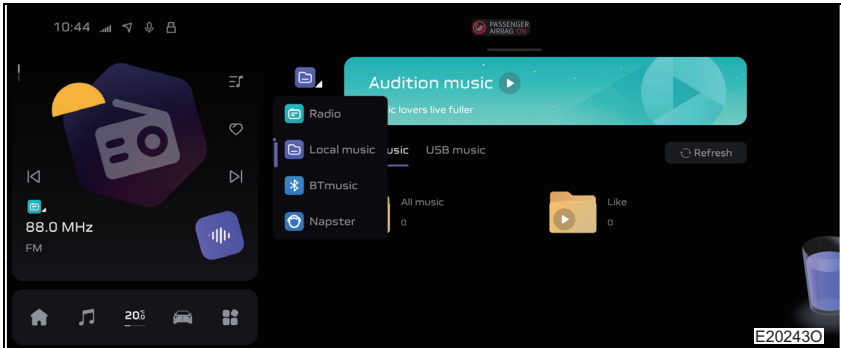

### 1 Radio

Play and search for FM radio, AM radio and DAB radio.

### 2 Local music

View and play the local music.

### 3 Bluetooth music

View and play Bluetooth music.

### 4 Napster

View and play Napster music.

### ■ Antenna

The radio antenna is printed on the rear windshield.

## 5-2. Using in-vehicle infotainment system

# Extended application\*

On the main menu interface, touch  button to enter the extended application function interface.

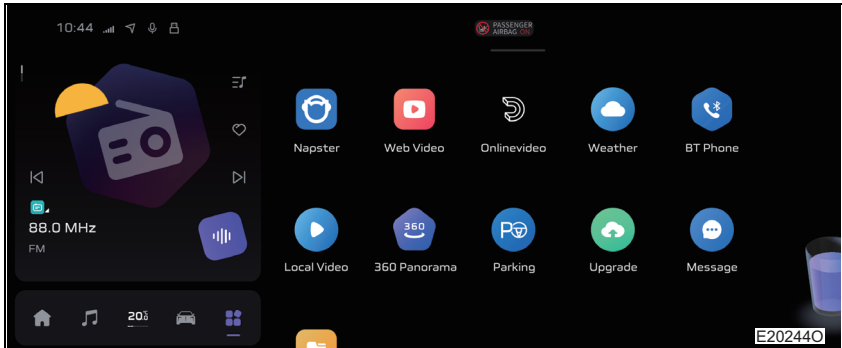

### 1 Napster

View and play Napster music.

### 2 Web video

View and play the web video.

### 3 Online video

View and play the online video.

### 4 Weather

View the current weather.

### 5 Bluetooth phone

On-board Bluetooth phone function can be used after connecting to Bluetooth.

### 6 Local video

View and play the local video.

### 7 360 panorama

View vehicle, application and activity related prompt messages.

### 8 Parking

Auto parking assist (APA) can be turned on.

### 9 Upgrade service

Upgrade the system.

**10** Message center

View vehicle, application and activity related prompt messages.

**11** File management

View and manage local, USB1 and USB2 files.

## 5-3. Using hands-free system

# Hands-free system

**The hands-free system has the function of operating the phone without touching the mobile phone.**

This system support Bluetooth® mobile phones. Bluetooth® is a wireless data system that establishes wireless connection between the mobile phone and the hands-free system.

### ■ Phone button

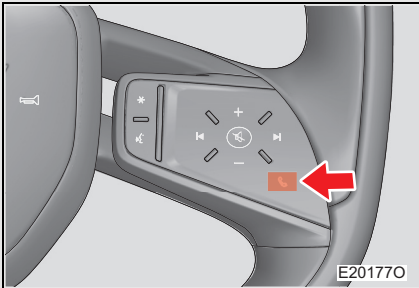

The phone button is located in the position shown in the figure.

**See the following table for specific functions:**

Information description	Function
Press	In case of an incoming call: Answer the current incoming call; Call/dial-out state: Hang up the current call; In case of no incoming call: Display the last call information, and pressing again will dial out.
Press and hold	In case of an incoming call: Hang up the current call; In case of no incoming call: Automatically dial out the last call number.

Before using the hands-free system, you must bind a Bluetooth phone.



### ■ Bluetooth microphone

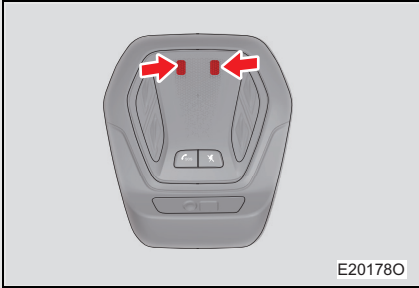

Located near the front interior lamp.

- If the volume of reception is too high, you may hear an echo.
- Try to face the microphone when speaking.
- Under the following circumstances, it may be difficult for the other party to hear the sound:
  - Phone signal is poor.
  - Drive on an unpaved road.
  - Drive at high speed.
  - Window is open.
  - The A/C outlet is facing the microphone.
  - The air volume of A/C blower is too high.

### ■ The system will be inoperative under the following conditions:

- The used phone does not support Bluetooth®.
- The mobile phone is turned off or in flight mode.
- The current location is outside the service area.
- The mobile phone is not connected.
- The mobile phone battery is low.

### ■ Bluetooth® antenna

If a mobile phone is placed in the storage box, or in contact with or covered by metal materials, its connection state may deteriorate.

### ■ Battery level/signal status

This display may not be exactly consistent with that of mobile phones.

■ **About Bluetooth®**



Bluetooth® is the trademark of Bluetooth SIG, Inc.

■ **Compatible type**

The Bluetooth hands-free system is only compatible with Bluetooth certified (SIG) phones sold through regular channels and of mainstream brands.

 **CAUTION**

■ **When getting off the vehicle**

Do not leave items such as mobile phones in the vehicle. The temperature inside the vehicle may rise, causing damage to mobile phones.

# Voice recognition

**Users can realize the voice control of the system through the voice recognition.**

**The control functions mainly include: Entertainment, Bluetooth phone, A/C control and window control etc.**

### Voice recognition trigger

Method 1: Press  button on the steering wheel to trigger the voice recognition system.

Method 2: Click the voice icon in the upper left corner of the main menu interface of multimedia display to trigger the voice recognition system.

Method 3: Say the wake-up password to trigger the voice recognition system.

The voice recognition wake-up word can be set in the voice setting of in-vehicle infotainment system. (See P.209)

Method 4: Say the voice command directly to trigger the voice recognition system and execute the voice command.

The ON/OFF of wake-up free can be set in the voice setting of in-vehicle infotainment system. (See P.209)

### Voice recognition exit

Method 1: After triggering the voice recognition system, if there are no recognition commands, the system will automatically exit the voice recognition.

Method 2: The system will exit the voice recognition after the normal execution of voice commands.

Method 3: The system will exit the voice recognition after touching  button on the steering wheel.

Method 4: Say the exit command to exit the voice recognition.

## Voice setting

Touch  in the upper right corner of the voice wake-up interface or voice setting in the sound setting interface to enter the voice recognition setting interface.

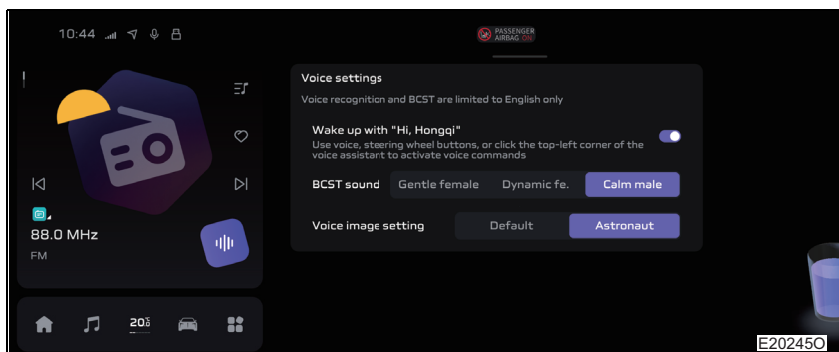

### 1 Wake up with "Hi, Hongqi!"

Set the ON/OFF of voice recognition using the wake-up words.

### 2 Broadcast sound

Different sound types can be set.

### 3 Voice image skin setting

Voice image skins can be switched.

## CAUTION

- **The voice recognition results are for reference only.**
- **Please use standard and clear Mandarin, and do not activate the voice recognition when the environment is noisy, so as to avoid incorrect recognition results.**
- **Try to avoid using the voice recognition while driving. If voice recognition is used in such case, please pay attention to the road conditions to prevent danger.**
- **The functions included in voice setting may update with the system version.**

**6-1. Instrument information**

Instrument cluster ....212

Head up display\* .....216

**6-2. Driving specifications**

Driving the vehicle ....219

Vehicle power supply  
mode .....226

Gearshift control .....228

Driving mode .....232

Air suspension\* .....236

**6-3. Operating lamps and wipers**

Headlamp switch .....240

Intelligent high beam  
control (IHC)\* .....244Turn signal lamp control  
lever .....247

Fog lamp switch .....248

Front windshield wiper &  
washer .....249Rear windshield wiper &  
washer .....253**6-4. Using driver assistance system**Adaptive cruise control  
(ACC)\* .....255Super adaptive cruise  
control (SACC)\* .....264Tire pressure monitoring  
system (TPMS) .....271Lane keeping assist  
(LDW/LKA)\* .....273Driver status monitor  
(DSM)\* .....276Forward collision warning  
(FCW)\* .....279Autonomous emergency  
braking (AEB)\* .....282Blind spot detection  
(BSD)\* .....286Emergency steering  
assistance (ESA)\* ..293Intelligent speed limit  
warning system

(ISA)\* .....296

Driver controlled lane  
change (DCLC)\* .....298

Reverse tracking\* .....305

Driver assistance  
system .....309

## 6-1. Instrument information

# Instrument cluster

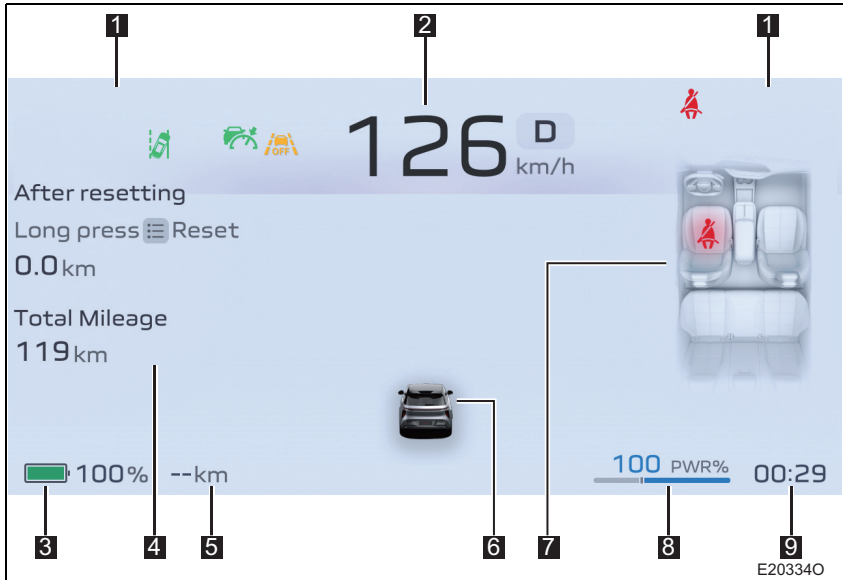

Depending on vehicle configurations, the specific displayed information will vary.

**1** Prompt/alarm icon display area

Display information regarding vehicle indicator lamps and warning lamps.

**2** Speedometer

Display the vehicle speed.

**3** Battery level display area

Display the current vehicle battery level percentage.

**4** Driving information display area

Display the mileage, radar, cruise following distance and other information.

**5** Vehicle driving range display area

Display the current vehicle driving range, and can switch standard energy consumption or dynamic energy consumption.

**6** Comprehensive information display area

**7** Energy distribution/seat belt information display area

Display the current usage of the interior seat belt or energy distribution information.

- 8 Power information display area  
Display the current vehicle power percentage.
- 9 Time display area  
Display the clock information.

## Instrument cluster and vehicle backlight brightness

The instrument cluster and vehicle backlight brightness can be adjusted in the display settings of in-vehicle infotainment system. (See P.194)

### WARNING

#### ■ In case of brightness adjustment

For the sake of safety, please adjust the backlight brightness during parking, and do not distract attention and hinder safe driving while using this function. Ignoring road and traffic conditions can lead to accidents.

## Buttons on steering wheel

### ■ Buttons on the left of steering wheel

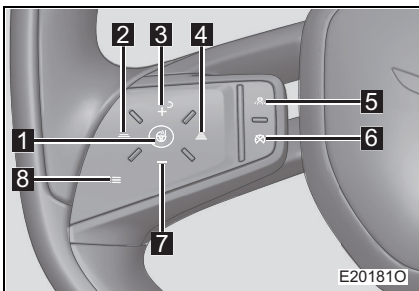

- 1 AI button (reserved)
- 2 Decreasing following distance button
- 3 Increasing cruise speed button
- 4 Increasing following distance button
- 5 Cruise ON button
- 6 Cruise canceling button
- 7 Decreasing cruise speed button
- 8 Menu button

No.	Function
1	Press: — —
2	Press: Decrease following distance with cruise ON
3	Press: With cruise ON, increase the cruise speed; With cruise canceled, resume cruise; While cruising, actively accelerate to exceed the set cruise speed, the current vehicle speed can be set as the cruise speed
4	Press: Increase following distance with cruise ON
5	Press: Turn on ACC or SACC
6	Press: With ACC/SACC function ON, cruise control is canceled
7	Press: Reduce cruise speed with cruise ON
8	Press: Switch between short-term driving mileage, total mileage, and power consumption Press and hold: Reset trip mileage

### ■ Buttons on the right of steering wheel

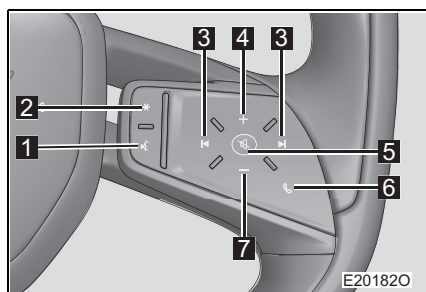

- 1** Voice recognition button
- 2** Multi-function button
- 3** Track/radio station button
- 4** Volume increasing button
- 5** Mute button
- 6** Phone button
- 7** Volume decreasing button



No.	Function
1	Press: Trigger/exit the voice recognition function
2	Press: Switch multimedia audio sources, theme and driving mode, capture with driving recorder Press and hold: Enter in-vehicle infotainment system to perform function settings of the multi-function button (See P.192)
3	Press: Previous track/next track
4	Press: Increase the volume, and unmute if muted
5	Press: Mute/unmute
6	Press: Answer the current incoming call when there is an incoming call End the current call when there is call/dial-out Without incoming call: Display the last call information, press again to dial out Press and hold: End the current call when there is an incoming call Automatically dial out the last call number when there is no incoming call
7	Press: Decrease the volume, and unmute if muted



**WARNING**
**■ During driving**

During operation of buttons on steering wheel, extra care must be taken to avoid accidents.

## 6-1. Instrument information

# Head up display\*

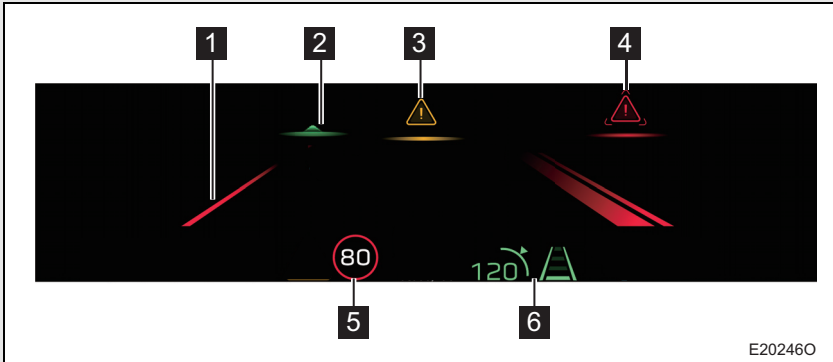
The head up display is linked with instrument panel and in-vehicle infotainment system, projecting driving information, navigation and driver assistance information onto the front windshield in front of the driver.



- 1** Lane departure warning (LDW)
- 2** Adaptive cruise control (ACC) following target
- 3** Front collision warning (FCW) first level warning sign (yellow for first level, red for second level)
- 4** Automatic emergency braking (AEB) warning sign
- 5** Road speed limit sign
- 6** ACC/SACC cruise speed information and time interval information

## Usage of head up display

### ■ ON/OFF of head up display

Method 1: Press HUD button on left side of instrument panel to turn on/off head up display.

Method 2: The on/off of head up display can be set in the display settings of in-vehicle infotainment system. (See P.195)

### ■ Head up display setting

Press and hold the HUD button on the left side of instrument panel or touch the head up display [Parameter adjustment] button in the display setting of in-vehicle infotainment system to enter the head up display parameter setting interface. The combination button on the right side of the multi-functional steering wheel can be used together with the virtual image of the head up display to set the height, brightness and tilt of the head up display.



## WARNING

### ■ Before using head up display

Check that the position and brightness of the virtual image on the head up display do not interfere with safe driving. Incorrect adjustment of the position or brightness of the virtual image can interfere with the driver's view and cause an accident, resulting in serious injury or even death.

### ■ During driving

During driving, do not continue staring at the head up display, otherwise you may not be able to see pedestrians and objects on the road in front of the vehicle.



## CAUTION

### ■ Prevent damage to components

- Do not place any liquid near the head up display projector. If the projector becomes wet, it may cause electrical failure.
- Do not place any items or stickers on the head up display projector. Otherwise, the display on the head up display may be interrupted.
- Do not touch the head up display projector or throw objects with sharp edges at the projector. Otherwise, it may cause mechanical failure.

### ■ High temperature protection

- When the temperature of the head up display projector is too high due to prolonged use of the head up display in direct sunlight, the system will automatically turn off for protection.

## 6-2. Driving specifications

# Driving the vehicle

**The following driving specifications must be observed to ensure safe driving.**

### ■ Driving

**Step 1** Sit in the driver seat and firmly depress the brake pedal.

**Step 2** Switch the shift lever to D position.

The "READY" indicator lamp on the instrument cluster will be illuminated.

**Step 3** Gradually release the brake pedal and gently depress the accelerator pedal to accelerate the vehicle.

### ■ Stop

**Step 1** When the shift lever is set to D position, depress the brake pedal.

**Step 2** If necessary, apply the EPB.

For long-term parking, be sure to set the shift lever to P or N position.

### ■ Parking

**Step 1** When the shift lever is set to D position, depress the brake pedal.

**Step 2** Press the P position button and set the shift lever to P position, to apply the EPB automatically.

**Step 3** After exiting the vehicle with the smart key, use the smart key to lock the vehicle (the vehicle will automatically power off).

## Starting on a steep slope

**Step 1** The driver fastens the seat belt, closes the doors, firmly depresses the brake pedal and sets the shift lever to D position.

Make sure the gear indicator lamp shows D.

**Step 2** Manually apply the EPB.

**Step 3** Release the brake pedal and gently depress the accelerator pedal.

---

### ■ During starting on an uphill slope

The Hill Hold Control (HHC) activates automatically to prevent the vehicle from slipping. (See P.309)

### ■ Emergency stop signal (ESS)

When a certain speed is reached, if emergency braking is applied, the brake lamp flashes quickly to remind the following vehicle until the brake pedal is released.

### ■ Driving in the rain

- When it rains, as visibility is reduced, windows fog up easily and the road is slippery, so drive with caution.
- When it rains, do not drive at a high speed because a water film will form between tires and road surface, hindering the normal operation of steering and braking.

### ■ Running in new vehicle

To extend the life of the vehicle, it is recommended that you observe the following precautions:

- Within the first 1,000 km:
  - Do not perform emergency stop.
  - Do not drive at a very high speed.
  - Do not accelerate suddenly.
  - Do not drive at a consistently low speed.
  - Do not drive at a constant speed for a long time.

### ■ Driving abroad

Please comply with the laws and regulations of the corresponding country or region.

 **WARNING****■ During start**

When the vehicle is in "READY" state and stopped, always depress the brake pedal with one foot. This will prevent the vehicle from moving unexpectedly.

**■ Precautions when driving**

- If you are not familiar with the position of brake pedal and accelerator pedal, do not drive to avoid depressing the wrong pedal.
  - If the accelerator pedal is accidentally depressed when the brake pedal should be depressed, sudden acceleration will be caused, which may lead to serious accidents.
  - Although the vehicle is equipped with reverse image system and parking radar system, please drive carefully during reversing.
  - During reversing, you may twist your body around, leading to a difficulty in operating the pedal. Make sure to operate the pedal correctly.
  - Even if move the vehicle slightly, you should keep the correct driving posture, so that you can depress the brake pedal and accelerator pedal accurately.
  - Depress the brake pedal with your right foot. Depressing the brake pedal with the left foot in an emergency may lead to delayed response, resulting in an accident.
- Do not drive over flammables or park near them.  
If there is any flammable material nearby, it may cause a fire.
- Do not move the vehicle backward when the shift lever is set to D or P position, or forward when the shift lever is set to R or P position; otherwise, it may cause accidents or damage the vehicle.
- Do not touch the one-button power off button during driving.  
If the vehicle power supply is set to OFF mode, the brake booster, etc. will not work normally.
- When going down a steep slope, be sure to slow down.  
Note that continuous application of the brake may cause brake overheating and failure.

 **WARNING**

- When the vehicle is parked on an inclined road, please make sure the slope is suitable for the EPB function, otherwise, please depress the brake pedal and apply the EPB to prevent the vehicle from moving forward or backward and causing an accident.
- Do not adjust the position of steering wheel, seat, interior or exterior rearview mirror during driving. Otherwise, it may cause accidents.
- Be sure to check that all occupants' arms, heads or other body parts are not stuck out of the vehicle; otherwise, serious personal injury may be caused.

■ **When driving on a slippery road**

- Emergency braking, acceleration and turns may cause wheel slippage and reduce the maneuverability of the vehicle, causing accidents.
- After passing through a puddle, gently depress the brake pedal to ensure normal brake function. Wet brake linings may impede normal braking. Even if only brake lining on one side gets wet, it can affect vehicle control.

■ **When operating the shift lever**

Be careful not to shift gears when depressing the accelerator pedal. Otherwise, the vehicle may be accelerated suddenly, thus causing accidents.

■ **When the vehicle stops**

- Do not leave the vehicle in "READY" state.  
If the shift lever is in a position other than P or N, the vehicle may accelerate suddenly, thus causing accidents.
- When the vehicle is in "READY" state, always depress the brake pedal and apply the parking brake when necessary to prevent accidents caused by the movement of the vehicle.
- If the vehicle is parked on a slope, to prevent an accident caused by the vehicle's movement forward or backward, be sure to depress the brake pedal and apply the parking brake firmly as necessary.



 **WARNING****■ After the vehicle is parked**

- Do not leave spectacles, lighters, sprayers or soft drink cans in the vehicle at a high temperature place; otherwise, the following unexpected circumstances may occur.
  - Gas leaks from lighters or sprayers, causing fires.
  - The interior temperature may deform or rupture the lenses and other plastic parts of spectacles.
  - A soft drink can may rupture, causing the beverage to spill onto interior trims of vehicle, and potentially causing a short circuit in electrical components of the vehicle.
- Be sure to apply the EPB, set the shift lever to P position, set vehicle power supply to OFF mode and lock the vehicle.
- Do not leave the vehicle when it is in "READY" state.
- When the vehicle power supply is turned on or just after it is turned off, do not touch the high-voltage parts in the front compartment, otherwise it may cause electric shock or burns.

**■ While napping in the vehicle**

Be sure to set vehicle power supply to OFF mode. Otherwise, you may accidentally move the shift lever or depress the accelerator pedal, causing an accident.

**■ When applying the brake**

- Drive carefully when the brake is wet.

When the brake is wet, the braking distance will increase, the braking effects on both sides of the vehicle may be different, and the parking brake may not hold the vehicle still.
- If the brake assist function is abnormal, do not follow other vehicles at close range, and avoid going down long slopes or sharp turns.

In this case, a greater force than usual is required to depress the brake pedal, and the braking distance may also increase.

 **CAUTION**

■ **During driving**

Do not use the accelerator pedal or depress the accelerator pedal and brake pedal at the same time to park on a slope.

■ **When parking**

For long-term parking, be sure to apply the EPB and set the shift lever to P position. Otherwise, it may cause the vehicle to move, or suddenly accelerate when the accelerator pedal is accidentally depressed.

■ **Driving performance**

- When the ambient temperature is too high or too low, the vehicle can start and drive normally, but the performance of the vehicle may be reduced.
- For new vehicles with the power battery in normal status, the driving range may fluctuate because of the driving habits (e.g., frequent acceleration and deceleration), road conditions (e.g., going up a long slope), ambient temperature (e.g., low temperature) and the turning on/off of the electrical equipment (e.g., A/C).

■ **Avoid damaging vehicle parts**

- Do not turn the steering wheel to the limit in either direction and keep it for a long time; otherwise, the power steering system will be damaged.
- During driving on a bumpy road, try to drive at a low speed to avoid damaging the wheels and bottom of the vehicle.

■ **In case of flat tire during driving**

Tire leakage or damage may cause the following conditions. Please hold the steering wheel firmly and slowly depress the brake pedal to reduce the speed of the vehicle:

- It may be difficult to control the vehicle.
- The vehicle will make abnormal sounds.
- The vehicle runs abnormally.

If tire goes flat or is damaged during driving, hold the steering wheel firmly, slowly depress the brake pedal to reduce the speed, and use tire repair kit in driver's tool for repair in time.

 **CAUTION****■ In case of water-logged road**

Do not drive on a road with deep water; otherwise, the vehicle may suffer from the following serious damage.

- The electrical components are short-circuited.
- The power system is damaged due to water immersion.

If water enters the vehicle after driving on a water-logged road, contact an authorized FAW Hongqi dealer as soon as possible to check the following items.

- Check whether the brake functions normally.
- Whether the level and the quality of the reducer oil have changed.
- The lubrication condition at the connections (possible parts) between the bearing and the suspension, and whether the functions of all connections, bearings, etc. are normal.

# Vehicle power supply mode

**Carry the smart key with you to switch vehicle power supply mode.**

- Switching vehicle power supply mode (vehicle power on/off)
- ▶ OFF mode

Method 1: In ON/ACC mode, use the remote control key to lock the vehicle to switch power supply mode to OFF mode.

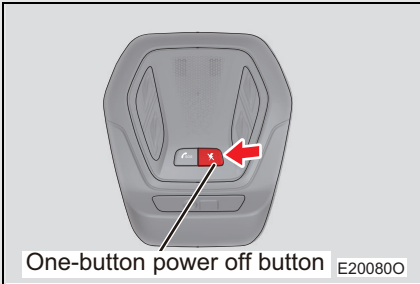

Method 2: In ON/ACC mode, press one-button power off button to switch power supply mode to OFF mode.

Hazard warning lamp can be used in OFF mode.

- ▶ ACC mode

In OFF mode, open the door to switch power supply mode to ACC mode.

In ACC mode, some electrical components (e.g. in-vehicle infotainment system) can be used.

- ▶ ON mode

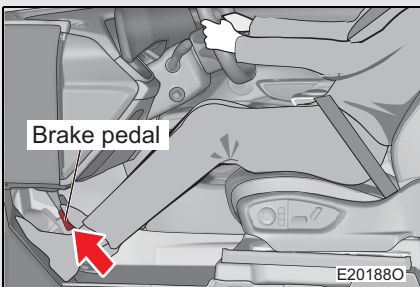

In OFF/ACC mode, depress the brake pedal to switch power supply mode to ON mode.

In ON mode, all electrical components can be used.

### ■ Auto vehicle power off

If there are no any operations within about 1 hour after parking, the vehicle will automatically power off. The ON/OFF of auto power off can be set in the energy settings interface of the in-vehicle infotainment system. (See P.188)

### ■ If the vehicle cannot be started

The vehicle anti-theft system may not be deactivated yet. (See P.69)

## WARNING

### ■ Precautions when driving

During driving, if you need to stop the power system in an emergency, press the one-button power off button for 3 consecutive times within 2 seconds or press and hold the one-button power off button for more than 3 seconds.

Do not touch the one-button power off button during driving, except in an emergency. If the power system is shut down during driving, it may cause accidents.

## CAUTION

### ■ Preventing a low 12 V battery

- When leaving the vehicle, the driver should lock the vehicle and carry the key. Do not leave the key in the compartment to prevent the PEPS from continuous operation, leading to low battery.

### ■ When the "READY" indicator lamp is off

- If the "READY" indicator lamp is still not illuminated after the correct start procedures of vehicle are performed, please contact the authorized FAW Hongqi dealer immediately.

## 6-2. Driving specifications

# Gearshift control

**Choose a gear suitable for driving conditions.**

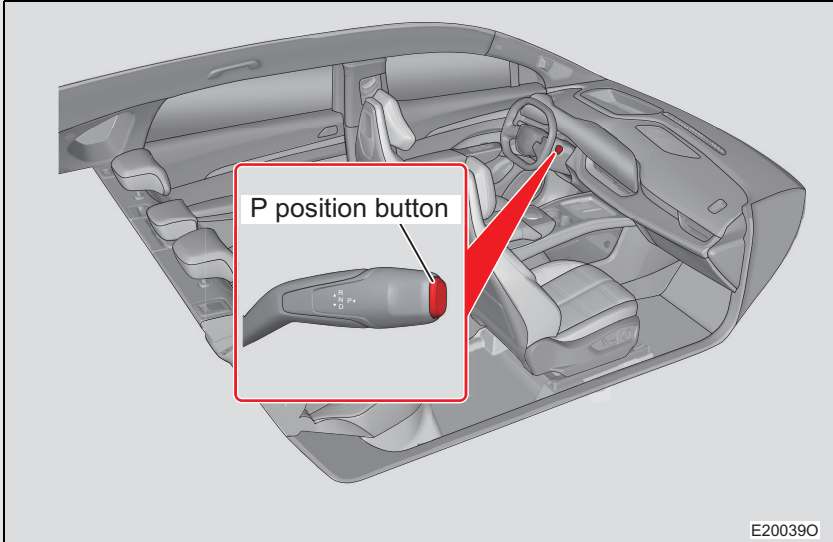

Gently operate the shift lever and make sure that the gearshifting is correct.

After each gearshifting, release the shift lever to reset it.

### ■ Gear shifting

When the vehicle power supply is set to ON mode, you can perform shift operations as follows.

- Switch from P to D: Depress the brake pedal and operate the shift lever downward to the second travel.
- Switch from P to N: Depress the brake pedal, and operate the shift lever upward to the first travel or downward to the first travel.
- Switch from P to R: Depress the brake pedal without depressing accelerator pedal, and operate the shift lever upward to the second travel.
- Switch from N to D: When the vehicle is stationary, depress the brake pedal, and operate the shift lever downward to the second travel.

- Switch from N to R: When the vehicle is stationary and the accelerator pedal is not depressed, depress the brake pedal and operate the shift lever upward to the second travel.
- Switch from D to N: Operate the shift lever upward to the first travel.
- Switch from D to R: Depress the brake pedal without depressing accelerator pedal until the vehicle is stationary, and operate the shift lever upward to the second travel. (When the vehicle is in D gear, the vehicle speed is higher than 8 km/h, operate the shift lever upward to the second travel, then the vehicle enters N gear)
- Switch from R to N: Operate the shift lever downward to the first travel.
- Switch from R to D: Depress the brake pedal until the vehicle is stationary, and operate the shift lever downward to the second travel. (When the vehicle is in R gear, the vehicle speed is higher than 8 km/h, operate the shift lever downward to the second travel, then vehicle enters N gear)
- Switch from N/D/R to P: Depress the brake pedal until the vehicle is stationary, and press the P position button.

When selecting the gear, ensure that the desired gear is displayed on the instrument cluster.

■ Gear/function

Gear	Function
P	Parking
R	Reverse
N	Neutral
D	Drive

## Gear description

### ▶ P (Parking) position

P position can prevent the wheels from rotating.

## WARNING

### ■ First operation of shift lever

This vehicle adopts electronic shift mechanism, which needs to be operated according to the gear information on the instrument cluster and the above gear operation description, and cannot be operated by intuition and consciousness to avoid danger.

### ▶ R (Reverse) position

When the shift lever is in R position, the vehicle can only move backwards. The vehicle must come to a complete stop before shifting to or out of R gear.

### ▶ N (Neutral) position

When in N gear, the motor drive system will be in servo state, and the wheels and drivetrain are not locked. During parking on a gentle slope, you should depress the brake pedal or apply the parking brake; otherwise, the vehicle may slide freely.

### ▶ D (Drive) position

D position is commonly used during driving, which controls the vehicle to move forward.

## P position button

### ■ When shifting to P position

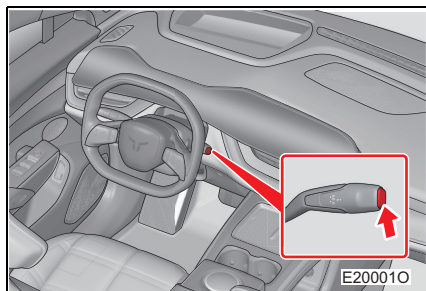

You can shift to P position by using the P position button.

When the vehicle is stationary, press the P position button.

When P gear is engaged, the gear information on the instrument cluster is displayed as P.



If the vehicle speed is higher than 3 km/h, it will be impossible to shift to P position.

- When shifting to another position from P position
  - Depress the brake pedal firmly, and operate the shift lever. If the shift lever is operated without depressing the brake pedal, the gear shifting is prohibited.
  - When changing gears, ensure that the gear information on the instrument cluster is displayed as the required gear.

---

■ **The vehicle will switch to P position automatically under the following conditions**

- When the vehicle power supply is set to OFF mode, the vehicle will automatically switch to P position.
- When the vehicle speed is lower than 3 km/h, if the driver unfastens the seat belt, releases the brake pedal and opens the door, the vehicle will switch to P position.
- When the vehicle is charging, it automatically switches to P position, and does not respond to any shift operations by the driver.

■ **Pedestrian warning system**

When the driver switched the gear to D or R, and the vehicle speed is 0-30 km/h, the pedestrian warning system will emit a warning sound. In D position, the sound level changes with the vehicle speed; In R position, the warning sound does not change.

The ON/OFF of pedestrian warning sound can be set in-vehicle infotainment system. (See P.193)



**WARNING**

■ **During driving on a slippery road**

Be careful during sudden acceleration and deceleration; otherwise, it may cause vehicle sideslip or wheel slipping.

## 6-2. Driving specifications

# Driving mode

This vehicle is equipped with a driving mode switching system which can provide 6 different driving modes: Economic, comfort, sport, snow, off-road and custom. In different modes, the vehicle has unique driving performance to meet the driving needs of driver.

### ■ Driving mode selection

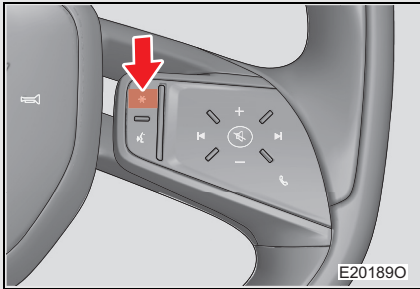

Method 1: \* button on steering wheel

After \* button on the steering wheel is set to "Driving mode switching" in the in-vehicle infotainment system, touch \* button on the steering wheel to switch driving mode. (See P.191)

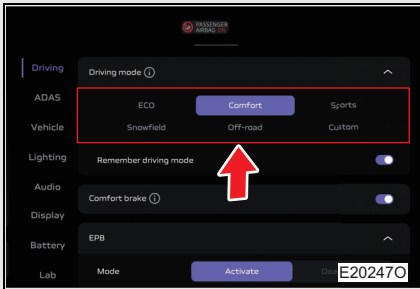

Method 2: Multimedia display

Six driving modes (economic, comfort, sport, snow, off-road and custom) can be selected through the driving settings interface of the in-vehicle infotainment system.

## Economic mode

In economic mode, the vehicle has good endurance and is suitable for common urban pavement.

### ■ Driving characteristics in economic mode

- Power output is gentle.
- For vehicles equipped with CDC shock absorber, the shock absorber is neither too hard nor too soft, providing relatively balanced road feel.

## Comfort mode

In comfort mode, the vehicle has good comfort and is suitable for common urban pavement.

### ■ Driving characteristics in comfort mode

- Power output is balanced.
- The steering feel is light.
- For vehicles equipped with CDC shock absorber, the shock absorber is relatively soft with high comfort.

## Sport mode

In sport mode, the vehicle has good power performance and is suitable for highways or common urban pavement.

### ■ Driving characteristics in sport mode

- Power output is strong.
- Movement sense is strong during turning.
- For vehicles equipped with CDC shock absorber, the shock absorber is relatively hard, providing strong road feel.

## Snow mode

The snow mode is applicable to low-adhesion roads such as ice, snow, slippery grass and gravel, etc.

### ■ Driving characteristics in snow mode

- The power output is stable and gentle, reducing vehicle skidding.
- The steering feel is light.
- For vehicles equipped with CDC shock absorber, the shock absorber is neither too hard nor too soft, providing relatively balanced road feel.

### Off-road mode

The off-road mode is suitable for urban road shoulders and light off-road pavements.

The off-road mode should be entered at relatively low vehicle speed. When the vehicle is running in off-road mode at a high speed, the driving mode will be automatically switched to all-terrain mode.

#### ■ Driving characteristics in off-road mode

- The power output is stable and gentle, reducing vehicle skidding.
- For vehicles equipped with CDC shock absorber, the shock absorber is neither too hard nor too soft, providing relatively balanced road feel.

### Custom mode

To satisfy the individual driving needs, in addition to the above driving modes, the driver can also choose a custom mode.

In custom mode, the user can set the acceleration mode, energy recovery level, braking mode, steering characteristics and suspension comfort.

Driving characteristics in custom mode can be set through the driving settings interface of the in-vehicle infotainment system. (See P.188)

---

#### ■ Setting conditions of driving mode switching

- Vehicle power supply is set to ON mode.
- This system and related systems have no fault.

#### ■ Working state of driving mode system

- When selecting the driving mode, the driver can know the current working condition of the driving mode system through the information displayed on the instrument cluster.

 **CAUTION****■ Precautions during switch of driving modes**

- To ensure driving safety, switch the driving modes during parking or driving at a low speed on good roads.
- The driving mode switching system has self-protection function. If operating conditions for the corresponding driving mode are not met, activating the driving mode may damage the vehicle and affect the driving safety. When the driver switches the driving mode, failure to switch to the target mode may be caused by the self-protection function of the system, which is normal.
- If the driving mode system still cannot work normally when operating conditions for the driving mode are met, immediately contact an authorized FAW Hongqi dealer to check the vehicle.
- Since the driving mode system cannot replace the driver's judgment on driving environment, the driver must always keep control of the vehicle and take full responsibility for the vehicle.

## 6-2. Driving specifications

# Air suspension\*

The vehicle can be maintained at different height levels by adjusting the driving mode or air suspension, thus making different ground clearances to achieve the better trafficability.

### Adjustment of air suspension

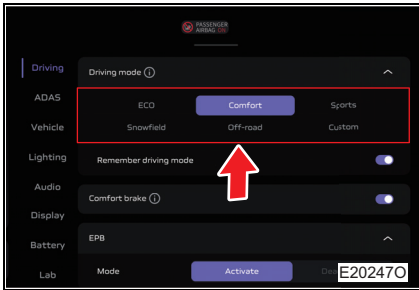

The vehicle height can be adjusted in the process of adjusting a driving mode, and it will also be automatically adjusted according to the driving mode and speed during driving. During the adjustment, the texts on the instrument cluster prompt the vehicle in lifting/lowering state. After the adjustment is completed, the instrument cluster displays the current height level.

### Air suspension height level

The air suspension has different height levels and damping characteristics by adjusting different driving modes.

- Air suspension characteristics in off-road mode:

In this mode, the vehicle height is automatically set to off-road height 2 (+ 50 mm).

This mode can be activated when the vehicle speed is less than 20 km/h. When the vehicle speed is more than 40 km/h, the driving mode is automatically adjusted from the off-road mode to the snow mode, and the vehicle height is decreased to off-road height 1 accordingly.

- Air suspension characteristics in snow mode:

In this mode, the vehicle height is automatically set to off-road height 1 (+ 25 mm).

When the vehicle speed is more than 80 km/h, the vehicle height will automatically decrease to normal level; when the vehicle speed is less than 40 km/h, the vehicle height will automatically return to off-road height 1.

**■ Air suspension characteristics in comfort mode:**

In this mode, the vehicle height is automatically set to normal level (+ 0 mm).

When the vehicle speed is greater than 100 km/h for more than 30 seconds, the vehicle height will automatically decrease to dynamic level; when the vehicle speed is less than 70 km/h for 120 seconds, the vehicle height will automatically return to normal level. When the vehicle speed is less than 35 km/h, the vehicle height will immediately return to normal level.

**■ Air suspension characteristics in sport/economic mode:**

In this mode, the vehicle height is automatically set to dynamic level (-15 mm).

When the vehicle speed is more than 140 km/h for 20 seconds, the vehicle height will automatically decrease to highway level (-30 mm); when the vehicle speed is less than 110 km/h for 20 seconds, the vehicle height will automatically return to dynamic level; when the vehicle speed is less than 35 km/h, the vehicle height will immediately return to dynamic level.

---

**■ When adjusting suspension**

- If the vehicle power supply is turned to OFF during the adjustment of suspension, the adjustment will be interrupted immediately until the vehicle power supply is turned to ON again, where the suspension will be automatically adjusted to the height corresponding to the current driving mode.
- If the current vehicle speed is not suitable for vehicle height adjustment, the vehicle height shall not be adjusted. Once the desired speed is reached, the vehicle will be automatically adjusted to the height corresponding to the driving mode.
- If any door is opened during adjustment of vehicle height, the adjustment will be interrupted immediately, and the suspension will be automatically adjusted to the height corresponding to the current driving mode after all door are closed.

 **WARNING**

■ **When parking, leave enough space above and below the body. Temperature fluctuations, load changes, vehicle height adjustment, etc., will change the vehicle height.**

■ **When the air suspension system fails, the warning lamp on the instrument cluster will come on with corresponding prompt message.**

Ignoring the warning lamp and prompt message may lead to an accident and personal injury.

If the air suspension system fails, please contact the authorized FAW Hongqi dealer to check the vehicle immediately.

 **CAUTION**

■ **Suspension height level failed to be adjusted normally**

When a certain driving mode is selected, in order to ensure the safety of occupants, the air suspension system will determine whether to respond to the request according to the current driving conditions. When the system determines that the current working conditions are not suitable for adjustment, the suspension will not be adjusted, which is normal.

## Lifting mode

The vehicle has a lifting mode, and if it is required to lift a single wheel or the whole vehicle, it should enter the lifting mode. After the lifting mode is entered, all air suspension adjustment functions will be disabled. When the maintenance is completed, you must exit the lifting mode.

■ **Entering lifting mode**

When vehicle power supply is set to ON mode, the lifting mode is turned on through the vehicle settings of the in-vehicle infotainment system (see P.191).

■ **Exiting lifting mode**

When vehicle power supply is set to ON mode, the lifting mode is turned off through the vehicle settings of the in-vehicle infotainment system (see P.191); When the vehicle speed is higher than 5 km/h, the vehicle exits lifting mode automatically.



**WARNING**

- If repairing the vehicle or getting underneath the vehicle, it is required to manually enter "lifting mode" to avoid injury.
- When using a trailer to transport the vehicle, it is required to manually enter "lifting mode" before transport, and then power it off.

**CAUTION**

- It is recommended to use manual mode to enter and exit lifting mode.

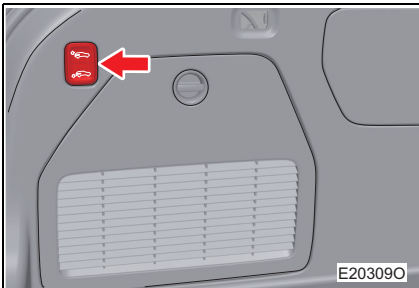
**Loading mode**

The vehicle has a loading mode, in which the vehicle height can be lowered to facilitate loading and unloading of goods.

- **Entering loading mode**

Close all doors, apply EPB, press the air suspension lowering button inside trunk lid to enter the loading mode.

- **Exiting loading mode**

Press the air suspension rising button in the trunk, close the trunk lid or release EPB to exit the loading mode; When the vehicle speed is more than 5 km/h, the vehicle will automatically exit the loading mode.

**CAUTION**

- When using the loading mode, leave enough space under the vehicle
- When exiting the loading mode, leave enough space above the vehicle and the opened trunk lid.

## 6-3. Operating lamps and wipers Headlamp switch

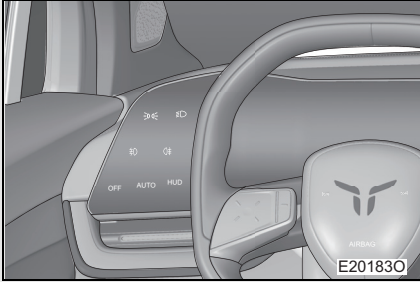

 The daytime running lamp, rear position lamp, license plate lamp and instrument panel backlight come on.

 The headlamp (low beam), position lamp, license plate lamp and instrument panel backlight come on.

**AUTO** The headlamp (low beam), position lamp, license plate lamp and instrument panel backlight come on and go out automatically.

**OFF** The daytime running lamp comes on.

### Turning on high beam

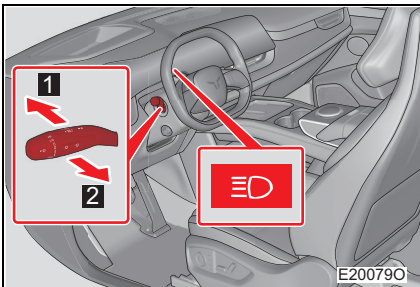

**1** When the headlamp (low beam) is turned on, push the lighting control lever forward to turn on the high beam; pull the lever back to its original position to turn off the high beam.

**2** Pull the lighting control lever backward to turn on the high beam; release the lighting control lever to turn off the high beam.

### ■ Daytime running lamp system

During daytime driving, to make your vehicle more visible to other drivers, if vehicle power supply is set to ON mode and the headlamps are off, the daytime running lamps will be turned on automatically.

### ■ Rain/light sensor

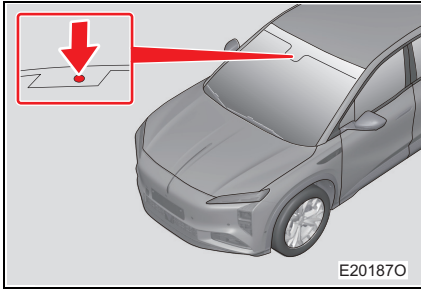

If an object is placed on the sensor or adherent matter on the windshield obscures the sensor, the sensor may work abnormally. The above situations will affect the sensor's detection on ambient light intensity, which may prevent the automatic headlamp and automatic wiper from working properly.

### ■ Automatic headlamp leveling system\*

The automatic headlamp leveling system can automatically adjust the headlamp beam height according to the number of occupants, the vehicle load and the road environment, so as to ensure that the headlamps can provide a good lighting angle for the driver.

### ■ Headlamp beam height control\*

After the headlamps are turned on, the headlamp beam height can be adjusted through the lighting settings interface of in-vehicle infotainment system according to the number of occupants and the vehicle load.

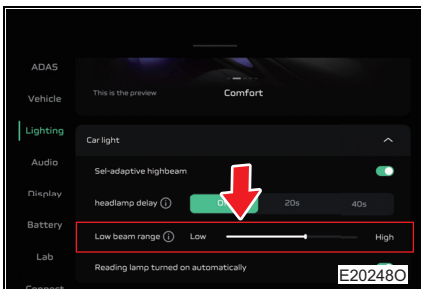

### Getting-off lighting system

When the vehicle power supply is in ON mode and the low beam is on, the lamp continues to illuminate for a period of time after the vehicle power supply is switched to OFF mode and then automatically goes off. The ON/OFF and duration of getting-off lighting can be set through the lighting settings interface of the in-vehicle infotainment system. (See P.192)

### Boarding lighting system

Unlock the vehicle when the lamp switch is in the automatic headlamp position. If the automatic headlamp on condition is met at this time, the lamp will be on for a period of time and then go out automatically. The ON/OFF and duration of boarding lighting can be set through the lighting settings interface of the in-vehicle infotainment system. (See P.192)

### Corner lamp

When the vehicle runs at a low speed with the headlamps turned on, if the driver operates the turn signal lamp switch or steering wheel for turning, the corner lamp on the corresponding side will automatically come on to assist the driver in driving. When the R gear is engaged, if the driver operates the turn signal lamp switch or steering wheel for turning, the corner lamps on both sides of the vehicle will come on at the same time to improve the lighting effect of surrounding area during reversing.



---

### ■ Lamp fogging

In the event of rain or vehicle wash, the interior of headlights, taillights and turn signal lamps may temporarily mist up. This is caused by cold condensation of water vapor on the inner surface of the lens when the temperature inside the lamp is significantly higher than the ambient temperature or when the ambient humidity is high (similar to fogging of window glass), and it will frost when the temperature is too low. This is a normal physical phenomenon that does not affect the function or life of the lamps.

When fog appears on the lamps, park the vehicle in a dry, ventilated place with suitable temperature, and the fog or frost will gradually reduce until it disappears; When the vehicle is driving or there is sunlight, the fog will dissipate faster. However, if you see a large amount of water or water droplets inside the lamp, please contact an authorized FAW Hongqi dealer for inspection of the vehicle.

# Intelligent high beam control (IHC)\*

The IHC can automatically turn on and off the high beams according to the judgment of the multifunction camera. When the IHC is turned on, indicator lamp  on the instrument cluster comes on. When the vehicle speed is higher than 50 km/h, if high beam ON conditions are met, the IHC is activated, and the high beam indicator lamp  (blue) on the instrument cluster comes on; When the vehicle speed is lower than 30 km/h, the IHC is in standby state and the high beam indicator lamp  (blue) on instrument cluster goes out.

### Enabling/disabling IHC

The IHC can be enabled and disabled through the lighting settings interface of the in-vehicle infotainment system. (See P.192)

### Operating conditions of IHC

Conditions for automatically turning on or off high beams

- The high beams will be automatically turned on when all the following conditions are met:
  - Headlamp switch is set to AUTO position and low beam lamp comes on.
  - The high beam switch handle is in the "high beam off" position.
  - Turn on IHC.
  - The vehicle speed is higher than about 50 km/h.
  - The area in front of the vehicle is dark.
  - There is no vehicle with all headlamps or tail lamps turned on in front.
- The high beams will be automatically turned off when any of the following conditions is met:
  - Headlamp switch is set to a position other than AUTO.
  - Turn off IHC.
  - The vehicle speed is less than about 30 km/h.
  - The area in front of the vehicle is not dark.
  - All headlamps or tail lamps of a vehicle ahead are turned on.

- Under the following circumstances, the system may not accurately detect the ambient brightness level, which may prevent the IHC from working properly. In this case, switch between high beam and low beam manually:
  - The front windshield is blurred by moisture, ice, dirt, etc.
  - The front windshield is broken or damaged.
  - The front view is unclear due to fog, heavy rain, snow and other reasons.
  - The camera is deformed or dirty.
  - The camera temperature is extremely high.
  - The ambient brightness is equivalent to the brightness of headlamps, tail lamps or fog lamps.
  - The headlamps or tail lamps of vehicle ahead are turned off, dirty, discolored or incorrectly aimed, or one of them is turned on.
  - The vehicle runs through an area with intermittent changes in brightness.
  - The vehicle runs on uphill and downhill roads, bumpy roads or uneven roads (e.g. stone-paved roads, and gravel roads) frequently or repeatedly.
  - The vehicle makes turns or runs on winding roads frequently or repeatedly.
  - There are highly reflective objects in front of the vehicle, such as signs or mirrors.
  - The back of vehicle ahead is highly reflective, such as a container on the truck.
  - The headlamps of the vehicle are damaged, dirty or incorrectly aimed.
  - The headlamps of opposite vehicle are turned off and its fog lamps are turned on.
  - The vehicle is inclined due to flat tire, towing a trailer, etc.
  - The high beam and low beam are switched repeatedly in an abnormal way.
  - There is a lamp similar to the headlamps or tail lamps in front of the vehicle.
  - Wet roads, snow roads, ice roads, etc. are reflective.



**WARNING**

- **Do not rely on the automatic high beam too much. Be sure to drive safely, observe the surrounding environment, and turn on or off the high beam manually if necessary.**



## 6-3. Operating lamps and wipers

# Turn signal lamp control lever

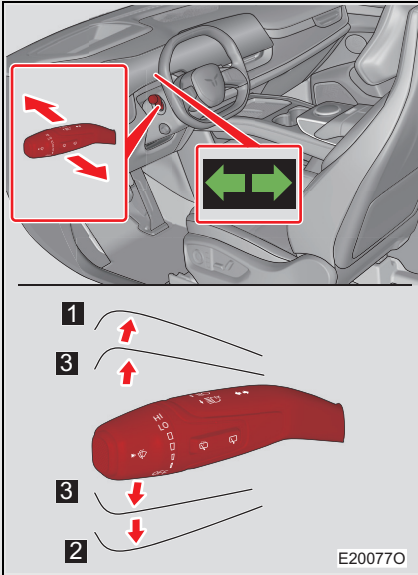

- 1 Right turn
- 2 Left turn
- 3 Comfort flashing

When the control lever is set to non-self-locking position once, the left/right turn signal lamp will flash three times; when the control lever is set to non-self-locking position continuously, the left/right turn signal lamp will flash continuously until the control lever is released.

### ■ Operating conditions of turn signal lamps

Vehicle power supply is set to ON mode.

### ■ Control of turn signal lamp and hazard warning lamp

When the turn signal lamp is on, if the hazard warning lamp switch is pressed, the left and right turn signal lamps will flash at the same time; if the hazard warning lamp switch is pressed again, the turn signal lamp will return to the working state.

When the hazard warning lamp is on and vehicle power supply is set to ON mode, if the turn signal lamp is turned on, the turn signal lamp will work, and the hazard warning lamp will stop working; if the turn signal lamp is turned off, the hazard warning lamp will return to the working state.

## 6-3. Operating lamps and wipers

# Fog lamp switch

The fog lamps improve visibility under unfavorable driving conditions, such as rainy days or fogging.

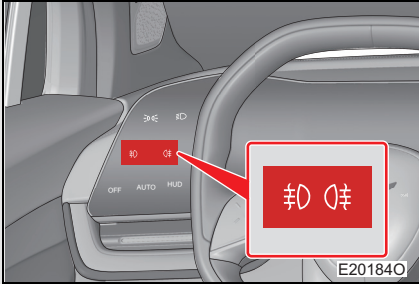

Touch the fog lamp switch to turn on the fog lamp, touch the switch again to turn off the fog lamp.

### ■ Operating conditions of fog lamp

Vehicle power supply is set to ON mode and headlamp is turned on.

# Front windshield wiper & washer

When the wiper control lever is in **AUTO** position, the wiper will automatically work if the rain/light sensor detects rain. The system automatically adjusts the wiper speed according to the rainfall and vehicle speed.

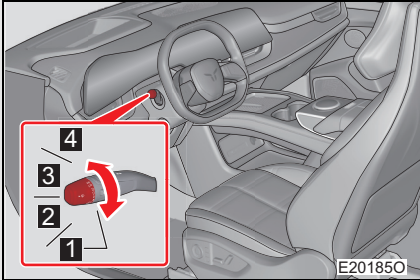

- 1** OFF - The wiper is turned off.
- 2** AUTO position - The wiper speed is automatically adjusted according to the rainfall.

There are four adjustment levels in AUTO position

- 3** LO position - The wiper works at a low speed.
- 4** HI position - The wiper works at a high speed.

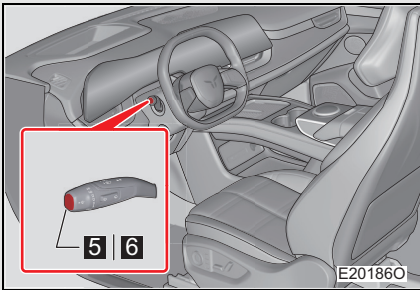

- 5** MIST position - The wiper works at a low speed for 1 cycle.

Press the washing button on the wiper control lever to the first travel, and the wiper works at a low speed for 1 cycle.

- 6** Cleaning/wiping operation. Press the washing button on the wiper control lever to the second travel to clean the front windshield.

■ **Operating conditions of front windshield wiper & washer**

The vehicle power supply is set to ON mode and the front compartment cover is closed.

■ **Rain/light sensor**

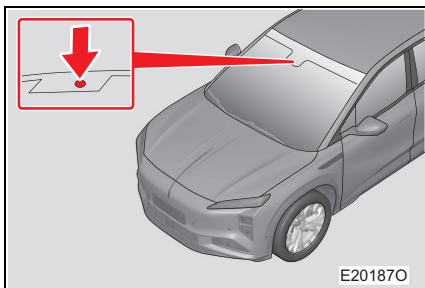

The rain/light sensor determines the amount of rain.

■ **If the windshield washer fluid cannot be sprayed out**

Check whether there is washer fluid in the windshield washer fluid reservoir.  
Check that the washer nozzle is not blocked.

■ **If the front windshield wiper blade needs to be replaced**

- When the wiper control lever is in OFF and front compartment cover is closed with the vehicle stationary, set the wiper to the service position through the vehicle settings interface of the in-vehicle infotainment system (see P.191).
- Turn off vehicle power supply and switch the wiper control lever to MIST position within 10 seconds to set the wiper to the service position.
- When the wiper is in the service position, set vehicle power supply to ON mode, and move the wiper control lever to a position other than MIST position or disable the wiper service position through the vehicle settings interface of in-vehicle infotainment system or the vehicle switches from stationary status to driving status, to exit the service position.

 **WARNING****■ Warnings for using front windshield wiper in AUTO mode**

In AUTO mode, the front windshield wiper may work unexpectedly if the sensor is touched, the interior rearview mirror is pulled with force or the front windshield is strongly vibrated (for example, the front windshield is knocked with force). Be careful that your fingers or anything else are not pinched by the front windshield wiper.

**■ Precautions for use of washer fluid**

In cold weather, do not use the washer fluid before the front windshield is warmed. The washer fluid may freeze on the front windshield, resulting in reduced visibility. This may cause an accident that could result in serious injury or even death.

**■ Only the windshield washer fluid can be placed in the washer fluid reservoir**

It is dangerous to use coolant as washer fluid. If it is sprayed onto the windshield, it will stain the windshield, which could obstruct your view and may cause an accident.

**■ In freezing weather, always use windshield washer fluid mixed with antifreeze**

It is very dangerous to use windshield washer fluid without antifreeze in freezing weather, because it may freeze on the windshield, obstructing your view and thus causing an accident. In addition, before spraying washer fluid, make sure to fully heat the windshield with the defroster.

**■ The wiper blade should be replaced in time**

The use of worn or dirty wiper blade will greatly reduce the clarity of the front view and affect the driving safety. Therefore, it is necessary to replace the damaged or worn and inoperative wiper blade in time.



**CAUTION**

■ **When the front windshield is dry**

Do not use the wiper; otherwise, the wiper blade may be damaged.

■ **When the washer fluid cannot be sprayed out of the nozzle**

If the washing button on the wiper control lever is pressed for a long time, it may cause damage to the washer fluid pump.

■ **When the nozzle is blocked**

Do not use needles or other objects to remove foreign matters without permission; otherwise, the nozzle will be damaged.

## 6-3. Operating lamps and wipers

# Rear windshield wiper & washer

The wiper and washer can be operated by pressing rear wiper control button.

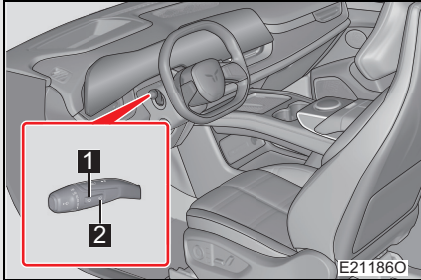

- 1** Cleaning operation.  
Press the rear windshield washing button to clean the rear windshield.
- 2** Wiping operation.  
Press rear windshield wiper button, rear windshield wiper starts operation; Press it again, rear windshield wiper stops operation.

### ■ Operating conditions of rear windshield wiper & washer

The vehicle power supply is set to ON mode and the back door is closed.

### ■ Automatic wiping in R gear

When the front windshield wiper is working, the rear windshield wiper is automatically turned on after the R gear is shifted.

### ■ If the windshield washer fluid cannot be sprayed out

Check whether there is washer fluid in the windshield washer fluid reservoir.  
Check that the washer nozzle is not blocked.

### **WARNING**

#### ■ It is forbidden to use windshield washer fluid containing more than 60% ethanol

In a high temperature environment, the windshield washer fluid containing more than 60% ethanol can corrode the rear decorative lamps, causing them to crack.



**CAUTION**

■ **When the rear windshield is dry**

Do not use the wiper; otherwise, the wiper blade may be damaged.

■ **When the washer fluid cannot be sprayed out of the nozzle**

If the washing button on the wiper control lever is pressed for a long time, it may cause damage to the washer fluid pump.

■ **When the nozzle is blocked**

Do not use needles or other objects to remove foreign matters without permission; otherwise, the nozzle will be damaged.



## 6-4. Using driver assistance system

# Adaptive cruise control (ACC)\*

ACC can comprehensively control the vehicle speed and the distance to the target vehicle within the speed range of 30 ~ 120 km/h, thus reducing the driver's burden and enhancing driving comfort. In addition, the system can automatically switch between cruise control and following cruise control based on the presence of a moving vehicle ahead. Because the actual driving environment is complex, in some cases, the driver can also intervene with the vehicle at any time as needed, and actively control the distance between the vehicle and the target vehicle. If necessary, ACC will prompt the driver by audible and visual alarms.

If ACC detects that the distance to the vehicle ahead is less than the set following distance, this vehicle automatically decelerates; if the vehicle ahead accelerates or leaves the lane, the vehicle can accelerate to the set cruising speed.

### ACC setting

- Turn on the cruise

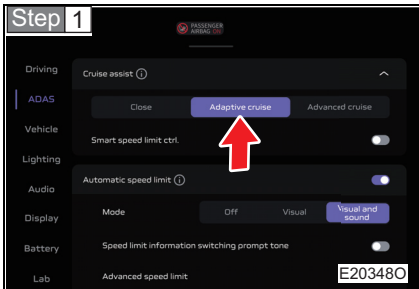

The cruise function can be turned on through the driver assistance settings interface of the in-vehicle infotainment system and set to ACC.

The cruise mode can only be set when the system is inactivated.

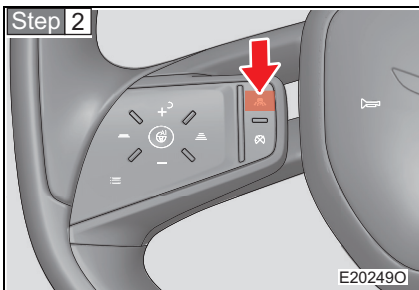

When ACC white indicator lamp on the instrument cluster comes on, accelerate or decelerate to the desired vehicle speed, then press the left side cruise ON button on the steering wheel, the ACC green indicator lamp comes on, and the current vehicle

### ■ Adjusting vehicle speed

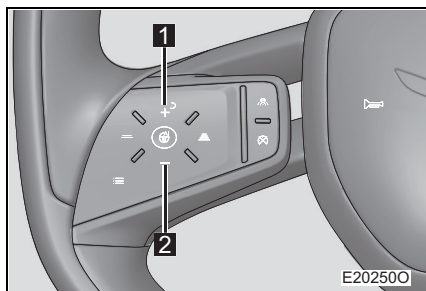

#### 1 Increasing vehicle speed

**Press:** Each time it is pressed, the vehicle speed increases by 5 km/h;

**Press and hold:** After the system confirms that the pressing and holding is valid, the vehicle speed will increase by 1 km/h continuously.

#### 2 Reducing vehicle speed

**Press:** Each time it is pressed, the vehicle speed decreases by 5 km/h;

**Press and hold:** After the system confirms that the pressing and holding is valid, the vehicle speed will decrease by 1 km/h continuously.

**Note:** If the currently set vehicle speed is not a multiple of 5 when the button is pressed, it will automatically change to a multiple of 5 at first during adjustment.

### ■ Setting following distance

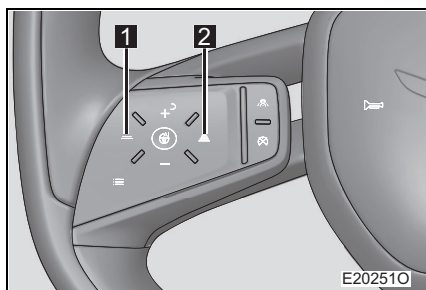

#### 1 Decreasing following distance

#### 2 Increasing following distance

The system provides four distance modes. Each time the control button is pressed, one mode is switched.

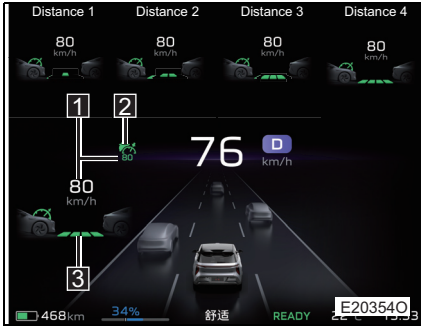

- 1 Set cruising speed**
- 2 ACC indicator lamp**  
White: The system is enabled, the set conditions are met, and cruise control setting can be carried out.  
Green: The system is working, and the cruise control mode is entered.
- 3 Set following distance**  
The default following distance is "Distance 4".

## Canceling and resuming ACC

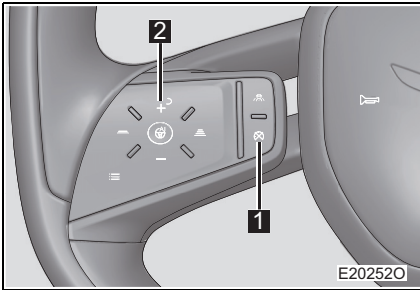

- 1 Cancel**  
Depress the brake pedal or press the left side cruise cancel button on the steering wheel to cancel cruise control.
- 2 Resume**  
To resume the cruise control and return to the set speed, press the left side cruise speed increase button on the steering wheel to resume it.

### ■ Noise during automatic deceleration by ACC

During automatic deceleration by ACC, noise may occur, which is normal.

### ■ Following distance

The following distance is "Distance 4" by default.

### ■ Setting conditions of cruise control

- The ESC is enabled.
- All doors and the front compartment cover are closed.
- The driver has fastened the seat belt.
- The D gear is engaged.
- The driver does not depress the brake pedal.
- The ADAS cameras are not blocked and function properly.
- ACC/ESC/AEB/TCS/ABS has no fault.
- AEB/APA is not activated.

- The vehicle is in sport/economic/comfort driving mode.

### ■ **Conditions for suspending cruise**

- When overtaking, depress the accelerator pedal deeply and briefly for no more than 1 minute and resume ACC after releasing the accelerator pedal.

### ■ **Conditions for canceling cruise control**

- Press the left side cruise cancel button on the steering wheel.
- Depress the brake pedal or apply the EPB.
- Open any door or the front compartment cover.
- The driver unfastens the seat belt.
- Depress the accelerator pedal for more than 1 minute.
- Set the shift lever to a position other than D.
- ABS/TCS/ESC is activated.
- AEB/APA is activated.
- The relevant function of the system fails.

### ■ **ACC fault**

In the event of an alarm due to ACC fault, please contact an authorized FAW Hongqi dealer for vehicle inspection.

### ■ **After setting vehicle power supply to OFF mode**

After the vehicle power supply is set to OFF mode, the set cruising speed or following distance will be deleted.

### ■ **Adjusting or calibrating ACC**

Adjust or calibrate the ACC under the following conditions, otherwise the ACC may not work properly:

- The front windshield is damaged or replaced.
- The ADAS camera unit or forward millimeter wave radar mounting bracket is removed and then refitted.
- The four wheels are aligned.
- The front bumper is hit or deformed.

Contact an authorized FAW Hongqi dealer.

 **WARNING**

- **To ensure driving safety, it is recommended that the set cruising speed should not exceed 120 km/h. It is very dangerous to use the cruise control during high-speed driving, so the driver is recommended to drive actively.**
- **Prevent accidental activation of ACC**  
When this function is not used, deactivate the cruise control.
- **Situations where ACC should not be used**  
To avoid the possibility of losing control of the vehicle and causing serious injury or death, do not use the ACC under any of the following conditions:
  - Traffic jams.
  - Complicated road conditions.
  - Sharp turns.
  - Winding roads.
  - Slippery roads (such as roads covered with rain, ice or snow).
  - Steep slopes.
  - There is a stationary obstacle in front of the vehicle.
  - Weather such as snow, rain, ice and dense fog.
  - Poor road lighting at night.
  - When strong light shines on the camera.
  - When there are significant height changes in the road.
- **The driver is the primary controller of the vehicle, whose control on the vehicle takes precedence over the ACC. Even if the vehicle is in ACC mode, when the driver depresses the accelerator pedal or brake pedal, the vehicle will be under the control of the driver. The driver must always keep control of the vehicle and take full responsibility for the vehicle.**
- **ACC is only a driver assistance system. If necessary, the driver should immediately deactivate the ACC and drive by himself/herself. When using ACC, please comply with relevant local laws and regulations, and adapt to the traffic, road and weather conditions at that time.**
- **The front windshield shall not be modified or covered by any auxiliary equipment. Otherwise, the ACC may not work properly.**
- **When leaving the driver seat for a long time, be sure to disable the ACC to avoid accidents caused by misoperation.**
- **When this vehicle follows the target vehicle for driving, the ACC mainly controls the following distance, and the actual speed of this vehicle may be lower than the set cruising speed.**

 **WARNING**

- If the distance from the vehicle ahead becomes too close (for example, due to the sudden emergency braking of the vehicle ahead) in ACC mode, the system will prompt the driver through audible and visual alarms via the instrument cluster, and the driver should pay attention to the distance and take control of the vehicle at this time.
- When the driver depresses the accelerator pedal for active acceleration, the cruising speed icon displayed on the instrument cluster multifunction display will flash, which is normal. At the same time, when the driver presses left side  $+P$  button on the steering wheel immediately after releasing accelerator pedal, the current vehicle speed can be set as the target cruising speed.
- When this vehicle enters or exits a curve or changes the lane, or when the vehicle ahead is stationary, the ACC may lose the target vehicle or misidentify the target vehicle.
- The ACC cannot detect other sides than tail of the vehicle, children, pedestrians, animals or other objects or apply the brake for them. At this time, the driver must drive carefully.
- The ACC has limited braking capacity. It may have no time to slow down to avoid a collision with the vehicle ahead when the vehicle ahead suddenly decelerates, stops or enters your lane. If a danger is felt, please actively depress the brake pedal for braking.
- During driving, the driver must remain fully attentive and always be prepared to take action and apply brake.
- The driver should adjust the following distance and reasonably set the ACC according to the traffic ahead and the current weather conditions (such as rain and snow). The driver needs to ensure that the vehicle can be decelerated to a stop within their field of view at all times.
- The ACC can only identify motor vehicles (such as vehicles and trucks) with legal license plates that are capable of driving on highways.  
If vehicle ahead has characteristics of irregular shape, modification, painted surface, etc., the recognition effect cannot be guaranteed. The recognition of pedestrians and narrow vehicles (such as bicycles and motorcycles) cannot be guaranteed either. At this time, the driver should be prepared to take control of the vehicle at any time according to the actual situation.

 **WARNING**

- The ACC may not accurately recognize large trailers. At this time, the driver should take over the vehicle at any time according to the actual situation.
- The ACC cannot accurately determine the passing width of the lane ahead. Therefore, if the driver feels that the front lane is too narrow for normal passage, they immediately deactivate the ACC through braking intervention and control the vehicle.
- Do not use the ACC on steep slopes. The ACC may not detect vehicles in the same lane, so the driver usually needs to control the acceleration and braking of the vehicle. If the brake is applied, the ACC will be deactivated.
- When a vehicle traveling in the same direction in the same lane is detected, a symbol of vehicle ahead will be displayed on the instrument cluster. If this symbol indication is inconsistent with the actual situation observed by the driver, the driver is responsible for taking over the vehicle and driving according to the actual situation.
- If a foot is placed on the accelerator pedal, the ACC may not automatically apply the brake, resulting in a collision with the vehicle ahead, so the driver should keep focused.
- The front bumper must not be painted, modified or covered by any auxiliary equipment. Otherwise, the performance of forward millimeter wave radar sensors may degrade or fail!
- Severe extreme weather conditions such as heavy snow, rain, ice and fog may lead to the performance degradation or failure of forward millimeter wave radar sensors. In such weather, the driver must disable the ACC.
- If the forward millimeter wave radar sensors are displaced due to collision, the ACC may degrade or fail. The driver shall calibrate the forward millimeter wave radar sensors in time.
- Do not use forward millimeter wave radar sensors that are incorrectly calibrated.
- When vehicles in the adjacent lane move in front of the direction of travel of this vehicle, if they do not enter the monitoring area, they could not be detected, thus resulting in a response lag of ACC. The driver should pay close attention to movements of vehicles in the adjacent lane and take the initiative to intervene when necessary.



**WARNING**

- **If the vehicle ahead brakes suddenly (for emergency stop), the ACC may be unable to react or react too slowly, thus resulting in a risk of delayed braking. In this case, the driver may not receive a takeover request. The driver should keep focused, and take the initiative to intervene when necessary.**
- **When this vehicle follows the target vehicle and stops in ACC mode, it may start suddenly due to the blocked target vehicle, pedestrians passing by, etc. The driver should keep focused, and take the initiative to intervene when necessary.**



 **CAUTION**

■ The ACC will control this vehicle at the set following distance from the target vehicle. If the target vehicle decelerates or stops, the ACC will control this vehicle to decelerate or stop automatically.

■ When the target vehicle restarts or leaves the lane after stopping for no more than 3 seconds, this vehicle will start automatically under the control of ACC.

■ When the target vehicle restarts or leaves the lane after stopping for more than 3 seconds but no more than 10 minutes, a message to resume cruise control will be shown on the instrument cluster multi-function display of this vehicle, and the driver can resume the ACC by gently depressing the accelerator pedal or pressing left side  $+^{\circ}$  button on the steering wheel, thus realizing automatic starting. At this time, the driver should pay attention to the front traffic conditions, so as to determine whether the vehicle can be safely started.

■ When this vehicle stops for more than 10 minutes, the ACC will be automatically deactivated.

■ The ACC cannot keep the vehicle braked for a long time. Do not leave the vehicle when the ACC keeps the vehicle stopped. Before leaving the vehicle, be sure to engage the P gear.

■ During driving through a curve with ACC, pay attention to the followings:

- In sharp curves, the ACC may be deactivated or limit the speed.

- On curves, the ACC may respond to vehicles in another lane, have no time to respond to vehicles in the same lane, make the vehicle collide with the front, or lose control of the vehicle; especially during driving on ramps, the ACC may lose its target due to large curve, thus causing acceleration. On curves, the driver must take extra care and always be ready for braking when necessary. During driving on curves, choose a proper speed.

■ When this vehicle passes through an intersection with traffic lights while following the vehicle ahead, the driver should pay attention to the change of traffic lights and actively intervene with the vehicle when necessary to avoid violating traffic rules.

■ When this vehicle is in dense fog, rain, snow and other weather, or when there are frost and dirt marks on the ADAS camera lens, or when this vehicle is driving towards the sun (or strong light source), a message "IFC is blocked, please clean the windshield" may be displayed on the instrument cluster due to "Limited field of view" of camera, and the ACC cannot work at this time.

## 6-4. Using driver assistance system

# Super adaptive cruise control (SACC)\*

Based on the ACC, SACC not only perform cruise and following functions, but also identify the lane markings through the ADAS camera. It can control the vehicle to drive along the center line of the lane, enhancing both driving comfort and safety.

If SACC detects that the distance to the vehicle ahead is less than the set following distance, this vehicle automatically decelerates; if the vehicle ahead accelerates or leaves the lane, the vehicle can accelerate to the set cruising speed.

### SACC setting

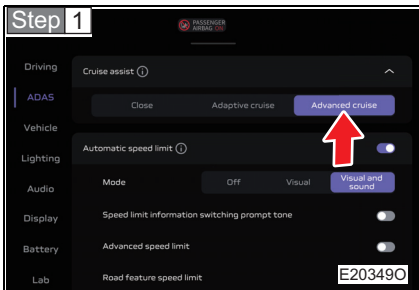

The cruise function can be turned on through the driver assistance settings interface of the in-vehicle infotainment system and set to SACC.

The cruise mode can only be set when the system is inactivated.

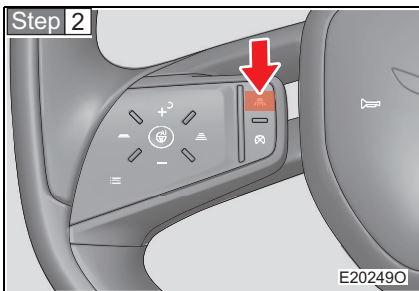

When SACC white indicator lamp on the instrument cluster comes on, accelerate or decelerate to the desired vehicle speed, then press the left side cruise ON button on the steering wheel, the SACC green indicator lamp comes on, and the current vehicle speed can be set as the cruising speed.

## ■ Adjusting vehicle speed

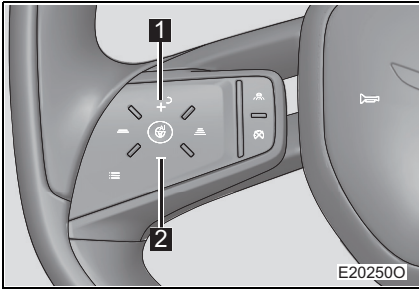

### 1 Increasing vehicle speed

**Press:** Each time it is pressed, the vehicle speed increases by 5 km/h;

**Press and hold:** After the system confirms that the pressing and holding is valid, the vehicle speed will increase by 1 km/h continuously.

### 2 Reducing vehicle speed

**Press:** Each time it is pressed, the vehicle speed decreases by 5 km/h;

**Press and hold:** After the system confirms that the pressing and holding is valid, the vehicle speed will decrease by 1 km/h continuously.

**Note:** If the currently set vehicle speed is not a multiple of 5 when the button is pressed, it will automatically change to a multiple of 5 at first during adjustment.

## ■ Setting following distance

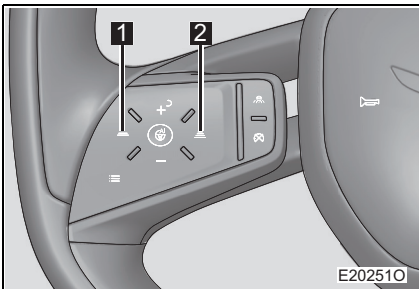



### 1 Decreasing following distance

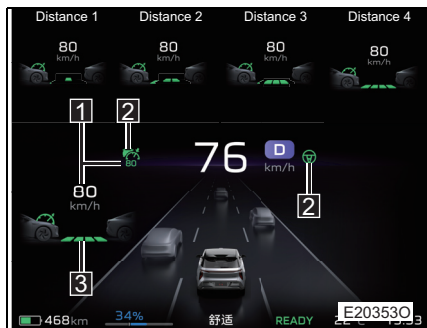

### 2 Increasing following distance



The system provides four distance modes. Each time the control button is pressed, one mode is switched.





- 1 Set cruising speed
- 2 SACC indicator lamp

 (Off)  (off): System is in standby and does not meet the setting conditions.

 (Off)  (white): System turns on and ACC setting can be performed.

 (White)  (white): System turns on and SACC setting can be performed.

 (Off)  (green): System operates and enters ACC mode.

 (Green)  (green): System operates and enters SACC mode.

- 3 Set following distance  
The default following distance is "Distance 4".

## Canceling SACC

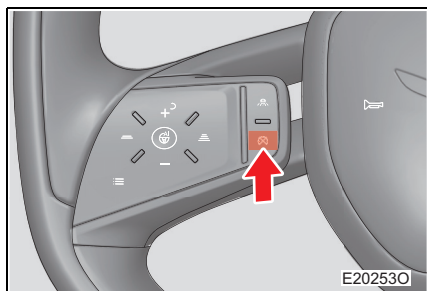

Depress the brake pedal or press the left side cruise cancel button on the steering wheel to cancel cruise control.

---

### ■ Switching between SACC and ACC

When ACC is working and SACC setting conditions are met, press the cruise ON button to switch to SACC mode.

When SACC is working, the driver presses the cruise ON button to switch to ACC mode.

When SACC is working, the system detects that both hands have been off the steering wheel for a certain period of time, it will automatically switch to ACC mode.

### ■ Noise during automatic deceleration by SACC

When SACC performs automatic deceleration, noise may be produced, which is normal.





### ■ Following distance

The following distance is "Distance 4" by default.

### ■ Setting conditions of SACC

- The cruise mode is set to SACC in the in-vehicle infotainment system.
- All doors and the front compartment cover are closed.
- The driver has fastened the seat belt.
- The D gear is engaged.
- The brake pedal is not depressed.
- The ADAS cameras are not blocked and function properly.
- The lane markings are clear and meet the requirements of national standards.
- SACC/ESC/AEB/TCS/ABS/EPS has no fault.
- AEB/APA is not activated.
- The vehicle is in sport/economic/comfort driving mode.

### ■ Conditions for suspending SACC

- When overtaking, depress the accelerator pedal deeply and briefly  (flashing) for no more than 1 minute or operate the steering wheel  (flashing) for no more than 0.5 minute to suspend SACC, release the accelerator pedal, SACC will resume after the vehicle is centered in the lane and the steering wheel is straightened.
- When SACC is working, if camera fails to recognize the lane markings ahead,  (flashing) it will automatically switch to ACC mode. After the camera recognizes the lane markings ahead, SACC will resume.
- When SACC is working, if a sharp curve suddenly appears,  (flashing) it will automatically switch to ACC mode. After the vehicle runs over the sharp curve, SACC will resume.
- When SACC is working, if camera detects that the lane is too wide or too narrow,  (flashing) it will automatically switch to ACC mode. After the camera recognize a suitable lane ahead, SACC will resume.

### ■ Conditions for canceling SACC

- Press the left side cruise cancel button on the steering wheel.
- Depress the brake pedal or apply the EPB.
- Open any door or the front compartment cover.
- The driver unfastens the seat belt.
- Depress the accelerator pedal for more than 1 minute.
- Set the shift lever to a position other than D.
- ESC is turned off.
- ABS/TCS/ESC is activated.
- AEB/APA is activated.
- The relevant function of the system fails.

### ■ SACC fault

In the event of an alarm due to SACC fault, please contact an authorized FAW Hongqi dealer for vehicle inspection.

### ■ After setting vehicle power supply to OFF mode

After the vehicle power supply is set to OFF mode, the set cruising speed or following distance will be deleted.

### ■ Adjusting or calibrating SACC

Adjust or calibrate the SACC under the following conditions, otherwise the SACC may not work properly:

- The front windshield is damaged or replaced.
- The ADAS camera unit or forward millimeter wave radar mounting bracket is removed and then refitted.
- The four wheels are aligned.
- The front bumper is hit or deformed.

Contact an authorized FAW Hongqi dealer.



## WARNING

- **When vehicles in the adjacent lane move in front of the direction of travel of this vehicle, if they do not enter the monitoring area, they could not be detected, thus resulting in a response lag of SACC. The driver should pay close attention to movements of vehicles in the adjacent lane and take the initiative to intervene when necessary.**
- **If the vehicle ahead brakes suddenly (for emergency stop), the SACC may be unable to react or react too slowly, thus resulting in a risk of delayed braking. In this case, the driver may not receive a takeover request. The driver should keep focused, and take the initiative to intervene when necessary.**
- **When this vehicle follows the target vehicle and stops in SACC mode, it may start suddenly due to the blocked target vehicle, pedestrians passing by, etc. The driver should keep focused, and take the initiative to intervene when necessary.**



## CAUTION

- **The SACC will control this vehicle at the set following distance from the target vehicle. If the target vehicle decelerates or stops, the SACC will control this vehicle to decelerate or stop automatically.**
- **When the target vehicle restarts or leaves the lane after stopping for no more than 3 seconds, this vehicle will start automatically under the control of SACC.**
- **When the target vehicle restarts or leaves the lane after stopping for more than 3 seconds but no more than 10 minutes, a message to resume cruise control will be shown on the instrument cluster multi-function display of this vehicle, and the driver can resume the SACC by gently depressing the accelerator pedal or pressing left side  $+^2$  button on the steering wheel, thus realizing automatic starting. At this time, the driver should pay attention to the front traffic conditions, so as to determine whether the vehicle can be safely started.**

 **CAUTION**

- **When this vehicle stops for more than 10 minutes, the SACC will be automatically deactivated.**
- **The SACC cannot keep the vehicle braked for a long time. Do not leave the vehicle when the SACC keeps the vehicle stopped. Before leaving the vehicle, be sure to engage the P gear.**
- **During driving through a curve with SACC, pay attention to the followings:**
  - In sharp curves, the SACC may be deactivated or limit the speed.
  - On curves, the SACC may respond to vehicles in another lane, have no time to respond to vehicles in the same lane, make the vehicle collide with the front, or lose control of the vehicle; especially during driving on ramps, the SACC may lose its target due to large curve, thus causing acceleration. On curves, the driver must take extra care and always be ready for braking when necessary. During driving on curves, choose a proper speed.
  - In a curve, too small road radius may affect the judgment of SACC on the lane markings. Drive with caution on curves.
- **When this vehicle passes through an intersection with traffic lights while following the vehicle ahead, the driver should pay attention to the change of traffic lights and actively intervene with the vehicle when necessary to avoid violating traffic rules.**
- **When this vehicle is in dense fog, rain, snow and other weather, or when there are frost and dirt marks on the ADAS camera lens, or when this vehicle is driving towards the sun (or strong light source), a message "IFC is blocked, please clean the windshield" may be displayed on the instrument cluster due to "Limited field of view" of camera, and the SACC cannot work at this time.**



# Tire pressure monitoring system (TPMS)

The TPMS can monitor and check the tire pressure, and automatically issue an alarm when the tire pressure is lower than the limit.

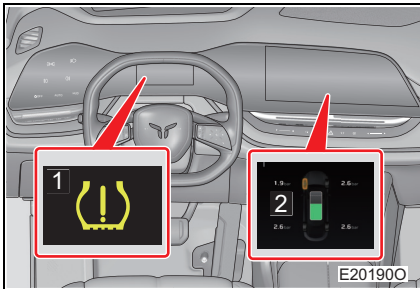

- 1 Tire pressure abnormal/ system fault warning lamp
- 2 Tire pressure information (see P.182)

## Operating condition of system

Vehicle status	Alarm
Tire pressure is abnormal	The system fault warning lamp makes an alarm
The TPMS is not working	The system fault warning lamp comes on, and accompanied by a text indication that the TPMS is invalid

### ■ Tire pressure sensor matching

After wheel replacement or tire rotation, it is necessary to configure the TPMS. Please contact an authorized FAW Hongqi dealer.



## **WARNING**

### **■ Precautions for TPMS**

- This system cannot prevent tire deflation and bursting. It is mainly used to give an alarm when it monitors that the tire pressure is lower than a set value.
- In winter, the tire pressure should be adjusted in time. Because the atmospheric temperature drops in winter, the tire pressure may decrease or fall below the alarm value. When the tire pressure decreases below the alarm value, an alarm will be issued.

### **■ Situation in which TPMS cannot work properly**

This system can make judgments based on subtle changes in tires. However, it sometimes cannot work properly under the following conditions.

- Emergency tires, snow tires and tire chains are used.
- When replacing wheel, do not install the original sensor to the corresponding wheel.

## Lane keeping assist (LDW/LKA)\*

The LDW/LKA can detect the driver's status and the vehicle's driving status when the vehicle speed is 60 - 120 km/h. When the LDW/LKA judges that the driver's subjective intention (such as steering, changing lane etc.) or the driver's non-subjective intention (such as chatting, distraction, operating in-vehicle infotainment system, etc.) causes the vehicle to deviate from its lane, it will give a warning or alarm and correction prompt to prevent danger and traffic violation.

### ■ Lane departure warning (LDW)

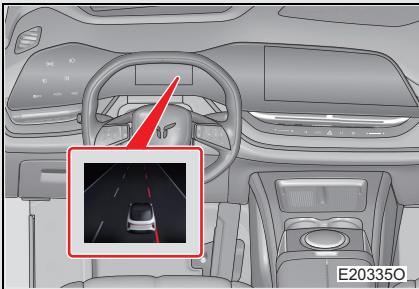

When the system determines that the vehicle is departing from the lane, the line on the corresponding side turns red, and a warning sound is issued at the same time.

### ■ Lane keeping assist (LKA)

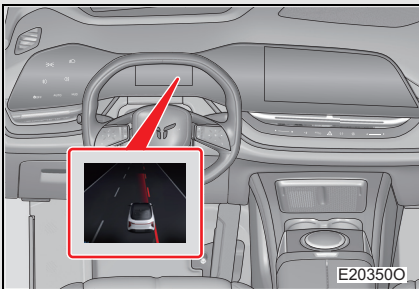

When the system determines that the vehicle is departing from the lane, the line on the corresponding side turns red, and at the same time, a warning sound is issued and the steering wheel also corrects the vehicle's position automatically.

### ■ LDW/LKA settings

The LDW/LKA can be turned on/off through the driver assistance settings interface of the in-vehicle infotainment system. After the system is turned on, the alarm mode can be selected as alarm only or alarm + correction and the LDW sensitivity can be set at the same time. (See P.190)

---

### ■ Operating conditions of LDW/LKA:

- At least one lane marking on either side must be clear and have a length of  $\geq 20$  m.
- The distance between the lane markings on both sides of the road must be  $\geq 3$  m.
- The vehicle speed is  $\geq 60$  km/h and  $\leq 120$  km/h.
- The wipers are not set to the high-speed mode.
- The curve radius is  $\geq 250$  m.
- Other lateral control (SACC, ESA) functions are not activated.
- ABS, ESC functions are not activated.

### ■ The system will suppress the alarm and correction even if the vehicle departs from the lane under the following conditions:

- The driver turns the steering wheel to pass a bend.
- The driver depresses the brake pedal.
- The driver depresses the accelerator pedal deeply.
- The turn signal lamp switch is turned on or returned within 3 seconds.

### ■ The LDW/LKA may not work properly under the following conditions:

- Cameras are blocked by snow, ice, dust or stains on the front windshield.
- The weather causes low visibility, such as heavy fog, heavy rain, heavy snow, etc.
- The road is covered by vehicles or other obstacles.
- The road has a narrow width or the bend curvature is too large.
- The line of sight of the system cameras is blocked.
- When driving towards strong light.
- In complex lane marking conditions, such as diverging/merging, construction area, etc.
- Misrecognition may be caused when there are bridge cables or tree shadows on the road surface.
- When the light is dim or the lane markings are blurred at night.
- The vehicle speed is less than 60 km/h.
- The lane markings do not meet the requirements of national standards.
- The brightness of the external environment of the vehicle suddenly changes, for example, entering a tunnel.

### ■ When the ADAS camera unit or front windshield is replaced or when the four-wheel alignment is performed, the system needs to be recalibrated, otherwise it will not work normally. Contact an authorized FAW Hongqi dealer.

 **WARNING**

- The LDW/LKA is only a driver assistance system. Do not rely on it too much. The driver must drive carefully.
- The driver is the primary controller of the vehicle, whose control on the vehicle takes precedence over the LDW/LKA. The driver must always have control on the vehicle and take full responsibility for the vehicle.
- Stop using the system when road and environmental factors may cause the system not to work properly.
- To prevent disturbance to the driver, the system will not give an alarm when the activation conditions of the LDW/LKA are not met.
- Incorrect calibration of the LDW/LKA may result in misrecognition of other lanes, and even cause accidents.
- The LDW/LKA can recognize lane markings and curbs with certain contrast. However, it may not recognize lane markings and curbs accurately or even fail to do so if they are blurred or stained, and may make false recognition of some wheel traces, watermarks or shadows exhibiting significant color differences and contrast on the road.

## Driver status monitor (DSM)\*

**DSM primarily assesses the current state of the driver through comprehensive vehicle-related information, it can also combines with DSM camera to further evaluate the current driver's facial expressions. When signs of driver fatigue or inattention are detected, it will give timely alarm to reduce the risk of road traffic accidents.**

### ■ Distraction alarm

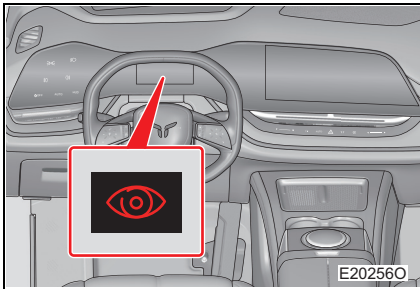

When the system determines that the driver has a distracted intention, the red indicator lamp on the instrument cluster comes on, and sound and text reminders will be given at the same time.

### ■ Fatigue alarm

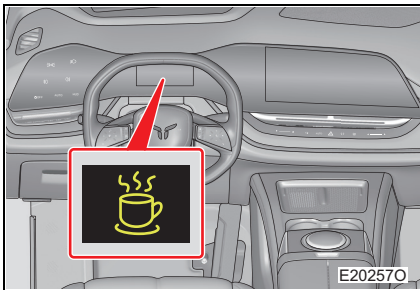

When the system determines that the driver may be in a relatively light abnormal driving status at present, the instrument cluster will give sound and text reminders at the same time.

When the system determines that the driver may be in a serious abnormal driving status at present, the yellow indicator lamp on the instrument cluster flashes, and sound and text reminders will be given at the same time.

## Turning on/off DSM

The DSM can be turned on and off through the driver assistance settings interface of the in-vehicle infotainment system. (See P.189)

### ■ Operating conditions of DSM

DSM is activated when all of the following conditions are met:

- DSM is set to ON in the in-vehicle infotainment system;
- Sit in the driver seat correctly;
- Shift lever is in D;
- The vehicle speed is not lower than 10 km/h;
- DSM related systems have no fault.

### ■ The system will not give an alarm even if DSM is turned on under the following conditions:

- The eyeglass frame can easily block the sight, resulting in unrecognizable eye information and function may be limited at this time.
- The vehicle speed is not higher than 8 km/h.
- The head deviates from the camera area and no facial features of the driver are detected.
- When the vehicle encounters a curve, the steering wheel angle exceeds 12°.

### ■ DSM has limited functionality under the following special working conditions:

- When strong light shines on the driver's glasses, the lens reflects onto the infrared area of the camera, causing the loss of eye coordinates and limiting the DSM function.
- When the camera is obstructed, the instrument cluster prompts a camera fault message. This situation is not a system fault, and if the obstruction is removed in short time, the system will restore its function.
- During the current driving cycle, if DSM turns off automatically due to other related systems, when other system faults are repaired, DSM will turn on automatically.



**WARNING**

- **The DSM is only a driver assistance system. It can only give warnings for the abnormal driving status of the driver, but cannot directly interfere with the vehicle. The driver must consider the warnings and control the steering wheel by himself/herself to ensure the normal driving of the vehicle.**
- **Due to road and environmental factors, the DSM may not normally judge the driver's abnormal driving status. The driver must abide by traffic regulations, stop and rest in time according to own conditions to ensure driving safety.**
- **If the DSM is not calibrated correctly, it may cause misjudgment and even cause accidents.**



## Forward collision warning (FCW) \*

The system automatically judges the collision risk level through the relative distance, relative speed and relative acceleration between the vehicle and the target vehicle. If the conditions are met, the system will give an alarm.

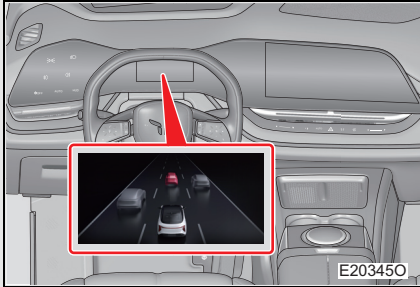

When the system judges that collision may occur, the instrument cluster displays alarm information and issues an audible alarm.

For the target vehicle, when the collision risk level goes up, the system will provide a braking reminder similar to the snub braking effect.

### ■ Turning on/off FCW

The FCW can be turned on and off through the driver assistance settings interface of the in-vehicle infotainment system. It is turned on by default. (See P.189)

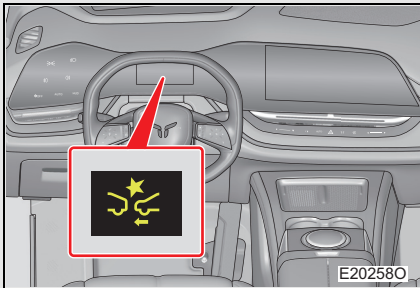

When the system is turned off, the instrument cluster will display the FCW OFF indicator lamp.

### ■ Adjusting or calibrating FCW

Adjust or calibrate the FCW under the following conditions, otherwise the FCW may not work properly:

- The front windshield is damaged or replaced.
- The ADAS camera unit or radar mounting bracket is removed and then refitted.
- The four wheels are aligned.
- The front bumper is hit or deformed.

Contact an authorized FAW Hongqi dealer.



### **WARNING**

- **To ensure driving safety, occupants in the vehicle must fasten their seat belts!**
- **The FCW is only a driver assistance system. Do not rely on the FCW too much. The driver must drive carefully.**
- **The FCW only gives an early warning of collision danger. The driver must control the brake pedal or steering wheel to prevent collision.**
- **The FCW may not recognize modified or decorated vehicles with special appearance.**
- **As the FCW obtains information by recognizing the rear of other vehicles, it will not give an alarm for oncoming vehicles and front crossing vehicles.**
- **In complex traffic conditions, the FCW may experience delays in recognizing vehicles, leading to delayed alarms.**
- **On curved roads, hill roads or extremely bumpy roads, the system may not detect the vehicles ahead. The driver must drive carefully.**
- **The FCW system is a warning system. It cannot detect other vehicles in all cases. For example, the rear of a vehicle is seriously blocked, the shape of a vehicle is unusual (e.g., an overloaded vehicle carrying trees), the rear of a vehicle is seriously damaged, etc.**
- **The FCW may not recognize narrow objects such as pedestrian or bicycle.**
- **When rain, snow, ice, fog or dust blocks the sensors, the performance of system may degrade or fail. The driver must drive carefully.**
- **The front windshield shall not be modified or covered by any auxiliary equipment. Otherwise, the FCW may degrade or fail.**

 **WARNING**

- If cameras are displaced due to collision, the FCW may degrade or fail. Please calibrate the FCW by driver in time.
- Never use an FCW that is incorrectly calibrated.
- For scenes like strong backlighting, road reflection, insufficient ambient lighting, etc., the FCW may not work normally. The driver must drive carefully.
- If the chassis of the preceding vehicle is high, or the goods protrude from the rear of the preceding vehicle, please pay attention to the danger that may occur.
- The FCW may not recognize targets such as cyclist.
- The front bumper must not be painted, modified or blocked by any auxiliary equipment. Otherwise, the performance of forward millimeter wave radar sensors may degrade or fail!
- Severe extreme weather conditions such as heavy snow, rain, ice and fog may lead to the performance degradation or failure of forward millimeter wave radar sensors. In such weather conditions, the driver must use the FCW carefully.
- If the forward millimeter wave radar sensors are displaced due to collision, the FCW may degrade or fail. The driver shall calibrate the forward millimeter wave radar sensors in time.
- Do not use forward millimeter wave radar sensors that are incorrectly calibrated.

 **CAUTION**

- In order to avoid disturbing the driver by false alarms, no alarms will be given under the following conditions:
  - The front windshield is damaged or replaced.
  - The vehicle speed is less than 8 km/h.
  - The previous alarm is issued not more than 3 seconds.
  - The driver turns the steering wheel too fast or by a large angle.
  - The driver slams on the accelerator pedal, causing a large pedal position.

## Autonomous emergency braking (AEB)\*

The working range of the AEB is 8 km/h ~ 80 km/h.

When the vehicle may collide with the preceding vehicle in case of emergency, if the driver fails to perform emergency braking or emergency steering to avoid danger in time, the system will assist the driver in applying brake to avoid or reduce the collision injury.

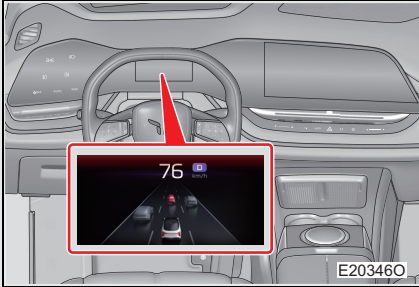

When the AEB works, the instrument cluster displays alarm information and an audible alarm is issued.

### ■ Turning on/off AEB

The AEB can be turned on and off through the driver assistance settings interface of the in-vehicle infotainment system. (See P.189)

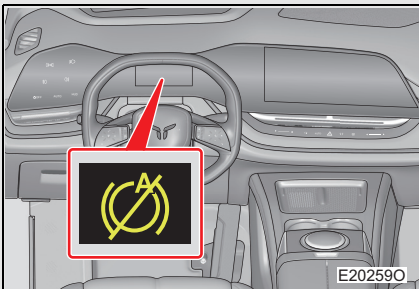

When the system is turned off, the instrument cluster will display the AEB OFF indicator lamp.

### ■ Adjusting or calibrating AEB

Adjust or calibrate the AEB under the following conditions, otherwise the AEB may not work properly:

- The front windshield is damaged or replaced.
- The ADAS camera unit or radar mounting bracket is removed and then refitted.
- The four wheels are aligned.
- The front bumper is hit or deformed.

Contact an authorized FAW Hongqi dealer.



### WARNING

- To ensure driving safety, occupants in the vehicle must fasten their seat belts.
- The AEB is only a driver assistance system. Do not rely on the AEB too much. The driver must drive carefully.
- The AEB may not be able to recognize modified or decorated vehicles with special appearance.
- On curved roads, hill roads or extremely bumpy roads, the system may not detect the vehicles ahead. The driver must drive carefully.
- The AEB may not recognize targets such as cyclist.
- The braking function of the AEB system will not be activated when the ESC is off or faulty.
- If there is heavy snow or rain, the system may not work properly.
- For scenes like strong backlighting, road reflection, insufficient ambient lighting, etc., the AEB may not work normally. The driver must drive carefully.
- If the vehicle is towing another vehicle or a trailer, turn off the AEB. When brakes are controlled under towing conditions, the safety of the vehicle deteriorates.
- If the chassis of the preceding vehicle is high, or the goods protrude from the rear of the preceding vehicle, please pay attention to the danger that may occur.
- The front windshield shall not be modified or covered by any auxiliary equipment. Otherwise, the performance of AEB may degrade or fail.
- If cameras are displaced due to collision, the AEB may degrade or fail. Please calibrate the AEB by driver in time.

 **WARNING**

- **Never use an AEB that is incorrectly calibrated.**
- **As the AEB obtains information by recognizing the rear of other vehicles, it will not give an alarm for oncoming vehicles and front crossing vehicles.**
- **The AEB is an auxiliary system. It cannot detect other vehicles in all cases. For example, the rear of a vehicle is seriously blocked, the shape of a vehicle is unusual (e.g., an overloaded vehicle carrying trees), the rear of a vehicle is seriously damaged, etc.**
- **When the vehicle is driving in a curve, the AEB may not be able to accurately judge the state of stationary objects in the driving direction, so the system may not carry out autonomous emergency braking assistance.**
- **The AEB does not always help the driver in all environments. Therefore, the driver shall not rely on the system completely, and must concentrate on observing road conditions to ensure driving safety.**
- **The AEB is an active auxiliary safety system. However, it cannot completely guarantee collision avoidance with vehicles in front under any conditions. The driver is responsible for driving and avoiding dangerous conditions. In case of emergency, the driver should brake as soon as possible.**
- **If the AEB is activated, the driver should promptly take control of the vehicle after it comes to a stop to prevent unintended restarting, which may lead to the vehicle slipping.**
- **The front bumper must not be painted, modified or blocked by any auxiliary equipment. Otherwise, the performance of forward millimeter wave radar sensors may degrade or fail!**
- **Severe extreme weather conditions such as heavy snow, rain, ice and fog may lead to the performance degradation or failure of forward millimeter wave radar sensors. In such weather, the driver must use the AEB carefully.**
- **If the forward millimeter wave radar sensors are displaced due to collision, the AEB may degrade or fail. The driver shall calibrate the forward millimeter wave radar sensors in time.**
- **Do not use forward millimeter wave radar sensors that are incorrectly calibrated.**

 **CAUTION**

- **In order to avoid disturbing the driver by false alarms, no alarms will be given under the following conditions:**
  - The vehicle speed is less than 8 km/h.
  - The previous alarm is issued not more than 20 seconds.
- **When the AEB works, it will be deactivated if any of the following conditions are met:**
  - The driver turns the steering wheel too fast or by a large angle.
  - The driver slams on the accelerator pedal, causing a large pedal position.
  - The speed reduction exceeds the threshold of 60 km/h.
- **When any of the following conditions are met, the AEB will not be triggered, allowing the driver to maintain control of the vehicle without unnecessary interference:**
  - ESC/TCS/ABS function is activated.
  - The R gear is engaged.
  - Any door is not closed.
  - The front compartment cover is not closed.
  - The driver unfastens the seat belt.
  - The automatic parking function is turned on.
  - The previous alarm is issued not more than 20 seconds.
  - The vehicle speed is less than about 8 km/h.
  - The driver turns the steering wheel too fast or by a large angle.
  - The driver slams on the accelerator pedal, causing a large pedal position.

## 6-4. Using driver assistance system

# Blind spot detection (BSD)\*

The system has the functions of blind spot detection, lane change assistance, rear cross traffic alert, front cross traffic alert and rear collision warning to assist the driver in driving.

### Blind spot detection and lane change assistance

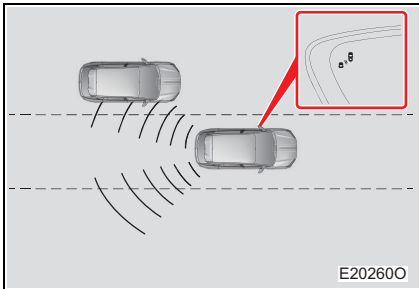

When the shift lever is set to D gear and the vehicle speed is higher than 15 km/h, if a rear side vehicle within the blind spot of 5 m behind the vehicle or within the range of 5~70 m poses a collision risk, the warning indicator lamp on the exterior rearview mirror of the corresponding side comes on and the instrument cluster displays a warning message. If the turn signal lamp switch on the corresponding side is turned on at this time, the warning indicator lamp flashes and a warning sound is issued at the same time, prompting the driver that there is danger in changing lanes. The function is turned off when the vehicle speed is less than 12 km/h.



## Rear cross traffic alert

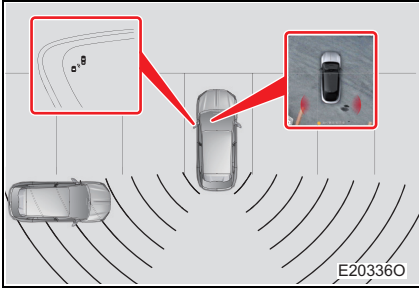

When the shift lever is set to R gear and the vehicle speed is 0~15 km/h, if there are crossing vehicles, electric bicycles, bicycles and other targets in the lateral direction behind the vehicle, the system will determine whether there is a collision risk and the level of collision risk for the relevant targets. If there is a risk, the exterior rearview mirror warning indicator lamp on corresponding side will come on, and the in-vehicle infotainment system display will display an alarm message to avoid collision.

## Front cross traffic alert

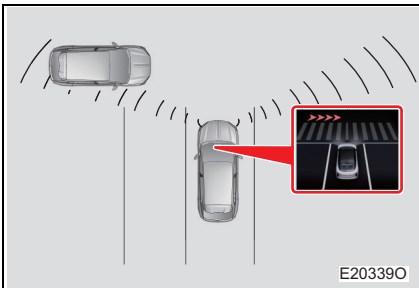

When the shift lever is set to D or N gear and the vehicle speed is between 1~6 km/h, if there are crossing vehicles, electric bicycles, bicycles and other targets in the lateral direction in front of the vehicle and the target speed is  $\geq 10$  km/h, the system will determine whether there is a collision risk and the level of collision risk for the relevant targets. If there is a risk, an alarm will be given through the instrument cluster display screen and sound to avoid collision.

## Rear collision warning

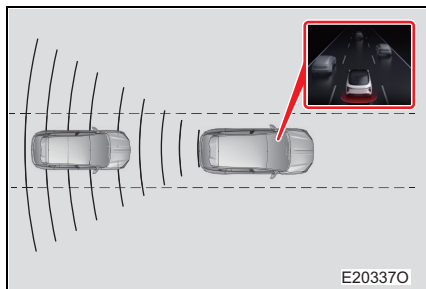

When the shift lever is not set to R position, if a rear vehicle is within 80 m from this vehicle, system will monitor the driving status of the following vehicle to judge the possibility of rear-end collision. When there is a danger, the instrument cluster displays a warning message and triggers the hazard warning lamp to flash to remind the driver and the following vehicle that there is a risk of collision

## Turning on/off BSD

Each function of the BSD can be turned on and off through the driver assistance settings interface of the in-vehicle infotainment system. (See P.190)

- **The BSD and lane change assistance may not give an alarm or may give a delayed alarm under the following conditions:**
  - The vehicle is driving on a steep slope.
  - The vehicle is navigating the mountain top or a hill road.
  - There is a height difference between the driving lane and the adjacent lane.
  - The turning radius is small.
  - The vehicle is driving on snow-covered roads for a long time.
  - A large amount of snow or ice gathers near radar sensors.
- **The BSD and lane change assistance may advance the alarm or expand the alarm range under the following conditions**
  - If two lanes are too narrow, an alarm will occur in the adjacent lane.
  - The vehicle drives on roads with fixed obstacles near the side of the vehicle for a long time (e.g., tunnel wall, cement barrier of viaduct, metal billboard, etc.).
- **The rear cross traffic alert may not give an alarm or may expand the alarm range under the following conditions:**
  - The vehicle is parked at an oblique angle.
  - The reverse speed exceeds 15 km/h.

- A large amount of snow or ice gathers near radar sensors.
- The speed and yaw angle of the target vehicle are constantly changing in the detection area.
- Another vehicle directly approaches this vehicle from the rear.
- **The front cross traffic alert may not give an alarm or may expand the alarm range under the following conditions:**
  - A large amount of snow or ice gathers near radar sensors.
  - The speed and yaw angle of the target vehicle are constantly changing in the detection area.
- **The rear collision warning may not give an alarm or may expand the alarm range under the following conditions:**
  - A large amount of snow or ice gathers near radar sensors.
  - The speed and yaw angle of the target vehicle are constantly changing in the detection area.
  - To ensure maximum safety, an alarm may also be given in some low-speed target scenes.

 **CAUTION**

- **Be careful not to impact the bumper during parking. Otherwise, the sensors in the bumper may be displaced or damaged, which may cause the system to shut down automatically or affect the system function.**
- **In order to ensure the normal operation of the system, the sensors in the bumper must be kept clean and not be covered by other objects.**
- **Only the paint approved by our company can be applied to the bumper. Other types of paint may cause limited functions or failure of the BSD.**
- **If the BSD does not work normally, turn it off immediately, and contact an authorized FAW Hongqi dealer for repair.**
- **After the BSD is repaired, it needs to be calibrated. For details, please contact an authorized FAW Hongqi dealer.**
- **The BSD is only an auxiliary reminder, and cannot completely avoid vehicle collision in blind spots. Before changing lanes, please check the rearview mirrors, give a glance to rear areas and use the turn signal lamps.**
- **Under special working conditions such as wet weather and high vehicle speed, the BSD may give false alarms or miss alarms, which are normal phenomena.**
- **When the rear BSD radar is blocked, the BSD will not work. Therefore, it needs to be cleaned in time.**
- **As the BSD is limited by physical laws and working conditions, it may not correctly recognize traffic conditions under some driving conditions. For example:**
  - In a sharp turn lane.
  - In a lane with varying width.
  - On a bumpy road in the mountain.
  - In bad weather.
  - Near some special buildings on the roadside, such as high or scattered highway guardrail.

 **WARNING**

- **The BSD is only a driver assistance system. Do not rely on it too much. The driver must drive carefully.**
- **The driver is the primary controller of the vehicle. The BSD is only an auxiliary reminder. The driver must always have control on the vehicle and take full responsibility for the vehicle.**
- **Turn off the radar detection system when towing the vehicle or some accessories (e.g., bicycle carrier) are installed at the rear of vehicle. Otherwise, the radio waves emitted by the radar may be blocked, resulting in abnormal operation of the system.**
- **The BSD can detect targets such as vehicle, electric bicycle and bicycle etc. If target vehicles have characteristics such as irregular shape, modification, painted surface, etc., the recognition effect cannot be guaranteed. The recognition of pedestrians, animals or other objects cannot be guaranteed too. In such cases, the driver must drive carefully.**
- **The BSD utilizes intelligent technologies that adhere to the laws of physics, and it operates within specific system limitations. Therefore, the driver should concentrate on observing road and traffic conditions to prevent accidents.**
  - Be sure to adjust the vehicle speed and maintain the safe distance from the vehicle ahead based on current visibility, weather conditions, road and traffic conditions.
  - Always hold the steering wheel with both hands while driving, and be ready to turn it at any time.
  - Pay attention to the indicator lamps on exterior rearview mirrors and the information displayed on the multifunction display screen of the instrument cluster, and take appropriate actions in response to the indications.
  - The BSD may react to specific roadside structures (e.g., high or skewed guardrail) and thus give false alarms.
  - Always pay attention to the road conditions and surrounding conditions of the vehicle.
  - Do not use the BSD when the sensors are dirty or damaged, as this may impact the functions of the BSD.

 **WARNING**

- When the sun shines directly, the field of view of exterior rearview mirrors may be limited.
- During driving, be sure to strictly follow the instructions provided by warning lamps/indicator lamps and related text information. Otherwise, accidents are prone to occurring and serious personal injuries will be caused.

# Emergency steering assistance (ESA)\*

When the vehicle speed is 50~120 km/h and the sensor detects the potential collision risk, ESA will assist the driver to steer and avoid the collision when the driver is detected to steer and understeer. Avoidance targets include motor vehicles, motorcycles, bicycles, pedestrians, construction areas, obstacles, etc.

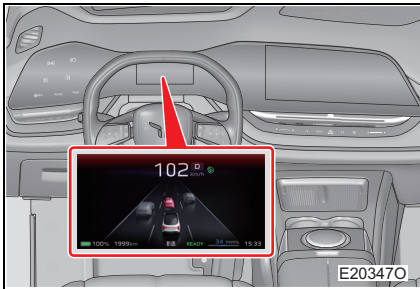

When the ESA function works, the instrument cluster displays warning information

### Turning on/off ESA function

The ESA function can be turned on and off through the driver assistance settings interface of the in-vehicle infotainment system. (See P.189)

#### ■ Operating conditions of ESA

ESA is activated when all of the following conditions are met:

- ESA is set to ON in the in-vehicle infotainment system.
- Shift lever is in D.
- The vehicle speed is 50 ~ 120 km/h.
- ESA related systems have no fault.

#### ■ Adjusting or calibrating ESA

Adjust or calibrate the ESA under the following conditions, otherwise the ESA may not work properly:

- The front windshield is damaged or replaced.
- The ADAS camera unit or radar mounting bracket is removed and then refitted.
- The four wheels are aligned.
- The front bumper is hit or deformed.

Contact an authorized FAW Hongqi dealer.

 **WARNING**

- **The driver is the primary controller of the vehicle, whose control on the vehicle takes precedence over the ESA. The driver must always have control on the vehicle and take full responsibility for the vehicle.**
- **The ESA is only a driver assistance system. Do not rely on the ESA too much. The driver must drive carefully.**
- **The ESA may not recognize modified or decorated vehicles with special appearance.**
- **In complex traffic conditions, the ESA may experience delays in recognizing vehicles, leading to delayed alarms.**
- **On curved roads, hill roads or extremely bumpy roads, the system may not detect the vehicles ahead. The driver must drive carefully.**
- **The ESA is a driver assistance system. It cannot detect other vehicles in all cases. For example, the rear of a vehicle is seriously blocked, the shape of a vehicle is unusual (e.g., an overloaded vehicle carrying trees), the rear of a vehicle is seriously damaged, etc.**
- **For scenes like strong backlighting, road reflection, insufficient ambient lighting, etc., the ESA may not work normally. The driver must drive carefully.**
- **If the chassis of the preceding vehicle is high, or the goods protrude from the rear of the preceding vehicle, please pay attention to the danger that may occur.**
- **The front windshield shall not be modified or covered by any auxiliary equipment. Otherwise, the ESA may not work properly.**
- **The front bumper must not be painted, modified or covered by any auxiliary equipment. Otherwise, the performance of forward millimeter wave radar sensors may degrade or fail.**
- **Severe extreme weather conditions such as heavy snow, rain, ice and fog may lead to the performance degradation or failure of forward millimeter wave radar sensors. In such weather, the driver must disable the ESA.**
- **If the forward millimeter wave radar sensors are displaced due to collision, the ESA may degrade or fail. The driver shall calibrate the forward millimeter wave radar sensors in time.**
- **Do not use forward millimeter wave radar sensors that are incorrectly calibrated.**



 **CAUTION**

- When the driver depresses the accelerator pedal deeply, ESA is not activated for safety reasons.
- When this vehicle is in dense fog, rain, snow and other weather conditions, or when there are frost and dirt marks on the ADAS camera lens, or when this vehicle is driving towards the sun (or strong light source), a message "ADAS camera is blocked, please clean the windshield" may be displayed on the instrument cluster due to "Limited field of view" of camera, and the ESA cannot work at this time.

## Intelligent speed limit warning system (ISA)\*

ISA can accurately recognize the speed limit sign and speed limit release sign ahead during the driving. ISA includes speed limit information display and speed limit warning functions, which remind drivers when the vehicle exceeds the speed limit to ensure driving safety.

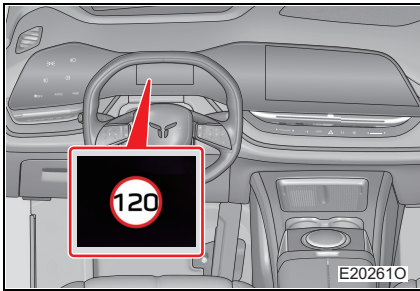

When the system recognizes a speed limit sign, if the vehicle speed is less than the speed limit value, the instrument cluster will only display the current speed limit requirement through the indicator lamp; and if the vehicle speed is more than the speed limit value, the instrument cluster will remind the driver of overspeed through sound/icon.

### Enabling/disabling intelligent speed limit warning system (ISA)

The ISA can be enabled and disabled through the vehicle settings interface of the in-vehicle infotainment system. (See P.189)

#### ■ Overspeed alarm mode setting:

- Off: Only display the current road speed limit information, when vehicle speed exceeds the speed limit value, there are no speed limit icon flashing prompt and sound alarm.
- Only visual: When vehicle speed exceeds the speed limit value, there is only speed limit icon flashing prompt without sound alarm.
- Visual + sound: When vehicle speed exceeds the speed limit value, there are speed limit icon flashing prompt and sound alarm.

#### ■ Adjusting or calibrating ISA

Adjust or calibrate the ISA under the following conditions, otherwise the ISA may not work properly:

- The front windshield is damaged or replaced.
- The four wheels are aligned.
- The ADAS camera unit is replaced.

For calibration, contact an authorized FAW Hongqi dealer.

**WARNING**

- **ISA is only a driver assistance system. Do not rely on the ISA too much. The driver must drive carefully.**
- **The driver is the primary controller of the vehicle, and must always have control on the vehicle and take full responsibility for the vehicle.**
- **If there is heavy snow or rain, ISA may not work properly (it may give false alarms or miss alarms).**
- **For scenes like strong backlighting, road reflection, insufficient ambient lighting, etc., the ISA may not work properly (it may give false alarms or miss alarms). The driver must drive carefully.**
- **The front windshield shall not be modified or covered by any auxiliary equipment. Otherwise, the performance of ISA may degrade or fail (it may give false alarms or miss alarms).**
- **If cameras are displaced due to collision, the ISA may degrade or fail. Please calibrate the ISA by driver in time.**
- **When the sign is not in a specified style or placed at a position that conforms to regulations, ISA will fail to recognize it properly (it may give false alarms or miss alarms).**
- **The actual speed limit in certain circumstances should not be affected by the instructions and warnings for the functions of ISA system, and the driver is still ultimately responsible for adhering to speed limit. As specified in Article 3.4.2.4 of Regulation (EU) 2021/1958.**

## 6-4. Using driver assistance system

# Driver controlled lane change (DCLC)\*

DCLC function refers to the system receiving a lane change instruction from the driver, the vehicle sensor detects the surrounding environment to search for lane change space in adjacent lane, calculates the lane change trajectory, and controls the vehicle to change to the target lane safely. This function presupposes the activation of SACC. After the driver moves the turn signal lamp control lever, automatic lane change control will be performed when system determines that the lane changing conditions are met. If the system detects that the adjacent road conditions are not met, it will suppress lane change to ensure safety.

The DCLC function is suitable for use on highways with clear lane markings and a divider separating opposing traffic. Do not use it on urban roads.

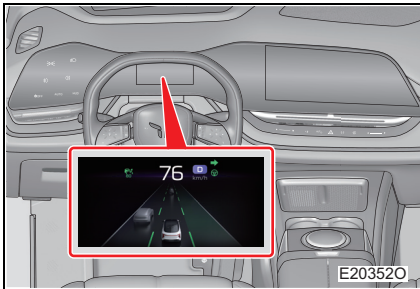

When SACC is activated and the vehicle speed is 45-120 km/h, the driver moves the turn signal lamp control lever to the left or right to the locked position. When the vehicle determines that the lane change conditions are met, it automatically changes to the left or right lane. During the lane change process, the instrument cluster displays the target position of the vehicle on the target lane.

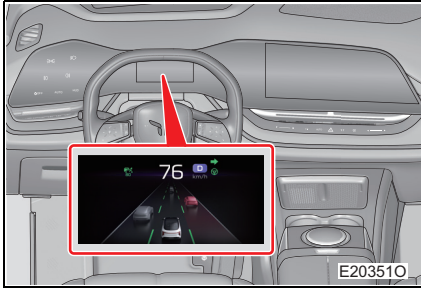

During the lane change process, when the driver moves back the turn signal lamp control lever or the target lane does not support lane change, if the vehicle does not change to the target lane, the vehicle will return to its original lane. Once returned, the vehicle should be centered in the original lane and return to SACC state.

### Turning on/off DCLC function

The DCLC function of SACC can be turned on and off through the driver assistance settings interface of the in-vehicle infotainment system. (See P.189)

#### ■ Setting conditions of DCLC:

- SACC is in a normal activation state
- Turn signal lamp has no fault
- Radar has no fault
- This vehicle is at a safe distance from vehicle ahead
- This vehicle is at a safe distance from vehicle ahead in the target lane
- This vehicle is at a safe distance from vehicle behind in the target lane
- The vehicle speed is 60 - 120 km/h
- Adjacent lane markings are white dashed lines
- The driver operates the turn signal lamp control lever

#### ■ Canceling conditions of DCLC:

- SACC is canceled
- Turn signal lamp fault
- Radar fault
- Insufficient distance between this vehicle and vehicle ahead
- Insufficient distance between this vehicle and vehicle ahead in the target lane
- Insufficient distance between this vehicle and vehicle behind in the target lane
- The vehicle speed is lower than 60 km/h or higher than 120 km/h

- Adjacent lane markings are not white dashed lines
- The driver moves back the turn signal lamp control lever
- The driver depresses the accelerator pedal or turns the steering wheel

### ■ **Adjusting or calibrating DCLC**

Adjust or calibrate the DCLC under the following conditions, otherwise the DCLC may not work properly:

- The front windshield is damaged or replaced.
- The ADAS camera unit or millimeter wave radar mounting bracket is removed and then refitted.
- The four wheels are aligned.
- The front, rear bumpers are hit or deformed.

Contact an authorized FAW Hongqi dealer.

**WARNING**
**■ Preventing accidental activation of DCLC function**

- When this function is not in use, deactivate DCLC function.

**■ Situations where DCLC should not be used**

To avoid the possibility of losing control of the vehicle and causing serious injury or death, do not use the DCLC under any of the following conditions:

- Traffic jams
  - Complicated road conditions
  - Sharp turns
  - Winding roads
  - Slippery roads (such as roads covered with rain, ice or snow)
  - Steep slopes
  - There is a stationary obstacle in front of the vehicle
  - Weather such as snow, rain, ice and dense fog
  - Poor road lighting at night
  - The lane markings are not clear
  - When the vehicle ahead in this lane, the vehicle ahead in target lane, or the vehicle behind in target lane is driving fiercely
- DCLC function needs to be used on roads that meet the following conditions, otherwise it may cause losing control of vehicle and serious injury or death.**
- Roads with strict entrances and exits
  - There are clear separation facilities to distinguish opposing traffic
  - No three-dimensional or horizontal intersections, no facilities such as traffic lamps, etc
  - No obstacles or potholes
  - No construction occupying-road, no traffic control, no traffic accidents
  - The lane markings are clear and meet relevant national standards
  - Mild weather conditions, no heavy rain, fog, wind, snow and other conditions



**WARNING**

- **The driver is the primary controller of the vehicle, whose control on the vehicle takes precedence over the DCLC function. Even if the vehicle is in DCLC, when the driver depresses the brake pedal or operates the steering wheel, the vehicle will be under the control of the driver. The driver must always keep control of the vehicle and take full responsibility for the vehicle.**
- **When driving on a repaired asphalt road or a road with strong light reflection, the vehicle may deviate from the driving lane. The driver should keep focused, and take the initiative to intervene when necessary.**
- **DCLC is only a driver assistance system. If necessary, the driver should immediately deactivate the DCLC and drive by himself/herself.**
- **When using DCLC, please comply with relevant local laws and regulations, and adapt to the traffic, road and weather conditions at that time.**
- **The front windshield shall not be modified or covered by any auxiliary equipment. Otherwise, the DCLC may not work properly.**



 **WARNING**

- When leaving the driver seat for a long time, be sure to disable the DCLC to avoid accidents caused by misoperation.
- When this vehicle changes the lane, the DCLC may lose the target vehicle or misidentify the target vehicle.
- The DCLC cannot detect other sides than tail of the vehicle, children, pedestrians, animals or other objects or apply the brake for them. At this time, the driver must drive carefully.
- The DCLC has limited braking capacity. It may have no time to slow down to avoid a collision with the vehicle ahead when the vehicle ahead suddenly decelerates, stops or enters your lane. If a danger is felt, please actively depress the brake pedal for braking.
- The driver needs to ensure that the vehicle can be decelerated to a stop within their field of view at all times.
- The DCLC can only recognize motor vehicles (such as vehicles and trucks) with legal license plates that are capable of driving on highways. If vehicle ahead has characteristics of irregular shape, modification, painted surface, etc., the recognition effect cannot be guaranteed. The recognition of pedestrians and narrow vehicles (such as bicycles and motorcycles) cannot be guaranteed either. At this time, the driver should be prepared to take control of the vehicle at any time according to the actual situation.
- The DCLC may not accurately recognize large trailers. At this time, the driver should take over the vehicle at any time according to the actual situation.
- The DCLC cannot accurately determine the passing width of the lane ahead. Therefore, when the front lane is too narrow and the driver feels unable to pass normally, the driver should immediately deactivate the DCLC through braking intervention and control the vehicle.
- Do not use the DCLC on steep slopes. The DCLC may not detect vehicles in the relevant lane, so the driver usually needs to control the acceleration and braking of the vehicle. If the brake is applied, the DCLC will be deactivated.

 **WARNING**

- If a foot is placed on the accelerator pedal, the DCLC may not automatically apply the brake, resulting in a collision with another vehicle, so the driver should keep focused.
- The front and rear bumpers must not be painted, modified or covered by any auxiliary equipment. Otherwise, the performance of millimeter wave radar may degrade or fail!
- Severe extreme weather such as heavy snow, rain, ice and fog may lead to the performance degradation or failure of millimeter wave radar sensors. In such weather, the driver must disable the DCLC.
- If the millimeter wave radar sensors are displaced due to collision, the DCLC function may degrade or fail. The driver shall calibrate the millimeter wave radar sensors in time.
- Do not use millimeter wave radar sensors that are incorrectly calibrated.
- DCLC function may not accurately recognize the position and speed of vehicles ahead in this lane, vehicles ahead and behind in adjacent lanes, resulting in a risk of collision during the lane change process. During driving, the driver always needs to concentrate fully, and should always be ready to take measures and apply steering and braking.
- The vehicle may return to its original lane with DCLC function because the conditions for lane change are not met or the lane change is risky.

## 6-4. Using driver assistance system

# Reverse tracking\*

When the vehicle is in low speed with D gear, the reverse tracking function automatically records the vehicle's forward tracking for the last 60 meters. When the vehicle needs to return in a narrow space, the function can be activated when the vehicle is stopped. The vehicle controls the steering wheel according to the recorded path, and the driver only needs to control the brake pedal and the vehicle automatically reverses to the starting position of recorded path, and the remaining distance is displayed on the AVM interface. The system can only follow the recorded path and cannot correct the route. If a collision occurs when the vehicle is moving forward, a secondary collision may occur when vehicle returns back.

### Usage method of reverse tracking

#### Step 1

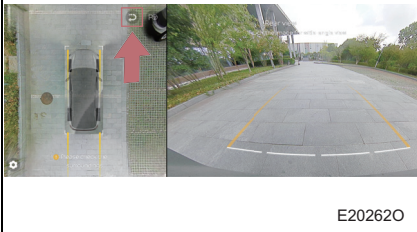

Shift the shift lever to R gear, and enter the AVM interface. Touch [Reverse tracking] button on the AVM interface.

#### Step 2



The driver can release the brake and steering wheel when the system prompts "Please release the brake slowly and release the steering wheel", the vehicle enters reverse tracking. The driver can control the vehicle speed by the brake pedal during tracking.

The remaining distance is displayed on the AVM interface during reversing.

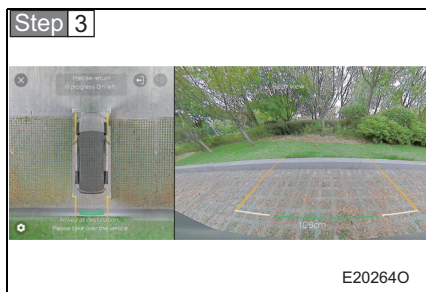

After returning is completed, the system will not control the vehicle, the driver should take over the vehicle in time.

The remaining distance is displayed on the AVM interface during reversing. After the tracking is completed, return to the AVM interface.

### ■ Exit conditions of reverse tracking:

- Tracking system faults (ultrasonic sensor fault, HD camera fault, controller fault, etc.)
- Related system faults (brake system, power system, steering system, gear shift system, etc.)
- Vehicle speed too fast
- The driver clicks the exit button
- When suspend recovery conditions are met and tracking can be continued, the driver does not press the continue tracking button within the specified time
- EPB intervention
- Steering wheel intervention
- Gear intervention

### ■ Limited conditions of reverse tracking:

Operating the reverse tracking system under the following conditions (but not limited to the following conditions) may cause system performance degradation, failure, or security risks:

- Uneven roads, or steep slope
- The route is short or the tracking route space is limited
- Wet or icy road surface
- The camera or ultrasonic sensor is obscured by an object
- Vehicle inclination caused by the vehicle modification, using of non-original size tires, inconsistent tire pressure, inaccurate four-wheel alignment, steering wheel misalignment, etc.
- When the driver reverses manually, the distance from the original path is large

 **WARNING**

- The driver is the primary controller of the vehicle, whose control on the vehicle takes precedence over the reverse tracking function. Even if the vehicle is in reverse tracking mode, when the driver operates the steering wheel, the vehicle will be under the control of the driver. The driver must always keep control of the vehicle and take full responsibility for the vehicle.
- The reverse tracking function can help the driver drive back to the original position in the restricted space, play a certain assistance role, requiring the driver to observe the surrounding environment in real time, and the driver needs to intervene if necessary.
- Please drive carefully and visually confirm the situation around the vehicle when turning on the reverse tracking function. Since the reverse tracking function only memorizes the driving route when driving forward, it cannot predict the unexpected situation where objects suddenly enter the path during reversing, which may lead to accidents or collisions with objects.
- In the process of reverse tracking, although the system may detect obstacles on the path and apply the brake, the driver is still the first responsible person and needs to observe the situation around the vehicle throughout the tracking.
- When an emergency is found and an emergency braking is needed. The driver needs to take control of the vehicle immediately, such as depressing the brake pedal, shifting gears, activating EPB or turning the steering wheel to avoid dangerous situations.
- After the reverse tracking is completed, the driver must pay attention to the gear and speed to avoid accidents.

 **CAUTION**

- **To ensure safe use of reverse tracking, use it in the following scenes:**
  - On a flat road.
  - The road is non-slip.
  - No rain, snow, fog.
  - There are no thin or low obstacles in and around the forward and return paths.
- **It is not recommended to have sharp steering angle or high speed on the path memorized by the reverse tracking, otherwise it will affect the path tracking accuracy.**
- **The reverse tracking function is mainly applied to drive through narrow road, and it is recommended not to use it in corners and parking spaces. APA is recommended in the parking space.**
- **Ultrasonic and AVM prompts only assist the driver in reverse tracking and there are blind spots, so the driver needs to pay attention to the surrounding environment in real time. When the ultrasonic sensor and camera are blocked, it is necessary to clean up in time.**
- **Due to the characteristics of the sensor, road bumps, steps, low obstacles or small obstacles cannot be detected and the detection of obstacles takes a certain period of time, so it may not be able to effectively identify sudden obstacles.**
- **The position of the camera may be moved due to vehicle vibrations and other reasons, it needs to be re-calibrated when the around view image becomes discontinuous and unclear.**
- **Due to factors such as mechanical deviation, tire pressure and road conditions, the control accuracy of the system may be reduced, and the reverse path has a certain deviation, and the original path return can not be fully guaranteed.**

## 6-4. Using driver assistance system

# Driver assistance system

**The related functions integrated in the ESC vary slightly among different vehicle models. To improve the driving safety and performance of the vehicle, the following functions will work automatically based on various driving conditions. However, remember that these functions are only for auxiliary purpose. Do not rely on them too much during driving.**

■ **Antilock brake system (ABS)**

This system can prevent sideslip or pulling to one side of the vehicle due to locked wheels during driving on slippery roads or during emergency braking.

■ **Electronic brakeforce distribution (EBD)**

This system can dynamically distribute brake force proportionally between the front and rear wheels based on the change in vehicle load, road conditions and brake force, so as to improve the braking stability and maneuverability of the vehicle.

■ **Traction control system (TCS)**

This system can prevent the driving wheels from slipping and ensure the acceleration performance when the vehicle starts or accelerates on a slippery road.

■ **Hydraulic brake assist (HBA)**

This system can execute the braking force compensation when the brake pedal is depressed quickly, so as to effectively increase the brake force.

■ **Hill hold control (HHC)**

When the vehicle is started on the slope, for a certain duration after the driver transitions from the brake pedal to the accelerator pedal, this function will properly maintain the brake pressure applied by the driver to prevent the vehicle from slipping.

■ **Hill descent control (HDC)**

When the vehicle is going downhill and the speed is in a certain speed range, apply corresponding brake force to the wheels to maintain a stable speed when driving downhill.

The HDC can be turned on and off through the driving settings interface of in-vehicle infotainment system. (See P.189)

### ■ Electronic stability control (ESC)

This system can help the driver control sideslip during sudden or slippery road turns, so as to ensure the vehicle follows the correct driving track.

### ■ Controlled deceleration for ACC-Stop & Go (CDD-S)

This system can assist the ACC in achieving deceleration control of the vehicle.

### ■ Controlled deceleration for parking brake (CDP)

When P gear button is pressed for a long time, the vehicle actively enters the deceleration state.

### ■ AUTO HOLD

When the vehicle is stationary, the AUTO HOLD applies the parking brake through the hydraulic system and maintains this state for a short time, and then the EPB performs parking.

### ■ Automatic brake prefill (ABP)

According to the request of the relevant control unit, the ESC actively pre-pressurizes the braking system to improve the response speed to braking.

### ■ Brake boost function (BBF)

By monitoring the brake pedal travel depressed by the driver, the vehicle provides stable brake assistance according to the driver's braking intention.

### ■ Comfort stop (CST)

The vehicle avoids pitching when braking is applied, thereby increasing the smoothness and comfort of the stop.

The CST can be turned on and off through the driving settings interface of the in-vehicle infotainment system. (See P.188)

### **Electric power steering (EPS)**

This system can use a motor to reduce the force required for turning the steering wheel.



## When TCS/ESC works

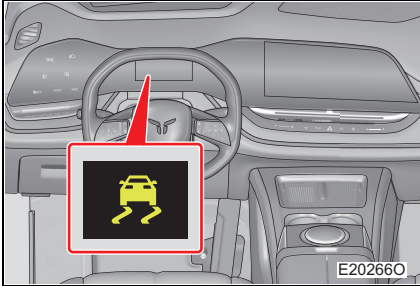

If the vehicle skids or the driving wheels idle, the indicator lamp will flash to indicate that the TCS/ESC is working.

## Disabling ESC

If the vehicle is trapped in snow or mud, the ESC may reduce the power output from the power system to the wheels. Disabling the system can be beneficial for the vehicle to rock back and forth, aiding in getting out of the trapped situation.

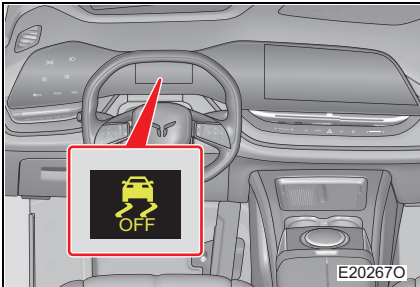

The ESC can be turned on and off in the driving settings interface of the in-vehicle infotainment system. When it is turned off, the ESC off indicator lamp on the instrument cluster comes on.

### ■ **Automatic response of ESC**

After turning off ESC/TCS and restarting the vehicle, or if the vehicle speed exceeds 70 km/h, the system will be reactivated automatically.

### ■ **Sound and vibration generated by ABS/HBA/TCS/ESC/CDP/CDD-S/HDC and AUTO HOLD**

- Noises may be heard from the front compartment when the vehicle is powered on or just after the vehicle starts. This sound does not indicate a failure in these systems.
- Some normal conditions may occur during the operation of the above systems. These conditions do not indicate a fault.
  - Vibration may be felt through the vehicle body and steering wheel.
  - The motor sound may be heard when the vehicle stops.

 **WARNING****■ Handling of wheels and suspension**

Faulty wheels or modified suspension can have an impact on the driver assistance system and may lead to system failure.

**■ ABS cannot work effectively under the following conditions:**

- The limits of ground grip of tires are exceeded.
- The vehicle skids when driving on slippery roads at high speed.

**■ Braking distance of ABS on special road surface**

ABS is not designed to shorten the braking distance of the vehicle. Be sure to keep a safe distance from the vehicles driving ahead under the following conditions:

- The vehicle drives on muddy, gravel or snowy roads.
- The vehicle drives with tire chains.
- The vehicle drives on bumpy roads.
- The vehicle drives on cratered or uneven roads.

**■ TCS may not work effectively under the following conditions:**

When the vehicle drives on slippery roads, even if the TCS works normally, it may not control the driving direction or meet the power requirements. Do not drive the vehicle under the condition that the vehicle may lose stability and power.

**■ When ESC is activated**

If the indicator lamp flashes, be sure to drive carefully. Otherwise, accidents may occur easily.

**■ When ESC is off**

Take special care and drive at a speed suitable for road conditions. In this case, the ESC can ensure the stability and driving force of the vehicle. If not necessary, do not turn off the ESC.

**■ Replacement of wheels**

Ensure that all wheels have the same specifications, brand, tread pattern and load capacity. In addition, ensure that the tire pressure meets the requirements specified on the tire pressure label. If the vehicle is equipped with different wheels, the ABS and EPS may not work properly. For details of tire or wheel replacement, please contact an authorized FAW Hongqi dealer.



**7-1. Parking control**

Front and rear parking radar.....	316
Around view monitor (AVM) .....	321
Auto parking assist (APA)* .....	327
Rear automatic emergency braking (RAEB)* .....	337

# Front and rear parking radar

The front and rear parking radar system consists of a control unit and ultrasonic sensors. These sensors can measure the distance between the vehicle and obstacles. According to the change of the distance to obstacles within the detection area, the speaker sounds at different frequencies, and at same time, the multimedia display screen and instrument cluster display information about the distance and orientation of the obstacle. When using the system, be sure to pay attention to the surrounding area.

■ Sensor type

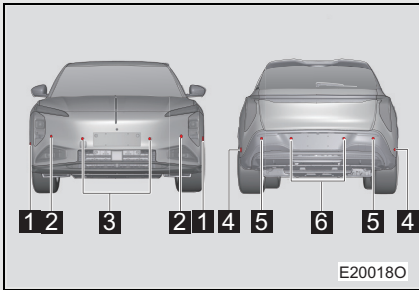

- 1 Front side radar sensor
- 2 Front corner radar sensor
- 3 Front central radar sensor
- 4 Rear side radar sensor
- 5 Rear corner radar sensor
- 6 Rear central radar sensor

■ Turning on and off parking radar

When the vehicle is not in P position and the vehicle speed is lower than 15 km/h, the parking radar turns on automatically. When the vehicle speed is higher than 15 km/h, the parking radar turns off automatically.

## Radars setting

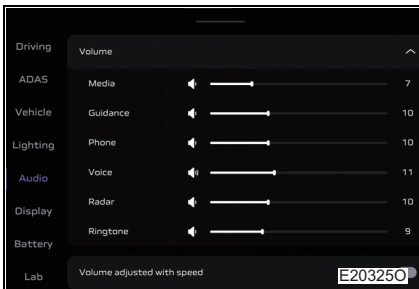

The radar alarm volume can be set in the sound setting of in-vehicle infotainment system. (See P.193)

## Display

- When an obstacle is detected

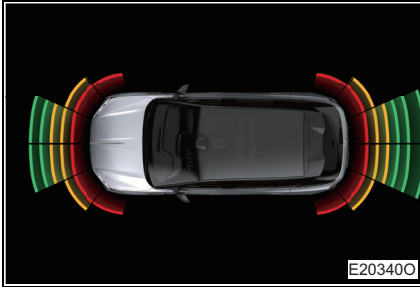

When the radar sensor detects an obstacle, corresponding image is displayed on the multimedia display according to the position and distance to the obstacle.

The slow-moving area, warning area and danger area are indicated in green, yellow and red respectively.

## Obstacle distance detection

When an obstacle is detected, the color block corresponding to the sensor will continuously illuminate.

- Parking slow-moving area information indication of central radar sensor



Front central radar sensor

The distance to the obstacle is 80 ~ 120 cm

Rear central radar sensor

The distance to the obstacle is 80 ~ 150 cm

If the obstacle is detected within this range, a green indicator bar is indicated on the display and the speaker sounds to warn the driver.

### ■ Parking warning area information indication of corner radar sensor

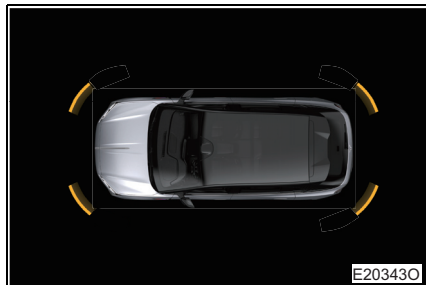

#### Corner radar sensor

The distance to the obstacle is 40 ~ 60 cm

If the obstacle is detected within this range, a yellow indicator bar is indicated on the display and the speaker sounds to warn the driver.

### ■ Parking warning area information indication of central radar sensor



#### Central radar sensor

The distance to the obstacle is 40 ~ 80 cm

If the obstacle is detected within this range, a yellow indicator bar is indicated on the multimedia display screen and the speaker sounds to warn the driver.

### ■ Parking danger area information indication of radar sensor



#### Radar sensor

The distance to the obstacle is 1 ~ 40 cm

If the obstacle is detected within this range, a red indicator bar is indicated on the display and the speaker continuously sounds to warn the driver.



## Farthest detection distance of sensors

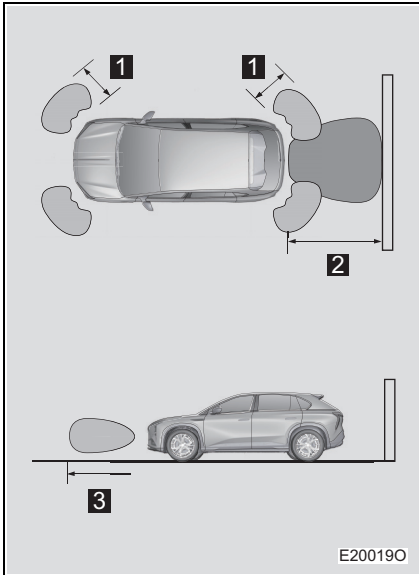

- 1 About 60 cm
- 2 About 150 cm
- 3 About 120 cm

The figure shows the farthest distance detected by radar sensors. (Note: Radar sensors cannot detect obstacles that are extremely close to the vehicle.)

Depending on the shape of the obstacle, the detection range of the radar sensors may vary.

### ■ Detection information of sensors

- Certain vehicle conditions and surrounding environments may affect the sensor's ability to correctly detect obstacles. For example:
  - There is dirt, snow or ice on the sensors.
  - Sensors are obscured.
  - The vehicle is obviously tilted.
  - The vehicle is on particularly bumpy roads, slopes, gravel roads or grass.
  - There is a lot of noise in the vicinity of the vehicle, such as sounds from vehicle horns, motorcycle engines and pneumatic braking of large vehicles or other strong noises that can produce ultrasonic waves.
  - There is another vehicle equipped with parking assist sensors nearby, and the sensors are working.
  - The vehicle is equipped with a fender antenna mast or wireless antenna.
  - The vehicle is equipped with a towing eye.
  - Bumpers or sensors are strongly impacted.
  - The vehicle is approaching a high or bent curb.
  - In hot or cold weather.

In addition to the above cases, traffic signs and other objects may sometimes be judged by sensors as being closer than their actual distance due to their specific shape.

- The shape of an obstacle may prevent the sensors from detection, especially the following obstacles.
  - Wires, fences, ropes, etc.
  - Cotton, snow and other materials that absorb radio waves.
  - Objects with sharp edges and corners.
  - Low obstacles.
  - High obstacles with the upper part extending toward the vehicle.



### **WARNING**

#### **■ Warnings for using the front and rear parking radar**

To avoid accidents, please observe the following precautions:

- Do not install anything within the working range of the sensors.
- Parking radar system is only a driver assistance system. Do not rely on it too much. The driver must drive carefully. When necessary, intervene proactively to avoid danger.
- The driver is the primary controller of the vehicle, and must always have control on the vehicle and take full responsibility for the vehicle.
- When the vehicle speed is too fast, the system will exit. The driver must drive carefully.



### **CAUTION**

#### **■ Precautions for vehicle washing**

Do not flush the sensors with water or steam. Otherwise, the sensors may fail.

# Around view monitor (AVM)

The AVM gives indications through the multimedia display screen, which is convenient for the driver to clearly view and understand the surrounding conditions of the vehicle, and at the same time judge the relative orientation and distance of obstacles, so as to achieve safe and easy parking.

The images used in this section are examples only and may differ from those actually indicated in the vehicle.

## Activating and deactivating AVM

### ■ Activation

There are 3 methods to enter the AVM:

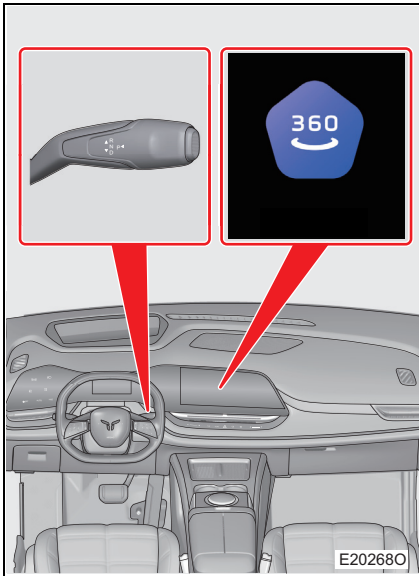

Method 1: Set the shift lever to R position to activate the AVM.

Method 2: When the vehicle speed is lower than 20 km/h, turn on 360 around view in extended application of in-vehicle infotainment system to activate the AVM.

Method 3: When the vehicle speed is lower than 20 km/h, the automatic activation of AVM function is set to ON, turn on the left/right turn signal lamp and enter AVM.

### ■ Deactivation

Touch button X on the screen, or the vehicle speed exceeds 20 km/h, or set the shift lever to P position for a period of time to exit AVM.

## Screen modes of AVM

The AVM features several screen modes. The driver can choose the corresponding mode based on specific needs.

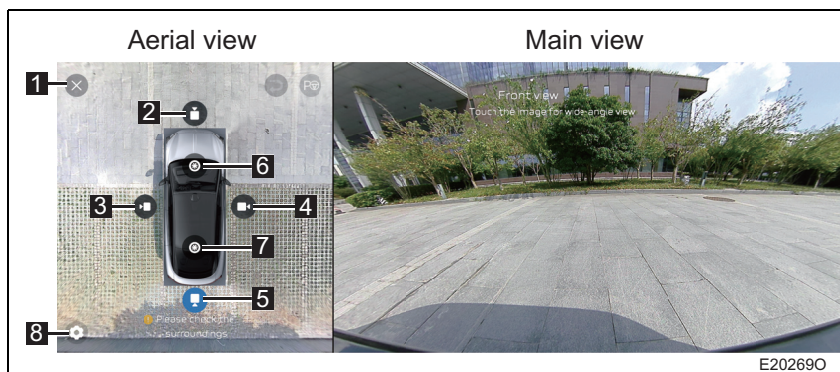

### 1 Exit button

Click and exit the AVM.

### 2 Front view

Display the front view and aerial view.

### 3 Left view

Display the left view and aerial view.

### 4 Right view

Display the right view and aerial view.

### 5 Rear view

Display the rear view and aerial view.

### 6 Front wheel side view

You can select to check the left and right wheel side views of front wheel.

### 7 Rear wheel side view

You can select to check the left and right wheel side views of rear wheel.

### 8 Setting

The object detection, underbody blind spot filling and automatic activation of AVM can be set.

- Underbody blind spot filling: After enabled, as the vehicle moves, the blind spot under the vehicle is filled with visual image to achieve the visual effect at the bottom.
- Automatic activation of AVM\*: You can set to activate AVM by turning on the left/right turn signal lamp when approaching an obstacle or when driving at low speed.
- Rear emergency braking: When the vehicle moves backwards after turning on, it will apply brake on the vehicle in case of emergency.

- When the turn signal lamps are turned on with AVM activated, the screen mode is automatically switched to the corresponding left/right view. When the turn signal lamps are turned off, the previously selected screen mode is restored.

## Parking assist line

The indication on the screen assists the driver in complete parking, and the parking guide lines are dynamically adjusted according to different angles of the vehicle.

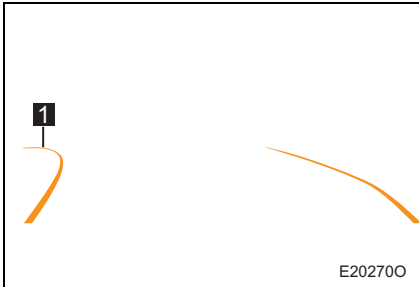

### 1 Parking guide line

It represents the expected vehicle trajectory as the steering wheel rotates.

### ■ When setting the AVM self-starting function to ON

- When the shift lever is set to D position and the vehicle speed is lower than 20 km/h, if there are obstacles around the vehicle or turn signal lamps are turned on, the radar image interface will pop up on the display.
- After the radar image system is turned on, when the vehicle speed is higher than 15 km/h, the system will exit. When the vehicle speed is lower than 12 km/h, the radar image system will work again.

### ■ When setting the AVM self-starting function to OFF

- When the shift lever is set to D position and the vehicle speed is lower than 15 km/h, if there are obstacles around the vehicle or turn signal lamps are turned on, the system will not pop up AVM interface automatically.

## Around view camera

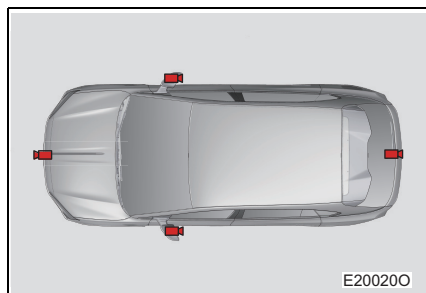

Around view cameras are installed at the front grille, back door and left and right exterior rearview mirrors respectively.

When the image cannot be spliced normally due to door opening, the corresponding area display may be misaligned. When the camera cannot transmit the image normally, the image of the corresponding area is abnormal with a prompt message.

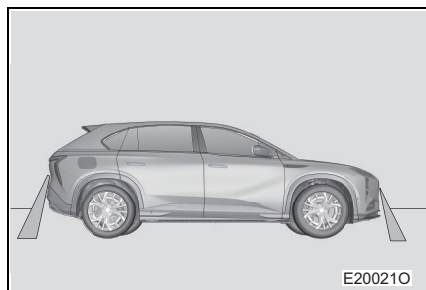

The area that the camera can monitor is limited. Objects near the corners of the bumpers or under the bumpers are not displayed on the screen.

The area displayed on the screen may change with the vehicle direction or the road conditions.



If the cameras receive strong light (for example, sunlight reflected by the vehicle body), they may produce the smear effect\*<sup>1</sup> unique to the camera.

\*<sup>1</sup>: When the cameras are used to transmit images, the light source seems to have a vertical stripe extending up and down.

 **WARNING**

■ **The AVM is only a driver assistance system. Do not rely on it too much.**

- The driver is the primary controller of the vehicle, and must always have control on the vehicle and take full responsibility for the vehicle.
- Please drive carefully and visually confirm the situation around the vehicle. It is very dangerous to reverse only by observing the display screen, which may lead to accidents or collisions with objects. The AVM is only a visual auxiliary system. The image on the display screen may be different from the actual situation.

■ **When using AVM**

Please observe the following precautions to prevent serious personal injury or even death.

- Do not rely solely on the AVM when reversing.
- Visually check and confirm through the rearview mirror that the selected path is clear.
- The displayed distance between the object and the plane may be different from the actual distance.
- The aerial view of AVM can only show close objects, and the cameras will not show objects outside the field of view.
- The moving object detection function can only detect moving objects at low speed, and some objects may be missed during detection. Please remain vigilant during driving.
- Do not use this system when the cameras can not work normally.

■ **Conditions affecting AVM**

- If the vehicle is hit, the position and mounting angle of the camera may change. Please contact an authorized FAW Hongqi dealer for vehicle inspection.
- If the temperature changes sharply, for example, when the vehicle is splashed with hot water in cold weather, this system may not work properly.
- If the camera is dirty, it may not transmit a clear image. Rinse it with water and wipe it clean with a soft cloth. If the camera is very dirty, clean it with neutral detergent and wipe it.

### **WARNING**

- When the system temperature is low, the displayed image may darken and the moving image may be slightly distorted.
- Under the conditions of rain, snow, fog and low visibility, the camera image may not be clear.
- Situations where AVM should not be used
  - On icy, slippery or snowy roads.
  - Tire chains or an emergency spare tire are used.
  - On an uneven or bended road, such as a bend or slope.
- If the tire is changed, the guide line position indicated on the display screen may deviate. For tire change, please consult an authorized FAW Hongqi dealer.
- Depending on the vehicle conditions (number of occupants, amount of luggage, etc.), the guide line position indicated on the display screen may change. Before operation, make sure to visually check the conditions behind and around the vehicle.
- When the radar sensor or around view camera fails, the radar detection results of obstacles or the camera image output may be affected. At this time, the AVM interface will display the fault icon and text prompt in the corresponding area, please contact an authorized FAW Hongqi dealer to inspect and repair the vehicle.



# 7-1. Parking control

## Auto parking assist (APA)\*

APA measures the length of the parking spaces on both sides of the road using ultrasonic waves and cameras. After the appropriate parking space is selected, the system will automatically control the vehicle to perform parking to park in the selected parking space. APA includes auto parking-in and auto parking-out. They can be selected through the multimedia display.

Before using the APA, be sure to check the automatic parking steps, precautions and warnings described in this section to prevent accidents.

### Entering APA

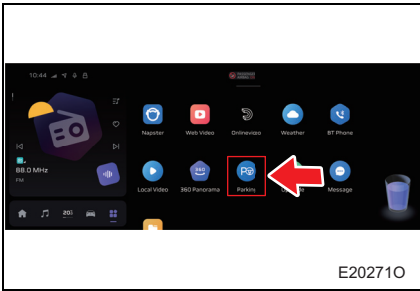

Method 1: Click the parking button in the extended application of the in-vehicle infotainment system to enter the automatic parking interface.

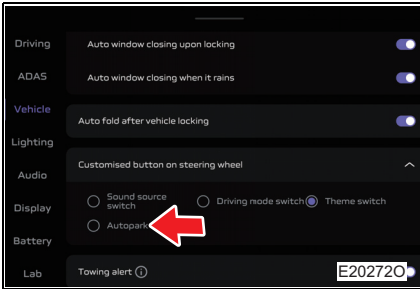

Method 2: After setting the steering wheel \* button function to automatic parking, press the steering wheel "\*" button to enter the automatic parking interface.

## How to use auto parking-in

### Step 1 Selecting parking space

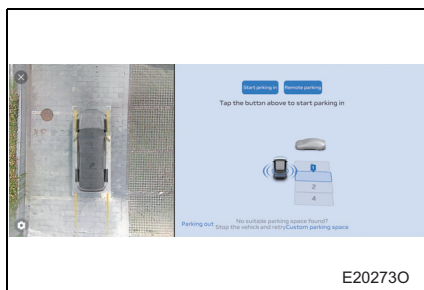

#### Method 1: Automatic parking space locating

Driving at a speed of lower than 20 km/h, the system will recognize the parking spaces on both sides of the driving direction. When the system finds the parking spaces, the parking spaces will be displayed in blue. The driver can touch available parking space on the display as the target parking space.

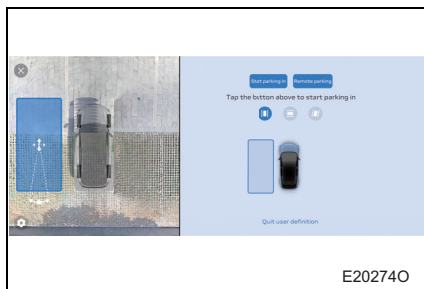

#### Method 2: Manual mode selection

When no proper parking space is searched while driving, the system will prompt you to try to customize the parking space. After selecting the custom parking space mode and select the type of parking space (parallel, vertical or inclined), the corresponding parking space frame will appear in the aerial view, drag and rotate the target parking space frame to move it to the available parking area. If the parking space frame is red, it means that the vehicle can not be parked in that area, and you need to adjust the position of the target parking space frame on the screen. When the selected place meets the parking

conditions, the parking space frame will turn blue. At the same time, the space will be marked in the virtual view. The start parking-in button becomes highlighted at this time.

## Step 2 Parking control

During the parking, the parking process will be displayed on the display. Three methods can be used to control moving and stopping of the vehicle.

### Method 1: Using in-vehicle infotainment system display

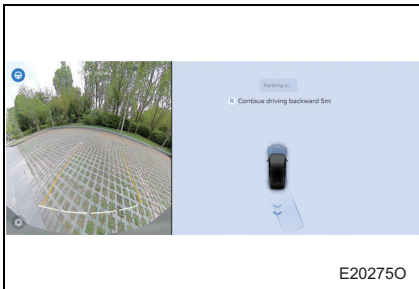

With the target parking space confirmed, depress the brake pedal, touch the "Start parking-in" button, and release the brake pedal to start parking; Or shift the gear to P, apply the EPB and touch the "Start parking-in" button to start parking.

### Method 2: Using parking button on remote control key

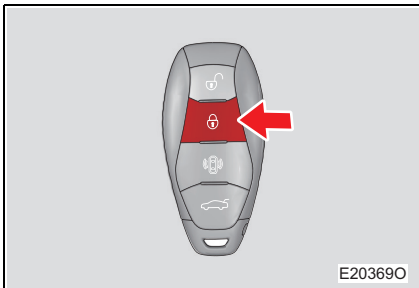

With the target parking space confirmed, click the remote parking button. After getting off, double click the lock button to start the parking-in function with remote control key.

During parking, the driver can pause parking by depressing the brake pedal, or clicking any button on the smart key. Release the brake pedal, double click the lock button on smart key and continue to park the vehicle. When parking the vehicle with remote control key, press trunk lid opening/closing button on the smart key twice to exit from using the key to park vehicle.

### Step 3 Parking power-off control

**Manual power-off:** When the driver has completed parking in the vehicle, power off the vehicle manually.

**Automatic power-off:** After the driver completes the parking with the remote control key or mobile phone APP outside the vehicle, the EPB will turn on automatically, and then the vehicle will power off automatically.

## How to use auto parking-out

### Step 1 Selecting the parking-out type

**Method 1:** Select on the display of the in-vehicle infotainment system

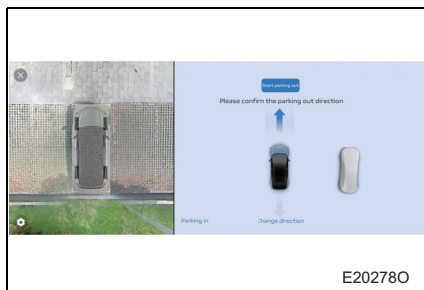

After entering the APA through the display of in-vehicle infotainment system, four types of parking-out can be selected : Vertical backwards, vertical forward, parallel left, and parallel right.

**Method 2:** Select with the parking button on remote control key

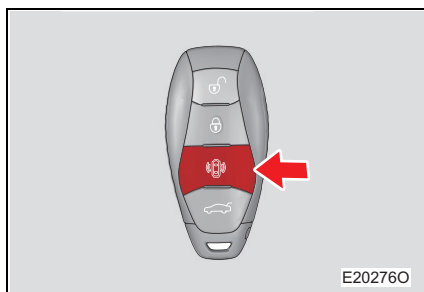

When starting the vehicle remotely with remote control key and moving out the vehicle using parking button on remote control key, the parking-out mode cannot be selected, and the vehicle can only be controlled to move forward or backward.

**Step 2** Parking-out control

## Method 1: Using in-vehicle infotainment system display



After selecting parking-out type, depress the brake pedal, touch the "Start parking-out" button, and release the brake pedal to start parking-out; Or shift the gear to P, apply the EPB and touch the "Start parking-out" button to start parking-out.

## Method 2: Using parking button on remote control key

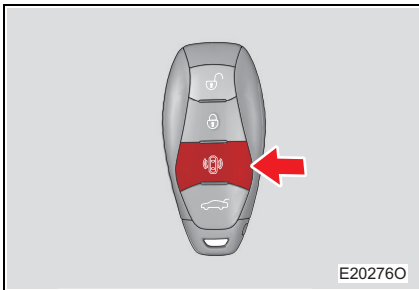

Press the lock button on the smart key once, then press the parking button on the smart key twice to start the vehicle. Press and hold the unlocking or locking button on the smart key, move out the vehicle vertically forward or backward in a straight line. After releasing the button, the vehicle stops. Press back door opening/closing button on the smart key twice to exit from using the key to park vehicle.

**■ Parking operating conditions:**

- In the process of searching for a parking space, the vehicle speed should be lower than 20 km/h; when it exceeds 20 km/h, slowdown will be prompted.
- No one is operating the steering wheel during parking.
- ESC OFF switch is not activated.
- ESC/ABS/TCS is not working.
- This system and related system function have no fault.

**■ Parking exit conditions:**

- The vehicle speed is more than 30 km/h during the process of searching a parking space.
- The driver operates the steering wheel.

- The driver depresses the accelerator pedal.
- The driver operates the shift lever.
- The parking canceling button is pressed.
- Parking is not completed even after exceeding the maximum number of movements after the automatic parking is activated.
- The parking space condition is not satisfied.
- When suspend recovery conditions are met and parking can be continued, the driver does not press the continue parking button within the specified time.
- EPB is activated.
- SACC is activated.
- ESC OFF switch is activated.
- ESC/ABS/TCS functional intervention.
- This system or related system has other relevant abnormal conditions or faults.

 **CAUTION**

- **The driver is the primary controller of the vehicle, and the APA is only a driver assistance system. Although the system can provide assistance to the driver during parking, it should not replace the driver to park the vehicle and the driver must be responsible for the parking. During parking, the driver should pay attention to the surrounding environment of the vehicle and control the vehicle if necessary to avoid danger.**
- **To ensure the success rate and safety of parking system, the system needs to be used in the following environmental conditions:**
  - The road surface is flat, the height of obstacle is less than 5 cm, and the slope does not exceed 4 degrees.
  - The parking space lines are clear and the parking space is large enough.
  - The weather is good, and the driver can see the environment near the parking space clearly and unobstructedly.
  - The driving road is dry and non-slip.
- **In the process of automatically searching for parking spaces, the following situations should be paid attention to:**
  - The vehicle needs to move close to the parking space. Failure to do so may cause the parking space not to be recognized.
  - The steering angle of the vehicle should not be excessive, otherwise it may cause failure of the parking space recognition.
  - For the parking space with marked line, the vehicle speed should not be higher than 20 km/h; For the parking space without marked line, the vehicle speed should not be higher than 15 km/h, otherwise it may cause failure of the parking space recognition.
  - Rain, snow, fog or dark light conditions may reduce the recognition rate of parking spaces.
  - When the parking space is too small, the parking space lines are not clear, or the parking space is irregular, it may cause failure of parking space search.
  - In the process of searching for a parking space, the image can only assist the driver, and the driver needs to pay attention to the surrounding environment in real time.



## CAUTION

- **In the process of automatically parking, the following situations should be paid attention to:**
  - The distance prompting function may have blind spots, and the driver needs to pay attention to the surrounding environment in real time.
  - Insufficient parking space may cause failure of parking.
  - Steep slope may cause failure of parking.
  - Slippery roads may cause failure of parking.
  - Uneven road surface, steps or low obstacles may cause failure of parking.
  - During parking, the driver should not operate the pedals, shift lever and steering wheel, otherwise the parking process will be terminated.
- **If a tire needs to be replaced, please make sure that the size of the replacement tire is exactly the same as that of the original tire, and check the four-wheel alignment parameters.**
- **When controlling a vehicle with a key, delays in communication and vehicle response may cause the vehicle not to stop immediately after releasing the button. Driver needs to observe the surroundings in advance.**
- **When parking the vehicle with a key, ensure that the driver is next to the vehicle. If the vehicle can not be stopped by the key command, the driver can open any door to interrupt the parking.**



 **WARNING**

- Due to the blind spot of the sensor, pay attention to low and small obstacles, and the corners and sides of the vehicle during parking.
- For specific limitations of the sensor, please refer to the relevant description of the parking radar.
- Pay attention to whether there is enough space when parking.
- There is a delay in the parking brake, so the driver should make a judgment in advance and stop the vehicle if the danger is found.
- Please pay special attention to people, animals and various obstacles around the vehicle, the sensor has a blind spot that cannot be detected.
- When searching for a parking space or during parking, please be aware that there are no obstacles in the parking space, such as stones, thin poles or tow bars, as the system may not detect such obstacles.
- The system may not recognize the surface or structure of certain objects (e.g., wire fences, fluffy snow, angular pillar, etc.). Therefore, please re-check that there is enough space in the parking space and surroundings before parking the vehicle.
- If the parking radar system detects an obstacle, the obstacle may disappear from the sensor detection range after the vehicle approaches (this is highly likely to happen when detecting obstacles that are too high and too low), thus not detecting these items. Do not ignore the warning from the parking distance warning system, otherwise the vehicle may be at risk of collision.
- Due to the influence from various external sound field and electromagnetic field (e.g. other vehicles using ultrasonic ranging, air pressure, engine noise, electric control gears, induction loops, etc.), the system cannot achieve absolute immunity to interference.
- The immunity to interference and detection performance of ultrasonic ranging may be reduced by environmental conditions and obstacle reflection properties, which are determined by the physical properties of ultrasonic propagation.

 **WARNING**

- **The installation position of the sensor has an important impact on the system performance, which is reflected in the reflection from the vehicle bumper surface itself, ground echo reflection and detection range.**
- **Avoid cleaning the sensor with a high pressure washer or steam cleaner to prevent damaging the sensor. When cleaning the vehicle, you should use a smaller water flow to rinse the sensor surface for a short time and keep at least 10 cm away.**
- **The propagation of sound waves in air is influenced by the physical properties of refraction and diffraction phenomena. Temperature differences in the air is one of the most important factors in generating a non-uniform propagation medium, leading to acoustic diffraction.**
- **The detection performance of ultrasonic detection equipment can be affected by the following factors:**
  - Hot vehicle exhaust.
  - High temperature asphalt road.
  - Summer breeze.
  - Temperature stratification.
- **When there is a temperature difference between the bumper and the ambient air (common in winter), temperature stratification may occur. This can lead to acoustic wave diffraction, and in certain bumper structures may pose a risk of false alarms due to reflected echoes.**
- **Some important factors that can lead to reduced detection range or failure of detection:**
  - Snow or sludge adhering to the bumper surface.
  - Plaster or ice adhering to the sensor surface.
  - High acoustic attenuation (e.g., in dry, hot environments).
  - Heavy rain or in foam.
  - Obstacles with wave-absorbing materials.
  - Flat type obstacles with angles facing the sensor and reflected echoes occurring only in a specific angular range.

# Rear automatic emergency braking (RAEB)\*

The operation range of the RAEB is 2~4 km/h. When the vehicle may collide with the rear vehicle (or pedestrians, non-motor vehicles, motor vehicles, obstacles, etc.) in an emergency, if the driver fails to perform emergency braking, the system will assist the driver in applying brake to avoid or reduce the collision injury.

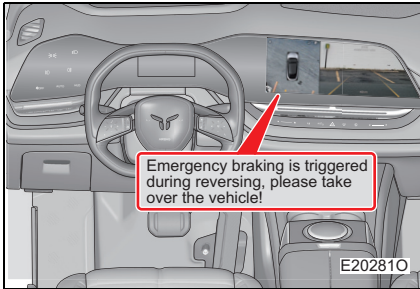

When the RAEB function works, the instrument cluster displays warning information

## Turning on/off RAEB

The RAEB can be turned on and off through the settings interface of the AVM system. (See P.322)

- **The RAEB function is activated when the RAEB is on and the vehicle meets all the following conditions:**
  - Gear is in R, or gear is in D/N position and the vehicle is slipping backwards.
  - The ultrasonic radar operates normally.
  - The range of vehicle speed is 2~4 km/h.
  - Brake system has no fault.
  - The steering speed of the driver is slower.
  - The parking function is not activated.
- **During activation of RAEB, when the vehicle detects any of the following conditions, the RAEB releases the brake:**
  - The driver turns off RAEB function.
  - Brake system has fault.
  - The steering speed of the driver is too quick.
  - The vehicle determines that the rear obstacle is out of the rear ultrasonic radar detection range.

- With RAEB applied, when it is detected that the driver depresses the brake pedal, accelerator pedal deeply or shifts the shift lever, the brake will be released.
- **The RAEB may not work properly under the following conditions:**
  - RAEB system has fault.
  - The function of the sensor is limited due to factors such as being blocked, out of focus, glare, or due to bad weather such as heavy snow, heavy fog, heavy rain, etc.
  - Mechanical failure is caused by factors such as sensor calibration failure.
- **Adjusting or calibrating RAEB**

Adjust or calibrate the RAEB under the following conditions, otherwise the RAEB may not work properly:

  - Replace the rear ultrasonic radar.
  - Replace the rear camera.
  - The four wheels are aligned.
  - The rear bumper is hit or deformed.

For calibration, contact an authorized FAW Hongqi dealer.



### **WARNING**

- **The RAEB is only a driver assistance system. Do not rely on the RAEB too much. The driver must drive carefully.**
- **The driver is the primary controller of the vehicle, and must always have control on the vehicle and take full responsibility for the vehicle.**
- **The RAEB may not recognize modified or decorated vehicles with special appearance, the system may not work properly.**
- **For scenes like strong backlighting, road reflection, insufficient ambient lighting, etc., the RAEB may not work normally. The driver must drive carefully.**
- **If rear ultrasonic radars are displaced due to collision, the RAEB may degrade or fail. Please calibrate the RAEB in time. Do not use uncalibrated ultrasonic radar.**
- **After RAEB is activated and the vehicle is applied brake and stops, the driver should take control of the vehicle timely to start the vehicle safely.**
- **RAEB only recognizes specific obstacles in the rear central area of the vehicle and applies brake.**
- **The operation speed range of the RAEB can be optimized through OTA upgrade, please refer to the upgrade announcement for details.**

**8-1. Parking assist**

Electronic parking brake  
(EPB) ..... 340  
AUTO HOLD ..... 342

**8-2. Get-off**

Door opening  
warning\* ..... 344

## 8-1. Parking assist

# Electronic parking brake (EPB)

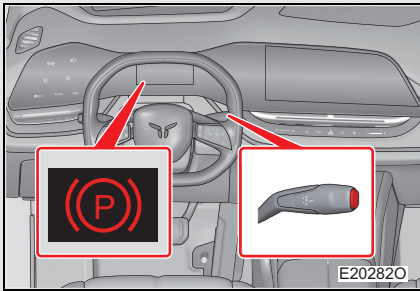

### Automatic application/release of EPB

Depress the brake pedal, and set the shift lever to P position, so the EPB is automatically applied; set the shift lever from P to D/R position to automatically release the EPB.

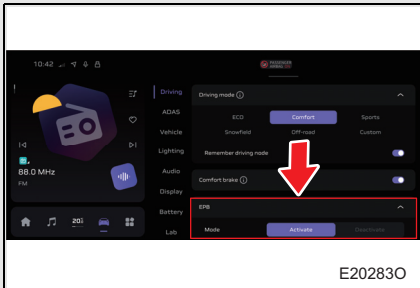

### Manually application/release of EPB

Method 1: Manually apply or release EPB function through the driving settings interface of the in-vehicle infotainment system. (See P.188)

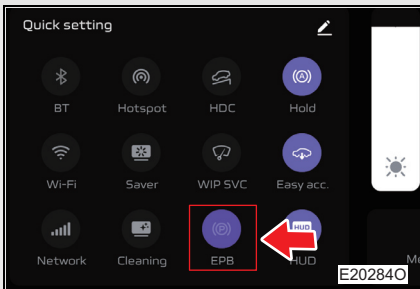

Method 2: Manually apply or release EPB function through the shortcut menu of the in-vehicle infotainment system. (See P.183)

When the vehicle power supply is set to OFF mode, Press P position button to apply EPB manually.

### Other features of EPB

- HHC: The driver fastens the seat belt and closes the door. Before starting the vehicle, if the EPB is applied manually, the system will automatically release the EPB according to the torque balance principle, so that the vehicle will not slip down the slope and start smoothly.
- Controlled deceleration for parking brake (CDP): When the vehicle is running, long press P position button, so the vehicle will brake until it stops.

### ■ AUTO HOLD after power-off

When the driver stops the vehicle and turns off vehicle power supply, the EPB is automatically applied. The AUTO HOLD after power-off can be turned on and off through the driving settings interface of the in-vehicle infotainment system. (See P.188)



### CAUTION

#### ■ Precautions before driving

- Release the EPB completely before driving. In case of failure (e.g., electrical failure), the rear brake disc locked by the EPB can only be unlocked by mechanical method. It is recommended that you contact an authorized FAW Hongqi dealer for handling.
- When the EPB is not released, the red indicator lamp  is on. Driving the vehicle at this time will cause the brake components to overheat, thus affecting the braking performance and aggravating the brake wear.

# AUTO HOLD

In the AUTO HOLD ready state, depress the brake pedal deeply again after the vehicle is stopped or directly depress the brake pedal deeply until the vehicle stops so as to activate AUTO HOLD. At this time, the vehicle will hold the brake when the brake pedal is released. When the brake pedal or accelerator pedal is depressed with the gear in D/R, the AUTO HOLD will be deactivated by the system.

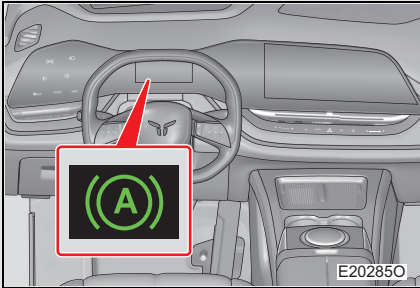

When the AUTO HOLD is activated, the AUTO HOLD indicator lamp of the instrument cluster comes on.

## ■ Turning on and off AUTO HOLD

The AUTO HOLD can be turned on and off through the driving settings interface of the in-vehicle infotainment system. (See P.188)

---

## ■ AUTO HOLD function

- AUTO HOLD can also serve as a Hill Hold Control (HHC) function. However, on steep slopes, the AUTO HOLD may not stop the vehicle. In this case, it is necessary to apply the brake manually.
- After the AUTO HOLD is activated for a period of time, the EPB will take over the AUTO HOLD.

## ■ Operating conditions of AUTO HOLD

- The driver's door is closed.
- The driver has fastened the seat belt.
- The AUTO HOLD function in the in-vehicle infotainment system is set to on.
- Depress the brake pedal deeply again after the vehicle is stopped; or directly depress the brake pedal deeply until the vehicle stops and then release the brake pedal.



 **WARNING****■ Parking on slippery roads**

The AUTO HOLD does not prevent the vehicle from moving if the ground grip of the tires is exceeded. Do not use this system on slippery roads.

 **CAUTION****■ When parking**

The AUTO HOLD cannot be used for long-term parking. If the vehicle needs to be parked for a long time, please apply the EPB.

# Door opening warning\*

The system assesses the risk by considering the relative position, relative speed and relative acceleration of the vehicle to the side and rear oncoming vehicles, as well as the door opening intention of the driver and passengers. If there is danger in opening the doors at this time, the driver will be prompted by audible and visual alarms.

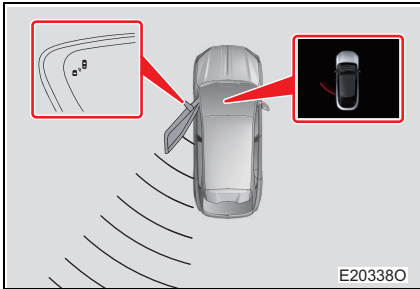

When the shift lever is not set to R position and the vehicle speed is 0~3 km/h, if another vehicle approaches within 2.5 m transversely and 50 m longitudinally behind the vehicle and the door unlocks, exterior rearview mirror warning indicator lamp on the corresponding side will come on, and the instrument cluster will display a warning message. At this time, when the door is opened, exterior rearview mirror warning indicator lamp on the corresponding side and door ambient lamp on the corresponding side will come on, and the system will issue a warning sound simultaneously to remind the driver that there is a danger when opening the door. When the vehicle speed is greater than 5 km/h, the function is turned off.

## Turning on/off door opening warning system

The door opening warning system can be turned on and off through the driver assistance settings interface of the in-vehicle infotainment system. (See P. 189)

- **The door opening warning system may not give an alarm or may expand the alarm range under the following conditions:**
  - A large amount of snow or ice gathers near radar sensors.
  - There are fixed obstacles on the roadside (e.g., tunnel wall, cement barrier of viaduct, metal billboard, etc.).

 **CAUTION**

- **Be careful not to impact the rear bumper during parking. Otherwise, the sensors in the bumper may be displaced or damaged, which may cause the system to shut down automatically or affect the system function.**
- **In order to ensure the normal operation of the system, the sensors in the bumper must be kept clean and not be covered by other objects.**
- **Only the paint approved by our company can be applied to the rear bumper. Other kinds of paint may cause limited functions or failure of the system.**
- **If this system does not work normally, please turn it off immediately, and contact an authorized FAW Hongqi dealer for repair.**
- **After relevant components of the door opening warning system are repaired, calibration is required. For details, please contact an authorized FAW Hongqi dealer.**
- **The door opening warning system is only an auxiliary reminder, and cannot completely avoid vehicle collision. Before opening the door and getting off, please check the rearview mirrors and give a glance to rear areas.**
- **Under special working conditions such as wet weather, the door opening warning system may give false alarms or miss alarms, which are normal phenomena.**
- **When the rear radar is blocked, the system will not work. Therefore, it needs to be cleaned in time.**

 **WARNING**

- The door opening warning system is only a driver assistance system. Do not rely on it too much. The driver must drive carefully.
- The driver is the primary controller of the vehicle. The door opening warning system is only an auxiliary reminder. The driver must always have control of the vehicle and take full responsibility for the vehicle.
- Turn off the radar detection system when towing the vehicle or some accessories (e.g., bicycle carrier) are installed at the rear of vehicle. Otherwise, the radio waves emitted by the radar may be blocked, resulting in abnormal operation of the system.
- The door opening warning system can detect targets such as vehicle, electric motorcycle and bicycle. If target vehicles have characteristics of irregular shape, modification, painted surface, etc., the recognition effect cannot be guaranteed. The recognition of pedestrians, animals or other objects cannot be guaranteed too. At this time, the driver must drive carefully.

**9-1. Important information**

Hazard warning  
lamp ..... 348  
SOS alarm ..... 349

**9-2. Countermeasures in  
case of an emergency**

If the vehicle needs to be  
towed ..... 350  
If the vehicle is found  
to be abnormal ..... 355  
If you have a flat tire . 356  
If the power system  
cannot start ..... 357  
If the key is lost ..... 358  
If the key fails to work  
normally ..... 359  
If 12 V battery power  
is low ..... 361  
If your vehicle  
overheats ..... 365  
If an electrical fire  
occurs ..... 367  
If vehicle gets  
trapped ..... 368  
If driving on water-  
logged road ..... 370  
If you have a burst  
tire ..... 371  
Emergency opening  
of back door ..... 372

## 9-1. Important information

# Hazard warning lamp

**When the vehicle breaks down, please stop by the roadside and turn on the hazard warning lamp. If the vehicle cannot be moved due to breakdown, please turn on the hazard warning lamp and place a warning triangle behind the vehicle. If necessary, please wear a reflective vest.**

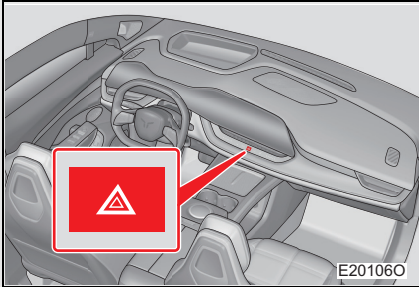

Press the hazard warning lamp switch to make all turn signal lamps flash; press it again to turn off the hazard warning lamp.

### CAUTION

#### ■ Preventing a low 12 V battery

When the vehicle power supply is not turned on, if it is not necessary to use the hazard warning lamp, turn it off.

## 9-1. Important information

# SOS alarm

If you need help in an emergency, press and hold the SOS alarm switch for more than 3 seconds. The emergency rescue call will initiate, and the SOS lamp will change from on to flashing. After receiving your call for help, the service center will arrange proper rescue service.

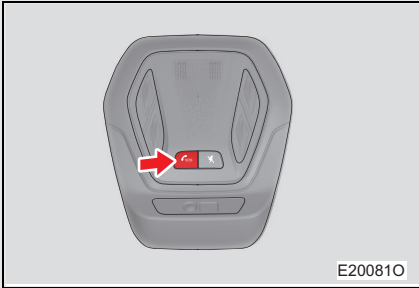

SOS alarm switch is located at the front interior lamp.

### CAUTION

- Please use the SOS alarm switch when needed.
- When the vehicle is in an accident, the vehicle is in no network or cannot provide power supply to the emergency call system in the vehicle, manual or automatic SOS alarm is not supported.

## 9-2. Countermeasures in case of an emergency

### If the vehicle needs to be towed

If the vehicle needs to be towed, FAW suggests that a flatbed carrier tow truck is used and the towing is handled by an authorized FAW Hongqi dealer or a professional rescue company. It is strictly prohibited to tow the vehicle in P position.

#### Before towing

If the following conditions occur, the drivetrain may be faulty. Please contact an authorized FAW Hongqi dealer before towing the vehicle.

- The power system is running normally, but the vehicle cannot move.
- The vehicle has abnormal noise or vibration.

#### It is strictly forbidden to use a bumper lift tow truck for towing

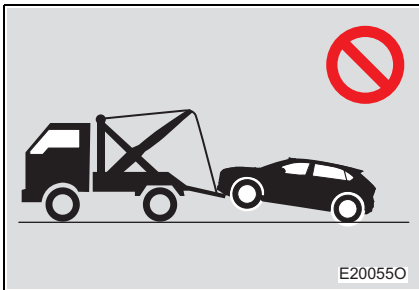

Do not use a bumper lift tow truck for towing, as it may cause damage to the vehicle body.

#### Towing from the front with a wheel lift tow truck

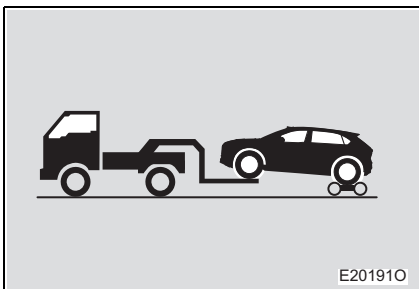

Locate the towing trolley under the rear wheels.



## Towing from the rear with a wheel lifting tow truck

### ■ 4WD

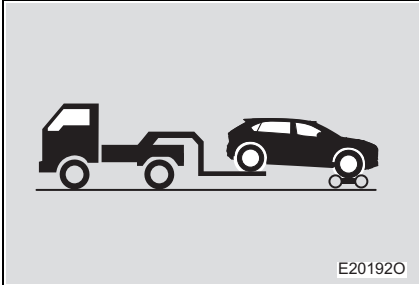

Locate the towing trolley under the front wheels.

### ■ 2WD

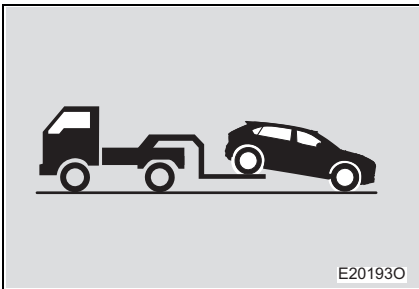

The front wheels and suspension of the vehicle must be in good condition.

## Towing with a flatbed carrier tow truck

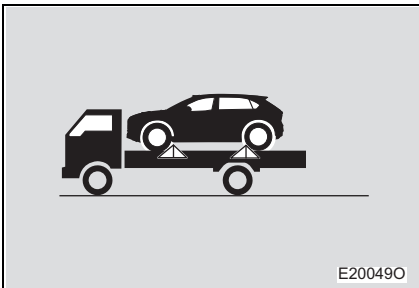

Apply the EPB, turn off the vehicle power supply.

Use wedges under 4 wheels to prevent the vehicle from moving.

As shown in the figure, tie the tires to the bottom plate of the tow truck to secure the vehicle.

### Emergency towing

If the carrier tow truck cannot be found in an emergency, fasten the towing cable or towing chain to the towing eye and set the shift lever to N position to temporarily tow the vehicle. This method can only be used for towing at low speed and short distance on hard pavement.

The driver must sit in the vehicle and control the steering wheel and brake pedal. The wheels, drivetrain, steering wheel and brakes must be in good condition.

### Emergency towing steps

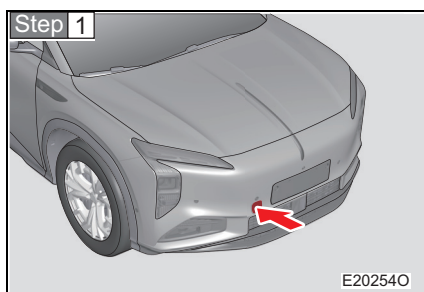

Press the left side of towing eye hole cover to detach the towing eye hole cover.

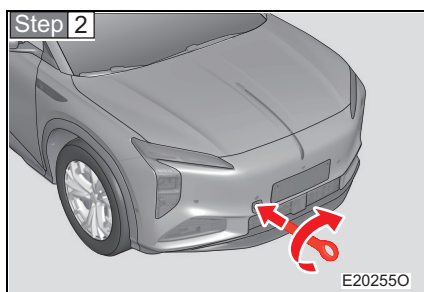

Insert the towing eye into the hole and tighten it slightly by hand.

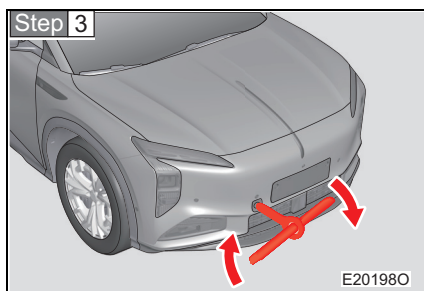

Tighten the towing eye with the auxiliary tool.

**Step 4** Secure the towing cable or towing chain firmly to the towing eye.

Be careful not to damage the vehicle body.

**Step 5** Enter the vehicle being towed and start the vehicle.

If the vehicle cannot start, turn the vehicle power supply to ON mode.

**Step 6** Set the shift lever to N position.

---

### ■ Towing

- If the power system does not work, the power assist for the brakes and steering wheel will not work, making steering and braking more difficult.
- If the shift lever cannot be set to N position, do not carry out emergency towing. Otherwise, the vehicle may be damaged during towing.

### ■ Towing a trailer

FAW recommends that you do not use the vehicle to tow a trailer, or install any towing equipment or tow any wheelchair, scooter, bicycle, etc. using the towing equipment. The vehicle is not designed for towing any trailer or as a mounting carrier of towing equipment.

### ■ Towing eye

Towing eye is stored in the front compartment storage box. (See P.356)

 **WARNING**

Please observe the following precautions. Failure to do so may result in serious personal injury or even death.

■ **When towing**

Be sure to transport the vehicle with all four wheels off the ground.

If the vehicle is towed with the driving wheels touching the ground, the drivetrain and related parts may be damaged.

■ **Towing**

● For towing with ropes, the tow truck starts only when the ropes are tightened, and the ropes must be kept tightened all the time during towing. Otherwise, excessive pulling force will be generated on the towing eye and ropes, resulting in damage to the towing eye or ropes and personal injury.

● Do not turn the vehicle power supply to OFF mode. The steering wheel may be locked and inoperable.

■ **Installation of towing eye on the vehicle**

Ensure that the towing eye is securely installed. Otherwise, the towing eye may loosen during towing, which may cause accidents.

 **CAUTION**

■ **During towing with a wheel lift tow truck, prevent damage to the vehicle.**

When the vehicle is lifted, make sure that there is enough ground clearance at the landing end of the vehicle for towing. Otherwise, the vehicle may be damaged during towing.

■ **During towing with a bumper lift tow truck, prevent damage to the vehicle.**

Regardless of towing at the front or rear of the vehicle, do not use a bumper lift tow truck.

■ **During towing with a flatbed carrier tow truck, prevent damage to the vehicle.**

● Do not pass the wedges. Otherwise, the tires may be damaged.

● Do not tie other parts (such as suspension) except for tires.

### If the vehicle is found to be abnormal

**If any of the following symptoms are found, the vehicle may need to be adjusted or repaired. Please contact an authorized FAW Hongqi dealer as soon as possible.**

- Visible symptoms
  - There is a liquid leaked under the vehicle.  
(It is normal for the A/C to drip water after use)
  - Flat tire or uneven tire wear.
  - Continuously and abnormally high coolant temperature.
- Audible symptoms
  - Excessive tire noise during turning.
  - Abnormal noise related to suspension system.
  - Noise related to power system.
- Operation symptoms
  - Noticeable decrease in power.
  - The vehicle pulls to one side seriously during braking.
  - The vehicle pulls to one side seriously during driving on a flat road.
  - The brake system malfunctions, or the brake pedal feels soft and nearly reaches the floor.

## 9-2. Countermeasures in case of an emergency

### If you have a flat tire

Please use tire repair kit in driver's tool for repair.

Please refer to the instructions in the tire repair kit for specific operation methods.

■ Driver's tool

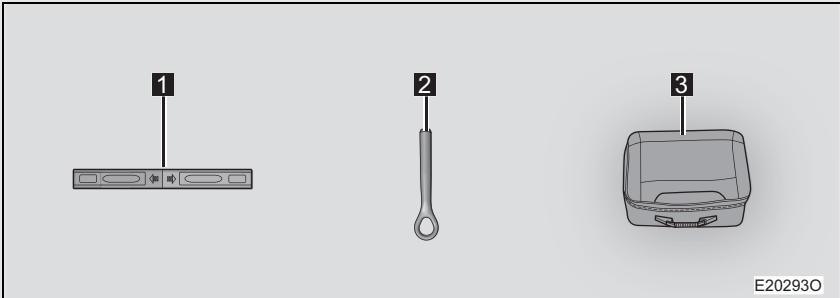

1 Warning triangle

2 Towing eye

3 Tire repair kit assembly

#### WARNING

##### ■ Do not drive the vehicle with flat tires

- Do not continue driving the vehicle when any tire leaks.
- Otherwise, even if the driving distance is short, tires and the vehicle may be damaged, which will lead to unfeasible repair and even cause traffic accidents.

##### ■ Before repairing tires

- Park the vehicle on a solid and level road.
- Set the shift lever to P position.
- Vehicle power supply is set to OFF mode.
- Turn on the hazard warning lamp and place the warning triangle.

#### CAUTION

- Pay attention to the surrounding environment when repairing tires to avoid accidents.

### If the power system cannot start

**If the power system cannot start even after correct start steps are performed (see P.226), consider the following reasons.**

- Even if correct start steps are followed, the power system cannot start.

The failure may be caused by one of the following conditions:

- The vehicle's power battery is low.
- Key may not work properly.
- The gear control system may be faulty.
- An electrical failure (e.g., depleted key battery or blown fuse) can cause an power system failure. However, emergency measures can be taken to start according to the fault type.
- The immobiliser system may be faulty. (See P.68)

- Interior lamps and headlamps are dim, or horns do not sound or sound with low volume.

The failure may be caused by one of the following conditions:

- The 12 V battery is low or depleted. (See P.361)
- The terminals of the 12 V battery may be loose or corroded.

- The interior lamps and headlamps do not come on, or the horn does not sound

The failure may be caused by one of the following conditions:

- The terminals of the 12 V battery may be disconnected.
- The 12 V battery may have run out of power.

If the faults cannot be eliminated or the maintenance steps are unclear, please contact an authorized FAW Hongqi dealer.

## If the key is lost

**If the smart key is lost or stolen, please provide the remaining keys to an authorized FAW Hongqi dealer as soon as possible. After the keys are re-matched, the lost or stolen key will become invalid. Unauthorized modification or non-genuine spare parts may lead to system failure.**



## 9-2. Countermeasures in case of an emergency

### If the key fails to work normally

If communication between the key and the vehicle is interrupted (see P.119) or the key cannot be used due to insufficient battery power, the PEPS and wireless remote control will be invalid. At this time, the following steps can be followed to open the doors or start the power system.

#### Locking and unlocking the doors

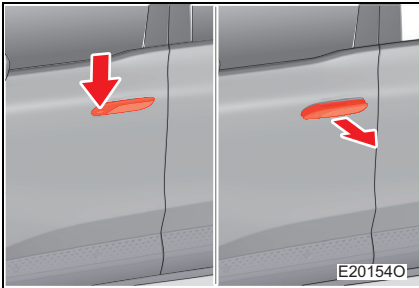

Press the front of driver's door handle to raise it, then pull the middle part and pull it out vertically.

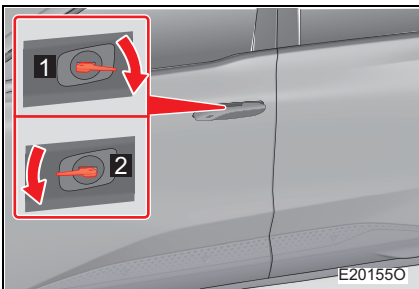

Pull the door handle and use the mechanical key to lock and unlock the vehicle.

- 1 Locking the door
- 2 Unlocking the door

## Backup start mode

When the key battery is low, the backup start mode should be used.

**Step 1** Depress the brake pedal.

At this time, the multifunction display in the instrument cluster will prompt that the key cannot be recognized.

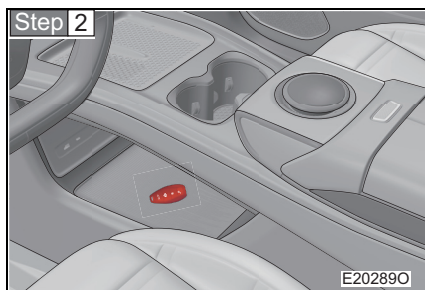

**Step 2**

Place the smart key in the storage box.

**Step 3** Depress the brake pedal to start the power system.

If the power system still cannot start, please contact an authorized FAW Hongqi dealer.

### ■ Replacing key battery

If the key battery is low, replace it in time. (See P.410)

## 9-2. Countermeasures in case of an emergency

### If 12 V battery power is low

If 12 V battery power is low, the following measures can be adopted to start the power system.

You can contact an authorized FAW Hongqi dealer or a professional repair shop.

If you have a set of jumper cables (or auxiliary cables) and another vehicle with a 12 V battery, you can jump start your vehicle according to the following steps.

**Step 1** Remove the 12 V battery trim panel and positive terminal cover.

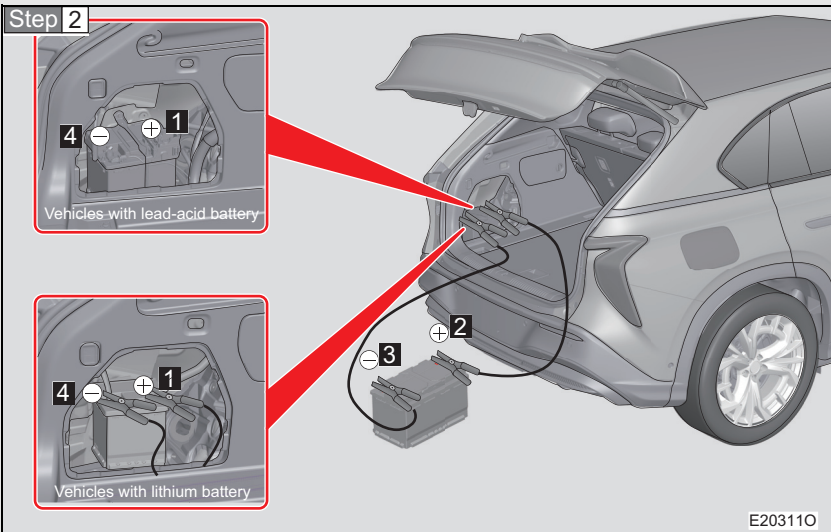

Connecting jumper cables.

**1** Connect to the 12 V battery positive (+) terminal of your vehicle.

**2** Connect to the 12 V battery positive (+) terminal of the other vehicle.

**3** Connect to the 12 V battery negative (-) terminal of the other vehicle.

**4** Connect to the 12 V battery negative (-) terminal of your vehicle.

**Step 3** Start the engine of the other vehicle. Increase the engine speed slightly and keep it for about 5 minutes to recharge the 12 V battery of your vehicle.

**Step 4** Keep the engine of another vehicle running, and then turn the power supply of your vehicle to ON mode.

**Step 5** Remove the jumper cables in the reverse order of connection once the vehicle is started successfully.

Once the vehicle is started, drive it to an authorized FAW Hongqi dealer for inspection as soon as possible.

---

### ■ Charging the 12 V battery

Due to natural discharge and the consumption of certain electrical equipment, the power stored in the 12 V battery gradually depletes even when the vehicle is not in use. If the vehicle is not in use for a long time, the 12 V battery may be depleted and the vehicle may fail to start. (After the vehicle starts, the 12 V battery is charged automatically)

### ■ Replacing 12 V battery

Use the 12 V battery that meets the manufacturer's standards.



### CAUTION

#### ■ Handling jumper cables

- Only use a 12 V auxiliary battery.
- When connecting or disconnecting jumper cables, be careful not to entangle the cables with the cooling fan.

 **WARNING****■ Removing 12 V battery terminals**

- Be sure to disconnect the negative (-) terminal first. If the positive (+) terminal is removed and it touches any metal in the surrounding area, it may spark and cause a fire, possibly an electric shock, resulting in serious injury or even death.

**■ Preventing fire or explosion of 12 V battery**

The 12 V battery may release flammable gases, therefore, be sure to observe the following precautions to avoid accidental ignition of flammable gas:

- Make sure that the jumper cables are connected to the correct terminals and will not accidentally touch any terminals other than the correct ones.
  - Do not let the other end of the jumper cable connected to the "+" terminal touch any other part or metal surface in this area, such as bracket or unpainted metal.
  - Do not let the "+" and "-" clamps of the jumper cable contact with each other.
  - Do not use any open flames, smoke or use matches or lighters near the 12 V battery.
  - Please pay attention when connecting the negative cable to the vehicle. Sparks may be generated when connecting the second jumper cable. Sparks may cause gas explosion near the battery and cause personal injury.
- Do not use lead-acid battery to charge lithium battery. Because lithium battery charging requires a higher voltage, please use a charger to charge.**

 **WARNING**

■ **Once the vehicle is started after charging, drive it to an authorized FAW Hongqi dealer for inspection as soon as possible.**

■ **Precautions for 12 V battery**

The 12 V battery contains toxic and corrosive acidic electrolytes. Therefore, be sure to observe the following precautions when handling the 12 V battery:

- Always wear goggles when handling the 12 V battery and be careful not to let any 12 V battery electrolyte come into contact with your skin and clothing or vehicle body.
- Do not lean over the 12 V battery.
- If the 12 V battery electrolyte comes into contact with your skin or eyes, rinse the affected area immediately with water and seek medical attention. Cover the contact area with a damp sponge or a piece of damp cloth until you see a doctor.
- Always wash your hands after handling the 12 V battery bracket, terminals, and other 12 V battery-related parts.
- Keep children away from the 12 V battery.
- When arranging jumper cables, it should be kept away from moving parts. It is dangerous to connect jumper cables to the moving parts (such as cooling fan) or the surroundings. When the vehicle starts, the cable may get stuck, leading to serious personal injury.
- If the battery is aging and continues use may cause the battery to emit foul odor gas, which may endanger the health of passengers. Please contact an authorized FAW Hongqi dealer to check the battery as soon as possible.

## 9-2. Countermeasures in case of an emergency

### If your vehicle overheats

**The vehicle may be overheated under the following conditions.**

- The alarm for high coolant temperature is issued or a decrease in power is felt.
- Steam comes out beneath the front compartment cover.

#### ■ Countermeasures

**Step 1** Park the vehicle in a safe place and turn off the A/C system.

**Step 2** Check whether steam comes out from beneath the front compartment cover.

#### **If steam comes out:**

Turn off the vehicle power supply. After steam dissipates, carefully lift the front compartment cover and restart the vehicle power supply.

#### **If steam does not come out:**

Keep the vehicle power supply on, and carefully lift the front compartment cover.

**Step 3** Check whether the cooling fan is operating.

#### **If the fan runs:**

Wait until the coolant temperature begins to drop, and turn off the vehicle power supply.

#### **If the fan does not run:**

Turn off the vehicle power supply, and contact an authorized FAW Hongqi dealer.

**Step 4** After the system is cooled sufficiently, check the coolant level, and check the cooling system for leakage.

**Step 5** Add coolant if necessary. (See P.390)

If there is no coolant in case of emergency, contact an authorized FAW Hongqi dealer.

 **WARNING**

■ **Precautions for inspection:**

When opening the front compartment cover for inspection, be sure to observe the following precautions to avoid accidents or personal injuries.

- If steam comes out beneath the front compartment cover, do not open the front compartment cover before steam dissipates. The vehicle may be very hot, resulting in serious injuries such as scalding.
- When the vehicle is powered on, do not approach the fan.
- When the power system and radiator are hot, do not release the coolant filler cap. Otherwise hot coolant and steam may be released under pressure, resulting in serious scalding and other injuries.

 **CAUTION**

■ **Adding coolant**

Add coolant slowly after the power system is cooled sufficiently. If cold coolant is added too quickly when the power system is hot, the power system will be damaged.

■ **Preventing damage to cooling system**

Please observe the following precautions:

- Prevent foreign matters (such as sand or dust) from entering into coolant.
- Do not use any coolant additives.



## 9-2. Countermeasures in case of an emergency

### If an electrical fire occurs

**If an electrical fire occurs, please follow the following operations and contact an authorized FAW Hongqi dealer as soon as possible.**

- Protect yourself and do not inhale smoke.
- Call for help.
- Carbon dioxide fire extinguisher or foam fire extinguisher should be used when extinguishing fires on electrical equipment.
- Do not use a carbon dioxide fire extinguisher to extinguish fires on individuals, as there is a risk of suffocation.

## 9-2. Countermeasures in case of an emergency

### If vehicle gets trapped

**In case of wheel idling or trapping in mud or snow, perform the following operations.**

- Step 1** Set the shift lever to P position and turn off the vehicle power supply.
- Step 2** Remove mud, snow or sand around the trapped tires.
- Step 3** Place wooden blocks, stones or other materials under all tires to help increase the ground grip of the tires.
- Step 4** Vehicle power supply is set to ON mode.
- Step 5** Set the shift lever to D or R position, and depress the accelerator pedal carefully to drive the vehicle out of the trap.

#### ■ Emergency towing

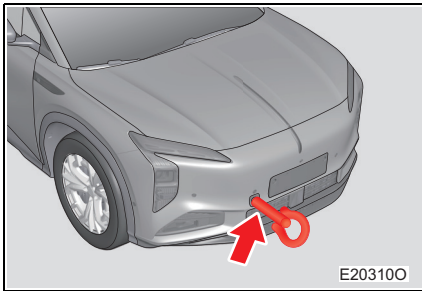

- If the vehicle is trapped or immobile, the towing eye can be used to tie the towing cable or chain to another vehicle to tow the vehicle in an emergency.
- For details, refer to "If the vehicle needs to be towed" in this chapter. (See P.352)
- It is not recommended to tow other vehicles with your vehicle.

#### **WARNING**

##### ■ Driving the vehicle out of the trap

If the vehicle is driven out of the trap by pushing the vehicle from the front and rear, make sure that the surrounding area is spacious and unimpeded to avoid colliding with other vehicles, objects or people. When the vehicle is to be driven out of the trap, it may suddenly rush forward or backward, so extra care shall be taken.

##### ■ When operating the shift lever

Do not depress the accelerator pedal during gear shifting, otherwise the vehicle may accelerate suddenly, resulting in a serious accident.

**CAUTION****■ Preventing damage to components**

- If the vehicle still cannot get out of the trap after several attempts, it is required to seek the assistance of a tow truck.

## 9-2. Countermeasures in case of an emergency If driving on water-logged road

**In case of accidental driving on a water-logged road and water entry, contact an authorized FAW Hongqi dealer for the following inspections:**

- Check the braking efficiency of brakes.
- Check the oil level and quality of the reducer (if the lubricating oil appears milky, it indicates water contamination and should be replaced).
- Check the lubrication of the drive shaft, bearings, joints, etc.



In case of driving on a water-logged road, it is easy to cause power system malfunction, short circuit of electrical components, and water ingress are likely to occur. Please do not attempt to turn on the vehicle power supply after the power system has been shut down, otherwise it may cause serious damage to the power system.

## 9-2. Countermeasures in case of an emergency

### If you have a burst tire

**In the event of tire burst or rupture during driving, keep calm.**

Hold the steering wheel firmly and depress the brake pedal slowly to decelerate the vehicle. If you perform emergency braking or turn the steering wheel sharply, you are prone to lose control of the vehicle.

Please determine if it is caused by tire burst or rupture under the following conditions:

- Steering wheel jitter.
- Abnormal vehicle vibration.
- Abnormal vehicle inclination.

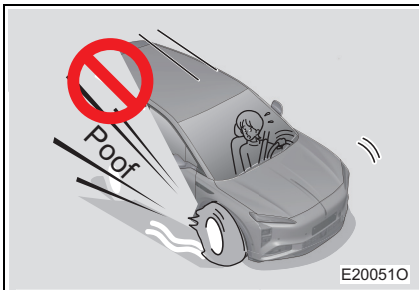

Do not drive with a flat tire.

Driving with a flat tire is so dangerous that accidents are likely to occur. In addition, tires, rims, suspensions and body will be damaged. In this case, replace the tires promptly or contact an authorized FAW Hongqi dealer.

## 9-2. Countermeasures in case of an emergency

### Emergency opening of back door

The following steps can be taken as emergency measures to ensure that the back door can be opened.

**Step 1** Enter the trunk area via folding the rear seat back.

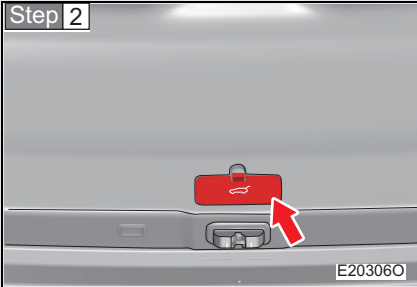

Open the emergency unlocking cover on back door.

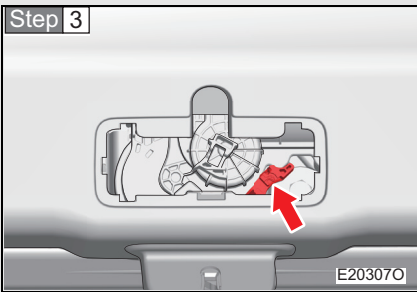

Push the back door unlocking cross-pin to open the back door.

#### **WARNING**

■ **When opening or closing the back door manually in an emergency, be careful to prevent injuries.**

- Do not allow children or persons in need of assistance to operate the vehicle alone, otherwise they may be trapped in the vehicle or trunk and cannot safely leave or perform self-rescue in the event of an emergency.
- With seasonal changes, the temperature in the locked vehicle may be very high or low, therefore, occupants especially children are prone to injury or illness and even death.
- When opening or closing the back door, take special care to ensure that there is no person between the back door and the vehicle body.

**CAUTION****■ Preventing damage to vehicle**

When opening or closing the back door in an emergency, be careful during removal and refitting of the parts, to avoid damaging the vehicle.





**10-1. Service and maintenance**

- Cleaning and protecting exterior trims of vehicle .....376
- Cleaning and protecting interior trims of vehicle .....378

**10-2. Maintenance**

- Precautions for maintenance .....382

**10-3. Maintenance by yourself**

- Precautions for maintenance by yourself .....385
- Front compartment cover .....388
- Front compartment ...389
- 12 V battery .....395
- Tire .....400
- Tire pressure .....403
- Wheel .....405
- A/C filter .....407
- Fragrance box\* .....409
- Replacing key battery .....410
- Checking and replacing fuse .....412
- Power battery .....414

**10-4. Specifications**

- Maintenance data ....418

# Cleaning and protecting exterior trims of vehicle

**The following operations help to protect the exterior trims of the vehicle and keep them in the best condition:**

- Rinse the body, wheelhouse and underbody with plenty of water from top to bottom to remove dirt and dust.
- Wipe the body with a sponge or a piece of soft cloth (such as suede cloth).
- Clean the part with the traces that are difficult to remove using detergents and rinse it thoroughly with water.
- Remove water.
- In case of aging of the waterproof coating, wax the vehicle body.

Make sure that the surface of the body is clean and free of water droplets and the body is cooled before waxing the body.

---

### ■ Automatic vehicle washing

- Fold the exterior rearview mirrors before washing the vehicle. Rinse the front part of the vehicle first. Be sure to unfold the exterior rearview mirrors before driving.
- The brushes used at the automatic washing station may scratch the surface of the vehicle and damage the paint.

### ■ High-pressure vehicle washing

- Do not place the nozzle for vehicle washing too close to the window.
- Before vehicle washing, check that the charging port cover is properly closed.

### ■ Aluminum wheels

- Immediately remove any adhered dirt using a neutral detergent. Do not use hard brushes or abrasive detergents. Do not use highly corrosive or strong detergents.
- Do not wash the wheels with detergent when they are very hot (e.g. after driving for long distance in hot weather).
- After washing the wheels with detergent, rinse them immediately.

### ■ Bumper

Do not scrub the bumper with abrasive detergent.

 **WARNING**
**■ Washing vehicle**

Do not rinse the interior of the front compartment with water, otherwise the electrical components may be short-circuited, possibly resulting in a fire.

 **CAUTION**
**■ Preventing aging of body and body paint and corrosion of body and components (such as aluminum wheels)**

- Wash the vehicle immediately after the following conditions occur:
  - After driving by the seaside
  - After driving on salt-alkali roads
  - If coal tar or tree sap is present on the paint surface
  - If dead insects, insect droppings or bird droppings are present on the paint surface
  - After driving in areas contaminated with coal ash, oil fumes, mineral dust, iron dust or chemical substances
  - When there is severe dust or mud buildup on the vehicle
  - When liquids such as benzene and gasoline splashed on the paintwork
- Repair the paint promptly in case of peeling-off or scratch.
- To prevent the wheels from corrosion, remove dirt from them and store them in a place with low humidity.

**■ Cleaning the logo**

Wipe the logo on the front compartment cover with clean water or neutral cleaner. Do not wash the logo with alcohol or alcohol-containing liquid, phenol, anisole and other organic solvents, otherwise the logo is prone to crack.

**■ Cleaning the lamp**

- Be careful when cleaning the lamp. Do not use organic cleaners or hard brushes to clean the lamp, otherwise the lamp surface may be damaged.
- Do not wax the lamp surface, otherwise the lamp shade may be damaged.

# Cleaning and protecting interior trims of vehicle

**The following operations help to protect the interior trims of the vehicle and keep them in the best condition:**

■ **Protecting interior trims of vehicle**

Remove dirt and dust with a vacuum cleaner. Dampen a piece of cloth with warm water and wipe the dirty surface.

■ **Cleaning leather part**

- Remove dirt and dust with a vacuum cleaner.
- Dampen a piece of soft cloth with diluted detergent and wipe off the remaining dirt and dust through wiping.  
Use a neutral wool detergent solution with a diluted concentration of about 5%.
- Wring the damp cloth and wipe off the residual detergent thoroughly.
- Wipe off any residual moisture on the surface with a piece of dry soft cloth, and dry the leather in a cool and ventilated place.

■ **Cleaning artificial leather part**

- Remove floating dust with a vacuum cleaner.
- Apply neutral soapy solution to the artificial leather part.
- Soak the artificial leather part in the soapy solution for a few minutes, and wipe off the dirt and soapy solution with a piece of clean damp cloth.

■ **Cleaning wooden part**

- Gently wipe off the dust on the surface of wooden trims using cotton gauze.
- Gently wipe off the dirt on the surface of wooden trims using cotton gauze wet with a little neutral soapy solution.

**■ Maintaining leather part**

It is recommended that you clean the interior trims at least twice a year to maintain their quality.

**■ Maintaining wooden part**

It is recommended that you maintain the surface of wooden part at any time according to their condition.

**■ Cleaning carpet**

Clean the carpet with a proper foam cleaner available in the market. Apply the foam with a sponge or brush, scrub the carpet in overlapping circular motions, do not add water, and keep the carpet as dry as possible to achieve the best effect.

**■ Seat belt**

Clean the seat belt using a piece of cloth or sponge wet with neutral cleaner and lukewarm water. Regularly check the seat belt for excessive wear, damage or scratches.

**WARNING****■ Preventing entry of water into vehicle**

- Do not spill liquids into the interior of the vehicle, otherwise it may cause malfunctions or fires in electrical components.
- Do not let the airbag components or wires in the vehicle get wet, otherwise accidental deployment or malfunction of the airbag may be caused, resulting in serious injury or even death.
- When applying film to glass (including the front and rear windshields and side door glasses, etc.) or cleaning the interior trim, pay special attention to preventing water from entering the gap between the glass and the interior trim panel, otherwise the electronic components in the vehicle are prone to damage, resulting in vehicle fault.

**⚠ WARNING**

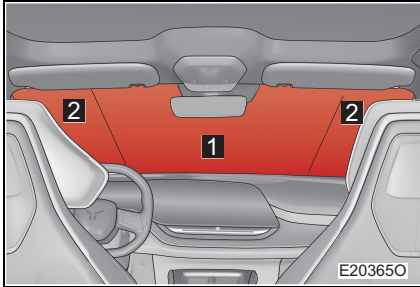

- When applying film to the front windshield or cleaning it, the spray water volume is less than 300 mL for the area **1** and less than 150 mL for the area **2**.

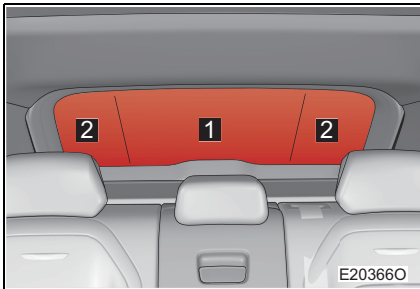

- When applying film to the rear windshield or cleaning it, the spray water volume is less than 200 mL for the area **1** and less than 100 mL for the area **2**.

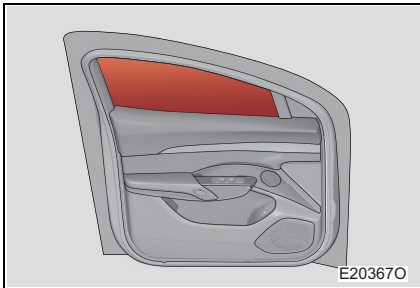

- When applying film to the adjustable window glass or cleaning it, the spray water volume is less than 200 mL.

It is recommended to use a towel to block the gap between the glass and the interior trim panel and wipe water upward as much as possible when applying the film.

■ **Cleaning interior trims (especially instrument panel)**

Do not use polishing wax or polishing cleaner, otherwise the instrument panel may reflect light on the windshield, which obstructs the driver's visibility, causing serious injury or even death.

**CAUTION**
**■ Cleaner**

- Do not use the following cleaners, otherwise the interior trims may be discolored or the paintwork may be streaked or damaged:

Organic substances such as benzene or gasoline, alkaline or acidic solutions, dyes and bleaches, etc.

- Do not use polishing wax or polishing cleaner, otherwise the paintwork of the instrument panel or other interior parts may be damaged.

**■ Preventing damage to leather surface**

To prevent damage and aging of the leather surface, please observe the following precautions:

- Wipe off the dust and dirt on the leather surface in time.
- Do not expose the vehicle to direct sunlight for a long time. Park the vehicle in a cool place, especially in summer.
- Do not place polyethylene, plastic or waxy articles on the leather trim, as they may stick to the leather surface when the interior temperature increases significantly.
- If too much moisture remains on the seat surface, the leather will be hardened, shrunk or deformed.

**■ Preventing entry of water into floor**

Do not clean the floor with water.

If the electrical components under the floor come into contact with water, the electrical system may be damaged, and the body may be rusted.

**■ Cleaning inner side of rear windshield**

- Do not clean the rear windshield with glass cleaner, otherwise its defogger heating wires may be damaged. Dampen a piece of cloth with warm water and gently wipe the rear windshield in a direction parallel to the heating wires.
- Be careful not to scratch or damage the heating wires.

# Precautions for maintenance

**To ensure the driving safety and economy, routine and regular maintenance are crucial.**

**As recommend by FAW, you should take the following maintenance measures:**

■ Regular maintenance

- Perform regular maintenance on the vehicle according to the maintenance schedule.

The maintenance intervals are determined according to the mileage or time interval (whichever comes first) in the maintenance schedule.

It is recommended to perform maintenance items even if the specified maintenance mileage or interval has been exceeded.

- Where can you have your vehicle maintained?

An authorized FAW Hongqi dealer is the most ideal service provider for maintenance.

The authorized FAW Hongqi dealer has advanced maintenance tools, equipment and genuine spare parts for the maintenance and service of your vehicle, and all after-sales service personnel have received professional management and technical training to ensure rapid and efficient completion of vehicle maintenance and repair, so that your vehicle can always have good technical performance.

The authorized FAW Hongqi dealer has invested significantly in special tools and maintenance equipment, which helps to provide better service for you.

With the service concept of "efficient, reasonable and value-added", the authorized FAW Hongqi dealer is committed to thoroughly performing all maintenance items for your vehicle.

Rubber hoses (for cooling, heating, brake systems) should be checked by professionals in strict accordance with the maintenance schedule.

Rubber hoses will be degraded over time, which will cause expansion, wear or rupture. Therefore, if any signs of deterioration or damage are observed in the hoses, please immediately contact an authorized FAW Hongqi dealer for replacement.



### ■ Precautions for maintenance by yourself

#### Can the vehicle be maintained by yourself?

If you have abundant basic knowledge of vehicle structure, inspection and maintenance and some basic tools, you can perform routine inspection and maintenance yourself. Simple instructions for maintenance by yourself are covered in this section.

It should be reminded that some maintenance work requires special maintenance equipment and professional skills and it is preferably performed by a qualified technician. Even if you are an experienced professional technician, it is still recommended that you contact an authorized FAW Hongqi dealer for standardized repair and maintenance. The dealer will record the maintenance information of your vehicle and help you apply for warranty service.

### ■ Does your vehicle need to be repaired?

Pay attention to changes in the performance and sound of the vehicle, as well as visual warnings indicating maintenance requirements. Some important signs are provided below:

- Noticeable decrease in power.
- Abnormal sound of motor.
- Liquid leakage under the vehicle. (Water dripping after use of A/C is a normal phenomenon)
- Flat tire, excessive tire noise during turning, or uneven tire wear.
- Pulling to one side during straight driving on a flat road.
- Abnormal sound related to the suspension component.
- Braking failure; soft brake pedal when being depressed; pedal almost touching the floor; pulling to one side during braking.
- Continuously high coolant temperature.
- Thermal management system fault lamp/coolant level warning lamp, etc. in the instrument cluster remains on.

If you find any of the signs mentioned above, contact an authorized FAW Hongqi dealer for adjustment or repair as soon as possible.



**WARNING**

■ **Improper maintenance**

Improper maintenance may cause serious damage to the vehicle and serious personal injury or even death.

■ **Precautions for battery handling**

Battery terminals and related accessories contain lead and lead compounds which can cause brain damage. Be sure to wash your hands after handling.

## Precautions for maintenance by yourself

**If the maintenance is to be carried out by yourself, correct procedures below must be followed.**

Item	Component and tool
Battery status (see P.395)	<ul style="list-style-type: none"> <li>• Warm water</li> <li>• Baking soda</li> <li>• Grease</li> <li>• Common wrench (For terminal bolts)</li> </ul>
Coolant level (see P.390)	<ul style="list-style-type: none"> <li>• Automobile long-life coolant</li> <li>• Funnel (for adding coolant only)</li> </ul>
Brake fluid level (see P.392)	<ul style="list-style-type: none"> <li>• Genuine brake fluid of FAW</li> <li>• Rag or paper towels, funnel (For adding brake fluid only)</li> </ul>
Fuse (see P.412)	<ul style="list-style-type: none"> <li>• Fuse with the same amperage rating as the original one</li> </ul>
Radiator and condenser (see P.391)	—
Tire pressure (see P.403)	<ul style="list-style-type: none"> <li>• Tire pressure gauge</li> <li>• Compressed air source</li> </ul>
Washer fluid (see P.393)	<ul style="list-style-type: none"> <li>• Washer fluid with antifreeze (For use in winter)</li> <li>• Funnel</li> </ul>

 **WARNING**

Many machineries are installed in the front compartment. They may rotate, get hot, or become energized suddenly. To avoid serious personal injury, please pay attention to the following matters.

■ **Handling parts in front compartment**

- Be careful not to touch the motor, radiator, etc. immediately after driving, as they may be very hot.
- Before opening the front compartment cover, be sure to turn off vehicle power supply, apply the EPB, carry the key with you, and wait till the motor cools down.
- Keep hands, clothing and tools away from the rotating fan.
- Do not leave any articles in the front compartment.  
After inspecting or maintaining the front compartment, do not leave any articles such as tool or cloth in it, otherwise it may cause fire, resulting in an accident.
- Do not smoke, generate sparks, or expose open flames to the areas near the front compartment cable or battery.
- Be especially careful when handling the battery. The battery contains poisonous and corrosive sulfuric acid.
- Be careful when handling the brake fluid as it may injure your hands or eyes and damage the paintwork.  
If the brake fluid spills on your hands or into your eyes, rinse the part stained with the fluid immediately with plenty of clean water. If you still feel unwell, seek medical attention.

■ **Working near electric fan or radiator grille**

Make sure that vehicle power supply is turned OFF.

When the vehicle power supply is in ON mode, if the A/C is turned on or the coolant temperature is very high, the electric cooling fan may run automatically.

■ **Goggles**

Wear goggles to protect your eyes from flying objects or splashing fluids.

**CAUTION****■ Too low or high brake fluid level**

The brake fluid level drops slightly when the brake pads are worn, which is normal. If the brake fluid reservoir needs to be filled with brake fluid frequently, it means that there may be a serious fault. In this case, contact an authorized FAW Hongqi dealer for vehicle inspection.

## 10-3. Maintenance by yourself

# Front compartment cover

**Unlock the front compartment cover from inside the vehicle to open it.**

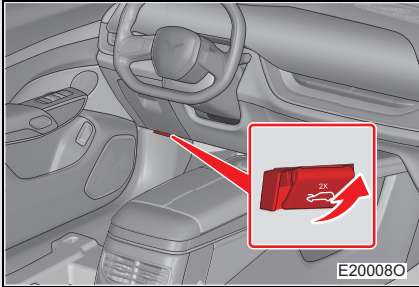

Pull the front compartment cover release handle inside the vehicle twice to open the front compartment cover.

### **WARNING**

#### ■ **Inspection before driving**

Check that the front compartment cover is fully closed and locked.

If the front compartment cover is not locked properly, it may suddenly open during driving, which will cause an accident, resulting in serious personal injury.

### **CAUTION**

#### ■ **Closing front compartment cover**

- Do not apply excessive force to prevent front compartment cover damage.
- Make sure that no tools, articles, etc. are left in the front compartment before closing the front compartment cover.

## 10-3. Maintenance by yourself

# Front compartment

Due to different model configurations, the picture is for reference only.

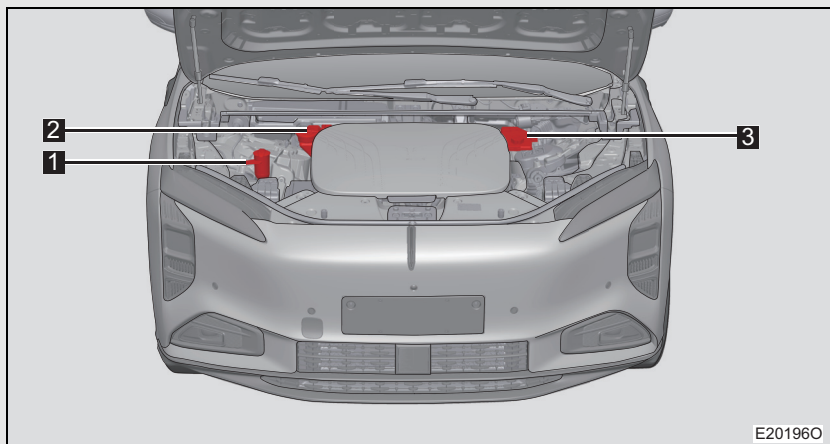

**1** Washer fluid reservoir

**2** Coolant reservoir

**3** Brake fluid reservoir

## Coolant

If the coolant level in the coolant reservoir is between the "MAX" (highest) and "MIN" (lowest) marks, it is normal.

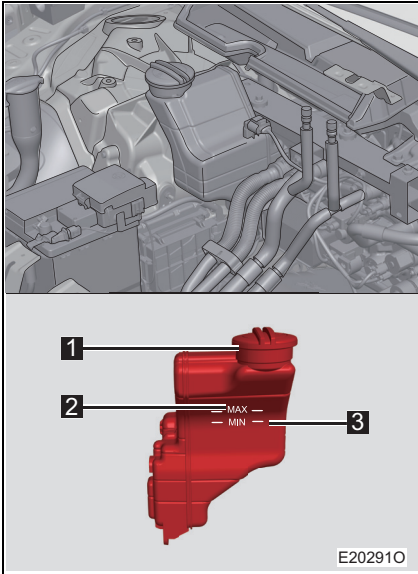

- 1 Reservoir cap
- 2 "MAX" (highest)
- 3 "MIN" (lowest)

If the coolant level is below the "MIN" mark, add the coolant to the normal level.

### ■ Decrease of coolant level shortly after the coolant is added

Visually check the components such as radiator, coolant reservoir and cooling pipe.

If no leaks are found, contact an authorized FAW Hongqi dealer for inspection of the cooling system.

### ■ Selecting coolant

Use the automobile long-life coolant throughout the year.

For more details of coolant, contact an authorized FAW Hongqi dealer.

### **WARNING**

#### ■ When the coolant temperature is very high

- Do not remove the coolant reservoir cap.

The cooling system may be under pressure, therefore, hot coolant may be sprayed out after the coolant reservoir cap is removed, causing scalding or other injuries.



 **CAUTION****■ Adding coolant**

Add the coolant specified by FAW to ensure normal lubrication, anti-corrosion and cooling performance.

Please read the instructions on the label of the coolant.

**■ Accidental splashing of coolant**

Always rinse off the coolant with water to avoid damaging the parts or paint.

**Radiator and condenser**

Check the radiator and condenser, and remove all foreign matters.

If the radiator or condenser is particularly dirty or abnormal, contact an authorized FAW Hongqi dealer for vehicle inspection.

 **WARNING****■ When radiator and condenser are very hot**

Do not touch the radiator or condenser to avoid scalding.

## Brake fluid

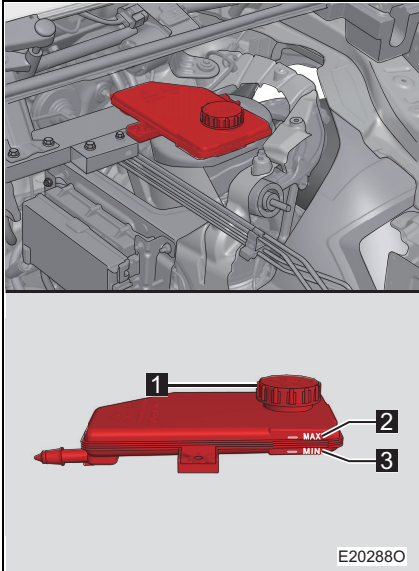

- 1 Brake fluid reservoir cap
- 2 "MAX" (highest)
- 3 "MIN" (lowest)

If the brake fluid level is below the "MIN" mark, add the brake fluid to the normal level.

### WARNING

#### ■ Precautions for addition of brake fluid

- It is very dangerous if the brake fluid is sprayed out. If the brake fluid enters the eyes, rinse them with plenty of water, and seek medical attention immediately.
- Do not spray the brake fluid onto your body or the electrical parts in the front compartment, otherwise it is likely to cause personal injuries or a fire.

#### ■ Too low brake fluid level

- It is very dangerous if the brake fluid level is too low. A too low fluid level indicates wear of the brake lining or leakage of the brake system. The brake may fail, resulting in a serious accident. If the fluid level is too low, check the brake.
- If the fluid level is too low, add the brake fluid until it reaches the "MAX" mark. Before adding the brake fluid, thoroughly clean the parts around the brake fluid reservoir cap.

### CAUTION

- The brake fluid will damage the paintwork. If the brake fluid is accidentally splashed onto the paintwork, wipe it off immediately.
- Using non-specified brake fluid can lead to damage in the system. Additionally, mixing different types of brake fluid may cause damage to the system.
- If the brake fluid needs to be added or replaced, consult an authorized FAW Hongqi dealer.
- Do not drop brake fluid onto the inverter, otherwise it may cause inverter failure.

### Washer fluid

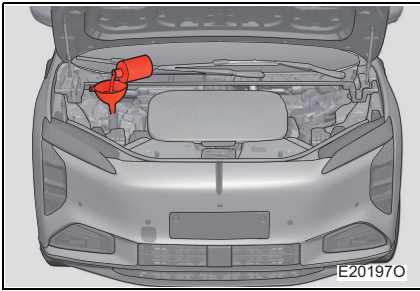

If any of the washers does not work or a warning message appears on the multi-function display of the instrument cluster, the washer fluid reservoir may be empty. In this case, add the washer fluid in time.

### WARNING

#### ■ Adding washer fluid

Do not add washer fluid when the power system is hot or operating. Otherwise, if the washer fluid is splashed on the motor, a fire may occur due to the alcohol in the washer fluid.



**CAUTION**

■ **Do not use any fluids other than the washer fluid**

Do not substitute soapy water or coolant for washer fluid, otherwise it may result in damage to the paintwork.

■ **Diluting washer fluid**

If necessary, dilute the washer fluid with water.

Refer to the freezing temperature indicated on the label of the washer fluid reservoir.

## 10-3. Maintenance by yourself

# 12 V battery

■ **12 V battery is located on the left side of the trunk.**

▶ **Lead-acid battery\***

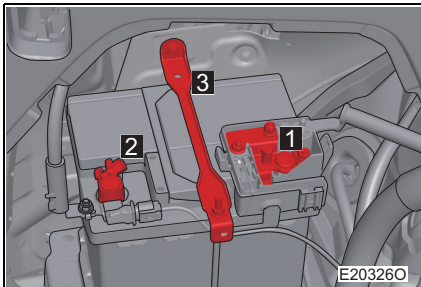

Make sure that there is no corrosion on battery terminals, no looseness in connections, no cracks in external parts, and no looseness in fixing clips.

- **1** Positive terminal
- **2** Negative terminal
- **3** Fixing clip

▶ **Lithium battery\***

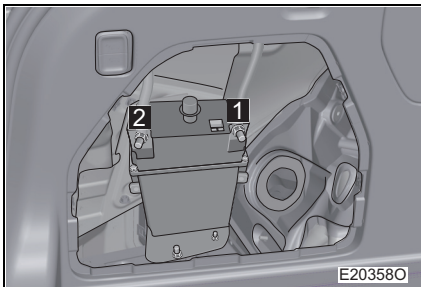

Make sure that there is no corrosion on battery terminals, no looseness in connections, no cracks in external parts, and no looseness in fixing clips.

- **1** Positive terminal
- **2** Negative terminal

### ■ **Precautions during installation**

- When connecting the battery, avoid connecting the terminal cables reversely, otherwise the electrical equipment in the vehicle may be damaged.
- During storage, handling and installation of the battery, prevent the positive and negative terminals from contacting with each other. For example, a metal wrench used for wiring can easily touch both the positive and negative terminals at the same time. In this case, the battery may be short-circuited, causing a direct failure.
- Due to the small vent holes in the battery, do not place it on its side or upside down during storage, handling and installation, to avoid leakage of electrolyte.
- Replace the battery with one of the same model as the original.
- If the wiring clips are oxidized or dirty when the battery is replaced, remove the oxide layer or dirt with sandpaper, and apply Vaseline to the wiring clips and battery terminals before connecting.

- During installation, connect the positive terminal and then the negative terminal, and during removal, disconnect the negative terminal and then the positive terminal, to avoid the risk of short circuit.

### ■ Precautions before charging

Pay attention to the following matters before charging:

- When charging the battery installed on the vehicle, be sure to turn off the vehicle power supply and disconnect the ground wire.
- When connecting or disconnecting the charger cable to/from the battery, make sure that the power switch on the charger is turned off.

### ■ Precautions during use

- Keep the battery's air outlet clean to avoid blockage.
- Charge the battery in the following conditions:
  - When the vehicle has not been used for a long time.
  - If the lamps are left on after parking.
  - If the doors are not securely closed during parking.
- If the vehicle is stored for more than 30 days, perform the following operations to maintain the normal charging state of the battery:
  - Disconnect the negative terminal ground wire of the battery to prevent battery discharge caused by additional current leakage.
  - Charge the battery every 20-45 days.

### Low voltage power management system\*

When vehicle power supply is set to OFF mode and 12 V lithium battery is too low, the battery management system can control the battery to disconnect external connections and maintain the basic power. At this time, press the charging port cover for more than 3 seconds to activate the battery. After activating the battery, it is necessary to start the vehicle within 1 minute to charge 12 V lithium battery, which can be used normally (only for 4WD models).

### Smart charging function\*

The vehicle has the smart charging function. When the vehicle is parked for a long time, the battery power is detected to be too low, and the battery can be charged by the power battery.

### Limited mode\*

When the vehicle power battery is less than 10%, in order to ensure that more electric energy is used for driving, some comfort functions of the vehicle will enter the limited mode, and relevant functions will be degraded or turned off until the power battery is charged to more than 10%. After function is limited, if comfort is affected, you can manually turn on or adjust limited functions such as boarding lighting, getting-off lighting, seat heating, seat ventilation, audio volume, etc.

In the event of a battery charging system fault in the vehicle, in order to conserve more electric energy for safe parking, the vehicle will enter a more severe limited mode, and the relevant functions will be degraded or turned off until the fault disappears. After function is limited, if comfort is affected, you can manually turn on or adjust limited functions such as ambient lamp, boarding lighting, getting-off lighting, seat heating, seat ventilation, steering wheel heating, exterior rearview mirror heating, rear windshield heating, screen brightness, audio volume, etc.

### Energy saving mode (low voltage load function)

The energy saving mode can be turned on and off through the driver assistance settings interface of the in-vehicle infotainment system. When it is turned on, a pop-up text prompt will appear and a secondary confirmation is required. (See P.188)

After the vehicle enters energy saving mode, some comfort functions will be turned off or degraded. If comfort is affected, you can turn on or adjust limited functions (such as seat heating, seat ventilation, screen brightness, audio volume, A/C mode, etc) individually through the switch of the corresponding function.

You can exit the energy saving mode by turning off the energy saving mode switch or setting the driving mode to non-economic mode.

The energy saving mode settings are not memorized, please manually turn on it when using the vehicle again if necessary.

**WARNING****■ Chemical substances in the battery**

The battery contains toxic corrosive sulfuric acid and may generate flammable and explosive hydrogen gas. To reduce the possibility of serious personal injury, be sure to observe the following precautions when handling the battery or working near it:

- Do not allow tools to contact battery terminals, so as to avoid sparks.
- Do not smoke or use open flames near the battery.
- Avoid splashing electrolyte into eyes and on skin or clothing.
- Do not inhale or swallow electrolyte.
- Wear goggles when working near the battery.
- Keep children away from the battery.

**■ Safe place for battery charging**

Charge the battery in an open place. Never charge it in a poorly ventilated garage or an enclosed place.

**■ Emergency measures for handling electrolyte**

- Accidental splashing of electrolyte into eyes  
Rinse your eyes with water for at least 15 minutes and seek medical attention immediately. If possible, continue to wash your eyes with a piece of absorbent sponge or cloth on the way to hospital.
- Splashing of electrolyte on skin  
Thoroughly wash the part on which electrolyte is splashed. If you have a burning sensation, seek medical attention immediately.
- Splashing of electrolyte on clothing  
Electrolyte may penetrate clothing and contact with the skin. Take off clothing promptly and adopt the above measures if necessary.
- Accidental swallowing of electrolyte  
Drink plenty of water or milk, take milk of magnesia, agitated raw eggs or vegetable oil, and seek medical attention immediately.



 **WARNING**

- **Do not disconnect the negative (-) terminal from the vehicle body side**
  - The disconnected negative (-) terminal may come into contact with the positive (+) terminal, resulting in a short circuit and serious injury or even death.
- **Parking for a long time may cause the battery loss, and the system will recharge it automatically. But it may not be able to recharge the battery automatically in the following situations:**
  - Battery sensor self-learning is not completed.
  - The system's static current is abnormal.
  - The front compartment cover is not closed.
  - Battery aging.
  - The power battery is low.
  - The high voltage system is faulty.

 **CAUTION**

- **Precautions for battery charging**

Do not charge the battery when the vehicle is started. Be sure to turn off all accessories.
- **Precautions for smart charging function**
  - The electricity for smart charging comes from the power battery, so entering the smart charging may reduce the power of the power battery, which is normal.
  - In order to avoid over discharging caused by smart charging, smart charging is not available when the power battery is low.
  - Confirm that front compartment cover is closed, otherwise the smart charging function is unavailable.

# Tire

**Replace the tire or perform tire rotation according to the wear condition of the tread.**

■ Tire inspection

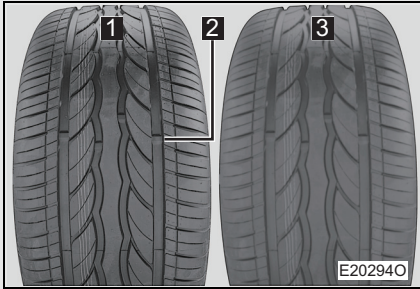

- 1** New tread
- 2** Tread wear indicator
- 3** Worn tread

If it wears down to the tread wear indicator surface, replace the tire (the picture is for reference only).

■ Tire rotation

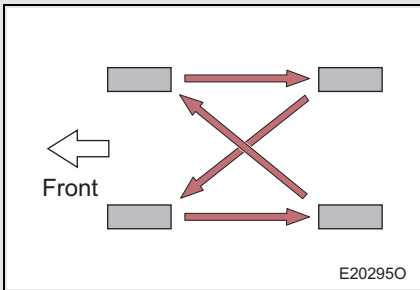

Perform tire rotation as shown in the figure.

It is recommended to perform tire rotation every 8,000~10,000 km to achieve even tire wear and extend the tire life.

**Note:**

Tire rotation is only available for models with the same tire type. After the tire rotation, it is necessary to configure the tire pressure monitoring system. Contact an authorized FAW Hongqi dealer if necessary.

---

**■ Measures for protection against wheel fault**

- When driving over curbs or similar obstacles, keep a slow speed in the vertical direction of the obstacles as much as possible.
- Be careful not to let the tires contact with grease and fuel.
- Regularly check the damage of tires (such as cuts, cracks or bulging), and remove debris embedded in the grooves of the tire pattern.

**■ Precautions for tire storage**

- Before removing the tire, mark its rolling direction, refit the tire and align it with the mark to maintain the rotation direction and the dynamic balance of the wheel.
- Store the removed wheels and tires in a cool and dry place, preferably in a dark place away from direct sunlight.

**■ Hidden damage**

- Damage to tires and rims often occurs in a hidden way, and abnormal vibration or deviation of the vehicle during driving may indicate a faulty wheel. In this case, drive the vehicle to an authorized FAW Hongqi dealer for inspection of wheels as soon as possible.

**■ When to replace the tire**

Replace the tire when:

- The tire has any defects such as cuts, fractures, cracks with exposed fabric ply or bulging.
- The tire leaks frequently or cannot be repaired due to other damage.

**■ Tire life**

Avoid using tires that have been in use for six years, and if you have to use them, drive at low speed with extreme caution.

**■ Winter tires**

- Winter tires or all-season tires can improve the driving and braking performance on winter roads. It is recommended to change to winter tires for the vehicle when the temperature is below 7 °C or on winter roads.
- If the tread of snow tires is worn by 4 mm or more, the anti-skid performance of snow tires will be significantly reduced.



## **WARNING**

### **■ Precautions for tire inspection or replacement**

To avoid transmission part damage which will affect the control performance of the vehicle, be sure to observe the following precautions:

- Do not use tires from different manufacturers, different models or with different tread patterns or tread wear degrees.
- Do not use tires that are not recommended by FAW.
- Do not mix tires with different structures such as radial, bias-belted and bias-ply tires.
- Do not mix summer, all-season and winter tires.
- Do not use tires that have been used on other vehicles.



## **CAUTION**

### **■ Driving on uneven roads**

When the vehicle is driven on soft or bumpy roads, extra care shall be taken. On such roads, tires are prone to bulging due to impacts, and they may be damaged eventually.

### **■ Decreased tire pressure during driving**

Do not continue driving, as this may result in complete tire and/or wheel damage.

# Tire pressure

**Be sure to maintain a proper tire pressure. Check the tire pressure at least once a month.**

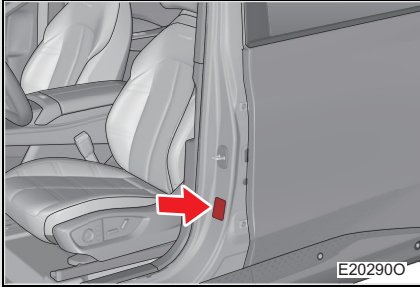

The tire pressure label is located under the B-pillar lock pin on the driver's side.

### ■ Consequences of incorrect tire pressure

Too low tire pressure:

- Increased rolling resistance leads to increased power consumption.
- The maneuverability and stability of the vehicle are reduced.
- Damage and high temperature may be caused, resulting in tire burst. When the tire pressure is seriously insufficient, the tire may be detached from the rim, reducing the safety.
- The tire is worn on both sides.

Too high tire pressure:

- The comfort of the vehicle is reduced.
- The middle of the tire is worn excessively.
- Over-inflation of the tire makes it prone to internal cracks and bursts when impacted.

### ■ Guidelines for tire pressure inspection

Even if your vehicle is equipped with a tire pressure monitoring system that can remind you of the tire pressure status in time, please check the tire pressure regularly.

When checking the tire pressure, please observe the following precautions:

- Check the tire only after it has cooled down.

If the vehicle has been parked for at least 3 hours, or has not driven for more than 1.5 km, carry out the inspection to obtain the accurate tire pressure reading.

- Always use a tire pressure gauge.

The tire appearance may sometimes be misleading. Additionally, the ride comfort and maneuverability may be reduced even if the tire pressure is slightly low.

- Do not deflate or depressurize the tire after driving. The tire pressure may increase after driving, which is normal.
- Do not overload the vehicle.

The weight of the driver, passengers and luggage should be evenly distributed to keep the vehicle balanced.



### WARNING

#### ■ Correct inflation is the key to tire protection

Be sure to maintain a proper tire pressure, otherwise the following conditions may occur:

- Excessive wear
- Uneven wear
- Poor maneuverability
- Tire burst after overheating
- Bead sealing performance degradation
- Wheel deformation or detachment of the tire from the wheel
- Potential tire damage due to poor road conditions

#### ■ Do not drive the vehicle with improper tire pressure

It is dangerous to drive the vehicle with improper tire pressure. An improper tire pressure may affect the maneuverability and result in an accident.



### CAUTION

#### ■ Precautions for inspection and adjustment of tire pressure

Be sure to reinstall the tire valve cap.

If the valve cap is not installed, dirt or moisture may enter the valve and cause air leakage, resulting in an accident.

If the valve cap is missing, install a new one as soon as possible.

# Wheel

**If the rim is bent, cracked or severely corroded, replace it. Otherwise, the tire may separate from the rim or you may lose control of the vehicle.**

### ■ Wheel selection

When replacing the wheel, ensure that the new wheel matches the original in bearing capacity, diameter, rim width and offset.

The wheel for replacement can be provided by an authorized FAW Hongqi dealer.

FAW recommends not to use the following types of wheels:

- Wheels of different sizes or types.
- Used wheels.
- Bent wheels that have been straightened.

### ■ Considerations for aluminum wheel

- Be sure to use the wheel bolts and wrench specially designed for the aluminum wheel.
- When performing tire rotation, maintenance or replacement, check and confirm the tightness of the wheel bolts.
- When tire chains are used, be careful not to damage the aluminum rim.
- Only use the balance weight or equivalent product specified by FAW to balance the wheel.



## WARNING

### ■ Replacing wheel

Do not use the wheel from a different model than the original one installed on the vehicle, otherwise you may lose control of the vehicle.

### ■ Installing wheel bolt

- Tighten the wheel bolt until the tapered portion comes into contact with the wheel bolt seat of the rim.

- Never apply oil or grease to wheel bolts.

Oil and grease may over-tighten the wheel bolts, resulting in damage to the bolt or spoke wheel. In addition, oil or grease may cause wheel bolts to get loose and cause the wheel to fall off, thus causing accidents, serious injury or even death. Please remove all oil or grease from wheel bolts.

### ■ Do not use defective wheels

Do not use cracked or deformed wheels.

Otherwise, tires may leak during driving, resulting in an accident.



## 10-3. Maintenance by yourself

### A/C filter

**Regularly replace the A/C filter to maintain the A/C efficiency.**

#### ■ Replacing A/C filter

**Step 1** Turn off the vehicle power supply.

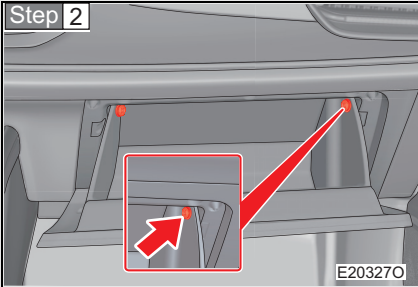

Open the glove box.

Remove the plastic fixing bolts on the left and right sides of the glove box, detach the limiter, and pull down the glove box to the position where the filter can be removed.

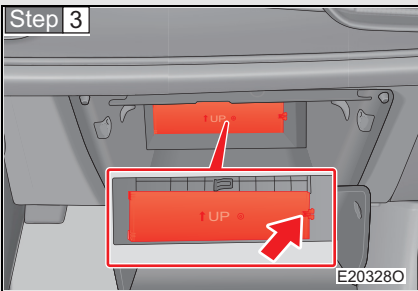

Remove the A/C filter cover and filter.

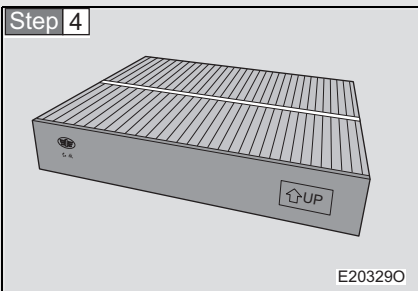

Replace with a new A/C filter of the same model.

The arrow mark on the filter should point upward.

---

■ **Replacement interval of A/C filter**

In dusty or heavy traffic areas, the replacement interval may need to be shortened.

■ **Significant reduction of airflow at air vent**

The filter may be blocked. Check the filter, and replace it if necessary.

■ **A/C filter**

If the filter needs to be cleaned or replaced, please contact an authorized FAW Hongqi dealer.



**CAUTION**

■ **Using A/C system**

Make sure that the filter is installed.

If the A/C system is used without a filter, it may be damaged.

■ **Removing filter cover**

Do not replace the A/C filter when the blower is working, otherwise personal injuries may be caused.

## 10-3. Maintenance by yourself

# Fragrance box\*

### ■ Replacing fragrance box

**Step 1** Turn off the vehicle power supply.

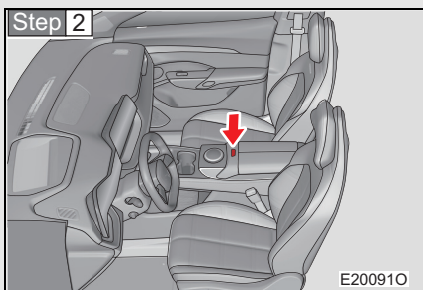

Open the center storage box and the fragrance box is located at the front side of glove box.

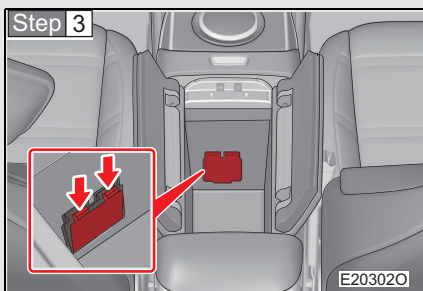

Open the fragrance box cover.

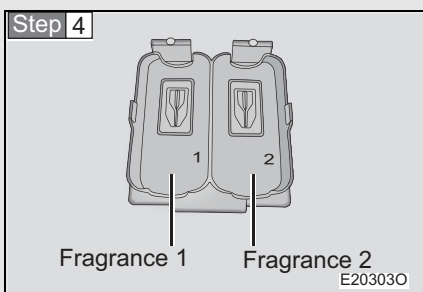

Remove the fragrance from fragrance box and replace it with a new one.

From left to right, place the fragrances in the following order: 1, 2.

## 10-3. Maintenance by yourself

# Replacing key battery

**If the battery power of the smart key is low, replace the battery with a new one.**

- The following part is required:
  - Lithium battery
- Replacing smart key battery

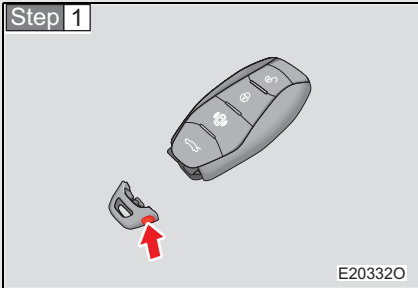

Press the unlock button to detach the key end cover.

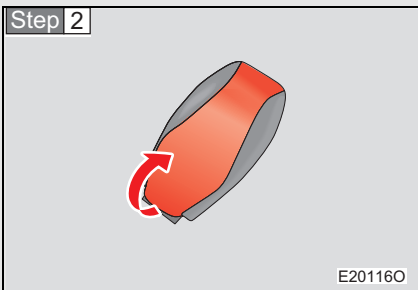

Detach the rear cover of the key.

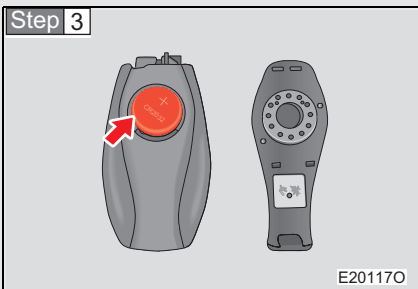

**1** Take out the old battery.

Insert a new battery with the + terminal facing downward.

**2** Reinstall the battery compartment into the smart key.

■ **If the battery power of the smart key is low, the following conditions may occur**

- Failure of wireless remote control function.
- Reduction of effective range.
- Failure of PEPS function.
- Failure of smart start function.

■ **Using CR2032 lithium battery**

- It is recommended to replace the battery with the same or equivalent product recommended by an authorized FAW Hongqi dealer.
- Always dispose of the old battery in accordance with the local laws and regulations.



**WARNING**

■ **Replaced battery and other parts**

Keep the parts out of reach of children.

These small parts may cause suffocation if swallowed by children.



**CAUTION**

■ **To ensure that the remote control key can work normally after the battery is replaced**

Be sure to observe the following precautions to avoid an accident.

- Always dry your hands before operating the smart key to prevent rusting of the battery.
- Do not touch or move any other parts inside the remote control key.
- Do not bend the battery terminals.
- During operation, avoid static electricity generated from your body, which may cause the malfunction of smart key.

## 10-3. Maintenance by yourself

# Checking and replacing fuse

**If any electrical component fails to work, a fuse may be blown. In this case, check and replace the fuse if necessary.**

**Step 1** Turn off the vehicle power supply.

**Step 2** The fuses are located in the following positions. Check the fuses as follows.

### ■ Front compartment

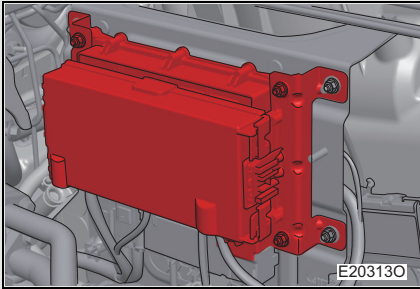

Press the fixing clip, and open the cover.

### ■ Trunk

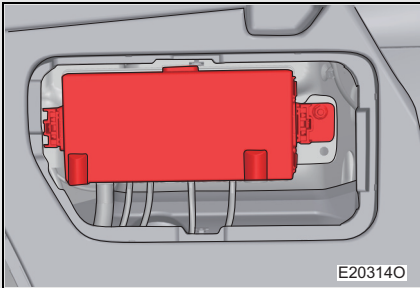

Press the fixing clip, and open the cover.

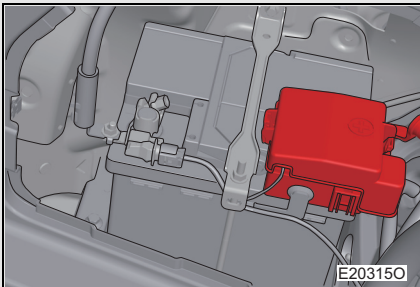

Press the fixing clip, and open the cover.

### ■ Distribution and amperage rating of fuses

For the distribution and amperage rating of fuses, please contact an authorized FAW Hongqi dealer for confirmation.

### ■ Precautions after fuse replacement

- If the electrical function still does not work after the fuse is replaced, further inspection may be required. Contact an authorized FAW Hongqi dealer.
- If the newly installed fuse blows again, contact an authorized FAW Hongqi dealer for inspection of the vehicle.

### ■ Circuit overloading

The fuse will blow, to prevent damage to the entire harness.



## WARNING

### ■ Preventing system fault or vehicle fire

Be sure to observe the following precautions, otherwise vehicle damage, fire or personal injury may be caused.

- Never use a fuse with an amperage rating higher or lower than specified.
- Always use the same or equivalent product recommended by an authorized FAW Hongqi dealer.  
Never replace the fuse with a wire, even temporary replacement is not allowed, otherwise serious damage to vehicle or even a fire may be caused.
- Do not modify the fuse or fuse box.



## CAUTION

### ■ Precautions before fuse replacement

Contact an authorized FAW Hongqi dealer to determine the cause of excessively high electrical load and have the vehicle repaired.

## 10-3. Maintenance by yourself

# Power battery

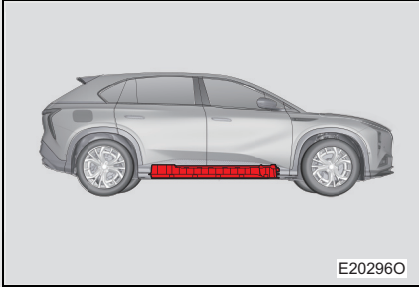

The power battery is located under the floor of vehicle.

- **Do not park the vehicle near high temperature heat source or fire source to avoid fire.**
- **Do not park the vehicle in damp or waterlogged area, to prevent the battery pack from being submerged in water for a long time to avoid fire.**
- **The vehicle should be parked in a dry, cool and well-ventilated location, and avoid prolonged exposure to direct sunlight as much as possible.**
- **The battery may also have a slow self discharge when not in use, resulting in a decrease in battery power (average 1% per week). A decrease to 0% can damage the battery. Therefore, if it is not used for a long time, please evaluate the battery's state of charge based on the estimated parking duration. Even if parking does not cause the battery power to reach 0%, it is still not recommended to park for a long time. Long standing can lead to a decrease in driving range. If the vehicle must be parked for a long time, it should be maintained monthly according to the following methods:**
  - Use appropriate methods (such as vehicle driving or high voltage components consumption) to discharge the battery until the instrument cluster prompts "Low power battery, please charge".
  - The power battery is fully charged.
  - If it is expected that the vehicle will be parked for more than 7 days, after the charging is completed, take proper measures (such as vehicle driving or high voltage components consumption) to discharge the power battery to 40%-60% and then continue to park the vehicle, which helps to extend the service life of the power battery.
  - If it is expected that the vehicle will be parked for more than 3 months, it is recommended to charge the power battery to 100% every 3 months. After the charging is completed, take proper measures (such as vehicle driving or high voltage components consumption) to discharge the power battery to



40%-60% and then continue to park the vehicle, otherwise it may cause the power battery life to be reduced or even damaged.

#### ■ Power battery recycling

Power battery is classified as hazardous industrial goods, and improper disposal will cause serious pollution to the environment. According to relevant national policies on power battery recycling, qualified recycling service centers are responsible for the recycling of power batteries. For information about recycling service centers, please consult an authorized FAW Hongqi dealer.

Do not sell, transfer, or privately remove, disassemble, modify power battery. When the power battery is no longer usable or needs to be recycled, the vehicle should be taken to the designated service center and the power battery should be removed from the vehicle according to the prescribed process to prevent safety accidents. According to relevant laws and regulations, if safety accidents or environmental pollution is caused due to the user's improper disposal of the used power battery, the user shall bear the responsibility.

 **WARNING**

- **If not recycled properly, the following situations may occur, causing certain personal injury:**
  - Illegal scrapping or disposal of power battery can cause harm to the environment, or people may suffer electric shock from touching high voltage parts.
  - Power battery is specifically designed for electric vehicle. If the power battery is used outside this vehicle or modified in any way, accidents such as electric shock, heat generation, smoking, explosion, and electrolyte leakage may occur.
  - When selling or transferring vehicle, the possibility of accidents is extremely high as the buyer does not understand these dangers.
- **When the battery leaks or there is a pungent and fragrant odor in the vehicle after a collision, or there is obvious liquid flowing out outside the vehicle, or there is smoke inside the battery pack:**
  - Please turn the vehicle power supply to OFF mode and disconnect the 12 V battery when conditions permit.
  - Immediately call the service hotline of authorized FAW Hongqi dealer for assistance, and do not perform any other operations on the vehicle.
- **The high voltage of power battery is very dangerous, it's strictly prohibited non-professional personnel from disassembling or repairing power battery.**
- **If the vehicle is scrapped without removing power battery, there is a risk of serious electric shock when touching high voltage parts, cables, and their connectors. If the vehicle must be scrapped, the power battery must be handled by an authorized FAW Hongqi dealer or professional organization. If the power battery is not handled properly, it may cause electric shock, which lead to serious injury or even death.**

 **CAUTION**

- **When using the vehicle for the first time or after parking for a long time, the battery power displayed on the instrument cluster may be inaccurate. It is recommended that the vehicle be fully charged first.**

 **CAUTION**

- There is a thermal management system inside the power battery assembly, but it is still recommended that users avoid intense driving in extreme high and low temperature environments as much as possible.
- The power battery should be stored in a dry and well-ventilated environment. The storage temperature range for the power battery (vehicle) is  $-40^{\circ}\text{C}\sim 60^{\circ}\text{C}$ . To ensure battery performance, it is not recommended to expose the vehicle to temperature below  $-30^{\circ}\text{C}$  or above  $60^{\circ}\text{C}$  for more than 24 hours. It is recommended to store the battery within the range of  $5^{\circ}\text{C}$  to  $30^{\circ}\text{C}$  if the storage time exceeds 1 week.
- Avoid placing the power battery to hot or humid environments (such as during paint baking) for a long time, and do not exceed 30 minutes at  $70^{\circ}\text{C}$  or 20 minutes at  $80^{\circ}\text{C}$ . It is recommended to remove the power battery assembly during paint baking.
- Try to avoid driving the vehicle in water that exceeds the height of chassis, otherwise it may cause permanent damage to the power battery assembly. After the vehicle has driven through water, it should be moved to a dry area for parking as soon as possible.
- Do not park the vehicle in a humid or waterlogged area, to avoid the power battery being submerged in water for a long time to avoid fire.
- It may cause damage to battery if the battery is not maintained for more than 6 months.
- To protect battery performance, it is not appropriate to discharge the battery to a very low level, otherwise it may cause permanent damage to battery performance.
- Do not park the vehicle near flammable and explosive items, various hazardous chemicals, high temperature heat source or fire source to avoid fire.
- Do not park the vehicle in conditions containing highly corrosive gas/liquid, so as to avoid damage to the battery structure and performance.
- When the capacity of power battery significantly decreases (the vehicle's driving range significantly decreases) or the power battery has a serious malfunction (the vehicle cannot run normally, or the instrument cluster indicates a power system malfunction), please contact an authorized FAW Hongqi dealer for inspection and maintenance of power battery, and replace the power battery assembly if necessary.

# Maintenance data

## Dimensions

■ Model: CA6490H0EVC, CA6490H0EVXC, CA6490H0EVB, CA6490H0EVXB

Overall length	4,925 mm
Overall width	1,950 mm
Overall height	1,680 mm 1,665 mm (air spring)
Front overhang	965 mm
Rear overhang	960 mm
Wheelbase	3,000 mm
Approach angle	18° (no load)/17° (no load) (air spring)
Departure angle	25° (no load)/24° (no load) (air spring)

■ Model: CA6490H0EVC, CA6490H0EVB

Wheel track	Front	19 inch: 1,672 (mm)
	Rear	19 inch: 1,673 (mm)

■ Model: CA6490H0EVXC, CA6490H0EVXB

Wheel track	Front	19 inch: 1,672 (mm) 21 inch: 1,667 (mm)
	Rear	19 inch: 1,673 (mm) 21 inch: 1,658 (mm)

## Seating capacity

■ Model: CA6490H0EVC, CA6490H0EVXC, CA6490H0EVB, CA6490H0EVXB

Seating capacity	5
------------------	---

## Drive mode

■ Model: CA6490H0EVC, CA6490H0EVB

Drive mode	Rear wheel drive
------------	------------------

■ Model: CA6490H0EVXC, CA6490H0EVXB

Drive mode	Four-wheel drive
------------	------------------

## Vehicle mass

■ Model: CA6490H0EVC

Curb weight		2,336 kg
Gross vehicle weight		2,786 kg
Axle load (full load)	Front	1,144 kg
	Rear	1,642 kg

■ Model: CA6490H0EVXC

Curb weight		2,461 kg
Gross vehicle weight		2,911 kg
Axle load (full load)	Front	1,258 kg
	Rear	1,653 kg

■ Model: CA6490H0EVB

Curb weight		2,350 kg
Gross vehicle weight		2,800 kg
Axle load (full load)	Front	1,150 kg
	Rear	1,650 kg

■ Model: CA6490H0EVXB

Curb weight		2,475 kg
Gross vehicle weight		2,925 kg
Axle load (full load)	Front	1,264 kg
	Rear	1,661 kg

Power performance of the vehicle

■ Model: CA6490H0EVC, CA6490H0EVXC, CA6490H0EVB, CA6490H0EVXB

Maximum gradeability	45% (CA6490H0EVXC, CA6490H0EVXB) 35% (CA6490H0EVC, CA6490H0EVB)
Maximum speed	200 km/h

Motor

Model	CAM220PT8
Motor type	AC permanent magnet synchronous motor
Peak power	253 kW
Rated power	80 kW
Peak speed	22,000 rpm
Rated speed	6,367 rpm
Peak torque	450 N·m
Rated torque	120 N·m

Model	CAM190PT2
Motor type	AC permanent magnet synchronous motor
Peak power	202 kW
Rated power	70 kW
Peak speed	18,000 rpm
Rated speed	6,080 rpm
Peak torque	306 N·m
Rated torque	110 N·m
Model	CAM220PT17
Motor type	AC permanent magnet synchronous motor
Peak power	253 kW
Rated power	80 kW
Peak speed	22,500 rpm
Rated speed	6,367 rpm
Peak torque	450 N·m
Rated torque	120 N·m

<b>Power battery</b>
----------------------

■ Model: CA6490H0EVC
----------------------

Model	CAB207EL1
Battery type	Lithium iron phosphate battery
Nominal voltage	412 V
Total energy	85 kWh
Weight	605 kg
Cooling method	Liquid cooling
Operation temperature	-30 ~ 55°C (discharging)    -20 ~ 55°C (charging)

■ Model: CA6490H0EVXC
-----------------------

Model	CAB207EL2
Battery type	Lithium iron phosphate battery
Nominal voltage	412 V
Total energy	85 kWh
Weight	605 kg
Cooling method	Liquid cooling
Operation temperature	-30 ~ 55°C (discharging)    -20 ~ 55°C (charging)



## ■ Model: CA6490H0EVB

Model	CAB266EL1
Battery type	Ternary lithium battery
Nominal voltage	419 V
Total energy	111 kWh
Weight	616 kg
Cooling method	Liquid cooling
Operation temperature	-30 ~ 55°C (discharging)    -20 ~ 55°C (charging)

## ■ Model: CA6490H0EVXB

Model	CAB266EL2
Battery type	Ternary lithium battery
Nominal voltage	419 V
Total energy	111 kWh
Weight	616 Kg
Cooling method	Liquid cooling
Operation temperature	-30 ~ 55°C (discharging)    -20 ~ 55°C (charging)

## Front wheel alignment (no load)

## ■ Model: CA6490H0EVC

Front wheel camber	-23'±30'
Kingpin caster angle	6°13'±45'
Kingpin inclination angle	6°44'±45'
Front wheel toe-in	$\beta=12'\pm 5'$ $2\beta=24'\pm 10'$

## ■ Model: CA6490H0EVXC

Front wheel camber	$-24' \pm 30'$
Kingpin caster angle	$6^{\circ}10' \pm 45'$
Kingpin inclination angle	$6^{\circ}47' \pm 45'$
Front wheel toe-in	$\beta = 11' \pm 5'$ $2\beta = 22' \pm 10'$

## ■ Model: CA6490H0EVB

Front wheel camber	$-24' \pm 30'$
Kingpin caster angle	$6^{\circ}13' \pm 45'$
Kingpin inclination angle	$6^{\circ}44' \pm 45'$
Front wheel toe-in	$\beta = 12' \pm 5'$ $2\beta = 24' \pm 10'$

## ■ Model: CA6490H0EVXB

Front wheel camber	$-26.8' \pm 30'$
Kingpin caster angle	$6^{\circ}10' \pm 45'$
Kingpin inclination angle	$6^{\circ}47' \pm 45'$
Front wheel toe-in	$\beta = 11' \pm 5'$ $2\beta = 22' \pm 10'$

## Rear wheel alignment (no load)

## ■ Model: CA6490H0EVC, CA6490H0EVXC, CA6490H0EVB, CA6490H0EVXB

Rear wheel camber	$-1^{\circ}16' \pm 30'$
Rear wheel toe-in	$\beta = 7.5' \pm 5'$ $2\beta = 15' \pm 10'$

## Suspension

### Model: CA6490H0EVC

Front suspension	Type		Double wishbone independent suspension
	Type of spring		Spiral spring
	Type of shock absorber		General gas-filled shock absorber
	Stabilizer bar	Type	Hollow stabilizer bar
Diameter		$\phi 32.5 \times 6$ mm	
Rear suspension	Type		5-link independent suspension
	Type of spring		Spiral spring
	Type of shock absorber		General gas-filled shock absorber
	Stabilizer bar	Type	Hollow stabilizer bar
Diameter		$\phi 27.7 \times 3.5$ mm	

### Model: CA6490H0EVXC

Front suspension	Type		Double wishbone independent suspension
	Type of spring		Spiral spring
	Type of shock absorber		General gas-filled shock absorber/ CDC shock absorber
	Stabilizer bar	Type	Hollow stabilizer bar
Diameter		$\phi 32.5 \times 6$ mm	

Rear suspension	Type		5-link independent suspension
	Type of spring		Spiral spring
	Type of shock absorber		General gas-filled shock absorber/ CDC shock absorber
	Stabilizer bar	Type	Hollow stabilizer bar
Diameter		$\varnothing 27.7 \times 3.5$ mm	

■ Model: CA6490H0EVB

Front suspension	Type		Double wishbone independent suspension
	Type of spring		Spiral spring
	Type of shock absorber		CDC shock absorber
	Stabilizer bar	Type	Hollow stabilizer bar
Diameter		$\varnothing 32.5 \times 6$ mm	
Rear suspension	Type		5-link independent suspension
	Type of spring		Spiral spring
	Type of shock absorber		CDC shock absorber
	Stabilizer bar	Type	Hollow stabilizer bar
Diameter		$\varnothing 29.3 \times 3.7$ mm	

■ Model: CA6490H0EVXB

Front suspension	Type		Double wishbone independent suspension
	Type of spring		Spiral spring/air spring
	Type of shock absorber		CDC shock absorber
	Stabilizer bar	Type	Hollow stabilizer bar
Diameter		$\phi 32.5 \times 6 \text{ mm}$	
Rear suspension	Type		5-link independent suspension
	Type of spring		Spiral spring/air spring
	Type of shock absorber		CDC shock absorber
	Stabilizer bar	Type	Hollow stabilizer bar
Diameter		$\phi 29.3 \times 3.7 \text{ mm}$	

## Vehicle identification

■ Manufacturer's nameplate

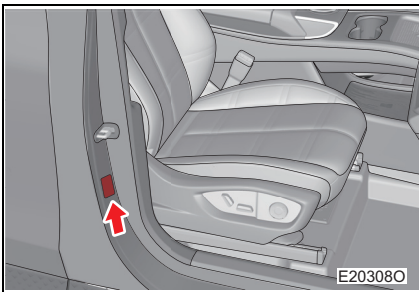

As shown in the figure, the manufacturer's nameplate is located on the right B-pillar.

■ Vehicle identification number

The vehicle identification number (VIN) is the legal identification of the vehicle. As the primary identification number, the VIN is used for owner registration.

▶ Top left of the instrument panel

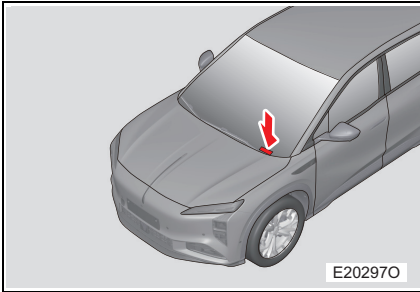

It is affixed under the windshield at the top left of the instrument panel.

▶ Under the front passenger's seat

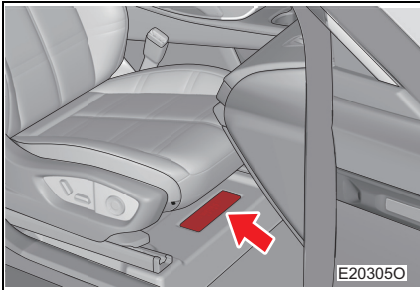

It is imprinted under the front passenger's seat.

■ Motor No. (CAM190PT2)

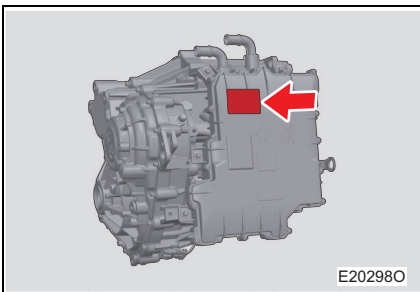

As shown in the figure, the motor number and motor nameplate are located on the motor body.

■ Motor No. (CAM220PT8, CAM220PT17)

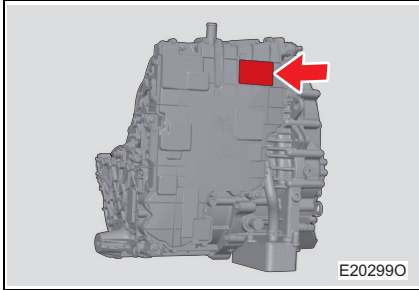

As shown in the figure, the motor number and motor nameplate are located on the motor body.

■ Power battery No. (CAB266EL1, CAB266EL2)

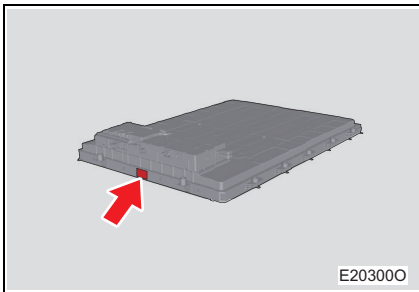

As shown in the figure, the battery number and battery nameplate are located on the battery housing.

■ Power battery No. (CAB207EL1, CAB207EL2)

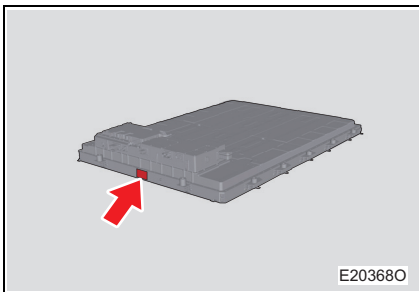

As shown in the figure, the battery number and battery nameplate are located on the battery housing.

### Microwave window

- Model: CA6490H0EVC, CA6490H0EVXC, CA6490H0EVB, CA6490H0EVXB

Recommended position for microwave window (viewed in the cab)

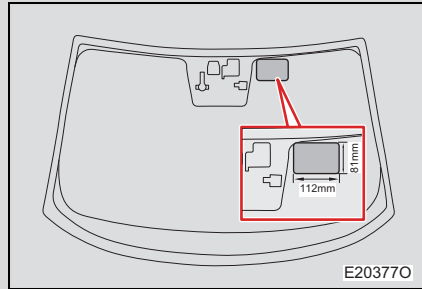

### Cooling system

- Model: CA6490H0EVC, CA6490H0EVB

Coolant capacity	14.75 L
------------------	---------

Coolant type	Use the automobile long-life coolant throughout the year (G30-91)
--------------	---

- Model: CA6490H0EVXC, CA6490H0EVXB

Coolant capacity	15.75 L
------------------	---------

Coolant type	Use the automobile long-life coolant throughout the year (G30-91)
--------------	---

### Reducer (front/rear)

- Model: CA6490H0EVC, CA6490H0EVB, CA6490H0EVXC, CA6490H0EVXB

Reducer oil capacity (initial filling volume)	1.125 ± 0.075 L / 2.55 ± 0.5 L (front/rear)
---	---

Reducer oil type	FUCHS BluEV EG DHTF 3932
------------------	--------------------------



Note: For rear reducer, it is required to fill an additional 0.2 L of oil if pressure filter is replaced.

### Electrical system

■ Model: CA6490H0EVC, CA6490H0EVB, CA6490H0EVXC

12 V battery	50 Ah maintenance free battery
--------------	--------------------------------

■ Model: CA6490H0EVXB

12 V battery	20 Ah lithium battery
--------------	-----------------------

### A/C refrigerant

A/C refrigerant capacity	1100 ± 15 g
--------------------------	-------------

A/C refrigerant specification	R134a
-------------------------------	-------

### Brake

Free travel of brake pedal	≤ 12 mm
----------------------------	---------

Travel of brake pedal	172 mm
-----------------------	--------

Brake fluid capacity	0.86 ± 0.01 L
----------------------	---------------

Brake fluid type (In accordance with GB 12981-2012)	DOT4
--	------

<b>Reasonable usable range of brake lining pairs</b>
--

■ Model: CA6490H0EVC

► Front

Thickness of brake pad	Standard	Total 18.8 mm	Thickness of friction material 11.5 mm
	Minimum	Total 9.3 mm	Thickness of friction material 2 mm
Thickness of brake disc	Standard	30 mm	
	Minimum	28 mm	

► Rear

Thickness of brake pad	Standard	Total 17.5 mm	Thickness of friction material 11 mm
	Minimum	Total 8.5 mm	Thickness of friction material 2 mm
Thickness of brake disc	Standard	24 mm	
	Minimum	22 mm	

■ Model: CA6490H0EVB, CA6490H0EVXB, CA6490H0EVXC

► Front

Thickness of brake pad	Standard	Total 17.8 mm	Thickness of friction material 10.5 mm
	Minimum	Total 9.5 mm	Thickness of friction material 2.5 mm
Thickness of brake disc	Standard	32 mm	
	Minimum	30 mm	

► Rear

Thickness of brake pad	Standard	Total 17.5 mm	Thickness of friction material 11 mm
	Minimum	Total 8.5 mm	Thickness of friction material 2 mm
Thickness of brake disc	Standard	24 mm	
	Minimum	22 mm	

 **CAUTION**

When the brake pad is worn to the minimum thickness, there will be an audible alarm prompt, and the brake pad should be replaced as soon as possible.

## Tires and wheels

■ Model: CA6490H0EVC, CA6490H0EVXC, CA6490H0EVB, CA6490H0EVXB

Tire specifications	255/45 R21 (front) 275/40 R21 (rear)			
Wheel dimensions	8.5J × 21 (front)		9J × 21 (rear)	
Tire pressure kPa (bar)		3 persons	ECO	Full load
	Front	230 (2.3)	270 (2.7)	250 (2.5)
	Rear	250 (2.5)	270 (2.7)	270 (2.7)
Wheel bolt torque	160 ± 10 N·m			
Requirements for wheel dynamic balance	Residual unbalance: ≤ 8 g			

## Seat (when the seat cushion is deep)

■ Model: CA7001H0EVC, CA7001H0EVXC, CA7001H0EV, CA7001H0EVX

Front seat	Longitudinal position (forward from the limit position at the rear end of the slide rail)	254 mm
	Seat back reclining	25°
Rear seat	Longitudinal adjustment	Not adjustable
	Seat back reclining	25°

Normal use state of the seat back: The seat back in any position within the range of adjustable travel is in normal use state.

Other information



---

**List of abbreviations .....436**  
**Privacy notice .....439**  
**Event data recorder .....440**

List of abbreviations  
 List of abbreviations

Abbreviation	Description
ABP	Automatic Brake Prefill
ABS	Antilock Brake System
ACC	Adaptive Cruise Control
ADB	Adaptive Driving Beam
ADS	Auto Defrost System
AEB	Autonomous Emergency Braking
APA	Auto Parking Assist
AQS	Air Quality System
AVP	Automated Valet Parking
BSD	Blind Spot Detection
CDC	Continuous Damping Control
CDD-S	Controlled Deceleration for ACC-Stop & Go
CDP	Controlled Deceleration for Parking Brake
DCLC	Driver Controlled Lane Change
DSM	Driver Status Monitoring
EBD	Electronic Brakeforce Distribution
EDR	Event Data Recorder
ELR	Emergency Locking Retractor
ESA	Emergency Steering Assist
EPB	Electrical Parking Brake

Abbreviation	Description
EPS	Electric Power Steering
ESC	Electronic Stability Control
ESS	Emergency Stop Signal
FCW	Forward Collision Warning
GPS	Global Positioning System
HBA	Hydraulic Brake Assist
HBB	Hydraulic Brake Boost
HCU	Hybrid Control Unit
HDC	Hill Descent Control
HHC	Hill Hold Control
LDW	Lane Departure Warning
LED	Light Emitting Diode
LKA	Lane Keeping Assist
MAX	Maximum
MIN	Minimize
OBD	On-Board Diagnostic
POI	Point Of Interest
PTC	Positive Temperature Coefficient
SACC	Super Adaptive Cruise Control
SOC	State Of Charge

Abbreviation	Description
TCS	Traction Control System
TPMS	Tire Pressure Monitoring System
TSR	Traffic Sign Recognition
USB	Universal Serial Bus
VDC	Vehicle Domain Center
VIN	Vehicle Identification Number



**We are well aware of the importance of personal information to you, will comply with the requirements of national laws and regulations related to personal information, and will take corresponding security protection measures to protect your personal information in accordance with the industry's mature security standards, please read and understand the Privacy Policy carefully before using our products (or services).**

### Access to privacy policy

- Method 1: Acquisition path of head unit in-vehicle infotainment system:  
Multimedia display→System setting/login interface<sup>\*1</sup>→Privacy agreement
- Method 2: Acquisition path of Hongqi Zhilian APP:  
Hongqi Zhilian APP→Login interface→Privacy policy
- Method 3: Acquisition path from the Hongqi official website:  
FAW Group Hongqi official website→Service support→Privacy policy

<sup>\*1</sup>: The path to view the privacy policy varies slightly depending on the version of head unit.

### ■ Contact us

If you have any questions, comments or suggestions about the Privacy Policy, please contact us as follows:

Company name	China FAW Group Co., Ltd
Address	No. 1, Xinhongqi Street, Automobile Economic and Technological Development Zone, Changchun, Jilin
Customer hotline	400-817-1717

# Event data recorder

## Event data recorder

The vehicle is equipped with an event data recorder (EDR). The EDR is mainly designed to record data in the event of certain or sudden collisions (such as airbag deployment or collision with a barrier), so as to help understand the operation of the vehicle's system. The EDR is specially used to record data related to the dynamic control and safety systems of the vehicle within a short period of time. However, the recorded threshold value may not be triggered, depending on the severity and type of collision.

The data content, source and use recorded by the EDR of the vehicle are shown in the table below:

No.	Data name	Content	Source
1	Longitudinal delta-V	Change in longitudinal vehicle speed	Airbag control unit
2	Maximum recorded longitudinal delta-V	Maximum cumulative vehicle speed change in the X-axis direction recorded by the EDR	Airbag control unit
3	Time to reach the maximum recorded longitudinal delta-V	Time recorded by the EDR from time zero to occurrence of the maximum cumulative vehicle speed change along the X-axis	Airbag control unit
4	Clipping flag	Point in time when the EDR first reaches the sensor range when collecting the acceleration (horizontal or longitudinal)	Airbag control unit
5	Vehicle speed	Wheel-side linear velocity or the vehicle speed obtained by other means	Integrated brake controller
6	Service brake, on or off	Used to detect if the driver depresses the brake pedal	Integrated brake controller
7	Driver's seat belt status	Status of the driver's seat belt buckle switch	Airbag control unit

No.	Data name	Content	Source
8	Accelerator pedal position	Percentage of the accelerator pedal actual position to the driver's fully depressed position	Vehicle controller
9	Power-on cycle during event	Number of power cycles from the first use of the ECU that records the EDR data to the ECU that records the EDR data when the event occurs	Airbag control unit
10	Power-on cycle during reading	Number of power cycles from the first use of the ECU that records the EDR data to the ECU that records the EDR data during reading	Airbag control unit
11	Event data record complete status	Status flag indicating whether the event data is completely recorded and stored in the ECU that records the EDR data	Airbag control unit
12	Time interval between this event and the last event	Elapsed time from the start of event X to the start of event X-1 if the two events occur within 5 seconds	Airbag control unit
13	Vehicle identification number	Vehicle identification number (VIN) assigned by the vehicle manufacturer	Airbag control unit
14	Hardware number of ECU that records EDR data	ECU that realizes the EDR recording function of the vehicle	Airbag control unit
15	Serial number of ECU that records EDR data	ECU that realizes the EDR recording function of the vehicle	Airbag control unit
16	Software number of ECU that records EDR data	ECU that realizes the EDR recording function of the vehicle	Airbag control unit
17	Longitudinal acceleration $a$	The component of vector acceleration at a certain point on the vehicle in the X-axis direction	Airbag control unit
18	Lateral acceleration	The component of vector acceleration at a certain point on the vehicle in the Y-axis direction	Airbag control unit

No.	Data name	Content	Source
19	Lateral delta-V	Changes in lateral speed of vehicle. The lateral delta-V is only the component of the total delta-V in the Y-axis direction	Airbag control unit
20	Maximum recorded lateral delta-Vb	Maximum cumulative vehicle speed change in the Y-axis direction recorded by the EDR, this data should be used in conjunction with the "Time to reach the maximum recorded lateral delta-V"	Airbag control unit
21	Square b of the maximum recorded resultant delta-V	The maximum value of sum-of-squares of longitudinal delta-V and lateral delta-V recorded by the EDR	Airbag control unit
22	Time b to reach the maximum recorded lateral delta-V	Time recorded by the EDR from time zero to occurrence of the maximum cumulative vehicle speed change along the Y-axis, this data should be used in conjunction with the "Maximum recorded lateral delta-V"	Airbag control unit
23	Time to reach the square of the maximum recorded resultant delta-V	Time from time zero to occurrence of the square of the maximum recorded resultant delta-V, this data should be used in conjunction with the "Square of the maximum recorded resultant delta-V"	Airbag control unit
24	Yaw velocity	Changes in vehicle angle relative to the Z-axis before and during the event, clockwise is positive, applicable to vehicles equipped with electronic stability control system	Airbag control unit

No.	Data name	Content	Source
25	Steering angle	The angular coordinate of the steering wheel, where zero (0°) indicates that the steering wheel is in the middle position (during straight-line driving), and a positive value indicates that the steering wheel is turned counterclockwise (to the left), applicable to vehicles equipped with steering angle sensor	Power steering controller
26	T end	The end of the collision event, if the condition has not been met until the end of the recording period, T end can be defined as the moment of the last recorded data point	Intelligent domain controller
27	Year	Year of the event occurred	Intelligent domain controller
28	Month	Month of the event occurred	Intelligent domain controller
29	Day	Date of the event occurred	Intelligent domain controller
30	Hour	Time on the day of the event occurred (hour)	Intelligent domain controller
31	Minute	Time on the day of the event occurred (minute)	Intelligent domain controller
32	Second	Time on the day of the event occurred (second)	Intelligent domain controller
33	Gear	Actual gear	Vehicle controller

No.	Data name	Content	Source
34	Brake pedal position	Actual position of brake pedal, namely range from not depressed to fully depressed It can be stated in the EDR reading report. When the brake pedal position is less than 100%, the brake system may achieve 100% braking. This is applicable to vehicles equipped with brake pedal position sensor	Integrated brake controller
35	Parking system status	It is used to detect whether the parking brake is activated	Area control unit
36	Turn signal switch status	It is used to indicate the intention of vehicle to make turn or change lanes	Central computing unit
37	Driver seat belt pretensioner deployment time	The time elapsed from the start of the event (T0) to the driver seat belt pretensioner deployment command	Airbag control unit
38	Driver frontal airbag deployment time (first stage)	The time elapsed from the start of the event (T0) to the first stage of the driver frontal airbag deployment command	Airbag control unit
39	Driver side airbag deployment time	The time elapsed from the start of the event (T0) to the driver side airbag deployment command	Airbag control unit
40	Driver side curtain airbag deployment time	The time elapsed from the start of the event (T0) to the driver side curtain airbag deployment command	Airbag control unit
41	Front passenger seat belt status	The status of front passenger seat belt buckle switch, applicable to vehicles equipped with seat belt reminder	Airbag control unit
42	Front passenger seat belt pretensioner deployment time	The time elapsed from the start of the event (T0) to the front passenger seat belt pretensioner deployment command	Airbag control unit

No.	Data name	Content	Source
43	Front passenger frontal airbag suppression status	The suppression status displayed by the front passenger frontal airbag, applicable to vehicles equipped with frontal airbag suppression switch	Airbag control unit
44	Front passenger frontal airbag deployment time (first stage)	The time elapsed from the start of the event (T0) to the first stage of the front passenger frontal airbag deployment command	Airbag control unit
45	Front passenger side airbag deployment time	The time elapsed from the start of the event (T0) to the front passenger side airbag deployment command	Airbag control unit
46	Front passenger side curtain airbag deployment time	The time elapsed from the start of the event (time zero) to the front passenger side curtain airbag deployment command	Airbag control unit
47	Occupant protection system alarm status	Occupant protection system fault status	Airbag control unit
48	Tire pressure monitoring system alarm status	Alarm status when the on-board tire pressure monitoring system detects low pressure of one or more tires	Central computing unit
49	Brake system alarm status	Brake system fault status	Central computing unit
50	Cruise control system status	Operation status of cruise control system	Central computing unit
51	Adaptive cruise control system status	Operation status of adaptive cruise control system	Central computing unit
52	Anti-lock brake system status	Operation status of anti-lock brake system	Integrated brake controller
53	Automatic emergency braking system status	Operation status of automatic emergency braking system	Central computing unit

No.	Data name	Content	Source
54	Electronic stability control system status	Operation status of electronic stability control system	Integrated brake controller
55	Traction control system status	Operation status of traction control system	Integrated brake controller
56	Pre-event synchronization timing time	The relative time from the last data sampling point before T0 to T0, applicable to vehicles equipped with pre-event synchronization timing function. It is used for time alignment of different data	Airbag control unit

These data can help to better understand the situation of collision and personal injury caused therefrom.

Note: The EDR will record data only when a collision of certain degree occurs to the vehicle; that is to say, the EDR will not record data and personal information (e.g. name, gender, age and site of collision) during normal driving. Locked events can override unlocked events rather than locked events. To read the data recorded by the EDR, it is required to use the special equipment specified by the vehicle manufacturer and obtain the permission of access to the EDR. Besides the vehicle manufacturer, the third parties with special equipment (such as law enforcement agencies) can also read the information if they have the permission of access to the vehicle or EDR.

For the introduction on ESC/ABS/ACC and other functions, refer to the relevant chapters in this manual.

Based on legal obligations regarding product monitoring, our company can use the data for environmental monitoring, research and vehicle safety system quality improvement. For the purpose of research, our company can provide the data for relevant parties in an anonymous form, that is, the data does not include information about the vehicle, owner, or lessee.



## References for charging station

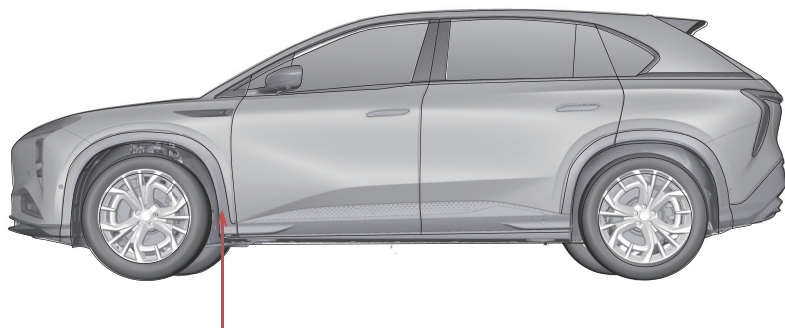

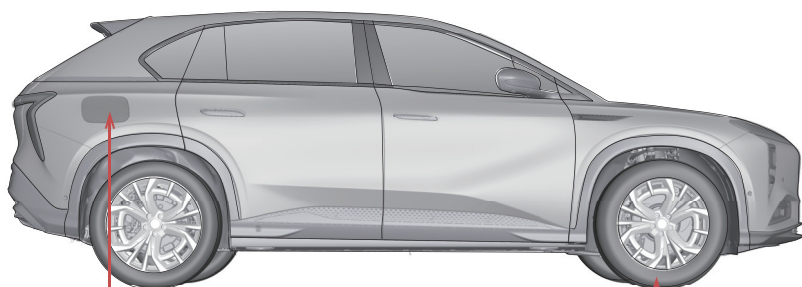

Front compartment cover release handle  
P.388



Charging port cover  
P.78

Tire pressure  
P.434

### List of accompanying tools

Illustration	Name	Quantity
 A rectangular warning triangle with a reflective surface and a small rectangular tab on the right side.	Warning triangle	1
 A metal towing eye with a circular hook at one end and a cylindrical shaft at the other.	Towing eye	1
 A small, rectangular tire repair kit with a handle on top.	Tire repair kit	1