

ROBOTICS

Product manual

CRB 15000



Trace back information:
Workspace Main version a525
Checked in 2023-06-30
Skribenta version 5.5.019

Product manual

CRB 15000

OmniCore

Document ID: 3HAC077389-001

Revision: L

The information in this manual is subject to change without notice and should not be construed as a commitment by ABB. ABB assumes no responsibility for any errors that may appear in this manual.

Except as may be expressly stated anywhere in this manual, nothing herein shall be construed as any kind of guarantee or warranty by ABB for losses, damage to persons or property, fitness for a specific purpose or the like.

In no event shall ABB be liable for incidental or consequential damages arising from use of this manual and products described herein.

This manual and parts thereof must not be reproduced or copied without ABB's written permission.

Keep for future reference.

Additional copies of this manual may be obtained from ABB.

Original instructions.

© Copyright 2021 - 2023 ABB. All rights reserved.
Specifications subject to change without notice.

Table of contents

Overview of this manual	9
Product documentation	13
How to read the product manual	15
1 Safety	17
1.1 Safety information	17
1.1.1 Limitation of liability	17
1.1.2 Requirements on personnel	19
1.2 Safety signals and symbols	20
1.2.1 Safety signals in the manual	20
1.2.2 Safety symbols on manipulator labels	22
1.3 Robot stopping functions	28
1.4 Safety during installation and commissioning	29
1.5 Safety during operation	31
1.6 Safety during maintenance and repair	33
1.6.1 Safety during maintenance and repair	33
1.6.2 Emergency release of the robot axes	34
1.6.3 Brake testing	35
1.7 Safety during troubleshooting	36
1.8 Safety during decommissioning	37
2 Manipulator description	39
2.1 About CRB 15000	39
2.2 Technical data	40
2.3 Safety data	45
2.4 Working range	47
2.5 The unit is sensitive to ESD	53
3 Installation and commissioning	55
3.1 Introduction to installation and commissioning	55
3.2 Unpacking	56
3.2.1 Pre-installation procedure	56
3.2.2 Risk of tipping/stability	57
3.3 On-site installation	60
3.3.1 Brief installation procedure	60
3.3.2 Lifting the robot	61
3.3.2.1 Orienting and securing the robot	61
3.3.3 Manually releasing the brakes	69
3.3.4 Manually releasing the brakes with the external tool	71
3.3.5 Installation of brake release tool	75
3.3.6 Setting the system parameters for an inverted or a tilted robot	77
3.3.7 Loads fitted to the robot, stopping time and braking distances	80
3.3.8 Fitting equipment on the robot (robot dimensions)	81
3.3.9 Test run after installation, maintenance, or repair	90
3.3.10 Installation of laser scanner	91
3.4 Electrical connections	99
3.4.1 Robot cabling and connection points	99
3.4.2 Customer connections on the manipulator	101
3.5 Arm-side interface	105
3.5.1 Configuring the arm-side interface	105
3.5.2 Using the arm-side interface	109
3.5.3 Testing the FlexPendant connection	110
3.5.4 Working closely with the robot in a safe way	111
3.6 Configuring the software	114
3.6.1 Information about software for the CRB 15000	114
3.6.2 Lead-through	117

Table of contents

3.6.3	The SafeMove configurator app on FlexPendant	120
3.6.4	Guidelines for transient and quasi-static contact, CRB 15000	132
3.6.5	Configuration of SafeMove using Visual SafeMove in RobotStudio	135
3.6.6	Information about Collaborative Speed Control add-in	141
3.6.7	Speed control	142
3.6.7.1	Configuration of one PROFINET-base laser scanner (RobotWare 7.5 or earlier)	142
3.6.7.2	Configuration of one PROFIsafe-based laser scanner (RobotWare 7.6 or later and PLC acting as Master)	148
3.6.7.3	Configuration of two PROFIsafe-based laser scanners (RobotWare 7.6 or later and PLC acting as Master)	152
3.6.7.4	Configuration of one PROFIsafe-based laser scanner (RobotWare 7.10 or later and OmniCore acting as Master)	156
3.6.7.5	Configuration of two PROFIsafe-based laser scanners (RobotWare 7.10 or later and OmniCore acting as Master)	160
3.6.7.6	Configuration of one SafetyIO-base laser scanner (RobotWare 7.6 or later)	164
3.6.7.7	Configuration of two SafetyIO-base laser scanners (RobotWare 7.6 or later)	169
3.6.7.8	Speed control strategies	174
3.6.8	Use cases of safety configurations	177
4	Maintenance	183
4.1	Introduction	183
4.2	Maintenance schedule and expected component life	184
4.2.1	Specification of maintenance intervals	184
4.2.2	Maintenance schedule	185
4.3	Inspection activities	186
4.3.1	Inspecting the robot	186
4.3.2	Inspecting the cable harness	190
4.4	Cleaning activities	195
4.4.1	Cleaning the CRB 15000	195
4.5	Testing activities	196
4.5.1	Testing the brake release functionality	196
4.5.2	Running the Cyclic Brake Check routine	198
4.5.3	Testing the functionality of the joint electronics	199
5	Repair	201
5.1	Introduction	201
5.2	General procedures	202
5.2.1	Mounting instructions for sealings	202
5.3	Cable harness	205
5.3.1	Replacing the base cabling	205
5.3.2	Replacing the axis-1 cabling	221
5.3.3	Replacing the axis-2 cabling	293
5.3.4	Replacing the axis-3 cabling	347
5.3.5	Replacing the axis-4 cabling	382
5.3.6	Replacing the axis-5 cabling	420
5.3.7	Replacing the axis-6 cabling	466
5.3.8	Replacing the axis-5 to axis-6 transition cabling	490
5.3.9	Replacing the brake release unit	491
5.4	Upper and lower arms	509
5.4.1	Replacing the lower arm	509
5.4.2	Replacing the housing	528
5.4.3	Replacing the tubular	565
5.4.4	Replacing the wrist housing	599
5.4.5	Replacing the tool flange and axis-6 inner flange	638
5.4.6	Replacing the arm-side interface	645

5.5	Swing and base	649
5.5.1	Replacing the base	649
5.5.2	Replacing the swing	724
5.6	Joint units	776
5.6.1	Replacing the axis-1 joint unit (CRB 15000-5/0.95)	776
5.6.2	Replacing the axis-1 joint unit (CRB 15000-10/1.52 and CRB 15000-12/1.27)	816
5.6.3	Replacing the axis-2 joint unit (CRB 15000-5/0.95)	860
5.6.4	Replacing the axis-2 joint unit (CRB 15000-10/1.52 and CRB 15000-12/1.27)	888
5.6.5	Replacing the axis-3 joint unit	917
5.6.6	Replacing the axis-4 joint unit	954
5.6.7	Replacing the axis-5 joint unit and the axis-5 to axis-6 transition cabling	992
5.6.8	Replacing the axis-6 joint unit	1039
6	Calibration	1063
6.1	Calibration methods	1063
6.2	Calibrating the torque sensors	1065
6.3	Jogging directions	1067
6.4	Calibrating with Wrist Optimization method	1068
7	Troubleshooting	1071
7.1	Introduction to troubleshooting	1071
7.2	Mechanical noise or dissonance	1073
7.3	Manipulator collapses on power down	1074
7.4	Brake release tool does not work	1075
7.5	Drive system communication link and DC link are both down during robot running	1077
7.6	Communication failure between PROFIsafe-based laser scanner, PLC, and controller	1078
7.7	Communication failure between PLC and controller	1079
7.8	Communication failure between scalable I/O device and controller	1081
7.9	System failure when changing PROFINET-based laser scanner to SafetyIO-based laser scanner	1082
7.10	Movement in Safe area not in full speed or at zero speed	1083
7.11	Unable to remove or reselect installed options in Collaborative Speed Control add-in	1084
7.12	Unexpected robot movement when starting the program in Protecting Area	1085
7.13	Diagnostic LEDs on joint unit drive board	1086
8	Decommissioning	1089
8.1	Introduction to decommissioning	1089
8.2	Environmental information	1090
8.3	Scrapping of robot	1092
9	Reference information	1093
9.1	Introduction	1093
9.2	Applicable standards	1094
9.3	Unit conversion	1096
9.4	Screw joints	1097
9.5	Weight specifications	1098
9.6	Standard toolkit	1099
9.7	Special tools	1100
Index		1103

This page is intentionally left blank

Overview of this manual

About this manual

This manual contains instructions for:

- mechanical and electrical installation of the CRB 15000
- maintenance of the CRB 15000
- mechanical and electrical repair of the CRB 15000

The robot described in this manual has the following protection types:

- *Standard*

Product manual scope

The manual covers all variants and designs of the CRB 15000. Some variants and designs may have been removed from the business offer and are no longer available for purchase.

Usage

This manual should be used during:

- installation and commissioning, from lifting the product to its work site and securing it to the foundation, to making it ready for operation
- maintenance work
- repair work
- decommissioning work



Note

It is the responsibility of the integrator to conduct a risk assessment of the final application.

It is the responsibility of the integrator to provide safety and user guides for the robot system.



Note

Significant potential hazards for robot systems are listed in ISO 10218-2. ISO 12100 provides examples of the hazards associated with machines.

Who should read this manual?

This manual is intended for:

- installation personnel
- maintenance personnel
- repair personnel.

Continues on next page

Overview of this manual

Continued

Prerequisites

A maintenance/repair/installation craftsman working with an ABB robot must:

- be trained by ABB and have the required knowledge of mechanical and electrical installation/repair/maintenance work.
- be trained to respond to emergencies or abnormal situations.

References

Documentation referred to in the manual, is listed in the table below.

Document name	Document ID
<i>Product manual, spare parts - CRB 15000</i>	3HAC079469-001
<i>Product specification - CRB 15000</i>	3HAC077390-001
<i>Product manual - OmniCore C30</i>	3HAC060860-001
<i>Circuit diagram - CRB 15000</i>	3HAC081041-003
<i>Operating manual - Integrator's guide OmniCore</i>	3HAC065037-001
<i>Technical reference manual - System parameters</i>	3HAC065041-001
<i>Application manual - Functional safety and SafeMove</i>	3HAC066559-001
<i>Application manual - PROFINET Controller/Device</i>	3HAC066558-001
<i>Application manual - Force control Standard for GoFa</i>	3HAC083267-001
<i>Technical reference manual - Event logs for RobotWare 7</i>	3HAC066553-001



Tip

All documents can be found via myABB Business Portal, www.abb.com/myABB.

Revisions

Revision	Description
A	First edition.
B	Published in release 21B. The following updates are made in this revision: <ul style="list-style-type: none">• Added procedure for refitting the axis-4 cover in the replacement procedure for the axis-5 joint unit.• Changed the tightening torque for the axis-4 and axis-5 covers.• Added procedure for refitting the swing in the replacement procedure for the base.• Added step for removing and refitting cable bracket in replacement procedure for the lower arm.• Corrected safety data.• Updated information about SafeMove for the CRB 15000.• Updated information about the arm-side interface, see Working closely with the robot in a safe way on page 111.• Added information about how to calibrate the robot, see Calibration on page 1063.• Updated spare part number for axis-3 joint unit.

Continues on next page

Revision	Description
C	<p>Published in release 21C. The following updates are made in this revision:</p> <ul style="list-style-type: none"> • Updated information related to the safety data, and the brake closing time is updated. • Updated how to initiate the calibration service routine. • Updated information about <i>Cyclic Brake Check</i> in the maintenance section. • Updated article number for brake release tool. • Added information about rotating connector at the manipulator base, see Connectors at the base on page 102.
D	<p>Published in release 21D. The following updates are made in this revision:</p> <ul style="list-style-type: none"> • Added information about laser scanner. • Added tip in section Calibration methods on page 1063. • Updated working range for axis 6, see Working range on page 52.
E	<p>Published in release 22A. The following updates are made in this revision:</p> <ul style="list-style-type: none"> • Updated information about ASI buttons. • Added tips about the calibration features, see Features in the routine on page 1065. • Updated information for the SafeMove function Human Contact Supervision. • Updated information for lead-through, see Lead-through on page 117. • Added information about length of thread engagement for attachment screws. • Added foundation material yield strength data. • Updated information about response times in section Safety data on page 45. • Updated information about Gleitmo treated screws, see Screw joints on page 1097. • Updated replacement procedures for axis-2, axis-3, axis-4, axis-5 and axis-6 cabling. • Information about online user guide added in section The Safe-Move configurator app on FlexPendant on page 120. • Added more information for laser scanners.
F	<p>Published in release 22B. The following updates are made in this revision:</p> <ul style="list-style-type: none"> • Corrected wire rating for customer cabling. • Added diagnostic data for drive board LEDs. • Updated operating conditions regarding ambient humidity. • Updated information regarding the torque sensor calibration routine. • Added connector designations to drive board images in replacement procedures. • Added information about changing laser scanner type.
G	<p>Published in release 22C. The following updates are made in this revision:</p> <ul style="list-style-type: none"> • Added pin specification for the customer connectors at the tool flange. • Added usable detergents to the cleaning section. • Added protection class for clean room suitability. • Changed tool designation and article number for cable tie gun. • Minor corrections. • Updated the connection figures and configuration procedure of the safetyIO-based laser scanners. • Removed the troubleshooting for issue of RED flashing status on Scalable I/O device and failure to move the robot.

Continues on next page

Revision	Description
H	Published in release 22D. The following updates are made in this revision: <ul style="list-style-type: none">• Added support for wrist optimization.
J	Published in release 23A. The following updates are made in this revision: <ul style="list-style-type: none">• Added information for new brake release functionality using the FlexPendant.• Added support for the option <i>Absolute Accuracy</i>.• Added information about releasing the brakes by using the FlexPendant.
K	Published in release 23A. The following updates are made in this revision: <ul style="list-style-type: none">• Updated requirement and procedure descriptions for manually releasing the brakes.
L	Published in release 23B. The following updates are made in this revision: <ul style="list-style-type: none">• Added new variants CRB 15000-10/1.52 and CRB 15000-12/1.27.• Added pin assignment on XG1 connector of SafetyIO-based laser scanner.• Updated the logical expressions for SafeMove configuration using Visual SafeMove, see Configuring pre logic on page 135.

Product documentation

Categories for user documentation from ABB Robotics

The user documentation from ABB Robotics is divided into a number of categories. This listing is based on the type of information in the documents, regardless of whether the products are standard or optional.



Tip

All documents can be found via myABB Business Portal, www.abb.com/myABB.

Product manuals

Manipulators, controllers, DressPack/SpotPack, and most other hardware is delivered with a **Product manual** that generally contains:

- Safety information.
- Installation and commissioning (descriptions of mechanical installation or electrical connections).
- Maintenance (descriptions of all required preventive maintenance procedures including intervals and expected life time of parts).
- Repair (descriptions of all recommended repair procedures including spare parts).
- Calibration.
- Troubleshooting.
- Decommissioning.
- Reference information (safety standards, unit conversions, screw joints, lists of tools).
- Spare parts list with corresponding figures (or references to separate spare parts lists).
- References to circuit diagrams.

Technical reference manuals

The technical reference manuals describe reference information for robotics products, for example lubrication, the RAPID language, and system parameters.

Application manuals

Specific applications (for example software or hardware options) are described in **Application manuals**. An application manual can describe one or several applications.

An application manual generally contains information about:

- The purpose of the application (what it does and when it is useful).
- What is included (for example cables, I/O boards, RAPID instructions, system parameters, software).
- How to install included or required hardware.
- How to use the application.

Continues on next page

- Examples of how to use the application.

Operating manuals

The operating manuals describe hands-on handling of the products. The manuals are aimed at those having first-hand operational contact with the product, that is production cell operators, programmers, and troubleshooters.

How to read the product manual

Reading the procedures

The procedures contain all information required for the installation or service activity and can be printed out separately when needed for a certain service procedure.

Safety information

The manual includes a separate safety chapter that must be read through before proceeding with any service or installation procedures. All procedures also include specific safety information when dangerous steps are to be performed.

Read more in the chapter [Safety on page 17](#).

Illustrations

The product is illustrated with general figures that does not take painting or protection type in consideration.

Likewise, certain work methods or general information that is valid for several product models, can be illustrated with illustrations that show a different product model than the one that is described in the current manual.

This page is intentionally left blank

1 Safety

1.1 Safety information

1.1.1 Limitation of liability

Limitation of liability

Any information given in this manual regarding safety must not be construed as a warranty by ABB that the industrial robot will not cause injury or damage even if all safety instructions are complied with.

The information does not cover how to design, install and operate a robot system, nor does it cover all peripheral equipment that can influence the safety of the robot system.

In particular, liability cannot be accepted if injury or damage has been caused for any of the following reasons:

- Use of the robot in other ways than intended.
- Incorrect operation or maintenance.
- Operation of the robot when the safety devices are defective, not in their intended location or in any other way not working.
- When instructions for operation and maintenance are not followed as intended.
- Non-authorized design modifications of the robot.
- Repairs on the robot and its spare parts carried out by in-experienced or non-qualified personnel.
- Foreign objects.
- Force majeure.

Intended use

The ABB robot is intended for automation of different tasks including moving/handling parts and production equipment or carrying sensors etc. Application ranges from traditional manufacturing to services.

The integrator of the robot system is required to perform an assessment of the hazards and risks.

Continues on next page

1 Safety

1.1.1 Limitation of liability

Continued

The CRB 15000-5/0.95 can only be used with the ABB OmniCore C30 controller with Drive system 7, and the CRB 15000-10/1.52 and CRB 15000-12/1.27 can only be used with the ABB OmniCore C30 controller with Drive system 10.



Note

The type of drive system installed in the controller can be found on the drive label on the controller cabinet. Always verify the drive label before connecting the controller to the manipulator.

Controllers delivered in RobotWare versions earlier than 7.10 may not have a Drive label attached. Then the integrator must clearly mark an observed symbol on the controller to avoid incorrect connections.

For more information see:

- *Product manual - OmniCore C30*

Spare parts and equipment

ABB supplies original spare parts and equipment which have been tested and approved for their intended use. The installation and/or use of non-original spare parts and equipment can negatively affect the safety, function, performance, and structural properties of the robot. ABB is not liable for damages caused by the use of non-original spare parts and equipment.

1.1.2 Requirements on personnel

General

Only personnel with appropriate training are allowed to install, maintain, service, repair, and use the robot. This includes electrical, mechanical, hydraulics, pneumatics, and other hazards identified in the risk assessment.

Persons who are under the influence of alcohol, drugs or any other intoxicating substances are not allowed to install, maintain, service, repair, or use the robot.

The plant liable must make sure that the personnel is trained on the robot, and on responding to emergency or abnormal situations.

Personal protective equipment

Use personal protective equipment, as stated in the instructions.

Risk of entanglement

Loose clothing should not be worn and long hair should be tied up to reduce the risk for entanglement.

1 Safety

1.2.1 Safety signals in the manual

1.2 Safety signals and symbols

1.2.1 Safety signals in the manual







Introduction to safety signals

This section specifies all safety signals used in the user manuals. Each signal consists of:

- A caption specifying the hazard level (DANGER, WARNING, or CAUTION) and the type of hazard.
- Instruction about how to reduce the hazard to an acceptable level.
- A brief description of remaining hazards, if not adequately reduced.

Hazard levels

The table below defines the captions specifying the hazard levels used throughout this manual.

Symbol	Designation	Significance
	DANGER	Signal word used to indicate an imminently hazardous situation which, if not avoided, will result in serious injury.
	WARNING	Signal word used to indicate a potentially hazardous situation which, if not avoided, could result in serious injury.
	ELECTRICAL SHOCK	Signal word used to indicate a potentially hazardous situation related to electrical hazards which, if not avoided, could result in serious injury.
	CAUTION	Signal word used to indicate a potentially hazardous situation which, if not avoided, could result in slight injury.
	ELECTROSTATIC DISCHARGE (ESD)	Signal word used to indicate a potentially hazardous situation which, if not avoided, could result in severe damage to the product.
	NOTE	Signal word used to indicate important facts and conditions.

Continues on next page

Symbol	Designation	Significance
	TIP	Signal word used to indicate where to find additional information or how to do an operation in an easier way.

1 Safety

1.2.2 Safety symbols on manipulator labels

1.2.2 Safety symbols on manipulator labels

Introduction to symbols

This section describes safety symbols used on labels (stickers) on the manipulator. Symbols are used in combinations on the labels, describing each specific warning. The descriptions in this section are generic, the labels can contain additional information such as values.



Note

The symbols on the labels on the product must be observed. Additional symbols added by the integrator must also be observed.



Types of symbols

Both the manipulator and the controller are marked with symbols, containing important information about the product. This is important for all personnel handling the robot, for example during installation, service, or operation.



The safety labels are language independent, they only use graphics. See [Symbols on safety labels on page 22](#).

The information labels can contain information in text.

Symbols on safety labels

Symbol	Description
 xx0900000812	Warning! Warns that an accident <i>may</i> occur if the instructions are not followed that can lead to serious injury, possibly fatal, and/or great damage to the product. It applies to warnings that apply to danger with, for example, contact with high voltage electrical units, explosion or fire risk, risk of poisonous gases, risk of crushing, impact, fall from height, etc.
 xx0900000811	Caution! Warns that an accident may occur if the instructions are not followed that can result in injury and/or damage to the product. It also applies to warnings of risks that include burns, eye injury, skin injury, hearing damage, crushing or slipping, tripping, impact, fall from height, etc. Furthermore, it applies to warnings that include function requirements when fitting and removing equipment where there is a risk of damaging the product or causing a breakdown.
 xx0900000839	Prohibition Used in combinations with other symbols.

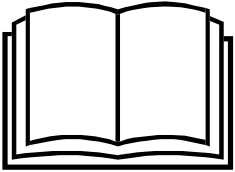
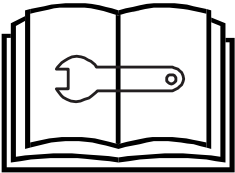
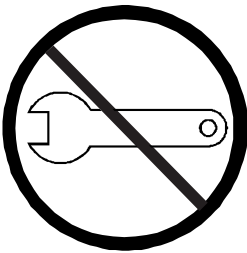
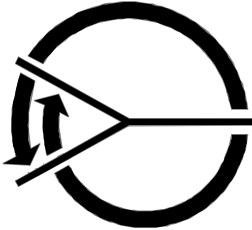



Continues on next page

Symbol	Description
 <p>xx0900000813</p>	<p>See user documentation Read user documentation for details. Which manual to read is defined by the symbol:</p> <ul style="list-style-type: none"> No text: <i>Product manual</i>.
 <p>xx0900000816</p>	<p>Before disassembly, see product manual</p>
 <p>xx0900000815</p>	<p>Do not disassemble Disassembling this part can cause injury.</p>
 <p>xx0900000814</p>	<p>Extended rotation This axis has extended rotation (working area) compared to standard.</p>
 <p>xx0900000808</p>	<p>Brake release Using the brake release tool will release the brakes. This means that the robot arm can fall down.</p>



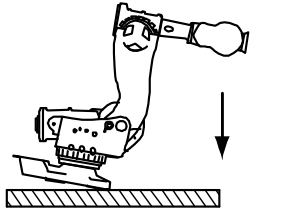

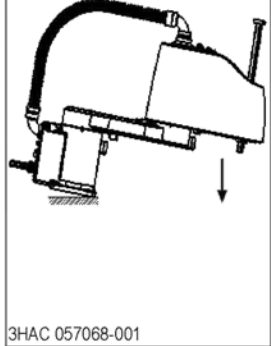
1 Safety

1.2.2 Safety symbols on manipulator labels

Continued

Symbol	Description
 <p>xx0900000810</p>   <p>3HAC 057068-001</p> <p>xx1500002402</p>	<p>Tip risk when loosening bolts The robot can tip over if the bolts are not securely fastened.</p>
 <p>xx0900000817</p>	<p>Crush Risk of crush injuries.</p>

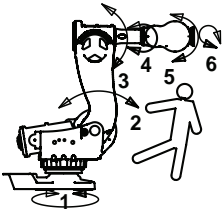
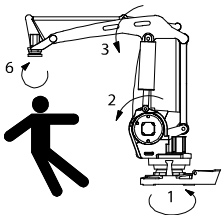
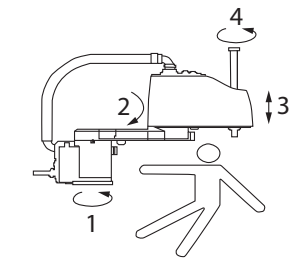



Continues on next page

Symbol	Description
 <p>xx0900000818</p>  <p>xx1300001087</p>	<p>Heat Risk of heat that can cause burns. (Both signs are used)</p>
 <p>xx0900000819</p>  <p>xx1000001141</p>  <p>xx1500002616</p>	<p>Moving robot The robot can move unexpectedly.</p>
 <p>xx0900000821</p>	<p>Lifting bolt</p>

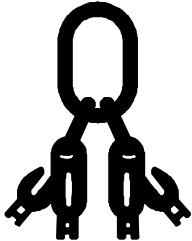

1 Safety

1.2.2 Safety symbols on manipulator labels

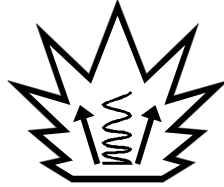
Continued

Symbol	Description
 xx1000001242	Adjustable chain sling with shortener
 xx0900000822	Lifting of robot
 xx0900000823	Oil Can be used in combination with prohibition if oil is not allowed.
 xx0900000824	Mechanical stop
 xx1000001144	No mechanical stop
 xx0900000825	Stored energy Warns that this part contains stored energy. Used in combination with <i>Do not disassemble</i> symbol.

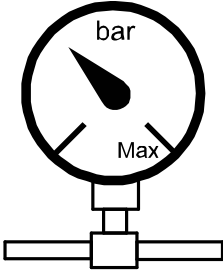
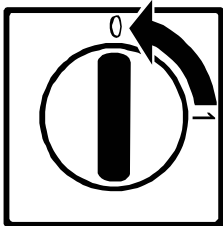
Continues on next page

Symbol	Description
 <p>xx0900000826</p>	<p>Pressure Warns that this part is pressurized. Usually contains additional text with the pressure level.</p>
 <p>xx0900000827</p>	<p>Shut off with handle Use the power switch on the controller.</p>
 <p>xx1400002648</p>	<p>Do not step Warns that stepping on these parts can cause damage to the parts.</p>

1.3 Robot stopping functions

Protective stop and emergency stop

The protective stops and emergency stops are described in the product manual for the controller.

For more information see:

- *Product manual - OmniCore C30*

Reasons for selection of stops in CRB 15000

For nearly all safety functions in CRB 15000, a category 1 stop is defined.

Exceptions are only allowed:

- When there is a technical fault in the system, or
- If the standstill supervision (category 2 stop) condition is violated. This is required by ISO 10218-1 §5.5.3.

Category 1 stops are used otherwise because:

- Stopping using the motor produces repeatable stopping distances (no variation of brake friction coefficient).
- Stopping using the motor produces the shortest stopping distance without any risk of overloading structural components (pre-defined braking torque, no delay).
- Stopping using the motor saves on brake wear, so that the brake can perform its primary (holding) function for longer.
- An off-path category 1 stop is best suited to *Power and Force Limiting*: it stops as fast as possible and does not try to maintain the path, so minimizing the forces applied by the robot.

Because of these reasons, the end user/system integrator should always use a category 1 stop for CRB 15000 *Safety Functions* in the application risk assessment.

1.4 Safety during installation and commissioning

National or regional regulations

The integrator of the robot system is responsible for the safety of the robot system.

The integrator is responsible that the robot system is designed and installed in accordance with the safety requirements set forth in the applicable national and regional standards and regulations.

The integrator of the robot system is required to perform a risk assessment.

Layout

The robot integrated to a robot system shall be designed to allow safe access to all spaces during installation, operation, maintenance, and repair.

If robot movement can be initiated from an external control panel then an emergency stop must also be available.

Consider exposure to hazards, such as slipping, tripping, and falling.

Hazards due to the working position and posture for a person working with or near the robot shall be considered.

Hazards due to noise emission from the robot needs to be considered.

Allergenic material

See [Environmental information on page 1090](#) for specification of allergenic materials in the product, if any.

Securing the robot to the foundation

The robot must be properly fixed to its foundation/support, as described in the respective product manual.

When the robot is installed at a height, hanging, or other than mounted directly on the floor, there will be additional hazards.

Electrical safety

Incoming mains must be installed to fulfill national regulations.

The power supply wiring to the robot must be sufficiently fused and if necessary, it must be possible to disconnect it manually from the mains power.

The power to the robot must be turned off with the main switch and the mains power disconnected when performing work inside the controller cabinet. Lock and tag shall be considered.

Harnesses between controller and manipulator shall be fixed and protected to avoid tripping and wear.

Wherever possible, power on/off or rebooting the robot controller shall be performed with all persons outside the safeguarded space.



Note

Use a CARBON DIOXIDE (CO₂) extinguisher in the event of a fire in the robot.

Continues on next page

1 Safety

1.4 Safety during installation and commissioning

Continued

Safety devices

The integrator is responsible for that the safety devices necessary to protect people working with the robot system are designed and installed correctly.

When integrating the robot with external devices to a robot system:

- The integrator of the robot system must ensure that emergency stop functions are interlocked in accordance with applicable standards.
- The integrator of the robot system must ensure that safety functions are interlocked in accordance with applicable standards.

Other hazards

The risk assessment should also consider other hazards arising from the application, such as, but not limited to:

- Water
- Compressed air
- Hydraulics

End-effector hazards require particular attention for applications which involve close human collaboration with the robot.

Specific information for GoFa robots

The CRB 15000 collaborative robot is designed to be able to work safely alongside humans and even share tasks with them. It is vital for the user of the robot to operate it in a safe way, setting up the necessary safety configurations, and ensure that appropriate risk reduction measures are implemented. See sections [Working closely with the robot in a safe way on page 111](#), and [The SafeMove configurator app on FlexPendant on page 120](#), as well as [Guidelines for transient and quasi-static contact, CRB 15000 on page 132](#) for details on how to do this.

The CRB 15000 collaborative robot has no provision for mechanical stops to limit axis motion (see ISO 10218-1, §5.12.1). Instead, safety-related soft axis limiting (see ISO 10218-1, §5.12.3) should be used to limit motion if required. This can be implemented using the safety function *Axis Position Supervision*, described in the SafeMove manual.

Verify the safety functions

Before the robot system is put into operation, verify that the safety functions are working as intended and that any remaining hazards identified in the risk assessment are mitigated to an acceptable level.

1.5 Safety during operation

Automatic operation

Verify the application in the operating mode manual reduced speed, before changing mode to automatic and initiating automatic operation.

Unexpected movement of robot arm



WARNING

Hazards due to the use of brake release devices and/or gravity beneath the manipulator shall be considered.

Hot surfaces

Touch surface temperatures shall be verified when running demanding motion cycles at high ambient temperatures. If necessary, to prevent burns, allow touch surfaces to cool down before working closely with the robot.

The following figure takes the CRB 15000-12/1.27 as an example to show the locations of touch surfaces. All the other surfaces are considered as non-touch surfaces.

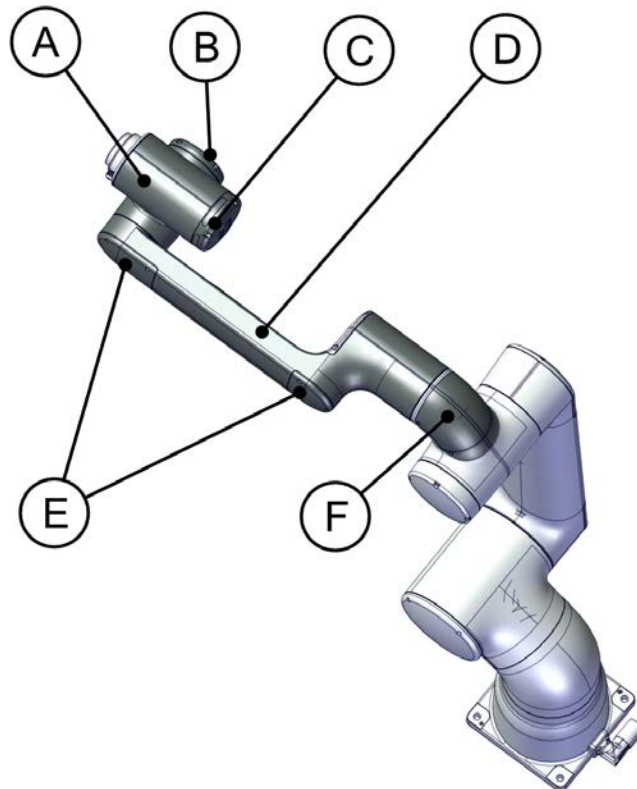

xx230000975

A	Wrist housing
B	Axis-5 cover

Continues on next page

1 Safety

1.5 Safety during operation

Continued

C	Arm side interface
D	Tubular
E	Tubular covers
F	Housing cover

1.6 Safety during maintenance and repair

1.6.1 Safety during maintenance and repair

General

Corrective maintenance must only be carried out by personnel trained on the robot. Maintenance or repair must be done with all electrical, pneumatic, and hydraulic power switched off, that is, no remaining hazards.

Make sure that there are no loose screws, turnings, or other unexpected parts remaining after work on the robot has been performed.

When the work is completed, verify that the safety functions are working as intended.

Hot surfaces

Surfaces can be hot after running the robot, and touching these may result in burns. Allow the surfaces to cool down before maintenance or repair.

Allergic reaction

Warning	Description	Elimination/Action
 <p>Allergic reaction</p>	When working with lubricants there is a risk of an allergic reaction.	Make sure that protective gear like goggles and gloves are always worn.

Gearbox lubricants (oil or grease)

When handling oil, grease, or other chemical substances the safety information of the respective manufacturer must be observed.



Note

Take special care when handling hot lubricants.

Risk of exceeding design life

Regular inspections, maintenance, and exchange of worn components are essential to ensure the safe operation of this robot. Follow the instructions in section [Maintenance on page 183](#).

Related information

See also the safety information related to installation and operation.

1 Safety

1.6.2 Emergency release of the robot axes

1.6.2 Emergency release of the robot axes

Description

How to release the brakes is described in the section:

- [Manually releasing the brakes on page 69.](#)

1.6.3 Brake testing

When to test

During operation, the holding brake of each axis normally wears down. A test can be performed to determine whether the brake can still perform its function.

How to test

The function of the holding brake of each axis motor may be verified as described below:

- 1 Run each axis to a position where the combined weight of the manipulator and any load is maximized (maximum static load).
- 2 Switch the motor to the MOTORS OFF.
- 3 Inspect and verify that the axis maintains its position.

If the manipulator does not change position as the motors are switched off, then the brake function is adequate.



Note

It is recommended to run the service routine *BrakeCheck* as part of the regular maintenance, see the operating manual for the robot controller.

For robots with the option SafeMove, the *Cyclic Brake Check* routine is recommended. See the manual for SafeMove in [References on page 10](#).

1 Safety

1.7 Safety during troubleshooting

1.7 Safety during troubleshooting

General

When troubleshooting requires work with power switched on, special considerations must be taken:

- Safety circuits might be muted or disconnected.
- Electrical parts must be considered as *live*.
- The manipulator can move unexpectedly at any time.



DANGER

Troubleshooting on the controller while powered on must be performed by personnel trained by ABB or by ABB field engineers.

A risk assessment must be done to address both robot and robot system specific hazards.

Related information

See also the safety information related to installation, operation, maintenance, and repair.

1.8 Safety during decommissioning

General

See section [Decommissioning on page 1089](#).

If the robot is decommissioned for storage, take extra precaution to reset safety devices to delivery status.

This page is intentionally left blank

2 Manipulator description

2.1 About CRB 15000

Introduction

The CRB 15000 robot is a flexible, agile 6-axis articulated robot, available in three variants spanning various options for payload from 5 kg to 12 kg, wrist reach from 0.95 m to 1.52 m (flange reach from 1.05 m to 1.62 m), and designed specifically for manufacturing industries that use flexible robot-based automation. The robot has an open structure that is especially adapted for flexible use, and can communicate extensively with external systems.



Note

The CRB 15000-5/0.95 can only be used with the ABB OmniCore C30 controller with Drive system 7, and the CRB 15000-10/1.52 and CRB 15000-12/1.27 can only be used with the ABB OmniCore C30 controller with Drive system 10.

The type of drive system installed in the controller can be found on the Drive label on the controller cabinet. Always verify the Drive label before connecting the controller to the manipulator.

Controllers delivered in RobotWare versions earlier than 7.10 may not have a Drive label attached. Then the integrator must clearly mark an observed symbol on the controller to avoid incorrect connections.

For more information see:

- *Product manual - OmniCore C30*

2 Manipulator description

2.2 Technical data

2.2 Technical data

Weight, robot

The table shows the weight of the robot.

Robot model	Nominal weight
CRB 15000-5/0.95	28 kg
CRB 15000-10/1.52	51 kg
CRB 15000-12/1.27	48 kg



Note

The weight does not include additional options, tools and other equipment fitted on the robot.

Mounting positions

The table shows valid mounting positions and the installation (mounting) angle for the manipulator.

Mounting position	Installation angle
Floor mounted	0°
Wall mounted	Any angle
Suspended	180°



Note

The actual mounting angle must always be configured in the system parameters, otherwise the performance and lifetime is affected. See [Setting the system parameters for an inverted or a tilted robot on page 77](#).

Loads on foundation, robot

The illustration shows the directions of the robots stress forces.

Continues on next page

The directions are valid for all floor mounted, table mounted, wall mounted and suspended robots.

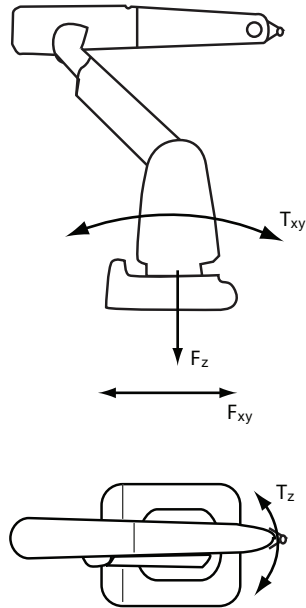

xx1100000521

F_{xy}	Force in any direction in the XY plane
F_z	Force in the Z plane
T_{xy}	Bending torque in any direction in the XY plane
T_z	Bending torque in the Z plane

The table shows the various forces and torques working on the robot during different kinds of operation.



Note

These forces and torques are extreme values that are rarely encountered during operation. The values also never reach their maximum at the same time!



WARNING

The robot installation is restricted to the mounting options given in following load table(s).

Floor mounted

Force	Endurance load (in operation)	Maximum load (emergency stop)
Force xy	$\pm 303 \text{ N}^i / \pm 470 \text{ N}^{ii} / \pm 470 \text{ N}^{iii}$	$\pm 1113 \text{ N}^i / \pm 1460 \text{ N}^{ii} / \pm 1450 \text{ N}^{iii}$
Force z	$+280 \pm 147 \text{ N}^i / +500 \pm 410 \text{ N}^{ii} / +480 \pm 420 \text{ N}^{iii}$	$+280 \pm 857 \text{ N}^i / +500 \pm 650 \text{ N}^{ii} / +480 \pm 690 \text{ N}^{iii}$
Torque xy	$\pm 246 \text{ Nm}^i / \pm 570 \text{ Nm}^{ii} / \pm 580 \text{ Nm}^{iii}$	$\pm 711 \text{ Nm}^i / \pm 1,280 \text{ Nm}^{ii} / \pm 1,180 \text{ Nm}^{iii}$
Torque z	$\pm 145 \text{ Nm}^i / \pm 200 \text{ Nm}^{ii} / \pm 210 \text{ Nm}^{iii}$	$\pm 334 \text{ Nm}^i / \pm 720 \text{ Nm}^{ii} / \pm 690 \text{ Nm}^{iii}$

ⁱ Valid for CRB 15000-5/0.95.

Continues on next page

2 Manipulator description

2.2 Technical data

Continued

- ii Valid for CRB 15000-10/1.52.
- iii Valid for CRB 15000-12/1.27.

Wall mounted

Force	Endurance load (in operation)	Max. load (emergency stop)
Force xy	+280 ±130 N ⁱ / +510 ±490 N ⁱⁱ / +480 ±450 N ⁱⁱⁱ	+280 ±1000 N ⁱ / +510 ±1220 N ⁱⁱ / +480 ±1260 N ⁱⁱⁱ
Force z	±289 N ⁱ / ±390 N ⁱⁱ / ±360 N ⁱⁱⁱ	±944 N ⁱ / ±900 N ⁱⁱ / ±1150 N ⁱⁱⁱ
Torque xy	±275 Nm ⁱ / ±700 Nm ⁱⁱ / ±677 Nm ⁱⁱⁱ	±768 Nm ⁱ / ±2,000 Nm ⁱⁱ / ±1,970 Nm ⁱⁱⁱ
Torque z	±162 Nm ⁱ / ±400 Nm ⁱⁱ / ±370 Nm ⁱⁱⁱ	±338 Nm ⁱ / ±780 Nm ⁱⁱ / ±790 Nm ⁱⁱⁱ

- i Valid for CRB 15000-5/0.95.
- ii Valid for CRB 15000-10/1.52.
- iii Valid for CRB 15000-12/1.27.

Suspended

Force	Endurance load (in operation)	Max. load (emergency stop)
Force xy	±303 N ⁱ / ±470 N ⁱⁱ / ±470 N ⁱⁱⁱ	±1113 N ⁱ / ±1460 N ⁱⁱ / ±1450 N ⁱⁱⁱ
Force z	-280 ±147 N ⁱ / +500 ±410 N ⁱⁱ / +480 ±420 N ⁱⁱⁱ	-280 ±857 N ⁱ / +500 ±650 N ⁱⁱ / +480 ±690 N ⁱⁱⁱ
Torque xy	±246 Nm ⁱ / ±570 Nm ⁱⁱ / ±580 Nm ⁱⁱⁱ	±711 Nm ⁱ / ±1,280 Nm ⁱⁱ / ±1,180 Nm ⁱⁱⁱ
Torque z	±145 Nm ⁱ / ±200 Nm ⁱⁱ / ±210 Nm ⁱⁱⁱ	±334 Nm ⁱ / ±720 Nm ⁱⁱ / ±690 Nm ⁱⁱⁱ

- i Valid for CRB 15000-5/0.95.
- ii Valid for CRB 15000-10/1.52.
- iii Valid for CRB 15000-12/1.27.

Requirements, foundation

The table shows the requirements for the foundation where the weight of the installed robot is included:

Requirement	Value	Note
Flatness of foundation surface	0.1/500 mm	The value for levelness aims at the circumference of the anchoring points in the robot base. In order to compensate for an uneven surface, the robot can be recalibrated during installation. If resolver/encoder calibration is changed this will influence the absolute accuracy.
Minimum resonance frequency	22Hz  Note It may affect the manipulator lifetime to have a lower resonance frequency than recommended.	The value is recommended for optimal performance. Due to foundation stiffness, consider robot mass including equipment. ⁱ For information about compensating for foundation flexibility, see the description of <i>Motion Process Mode</i> in the manual that describes the controller software option, see References on page 10 .

Continues on next page

Requirement	Value	Note
Minimum foundation material yield strength	150 Mpa	

- i The minimum resonance frequency given should be interpreted as the frequency of the robot mass/inertia, robot assumed stiff, when a foundation translational/torsional elasticity is added, i.e., the stiffness of the pedestal where the robot is mounted. The minimum resonance frequency should not be interpreted as the resonance frequency of the building, floor etc. For example, if the equivalent mass of the floor is very high, it will not affect robot movement, even if the frequency is well below the stated frequency. The robot should be mounted as rigid as possible to the floor.
- Disturbances from other machinery will affect the robot and the tool accuracy. The robot has resonance frequencies in the region 10 – 20 Hz and disturbances in this region will be amplified, although somewhat damped by the servo control. This might be a problem, depending on the requirements from the applications. If this is a problem, the robot needs to be isolated from the environment.

Storage conditions, robot

The table shows the allowed storage conditions for the robot:

Parameter	Value
Minimum ambient temperature	-40 °C
Maximum ambient temperature	70 °C
Maximum ambient temperature (less than 24 hrs)	70 °C
Maximum ambient humidity	95% at constant temperature (not intended to operate with condensation)
Maximum ambient altitude	0-3,000 m (100-74 kPa)

Operating conditions, robot

The table shows the allowed operating conditions for the robot:

Parameter	Value
Minimum ambient temperature	5 °C ⁱ
Maximum ambient temperature	40 °C ⁱⁱ / 45 °C ⁱⁱⁱ
Maximum ambient humidity	<75% relative humidity For limited period of time (<1 month): <95% relative humidity ^{iv}
Maximum ambient altitude	0-2,000 m (100-84 kPa)

- i At low environmental temperature < 10°C as with any other machine, a warm-up phase recommended to be run with the robot. Otherwise there is a risk that the robot stops or run with lower performance due to temperature dependent oil and grease viscosity.
- ii Valid for CRB 15000-5/0.95.
- iii Valid for CRB 15000-10/1.52 and CRB 15000-12/1.27.
- iv Depending on climate and robot running conditions, condensation may occur on the inside of plastic covers. The condensation will disappear over time by itself, alternatively the user can open the covers and run a program for 12 hours to accelerate the process.

Protection classes, robot

The table shows the available protection types of the robot, with the corresponding protection class.

Protection type	Protection class ⁱ
Manipulator, protection type Standard (CRB 15000-5/0.95)	IP54 Type 12k ⁱⁱ NEMA 12k ⁱⁱⁱ

Continues on next page

2 Manipulator description

2.2 Technical data

Continued

Protection type	Protection class ⁱ
Manipulator, protection type Standard (CRB 15000-10/1.52 and CRB 15000-12/1.27)	IP67

ⁱ According to IEC 60529.

ⁱⁱ According to UL50/UL50E, CSA C22.2 No 94.2-15.

ⁱⁱⁱ According to NEMA 250.

Clean room suitability, robot

The table shows the suitability for clean room environment for the valid protection types of the robot.

Protection type	Protection class
Manipulator, suitability class (protection type Standard)	ISO Class 4 ⁱ

ⁱ According to ISO 14644-1 / ISO 14644-14.

Harsh environment

The manipulator complies with the following harsh environment.

Parameter	According to
Flowing, mixed gas corrosion test	ISA-71.04-2013 G3 Harsh Group A DIN EN 60068-2-60

Components and concentrations of the mixed corrosive gas:

- Hydrogen sulphide (H₂S): 50 ppb
- Nitrogen dioxide (NO₂): 1,250 ppb
- Chlorine (Cl₂): 10 ppb
- Sulphur dioxide (SO₂): 300 ppb

Environmental information

The product complies with IEC 63000. *Technical documentation for the assessment of electrical and electronic products with respect to the restriction of hazardous substances.*

Joint torques

The following table shows the maximum torque for each joint. The maximum value can be achieved on one axis at a time.

Axis	Maximum joint torque
1	175.44 Nm ⁱ / 450 Nm ⁱⁱ / 390 Nm ⁱⁱⁱ
2	175.44 Nm ⁱ / 400 Nm ⁱⁱ / 400 Nm ⁱⁱⁱ
3	90.6 Nm ⁱ / 160 Nm ⁱⁱ / 160 Nm ⁱⁱⁱ
4	18.72 Nm ⁱ / 60 Nm ⁱⁱ / 60 Nm ⁱⁱⁱ
5	21.44 Nm ⁱ / 60 Nm ⁱⁱ / 60 Nm ⁱⁱⁱ
6	9.2 Nm ⁱ / 60 Nm ⁱⁱ / 60 Nm ⁱⁱⁱ

ⁱ Valid for CRB 15000-5/0.95.

ⁱⁱ Valid for CRB 15000-10/1.52.

ⁱⁱⁱ Valid for CRB 15000-12/1.27.

2.3 Safety data

Prevailing standards and directives

For the use of industrial robots, regulations must be fulfilled as described in the following standards and directives:

- EN ISO 10218-1:2011
- Machinery Directive 2006/42/EC

Performance level and category

EN ISO 10218-1 requires structure category 3 and performance level *PL d* on the robot, see EN ISO 13849-1.

Risk assessment

The results of a risk assessment performed on the robot and its intended application may determine that a safety-related control system performance other than that stated in ISO 10218 is warranted for the application.

The SISTEMA/ABB FSDT libraries contains details for the safety functions.

Performance level for OmniCore C30 for CRB 15000

The OmniCore C30 for CRB 15000 controller safety system has a safety *category 3* with performance level *PL d* according to EN ISO 13849-1:2015 and thus fulfils the safety performance requirement of the robot safety standard EN ISO 10218-1:2011.

Safety data for SafeMove function - OmniCore C30 for CRB 15000

	SafeMove functions	Category (SRP/CS)	PFH _D (SRP/CS) [1/hour]	PL	Equiv. PFH _D (incl. brake) ⁱ [1/hour]
1	Enabling function	3	2.22x10 ⁻⁷	d	3.70x10 ⁻⁷
2	Emergency stop	3	2.31x10 ⁻⁷	d	3.79x10 ⁻⁷
3a	Protective stop (discrete)	3	2.40x10 ⁻⁷	d	3.88x10 ⁻⁷
3b	Protective stop (safe bus)	3	2.51x10 ⁻⁷	d	3.99x10 ⁻⁷
4	Category 0 stop	3	2.51x10 ⁻⁷	d	3.99x10 ⁻⁷
5	Monitored category 1 stop	3	2.66x10 ⁻⁷	d	4.14x10 ⁻⁷
6	Axis Position Supervision	3	2.66x10 ⁻⁷	d	4.14x10 ⁻⁷
7	Axis Speed Supervision	3	2.66x10 ⁻⁷	d	4.14x10 ⁻⁷
8	Stand Still Supervision	3	2.66x10 ⁻⁷	d	4.14x10 ⁻⁷
9	Tool Position Supervision	3	2.66x10 ⁻⁷	d	4.14x10 ⁻⁷

Continues on next page

2 Manipulator description

2.3 Safety data

Continued

	SafeMove functions	Category (SRP/CS)	PFH _D (SRP/CS) [1/hour]	PL	Equiv. PFH _D (incl. brake) ⁱ [1/hour]
10	Tool Orientation Supervision	3	2.66x10 ⁻⁷	d	4.14x10 ⁻⁷
11	Tool Speed Supervision	3	2.66x10 ⁻⁷	d	4.14x10 ⁻⁷
12	TCP Force Supervision	3	2.74x10 ⁻⁷	d	4.22x10 ⁻⁷
13	Axis Torque Supervision	3	2.74x10 ⁻⁷	d	4.22x10 ⁻⁷
14	Safe Payload Supervision	3	2.74x10 ⁻⁷	d	4.22x10 ⁻⁷
15	Control Error Supervision	3	2.66x10 ⁻⁷	d	4.14x10 ⁻⁷
16	Contact Application Tolerance	3	2.66x10 ⁻⁷	d	4.14x10 ⁻⁷

ⁱ Calculated using $PFH_{\text{Brake}} = 1 / (MTTF_{\text{Brake}} (\text{years}) \times 8760 \text{ hours/year})$. This is formally inconsistent with ISO 13849-1 but gives a realistic estimation of the risk reduction provided by the safety functions.



Note

All safety functions comply with ISO 10218-1: the SRP/CS achieves Category 3, PL d.

The Cyclic Brake Check must be run every 8-48 hours. For more details see [Running the Cyclic Brake Check routine on page 198](#).



Note

For the manipulator, all the safety functionality is included in the joint units. These are only designed to be replaced as complete units (see section [Repair on page 201](#)). Individual subcomponents shall not be exchanged.

The maximum communication and manipulator reaction times must be added to the reaction times from SafeMove (see *Application manual - Functional safety and SafeMove*).

- For stopping functions: 4 ms
- For position and torque monitoring functions: 6 ms
- Brake closing time <110 ms



Note

A violation of the standstill monitoring will result in a Category 0 stop (see ISO 10218-1 §5.5.3). Due to the brake closing time, the robot can fall some distance before it stops. Sufficient space must be provided around the robot to prevent an operator from being trapped. The falling distance and maximum speed are dependent on the robot pose, so this must be validated.

2.4 Working range

Illustration, working range CRB 15000-5/0.95

This illustration shows the unrestricted working range of the robot.

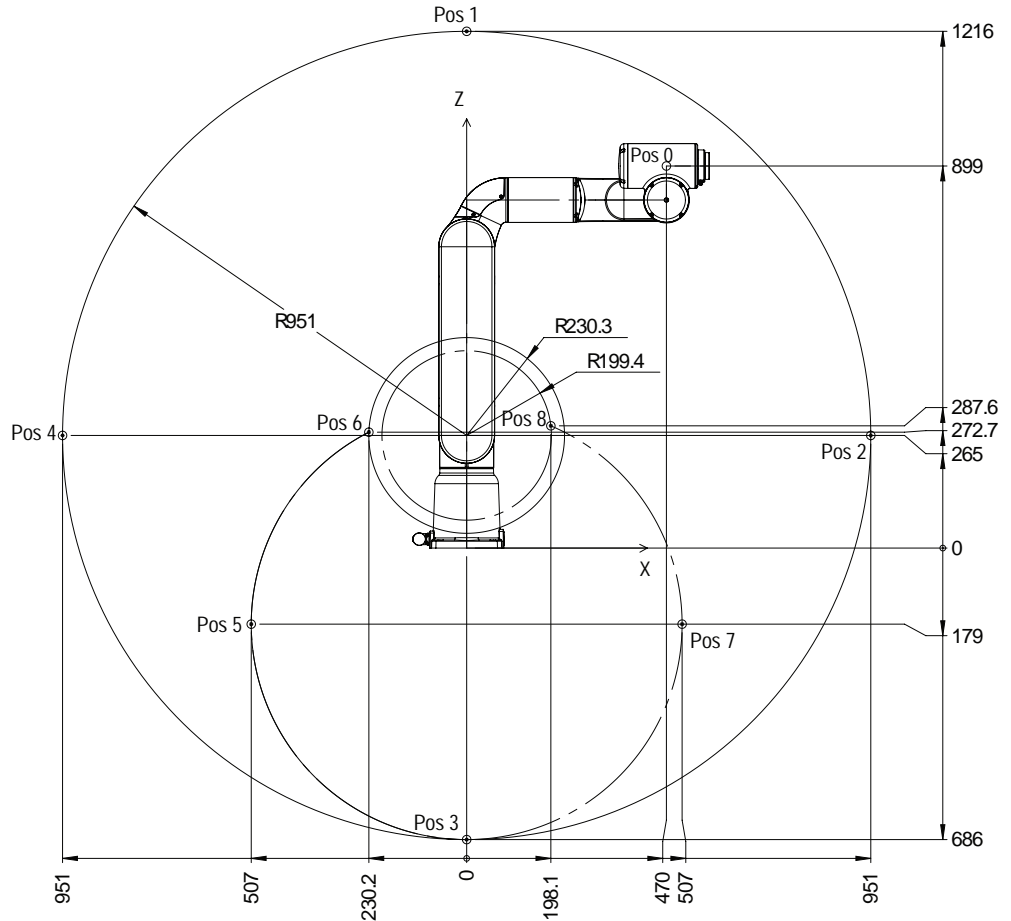

xx2000002410

Positions at intersection point of axes 4-5-6 and angle of axes 2 and 3

Position in the figure	Positions at wrist center (mm)		Angle (degrees)		
	X	Z	axis 2	axis 3	axis 5
pos0	470	899	0°	0°	0°
pos1	0	1216	0°	-68°	0°
pos2	951	265	90°	-68°	0°
pos3	0	-686	180°	-68°	0°
pos4	-951	265	-90°	-68°	0°
pos5	-507	-179	180°	22°	0°
pos6	-230.2	272.7	180°	85°	0°
pos7	507	-179	180°	-158°	0°
pos8	198.1	287.6	180°	-225°	0°

Continues on next page

2 Manipulator description

2.4 Working range

Continued

Illustration, working range CRB 15000-10/1.52

This illustration shows the unrestricted working range of the robot.

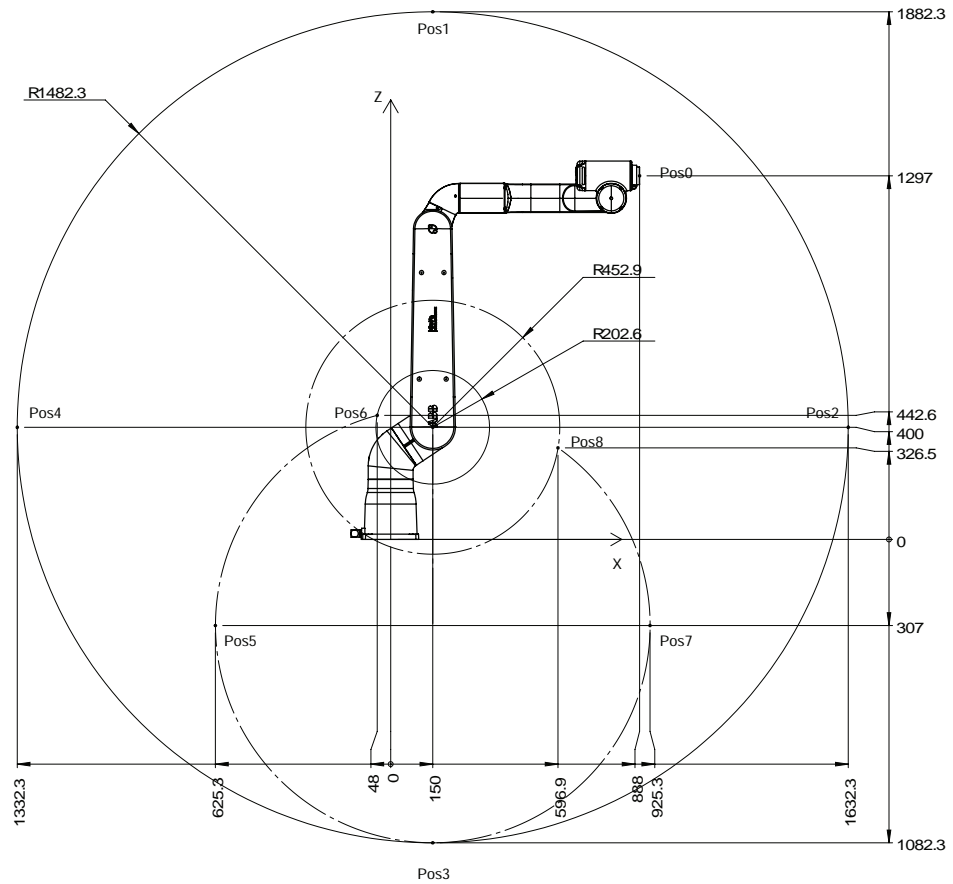

xx2300000575

Positions at wrist center and angle of axes 2 and 3

Position in the figure	Positions at wrist center (mm)		Angle (degrees)		
	X	Z	axis 2	axis 3	axis 5
pos0	888	1297	0°	0°	0°
pos1	150	1882.3	0°	-80.2°	28.58°
pos2	1632.3	400	90°	-80.2°	28.58°
pos3	150	-1082.3	180°	-80.2°	28.58°
pos4	-1332.3	400	-90°	-80.2°	28.58°
pos5	-625.3	-307	180°	9.8°	28.58°
pos6	-48	442.6	180°	85°	
pos7	925.3	-307	180°	-170.2°	28.58°
pos8	596.9	326.5	180°	-225°	28.58°

Continues on next page

Illustration, working range CRB 15000-12/1.27

This illustration shows the unrestricted working range of the robot.

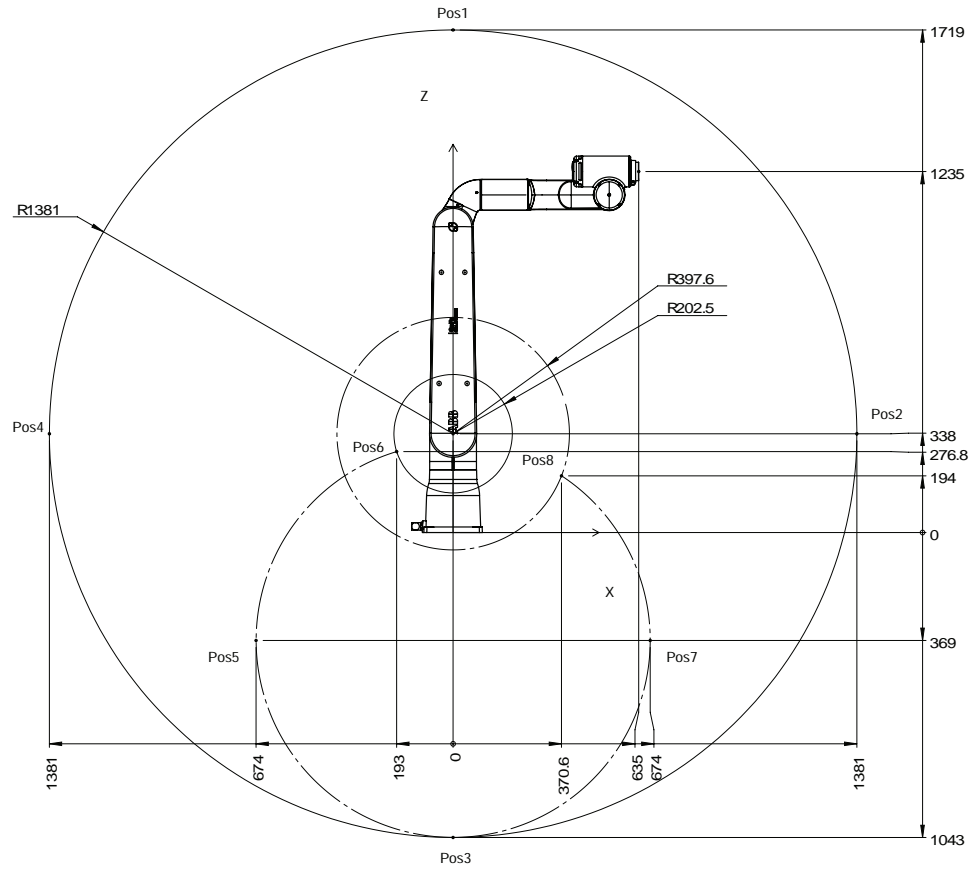

xx2300000576

Positions at wrist center and angle of axes 2 and 3

Position in the figure	Positions at wrist center (mm)		Angle (degrees)		
	X	Z	axis 2	axis 3	axis 5
pos0	635	1235	0°	0°	0°
pos1	0	1719	0°	-78.4°	26.7°
pos2	1381	338	90°	-78.4°	26.7°
pos3	0	-1043	180°	-78.4°	26.7°
pos4	-1381	338	-90°	-78.4°	26.7°
pos5	-674	-369	180°	11.6°	26.7°
pos6	-193	276.8	180°	85°	26.7°
pos7	674	-369	180°	-168.4°	26.7°
pos8	370.6	194	180°	-225°	26.7°

Continues on next page

2 Manipulator description

2.4 Working range

Continued

Top view of working range

CRB 15000-5/0.95

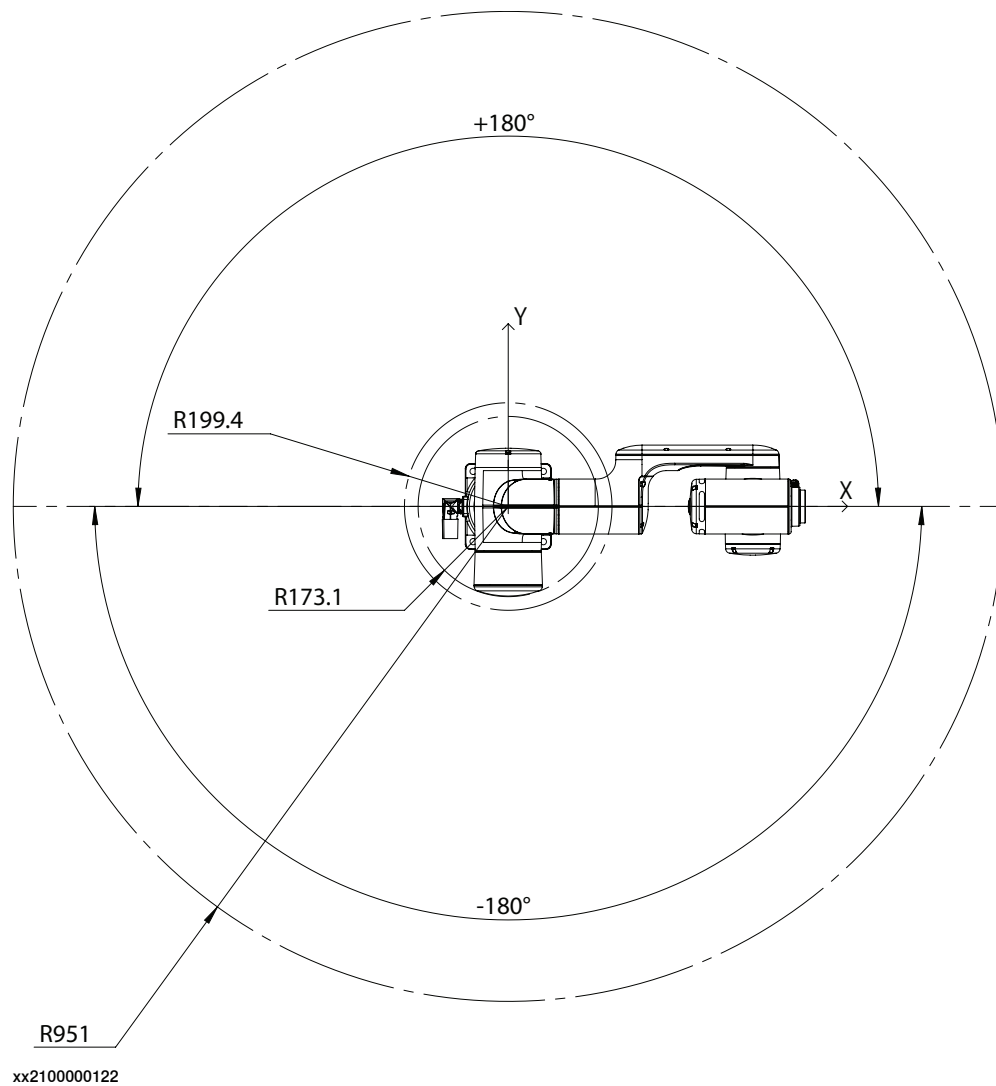

Continues on next page

CRB 15000-10/1.52

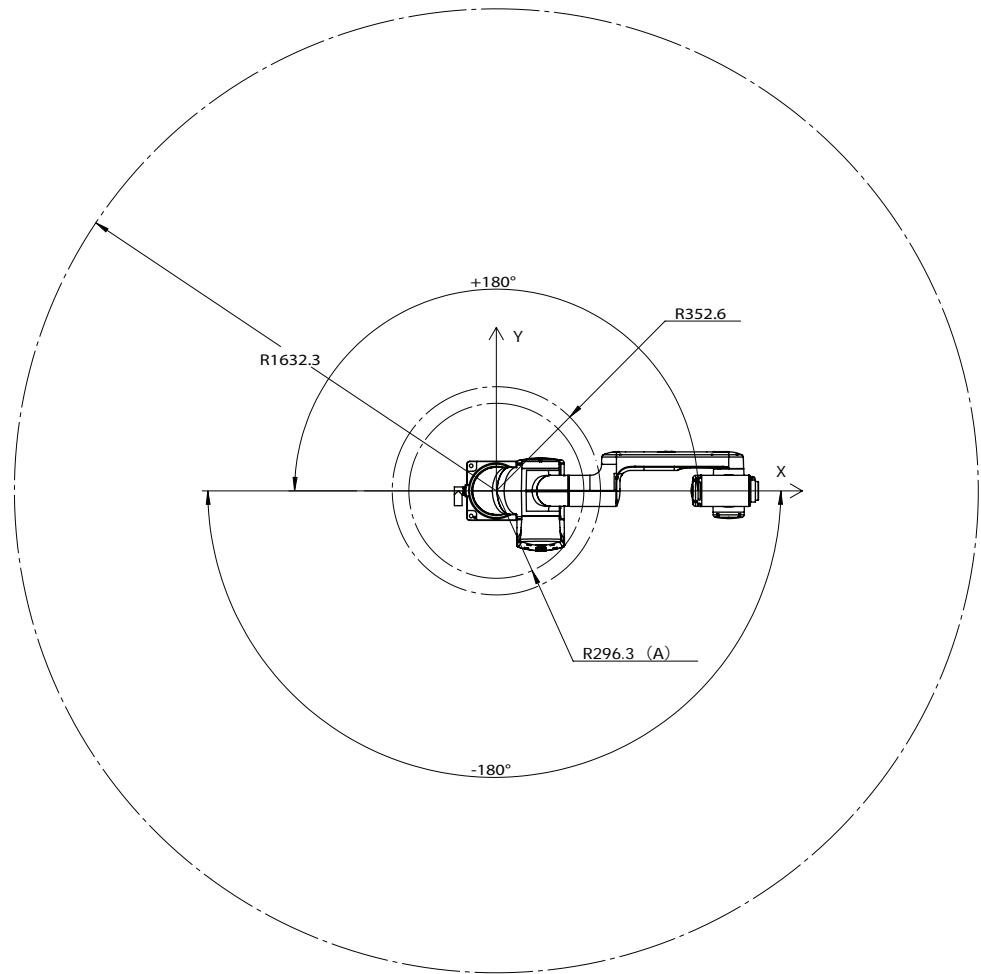

xx230000577

Continues on next page

2 Manipulator description

2.4 Working range

Continued

CRB 15000-12/1.27

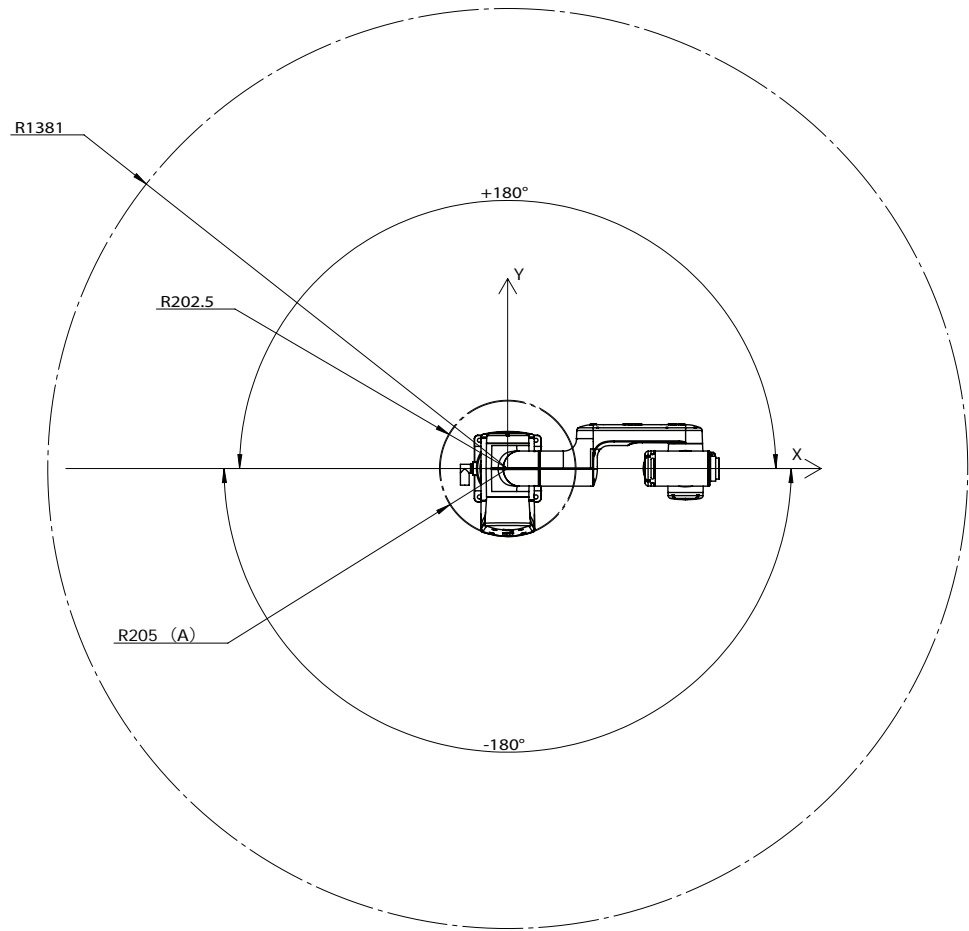

xx2300000578

Working range

Axis	Working range	Note
Axis 1	$\pm 180^\circ$ ⁱ / $\pm 270^\circ$ ⁱⁱ	Wall mounted robot has a work area for axis 1 that depends on payload and the positions of other axes. Simulation in RobotStudio is recommended.
Axis 2	$\pm 180^\circ$	
Axis 3	$-225^\circ / +85^\circ$	
Axis 4	$\pm 180^\circ$	
Axis 5	$\pm 180^\circ$	
Axis 6	$\pm 270^\circ$	

ⁱ Valid for CRB 15000-5/0.95.

ⁱⁱ Valid for CRB 15000-10/1.52 and CRB 15000-12/1.27.

2.5 The unit is sensitive to ESD

Description

ESD (electrostatic discharge) is the transfer of electrical static charge between two bodies at different potentials, either through direct contact or through an induced electrical field. When handling parts or their containers, personnel not grounded may potentially transfer high static charges. This discharge may destroy sensitive electronics.

Safe handling

Use one of the following alternatives:

- Use a wrist strap.

Wrist straps must be tested frequently to ensure that they are not damaged and are operating correctly.

- Use an ESD protective floor mat.

The mat must be grounded through a current-limiting resistor.

- Use a dissipative table mat.

The mat should provide a controlled discharge of static voltages and must be grounded.

This page is intentionally left blank

3 Installation and commissioning

3.1 Introduction to installation and commissioning

General

This chapter contains assembly instructions and information for installing the CRB 15000 at the working site.

See also the product manual for the robot controller.

The installation must be done by qualified installation personnel in accordance with the safety requirements set forth in the applicable national and regional standards and regulations.

The technical data is detailed in section [Technical data on page 40](#).

Safety information

Before any installation work is commenced, all safety information must be observed. There are general safety aspects that must be read through, as well as more specific safety information that describes the danger and safety risks when performing the procedures. Read the chapter [Safety on page 17](#) before performing any installation work.



Note

Always connect the CRB 15000 and the robot to protective earth and residual current device (RCD) before connecting to power and starting any installation work.

For more information see:

- *Product manual - OmniCore C30*

3 Installation and commissioning

3.2.1 Pre-installation procedure

3.2 Unpacking

3.2.1 Pre-installation procedure

Introduction

This section is intended for use when unpacking and installing the robot for the first time. It also contains information useful during later re-installation of the robot.

Prerequisites for installation personnel

Installation personnel working with an ABB product must:

- Be trained by ABB and have the required knowledge of mechanical and electrical installation/maintenance/repair work.
- Conform to all national and local codes.

Checking the pre-requisites for installation

	Action
1	Make a visual inspection of the packaging and make sure that nothing is damaged.
2	Remove the packaging.
3	Check for any visible transport damage.  Note Stop unpacking and contact ABB if transport damages are found.
4	Clean the unit with a lint-free cloth, if necessary.
5	Make sure that the lifting accessory used (if required) is suitable to handle the weight of the robot as specified in: Weight, robot on page 40
6	If the robot is not installed directly, it must be stored as described in: Storage conditions, robot on page 43
7	Make sure that the expected operating environment of the robot conforms to the specifications as described in: Operating conditions, robot on page 43
8	Before taking the robot to its installation site, make sure that the site conforms to: <ul style="list-style-type: none">• Loads on foundation, robot on page 40• Protection classes, robot on page 43• Requirements, foundation on page 42
9	Before moving the robot, please observe the stability of the robot: Risk of tipping/stability on page 57
10	When these prerequisites are met, the robot can be taken to its installation site as described in section: On-site installation on page 60
11	Install required equipment, if any.

3.2.2 Risk of tipping/stability

Risk of tipping

CRB 15000-5/0.95 is delivered lying flat in the delivery package, while CRB 15000-10/1.52 and CRB 15000-12/1.27 are delivered in standing position in the package. The robot cannot stand on its own without being secured to the foundation. If the robot can not be fastened to the foundation directly, store it in the delivery package.

Do not change the robot position before securing it to the foundation!

Transportation and shipping position

The figures show the robot in its shipping position, which also is a recommended transportation position.

CRB 15000-5/0.95

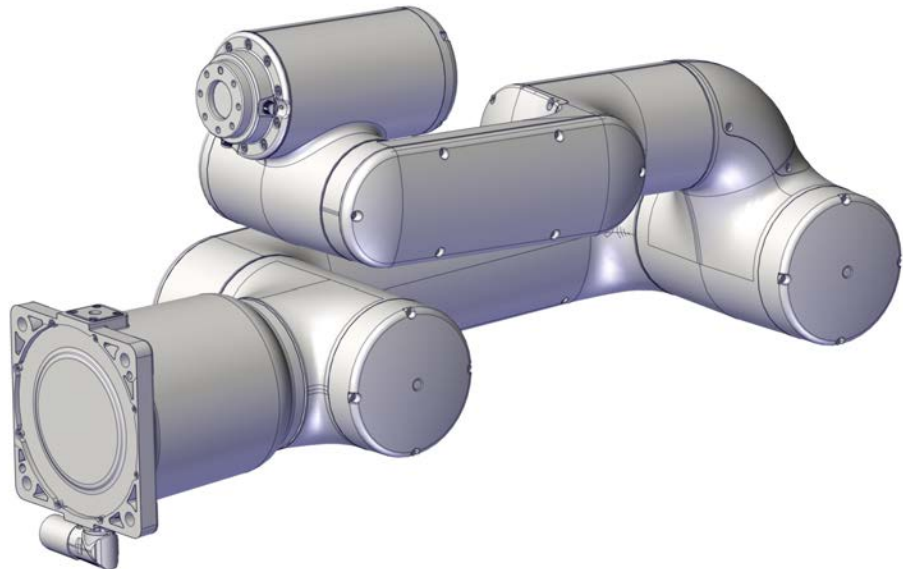

xx210000115

Axis 1	0°
Axis 2	0°
Axis 3	+85°
Axis 4	0°
Axis 5	0°
Axis 6	0°

Continues on next page

3 Installation and commissioning

3.2.2 Risk of tipping/stability

Continued

CRB 15000-10/1.52

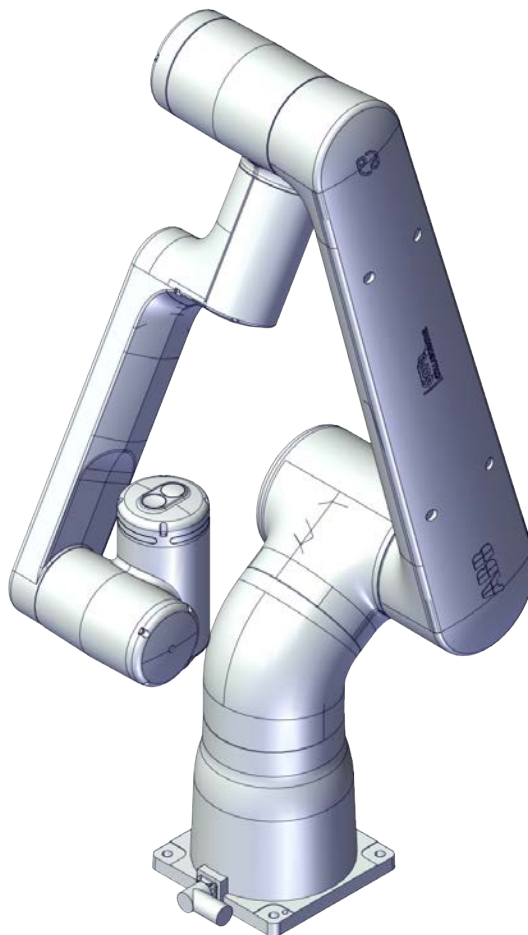

xx2300000380

Axis 1	0°
Axis 2	-15°
Axis 3	-225°
Axis 4	0°
Axis 5	-30°
Axis 6	0°

Continues on next page

CRB 15000-12/1.27

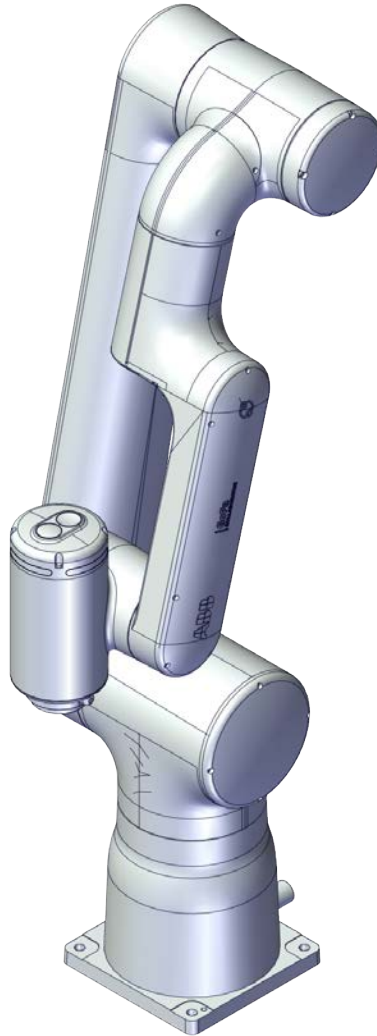

xx2300000381

Axis 1	0°
Axis 2	-10°
Axis 3	+85°
Axis 4	0°
Axis 5	+15°
Axis 6	0°



WARNING

The robot is mechanically unstable if not secured to the foundation.

3 Installation and commissioning

3.3.1 Brief installation procedure

3.3 On-site installation

3.3.1 Brief installation procedure

Introduction

This procedure is a brief guide when installing the robot for the first time. Also see [Pre-installation procedure on page 56](#).

First installation

Use these procedures to install the CRB 15000.

	Action	Note
1	Transport the manipulator to its intended location.	
2	Install the valid platform or prepare the foundation for the manipulator.	
3	Lift and secure the manipulator to the platform/foundation.	See Lifting the robot on page 61 . See Orienting and securing the robot on page 61 .
4	Connect the manipulator to the controller.	See <ul style="list-style-type: none">• Product manual - OmniCore C30
5	Configure the safety settings.	See <ul style="list-style-type: none">• Product manual - OmniCore C30
6	How to start and run the robot is described in the product manual for the controller.	See <ul style="list-style-type: none">• Product manual - OmniCore C30
7	Install required equipment, if any. <ul style="list-style-type: none">• Installation of brake release tool on page 75	
8	 DANGER Make sure all safety requirements are met when performing the first test run. See Test run after installation, maintenance, or repair on page 90 .	



Note

Wait till the robot has reached room temperature before switching on the mains power. Otherwise there might be a risk of condensation on internal components such as electronics.

3.3.2 Lifting the robot

3.3.2.1 Orienting and securing the robot

Introduction

This section describes how to lift the robot and transport it to the installation site. For CRB 15000-5/0.95, two persons are always required when lifting and securing the robot. For CRB 15000-10/1.52 and CRB 15000-12/1.27, lifting accessories, such as lifting roundslings, shall be prepared for the lifting and securing.

Do not leave the robot standing unfastened to the foundation, it is not stable on its own.



CAUTION

The manipulator must not be connected to power during lifting and securing it to the foundation.

Attachment screws

The table below specifies the type of securing screws and washers to be used for securing the robot to the base plate/foundation.

All hardware is enclosed in the robot delivery.

Suitable screws	M10x35
Quantity	4 pcs
Quality	8.8
Suitable washer	23/10.5/2.5 mm Steel
Guide pins	DIN6325, hardened steel Ø6x24 mm, 2 pcs
Tightening torque	32 Nm ±10%
Length of thread engagement	Minimum 15 mm for ground with material yield strength 150 MPa
Level surface requirements	0.1/500 mm

Continues on next page

3 Installation and commissioning

3.3.2.1 Orienting and securing the robot

Continued

Hole configuration, base

CRB 15000-5/0.95

This illustration shows the hole configuration used when securing CRB 15000-5/0.95.

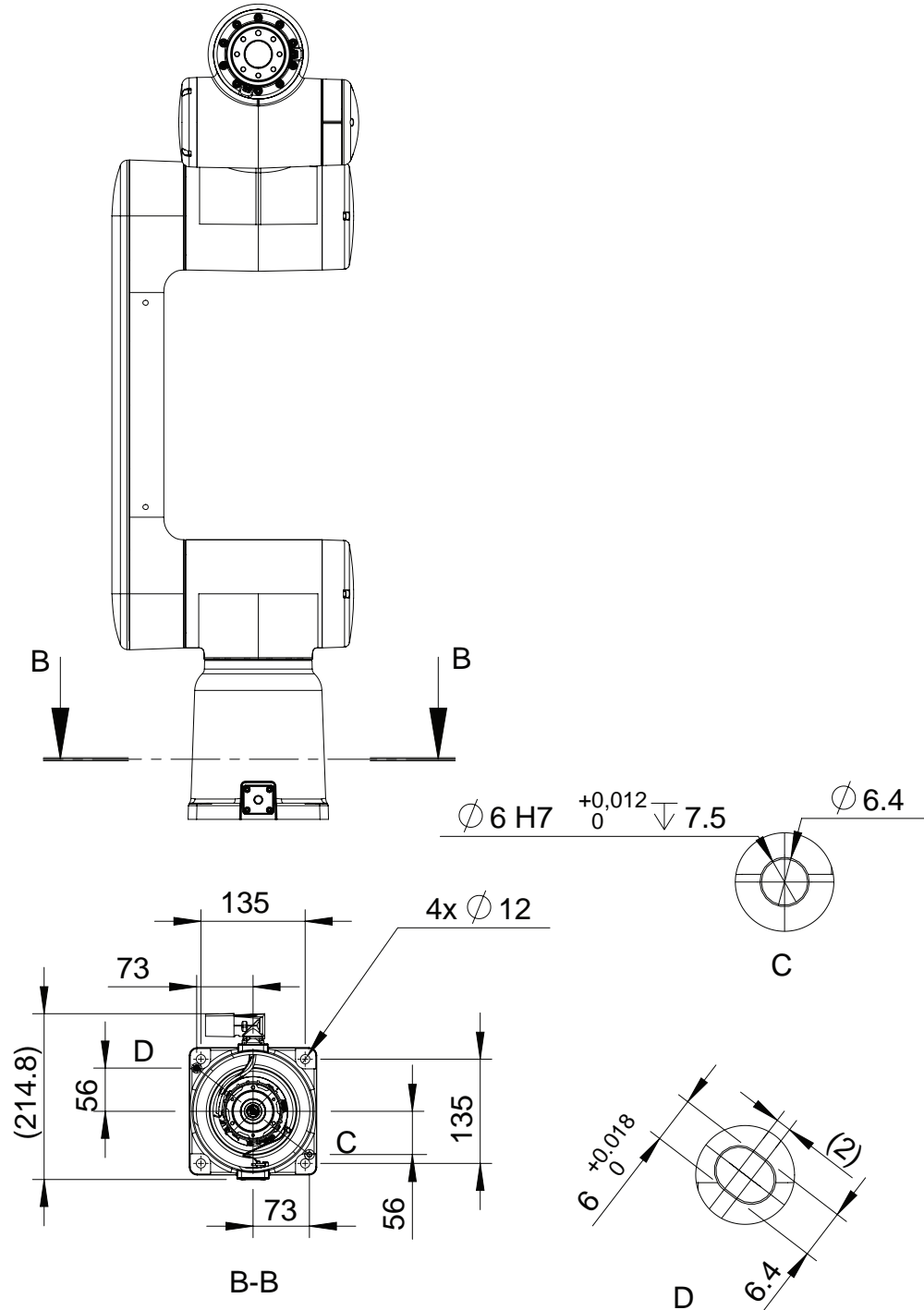

xx2000002366

C	Circular hole for locating pin
D	Elongated hole for locating pin

Continues on next page

3 Installation and commissioning

3.3.2.1 Orienting and securing the robot

Continued

CRB 15000-10/1.52

This illustration shows the hole configuration used when securing CRB 15000-10/1.52.

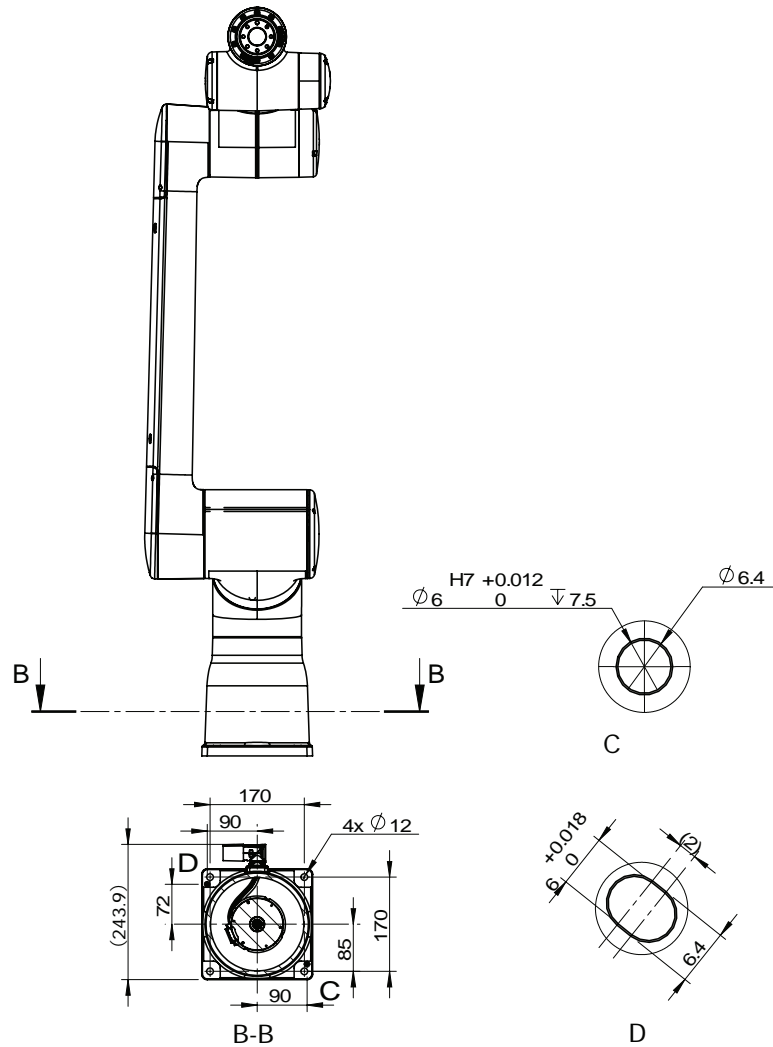

xx2300000382

C	Circular hole for locating pin
D	Elongated hole for locating pin

Continues on next page

3 Installation and commissioning

3.3.2.1 Orienting and securing the robot

Continued

CRB 15000-12/1.27

This illustration shows the hole configuration used when securing CRB 15000-12/1.27.

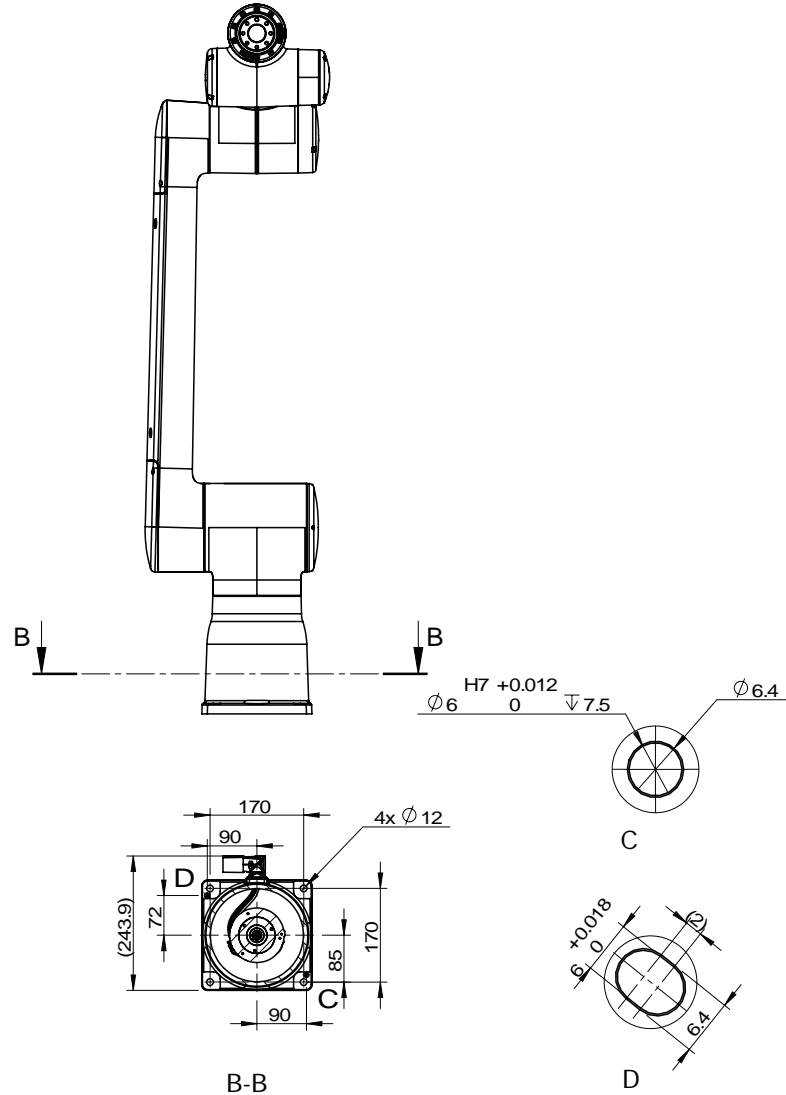

xx2300000383

C	Circular hole for locating pin
D	Elongated hole for locating pin

Lifting and securing the robot

Use this procedure to lift and secure the robot to its foundation.

Preparations of the installation site

	Action	Note
1	Make sure the installation site for the robot conforms to the specifications in section Technical data on page 40 .	

Continues on next page



3 Installation and commissioning

3.3.2.1 Orienting and securing the robot

Continued

	Action	Note
2	Prepare the installation site with attachment holes.	The hole configuration of the base is shown in Hole configuration, base on page 62 .
3	Valid for CRB 15000-10/1.52 and CRB 15000-12/1.27 Prepare the lifting roundsling.	Length: 2 m Lifting capacity: >100 kg

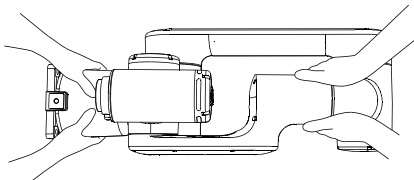
Lifting and securing the robot (-5/0.95)

	Action	Note
1	 CAUTION The CRB 15000 robot weighs 28 kg. A minimum of two persons are required for lifting as well as securing the robot in order to avoid any damage, instability, and injury. Special consideration is necessary when mounting the robot in an elevated, suspended or wall mounted position.	
2	Grasp the robot at the foot and elbow, as shown in the figure, and lift it up from the transportation package.	 xx2100000118
3	Carry the robot to the installation site.  CAUTION Do not leave the robot standing unfastened to the foundation, it is not stable on its own.	
4	Fit two pins to the holes in the base.	Centering pins: DIN6325, hardened steel Ø6x24 mm, 2 pcs .
5	Raise the robot to standing and secure to foundation, paying attention to the centering holes at the bottom of the robot base. <ul style="list-style-type: none"> • Person 1: keep holding the robot stable. • Person 2: secure the robot base to the foundation with the securing screws and washers. 	Screws: M10x35, 4 pcs, quality 8.8 Washers: 23/10.5/2.5 mm Steel
6	Tighten the bolts in a crosswise pattern to ensure that the base is not distorted.	Tightening torque: 32 Nm ±10%



Continues on next page

3 Installation and commissioning

3.3.2.1 Orienting and securing the robot

Continued

Lifting and securing the robot (-10/1.52 and -12/1.27)



	Action	Note
1	<p>Make sure the robot is positioned in the recommended position for transportation and lifting.</p> <p> WARNING</p> <p>The robot is mechanically unstable if not secured to the foundation.</p>	<p>Recommended position for transportation and lifting is shown in Transportation and shipping position on page 57.</p>
2	<p> CAUTION</p> <p>The weight of the CRB 15000 robot is up to 51 kg</p> <p>All lifting accessories used must be sized accordingly.</p>	

Continues on next page

3 Installation and commissioning

3.3.2.1 Orienting and securing the robot

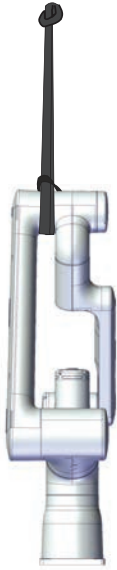
Continued

	Action	Note
3	<p>Attach the roundslings to the robot according to the figure.</p> <p>Make sure the roundslings do not rub against any sharp edges.</p>	<p>CRB 15000-10/1.52</p>  <p>xx2300000384</p> <p>CRB 15000-12/1.27</p>  <p>xx2300000385</p>
4	<p> WARNING</p> <p>Personnel must not, under any circumstances, be present under the suspended load.</p>	
5	<p>Raise the overhead crane to lift the robot.</p>	

Continues on next page

3 Installation and commissioning

3.3.2.1 Orienting and securing the robot

Continued

	Action	Note
6	<p>Move the robot to the installation site.</p> <p> CAUTION</p> <p>Do not leave the robot standing unfastened to the foundation, it is not stable on its own.</p>	
7	<p>Fit two pins to the holes in the base.</p>	<p>Centering pins: DIN6325, hardened steel Ø6x24 mm, 2 pcs .</p>
8	<p>Guide the robot gently, using the attachment screws while lowering it into its mounting position.</p>	<p>Make sure the robot base is correctly fitted onto the pins.</p>
9	<p>Fit the securing screws and washers in the attachment holes of the base.</p>	<p>Screws: M10x35, 4 pcs, quality 8.8 Washers: 23/10.5/2.5 mm Steel</p>
10	<p>Tighten the bolts in a crosswise pattern to ensure that the base is not distorted.</p>	<p>Tightening torque: 32 Nm ±10%</p>

3.3.3 Manually releasing the brakes

Introduction to manually releasing the brakes

This section describes how to release the holding brakes for the axes motors using the FlexPendant.

To fulfill ISO 10218-1:2011 5.13 Movement without drive power, a FlexPendant must be available on the site when using RobotWare 7.10 and higher.



CAUTION

On robots with RobotWare earlier than 7.10, the brakes are released using an external brake release tool, see [Manually releasing the brakes with the external tool on page 71](#).



DANGER

If there is no FlexPendant connected, or in a system failure state, the brake release function is not immediately available. Dangerous clamping situations should always be mitigated using safety functions, see the section [Configuring the software on page 114](#).



CAUTION

At least two persons should be present when releasing the brakes.

Releasing the brakes from the FlexPendant

Use this procedure to release the holding brakes using the FlexPendant.



Note

The manipulator needs to be powered and motors in state Motors OFF.

	Action	Note
1	Press the emergency stop. On the FlexPendant, a tab appears, Brake Release .	
2	Open the brake release window and select which brakes to release. Tap Request Brake Release . The LEDs on the arm-side interface starts blinking yellow.	See Arm-side interface on page 105 .
3	 DANGER When releasing the holding brakes, gravity can affect the robot so that the arm moves downwards quickly. Make sure that the arm is secured against collapsing under gravity and that no personnel is at risk of getting hit by the arm moving downwards.	

Continues on next page

3 Installation and commissioning

3.3.3 Manually releasing the brakes

Continued

	Action	Note
4	Press the enabling device halfway in within 30 seconds. This releases the brakes.	If the enabling device is not pressed in within 30 seconds, the brake release function will be cancelled.
5	Move the robot arm to a desired position.	
6	The brake will function again as soon as the enabling device is released.	When the enabling device is released or pressed fully in, then the brakes are activated immediately. To continue moving the arm freely, the brake release function must be restarted.

3.3.4 Manually releasing the brakes with the external tool

Introduction to manually releasing the brakes

This section describes how to release the holding brakes for the axes motors using an external brake release tool.



CAUTION

The external brake release tool works on robots with RobotWare earlier than 7.10. On robots with RobotWare 7.10 or later, the tool does not work.

How to release the brakes using the FlexPendant is described in section [Manually releasing the brakes on page 69](#).



CAUTION

At least two persons should be present when releasing the brakes.

Required equipment

Equipment	Article number	Note
Brake release tool	3HAC079146-001	<p>For releasing the holding brakes of a joint unit motor if the RobotWare version is 7.8 or older.</p> <p> Note</p> <p>The spare parts related to the brake release function using the external tool are discontinued from Q2 2023.</p>

Continues on next page

3 Installation and commissioning

3.3.4 Manually releasing the brakes with the external tool

Continued

Location of the brake release points

The brake release points are located on each axis as shown in the figure. The numbers correspond to the axis number.

The holding brake on axis 6 can not be released manually. If axis 6 needs to be moved, release the holding brake on another proper axis instead.

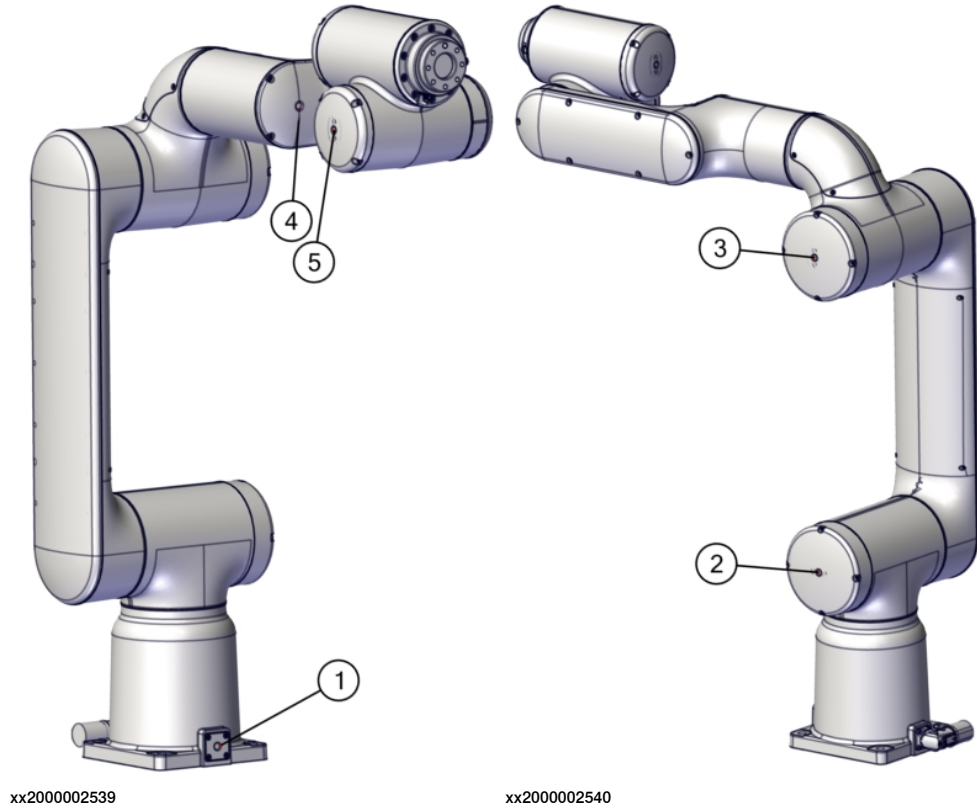

Releasing the brakes

This procedure describes how to release the holding brakes using the brake release tool.



Note



The manipulator needs to be powered and motors in state Motors OFF. Do not release the brakes in automatic operating mode.

Continues on next page

3 Installation and commissioning

3.3.4 Manually releasing the brakes with the external tool

Continued

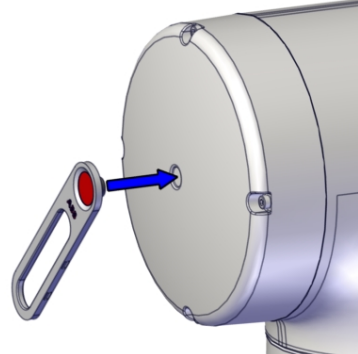
	Action	Note
1	Take out the tool from its holder.	Brake release tool: 3HAC079146-001  <small>xx2000002542</small>
2	 DANGER When releasing the holding brakes, gravity can affect the robot so that the arm moves downwards quickly. Make sure that the arm is secured against collapsing under gravity and that no personnel is at risk of getting hit by the arm moving downwards.	
3	Release the holding brake on a particular robot axis by holding the brake release tool against the small round recess at the axis. The brake will function again as soon as the tool is removed.	 <small>xx2000002538</small> The sensor behind the cover is triggered by the tool magnet and the corresponding motor holding brake will be released. If any faulty functionality is discovered, see Brake release tool does not work on page 1075 .
4	Put back the tool in its holder and store on specified location close to the robot.	

Continues on next page

3 Installation and commissioning

3.3.4 Manually releasing the brakes with the external tool

Continued

Supplying power to connector R1.MP

If the robot is not connected to the controller, power must be supplied to connector R1.MP on the robot, in order to enable the brake release sensors.

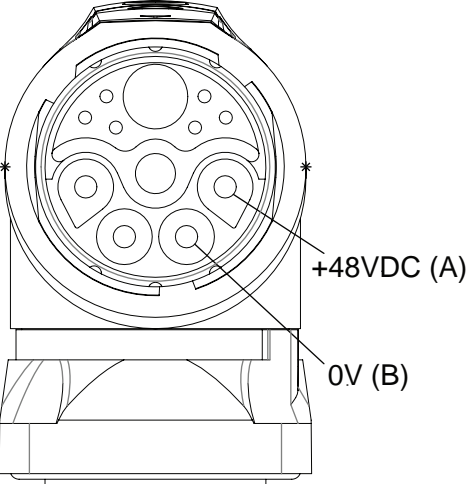
	Action	Note
1	<p> CAUTION</p> <p>Incorrect connections, such as supplying power to the wrong pin, may cause damage to the electrical components.</p>	
2	Supply 0V on pin B and +48VDC on pin A.	 <p>xx2100000124</p>

3.3.5 Installation of brake release tool

Brake release tool included in robot delivery

For robots delivered with RobotWare earlier than 7.10, a brake release tool is included in the robot package box. The tool is used for releasing the holding brakes of the axes motors.



CAUTION

The external brake release tool works on robots with RobotWare earlier than 7.10. On robots with RobotWare 7.10 or later, the tool does not work.

How to release the brakes using the FlexPendant is described in section [Manually releasing the brakes on page 69](#).

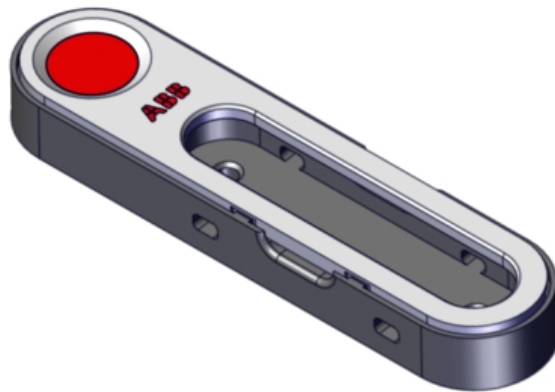

xx2000002541

Specify storage location

The brake release tool must be mounted or permanently stored close to the robot, for easy and quick access in case of emergency. The storage location must be well known for all personnel working with or nearby the robot.

Continues on next page

3 Installation and commissioning

3.3.5 Installation of brake release tool

Continued

Securing the brake release tool holder

Securing with screws

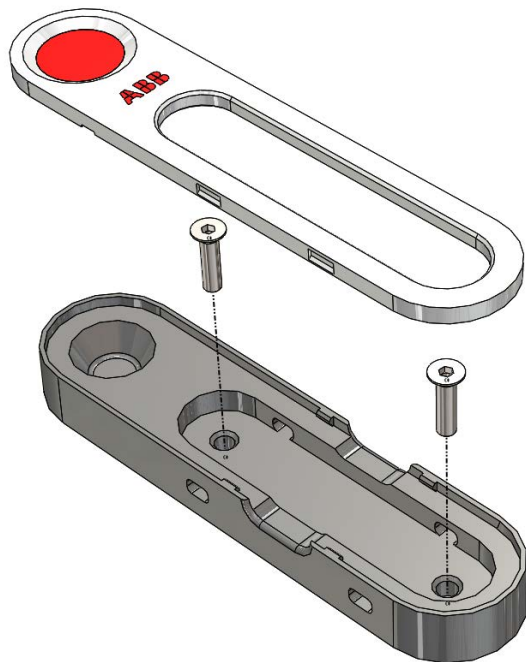

xx210000403

Securing with cable ties

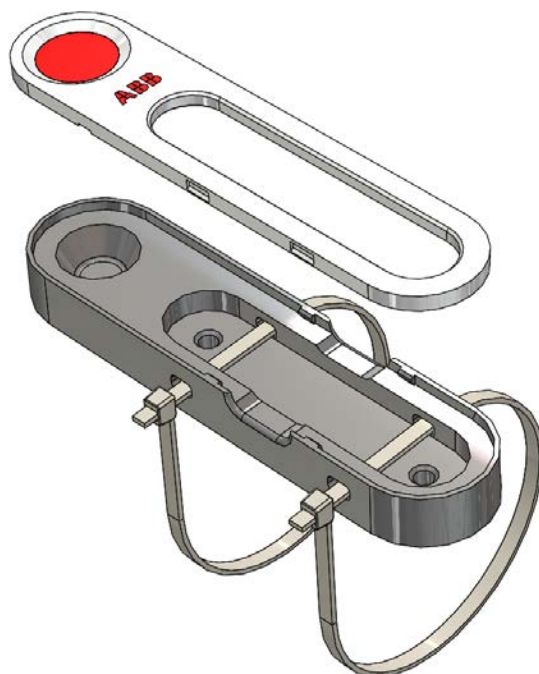

xx210000404

3.3.6 Setting the system parameters for an inverted or a tilted robot

General

The robot is configured for mounting parallel to the floor, without tilting, on delivery. If the robot is mounted in any other angle than 0° , then the system parameters that describe the mounting angle (how the robot is oriented relative to the gravity) must be re-defined.



Note

With inverted installation, make sure that the gantry or corresponding structure is rigid enough to prevent unacceptable vibrations and deflections, so that optimum performance can be achieved.



Note

The mounting positions are described in [Mounting positions on page 40](#), and the requirements on the foundation are described in [Requirements, foundation on page 42](#).

System parameters



Note

The mounting angle must be configured correctly in the system parameters so that the robot system can control the movements in the best possible way. An incorrect definition of the mounting angle will result in:

- Overloading the mechanical structure.
- Lower path performance and path accuracy.
- Some functions will not work properly, for example *Load Identification* and *Collision detection*.

Gravity Beta

When the robot is mounted other than floor-standing (rotated around the y-axis), the robot base frame and the system parameter *Gravity Beta* must be redefined. If the robot is mounted upside down (inverted), then *Gravity Beta* should be π (+3.141593).

If the robot is mounted on a wall, then *Gravity Beta* should be $\pm\pi/2$ (± 1.570796).

The *Gravity Beta* is a positive rotation direction around the y-axis in the base coordinate system. The value is set in radians.

Gravity Alpha

If the robot is mounted on a wall (rotated around the x-axis), then the robot base frame and the system parameter *Gravity Alpha* must be redefined. The value of *Gravity Alpha* should then be $\pm\pi/2$ (± 1.570796).

Continues on next page

3 Installation and commissioning

3.3.6 Setting the system parameters for an inverted or a tilted robot

Continued

The *Gravity Alpha* is a positive rotation direction around the x-axis in the base coordinate system. The value is set in radians.



Note

The system parameter *Gravity Alpha* is not supported for all robot types. If the robot does not support *Gravity Alpha*, then use *Gravity Beta* along with the re-calibration of axis 1 to define the rotation of the robot around the x-axis.



Note

The parameter is supported for all robots on track when the system parameter *7 axes high performance motion* is set, see *Technical reference manual - System parameters*.

Gamma Rotation

Gamma Rotation defines the orientation of the robot foot on the travel carriage (track motion).

Mounting angles and values

The parameter *Gravity Beta* (or *Gravity Alpha*) specifies the mounting angle of the robot in radians. It is calculated in the following way.

$\text{Gravity Beta} = A^\circ \times 3.141593/180 = B \text{ radians}$, where **A** is the mounting angle in degrees and **B** is the mounting angle in radians.

Example of position	Mounting angle (A °)	Gravity Beta
Floor mounted	0°	0.000000 (Default)
Wall mounted	90°	1.570796
Inverted mounting	180°	3.141593

Examples of mounting angles tilted around the X axis (*Gravity Alpha*)

The following illustration shows the IRB 120, but the same principle applies for all robots.

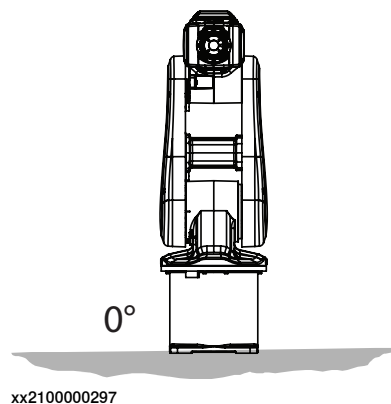

Continues on next page

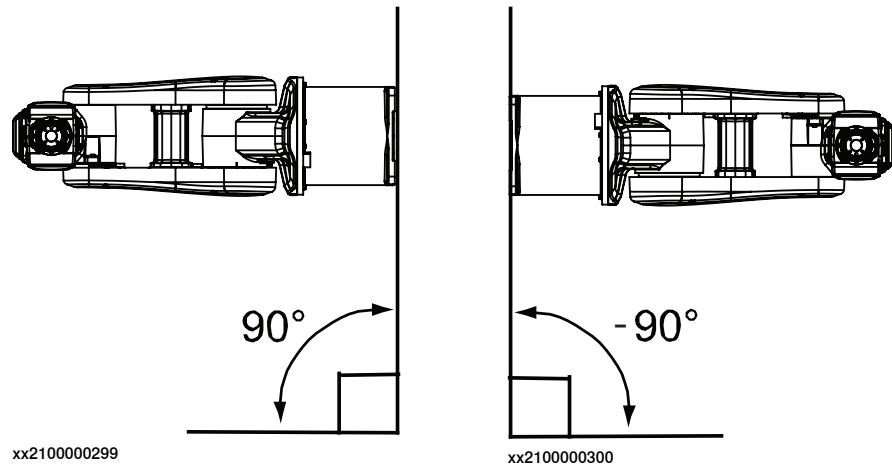

Mounting angle	Gravity Alpha
0° (Floor mounted)	0
90° (Wall)	1.570796
-90° (Wall)	-1.570796



Note

For suspended robots (180°), it is recommended to use *Gravity Beta* instead of *Gravity Alpha*.

Limitations in working area

If mounting the robot on a wall, the working range of axis 1 is limited. These limitations are specified in the table [Working range on page 52](#).

Defining the system parameters in RobotWare

The value of the system parameters that define the mounting angle must be redefined when changing the mounting angle of the robot. The parameters belong to the type *Robot*, in the topic *Motion*.

The system parameters are described in *Technical reference manual - System parameters*.

The system parameters are configured in RobotStudio or on the FlexPendant.

3 Installation and commissioning

3.3.7 Loads fitted to the robot, stopping time and braking distances

3.3.7 Loads fitted to the robot, stopping time and braking distances

Define loads carefully

Any loads mounted on the robot must be defined correctly and carefully (with regard to the position of center of gravity and mass moments of inertia) in order to avoid jolting movements and overloading motors, gears and structure.



CAUTION

Incorrectly defined loads may result in operational stops or major damage to the robot.

Load diagrams, permitted extra loads (equipment) and their positions are specified in the product specification. The loads must be defined in the software.

Stopping time and braking distances

The performance of the motor brake depends on if there are any loads attached to the robot.

See the product specification for the robot, listed in [References on page 10](#).

3.3.8 Fitting equipment on the robot (robot dimensions)



Note

Even after the robot is secured to the foundation, do not lean on it or place loads on it, except what is permitted on the tool flange.

Robot dimensions

The figure shows the dimension of the robot.

CRB 15000-5/0.95

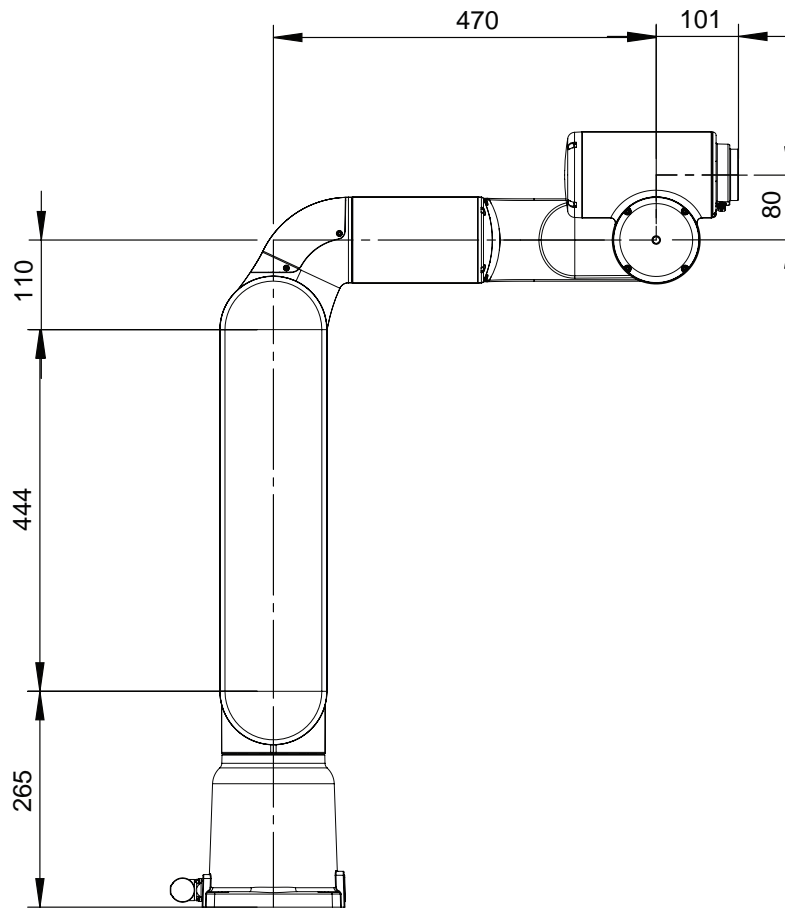

xx2000002368

Continues on next page

3 Installation and commissioning

3.3.8 Fitting equipment on the robot (robot dimensions)

Continued

CRB 15000-10/1.52

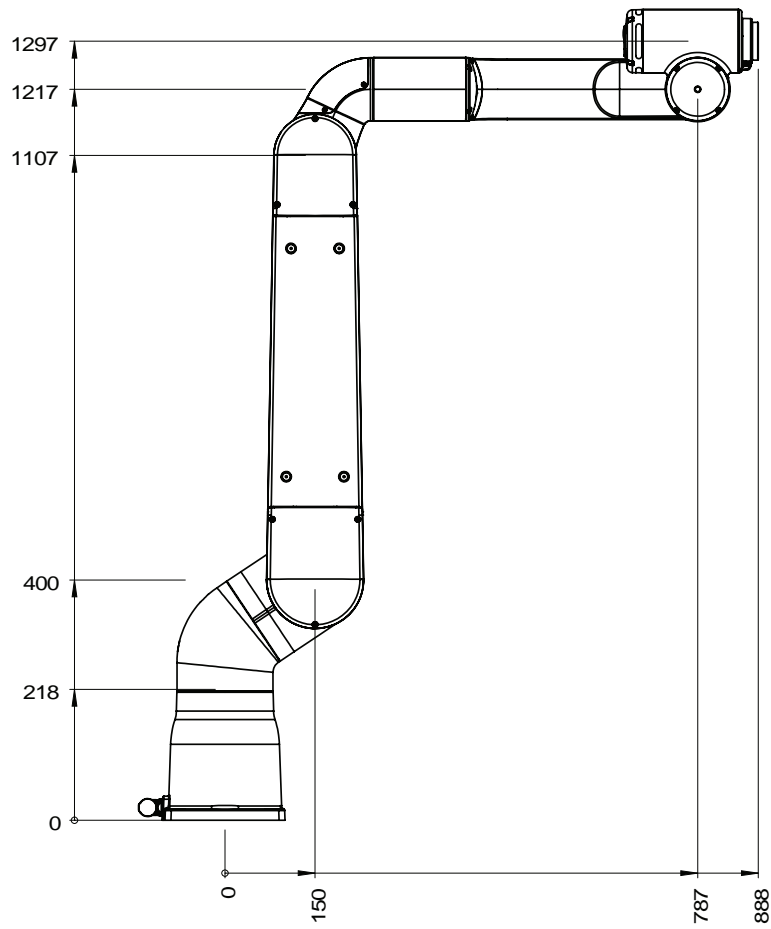

xx2300000646

Continues on next page

3 Installation and commissioning

3.3.8 Fitting equipment on the robot (robot dimensions)

Continued

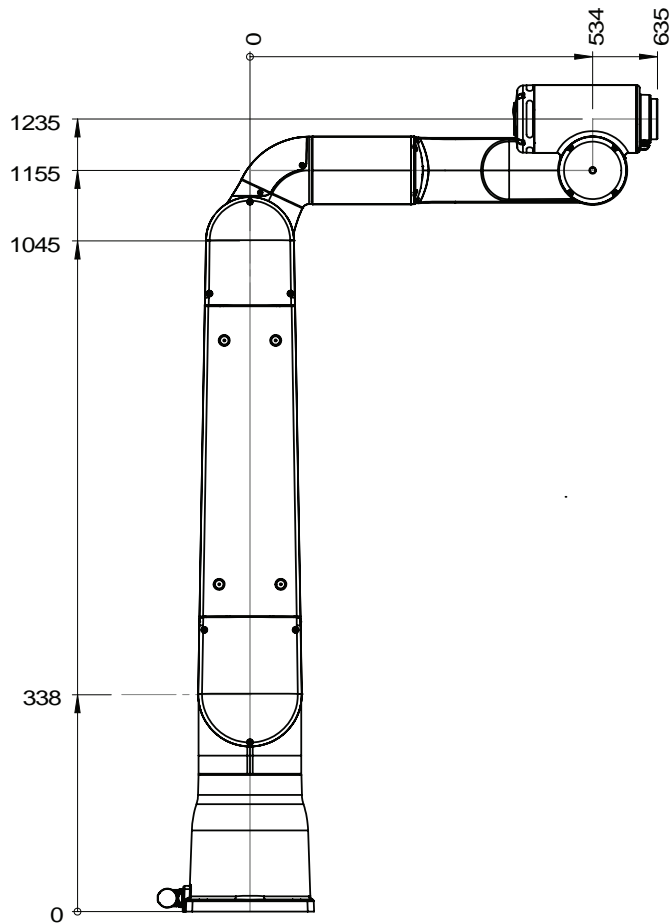

xx230000647

Fitting equipment on the robot arm



ELECTRICAL SHOCK

External cable routing where voltages deemed to be hazardous live, ground resistance path shall not exceed 0.1 ohms for all metal parts exposed or likely to be touched by a person during normal operation, and likely to become energized through electrical malfunction.

Continues on next page

3 Installation and commissioning

3.3.8 Fitting equipment on the robot (robot dimensions)

Continued

Upper arm

The robot upper arm is not designed with attachment holes for any arm load. However, for light loads such as cables, it is possible to mount them directly on the arm, or to replace the four screws on the upper arm cover with hex spacers, as shown in the following figure (taking CRB 15000-5/0.95 as an example).

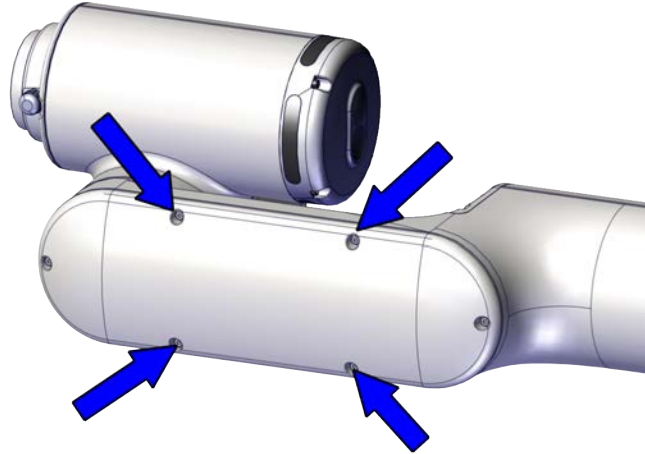

xx2300001024

Definitions of dimensions and masses are shown in [Holes for fitting extra equipment on page 85](#). Requirements on hex spacers are shown in [Fastener quality for hex spacers on page 88](#).



Note

Sharp edges or other hazards related to the hex spacers or fitted equipment must be taken into consideration.



Note

If the gasket screws on the upper arm cover of CRB 15000-5/0.95 are replaced with hex spacers, then the IP54 is no longer fulfilled.

Before fitting equipment to the robot upper arm, special considerations must be taken:

- Any external cable routing along the robot arm shall be done in a flexible way allowing for robot motion and taking hazards associated with entanglement into account.
- The brake release points on each axis must be accessible in the end application using the external brake release tool.

Continues on next page

Brake release points are shown in [Manually releasing the brakes on page 69](#).



CAUTION

The external brake release tool works on robots with RobotWare earlier than 7.10. On robots with RobotWare 7.10 or later, the tool does not work.

- The armload interface can handle loads up to 1 kg. This includes the weight of the cabling, tools, and workpiece (if lifted).



Note

When the arm load is defined, the maximum payload capacity may be reduced in certain poses. A simulation in RobotStudio shall be performed to verify that the combination of arm load and payload works in the intended application.

Housing and lower arm

For CRB 15000-10/1.52 and CRB 15000-12/1.27, robot housing and lower arm can also handle extra loads up to 1 kg respectively. Definitions of dimensions and masses are shown in [Holes for fitting extra equipment on page 85](#).

Maximum allowed arm load depends on center of gravity of arm load and robot payload. When an armload is attached, the payload on the wrist is reduced.

Holes for fitting extra equipment

Upper arm, CRB 15000-5/0.95

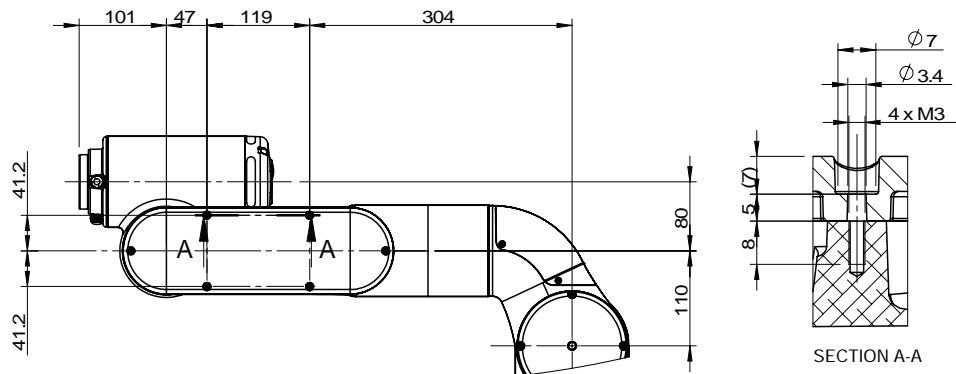

xx230000988

Continues on next page

3 Installation and commissioning

3.3.8 Fitting equipment on the robot (robot dimensions)

Continued

Upper arm, CRB 15000-10/1.52

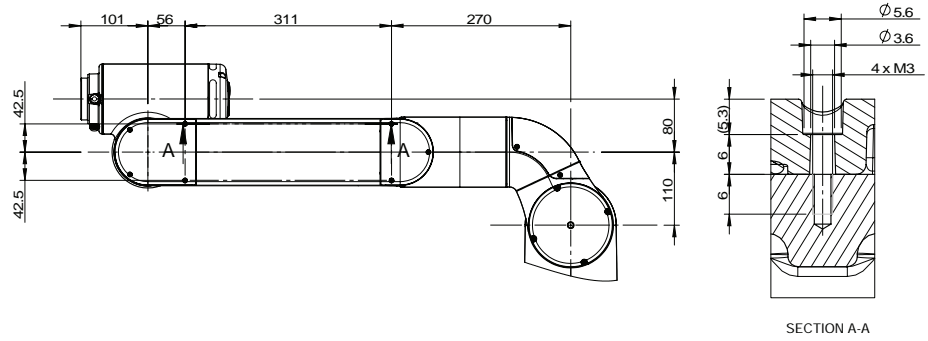

xx230000989

Upper arm, CRB 15000-12/1.27

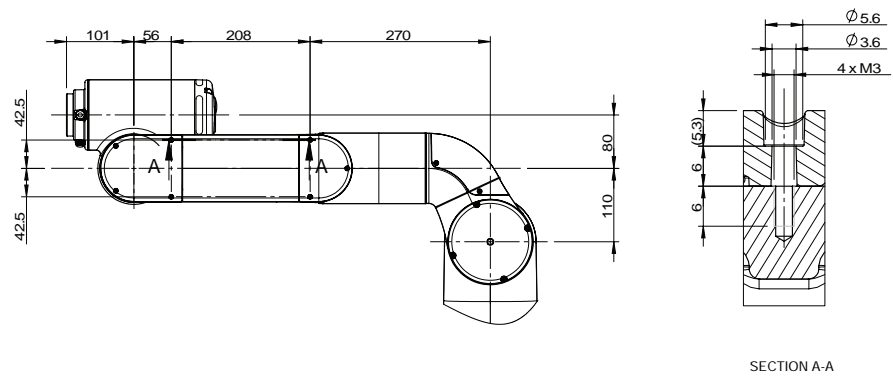

xx230000990

Continues on next page

3 Installation and commissioning

3.3.8 Fitting equipment on the robot (robot dimensions)

Continued

Housing and lower arm, CRB 15000-10/1.52

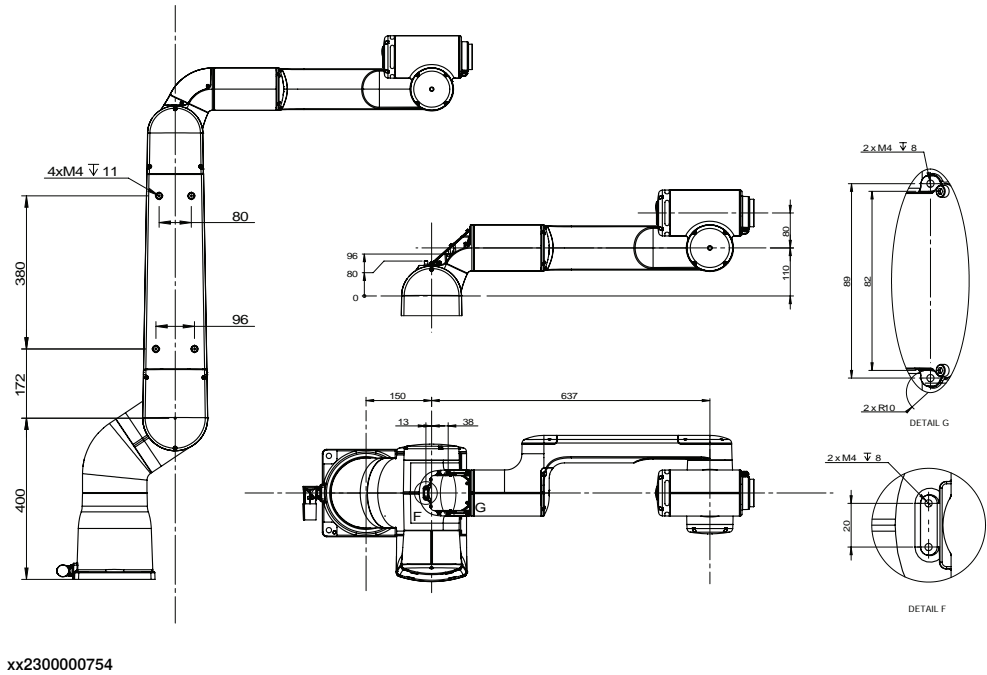

Housing and lower arm, CRB 15000-12/1.27

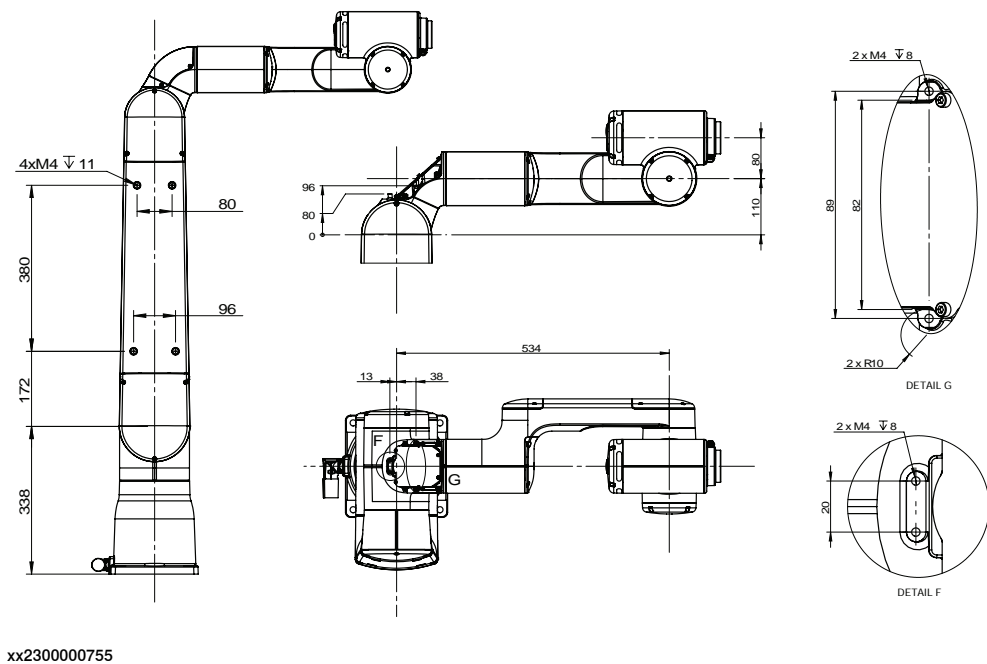

Continues on next page

3 Installation and commissioning

3.3.8 Fitting equipment on the robot (robot dimensions)

Continued

Fastener quality for hex spacers

The following table shows the requirements on hex spacers for fitting equipment on the upper arm covers.

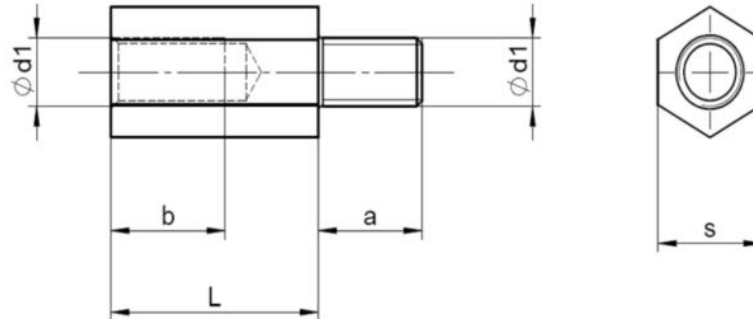

xx2300000930

	CRB 15000-5/0.95	CRB 15000-10/1.52 CRB 15000-12/1.27
Material	Stainless steel 4.8, or higher	Stainless steel 4.8, or higher
Tightening torque	0.6 Nm+/-5%	0.6 Nm+/-5%
Minimum thread length (a)	8 mm	10 mm
Thread length (b)	8 mm	10 mm
Screw head width (S)	5 mm	5 mm
Length (L)	18 mm	25 mm
Example of suitable hex spacer	Bossard, article number: 304318041152 Keystone, article number: 24289~24294	Bossard, article number: 304325041152 Bossard, article number: 304330041152

Continues on next page

Tool flange

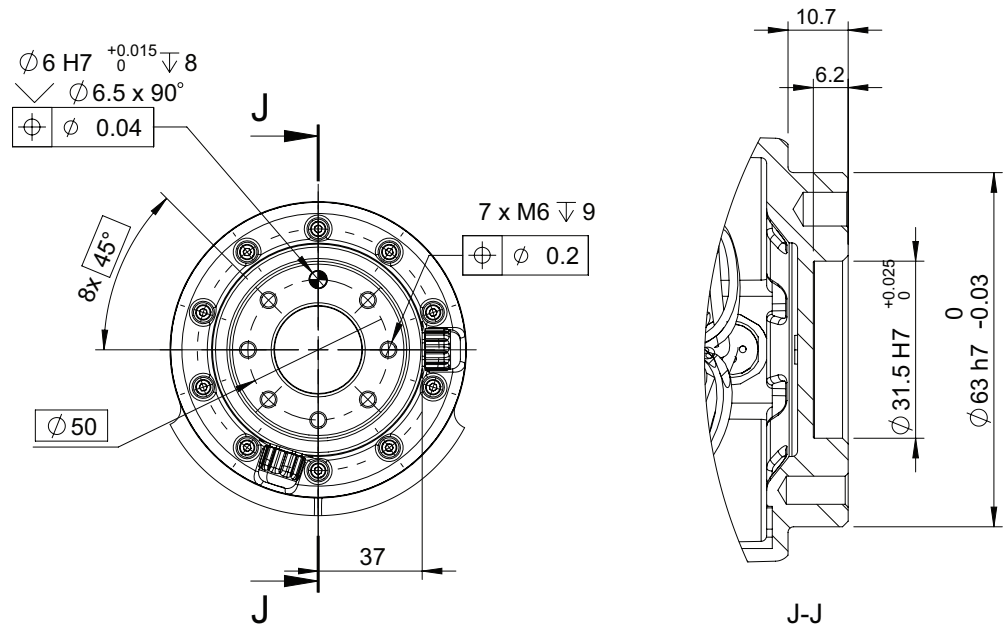

xx2000002367

Fastener quality on tool flange

Use screws with suitable length and tightening torque for your application.

Screws with quality class 12.9 are recommended.

Also note the thread depth on the tool flange. Using too long screws may damage the tool flange and cause the tool to be improperly fastened, which is a safety hazard.

3 Installation and commissioning

3.3.9 Test run after installation, maintenance, or repair

3.3.9 Test run after installation, maintenance, or repair

Safe handling

Use the following procedure after installation, maintenance, or repair, before initiating motion.



DANGER

Initiating motion without fulfilling the following aspects, may increase the risk for injury or cause damage to the robot.

	Action
1	Remove all tools and foreign objects from the robot and its working area.
2	Verify that the robot is properly secured to its position by all screws, before it is powered up.
3	Verify that any safety equipment installed to secure the position or restrict the robot motion during service activity is removed.
4	Verify that the fixture and work piece are well secured, if applicable.
5	Verify that the brake release tool is in its intended place.
6	Verify that no personnel is leaning on, or have their head or neck close to the robot.
7	Verify that all arm covers and paddings, if any, are properly secured to the robot.
8	If maintenance or repair has been done, verify the function of the part that was maintained.
9	Verify the application in the operating mode manual reduced speed.

3.3.10 Installation of laser scanner

Overview

The safety separation technology and speed control for CRB 15000 is based on the connection and communication of one or two safety laser scanners in the robot. Laser scanner(s) provides a timely and continuous monitor on the activities within its scanning area and forms a protective field. One laser scanner can provide a scanning range of approximately 275° . The system integrator shall investigate the site environment and place the laser scanner to a suitable location according to the actual requirements.



CAUTION

Safety in the area that not in the scanning range must always be considered. The system integrator shall assess the potential risks within this area and make sure that proper measures have been applied to reduce risks.

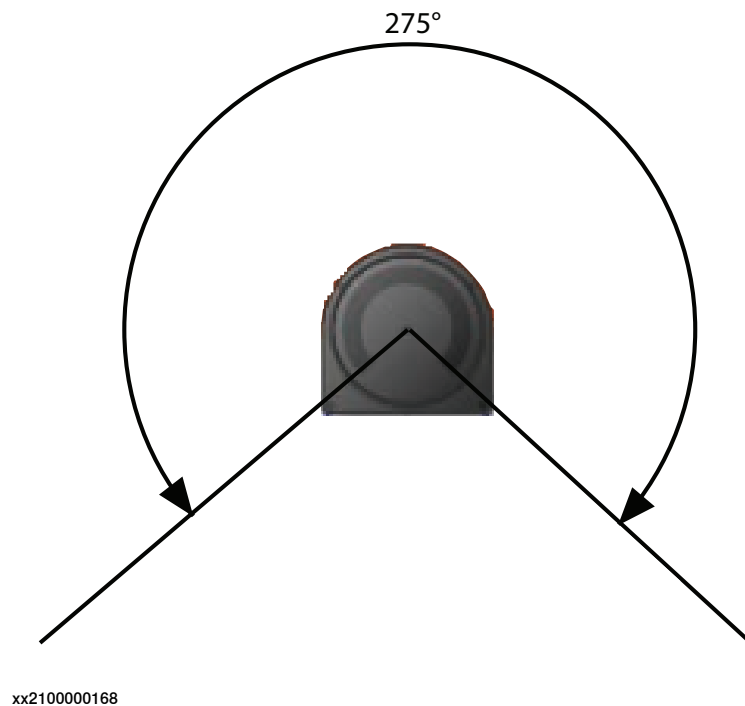

Laser scanner types

The following laser scanner package options are available:

- 1 PROFIsafe-based laser scanner (option 3051-1 PROFIsafe scanner)
- 2 PROFIsafe-based laser scanners (option 3051-3 Dual PROFIsafe scanner)
- 1 SafetyIO-based laser scanner (option 3051-2 I/O scanner)
- 2 SafetyIO-based laser scanners (option 3051-4 Dual I/O scanner)

Continues on next page

3 Installation and commissioning

3.3.10 Installation of laser scanner

Continued

Connection between PROFIsafe-based laser scanners and the OmniCore controller differs according to the PROFINET options selected and installed in the system.

- If only options [3020-2] PROFINET Device and [3023-2] PROFIsafe Device are selected and installed, the laser scanners shall connect to a PLC acting as a master first and then to the OmniCore controller with SafeMove via the PROFINET safe (PROFIsafe) network. Users need to prepare a safety PLC of their own.
- If options [3020-1] PROFINET Controller and [3023-1] PROFIsafe Controller are selected and installed, the laser scanner could communicate with the OmniCore controller directly via the WAN port.

SafetyIO-based laser scanners connects to the OmniCore controller with SafeMove and installed with the scalable I/O device DSQC1042 Safety digital base (option 3037-2). For details about the scalable I/O device, see the product specification of the controller and *Application manual - Scalable I/O*.

The supported PROFINET- and SafetyIO-base laser scanners are *SICK® microScan 3 Core* and *SICK® microScan 3 Pro*, respectively. Detailed scanner model can be obtained on the scanner nameplate. Other scanner types or models might not provide full functionality.

For more details about the safety laser scanners, see *Operating instructions microScan3 - PROFINET* and *Operating instructions microScan3 - Pro I/O* from the vendor, which are available on *SICK®* website.

Connecting the laser scanner(s)

Safety laser scanners shall be connected properly according to the scanner type and system setup.



Note

External 24V power supply shall be prepared for power connection of laser scanners.

1 PROFIsafe-based laser scanner (option 3051-1), with PLC connected

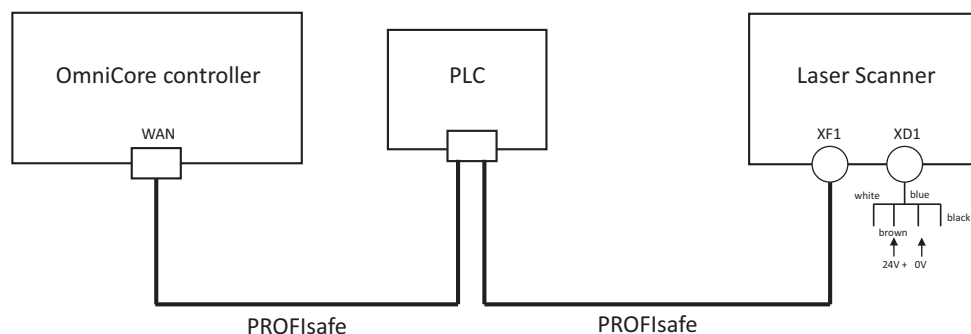

xx2100000160

Continues on next page

1 PROFIsafe-based laser scanner (option 3051-1), without PLC connected

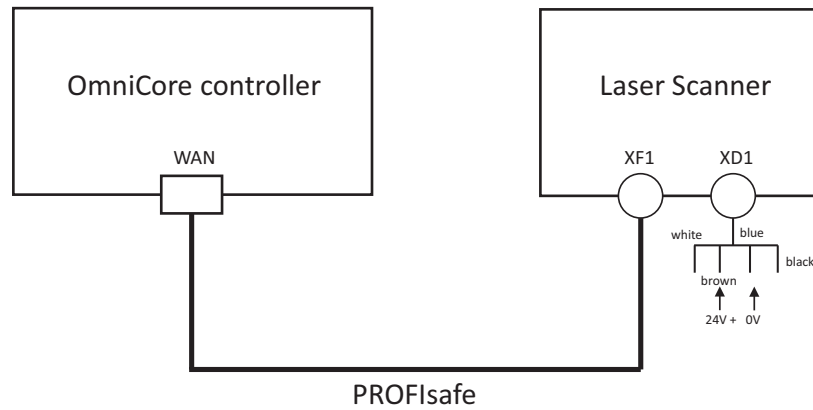

xx230000226

2 PROFIsafe-based laser scanners (option 3051-3), with PLC connected

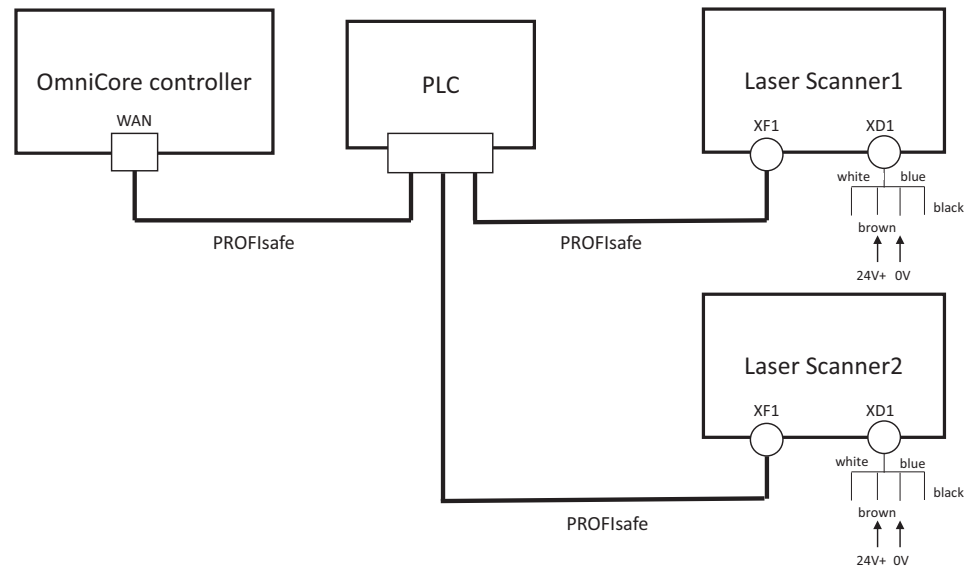

xx220000298

Continues on next page

3 Installation and commissioning

3.3.10 Installation of laser scanner

Continued

2 PROFIsafe-based laser scanners (option 3051-3), without PLC connected

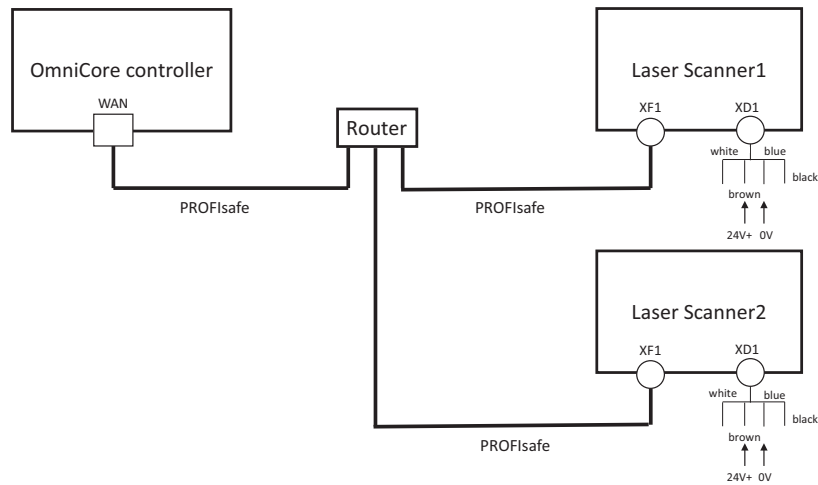

xx2300000227

1 SafetyIO-based laser scanner (option 3051-2)

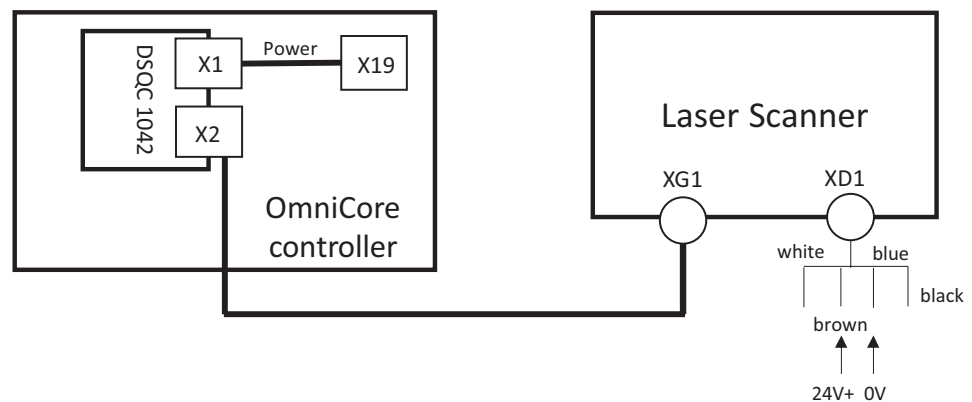

xx2200000299

Continues on next page

2 SafetyIO-based laser scanners (option 3051-4)

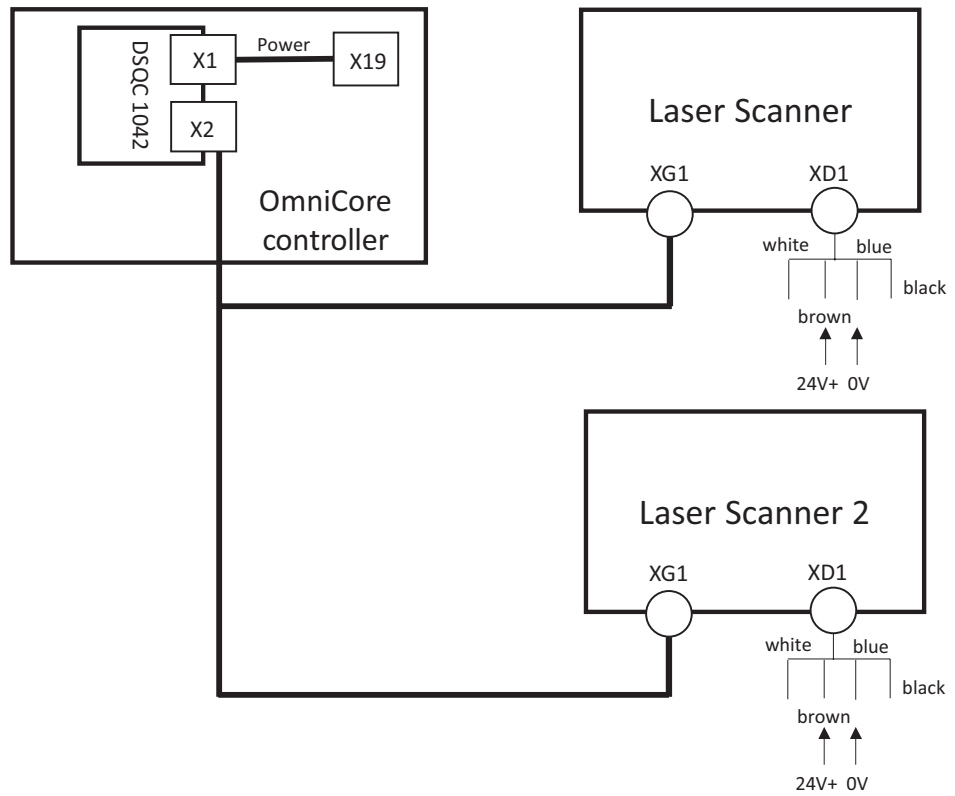

xx220000300



Note

If there are additional scalable I/O devices available, install and configure the additional devices by following the detailed procedures in *Application manual - Scalable I/O*.

Continues on next page

3 Installation and commissioning

3.3.10 Installation of laser scanner

Continued

Connector information

Pin assignment on XG1 of SafetyIO-based laser scanners

XG1 connector on SafetyIO-based laser scanner is a 17-pin, A-coded M12 female connector. Pins 1-4 and pin 17 on XG1 are occupied for connecting the laser scanner and scalable I/O device, while other 12 pins can be used for local inputs and outputs.

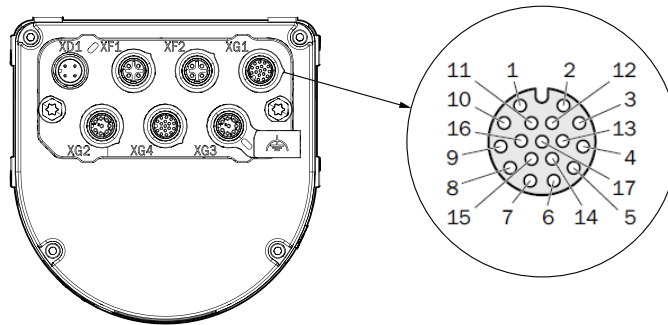

xx2300000750

Pin	Description	Wiring color
1	OSSD pair 1, OSSD A	Brown
2	OSSD pair 1, OSSD B	Blue
3	OSSD pair 2, OSSD A	White
4	OSSD pair 2, OSSD B	Green
5	Universal input 1	Pink
6	Universal input 2	Yellow
7	Universal input 3	Black
8	Universal input 4	Grey
9	Universal input 5	Red
10	Universal input 6	Violet
11	Universal input 7	Grey with pink
12	Universal input 8	Red with blue
13	Universal input 9	White with green
14	Universal input 10	Brown with green
15	Universal output 1	White with yellow
16	Universal output 2	Yellow with brown
17	Voltage 0 V DC	White with grey

Continues on next page

Configuring the laser scanner(s)

Laser scanner configuration depends on the type and number of scanners connecting to the robot and RobotWare version. Refer to the following table for applicable scenario and proceed to specific section for configuration details.

Scanner type	Works with...			Number of connected scanners	RobotWare version	Re-require... Collaborative Speed Control add-in	Refer to...
	PLC	Scalable I/O device DSQC1042	OmniCore controller with SafeMove				
PROFIsafe-based	Y	N	Y	1	RobotWare 7.5 or earlier	N	Configuration of one PROFINET-base laser scanner (RobotWare 7.5 or earlier) on page 142
	Y	N	Y	1	RobotWare 7.6 or later	Y	Configuration of one PROFIsafe-based laser scanner (RobotWare 7.6 or later and PLC acting as Master) on page 148
	Y	N	Y	2	RobotWare 7.6 or later	Y	Configuration of two PROFIsafe-based laser scanners (RobotWare 7.6 or later and PLC acting as Master) on page 152
	N	N	Y	1	RobotWare 7.10 or later	Y	Configuration of one PROFIsafe-based laser scanner (RobotWare 7.10 or later and OmniCore acting as Master) on page 156
	N	N	Y	2	RobotWare 7.10 or later	Y	Configuration of two PROFIsafe-based laser scanners (RobotWare 7.10 or later and OmniCore acting as Master) on page 160
SafetyIO-based	N	Y	Y	1	RobotWare 7.6 or later	Y	Configuration of one SafetyIO-base laser scanner (RobotWare 7.6 or later) on page 164
	N	Y	Y	2	RobotWare 7.6 or later	Y	Configuration of two SafetyIO-base laser scanners (RobotWare 7.6 or later) on page 169





Continues on next page

3 Installation and commissioning

3.3.10 Installation of laser scanner

Continued

The following table lists the required actions for specific scenarios such as RobotWare upgrade or rollback.

Scenario	Actions
RobotWare 7.5 or an earlier version upgraded to RobotWare 7.6 or a later version	<p> Note</p> <p>Applicable only when using PROFIsafe-based laser scanners</p> <ol style="list-style-type: none"> 1 Install the Collaborative Speed Control add-in. See Information about Collaborative Speed Control add-in on page 141. 2 Reconfigure the PLC and laser scanner. See Configuration of one PROFIsafe-based laser scanner (RobotWare 7.6 or later and PLC acting as Master) on page 148.
RobotWare 7.6 or a later version rolled back to RobotWare 7.5 or an earlier version	<p> Note</p> <p>Applicable only when using PROFIsafe-based laser scanners</p> <p>Reconfigure the PLC and laser scanner. See Configuration of one PROFINET-base laser scanner (RobotWare 7.5 or earlier) on page 142.</p>
Adding a new laser scanner	<ol style="list-style-type: none"> 1 Connect the new laser scanner in the same type as the one existing in the system. See Connecting the laser scanner(s) on page 92. 2 Configure the new laser scanner. See Configuration of two PROFIsafe-based laser scanners (RobotWare 7.6 or later and PLC acting as Master) on page 152 or Configuration of two SafetyIO-base laser scanners (RobotWare 7.6 or later) on page 169.
PROFIsafe-based laser scanner(s) changed to SafetyIO-based laser scanner(s)	<p> Note</p> <p>Applicable only for RobotWare 7.6 or later</p> <ol style="list-style-type: none"> 1 Reset the SafeMove configurations to factory settings by choosing Controller > Reset to factory settings in the Visual SafeMove ribbon tab in RobotStudio. 2 Update the system using Installation Manager. <ol style="list-style-type: none"> a. Unselect the installed profisafe package option(s) and select the required IO package option(s). b. Make sure option 3020-2 PROFINET Device and option 3023-2 PROFIsafe Device under PROFINET group are selected in the System Option tab page. 3 Configure the new laser scanner. See Configuration of one SafetyIO-base laser scanner (RobotWare 7.6 or later) on page 164 or Configuration of two SafetyIO-base laser scanners (RobotWare 7.6 or later) on page 169.
Connection via a PLC changed to direct connection with the OmniCore Controller	<p> Note</p> <p>Applicable only when using PROFIsafe-based laser scanners</p> <ol style="list-style-type: none"> 1 Upgrade the robot system to RobotWare 7.10 or later, and install the options [3020-1] PROFINET Controller and [3023-1] PROFIsafe Controller to the system. 2 Reconfigure the laser scanner. See Configuration of one PROFIsafe-based laser scanner (RobotWare 7.10 or later and OmniCore acting as Master) on page 156 or Configuration of two PROFIsafe-based laser scanners (RobotWare 7.10 or later and OmniCore acting as Master) on page 160.

3.4 Electrical connections

3.4.1 Robot cabling and connection points

Introduction

Connect the robot and controller to each other after securing them to the foundation. The lists below specify which cables to use for each respective application.



DANGER

Turn off the main power before connecting any cables.



CAUTION

Verify that the robot serial number is according to the number(s) in the *Declaration of Incorporation (DoI)*.

Main cable categories

The following table specifies cabling categories between the robot and the controller. Some of the cabling belong to optional applications.

Cable category	Description
Robot cables	Handles power supply to and control of the robot's motors. Specified in the table Robot cables on page 99 .
Customer cables	Handles communication with equipment fitted on the robot by the customer, low voltage signals and high voltage power supply + protective ground. The customer cables also handle databus communication. See the product manual for the controller, see document number in References on page 10 .

Robot cables

These cables are included in the standard delivery. They are completely pre-manufactured and ready to plug in.

Cable sub-category	Description	Connection point, cabinet	Connection point, robot
Robot cable (combined power and control cable + CP/CS)	Transfers DC bus power from power supply in the control cabinet to the drive units in the robot.	X2	R1.MP

Robot cable

Signal cable length	Article number
Hybrid floor cable 7 m	3HAC073212-002
Hybrid floor cable 15 m	3HAC073212-003

Continues on next page

3 Installation and commissioning

3.4.1 Robot cabling and connection points

Continued

Bending radius for static floor cables

The minimum bending radius is 10 times the cable diameter for static floor cables.

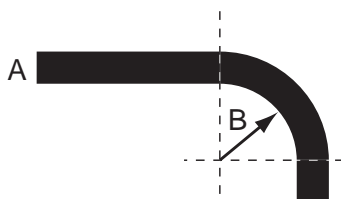

xx1600002016

A	Diameter
B	Diameter x10

3.4.2 Customer connections on the manipulator

Introduction

The customer cables are routed internally with the manipulator cable harness.

Customer cabling

Customer connection	Cable specification	Article number	Rating in each wire ⁱ	Note
Customer power (CP)	Raw cable is twisted pair 1x2xAWG24	See <i>Product manual, spare parts - CRB 15000</i>	24V ⁱⁱ 1.5A	Routed internally with the manipulator cable harness.
Customer signal (CS)	2x2xAWG26 in 4x2xAWG26 cable	See <i>Product manual, spare parts - CRB 15000</i>	24V ⁱⁱⁱ 500mA	Routed internally with the manipulator cable harness.

ⁱ Stresses above the limitation may cause permanent damage to the manipulator.

ⁱⁱ Rated 24V, max 30V

ⁱⁱⁱ Rated 24V, max 30V

Continues on next page

3 Installation and commissioning

3.4.2 Customer connections on the manipulator

Continued

Customer connectors on the manipulator

Connectors at the base

The R1.MP on the base is used for transferring DC bus, EtherCat and customer signals (CP/CS).

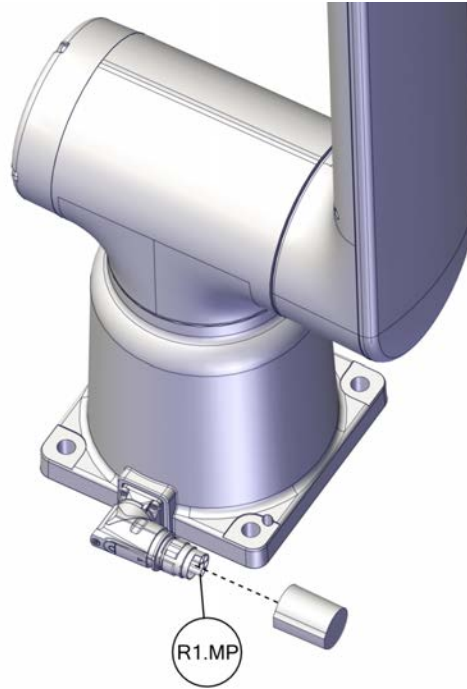

xx210000228

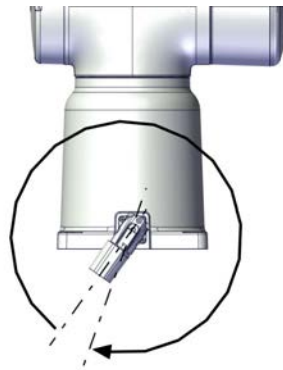

xx2100002065

-	The connector can be rotated 330° clockwise.
---	--

Continues on next page

3 Installation and commissioning

3.4.2 Customer connections on the manipulator

Continued

Pos	Connector type	Layout
R1.MP	Receptacle angled rotatable male connector with housing and insert.	<p>xx2100000221</p>
-	Plug with female connector includes housing and insert.	<p>xx2100000229</p>

Connectors at the tool flange

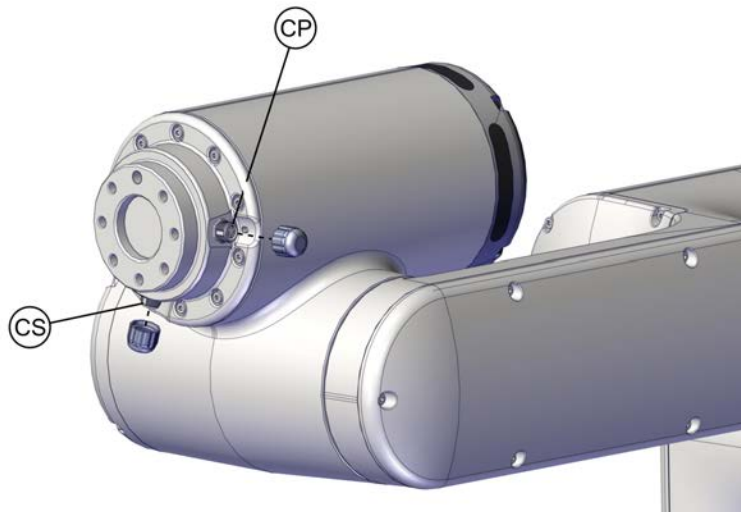

xx2100000125



CAUTION

Always use protective caps on unused customer connectors to protect the connector and to cover sharp connector edges.



Note

Always inspect the connector for dirt or damage before connecting it. Clean or replace any damaged parts.

Continues on next page

3 Installation and commissioning

3.4.2 Customer connections on the manipulator

Continued

Pos	Connector type	Torque for mating/unmating	Layout	Pin specification
CP	M8 3 pin female, 200 mm wire, straight (two pins for use, one pin is spare)	0.4 Nm	<p>xx2100000220</p>	Pins on R2.CP: 1: CP+ 3: CP- 4: NC
CS	M8 4 pin female, 200 mm wire, straight	0.4 Nm	<p>xx2100000219</p>	Pins on R2.CS: 1: CS Pair_1 + 2: CS Pair_1 - 3: CS Pair_2 + 4: CS Pair_2 -

3.5 Arm-side interface

3.5.1 Configuring the arm-side interface

Introduction

The arm-side interface is located on axis 5, opposite to the tool flange. The configuration of the arm-side interface is done using the application **ASI Setting** on the FlexPendant.

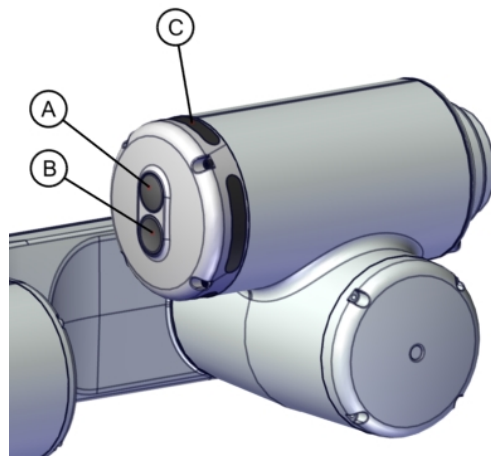

xx2000002420

A	Up button (convex button)
B	Down button (concave button)
C	Light ring

Prerequisites

A validated safety configuration must be set up before using the arm-side interface. This must be based on a risk assessment of the application. Particular attention should be paid to the risks of impact, crushing and shearing. See [The SafeMove configurator app on FlexPendant on page 120](#), and *Application manual - Functional safety and SafeMove*.

The tool and payload must be configured before configuring the arm-side interface. See *Operating manual - OmniCore*.

Continues on next page

3 Installation and commissioning

3.5.1 Configuring the arm-side interface

Continued



WARNING

When using the lead-through function from the arm-side interface, make sure that no one else can take control of the robot.

- In manual mode, by having a FlexPendant connected to the controller.
- In automatic mode, by setting up the system with caution regarding who has the user grant UAS_REMOTE_START_STOP_IN_AUTO. This grant is required to start or stop program execution in automatic mode. Any user with this grant should be located within eyesight of the robot. The FlexPendant can always be used to start or stop program execution.

See also [Working closely with the robot in a safe way on page 111](#).



CAUTION

The robot is delivered with the buttons and LED lights pre-configured. During installation this configuration must be verified before commissioning the application.



CAUTION

When using the arm-side interface, make sure to use zone limits or physical barriers to prevent contact between the manipulator and the human head. This applies both to commissioning and automatic operation.



CAUTION

During fine tuning of positions, make sure not to place your head too close to the manipulator.

Default configuration of the arm-side interface

On delivery, the up button is configured to enable lead-through. The down button is configured to add a move block in the *Wizard* software. The configuration is shown on the FlexPendant.

On delivery, the light ring shows the states according to the following table:

Color of the light ring	Description
White	Stand by state
Green	Program running
Yellow, steady	Lead through/programming mode
Yellow, blinking	Brake release signal is activated
Red	Error

Continues on next page

Configuring the buttons



Note

The buttons are deactivated until there is a valid safety configuration in the robot controller.

The buttons on the arm-side interface are configured with RAPID routines in the module `GOFA_ASI_Procedures`, located in the task `T_ROB1`.

On delivery, a number of pre-configured routines are available. These can be customized as needed, and more routines can be added. All routine names must start with `ASI_`

For the default configuration of the arm-side interface, no hazards can arise if both buttons are pressed simultaneously. Consequently, the ASI application does not trap or prevent this situation. Should the button configuration be changed, it must be checked whether hazards could arise if the buttons are pressed at the same time. If necessary, mitigations must be provided in the RAPID code. Simultaneous pressing of both ASI buttons shall be considered in the application risk assessment. To change what routine to run when pressing a button, use the FlexPendant app **ASI Setting**.

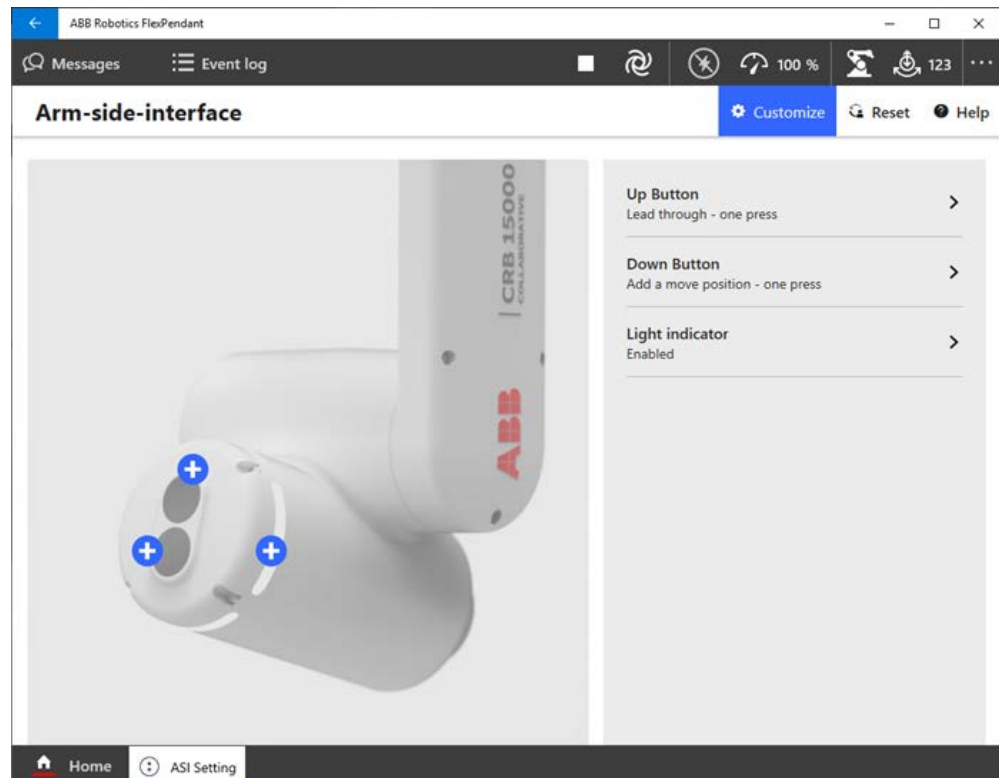

xx210000080

For more information on RAPID, see *Technical reference manual - RAPID Instructions, Functions and Data types* and *Technical reference manual - RAPID Overview*.

Continues on next page

3 Installation and commissioning

3.5.1 Configuring the arm-side interface

Continued

For more information about *Wizard*, see *Application manual - Wizard*.

Gripper

There is a routine available for the up button that can open and close a gripper. The function is toggled by each press of the button. To enable the gripper routine, open the Wizard web app.



CAUTION

Protect users from falling workpieces.

Example of RAPID routine with MoveJ

Example of customized routine with the instruction MoveJ.

```
PROC ASI_MoveRobot()  
  TPWrite "The robot will move along path";  
  MoveJ Target_10,v1000,z100,tool0\WObj:=wobj0;  
  MoveJ Target_20,v1000,z100,tool0\WObj:=wobj0;  
  MoveJ Target_30,v1000,z100,tool0\WObj:=wobj0;  
  MoveJ Target_20,v1000,z100,tool0\WObj:=wobj0;  
  MoveJ Target_30,v1000,z100,tool0\WObj:=wobj0;  
ENDPROC
```

Example of RAPID routine with TPWrite

Example of customized routine with the instruction TPWrite.

```
PROC ASI_Routine1()  
  MoveJ  
    [[0,0,0],[1,0,0,0],[0,0,0,0],[9E9,9E9,9E9,9E9,9E9,9E9]],v100,z0,tool0;  
  TPWrite "Example 1";  
ENDPROC
```

Configuring the light ring

The arm-side interface has a light ring with LED lights that indicate status. The configuration is shown on the FlexPendant.

The light will blink when a button is pressed on the arm-side interface. This can be used to verify to which robot the FlexPendant is connected, see [Testing the FlexPendant connection on page 110](#).



Note

In RobotWare 7.2, the light ring configuration cannot be changed, only disabled.

3.5.2 Using the arm-side interface



WARNING

When using the lead-through function from the arm-side interface, make sure that no one else can take control of the robot. See recommendations in [Configuring the arm-side interface on page 105](#).

Prerequisites

A validated safety configuration must be set up before using the arm-side interface. This must be based on a risk assessment of the application. Particular attention should be paid to the risks of impact, crushing and shearing. See [The SafeMove configurator app on FlexPendant on page 120](#), and *Application manual - Functional safety and SafeMove*.

The tool and payload must be configured before configuring the arm-side interface. See *Operating manual - OmniCore*.

Using the buttons on the arm-side interface

To use the function that is configured for a button, press the button. The light ring will start blinking and the defined routine will start.

If the button configured for lead-through is pressed but the arm is not moved, then the lead-through functionality is switched off after 10 seconds. For more information about lead-through, see [Lead-through on page 117](#).

The buttons on the arm-side interface can be used in both manual mode and automatic mode.



Note

The application **ASI Setting** on the FlexPendant must be open when using the buttons, if the buttons are configured differently than default.



Tip

If the buttons are not responding, close the **ASI Setting** app and reopen it.

3 Installation and commissioning

3.5.3 Testing the FlexPendant connection

3.5.3 Testing the FlexPendant connection

Introduction

The **ASI Setting** application can be used to verify to which robot the FlexPendant is connected.

- 1 In the **ASI Setting** application, select **Light indicator**.
- 2 Toggle the **Enabled** switch to turn on or off the light ring on the robot.
- 3 Inspect on which robot the light ring is affected.



Note

This technique should also be used to verify a Robot Control Mate connection before starting work.

3.5.4 Working closely with the robot in a safe way

Risk reduction when using the arm-side interface

A risk assessment must always be conducted when commissioning a robot or robot application (see ISO 10218-2). Important steps in this process are:

- Determine the limits of the machine
- Identify hazards
- Estimate and evaluate risks
- Perform an adequate risk reduction.

When someone uses the arm-side interface (ASI), they must be standing close to the manipulator. The risk assessment must therefore identify and address the possibility of collisions with the operator. These can be either unconstrained or constrained collisions, as explained below. Potential hazards to be addressed are crushing, cutting, shearing and impact, amongst others.

The arm-side interface can be used in both manual and automatic modes.

- In manual reduced speed mode, risk reduction as required by ISO 10218-1 is used:
 - 250 mm/s speed limit
 - A three-position enabling device to permit motion
- In Automatic mode, the system integrator must perform an application-specific risk assessment and risk reduction, resulting in a validated safety configuration. Use of the arm-side interface requires such a safety configuration.

Safety zones to implement speed and force limits can help to reduce the risks to an acceptable level. Further information is provided below. Programming information is provided in the RAPID manual for programming (*Technical reference manual - RAPID Instructions, Functions and Data types*), while the configuration and validation of a safety configuration is addressed in *Application manual - Functional safety and SafeMove*. In some cases, constructional measures may also be necessary to ensure that the application complies with ISO/TS 15066, which provides the relevant biomechanical limits.

Unconstrained collisions

An unconstrained collision is one where the body part involved is not trapped. Under these circumstances, only transient collisions are possible.

The risks from unconstrained collisions can be reduced by creating a zone to implement Cartesian speed limits, set by the safety function *Tool Speed Supervision* (see *Application manual - Functional safety and SafeMove*). Assistance with setting the limits is provided by the supporting function *Human Interaction Supervision*. Guidance and biomechanical limits are provided in ISO/TS 15066.

Constrained collisions

A constrained collision is one where the body part involved is trapped between the robot and another fixed object, or two parts of the robot. Constrained collisions can be either transient, if the robot can give way (at least partially), or quasi-static.

Continues on next page

3 Installation and commissioning

3.5.4 Working closely with the robot in a safe way

Continued

Wherever possible, constrained collisions shall be prevented by safely restricting the robot motion. This can be done by using the safety functions *Tool Position Supervision* and *Axis Position Supervision* (see *Application manual - Functional safety and SafeMove*). The programmed limits must allow for stopping distances.

Where there is a risk of constrained collisions (for example, due the purpose of the application), a zone shall be constructed where the safety function *Tool Force Supervision* is used to limit the contact forces. Assistance with parameter settings is provided by the supporting function *Human Interaction Supervision*. The limits are provided in ISO/TS 15066. Low speed limits are required to make the force limits effective, otherwise the system cannot react fast enough.

SafeMove can only supervise motion compared to the position and speed limits set within a zone. The manipulator may therefore leave a zone at the maximum safe speed allowed within that zone. This is important for the transition between unconstrained and constrained collision zones.

To achieve safe constrained collisions, either:

- 1 The constrained collision zone must be deep enough that the manipulator stops before hurting the operator. This must happen even if it enters the zone at the maximum speed allowed in the neighboring zone.

Or:

- 2 The speed must be reduced in the neighboring safety zone, to ensure that the manipulator stops in time.

These approaches can be combined. Additional safety zones can also be introduced between the constrained and unconstrained collision zones to improve the cycle time.

Deviation: Single Point of Control

There is a deviation to ISO 10218-1 §5.3.5 in that the robot does not guarantee a Single Point of Control in automatic mode. This means that any clients connected to the robot and used for starting and stopping program execution must be considered when allowing the operator to use the ASI. Such clients include FlexPendant, RobotStudio, Robot Control Mate, or other Robot Web Services applications. It also includes external PLCs starting the robot via System Inputs.

The integrator must ensure that these additional clients cannot lead to an unacceptable risk to the user in automatic mode. There are several solutions to reduce the risk in automatic mode:

- 1 For any operation of the arm-side interface in automatic mode, a validated safety configuration must be in place to prevent collisions between manipulator and user, or to ensure that they are safe. As described above, this can be achieved by a combination of safety functions and constructional measures. Appropriate safety functions must be activated for the complete range of motion of the application.
- 2 To prevent unexpected motion, initiated by additional clients:

Do not add additional clients to the robot to control program execution.

Continues on next page

If additional clients are needed, ensure that their interaction with the controller can be disabled. Disable them while using the arm-side interface.

Introduce organizational measures to prevent start of the programmed motion while someone is using the arm-side interface. For example: it shall be possible to visually confirm that the area around the robot is clear.

Finally, if risks in automatic mode cannot be sufficiently reduced by these or other means, use of the arm-side interface shall be restricted to manual mode.

3 Installation and commissioning

3.6.1 Information about software for the CRB 15000

3.6 Configuring the software

3.6.1 Information about software for the CRB 15000

Overview

CRB 15000 is designed to simplify collaborative applications. Therefore some software features work somewhat different compared with standard industrial robots. Some of them are listed in this section.

How to configure RobotWare is described in *Operating manual - Integrator's guide OmniCore*.

Emergency stops

The configuration of emergency stops is stop category 1 and cannot be changed.

Collision detection

As default CRB 15000 will have collision detection active at stand still. It also has another stop ramp compared to other robots to be able to release clamping forces.



Note

If the tool data is wrong, false collisions might be triggered and the robot arm might drop a short distance during the stop ramp.

Recommendations for configuration of single point of control

Single point of control is the ability to operate the robot such that initiation of robot motion is only possible from one source of control and cannot be overridden from another initiation source.

In manual mode, the FlexPendant always has highest priority and can be used to start and stop program execution, jog, and configure the system. Other clients can connect to the robot, for example RobotStudio.

In automatic mode, there is no difference in priority between clients connected to the robot. The FlexPendant can always be used to start or stop program execution. Any remote client must have the user grant UAS_REMOTE_START_STOP_IN_AUTO to be able to start or stop program execution in automatic mode. Any user with this grant should be located within eyesight of the robot, unless there are presence sensing devices installed that can prevent potentially hazardous situations.

Local presence and local client

As a rule of thumb, having local presence near the robot is recommended when changing operating mode, starting or stopping execution, or jogging. This is to ensure that no one else is near the robot before doing anything that can cause a potentially hazardous situation.

A local client is a client connected directly to the robot controller, not over the network. The FlexPendant is always local client.

To become logged in as local client you must have local presence. By design, only one client can be local at any given time.

Continues on next page

With the FlexPendant, a user can verify local presence with the three-position enabling device. For robots without a connected FlexPendant, system input signals can be used to verify local presence.



CAUTION

It is the responsibility of the integrator to implement that local presence is set up in a correct way.

It is the responsibility of the integrator to implement that single point of control is set up in a correct way.

SafeMove

The functional safety and SafeMove configuration can be done in RobotStudio or on the FlexPendant. The functionality in RobotStudio is more extensive. Both interfaces are described in detail in *Application manual - Functional safety and SafeMove*. The FlexPendant user interface is also described in this manual, see [The SafeMove configurator app on FlexPendant on page 120](#).

Singularities

Some positions in the robot working space can be attained using an infinite number of robot configurations to position and orient the tool. These positions, known as singular points (singularities), constitute a problem when calculating the robot arm angles based on the position and orientation of the tool.

Generally speaking, a robot has two types of singularities; arm singularities or wrist singularities.

The wrist singularities for the GoFa robot are different from other robots, due to the design.



Note

The singularities can, in combination with large tools, require thorough validation of forces if there is a risk of clamping situations.

3 Installation and commissioning

3.6.1 Information about software for the CRB 15000

Continued

Some typical examples of singularity positions for GoFa are shown here.

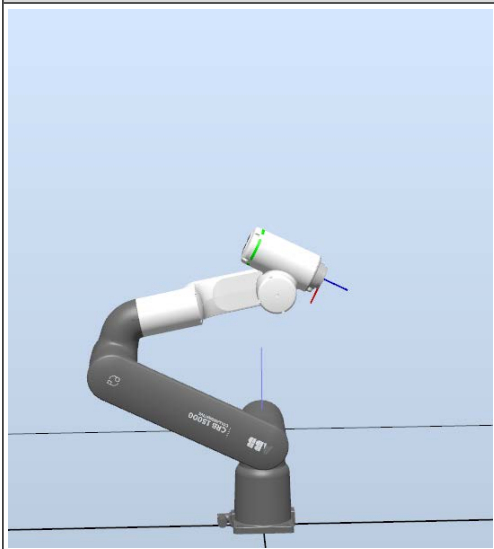
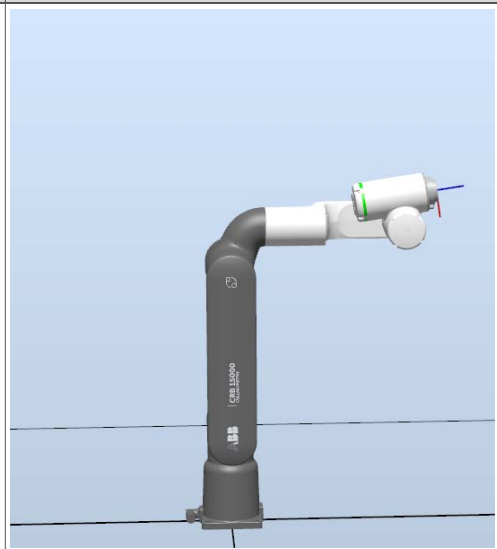
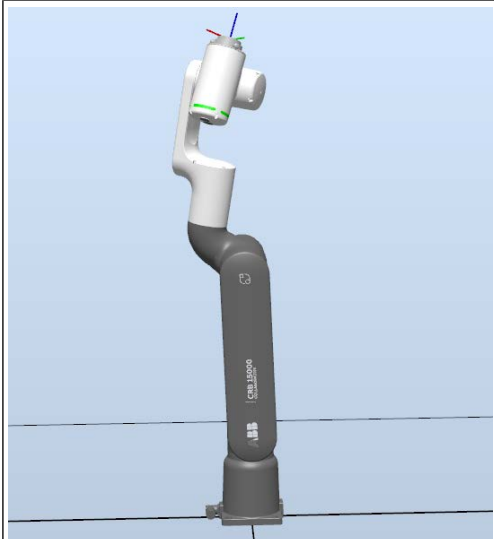
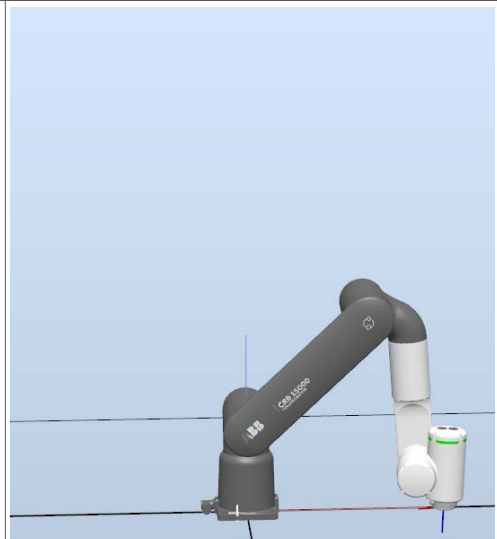
Typical arm singularities	Typical wrist singularities
 <p data-bbox="416 898 531 920">xx2300000098</p>	 <p data-bbox="911 898 1026 920">xx2300000099</p>
 <p data-bbox="416 1487 531 1509">xx2300000101</p>	 <p data-bbox="911 1487 1026 1509">xx2300000100</p>

For more information about singularity, see *Technical reference manual - RAPID Overview*, section *Singularities*.

3.6.2 Lead-through

What is lead-through?

The lead-through functionality is available for robots designed for collaborative applications. If lead-through is available, this is shown on the FlexPendant.

Using lead-through, you can grab the robot arm and move it manually to a desired position, as an alternative to jogging.

Using lead-through

Use the following procedure to jog the robot using the lead-through functionality:

- 1 Enable lead-through in one of the following ways:
 - Press the thumb button on the FlexPendant.

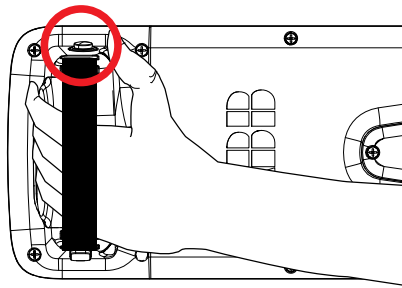

xx210000331

- On the start screen, tap **Jog** and select the **Lead-through** menu.
- In the **QuickSet** menu, select the **Lead-through** tab.



Note

If the robot is in motors off state, it will automatically go to the motors on state when the lead-through is enabled.

- 2 In the **Jog Mode** section select a mode.
- 3 If required, in the **Lead-through lock** section use the lock button next to a axis to lock it.



Note

The **Lead-through lock** section is disabled for the **Axis 1-6** mode.

- 4 Gently pull the robot arm to the desired position.

Continues on next page

3 Installation and commissioning

3.6.2 Lead-through

Continued

The robot moves to the selected position. If the **Lead-through lock** option is selected, the robot moves in such a way that the movement is restricted in the locked direction.



Note

You can feel if an axis reaches its end position. Do not try to force the axis beyond this position.

- 5 If desired, save the position.



Note

The speed at which the robot moves when using the Lead-through functionality is managed using the horizontal scroll bar available in the **Lead-through Speed** section.

Lead-through can also be enabled using the RAPID instruction `SetLeadThrough`, or a button on the arm side interface, see [Arm-side interface on page 105](#). If the lead-through button is pressed but the arm is not moved, then the lead-through functionality is switched off after 10 seconds.

Lead-through is possible in both manual and automatic mode.



Note

If lead-through is enabled, it will be temporarily disabled during program execution and jogging. This means that it is possible to combine lead-through, jogging, and testing the RAPID program without having to disable the lead-through.



Note

When using lead-through, it is important that the load is correctly defined. If the load is heavier than defined, the effect will be the same as if you are pulling the robot arm downwards. If the load is lighter than the defined load, the effect will be the same as if you are pulling the robot arm upwards.

For the CRB 15000, there is a button for updating/refreshing the load while lead-through is active.

For the CRB 15000, if varying loads from cables and other disturbances are causing the robot to drift during lead-through, this can often be improved by setting the system parameter *Lead through load compensation* to *Always*. See *Technical reference manual - System parameters*, section *Motion*, type *Robot*.

Align to a coordinate system

It is possible to align the robot to a coordinate system either in Auto or Manual mode from the lead-through page for a CRB 15000 robot.

Use the following procedure to align the robot to a coordinate system:

- 1 In the Lead-through page select the a mode in the **Lead-through Mode** section.

Continues on next page

- 2 In the **Align to coordinate system** section, select the required coordinate system.
- 3 Enable the motors.



Note

For collaborative robots, the motors are on by default unless extra safety options are selected in the system.

- 4 Tap and hold the **Press and Hold Align** button.
The robot is aligned to the selected coordinate system.

3 Installation and commissioning

3.6.3 The SafeMove configurator app on FlexPendant

3.6.3 The SafeMove configurator app on FlexPendant

Introduction

The application **SafeMove** on the FlexPendant offers an intuitive way to visualize and configure a safety configuration for systems with the option *SafeMove Collaborative*. This includes stop functions and *Cyclic Brake Check*. To get started, see [Use cases on page 123](#).



Tip

Use the online user guide tool, included in the SafeMove configurator app, for help with the SafeMove configuration setup process.



Note

The SafeMove configurator app is available for the following robots:

- CRB 1100
- CRB 1300
- CRB 15000

The configuration follows the same principles as when using Visual SafeMove in RobotStudio but the functionality is not as extensive.

For more information about transient contact, quasi-static contact, and body areas, see [Guidelines for transient and quasi-static contact, CRB 15000 on page 132](#).

Overview of the user interface

The user interface consists of a configurator and a 3D model that visualizes the robot with the configured encapsulations and zones. The first time that the app is opened, a default factory setting is loaded. If a safety configuration is loaded, this will be shown.

- The tab **Robot Encapsulation** contains the configuration of the encapsulations of the robot itself.
- The tab **Tool Encapsulation** contains the configuration of the encapsulations of the tools.
- The tab **Tool Data** contains the configuration for the tools.
- The tab **Safe Zones** contains the configuration of the safe zones.
- The tab **Global Settings** contains the configuration for Cyclic Brake Check and supervision settings.
- The tab **Synchronization** contains functions for software synchronization.
- The **Context menu (...)** contains functionality for loading, saving, and viewing configurations, and to reset the configuration.

The functionality is described in detail in *Application manual - Functional safety and SafeMove*.

Continues on next page

Prerequisites

- The option *SafeMove Collaborative* is required.
- To edit a configuration, the grant *Safety Services* is required. A user without this grant can view a configuration, but not modify, write it to the controller, or apply it to the controller.

Template configurations

The template configuration is adapted for the specific manipulator, and typically contains one or two encapsulations of the arm, one encapsulation of the wrist (intended for the tool), one or two safe zones, and a Cyclic Brake Check setting. This configuration is typically a good start for a generic application with a smaller tool.

The factory setting is an empty safety configuration. A loaded configuration can be removed and the system is then reset to the factory setting.

Encapsulations

The encapsulations are geometries that can be in the shape of a sphere, capsule, or lozenge. A sphere or capsule encapsulation can be modified in dimension and position. A lozenge capsule can be modified in dimension, position, and rotation.

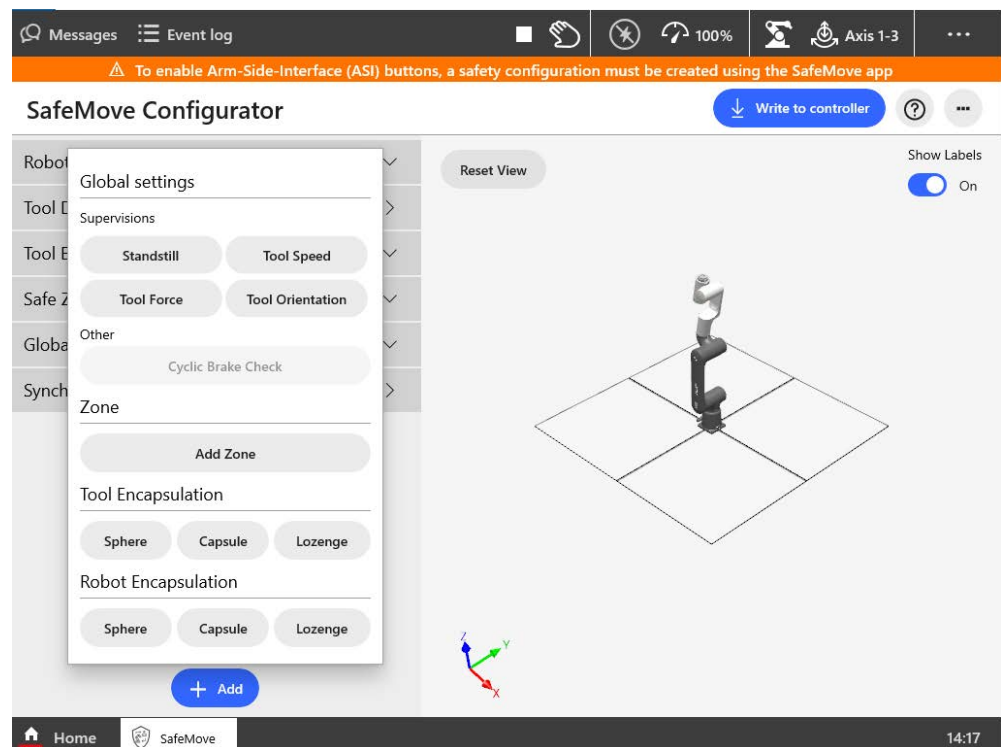

xx2100000712

Continues on next page

3 Installation and commissioning

3.6.3 The SafeMove configurator app on FlexPendant

Continued

Safe zones

The default safe zone is a rectangular box with four vertices. The vertices defines the shape of the safe zone, and the position in space. More vertices can be added to define the safe zone. The minimum number of vertices is 4, and the maximum is 24.

Each vertex can be edited in x and y values.

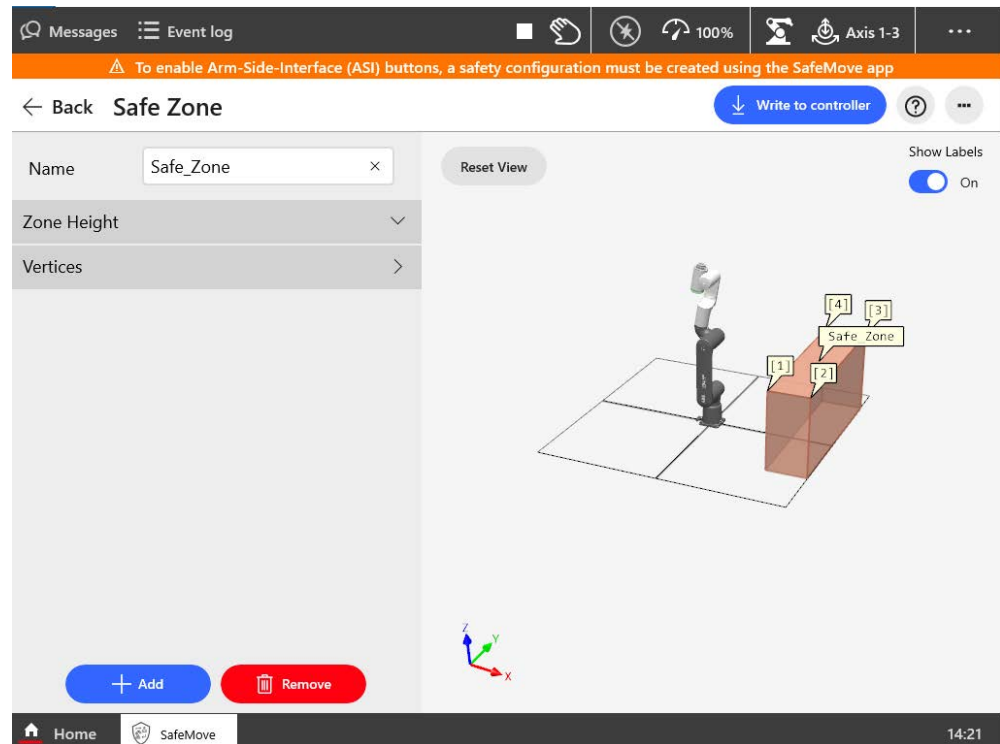

xx210000714

Each vertex is numbered, from 1 and up. When a new vertex is added between two existing vertices the vertex numbers will be automatically adjusted so that they come in order. For example, if a new vertex is added between vertices 2 and 3, the vertex with index 3 will change to 4 and the new vertex will be indexed 3.

Supervision functions

The global supervision functions are not connected to a specific safe zone or safe range. They can be added, modified, and deactivated.

For more information about the global supervision functions, see *Application manual - Functional safety and SafeMove*.

Synchronization

The **Synchronization** tab is used to manually set the current joint positions for the robot.

For more information about synchronization, see *Application manual - Functional safety and SafeMove*.

Continues on next page

Recommended working procedure

Use this procedure when configuring SafeMove in the configurator app on FlexPendant.

- 1 Log in as a user with safety user grants.
- 2 Start the SafeMove configurator app.
- 3 Load a template configuration or an existing configuration from the **Context** menu (...).
- 4 Configure encapsulations.
- 5 Configure zones and the supervision functions.
- 6 Load the configuration to the safety controller.
The robot controller is automatically restarted in this step.
- 7 Validate the configuration.
- 8 Set the safety configuration to validated and lock it.

For more details, see [Use cases on page 123](#).

For functionality not supported in the SafeMove configurator app, use Visual SafeMove in RobotStudio.

Use cases

Starting the SafeMove configurator app

The SafeMove configurator app is available on the home screen of the FlexPendant for systems with the option *SafeMove Collaborative*. If the app is not shown, then review the system settings in RobotStudio Installation Manager and add the option.

The first time that the app is opened, a default factory setting is loaded. This contains only the manipulator with *Cyclic Brake Check* activated. There are no encapsulations, safe zones, or tool data defined.

The factory setting can always be resumed, if needed.

To continue and create a safety configuration, see [Use the template configuration on page 123](#).

Use the template configuration

Use the following procedure to load and apply the template configuration to the robot controller.

- 1 Select **Enable Edit Mode** to edit the safety configuration.

Continues on next page

3 Installation and commissioning

3.6.3 The SafeMove configurator app on FlexPendant

Continued

2 Select Template configuration.

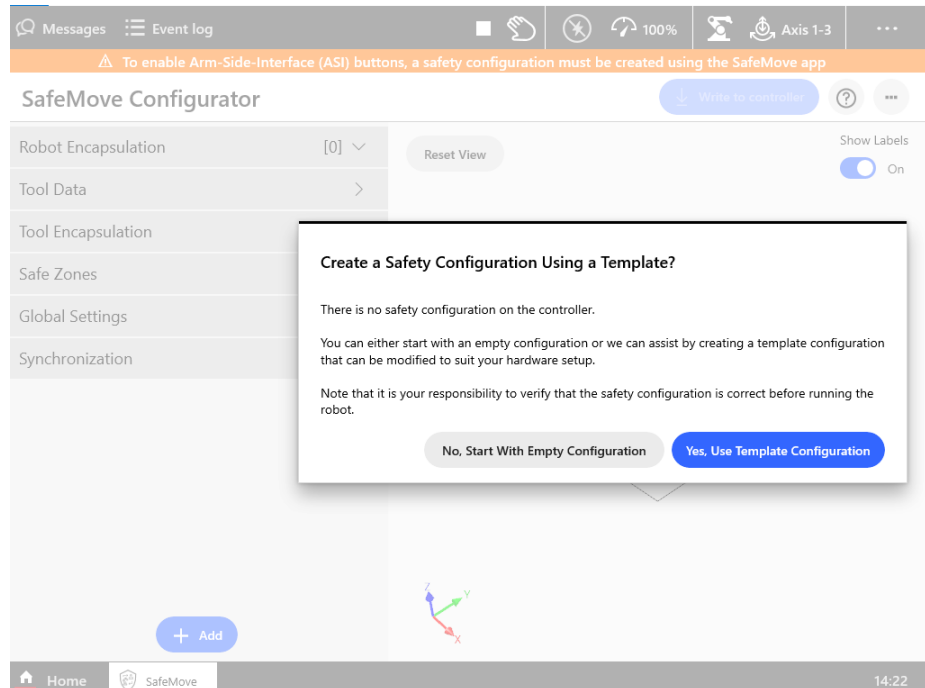

xx2100000715

- 3 Review that the template configuration is suitable for the intended application. If modifications are needed, see [Modify a configuration on page 124](#).



Note

A SafeMove configuration must always be validated to verify that the desired safety is achieved. If no validation is performed, or the validation is inadequate, the configuration cannot be relied on for personal safety.

- 4 If the template configuration is suitable, select **Write to controller**. The safety report is presented on the screen.
- 5 Save the safety report. Print out and sign this safety report. See [ABB Safety Configuration Report on page 130](#). More information about the safety report and how to validate is described in *Application manual - Functional safety and SafeMove*.
- 6 Select **Apply to controller** to proceed. The controller is automatically restarted when applying the configuration.

Modify a configuration

Use the following procedure to modify a loaded configuration and apply it to the robot controller.

- 1 Select **Enable Edit Mode** to edit the safety configuration.
- 2 If no configuration is loaded, load an empty configuration or a template configuration.

Continues on next page

- 3 To add or modify an encapsulation, tap **Add** and select a geometry for **Robot Encapsulation** or **Tool Encapsulation**.

To modify the encapsulation, select it and modify the attributes.

- 4 To add or modify a zone, tap **Add** and **Add Zone**.

Select the safe zone and modify the attributes. See [Modify a safe zone on page 125](#).

- 5 To add or modify a global setting, tap **Add** and select which supervision to modify.

- 6 When the configuration is done, select **Write to controller**.

The safety report is presented on the screen.



Note

A SafeMove configuration must always be validated to verify that the desired safety is achieved. If no validation is performed, or the validation is inadequate, the configuration cannot be relied on for personal safety.

- 7 Save the safety report. Print out and sign this safety report.

The safety report and how to validate is described in detail in *Application manual - Functional safety and SafeMove*.

- 8 Apply the configuration to the controller.

The controller is automatically restarted when applying the configuration.

Modify a safe zone

Use the following procedure to modify a safe zone.

- 1 Add a new safe zone or select an existing safe zone.

- 2 Tap **Safe Zones** to open the attributes.

- 3 Add, modify, or remove vertices as needed to create the desired shape of the safe zone.

The green dot in the 3D visualization shows where the new vertex is located. Use the arrows to change the position (index).

3 Installation and commissioning

3.6.3 The SafeMove configurator app on FlexPendant

Continued

Tap the grey Add button to place the vertex.

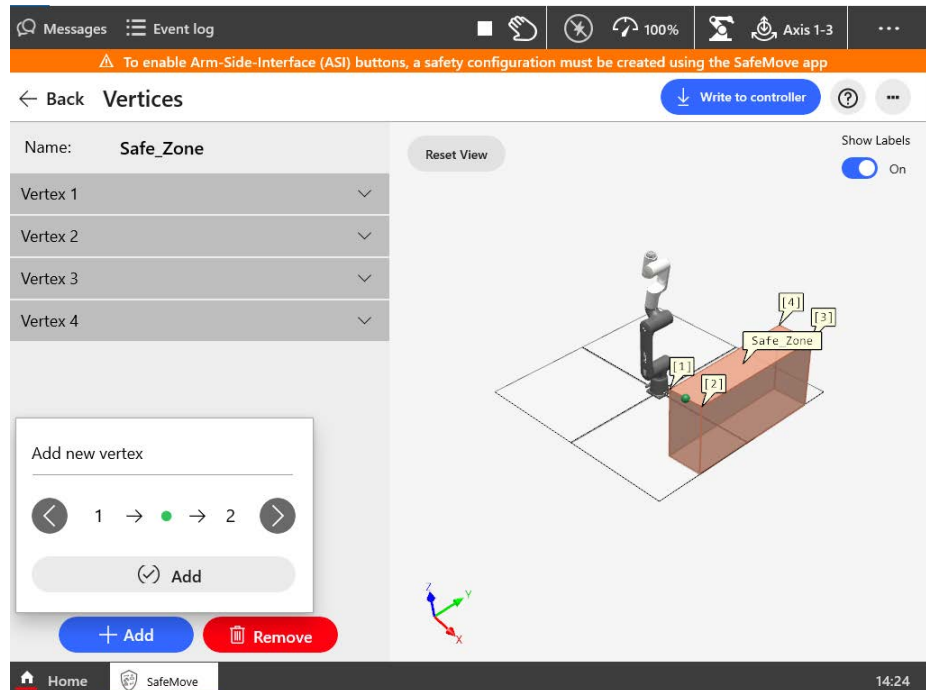

xx210000710

- 4 To add a supervision to a safe zone, tap to select the safe zone in the 3D view, then tap Add.
- 5 Select a supervision function or guide.

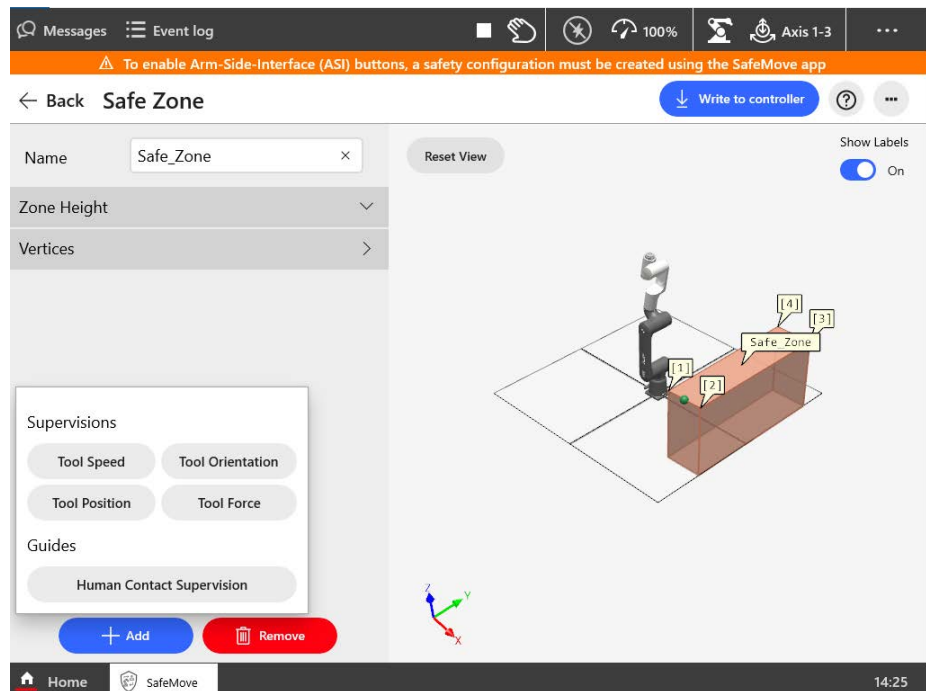

xx210000713

Continues on next page

- 6 For supervision functions, select stop category, signal, and any other available setting applicable for the function.
- 7 For the guide **Human Contact Supervision**, select contact type, tooling properties, and body contact areas.

See [Use the Human Contact Supervision settings on page 127](#).



Tip

The functionality is described in detail in *Application manual - Functional safety and SafeMove*.

Use the Human Contact Supervision settings

Use the following procedure for Human Contact Supervision.

- 1 Select **Human Contact Supervision**.
- 2 Select contact type.
- 3 Define the tooling properties.
- 4 Select body contact areas. This is only used for transient contact.
- 5 Review the suggested supervisions.
- 6 When the supervision is applied, the data is transferred to *Tool Speed Supervision* and *Tool Force Supervision*.

For more details, see [Guidelines for transient and quasi-static contact, CRB 15000 on page 132](#).

3 Installation and commissioning

3.6.3 The SafeMove configurator app on FlexPendant

Continued

Modify the Standstill Supervision settings

The Standstill Supervision functionality is not active by default. It can be added, modified, and deactivated.

The CRB 15000 has support for both stop category 0 and stop category 1 for Standstill Supervision. For other stops, only stop category 1 is available.

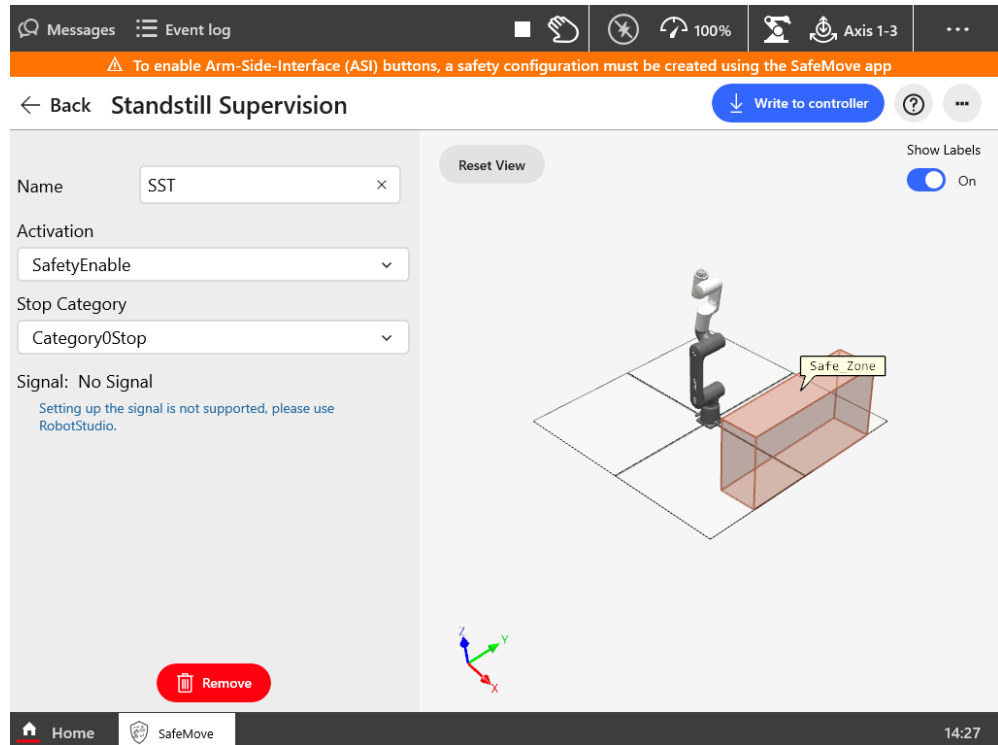

xx2100000251

Modify the global supervision settings

The global supervision functions are not connected to a specific safe zone or safe range. They can be added, modified, and deactivated.

Continues on next page

Modify the Cyclic Brake Check settings

The Cyclic Brake Check functionality is active by default. It can be modified and deactivated.

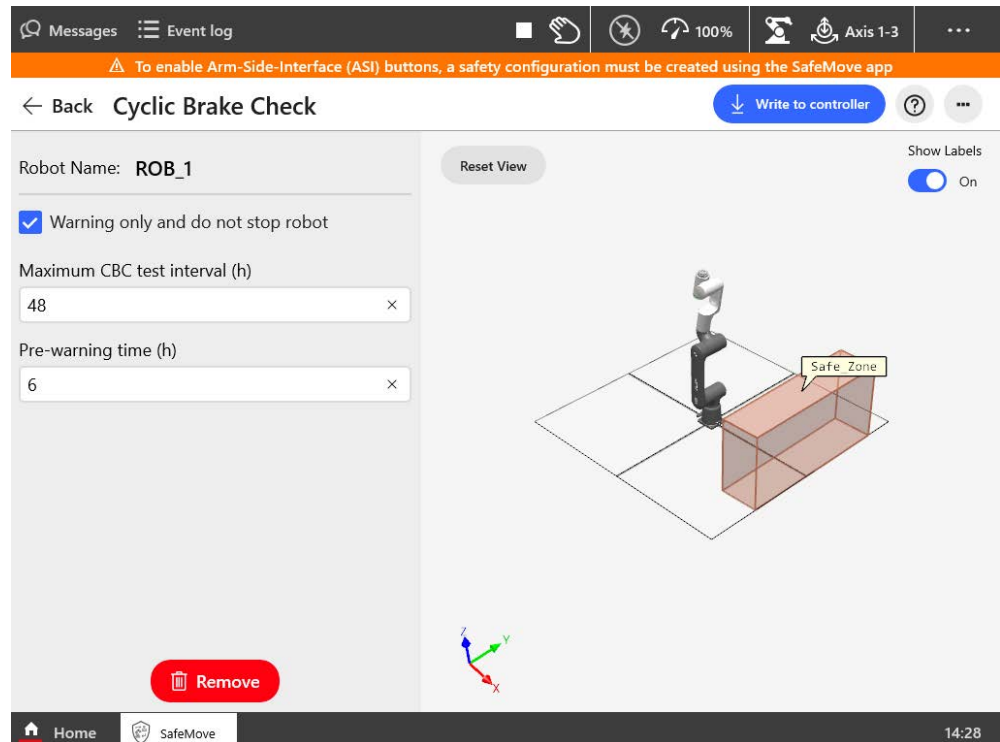

xx2100000717

Viewing the configuration report

The configuration report is available both on the FlexPendant and on the controller. It can be viewed from the **Context** menu.

Loading and exporting a safety configuration

An existing safety configuration on the FlexPendant can be exported from the **Context** menu, **Save Configuration To File**. It is also possible to load a safety configuration from a file.

Validate the safety configuration



DANGER

A SafeMove configuration must always be validated to verify that the desired safety is achieved. If no validation is performed, or the validation is inadequate, the configuration cannot be relied on for personal safety.

Each new or modified safety configuration must be validated before running in production. The validation should verify that the following is configured correctly:

- All I/O settings and signals used for safety interlocking including connected functionality
- All Stop configuration functions

Continues on next page

3 Installation and commissioning

3.6.3 The SafeMove configurator app on FlexPendant

Continued

- All safety zones with connected supervision functions and signals used for safety interlocking
- All global supervision functions
- All tools with corresponding supervision functions



Note

Depending on the combination of functions, the validation procedures have to be modified for the specific configuration.

A more detailed description of validation of the safety configuration is found in *Application manual - Functional safety and SafeMove*.

After safety configuration is validated, it must be set to validated and locked in the system.

Preparations before validation

Do the following checks before you start the validation procedure:

- 1 Carry out the synchronization procedure.
- 2 If configured, run the service routine for the function Cyclic Break Check.
- 3 Turn off the *SafeMove Assistant* functionality, with the system parameter *Disable SafeMove Assistant*.
- 4 Turn off collision detection during validation of any tool force supervision
- 5 Start the validation procedure.

If using protected groups in the safety configuration, only the modified parts must be validated.

ABB Safety Configuration Report

The validation of each function should be documented in the safety report by signature of the validator.

The safety configuration report lists all parameters that are set for the installation. The report also includes a visual representation of the installation, a floor plan. This shows the robot and safety zones as seen from above.

The configuration report includes the checksum (multiple checksums if using protected groups in the safety configuration). The checksum can also be read using the RAPID function `SafetyControllerGetChecksum` or `SafetyControllerGetGroupChecksum`.

Setting the configuration to validated

When the safety technician has validated the configuration and signed the safety report, the status of the configuration shall be changed to **Validated** on the FlexPendant.

- 1 Log in as a user with the grant **Safety Services**.
- 2 In the **Settings** app, select the **Safety Controller**, and then **Configuration**.
- 3 Select the check box **Validated**.

Continues on next page

Setting the configuration to locked

When the responsible safety user has approved the validation of the configuration, the status of the configuration should be changed to **Locked** on the FlexPendant.

Running the robot in auto mode with the configuration unlocked will result in a warning message.

- 1 Log in as a user with the grant **Lock Safety Controller Configuration**.
 - 2 In the **Settings** app, select the **Safety Controller**, and then **Configuration**.
 - 3 Select the check box **Locked**.
-

Concluding steps

After the validation is concluded, turn on the the *SafeMove Assistant* functionality, with the system parameter *Disable SafeMove Assistant*.

3 Installation and commissioning

3.6.4 Guidelines for transient and quasi-static contact, CRB 15000

3.6.4 Guidelines for transient and quasi-static contact, CRB 15000

About Human Contact Supervision

The CRB 15000 robot is designed with collaborative applications in focus, where occasional contact between the human and the robot are foreseen. This is according to ISO/TS 15066.

The supporting function *Human Contact Supervision* in SafeMove can be used to calculate maximum allowed tool force and tool speed.

Transient contact and quasi-static contact

Transient contact is contact between an operator and part of a robot system, where the operator body part is not clamped and can recoil or retract from the moving part of the robot system.

Quasi-static contact is contact between an operator and part of a robot system, where the operator body part can be clamped between a moving part of a robot system and another fixed or moving part of the robot cell.

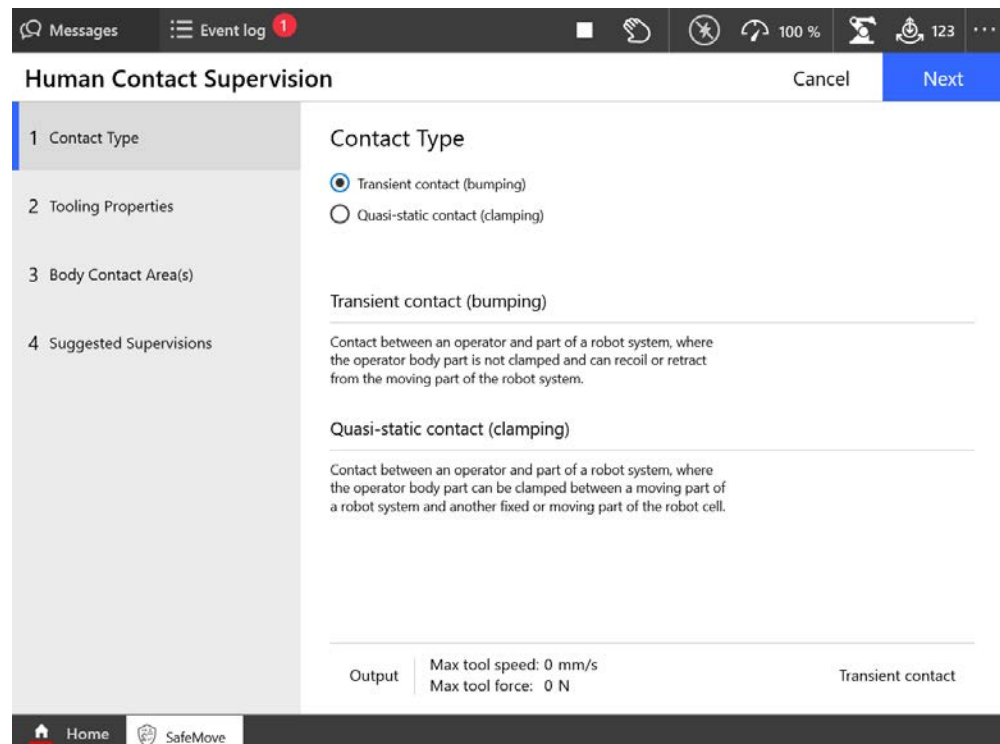

xx210000711

Continues on next page

Body model

As defined in ISO/TS 15066, the body model is a representation of the human body consisting of individual body segments characterized by biomechanical properties.

The segments of the body model has different sensitivity. In general, the application should be designed so that the human head and neck is never exposed to hazards.

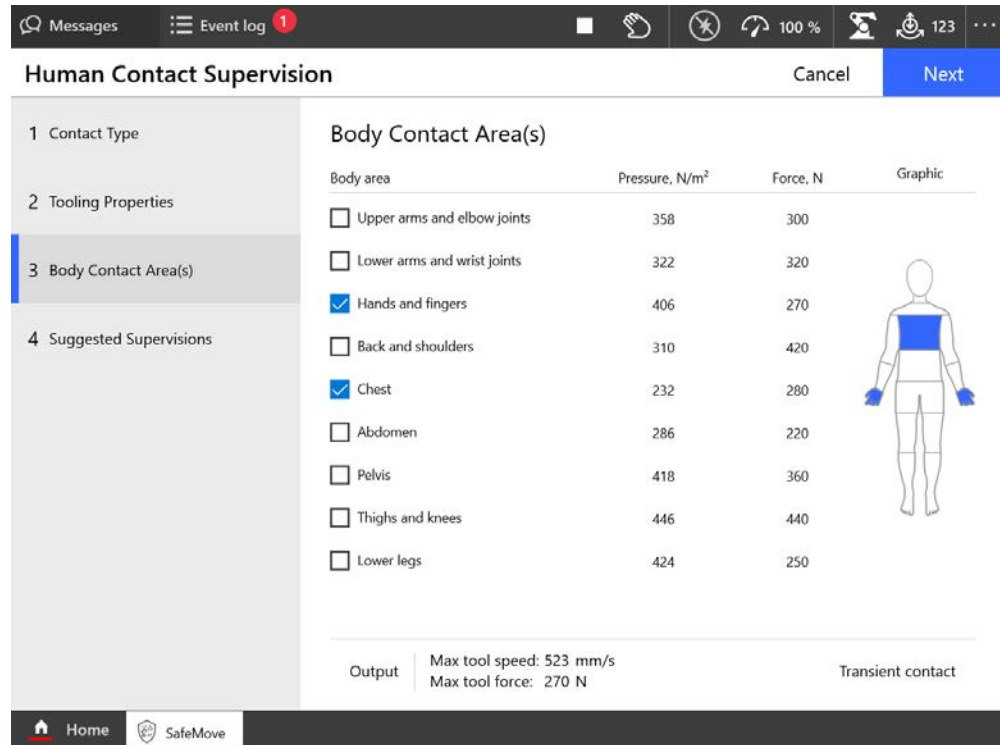

xx210000709

Recommendations from ISO/TS 15066

A key process in the design of the collaborative robot system and the associated cell layout is the elimination of hazards and reduction of risks, and can include or influence the design of the working environment. The following factors shall be taken into consideration:

- 1 The established limits (three dimensional) of the collaborative workspace.
- 2 Collaborative workspace, access, and clearance.
- 3 Ergonomics and human interface with equipment.
- 4 Use limits.
- 5 Transitions.

For more information, see ISO/TS 15066.

Continues on next page

3 Installation and commissioning

3.6.4 Guidelines for transient and quasi-static contact, CRB 15000

Continued

Conclusion

The values calculated in the **Human Contact Supervision** function are conservative. However, if the risk assessment for the final application shows that these values can be changed to a higher value, for example, by using padding on the arm, then the values can be changed in the settings for the tool force supervision and tool speed supervision.



CAUTION

The functionality is based on the recommendations in ISO/TS 15066. A risk assessment of the final application must always be done, where the calculations are reviewed and verified by test.

3.6.5 Configuration of SafeMove using Visual SafeMove in RobotStudio

General

This section describes SafeMove configuration using Visual SafeMove for scenarios with PROFIsafe-based laser scanners connected and OmniCore controller acting as master.

What is Visual SafeMove

Visual SafeMove is the configuration tool for SafeMove and the functional safety options. The tool is completely integrated into the RobotStudio user interface and takes full advantage of the user interface elements such as tabs, browsers, and 3D graphics.

Visual SafeMove is enabled for robots with the safety module. It offers an intuitive way to visualize and configure safety zones. Zones can be adjusted by direct manipulation in the 3D window. Users with previous experience from SafeMove will recognize the same terminology used as before.

Visual SafeMove is used to configure safety stops. For this purpose, the SafeMove options are not required, that is, this functionality is available for all robots. More information about the configuration is available in the product manual for the robot controller.

Visual SafeMove works both with the real controller and the virtual controller. For a virtual controller, a RobotStudio station should be used, which allows zones to be generated automatically. When not running a RobotStudio station, **Online Monitor** is used to visualize the robot.

Starting Visual SafeMove

	Action
1	Start RobotStudio with a virtual controller (with or without a station) or connect a real controller. <ul style="list-style-type: none">The user account logging in the controller must be granted with the Safety Services permission.The write access to the controller is also requested
2	In the Controller tab, click Online Monitor . (Not needed when running a RobotStudio station.)
3	In the Controller tab, click Safety , then select Visual SafeMove .

Configuring SafeMove

Configuring pre logic

- 1 On the **Visual SafeMove** tab page, click **Safe IO Configurator** in the **Configuration** group.
- 2 Click **Pre Logic** view in the **Safe IO Configuration** page.
- 3 Click **New expression** and create the following expressions.
 - ISH_Activate_SST
 - ISH_Activate_TSP
 - ISH_Delay_SST

Continues on next page

3 Installation and commissioning

3.6.5 Configuration of SafeMove using Visual SafeMove in RobotStudio

Continued

- ISH_Delay_TSP
- ISH_EnableDelay_Protecting
- ISH_EnableDelay_Warning
- ISH_Combination_Protecting
- ISH_Combination_Waning

In which, the expressions *ISH_Combination_Protecting* and *ISH_Combination_Waning* are required only when two PROFIsafe-based laser scanners are connected.

- 4 At the bottom of the **Safe IO Configuration** page, type the corresponding logical expression in the text box for each expression and click **Create signals**.

Expression	Logic
ISH_Activate_SST	Valid for scenarios with 1 PROFIsafe-based laser scanner connected ISH_Supervise_SST := ((NOT EDGE((NOT ProtectingArea1),ISH_Delayed_SST)) OR (NOT ISH_Enabler_Delay_SST))
	Valid for scenarios with 2 PROFIsafe-based laser scanners connected ISH_Supervise_SST := ((NOT EDGE((NOT ProtectingAreaSM),ISH_Delayed_SST)) OR (NOT ISH_Enabler_Delay_SST))
ISH_Activate_TSP	Valid for scenarios with 1 PROFIsafe-based laser scanner connected ISH_Supervise_TSP := ((NOT EDGE((NOT WarningArea1),ISH_Delayed_TSP)) OR (NOT ISH_Enabler_Delay_TSP))
	Valid for scenarios with 2 PROFIsafe-based laser scanners connected ISH_Supervise_TSP := ((NOT EDGE((NOT WarningAreaSM),ISH_Delayed_TSP)) OR (NOT ISH_Enabler_Delay_TSP))
ISH_Delay_SST	Valid for scenarios with 1 PROFIsafe-based laser scanner connected DELAY(ISH_Enabler_Delay_SST,ProtectingArea1,(ISH_AtUser_Period_ms_Until_SST / ISH_SMctrl_Frequency),ISH_Count-Delay_SST,ISH_Delayed_SST)
	Valid for scenarios with 2 PROFIsafe-based laser scanners connected DELAY(ISH_Enabler_Delay_SST,ProtectingAreaSM,(ISH_AtUser_Period_ms_Until_SST / ISH_SMctrl_Frequency),ISH_Count-Delay_SST,ISH_Delayed_SST)

Continues on next page

Expression	Logic
ISH_Delay_TSP	Valid for scenarios with 1 PROFIsafe-based laser scanner connected DELAY(ISH_Enabler_Delay_TSP,WarningArea1,(ISH_AtUser_Period_ms_Until_TSP / ISH_SMctrl_Frequency),ISH_Count-Delay_TSP,ISH_Delayed_TSP)
	Valid for scenarios with 2 PROFIsafe-based laser scanners connected DELAY(ISH_Enabler_Delay_TSP,WarningAreaSM,(ISH_AtUser_Period_ms_Until_TSP / ISH_SMctrl_Frequency),ISH_Count-Delay_TSP,ISH_Delayed_TSP)
ISH_EnableDelay_Protecting ⁱ	ISH_Enabler_Delay_SST := (NOT ISH_UserMODE_bNot_IntermitCollab)
ISH_EnableDelay_Warning ⁱ	ISH_Enabler_Delay_TSP := ((NOT ISH_UserMODE_bNot_Cooperation) OR (NOT ISH_UserMODE_bNot_IntermitCollab))
ISH_Combination_Protecting ⁱⁱ	ProtectingAreaSM := (ProtectingArea1 AND ProtectingArea2)
ISH_Combination_Warning ⁱⁱ	WarningAreaSM := (WarningArea1 AND WarningArea2)

ⁱ Required no matter one or two PROFIsafe-based laser scanners are connected.

ⁱⁱ Required only when two PROFIsafe-based laser scanners are connected.

- 5 Click **Signals** view in the **Safe IO Configuration** page and then click **Global signals** to expand the signal list.
- 6 Click on the **Create new signal** row and create the following signals.
 - ISH_TFO_Active
 - ISH_TSP_Active
 - ISH_TSP_Viol
 - ISH_SST_Active
 - ISH_SST_Viol
- 7 Change the default value of following signals.

Signal	Default value
ISH_AtUser_Period_ms_Until_SST	650
ISH_AtUser_Period_ms_Until_TSP	550
ISH_SMctrl_Frequency	4
ISH_UserMODE_bNot_Cooperation	1

Creating encapsulation

- 1 In the **Visual SafeMove** browser on the left pane of the window, select the robot (ROB_1) and click **Capsule** in the **Visual SafeMove** ribbon tab to create two capsule geometries for the robot.

Continues on next page

3 Installation and commissioning

3.6.5 Configuration of SafeMove using Visual SafeMove in RobotStudio

Continued

- 2 Set capsule properties for the robot.

Parameter		Value	
		Capsule 1	Capsule 2
Radius (mm)		160.000	140.000
Length (mm)		228.859	141.421
Start (Flange coordinates) (mm)	X value	-30.356	380.000
	Y value	-22.120	30.000
	Z value	30.485	150.000
End (Flange coordinates) (mm)	X value	186.565	520.000
	Y value	0	10.000
	Z value	100.000	150.000

- 3 In the **Visual SafeMove** browser, select the tool and click **Capsule** in the **Visual SafeMove** ribbon tab.
- 4 Set capsule properties for the tool.

Parameter		Value
Radius (mm)		75
Length (mm)		250
Start (Flange coordinates) (mm)	X value	0
	Y value	0
	Z value	0
End (Flange coordinates) (mm)	X value	0
	Y value	250
	Z value	250

Configuring Cyclic Brake Check

- 1 In the **Visual SafeMove** ribbon tab, click **Cyclic Brake Check**.
- 2 Select the **Warning only, no stop** check box, enable CBC for all the joints, and set other cyclic brake check properties.

Parameter	Value
Max CRC test interval (h)	48
Pre warning time (h)	6
Standstill tolerance	2
Supervision threshold	0.02

Configuring the supervision functions

- 1 In the **Visual SafeMove** ribbon tab, choose **Create Safe Zone** from the **Safe Zone** list.
- 2 Create three zones and rename as follows:
 - **Transient_Contact_Zone**
 - **Quasi_Static_Contact_Zone_1**

Continues on next page

- Quasi_Static_Contact_Zone_2

3 Set zone properties.



Note

All the parameter values provided in this section are for reference only. The values shall be modified according to actual requirements and based on risk assessment of the final application.

Parameter		Value ⁱ		
		Transi-ent_Contact_Zone	Quasi_Stat-ic_Contact_Zone_1	Quasi_Stat-ic_Contact_Zone_2
Tool Speed Supervision Priority		BASE	BASE	BASE
Reference		Task frame	Task frame	Task frame
Bottom, Top (mm)	Bottom value	50.000	-100.000	0.000
	Top value	2000.000	50.000	350.000
Vertices X, Y (mm)	X and Y values for vertices 1	-1500, -1500	-1600, -1600	-100, -200
	X and Y values for vertices 2	1500, -1500	1600, -1600	100, -200
	X and Y values for vertices 3	1500, 1500	1600, 1600	100, 150
	X and Y values for vertices 4	-1500, 1500	-1600, 1600	-100, 150

ⁱ Values for safe zone dimension are for reference only. It is allowed to customize the safe zone scope according to actual requirements. All the changes should be based on risk assessment of the final application.

4 Right click the three zones respectively in the left navigation tree and choose **Tool Speed Supervision**. Set following parameters.

Parameter		Value		
		Transi-ent_Contact_Zone	Quasi_Stat-ic_Contact_Zone_1	Quasi_Stat-ic_Contact_Zone_2
Violation action	Stop category	Cat-egory1Stop	Cat-egory1Stop	Cat-egory1Stop
Speed limits	Max speed (mm/s)	434.000	20.000	20.000

5 Right click the Quasi_Static_Contact_Zone_1 and Quasi_Static_Contact_Zone_2 zones respectively in the left navigation tree and choose **Tool Force Supervision**. Set following parameters.

Parameter		Value
Violation action	Stop category	Category1Stop
Force limits	Max force (N)	70.000

Continues on next page

3 Installation and commissioning

3.6.5 Configuration of SafeMove using Visual SafeMove in RobotStudio

Continued

- 6 Click **Tool Position Supervision** in the **Modify** ribbon tab and set the properties.

Parameter		Value
Activation		PermanentlyActive
Function active status		No signal
Violation action	Stop category	Category1Stop
	Signal	No signal
Settings		Checked the Include upper arm geometry and Allow inside check boxes .

- 7 In the **Visual SafeMove** browser, right-click **Tool Speed Supervisions** and choose **Create Global Tool Speed Supervision**.

Parameter		Value
Activation		ISH_Supervise_TSP
Function active status		ISH_TSP_Active
Violation action	Stop category	Category1Stop
	Signal	ISH_TSP_Viol
Settings	Max speed (mm/s)	250.000
	Min speed (mm/s)	Leave blank

- 8 In the **Visual SafeMove** browser, right-click **Stand Still Supervisions** and choose **Create Global Stand Still Supervision**.

Parameter		Value
Activation		ISH_Supervise_SST
Function active status		ISH_SST_Active
Violation action	Stop category	Category0Stop
	Signal	ISH_SST_Viol
Tolerances		Enabled for all joints and remain default tolerance values.

Uploading the settings to the controller

- 1 In the **Visual SafeMove** ribbon tab, click **Controller** in the **Configuration** group.
- 2 Click **Write to controller**.

The configurations are uploaded to the controller after the controller restarts.

3.6.6 Information about Collaborative Speed Control add-in

Overview



Note

The Collaborative Speed Control add-in is required only for robots operating in RobotWare 7.6 or later.

The Collaborative Speed Control add-in is integrated in the robot system at delivery if any of laser scanner options 3351-X are ordered. It is also available separately in the add-ins section in RobotStudio. To add it to an existing controller or do an update, see the installation procedure to install and add it to the robot.

With the Collaborative Speed Control add-in installed, the speed control configuration is activated for the robot.

For PROFIsafe-based scenarios where a PLC is connected to act as a master and SafetyIO-based scenarios, after the add-in is installed, a predefined template SafeMove configuration file is also available for easy configuration of basic SafeMove functions.

Installing the Collaborative Speed Control add-in

Perform the following procedure to install the Collaborative Speed Control add-in:

- 1 Start RobotStudio and open the **Add-Ins** tab. The **Gallery** window is displayed.
- 2 In the displayed **Gallery** window, use the **Search** function or **Common tags** to find the Collaborative Speed Control add-in.
- 3 Click the displayed add-in icon.
- 4 In the right pane, click **Add**.
The package is automatically installed and listed in the **Add-in** navigation tree in the left pane of the window.
- 5 In the **Controller** tab page, choose **Installation Manager 7** from the **Installation Manager** list in the **Configuration** group.
- 6 In the **Installation Manager** window, connect to a real controller or select/create a virtual controller.
- 7 Proceed to the **Options** window and access the **Applications** tab page.
- 8 In the **Collaborative Features** group, choose the required option checkbox.
- 9 Click **Next** to go to the **Confirmation** window.
- 10 Select **Apply** to confirm and save the changes.

The add-in is displayed in the controller overview if it is successfully added to the controller.

3 Installation and commissioning

3.6.7.1 Configuration of one PROFINET-base laser scanner (RobotWare 7.5 or earlier)

3.6.7 Speed control

3.6.7.1 Configuration of one PROFINET-base laser scanner (RobotWare 7.5 or earlier)

Preparing the robot system

Required options for system setup

When setting up the system using **Installation Manager** in RobotStudio, select the options [3020-2] *PROFINET Device*, [3023-2] *PROFIsafe Device* and [3043-3] *SafeMove Collaborative*, and the correct robot variant. The option *Drive System IRB Small Robot* is selected automatically after the robot type is determined.

Supported parameters for connections to scanner and PLC

Both the laser scanner and the PLC uses a PC-based software tool to configure the connection parameters that are used to connect to the OmniCore system. The supported parameters of the OmniCore system are predefined in the configuration file which could be loaded to after the Collaborative Speed Control add-in is installed, see [Information about Collaborative Speed Control add-in on page 141](#). The I/O configuration can be seen using I/O Engineering Tool in RobotStudio.

The following list shows the configuration parameters. They need to be correctly configured in the software tools to enable communication between the scanner, PLC, and OmniCore system.

- After the robot system is set up, the default IP address of the WAN port is automatically configured as 192.168.10.10/24. Make sure the scanner and PLC are also configured in the 192.168.10.XXX segment.
- In RobotStudio, open the configuration editor: Controller > Configuration > I/O Engineering Tool, and get the:
 - PROFIsafe parameter values

Device slot	Parameter	Value
SDO	Source address	2
SDO	Destination address	3
SDI	Source address	4
SDI	Destination address	5

- device mapping information

Signal name	Device mapping (default)	Category	Device	Device slot
ProtectingArea	64	ProfiSafe	OmniCore_Internal	SDI
WarningArea	65	ProfiSafe	OmniCore_Internal	SDI
ProtectingAreaSST	66	ProfiSafe	OmniCore_Internal	SDI
WarningAreaTSP	67	ProfiSafe	OmniCore_Internal	SDI
SafetyCommunicationEnable	68	ProfiSafe	OmniCore_Internal	SDI

Continues on next page

- The PROFINET device name of the controller must be set to *omnicoreprofisafe*.



Tip

Previous device mapping information is based on the default setting that is configured with 8 byte DI, 8 byte DO, 8 byte SDI and 8 byte SDO. The LED control module needs to occupy 5 bits in the 8 byte SDI for the signals.

If the 8 byte DI is insufficient for the actual application, users can delete the default DI device slot and add a larger one, then, reallocate the device mapping addresses to the five signals. The signal names and corresponding functions must be the same as that defined in the default setting. This is to make sure that the LED control module can still work properly.

Take the expansion to 256 byte DI and 256 byte DO as an example. If the user expands both DI and DO to 256 byte, the possible device mapping addresses for the ProtectingArea, WarningArea, ProtectingAreaSST, WarningAreaTSP and SafetyCommunicationEnable signals in 8 byte SDI device slot should be 2048, 2049, 2050, 2051 and 2052, respectively.

GSD file

The GSD file, *GSDML-V2.xx-ABB-Robotics-OmniCore-YYYYMMDD.xml*, can be obtained from the RobotStudio or the OmniCore controller.

- **In the RobotWare installation folder in RobotStudio:**
...*DistributionPackages\ABB.RobotWare-x.x.x-xxx\RobotPackages\RobotControl_x.x.xxx\utility\service\GSDML*
- **On the OmniCore Controller:**
...*products\RobotControl_x.x.x\utility\service\GSDML*

3 Installation and commissioning

3.6.7.1 Configuration of one PROFINET-base laser scanner (RobotWare 7.5 or earlier)

Continued

Configuring the laser scanner

Protection fields

Four protection fields are defined to provide a progressive safety protection. The following figure illustrates the field ranges.

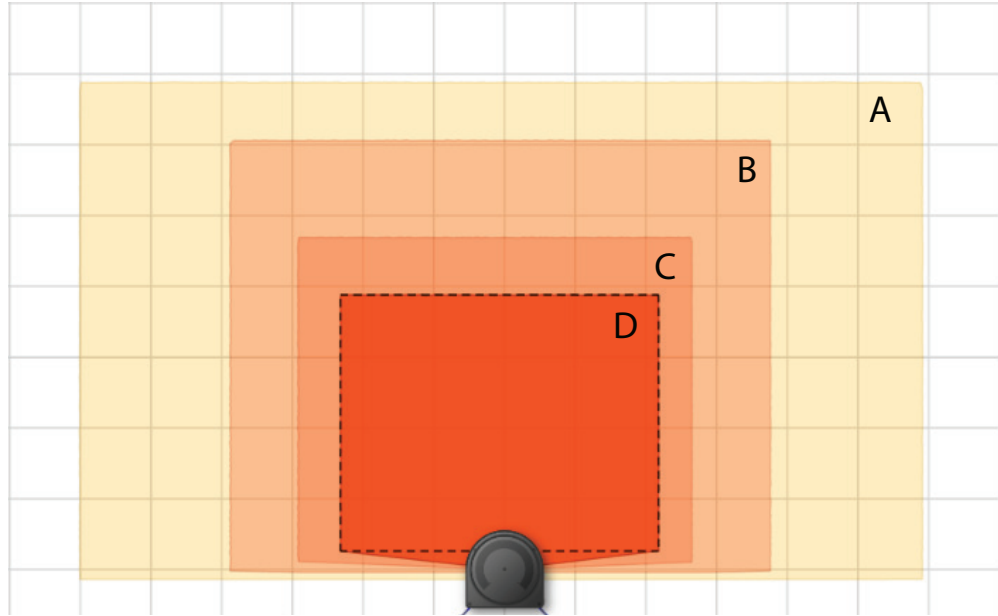

xx210000165

	Field	Device mapping (default)	Lamp color	Description
A	WarningArea	65	Yellow	The warning area field defines the largest range, but it shall be within the scanning range of the scanner. Within in this field range, the lamp unit on the process hub lights up yellow, and the robot movement speed reduces to a lower speed that is set by the user.
B	WarningAreaTSP	67	Yellow	Within in this field range, the lamp unit still lights up yellow, but Tool Speed Supervision (TSP) is enabled. If the robot moves in the speed that is out of the defined range for TSP, the motor is off. For details about TSP, see <i>Application manual - Functional safety and SafeMove</i> .
C	ProtectingArea	64	Red	Within this field range, the lamp unit turns to red and the robot movement speed is reduced to 0. The robot stands still.

Continues on next page

	Field	Device mapping (default)	Lamp color	Description
D	ProtectingAreaSST	66	Red	<p>The protecting stop SST field defines the smallest range. However, this range shall be larger than the minimum stopping distance on the basis of the response time for a small scanning cycle time. For details about how to calculate the range, see the user manual from the vendor. For details about the stopping distance and response time, see <i>Product specification - Robot stopping distances according to ISO 10218-1</i>.</p> <p>Within this field range, the lamp unit still lights up red, but Stand Still Supervision (SST) is enabled. If the robot axes move exceeding the maximum range setting in SST, the motor is off.</p> <p>For details about SST, see <i>Application manual - Functional safety and SafeMove</i>.</p>

Configuration procedure

Before starting the configuration, obtain the *microScan 3 Core - PROFINET GSDML* file and the software tool *Safety Designer®* from SICK's website first. Make sure both the file and the software tool are in the latest versions.

Detailed procedures about how to configure the laser scanner are detailed in *SICK microScan3 Siemens PLC integration instruction manual - TIA Portal* and *SICK microScan3 Siemens PLC integration instruction manual - SIMATIC Step 7*.

Following described roughly:

- 1 Connect the laser scanner to the PLC and controller.
See the physical connection in [Connecting the laser scanner\(s\) on page 92](#).
- 2 Open configuration software tool *Safety Designer®*.
- 3 Set IP address and PROFINET name in **Configuration > Addressing**.
 - The scanner IP address must be in the same network segment with the PLC and controller, that is, 192.168.10.XXX.
 - The PROFINET name must be the same in the PLC configuration.
- 4 Set **F-destination address** to 12 in PROFINET area in **Configuration > Protocol Settings**.
- 5 Define the four protection fields in **Configuration > Fields**.
- 6 Define the source for input signals of the scanner and configure basic settings for the inputs and outputs in **Configuration > Inputs and outputs**.
The **Use one input source** checkbox must be selected and choose **Rx: Process image (6 Bytes)** from the drop-down list.
- 7 Create monitoring cases and assign the fields that are to be monitored to each monitoring cases in **Configuration > Monitoring cases**.

Continues on next page

3 Installation and commissioning

3.6.7.1 Configuration of one PROFINET-base laser scanner (RobotWare 7.5 or earlier)

Continued

Configuring the PLC

The safety PLC connecting to the laser scanner and controller must support PROFIsafe and can act as a master. Before configuration, make sure the PLC is loaded with the GSD files of the controller and laser scanner.

Detailed procedures about how to add an external device to the PLC and how to configure detailed settings, see the user manual from the vendor. Following lists the necessary settings during PLC configuration:

- Add the scanner to the PLC by adding a **mS3 6Byte In/Out PROFIsafe V2.6.1** module.

The parameters `f_dest_address` and `f_source_address` are set to 12 and 1, respectively.

- Add the controller to the PLC by adding the **DI 8 bytes, DO 8 bytes, SDI 8 bytes and SDO 8 bytes** modules.

The parameters `f_dest_address` and `f_source_address` for the SDI are set to 3 and 2, respectively, and for the SDO are set to 5 and 4, respectively.

- Make sure the address for the SDO signal is the first address of **SDO 8 bytes** slot.
- Create variables.

Name	Type	Example address ⁱ
ProtectingTrigger	Bool	%I3.0
WarningTrigger	Bool	%I4.1
ProtectingSSTTrigger	Bool	%I3.2
WarningTSPTTrigger	Bool	%I3.3
ProtectingArea	Bool	%Q68.0
WarningArea	Bool	%Q68.1
ProtectingAreaSST	Bool	%Q68.2
WarningAreaTSP	Bool	%Q68.3
SafetyCommunicationEnable	Bool	%Q68.4
ActivateScanner	Bool	%Q3.0

ⁱ %I3.X and %I4.X are the addresses of the laser scanner; %Q68.X is the address of the OmniCore controller.

%Q3.0 is for activating the monitoring cases of the laser scanner.

- Check the communication between the PLC and controller is well and activate the laser scanner; set up the communication between the laser scanner, PLC and OmniCore controller.

Configuring SafeMove

With RobotStudio

Basic steps for configuring SafeMove are as follows:

- 1 Make some initial preparations.
- 2 Configure system parameters.
- 3 Set the input and output size and name of the PROFINET internal device.

Continues on next page

3.6.7.1 Configuration of one PROFINET-base laser scanner (RobotWare 7.5 or earlier)

Continued

For CRB 15000, required settings for communication between laser scanner, PLC and OmniCore controller are predefined in the configuration file.

- 4 Set up safety user grants.
Users must have access grants to lock safety controller configurations, safety services and software synchronization.
- 5 Configure robot properties.
- 6 Configure the synchronization position.
- 7 Configure the SafeMove tool definitions.
- 8 Configure safe I/O signals.



Note

For the first time configuring safe I/O signals using **Visual SafeMove**, make sure the **I/O Engineering Tool** is opened first. In this case, the configured safe I/O signals can be displayed in the **Visual SafeMove** window.

- 9 Configure zones and/or ranges.
- 10 Configure the supervision functions.
Tool Speed Supervision (TSP) and Stand Still Supervision (SST) must be configured.
- 11 Configure other functions.
- 12 Load the configuration to the safety controller.
- 13 Restart the robot controller.

Detailed configuration procedures are specified in *Application manual - Functional safety and SafeMove*.

With FlexPendant

- 1 Log in the FlexPendant.
The user logging in must have access grants to lock safety controller configurations, safety services and software synchronization.
- 2 Tap **Settings** on the home page.
- 3 Tap **Safety Controller**.
- 4 Tap **Synchronization** in the left pane.
- 5 Jog the robot to match the **Actual Positions** values with the **Sync Positions** values. Make sure they are the same.
- 6 Tap **Synchronize**.

3 Installation and commissioning

3.6.7.2 Configuration of one PROFINET-based laser scanner (RobotWare 7.6 or later and PLC acting as Master)

3.6.7.2 Configuration of one PROFINET-based laser scanner (RobotWare 7.6 or later and PLC acting as Master)

Preparing the robot system

Required options for system setup

When setting up the system using **Installation Manager** in RobotStudio, select the options [3020-2] *PROFINET Device*, [3023-2] *PROFINET Device*, [3043-3] *SafeMove Collaborative* and [3051-1] *Profisafe Package*, and the correct robot variant. The option *Drive System IRB Small Robot* is selected automatically after the robot type is determined.

Supported parameters for connections to scanner and PLC

Both the laser scanner and the PLC uses a PC-based software tool to configure the connection parameters that are used to connect to the OmniCore system. The supported parameters of the OmniCore system are predefined in the configuration file which could be loaded after the Collaborative Speed Control add-in is installed, see [Information about Collaborative Speed Control add-in on page 141](#). The I/O configuration can be seen using I/O Engineering Tool in RobotStudio.

The following list shows the configuration parameters. They need to be correctly configured in the software tools to enable communication between the scanner, PLC, and OmniCore system.

- After the robot system is set up, the default IP address of the WAN port is automatically configured as 192.168.10.10/24. Make sure the scanner and PLC are also configured in the 192.168.10.XXX segment.
- In RobotStudio, open the configuration editor: Controller > Configuration > I/O Engineering Tool, and get the:
 - PROFINET parameter values

Device slot	Parameter	Value
SDI	Source address	4
SDI	Destination address	5

- device mapping information

Signal name	Device mapping (default)	Category	Device	Device slot
ProtectingArea	0	ProfiSafe	OmniCore_Internal	SDI
WarningArea	1	ProfiSafe	OmniCore_Internal	SDI
SafetyCommunicationEnable	2	ProfiSafe	OmniCore_Internal	SDI

- The PROFINET device name of the controller must be set to *omnicoreprofisafe*.

Continues on next page

3.6.7.2 Configuration of one PROFIsafe-based laser scanner (RobotWare 7.6 or later and PLC acting as Master)

Continued

GSD file

The GSD file, *GSDML-V2.xx-ABB-Robotics-OmniCore-YYYYMMDD.xml*, can be obtained from the RobotStudio or the OmniCore controller.

- **In the RobotWare installation folder in RobotStudio:**
`...\\DistributionPackages\\ABB.RobotWare-x.x.x-xxx\\RobotPackages\\RobotControl_x.x.xxx\\utility\\service\\GSDML\\`
- **On the OmniCore Controller:**
`...\\products\\RobotControl_x.x.x\\utility\\service\\GSDML\\`

Configuring the laser scanner

Protection fields

Two protection fields are defined to provide a progressive safety protection. The following figure illustrates the field ranges.

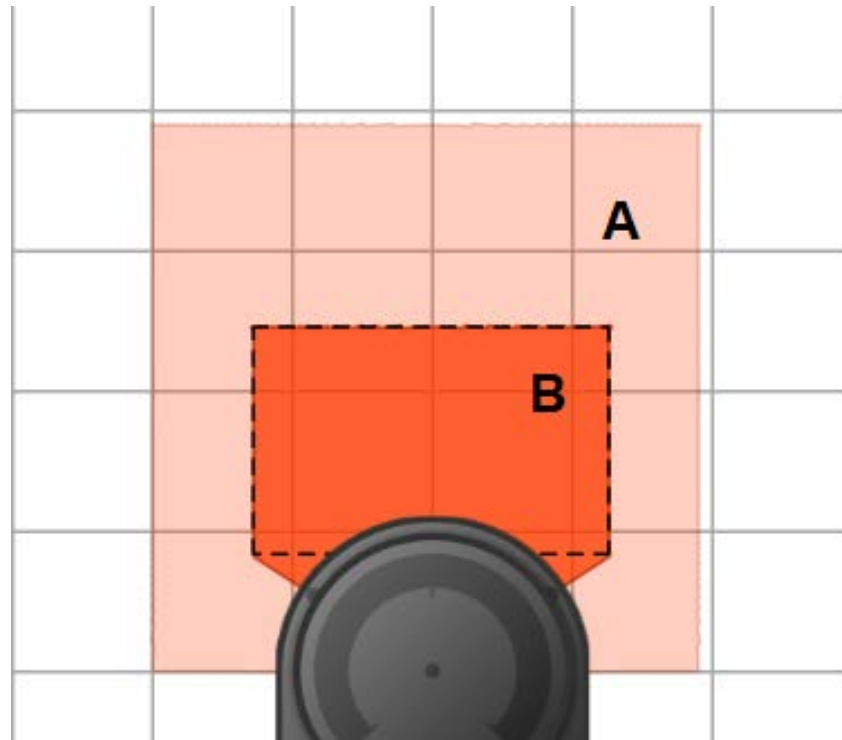

xx220000301

	Field	Device mapping (default)	Lamp color	Description
A	WarningArea	1	Yellow	The warning area field defines the largest range, but it shall be within the scanning range of the scanner. Within in this field range, the lamp unit on the process hub lights up yellow, and the robot movement speed reduces to a lower speed that is set by the user.
B	ProtectingArea	0	Red	Within this field range, the lamp unit turns to red and the robot movement speed is reduced to 0. The robot stands still.

Continues on next page

3 Installation and commissioning

3.6.7.2 Configuration of one PROFI-safe-based laser scanner (RobotWare 7.6 or later and PLC acting as Master)

Continued

Configuration procedure

Before starting the configuration, obtain the *microScan 3 Core - PROFINET GSDML* file and the software tool *Safety Designer®* from SICK's website first. Make sure both the file and the software tool are in the latest versions.

Detailed procedures about how to configure the laser scanner are detailed in *SICK microScan3 Siemens PLC integration instruction manual - TIA Portal* and *SICK microScan3 Siemens PLC integration instruction manual - SIMATIC Step 7*.

Following described roughly:

- 1 Connect the laser scanner to the PLC and controller.
See the physical connection in [Connecting the laser scanner\(s\) on page 92](#).
- 2 Open configuration software tool *Safety Designer®*.
- 3 Set IP address and PROFINET name in **Configuration > Addressing**.
 - The scanner IP address must be in the same network segment with the PLC and controller, that is, 192.168.10.XXX.
 - The PROFINET name must be the same in the PLC configuration.
- 4 Set **F-destination address** to 12 in PROFINET area in **Configuration > Protocol Settings**.
- 5 Define the two protection fields in **Configuration > Fields**.
- 6 Define the source for input signals of the scanner and configure basic settings for the inputs and outputs in **Configuration > Inputs and outputs**.
The **Use one input source** checkbox must be selected and choose **Rx: Process image (6 Bytes)** from the drop-down list.
- 7 Create monitoring cases and assign the fields that are to be monitored to each monitoring cases in **Configuration > Monitoring cases**.

Configuring the PLC

The safety PLC connecting to the laser scanner and controller must support PROFI-safe and can act as a master. Before configuration, make sure the PLC is loaded with the GSD files of the controller and laser scanner.

Detailed procedures about how to add an external device to the PLC and how to configure detailed settings, see the user manual from the vendor. Following lists the necessary settings during PLC configuration:

- Add the scanner to the PLC by adding a **mS3 6Byte In/Out PROFI-safe V2.6.1** module.
The parameters **f_dest_address** and **f_source_address** are set to 12 and 1, respectively.
- Add the controller to the PLC by adding the **DI 8 bytes, DO 8 bytes, SDI 8 bytes** and **SDO 8 bytes** modules.
The parameters **f_dest_address** and **f_source_address** for the SDI are set to 3 and 2, respectively, and for the SDO are set to 5 and 4, respectively.
- Make sure the address for the SDO signal is the first address of **SDO 8 bytes** slot.

Continues on next page

3.6.7.2 Configuration of one PROFIsafe-based laser scanner (RobotWare 7.6 or later and PLC acting as Master)

Continued

- Create variables.

Name	Type	Example address ⁱ
ProtectingTrigger	Bool	%I3.0
WarningTrigger	Bool	%I4.1
ProtectingArea	Bool	%Q68.0
WarningArea	Bool	%Q68.1
SafetyCommunicationEnable	Bool	%Q68.2
ActivateScanner	Bool	%Q3.0

ⁱ %I3.X and %I4.X are the addresses of the laser scanner; %Q68.X is the address of the OmniCore controller.
%Q3.0 is for activating the monitoring cases of the laser scanner.

- Check the communication between the PLC and controller is well and activate the laser scanner; set up the communication between the laser scanner, PLC and OmniCore controller.

Configuring SafeMove

To enable SafeMove, perform the following procedure:

- 1 Log in the FlexPendant.
Make sure the user logged in have access grants to lock safety controller configurations, safety services and software synchronization.
- 2 Tap **SafeMove** on the home page.
- 3 Tap **Load** in the pop-up message box to confirm loading of template SafeMove configuration files.
The controller restarts.
- 4 After the controller is restarted, tap **Settings** on the home page.
- 5 Tap **Safety Controller**.
- 6 Tap **Synchronization** in the left pane.
- 7 Jog the robot to match the **Actual Positions** values with the **Sync Positions** values.
Make sure the values are the same.
- 8 Tap **Synchronize**.

3 Installation and commissioning

3.6.7.3 Configuration of two PROFINET-based laser scanners (RobotWare 7.6 or later and PLC acting as Master)

3.6.7.3 Configuration of two PROFINET-based laser scanners (RobotWare 7.6 or later and PLC acting as Master)

Preparing the robot system

Required options for system setup

When setting up the system using **Installation Manager** in RobotStudio, select the options [3020-2] *PROFINET Device*, [3023-2] *PROFINET Device*, [3043-3] *SafeMove Collaborative* and [3051-3] *Dual Profisafe Package*, and the correct robot variant. The option *Drive System IRB Small Robot* is selected automatically after the robot type is determined.

Supported parameters for connections to scanners and PLC

Both laser scanners and the PLC uses a PC-based software tool to configure the connection parameters that are used to connect to the OmniCore system. The supported parameters of the OmniCore system are predefined in the configuration file which could be loaded after the Collaborative Speed Control add-in is installed, see [Information about Collaborative Speed Control add-in on page 141](#). The I/O configuration can be seen using I/O Engineering Tool in RobotStudio.

The following list shows the configuration parameters. They need to be correctly configured in the software tools to enable communication between the scanners, PLC, and OmniCore system.

- After the robot system is set up, the default IP address of the WAN port is automatically configured as 192.168.10.10/24. Make sure the scanners and PLC are also configured in the 192.168.10.XXX segment.
- In RobotStudio, open the configuration editor: Controller > Configuration > I/O Engineering Tool, and get the:
 - PROFINET parameter values

Device slot	Parameter	Value
SDI	Source address	4
SDI	Destination address	5

- device mapping information

Signal name	Device mapping (default)	Category	Device	Device slot
ProtectingArea	0	ProfiSafe	OmniCore_Internal	SDI
WarningArea	1	ProfiSafe	OmniCore_Internal	SDI
SafetyCommunicationEnable	2	ProfiSafe	OmniCore_Internal	SDI

- The PROFINET device name of the controller must be set to *omnicoreprofisafe*.

Continues on next page

3.6.7.3 Configuration of two PROFIsafe-based laser scanners (RobotWare 7.6 or later and PLC acting as Master)

Continued

GSD file

The GSD file, *GSDML-V2.xx-ABB-Robotics-OmniCore-YYYYMMDD.xml*, can be obtained from the RobotStudio or the OmniCore controller.

- **In the RobotWare installation folder in RobotStudio:**
`...\\DistributionPackages\\ABB.RobotWare-x.x.x-xxx\\RobotPackages\\RobotControl_x.x.xxx\\utility\\service\\GSDML\\`
- **On the OmniCore Controller:**
`...\\products\\RobotControl_x.x.x\\utility\\service\\GSDML\\`

Configuring the laser scanner

Protection fields

Two protection fields are defined to provide a progressive safety protection. The following figure illustrates the field ranges.

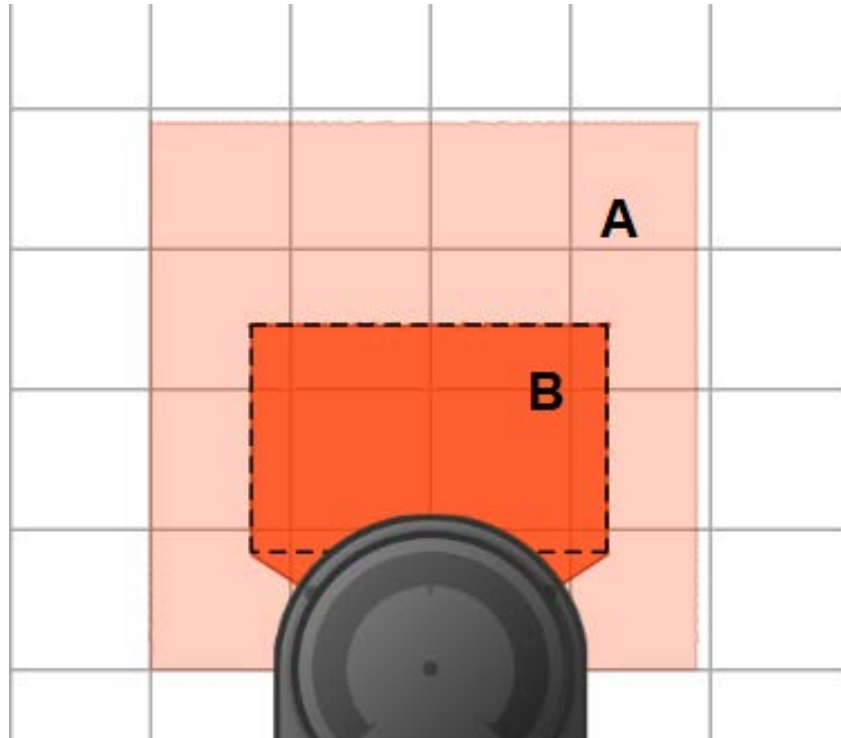

xx220000301

	Field	Device mapping (default)	Lamp color	Description
A	WarningArea	1	Yellow	The warning area field defines the largest range, but it shall be within the scanning range of the scanner. Within in this field range, the lamp unit on the process hub lights up yellow, and the robot movement speed reduces to a lower speed that is set by the user.
B	ProtectingArea	0	Red	Within this field range, the lamp unit turns to red and the robot movement speed is reduced to 0. The robot stands still.

Continues on next page

3 Installation and commissioning

3.6.7.3 Configuration of two PROFI-safe-based laser scanners (RobotWare 7.6 or later and PLC acting as Master)

Continued

Configuration procedure

Before starting the configuration, obtain the *microScan 3 Core - PROFINET GSDML* file and the software tool *Safety Designer®* from SICK's website first. Make sure both the file and the software tool are in the latest versions.

Detailed procedures about how to configure the laser scanners are detailed in *SICK microScan3 Siemens PLC integration instruction manual - TIA Portal* and *SICK microScan3 Siemens PLC integration instruction manual - SIMATIC Step 7*. Following described roughly:

- 1 Connect the laser scanners to the PLC and controller.
See the physical connection in [Connecting the laser scanner\(s\) on page 92](#).
- 2 Open configuration software tool *Safety Designer®*.
- 3 Set IP address, F-destination and PROFINET name in **Configuration > Addressing**.
 - The scanner IP address must be in the same network segment with the PLC and controller, that is, 192.168.10.XXX.
 - The PROFINET name must be the same in the PLC configuration.
 - The two scanners must be set to different IP address, F-destination and PROFINET name.
- 4 Set **F-destination address** to 12 for the first scanner and to 13 for the second scanner, in **PROFINET** area in **Configuration > Protocol Settings**.
- 5 Define the two protection fields for each scanners in **Configuration > Fields**.
- 6 Define the source for input signals of each scanner and configure basic settings for the inputs and outputs in **Configuration > Inputs and outputs**.
The **Use one input source** checkbox must be selected and choose **Rx: Process image (6 Bytes)** from the drop-down list.
- 7 Create monitoring cases and assign the fields that are to be monitored to each monitoring cases in **Configuration > Monitoring cases**.

Configuring the PLC

The safety PLC connecting to the laser scanners and controller must support PROFI-safe and can act as a master. Before configuration, make sure the PLC is loaded with the GSD files of the controller and laser scanners.

Detailed procedures about how to add an external device to the PLC and how to configure detailed settings, see the user manual from the vendor. Following lists the necessary settings during PLC configuration:

- Add two scanners to the PLC by adding two **mS3 6Byte In/Out PROFI-safe V2.6.1** modules.
 - The parameters **f_dest_address** and **f_source_address** are set to 12 and 1, for the first scanner, respectively.
 - The parameters **f_dest_address** and **f_source_address** are set to 13 and 1, for the second scanner, respectively.
- Add the controller to the PLC by adding the **DI 8 bytes, DO 8 bytes, SDI 8 bytes** and **SDO 8 bytes** modules.

Continues on next page

3.6.7.3 Configuration of two PROFIsafe-based laser scanners (RobotWare 7.6 or later and PLC acting as Master)

Continued

The parameters `f_dest_address` and `f_source_address` for the SDI are set to 3 and 2, respectively, and for the SDO are set to 5 and 4, respectively.

- Make sure the address for the SDO signal is the first address of **SDO 8 bytes** slot.
- Create variables.

Name	Type	Example address ⁱ
ProtectingTrigger	Bool	%I3.0
WarningTrigger	Bool	%I4.1
ProtectingTrigger1	Bool	%I14.0
WarningTrigger1	Bool	%I15.1
ProtectingArea ⁱⁱ	Bool	%Q68.0
WarningArea ⁱⁱⁱ	Bool	%Q68.1
SafetyCommunicationEnable	Bool	%Q68.2
ActivateScanner	Bool	%Q3.0
ActivateScanner1	Bool	%Q14.0

ⁱ %I3.X, %I4.X, %I14.X and %I15.X are the addresses of laser scanners; %Q68.X is the address of the OmniCore controller.

%Q3.0 and %Q14.0 are for activating the monitoring cases of the laser scanners.

ⁱⁱ Value of ProtectingArea depends on logic AND value of ProtectingTrigger and ProtectingTrigger1.

ⁱⁱⁱ Value of WarningArea depends on logic AND value of WarningTrigger and WarningTrigger1.

- Check the communication between the PLC and controller is well and activate the laser scanner; set up the communication between the laser scanner, PLC and OmniCore controller.

Configuring SafeMove

To enable SafeMove, perform the following procedure:

- 1 Log in the FlexPendant.
Make sure the user logged in have access grants to lock safety controller configurations, safety services and software synchronization.
- 2 Tap **SafeMove** on the home page.
- 3 Tap **Load** in the pop-up message box to confirm loading of template SafeMove configuration files.
The controller restarts.
- 4 After the controller is restarted, tap **Settings** on the home page.
- 5 Tap **Safety Controller**.
- 6 Tap **Synchronization** in the left pane.
- 7 Jog the robot to match the **Actual Positions** values with the **Sync Positions** values.
Make sure the values are the same.
- 8 Tap **Synchronize**.

3 Installation and commissioning

3.6.7.4 Configuration of one PROFIsafe-based laser scanner (RobotWare 7.10 or later and OmniCore acting as Master)

3.6.7.4 Configuration of one PROFIsafe-based laser scanner (RobotWare 7.10 or later and OmniCore acting as Master)

Preparing the robot system

Required options for system setup

When setting up the system using **Installation Manager** in RobotStudio, select the options [3020-1] PROFINET Controller, [3023-1] PROFIsafe Controller, [3043-3] SafeMove Collaborative and [3051-1] Profisafe Package, and the correct robot variant. The option *Drive System IRB Small Robot* is selected automatically after the robot type is determined.

Configuring supported parameters of the robot system

The laser scanner needs to use a PC-based software tool to configure the connection parameters that are used to connect to the OmniCore system. The supported parameters of the OmniCore system are configured using I/O Engineering Tool in RobotStudio. Use the following procedure to perform the configuration:

- 1 Start RobotStudio and connect the controller.
 - The user account logging in the controller must be granted with the Safety Services permission.
 - The write access to the controller is requested.

- 2 In the **Controller** tab, click **I/O Engineering**.

The **I/O Engineering** window is displayed.

- 3 In the **Configuration** tab page on the left pane of the window, right-click **PROFINET** under **I/O system** and select **Scan Network**.

The connected laser scanner is displayed.

- 4 Right-click on the laser scanner and choose **Add as**.

The laser scanner is added under **Controller** in the **Configuration** tab page.



Note

Two device names are displayed in the list by default. You shall right-click on the device name *mS3 12Byte In/Out PROFIsafe V2.6.1* and choose **Delete** to delete it. The name may vary according to the actual laser scanner connected.

- 5 Click the laser scanner with the asterisk(*) mark, and then in the **Device Catalog** tab page on the right pane of the window, double-click **mS3 6Byte In/Out PROFIsafe V2.6.1**.
- 6 In the displayed **Signal Editor** tab page, add signals with following settings.

Name	Type of Signal	Device Mapping ⁱ	Default value
ActiveDevice1	Digital Output	8	1
ProtectingArea1	Digital Input	17	0
WarningArea1	Digital Input	8	0

ⁱ The mappings are only for examples. Refer to the cut-off setting defined in the *Safety Designer* software and enter the actual value.

Continues on next page

3.6.7.4 Configuration of one PROFI-safe-based laser scanner (RobotWare 7.10 or later and OmniCore acting as Master)

Continued

A new device name *mS3 6Byte In/Out PROFI-safe V2.6.1* is displayed under the scanner in the **Configuration** tab page.

- 7 Click the new device name and check the settings in the **Properties** tab page on the right pane of the window.

Make sure the **Destination** value is the same as the **F-Destination** address value for the scanner in the *Safety Designer* software.

- 8 In the **I/O Engineering** tab, click **Cross Connections** in the **Configuration** group, and check the created signals.

Make sure the created signals are in the same name as the displayed signals.

- 9 In the **I/O Engineering** tab, click **Write Config** to write the configurations to the controller.

- 10 Restart the controller.

- 11 After the controller is restarted, check the laser scanner name in the RAPID program `InternalSpeedHandling_User` in task `T_ROB1`, and make sure it is consistent with the name that the user defines for the laser scanner.

If the names are inconsistent, use the following steps to modify:

- a In the **Controller** pane, double-click the RAPID program `InternalSpeedHandling_User` in task `T_ROB1`.

The RAPID program is displayed in the right pane.

- b Find the parameter *Scanner1* and modify its value to the user-defined laser scanner name.

Continues on next page

3 Installation and commissioning

3.6.7.4 Configuration of one PROFI-safe-based laser scanner (RobotWare 7.10 or later and OmniCore acting as Master)

Continued

Configuring the laser scanner

Protection fields

Two protection fields are defined to provide a progressive safety protection. The following figure illustrates the field ranges.

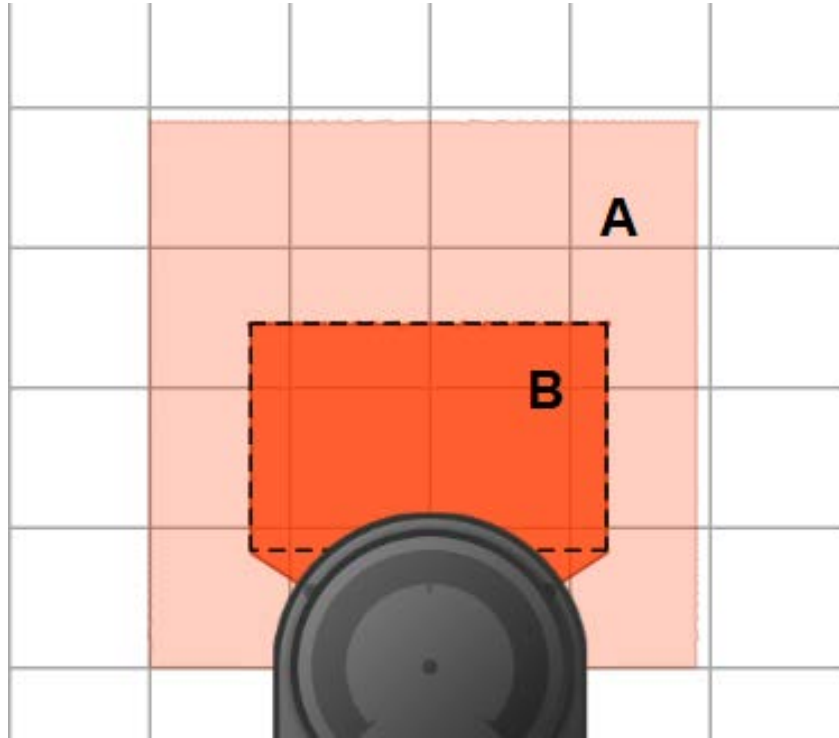

xx220000301

	Field	Device mapping (default)	Lamp color	Description
A	WarningArea	1	Yellow	The warning area field defines the largest range, but it shall be within the scanning range of the scanner. Within in this field range, the lamp unit on the process hub lights up yellow, and the robot movement speed reduces to a lower speed that is set by the user.
B	ProtectingArea	0	Red	Within this field range, the lamp unit turns to red and the robot movement speed is reduced to 0. The robot stands still.

Configuration procedure

Before starting the configuration, obtain the *microScan 3 Core - PROFINET GSDML* file and the software tool *Safety Designer®* from SICK's website first. Make sure both the file and the software tool are in the latest versions.

Detailed procedures about how to configure the laser scanner are detailed in *Operating instructions microScan3 - PROFINET*. Following described roughly:

- 1 Connect the laser scanner to the PC using a network cable.

See the physical connection in [Connecting the laser scanner\(s\) on page 92](#).

Continues on next page

3.6.7.4 Configuration of one PROFIsafe-based laser scanner (RobotWare 7.10 or later and OmniCore acting as Master)

Continued

- 2 Open configuration software tool *Safety Designer®*.
- 3 Set IP address and PROFINET name in **Configuration > Addressing**.
The scanner IP address must be in the same network segment with the controller, that is, 192.168.10.XXX.
- 4 Set **F-destination address** to 12 in **PROFINET** area in **Configuration > Protocol Settings**.
- 5 Define the two protection fields in **Configuration > Fields**.
- 6 Define the source for input signals of the scanner and configure basic settings for the inputs and outputs in **Configuration > Inputs and outputs**.
The **Use one input source** checkbox must be selected and choose **Rx: Process image (6 Bytes)** from the drop-down list.
- 7 Create monitoring cases and assign the fields that are to be monitored to each monitoring cases in **Configuration > Monitoring cases**.

Configuring SafeMove

To enable SafeMove, perform the following procedure:

- 1 Start RobotStudio and connect the controller.
 - The user account logging in the controller must be granted with the Safety Services permission.
 - The write access to the controller is requested.
- 2 In the **Controller** tab, click **Safety**, then select **Visual SafeMove**.
- 3 In the **Visual SafeMove** window, configure SafeMove function as instructed in [Configuration of SafeMove using Visual SafeMove in RobotStudio on page 135](#).

3 Installation and commissioning

3.6.7.5 Configuration of two PROFINET-based laser scanners (RobotWare 7.10 or later and OmniCore acting as Master)

3.6.7.5 Configuration of two PROFINET-based laser scanners (RobotWare 7.10 or later and OmniCore acting as Master)

Preparing the robot system

Required options for system setup

When setting up the system using **Installation Manager** in RobotStudio, select the options [3020-1] *PROFINET Controller*, [3023-1] *PROFINET Controller*, [3043-3] *SafeMove Collaborative* and [3051-3] *Dual Profisafe Package*, and the correct robot variant. The option *Drive System IRB Small Robot* is selected automatically after the robot type is determined.

Configuring supported parameters of the robot system

The laser scanners need to use a PC-based software tool to configure the connection parameters that are used to connect to the OmniCore system. The supported parameters of the OmniCore system are configured using I/O Engineering Tool in RobotStudio. Use the following procedure to perform the configuration:

- 1 Start RobotStudio and connect the controller.
 - The user account logging in the controller must be granted with the Safety Services permission.
 - The write access to the controller is requested.
- 2 In the **Controller** tab, click **I/O Engineering**.
The **I/O Engineering** window is displayed.
- 3 In the **Configuration** tab page on the left pane of the window, right-click **PROFINET** under **I/O system** and select **Scan Network**.
The connected laser scanners are displayed.
- 4 Right-click one of the laser scanners and choose **Add as**.
The laser scanner is added under **Controller** in the **Configuration** tab page.



Note

Two device names are displayed in the list by default. You shall right-click on the device name *mS3 12Byte In/Out PROFINET V2.6.1* and choose **Delete** to delete it. The name may vary according to the actual laser scanner connected.

- 5 Click the laser scanner with the asterisk(*) mark, and then in the **Device Catalog** tab page on the right pane of the window, double-click **mS3 6Byte In/Out PROFINET V2.6.1**.
- 6 In the displayed **Signal Editor** tab page, add signals with following settings.

Name	Type of Signal	Device Mapping ⁱ	Default value
ActiveDevice1	Digital Output	8	1
ProtectingArea1	Digital Input	17	0
WarningArea1	Digital Input	8	0

ⁱ The mappings are only for examples. Refer to the cut-off setting defined in the *Safety Designer* software and enter the actual value.

Continues on next page

3.6.7.5 Configuration of two PROFIsafe-based laser scanners (RobotWare 7.10 or later and OmniCore acting as Master)

Continued

A new device name *mS3 6Byte In/Out PROFIsafe V2.6.1* is displayed under the scanner in the **Configuration** tab page.

- 7 Click the new device name and check the settings in the **Properties** tab page on the right pane of the window.

Make sure the Destination value is the same as the F-Destination address value for the scanner in the *Safety Designer* software.

- 8 In the **I/O Engineering** tab, click **Cross Connections** in the **Configuration** group, and check the created signals.

Make sure the created signals are in the same name as the displayed signals.

- 9 Repeat steps 4 to 8 to add the other laser scanner, for which the signal settings shall be as follows.

Name	Type of Signal	Device Mapping ⁱ	Default value
ActiveDevice2	Digital Output	8	1
ProtectingArea2	Digital Input	17	0
WarningArea2	Digital Input	8	0

ⁱ The mappings are only for examples. Refer to the cut-off setting defined in the *Safety Designer* software and enter the actual value.

- 10 In the **I/O Engineering** tab, click **Write Config** to write the configurations to the controller.

- 11 Restart the controller.

- 12 After the controller is restarted, check the laser scanner name in RAPID program *InternalSpeedHandling_User* in task *T_ROB1*, and make sure it is consistent with the name that the user defines for the laser scanner.

If the names are inconsistent, use the following steps to modify:

- a In the **Controller** pane, double-click the RAPID program *InternalSpeedHandling_User* in task *T_ROB1*.

The RAPID program is displayed in the right pane.

- b Find the parameters *Scanner1* and *Scanner2*, and modify their values to the user-defined laser scanner names.

Continues on next page

3 Installation and commissioning

3.6.7.5 Configuration of two PROFI-safe-based laser scanners (RobotWare 7.10 or later and OmniCore acting as Master)

Continued

Configuring the laser scanner

Protection fields

Two protection fields are defined to provide a progressive safety protection. The following figure illustrates the field ranges.

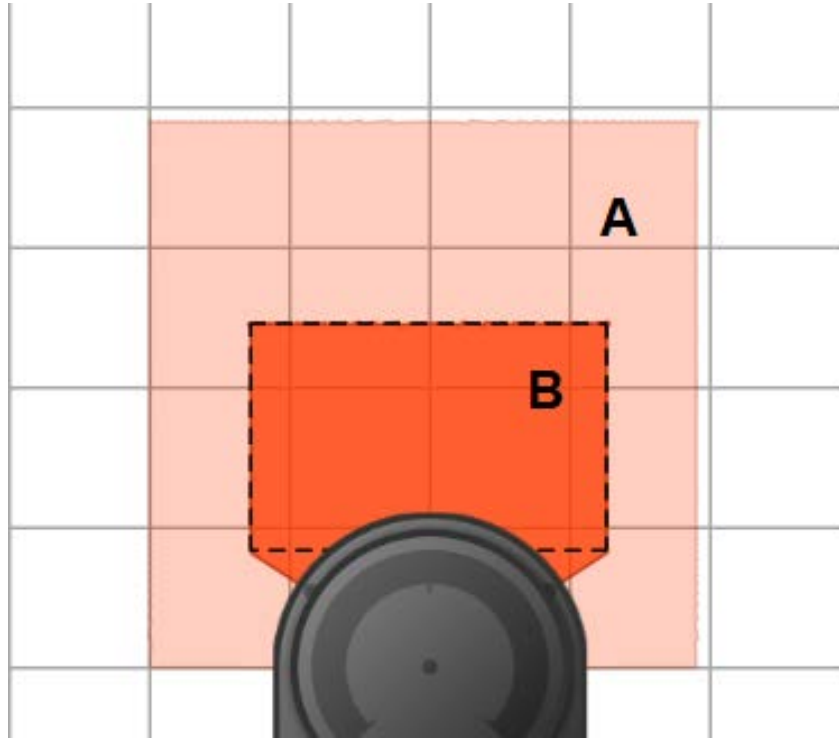

xx220000301

	Field	Device mapping (default)	Lamp color	Description
A	WarningArea	1	Yellow	The warning area field defines the largest range, but it shall be within the scanning range of the scanner. Within in this field range, the lamp unit on the process hub lights up yellow, and the robot movement speed reduces to a lower speed that is set by the user.
B	ProtectingArea	0	Red	Within this field range, the lamp unit turns to red and the robot movement speed is reduced to 0. The robot stands still.

Configuration procedure

Before starting the configuration, obtain the *microScan 3 Core - PROFINET GSDML* file and the software tool *Safety Designer®* from SICK's website first. Make sure both the file and the software tool are in the latest versions.

Detailed procedures about how to configure the laser scanner are detailed in *Operating instructions microScan3 - PROFINET*. Following described roughly:

- 1 Connect the laser scanner to the controller using a network cable.
See the physical connection in [Connecting the laser scanner\(s\) on page 92](#).

Continues on next page

3.6.7.5 Configuration of two PROFIsafe-based laser scanners (RobotWare 7.10 or later and OmniCore acting as Master)

Continued

- 2 Open configuration software tool *Safety Designer®*.
- 3 Set IP address, F-destination and PROFINET name in **Configuration > Addressing**.
 - The scanner IP address must be in the same network segment with the controller, that is, 192.168.10.XXX.
 - The two scanners must be set to different IP address, F-destination and PROFINET name.
- 4 Set **F-destination address** to **12** for the first scanner and to **13** for the second scanner, in **PROFINET** area in **Configuration > Protocol Settings**.
- 5 Define the two protection fields in **Configuration > Fields**.
- 6 Define the source for input signals of the scanner and configure basic settings for the inputs and outputs in **Configuration > Inputs and outputs**.

The **Use one input source** checkbox must be selected and choose **Rx: Process image (6 Bytes)** from the drop-down list.
- 7 Create monitoring cases and assign the fields that are to be monitored to each monitoring cases in **Configuration > Monitoring cases**.

Configuring SafeMove

To enable SafeMove, perform the following procedure:

- 1 Start RobotStudio and connect the controller.
 - The user account logging in the controller must be granted with the Safety Services permission.
 - The write access to the controller is requested.
- 2 In the **Controller** tab, click **Safety**, then select **Visual SafeMove**.
- 3 In the **Visual SafeMove** window, configure SafeMove function as instructed in [Configuration of SafeMove using Visual SafeMove in RobotStudio on page 135](#).

3 Installation and commissioning

3.6.7.6 Configuration of one SafetyIO-base laser scanner (RobotWare 7.6 or later)

3.6.7.6 Configuration of one SafetyIO-base laser scanner (RobotWare 7.6 or later)

Preparing the robot system

Required options for system setup

When setting up the system using **Installation Manager** in RobotStudio, select the options [3043-3] *SafeMove Collaborative* and [3051-2] *IO Package*, and the correct robot variant. The option *Drive System IRB Small Robot* is selected automatically after the robot type is determined.

Supported parameters for connections to scanners and scalable I/O device

The laser scanner uses a PC-based software tool to configure the connection parameters that are used to connect to the OmniCore system. The supported parameters of the OmniCore system are predefined in the configuration file which could be loaded to the system after the Collaborative Speed Control add-in is installed, see [Information about Collaborative Speed Control add-in on page 141](#).

The I/O configuration can be seen using I/O Engineering Tool in RobotStudio.

The following table lists the device mapping information of Scalable_IO signals, which are automatically configured after the add-in installation.

Signal name	Device mapping	Device
ABB_Scalable_IO_0_DI1 ⁱ	0	ABB_Scalable_IO
ABB_Scalable_IO_0_DI2 ⁱ	1	ABB_Scalable_IO
ABB_Scalable_IO_0_DI3 ⁱⁱ	2	ABB_Scalable_IO
ABB_Scalable_IO_0_DI4 ⁱⁱ	3	ABB_Scalable_IO

ⁱ Value of ProtectingArea depends on logic AND value of ABB_Scalable_IO_0_DI1 and ABB_Scalable_IO_0_DI2. For definition of ProtectingArea, see [Configuring the laser scanner on page 165](#).

ⁱⁱ Value of WarningArea depends on logic AND value of ABB_Scalable_IO_0_DI3 and ABB_Scalable_IO_0_DI4. For definition of WarningArea, see [Configuring the laser scanner on page 165](#).

Continues on next page

Configuring the laser scanner

Protection fields

Two protection fields are defined to provide a progressive safety protection. The following figure illustrates the field ranges.

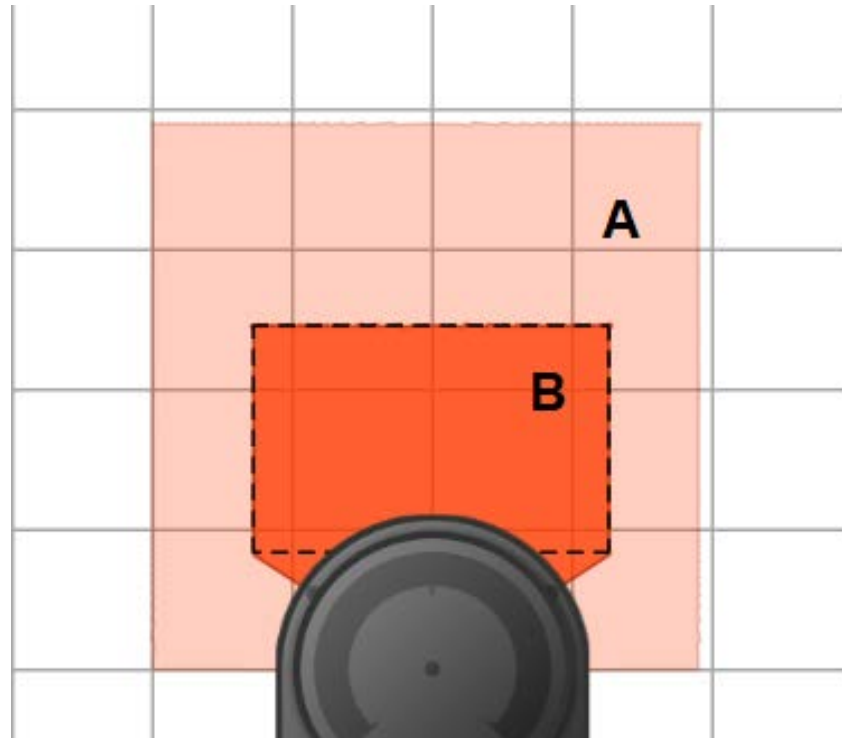

xx220000301

	Field	Lamp color	Description
A	WarningArea	Yellow	The warning area field defines the largest range, but it shall be within the scanning range of the scanner. Within in this field range, the lamp unit on the process hub lights up yellow, and the robot movement speed reduces to a lower speed that is set by the user.
B	ProtectingArea	Red	Within this field range, the lamp unit turns to red and the robot movement speed is reduced to 0. The robot stands still.

Configuration procedure

Before starting the configuration, obtain the software tool *Safety Designer®* from SICK's website first. Make sure the software tool is in the latest version.

Detailed procedures about how to configure the laser scanner are detailed in *Operating instructions microScan3 - Pro I/O* from the vendor. Following described the procedure roughly:

- 1 Open configuration software tool *Safety Designer®*.
- 2 Set IP address in **Configuration > Addressing**.

Make sure the scanner IP address is in the same network segment with the PC used for configuring the scanner.

Continues on next page

3 Installation and commissioning

3.6.7.6 Configuration of one SafetyIO-base laser scanner (RobotWare 7.6 or later)

Continued

- 3 Define the two protection fields for the scanner in **Configuration > Fields**.
- 4 Define the source for input signals of the scanner and configure basic settings for the inputs and outputs in **Configuration > Inputs and outputs**.
- 5 Select one OSSD pair from the **Signals** panel to pin1 and pin2, and select another OSSD pair to pin3 and pin4.

The two OSSD pairs will be used for defining the monitoring cases.

- 6 Create monitoring cases and assign the fields that are to be monitored to each monitoring cases in **Configuration > Monitoring cases**.
- 7 Refer to the following table to obtain the pins defined to OSSD pairs. The pins are from a 17-pin cable that will be used to connect the laser scanner and scalable I/O device.

Pin	Wiring color	Name	Function
1	Brown	OSSD1A	OSSD pair 1, OSSD A
2	Blue	OSSD1B	OSSD pair 1, OSSD B
3	White	OSSD2A	OSSD pair 2, OSSD A
4	Green	OSSD2B	OSSD pair 2, OSSD B
17	White with grey	0 V DC	0 DC

- 8 Connect the laser scanner to scalable I/O device with the defined pins.

Pin in cable	Pin position number in X2 connector of the device ⁱ
Pin1 (OSSD1A)	D101+
Pin2 (OSSD1B)	DI02+
Pin3 (OSSD2A)	DI03+
Pin4 (OSSD2B)	DI04+
Pin17	Circuit of D101-, D102-, D103- and D104-

ⁱ For detailed information of pin definitions in connector X2 Digital inputs of the scalable I/O device DSQC1042, see the product specification of the controller and *Application manual - Scalable I/O*.

Configuring the scalable I/O device

Detailed procedures about how to connect and configure the scalable I/O device DSQC1042 are specified in *Application manual - Scalable I/O*. Following provides a rough procedure:

- 1 Make sure that the laser scanner and scalable I/O device is connected as instructed in previous configuration procedure of laser scanner.
- 2 Connect the process power supply to connector X1 of the scalable I/O device via pin locations PWR DO and GND DO.
- 3 Connect the logic power supply to connector X4 of the scalable I/O device via pin locations PWR and GND.
- 4 Connect the Ethernet cable from the robot controller to connector X5.

Continues on next page

- 5 Log in the RobotStudio using the admin use account and configure the device to make sure the device communication works.

- a Click the **Controller** tab and, in the **Controller** pane, choose **I/O System > EtherNetIP**.

Information of three devices can be observed:

- CabinetIO is used for the I/O device DSQC1030, and the communication status is normal.

- ABB_Scalable_IO and ABB_Scalable_IO1 are used for the I/O device DSQC1042, and the communication status is abnormal.

- b Check the IP address and serial numbers associated with ABB_Scalable_IO and ABB_Scalable_IO1, which will display as follows.

Device name	IP address	Serial number
ABB_Scalable_IO	192.168.125.130	0
ABB_Scalable_IO1	192.168.125.131	Actual serial number of the device

- c Right-click **ABB_Scalable_IO1** and choose **Configure** from the shortcut menu.
- d In the displayed dialog box, choose the **Configure as replacement device** option and select **ABB_Scalable_IO** from the drop-down list.
- e Remove the texts in the **Create new I/O signals using name prefix** text box and then click **OK**.

Information of two devices can be observed, CabinetIO and ABB_Scalable_IO. Communication status of ABB_Scalable_IO will turn to normal after the SafeMove template file is uploaded using the SafeMove configurator app.



Note

The configuration could also be done using the I/O application in FlexPendant.



Note

If there are additional scalable I/O devices available, install and configure the additional devices by following the detailed procedures in *Application manual - Scalable I/O*.

Configuring SafeMove

To enable SafeMove, perform the following procedure:

- 1 Log in the FlexPendant.

Make sure the user logged in have access grants to lock safety controller configurations, safety services and software synchronization.

- 2 Tap **SafeMove** on the home page.

Continues on next page

3 Installation and commissioning

3.6.7.6 Configuration of one SafetyIO-base laser scanner (RobotWare 7.6 or later)

Continued

- 3 Tap **Load** in the pop-up message box to confirm loading of template SafeMove configuration files.

The controller restarts.

- 4 After the controller is restarted, tap **Settings** on the home page.
- 5 Tap **Safety Controller**.
- 6 Tap **Synchronization** in the left pane.
- 7 Jog the robot to match the **Actual Positions** values with the **Sync Positions** values.

Make sure the values are the same.

- 8 Tap **Synchronize**.

3.6.7.7 Configuration of two SafetyIO-base laser scanners (RobotWare 7.6 or later)

Preparing the robot system

Required options for system setup

When setting up the system using **Installation Manager** in RobotStudio, select the options [3043-3] *SafeMove Collaborative* and [3051-4] *Dual IO Package*, and the correct robot variant. The option *Drive System IRB Small Robot* is selected automatically after the robot type is determined.

Supported parameters for connections to scanners and scalable I/O device

The laser scanners use a PC-based software tool to configure the connection parameters that are used to connect to the OmniCore system. The supported parameters of the OmniCore system are predefined in the configuration file which could be loaded to the system after the Collaborative Speed Control add-in is installed, see [Information about Collaborative Speed Control add-in on page 141](#). The I/O configuration can be seen using I/O Engineering Tool in RobotStudio.

The following table lists the device mapping information of Scalable_IO signals, which are automatically configured after the add-in installation.

Signal name	Device mapping	Device
ABB_Scalable_IO_0_DI1 ⁱ	0	ABB_Scalable_IO
ABB_Scalable_IO_0_DI2 ⁱ	1	ABB_Scalable_IO
ABB_Scalable_IO_0_DI3 ⁱⁱ	2	ABB_Scalable_IO
ABB_Scalable_IO_0_DI4 ⁱⁱ	3	ABB_Scalable_IO
ABB_Scalable_IO_0_DI5 ⁱ	4	ABB_Scalable_IO
ABB_Scalable_IO_0_DI6 ⁱ	5	ABB_Scalable_IO
ABB_Scalable_IO_0_DI7 ⁱⁱ	6	ABB_Scalable_IO
ABB_Scalable_IO_0_DI8 ⁱⁱ	7	ABB_Scalable_IO

ⁱ Value of ProtectingArea depends on logic AND value of ABB_Scalable_IO_0_DI1, ABB_Scalable_IO_0_DI2, ABB_Scalable_IO_0_DI5 and ABB_Scalable_IO_0_DI6. For definition of ProtectingArea, see [Configuring the laser scanner on page 170](#).

ⁱⁱ Value of WarningArea depends on logic AND value of ABB_Scalable_IO_0_DI3, ABB_Scalable_IO_0_DI4, ABB_Scalable_IO_0_DI7 and ABB_Scalable_IO_0_DI8. For definition of WarningArea, see [Configuring the laser scanner on page 170](#).

Continues on next page

3 Installation and commissioning

3.6.7.7 Configuration of two SafetyIO-base laser scanners (RobotWare 7.6 or later)

Continued

Configuring the laser scanner

Protection fields

Two protection fields are defined to provide a progressive safety protection. The following figure illustrates the field ranges.

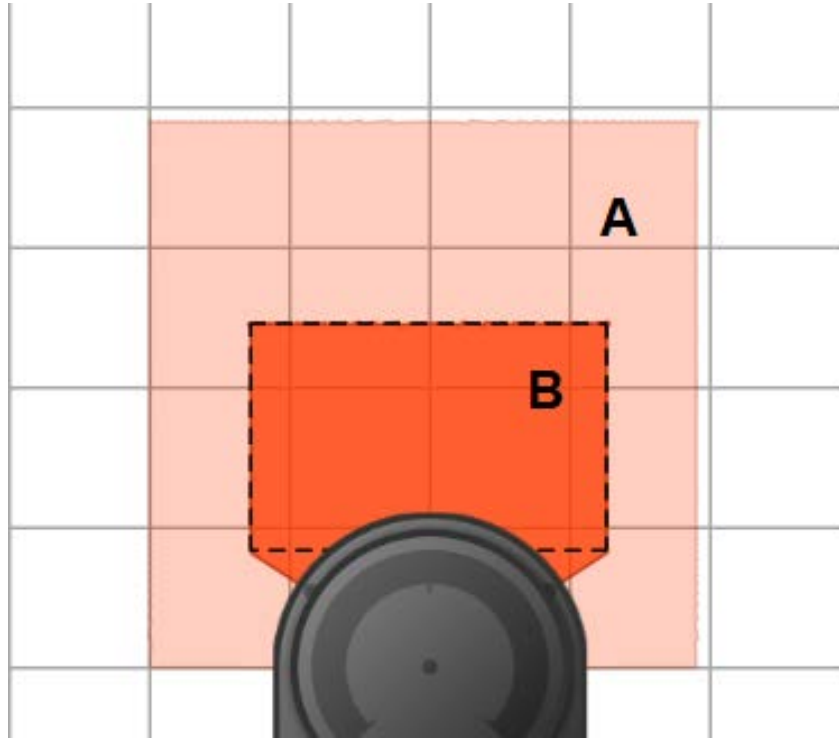

xx2200000301

	Field	Lamp color	Description
A	WarningArea	Yellow	The warning area field defines the largest range, but it shall be within the scanning range of the scanner. Within in this field range, the lamp unit on the process hub lights up yellow, and the robot movement speed reduces to a lower speed that is set by the user.
B	ProtectingArea	Red	Within this field range, the lamp unit turns to red and the robot movement speed is reduced to 0. The robot stands still.

Configuration procedure

Before starting the configuration, obtain the software tool *Safety Designer®* from SICK's website first. Make sure the software tool is in the latest version.

Detailed procedures about how to configure the laser scanners are detailed in *Operating instructions microScan3 - Pro I/O* from the vendor. Following described the procedure roughly:

- 1 Open configuration software tool *Safety Designer®*.
- 2 Set IP address in **Configuration > Addressing**.
 - Make sure the scanner IP addresses are in the same network segment with the PC used for configuring the scanner.

Continues on next page

- The two scanners must be set to different IP addresses.
- 3 Define the two protection fields for each scanner in **Configuration > Fields**.
 - 4 Define the source for input signals of each scanner and configure basic settings for the inputs and outputs in **Configuration > Inputs and outputs**.
 - 5 For both scanners, select one OSSD pair from the **Signals** panel to pin1 and pin2, and select another OSSD pair to pin3 and pin4.
The two OSSD pairs will be used for defining the monitoring cases.
 - 6 Create monitoring cases and assign the fields that are to be monitored to each monitoring cases in **Configuration > Monitoring cases**.
 - 7 Refer to the following table to obtain the pins defined to OSSD pairs. The pins are from a 17-pin cable that will be used to connect a laser scanner and scalable I/O device.

Pin	Wiring color	Name	Function
1	Brown	OSSD1A	OSSD pair 1, OSSD A
2	Blue	OSSD1B	OSSD pair 1, OSSD B
3	White	OSSD2A	OSSD pair 2, OSSD A
4	Green	OSSD2B	OSSD pair 2, OSSD B
17	White with grey	0 V DC	0 DC

- 8 Connect the laser scanners to safety module with the defined pins.

Scanner	Pin in cable	Pin position number in X2 connector of the device ⁱ
Scanner 1	Pin1 (OSSD1A)	D101+
	Pin2 (OSSD1B)	D102+
	Pin3 (OSSD2A)	D103+
	Pin4 (OSSD2B)	D104+
	Pin17	Circuit of D101-, D102-, D103- and D104-
Scanner 2	Pin1 (OSSD1A)	D105+
	Pin2 (OSSD1B)	D106+
	Pin3 (OSSD2A)	D107+
	Pin4 (OSSD2B)	D108+
	Pin17	Circuit of D105-, D106-, D107- and D108-

ⁱ For detailed information of pin definitions in connector X2 Digital inputs of the scalable I/O device DSQC1042, see the product specification of the controller and *Application manual - Scalable I/O*.

Configuring the scalable I/O device

Detailed procedures about how to connect and configure the scalable I/O device DSQC1042 are specified in *Application manual - Scalable I/O*. Following provides a rough procedure:

- 1 Make sure that the laser scanner and scalable I/O device is connected as instructed in previous configuration procedure of laser scanner.

Continues on next page

3 Installation and commissioning

3.6.7.7 Configuration of two SafetyIO-base laser scanners (RobotWare 7.6 or later)

Continued

- 2 Connect the process power supply to connector X1 of the scalable I/O device via pin locations PWR DO and GND DO.
- 3 Connect the logic power supply to connector X4 of the scalable I/O device via pin locations PWR and GND.
- 4 Connect the Ethernet cable from the robot controller to connector X5.
- 5 Log in the RobotStudio using the admin use account and configure the device to make sure the device communication works.

- a Click the **Controller** tab and, in the **Controller** pane, choose **I/O System > EtherNetIP**.

Information of three devices can be observed:

- CabinetIO is used for the I/O device DSQC1030, and the communication status is normal.
- ABB_Scalable_IO and ABB_Scalable_IO1 are used for the I/O device DSQC1042, and the communication status is abnormal.

- b Check the IP address and serial numbers associated with ABB_Scalable_IO and ABB_Scalable_IO1, which will display as follows.

Device name	IP address	Serial number
ABB_Scalable_IO	192.168.125.130	0
ABB_Scalable_IO1	192.168.125.131	Actual serial number of the device

- c Right-click **ABB_Scalable_IO1** and choose **Configure** from the shortcut menu.
- d In the displayed dialog box, choose the **Configure as replacement device** option and select **ABB_Scalable_IO** from the drop-down list.
- e Remove the texts in the **Create new I/O signals using name prefix** text box and then click **OK**.

Information of two devices can be observed, CabinetIO and ABB_Scalable_IO. Communication status of ABB_Scalable_IO will turn to normal after the SafeMove template file is uploaded using the SafeMove configurator app.



Note

The configuration could also be done using the I/O application in FlexPendant.



Note

If there are additional scalable I/O devices available, install and configure the additional devices by following the detailed procedures in *Application manual - Scalable I/O*.

Continues on next page

Configuring SafeMove

To enable SafeMove, perform the following procedure:

- 1 Log in the FlexPendant.

Make sure the user logged in have access grants to lock safety controller configurations, safety services and software synchronization.

- 2 Tap **SafeMove** on the home page.
- 3 Tap **Load** in the pop-up message box to confirm loading of template SafeMove configuration files.

The controller restarts.

- 4 After the controller is restarted, tap **Settings** on the home page.
- 5 Tap **Safety Controller**.
- 6 Tap **Synchronization** in the left pane.
- 7 Jog the robot to match the **Actual Positions** values with the **Sync Positions** values.

Make sure the values are the same.

- 8 Tap **Synchronize**.

3 Installation and commissioning

3.6.7.8 Speed control strategies

3.6.7.8 Speed control strategies

General

The speed control of CRB 15000 is affected by several factors, such as, the RobotWare version, the speed setting in the FlexPendant, the speed setting in motion instruction and the `SpeedRefresh` value. Users in different protection fields defined for laser scanner to monitor and perform different program execution actions may result in different movement speed. This section describes the speed control strategies for typical scenarios.

Strategies (RobotWare 7.5)

Users in Protecting area

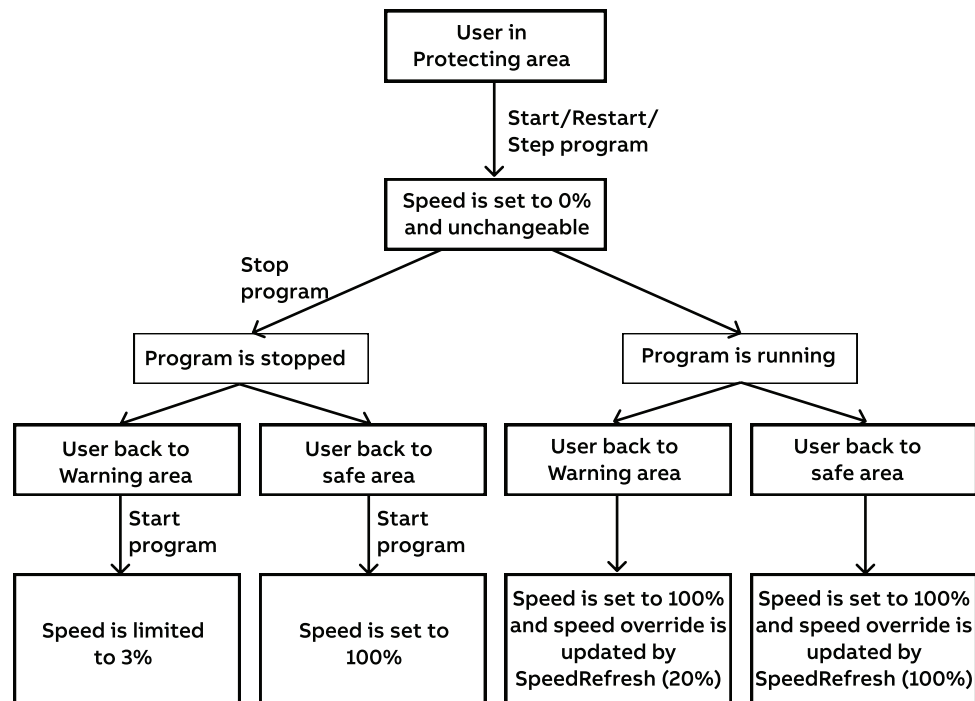

xx2100000512

Continues on next page

Users in Warning area

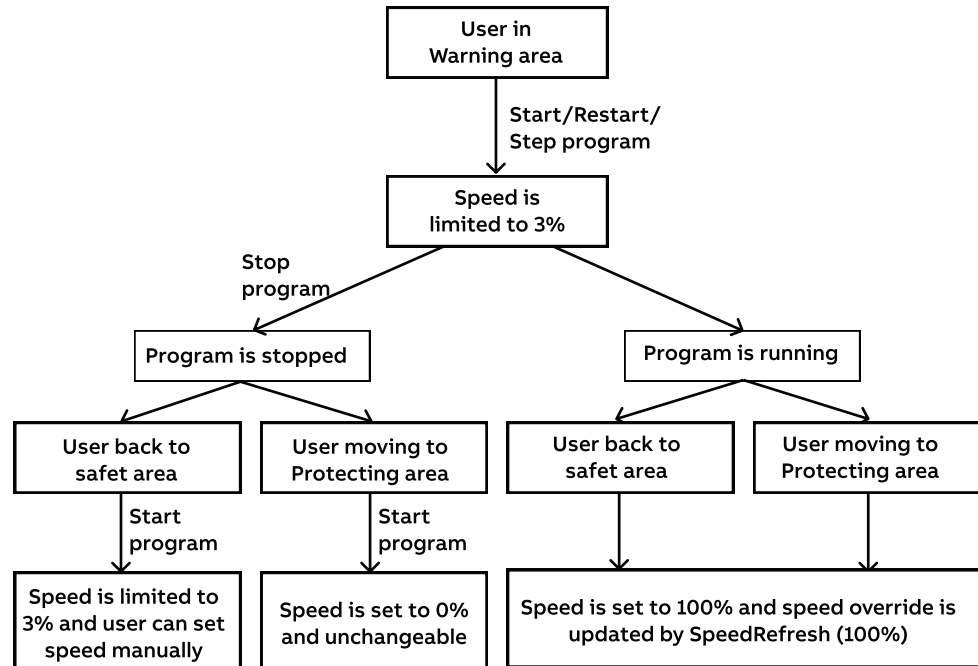

xx2100000513

SafeMove triggered but SST/TSP not configured

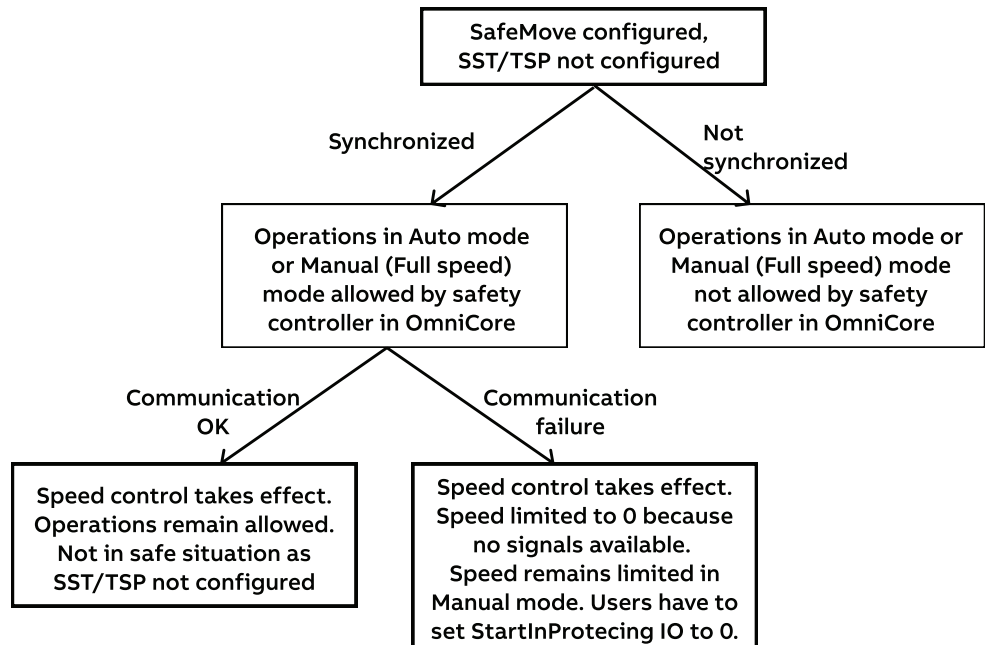

xx2100000514

Continues on next page

3 Installation and commissioning

3.6.7.8 Speed control strategies

Continued

Strategies (RobotWare 7.6 or later)

Users in Protecting area

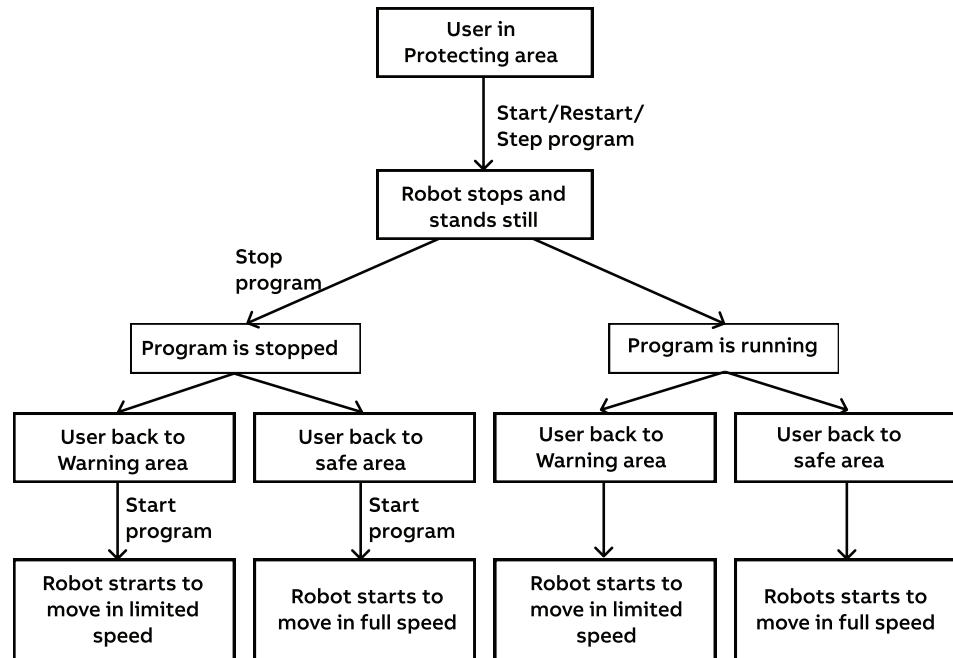

xx220000302

Users in Warning area

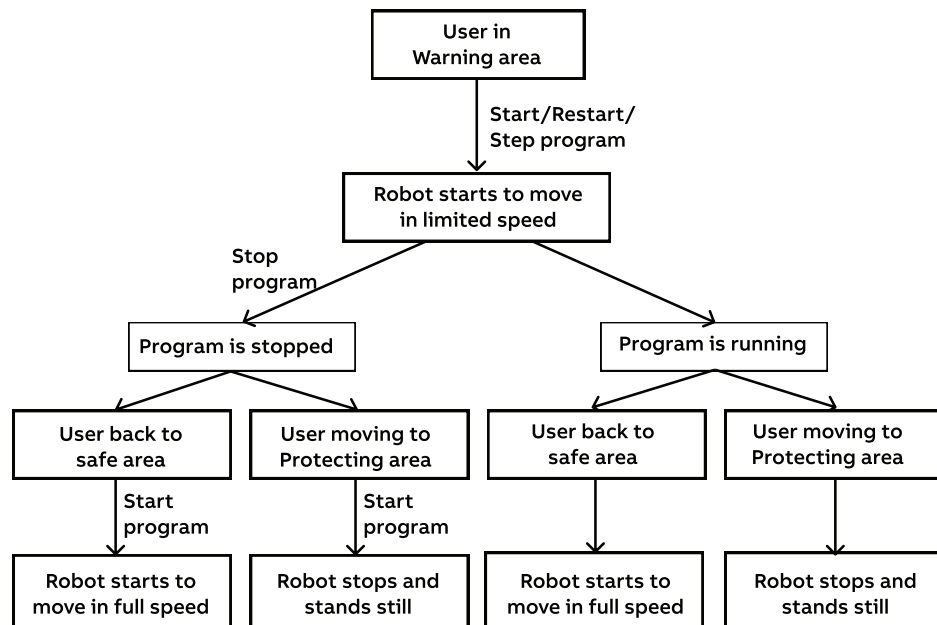

xx220000303

3.6.8 Use cases of safety configurations

General

Configurations of speed control are allowed to be modified in RAPID programs, which are loaded to the system after the Collaborative Speed Control add-in is installed.



Note

Safety configurations can only be modified for robots running in RobotWare 7.6 and later versions.

Modified configuration must always be validated to verify that the desired safety is achieved. If no validation is performed, or the validation is inadequate, the configuration cannot be relied on for personal safety.

Deactivating the SpeedHandling function



Note

Modified configuration must always be validated to verify that the desired safety is achieved. If no validation is performed, or the validation is inadequate, the configuration cannot be relied on for personal safety.

The SpeedHandling function is activated by default after the Collaborative Speed Control add-in is installed and the SafeMove template is loaded. The function is used to enable or disable speed-related actions for speed control.

It is possible to use the following procedure to deactivate the SpeedHandling function based on risk assessment of the final application:

- 1 In RobotStudio, open the RAPID program InternalSpeedHandling_User in task T_ROB1.
- 2 Navigate to the function ISH_b_FunctionalityIsUsed and set its value from default TRUE to FALSE.

```
T_ROB1/InternalSpeedHandling_User" x
49 ! In addition, the SafeMove Parameters must be set correctly!
50 ! Following Global-SafeMove-Signals need to be configured::
51 ! -> AtUser_PRODE_IsNot_Cooperation
52 ! -> AtUser_PRODE_IsNot_IntermitCollab
53 ! -> AtUser_Period_ms_Until_SST
54 ! -> AtUser_Period_ms_Until_TSP
55
56 ! DEFAULT is 250 mm/s, change according to the TSP max velocity set in SafeMove Configuration
57 TASK PERS num ISH_n_Speed_In_WarningArea_mm_s := 250;
58 ! DEFAULT is TRUE, set to FALSE to disable the InternalSpeedHandling completely
59 TASK PERS bool ISH_b_FunctionalityIsUsed := FALSE;
60 ! DEFAULT is TRUE, set to FALSE if you don't want to get Logs from the InternalSpeedHandling
61 TASK PERS bool ISH_b_ErrorLogShownIsUsed := TRUE;
62 ! DEFAULT is TRUE, set to FALSE if you don't want to get TPWrite notifications from the InternalSpeedHandling displayed
63 TASK PERS bool ISH_b_TPInformationIsUsed := TRUE;
64
```

xx2200000435

- 3 Save the change and apply to the controller.

SafeMove configurations also affect the speed control on the robot to achieve further safety. SafeMove is still functional after the SpeedHandling function in RAPID program is deactivated.

Continues on next page

3 Installation and commissioning

3.6.8 Use cases of safety configurations

Continued

Use the following procedure to disable the speed control function provided by SafeMove:

- 1 Open the RobotStudio.
- 2 Log in the controller using the Admin account and request the write access.
- 3 In the **Controller** tab, choose **Visual SafeMove** from the **Safety** group in the **Configuration** category.
- 4 In the **Visual SafeMove** tab, click **Safe IO Configurator** in the **Configuration** group.
- 5 In the displayed **Safe IO Configuration** window, go to the signal **ISH_UserMODE_bNot_IntemitCollab** in the global signal list and set the value to 1.

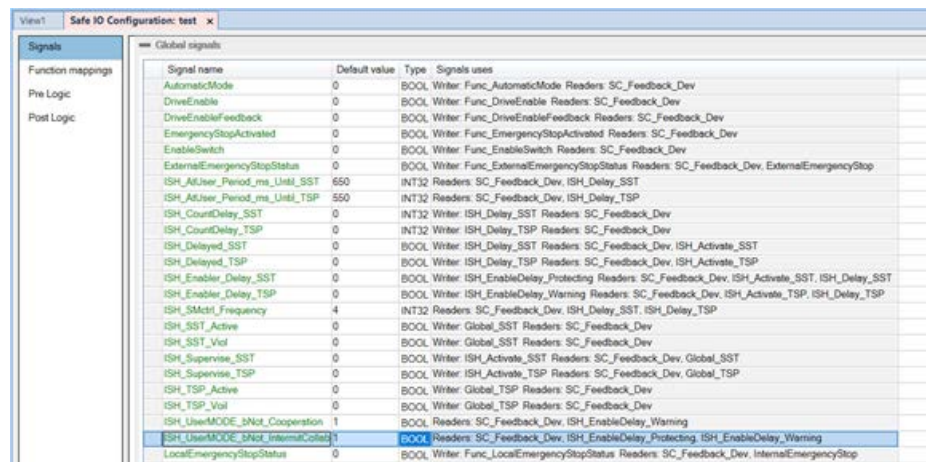

Signal name	Default value	Type	Signals uses
AutomaticMode	0	BOOL	Writer: Func_AutomaticMode Readers: SC_Feedback_Dev
DriveEnable	0	BOOL	Writer: Func_DriveEnable Readers: SC_Feedback_Dev
DriveEnableFeedback	0	BOOL	Writer: Func_DriveEnableFeedback Readers: SC_Feedback_Dev
EmergencyStopActivated	0	BOOL	Writer: Func_EmergencyStopActivated Readers: SC_Feedback_Dev
EnableSwitch	0	BOOL	Writer: Func_EnableSwitch Readers: SC_Feedback_Dev
ExternalEmergencyStopStatus	0	BOOL	Writer: Func_ExternalEmergencyStopStatus Readers: SC_Feedback_Dev, ExternalEmergencyStop
ISH_AllUser_Period_ma_Until_SST	650	INT32	Readers: SC_Feedback_Dev, ISH_Delay_SST
ISH_AllUser_Period_ma_Until_TSP	550	INT32	Readers: SC_Feedback_Dev, ISH_Delay_TSP
ISH_CountDelay_SST	0	INT32	Writer: ISH_Delay_SST Readers: SC_Feedback_Dev
ISH_CountDelay_TSP	0	INT32	Writer: ISH_Delay_TSP Readers: SC_Feedback_Dev
ISH_Delayed_SST	0	BOOL	Writer: ISH_Delay_SST Readers: SC_Feedback_Dev, ISH_Activate_SST
ISH_Delayed_TSP	0	BOOL	Writer: ISH_Delay_TSP Readers: SC_Feedback_Dev, ISH_Activate_TSP
ISH_Enabler_Delay_SST	0	BOOL	Writer: ISH_EnableDelay_Protecting Readers: SC_Feedback_Dev, ISH_Activate_SST, ISH_Delay_SST
ISH_Enabler_Delay_TSP	0	BOOL	Writer: ISH_EnableDelay_Warning Readers: SC_Feedback_Dev, ISH_Activate_TSP, ISH_Delay_TSP
ISH_SModF_Frequency	4	INT32	Readers: SC_Feedback_Dev, ISH_Delay_SST, ISH_Delay_TSP
ISH_SST_Active	0	BOOL	Writer: Global_SST Readers: SC_Feedback_Dev
ISH_SST_Viol	0	BOOL	Writer: Global_SST Readers: SC_Feedback_Dev
ISH_Supervise_SST	0	BOOL	Writer: ISH_Activate_SST Readers: SC_Feedback_Dev, Global_SST
ISH_Supervise_TSP	0	BOOL	Writer: ISH_Activate_TSP Readers: SC_Feedback_Dev, Global_TSP
ISH_TSP_Active	0	BOOL	Writer: Global_TSP Readers: SC_Feedback_Dev
ISH_TSP_Viol	0	BOOL	Writer: Global_TSP Readers: SC_Feedback_Dev
ISH_UserMODE_bNot_IntemitCollab	1	BOOL	Readers: SC_Feedback_Dev, ISH_EnableDelay_Protecting, ISH_EnableDelay_Warning
LocalEmergencyStopStatus	0	BOOL	Writer: Func_LocalEmergencyStopStatus Readers: SC_Feedback_Dev, InternalEmergencyStop

xx220000436

- 6 Apply the configuration to the controller by clicking **Write to Controller** in the **Controller** group in the **Configuration** category.

If the SpeedHandling function requires to be reactivated after deactivation, make sure:

- the signal **ISH_UserMODE_bNot_IntemitCollab** in SafeMove configuration is set to 0, and,
- the function **ISH_b_FunctionalityIsUsed** in RAPID program is set to TRUE.

Changing the speed limit when WarningArea is triggered

When users enter the warning area, the robot speed is limited to 250 mm/sec by default. Use the following procedure to change the speed limit based on risk assessment of the final application:

- 1 In RobotStudio, open the RAPID program **InternalSpeedHandling_User** in task **T_ROB1**.

Continues on next page

- 2 Navigate to the function `ISH_n_Speed_In_WarningArea_mm_s` and set its value from default 250 to any required value.

```
T_ROB1/InternalSpeedHandling_User* x |
52 ! -> AtUser_MODE_IsNot_IntermitCollab
53 ! -> AtUser_Period_ms_Until_SST
54 ! -> AtUser_Period_ms_Until_TSP
55
56 ! DEFAULT is 250 mm/s, change according to the TSP max velocity set in SafeMove Configuration
57 TASK_PERS num ISH_n_Speed_In_WarningArea_mm_s := 200;
```

xx2200000437

- 3 Save the change and apply to the controller.

The speed limit can also be changed in SafeMove configurations using the following procedure:

- 1 Open the RobotStudio.
- 2 Log in the controller using the Admin account and request the write access.
- 3 In the **Controller** tab, choose **Visual SafeMove** from the **Safety** group in the **Configuration** category.
- 4 In the left pane of the window, choose **Global_TSP** under the **Tool Speed Supervisions** from the navigation tree.



xx2200000438

3 Installation and commissioning

3.6.8 Use cases of safety configurations

Continued

- 5 In the **Visual SafeMove Properties** window, set the **Max speed (mm/s)** in the **Speed limits** area to a required value.



xx220000439

- 6 Apply the configuration to the controller by clicking **Write to Controller** in the **Controller** group in the **Configuration** category.

Changing the execution delay time in template SafeMove configuration file

Configurations of SST and TSP are predefined in the template SafeMove configuration file as two global signals `ISH_AtUser_Period_ms_Until_SST` and `ISH_AtUser_Period_ms_Until_TSP`.

- `ISH_AtUser_Period_ms_Until_SST`: default value is 650 ms. If a period of 650 ms elapses after `ProtectingArea` is triggered but the robot still moves, the SST will be triggered to stop robot movement immediately.
- `ISH_AtUser_Period_ms_Until_TSP`: default value is 550 ms. If a period of 550 ms elapses after `WarningArea` is triggered but the robot still moves in a speed larger than the defined speed limit value, the TSP will be triggered to stop robot movement immediately.

It is possible to change the values of `ISH_AtUser_Period_ms_Until_SST` and `ISH_AtUser_Period_ms_Until_TSP` according to application requirements using the following procedure. The change must be based on the risk assessment of the final application.

- 1 Open the RobotStudio.
- 2 Log in the controller using the Admin account and request the write access.

Continues on next page

- 3 In the **Controller** tab, choose **Visual SafeMove** from the **Safety** group in the **Configuration** category.
- 4 In the **Visual SafeMove** tab, click **Safe IO Configurator** in the **Configuration** group.
- 5 In the displayed **Safe IO Configuration** window, go to the signals **ISH_AtUser_Period_ms_Until_SST** and **ISH_AtUser_Period_ms_Until_TSP** in the global signal list and reset the value as required.

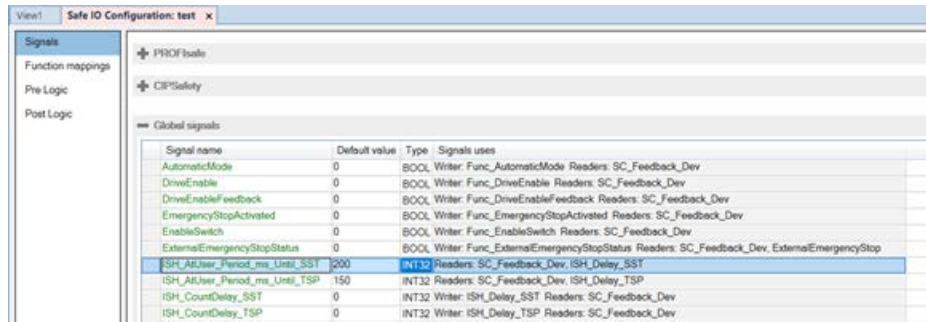

Signal name	Default value	Type	Signals uses
AutomaticMode	0	BOOL	Writer: Func_AutomaticMode Readers: SC_Feedback_Dev
DriveEnable	0	BOOL	Writer: Func_DriveEnable Readers: SC_Feedback_Dev
DriveEnableFeedback	0	BOOL	Writer: Func_DriveEnableFeedback Readers: SC_Feedback_Dev
EmergencyStopActivated	0	BOOL	Writer: Func_EmergencyStopActivated Readers: SC_Feedback_Dev
EnableSwitch	0	BOOL	Writer: Func_EnableSwitch Readers: SC_Feedback_Dev
ExternalEmergencyStopStatus	0	BOOL	Writer: Func_ExternalEmergencyStopStatus Readers: SC_Feedback_Dev, ExternalEmergencyStop
ISH_AtUser_Period_ms_Until_SST	200	INT32	Readers: SC_Feedback_Dev, ISH_Delay_SST
ISH_AtUser_Period_ms_Until_TSP	150	INT32	Readers: SC_Feedback_Dev, ISH_Delay_TSP
ISH_CountDelay_SST	0	INT32	Writer: ISH_Delay_SST Readers: SC_Feedback_Dev
ISH_CountDelay_TSP	0	INT32	Writer: ISH_Delay_TSP Readers: SC_Feedback_Dev

xx220000440

- 6 Apply the configuration to the controller by clicking **Write to Controller** in the **Controller** group in the **Configuration** category.

This page is intentionally left blank

4 Maintenance

4.1 Introduction

Structure of this chapter

This chapter describes all the maintenance activities recommended for the CRB 15000.

It is based on the maintenance schedule found at the beginning of the chapter. The schedule contains information about required maintenance activities including intervals, and refers to procedures for the activities.

Each procedure contains all the information required to perform the activity, including required tools and materials.

The procedures are gathered in different sections and divided according to the maintenance activity.

Safety information

Observe all safety information before conducting any service work.

There are general safety aspects that must be read through, as well as more specific safety information that describes the danger and safety risks when performing the procedures. Read the chapter [Safety on page 17](#) before performing any service work.

The maintenance must be done by qualified personnel in accordance with the safety requirements set forth in the applicable national and regional standards and regulations.



Note

If the CRB 15000 is connected to power, always make sure that the CRB 15000 is connected to protective earth and a residual current device (RCD) before starting any maintenance work.

For more information see:

- *Product manual - OmniCore C30*
- [Robot cabling and connection points on page 99.](#)

4 Maintenance

4.2.1 Specification of maintenance intervals

4.2 Maintenance schedule and expected component life

4.2.1 Specification of maintenance intervals

Introduction

The intervals are specified in different ways depending on the type of maintenance activity to be carried out and the working conditions of the CRB 15000:

- Calendar time: specified in months regardless of whether the system is running or not.
- Operating time: specified in operating hours. More frequent running means more frequent maintenance activities.
- SIS: specified by the robot's SIS (Service Information System). A typical value is given for a typical work cycle, but the value will differ depending on how hard each part is run.

The SIS used in OmniCore is further described in the *Operating manual - OmniCore*.

Robots with the functionality *Service Information System* activated can show active counters in the device browser in RobotStudio, or on the FlexPendant.

4.2.2 Maintenance schedule

Scheduled and non-predictable maintenance

The robot must be maintained regularly to ensure proper function. The maintenance activities and intervals are specified in the table below.

Non-predictable situations also give rise to inspections of the robot. Any damage must be attended to immediately.

Life of each component

The inspection intervals *do not* specify the life of each component.

Maintenance schedule

Maintenance activities	Regularly	Every 6 months	Every 12 months	Reference
Cleaning the robot	x			Cleaning the CRB 15000 on page 195
Inspecting the robot	x			Inspecting the robot on page 186
Inspecting the robot harness		x ⁱ		Inspecting the cable harness on page 190
Testing the brake release functionality		x		Testing the brake release functionality on page 196
Testing the brake release tool		x		Testing the brake release functionality on page 196
Running the <i>Cyclic Brake Check</i> routine ⁱⁱ	x			Running the Cyclic Brake Check routine on page 198 Application manual - Functional safety and SafeMove
Testing the functionality of the joint electronics		x		Testing the functionality of the joint electronics on page 199

ⁱ Replace if damage or cracks are detected.

ⁱⁱ Not needed separately if already included in the application.
Recommended test interval is within the range 8-48 hours.

4 Maintenance

4.3.1 Inspecting the robot

4.3 Inspection activities

4.3.1 Inspecting the robot

Required equipment

Equipment, etc.	Article number	Note
Standard toolkit	-	Content is defined in section Standard toolkit on page 1099 .

Inspecting the robot

Use these procedures to inspect the robot.

Inspecting the light indicators of the manipulator

	Action	Note
1	Turn on the power supply on the controller.	
2	Check the lights of the arm-side interface. If the lights do not work as configured, contact your local ABB office.	A description of the LED output indicators is found in Arm-side interface on page 105 .

Checking the overall condition of the manipulator

	Action	Note
1	Look for abnormal wear or contamination.	Clean as necessary. See Cleaning the CRB 15000 on page 195 .
2	Check for loose hardware at robot arms, base (foundation screws), and tool flange.	Tighten loose hardware at base (foundation screws tightening torque: 32 Nm \pm 10%) and tool flange, if any.
3	Check for seepage of lubricants.	If any seepage is found, contact ABB.

Inspecting the covers

	Action	Note
1	Visually inspect all outer covers for damage. If any cover is damaged or cannot perform its protective function for other reasons, it must be replaced.	Spare part numbers are found in <i>Product manual, spare parts - CRB 15000</i> .
2	Make sure that all covers are fully fastened. Manually check that the parts are not loose. Tighten, if needed.	Tightening torques specified in Tightening torques to be inspected on page 187 .

Inspecting the floor cable

The floor cable comprises the cabling between the robot and the controller cabinet.

	Action	Note
1	Make an overall visual inspection of the cable in order to detect wear or damage.	Replace the cable if wear, cracks or damage is detected. See article numbers in Robot cabling and connection points on page 99 .

Continues on next page

Checking the presence of the brake release tool



Note

This inspection is only needed for robots using the external brake release tool, see [Installation of brake release tool on page 75](#).

	Action	Note
1	Check that the brake release tool is available at its storage location close to the robot.	Brake release tool: 3HAC079146-001. See Installation of brake release tool on page 75 .

Tightening torques to be inspected

Tightening torques, CRB 15000-5/0.95

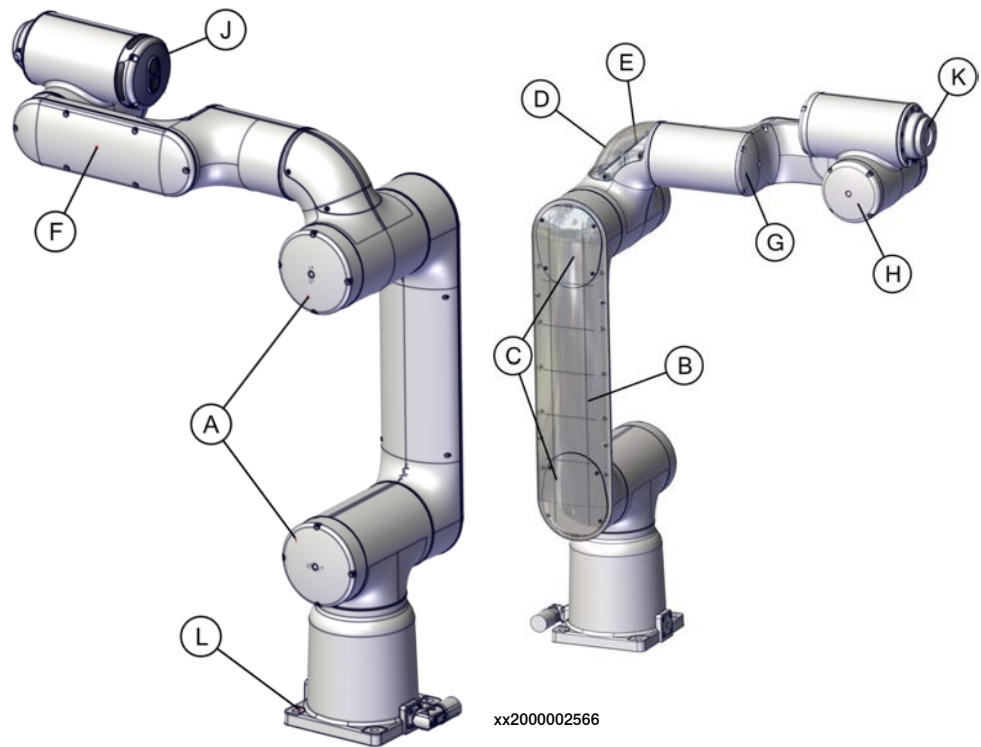

xx2000002565

Position	Cover	Screws	Tightening torque
A	Cover for axis 2/3	Hex socket head cap screw M3x30 12.9 Lafre 2C2B/FC6.9	0.45 Nm
B	Lower arm cover	Hex socket head cap screw M3x16 12.9 Lafre 2C2B/FC6.9	0.45 Nm
C	Lower arm inner cover	Hex socket head cap screw M3x8 12.9 Lafre 2C2B/FC6.9	1.4 Nm
D	Housing top cover	Hex socket head cap screw M3x8 12.9 Lafre 2C2B/FC6.9	0.45 Nm

Continues on next page

4 Maintenance

4.3.1 Inspecting the robot

Continued

Position	Cover	Screws	Tightening torque
E	Housing inner plate	Hex socket head cap screw M3x8 12.9 Lafre 2C2B/FC6.9	1.4 Nm
F	Tubular cover	Flange socket head screw with glue 3HAB3413-312 M3x12 12.9 Lafre 2C2B/FC6.9+PrO-COat111, with NYPLAS glue For tubular cover of CRB 15000-5/0.95. Always use new screws. If ordering a new axis-4 or axis- 5 joint unit spare part, new screws for the tubular cover are included.	1.6 Nm
G	Axis-4 cover	Hex socket head cap screw M3x8 12.9 Lafre 2C2B/FC6.9	0.2 Nm
H	Axis-5 cover	Hex socket head cap screw M3x8 12.9 Lafre 2C2B/FC6.9	0.2 Nm
J	Arm side interface	Hex socket head cap screw M3x12 12.9 Lafre 2C2B/FC6.9	0.45 Nm
K	Tool flange	Hex socket head cap screw M3x12 12.9 Lafre 2C2B/FC6.9	0.45 Nm
L	Base	M10x35 8.8	32 Nm \pm 10%

Tightening torques, CRB 15000-10/1.52 and CRB 15000-12/1.27

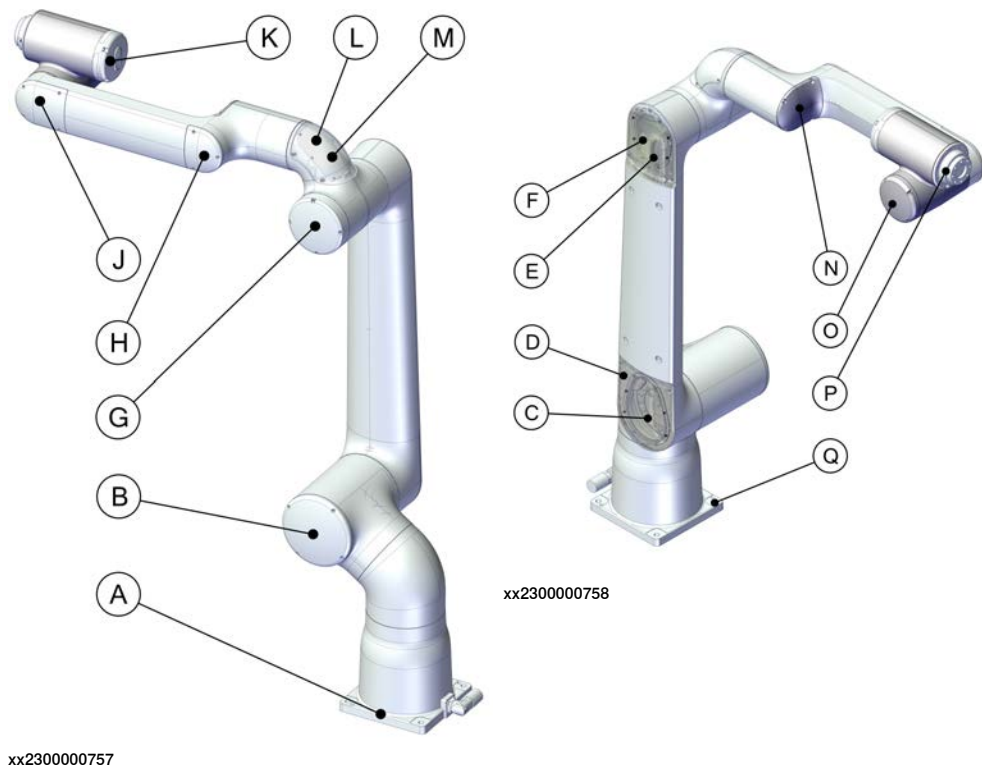

Continues on next page

Position	Cover	Screws	Tightening torque
A	Base cover	Hex socket head cap screw M3x8 12.9 Lafre 2C2B/FC6.9	1.4 Nm
B	Swing cover	Hex socket head cap screw M3x12 12.9 Lafre 2C2B/FC6.9	1.4 Nm
C	Lower arm cover, lower	Hex socket head cap screw M3x12 12.9 Lafre 2C2B/FC6.9	1.4 Nm
D	Lower arm, inner cover, lower	Hex socket head cap screw M3x12 12.9 Lafre 2C2B/FC6.9	1.4 Nm
E	Lower arm cover, upper	Hex socket head cap screw M3x8 12.9 Lafre 2C2B/FC6.9	1.4 Nm
F	Lower arm, inner cover, upper	Hex socket head cap screw M3x8 12.9 Lafre 2C2B/FC6.9	1.4 Nm
G	Housing side cover	Hex socket head cap screw M3x30 12.9 Lafre 2C2B/FC6.9	1.4 Nm
H	Tubular cover, lower	Hex socket head cap screw M3x12 12.9 Lafre 2C2B/FC6.9	1.4 Nm
J	Tubular cover, upper	Hex socket head cap screw M3x12 12.9 Lafre 2C2B/FC6.9	1.4 Nm
K	Arm side interface	Hex socket head cap screw M3x20 12.9 Lafre 2C2B/FC6.9	0.45 Nm
L	Housing cover	Hex socket head cap screw M3x8 12.9 Lafre 2C2B/FC6.9	0.45 Nm
M	Housing inner cover	Hex socket head cap screw M3x8 12.9 Lafre 2C2B/FC6.9	1.4 Nm
N	Axis-4 cover	Hex socket head cap screw M3x8 12.9 Lafre 2C2B/FC6.9	0.9 Nm
O	Axis-5 cover	Hex socket head cap screw M3x12 12.9 Lafre 2C2B/FC6.9	1.4 Nm
P	Axis-6 flange	Hex socket head cap screw M3x12 12.9 Lafre 2C2B/FC6.9	1.9 Nm
Q	Base	M10x35 8.8	32 Nm \pm 10%

4 Maintenance

4.3.2 Inspecting the cable harness

4.3.2 Inspecting the cable harness

Location of cable harness

Cable harness, CRB 15000-5/0.95

The figures show the location for the cable harness of CRB 15000-5/0.95.

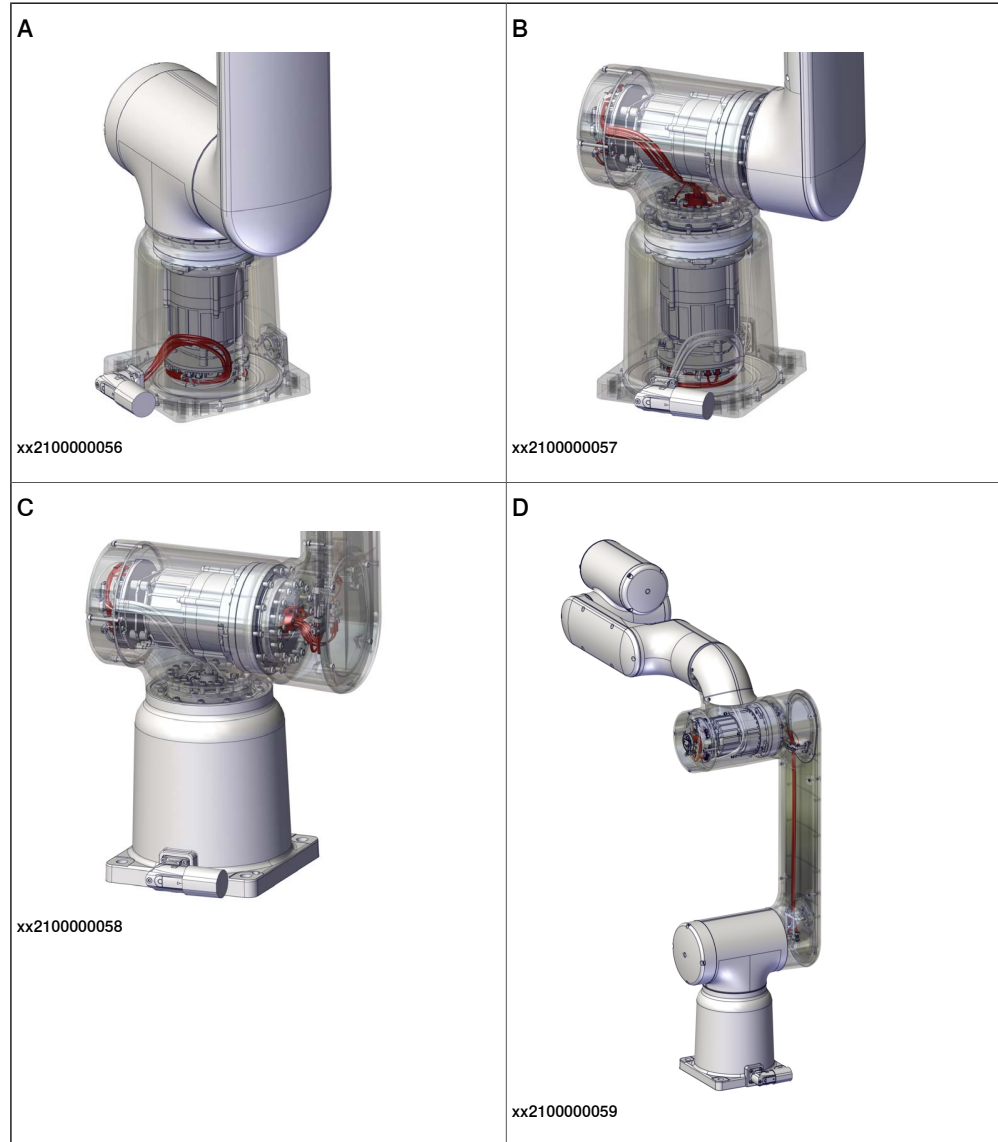

	Spare part	Spare part number
A	Cable harness, base socket	3HAC083725-001
B	Cable harness, joint 1	3HAC073204-001
C	Cable harness, joint 2	3HAC073205-001
D	Cable harness, joint 3	3HAC073207-001

Continues on next page

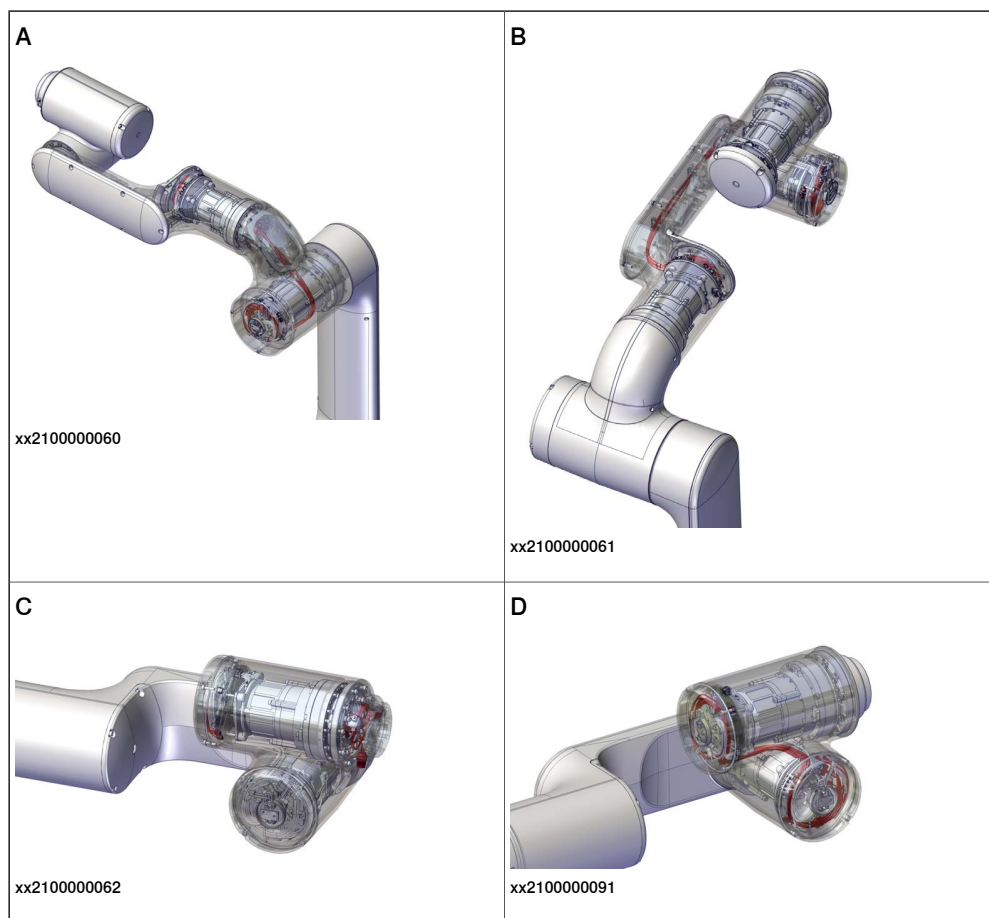

	Spare part	Spare part number
A	Cable harness, joint 4	3HAC073206-001
B	Cable harness, joint 5	3HAC073206-001
C	Cable harness, joint 6	3HAC073208-001
D	Cable harness, transition joint-5 and joint-6	3HAC083726-001

4 Maintenance

4.3.2 Inspecting the cable harness

Continued

Cable harness, CRB 15000-10/1.52 and CRB 15000-12/1.27

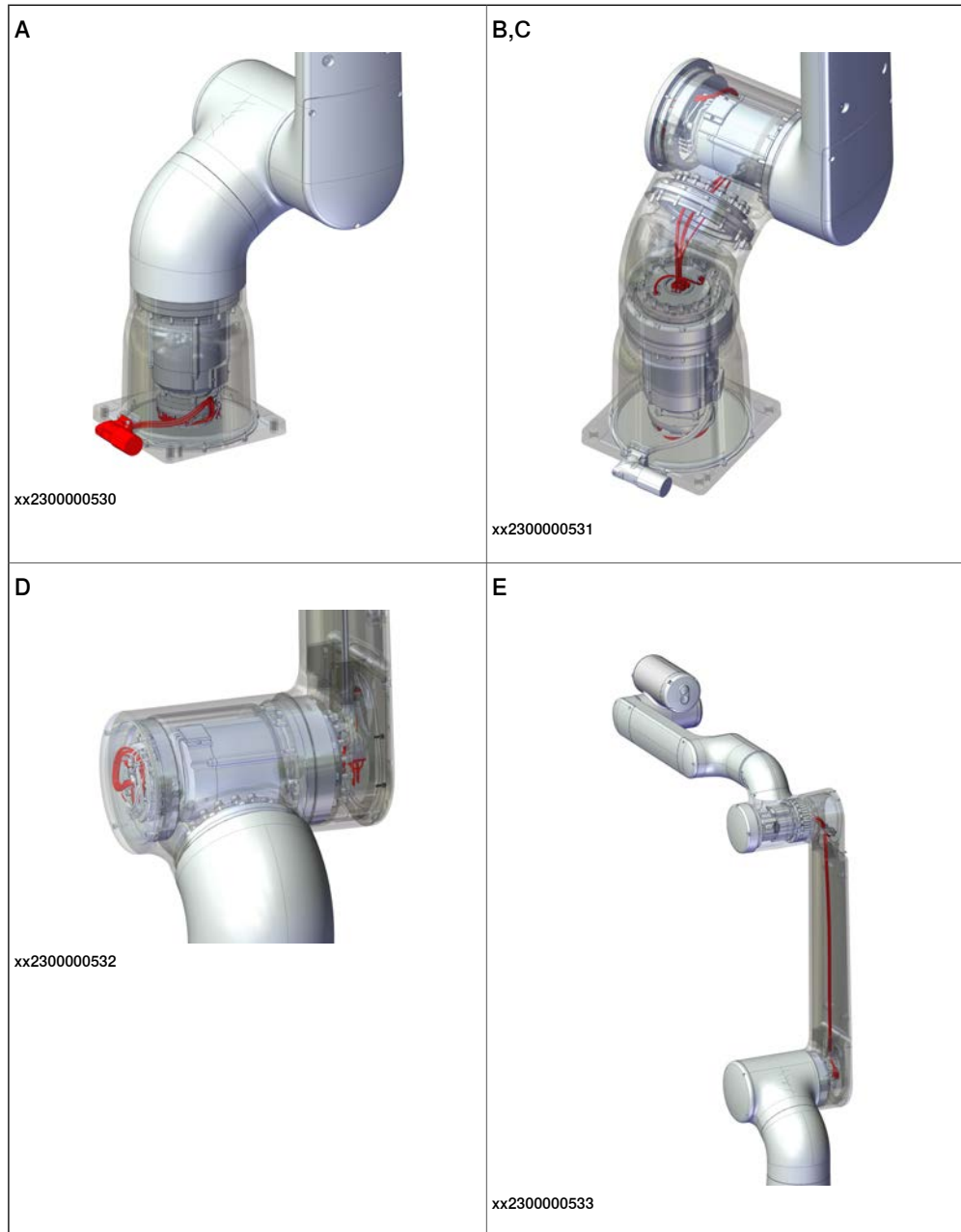

	Spare part	Spare part number
A	Cable harness, base socket	3HAC083725-001
B	Cable harness, joint 1 (CRB 15000-10/1.52)	3HAC083661-001
C	Cable harness, joint 1 (CRB 15000-12/1.27)	3HAC080959-001
D	Cable harness, joint 2	3HAC080960-001
E	Cable harness, joint 3	3HAC080965-001

Continues on next page

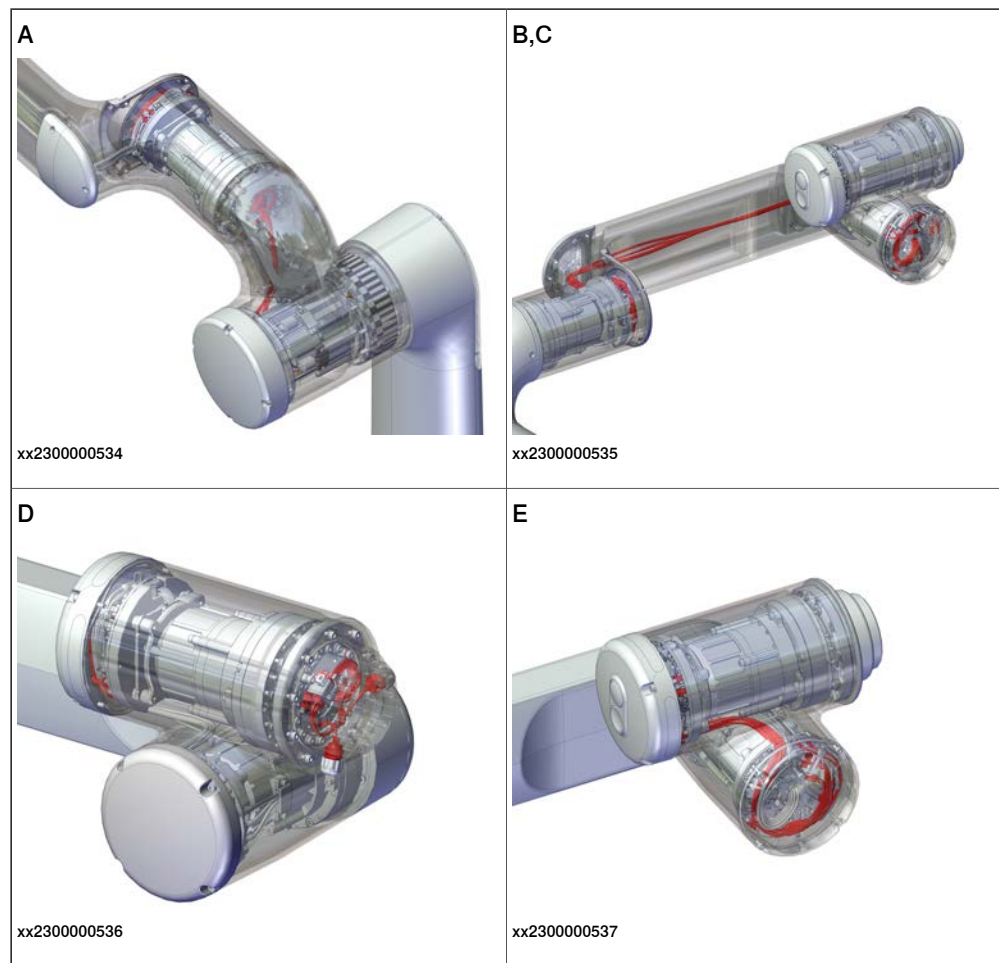

	Spare part	Spare part number
A	Cable harness, joint 4	3HAC080961-001
B	Cable harness, joint 5 (CRB 15000-10/1.52)	3HAC083669-001
C	Cable harness, joint 5 (CRB 15000-12/1.27)	3HAC083668-001
D	Cable harness, joint 6	3HAC073208-001
E	Cable harness, transition joint-5 and joint-6	3HAC083726-001

Required equipment

Equipment, etc.	Article number	Note
Standard toolkit	-	Content is defined in section Standard toolkit on page 1099 .



Continues on next page

4 Maintenance

4.3.2 Inspecting the cable harness

Continued

Inspecting the cable harness

	Action	Note
1	 CAUTION Turn off all supplies for electrical power to the robot, before starting the repair work.	
2	 ELECTROSTATIC DISCHARGE (ESD) The unit is sensitive to ESD. Before handling the unit read the safety information in section The unit is sensitive to ESD on page 53 .	
3	Remove all covers required to achieve visibility of all cabling.	
4	Visually inspect all arm cabling. Look for abrasions, cuts or crush damages. If any damage is detected, replace the cabling.	
5	Refit all covers. If any cover is damaged, it must be replaced.  CAUTION Be careful not to squeeze any cabling during the refitting procedure.	Replacement information for the covers, such as part numbers and tightening torques for the attachment screws are detailed in section Tightening torques to be inspected on page 187 .

4.4 Cleaning activities

4.4.1 Cleaning the CRB 15000

General

Different cleaning methods are allowed depending on the type of protection of the CRB 15000.



Note

Always verify the protection type of the robot before cleaning.



WARNING

Turn off all electrical power supplies to the robot before starting the cleaning.

Special cleaning considerations

This section specifies some special considerations when cleaning the robot.

- Always use cleaning equipment as specified. Any other cleaning equipment may shorten the life of the robot.
- Always check that all protective covers are fitted to the robot before cleaning.
- Do not use compressed air to clean the robot.
- Do not use solvents that are not approved by ABB to clean the robot.
- Do not remove any covers or other protective devices before cleaning the robot.

Cleaning methods

The following table defines what cleaning methods are allowed for ABB manipulators depending on the protection type.

Protection type	Cleaning method			
	Vacuum cleaner	Wipe with cloth	Rinse with water	High pressure water, steam or spray
Standard	Yes	Yes. With light cleaning detergent.	No	No

Usable detergents

This table specifies approved light cleaning detergents according to methods in the table [Cleaning methods on page 195](#).

Detergent ⁱ	Concentration
Isopropyl Alcohol	70%
Ethanol	75%, 99.7%

ⁱ The manipulator can be cleaned (wiped with cloth) occasionally with specified detergents. Long term use may lead to surface/appearance deterioration.

4 Maintenance

4.5.1 Testing the brake release functionality

4.5 Testing activities

4.5.1 Testing the brake release functionality

When to test the brake release functionality

Test the brake release functionality regularly as a maintenance activity.

The brake release functionality shall be tested after heavy collisions. This does not apply to collisions which may routinely be experienced as part of a power and force limiting application.



CAUTION

Depending on what RobotWare version is installed, the brake release functionality differs. On robot with RobotWare 7.10 or later, the brakes are released from the FlexPendant, see [Testing the brake release functionality from the FlexPendant on page 196](#). On robots with RobotWare earlier than 7.10, the brakes are released using an external brake release tool, see [Testing the brake release functionality with external tool on page 196](#).



CAUTION

At least two persons should be present when releasing the brakes.

Testing the brake release functionality from the FlexPendant

	Action	Note
1	Test the brake release functionality on each axis, by using the FlexPendant.	See Manually releasing the brakes on page 69 .
2	If the holding brake does not release, check following: <ul style="list-style-type: none">• Check for event log messages on the FlexPendant.	All event logs can be seen on the FlexPendant, or in <i>Technical reference manual - Event logs for RobotWare 7</i> .

Testing the brake release functionality with external tool

Required equipment

Equipment	Article number	Note
Brake release tool	3HAC079146-001	For releasing the holding brakes of a joint unit motor if the RobotWare version is 7.8 or older.  Note The spare parts related to the brake release function using the external tool are discontinued from Q2 2023.

Continues on next page

	Action	Note
1	Test the brake release functionality on each axis, by using the brake release tool.	See Manually releasing the brakes on page 69 .
2	If the holding brake does not release, check following: <ul style="list-style-type: none"> • Check for event log messages on the FlexPendant. • Look for damage to the magnet. Replace the tool if damaged. • See troubleshooting section Brake release tool does not work on page 1075. 	For OmniCore, all event logs from the software can be seen on the FlexPendant, or in <i>Technical reference manual - Event logs for RobotWare 7</i> .

4 Maintenance

4.5.2 Running the Cyclic Brake Check routine

4.5.2 Running the Cyclic Brake Check routine

When to run the Cyclic Brake Check routine

The Cyclic Brake Check routine shall be run in the application every 8-48 hours.
For set-up, see *Application manual - Functional safety and SafeMove*.

For advanced users

If it is not possible to run the Cyclic Brake Check routine regularly in the application, then:

- The holding brake safety is reduced to the equivalent of *PL c*.
- Use of such a configuration must be justified by risk assessment.
- The method described in [Brake testing on page 35](#) can be used to check that the brakes still function correctly.

4.5.3 Testing the functionality of the joint electronics

When to test the joint electronics

Test the functionality regularly as a maintenance activity.

Required equipment

No special equipment is required.

Testing the joint electronics

	Action	Note
1	Turn off power to the controller and then turn the power on again.	
2	Verify that the robot starts as expected.	

This page is intentionally left blank

5 Repair

5.1 Introduction

Structure of this chapter

This chapter describes repair activities for the CRB 15000. Each procedure contains the information required to perform the activity, for example spare parts numbers, required special tools, and materials.



WARNING

Repair activities not described in this chapter must only be carried out by ABB. Individual subcomponents shall not be exchanged.



Note

Unless otherwise specified, the repair activities are available for all the robot variants, but only the CRB 15000-5/0.95 is illustrated.

Report replaced units



Note

When replacing a part on the CRB 15000, report to your local ABB the serial number, the article number, and the revision of both the replaced unit and the replacement unit.

This is particularly important for safety equipment to maintain the safety integrity of the installation.

Safety information

Make sure to read through the chapter [Safety on page 17](#) before commencing any service work.



Note

If the CRB 15000 is connected to power, always make sure that the CRB 15000 is connected to protective earth and a residual current device (RCD) before starting any repair work.

For more information see:

- *Product manual - OmniCore C30*

5 Repair

5.2.1 Mounting instructions for sealings

5.2 General procedures

5.2.1 Mounting instructions for sealings

General

This section describes how to mount different types of sealings.

Equipment

Consumable	Article number	Note
Grease	3HAC042536-001	Shell Gadus S2

Rotating sealings

The following procedures describe how to fit rotating sealings.



CAUTION

Please observe the following before commencing any assembly of sealings:

- Protect the sealing during transport and mounting, especially the main lip on radial sealings.
- Keep the sealing in its original wrappings or protect it well before actual mounting.
- The fitting of sealings and gears must be carried out on clean workbenches.
- Use a protective sleeve for the main lip during mounting, when sliding over threads, keyways or other sharp edges.

Radial sealings

A radial sealing consists of a flexible rubber lip bonded to a rigid metal case. Only one side of the sealing is static with a metal insert.

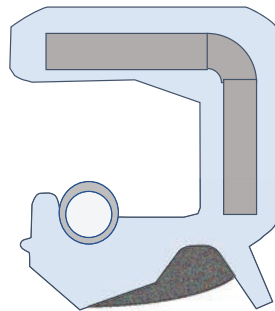

xx2300000433

	Action	Note
1	Check the sealing to ensure that: <ul style="list-style-type: none">• The sealing is of the correct type.• There is no damage on the main lip.	

Continues on next page

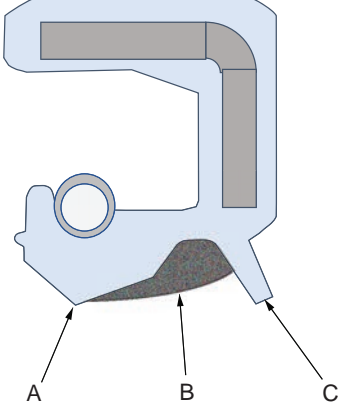
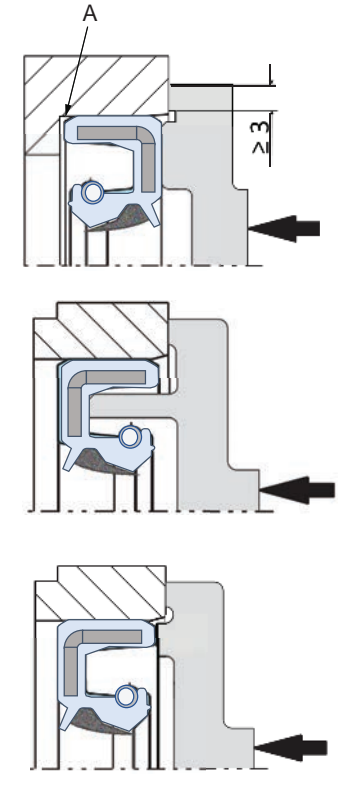
	Action	Note
2	Inspect the shaft surface before mounting. If scratches or damage are found, the shaft must be replaced since it may result in future leakage. Do not try to grind or polish the shaft surface to get rid of the defect.	
3	<p>Lubricate the sealing with grease just before fitting. (Not too early - there is a risk of dirt and foreign particles adhering to the sealing.)</p> <p>Fill 2/3 of the space between the dust lip and the main lip with grease. If the sealing is without dust lip, just lubricate the main lip with a thin layer of grease.</p>	<p>Article number is specified in Equipment on page 202.</p>  <p>xx200000071</p> <p>A Main lip B Grease C Dust lip</p>
4	Mount the sealing correctly with a mounting tool. Never hammer directly on the sealing as this may result in leakage.	 <p>xx200000072</p> <p>A Gap</p>

Continues on next page

5 Repair

5.2.1 Mounting instructions for sealings

Continued

Flange sealings and static sealings

The following procedure describes how to fit flange sealings and static sealings.

	Action
1	Check the flange surfaces. They must be even and free from pores. It is easy to check flatness using a gauge on the fastened joint (without sealing compound). If the flange surfaces are defective, the parts may not be used because leakage could occur.
2	Clean the surfaces properly in accordance with the recommendations of ABB.
3	Distribute the sealing compound evenly over the surface.
4	Tighten the screws evenly when fastening the flange joint.

O-rings

The following procedure describes how to fit o-rings.

	Action	Note
1	Ensure that the correct o-ring size is used.	
2	Check the o-ring for surface defects, burrs, shape accuracy, or deformation.	Defective o-rings, including damaged or deformed o-rings, may not be used.
3	Check the o-ring grooves and mating surfaces. They should be free of pores, contamination and obvious scratches/damage.	
4	Lubricate the o-ring with grease.	
5	Tighten the screws evenly while assembling.	
6	Check that the o-ring is not squashed outside the o-ring groove.	

5.3 Cable harness

5.3.1 Replacing the base cabling

Location of the cable harness

The cable harness is located as shown in the figure.

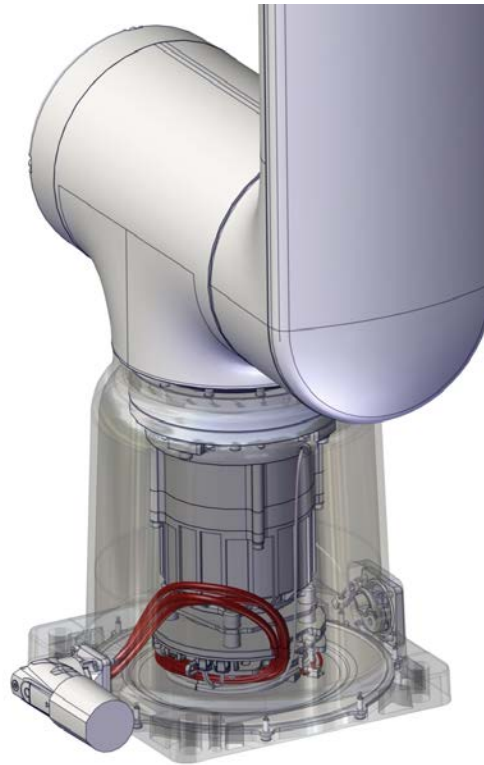

xx210000056

Summary of the replacement procedure

This is a brief summary of the replacement procedure, containing the major actions to be performed.

- 1 Jog the robot to transportation position.
- 2 Loosen the robot from the foundation and lay it down on its back.
 - For CRB 15000-5/0.95, this step requires two persons.
 - For CRB 15000-10/1.52 and CRB 15000-12/1.27, the robot requires to be lifted using lifting roundslings.
- 3 Remove the base cover.
- 4 Replace the cabling.

Continues on next page

5 Repair

5.3.1 Replacing the base cabling

Continued

Required spare parts



Note

The spare part numbers that are listed in the table can be out of date. See the latest spare parts of the CRB 15000 via myABB Business Portal, www.abb.com/myABB.

Spare part	Article number	Note
Cable harness, base socket	3HAC083725-001	

Required tools and equipment

Equipment	Article number	Note
Standard toolkit	-	Content is defined in section Standard toolkit on page 1099 .

Required consumables

Consumable	Article number	Note
Cable ties	-	
O-ring	3HAB3772-64	Base cover, used for CRB 15000-5/0.95.
Grease	3HAC042536-001	Shell Gadus S2

Removing the base cabling

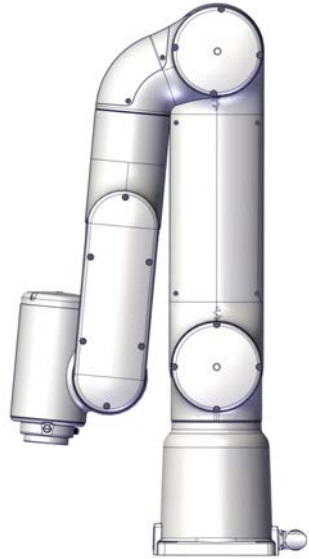

Use these procedures to remove the base cabling.

Preparations before removing the cabling

	Action	Note
1	Jog the robot to the specified position. Valid for CRB 15000-5/0.95 <ul style="list-style-type: none">• Axis 1: 0°• Axis 2: 0°• Axis 3: +85°• Axis 4: 0°• Axis 5: 0°• Axis 6: 0°	 xx2100000113

Continues on next page

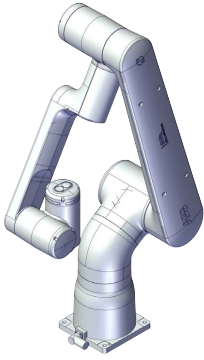
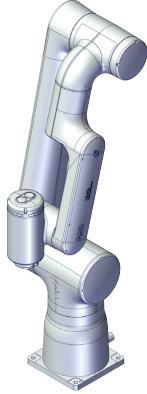
5.3.1 Replacing the base cabling
Continued

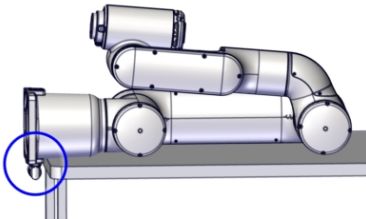
	Action	Note
	<p>Valid for CRB 15000-10/1.52</p> <ul style="list-style-type: none"> • Axis 1: 0° • Axis 2: -15° • Axis 3: -225° • Axis 4: 0° • Axis 5: -30° • Axis 6: 0° 	 <p>xx2300000380</p>
	<p>Valid for CRB 15000-12/1.27</p> <ul style="list-style-type: none"> • Axis 1: 0° • Axis 2: -10° • Axis 3: +85° • Axis 4: 0° • Axis 5: +15° • Axis 6: 0° 	 <p>xx2300000381</p>
2	<p> CAUTION</p> <p>Turn off all supplies for electrical power to the robot, before starting the repair work.</p>	
3	<p>Prepare a working bench where the robot can be laid down on its back with the base socket outside the table edge.</p>	 <p>xx2100000414</p>

Laying down the robot (-5/0.95)

	Action	Note
1	<p> CAUTION</p> <p>The CRB 15000 robot weighs 28 kg. A minimum of two persons are required for lifting as well as securing the robot in order to avoid any damage, instability, and injury.</p>	

Continues on next page

5 Repair

5.3.1 Replacing the base cabling

Continued

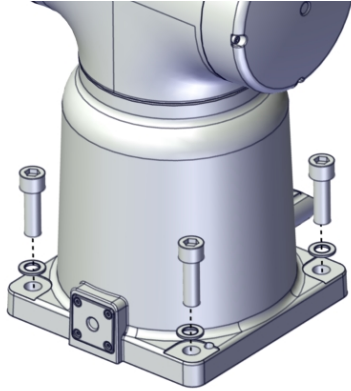
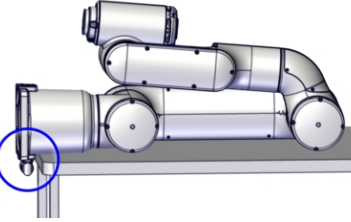

	Action	Note
2	<p>Loosen the robot from the foundation.</p> <ul style="list-style-type: none"> • Person 1: keep holding the robot stable. • Person 2: loosen the robot base from the foundation by removing the attachment screws and washers. • Both persons: grasp the robot at appropriate locations and lay it down on its back on a working bench. Do not damage the base socket. <p> CAUTION</p> <p>Do not leave the robot standing unfastened to the foundation, it is not stable on its own.</p>	 <p>xx2100000415</p>  <p>xx2100000414</p>

Laying down the robot (-10/1.52 and -12/1.27)

	Action	Note
1	<p> CAUTION</p> <p>The weight of the CRB 15000 robot is up to 51 kg All lifting accessories used must be sized accordingly.</p>	

Continues on next page

5.3.1 Replacing the base cabling
Continued



	Action	Note
2	<p>Attach the roundslings to the robot according to the figure. Make sure the roundslings do not rub against any sharp edges.</p>	<p>CRB 15000-10/1.52</p>  <p>xx2300000384</p> <p>CRB 15000-12/1.27</p>  <p>xx2300000385</p>
3	<p>Stretch the roundsling to take the weight of the robot.</p> <p> Note Do not stretch the roundsling too much.</p>	

Continues on next page

5 Repair

5.3.1 Replacing the base cabling

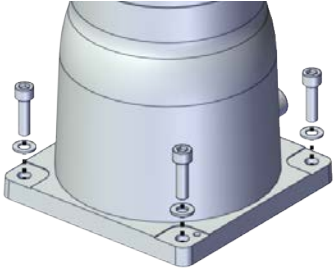
Continued

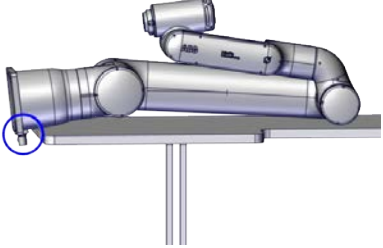
	Action	Note
4	Loosen the robot base from the foundation by removing the foundation attachment screws.	 <p>xx2300001060</p>
5	 WARNING Personnel must not, under any circumstances, be present under the suspended load.	
6	Lay the robot down on its back on a working bench. Do not damage the base socket.	 <p>xx2300001061</p>

Continues on next page

5.3.1 Replacing the base cabling
Continued

Removing the base cover

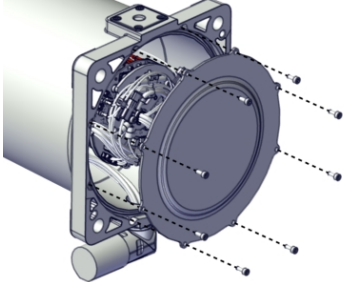
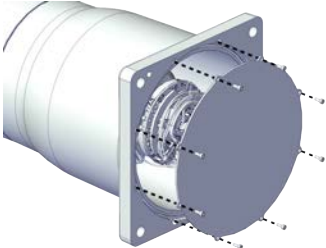
	Action	Note
1	Remove the bottom cover by removing the attachment screws.	<p>Valid for CRB 15000-5/0.95</p>  <p>xx2000002007</p> <p>Valid for CRB 15000-10/1.52 and CRB 15000-12/1.27</p>  <p>xx2300000760</p>

Disconnecting the base cabling

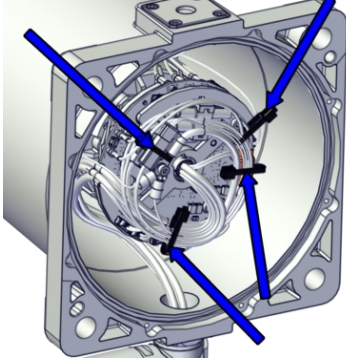
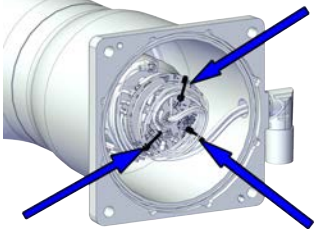
	Action	Note
1	Cut the cable ties.	<p>Valid for CRB 15000-5/0.95</p>  <p>xx2100000424</p> <p>Valid for CRB 15000-10/1.52 and CRB 15000-12/1.27</p>  <p>xx2300000761</p>

Continues on next page

5 Repair

5.3.1 Replacing the base cabling

Continued

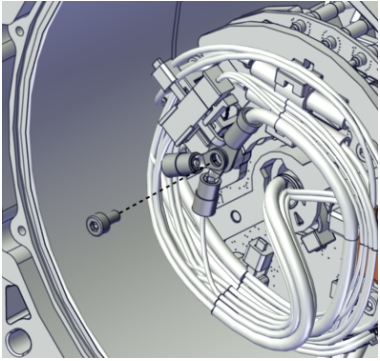
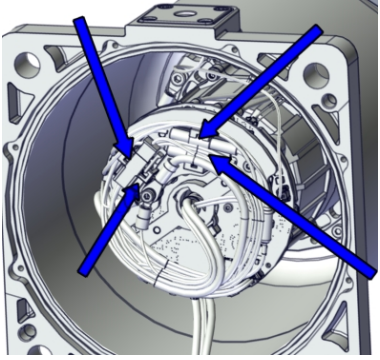
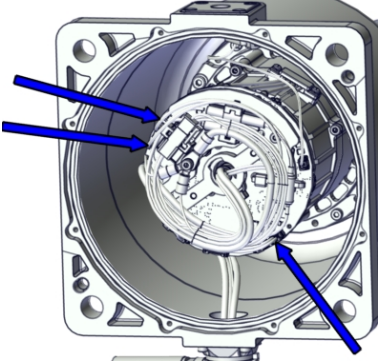
	Action	Note
2	Remove the functional and protective earth cables by removing the screw.	 <p>xx2100000425</p>
3	Snap loose and disconnect the connectors: <ul style="list-style-type: none"> • J1.DC+ • J1.DC- • J1.CS • J1.CP 	 <p>xx2100000426</p>
4	Disconnect the connectors from the drive board. <ul style="list-style-type: none"> • D1.X1 from X1 • D1.DC+ from DC+ • D1.DC- from ground 	 <p>xx2100000405</p>

Removing the base cabling

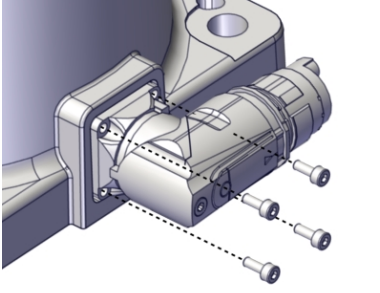
	Action	Note
1	Remove the attachment screws.	 <p>xx2100000406</p>

Continues on next page

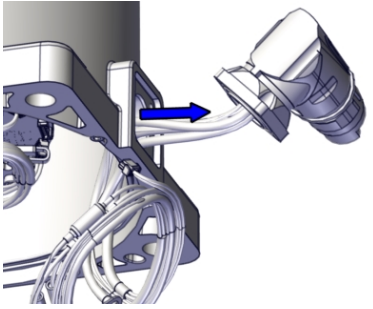
	Action	Note
2	Pull out the cabling from the base.	 <p>xx210000407</p>

Refitting the base cabling

Use these procedures to refit the base cabling.

Refitting the base cabling

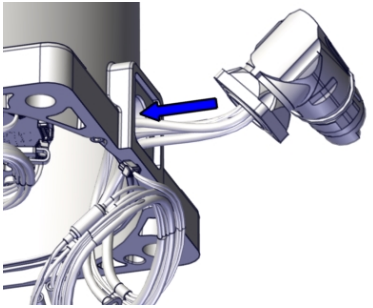
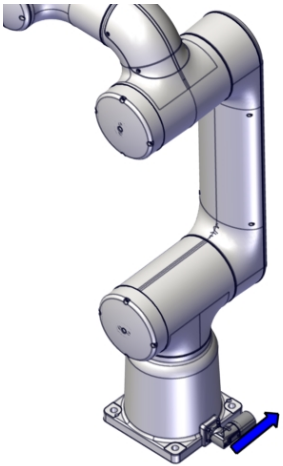
	Action	Note
1	Insert the cabling into the base.	 <p>xx210000408</p>
2	Orient the base connector so that it points to the right, seen from back of the robot.	 <p>xx210000409</p>

Continues on next page

5 Repair

5.3.1 Replacing the base cabling

Continued

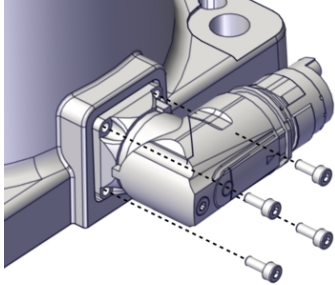
	Action	Note
3	Secure the base connector with the attachment screws.	<p>Hex socket head cap screw: M3x8 12.9 Lafre 2C2B/FC6.9 (4 pcs). Tightening torque: 0.8 Nm.</p>  <p>xx2100000406</p>

Connecting the base cabling

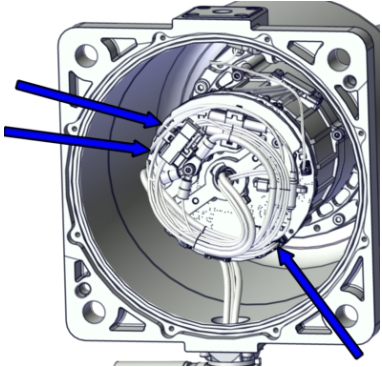
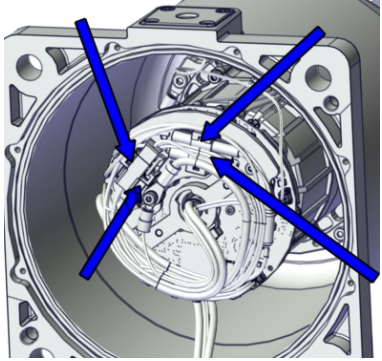
	Action	Note
1	 <p>ELECTROSTATIC DISCHARGE (ESD)</p> <p>The unit is sensitive to ESD. Before handling the unit read the safety information in section The unit is sensitive to ESD on page 53.</p>	
2	<p>Reconnect the connectors to the drive board.</p> <ul style="list-style-type: none"> • D1.X1 to X1 • D1.DC+ to DC+ • D1.DC- to Ground 	 <p>xx2100000405</p>
3	<p>Connect the connectors to each other and snap them to the cable holders.</p> <ul style="list-style-type: none"> • J1.DC+ to J1.DC+ • J1.DC- to J1.DC- • J1.CS to J1.CS • J1.CP to J1.CP 	 <p>xx2100000426</p>

Continues on next page

5.3.1 Replacing the base cabling
Continued

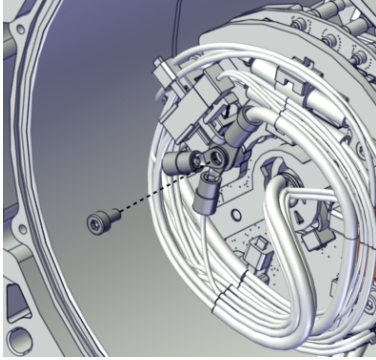
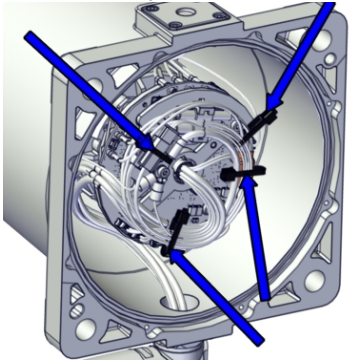
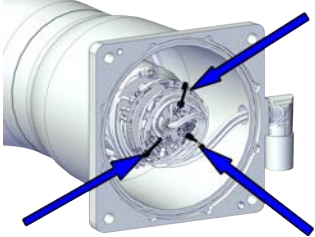
	Action	Note
4	Secure the cables for functional earth and protective earth with a screw.	<p>Hex socket head cap screw: M3x6 (1 pcs). Tightening torque: 0.8 Nm.</p>  <p>xx2100000425</p>
5	Secure the cabling with cable ties.	<p>Valid for CRB 15000-5/0.95 Cable ties (4 pcs)</p>  <p>xx2100000424</p> <p>Valid for CRB 15000-10/1.52 and CRB 15000-12/1.27 Cable ties (3 pcs)</p>  <p>xx2300000761</p>



Continues on next page

5 Repair

5.3.1 Replacing the base cabling

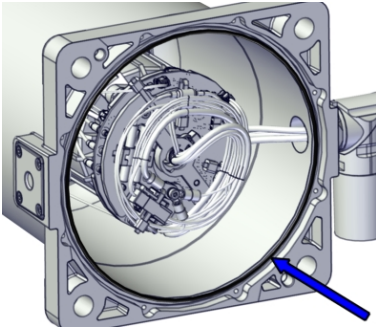

Continued

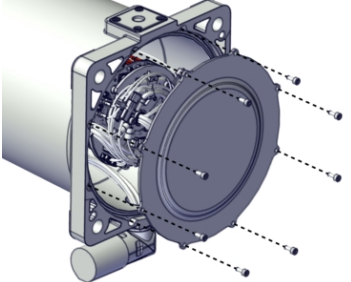
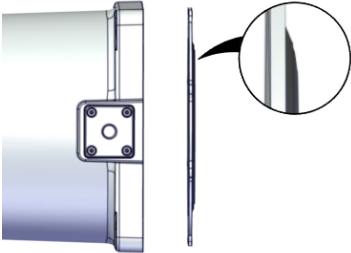
Refitting the base cover (-5/0.95)

	Action	Note
1	<p>Wipe, lubricate and fit the o-ring to its groove. Replace if damaged.</p>	<p>O-ring: 3HAB3772-64 Grease: 3HAC042536-001 (Shell Gadus S2)</p>  <p>xx2000002016</p>
2	<p>Refit the bottom cover with the attachment screws.</p> <p> Note</p> <p>For CRB 15000-5/0.95, fit the cover in correct direction, the protrusion of the cover must face outwards.</p>	<p>Hex socket head cap screw: M3x8 12.9 Lafre 2C2B/FC6.9 (8 pcs) Tightening torque: 1.2 Nm.</p>  <p>xx2000002007</p>  <p>xx2100000268</p>

Continues on next page

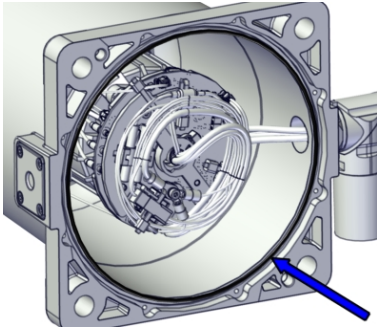
Refitting the base cover (-10/1.52 and -12/1.27)

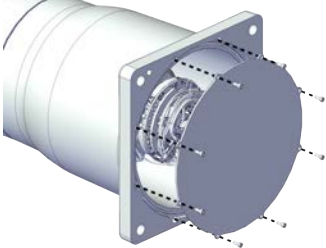
	Action	Note
1	Wipe, lubricate and fit the o-ring to its groove. Replace if damaged.	3HAC061327-072 Grease: 3HAC042536-001 (Shell Gadus S2)  xx2000002016
2	Refit the bottom cover with the attachment screws.  Note For CRB 15000-5/0.95, fit the cover in correct direction, the protrusion of the cover must face outwards.	Hex socket head cap screw: M3x8 12.9 Lafre 2C2B/FC6.9 (8 pcs) Tightening torque: 1.4 Nm.  xx2300000760

Lifting and securing the robot (-5/0.95)

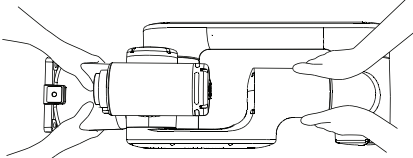
	Action	Note
1	 CAUTION The CRB 15000 robot weighs 28 kg. A minimum of two persons are required for lifting as well as securing the robot in order to avoid any damage, instability, and injury. Special consideration is necessary when mounting the robot in an elevated, suspended or wall mounted position.	
2	Grasp the robot at the foot and elbow, as shown in the figure, and lift it up from the transportation package.	 xx2100000118

Continues on next page



5 Repair

5.3.1 Replacing the base cabling



Continued

	Action	Note
3	<p>Carry the robot to the installation site.</p> <p> CAUTION</p> <p>Do not leave the robot standing unfastened to the foundation, it is not stable on its own.</p>	
4	<p>Fit two pins to the holes in the base.</p>	<p>Centering pins: DIN6325, hardened steel Ø6x24 mm, 2 pcs .</p>
5	<p>Raise the robot to standing and secure to foundation, paying attention to the centering holes at the bottom of the robot base.</p> <ul style="list-style-type: none">• Person 1: keep holding the robot stable.• Person 2: secure the robot base to the foundation with the securing screws and washers.	<p>Screws: M10x35, 4 pcs, quality 8.8 Washers: 23/10.5/2.5 mm Steel</p>
6	<p>Tighten the bolts in a crosswise pattern to ensure that the base is not distorted.</p>	<p>Tightening torque: 32 Nm ±10%</p>

Lifting and securing the robot (-10/1.52 and -12/1.27)

	Action	Note
1	<p>Make sure the robot is positioned in the recommended position for transportation and lifting.</p> <p> WARNING</p> <p>The robot is mechanically unstable if not secured to the foundation.</p>	<p>Recommended position for transportation and lifting is shown in Transportation and shipping position on page 57.</p>
2	<p> CAUTION</p> <p>The weight of the CRB 15000 robot is up to 51 kg All lifting accessories used must be sized accordingly.</p>	

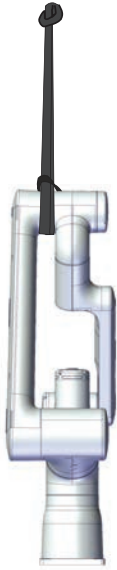
Continues on next page

	Action	Note
3	<p>Attach the roundslings to the robot according to the figure. Make sure the roundslings do not rub against any sharp edges.</p>	<p>CRB 15000-10/1.52</p>  <p>xx2300000384</p> <hr/> <p>CRB 15000-12/1.27</p>  <p>xx2300000385</p>
4	<p> WARNING Personnel must not, under any circumstances, be present under the suspended load.</p>	
5	<p>Raise the overhead crane to lift the robot.</p>	

Continues on next page

5 Repair

5.3.1 Replacing the base cabling

Continued

	Action	Note
6	Move the robot to the installation site.  CAUTION Do not leave the robot standing unfastened to the foundation, it is not stable on its own.	
7	Fit two pins to the holes in the base.	Centering pins: DIN6325, hardened steel Ø6x24 mm, 2 pcs .
8	Guide the robot gently, using the attachment screws while lowering it into its mounting position.	Make sure the robot base is correctly fitted onto the pins.
9	Fit the securing screws and washers in the attachment holes of the base.	Screws: M10x35, 4 pcs, quality 8.8 Washers: 23/10.5/2.5 mm Steel
10	Tighten the bolts in a crosswise pattern to ensure that the base is not distorted.	Tightening torque: 32 Nm ±10%

Concluding procedure

	Action	Note
1	 DANGER Make sure all safety requirements are met when performing the first test run. See Test run after installation, maintenance, or repair on page 90 .	

5.3.2 Replacing the axis-1 cabling

Location of the cable harness

The cable harness is located as shown in the figure.

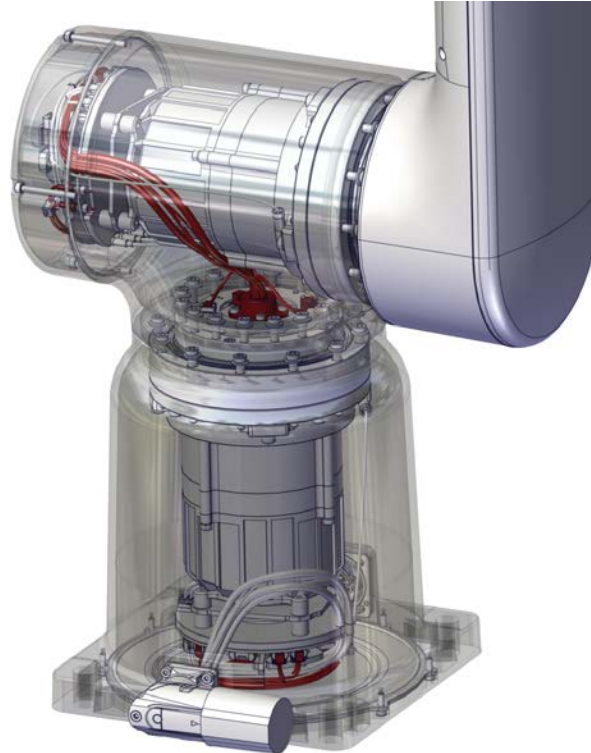

xx210000057

Summary of the replacement procedure

This is a brief summary of the replacement procedure, containing the major actions to be performed.

- 1 Separate the cabling between the swing and the lower arm.
- 2 Remove the lower and upper arm undivided.
- 3 Remove the axis-2 joint unit.
- 4 Remove the swing.
- 5 Loosen the base from the foundation and lay it down on its side.
- 6 Replace the cabling.

Required spare parts



Note

The spare part numbers that are listed in the table can be out of date. See the latest spare parts of the CRB 15000 via myABB Business Portal, www.abb.com/myABB.

Continues on next page

5 Repair

5.3.2 Replacing the axis-1 cabling

Continued

Spare part	Article number	Note
Cable harness, joint 1	3HAC073204-001	Used for CRB 15000-5/0.95. Also order new Cable tie: 3HAC075545-001.
Cable harness, joint 1 (CRB 15000-10/1.52)	3HAC083661-001	Used for CRB 15000-10/1.52. Also order new Cable tie: 3HAC075545-001.
Cable harness, joint 1 (CRB 15000-12/1.27)	3HAC080959-001	Used for CRB 15000-12/1.27. Also order new Cable tie: 3HAC075545-001.
Flange socket head screw with glue	3HAB3413-435	M4x35 12.9 Lafre 2C2B/FC6.9+PrO-COat111, with NYPLAS glue , 12 pcs Used for joint unit of CRB 15000-5/0.95. Always use new screws when re-fitting a joint unit. If ordering a new joint unit spare part, new screws are included.
Cable tie	3HAC075545-001	For securing joint unit cable.

Required tools and equipment

Equipment	Article number	Note
Lifting aid	3HAC077788-001	For joint units on axes 1, 2 and 3 of CRB 15000-5/0.95. Attachment screws M4x35 (4 pcs) are enclosed.
Lifting aid	3HAC087787-001	For joint units on axes 1 and 2 of CRB 15000-10/1.52 and CRB 15000-12/1.27. A plate, a beam, a pair of semicircular blocks and attachment screws M5x30 (2 pcs) are enclosed.
Guide pin, M4x120	3HAC077786-001	Always use guide pins in pairs. For joint units on axes 1, 2 and 3 of CRB 15000-5/0.95 and axis 3 of CRB 15000-10/1.52 and CRB 15000-12/1.27.
Guide pin, M5x125	3HAC087786-001	Always use guide pins in pairs. For joint units on axes 1 and 2 of CRB 15000-10/1.52 and CRB 15000-12/1.27.
Protection plate	3HAC077790-001	For protection of drive board during cabling installation on joint units of CRB 15000-5/0.95.
Protection plate	3HAC087789-001	For protection of drive board during cabling installation on joint units of CRB 15000-10/1.52 and CRB 15000-12/1.27.
Guide pin, M5x75	3HAC087786-002	Always use guide pins in pairs.

Continues on next page

Equipment	Article number	Note
Cable tie gun EVO 7i	-	HellermannTyton 110-77001 or similar
Standard toolkit	-	Content is defined in section Standard toolkit on page 1099 .

Required consumables

Consumable	Article number	Note
Cable ties	-	
O-ring	3HAB3772-64	Base cover, used for CRB 15000-5/0.95.
O-ring	3HAC061327-072	Base cover, used for CRB 15000-10/1.52 and CRB 15000-12/1.27.
O-ring	3HAC061327-044	Lower arm, inner cover of CRB 15000-5/0.95. 1 pcs / cover. Replace if damaged.
O-ring	3HAC061327-075	Lower arm, lower inner cover of CRB 15000-10/1.52 and CRB 15000-12/1.27. Replace if damaged.
O-ring	3HAC061327-047	Cover for axis 2/3, used for CRB 15000-5/0.95. Replace if damaged.
O-ring	3HAC061327-074	Swing cover, used for CRB 15000-10/1.52 and CRB 15000-12/1.27. Replace if damaged.
Grease	3HAC042536-001	Shell Gadus S2
Cleaning agent	-	Isopropanol
Flange sealant	-	Loctite 574

Continues on next page

5 Repair



5.3.2 Replacing the axis-1 cabling

Continued

Removing the joint cabling (-5/0.95)

Use these procedures to remove the joint-1 cabling.

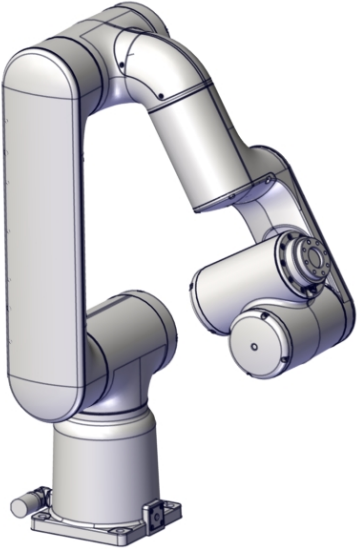
Preparations before removing the cabling

	Action	Note
1	Jog the robot to the specified position: <ul style="list-style-type: none">• Axis 1: 0°• Axis 2: 0°• Axis 3: +60°• Axis 4: 0°• Axis 5: -90°• Axis 6: No significance.	 xx2100000044
2	 CAUTION Turn off all supplies for electrical power to the robot, before starting the repair work.	

Removing the lower arm covers (-5/0.95)

	Action	Note
1	 CAUTION Make sure that all supplies for electrical power are turned off.	

Continues on next page

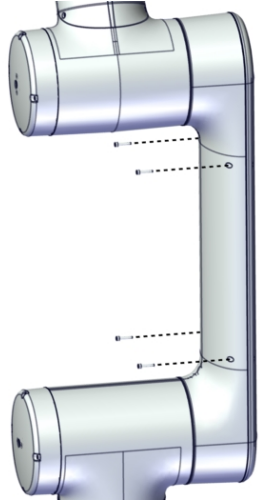
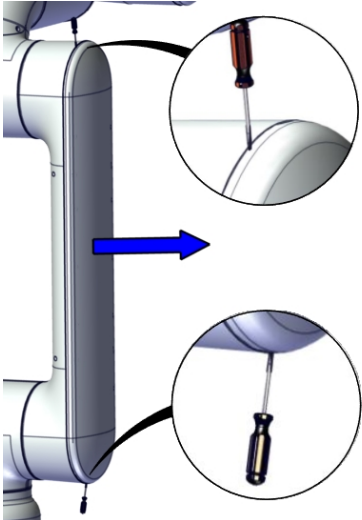
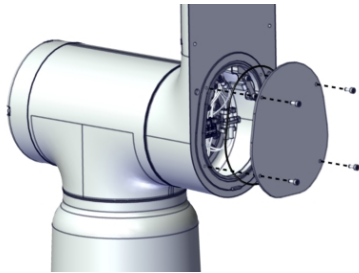
	Action	Note
2	Remove the four lower arm cover screws.	 <p>xx2000001929</p>
3	Remove the cover by inserting a small flat screwdriver to snap open the locks at each end of the cover.	 <p>xx2100000267</p>
4	Remove the inner cover by removing the four screws.	 <p>xx2000001930</p>

Continues on next page

5 Repair

5.3.2 Replacing the axis-1 cabling

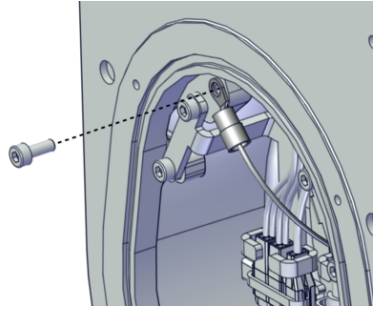
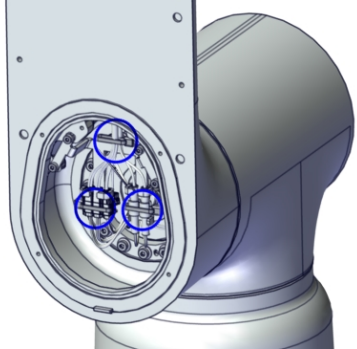
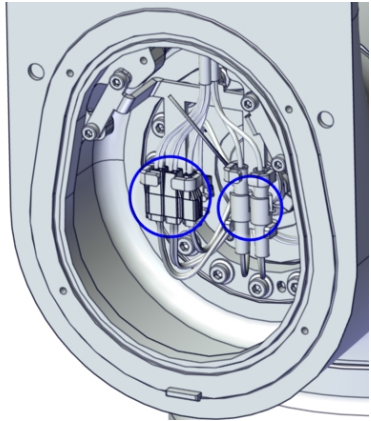

Continued

Disconnecting the cabling between the lower arm and the swing

	Action	Note
1	Remove the functional earth cable by removing the screw.	 xx2000001936
2	Cut the cable ties.	 xx2000001937
3	Snap loose and disconnect all connectors.	 xx2000001938

Continues on next page

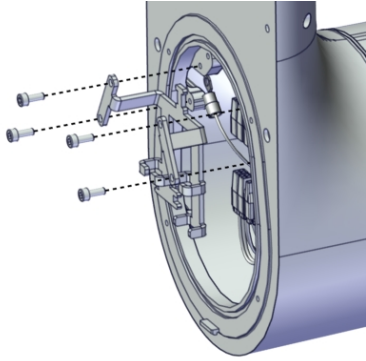
Removing the lower and upper arm assembled

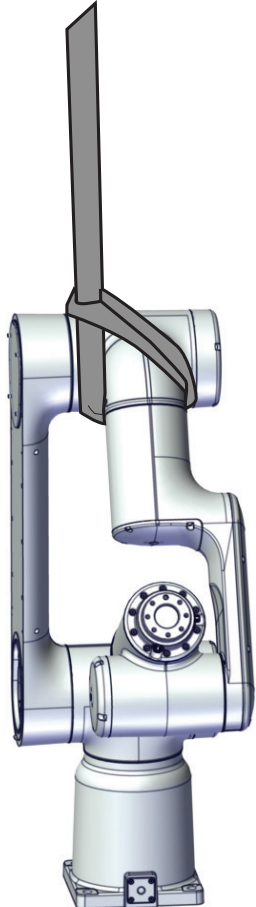

	Action	Note
1	Remove the cable bracket by removing the four screws.	 <p>xx200001939</p>
2	Secure the weight of the upper and lower arm.  CAUTION The weight of the complete upper and lower arm together is 18 kg	Suggestion with lifting sling and an overhead crane. Example of CRB 15000-5/0.95, similar to CRB 15000-10/1.52 and CRB 15000-12/1.27.  <p>xx210000294</p>

Continues on next page

5 Repair

5.3.2 Replacing the axis-1 cabling

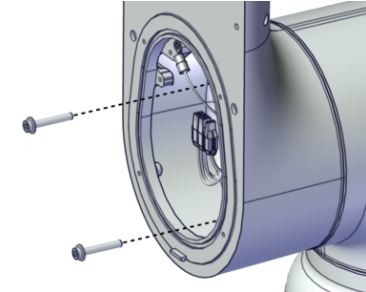
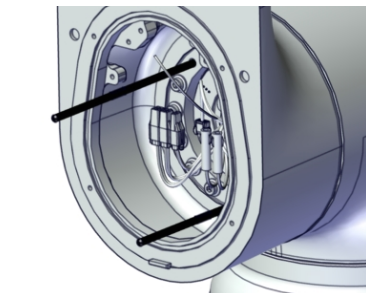
Continued

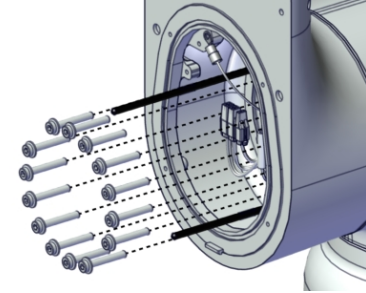
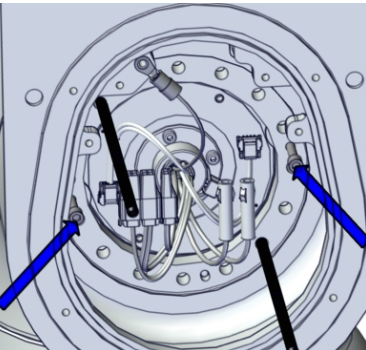
	Action	Note
3	<p>Remove two attachment screws and fit two guide pins to the axis-2 joint unit.</p> <p> CAUTION</p> <p>Do not mix the flange screws used for CRB 15000-5/0.95 and the threaded screws used for CRB 15000-10/1.52 and CRB 15000-12/1.27. Always use washers together with the threaded screws for CRB 15000-10/1.52 and CRB 15000-12/1.27. Illustration is for reference only.</p>	<p>Guide pin, M4x120: 3HAC077786-001</p> <p>Always use guide pins in pairs.</p>  <p>xx2000001951</p>  <p>xx2000001960</p>
4	<p>Remove the lower arm attachment screws.</p> <p> CAUTION</p> <p>Do not mix the flange screws used for CRB 15000-5/0.95 and the threaded screws used for CRB 15000-10/1.52 and CRB 15000-12/1.27. Always use washers together with the threaded screws for CRB 15000-10/1.52 and CRB 15000-12/1.27. Illustration is for reference only.</p>	 <p>xx2000001940</p>
5	<p>Use two fully threaded attachment screws as removal tools to press the lower arm out of position.</p>	 <p>xx2000002151</p>

Continues on next page

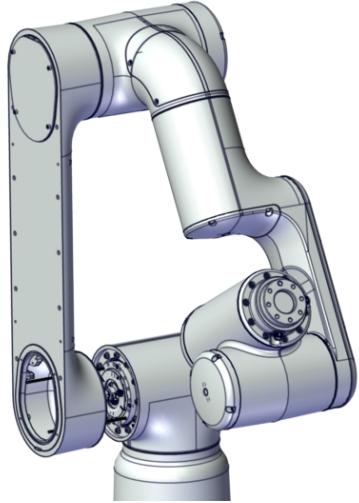
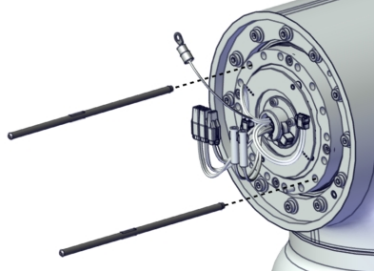
	Action	Note
6	Remove the complete arm system from the swing.	 <p>xx2000001941</p>
7	Remove the guide pins.	 <p>xx2000002432</p>

Removing the swing cover (-5/0.95)

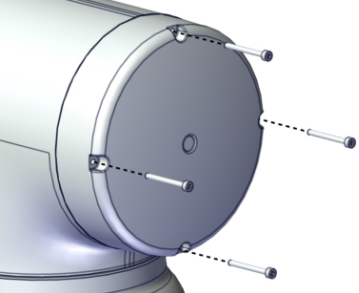
	Action	Note
1	 CAUTION Make sure that all supplies for electrical power are turned off.	
2	Remove the cover screws.	 <p>xx2000001935</p>

Continues on next page

5 Repair

5.3.2 Replacing the axis-1 cabling

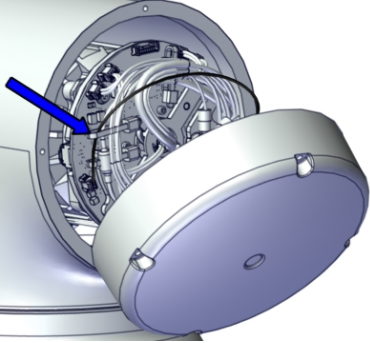
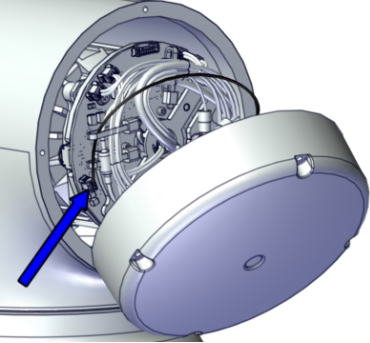

Continued

	Action	Note
3	<p> CAUTION</p> <p>Valid for CRB 15000-5/0.95</p> <p>There is cabling connected between the cover and the joint unit drive board.</p> <p>Open the cover with care to avoid damage to the cabling or the connector(s).</p> <p>Do not leave the cover in location without being secured with the attachment screws.</p>	
4	<p>For robots with RobotWare earlier than 7.10</p> <p>Open the cover and cut the cable tie that holds the brake release cable.</p>	 <p>xx2000001931</p>
5	<p>For robots with RobotWare earlier than 7.10</p> <p>Disconnect the brake release connector DR.X8 from the drive board.</p> <p>Remove the cover.</p>	 <p>xx2000001932</p>

Disconnecting the axis-2 joint unit cabling

	Action	Note
1	<p> ELECTROSTATIC DISCHARGE (ESD)</p> <p>The unit is sensitive to ESD. Before handling the unit read the safety information in section The unit is sensitive to ESD on page 53.</p>	

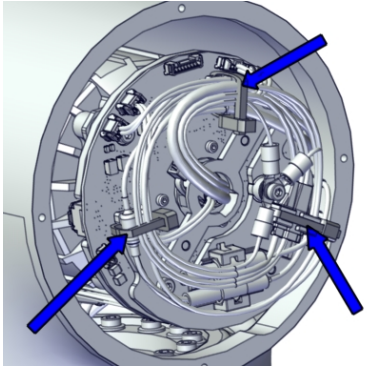
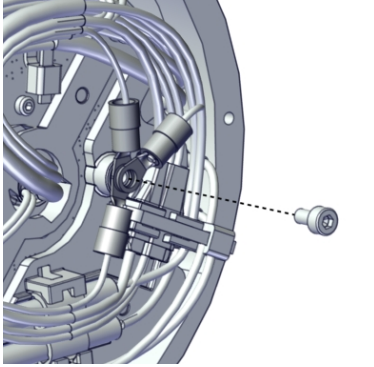
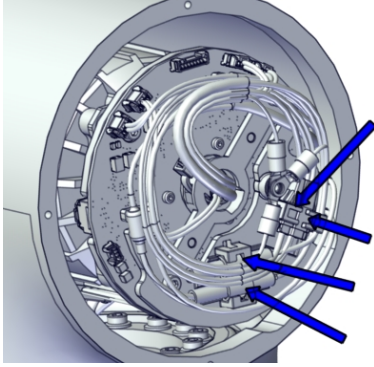
Continues on next page

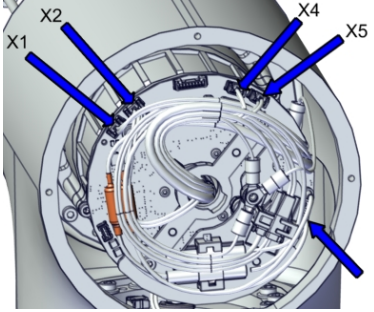
	Action	Note
2	Cut the cable ties.	 <p>xx2000001946</p>
3	Remove the functional and protective earth cables by removing the screw.	 <p>xx2000001945</p>
4	Snap loose and disconnect the connectors: <ul style="list-style-type: none"> • J2.DC+ • J2.DC- • J2.CS • J2.CP 	 <p>xx2000001944</p>
5	Disconnect the connectors from the drive board. <ul style="list-style-type: none"> • D2.X1 from X1 • D2.DC+ from DC+ • D2.DC- from ground • D2.X4 from X4 • D2.X2 from X2 • D2.X5 from X5 <p> CAUTION</p> Use tweezers to unlock connectors and pull them off.	 <p>xx2000002013</p>

Continues on next page

5 Repair



5.3.2 Replacing the axis-1 cabling

Continued

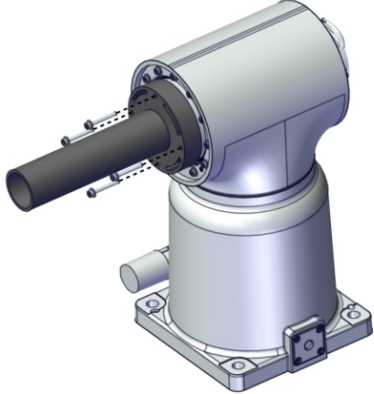
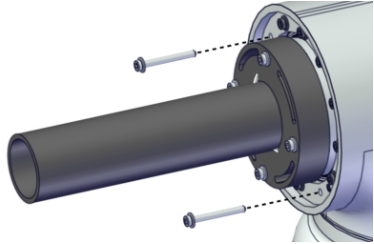
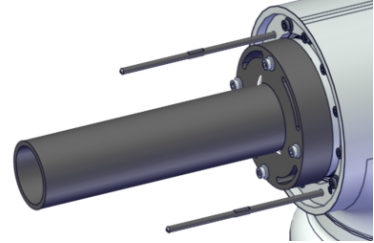
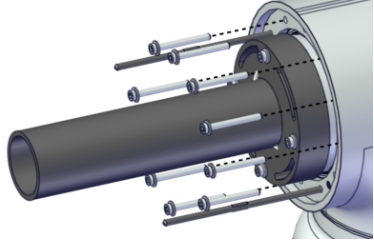
Removing the axis-2 joint unit (-5/0.95)

	Action	Note
1	<p>Fit the lifting aid to the joint unit, on the torque sensor side.</p> <p> CAUTION</p> <p>The connectors and the joint unit cables are sensitive to mechanical damage. Handle the assembly with care.</p>	<p>Lifting aid: 3HAC077788-001 Screws: M4x35 (4 pcs)</p>  <p>xx2000001956</p>
2	<p>Remove two attachment screws. Dispose the screws. New screws are included in the spare part delivery of the joint unit.</p>	 <p>xx2100000295</p>
3	<p>Fit two guide pins to the axis-2 joint unit.</p>	<p>Guide pin, M4x120: 3HAC077786-001 Always use guide pins in pairs. For joint units on axes 1, 2 and 3 of CRB 15000-5/0.95 and axis 3 of CRB 15000-10/1.52 and CRB 15000-12/1.27.</p>  <p>xx2000002433</p>
4	<p>Remove the remaining attachment screws. Use two screws as press out screws in the upcoming step, then dispose all screws. New screws are included in the spare part delivery of the joint unit.</p>	 <p>xx2000001943</p>

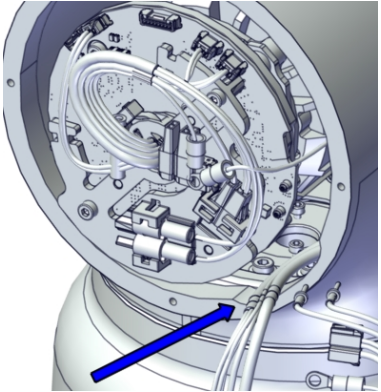
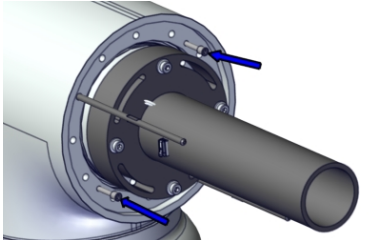
Continues on next page

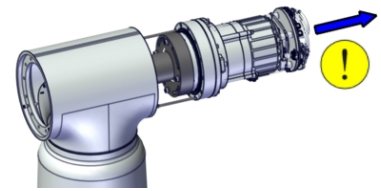
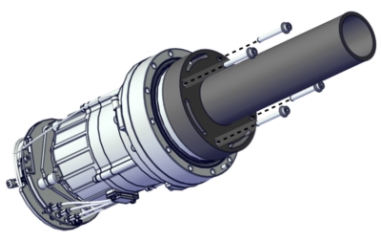
	Action	Note
5	Put the cabling at the slot in order not to squeeze it during removal of joint unit.	 <p>xx210000045</p>
6	Press the joint unit out of position using two of the previous attachment screws as removal tools.	 <p>xx2000002434</p>
7	<p>Remove the joint unit from the swing.</p> <p> CAUTION</p> <p>The connectors and the joint unit cables are sensitive to mechanical damage. Handle the assembly with care.</p>	 <p>xx2000001958</p>
8	Remove the lifting aid and guide pins.	 <p>xx2000001957</p>





Continues on next page

5 Repair

5.3.2 Replacing the axis-1 cabling

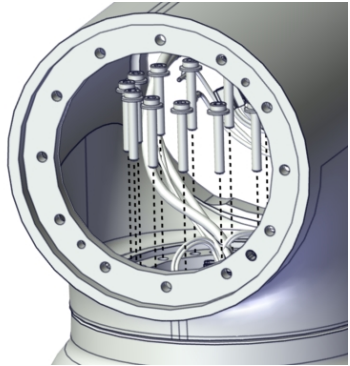
Continued

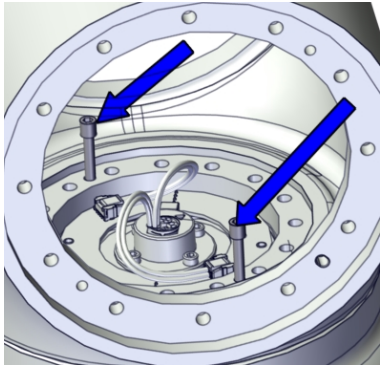
Removing the swing (-5/0.95)

	Action	Note
1	<p>Remove the swing attachment screws.</p> <p> CAUTION</p> <p>Do not mix the flange screws used for CRB 15000-5/0.95 and the threaded screws used for CRB 15000-10/1.52 and CRB 15000-12/1.27. Always use washers together with the threaded screws for CRB 15000-10/1.52 and CRB 15000-12/1.27. Illustration is for reference only.</p>	 <p>xx2000001987</p>
2	<p>Use two fully threaded attachment screws as removal tools to press the swing out of position.</p> <p> CAUTION</p> <p>Do not mix the flange screws used for CRB 15000-5/0.95 and the threaded screws used for CRB 15000-10/1.52 and CRB 15000-12/1.27. Always use washers together with the threaded screws for CRB 15000-10/1.52 and CRB 15000-12/1.27. Illustration is for reference only.</p>	 <p>xx2000002152</p>
3	<p>Lift away the swing.</p> <p> CAUTION</p> <p>The torque sensor (on the exposed PCBA) is sensitive to mechanical damage. Handle the assembly with care.</p>	

Loosening the base and removing the base cover

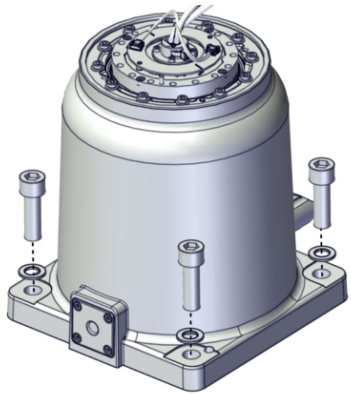
	Action	Note
1	<p>Loosen the base from the foundation by removing the attachment screws and washers.</p>	 <p>xx2000002006</p>

Continues on next page

5.3.2 Replacing the axis-1 cabling
Continued

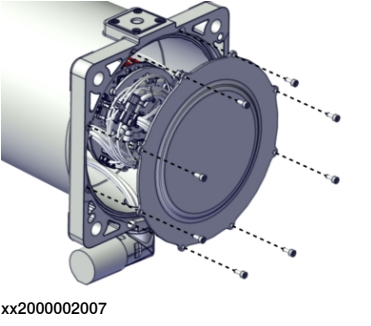
	Action	Note
2	Tilt the base on to its side and remove the bottom cover by removing the attachment screws.	 <p>xx2000002007</p>

Disconnecting the axis-1 joint unit cabling

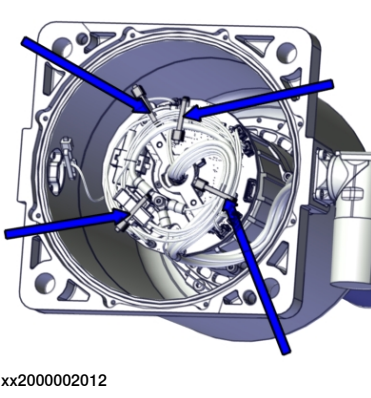
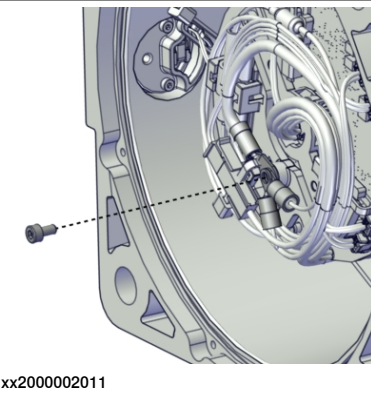
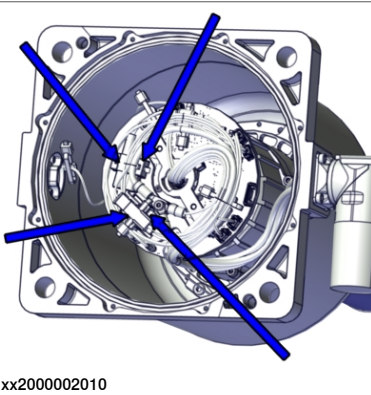
	Action	Note
1	Cut the cable ties.	 <p>xx2000002012</p>
2	Remove the functional and protective earth cables by removing the screw.	 <p>xx2000002011</p>
3	Snap loose and disconnect the connectors: <ul style="list-style-type: none"> • J1.DC+ • J1.DC- • J1.CS • J1.CP 	 <p>xx2000002010</p>

Continues on next page



5 Repair

5.3.2 Replacing the axis-1 cabling

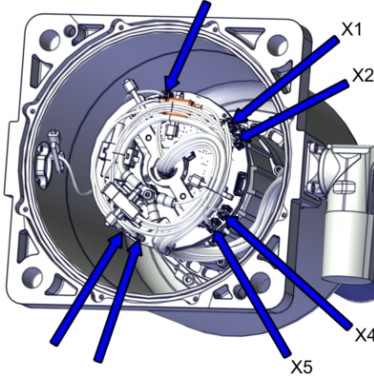
Continued

	Action	Note
4	<p>Disconnect the connectors from the drive board.</p> <ul style="list-style-type: none"> • D1.X1 from X1 • D1.DC+ from DC+ • D1.DC- from ground • D1.X4 from X4 • D1.X2 from X2 • D1.X5 from X5 • DR.X8 from X8 <p> CAUTION</p> <p>Use tweezers to unlock connectors and pull them off.</p>	 <p>xx2000002009</p>

Removing the joint cable

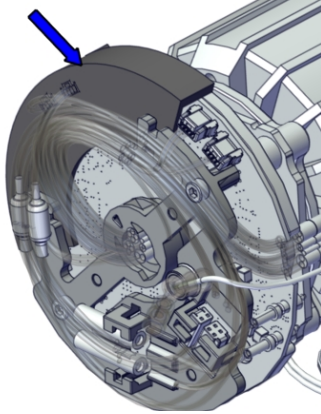
	Action	Note
1	<p> ELECTROSTATIC DISCHARGE (ESD)</p> <p>The unit is sensitive to ESD. Before handling the unit read the safety information in section The unit is sensitive to ESD on page 53.</p>	
2	<p> Tip</p> <p>Using the protection plate is important for protecting the drive board unit. If complete joint unit is to be replaced, the protection plate is not needed.</p>	<p>Protection plate: 3HAC077790-001 (for CRB 15000-5/0.95) / 3HAC087789-001 (for CRB 15000-10/1.52 and CRB 15000-12/1.27)</p>  <p>xx2000002057</p>

Continues on next page

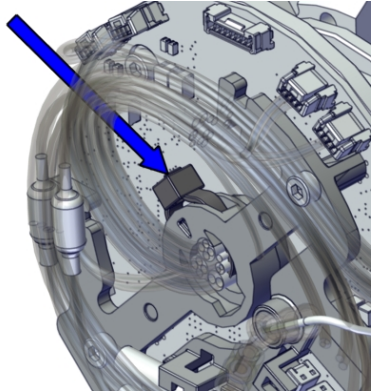
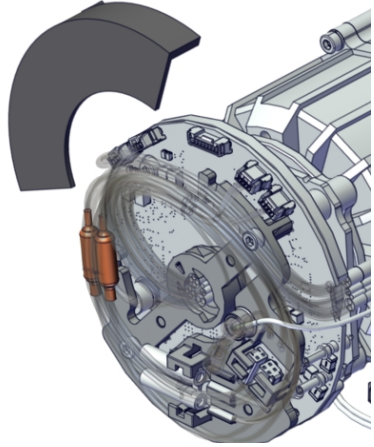
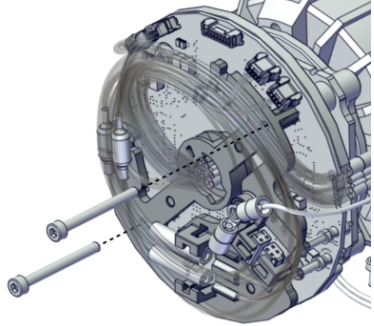
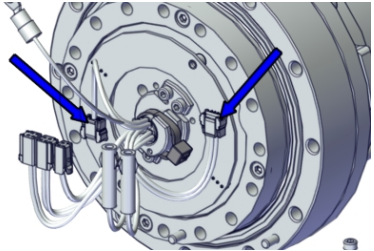

	Action	Note
3	Cut the cable tie at the drive board.	 <p>xx2000002058</p>
4	Remove the protection plate.	 <p>xx2100000301</p>
5	Remove the cable support from the drive board by removing the attachment screws.	 <p>xx2000002055</p>
6	Disconnect the two connectors from the torque sensor board. <ul style="list-style-type: none"> • TQ.A • TQ.B 	 <p>xx2000002053</p>

Continues on next page

5 Repair

5.3.2 Replacing the axis-1 cabling

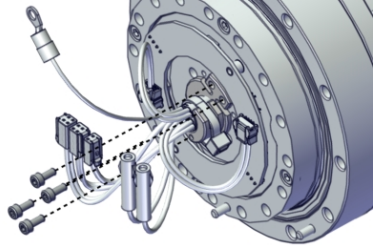
Continued

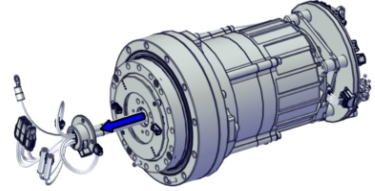

	Action	Note
7	Remove the cable plate by removing the attachment screws.	 <p>xx2000002049</p>
8	<p>Remove the joint cable from the hollow shaft from the torque sensor side.</p> <p> CAUTION</p> <p>The connectors and the joint unit cables are sensitive to mechanical damage. Handle the assembly with care.</p>	 <p>xx2000002060</p>

Continues on next page

Removing the joint cabling (-10/1.52 and -12/1.27)

Use these procedures to remove the joint-1 cabling.

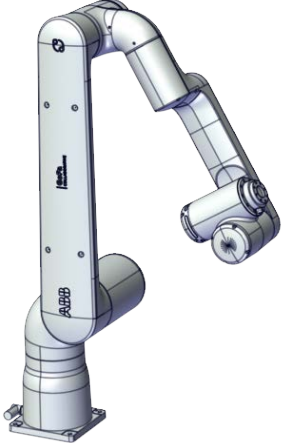
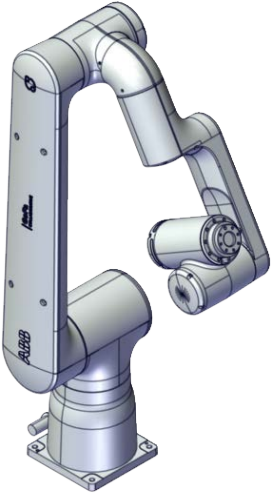
Preparations before removing the cabling

	Action	Note
1	Jog the robot to the specified position: <ul style="list-style-type: none"> • Axis 1: 0° • Axis 2: 0° • Axis 3: +60° • Axis 4: 0° • Axis 5: -90° • Axis 6: No significance. 	<p>Valid for CRB 15000-10/1.52</p>  <p>xx2300001062</p> <p>Valid for CRB 15000-12/1.27</p>  <p>xx2300001063</p>
2	 <p>CAUTION</p> <p>Turn off all supplies for electrical power to the robot, before starting the repair work.</p>	

Continues on next page

5 Repair

5.3.2 Replacing the axis-1 cabling

Continued

Removing the lower arm covers (-10/1.52 and -12/1.27)

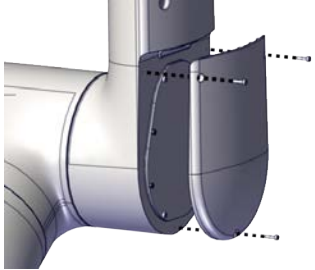
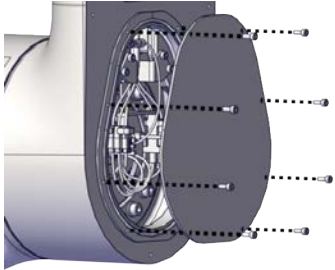
	Action	Note
1	 CAUTION Make sure that all supplies for electrical power are turned off.	
2	Remove the lower cover of lower arm by removing the screws.	 xx2300000812
3	Remove the lower inner cover by removing the screws.	 xx2300000813

Disconnecting the cabling between the lower arm and the swing

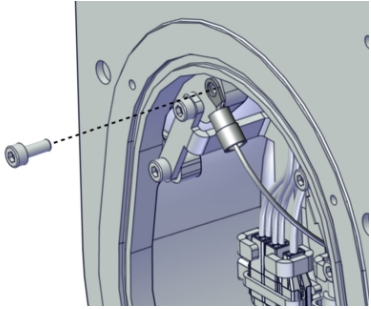
	Action	Note
1	Remove the functional earth cable by removing the screw.	 xx2000001936

Continues on next page

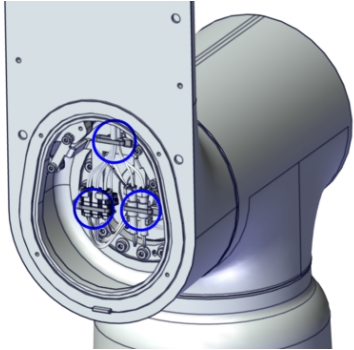
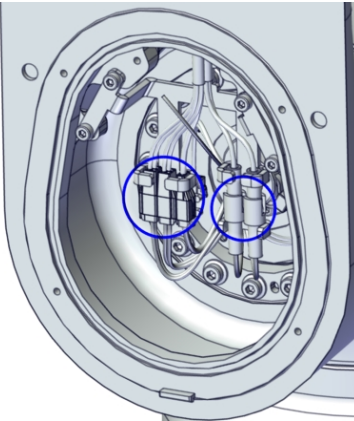
	Action	Note
2	Cut the cable ties.	 <p>xx2000001937</p>
3	Snap loose and disconnect all connectors.	 <p>xx2000001938</p>

Removing the lower and upper arm assembled

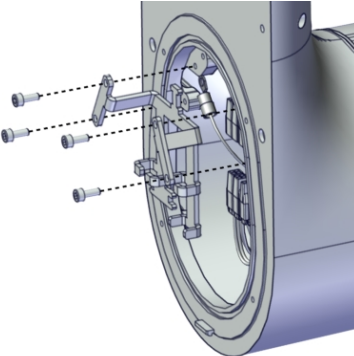
	Action	Note
1	Remove the cable bracket by removing the four screws.	 <p>xx2000001939</p>

Continues on next page



5 Repair

5.3.2 Replacing the axis-1 cabling

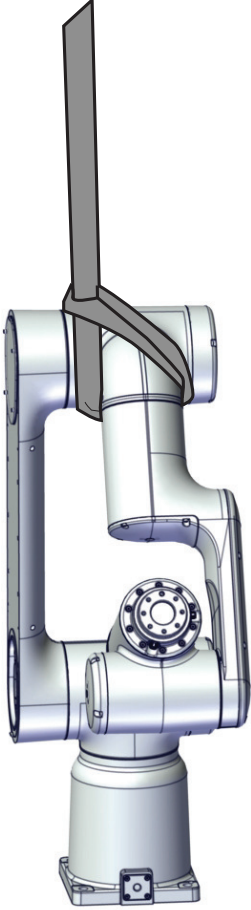
Continued

	Action	Note
2	<p>Secure the weight of the upper and lower arm.</p> <p> CAUTION</p> <p>The weight of the complete upper and lower arm together is up to 26 kg</p>	<p>Suggestion with lifting sling and an overhead crane.</p> <p>Example of CRB 15000-5/0.95, similar to CRB 15000-10/1.52 and CRB 15000-12/1.27.</p>  <p>xx2100000294</p>

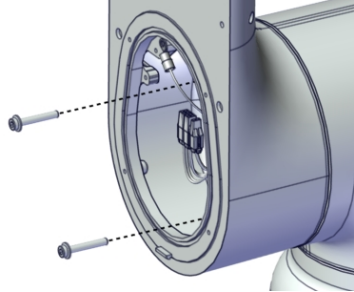
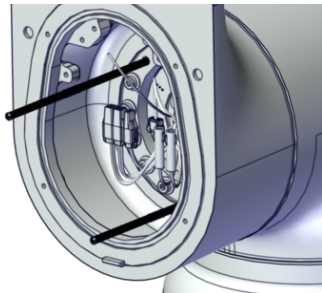
Continues on next page

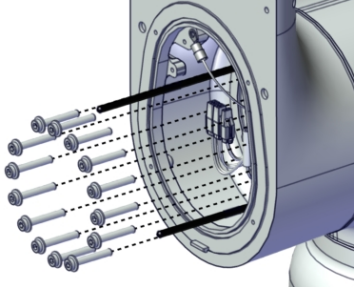
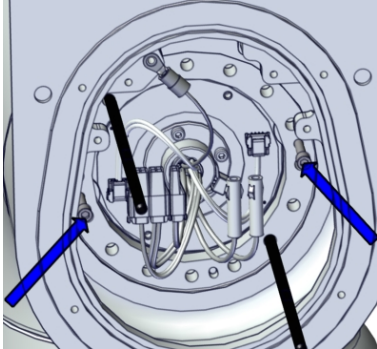
	Action	Note
3	<p>Remove two attachment screws and fit two guide pins to the axis-2 joint unit.</p> <p> CAUTION</p> <p>Do not mix the flange screws used for CRB 15000-5/0.95 and the threaded screws used for CRB 15000-10/1.52 and CRB 15000-12/1.27. Always use washers together with the threaded screws for CRB 15000-10/1.52 and CRB 15000-12/1.27. Illustration is for reference only.</p>	<p>Guide pin, M5x125: 3HAC087786-001</p> <p>Always use guide pins in pairs.</p>  <p>xx2000001951</p>  <p>xx2000001960</p>
4	<p>Remove the lower arm attachment screws.</p> <p> CAUTION</p> <p>Do not mix the flange screws used for CRB 15000-5/0.95 and the threaded screws used for CRB 15000-10/1.52 and CRB 15000-12/1.27. Always use washers together with the threaded screws for CRB 15000-10/1.52 and CRB 15000-12/1.27. Illustration is for reference only.</p>	 <p>xx2000001940</p>
5	<p>Use two fully threaded attachment screws as removal tools to press the lower arm out of position.</p>	 <p>xx2000002151</p>

Continues on next page

5 Repair

5.3.2 Replacing the axis-1 cabling

Continued

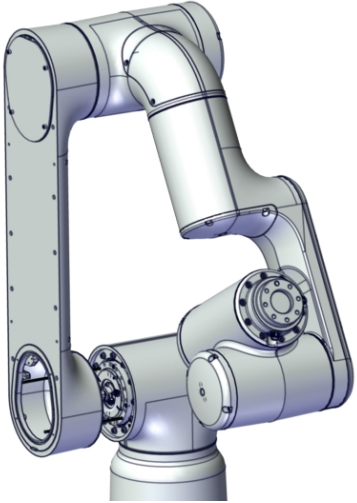
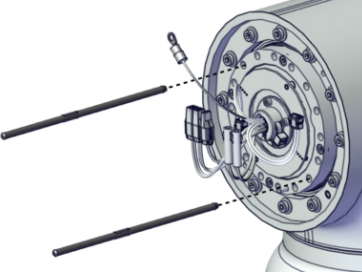
	Action	Note
6	Remove the complete arm system from the swing.	 <p>xx2000001941</p>
7	Remove the guide pins.	 <p>xx2000002432</p>

Removing the swing cover and insert (-10/1.52 and -12/1.27)

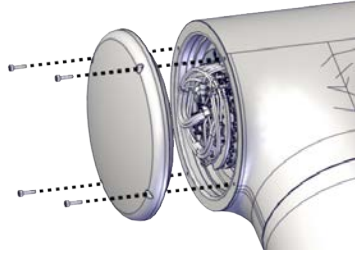
	Action	Note
1	 CAUTION Make sure that all supplies for electrical power are turned off.	
2	Remove the cover by removing the screws.	 <p>xx2300000814</p>

Continues on next page

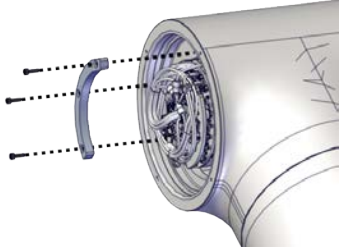
	Action	Note
3	<p> CAUTION</p> <p>Valid for CRB 15000-5/0.95</p> <p>There is cabling connected between the cover and the joint unit drive board.</p> <p>Open the cover with care to avoid damage to the cabling or the connector(s).</p> <p>Do not leave the cover in location without being secured with the attachment screws.</p>	
4	Remove the insert.	 <p>xx2300000815</p>

Disconnecting the axis-2 joint unit cabling

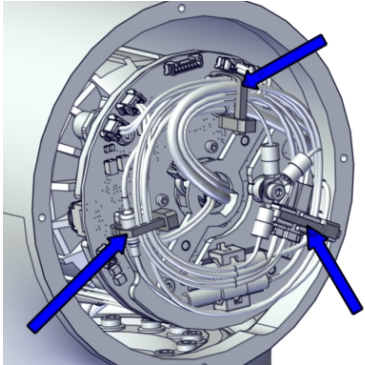

	Action	Note
1	<p> ELECTROSTATIC DISCHARGE (ESD)</p> <p>The unit is sensitive to ESD. Before handling the unit read the safety information in section The unit is sensitive to ESD on page 53.</p>	
2	Cut the cable ties.	 <p>xx2000001946</p>

Continues on next page

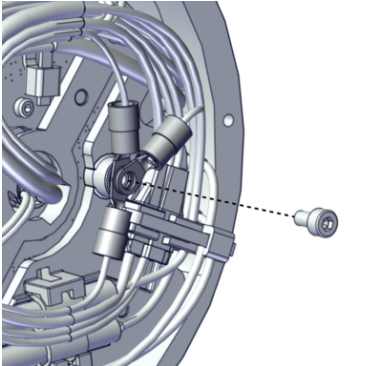
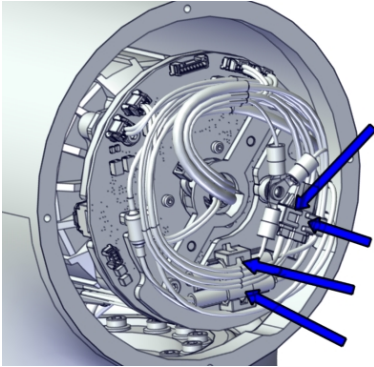

5 Repair

5.3.2 Replacing the axis-1 cabling

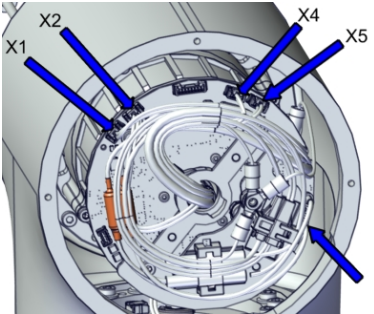

Continued

	Action	Note
3	Remove the functional and protective earth cables by removing the screw.	 <p>xx2000001945</p>
4	Snap loose and disconnect the connectors: <ul style="list-style-type: none"> • J2.DC+ • J2.DC- • J2.CS • J2.CP 	 <p>xx2000001944</p>
5	Disconnect the connectors from the drive board. <ul style="list-style-type: none"> • D2.X1 from X1 • D2.DC+ from DC+ • D2.DC- from ground • D2.X4 from X4 • D2.X2 from X2 • D2.X5 from X5 <p> CAUTION</p> <p>Use tweezers to unlock connectors and pull them off.</p>	 <p>xx2000002013</p>

Removing the base from foundation (-10/1.52 and -12/1.27)

	Action	Note
1	<p> CAUTION</p> <p>The weight of the complete swing and base together is up to 25 kg</p>	
2	<p> WARNING</p> <p>Personnel must not, under any circumstances, be present under the suspended load.</p>	

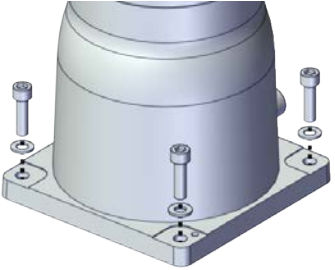
Continues on next page

	Action	Note
3	Loosen the robot base from the foundation by removing the foundation attachment screws.	 <p>xx2300001060</p>
4	<p>Lay the robot down with the torque sensor side upwards on a working bench. Do not damage the base socket. Caution with the cabling.</p> <p> CAUTION</p> <p>The cabling is sensitive to mechanical damage. Handle it with care to avoid damage to the cabling or the connector, avoid any kind of tilt or skew.</p>	

Removing the axis-2 joint unit

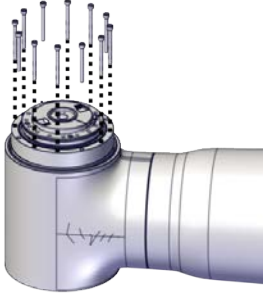



	Action	Note
1	Removing the attachment screws.	 <p>xx2300000786</p>

Continues on next page

5 Repair

5.3.2 Replacing the axis-1 cabling

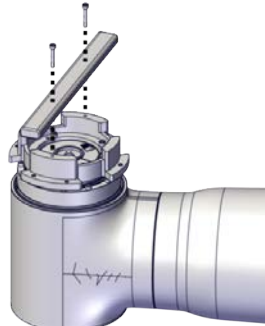
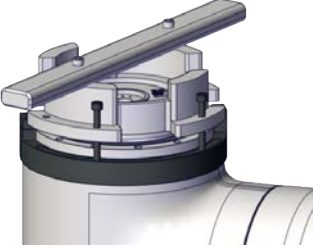
Continued

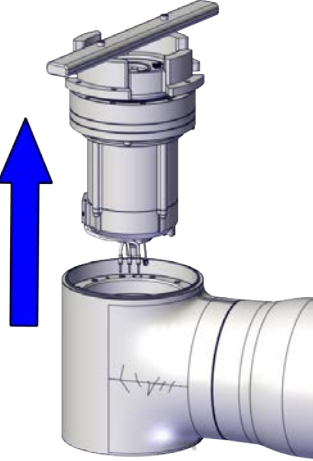
	Action	Note
2	<p>Fit the lifting aid to the joint unit, on the torque sensor side.</p> <p> CAUTION</p> <p>The connectors and the joint unit cables are sensitive to mechanical damage. Handle the assembly with care.</p>	<p>Lifting aid: 3HAC087787-001 Screws: M5x30 (4 pcs for plate and 2 pcs for beam)</p>  <p>xx2300000787</p>  <p>xx2300000788</p>
3	<p>Place the two semicircular blocks surrounding the joint unit, and use two fully threaded attachment screws as removal tools to press the joint unit out of position.</p>	 <p>xx2300000789</p>
4	<p>Remove the joint unit from the swing.</p> <p> CAUTION</p> <p>The connectors and the joint unit cables are sensitive to mechanical damage. Handle the assembly with care.</p>	 <p>xx2300000790</p>

Continues on next page

	Action	Note
5	Remove the lifting aid.	 <p data-bbox="1059 645 1166 667">xx2300000778</p> <p data-bbox="1059 1021 1166 1043">xx2300000776</p>

Securing the base (-10/1.52 and -12/1.27)

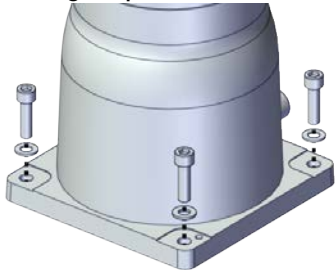
	Action	Note
1	Lift the base to standing and secure it to the foundation with the attachment screws and washers.	<p data-bbox="1023 1193 1406 1249">Attachment screws: M10x35 8.8 (4 pcs).</p> <p data-bbox="1023 1252 1437 1285">Washers: 23/10.5/2.5 mm Steel (4 pcs).</p> <p data-bbox="1023 1288 1382 1321">Tightening torque: 32 Nm \pm10%.</p>  <p data-bbox="1023 1619 1129 1641">xx2300001060</p>



Continues on next page

5 Repair

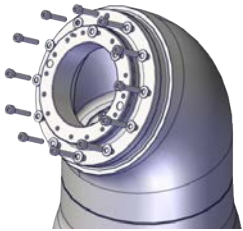

5.3.2 Replacing the axis-1 cabling

Continued

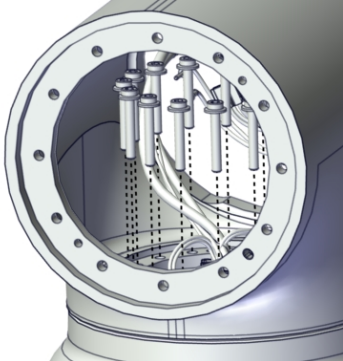
Removing the swing (-10/1.52 and -12/1.27)

	Action	Note
1	<p>Valid for CRB 15000-10/1.52</p> <p>Remove the swing transition.</p>	 <p>xx2300000817</p>
2	<p>Valid for CRB 15000-10/1.52</p> <p>Remove the swing flange.</p>	 <p>xx2300000818</p>
3	<p>Remove the swing attachment screws.</p> <p> CAUTION</p> <p>Do not mix the flange screws used for CRB 15000-5/0.95 and the threaded screws used for CRB 15000-10/1.52 and CRB 15000-12/1.27. Always use washers together with the threaded screws for CRB 15000-10/1.52 and CRB 15000-12/1.27. Illustration is for reference only.</p>	<p>Valid for CRB 15000-10/1.52</p>  <p>xx2300000819</p> <p>Valid for CRB 15000-12/1.27</p>  <p>xx2000001987</p>

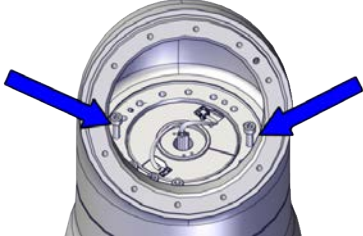
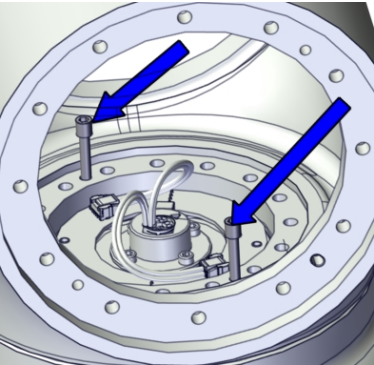
Continues on next page

	Action	Note
4	<p>Use two fully threaded attachment screws as removal tools to press the swing out of position.</p> <p> CAUTION</p> <p>Do not mix the flange screws used for CRB 15000-5/0.95 and the threaded screws used for CRB 15000-10/1.52 and CRB 15000-12/1.27. Always use washers together with the threaded screws for CRB 15000-10/1.52 and CRB 15000-12/1.27. Illustration is for reference only.</p>	<p>Valid for CRB 15000-10/1.52</p>  <p>xx2300000822</p> <p>Valid for CRB 15000-12/1.27</p>  <p>xx2000002152</p>
5	<p>Lift away the swing.</p> <p> CAUTION</p> <p>The torque sensor (on the exposed PCBA) is sensitive to mechanical damage. Handle the assembly with care.</p>	

Loosening the base and removing the base cover

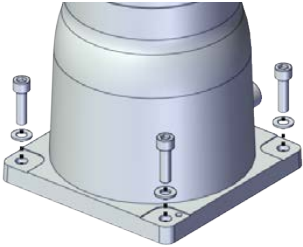
	Action	Note
1	<p>Loosen the base from the foundation by removing the attachment screws and washers.</p>	 <p>xx2300001060</p>

Continues on next page

5 Repair

5.3.2 Replacing the axis-1 cabling

Continued

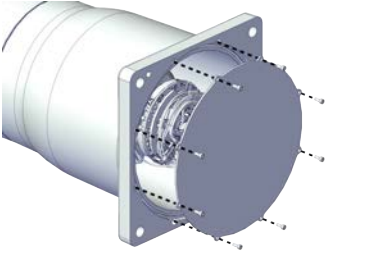
	Action	Note
2	Tilt the base on to its side and remove the bottom cover by removing the attachment screws.	 <p data-bbox="1029 582 1141 604">xx2300000760</p>

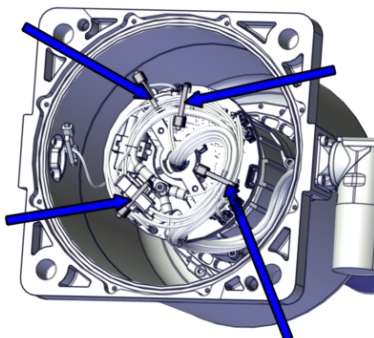
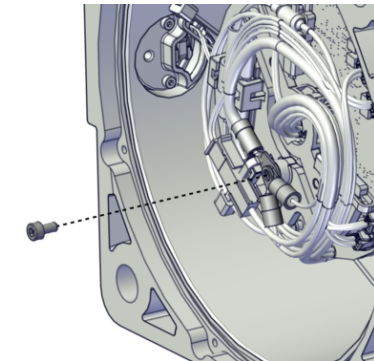
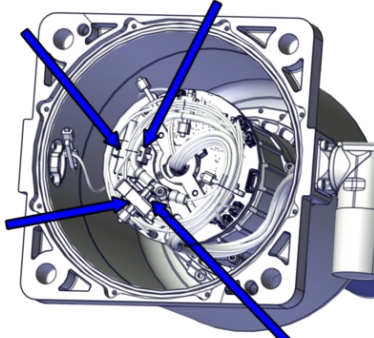

Disconnecting the axis-1 joint unit cabling

	Action	Note
1	Cut the cable ties.	 <p data-bbox="1029 1108 1141 1131">xx2000002012</p>
2	Remove the functional and protective earth cables by removing the screw.	 <p data-bbox="1029 1534 1141 1556">xx2000002011</p>
3	Snap loose and disconnect the connectors: <ul style="list-style-type: none"> • J1.DC+ • J1.DC- • J1.CS • J1.CP 	 <p data-bbox="1029 1937 1141 1960">xx2000002010</p>

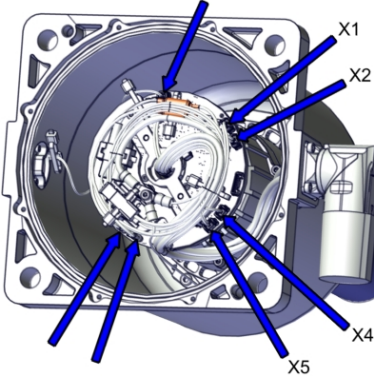
Continues on next page

	Action	Note
4	<p>Disconnect the connectors from the drive board.</p> <ul style="list-style-type: none"> • D1.X1 from X1 • D1.DC+ from DC+ • D1.DC- from ground • D1.X4 from X4 • D1.X2 from X2 • D1.X5 from X5 • DR.X8 from X8 <p> CAUTION</p> <p>Use tweezers to unlock connectors and pull them off.</p>	 <p>xx2000002009</p>

Removing the joint cable

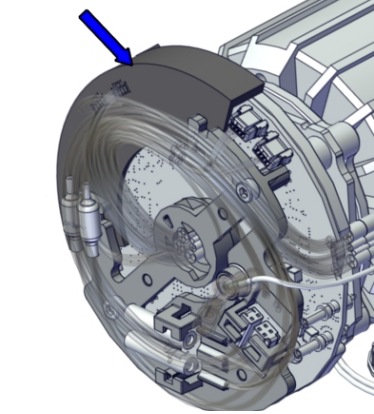
	Action	Note
1	<p> ELECTROSTATIC DISCHARGE (ESD)</p> <p>The unit is sensitive to ESD. Before handling the unit read the safety information in section The unit is sensitive to ESD on page 53.</p>	
2	<p> Tip</p> <p>Using the protection plate is important for protecting the drive board unit. If complete joint unit is to be replaced, the protection plate is not needed.</p>	<p>Protection plate: 3HAC077790-001 (for CRB 15000-5/0.95) / 3HAC087789-001 (for CRB 15000-10/1.52 and CRB 15000-12/1.27)</p>  <p>xx2000002057</p>

Continues on next page



5 Repair

5.3.2 Replacing the axis-1 cabling

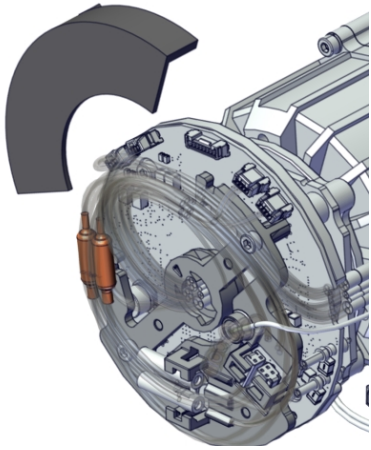
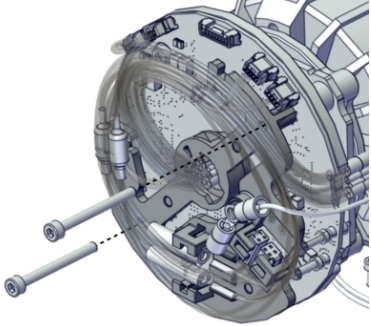
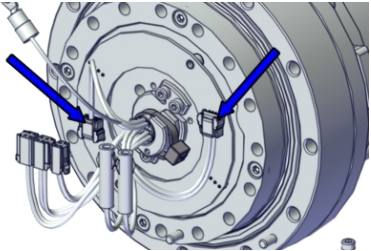
Continued

	Action	Note
3	Cut the cable tie at the drive board.	 xx2000002058
4	Remove the protection plate.	 xx2100000301
5	Remove the cable support from the drive board by removing the attachment screws.	 xx2000002055
6	Disconnect the two connectors from the torque sensor board. <ul style="list-style-type: none">• TQ.A• TQ.B	 xx2000002053

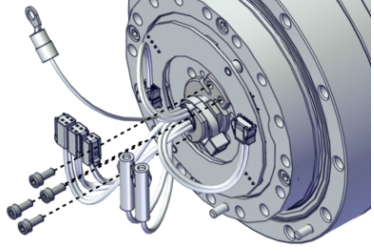

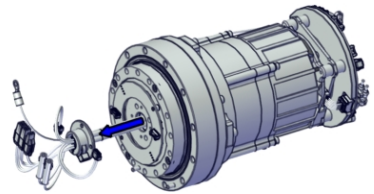
Continues on next page

	Action	Note
7	Remove the cable plate by removing the attachment screws.	 <p>xx2000002049</p>
8	Remove the joint cable from the hollow shaft from the torque sensor side.  CAUTION The connectors and the joint unit cables are sensitive to mechanical damage. Handle the assembly with care.	 <p>xx2000002060</p>

Refitting the joint cabling (-5/0.95)

Use these procedures to refit the joint-1 cabling.

Refitting the joint cable

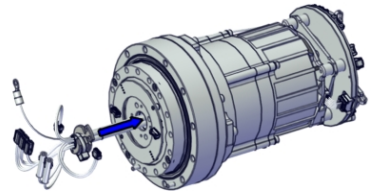
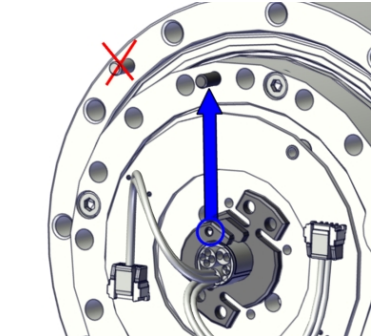
	Action	Note
1	 ELECTROSTATIC DISCHARGE (ESD) The unit is sensitive to ESD. Before handling the unit read the safety information in section The unit is sensitive to ESD on page 53 .	
2	Place the joint cable through the hollow shaft from the torque sensor side.  CAUTION The connectors and the joint unit cables are sensitive to mechanical damage. Handle the assembly with care.	 <p>xx2000002048</p>
3	Orient the cable plate according to the figure. The circle on the cable plate should point towards the guide pin on the torque sensor.	 <p>xx2000002051</p>

Continues on next page

5 Repair

5.3.2 Replacing the axis-1 cabling

Continued

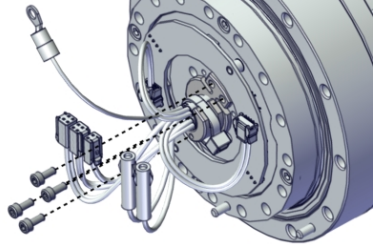
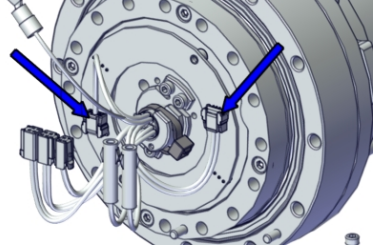
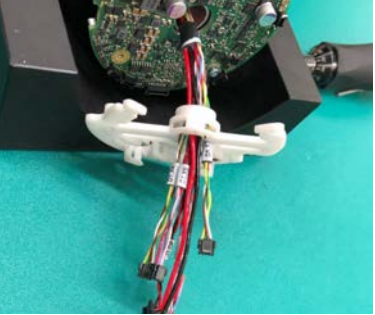
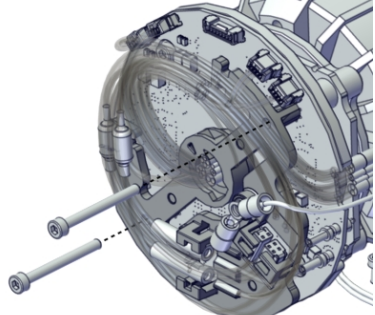
	Action	Note
4	Secure the cable plate to the joint unit with the attachment screws.	<p>Hex socket head cap screw: M2.5x6 12.9 Lafre 2C2B/FC6.9 (4 pcs) Tightening torque: 0.45 Nm.</p>  <p>xx2000002049</p>
5	Connect the two connectors to the torque sensor board. <ul style="list-style-type: none">• TQ.A to CH1/A• TQ.B to CH2/B	 <p>xx2000002053</p>
6	Insert the cabling through the cable support and fit the support to the drive board with the attachment screws.	 <p>xx2000002056</p> <p>Hex socket head cap screw: M3x30 12.9 Lafre 2C2B/FC6.9 (2 pcs) Tightening torque: 0.45 Nm.</p>  <p>xx2000002055</p>

Continues on next page

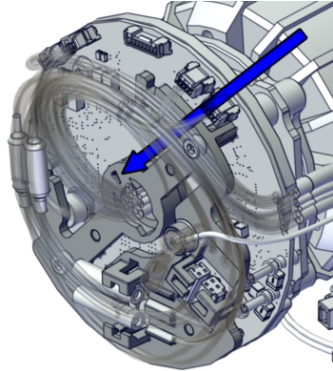
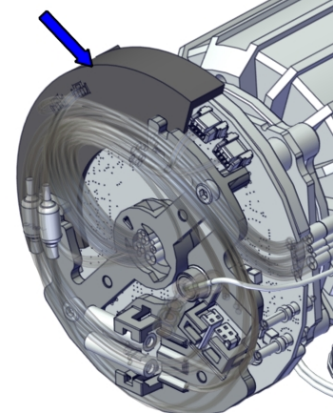
	Action	Note
7	<p>Keep the cabling loose, making sure not to twist or strain it. Use the cable tie to pre-fix the cable by hand.</p>	 <p>xx2100000507</p>
8	<p>Fit the protection plate to the drive board unit.</p>	<p>Protection plate: 3HAC077790-001 (for CRB 15000-5/0.95) / 3HAC087789-001 (for CRB 15000-10/1.52 and CRB 15000-12/1.27)</p>  <p>xx2000002057</p>

Continues on next page

5 Repair

5.3.2 Replacing the axis-1 cabling

Continued

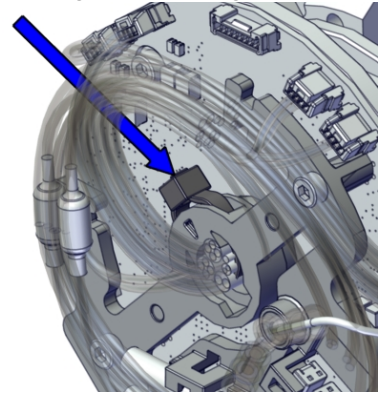
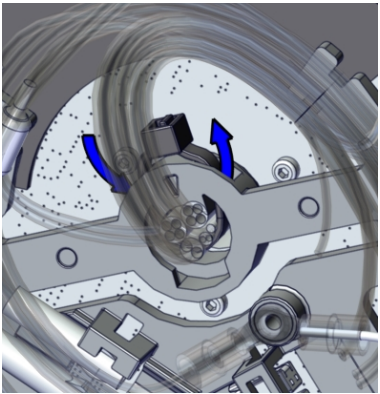
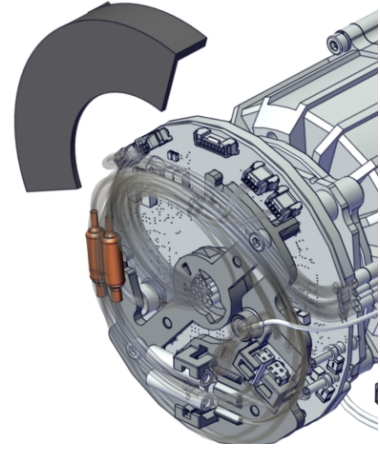
	Action	Note
9	<p>Secure the cables to the cable support with a cable tie, using a cable tie gun.</p> <p>Assembly direction for the cable tie is shown in the figure.</p>	<p>Cable tie: 3HAC075545-001. For securing joint unit cable.</p> <p>Cable tie gun EVO 7i</p> <p>Setting for cable tie gun: 6.75.</p>  <p>xx200002058</p>  <p>xx200002059</p>
10	<p>Remove the protection plate.</p>	 <p>xx210000301</p>

Continues on next page

Connecting the axis-1 joint unit cabling

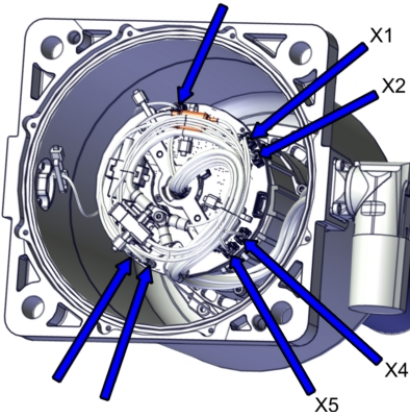
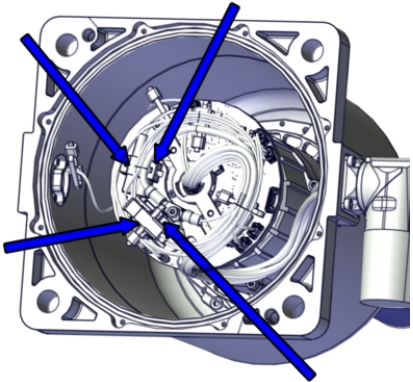
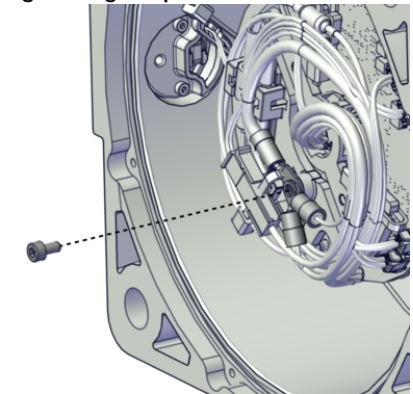
	Action	Note
1	 <p>ELECTROSTATIC DISCHARGE (ESD)</p> <p>The unit is sensitive to ESD. Before handling the unit read the safety information in section <i>The unit is sensitive to ESD on page 53.</i></p>	
2	<p>Reconnect the connectors to the drive board.</p> <ul style="list-style-type: none"> • D1.X1 to X1 • D1.DC+ to DC+ • D1.DC- to Ground • D1.X4 to X4 • D1.X2 to X2 • D1.X5 to X5 • DR.X8 to X8 	 <p>xx200000209</p>
3	<p>Connect the connectors to each other and snap them to the cable holders.</p> <ul style="list-style-type: none"> • J1.DC+ to J1.DC+ • J1.DC- to J1.DC- • J1.CS to J1.CS • J1.CP to J1.CP 	 <p>xx200000210</p>
4	<p>Secure the cables for functional earth and protective earth with a screw.</p>	<p>Hex socket head cap screw: M3x6 (1 pcs).</p> <p>Tightening torque: 0.8 Nm.</p>  <p>xx200000211</p>

Continues on next page

5 Repair

5.3.2 Replacing the axis-1 cabling

Continued

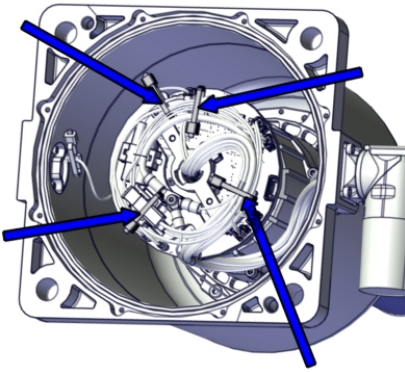
	Action	Note
5	Secure the cabling with cable ties.	Cable ties (4 pcs)  xx2000002012

Refitting the base cover (-5/0.95)

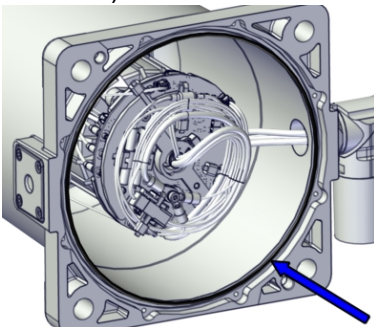
	Action	Note
1	Wipe, lubricate and fit the o-ring to its groove. Replace if damaged.	O-ring: 3HAB3772-64 Grease: 3HAC042536-001 (Shell Gadus S2)  xx2000002016

Continues on next page

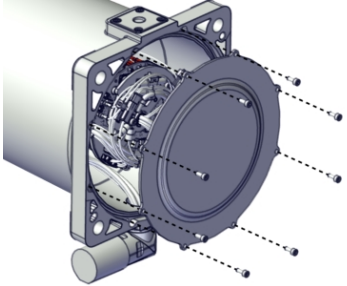
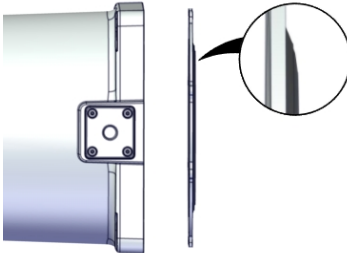
	Action	Note
2	<p>Refit the bottom cover with the attachment screws.</p> <p> Note</p> <p>For CRB 15000-5/0.95, fit the cover in correct direction, the protrusion of the cover must face outwards.</p>	<p>Hex socket head cap screw: M3x8 12.9 Lafre 2C2B/FC6.9 (8 pcs) Tightening torque: 1.2 Nm.</p>  <p>xx2000002007</p>  <p>xx2100000268</p>

Securing the base

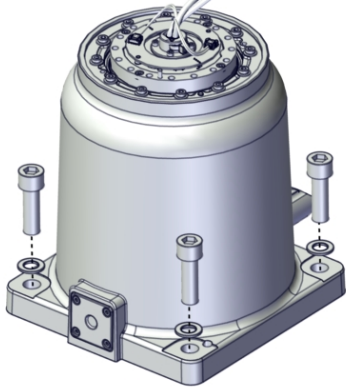
	Action	Note
1	<p>Lift the base to standing and secure it to the foundation with the attachment screws and washers.</p>	<p>Attachment screws: M10x35 8.8 (4 pcs). Washers: 23/10.5/2.5 mm Steel (4 pcs). Tightening torque: 32 Nm ±10%.</p>  <p>xx2000002006</p>





Continues on next page

5 Repair

5.3.2 Replacing the axis-1 cabling

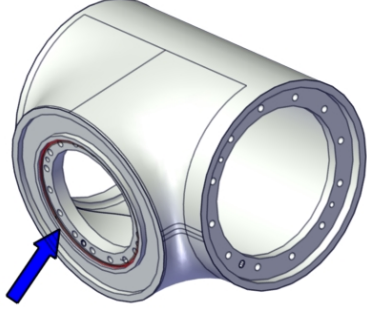

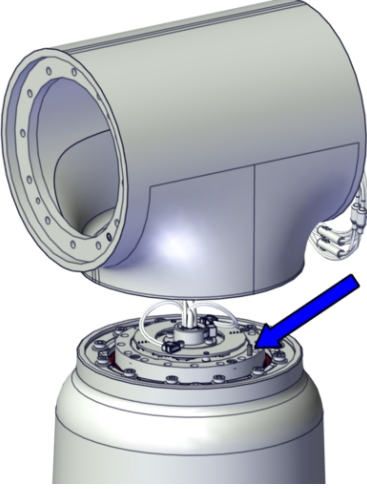
Continued

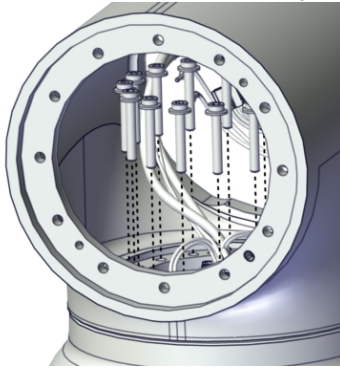
Refitting the swing(-5/0.95)



	Action	Note
1	<p>Clean the mounting surface with isopropanol. Apply flange sealant to the corner of the base mounting surface, as pointed out in the figure.</p>	<p>Cleaning agent: Isopropanol Flange sealant: Loctite 574</p>  <p>xx2000001990</p>
2	<p>Separate the new swing parts by removing the pre-assembling screws.</p>	
3	<p>Refit the swing to the base unit, aligning the pin with the pin hole.</p> <p> CAUTION</p> <p>The torque sensor (on the exposed PCBA) is sensitive to mechanical damage. Handle the assembly with care.</p>	 <p>xx2000001989</p>
4	<p>Secure the swing with the attachment screws. Pre-tighten the screws crosswise firstly.</p> <p> CAUTION</p> <p>Do not mix the flange screws used for CRB 15000-5/0.95 and the threaded screws used for CRB 15000-10/1.52 and CRB 15000-12/1.27. Always use washers together with the threaded screws for CRB 15000-10/1.52 and CRB 15000-12/1.27. Illustration is for reference only.</p>	<p>Hex socket head cap flange screw: M4x25 12.9 Lafre 2C2B/FC6.9+PrO-COat111 (16 pcs)</p>  <p>xx2000001987</p>
5	<p>Torque tighten all screws crosswise.</p>	<p>Tightening torque: 4.6 Nm</p>

Continues on next page

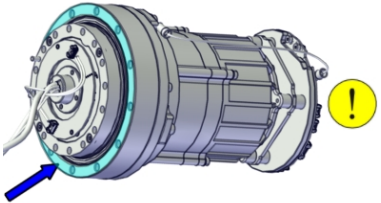
Preparations before fitting the joint unit (-5/0.95)

	Action	Note
1	 ELECTROSTATIC DISCHARGE (ESD) The unit is sensitive to ESD. Before handling the unit read the safety information in section <i>The unit is sensitive to ESD on page 53</i> .	
2	Clean the mounting surface of the joint unit and the mating surface on the casting with isopropanol. Joint unit mounting surface is pointed out in the figure.	Cleaning agent: Isopropanol Flange sealant: Loctite 574
3	Apply a thin layer of flange sealant to the mounting surface. Do not contaminate the radial sealing with sealant.  CAUTION The connectors and the joint unit cables are sensitive to mechanical damage. Handle the assembly with care.  ELECTROSTATIC DISCHARGE (ESD) The unit is sensitive to ESD. Before handling the unit read the safety information in section <i>The unit is sensitive to ESD on page 53</i> .	 xx2000001860

Refitting the axis-2 joint unit (-5/0.95)

	Action	Note
1	 ELECTROSTATIC DISCHARGE (ESD) The unit is sensitive to ESD. Before handling the unit read the safety information in section <i>The unit is sensitive to ESD on page 53</i> .	
2	Fit the lifting aid to the joint unit.  CAUTION The connectors and the joint unit cables are sensitive to mechanical damage. Handle the assembly with care.	Joint unit: 3HAC079141-001 Lifting aid: 3HAC077788-001 Screws: M4x35 (4 pcs)

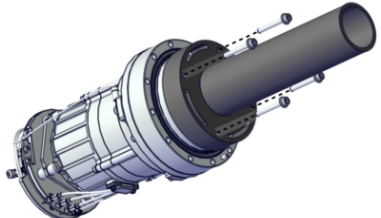







xx2000001957

Continues on next page

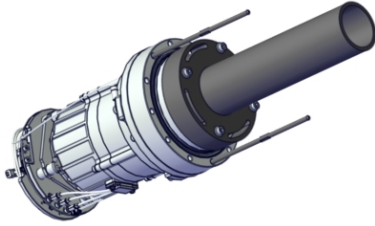
5 Repair

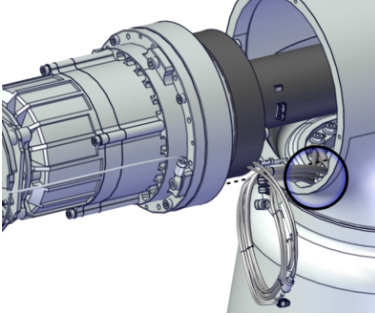
5.3.2 Replacing the axis-1 cabling

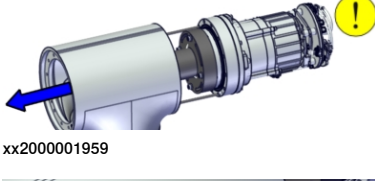
Continued

	Action	Note
3	Fit two guide pins to the joint unit.	<p>Guide pin, M4x120: 3HAC077786-001</p> <p>Always use guide pins in pairs.</p> <p>For joint units on axes 1, 2 and 3 of CRB 15000-5/0.95 and axis 3 of CRB 15000-10/1.52 and CRB 15000-12/1.27.</p>  <p>xx2000002438</p>
4	<p>Place the axis-1 cabling at the notch in the swing.</p> <p> CAUTION</p> <p>The cabling is sensitive to mechanical damage. Handle it with care to avoid damage to the cabling or the connector, avoid any kind of tilt or skew.</p>	 <p>xx2000002153</p>
5	<p>Fit the joint unit to the swing, aligning the pin with the pin hole.</p> <p> CAUTION</p> <p>The connectors and the joint unit cables are sensitive to mechanical damage. Handle the assembly with care.</p>	 <p>xx2000001959</p>  <p>xx2000001961</p>

Continues on next page

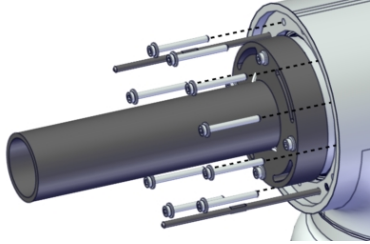
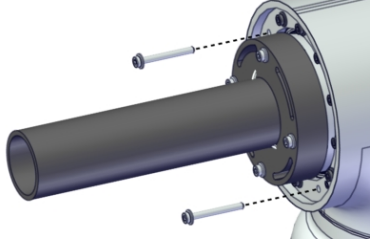
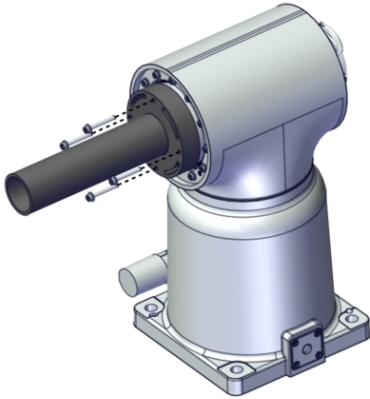
	Action	Note
6	Secure the joint unit with new attachment screws.	<p>Flange socket head screw with glue: 3HAB3413-435 M4x35 12.9 Lafre 2C2B/FC6.9+PrO-COat111, with NYPLAS glue , 12 pcs Used for joint unit of CRB 15000-5/0.95. Always use new screws when refitting a joint unit. If ordering a new joint unit spare part, new screws are included.</p>  <p>xx2000001943</p>
7	Remove the guide pins and secure the remaining two attachment screws.	 <p>xx2100000295</p>
8	Pre-tighten the screws crosswise.	
9	Torque tighten all screws crosswise.	Tightening torque: 4.3 Nm.
10	Remove the lifting aid by removing the screws.	 <p>xx2000001956</p>
11	Clean pushed-out flange sealant, if any.	



Continues on next page

5 Repair

5.3.2 Replacing the axis-1 cabling

Continued

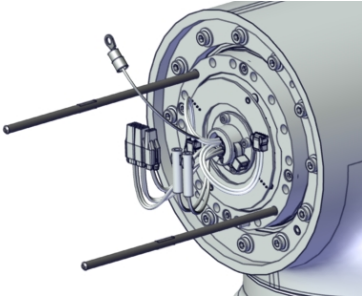
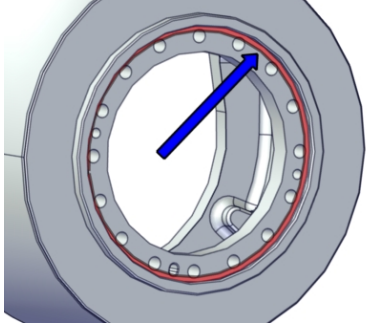
Refitting the lower and upper arm assembled (-5/0.95)

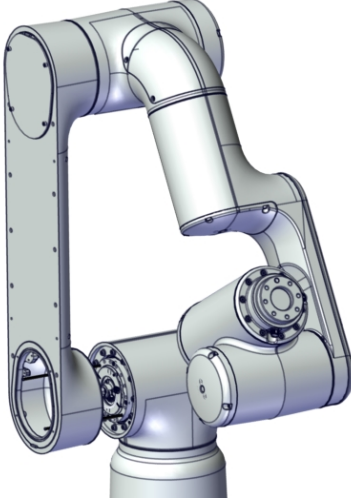
	Action	Note
1	Fit two guide pins to the axis-2 joint unit.	<p>Guide pin, M4x120: 3HAC077786-001</p>  <p>xx2000001949</p>
2	<p>Remove any old residuals of flange sealant from the lower arm mounting surface and clean with isopropanol.</p> <p>Apply new flange sealant to the corner of the lower arm mounting surface, as pointed out in the figure.</p>	<p>Cleaning agent: Isopropanol Flange sealant: Loctite 574</p>  <p>xx2000001963</p>
3	<p> CAUTION</p> <p>The weight of the complete upper and lower arm together is 18 kg</p>	
4	Lift the upper and lower arm assembly to mounting position and slide it onto the guide pins.	 <p>xx2000001941</p>

Continues on next page

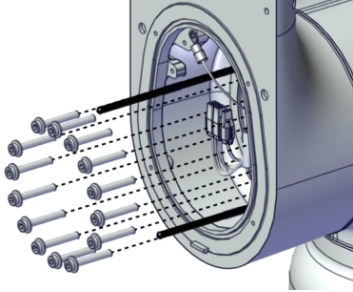
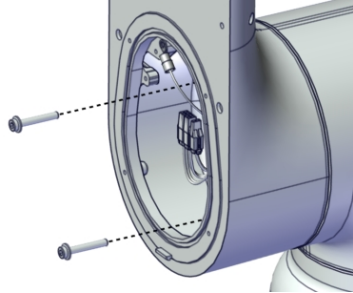
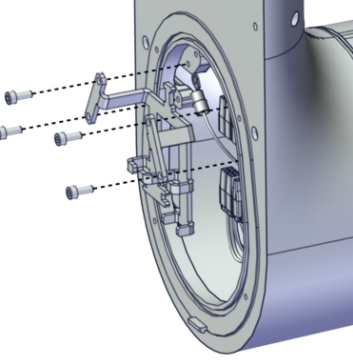
	Action	Note
5	<p>Secure the lower arm to the swing with all attachment screws but two. Pre-tighten the screws crosswise firstly.</p> <p>! CAUTION</p> <p>Do not mix the flange screws used for CRB 15000-5/0.95 and the threaded screws used for CRB 15000-10/1.52 and CRB 15000-12/1.27. Always use washers together with the threaded screws for CRB 15000-10/1.52 and CRB 15000-12/1.27. Illustration is for reference only.</p>	<p>Hex socket head cap flange screw: M4x25 12.9 Lafre 2C2B/FC6.9+PrO-COat111 (16 pcs)</p>  <p>xx2000001940</p>
6	<p>Remove the guide pins and fasten the remaining two screws.</p> <p>! CAUTION</p> <p>Do not mix the flange screws used for CRB 15000-5/0.95 and the threaded screws used for CRB 15000-10/1.52 and CRB 15000-12/1.27. Always use washers together with the threaded screws for CRB 15000-10/1.52 and CRB 15000-12/1.27. Illustration is for reference only.</p>	<p>Hex socket head cap flange screw: M4x25 12.9 Lafre 2C2B/FC6.9+PrO-COat111 (16 pcs)</p>  <p>xx2000001951</p>
7	Torque tighten all screws crosswise.	Tightening torque: 4.6 Nm
8	Refit the cable bracket with four screws.	<p>Hex socket head cap screw: M3x8 12.9 Lafre 2C2B/FC6.9 (4 pcs). Tightening torque: 0.8 Nm</p>  <p>xx2000001939</p>

Continues on next page

5 Repair

5.3.2 Replacing the axis-1 cabling

Continued

Connecting the axis-2 joint unit cabling

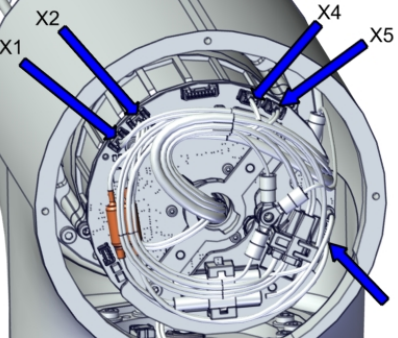
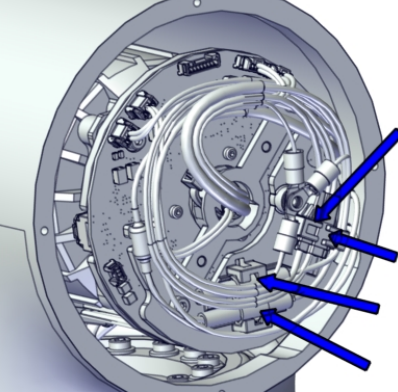
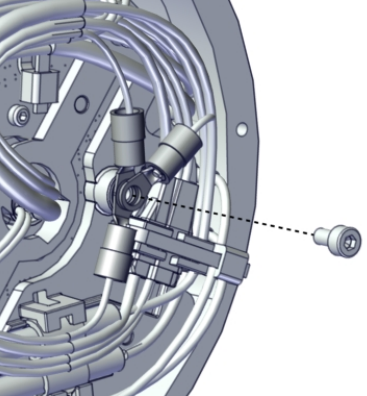
	Action	Note
1	 <p>ELECTROSTATIC DISCHARGE (ESD)</p> <p>The unit is sensitive to ESD. Before handling the unit read the safety information in section <i>The unit is sensitive to ESD on page 53.</i></p>	
2	<p>Reconnect the connectors to the drive board.</p> <ul style="list-style-type: none"> • D2.X1 to X1 • D2.DC+ to DC+ • D2.DC- to Ground • D2.X4 to X4 • D2.X2 to X2 • D2.X5 to X5 	 <p>xx2000002013</p>
3	<p>Connect the connectors to each other and snap them to the cable holders.</p> <ul style="list-style-type: none"> • J2.DC+ to J2.DC+ • J2.DC- to J2.DC- • J2.CS to J2.CS • J2.CP to J2.CP 	 <p>xx2000001944</p>
4	<p>Secure the cables for functional earth and protective earth with a screw.</p>	<p>Hex socket head cap screw: M3x6 (1 pcs).</p> <p>Tightening torque: 0.8 Nm.</p>  <p>xx2000001945</p>

Continues on next page

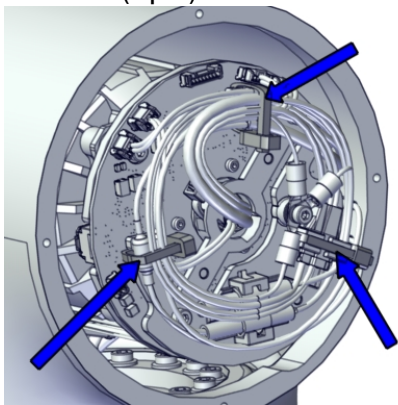
	Action	Note
5	Secure the cabling with cable ties.	Cable ties (3 pcs)  xx2000001946

Connecting the cabling between the lower arm and swing

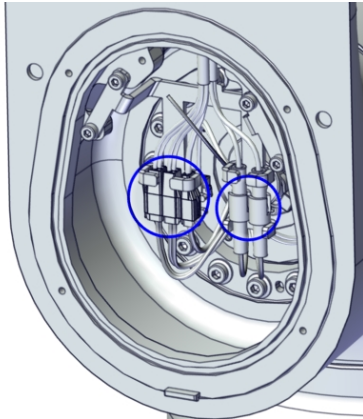
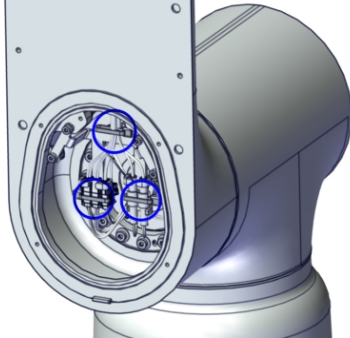
	Action	Note
1	Connect the connectors to each other and snap them to the cable holders.	 xx2000001938
2	Secure the cabling with cable ties.	Cable ties (3 pcs)  xx2000001937

Continues on next page

5 Repair

5.3.2 Replacing the axis-1 cabling

Continued

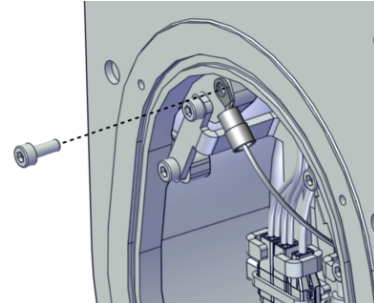
	Action	Note
3	Connect the functional earth cable with the screw.	<p>Hex socket head cap screw: M3x8 12.9 Lafre 2C2B/FC6.9 (1 pcs). Tightening torque: 0.8 Nm</p>  <p>xx2000001936</p>

Refitting the lower arm covers (-5/0.95)

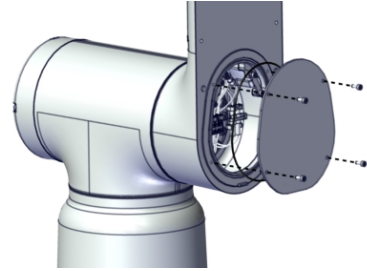
	Action	Note
1	Wipe, lubricate and fit the o-ring to its groove. Replace if damaged.	<p>O-ring: 3HAC061327-044 Grease: 3HAC042536-001 (Shell Gadus S2)</p>  <p>xx2000001954</p>
2	Refit the inner cover with four screws.	<p>Hex socket head cap screw: M3x8 12.9 Lafre 2C2B/FC6.9 (4 pcs) Tightening torque: 1.4 Nm.</p>  <p>xx2000001930</p>

Continues on next page

	Action	Note
3	Snap the lower arm cover into place.	Hex socket head cap screw: M3x16 12.9 Lafre 2C2B/FC6.9 (4 pcs) Tightening torque: 0.45 Nm.
4	Secure the cover with four screws.	

Refitting the swing cover(-5/0.95)

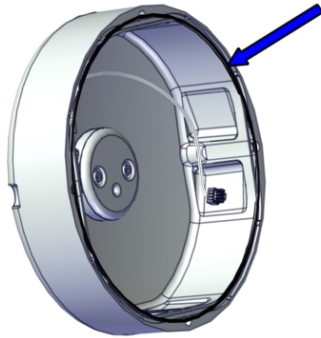
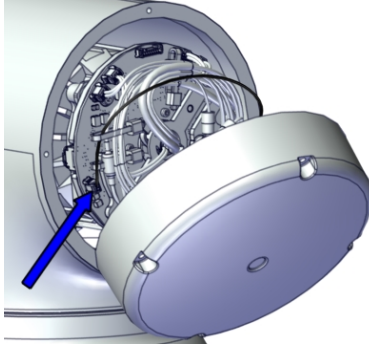
	Action	Note
1	Fit the o-ring to cover groove. Replace if damaged.	O-ring: 3HAC061327-047 (for CRB 15000-5/0.95)  xx2000001962
2	For robots with RobotWare earlier than 7.10 Place the cover at mounting position and reconnect the brake release connector DR.X8 to the drive board. Orient the cover for proper arrangement of the brake release cable.	 xx2000001932

Continues on next page

5 Repair

5.3.2 Replacing the axis-1 cabling

Continued

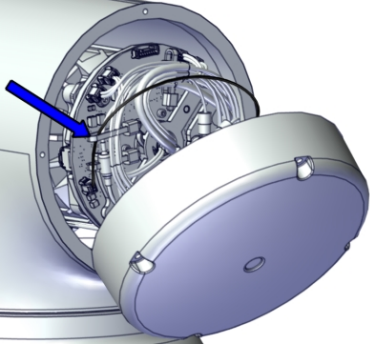
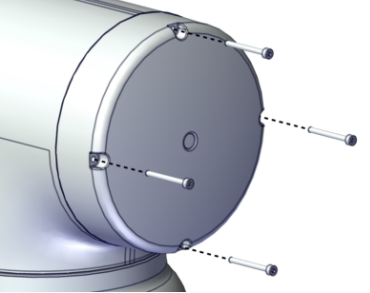
	Action	Note
3	For robots with RobotWare earlier than 7.10 Secure the brake release cable with a cable tie.	Cable ties  xx2000001931
4	Refit the cover with the four screws.	Hex socket head cap screw: M3x30 12.9 Lafre 2C2B/FC6.9 (4 pcs) Tightening torque: 0.45 Nm  xx2000001935

Continues on next page



Concluding procedure

	Action	Note
1	<p>Calibrate the joint unit torque sensor.</p> <ol style="list-style-type: none"> 1 On the FlexPendant, go to the Code app and call the calibration procedure using PP to Routine, not by using Call Routine. 2 Select the Joint Unit Replacement feature and then select the axis to calibrate. 3 The controller is now restarted. Once the home screen of the FlexPendant is shown, press the Play button to continue the calibration routine. 4 The robot moves to a position or positions where measurements are performed. 5 The results of the measurements are presented together with the current values in the controller. Choose whether to save the calibration data or not. 6 If new calibration data is saved you will be asked to do a test with the lead-through functionality active to verify that the sensors work correctly. 7 Finally the robot is moved back to the original position. 8 Test the brake release (movement without drive power) functionality, see Testing the brake release functionality on page 196. 	See Calibration on page 1063
2	 DANGER <p>Make sure all safety requirements are met when performing the first test run. See Test run after installation, maintenance, or repair on page 90.</p>	

Refitting the joint cabling (-10/1.52 and -12/1.27)

Use these procedures to refit the joint-1 cabling.

Refitting the joint cable

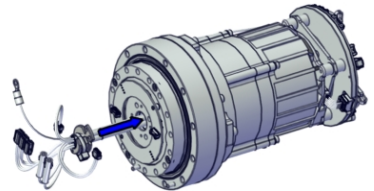
	Action	Note
1	 ELECTROSTATIC DISCHARGE (ESD) <p>The unit is sensitive to ESD. Before handling the unit read the safety information in section The unit is sensitive to ESD on page 53.</p>	
2	<p>Place the joint cable through the hollow shaft from the torque sensor side.</p>  CAUTION <p>The connectors and the joint unit cables are sensitive to mechanical damage. Handle the assembly with care.</p>	 <p>xx2000002048</p>

Continues on next page

5 Repair

5.3.2 Replacing the axis-1 cabling

Continued

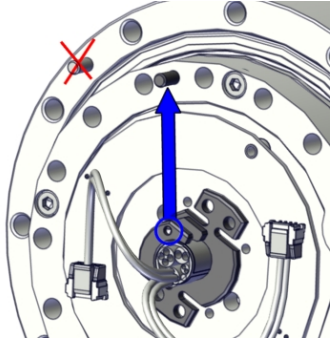
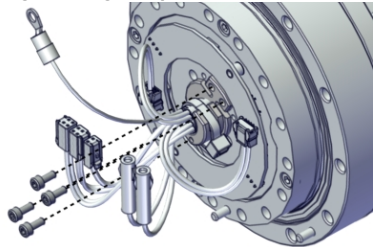
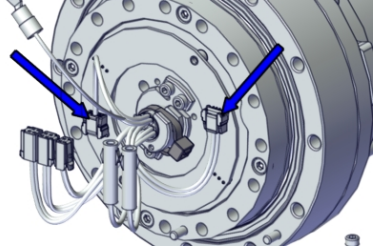
	Action	Note
3	Orient the cable plate according to the figure. The circle on the cable plate should point towards the guide pin on the torque sensor.	 xx2000002051
4	Secure the cable plate to the joint unit with the attachment screws.	Hex socket head cap screw: M2.5x6 12.9 Lafre 2C2B/FC6.9 (4 pcs) Tightening torque: 0.45 Nm.  xx2000002049
5	Connect the two connectors to the torque sensor board. <ul style="list-style-type: none">• TQ.A to CH1/A• TQ.B to CH2/B	 xx2000002053

Continues on next page

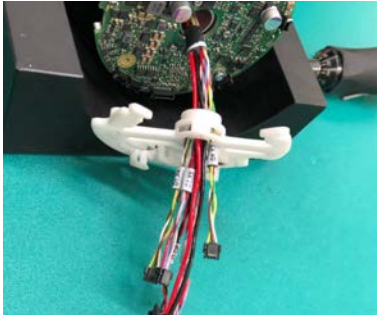
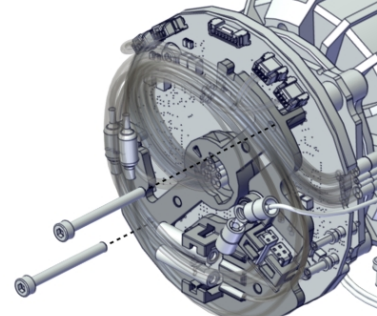
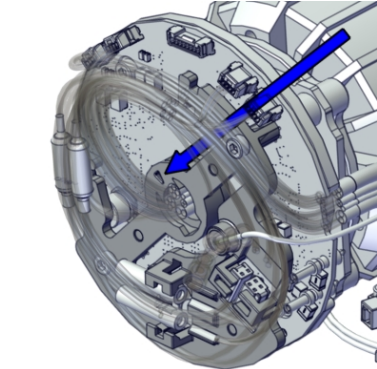

	Action	Note
6	<p>Insert the cabling through the cable support and fit the support to the drive board with the attachment screws.</p>	 <p>xx2000002056</p> <p>Hex socket head cap screw: M3x30 12.9 Lafre 2C2B/FC6.9 (2 pcs) Tightening torque: 0.45 Nm.</p>  <p>xx2000002055</p>
7	<p>Keep the cabling loose, making sure not to twist or strain it. Use the cable tie to pre-fix the cable by hand.</p>	 <p>xx2100000507</p>

Continues on next page

5 Repair

5.3.2 Replacing the axis-1 cabling

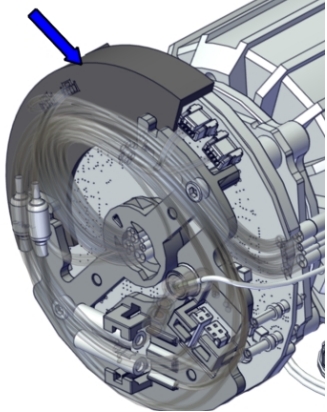
Continued

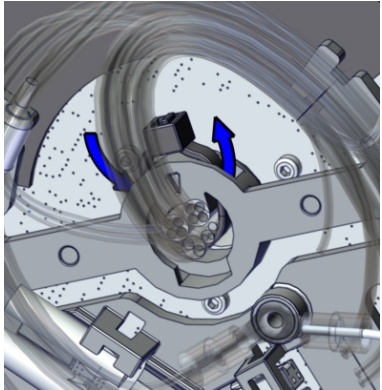
	Action	Note
8	Fit the protection plate to the drive board unit.	<p>Protection plate: 3HAC077790-001 (for CRB 15000-5/0.95) / 3HAC087789-001 (for CRB 15000-10/1.52 and CRB 15000-12/1.27)</p>  <p>xx2000002057</p>
9	Secure the cables to the cable support with a cable tie, using a cable tie gun. Assembly direction for the cable tie is shown in the figure.	<p>Cable tie: 3HAC075545-001. For securing joint unit cable. Cable tie gun EVO 7i Setting for cable tie gun: 6.75.</p>  <p>xx2000002058</p>  <p>xx2000002059</p>

Continues on next page

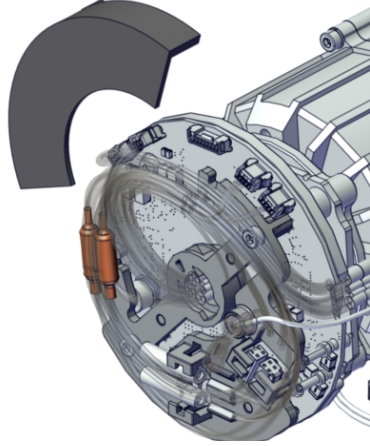
	Action	Note
10	Remove the protection plate.	 <p data-bbox="1058 768 1166 786">xx210000301</p>

Connecting the axis-1 joint unit cabling

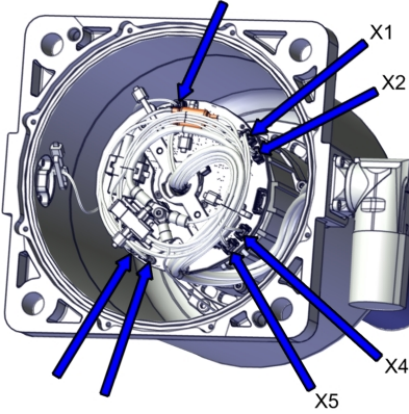
	Action	Note
1	 <p data-bbox="596 969 1011 1003">ELECTROSTATIC DISCHARGE (ESD)</p> <p data-bbox="507 1034 1011 1117">The unit is sensitive to ESD. Before handling the unit read the safety information in section The unit is sensitive to ESD on page 53.</p>	
2	<p data-bbox="507 1151 1011 1178">Reconnect the connectors to the drive board.</p> <ul data-bbox="544 1180 783 1406" style="list-style-type: none"> • D1.X1 to X1 • D1.DC+ to DC+ • D1.DC- to Ground • D1.X4 to X4 • D1.X2 to X2 • D1.X5 to X5 • DR.X8 to X8 	 <p data-bbox="1023 1570 1134 1588">xx2000002009</p>

Continues on next page

5 Repair

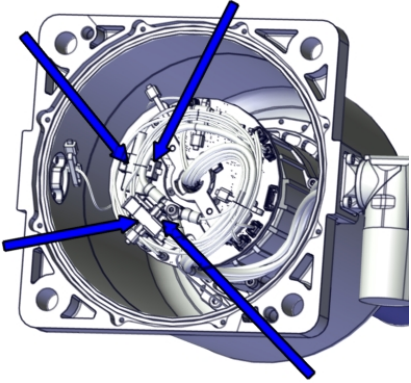
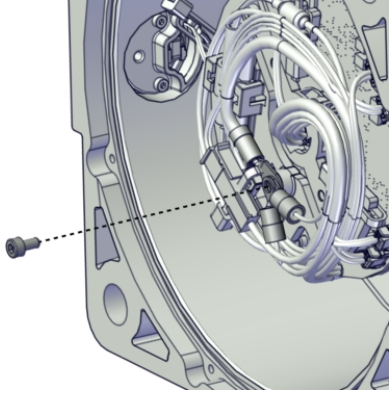
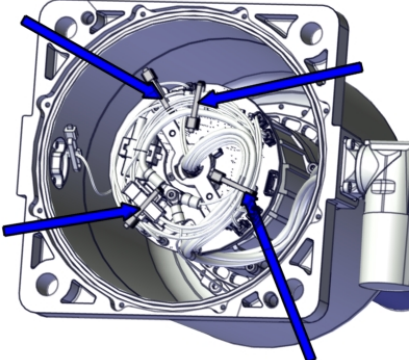

5.3.2 Replacing the axis-1 cabling

Continued

	Action	Note
3	<p>Connect the connectors to each other and snap them to the cable holders.</p> <ul style="list-style-type: none">• J1.DC+ to J1.DC+• J1.DC- to J1.DC-• J1.CS to J1.CS• J1.CP to J1.CP	 <p>xx2000002010</p>
4	<p>Secure the cables for functional earth and protective earth with a screw.</p>	<p>Hex socket head cap screw: M3x6 (1 pcs). Tightening torque: 0.8 Nm.</p>  <p>xx2000002011</p>
5	<p>Secure the cabling with cable ties.</p>	<p>Cable ties (4 pcs)</p>  <p>xx2000002012</p>

Continues on next page

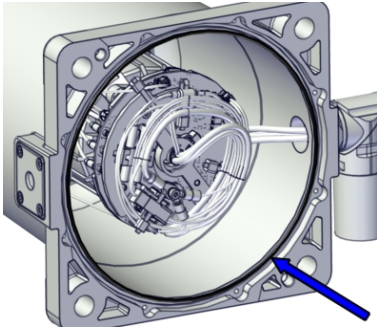
Refitting the base cover (-10/1.52 and -12/1.27)

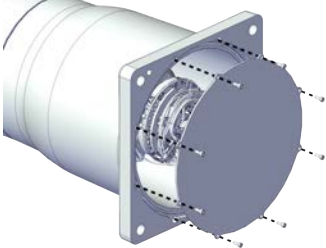
	Action	Note
1	Wipe, lubricate and fit the o-ring to its groove. Replace if damaged.	3HAC061327-072 Grease: 3HAC042536-001 (Shell Gadus S2)  xx2000002016
2	Refit the bottom cover with the attachment screws.  Note For CRB 15000-5/0.95, fit the cover in correct direction, the protrusion of the cover must face outwards.	Hex socket head cap screw: M3x8 12.9 Lafre 2C2B/FC6.9 (8 pcs) Tightening torque: 1.4 Nm.  xx2300000760

Securing the base

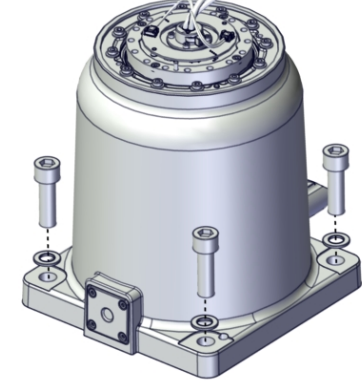
	Action	Note
1	Lift the base to standing and secure it to the foundation with the attachment screws and washers.	Attachment screws: M10x35 8.8 (4 pcs). Washers: 23/10.5/2.5 mm Steel (4 pcs). Tightening torque: 32 Nm ±10%.  xx2000002006

Continues on next page

5 Repair

5.3.2 Replacing the axis-1 cabling

Continued

Refitting the swing(-10/1.52 and -12/1.27)

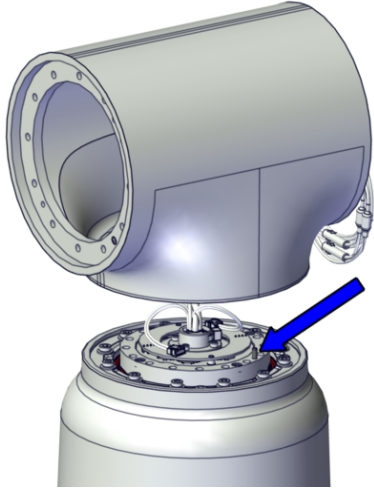
	Action	Note
1	Fit two guide pins on the base unit for position guidance. Always use guide pins in pairs.	Valid for CRB 15000-10/1.52 Guide pin, M5x75, 3HAC087786-002 Valid for CRB 15000-12/1.27 Guide pin, M5x125: 3HAC087786-001
2	Refit the swing to the base unit, aligning the pin with the pin hole.  CAUTION The torque sensor (on the exposed PCBA) is sensitive to mechanical damage. Handle the assembly with care.	Example of CRB 15000-12/1.27, similar to CRB 15000-10/1.52.  xx2000001989

Continues on next page



	Action	Note
3	<p>Secure the swing with the attachment screws.</p> <p> CAUTION</p> <p>Do not mix the flange screws used for CRB 15000-5/0.95 and the threaded screws used for CRB 15000-10/1.52 and CRB 15000-12/1.27. Always use washers together with the threaded screws for CRB 15000-10/1.52 and CRB 15000-12/1.27. Illustration is for reference only.</p>	<p>Hex socket head cap screw: M5x30 12.9 Lafre 2C2B/FC6.9 (16 pcs) Tightening torque: 8.2 Nm Valid for CRB 15000-12/1.27</p>  <p>xx2000001987</p> <p>Valid for CRB 15000-10/1.52</p>  <p>xx2300000819</p>
4	<p>Valid for CRB 15000-10/1.52</p> <p>Check the o-rings on both side of the swing flange. Replace if damaged.</p>	<p>O-ring: 3HAC061327-073 O-ring: 3HAC061327-044</p>  <p>xx2300000821</p>
5	<p>Valid for CRB 15000-10/1.52</p> <p>Refit the swing flange with the attachment screws. Always check the serial number printed on the swing parts and use the parts in the same number for refitting.</p> <p> CAUTION</p> <p>Do not use the pre-assembling screws of swing parts for securing.</p>	<p>Hex socket head cap screw: M5x25 12.9 Lafre 2C2B/FC6.9 (16 pcs) Tightening torque: 8.2 Nm</p>  <p>xx2300000818</p>

Continues on next page

5 Repair

5.3.2 Replacing the axis-1 cabling

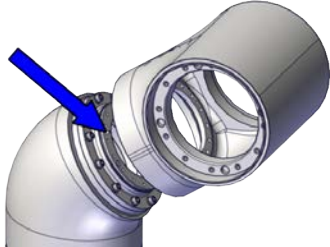

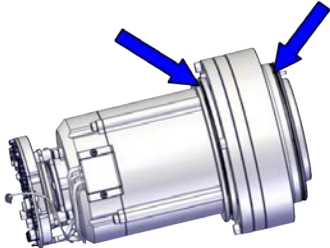

Continued

	Action	Note
6	<p>Valid for CRB 15000-10/1.52</p> <p>Fit two guide pins on the swing flange for position guidance.</p> <p>Always use guide pins in pairs.</p>	<p>Guide pin, M5x75, 3HAC087786-002</p>
7	<p>Valid for CRB 15000-10/1.52</p> <p>Refit the swing transition to the swing flange, aligning the pin with the pin hole.</p> <p>Always check the serial number printed on the swing parts and use the parts in the same number for refitting.</p>	 <p>xx2300000820</p>
8	<p>Valid for CRB 15000-10/1.52</p> <p>Secure the swing transition with the attachment screws.</p> <p> CAUTION</p> <p>Do not use the pre-assembling screws of swing parts for securing.</p>	<p>Hex socket head cap screw: M5x25 12.9 Lafre 2C2B/FC6.9 (16 pcs)</p> <p>Tightening torque: 8.2 Nm</p>  <p>xx2300000817</p>

Refitting the axis-2 joint unit (-10/1.52 and -12/1.27)

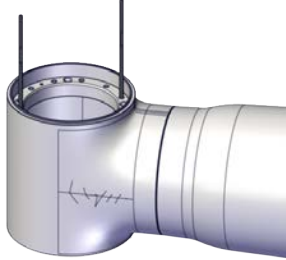
	Action	Note
1	<p> ELECTROSTATIC DISCHARGE (ESD)</p> <p>The unit is sensitive to ESD. Before handling the unit read the safety information in section The unit is sensitive to ESD on page 53.</p>	
2	<p>Check the o-rings.</p> <p>Replace if damaged.</p>	<p>O-ring: 3HAC061327-044</p>  <p>xx2300000823</p>

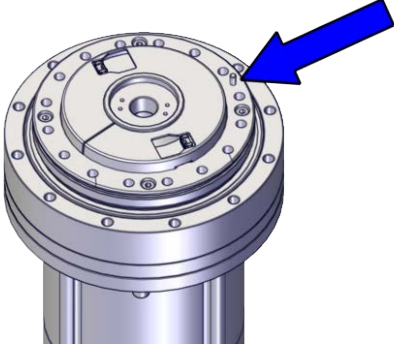
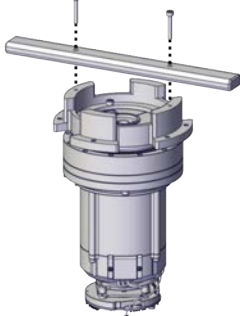
Continues on next page

	Action	Note
3	Fit two guide pins to the swing.	Guide pin, M5x125: 3HAC087786-001 Always use guide pins in pairs. For joint units on axes 1 and 2 of CRB 15000-10/1.52 and CRB 15000-12/1.27.  xx2300000791
4	Fit the lifting aid to the joint unit, aligning the pin with the pin hole.  CAUTION The connectors and the joint unit cables are sensitive to mechanical damage. Handle the assembly with care.  xx2300000777	Joint unit: 3HAC087472-001 Lifting aid: 3HAC087787-001 Screws: M5x30 (4 pcs for plate and 2 pcs for beam)  xx2300000778  xx2300000776
5	Place the axis-1 cabling properly to avoid squeezing by the joint unit when putting the joint unit into the swing.  CAUTION The cabling is sensitive to mechanical damage. Handle it with care to avoid damage to the cabling or the connector, avoid any kind of tilt or skew.	

Continues on next page

5 Repair

5.3.2 Replacing the axis-1 cabling

Continued

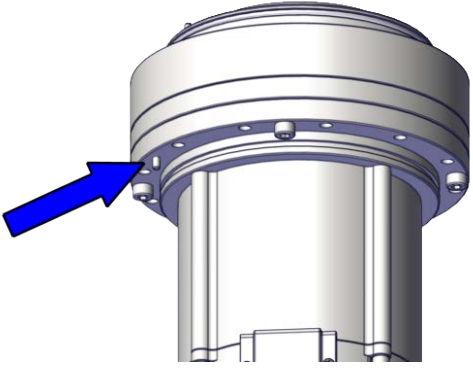
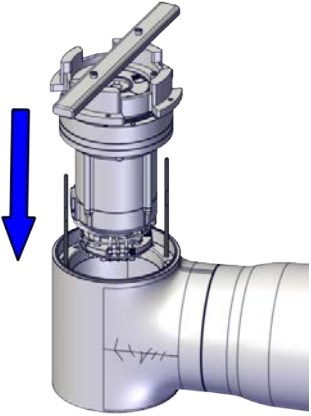
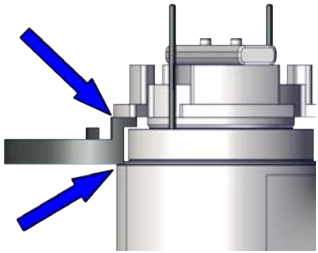
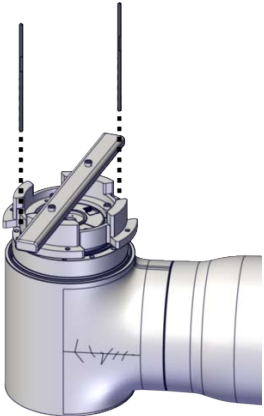
	Action	Note
6	<p>Fit the joint unit to the swing, aligning the pin with the pin hole.</p> <p> CAUTION</p> <p>The connectors and the joint unit cables are sensitive to mechanical damage. Handle the assembly with care.</p>  <p>xx2300000780</p>	 <p>xx2300000792</p>
7	<p>Check the joint unit position by placing the higher boss of one semicircular block between the lifting aid and swing.</p> <p>The joint unit is properly placed when no gaps between the block and both lifting aid and swing.</p>	 <p>xx2300000794</p>
8	<p>Remove the guide pins.</p>	 <p>xx2300000795</p>

Continues on next page

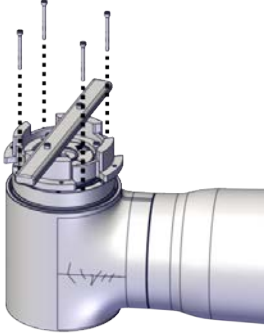
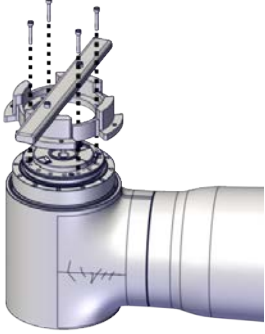
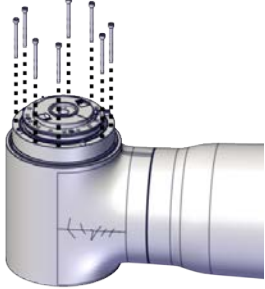
	Action	Note
9	Secure with four attachment screws and pre-tighten the screws crosswise.	 <p>xx2300000796</p>
10	Remove the lifting aid by removing the screws.	 <p>xx2300000797</p>
11	Secure the joint unit with the remaining attachment screws.	<p>Hex socket head cap screw: 3HAB3409-20</p>  <p>xx2300000798</p>
12	Torque tighten all screws crosswise.	<p>M5x55 12.9 Lafre 2C2B/FC6.9, 12 pcs Tightening torque: 8.2 Nm.</p>

Continues on next page

5 Repair



5.3.2 Replacing the axis-1 cabling

Continued

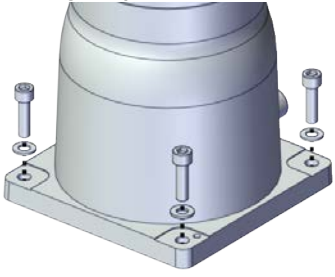

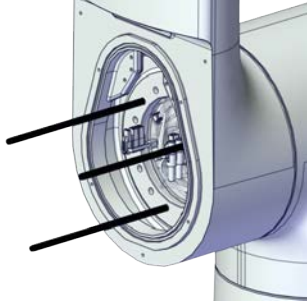

Securing the base (-10/1.52 and -12/1.27)

	Action	Note
1	Lift the base to standing and secure it to the foundation with the attachment screws and washers.	<p>Attachment screws: M10x35 8.8 (4 pcs). Washers: 23/10.5/2.5 mm Steel (4 pcs). Tightening torque: 32 Nm \pm10%.</p>  <p>xx2300001060</p>

Refitting the lower and upper arm assembled (-10/1.52 and -12/1.27)

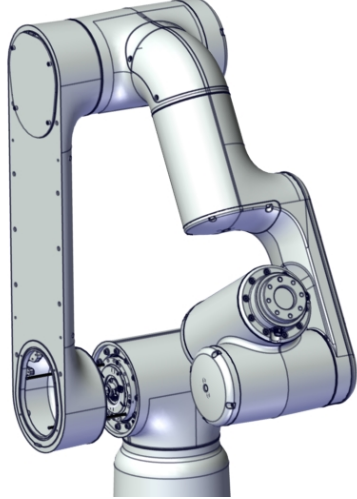
	Action	Note
1	Fit three guide pins to the axis-2 joint unit.	<p>Guide pin, M5x125: 3HAC087786-001</p>  <p>xx2300001021</p>
2	<p> CAUTION</p> <p>The weight of the complete upper and lower arm together is up to 26 kg</p>	

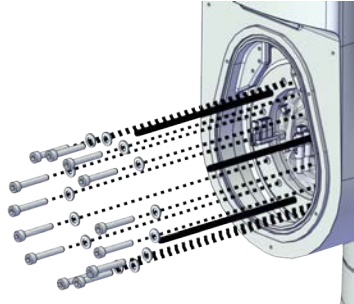
Continues on next page

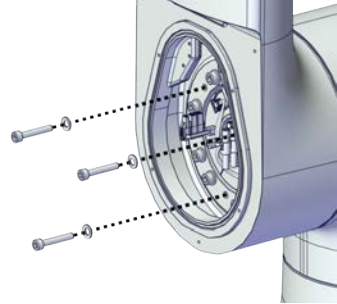
	Action	Note
3	Lift the upper and lower arm assembly to mounting position and slide it onto the guide pins.	<p>Example of CRB 15000-5/0.95, similar to CRB 15000-10/1.52 and CRB 15000-12/1.27.</p>  <p>xx2000001941</p>
4	<p>Secure the lower arm to the swing with all screws and washers but two. Pre-tighten the screws crosswise firstly.</p> <p> CAUTION</p> <p>Do not mix the flange screws used for CRB 15000-5/0.95 and the threaded screws used for CRB 15000-10/1.52 and CRB 15000-12/1.27. Always use washers together with the threaded screws for CRB 15000-10/1.52 and CRB 15000-12/1.27. Illustration is for reference only.</p>	<p>Hex socket head cap screw: M5x30 12.9 Lafre 2C2B/FC6.9, 16 pcs</p>  <p>xx2300001022</p>
5	<p>Remove the guide pins and fasten the remaining two screws and washers.</p> <p> CAUTION</p> <p>Do not mix the flange screws used for CRB 15000-5/0.95 and the threaded screws used for CRB 15000-10/1.52 and CRB 15000-12/1.27. Always use washers together with the threaded screws for CRB 15000-10/1.52 and CRB 15000-12/1.27. Illustration is for reference only.</p>	<p>Hex socket head cap screw: M5x30 12.9 Lafre 2C2B/FC6.9, 16 pcs</p>  <p>xx2300001023</p>
6	Torque tighten all screws crosswise.	Tightening torque: 8.2 Nm

Continues on next page

5 Repair

5.3.2 Replacing the axis-1 cabling

Continued

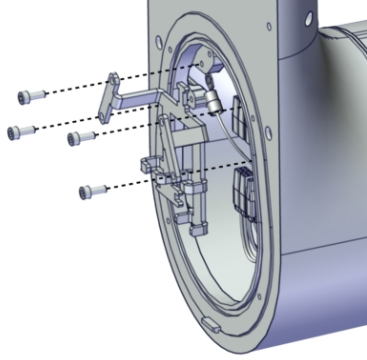
	Action	Note
7	Refit the cable bracket with four screws.	<p>Hex socket head cap screw: M3x8 12.9 Lafre 2C2B/FC6.9 (4 pcs). Tightening torque: 0.8 Nm</p>  <p>xx2000001939</p>

Connecting the axis-2 joint unit cabling

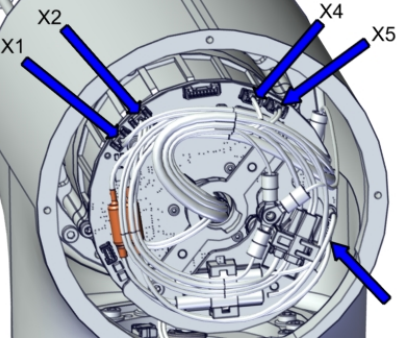
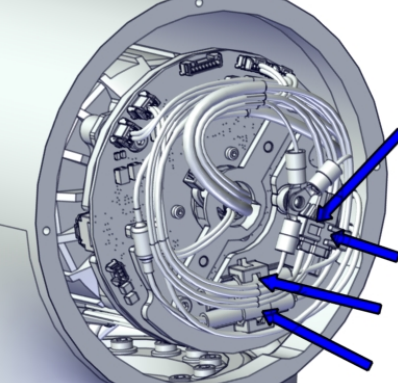
	Action	Note
1	 <p>ELECTROSTATIC DISCHARGE (ESD)</p> <p>The unit is sensitive to ESD. Before handling the unit read the safety information in section The unit is sensitive to ESD on page 53.</p>	
2	<p>Reconnect the connectors to the drive board.</p> <ul style="list-style-type: none"> • D2.X1 to X1 • D2.DC+ to DC+ • D2.DC- to Ground • D2.X4 to X4 • D2.X2 to X2 • D2.X5 to X5 	 <p>xx2000002013</p>
3	<p>Connect the connectors to each other and snap them to the cable holders.</p> <ul style="list-style-type: none"> • J2.DC+ to J2.DC+ • J2.DC- to J2.DC- • J2.CS to J2.CS • J2.CP to J2.CP 	 <p>xx2000001944</p>

Continues on next page

5.3.2 Replacing the axis-1 cabling
Continued

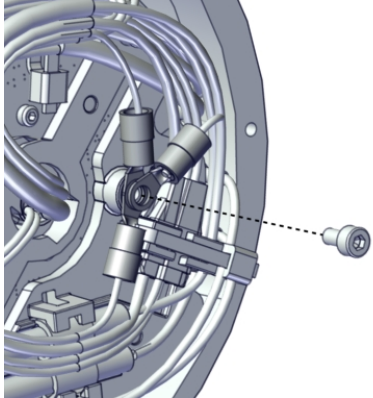
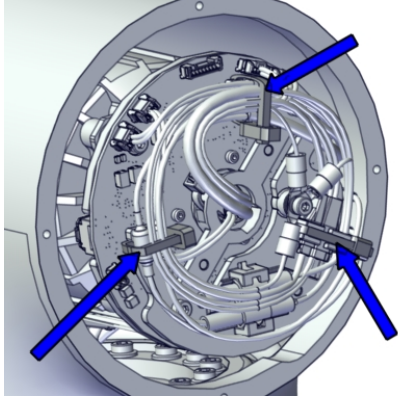
	Action	Note
4	Secure the cables for functional earth and protective earth with a screw.	<p>Hex socket head cap screw: M3x6 (1 pcs). Tightening torque: 0.8 Nm.</p>  <p>xx2000001945</p>
5	Secure the cabling with cable ties.	<p>Cable ties (3 pcs)</p>  <p>xx2000001946</p>

Connecting the cabling between the lower arm and swing

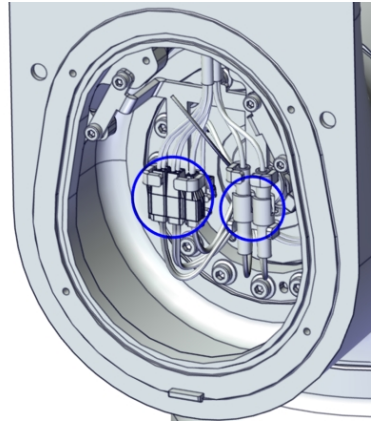
	Action	Note
1	Connect the connectors to each other and snap them to the cable holders.	 <p>xx2000001938</p>

Continues on next page

5 Repair

5.3.2 Replacing the axis-1 cabling

Continued

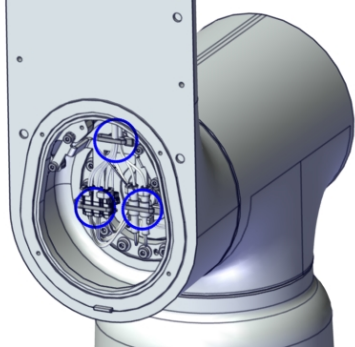
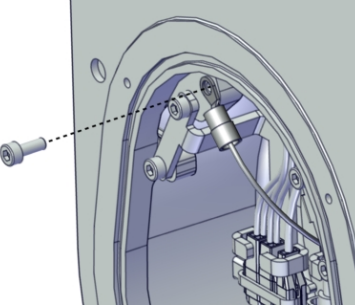
	Action	Note
2	Secure the cabling with cable ties.	<p>Cable ties (3 pcs)</p>  <p>xx2000001937</p>
3	Connect the functional earth cable with the screw.	<p>Hex socket head cap screw: M3x8 12.9 Lafre 2C2B/FC6.9 (1 pcs). Tightening torque: 0.8 Nm</p>  <p>xx2000001936</p>

Removing the lower arm covers (-10/1.52 and -12/1.27)

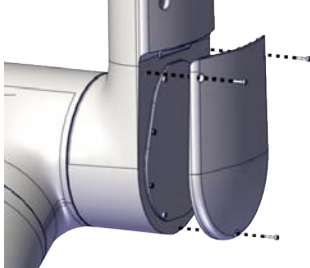
	Action	Note
1	 CAUTION Make sure that all supplies for electrical power are turned off.	
2	Remove the lower cover of lower arm by removing the screws.	 <p>xx2300000812</p>

Continues on next page

5.3.2 Replacing the axis-1 cabling
Continued

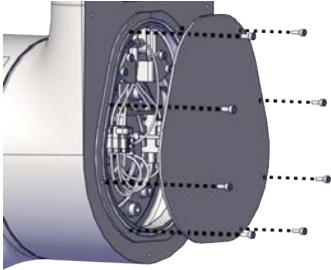
	Action	Note
3	Remove the lower inner cover by removing the screws.	 <p>xx2300000813</p>

Refitting the swing cover and insert(-10/1.52 and -12/1.27)

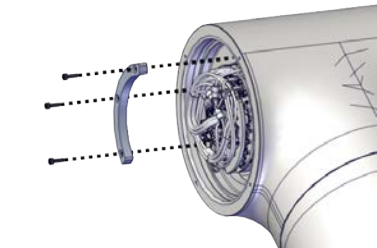
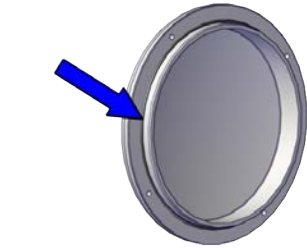
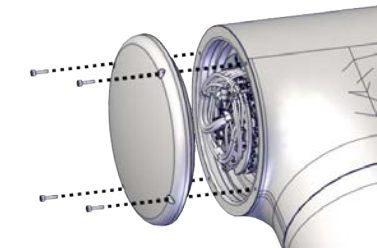
	Action	Note
1	Refit the insert.	<p>Insert: 3HAC084002-001 Hex socket head cap screw: M3x10 12.9 Lafre 2C2B/FC6.9 (3 pcs) Tightening torque: 1.4 Nm</p>  <p>xx2300000815</p>
2	Fit the o-ring to cover groove. Replace if damaged.	<p>O-ring: 3HAC061327-074 (for CRB 15000-10/1.52 and CRB 15000-12/1.27)</p>  <p>xx2300000816</p>
3	Refit the cover with the four screws.	<p>Hex socket head cap screw: M3x12 12.9 Lafre 2C2B/FC6.9 (4 pcs) Tightening torque: 1.4 Nm</p>  <p>xx2300000814</p>

Continues on next page

5 Repair

5.3.2 Replacing the axis-1 cabling

Continued

Concluding procedure

	Action	Note
1	<p>Calibrate the joint unit torque sensor.</p> <ol style="list-style-type: none">1 On the FlexPendant, go to the Code app and call the calibration procedure using PP to Routine, not by using Call Routine.2 Select the Joint Unit Replacement feature and then select the axis to calibrate.3 The controller is now restarted. Once the home screen of the FlexPendant is shown, press the Play button to continue the calibration routine.4 The robot moves to a position or positions where measurements are performed.5 The results of the measurements are presented together with the current values in the controller. Choose whether to save the calibration data or not.6 If new calibration data is saved you will be asked to do a test with the lead-through functionality active to verify that the sensors work correctly.7 Finally the robot is moved back to the original position.8 Test the brake release (movement without drive power) functionality, see Testing the brake release functionality on page 196.	See Calibration on page 1063
2	<p> DANGER</p> <p>Make sure all safety requirements are met when performing the first test run. See Test run after installation, maintenance, or repair on page 90.</p>	

5.3.3 Replacing the axis-2 cabling

Location of the cable harness

The cable harness is located as shown in the figure.



xx210000058

Summary of the replacement procedure

This is a brief summary of the replacement procedure, containing the major actions to be performed.

- 1 Separate the cabling between the swing and the lower arm.
- 2 Remove the lower and upper arm undivided.
- 3 Remove the swing cover.
- 4 Remove the axis-2 joint unit.
- 5 Replace the cabling.

Required spare parts



Note

The spare part numbers that are listed in the table can be out of date. See the latest spare parts of the CRB 15000 via myABB Business Portal, www.abb.com/myABB.

Continues on next page

5 Repair

5.3.3 Replacing the axis-2 cabling

Continued

Spare part	Article number	Note
Cable harness, joint 2	3HAC073205-001	Used for CRB 15000-5/0.95. Also order new Cable tie: 3HAC075545-001.
Cable harness, joint 2	3HAC080960-001	Used for CRB 15000-10/1.52 and CRB 15000-12/1.27. Also order new Cable tie: 3HAC075545-001.
Cable tie	3HAC075545-001	For securing joint unit cable.

Required tools and equipment

Equipment	Article number	Note
Lifting aid	3HAC077788-001	For joint units on axes 1, 2 and 3 of CRB 15000-5/0.95. Attachment screws M4x35 (4 pcs) are enclosed.
Lifting aid	3HAC087787-001	For joint units on axes 1 and 2 of CRB 15000-10/1.52 and CRB 15000-12/1.27. A plate, a beam, a pair of semicir- cular blocks and attachment screws M5x30 (2 pcs) are en- closed.
Guide pin, M4x120	3HAC077786-001	Always use guide pins in pairs. For joint units on axes 1, 2 and 3 of CRB 15000-5/0.95 and axis 3 of CRB 15000-10/1.52 and CRB 15000-12/1.27.
Guide pin, M5x125	3HAC087786-001	Always use guide pins in pairs. For joint units on axes 1 and 2 of CRB 15000-10/1.52 and CRB 15000-12/1.27.
Protection plate	3HAC077790-001	For protection of drive board during cabling installation on joint units of CRB 15000-5/0.95.
Protection plate	3HAC087789-001	For protection of drive board during cabling installation on joint units of CRB 15000-10/1.52 and CRB 15000-12/1.27.
Cable tie gun EVO 7i	-	HellermannTyton 110-77001 or similar
Standard toolkit	-	Content is defined in section Standard toolkit on page 1099 .

Required consumables

Consumable	Article number	Note
Cable ties	-	
O-ring	3HAC061327-044	Lower arm, inner cover of CRB 15000-5/0.95. 1 pcs / cover. Replace if damaged.



Continues on next page

Consumable	Article number	Note
O-ring	3HAC061327-075	Lower arm, lower inner cover of CRB 15000-10/1.52 and CRB 15000-12/1.27. Replace if damaged.
O-ring	3HAC061327-047	Cover for axis 2/3, used for CRB 15000-5/0.95. Replace if damaged.
O-ring	3HAC061327-074	Swing cover, used for CRB 15000-10/1.52 and CRB 15000-12/1.27. Replace if damaged.
O-ring	3HAB3772-64	Base cover, used for CRB 15000-5/0.95.
O-ring	3HAC061327-072	Base cover, used for CRB 15000-10/1.52 and CRB 15000-12/1.27.
Cleaning agent	-	Isopropanol
Flange sealant	-	Loctite 574
Grease	3HAC042536-001	Shell Gadus S2

Removing the joint cabling (-5/0.95)

Use these procedures to remove the joint-2 cabling.

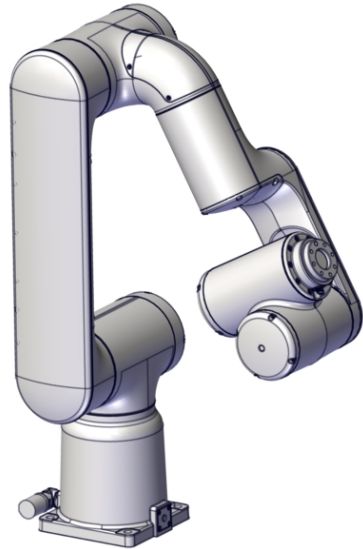
Preparations before removing the cabling

	Action	Note
1	<p>Jog the robot to the specified position:</p> <ul style="list-style-type: none"> • Axis 1: 0° • Axis 2: 0° (home position) • Axis 3: +60° • Axis 4: 0° • Axis 5: -90° • Axis 6: No significance. <p> CAUTION</p> <p>Jog the axis on which the joint unit is to be replaced to home position, to achieve correct cable routing during replacement of the joint unit.</p>	 <p>xx2100000044</p>
2	<p> CAUTION</p> <p>Turn off all supplies for electrical power to the robot, before starting the repair work.</p>	

Continues on next page

5 Repair

5.3.3 Replacing the axis-2 cabling

Continued

Removing the lower arm covers (-5/0.95)

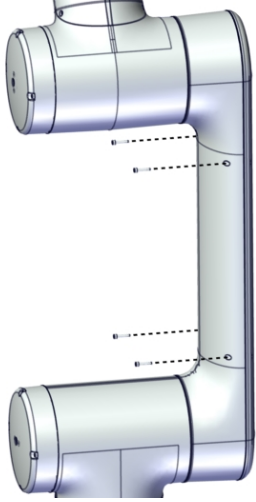
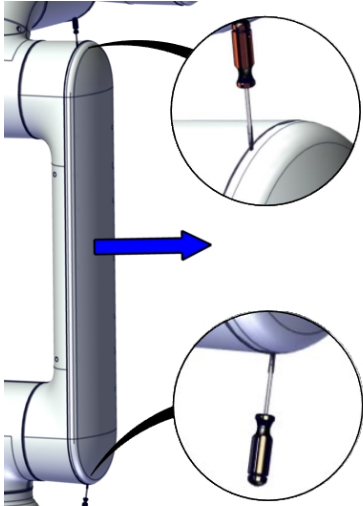
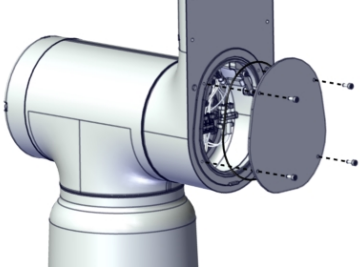
	Action	Note
1	 CAUTION Make sure that all supplies for electrical power are turned off.	
2	Remove the four lower arm cover screws.	 xx2000001929
3	Remove the cover by inserting a small flat screwdriver to snap open the locks at each end of the cover.	 xx2100000267
4	Remove the inner cover by removing the four screws.	 xx2000001930

Continues on next page

Disconnecting the cabling between the lower arm and the swing

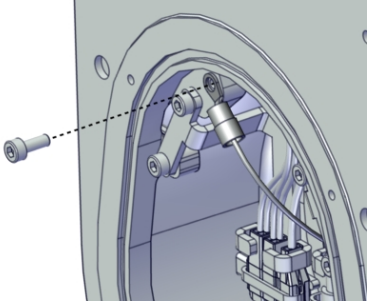
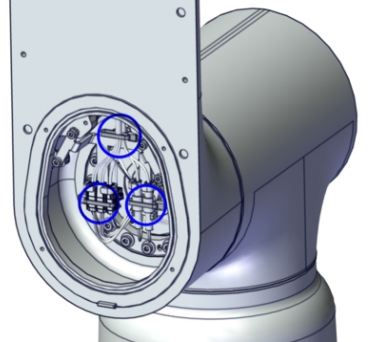
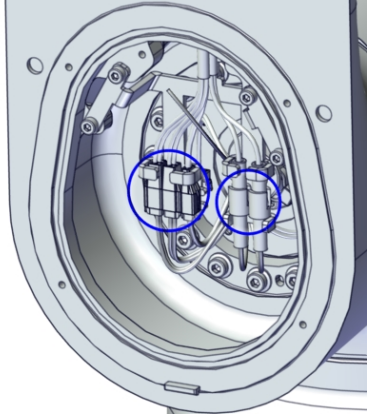
	Action	Note
1	Remove the functional earth cable by removing the screw.	 <p>xx2000001936</p>
2	Cut the cable ties.	 <p>xx2000001937</p>
3	Snap loose and disconnect all connectors.	 <p>xx2000001938</p>



Continues on next page

5 Repair

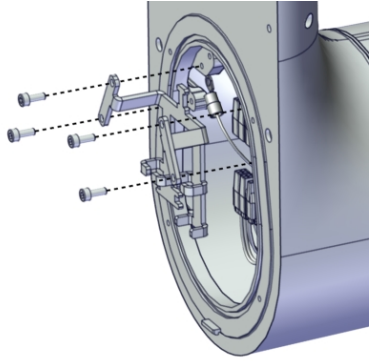

5.3.3 Replacing the axis-2 cabling

Continued

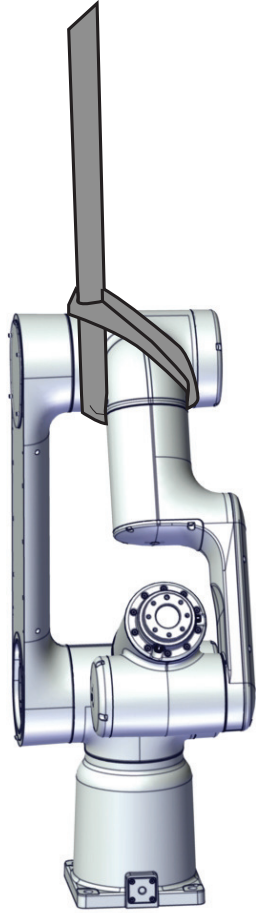
Removing the lower and upper arm assembled

	Action	Note
1	Remove the cable bracket by removing the four screws.	 xx2000001939
2	Secure the weight of the upper and lower arm.  CAUTION The weight of the complete upper and lower arm together is 18 kg	Suggestion with lifting sling and an overhead crane. Example of CRB 15000-5/0.95, similar to CRB 15000-10/1.52 and CRB 15000-12/1.27.  xx2100000294

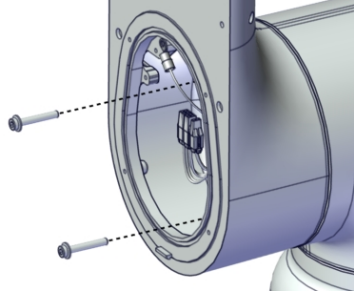
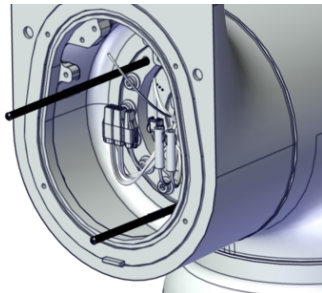
Continues on next page

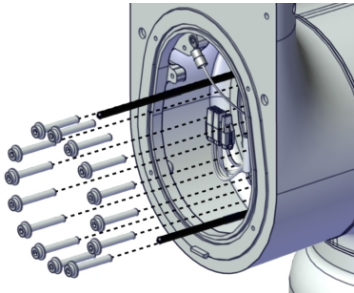
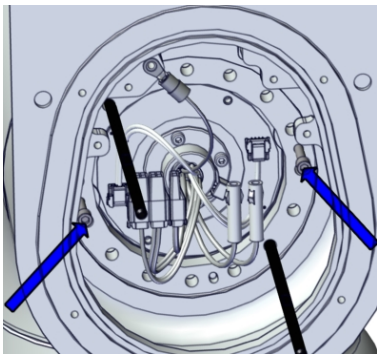
	Action	Note
3	<p>Remove two attachment screws and fit two guide pins to the axis-2 joint unit.</p> <p> CAUTION</p> <p>Do not mix the flange screws used for CRB 15000-5/0.95 and the threaded screws used for CRB 15000-10/1.52 and CRB 15000-12/1.27. Always use washers together with the threaded screws for CRB 15000-10/1.52 and CRB 15000-12/1.27. Illustration is for reference only.</p>	<p>Guide pin, M4x120: 3HAC077786-001</p> <p>Always use guide pins in pairs.</p>  <p>xx2000001951</p>  <p>xx2000001960</p>
4	<p>Remove the lower arm attachment screws.</p> <p> CAUTION</p> <p>Do not mix the flange screws used for CRB 15000-5/0.95 and the threaded screws used for CRB 15000-10/1.52 and CRB 15000-12/1.27. Always use washers together with the threaded screws for CRB 15000-10/1.52 and CRB 15000-12/1.27. Illustration is for reference only.</p>	 <p>xx2000001940</p>
5	<p>Use two fully threaded attachment screws as removal tools to press the lower arm out of position.</p>	 <p>xx2000002151</p>

Continues on next page

5 Repair

5.3.3 Replacing the axis-2 cabling

Continued

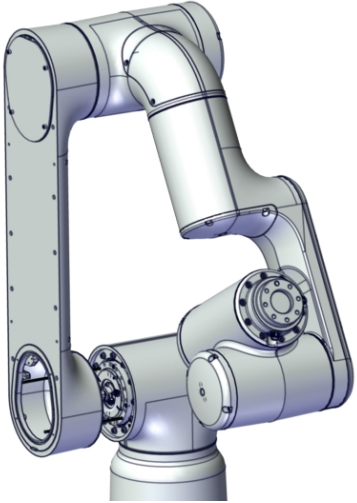
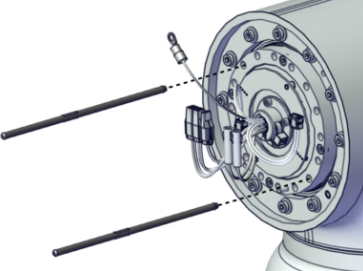
	Action	Note
6	Remove the complete arm system from the swing.	 <p>xx2000001941</p>
7	Remove the guide pins.	 <p>xx2000002432</p>

Removing the swing cover (-5/0.95)

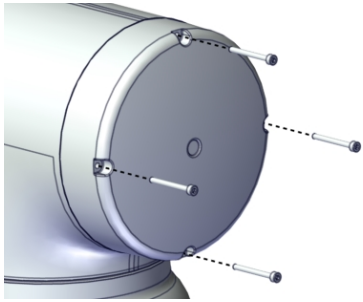
	Action	Note
1	 CAUTION Make sure that all supplies for electrical power are turned off.	
2	Remove the cover screws.	 <p>xx2000001935</p>

Continues on next page

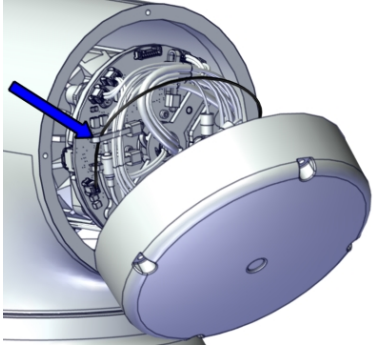
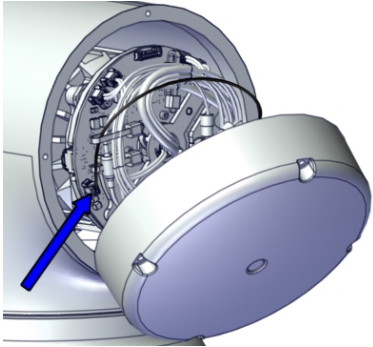
	Action	Note
3	<p> CAUTION</p> <p>Valid for CRB 15000-5/0.95</p> <p>There is cabling connected between the cover and the joint unit drive board.</p> <p>Open the cover with care to avoid damage to the cabling or the connector(s).</p> <p>Do not leave the cover in location without being secured with the attachment screws.</p>	
4	<p>For robots with RobotWare earlier than 7.10</p> <p>Open the cover and cut the cable tie that holds the brake release cable.</p>	 <p>xx2000001931</p>
5	<p>For robots with RobotWare earlier than 7.10</p> <p>Disconnect the brake release connector DR.X8 from the drive board.</p> <p>Remove the cover.</p>	 <p>xx2000001932</p>

Disconnecting the axis-2 joint unit cabling



	Action	Note
1	<p> ELECTROSTATIC DISCHARGE (ESD)</p> <p>The unit is sensitive to ESD. Before handling the unit read the safety information in section The unit is sensitive to ESD on page 53.</p>	

Continues on next page

5 Repair

5.3.3 Replacing the axis-2 cabling

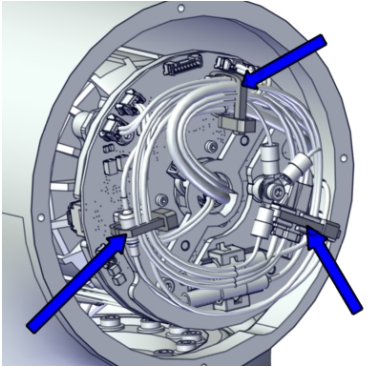
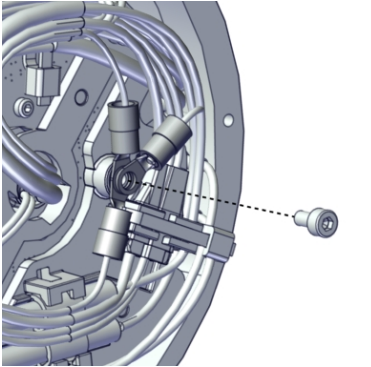
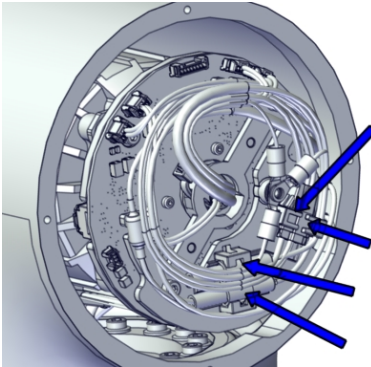
Continued

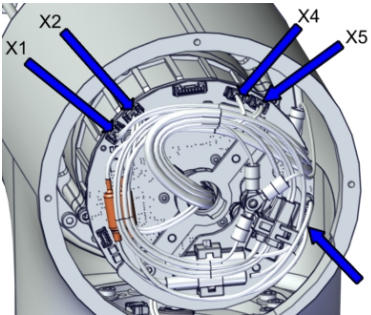
	Action	Note
2	Cut the cable ties.	 <p>xx2000001946</p>
3	Remove the functional and protective earth cables by removing the screw.	 <p>xx2000001945</p>
4	Snap loose and disconnect the connectors: <ul style="list-style-type: none"> • J2.DC+ • J2.DC- • J2.CS • J2.CP 	 <p>xx2000001944</p>
5	Disconnect the connectors from the drive board. <ul style="list-style-type: none"> • D2.X1 from X1 • D2.DC+ from DC+ • D2.DC- from ground • D2.X4 from X4 • D2.X2 from X2 • D2.X5 from X5 <p> CAUTION</p> <p>Use tweezers to unlock connectors and pull them off.</p>	 <p>xx2000002013</p>

Continues on next page

Removing the axis-2 joint unit (-5/0.95)

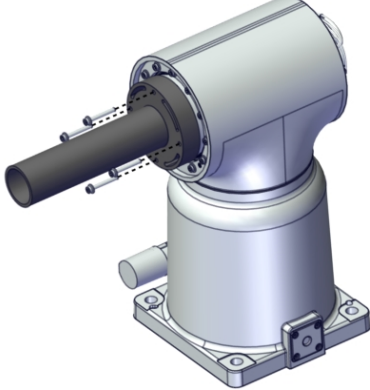
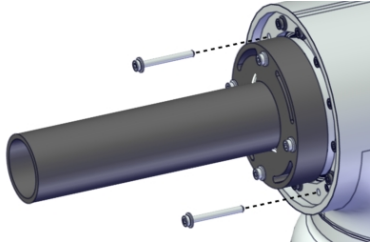
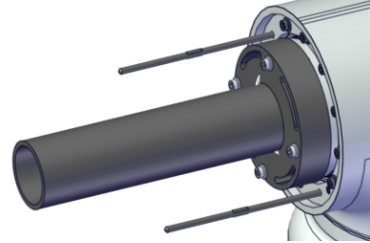
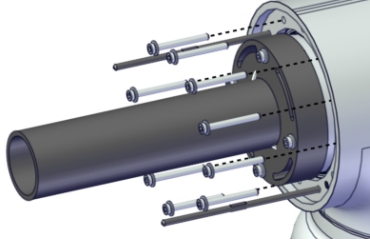

	Action	Note
1	<p>Fit the lifting aid to the joint unit, on the torque sensor side.</p> <p> CAUTION</p> <p>The connectors and the joint unit cables are sensitive to mechanical damage. Handle the assembly with care.</p>	<p>Lifting aid: 3HAC077788-001 Screws: M4x35 (4 pcs)</p>  <p>xx2000001956</p>
2	<p>Remove two attachment screws. Dispose the screws. New screws are included in the spare part delivery of the joint unit.</p>	 <p>xx2100000295</p>
3	<p>Fit two guide pins to the axis-2 joint unit.</p>	<p>Guide pin, M4x120: 3HAC077786-001 Always use guide pins in pairs. For joint units on axes 1, 2 and 3 of CRB 15000-5/0.95 and axis 3 of CRB 15000-10/1.52 and CRB 15000-12/1.27.</p>  <p>xx2000002433</p>
4	<p>Remove the remaining attachment screws. Use two screws as press out screws in the upcoming step, then dispose all screws. New screws are included in the spare part delivery of the joint unit.</p>	 <p>xx2000001943</p>

Continues on next page

5 Repair

5.3.3 Replacing the axis-2 cabling

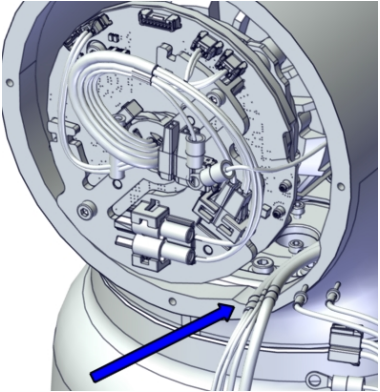
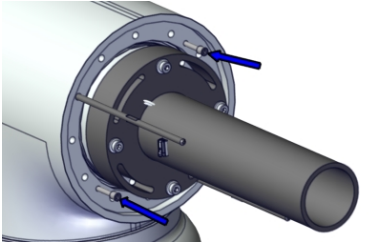
Continued

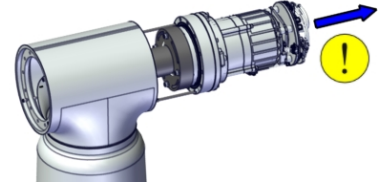
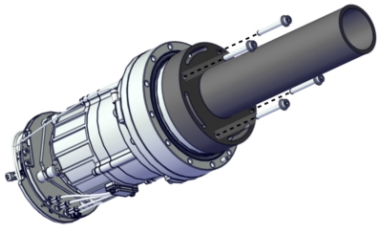
	Action	Note
5	Put the cabling at the slot in order not to squeeze it during removal of joint unit.	 <p>xx2100000045</p>
6	Press the joint unit out of position using two of the previous attachment screws as removal tools.	 <p>xx2000002434</p>
7	<p>Remove the joint unit from the swing.</p> <p> CAUTION</p> <p>The connectors and the joint unit cables are sensitive to mechanical damage. Handle the assembly with care.</p>	 <p>xx2000001958</p>
8	Remove the lifting aid and guide pins.	 <p>xx2000001957</p>

Removing the joint cable

	Action	Note
1	<p> ELECTROSTATIC DISCHARGE (ESD)</p> <p>The unit is sensitive to ESD. Before handling the unit read the safety information in section The unit is sensitive to ESD on page 53.</p>	

Continues on next page

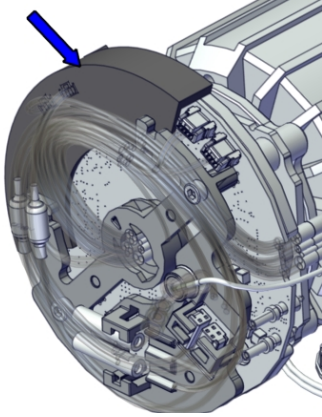
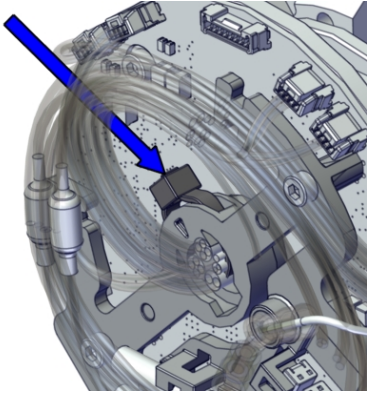
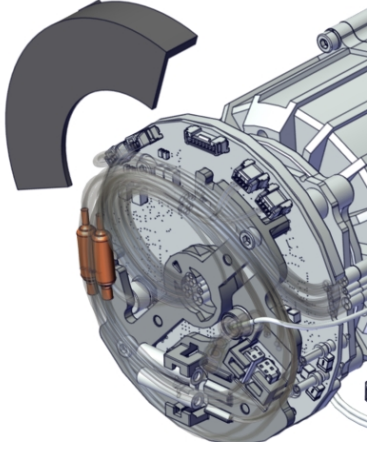

	Action	Note
2	<p>Fit the protection plate to the drive board unit.</p> <p> Tip</p> <p>Using the protection plate is important for protecting the drive board unit. If complete joint unit is to be replaced, the protection plate is not needed.</p>	<p>Protection plate: 3HAC077790-001 (for CRB 15000-5/0.95) / 3HAC087789-001 (for CRB 15000-10/1.52 and CRB 15000-12/1.27)</p>  <p>xx2000002057</p>
3	<p>Cut the cable tie at the drive board.</p>	 <p>xx2000002058</p>
4	<p>Remove the protection plate.</p>	 <p>xx2100000301</p>

Continues on next page

5 Repair

5.3.3 Replacing the axis-2 cabling

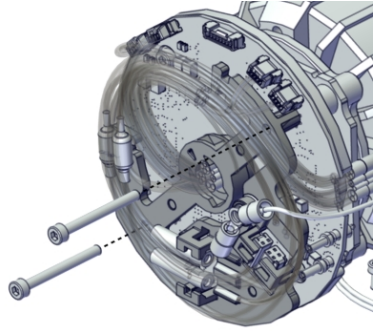
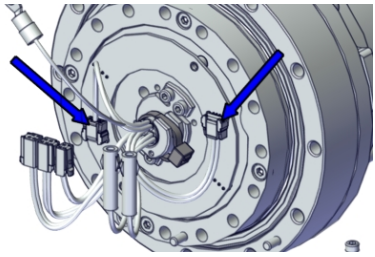
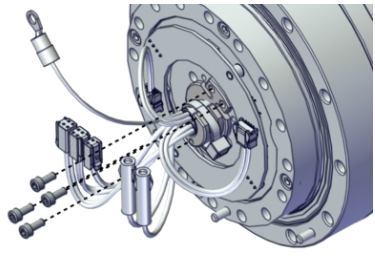
Continued

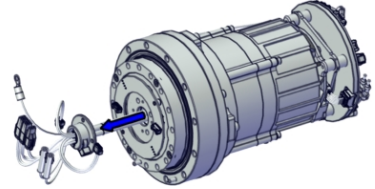

	Action	Note
5	Remove the cable support from the drive board by removing the attachment screws.	 xx2000002055
6	Disconnect the two connectors from the torque sensor board. <ul style="list-style-type: none">• TQ.A• TQ.B	 xx2000002053
7	Remove the cable plate by removing the attachment screws.	 xx2000002049
8	Remove the joint cable from the hollow shaft from the torque sensor side.  CAUTION The connectors and the joint unit cables are sensitive to mechanical damage. Handle the assembly with care.	 xx2000002060

Continues on next page

Removing the joint cabling (-10/1.52 and -12/1.27)

Use these procedures to remove the joint-2 cabling.

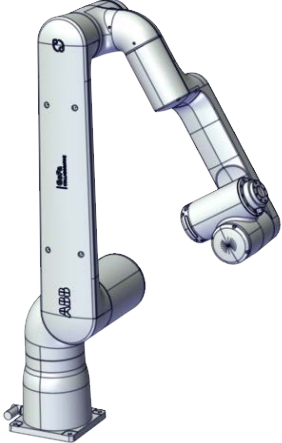
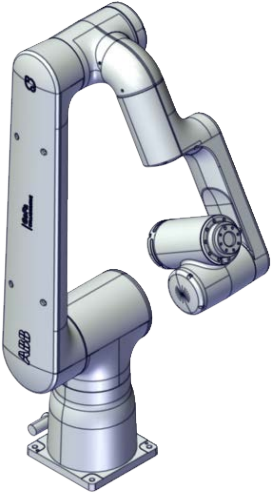
Preparations before removing the cabling

	Action	Note
1	<p>Jog the robot to the specified position:</p> <ul style="list-style-type: none"> • Axis 1: 0° • Axis 2: 0° (home position) • Axis 3: +60° • Axis 4: 0° • Axis 5: -90° • Axis 6: No significance. <p> CAUTION</p> <p>Jog the axis on which the joint unit is to be replaced to home position, to achieve correct cable routing during replacement of the joint unit.</p>	<p>Valid for CRB 15000-10/1.52</p>  <p>xx2300001062</p> <p>Valid for CRB 15000-12/1.27</p>  <p>xx2300001063</p>
2	<p> CAUTION</p> <p>Turn off all supplies for electrical power to the robot, before starting the repair work.</p>	

Continues on next page

5 Repair

5.3.3 Replacing the axis-2 cabling

Continued

Removing the lower arm covers (-10/1.52 and -12/1.27)

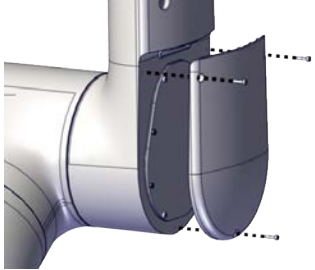
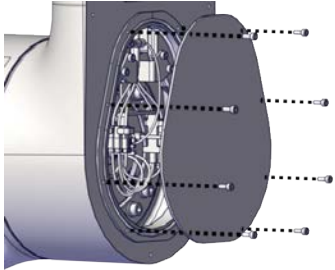
	Action	Note
1	 CAUTION Make sure that all supplies for electrical power are turned off.	
2	Remove the lower cover of lower arm by removing the screws.	 xx2300000812
3	Remove the lower inner cover by removing the screws.	 xx2300000813

Disconnecting the cabling between the lower arm and the swing

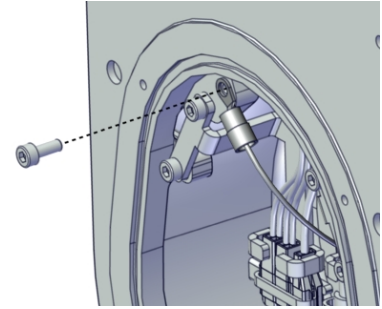
	Action	Note
1	Remove the functional earth cable by removing the screw.	 xx2000001936

Continues on next page

5.3.3 Replacing the axis-2 cabling
Continued

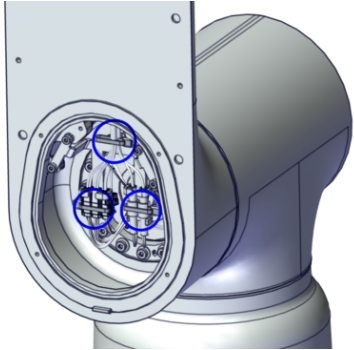
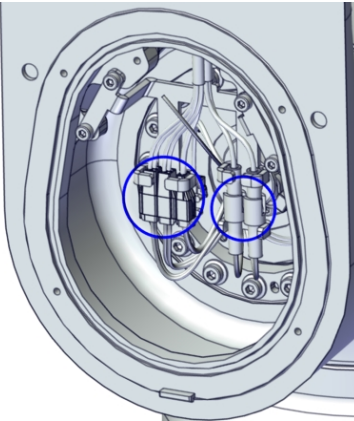
	Action	Note
2	Cut the cable ties.	 <p>xx2000001937</p>
3	Snap loose and disconnect all connectors.	 <p>xx2000001938</p>

Removing the lower and upper arm assembled

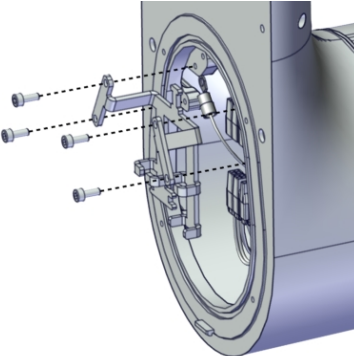
	Action	Note
1	Remove the cable bracket by removing the four screws.	 <p>xx2000001939</p>

Continues on next page



5 Repair

5.3.3 Replacing the axis-2 cabling

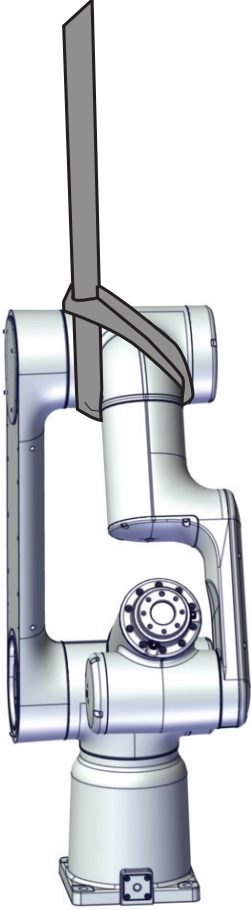
Continued

	Action	Note
2	<p>Secure the weight of the upper and lower arm.</p> <p> CAUTION</p> <p>The weight of the complete upper and lower arm together is up to 26 kg</p>	<p>Suggestion with lifting sling and an overhead crane.</p> <p>Example of CRB 15000-5/0.95, similar to CRB 15000-10/1.52 and CRB 15000-12/1.27.</p>  <p>xx2100000294</p>

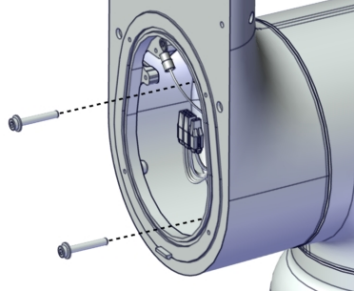
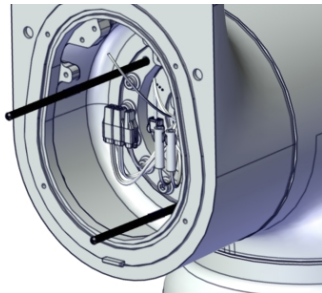
Continues on next page

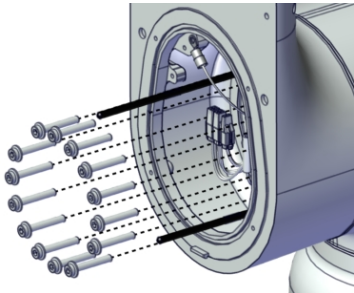
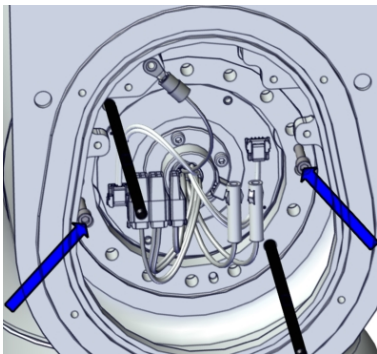
	Action	Note
3	<p>Remove two attachment screws and fit two guide pins to the axis-2 joint unit.</p> <p> CAUTION</p> <p>Do not mix the flange screws used for CRB 15000-5/0.95 and the threaded screws used for CRB 15000-10/1.52 and CRB 15000-12/1.27. Always use washers together with the threaded screws for CRB 15000-10/1.52 and CRB 15000-12/1.27. Illustration is for reference only.</p>	<p>Guide pin, M5x125: 3HAC087786-001</p> <p>Always use guide pins in pairs.</p>  <p>xx2000001951</p>  <p>xx2000001960</p>
4	<p>Remove the lower arm attachment screws.</p> <p> CAUTION</p> <p>Do not mix the flange screws used for CRB 15000-5/0.95 and the threaded screws used for CRB 15000-10/1.52 and CRB 15000-12/1.27. Always use washers together with the threaded screws for CRB 15000-10/1.52 and CRB 15000-12/1.27. Illustration is for reference only.</p>	 <p>xx2000001940</p>
5	<p>Use two fully threaded attachment screws as removal tools to press the lower arm out of position.</p>	 <p>xx2000002151</p>

Continues on next page

5 Repair

5.3.3 Replacing the axis-2 cabling

Continued

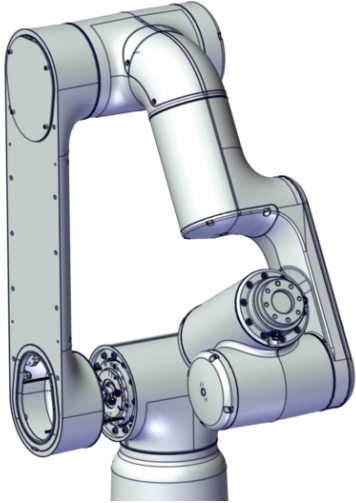
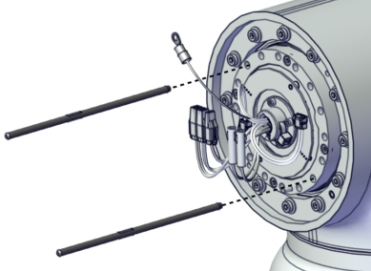
	Action	Note
6	Remove the complete arm system from the swing.	 <p>xx2000001941</p>
7	Remove the guide pins.	 <p>xx2000002432</p>

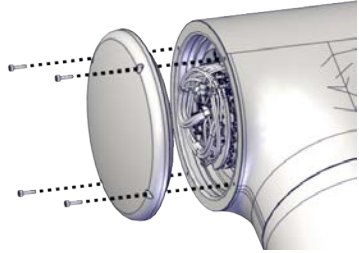

Removing the swing cover and insert (-10/1.52 and -12/1.27)

	Action	Note
1	 CAUTION Make sure that all supplies for electrical power are turned off.	
2	Remove the cover by removing the screws.	 <p>xx2300000814</p>

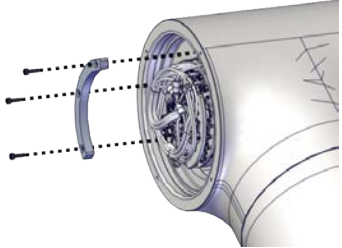
Continues on next page

	Action	Note
3	<p> CAUTION</p> <p>Valid for CRB 15000-5/0.95</p> <p>There is cabling connected between the cover and the joint unit drive board.</p> <p>Open the cover with care to avoid damage to the cabling or the connector(s).</p> <p>Do not leave the cover in location without being secured with the attachment screws.</p>	
4	Remove the insert.	 <p>xx2300000815</p>

Removing the base from foundation (-10/1.52 and -12/1.27)

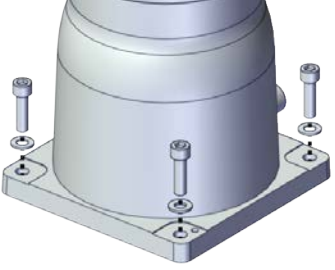
	Action	Note
1	<p> CAUTION</p> <p>The weight of the complete swing and base together is up to 25 kg</p>	
2	<p> WARNING</p> <p>Personnel must not, under any circumstances, be present under the suspended load.</p>	
3	Loosen the robot base from the foundation by removing the foundation attachment screws.	 <p>xx2300001060</p>

Continues on next page



5 Repair

5.3.3 Replacing the axis-2 cabling



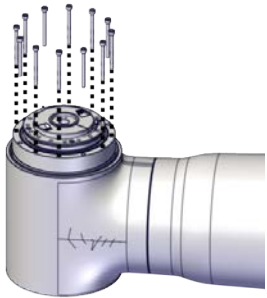

Continued

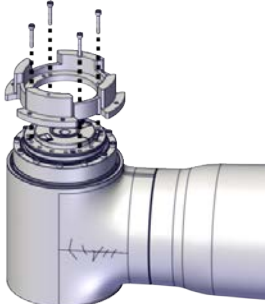
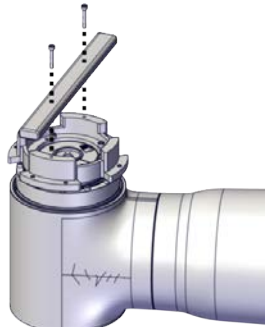
	Action	Note
4	<p>Lay the robot down with the torque sensor side upwards on a working bench. Do not damage the base socket. Caution with the cabling.</p> <p> CAUTION</p> <p>The cabling is sensitive to mechanical damage. Handle it with care to avoid damage to the cabling or the connector, avoid any kind of tilt or skew.</p>	

Removing the axis-2 joint unit

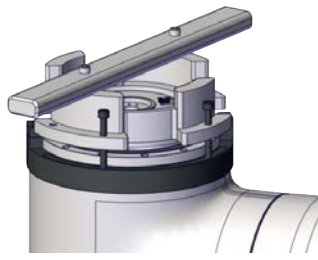
	Action	Note
1	<p>Removing the attachment screws.</p>	 <p>xx2300000786</p>
2	<p>Fit the lifting aid to the joint unit, on the torque sensor side.</p> <p> CAUTION</p> <p>The connectors and the joint unit cables are sensitive to mechanical damage. Handle the assembly with care.</p>	<p>Lifting aid: 3HAC087787-001 Screws: M5x30 (4 pcs for plate and 2 pcs for beam)</p>  <p>xx2300000787</p>  <p>xx2300000788</p>

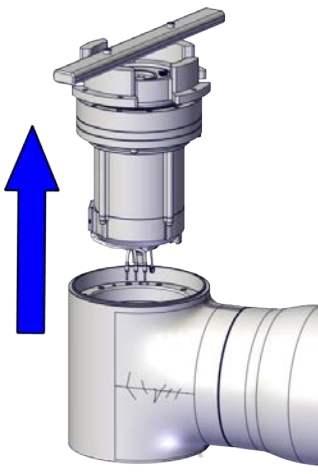
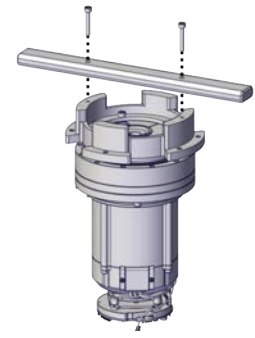
Continues on next page

	Action	Note
3	Place the two semicircular blocks surrounding the joint unit, and use two fully threaded attachment screws as removal tools to press the joint unit out of position.	 <p>xx2300000789</p>
4	<p>Remove the joint unit from the swing.</p> <p> CAUTION</p> <p>The connectors and the joint unit cables are sensitive to mechanical damage. Handle the assembly with care.</p>	 <p>xx2300000790</p>
5	Remove the lifting aid.	 <p>xx2300000778</p>  <p>xx2300000776</p>





Continues on next page

5 Repair

5.3.3 Replacing the axis-2 cabling

Continued

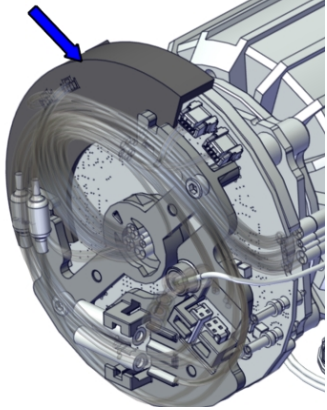
Removing the joint cable

	Action	Note
1	 ELECTROSTATIC DISCHARGE (ESD) The unit is sensitive to ESD. Before handling the unit read the safety information in section <i>The unit is sensitive to ESD on page 53</i> .	
2	Fit the protection plate to the drive board unit.  Tip Using the protection plate is important for protecting the drive board unit. If complete joint unit is to be replaced, the protection plate is not needed.	Protection plate: 3HAC077790-001 (for CRB 15000-5/0.95) / 3HAC087789-001 (for CRB 15000-10/1.52 and CRB 15000-12/1.27)  xx2000002057
3	Cut the cable tie at the drive board.	 xx2000002058

Continues on next page

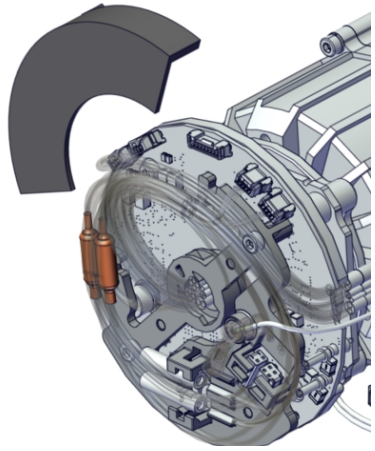
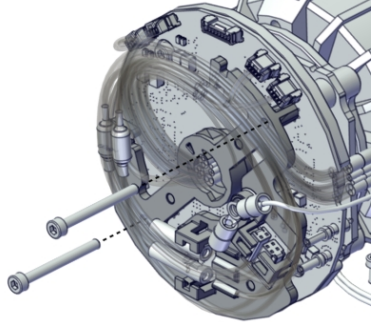
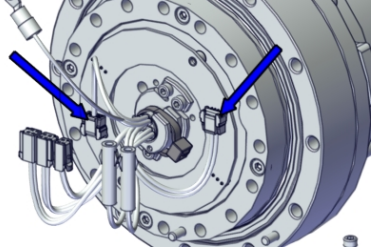
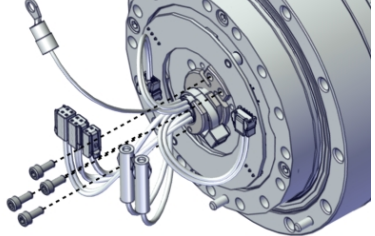
	Action	Note
4	Remove the protection plate.	 <p data-bbox="1066 768 1166 786">xx210000301</p>
5	Remove the cable support from the drive board by removing the attachment screws.	 <p data-bbox="1066 1155 1166 1173">xx200002055</p>
6	Disconnect the two connectors from the torque sensor board. <ul style="list-style-type: none"> • TQ.A • TQ.B 	 <p data-bbox="1066 1462 1166 1480">xx200002053</p>
7	Remove the cable plate by removing the attachment screws.	 <p data-bbox="1066 1771 1166 1789">xx200002049</p>

Continues on next page

5 Repair

5.3.3 Replacing the axis-2 cabling

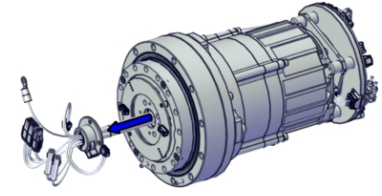

Continued

	Action	Note
8	<p>Remove the joint cable from the hollow shaft from the torque sensor side.</p> <p> CAUTION</p> <p>The connectors and the joint unit cables are sensitive to mechanical damage. Handle the assembly with care.</p>	 <p>xx2000002060</p>

Refitting the joint cabling (-5/0.95)

Use these procedures to refit the joint-2 cabling.

Refitting the joint cable

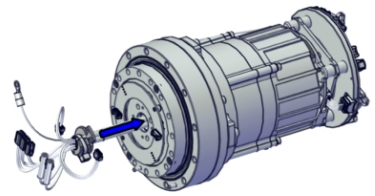
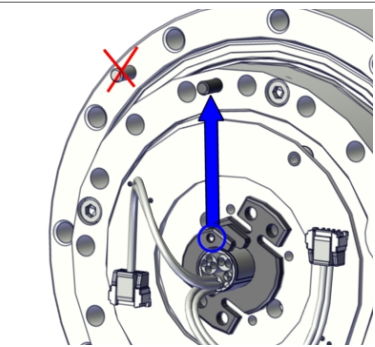
	Action	Note
1	<p> ELECTROSTATIC DISCHARGE (ESD)</p> <p>The unit is sensitive to ESD. Before handling the unit read the safety information in section The unit is sensitive to ESD on page 53.</p>	
2	<p>Place the joint cable through the hollow shaft from the torque sensor side.</p> <p> CAUTION</p> <p>The connectors and the joint unit cables are sensitive to mechanical damage. Handle the assembly with care.</p>	 <p>xx2000002048</p>
3	<p>Orient the cable plate according to the figure. The circle on the cable plate should point towards the guide pin on the torque sensor.</p>	 <p>xx2000002051</p>

Continues on next page

5.3.3 Replacing the axis-2 cabling
Continued

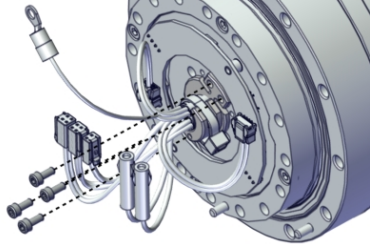
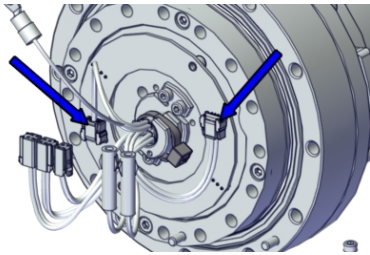
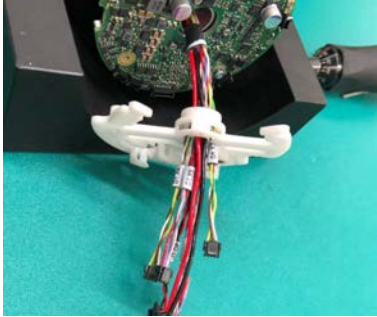
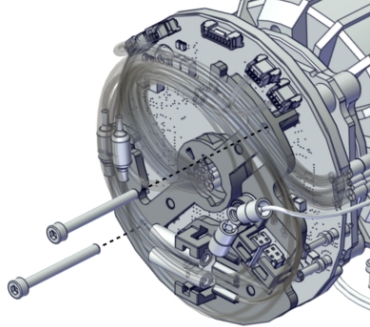
	Action	Note
4	Secure the cable plate to the joint unit with the attachment screws.	<p>Hex socket head cap screw: M2.5x6 12.9 Lafre 2C2B/FC6.9 (4 pcs) Tightening torque: 0.45 Nm.</p>  <p>xx2000002049</p>
5	<p>Connect the two connectors to the torque sensor board.</p> <ul style="list-style-type: none"> • TQ.A to CH1/A • TQ.B to CH2/B 	 <p>xx2000002053</p>
6	Insert the cabling through the cable support and fit the support to the drive board with the attachment screws.	 <p>xx2000002056</p> <p>Hex socket head cap screw: M3x30 12.9 Lafre 2C2B/FC6.9 (2 pcs) Tightening torque: 0.45 Nm.</p>  <p>xx2000002055</p>

Continues on next page

5 Repair

5.3.3 Replacing the axis-2 cabling

Continued

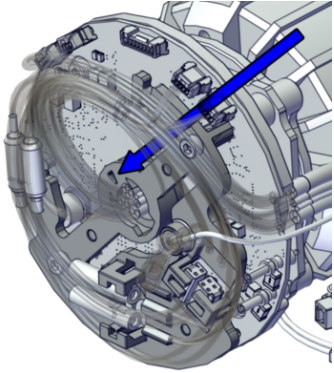
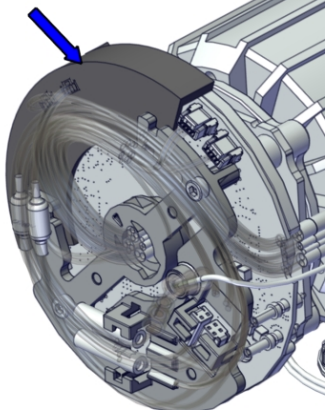
	Action	Note
7	Keep the cabling loose, making sure not to twist or strain it. Use the cable tie to pre-fix the cable by hand.	 xx2100000507
8	Fit the protection plate to the drive board unit.	Protection plate: 3HAC077790-001 (for CRB 15000-5/0.95) / 3HAC087789-001 (for CRB 15000-10/1.52 and CRB 15000-12/1.27)  xx2000002057

Continues on next page

5.3.3 Replacing the axis-2 cabling
Continued

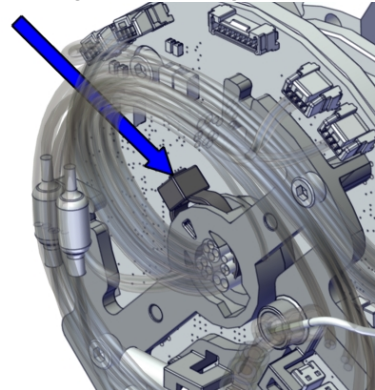
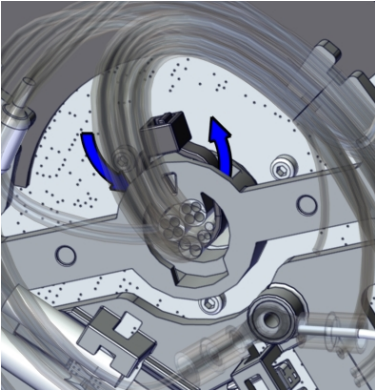
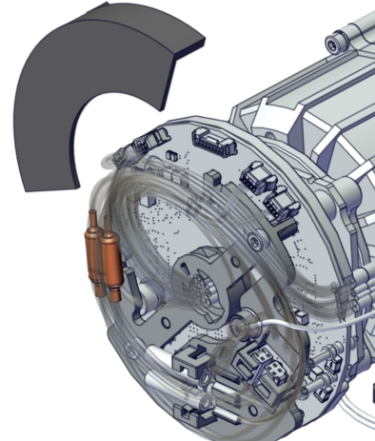
	Action	Note
9	<p>Secure the cables to the cable support with a cable tie, using a cable tie gun.</p> <p>Assembly direction for the cable tie is shown in the figure.</p>	<p>Cable tie: 3HAC075545-001. For securing joint unit cable.</p> <p>Cable tie gun EVO 7i</p> <p>Setting for cable tie gun: 6.75.</p>  <p>xx2000002058</p>  <p>xx2000002059</p>
10	<p>Remove the protection plate.</p>	 <p>xx2100000301</p>



Continues on next page

5 Repair



5.3.3 Replacing the axis-2 cabling

Continued

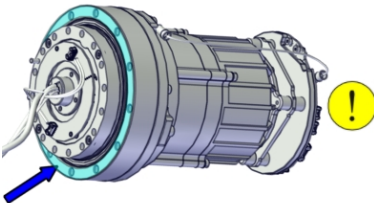



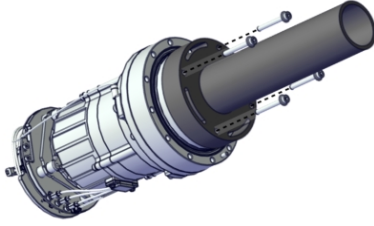

Preparations before fitting the joint unit (-5/0.95)

	Action	Note
1	 ELECTROSTATIC DISCHARGE (ESD) The unit is sensitive to ESD. Before handling the unit read the safety information in section The unit is sensitive to ESD on page 53 .	
2	Clean the mounting surface of the joint unit and the mating surface on the casting with isopropanol. Joint unit mounting surface is pointed out in the figure.	Cleaning agent: Isopropanol Flange sealant: Loctite 574
3	Apply a thin layer of flange sealant to the mounting surface. Do not contaminate the radial sealing with sealant.  CAUTION The connectors and the joint unit cables are sensitive to mechanical damage. Handle the assembly with care.  ELECTROSTATIC DISCHARGE (ESD) The unit is sensitive to ESD. Before handling the unit read the safety information in section The unit is sensitive to ESD on page 53 .	 xx2000001860

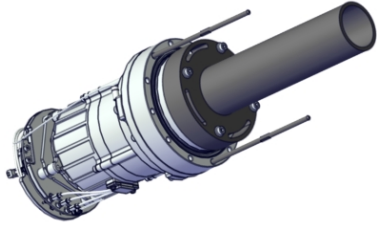
Refitting the axis-2 joint unit (-5/0.95)

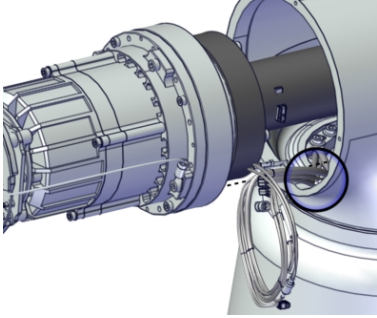
	Action	Note
1	 ELECTROSTATIC DISCHARGE (ESD) The unit is sensitive to ESD. Before handling the unit read the safety information in section The unit is sensitive to ESD on page 53 .	
2	Fit the lifting aid to the joint unit.  CAUTION The connectors and the joint unit cables are sensitive to mechanical damage. Handle the assembly with care.	Joint unit: 3HAC079141-001 Lifting aid: 3HAC077788-001 Screws: M4x35 (4 pcs)  xx2000001957

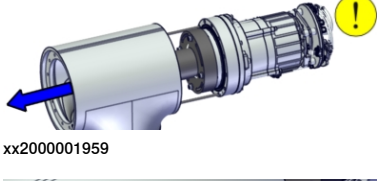
Continues on next page

	Action	Note
3	Fit two guide pins to the joint unit.	<p>Guide pin, M4x120: 3HAC077786-001</p> <p>Always use guide pins in pairs.</p> <p>For joint units on axes 1, 2 and 3 of CRB 15000-5/0.95 and axis 3 of CRB 15000-10/1.52 and CRB 15000-12/1.27.</p>  <p>xx2000002438</p>
4	<p>Place the axis-1 cabling at the notch in the swing.</p> <p> CAUTION</p> <p>The cabling is sensitive to mechanical damage. Handle it with care to avoid damage to the cabling or the connector, avoid any kind of tilt or skew.</p>	 <p>xx2000002153</p>
5	<p>Fit the joint unit to the swing, aligning the pin with the pin hole.</p> <p> CAUTION</p> <p>The connectors and the joint unit cables are sensitive to mechanical damage. Handle the assembly with care.</p>	 <p>xx2000001959</p>  <p>xx2000001961</p>

Continues on next page

5 Repair

5.3.3 Replacing the axis-2 cabling

Continued

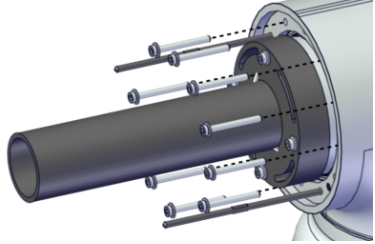
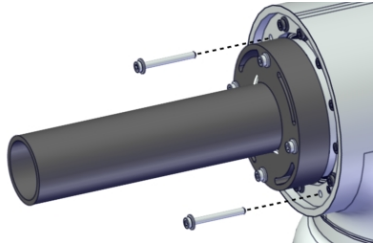
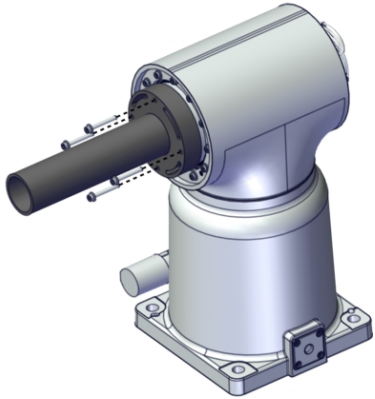
	Action	Note
6	Secure the joint unit with new attachment screws.	<p>Flange socket head screw with glue: 3HAB3413-435 M4x35 12.9 Lafre 2C2B/FC6.9+PrO-COat111, with NYPLAS glue , 12 pcs Used for joint unit of CRB 15000-5/0.95.</p> <p>Always use new screws when refitting a joint unit. If ordering a new joint unit spare part, new screws are included.</p>  <p>xx2000001943</p>
7	Remove the guide pins and secure the remaining two attachment screws.	 <p>xx2100000295</p>
8	Pre-tighten the screws crosswise.	
9	Torque tighten all screws crosswise.	Tightening torque: 4.3 Nm.
10	Remove the lifting aid by removing the screws.	 <p>xx2000001956</p>
11	Clean pushed-out flange sealant, if any.	

Continues on next page

Connecting the axis-2 joint unit cabling

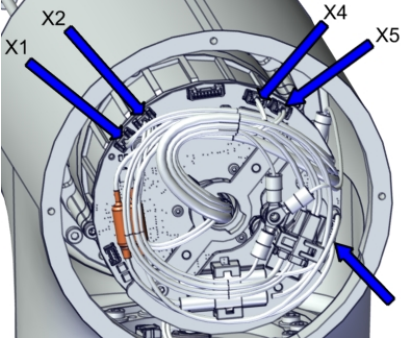
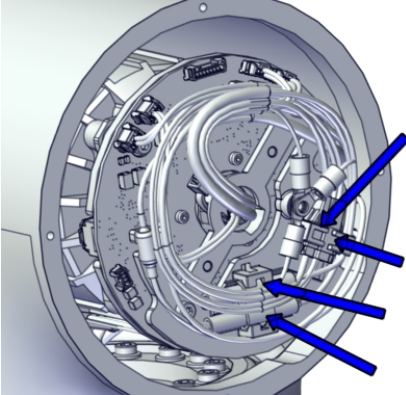
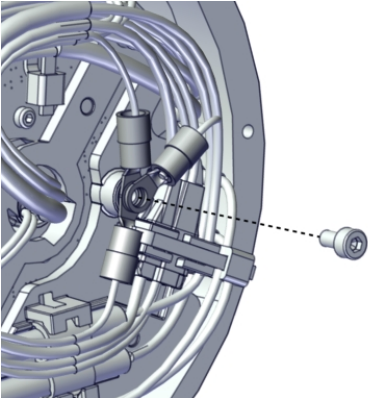
	Action	Note
1	 ELECTROSTATIC DISCHARGE (ESD) The unit is sensitive to ESD. Before handling the unit read the safety information in section <i>The unit is sensitive to ESD on page 53.</i>	
2	Reconnect the connectors to the drive board. <ul style="list-style-type: none"> • D2.X1 to X1 • D2.DC+ to DC+ • D2.DC- to Ground • D2.X4 to X4 • D2.X2 to X2 • D2.X5 to X5 	 xx2000002013
3	Connect the connectors to each other and snap them to the cable holders. <ul style="list-style-type: none"> • J2.DC+ to J2.DC+ • J2.DC- to J2.DC- • J2.CS to J2.CS • J2.CP to J2.CP 	 xx2000001944
4	Secure the cables for functional earth and protective earth with a screw.	Hex socket head cap screw: M3x6 (1 pcs). Tightening torque: 0.8 Nm.  xx2000001945

Continues on next page

5 Repair

5.3.3 Replacing the axis-2 cabling

Continued

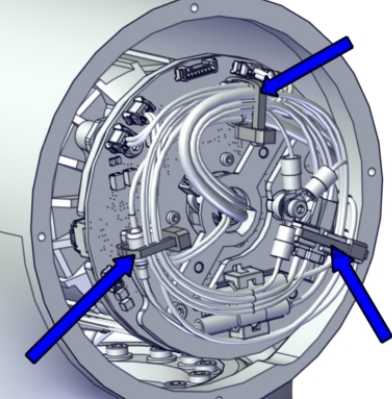
	Action	Note
5	Secure the cabling with cable ties.	Cable ties (3 pcs)  <small>xx2000001946</small>

Refitting the swing cover(-5/0.95)

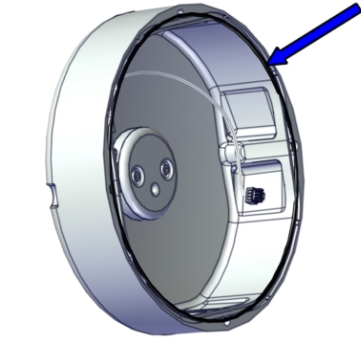
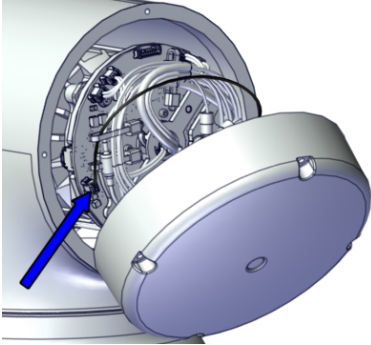
	Action	Note
1	Fit the o-ring to cover groove. Replace if damaged.	O-ring: 3HAC061327-047 (for CRB 15000-5/0.95)  <small>xx2000001962</small>
2	For robots with RobotWare earlier than 7.10 Place the cover at mounting position and reconnect the brake release connector DR.X8 to the drive board. Orient the cover for proper arrangement of the brake release cable.	 <small>xx2000001932</small>

Continues on next page

5.3.3 Replacing the axis-2 cabling
Continued

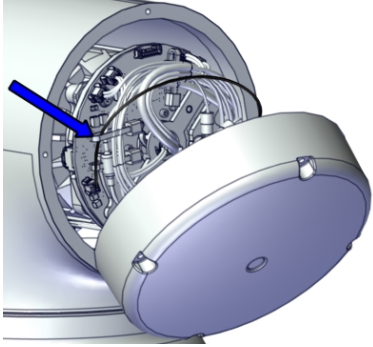
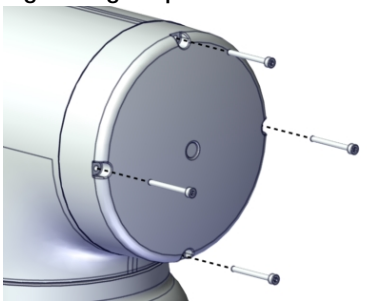
	Action	Note
3	<p>For robots with RobotWare earlier than 7.10 Secure the brake release cable with a cable tie.</p>	<p>Cable ties</p>  <p>xx2000001931</p>
4	<p>Refit the cover with the four screws.</p>	<p>Hex socket head cap screw: M3x30 12.9 Lafre 2C2B/FC6.9 (4 pcs) Tightening torque: 0.45 Nm</p>  <p>xx2000001935</p>

Refitting the lower and upper arm assembled (-5/0.95)

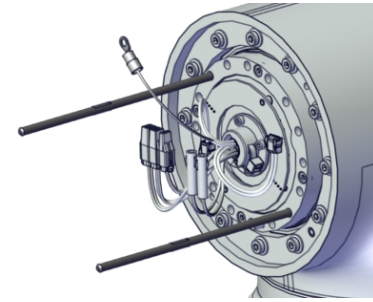



	Action	Note
1	<p>Fit two guide pins to the axis-2 joint unit.</p>	<p>Guide pin, M4x120: 3HAC077786-001</p>  <p>xx2000001949</p>

Continues on next page

5 Repair

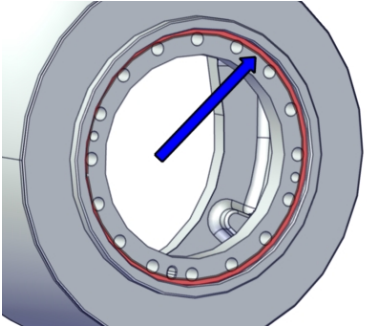
5.3.3 Replacing the axis-2 cabling

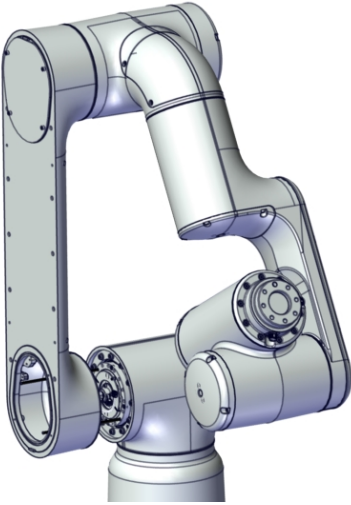
Continued

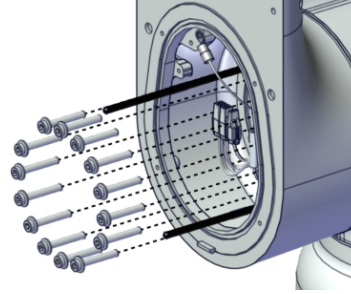
	Action	Note
2	<p>Remove any old residuals of flange sealant from the lower arm mounting surface and clean with isopropanol.</p> <p>Apply new flange sealant to the corner of the lower arm mounting surface, as pointed out in the figure.</p>	<p>Cleaning agent: Isopropanol Flange sealant: Loctite 574</p>  <p>xx2000001963</p>
3	<p> CAUTION</p> <p>The weight of the complete upper and lower arm together is 18 kg</p>	
4	<p>Lift the upper and lower arm assembly to mounting position and slide it onto the guide pins.</p>	 <p>xx2000001941</p>
5	<p>Secure the lower arm to the swing with all attachment screws but two.</p> <p>Pre-tighten the screws crosswise firstly.</p> <p> CAUTION</p> <p>Do not mix the flange screws used for CRB 15000-5/0.95 and the threaded screws used for CRB 15000-10/1.52 and CRB 15000-12/1.27. Always use washers together with the threaded screws for CRB 15000-10/1.52 and CRB 15000-12/1.27. Illustration is for reference only.</p>	<p>Hex socket head cap flange screw: M4x25 12.9 Lafre 2C2B/FC6.9+PrO-COat111 (16 pcs)</p>  <p>xx2000001940</p>

Continues on next page

5.3.3 Replacing the axis-2 cabling
Continued

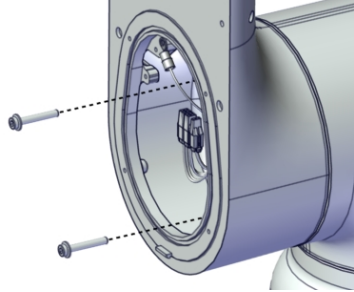
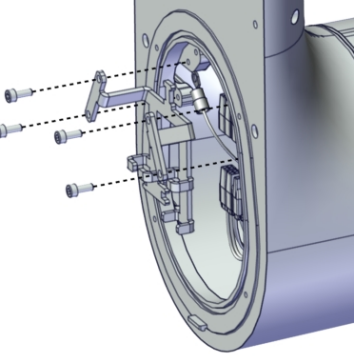
	Action	Note
6	<p>Remove the guide pins and fasten the remaining two screws.</p> <p> CAUTION</p> <p>Do not mix the flange screws used for CRB 15000-5/0.95 and the threaded screws used for CRB 15000-10/1.52 and CRB 15000-12/1.27. Always use washers together with the threaded screws for CRB 15000-10/1.52 and CRB 15000-12/1.27. Illustration is for reference only.</p>	<p>Hex socket head cap flange screw: M4x25 12.9 Lafre 2C2B/FC6.9+PrO-COat111 (16 pcs)</p>  <p>xx2000001951</p>
7	Torque tighten all screws crosswise.	Tightening torque: 4.6 Nm
8	Refit the cable bracket with four screws.	<p>Hex socket head cap screw: M3x8 12.9 Lafre 2C2B/FC6.9 (4 pcs). Tightening torque: 0.8 Nm</p>  <p>xx2000001939</p>

Connecting the cabling between the lower arm and swing

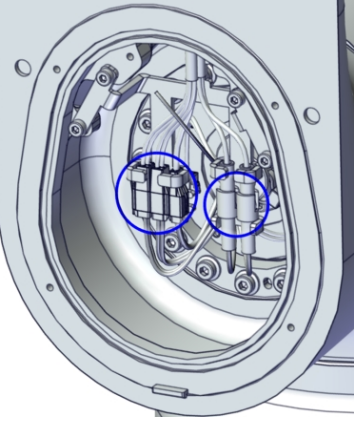
	Action	Note
1	Connect the connectors to each other and snap them to the cable holders.	 <p>xx2000001938</p>

Continues on next page

5 Repair

5.3.3 Replacing the axis-2 cabling

Continued

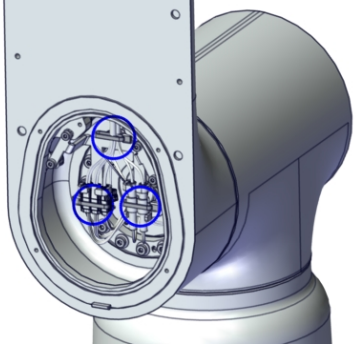
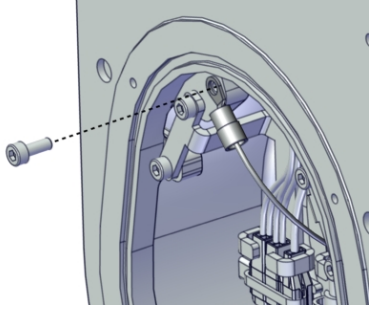
	Action	Note
2	Secure the cabling with cable ties.	Cable ties (3 pcs)  xx2000001937
3	Connect the functional earth cable with the screw.	Hex socket head cap screw: M3x8 12.9 Lafre 2C2B/FC6.9 (1 pcs). Tightening torque: 0.8 Nm  xx2000001936

Refitting the lower arm covers (-5/0.95)

	Action	Note
1	Wipe, lubricate and fit the o-ring to its groove. Replace if damaged.	O-ring: 3HAC061327-044 Grease: 3HAC042536-001 (Shell Gadus S2)  xx2000001954

Continues on next page

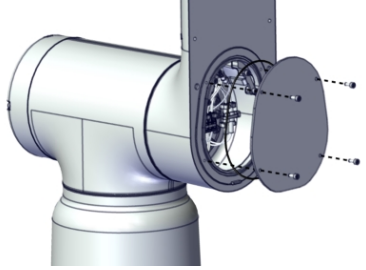
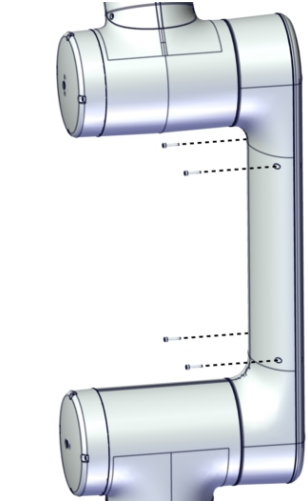
	Action	Note
2	Refit the inner cover with four screws.	<p>Hex socket head cap screw: M3x8 12.9 Lafre 2C2B/FC6.9 (4 pcs) Tightening torque: 1.4 Nm.</p>  <p>xx2000001930</p>
3 4	<p>3 Snap the lower arm cover into place.</p> <p>4 Secure the cover with four screws.</p>	<p>Hex socket head cap screw: M3x16 12.9 Lafre 2C2B/FC6.9 (4 pcs) Tightening torque: 0.45 Nm.</p>  <p>xx2000001929</p>

Continues on next page

5 Repair

5.3.3 Replacing the axis-2 cabling

Continued



Concluding procedure

	Action	Note
1	<p>Calibrate the joint unit torque sensor.</p> <ol style="list-style-type: none"> 1 On the FlexPendant, go to the Code app and call the calibration procedure using PP to Routine, not by using Call Routine. 2 Select the Joint Unit Replacement feature and then select the axis to calibrate. 3 The controller is now restarted. Once the home screen of the FlexPendant is shown, press the Play button to continue the calibration routine. 4 The robot moves to a position or positions where measurements are performed. 5 The results of the measurements are presented together with the current values in the controller. Choose whether to save the calibration data or not. 6 If new calibration data is saved you will be asked to do a test with the lead-through functionality active to verify that the sensors work correctly. 7 Finally the robot is moved back to the original position. 8 Test the brake release (movement without drive power) functionality, see Testing the brake release functionality on page 196. 	See Calibration on page 1063
2	 DANGER Make sure all safety requirements are met when performing the first test run. See Test run after installation, maintenance, or repair on page 90 .	

Refitting the joint cabling (-10/1.52 and -12/1.27)

Use these procedures to refit the joint-2 cabling.

Refitting the joint cable

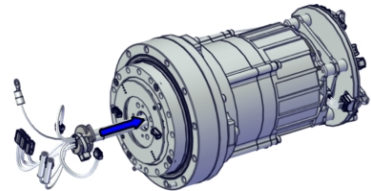
	Action	Note
1	 ELECTROSTATIC DISCHARGE (ESD) The unit is sensitive to ESD. Before handling the unit read the safety information in section The unit is sensitive to ESD on page 53 .	
2	<p>Place the joint cable through the hollow shaft from the torque sensor side.</p>  CAUTION The connectors and the joint unit cables are sensitive to mechanical damage. Handle the assembly with care.	 xx2000002048

Continues on next page

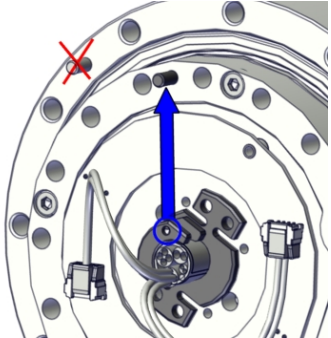
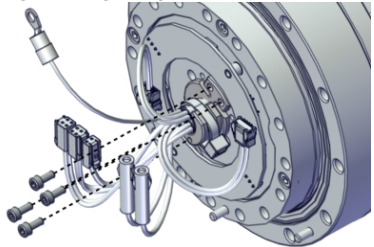
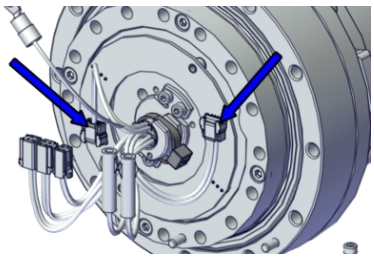
	Action	Note
3	Orient the cable plate according to the figure. The circle on the cable plate should point towards the guide pin on the torque sensor.	 xx2000002051
4	Secure the cable plate to the joint unit with the attachment screws.	Hex socket head cap screw: M2.5x6 12.9 Lafre 2C2B/FC6.9 (4 pcs) Tightening torque: 0.45 Nm.  xx2000002049
5	Connect the two connectors to the torque sensor board. <ul style="list-style-type: none"> • TQ.A to CH1/A • TQ.B to CH2/B 	 xx2000002053

Continues on next page



5 Repair

5.3.3 Replacing the axis-2 cabling

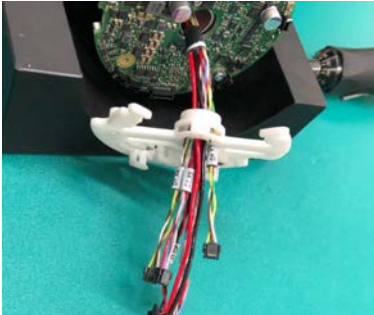
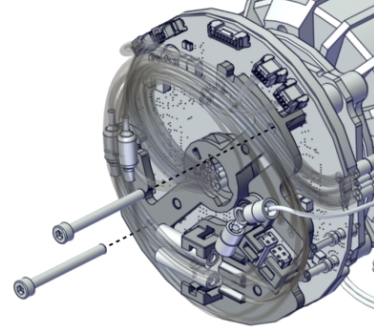
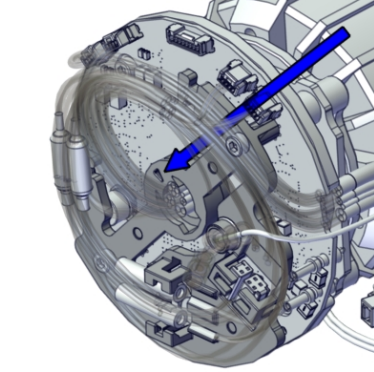
Continued

	Action	Note
6	Insert the cabling through the cable support and fit the support to the drive board with the attachment screws.	 <p data-bbox="1029 636 1139 656">xx2000002056</p> <p data-bbox="1029 674 1410 763">Hex socket head cap screw: M3x30 12.9 Lafre 2C2B/FC6.9 (2 pcs) Tightening torque: 0.45 Nm.</p>  <p data-bbox="1029 1099 1139 1120">xx2000002055</p>
7	Keep the cabling loose, making sure not to twist or strain it. Use the cable tie to pre-fix the cable by hand.	 <p data-bbox="1029 1532 1139 1552">xx2100000507</p>

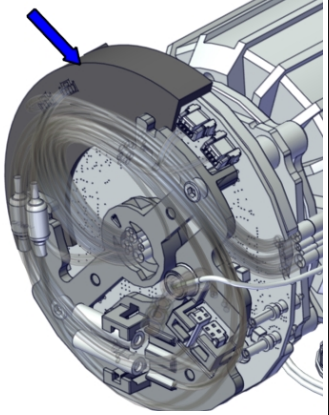
Continues on next page

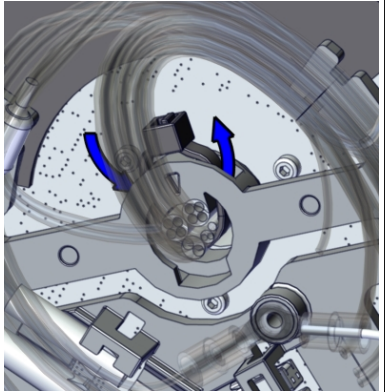
	Action	Note
8	Fit the protection plate to the drive board unit.	<p>Protection plate: 3HAC077790-001 (for CRB 15000-5/0.95) / 3HAC087789-001 (for CRB 15000-10/1.52 and CRB 15000-12/1.27)</p>  <p>xx2000002057</p>
9	<p>Secure the cables to the cable support with a cable tie, using a cable tie gun.</p> <p>Assembly direction for the cable tie is shown in the figure.</p>	<p>Cable tie: 3HAC075545-001. For securing joint unit cable.</p> <p>Cable tie gun EVO 7i</p> <p>Settiing for cable tie gun: 6.75.</p>  <p>xx2000002058</p>  <p>xx2000002059</p>

Continues on next page

5 Repair

5.3.3 Replacing the axis-2 cabling

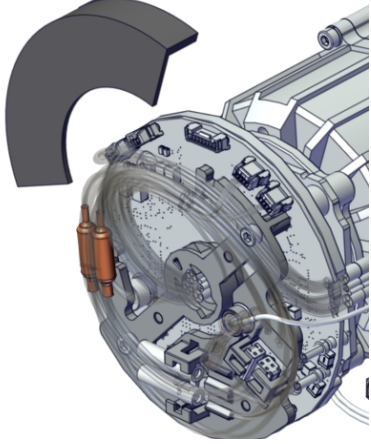

Continued

	Action	Note
10	Remove the protection plate.	 <p data-bbox="1027 770 1134 786">xx2100000301</p>

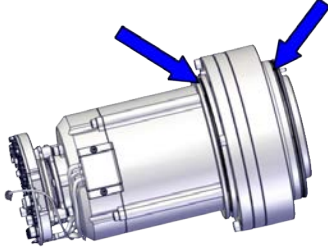
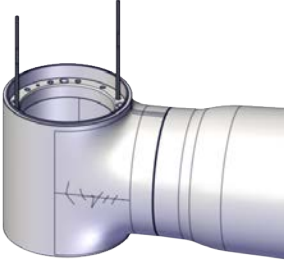
Refitting the axis-2 joint unit (-10/1.52 and -12/1.27)

	Action	Note
1	 <p data-bbox="571 972 1002 1003">ELECTROSTATIC DISCHARGE (ESD)</p> <p data-bbox="480 1039 1018 1115">The unit is sensitive to ESD. Before handling the unit read the safety information in section The unit is sensitive to ESD on page 53.</p>	
2	Check the o-rings. Replace if damaged.	<p data-bbox="1027 1151 1310 1182">O-ring: 3HAC061327-044</p>  <p data-bbox="1027 1458 1134 1473">xx2300000823</p>
3	Fit two guide pins to the swing.	<p data-bbox="1027 1509 1406 1570">Guide pin, M5x125: 3HAC087786-001</p> <p data-bbox="1027 1576 1374 1608">Always use guide pins in pairs.</p> <p data-bbox="1027 1615 1394 1688">For joint units on axes 1 and 2 of CRB 15000-10/1.52 and CRB 15000-12/1.27.</p>  <p data-bbox="1027 1966 1134 1982">xx2300000791</p>

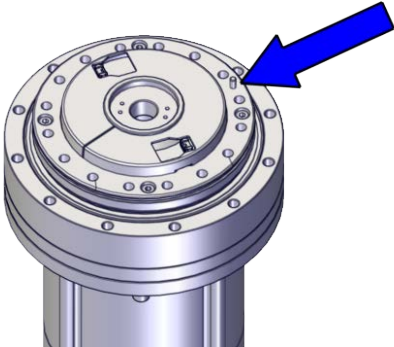
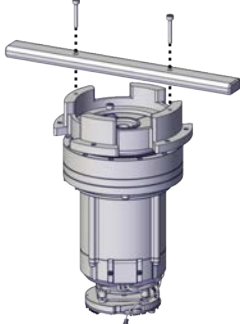
Continues on next page

	Action	Note
4	<p>Fit the lifting aid to the joint unit, aligning the pin with the pin hole.</p> <p> CAUTION</p> <p>The connectors and the joint unit cables are sensitive to mechanical damage. Handle the assembly with care.</p>  <p>xx2300000777</p>	<p>Joint unit: 3HAC087472-001 Lifting aid: 3HAC087787-001 Screws: M5x30 (4 pcs for plate and 2 pcs for beam)</p>  <p>xx2300000778</p>  <p>xx2300000776</p>
5	<p>Place the axis-1 cabling properly to avoid squeezing by the joint unit when putting the joint unit into the swing.</p> <p> CAUTION</p> <p>The cabling is sensitive to mechanical damage. Handle it with care to avoid damage to the cabling or the connector, avoid any kind of tilt or skew.</p>	

Continues on next page

5 Repair

5.3.3 Replacing the axis-2 cabling

Continued

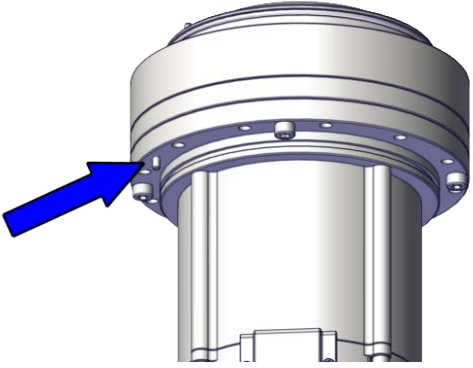
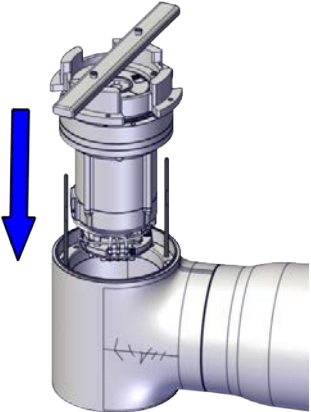
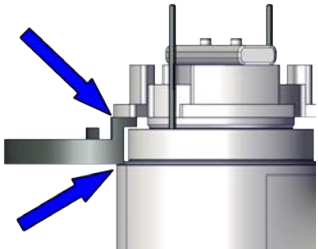
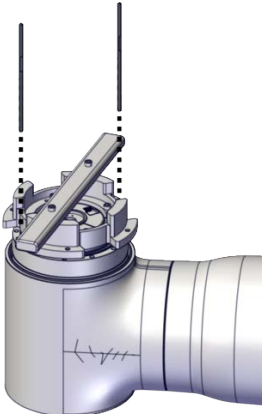
	Action	Note
6	<p>Fit the joint unit to the swing, aligning the pin with the pin hole.</p> <p> CAUTION</p> <p>The connectors and the joint unit cables are sensitive to mechanical damage. Handle the assembly with care.</p>  <p>xx2300000780</p>	 <p>xx2300000792</p>
7	<p>Check the joint unit position by placing the higher boss of one semicircular block between the lifting aid and swing.</p> <p>The joint unit is properly placed when no gaps between the block and both lifting aid and swing.</p>	 <p>xx2300000794</p>
8	<p>Remove the guide pins.</p>	 <p>xx2300000795</p>

Continues on next page

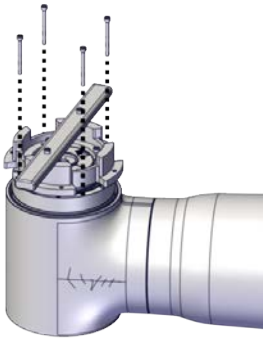
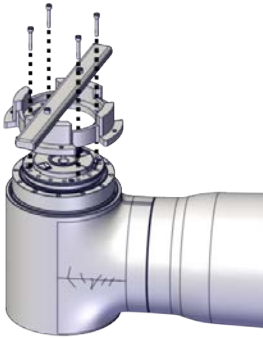
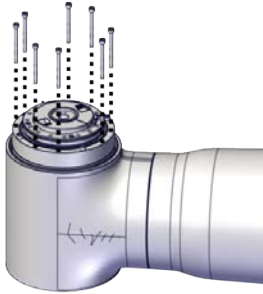
	Action	Note
9	Secure with four attachment screws and pre-tighten the screws crosswise.	 <p>xx2300000796</p>
10	Remove the lifting aid by removing the screws.	 <p>xx2300000797</p>
11	Secure the joint unit with the remaining attachment screws.	<p>Hex socket head cap screw: 3HAB3409-20</p>  <p>xx2300000798</p>
12	Torque tighten all screws crosswise.	<p>M5x55 12.9 Lafre 2C2B/FC6.9, 12 pcs Tightening torque: 8.2 Nm.</p>

Continues on next page

5 Repair

5.3.3 Replacing the axis-2 cabling

Continued

Securing the base (-10/1.52 and -12/1.27)

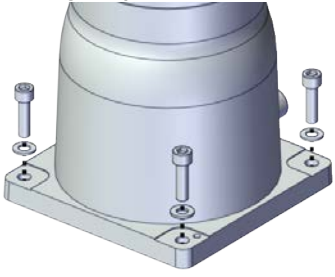
	Action	Note
1	Lift the base to standing and secure it to the foundation with the attachment screws and washers.	<p>Attachment screws: M10x35 8.8 (4 pcs). Washers: 23/10.5/2.5 mm Steel (4 pcs). Tightening torque: 32 Nm \pm10%.</p>  <p>xx2300001060</p>

Connecting the axis-2 joint unit cabling

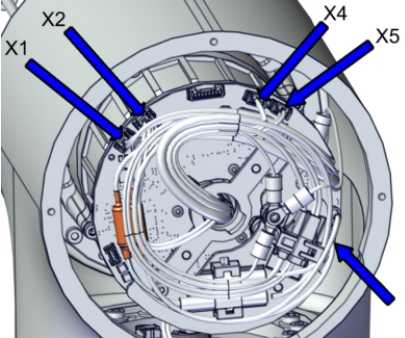
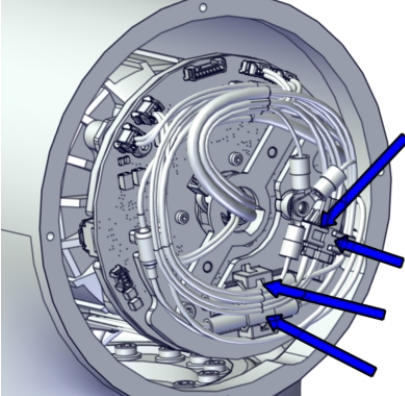
	Action	Note
1	 <p>ELECTROSTATIC DISCHARGE (ESD)</p> <p>The unit is sensitive to ESD. Before handling the unit read the safety information in section The unit is sensitive to ESD on page 53.</p>	
2	<p>Reconnect the connectors to the drive board.</p> <ul style="list-style-type: none"> • D2.X1 to X1 • D2.DC+ to DC+ • D2.DC- to Ground • D2.X4 to X4 • D2.X2 to X2 • D2.X5 to X5 	 <p>xx2000002013</p>
3	<p>Connect the connectors to each other and snap them to the cable holders.</p> <ul style="list-style-type: none"> • J2.DC+ to J2.DC+ • J2.DC- to J2.DC- • J2.CS to J2.CS • J2.CP to J2.CP 	 <p>xx2000001944</p>

Continues on next page

5.3.3 Replacing the axis-2 cabling
Continued

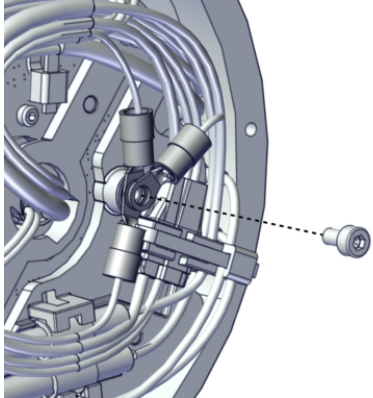
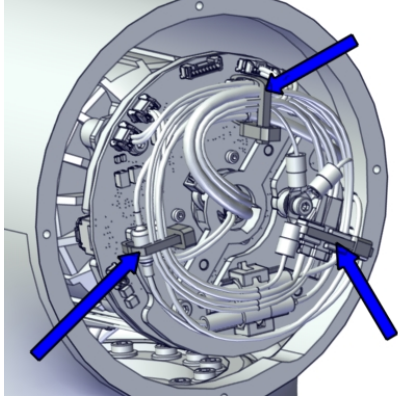
	Action	Note
4	Secure the cables for functional earth and protective earth with a screw.	<p>Hex socket head cap screw: M3x6 (1 pcs). Tightening torque: 0.8 Nm.</p>  <p>xx2000001945</p>
5	Secure the cabling with cable ties.	<p>Cable ties (3 pcs)</p>  <p>xx2000001946</p>

Refitting the swing cover and insert(-10/1.52 and -12/1.27)

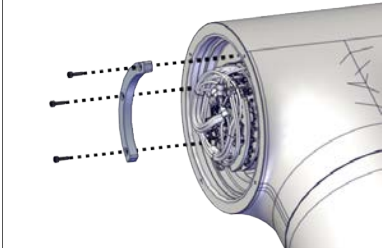
	Action	Note
1	Refit the insert.	<p>Insert: 3HAC084002-001 Hex socket head cap screw: M3x10 12.9 Lafre 2C2B/FC6.9 (3 pcs) Tightening torque: 1.4 Nm</p>  <p>xx2300000815</p>

Continues on next page



5 Repair

5.3.3 Replacing the axis-2 cabling

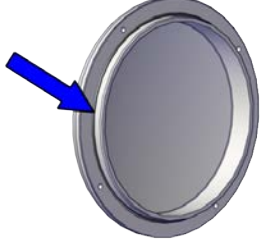
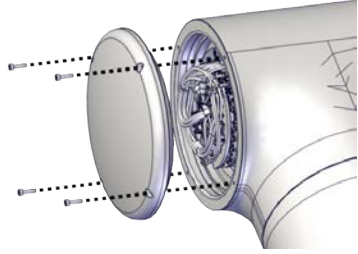

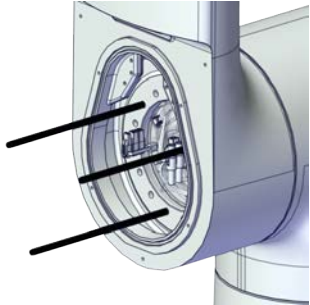

Continued

	Action	Note
2	Fit the o-ring to cover groove. Replace if damaged.	O-ring: 3HAC061327-074 (for CRB 15000-10/1.52 and CRB 15000-12/1.27)  xx2300000816
3	Refit the cover with the four screws.	Hex socket head cap screw: M3x12 12.9 Lafre 2C2B/FC6.9 (4 pcs) Tightening torque: 1.4 Nm  xx2300000814

Refitting the lower and upper arm assembled (-10/1.52 and -12/1.27)

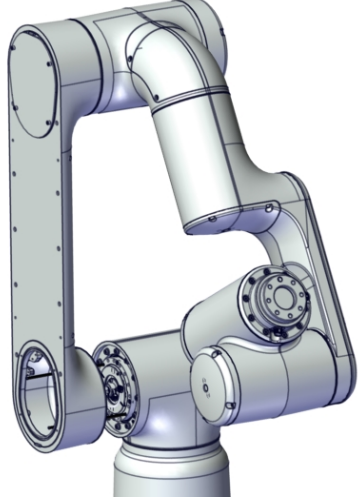
	Action	Note
1	Fit three guide pins to the axis-2 joint unit.	Guide pin, M5x125: 3HAC087786-001  xx2300001021
2	 CAUTION The weight of the complete upper and lower arm together is up to 26 kg	

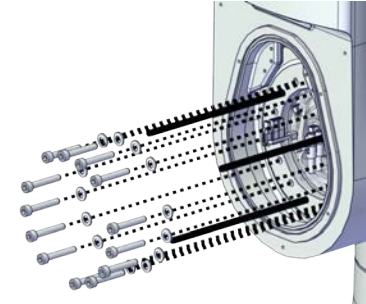
Continues on next page

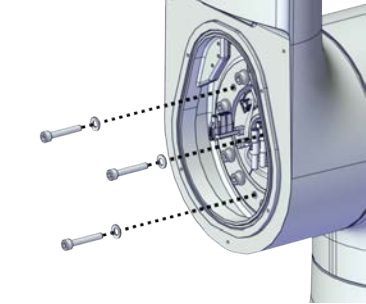
	Action	Note
3	Lift the upper and lower arm assembly to mounting position and slide it onto the guide pins.	<p>Example of CRB 15000-5/0.95, similar to CRB 15000-10/1.52 and CRB 15000-12/1.27.</p>  <p>xx2000001941</p>
4	<p>Secure the lower arm to the swing with all screws and washers but two. Pre-tighten the screws crosswise firstly.</p> <p> CAUTION</p> <p>Do not mix the flange screws used for CRB 15000-5/0.95 and the threaded screws used for CRB 15000-10/1.52 and CRB 15000-12/1.27. Always use washers together with the threaded screws for CRB 15000-10/1.52 and CRB 15000-12/1.27. Illustration is for reference only.</p>	<p>Hex socket head cap screw: M5x30 12.9 Lafre 2C2B/FC6.9, 16 pcs</p>  <p>xx2300001022</p>
5	<p>Remove the guide pins and fasten the remaining two screws and washers.</p> <p> CAUTION</p> <p>Do not mix the flange screws used for CRB 15000-5/0.95 and the threaded screws used for CRB 15000-10/1.52 and CRB 15000-12/1.27. Always use washers together with the threaded screws for CRB 15000-10/1.52 and CRB 15000-12/1.27. Illustration is for reference only.</p>	<p>Hex socket head cap screw: M5x30 12.9 Lafre 2C2B/FC6.9, 16 pcs</p>  <p>xx2300001023</p>
6	Torque tighten all screws crosswise.	Tightening torque: 8.2 Nm

Continues on next page

5 Repair

5.3.3 Replacing the axis-2 cabling

Continued

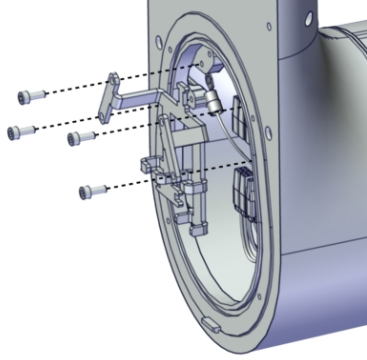
	Action	Note
7	Refit the cable bracket with four screws.	<p>Hex socket head cap screw: M3x8 12.9 Lafre 2C2B/FC6.9 (4 pcs). Tightening torque: 0.8 Nm</p>  <p>xx2000001939</p>

Connecting the cabling between the lower arm and swing

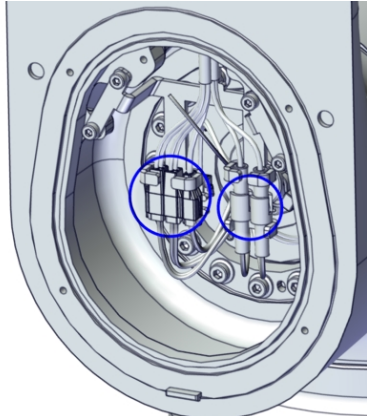
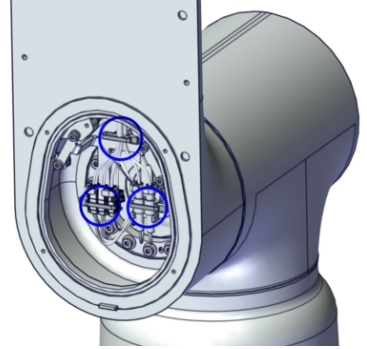
	Action	Note
1	Connect the connectors to each other and snap them to the cable holders.	 <p>xx2000001938</p>
2	Secure the cabling with cable ties.	<p>Cable ties (3 pcs)</p>  <p>xx2000001937</p>

Continues on next page

5.3.3 Replacing the axis-2 cabling
Continued

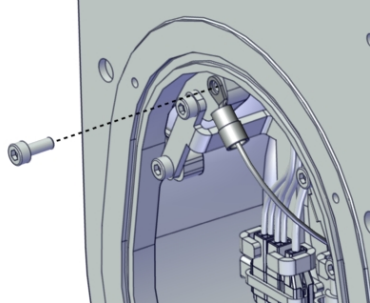
	Action	Note
3	Connect the functional earth cable with the screw.	<p>Hex socket head cap screw: M3x8 12.9 Lafre 2C2B/FC6.9 (1 pcs). Tightening torque: 0.8 Nm</p>  <p>xx2000001936</p>

Removing the lower arm covers (-10/1.52 and -12/1.27)

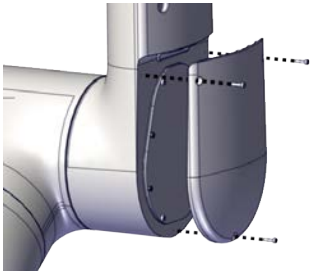
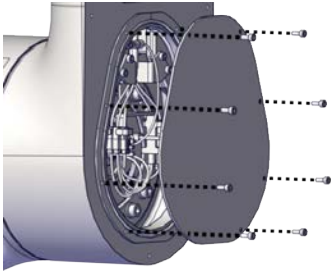
	Action	Note
1	 CAUTION Make sure that all supplies for electrical power are turned off.	
2	Remove the lower cover of lower arm by removing the screws.	 <p>xx2300000812</p>
3	Remove the lower inner cover by removing the screws.	 <p>xx2300000813</p>

Continues on next page

5 Repair

5.3.3 Replacing the axis-2 cabling

Continued

Concluding procedure

	Action	Note
1	<p>Calibrate the joint unit torque sensor.</p> <ol style="list-style-type: none">1 On the FlexPendant, go to the Code app and call the calibration procedure using PP to Routine, not by using Call Routine.2 Select the Joint Unit Replacement feature and then select the axis to calibrate.3 The controller is now restarted. Once the home screen of the FlexPendant is shown, press the Play button to continue the calibration routine.4 The robot moves to a position or positions where measurements are performed.5 The results of the measurements are presented together with the current values in the controller. Choose whether to save the calibration data or not.6 If new calibration data is saved you will be asked to do a test with the lead-through functionality active to verify that the sensors work correctly.7 Finally the robot is moved back to the original position.8 Test the brake release (movement without drive power) functionality, see Testing the brake release functionality on page 196.	See Calibration on page 1063
2	<p> DANGER</p> <p>Make sure all safety requirements are met when performing the first test run. See Test run after installation, maintenance, or repair on page 90.</p>	

5.3.4 Replacing the axis-3 cabling

Location of the cable harness

The cable harness is located as shown in the figure.

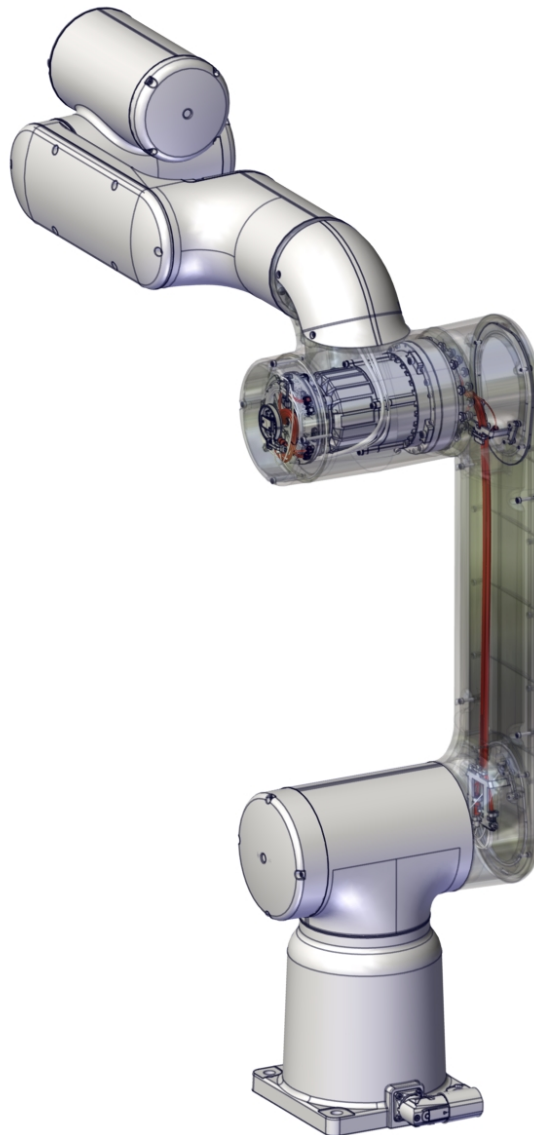

xx210000059

Summary of the replacement procedure

This is a brief summary of the replacement procedure, containing the major actions to be performed.

- 1 Disconnect the cabling between the lower arm and the upper arm.
- 2 Remove the upper arm and place on a workbench.
- 3 Remove the housing cover.
- 4 Remove the axis-3 joint unit.
- 5 Replace the cabling.

Continues on next page

5 Repair

5.3.4 Replacing the axis-3 cabling

Continued

Required spare parts



Note

The spare part numbers that are listed in the table can be out of date. See the latest spare parts of the CRB 15000 via myABB Business Portal, www.abb.com/myABB.

Spare part	Article number	Note
Cable harness, joint 3	3HAC073207-001	Used for CRB 15000-5/0.95. Also order new Cable tie: 3HAC075545-001.
Cable harness, joint 3	3HAC080965-001	Used for CRB 15000-10/1.52 and CRB 15000-12/1.27. Also order new Cable tie: 3HAC075545-001.
Cable tie	3HAC075545-001	For securing joint unit cable.

Required tools and equipment

Equipment	Article number	Note
Lifting aid	3HAC077788-001	For joint units on axes 1, 2 and 3 of CRB 15000-5/0.95. Attachment screws M4x35 (4 pcs) are enclosed.
Lifting aid	3HAC087788-001	For joint unit on axis 3 of CRB 15000-10/1.52 and CRB 15000- 12/1.27.
Guide pin, M4x120	3HAC077786-001	Always use guide pins in pairs. For joint units on axes 1, 2 and 3 of CRB 15000-5/0.95 and axis 3 of CRB 15000-10/1.52 and CRB 15000-12/1.27.
Protection plate	3HAC077790-001	For protection of drive board during cabling installation on joint units of CRB 15000-5/0.95.
Protection plate	3HAC087789-001	For protection of drive board during cabling installation on joint units of CRB 15000-10/1.52 and CRB 15000-12/1.27.
Cable tie gun EVO 7i	-	HellermannTyton 110-77001 or similar
Standard toolkit	-	Content is defined in section Standard toolkit on page 1099 .

Required consumables

Consumable	Article number	Note
Cable ties	-	
O-ring	3HAC061327-047	Cover for axis 2/3, used for CRB 15000-5/0.95. Replace if damaged.



Continues on next page

Consumable	Article number	Note
O-ring	3HAC061327-047	Housing cover, used for CRB 15000-10/1.52 and CRB 15000-12/1.27. Replace if damaged.
O-ring	3HAC061327-044	Lower arm, inner cover of CRB 15000-5/0.95. 1 pcs / cover. Replace if damaged.
O-ring	3HAC061327-044	Lower arm, upper inner cover of CRB 15000-10/1.52 and CRB 15000-12/1.27. Replace if damaged.
Grease	3HAC042536-001	Shell Gadus S2
Cleaning agent	-	Isopropanol
Flange sealant	-	Loctite 574

Removing the joint cabling

Use these procedures to remove the joint-3 cabling.

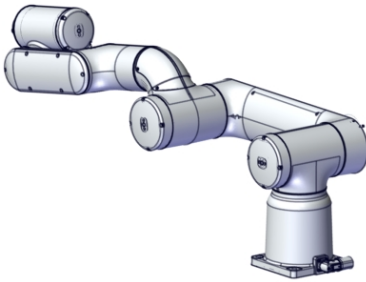
Preparations before removing the cabling

	Action	Note
1	<p>Jog the robot to the specified position:</p> <ul style="list-style-type: none"> • Axis 1: 0° • Axis 2: +90° (suggested position for convenient working position) • Axis 3: -80° (home position) • Axis 4: 0° • Axis 5: 0° • Axis 6: 0° <p> CAUTION</p> <p>Jog the axis on which the joint unit is to be replaced to home position, to achieve correct cable routing during replacement of the joint unit.</p>	<p>Example of CRB 15000-5/0.95, similar to CRB 15000-10/1.52 and CRB 15000-12/1.27.</p>  <p>xx210000002</p>
2	<p> CAUTION</p> <p>Turn off all supplies for electrical power to the robot, before starting the repair work.</p>	

Removing the lower arm covers (-5/0.95)

	Action	Note
1	<p> CAUTION</p> <p>Make sure that all supplies for electrical power are turned off.</p>	

Continues on next page

5 Repair

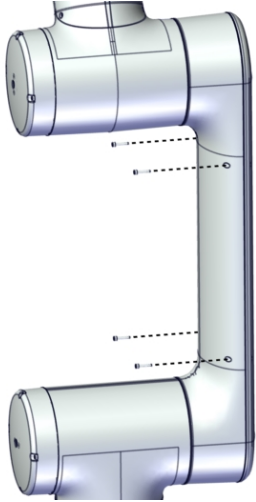
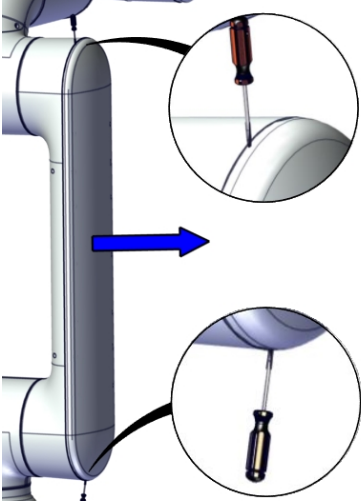
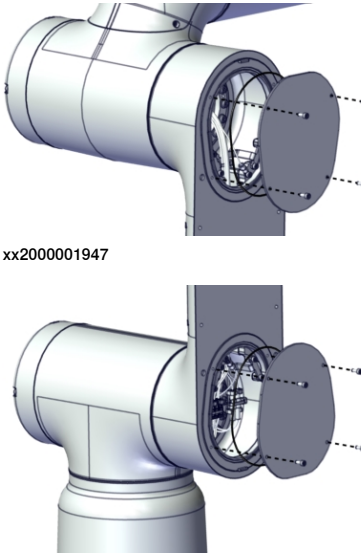

5.3.4 Replacing the axis-3 cabling

Continued

	Action	Note
2	Remove the four lower arm cover screws.	 <p>xx200001929</p>
3	Remove the cover by inserting a small flat screwdriver to snap open the locks at each end of the cover.	 <p>xx210000267</p>
4	Remove the inner covers by removing the screws.	 <p>xx200001947</p> <p>xx200001930</p>

Continues on next page

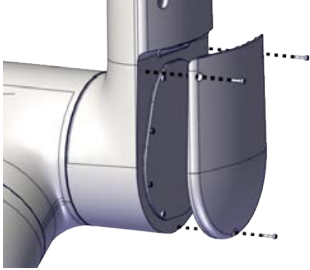
Removing the lower arm covers (-10/1.52 and -12/1.27)

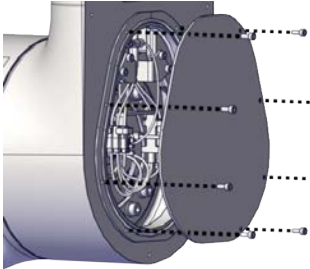
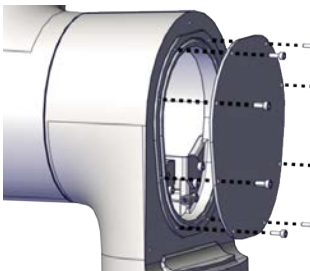
	Action	Note
1	<p> CAUTION</p> <p>Make sure that all supplies for electrical power are turned off.</p>	
2	<p>Remove the lower arm covers by removing the screws.</p>	 <p>xx2300000812</p>  <p>xx2300000829</p>
3	<p>Remove the inner covers by removing the screws.</p>	 <p>xx2300000813</p>  <p>xx2300000830</p>

Continues on next page

5 Repair

5.3.4 Replacing the axis-3 cabling

Continued

Disconnecting the upper arm cabling

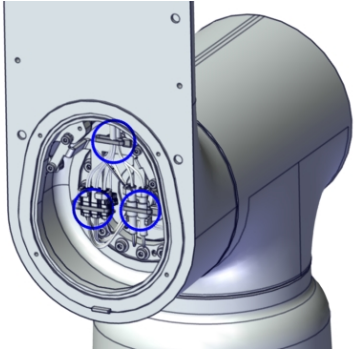
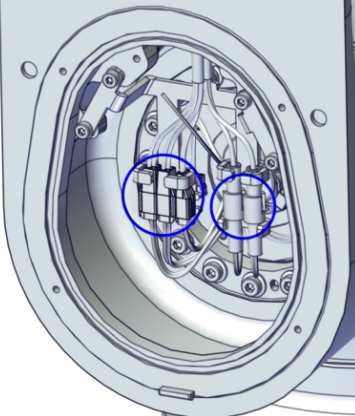

	Action	Note
1	Cut the cable ties.	 xx2000001937
2	Snap loose and disconnect all connectors.	 xx2000001938

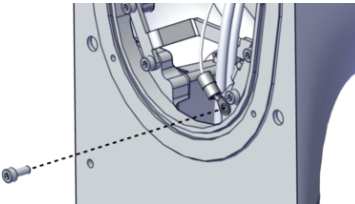
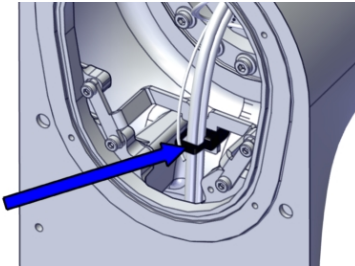
Loosening the cabling between the lower and upper arm

	Action	Note
1	Remove the functional earth cable by removing the screw.	 xx2000001964
2	Cut the cable tie.	 xx2000001965

Continues on next page

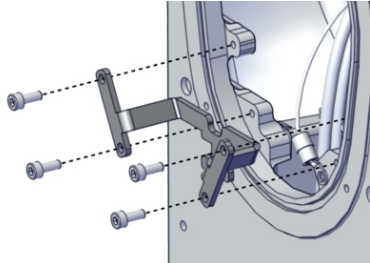
Removing the upper arm

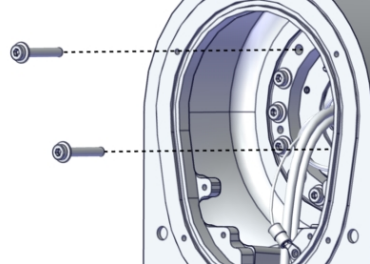
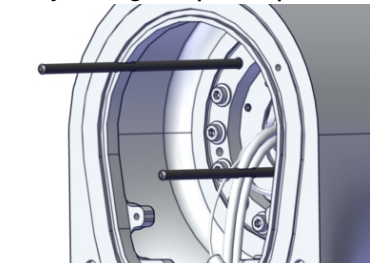
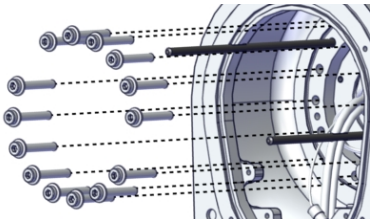
	Action	Note
1	Remove the cable bracket by removing the four screws.	 <p>xx2000001966</p>
2	Secure the weight of the upper arm.  CAUTION The weight of the complete upper arm is 14 kg.	
3	Remove two attachment screws.	 <p>xx2000001967</p>
4	Fit two guide pins to the axis-3 joint unit.	Guide pin, M4x120: 3HAC077786-001 Always use guide pins in pairs.  <p>xx2000001968</p>
5	Remove the remaining attachment screws.	 <p>xx2000001969</p>

Continues on next page



5 Repair

5.3.4 Replacing the axis-3 cabling

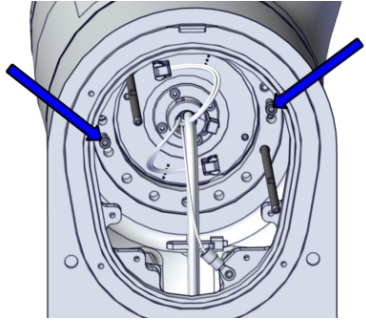
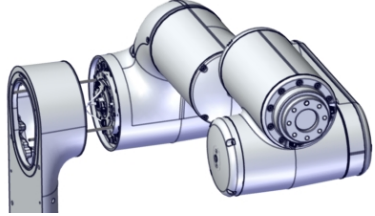
Continued

	Action	Note
6	Press the upper arm out of position by using two fully threaded attachment screws as removal tools.	 xx210000001
7	Remove the upper arm from the lower arm. Assist the cabling to be removed from the lower arm while lifting away the complete upper arm. Place the upper arm on a workbench.	 xx2000001970

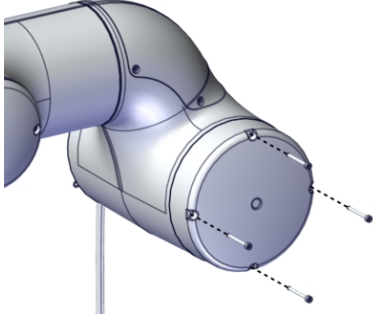
Removing the housing cover (-5/0.95)



	Action	Note
1	 CAUTION Make sure that all supplies for electrical power are turned off.	
2	Remove the cover screws.	 xx2000002021
3	 CAUTION Valid for CRB 15000-5/0.95 There is cabling connected between the cover and the joint unit drive board. Open the cover with care to avoid damage to the cabling or the connector(s). Do not leave the cover in location without being secured with the attachment screws.	

Continues on next page

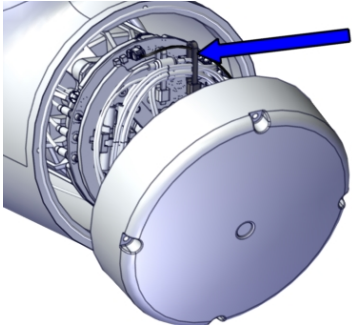
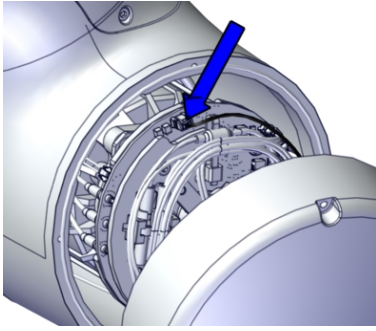
5.3.4 Replacing the axis-3 cabling
Continued

	Action	Note
4	<p>For robots with RobotWare earlier than 7.10 Open the cover and cut the cable tie that holds the brake release cable.</p>	 <p>xx2000002022</p>
5	<p>For robots with RobotWare earlier than 7.10 Disconnect the brake release connector DR.X8 from the drive board. Remove the cover.</p>	 <p>xx2000002023</p>

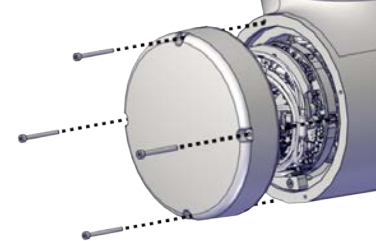
Removing the housing cover and insert (-10/1.52 and -12/1.27)

	Action	Note
1	<p> CAUTION Make sure that all supplies for electrical power are turned off.</p>	
2	<p>Remove the cover by removing the screws.</p>	 <p>xx2300000833</p>
3	<p> CAUTION Valid for CRB 15000-5/0.95 There is cabling connected between the cover and the joint unit drive board. Open the cover with care to avoid damage to the cabling or the connector(s). Do not leave the cover in location without being secured with the attachment screws.</p>	

Continues on next page

5 Repair

5.3.4 Replacing the axis-3 cabling

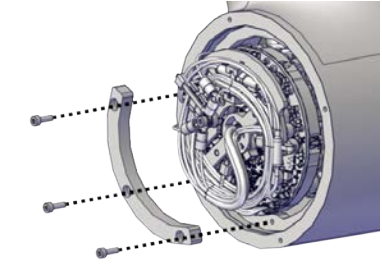

Continued

	Action	Note
4	Remove the insert.	 xx2300000834

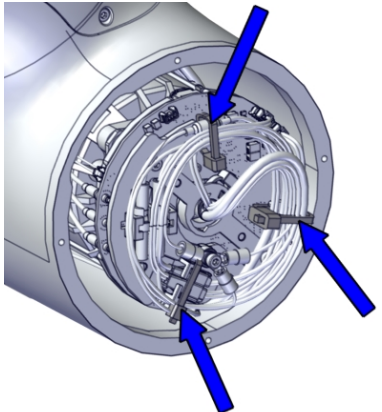
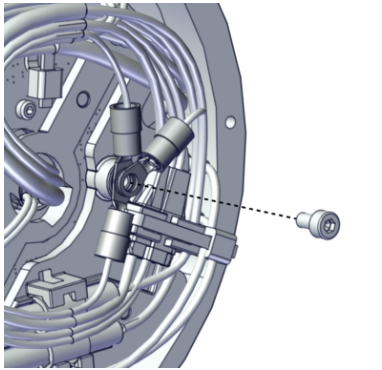
Disconnecting the axis-3 joint unit cabling

	Action	Note
1	Cut the cable ties.	 xx2000002066
2	Remove the functional and protective earth cables by removing the screw.	 xx2000001945

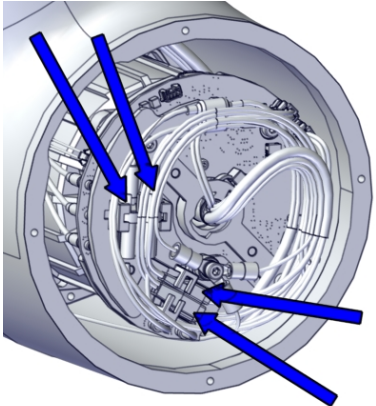
Continues on next page

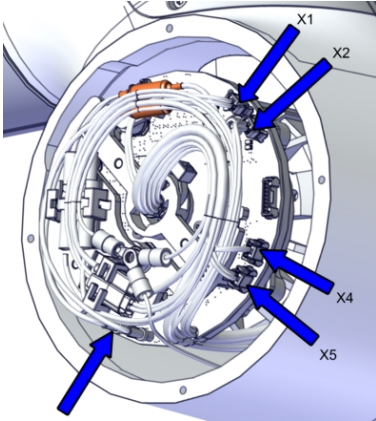
	Action	Note
3	Snap loose and disconnect the connectors: <ul style="list-style-type: none"> • J4.DC+ • J4.DC- • J4.CS • J4.CP 	 <p>xx2000002067</p>
4	Disconnect the connectors from the drive board. <ul style="list-style-type: none"> • D3.X1 • D3/4.DC+ • D3/4.DC- • D3.X4 • D3/4.X2 • D3.X5 <p> CAUTION</p> Use tweezers to unlock connectors and pull them off.	 <p>xx2000002068</p>

Removing the axis-3 joint unit (-5/0.95)

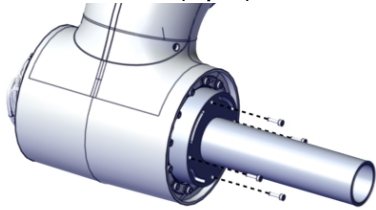
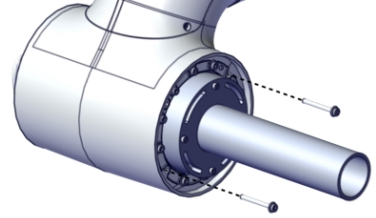

	Action	Note
1	Fit the lifting aid to the joint unit, on the torque sensor side. <p> CAUTION</p> The connectors and the joint unit cables are sensitive to mechanical damage. Handle the assembly with care.	Lifting aid: 3HAC077788-001 Screws: M4x35 (4 pcs)  <p>xx2000002069</p>
2	Remove two attachment screws. Dispose the screws. New screws are included in the spare part delivery of the joint unit.	 <p>xx2000002070</p>

Continues on next page

5 Repair

5.3.4 Replacing the axis-3 cabling

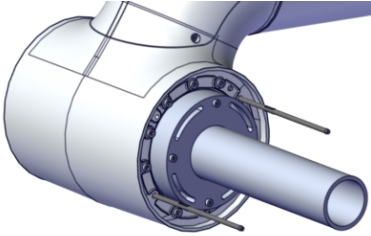
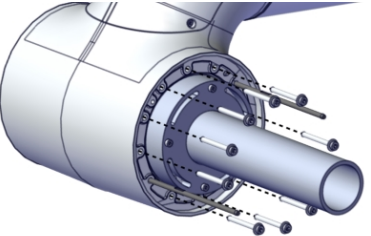

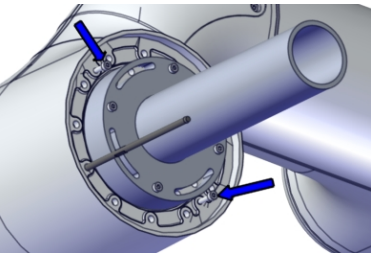
Continued

	Action	Note
3	Fit two guide pins to the axis-3 joint unit.	<p>Guide pin, M4x120: 3HAC077786-001</p> <p>Always use guide pins in pairs.</p> <p>For joint units on axes 1, 2 and 3 of CRB 15000-5/0.95 and axis 3 of CRB 15000-10/1.52 and CRB 15000-12/1.27.</p>  <p>xx2000002576</p>
4	<p>Remove the remaining attachment screws.</p> <p>Use two screws as press out screws in the upcoming step, then dispose all screws.</p> <p>New screws are included in the spare part delivery of the joint unit.</p>	 <p>xx2100000320</p>
5	Put the cabling at the slot in order not to squeeze it during removal of joint unit.	 <p>xx2100000003</p>
6	Press the joint unit out of position using two of the previous attachment screws as removal tools.	 <p>xx2000002577</p>

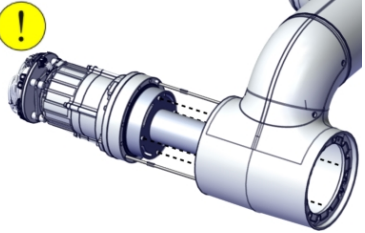
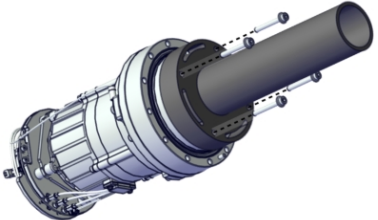
Continues on next page

	Action	Note
7	Remove the joint unit from the housing.  CAUTION The connectors and the joint unit cables are sensitive to mechanical damage. Handle the assembly with care.	 xx2000002071
8	Remove the lifting aid and guide pins.	 xx2000001957

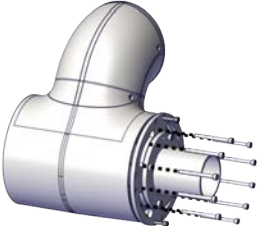
Removing the axis-3 joint unit (-10/1.52 and -12/1.27)

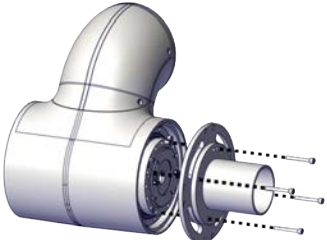
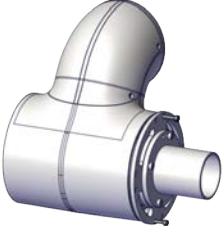
	Action	Note
1	Remove the attachment screws.	 xx2300000799
2	Fit the lifting aid to the joint unit, on the torque sensor side.  CAUTION The connectors and the joint unit cables are sensitive to mechanical damage. Handle the assembly with care.	Lifting aid: 3HAC087788-001 Screws: M4x30 (4 pcs)  xx2300000800
3	Use two fully attachment screws as removal tools to press the joint unit out of position.	 xx2300000801

Continues on next page



5 Repair

5.3.4 Replacing the axis-3 cabling

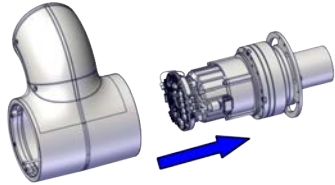
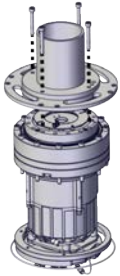
Continued

	Action	Note
4	<p>Remove the joint unit from the housing.</p> <p> CAUTION</p> <p>The connectors and the joint unit cables are sensitive to mechanical damage. Handle the assembly with care.</p>	 <p>xx2300000802</p>
5	<p>Remove the lifting aid.</p>	 <p>xx2300000804</p>

Removing the joint cable

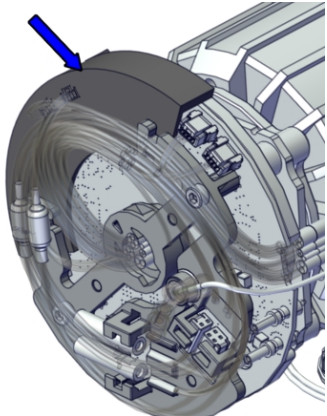
	Action	Note
1	<p> ELECTROSTATIC DISCHARGE (ESD)</p> <p>The unit is sensitive to ESD. Before handling the unit read the safety information in section The unit is sensitive to ESD on page 53.</p>	
2	<p>Fit the protection plate to the drive board unit.</p> <p> Tip</p> <p>Using the protection plate is important for protecting the drive board unit. If complete joint unit is to be replaced, the protection plate is not needed.</p>	<p>Protection plate: 3HAC077790-001 (for CRB 15000-5/0.95) / 3HAC087789-001 (for CRB 15000-10/1.52 and CRB 15000-12/1.27)</p>  <p>xx2000002057</p>

Continues on next page

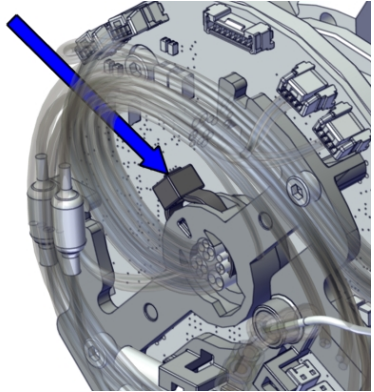
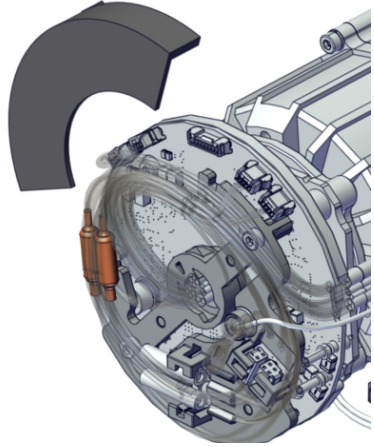
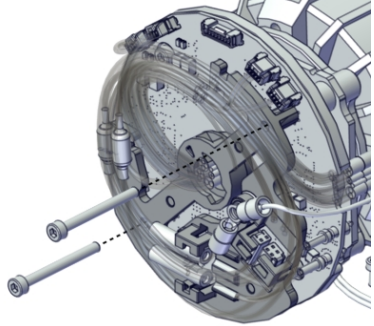
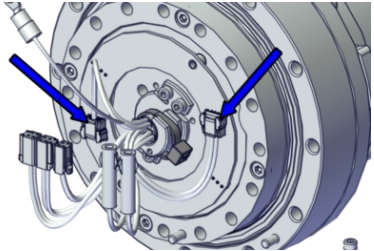

	Action	Note
3	Cut the cable tie at the drive board.	 <p>xx2000002058</p>
4	Remove the protection plate.	 <p>xx2100000301</p>
5	Remove the cable support from the drive board by removing the attachment screws.	 <p>xx2000002055</p>
6	Disconnect the two connectors from the torque sensor board. <ul style="list-style-type: none"> • TQ.A • TQ.B 	 <p>xx2000002053</p>

Continues on next page

5 Repair

5.3.4 Replacing the axis-3 cabling

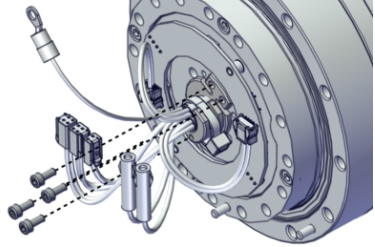

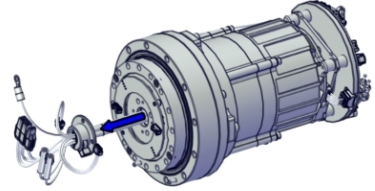
Continued

	Action	Note
7	Remove the cable plate by removing the attachment screws.	 xx2000002049
8	Remove the joint cable from the hollow shaft from the torque sensor side.  CAUTION The connectors and the joint unit cables are sensitive to mechanical damage. Handle the assembly with care.	 xx2000002060

Refitting the joint cabling

Use these procedures to refit the joint-3 cabling.

Refitting the joint cable

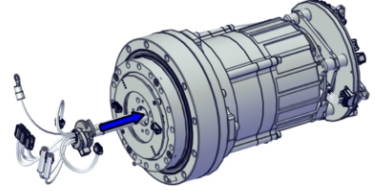
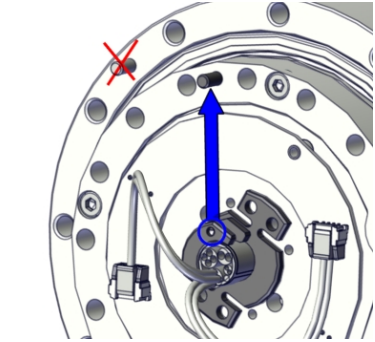
	Action	Note
1	 ELECTROSTATIC DISCHARGE (ESD) The unit is sensitive to ESD. Before handling the unit read the safety information in section The unit is sensitive to ESD on page 53 .	
2	Place the joint cable through the hollow shaft from the torque sensor side.  CAUTION The connectors and the joint unit cables are sensitive to mechanical damage. Handle the assembly with care.	 xx2000002048
3	Orient the cable plate according to the figure. The circle on the cable plate should point towards the guide pin on the torque sensor.	 xx2000002051

Continues on next page

5.3.4 Replacing the axis-3 cabling
Continued

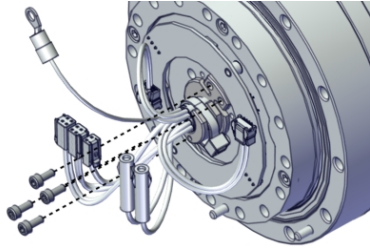
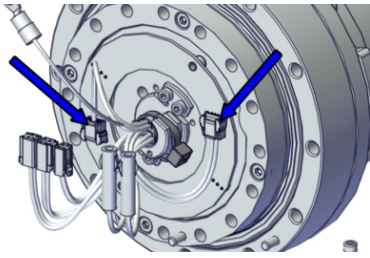
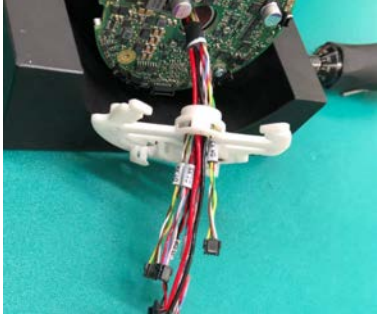
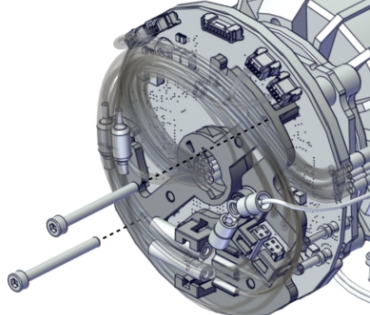
	Action	Note
4	Secure the cable plate to the joint unit with the attachment screws.	<p>Hex socket head cap screw: M2.5x6 12.9 Lafre 2C2B/FC6.9 (4 pcs) Tightening torque: 0.45 Nm.</p>  <p>xx2000002049</p>
5	<p>Connect the two connectors to the torque sensor board.</p> <ul style="list-style-type: none"> • TQ.A to CH1/A • TQ.B to CH2/B 	 <p>xx2000002053</p>
6	Insert the cabling through the cable support and fit the support to the drive board with the attachment screws.	 <p>xx2000002056</p> <p>Hex socket head cap screw: M3x30 12.9 Lafre 2C2B/FC6.9 (2 pcs) Tightening torque: 0.45 Nm.</p>  <p>xx2000002055</p>

Continues on next page

5 Repair

5.3.4 Replacing the axis-3 cabling

Continued

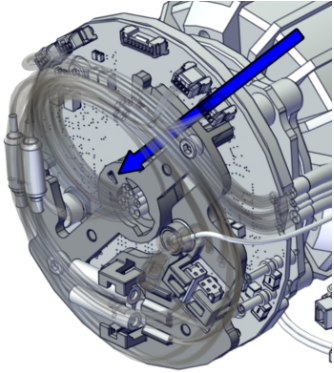
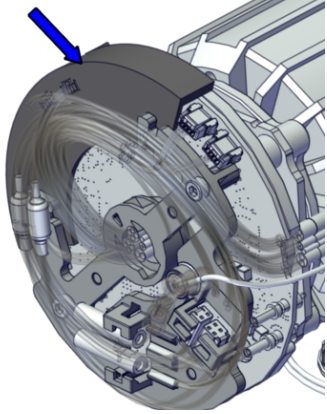
	Action	Note
7	Keep the cabling loose, making sure not to twist or strain it. Use the cable tie to pre-fix the cable by hand.	 xx2100000507
8	Fit the protection plate to the drive board unit.	Protection plate: 3HAC077790-001 (for CRB 15000-5/0.95) / 3HAC087789-001 (for CRB 15000-10/1.52 and CRB 15000-12/1.27)  xx2000002057

Continues on next page

5.3.4 Replacing the axis-3 cabling
Continued

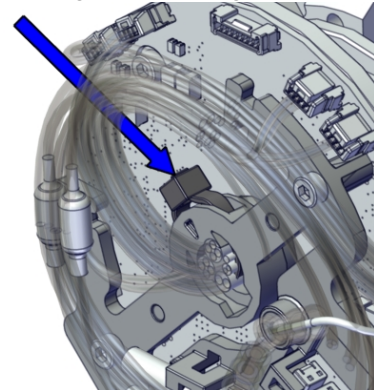
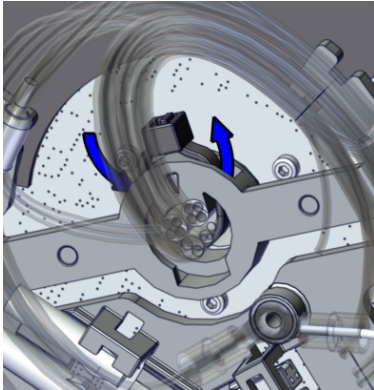
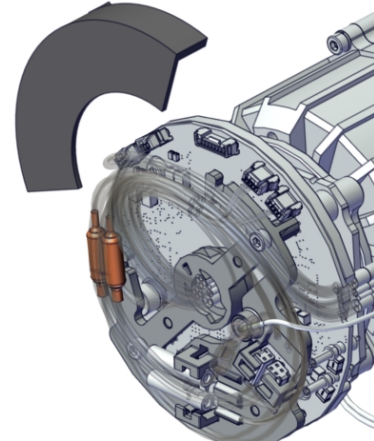
	Action	Note
9	<p>Secure the cables to the cable support with a cable tie, using a cable tie gun.</p> <p>Assembly direction for the cable tie is shown in the figure.</p>	<p>Cable tie: 3HAC075545-001. For securing joint unit cable.</p> <p>Cable tie gun EVO 7i</p> <p>Settiing for cable tie gun: 6.75.</p>  <p>xx2000002058</p>  <p>xx2000002059</p>
10	<p>Remove the protection plate.</p>	 <p>xx2100000301</p>



Continues on next page

5 Repair

5.3.4 Replacing the axis-3 cabling

Continued

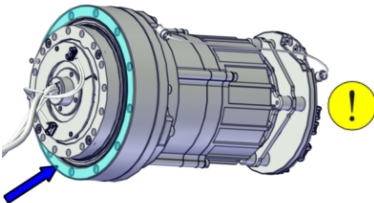

Preparations before fitting the joint unit (-5/0.95)

	Action	Note
1	 ELECTROSTATIC DISCHARGE (ESD) The unit is sensitive to ESD. Before handling the unit read the safety information in section <i>The unit is sensitive to ESD on page 53</i> .	
2	Clean the mounting surface of the joint unit and the mating surface on the casting with isopropanol. Joint unit mounting surface is pointed out in the figure.	Cleaning agent: Isopropanol Flange sealant: Loctite 574
3	Apply a thin layer of flange sealant to the mounting surface. Do not contaminate the radial sealing with sealant.  CAUTION The connectors and the joint unit cables are sensitive to mechanical damage. Handle the assembly with care.  ELECTROSTATIC DISCHARGE (ESD) The unit is sensitive to ESD. Before handling the unit read the safety information in section <i>The unit is sensitive to ESD on page 53</i> .	 xx2000001860

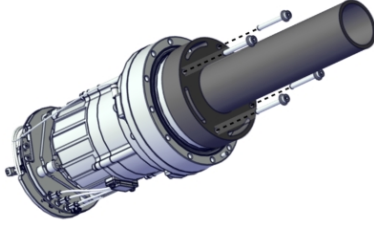
Refitting the axis-3 joint unit (-5/0.95)

	Action	Note
1	Fit the lifting aid to the joint unit.  CAUTION The connectors and the joint unit cables are sensitive to mechanical damage. Handle the assembly with care.	Joint unit: 3HAC079141-001 Lifting aid: 3HAC077788-001 Screws: M4x35 (4 pcs)  xx2000001957

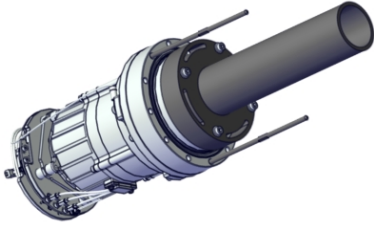
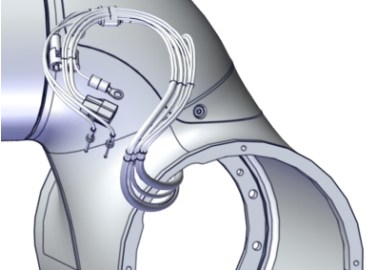
Continues on next page

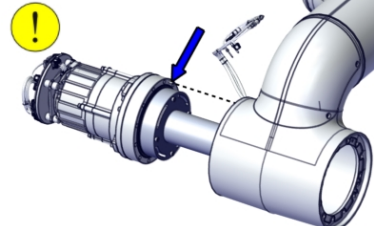
	Action	Note
2	Fit two guide pins to the joint unit.	<p>Guide pin, M4x120: 3HAC077786-001</p> <p>Always use guide pins in pairs.</p> <p>For joint units on axes 1, 2 and 3 of CRB 15000-5/0.95 and axis 3 of CRB 15000-10/1.52 and CRB 15000-12/1.27.</p>  <p>xx2000002438</p>
3	Place the cabling at the slot before refitting the joint unit.	 <p>xx2100000004</p>
4	<p>Fit the joint unit to the housing, aligning the pin with the pin hole.</p> <p> CAUTION</p> <p>The connectors and the joint unit cables are sensitive to mechanical damage. Handle the assembly with care.</p>	 <p>xx2000002072</p>

Continues on next page

5 Repair

5.3.4 Replacing the axis-3 cabling

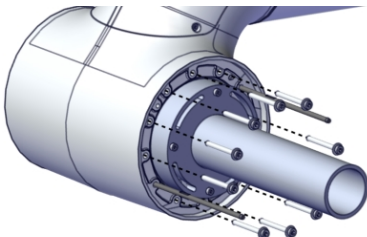
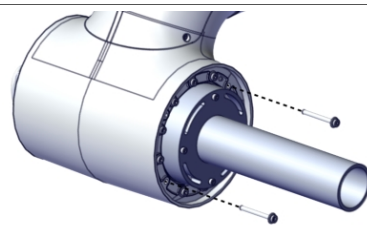
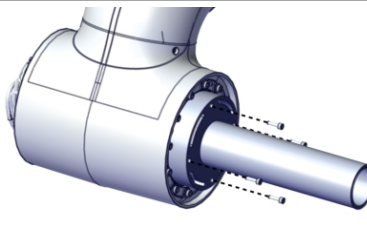

Continued

	Action	Note
5	Secure the joint unit with new attachment screws.	<p>Flange socket head screw with glue: 3HAB3413-435 M4x35 12.9 Lafre 2C2B/FC6.9+PrO-COat111, with NYPLAS glue , 12 pcs Used for joint unit of CRB 15000-5/0.95.</p> <p>Always use new screws when refitting a joint unit. If ordering a new joint unit spare part, new screws are included.</p>  <p>xx2100000320</p>
6	Remove the guide pins and secure the remaining two attachment screws.	 <p>xx2000002070</p>
7	Pre-tighten the screws crosswise.	
8	Torque tighten all screws crosswise.	Tightening torque: 4.3 Nm.
9	Remove the lifting aid by removing the screws.	 <p>xx2000002069</p>
10	Clean pushed-out flange sealant, if any.	

Refitting the axis-3 joint unit (-10/1.52 and -12/1.27)

	Action	Note
1	 <p>ELECTROSTATIC DISCHARGE (ESD)</p> <p>The unit is sensitive to ESD. Before handling the unit read the safety information in section The unit is sensitive to ESD on page 53.</p>	

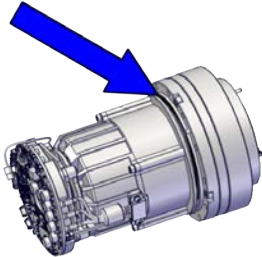
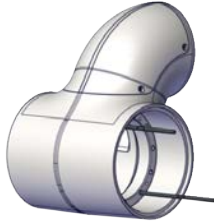
Continues on next page

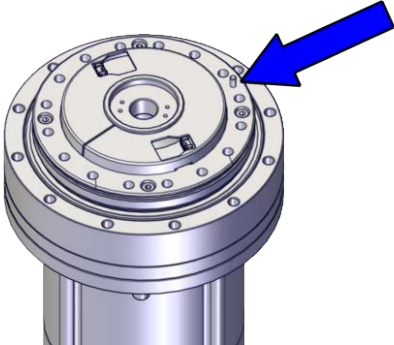
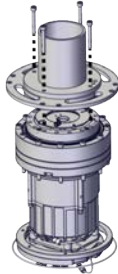
	Action	Note
2	<p>Check the o-ring. Replace if damaged.</p>	<p>O-ring: 3HAC061327-036</p>  <p>xx2300000836</p>
3	<p>Fit two guide pins to the housing.</p>	<p>Guide pin, M4x120: 3HAC077786-001 Always use guide pins in pairs. For joint units on axes 1, 2 and 3 of CRB 15000-5/0.95 and axis 3 of CRB 15000-10/1.52 and CRB 15000-12/1.27.</p>  <p>xx2300000803</p>
4	<p>Fit the lifting aid to the joint unit, aligning the pin with the pin hole.</p> <p> CAUTION</p> <p>The connectors and the joint unit cables are sensitive to mechanical damage. Handle the assembly with care.</p>  <p>xx2300000777</p>	<p>Joint unit: 3HAC087474-001 Lifting aid: 3HAC087788-001 Screws: M4x30 (4 pcs)</p>  <p>xx2300000804</p>

Continues on next page

5 Repair

5.3.4 Replacing the axis-3 cabling

Continued

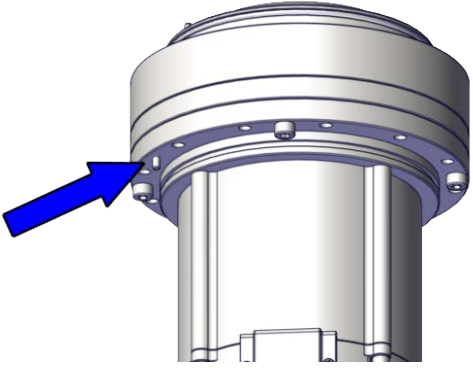
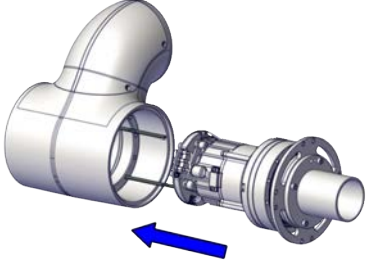
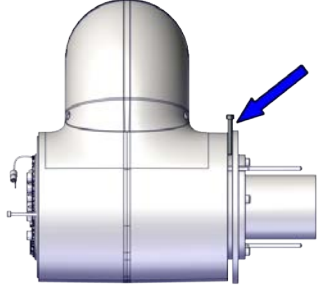
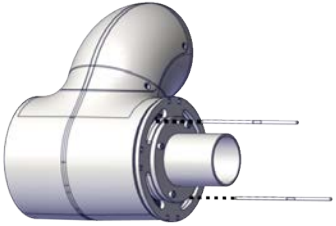
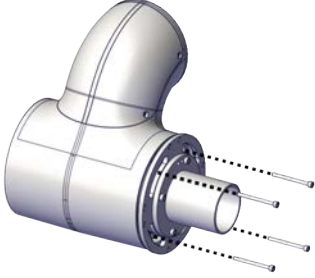
	Action	Note
5	<p>Fit the joint unit to the housing, aligning the pin with the pin hole.</p> <p> CAUTION</p> <p>The connectors and the joint unit cables are sensitive to mechanical damage. Handle the assembly with care.</p>  <p>xx230000780</p>	 <p>xx230000806</p>
6	<p>Check the joint unit position by placing an M4 screw between the lifting aid and housing. The joint unit is properly placed when no gaps between the lifting aid and housing.</p>	 <p>xx230000808</p>
7	<p>Remove the guide pins.</p>	 <p>xx230000809</p>
8	<p>Secure with four attachment screws and pre-tighten the screws crosswise.</p>	 <p>xx230000810</p>

Continues on next page

5.3.4 Replacing the axis-3 cabling
Continued

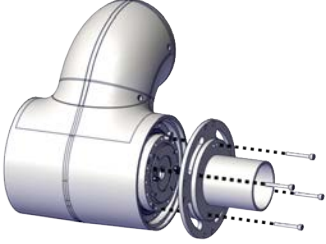
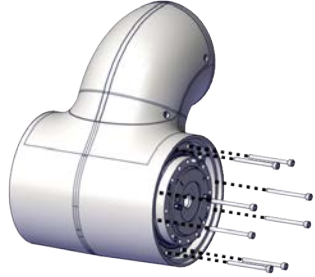
	Action	Note
9	Remove the lifting aid by removing the screws.	 <p>xx2300000800</p>
10	Secure the joint unit with the remaining attachment screws.	<p>Hex socket head cap screw: 3HAB3409-262</p>  <p>xx2300000811</p>
11	Torque tighten all screws crosswise.	<p>M4x45 12.9 Lafre 2C2B/FC6.9, 12 pcs Tightening torque: 4.3 Nm.</p>

Connecting the axis-3 joint unit cabling

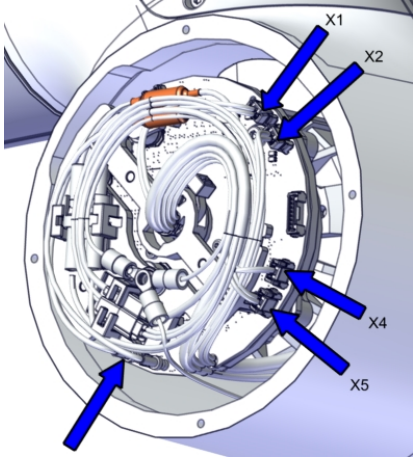
	Action	Note
1	<p>Reconnect the connectors to the drive board.</p> <ul style="list-style-type: none"> • D3.X1 to X1 • D3/4.DC+ to DC+ • D3/4.DC- to Ground • D3.X4 to X4 • D3/4.X2 to X2 • D3.X5 to X5 	 <p>xx2000002068</p>

Continues on next page

5 Repair

5.3.4 Replacing the axis-3 cabling

Continued

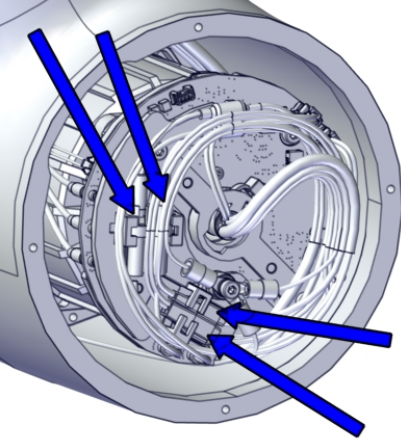
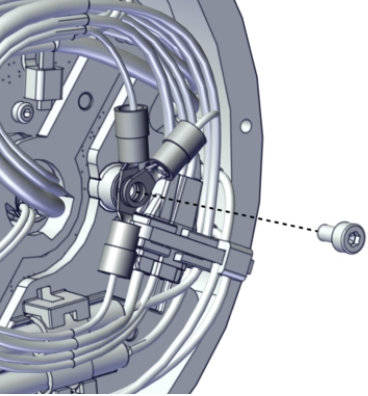
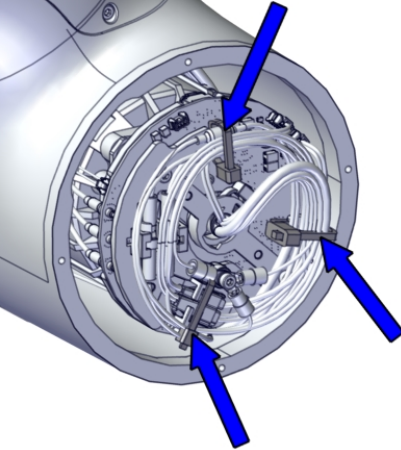
	Action	Note
2	<p>Connect the connectors to each other and snap them to the cable holders.</p> <ul style="list-style-type: none">• J4.DC+ to J4/5.DC+• J4.DC- to J4/5.DC-• J4.CS to J4/5.CS• J4.CP to J4/5.CP	 <p>xx2000002067</p>
3	<p>Secure the cables for functional earth and protective earth with a screw.</p>	<p>Hex socket head cap screw: M3x6 (1 pcs). Tightening torque: 0.8 Nm.</p>  <p>xx2000001945</p>
4	<p>Secure the cabling with cable ties.</p>	<p>Cable ties (3 pcs)</p>  <p>xx2000002066</p>

Continues on next page

Refitting the housing cover (-5/0.95)

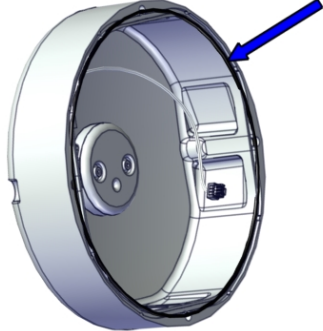
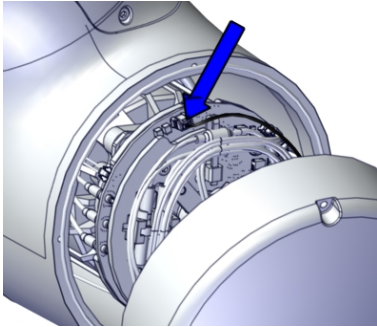
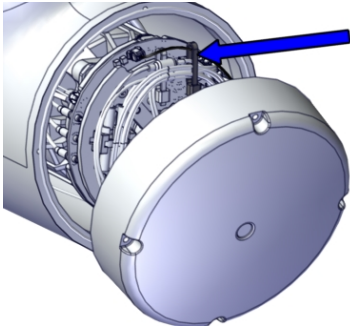
	Action	Note
1	Fit the o-ring to its groove. Replace if damaged.	<p>O-ring: 3HAC061327-047</p>  <p>xx2000001962</p>
2	<p>For robots with RobotWare earlier than 7.10 Place the cover at mounting position and reconnect the brake release connector DR.X8 to the drive board. Orient the cover for proper arrangement of the brake release cable.</p>	 <p>xx2000002023</p>
3	<p>For robots with RobotWare earlier than 7.10 Secure the brake release cable with a cable tie.</p>	<p>Cable ties</p>  <p>xx2000002022</p>

Continues on next page



5 Repair

5.3.4 Replacing the axis-3 cabling

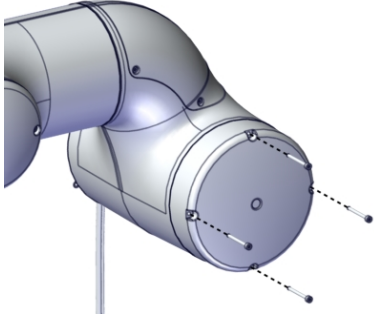
Continued

	Action	Note
4	Refit the cover with the four screws.	<p>Hex socket head cap screw: M3x30 12.9 Lafre 2C2B/FC6.9 (4 pcs) Tightening torque: 0.45 Nm</p>  <p>xx2000002021</p>

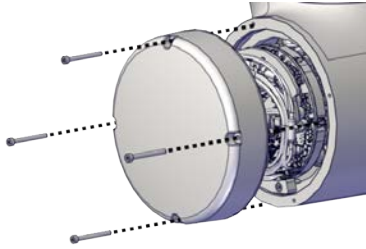
Removing the housing cover and insert (-10/1.52 and -12/1.27)

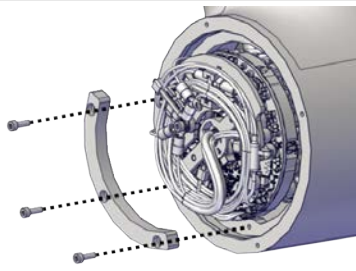
	Action	Note
1	 CAUTION Make sure that all supplies for electrical power are turned off.	
2	Remove the cover by removing the screws.	 <p>xx2300000833</p>
3	 CAUTION Valid for CRB 15000-5/0.95 There is cabling connected between the cover and the joint unit drive board. Open the cover with care to avoid damage to the cabling or the connector(s). Do not leave the cover in location without being secured with the attachment screws.	
4	Remove the insert.	 <p>xx2300000834</p>

Continues on next page

Refitting the upper arm

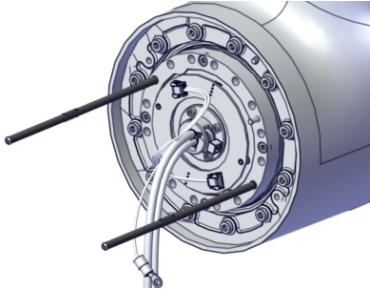
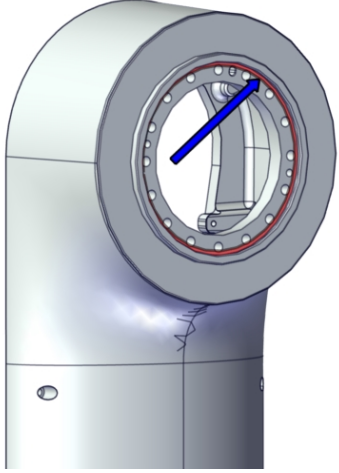
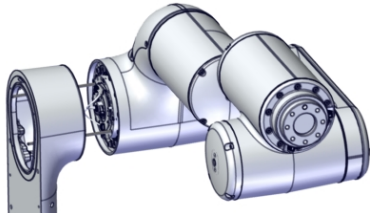
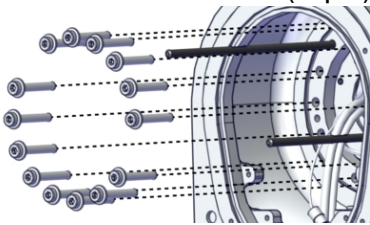
	Action	Note
1	Fit two guide pins to the axis-3 joint.	<p>Guide pin, M4x120: 3HAC077786-001</p>  <p>xx2000001971</p>
2	<p>Valid for CRB 15000-5/0.95</p> <p>Clean the mounting surface with isopropanol.</p> <p>Apply flange sealant to the corner of the lower arm mounting surface, as pointed out in the figure.</p>	<p>Cleaning agent: Isopropanol Flange sealant: Loctite 574</p>  <p>xx2000001973</p>
3	Lift the upper arm into mounting position while inserting the cabling into the lower arm.	 <p>xx2000001970</p>
4	Slide the upper arm into place on the guide pins.	
5	<p>Secure the upper arm to the lower arm with all attachment screws but two.</p> <p>Pre-tighten the screws crosswise firstly.</p>	<p>Hex socket head cap flange screw: M4x25 12.9 Lafre 2C2B/FC6.9+PrO-COat111 (16 pcs)</p>  <p>xx2000001969</p>

Continues on next page

5 Repair

5.3.4 Replacing the axis-3 cabling

Continued

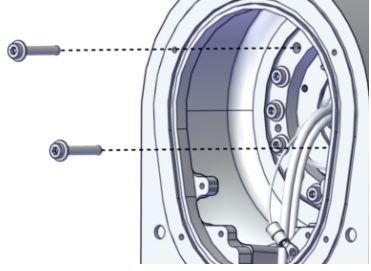
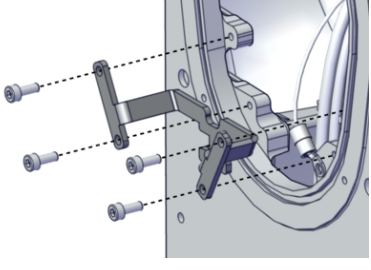
	Action	Note
6	Remove the guide pins and fasten the remaining two screws.	<p>Hex socket head cap flange screw: M4x25 12.9 Lafre 2C2B/FC6.9+PrO-COat111 (16 pcs)</p>  <p>xx2000001967</p>
7	Torque tighten all screws crosswise.	Tightening torque: 4.6 Nm
8	Refit the cable bracket with the four screws.	<p>Hex socket head cap screw: M3x8 12.9 Lafre 2C2B/FC6.9 (4 pcs). Tightening torque: 0.8 Nm</p>  <p>xx2000001966</p>

Fastening the cabling between the lower and upper arm

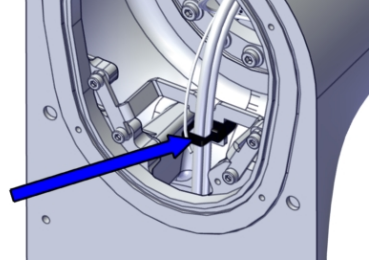
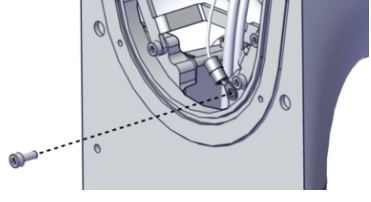
	Action	Note
1	Secure the cabling with the cable tie.	<p>Cable ties</p>  <p>xx2000001965</p>
2	Connect the functional earth cable with the screw.	<p>Hex socket head cap screw: M3x8 12.9 Lafre 2C2B/FC6.9 (1 pcs). Tightening torque: 0.8 Nm</p>  <p>xx2000001964</p>

Continues on next page

Connecting the upper arm cabling

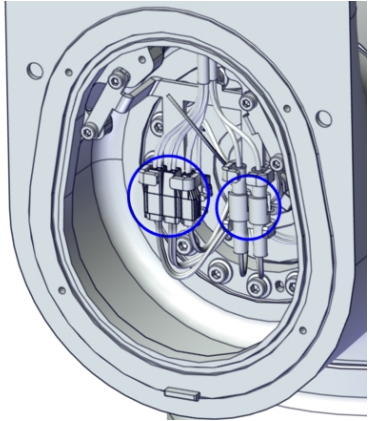
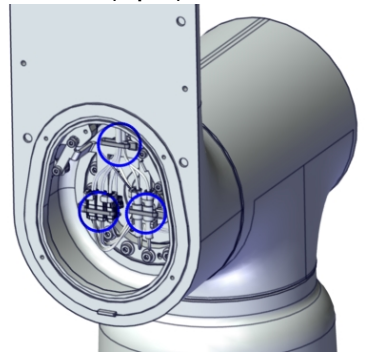
	Action	Note
1	Connect the connectors to each other and snap them to the cable holders.	 <p>xx2000001938</p>
2	Secure the cabling with cable ties.	<p>Cable ties (3 pcs)</p>  <p>xx2000001937</p>



Continues on next page

5 Repair

5.3.4 Replacing the axis-3 cabling

Continued

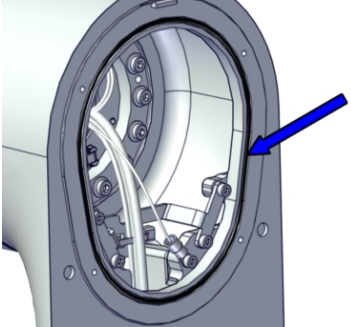
Refitting the lower arm covers (-5/0.95)

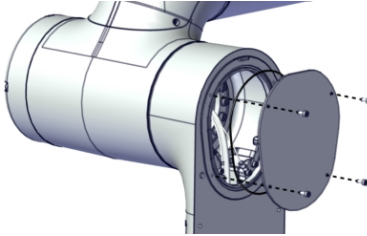
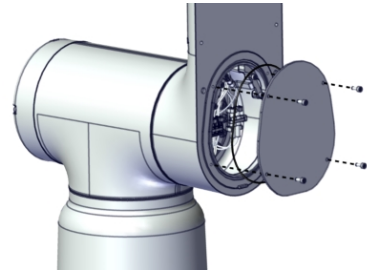
	Action	Note
1	Wipe, lubricate and fit the o-ring to its groove. Replace if damaged.	<p>O-ring: 3HAC061327-044 Grease: 3HAC042536-001 (Shell Gadus S2)</p>  <p>xx2000001955</p>  <p>xx2000001954</p>
2	Refit the inner covers with four screws each.	<p>Hex socket head cap screw: M3x8 12.9 Lafre 2C2B/FC6.9 (8 pcs) Tightening torque: 1.4 Nm.</p>  <p>xx2000001947</p>  <p>xx2000001930</p>

Continues on next page

5.3.4 Replacing the axis-3 cabling
Continued

	Action	Note
3	Snap the lower arm cover into place.	Hex socket head cap screw: M3x16 12.9 Lafre 2C2B/FC6.9 (4 pcs) Tightening torque: 0.45 Nm.
4	Secure the cover with four screws.	

xx2000001929

Refitting the lower arm covers (-10/1.52 and -12/1.27)

	Action	Note
1	Wipe, lubricate and fit the o-ring to its groove. Replace if damaged.	<p>O-ring: 3HAC061327-075 O-ring: 3HAC061327-044 Grease: 3HAC042536-001 (Shell Gadus S2)</p> <div data-bbox="1058 1205 1390 1473" style="text-align: right;"> </div> <p data-bbox="1058 1480 1166 1498" style="text-align: right;">xx2300000832</p> <div data-bbox="1058 1520 1390 1789" style="text-align: right;"> </div> <p data-bbox="1058 1796 1166 1814" style="text-align: right;">xx2300000831</p>

Continues on next page

5 Repair

5.3.4 Replacing the axis-3 cabling

Continued

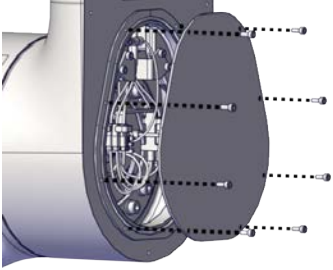
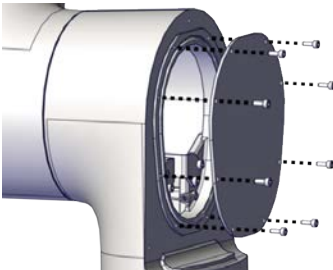
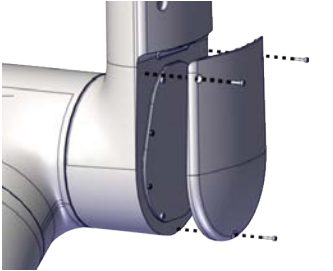
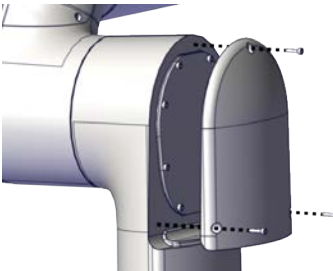
	Action	Note
2	Refit the inner covers with eight screws each.	<p>Hex socket head cap screw: M3x8 12.9 Lafre 2C2B/FC6.9 (8 pcs) x 2 Tightening torque: 1.4 Nm.</p>  <p>xx2300000813</p>  <p>xx2300000830</p>
3	Snap the lower arm cover into place.	<p>Hex socket head cap screw: M3x12 12.9 Lafre 2C2B/FC6.9 (3 pcs) x 2 Tightening torque: 1.4 Nm.</p>  <p>xx2300000812</p>  <p>xx2300000829</p>
4	Secure the cover with three screws.	

Continues on next page

Concluding procedure

	Action	Note
1	<p>Calibrate the joint unit torque sensor.</p> <ol style="list-style-type: none"> 1 On the FlexPendant, go to the Code app and call the calibration procedure using PP to Routine, not by using Call Routine. 2 Select the Joint Unit Replacement feature and then select the axis to calibrate. 3 The controller is now restarted. Once the home screen of the FlexPendant is shown, press the Play button to continue the calibration routine. 4 The robot moves to a position or positions where measurements are performed. 5 The results of the measurements are presented together with the current values in the controller. Choose whether to save the calibration data or not. 6 If new calibration data is saved you will be asked to do a test with the lead-through functionality active to verify that the sensors work correctly. 7 Finally the robot is moved back to the original position. 8 Test the brake release (movement without drive power) functionality, see Testing the brake release functionality on page 196. 	See Calibration on page 1063
2	<p> DANGER</p> <p>Make sure all safety requirements are met when performing the first test run. See Test run after installation, maintenance, or repair on page 90.</p>	

5 Repair

5.3.5 Replacing the axis-4 cabling

5.3.5 Replacing the axis-4 cabling

Location of the cable harness

The cable harness is located as shown in the figure.



xx210000060

Summary of the replacement procedure

This is a brief summary of the replacement procedure, containing the major actions to be performed.

- 1 Separate the cabling between the housing and the tubular (at the axis-3 joint unit).
- 2 Remove the tubular and place on a workbench.
- 3 Remove the axis-4 cover.
- 4 Remove the axis-4 joint unit.
- 5 Replace the cabling.

Required spare parts



Note

The spare part numbers that are listed in the table can be out of date. See the latest spare parts of the CRB 15000 via myABB Business Portal, www.abb.com/myABB.

Continues on next page

5.3.5 Replacing the axis-4 cabling
Continued

Spare part	Article number	Note
Cable harness, joint 4	3HAC073206-001	Used for CRB 15000-5/0.95. Also order new Cable tie: 3HAC075545-001.
Cable harness, joint 4	3HAC080961-001	Used for CRB 15000-10/1.52 and CRB 15000-12/1.27. Also order new Cable tie: 3HAC075545-001.
Cable tie	3HAC075545-001	For securing joint unit cable.

Required tools and equipment

Equipment	Article number	Note
Lifting aid	3HAC077789-001	For joint units on axes 4, 5 and 6. Attachment screws M3x12 (4 pcs) are enclosed.
Guide pin, M3x110	3HAC077787-001	Always use guide pins in pairs. For joint units on axes 4, 5 and 6.
Tweezers	-	Used to handle drive board con- nectors.
Protection plate	3HAC077790-001	For protection of drive board during cabling installation on joint units of CRB 15000-5/0.95.
Cable tie gun EVO 7i	-	HellermannTyton 110-77001 or similar
Standard toolkit	-	Content is defined in section Standard toolkit on page 1099 .

Required consumables

Consumable	Article number	Note
Cable ties	-	
O-ring	3HAC061327-051	Axis-4 cover, used for CRB 15000-5/0.95. Replace if damaged.
O-ring	3HAC061327-051	Axis-4 cover, used for CRB 15000-10/1.52 and CRB 15000- 12/1.27. Replace if damaged.
Gasket	3HAC075056-001	Cover inside housing Replace if damaged.
O-ring	3HAC061327-047	Cover for axis 2/3, used for CRB 15000-5/0.95. Replace if damaged.
O-ring	3HAC061327-047	Housing cover, used for CRB 15000-10/1.52 and CRB 15000- 12/1.27. Replace if damaged.

Continues on next page

5 Repair

5.3.5 Replacing the axis-4 cabling

Continued

Consumable	Article number	Note
O-ring	3HAC061327-043	Tubular cover, used for CRB 15000-5/0.95. Replace if damaged.
O-ring	3HAB3772-166	Tubular cover, upper, used for CRB 15000-10/1.52 and CRB 15000-12/1.27. Replace if damaged.
O-ring	3HAC061327-076	Tubular cover, lower, used for CRB 15000-10/1.52 and CRB 15000-12/1.27. Replace if damaged.
Flange socket head screw with glue	3HAB3413-312	M3x12 12.9 Lafre 2C2B/FC6.9+PrO-COat111, with NYPLAS glue For tubular cover of CRB 15000-5/0.95. Always use new screws. If ordering a new axis-4 or axis-5 joint unit spare part, new screws for the tubular cover are included.
Cleaning agent	-	Isopropanol
Flange sealant	-	Loctite 574

Removing the joint cabling

Use these procedures to remove the joint-4 cabling.

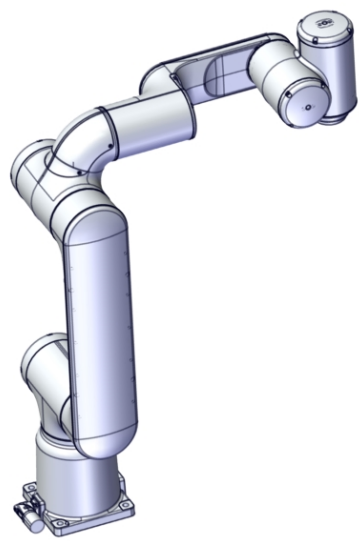

Preparations before removing the cabling

	Action	Note
1	<p>Jog the robot to the specified position:</p> <ul style="list-style-type: none"> • Axis 1: No significance. • Axis 2: 0° • Axis 3: 0° • Axis 4: 0° (home position) • Axis 5: +90° • Axis 6: No significance. <p> CAUTION</p> <p>Jog the axis on which the joint unit is to be replaced to home position, to achieve correct cable routing during replacement of the joint unit.</p>	<p>Example of CRB 15000-5/0.95, similar to CRB 15000-10/1.52 and CRB 15000-12/1.27.</p>  <p>xx210000005</p>

Continues on next page

	Action	Note
2	 CAUTION Turn off all supplies for electrical power to the robot, before starting the repair work.	

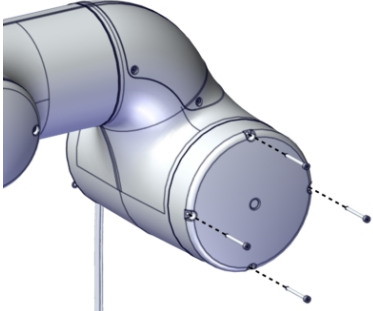
Removing the housing cover (-5/0.95)

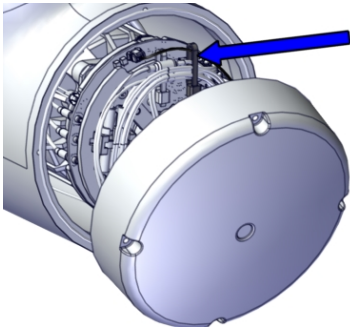
	Action	Note
1	 CAUTION Make sure that all supplies for electrical power are turned off.	
2	Remove the cover screws.	 xx2000002021
3	 CAUTION Valid for CRB 15000-5/0.95 There is cabling connected between the cover and the joint unit drive board. Open the cover with care to avoid damage to the cabling or the connector(s). Do not leave the cover in location without being secured with the attachment screws.	
4	For robots with RobotWare earlier than 7.10 Open the cover and cut the cable tie that holds the brake release cable.	 xx2000002022

Continues on next page



5 Repair

5.3.5 Replacing the axis-4 cabling

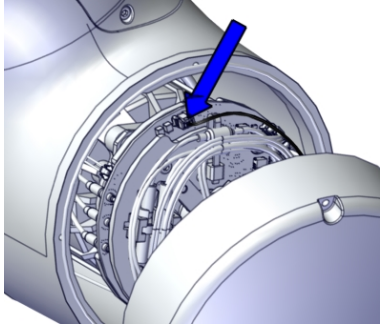
Continued

	Action	Note
5	<p>For robots with RobotWare earlier than 7.10 Disconnect the brake release connector DR.X8 from the drive board. Remove the cover.</p>	 <p>xx2000002023</p>

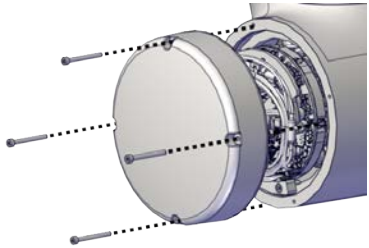
Removing the housing cover and insert (-10/1.52 and -12/1.27)

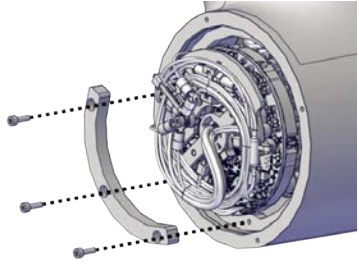
	Action	Note
1	 CAUTION Make sure that all supplies for electrical power are turned off.	
2	Remove the cover by removing the screws.	 <p>xx2300000833</p>
3	 CAUTION Valid for CRB 15000-5/0.95 There is cabling connected between the cover and the joint unit drive board. Open the cover with care to avoid damage to the cabling or the connector(s). Do not leave the cover in location without being secured with the attachment screws.	
4	Remove the insert.	 <p>xx2300000834</p>

Continues on next page

Separating the cabling between the housing and the tubular

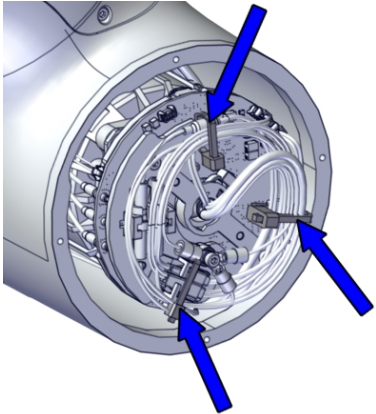
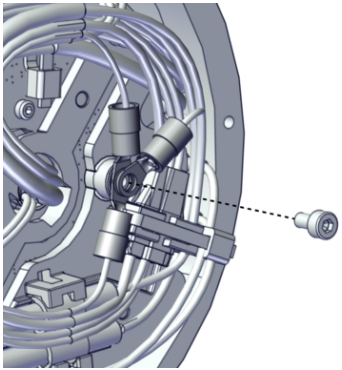
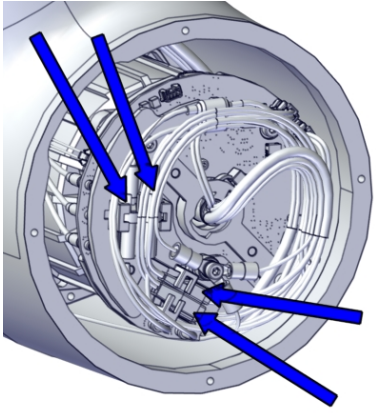
	Action	Note
1	Cut the cable ties.	 <p>xx2000002066</p>
2	Remove the functional and protective earth cables by removing the screw.	 <p>xx2000001945</p>
3	Snap loose and disconnect the connectors: <ul style="list-style-type: none"> • J4/5.DC+ • J4/5.DC- • J4/5.CS • J4/5.CP 	 <p>xx2000002067</p>

Continues on next page

5 Repair

5.3.5 Replacing the axis-4 cabling

Continued

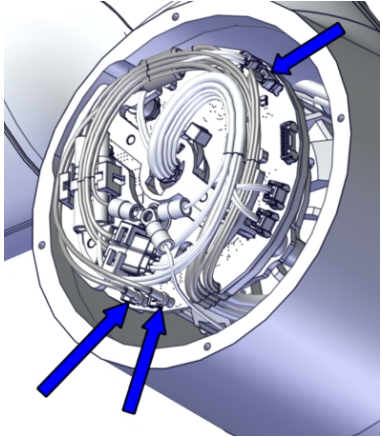
	Action	Note
4	Disconnect the connectors from the drive board. <ul style="list-style-type: none">• D3/4.X2• D3/4.DC+• D3/4.DC-	 <p>xx2000002120</p>

Opening the housing top cover

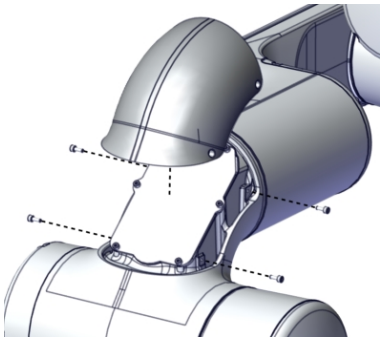
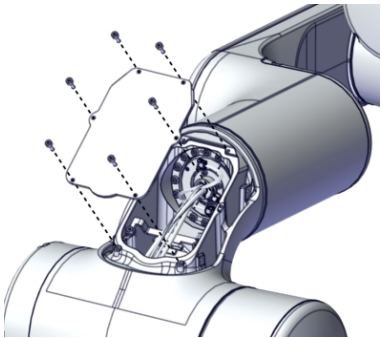
	Action	Note
1	Remove the cover by removing the four screws.	 <p>xx2000002075</p>
2	Remove the inner plate by removing the screws.	 <p>xx2000002076</p>

Continues on next page

Removing the tubular

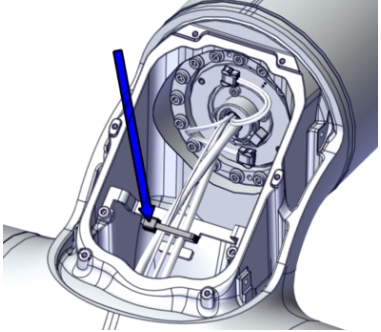
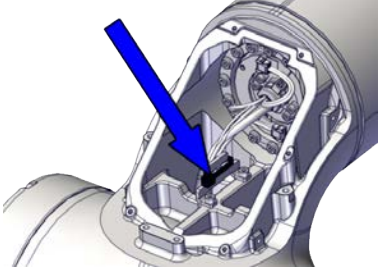
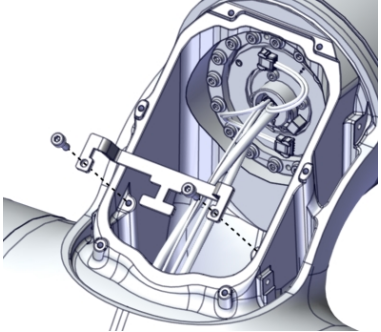
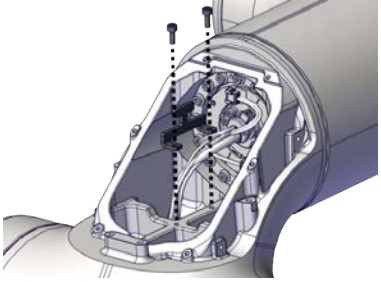
	Action	Note
1	Cut the cable tie.	<p>Valid for CRB 15000-5/0.95</p>  <p>xx2000002077</p> <p>Valid for CRB 15000-10/1.52 and CRB 15000-12/1.27</p>  <p>xx2300000839</p>
2	Remove the cable bracket by removing the two screws.	<p>Valid for CRB 15000-5/0.95</p>  <p>xx2000002078</p> <p>Valid for CRB 15000-10/1.52 and CRB 15000-12/1.27</p>  <p>xx2300000840</p>

Continues on next page

5 Repair

5.3.5 Replacing the axis-4 cabling

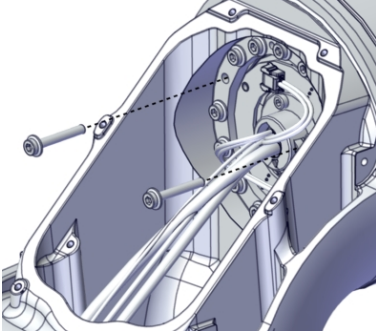
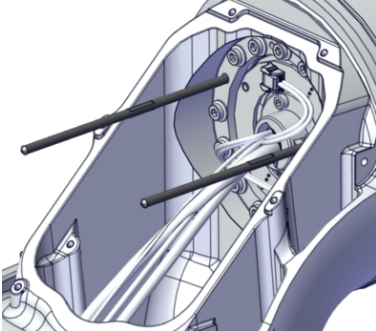
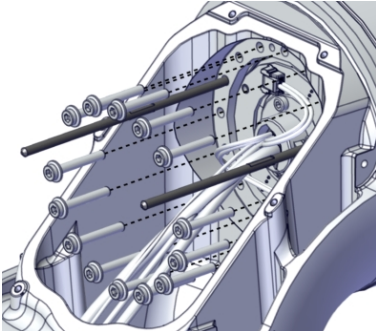
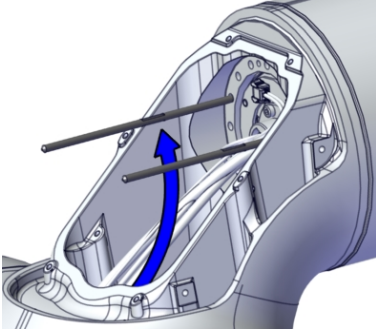

Continued

	Action	Note
3	Remove two attachment screws and fit two guide pins to the axis-4 joint unit.	<p>Guide pin, M3x110: 3HAC077787-001</p> <p>Always use guide pins in pairs.</p>  <p>xx2000002079</p>  <p>xx2000002080</p>
4	Remove the remaining attachment screws.	 <p>xx2000002081</p>
5	Pull out the cabling carefully from the housing.	 <p>xx2000002127</p>

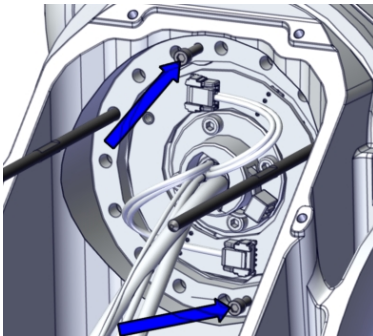
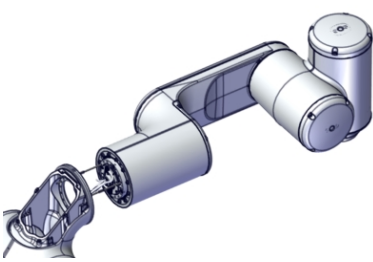
Continues on next page

	Action	Note
6	Use two fully threaded attachment screws as removal tools to press the housing out of position.	 <p>xx210000006</p>
7	Remove the tubular from the housing. Assist the cabling to be removed from the housing while lifting away the complete tubular. Place the tubular on a workbench.	 <p>xx2000002082</p>

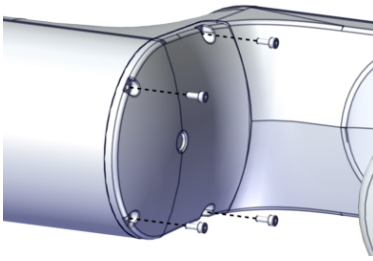
Removing the axis-4 cover

	Action	Note
1	Remove the cover screws.	 <p>xx2000002083</p>
2	<p> CAUTION</p> <p>Valid for CRB 15000-5/0.95</p> <p>There is cabling connected between the cover and the joint unit drive board.</p> <p>Open the cover with care to avoid damage to the cabling or the connector(s).</p> <p>Do not leave the cover in location without being secured with the attachment screws.</p>	

Continues on next page

5 Repair

5.3.5 Replacing the axis-4 cabling

Continued

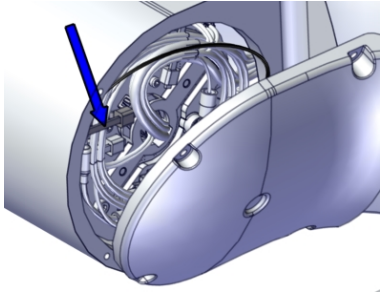
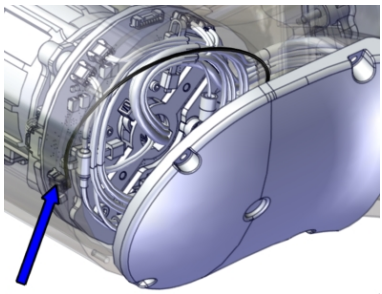
	Action	Note
3	For robots with RobotWare earlier than 7.10 Open the cover and cut the cable tie that holds the brake release cable.	 xx2000002084
4	For robots with RobotWare earlier than 7.10 Disconnect the brake release connector DR.X8 from the drive board. Remove the cover.	Tweezers  xx2000002085

Removing the tubular cover

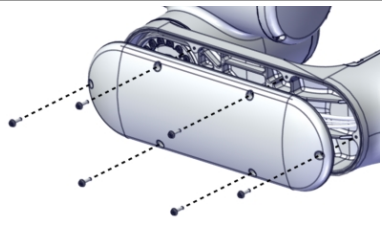
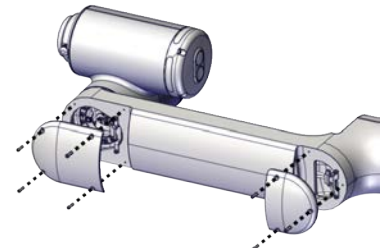
	Action	Note
1	Valid for CRB 15000-5/0.95 Remove the cover by removing the six screws. Dispose the screws. New screws must be used when refitting the cover. New screws are included in the spare part delivery of the joint unit.	 xx2000002123
2	Valid for CRB 15000-10/1.52 and CRB 15000-12/1.27 Remove the covers by removing the screws.	 xx2300000841

Continues on next page

Separating the cabling between the tubular and the tilt

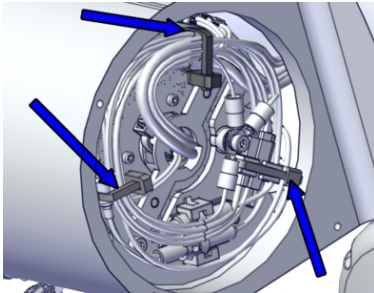
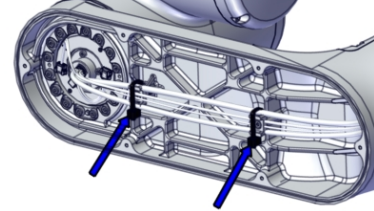
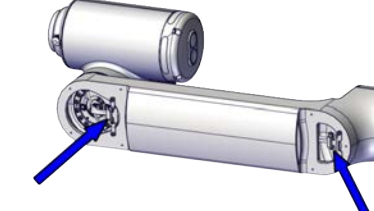
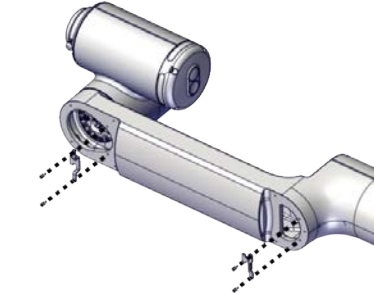
	Action	Note
1	Cut the cable ties on joint unit.	 <p>xx2000002086</p>
2	Cut the cable ties on tubular, if needed.	<p>Valid for CRB 15000-5/0.95</p>  <p>xx2000002124</p> <p>Valid for CRB 15000-10/1.52 and CRB 15000-12/1.27</p>  <p>xx2300000842</p>
3	<p>Valid for CRB 15000-10/1.52 and CRB 15000-12/1.27</p> <p>Remove the cable brackets.</p>	 <p>xx2300000843</p>

Continues on next page

5 Repair

5.3.5 Replacing the axis-4 cabling

Continued

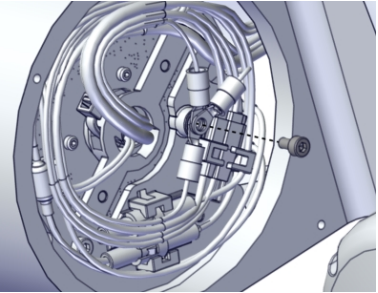
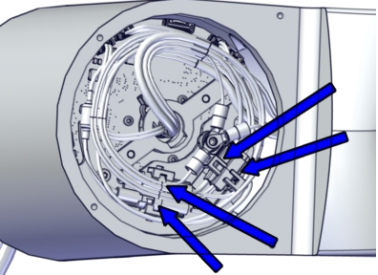
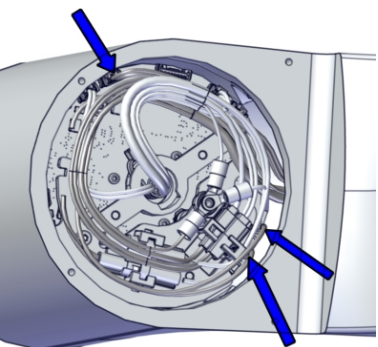
	Action	Note
4	Remove the functional and protective earth cables by removing the screw.	 xx2000002087
5	Snap loose and disconnect the connectors: <ul style="list-style-type: none">• J4/5.DC+• J4/5.DC-• J4/5.CS• J4/5.CP	 xx2000002089
6	Disconnect the connectors that belongs to the axis-5 cabling, from the axis-4 drive board: <ul style="list-style-type: none">• D3/4.X2• D3/4.DC-• D3/4.DC+ Use tweezers, if needed.	Tweezers  xx2000002125

Continues on next page

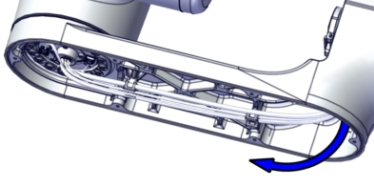
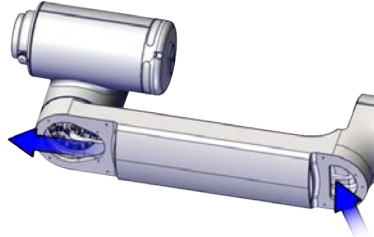
	Action	Note
7	Pull out the cabling carefully from the tubular.	<p>Valid for CRB 15000-5/0.95</p>  <p>xx2000002126</p> <p>Valid for CRB 15000-10/1.52 and CRB 15000-12/1.27</p>  <p>xx2300000844</p>

Disconnecting the axis-4 joint unit cabling

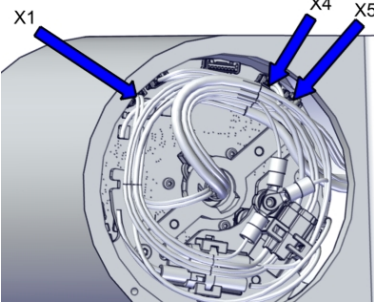
	Action	Note
1	<p>Disconnect the connectors from the drive board.</p> <p> CAUTION</p> <p>Use tweezers to unlock connectors and pull them off.</p> <ul style="list-style-type: none"> • D4/5.X1 • D4/5.X4 • D4/5.X5 	<p>Tweezers</p>  <p>xx2000002088</p>

Removing the axis-4 joint unit

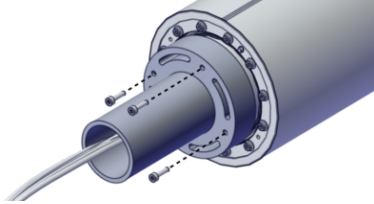

	Action	Note
1	<p>Fit the lifting aid to the joint unit, on the torque sensor side.</p> <p> CAUTION</p> <p>The connectors and the joint unit cables are sensitive to mechanical damage. Handle the assembly with care.</p>	<p>Lifting aid: 3HAC077789-001 Screws: M3x12 (4 pcs)</p>  <p>xx2000002090</p>

Continues on next page

5 Repair

5.3.5 Replacing the axis-4 cabling

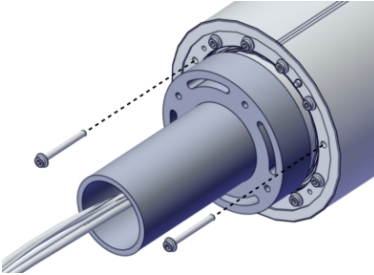
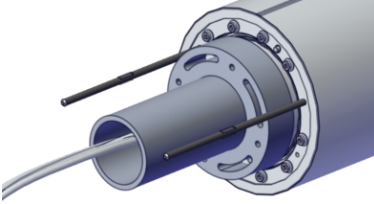
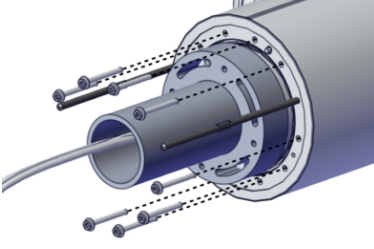
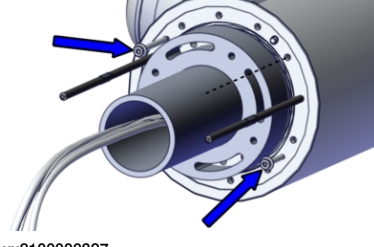

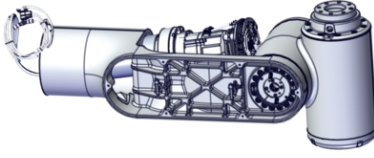
Continued

	Action	Note
2	<p>Remove two attachment screws. Dispose the screws. New screws are included in the spare part delivery of the joint unit.</p>	 <p>xx2000002091</p>
3	<p>Fit two guide pins to the axis-4 joint unit.</p>	<p>Guide pin, M3x110: 3HAC077787-001 Always use guide pins in pairs. For joint units on axes 4, 5 and 6.</p>  <p>xx2000002578</p>
4	<p>Remove the remaining attachment screws. Use two screws as press out screws in the upcoming step, then dispose all screws. New screws are included in the spare part delivery of the joint unit.</p>	 <p>xx2100000326</p>
5	<p>Press the joint unit out of position using two of the previous attachment screws as removal tools.</p>	 <p>xx2100000327</p>
6	<p>Remove the joint unit from the tubular.</p> <p> CAUTION</p> <p>The connectors and the joint unit cables are sensitive to mechanical damage. Handle the assembly with care.</p>	 <p>xx2000002116</p>

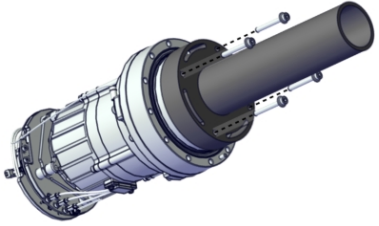
Continues on next page

	Action	Note
7	Remove the lifting aid and guide pins.	 <p>xx2000001957</p>

Removing the joint cable

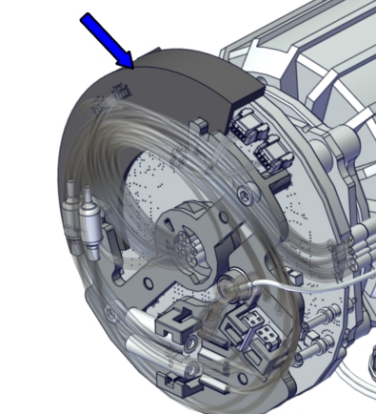
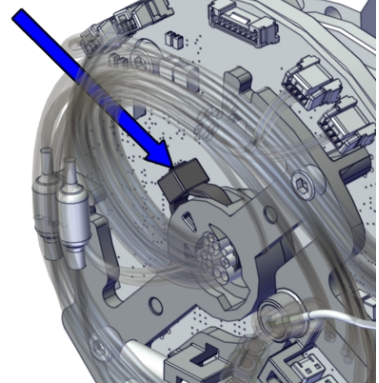
	Action	Note
1	 <p>ELECTROSTATIC DISCHARGE (ESD)</p> <p>The unit is sensitive to ESD. Before handling the unit read the safety information in section The unit is sensitive to ESD on page 53.</p>	
2	<p>Fit the protection plate to the drive board unit.</p>  <p>Tip</p> <p>Using the protection plate is important for protecting the drive board unit. If complete joint unit is to be replaced, the protection plate is not needed.</p>	<p>Protection plate: 3HAC077790-001 (for CRB 15000-5/0.95) / 3HAC087789-001 (for CRB 15000-10/1.52 and CRB 15000-12/1.27)</p>  <p>xx2000002057</p>
3	Cut the cable tie at the drive board.	 <p>xx2000002058</p>

Continues on next page

5 Repair

5.3.5 Replacing the axis-4 cabling

Continued

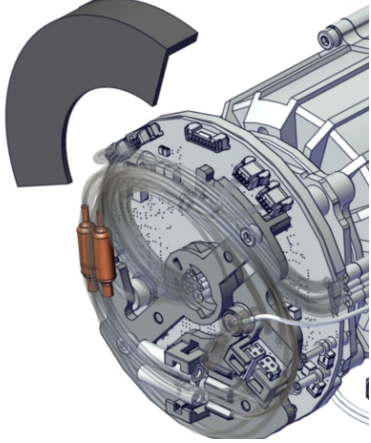
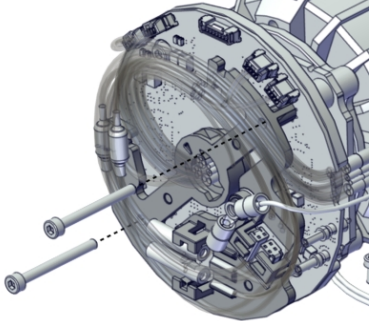
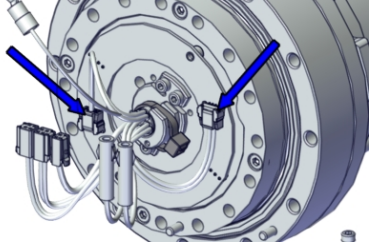
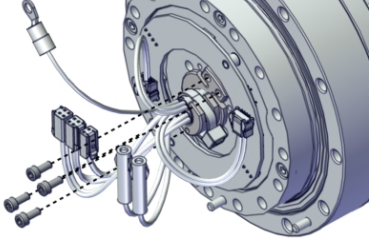
	Action	Note
4	Remove the protection plate.	 xx2100000301
5	Remove the cable support from the drive board by removing the attachment screws.	 xx2000002055
6	Disconnect the two connectors from the torque sensor board. <ul style="list-style-type: none">• TQ.A• TQ.B	 xx2000002053
7	Remove the cable plate by removing the attachment screws.	 xx2000002049

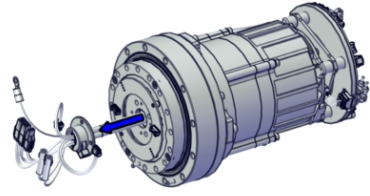

Continues on next page

	Action	Note
8	<p>Remove the joint cable from the hollow shaft from the torque sensor side.</p> <p> CAUTION</p> <p>The connectors and the joint unit cables are sensitive to mechanical damage. Handle the assembly with care.</p>	 <p>xx2000002060</p>

Refitting the joint cabling

Use these procedures to refit the joint-4 cabling.

Refitting the joint cable

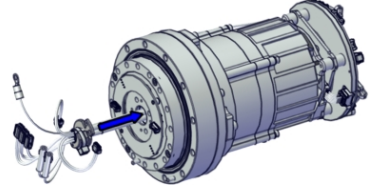
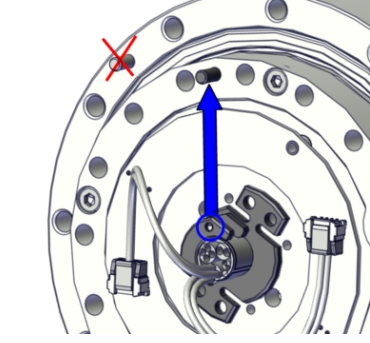
	Action	Note
1	<p> ELECTROSTATIC DISCHARGE (ESD)</p> <p>The unit is sensitive to ESD. Before handling the unit read the safety information in section The unit is sensitive to ESD on page 53.</p>	
2	<p>Place the joint cable through the hollow shaft from the torque sensor side.</p> <p> CAUTION</p> <p>The connectors and the joint unit cables are sensitive to mechanical damage. Handle the assembly with care.</p>	 <p>xx2000002048</p>
3	<p>Orient the cable plate according to the figure. The circle on the cable plate should point towards the guide pin on the torque sensor.</p>	 <p>xx2000002051</p>

Continues on next page

5 Repair

5.3.5 Replacing the axis-4 cabling

Continued

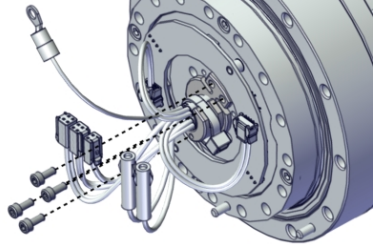
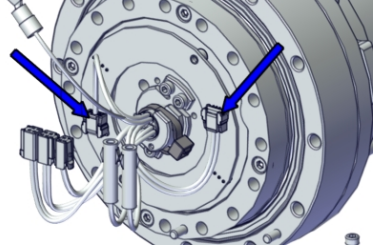
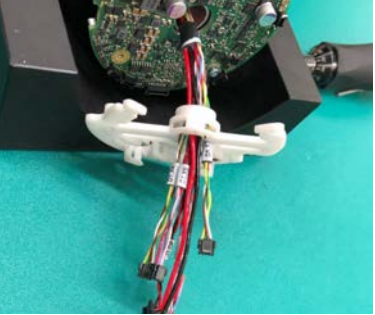
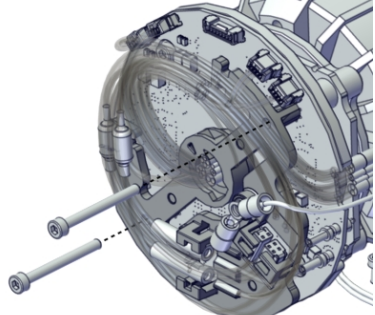
	Action	Note
4	Secure the cable plate to the joint unit with the attachment screws.	<p>Hex socket head cap screw: M2.5x6 12.9 Lafre 2C2B/FC6.9 (4 pcs) Tightening torque: 0.45 Nm.</p>  <p>xx2000002049</p>
5	Connect the two connectors to the torque sensor board. <ul style="list-style-type: none">• TQ.A to CH1/A• TQ.B to CH2/B	 <p>xx2000002053</p>
6	Insert the cabling through the cable support and fit the support to the drive board with the attachment screws.	 <p>xx2000002056</p> <p>Hex socket head cap screw: M3x30 12.9 Lafre 2C2B/FC6.9 (2 pcs) Tightening torque: 0.45 Nm.</p>  <p>xx2000002055</p>

Continues on next page

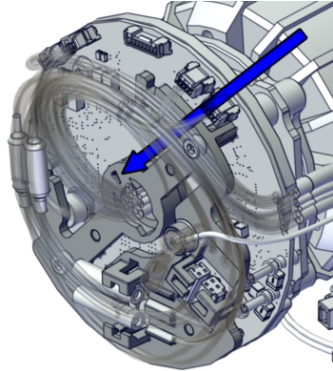
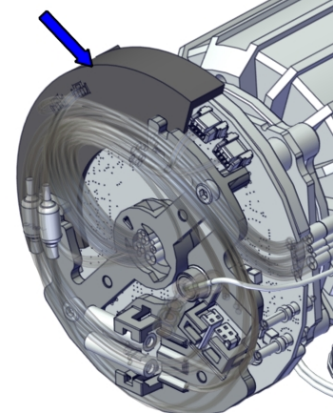
	Action	Note
7	<p>Keep the cabling loose, making sure not to twist or strain it. Use the cable tie to pre-fix the cable by hand.</p>	 <p>xx2100000507</p>
8	<p>Fit the protection plate to the drive board unit.</p>	<p>Protection plate: 3HAC077790-001 (for CRB 15000-5/0.95) / 3HAC087789-001 (for CRB 15000-10/1.52 and CRB 15000-12/1.27)</p>  <p>xx2000002057</p>

Continues on next page

5 Repair

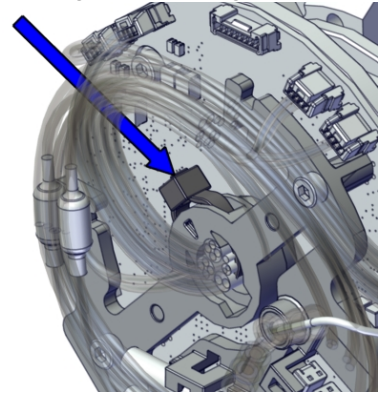
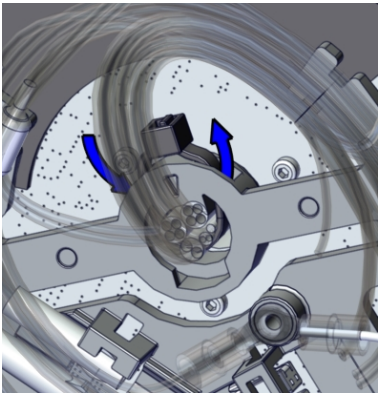
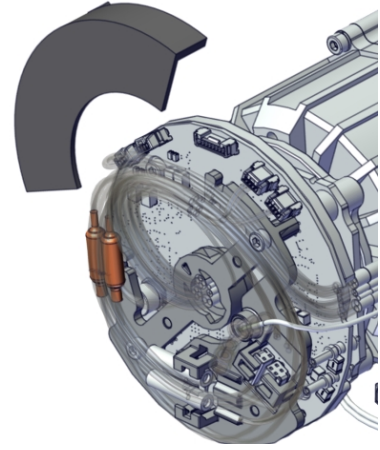

5.3.5 Replacing the axis-4 cabling

Continued

	Action	Note
9	<p>Secure the cables to the cable support with a cable tie, using a cable tie gun.</p> <p>Assembly direction for the cable tie is shown in the figure.</p>	<p>Cable tie: 3HAC075545-001. For securing joint unit cable.</p> <p>Cable tie gun EVO 7i</p> <p>Setting for cable tie gun: 6.75.</p>  <p>xx200002058</p>  <p>xx200002059</p>
10	<p>Remove the protection plate.</p>	 <p>xx210000301</p>

Continues on next page

Preparations before fitting the joint unit

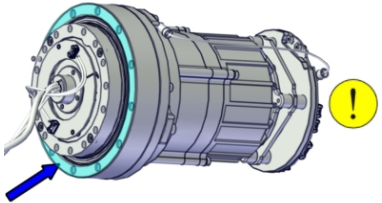
	Action	Note
1	 ELECTROSTATIC DISCHARGE (ESD) The unit is sensitive to ESD. Before handling the unit read the safety information in section <i>The unit is sensitive to ESD on page 53</i> .	
2	Clean the mounting surface of the joint unit and the mating surface on the casting with isopropanol. Joint unit mounting surface is pointed out in the figure.	Cleaning agent: Isopropanol Flange sealant: Loctite 574
3	Apply a thin layer of flange sealant to the mounting surface. Do not contaminate the radial sealing with sealant.  CAUTION The connectors and the joint unit cables are sensitive to mechanical damage. Handle the assembly with care.  ELECTROSTATIC DISCHARGE (ESD) The unit is sensitive to ESD. Before handling the unit read the safety information in section <i>The unit is sensitive to ESD on page 53</i> .	 xx2000001860

Refitting the axis-4 joint unit



	Action	Note
1	 CAUTION Axis-4 joint unit used for CRB 15000-5/0.95 has the same appearance as that used for CRB 15000-10/1.52 and CRB 15000-12/1.27. Do not mix the joint units for different manipulator variants. Always check the mark or label on the joint units before refitting.	

Continues on next page

5 Repair

5.3.5 Replacing the axis-4 cabling

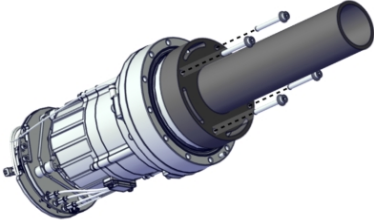
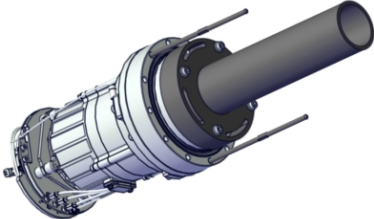
Continued

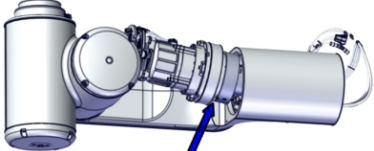
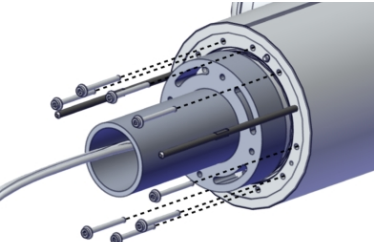
	Action	Note
2	<p>Fit the lifting aid to the joint unit.</p> <p> CAUTION</p> <p>The connectors and the joint unit cables are sensitive to mechanical damage. Handle the assembly with care.</p>	<p>Joint unit: 3HAC079143-001 (for CRB 15000-5/0.95) / 3HAC087546-001 (for CRB 15000-10/1.52 and CRB 15000-12/1.27)</p> <p>Lifting aid: 3HAC077789-001</p> <p>Screws: M3x12 (4 pcs)</p>  <p>xx2000001957</p>
3	<p>Fit two guide pins to the joint unit.</p>	<p>Guide pin, M3x110: 3HAC077787-001</p> <p>Always use guide pins in pairs.</p> <p>For joint units on axes 4, 5 and 6.</p>  <p>xx2000002438</p>
4	<p>Fit the joint unit to the tubular, aligning the pin with the pin hole.</p> <p> CAUTION</p> <p>The connectors and the joint unit cables are sensitive to mechanical damage. Handle the assembly with care.</p>	 <p>xx2000002117</p>
5	<p>Secure the joint unit with new attachment screws.</p>	<p>Flange socket head screw with glue: 3HAB3413-330</p> <p>M3x30 12.9 Lafre 2C2B/FC6.9+PrO-COat111, with NYPLAS glue, 12 pcs</p> <p>Always use new screws when refitting a joint unit. If ordering a new joint unit spare part, new screws are included.</p>  <p>xx2100000326</p>

Continues on next page

5.3.5 Replacing the axis-4 cabling
Continued

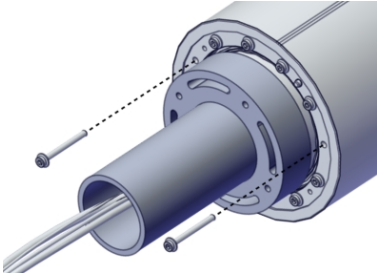
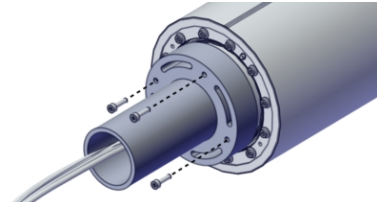
	Action	Note
6	Remove the guide pins and secure the remaining two attachment screws.	 <p>xx2000002091</p>
7	Pre-tighten the screws crosswise.	
8	Torque tighten all screws crosswise.	Tightening torque: 1.4 Nm (for CRB 15000-5/0.95) / 1.9 Nm (for CRB 15000-10/1.52 and CRB 15000-12/1.27)
9	Remove the lifting aid by removing the screws.	 <p>xx2000002090</p>
10	Clean pushed-out flange sealant, if any.	

Connecting the axis-4 joint unit cabling

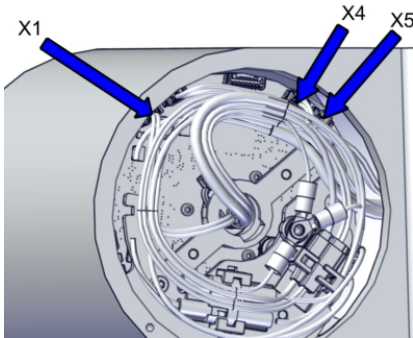
	Action	Note
1	Reconnect the connectors to the drive board. <ul style="list-style-type: none"> • D4/5.X1 to X1 • D4/5.X4 to X4 • D4/5.X5 to X5 	 <p>xx2000002088</p>

Continues on next page

5 Repair

5.3.5 Replacing the axis-4 cabling

Continued

Connecting the tilt cabling

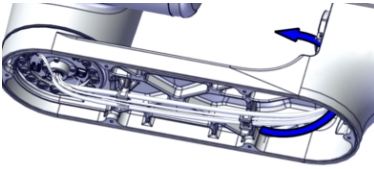
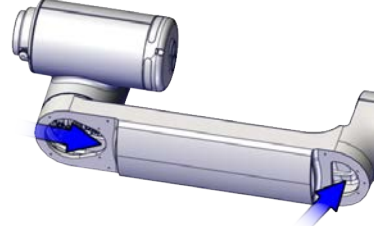
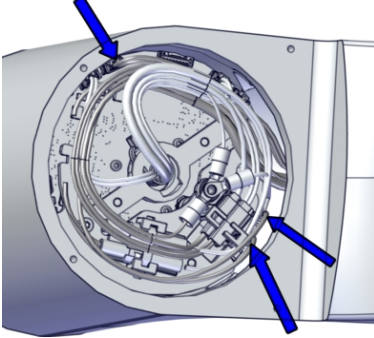
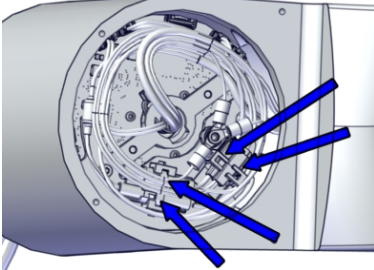
	Action	Note
1	Insert the cabling into the tubular.	<p>Valid for CRB 15000-5/0.95</p>  <p>xx2000002148</p> <p>Valid for CRB 15000-10/1.52 and CRB 15000-12/1.27</p>  <p>xx2300000845</p>
2	<p>Reconnect the connectors to the drive board.</p> <ul style="list-style-type: none"> • D3/4.X2 to X2 • D3/4.DC- to Ground • D3/4.DC+ to +DC 	 <p>xx2000002125</p>
3	<p>Connect the connectors to each other and snap them to the cable holders.</p> <ul style="list-style-type: none"> • J4/5.DC+ to J5/6.DC+ • J4/5.DC- to J5/6.DC- • J4/5.CS to J5/6.CS • J4/5.CP to J5/6.CP 	 <p>xx2000002089</p>

Continues on next page

5.3.5 Replacing the axis-4 cabling
Continued

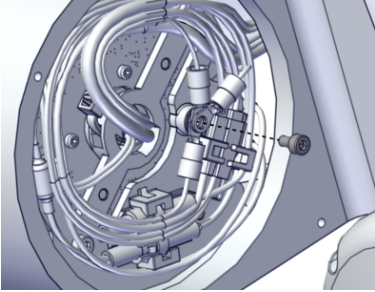
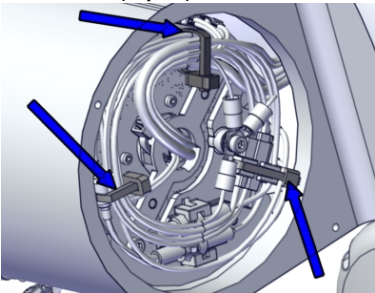
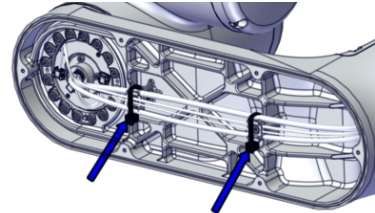
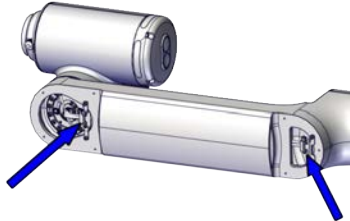
	Action	Note
4	Secure the cables for functional earth and protective earth with a screw.	<p>Hex socket head cap screw: M3x6 (1 pcs). Tightening torque: 0.8 Nm.</p>  <p>xx2000002087</p>
5	Secure the cabling to joint unit with cable ties.	<p>Cable ties (3 pcs)</p>  <p>xx2000002086</p>
6	Secure the cabling to tubular with cable ties.	<p>Cable ties (2 pcs) Valid for CRB 15000-5/0.95</p>  <p>xx2000002124</p> <p>Valid for CRB 15000-10/1.52 and CRB 15000-12/1.27</p>  <p>xx2300000842</p>

Continues on next page

5 Repair

5.3.5 Replacing the axis-4 cabling

Continued

Refitting the tubular cover (-5/0.95)

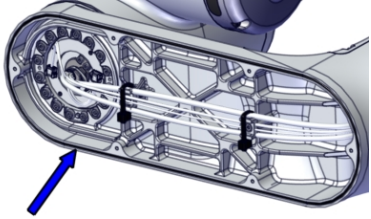
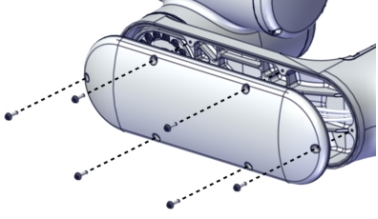
	Action	Note
1	Wipe, lubricate and fit the o-ring to its groove. Replace if damaged.	<p>O-ring: 3HAC061327-043 Grease: 3HAC042536-001 (Shell Gadus S2)</p>  <p>xx2000002149</p>
2	Refit the cover with new attachment screws.	<p>Flange socket head screw with glue: 3HAB3413-312 M3x12 12.9 Lafre 2C2B/FC6.9+PrO-COat111, with NYPLAS glue For tubular cover of CRB 15000-5/0.95. Always use new screws. If ordering a new axis-4 or axis-5 joint unit spare part, new screws for the tubular cover are included. Tightening torque: 1.6 Nm.</p>  <p>xx2000002123</p>

Continues on next page

Refitting the tubular cover (-10/1.52 and -12/1.27)

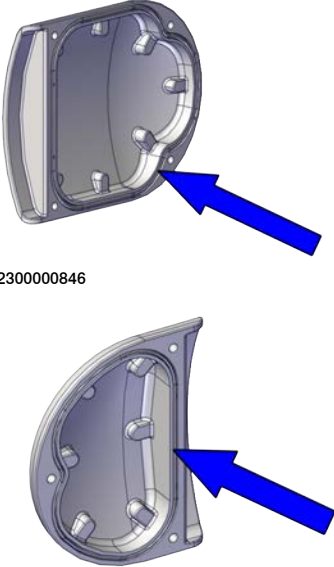
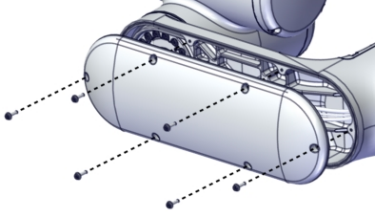
	Action	Note
1	Wipe, lubricate and fit the o-ring to its groove. Replace if damaged.	<p>O-ring: 3HAC061327-076 O-ring: 3HAB3772-166 Grease: 3HAC042536-001 (Shell Gadus S2)</p>  <p>xx2300000846</p> <p>xx2300000847</p>
2	Refit the covers with new attachment screws.	<p>Hex socket head cap screw: 3HAB3409-224 M3x12 12.9 Lafre 2C2B/FC6.9 (3 pcs) Tightening torque: 1.4 Nm.</p>  <p>xx2000002123</p>

Continues on next page

5 Repair

5.3.5 Replacing the axis-4 cabling

Continued

Refitting the axis-4 cover

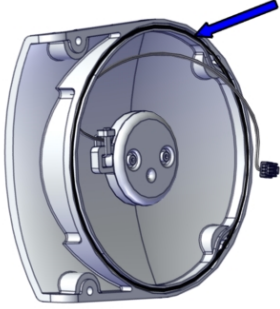
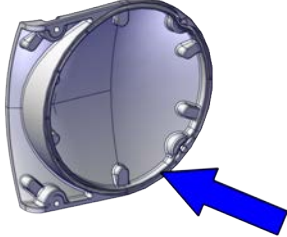
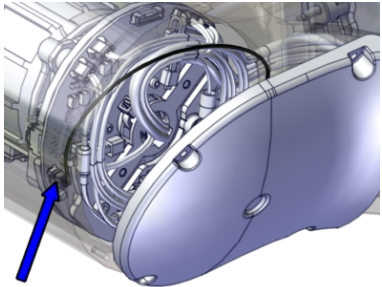
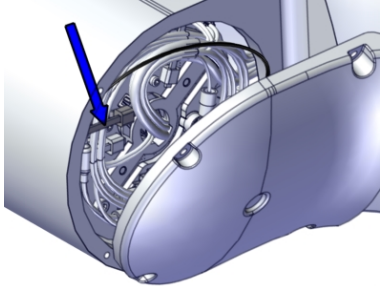
	Action	Note
1	Fit the o-ring to its groove. Replace if damaged.	<p>Valid for CRB 15000-5/0.95 O-ring: 3HAC061327-051</p>  <p>xx200002092</p> <p>Valid for CRB 15000-10/1.52 and CRB 15000-12/1.27 O-ring: 3HAC061327-051</p>  <p>xx2300000848</p>
2	For robots with RobotWare earlier than 7.10 Place the cover at mounting position and reconnect the brake release connector DR.X8 to the drive board.	<p>Tweezers</p>  <p>xx200002085</p>
3	For robots with RobotWare earlier than 7.10 Secure the brake release cable with a cable tie.	<p>Cable ties</p>  <p>xx200002084</p>

Continues on next page

5.3.5 Replacing the axis-4 cabling
Continued

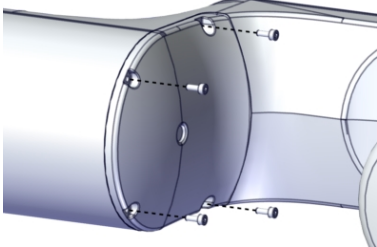
	Action	Note
4	Refit the cover with the four screws.	<p>Hex socket head cap screw: M3x8 12.9 Lafre 2C2B/FC6.9 (4 pcs) Tightening torque: 0.2 Nm (for CRB 15000-5/0.95) / 0.9 Nm (for CRB 15000-10/1.52 and CRB 15000-12/1.27) Tightening torque: 0.9 Nm</p>  <p>xx2000002083</p>

Refitting the tubular

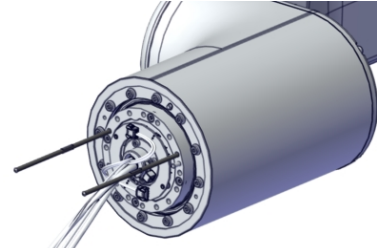
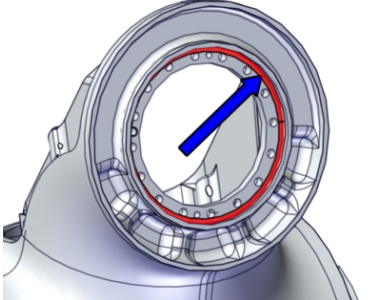
	Action	Note
1	Fit two guide pins to the axis-4 joint.	<p>Guide pin, M3x110: 3HAC077787-001 Always use guide pins in pairs.</p>  <p>xx2000002093</p>
2	Clean the mounting surface with isopropanol. Apply flange sealant to the corner of the housing mounting surface, as pointed out in the figure.	<p>Cleaning agent: Isopropanol Flange sealant: Loctite 574</p>  <p>xx2000002094</p>

Continues on next page

5 Repair

5.3.5 Replacing the axis-4 cabling

Continued

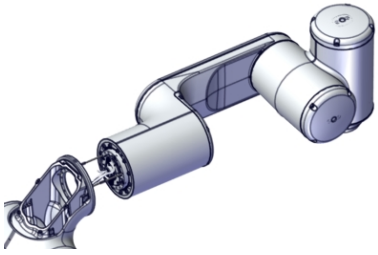
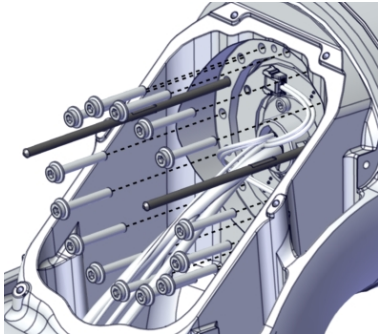
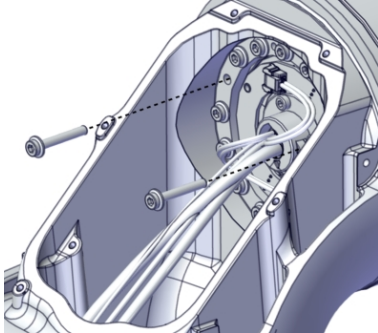
	Action	Note
3	Lift the tubular into mounting position while inserting the cabling into the housing.	 xx2000002082
4	Slide the tubular into place on the guide pins.	
5	Secure the tubular to the housing with all attachment screws but two. Pre-tighten the screws crosswise firstly.	Flange socket head screw: M3x20 12.9 Lafre 2C2B/FC6.9+PrO- COat111  xx2000002081
6	Remove the guide pins and fasten the remaining two screws.	Flange socket head screw: M3x20 12.9 Lafre 2C2B/FC6.9+PrO- COat111  xx2000002079
7	Torque tighten all screws crosswise.	Tightening torque: 1.8 Nm.

Continues on next page

5.3.5 Replacing the axis-4 cabling
Continued

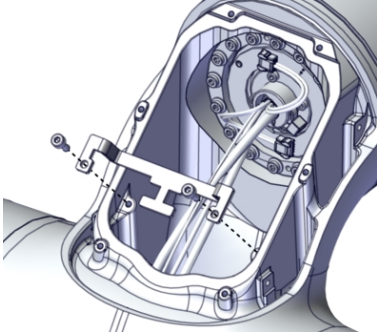
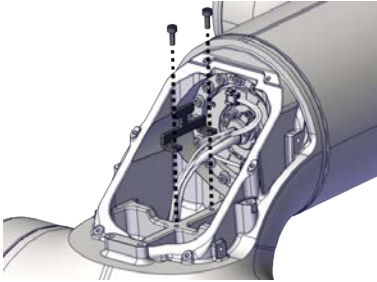
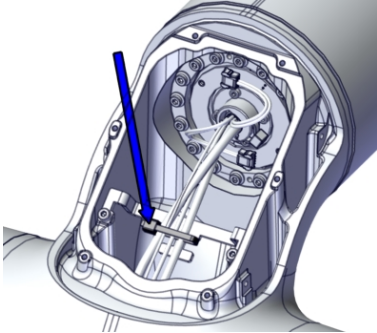
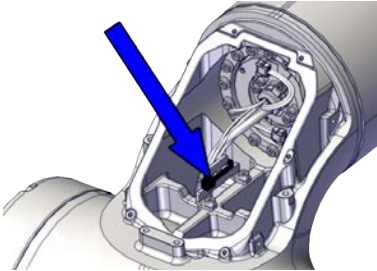
	Action	Note
8	Refit the cable bracket with the two screws.	<p>Hex socket head cap screw: M3x8 12.9 Lafre 2C2B/FC6.9 (4 pcs). Tightening torque: 0.8 Nm Valid for CRB 15000-5/0.95</p>  <p>xx2000002078</p> <p>Valid for CRB 15000-10/1.52 and CRB 15000-12/1.27</p>  <p>xx2300000840</p>
9	Secure the cabling with a cable tie.	<p>Cable ties (1 pcs) Valid for CRB 15000-5/0.95</p>  <p>xx2000002077</p> <p>Valid for CRB 15000-10/1.52 and CRB 15000-12/1.27</p>  <p>xx2300000839</p>

Continues on next page

5 Repair

5.3.5 Replacing the axis-4 cabling

Continued

Closing the housing top cover

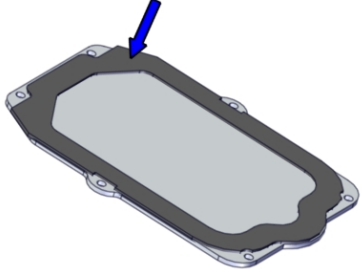
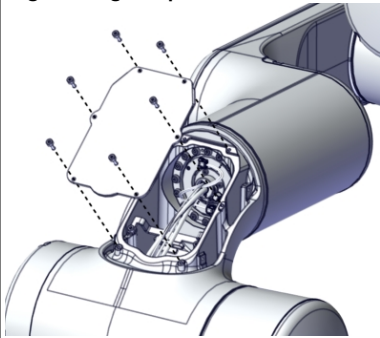
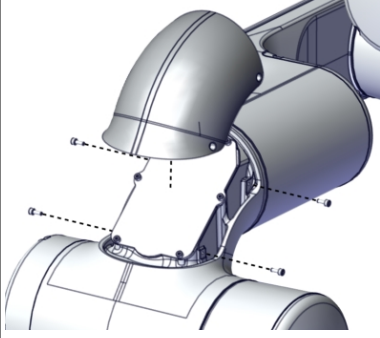
	Action	Note
1	Check the inner plate gasket. Replace if damaged.	Gasket: 3HAC075056-001  xx2000002095
2	Refit the inner plate with the screws.	Hex socket head cap screw: M3x8 12.9 Lafre 2C2B/FC6.9 (4 pcs). Tightening torque: 1.4 Nm  xx2000002076
3	Refit the cover with the four screws.	Hex socket head cap screw: M3x8 12.9 Lafre 2C2B/FC6.9 (4 pcs). Tightening torque: 0.45 Nm  xx2000002075

Continues on next page

Connecting the tubular cabling

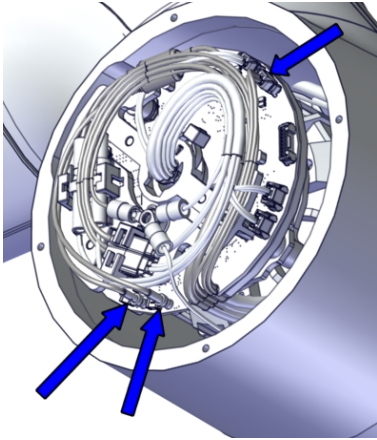
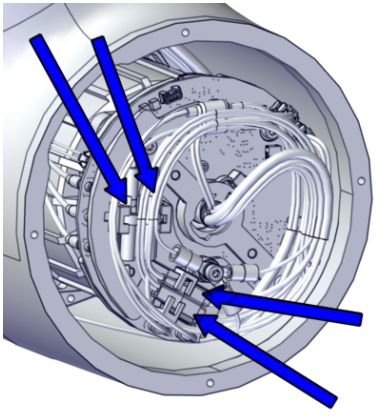
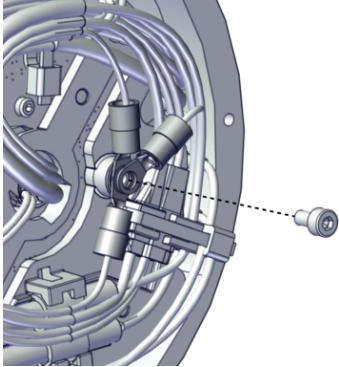
	Action	Note
1	Reconnect the connectors to the drive board. <ul style="list-style-type: none"> • D3/4.DC+ to DC+ • D3/4.DC- to Ground • D3/4.X2 to X2 	 <p>xx2000002120</p>
2	Connect the connectors to each other and snap them to the cable holders. <ul style="list-style-type: none"> • J3.DC+ to J3.DC+ • J3.DC- to J3.DC- • J3.CS to J3.CS • J3.CP to J3.CP 	 <p>xx2000002067</p>
3	Secure the cables for functional earth and protective earth with a screw.	Hex socket head cap screw: M3x6 (1 pcs). Tightening torque: 0.8 Nm.  <p>xx2000001945</p>

Continues on next page

5 Repair

5.3.5 Replacing the axis-4 cabling

Continued

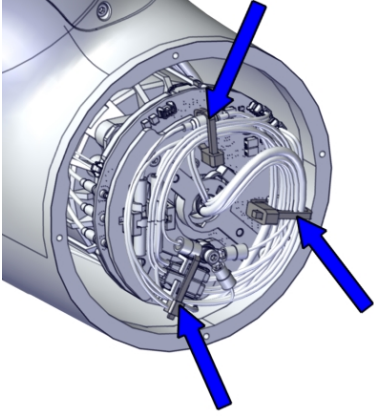
	Action	Note
4	Secure the cabling with cable ties.	Cable ties (3 pcs)  <small>xx2000002066</small>

Refitting the housing cover (-5/0.95)

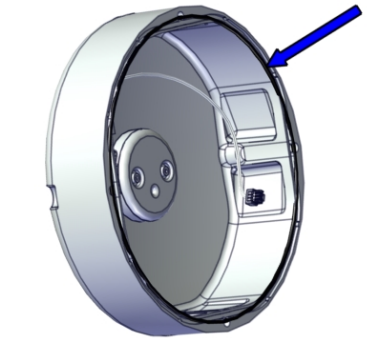
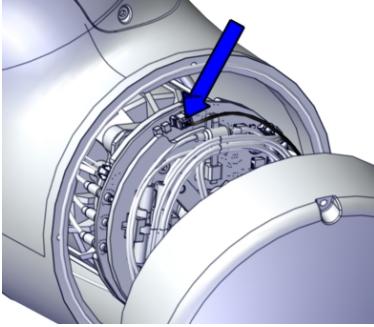
	Action	Note
1	Fit the o-ring to its groove. Replace if damaged.	O-ring: 3HAC061327-047  <small>xx2000001962</small>
2	For robots with RobotWare earlier than 7.10 Place the cover at mounting position and reconnect the brake release connector DR.X8 to the drive board. Orient the cover for proper arrangement of the brake release cable.	 <small>xx2000002023</small>

Continues on next page

5.3.5 Replacing the axis-4 cabling
Continued

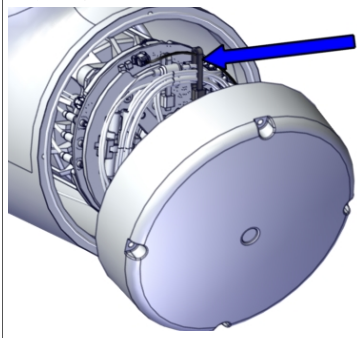
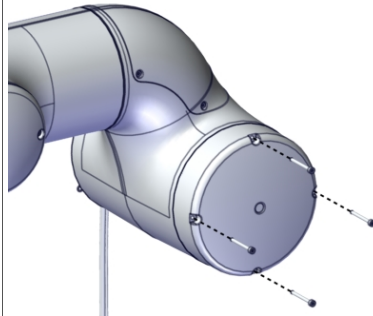
	Action	Note
3	<p>For robots with RobotWare earlier than 7.10 Secure the brake release cable with a cable tie.</p>	<p>Cable ties</p>  <p>xx2000002022</p>
4	<p>Refit the cover with the four screws.</p>	<p>Hex socket head cap screw: M3x30 12.9 Lafre 2C2B/FC6.9 (4 pcs) Tightening torque: 0.45 Nm</p>  <p>xx2000002021</p>

Refitting the housing cover and insert (-10/1.52 and -12/1.27)

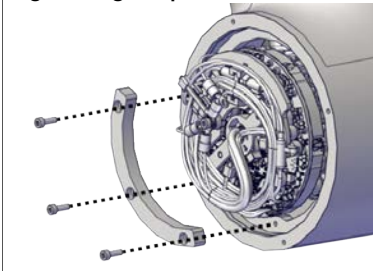
	Action	Note
1	<p>Refit the insert.</p>	<p>Insert: 3HAC084002-001 Hex socket head cap screw: M3x10 12.9 Lafre 2C2B/FC6.9 (3 pcs) Tightening torque: 1.4 Nm</p>  <p>xx2300000834</p>

Continues on next page

5 Repair

5.3.5 Replacing the axis-4 cabling

Continued

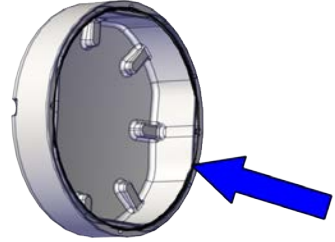
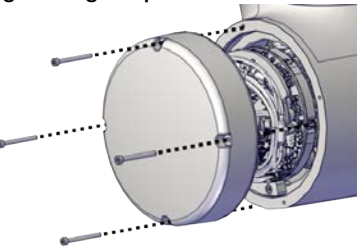
	Action	Note
2	Fit the o-ring to its groove. Replace if damaged.	O-ring: 3HAC061327-047  xx2300000835
3	Refit the cover with the four screws.	Hex socket head cap screw: M3x30 12.9 Lafre 2C2B/FC6.9 (4 pcs) Tightening torque: 1.4 Nm  xx2300000833

Concluding procedure

	Action	Note
1	<p>Calibrate the joint unit torque sensor.</p> <ol style="list-style-type: none"> 1 On the FlexPendant, go to the Code app and call the calibration procedure using PP to Routine, not by using Call Routine. 2 Select the Joint Unit Replacement feature and then select the axis to calibrate. 3 The controller is now restarted. Once the home screen of the FlexPendant is shown, press the Play button to continue the calibration routine. 4 The robot moves to a position or positions where measurements are performed. 5 The results of the measurements are presented together with the current values in the controller. Choose whether to save the calibration data or not. 6 If new calibration data is saved you will be asked to do a test with the lead-through functionality active to verify that the sensors work correctly. 7 Finally the robot is moved back to the original position. 8 Test the brake release (movement without drive power) functionality, see Testing the brake release functionality on page 196. 	See Calibration on page 1063

Continues on next page

	Action	Note
2	 DANGER Make sure all safety requirements are met when performing the first test run. See Test run after installation, maintenance, or repair on page 90 .	

5 Repair

5.3.6 Replacing the axis-5 cabling

5.3.6 Replacing the axis-5 cabling

Location of the cable harness

The cable harness is located as shown in the figure.

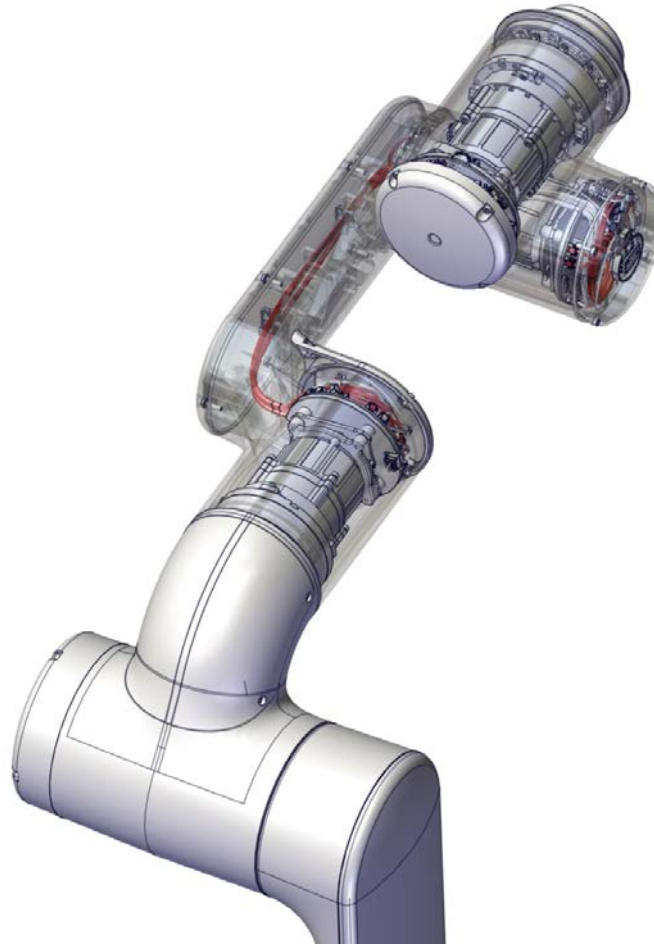

xx210000061

Summary of the replacement procedure

This is a brief summary of the replacement procedure, containing the major actions to be performed.

- 1 Remove the tubular cover.
- 2 Separate the cabling between the tubular and the tilt (at the axis-4 joint unit).
- 3 Remove the tilt and place on a workbench.
- 4 Remove the axis-6 joint unit.
- 5 Remove the axis-5 cover.
- 6 Remove the axis-5 joint unit.
- 7 Replace the cabling.

Continues on next page

Required spare parts



Note

The spare part numbers that are listed in the table can be out of date. See the latest spare parts of the CRB 15000 via myABB Business Portal, www.abb.com/myABB.

Spare part	Article number	Note
Cable harness, joint 5	3HAC073206-001	Used for CRB 15000-5/0.95. Also order new Cable tie: 3HAC075545-001.
Cable harness, joint 5 (CRB 15000-10/1.52)	3HAC083669-001	Used for CRB 15000-10/1.52. Also order new Cable tie: 3HAC075545-001.
Cable harness, joint 5 (CRB 15000-12/1.27)	3HAC083668-001	Used for CRB 15000-12/1.27. Also order new Cable tie: 3HAC075545-001.
Cable tie	3HAC075545-001	For securing joint unit cable.

Required tools and equipment

Equipment	Article number	Note
Lifting aid	3HAC077789-001	For joint units on axes 4, 5 and 6. Attachment screws M3x12 (4 pcs) are enclosed.
Guide pin, M3x110	3HAC077787-001	Always use guide pins in pairs. For joint units on axes 4, 5 and 6.
Tweezers	-	Used to handle drive board connectors.
Protection plate	3HAC077790-001	For protection of drive board during cabling installation on joint units of CRB 15000-5/0.95.
Cable tie gun EVO 7i	-	HellermannTyton 110-77001 or similar
Standard toolkit	-	Content is defined in section Standard toolkit on page 1099 .

Required consumables

Consumable	Article number	Note
Cable ties	-	
O-ring	3HAC061327-051	Axis-5 cover, used for CRB 15000-5/0.95. Replace if damaged.
O-ring	3HAC061327-051	Axis-5 cover, used for CRB 15000-10/1.52 and CRB 15000-12/1.27. Replace if damaged.

Continues on next page

5 Repair

5.3.6 Replacing the axis-5 cabling

Continued

Consumable	Article number	Note
O-ring	3HAC061327-051	Axis-4 cover, used for CRB 15000-5/0.95. Replace if damaged.
O-ring	3HAC061327-051	Axis-4 cover, used for CRB 15000-10/1.52 and CRB 15000-12/1.27. Replace if damaged.
O-ring	3HAC061327-043	Tubular cover, used for CRB 15000-5/0.95. Replace if damaged.
O-ring	3HAB3772-166	Tubular cover, upper, used for CRB 15000-10/1.52 and CRB 15000-12/1.27. Replace if damaged.
O-ring	3HAC061327-076	Tubular cover, lower, used for CRB 15000-10/1.52 and CRB 15000-12/1.27. Replace if damaged.
O-ring	3HAC061327-051	Arm-side interface Replace if damaged.
Grease	3HAC042536-001	Shell Gadus S2
Flange socket head screw with glue	3HAB3413-312	M3x12 12.9 Lafre 2C2B/FC6.9+PrO-COat111, with NYPLAS glue For tubular cover of CRB 15000-5/0.95. Always use new screws. If ordering a new axis-4 or axis-5 joint unit spare part, new screws for the tubular cover are included.
Cleaning agent	-	Isopropanol
Flange sealant	-	Loctite 574

Removing the joint cabling

Use these procedures to remove the joint-5 cabling.

Preparations before removing the cabling



	Action	Note
1	Jog the robot to the specified position: <ul style="list-style-type: none"> Axis 1: No significance. Axis 2: No significance. Axis 3: No significance. Axis 4: No significance. Axis 5: 0° (home position) Axis 6: No significance. 	
2	 CAUTION Turn off all supplies for electrical power to the robot, before starting the repair work.	

Continues on next page

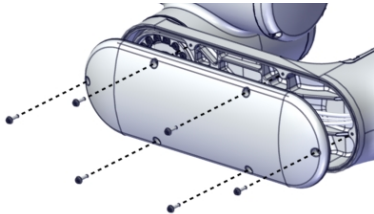
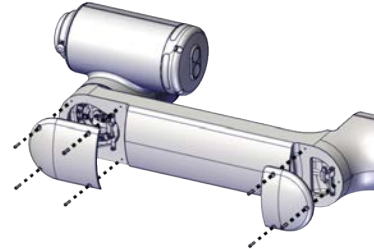
Removing the tubular cover

	Action	Note
1	<p>Valid for CRB 15000-5/0.95</p> <p>Remove the cover by removing the six screws. Dispose the screws. New screws must be used when refitting the cover. New screws are included in the spare part delivery of the joint unit.</p>	 <p>xx2000002123</p>
2	<p>Valid for CRB 15000-10/1.52 and CRB 15000-12/1.27</p> <p>Remove the covers by removing the screws.</p>	 <p>xx2300000841</p>

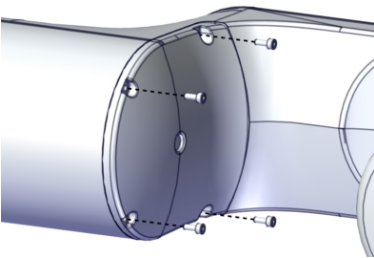
Removing the axis-4 cover

	Action	Note
1	<p>Remove the cover screws.</p>	 <p>xx2000002083</p>
2	<p> CAUTION</p> <p>Valid for CRB 15000-5/0.95</p> <p>There is cabling connected between the cover and the joint unit drive board. Open the cover with care to avoid damage to the cabling or the connector(s). Do not leave the cover in location without being secured with the attachment screws.</p>	

Continues on next page

5 Repair

5.3.6 Replacing the axis-5 cabling

Continued

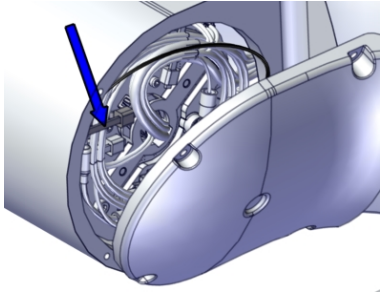
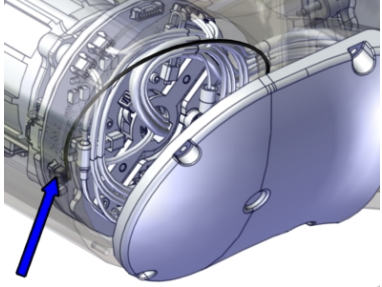
	Action	Note
3	For robots with RobotWare earlier than 7.10 Open the cover and cut the cable tie that holds the brake release cable.	 xx2000002084
4	For robots with RobotWare earlier than 7.10 Disconnect the brake release connector DR.X8 from the drive board. Remove the cover.	Tweezers  xx2000002085

Separating the cabling between the tubular and the tilt

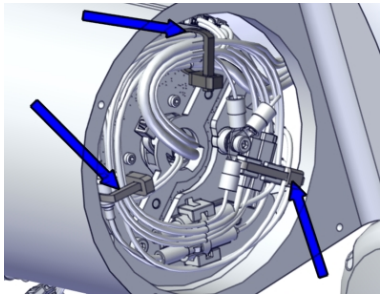
	Action	Note
1	Cut the cable ties on joint unit.	 xx2000002086

Continues on next page

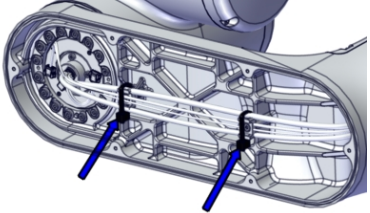
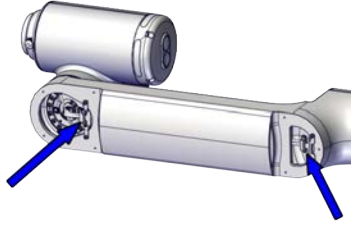
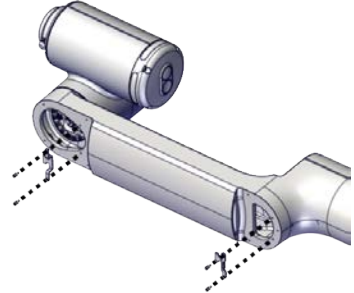
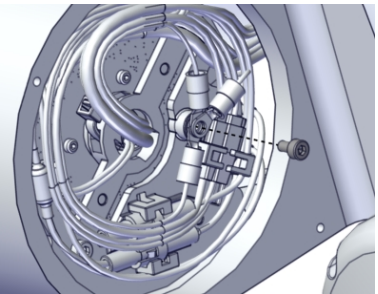
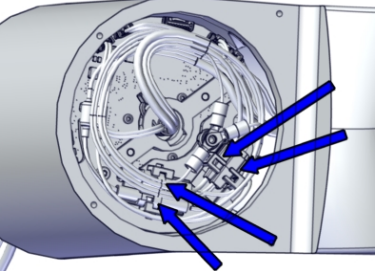
	Action	Note
2	Cut the cable ties on tubular, if needed.	<p>Valid for CRB 15000-5/0.95</p>  <p>xx2000002124</p> <p>Valid for CRB 15000-10/1.52 and CRB 15000-12/1.27</p>  <p>xx2300000842</p>
3	<p>Valid for CRB 15000-10/1.52 and CRB 15000-12/1.27</p> <p>Remove the cable brackets.</p>	 <p>xx2300000843</p>
4	Remove the functional and protective earth cables by removing the screw.	 <p>xx2000002087</p>
5	<p>Snap loose and disconnect the connectors:</p> <ul style="list-style-type: none"> • J4/5.DC+ • J4/5.DC- • J4/5.CS • J4/5.CP 	 <p>xx2000002089</p>

Continues on next page

5 Repair

5.3.6 Replacing the axis-5 cabling

Continued

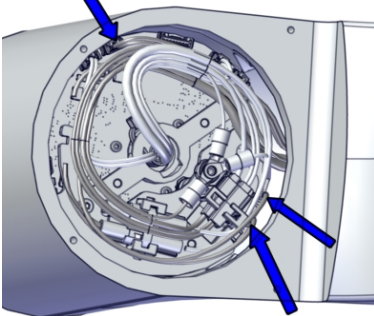
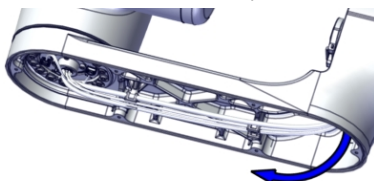
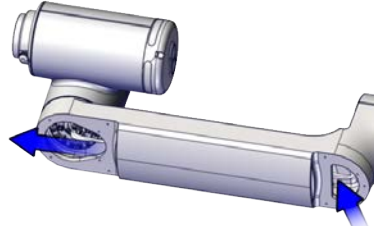
	Action	Note
6	<p>Disconnect the connectors that belongs to the axis-5 cabling, from the axis-4 drive board:</p> <ul style="list-style-type: none">• D3/4.X2• D3/4.DC-• D3/4.DC+ <p>Use tweezers, if needed.</p>	<p>Tweezers</p>  <p>xx2000002125</p>
7	<p>Pull out the cabling carefully from the tubular.</p>	<p>Valid for CRB 15000-5/0.95</p>  <p>xx2000002126</p> <p>Valid for CRB 15000-10/1.52 and CRB 15000-12/1.27</p>  <p>xx2300000844</p>

Continues on next page

Removing the tilt

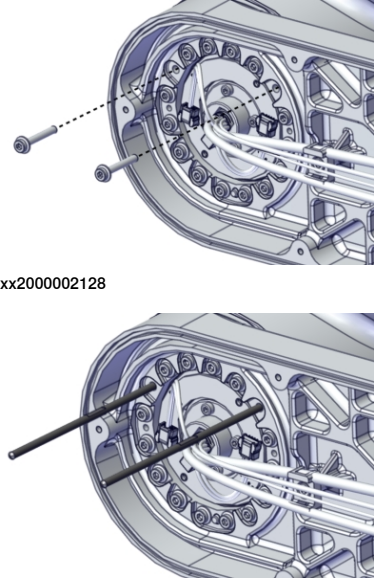
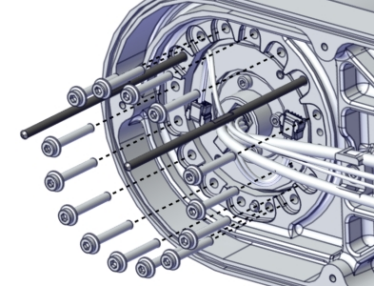
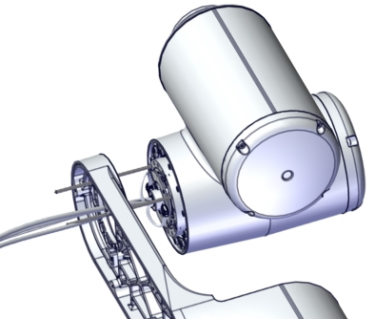
	Action	Note
1	Remove two attachment screws and fit two guide pins to the axis-5 joint unit.	<p>Guide pin, M3x110: 3HAC077787-001</p> <p>Always use guide pins in pairs.</p>  <p>xx2000002128</p> <p>xx2000002129</p>
2	Remove the remaining attachment screws.	 <p>xx2000002130</p>
3	Press the tilt out of position using two of the previous attachment screws as removal tools.	
4	Remove the tilt from the tubular. Assist the cabling to be removed while lifting away the complete tilt. Place the tilt on a workbench.	 <p>xx2000002131</p>



Continues on next page

5 Repair

5.3.6 Replacing the axis-5 cabling

Continued

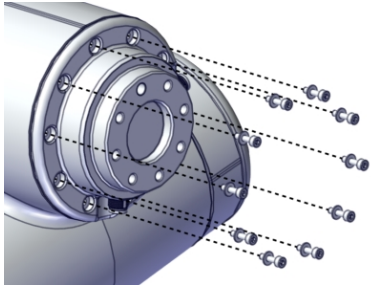
Removing the tool flange

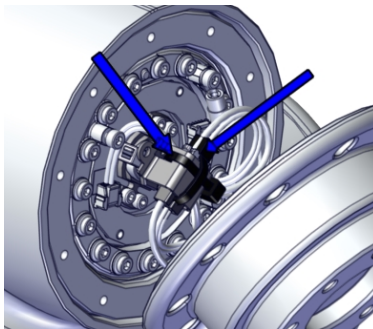
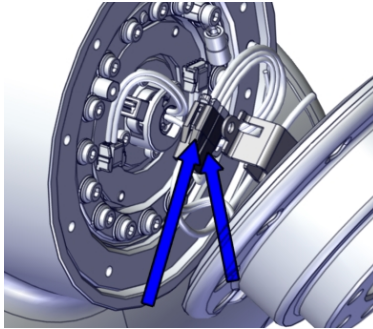
	Action	Note
1	Remove the tool flange screws and washers.	 xx2000002155
2	 CAUTION Valid for CRB 15000-5/0.95 There is cabling connected between the cover and the joint unit drive board. Open the cover with care to avoid damage to the cabling or the connector(s). Do not leave the cover in location without being secured with the attachment screws.	
3	Cut the cable ties.	 xx2000002157
4	Disconnect the CP/CS connectors from the drive board and remove the tool flange.	 xx2000002158

Continues on next page

Disconnecting the tool flange functional earth cable

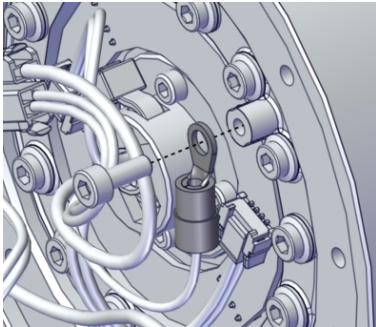
	Action	Note
1	Remove the functional earth cable by removing the screw.	 <p>xx2000002159</p>

Removing the tool flange adapter

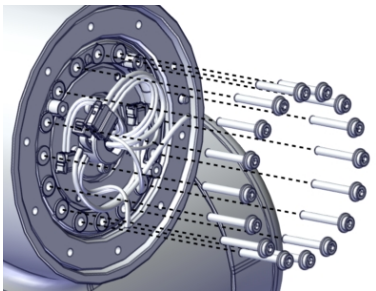
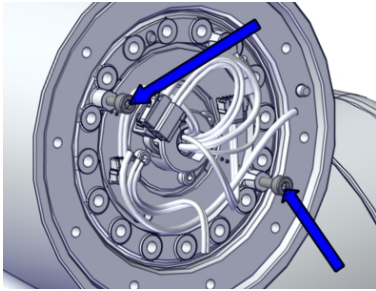
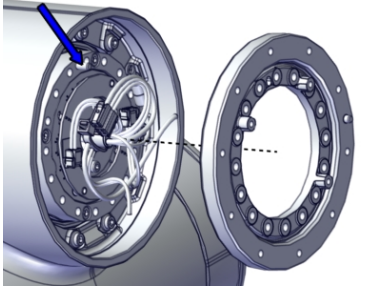
	Action	Note
1	Remove the tool flange adapter screws.	 <p>xx2000002165</p>
2	Press the adapter out of position by using two of the attachment screws as removal tools.	 <p>xx2000002166</p>
3	Remove the tool flange adapter.	 <p>xx2000002167</p>



Continues on next page

5 Repair

5.3.6 Replacing the axis-5 cabling

Continued

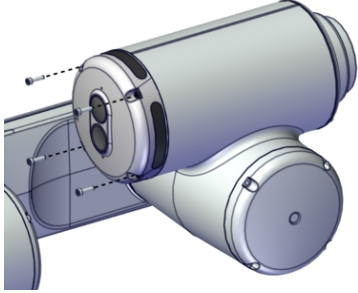
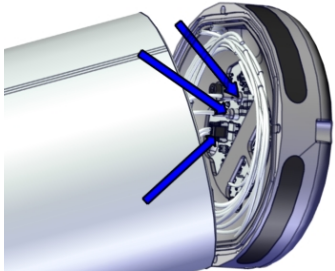

Removing the arm-side interface

	Action	Note
1	 CAUTION Make sure that all supplies for electrical power are turned off.	
2	 CAUTION There is cabling connected between the arm-side interface and the joint unit drive board. Open the arm-side interface with care to avoid damage to the cabling or the connector(s). Do not leave the arm-side interface in location without being secured with the attachment screws.	
3	Remove the attachment screws.	 xx2000002550
4	Loosen the arm-side interface carefully and disconnect the connectors from it. <ul style="list-style-type: none"> • ASI.DC+ • ASI.DC- • ASI.X1 	 xx2100000335

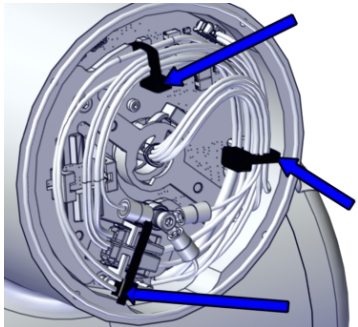
Disconnecting the axis-6 joint unit cabling

	Action	Note
1	Cut the cable ties.	 xx2000002161

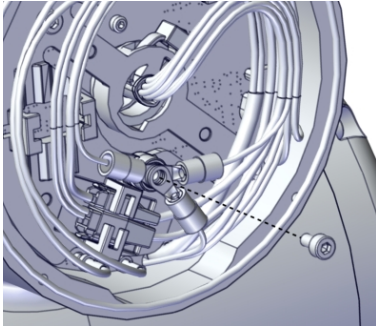
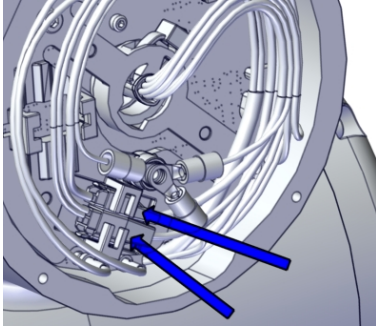
Continues on next page

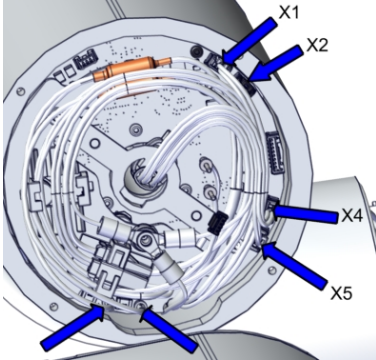
	Action	Note
2	Remove the functional and protective earth cables by removing the screw.	 <p>xx2000002162</p>
3	Snap loose and disconnect the connectors: <ul style="list-style-type: none"> • J7.CS • J7.CP 	 <p>xx2000002163</p>
4	Disconnect the connectors from the drive board. <ul style="list-style-type: none"> • D6.X1 • D6.DC+ • D6.DC- • D6.X4 • D6.X2 • D6.X5 <p> CAUTION</p> <p>Use tweezers to unlock connectors and pull them off.</p>	<p>Tweezers</p>  <p>xx2000002164</p>

Continues on next page

5 Repair



5.3.6 Replacing the axis-5 cabling

Continued

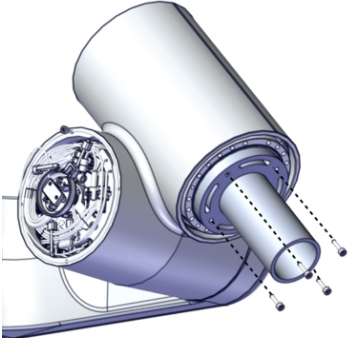
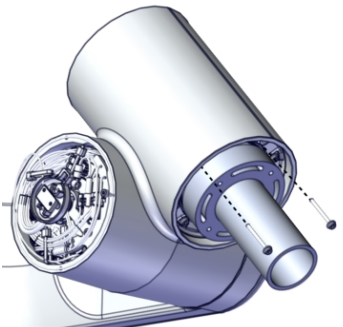
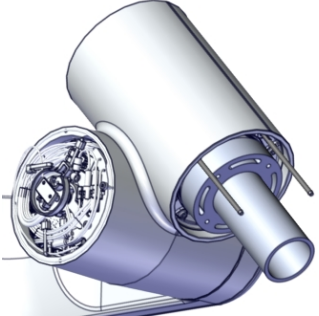
Removing the axis-6 joint unit

	Action	Note
1	<p>Fit the lifting aid to the joint unit, on the torque sensor side.</p> <p> CAUTION</p> <p>The connectors and the joint unit cables are sensitive to mechanical damage. Handle the assembly with care.</p>	<p>Lifting aid: 3HAC077789-001 Screws: M3x12 (4 pcs)</p>  <p>xx2000002168</p> <p>Position shown in the figure shows axis 5 jogged to +20°, which is a more convenient position when replacing only the axis-6 joint unit.</p>
2	<p>Remove two attachment screws. Dispose the screws. New screws are included in the spare part delivery of the joint unit.</p>	 <p>xx2000002170</p> <p>Position shown in the figure shows axis 5 jogged to +20°, which is a more convenient position when replacing only the axis-6 joint unit.</p>
3	<p>Fit two guide pins to the axis-6 joint unit.</p>	<p>Guide pin, M3x110: 3HAC077787-001 Always use guide pins in pairs. For joint units on axes 4, 5 and 6.</p>  <p>xx2100000328</p>

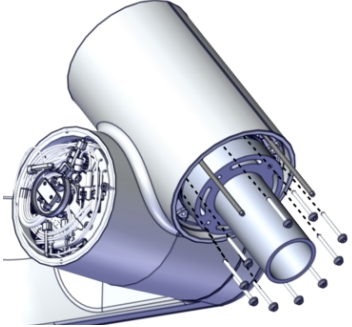
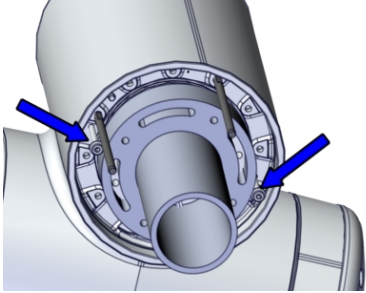
Continues on next page

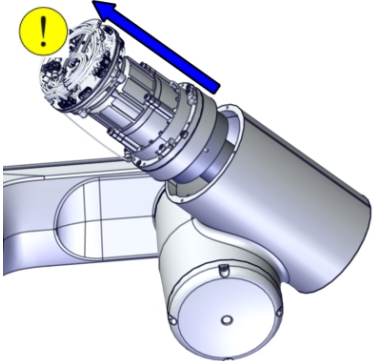
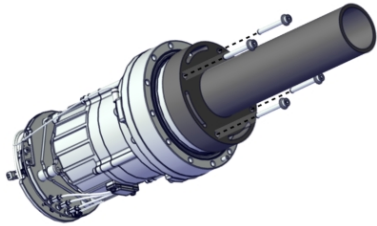
	Action	Note
4	<p>Remove the remaining attachment screws. Use two screws as press out screws in the upcoming step, then dispose all screws. New screws are included in the spare part delivery of the joint unit.</p>	 <p>xx2100000329</p>
5	<p>Press the joint unit out of position using two of the previous attachment screws as removal tools.</p>	 <p>xx2100000330</p>
6	<p>Remove the joint unit from the tubular.</p> <p> CAUTION</p> <p>The connectors and the joint unit cables are sensitive to mechanical damage. Handle the assembly with care.</p>	 <p>xx2000002169</p> <p>Position shown in the figure shows axis 5 jogged to +20°, which is a more convenient position when replacing only the axis-6 joint unit.</p>
7	<p>Remove the lifting aid and guide pins.</p>	 <p>xx2000001957</p>



Continues on next page

5 Repair

5.3.6 Replacing the axis-5 cabling

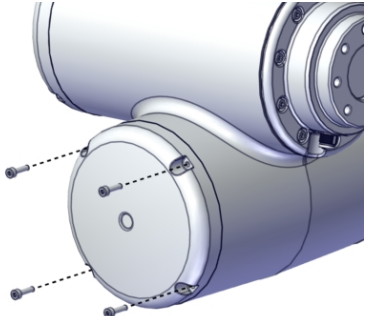

Continued

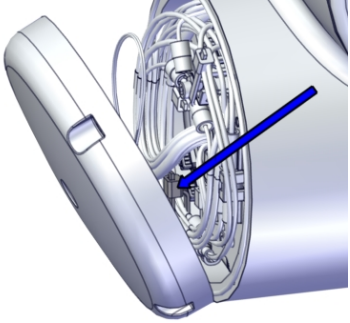
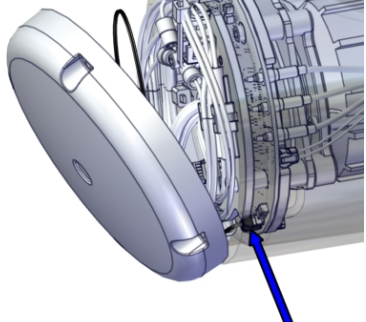
Removing the axis-5 cover

	Action	Note
1	Remove the cover by removing the four screws.	 <p>xx2000002132</p>
2	<p> CAUTION</p> <p>Valid for CRB 15000-5/0.95</p> <p>There is cabling connected between the cover and the joint unit drive board.</p> <p>Open the cover with care to avoid damage to the cabling or the connector(s).</p> <p>Do not leave the cover in location without being secured with the attachment screws.</p>	
3	<p>For robots with RobotWare earlier than 7.10</p> <p>Open the cover and cut the cable tie that holds the brake release cable.</p>	 <p>xx2000002133</p>
4	<p>For robots with RobotWare earlier than 7.10</p> <p>Disconnect the brake release connector DR.X8 from the drive board.</p> <p>Remove the cover.</p>	 <p>xx2000002134</p>

Continues on next page

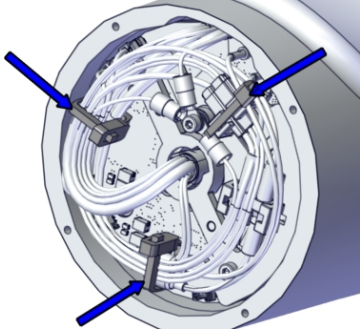
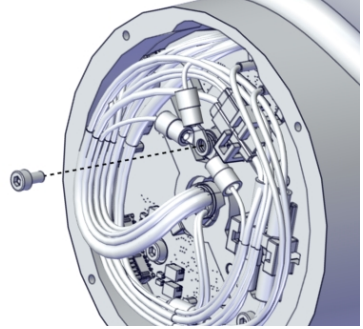
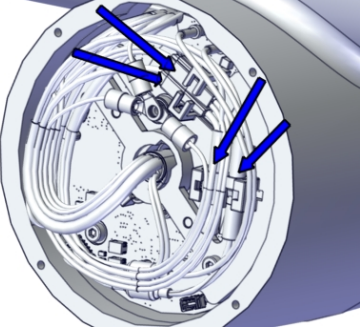
Disconnecting the axis-5 joint unit cabling

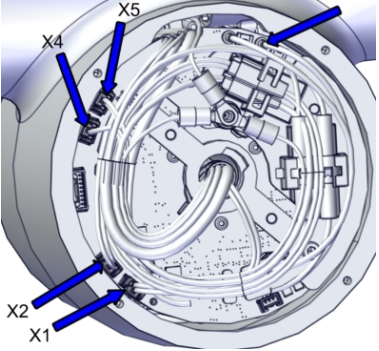
	Action	Note
1	Cut the cable ties.	 <p>xx2000002135</p>
2	Remove the functional and protective earth cables by removing the screw.	 <p>xx2000002136</p>
3	Snap loose and disconnect the connectors: <ul style="list-style-type: none"> • J5/6.DC+ • J5/6.DC- • J5/6.CS • J5/6.CP 	 <p>xx2000002137</p>
4	Disconnect the connectors from the drive board. <ul style="list-style-type: none"> • D4/5.X1 • D5.DC+ • D5.DC- • D4/5.X4 • D5.X2 • D4/5.X5 <p> CAUTION</p> <p>Use tweezers to unlock connectors and pull them off.</p>	<p>Tweezers</p>  <p>xx2000002138</p>

Continues on next page

5 Repair



5.3.6 Replacing the axis-5 cabling

Continued

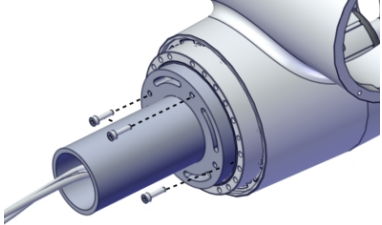
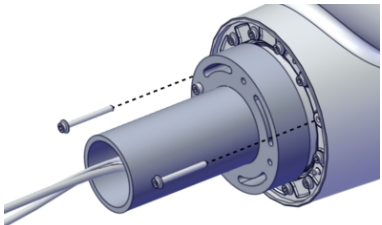
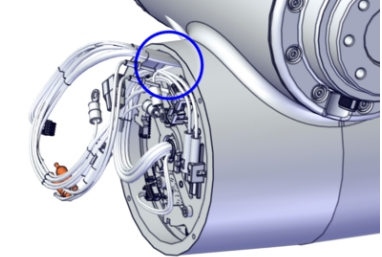
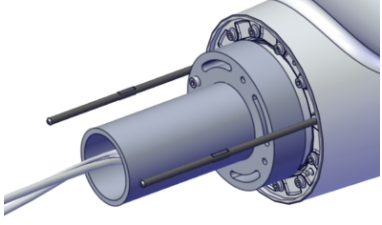
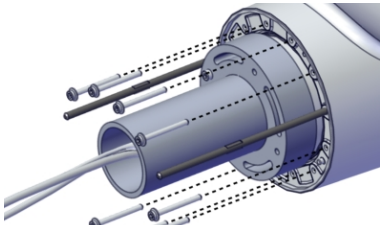

Removing the axis-5 joint unit

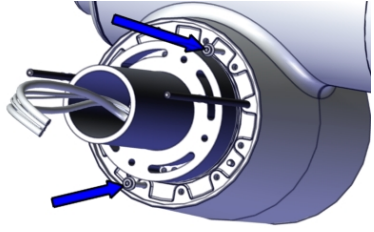
	Action	Note
1	<p>Fit the lifting aid to the joint unit, on the torque sensor side.</p> <p> CAUTION</p> <p>The connectors and the joint unit cables are sensitive to mechanical damage. Handle the assembly with care.</p>	<p>Lifting aid: 3HAC077789-001 Screws: M3x12 (4 pcs)</p>  <p>xx2000002139</p>
2	<p>Remove two attachment screws. Dispose the screws. New screws are included in the spare part delivery of the joint unit.</p>	 <p>xx2000002140</p>
3	<p>Put the cabling at the slot in order not to squeeze it during removal of joint unit.</p>	 <p>xx2100000284</p>
4	<p>Fit two guide pins to the axis-5 joint unit.</p>	<p>Guide pin, M3x110: 3HAC077787-001 Always use guide pins in pairs. For joint units on axes 4, 5 and 6.</p>  <p>xx2100000332</p>
5	<p>Remove the remaining attachment screws. Use two screws as press out screws in the upcoming step, then dispose all screws. New screws are included in the spare part delivery of the joint unit.</p>	 <p>xx2100000333</p>

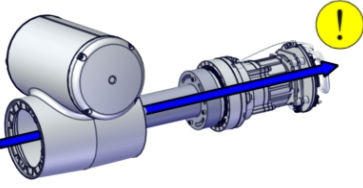
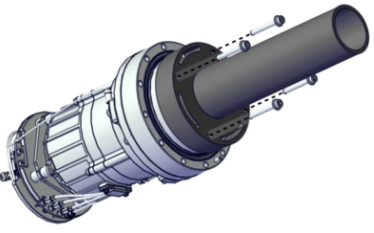
Continues on next page

	Action	Note
6	Press the joint unit out of position using two of the previous attachment screws as removal tools.	 <p>xx2100000334</p>
7	<p>Remove the joint unit from the tubular.</p> <p> CAUTION</p> <p>The connectors and the joint unit cables are sensitive to mechanical damage. Handle the assembly with care.</p>	 <p>xx2000002141</p>
8	Remove the lifting aid and guide pins.	 <p>xx2000001957</p>

Removing the joint cable

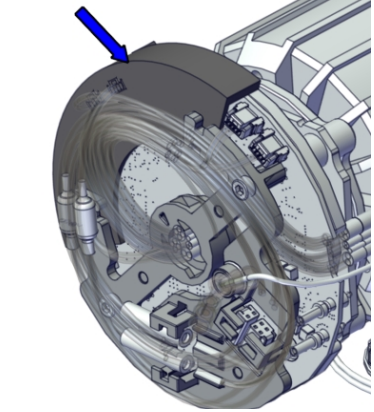
	Action	Note
1	<p> ELECTROSTATIC DISCHARGE (ESD)</p> <p>The unit is sensitive to ESD. Before handling the unit read the safety information in section The unit is sensitive to ESD on page 53.</p>	
2	<p>Fit the protection plate to the drive board unit.</p> <p> Tip</p> <p>Using the protection plate is important for protecting the drive board unit. If complete joint unit is to be replaced, the protection plate is not needed.</p>	<p>Protection plate: 3HAC077790-001 (for CRB 15000-5/0.95) / 3HAC087789-001 (for CRB 15000-10/1.52 and CRB 15000-12/1.27)</p>  <p>xx2000002057</p>

Continues on next page



5 Repair

5.3.6 Replacing the axis-5 cabling

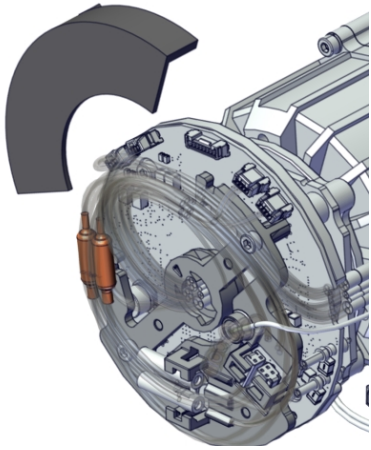
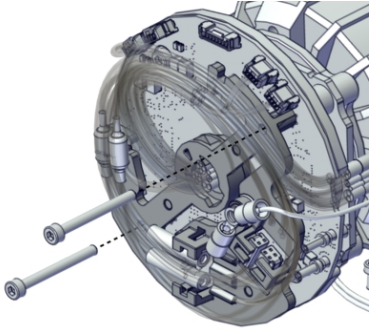
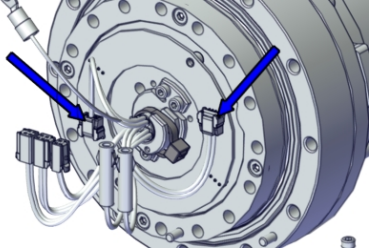
Continued

	Action	Note
3	Cut the cable tie at the drive board.	 xx2000002058
4	Remove the protection plate.	 xx2100000301
5	Remove the cable support from the drive board by removing the attachment screws.	 xx2000002055
6	Disconnect the two connectors from the torque sensor board. <ul style="list-style-type: none">• TQ.A• TQ.B	 xx2000002053

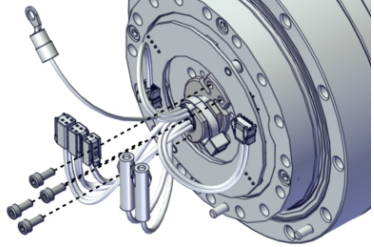

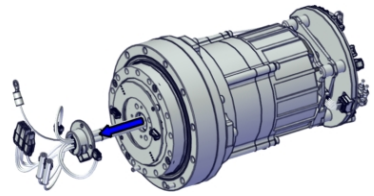
Continues on next page

	Action	Note
7	Remove the cable plate by removing the attachment screws.	 <p>xx2000002049</p>
8	<p>Remove the joint cable from the hollow shaft from the torque sensor side.</p> <p> CAUTION</p> <p>The connectors and the joint unit cables are sensitive to mechanical damage. Handle the assembly with care.</p>	 <p>xx2000002060</p>

Refitting the joint cabling

Use these procedures to refit the joint-5 cabling.

Refitting the joint cable

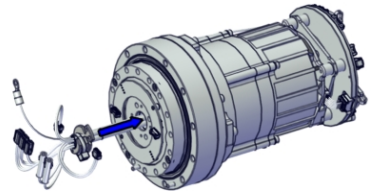
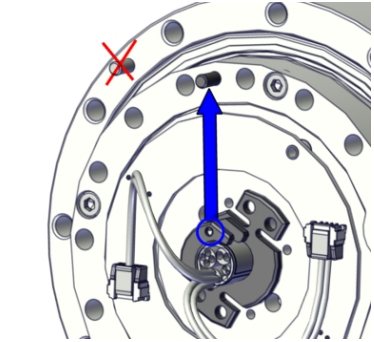
	Action	Note
1	<p> ELECTROSTATIC DISCHARGE (ESD)</p> <p>The unit is sensitive to ESD. Before handling the unit read the safety information in section The unit is sensitive to ESD on page 53.</p>	
2	<p>Place the joint cable through the hollow shaft from the torque sensor side.</p> <p> CAUTION</p> <p>The connectors and the joint unit cables are sensitive to mechanical damage. Handle the assembly with care.</p>	 <p>xx2000002048</p>
3	<p>Orient the cable plate according to the figure. The circle on the cable plate should point towards the guide pin on the torque sensor.</p>	 <p>xx2000002051</p>

Continues on next page

5 Repair

5.3.6 Replacing the axis-5 cabling

Continued

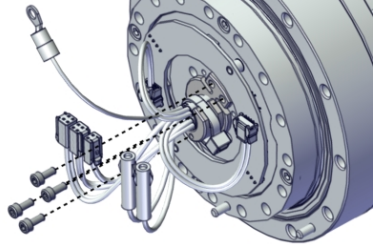
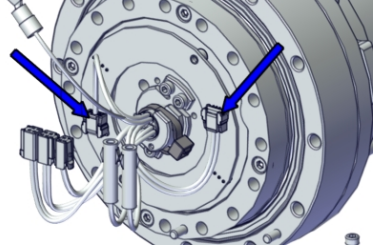
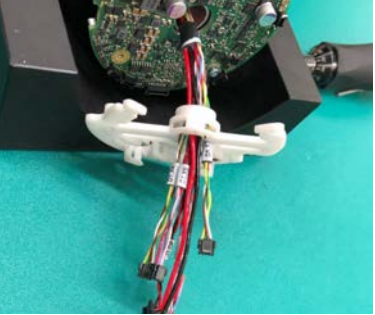
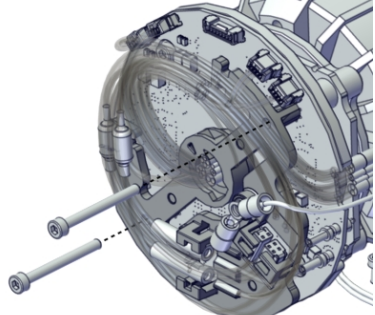
	Action	Note
4	Secure the cable plate to the joint unit with the attachment screws.	<p>Hex socket head cap screw: M2.5x6 12.9 Lafre 2C2B/FC6.9 (4 pcs) Tightening torque: 0.45 Nm.</p>  <p>xx2000002049</p>
5	Connect the two connectors to the torque sensor board. <ul style="list-style-type: none">• TQ.A to CH1/A• TQ.B to CH2/B	 <p>xx2000002053</p>
6	Insert the cabling through the cable support and fit the support to the drive board with the attachment screws.	 <p>xx2000002056</p> <p>Hex socket head cap screw: M3x30 12.9 Lafre 2C2B/FC6.9 (2 pcs) Tightening torque: 0.45 Nm.</p>  <p>xx2000002055</p>

Continues on next page

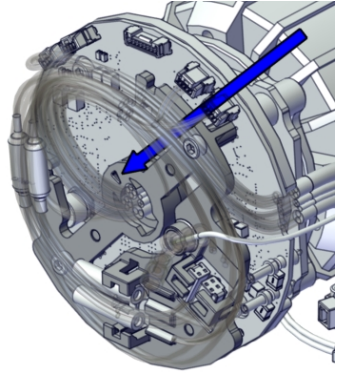
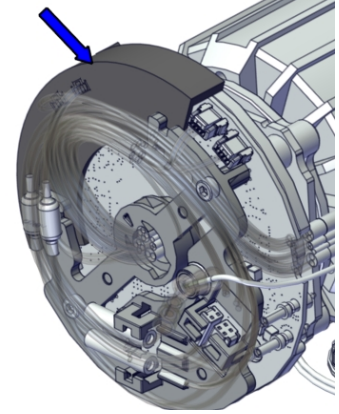
	Action	Note
7	<p>Keep the cabling loose, making sure not to twist or strain it.</p> <p>Use the cable tie to pre-fix the cable by hand.</p>	 <p>xx2100000507</p>
8	<p>Fit the protection plate to the drive board unit.</p>	<p>Protection plate: 3HAC077790-001 (for CRB 15000-5/0.95) / 3HAC087789-001 (for CRB 15000-10/1.52 and CRB 15000-12/1.27)</p>  <p>xx2000002057</p>

Continues on next page

5 Repair

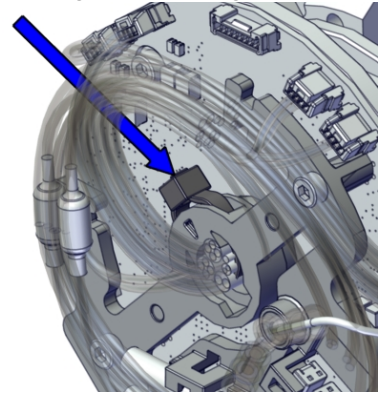
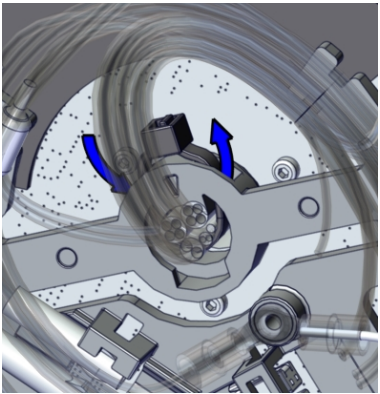
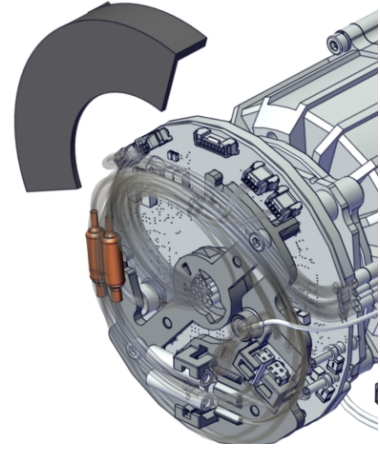

5.3.6 Replacing the axis-5 cabling

Continued

	Action	Note
9	Secure the cables to the cable support with a cable tie, using a cable tie gun. Assembly direction for the cable tie is shown in the figure.	<p>Cable tie: 3HAC075545-001. For securing joint unit cable. Cable tie gun EVO 7i Setting for cable tie gun: 6.75.</p>  <p>xx200002058</p>  <p>xx200002059</p>
10	Remove the protection plate.	 <p>xx210000301</p>

Continues on next page

Preparations before fitting the joint unit (-5/0.95)

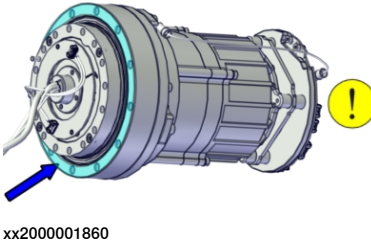
	Action	Note
1	 ELECTROSTATIC DISCHARGE (ESD) The unit is sensitive to ESD. Before handling the unit read the safety information in section <i>The unit is sensitive to ESD on page 53</i> .	
2	Clean the mounting surface of the joint unit and the mating surface on the casting with isopropanol. Joint unit mounting surface is pointed out in the figure.	Cleaning agent: Isopropanol Flange sealant: Loctite 574
3	Apply a thin layer of flange sealant to the mounting surface. Do not contaminate the radial sealing with sealant.  CAUTION The connectors and the joint unit cables are sensitive to mechanical damage. Handle the assembly with care.  ELECTROSTATIC DISCHARGE (ESD) The unit is sensitive to ESD. Before handling the unit read the safety information in section <i>The unit is sensitive to ESD on page 53</i> .	 xx2000001860

Refitting the axis-5 joint unit and transition cabling

	Action	Note
1	 CAUTION Axis-5 joint unit used for CRB 15000-5/0.95 has the same appearance as that used for CRB 15000-10/1.52 and CRB 15000-12/1.27. Do not mix the joint units for different manipulator variants. Always check the mark or label on the joint units before refitting.	

Continues on next page



5 Repair

5.3.6 Replacing the axis-5 cabling

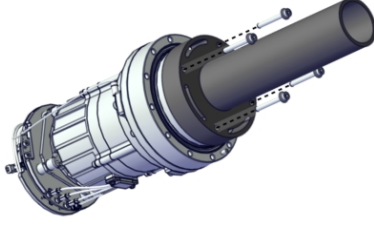
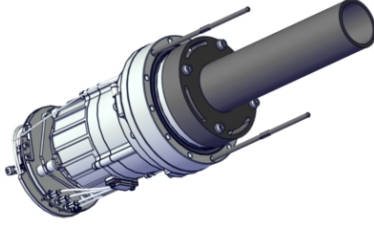
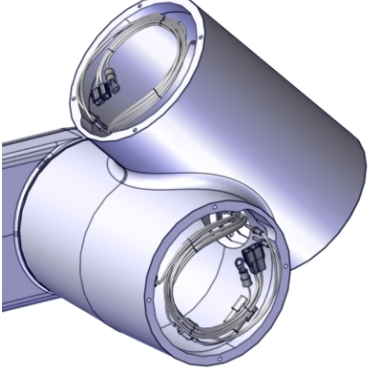
Continued

	Action	Note
2	<p>Fit the lifting aid to the joint unit.</p> <p> CAUTION</p> <p>The connectors and the joint unit cables are sensitive to mechanical damage. Handle the assembly with care.</p>	<p>Joint unit: 3HAC079143-001 (for CRB 15000-5/0.95) / 3HAC087546-001 (for CRB 15000-10/1.52 and CRB 15000-12/1.27)</p> <p>Lifting aid: 3HAC077789-001</p> <p>Screws: M3x12 (4 pcs)</p>  <p>xx2000001957</p>
3	<p>Fit two guide pins to the joint unit.</p>	<p>Guide pin, M3x110: 3HAC077787-001</p> <p>Always use guide pins in pairs.</p> <p>For joint units on axes 4, 5 and 6.</p>  <p>xx2000002438</p>
4	<p>Fit the transition cable between axis-5 and axis-6 joint units into the tilt.</p>	<p>Cable harness, transition joint-5 and joint-6: 3HAC083726-001</p>  <p>xx2100000040</p>

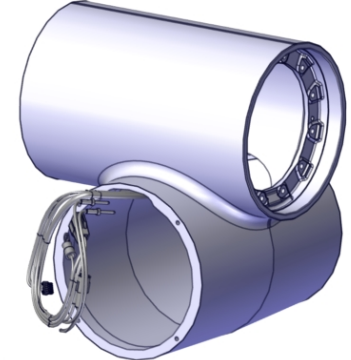
Continues on next page

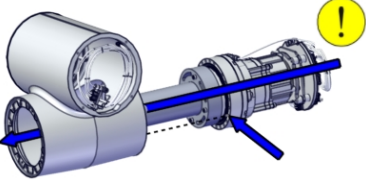
	Action	Note
5	Place the cabling at the slot before refitting the joint unit.	 <p>xx210000041</p>  <p>xx210000285</p>
6	<p>Fit the joint unit to the tilt, aligning the pin with the pin hole.</p> <p> CAUTION</p> <p>The connectors and the joint unit cables are sensitive to mechanical damage. Handle the assembly with care.</p>	 <p>xx2000002142</p>

Continues on next page

5 Repair

5.3.6 Replacing the axis-5 cabling

Continued

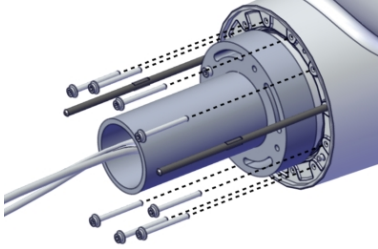
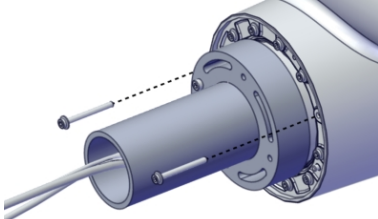
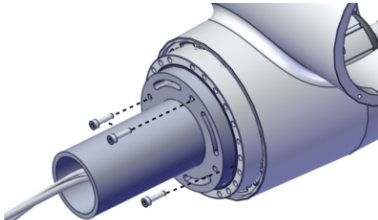
	Action	Note
7	Secure the joint unit with new attachment screws.	<p>Flange socket head screw with glue: 3HAB3413-330 M3x30 12.9 Lafre 2C2B/FC6.9+PrO-COat111, with NYPLAS glue , 12 pcs Used for joint unit of CRB 15000-5/0.95.</p> <p>Always use new screws when refitting a joint unit. If ordering a new joint unit spare part, new screws are included.</p>  <p>xx2100000333</p>
8	Remove the guide pins and secure the remaining two attachment screws.	 <p>xx2000002140</p>
9	Pre-tighten the screws crosswise.	
10	Torque tighten all screws crosswise.	<p>Tightening torque: 1.4 Nm (for CRB 15000-5/0.95) / 1.9 Nm (for CRB 15000-10/1.52 and CRB 15000-12/1.27)</p>
11	Remove the lifting aid by removing the screws.	 <p>xx2000002139</p>
12	Clean pushed-out flange sealant, if any.	

Continues on next page

Connecting the axis-5 joint unit cabling

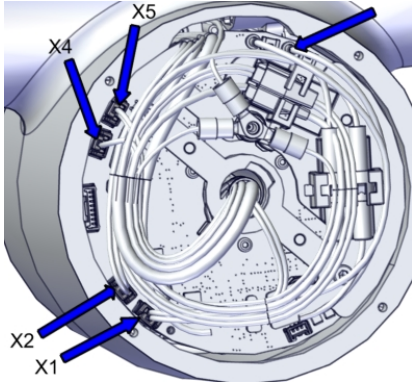
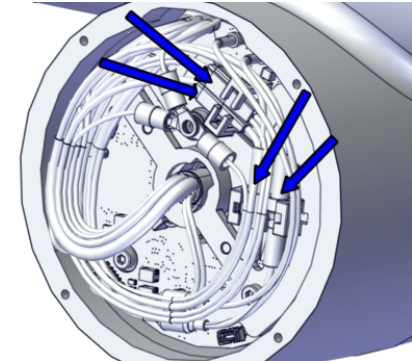
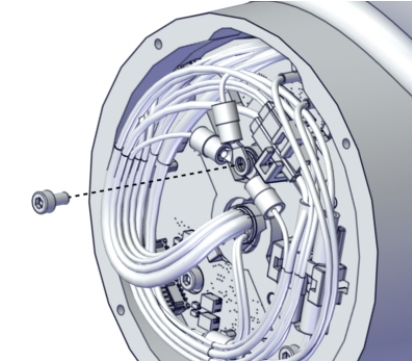
	Action	Note
1	<p>Reconnect the connectors to the drive board.</p> <ul style="list-style-type: none"> • D4/5.X1 to X1 • D5.DC+ to +DC • D5.DC- to Ground • D4/5.X4 to X4 • D5/4.X2 to X2 • D4/5.X5 to X5 	 <p>xx2000002138</p>
2	<p>Connect the connectors to each other and snap them to the cable holders.</p> <ul style="list-style-type: none"> • J5/6.DC+ to J6.DC+ • J5/6.DC- to J6.DC- • J5/6.CS to J6.CS • J5/6.CP to J6.CP 	 <p>xx2000002137</p>
3	<p>Secure the cables for functional earth and protective earth with a screw.</p>	<p>Hex socket head cap screw: M3x6 (1 pcs). Tightening torque: 0.8 Nm.</p>  <p>xx2000002136</p>

Continues on next page

5 Repair

5.3.6 Replacing the axis-5 cabling

Continued

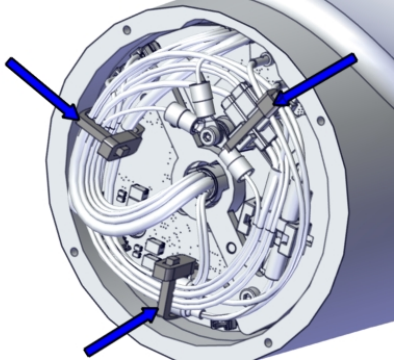
	Action	Note
4	Secure the cabling with cable ties.	Cable ties (3 pcs)  <small>xx2000002135</small>

Refitting the axis-5 cover

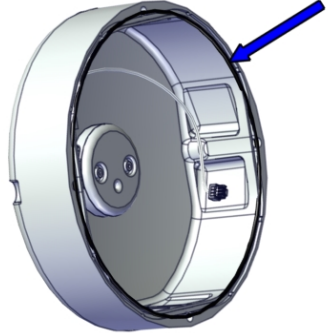
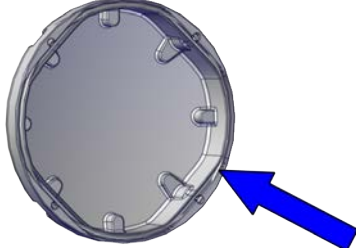
	Action	Note
1	Fit the o-ring to its groove. Replace if damaged.	Valid for CRB 15000-5/0.95 O-ring: 3HAC061327-051  <small>xx2000001962</small> Valid for CRB 15000-10/1.52 and CRB 15000-12/1.27 O-ring: 3HAC061327-051  <small>xx2300000849</small>

Continues on next page

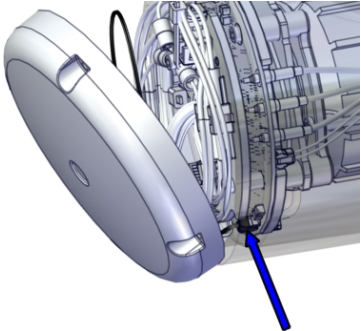
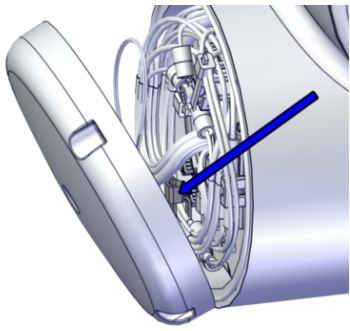
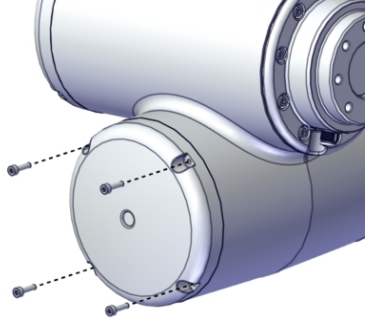
	Action	Note
2	<p>For robots with RobotWare earlier than 7.10 Place the cover at mounting position and reconnect the brake release connector DR.X8 to the drive board.</p>	 <p>xx2000002134</p>
3	<p>For robots with RobotWare earlier than 7.10 Secure the brake release cable with a cable tie.</p>	<p>Cable ties</p>  <p>xx2000002133</p>
4	<p>Refit the cover with the four screws.</p>	<p>Valid for CRB 15000-5/0.95 Hex socket head cap screw: M3x8 12.9 Lafre 2C2B/FC6.9 (4 pcs) Tightening torque: 0.2 Nm</p> <p>Valid for CRB 15000-10/1.52 and CRB 15000-12/1.27 Hex socket head cap screw: M3x12 12.9 Lafre 2C2B/FC6.9 (4 pcs) Tightening torque: 1.4 Nm</p>  <p>xx2000002132</p>



Continues on next page

5 Repair

5.3.6 Replacing the axis-5 cabling

Continued

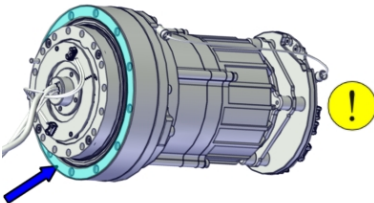

Preparations before fitting the joint unit (-5/0.95)

	Action	Note
1	 ELECTROSTATIC DISCHARGE (ESD) The unit is sensitive to ESD. Before handling the unit read the safety information in section <i>The unit is sensitive to ESD on page 53</i> .	
2	Clean the mounting surface of the joint unit and the mating surface on the casting with isopropanol. Joint unit mounting surface is pointed out in the figure.	Cleaning agent: Isopropanol Flange sealant: Loctite 574
3	Apply a thin layer of flange sealant to the mounting surface. Do not contaminate the radial sealing with sealant.  CAUTION The connectors and the joint unit cables are sensitive to mechanical damage. Handle the assembly with care.  ELECTROSTATIC DISCHARGE (ESD) The unit is sensitive to ESD. Before handling the unit read the safety information in section <i>The unit is sensitive to ESD on page 53</i> .	 xx2000001860

Refitting the axis-6 joint unit

	Action	Note
1	 CAUTION Axis-6 joint unit used for CRB 15000-5/0.95 has the same appearance as that used for CRB 15000-10/1.52 and CRB 15000-12/1.27. Do not mix the joint units for different manipulator variants. Always check the mark or label on the joint units before refitting.	

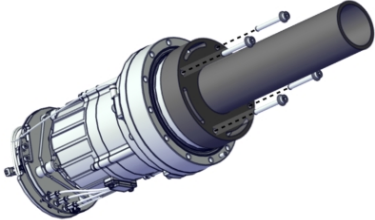
Continues on next page

	Action	Note
2	<p>Fit the lifting aid to the joint unit.</p> <p> CAUTION</p> <p>The connectors and the joint unit cables are sensitive to mechanical damage. Handle the assembly with care.</p>	<p>Joint unit: 3HAC079143-001 (for CRB 15000-5/0.95) / 3HAC087546-001 (for CRB 15000-10/1.52 and CRB 15000-12/1.27)</p> <p>Lifting aid: 3HAC077789-001</p> <p>Screws: M3x12 (4 pcs)</p>  <p>xx2000001957</p>
3	<p>Fit two guide pins to the joint unit.</p>	<p>Guide pin, M3x110: 3HAC077787-001</p> <p>Always use guide pins in pairs.</p> <p>For joint units on axes 4, 5 and 6.</p>  <p>xx2000002438</p>
4	<p>Place the cabling at the slot before refitting the joint unit.</p>	 <p>xx2100000041</p>

Continues on next page

5 Repair

5.3.6 Replacing the axis-5 cabling

Continued

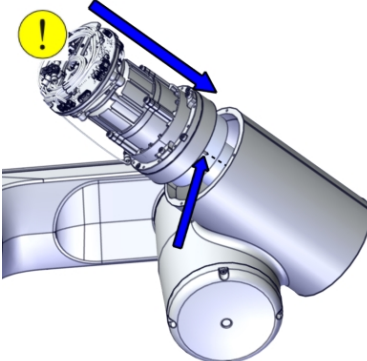
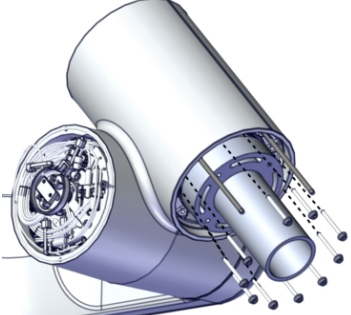
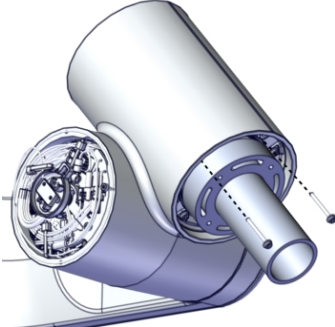
	Action	Note
5	<p>Fit the joint unit to the tilt, aligning the pin with the pin hole.</p> <p> CAUTION</p> <p>The connectors and the joint unit cables are sensitive to mechanical damage. Handle the assembly with care.</p>	 <p>xx2000002195</p>
6	<p>Secure the joint unit with new attachment screws.</p>	<p>Flange socket head screw with glue: 3HAB3413-330 M3x30 12.9 Lafre 2C2B/FC6.9+PrO-COat111, with NYPLAS glue , 12 pcs Used for joint unit of CRB 15000-5/0.95.</p> <p>Always use new screws when refitting a joint unit. If ordering a new joint unit spare part, new screws are included.</p>  <p>xx2100000329</p>
7	<p>Remove the guide pins and secure the remaining two attachment screws.</p>	 <p>xx2000002170</p>
8	<p>Pre-tighten the screws crosswise.</p>	
9	<p>Torque tighten all screws crosswise.</p>	<p>Tightening torque: 1.4 Nm (for CRB 15000-5/0.95) / 1.9 Nm (for CRB 15000-10/1.52 and CRB 15000-12/1.27)</p>

Continues on next page

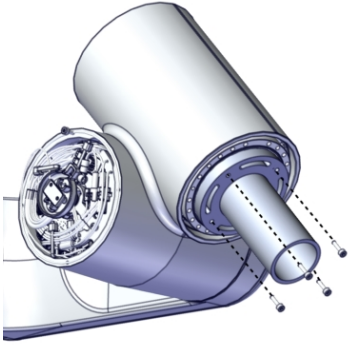
	Action	Note
10	Remove the lifting aid by removing the screws.	 <p>xx2000002168</p>
11	Clean pushed-out flange sealant, if any.	

Connecting the axis-6 joint unit cabling

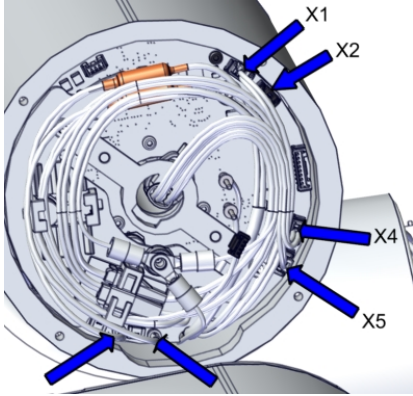
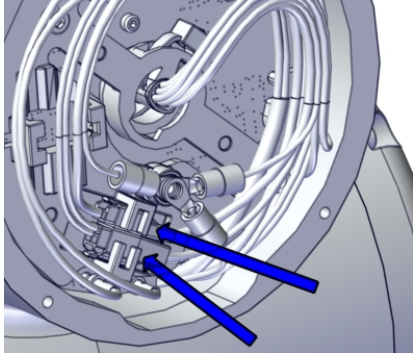
	Action	Note
1	Reconnect the connectors to the drive board. <ul style="list-style-type: none"> • D6.X1 to X1 • D6.DC+ to +DC • D6.DC- to Ground • D6.X4 to X4 • D6.X2 to X2 • D6.X5 to X5 	 <p>xx2000002164</p>
2	Connect the connectors to each other and snap them to the cable holders. <ul style="list-style-type: none"> • J7.CS to J7.CS • J7.CP to J7.CP 	 <p>xx2000002163</p>

Continues on next page

5 Repair

5.3.6 Replacing the axis-5 cabling

Continued

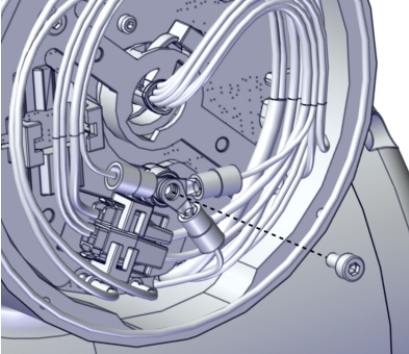
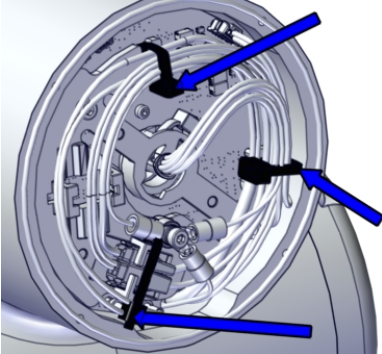
	Action	Note
3	Secure the cables for functional earth and protective earth with a screw.	<p>Hex socket head cap screw: M3x6 (1 pcs).</p> <p>Tightening torque: 0.8 Nm.</p>  <p>xx2000002162</p>
4	Secure the cabling with cable ties.	<p>Cable ties (3 pcs)</p>  <p>xx2000002161</p>

Refitting the arm-side interface

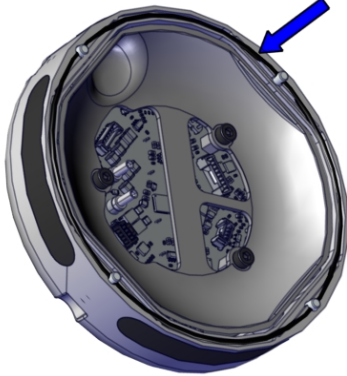
	Action	Note
1	Fit the o-ring to its groove. Replace if damaged.	<p>O-ring: 3HAC061327-051</p>  <p>xx2000002551</p>

Continues on next page

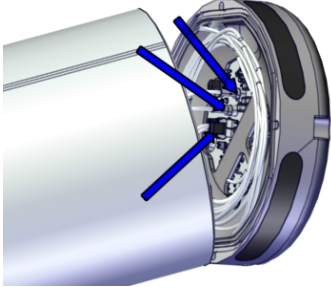
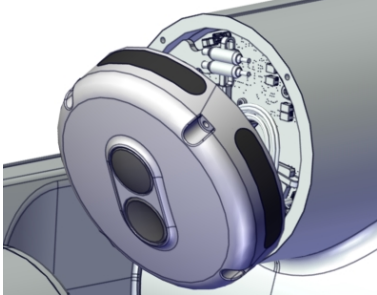
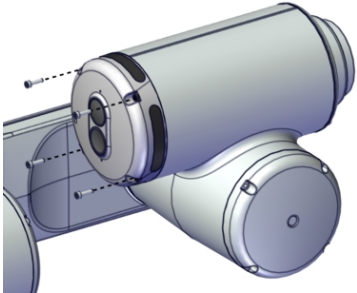
	Action	Note
2	<p>Place the arm-side interface at mounting position and reconnect the connectors.</p> <ul style="list-style-type: none"> • ASI.DC+ • ASI.DC- • ASI.X1 <p>The correct orientation of the arm-side interface is with the convex button in upper position.</p> <p> Note</p> <p>Do not leave the arm-side interface in location without being secured with the attachment screws.</p>	 <p>xx2100000335</p>  <p>xx2100000336</p>
3	<p>Refit the arm-side interface with four screws.</p>	<p>Valid for CRB 15000-5/0.95 Hex socket head cap screw: M3x30 12.9 Lafre 2C2B/FC6.9 (4 pcs) Tightening torque: 0.45 Nm</p> <p>Valid for CRB 15000-10/1.52 and CRB 15000-12/1.27 Hex socket head cap screw: M3x20 12.9 Lafre 2C2B/FC6.9 (4 pcs) Tightening torque: 0.45 Nm</p>  <p>xx2000002550</p>

Continues on next page

5 Repair

5.3.6 Replacing the axis-5 cabling

Continued

Refitting the tool flange adapter

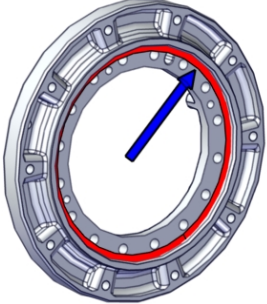
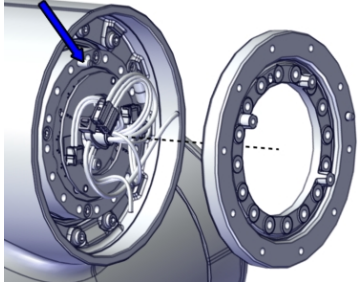
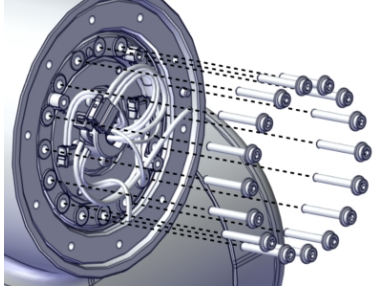
	Action	Note
1	Clean the mounting surface with isopropanol. Apply flange sealant to the corner of the adapter mounting surface, as pointed out in the figure.	<p>Cleaning agent: Isopropanol Flange sealant: Loctite 574</p>  <p>xx2000002196</p>
2	Refit the tool flange adapter, aligning the pin with the pin hole.	<p>Axis-6 inner flange: 3HAC073952-001</p>  <p>xx2000002167</p>
3	Secure with screws.	<p>Flange socket head screw: M3x20 12.9 Lafre 2C2B/FC6.9+PrO-COat111 (16 pcs) Tightening torque: 1.8 Nm.</p>  <p>xx2000002165</p>

Continues on next page

Connecting the tool flange functional earth cable

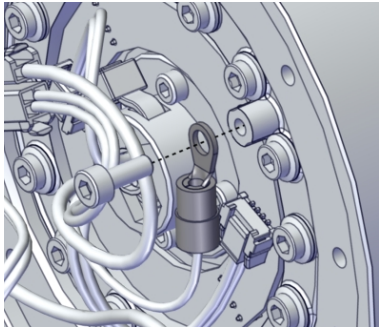
	Action	Note
1	Secure the cable for functional earth to the tool flange adapter with a screw.	 <p>xx2000002159</p>

Refitting the tool flange

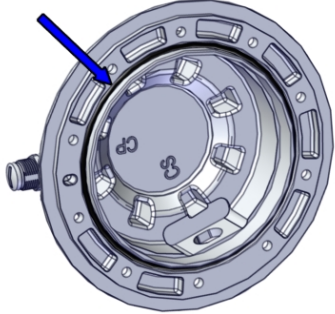
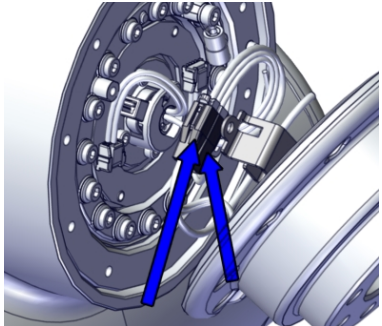
	Action	Note
1	Check the o-ring on the tool flange and lubricate with grease. Replace if damaged.	<p>Axis-6 flange: 3HAC073953-001 O-ring: 3HAB3772-182 Grease: 3HAC042536-001 (Shell Gadus S2)</p>  <p>xx2000002197</p>
2	Place the tool flange at mounting position and reconnect the CP/CS connectors.	 <p>xx2000002158</p>

Continues on next page

5 Repair

5.3.6 Replacing the axis-5 cabling

Continued

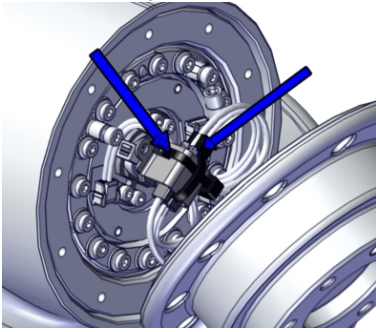
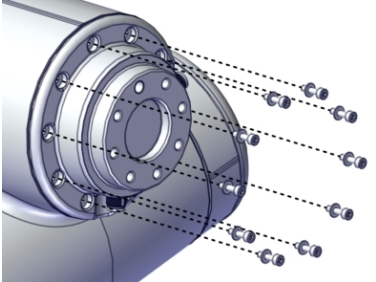
	Action	Note
3	Fit the connectors to the cable bracket and secure the connectors with two cable ties.	<p>Cable ties (2 pcs)</p>  <p>xx2000002157</p>
4	Refit and secure the tool flange with screws and washers.	<p>Hex socket head cap screw: M3x12 12.9 Lafre 2C2B/FC6.9 (10 pcs) Spring washer: 7x3.2x0.6 Steel (10 pcs) Tightening torque: 1.8 Nm.</p>  <p>xx2000002155</p>

Refitting the tilt

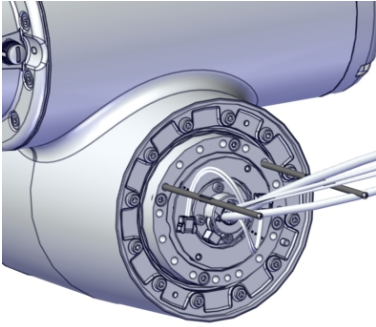
	Action	Note
1	Fit two guide pins to the axis-5 joint.	<p>Guide pin, M3x110: 3HAC077787-001 Always use guide pins in pairs.</p>  <p>xx2000002146</p>

Continues on next page

5.3.6 Replacing the axis-5 cabling
Continued

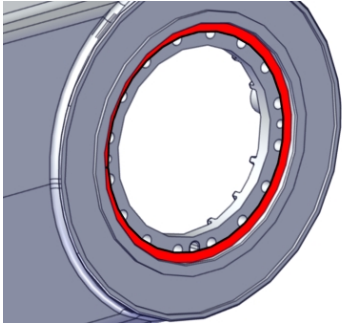
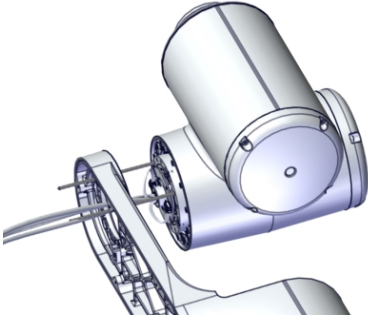
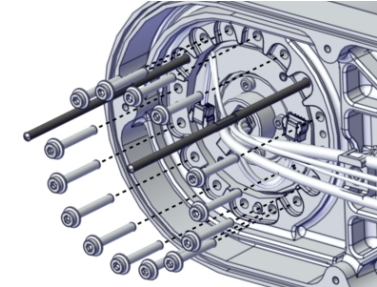
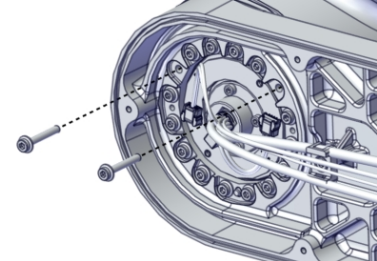
	Action	Note
2	Clean the mounting surface with isopropanol. Apply flange sealant to the corner of the tubular mounting surface, as pointed out in the figure.	<p>Cleaning agent: Isopropanol Flange sealant: Loctite 574</p>  <p>xx2000002147</p>
3	Lift the tilt into mounting position while inserting the cabling into the tubular.	 <p>xx2000002131</p>
4	Slide the tilt into place on the guide pins.	
5	Secure the tilt to the tubular with all attachment screws but two. Pre-tighten the screws crosswise firstly.	<p>Flange socket head screw: M3x20 12.9 Lafre 2C2B/FC6.9+PrO-COat111 (14 pcs)</p>  <p>xx2000002130</p>
6	Remove the guide pins and fasten the remaining two screws.	<p>Flange socket head screw: M3x20 12.9 Lafre 2C2B/FC6.9+PrO-COat111 (2 pcs)</p>  <p>xx2000002128</p>
7	Torque tighten all screws crosswise.	Tightening torque: 1.8 Nm.

Continues on next page

5 Repair

5.3.6 Replacing the axis-5 cabling

Continued

Connecting the tilt cabling

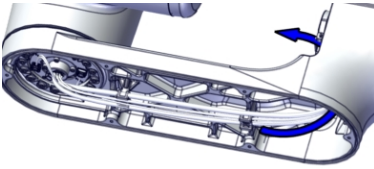
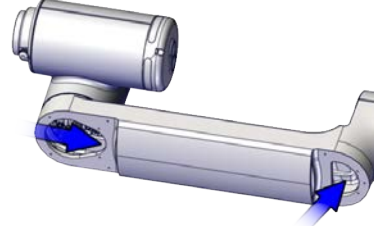
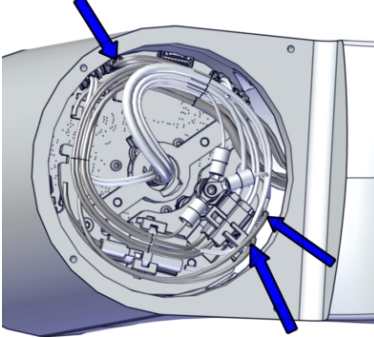
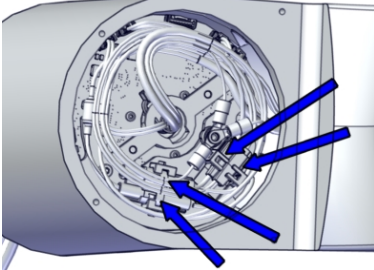
	Action	Note
1	Insert the cabling into the tubular.	<p>Valid for CRB 15000-5/0.95</p>  <p>xx2000002148</p> <p>Valid for CRB 15000-10/1.52 and CRB 15000-12/1.27</p>  <p>xx2300000845</p>
2	<p>Reconnect the connectors to the drive board.</p> <ul style="list-style-type: none"> • D3/4.X2 to X2 • D3/4.DC- to Ground • D3/4.DC+ to +DC 	 <p>xx2000002125</p>
3	<p>Connect the connectors to each other and snap them to the cable holders.</p> <ul style="list-style-type: none"> • J4/5.DC+ to J5/6.DC+ • J4/5.DC- to J5/6.DC- • J4/5.CS to J5/6.CS • J4/5.CP to J5/6.CP 	 <p>xx2000002089</p>

Continues on next page

5.3.6 Replacing the axis-5 cabling
Continued

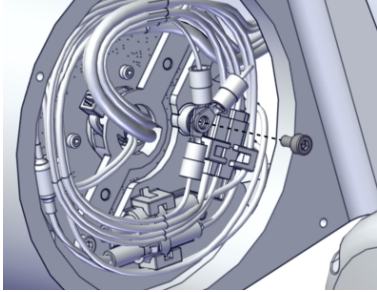
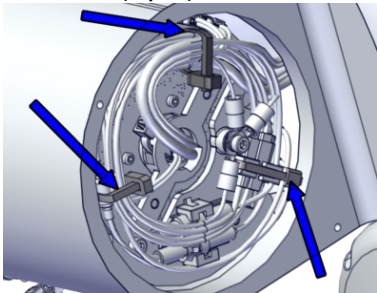
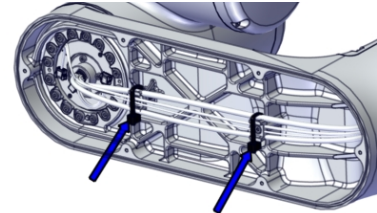
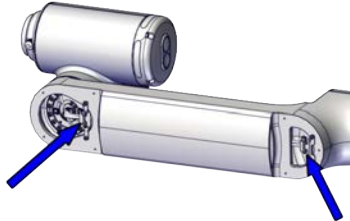
	Action	Note
4	Secure the cables for functional earth and protective earth with a screw.	<p>Hex socket head cap screw: M3x6 (1 pcs). Tightening torque: 0.8 Nm.</p>  <p>xx2000002087</p>
5	Secure the cabling to joint unit with cable ties.	<p>Cable ties (3 pcs)</p>  <p>xx2000002086</p>
6	Secure the cabling to tubular with cable ties.	<p>Cable ties (2 pcs) Valid for CRB 15000-5/0.95</p>  <p>xx2000002124</p> <p>Valid for CRB 15000-10/1.52 and CRB 15000-12/1.27</p>  <p>xx2300000842</p>

Continues on next page

5 Repair

5.3.6 Replacing the axis-5 cabling

Continued

Refitting the tubular cover (-5/0.95)

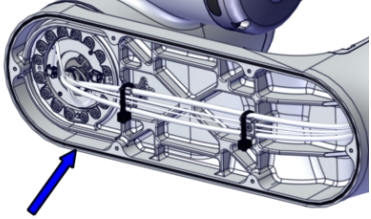
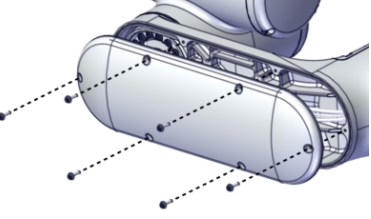
	Action	Note
1	Wipe, lubricate and fit the o-ring to its groove. Replace if damaged.	<p>O-ring: 3HAC061327-043 Grease: 3HAC042536-001 (Shell Gadus S2)</p>  <p>xx2000002149</p>
2	Refit the cover with new attachment screws.	<p>Flange socket head screw with glue: 3HAB3413-312 M3x12 12.9 Lafre 2C2B/FC6.9+PrO-COat111, with NYPLAS glue For tubular cover of CRB 15000-5/0.95. Always use new screws. If ordering a new axis-4 or axis-5 joint unit spare part, new screws for the tubular cover are included. Tightening torque: 1.6 Nm.</p>  <p>xx2000002123</p>

Continues on next page

Refitting the tubular cover (-10/1.52 and -12/1.27)

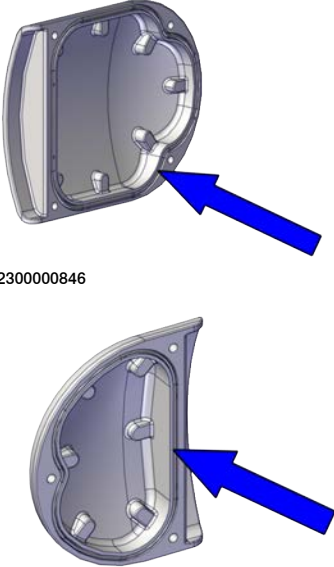
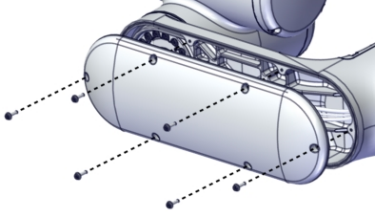
	Action	Note
1	Wipe, lubricate and fit the o-ring to its groove. Replace if damaged.	<p>O-ring: 3HAC061327-076 O-ring: 3HAB3772-166 Grease: 3HAC042536-001 (Shell Gadus S2)</p>  <p>xx2300000846</p> <p>xx2300000847</p>
2	Refit the covers with new attachment screws.	<p>Hex socket head cap screw: 3HAB3409-224 M3x12 12.9 Lafre 2C2B/FC6.9 (3 pcs) Tightening torque: 1.4 Nm.</p>  <p>xx2000002123</p>

Continues on next page

5 Repair

5.3.6 Replacing the axis-5 cabling

Continued

Refitting the axis-4 cover

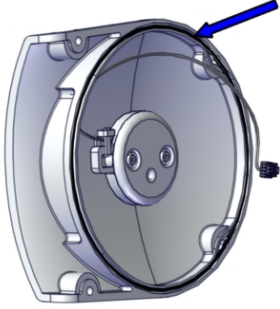
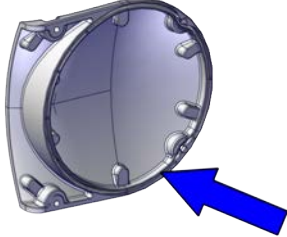
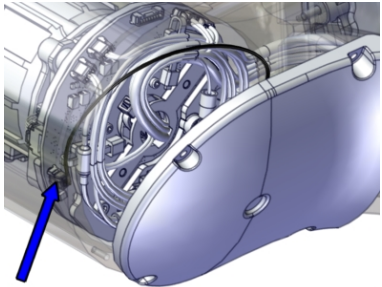
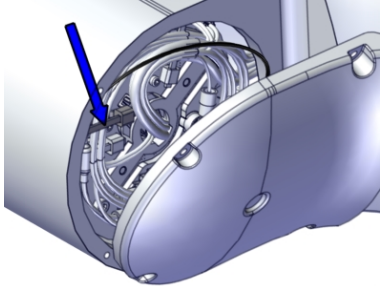
	Action	Note
1	Fit the o-ring to its groove. Replace if damaged.	<p>Valid for CRB 15000-5/0.95 O-ring: 3HAC061327-051</p>  <p>xx200002092</p> <p>Valid for CRB 15000-10/1.52 and CRB 15000-12/1.27 O-ring: 3HAC061327-051</p>  <p>xx2300000848</p>
2	For robots with RobotWare earlier than 7.10 Place the cover at mounting position and reconnect the brake release connector DR.X8 to the drive board.	<p>Tweezers</p>  <p>xx200002085</p>
3	For robots with RobotWare earlier than 7.10 Secure the brake release cable with a cable tie.	<p>Cable ties</p>  <p>xx200002084</p>

Continues on next page

5.3.6 Replacing the axis-5 cabling
Continued

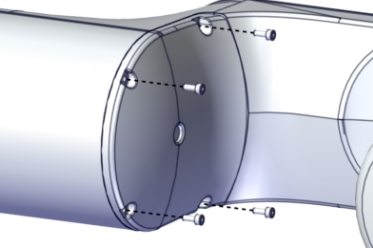
	Action	Note
4	Refit the cover with the four screws.	<p>Hex socket head cap screw: M3x8 12.9 Lafre 2C2B/FC6.9 (4 pcs)</p> <p>Tightening torque: 0.2 Nm (for CRB 15000-5/0.95) / 0.9 Nm (for CRB 15000-10/1.52 and CRB 15000-12/1.27)</p> <p>Tightening torque: 0.9 Nm</p>  <p>xx2000002083</p>

Concluding procedure

	Action	Note
1	<p>Calibrate the joint unit torque sensor.</p> <ol style="list-style-type: none"> 1 On the FlexPendant, go to the Code app and call the calibration procedure using PP to Routine, not by using Call Routine. 2 Select the Joint Unit Replacement feature and then select the axis to calibrate. 3 The controller is now restarted. Once the home screen of the FlexPendant is shown, press the Play button to continue the calibration routine. 4 The robot moves to a position or positions where measurements are performed. 5 The results of the measurements are presented together with the current values in the controller. Choose whether to save the calibration data or not. 6 If new calibration data is saved you will be asked to do a test with the lead-through functionality active to verify that the sensors work correctly. 7 Finally the robot is moved back to the original position. 8 Test the brake release (movement without drive power) functionality, see Testing the brake release functionality on page 196. 	See Calibration on page 1063
2	 <p>DANGER</p> <p>Make sure all safety requirements are met when performing the first test run. See Test run after installation, maintenance, or repair on page 90.</p>	

5 Repair

5.3.7 Replacing the axis-6 cabling

5.3.7 Replacing the axis-6 cabling

Location of the cable harness

The cable harness is located as shown in the figure.

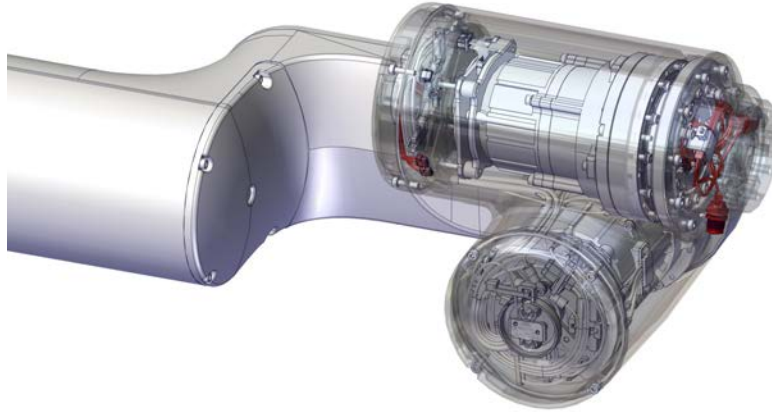

xx210000062

Summary of the replacement procedure

This is a brief summary of the replacement procedure, containing the major actions to be performed.

- 1 Remove the tool flange.
- 2 Remove the tool flange adapter.
- 3 Remove the axis-6 cover.
- 4 Remove the axis-6 joint unit.
- 5 Replace the cabling.

Required spare parts



Note

The spare part numbers that are listed in the table can be out of date. See the latest spare parts of the CRB 15000 via myABB Business Portal, www.abb.com/myABB.

Spare part	Article number	Note
Cable harness, joint 6	3HAC073208-001	Also order new Cable tie: 3HAC075545-001.
Cable tie	3HAC075545-001	For securing joint unit cable.

Continues on next page

Required tools and equipment

Equipment	Article number	Note
Lifting aid	3HAC077789-001	For joint units on axes 4, 5 and 6. Attachment screws M3x12 (4 pcs) are enclosed.
Guide pin, M3x110	3HAC077787-001	Always use guide pins in pairs. For joint units on axes 4, 5 and 6.
Tweezers	-	Used to handle drive board connectors.
Protection plate	3HAC077790-001	For protection of drive board during cabling installation on joint units of CRB 15000-5/0.95.
Cable tie gun EVO 7i	-	HellermannTyton 110-77001 or similar
Standard toolkit	-	Content is defined in section Standard toolkit on page 1099 .

Required consumables

Consumable	Article number	Note
Cable ties	-	
O-ring	3HAC061327-051	Arm-side interface Replace if damaged.
O-ring	3HAB3772-182	Tool flange
Grease	3HAC042536-001	Shell Gadus S2
Cleaning agent	-	Isopropanol
Flange sealant	-	Loctite 574

Removing the joint cabling

Use these procedures to remove the joint-6 cabling.

Preparations before removing the cabling

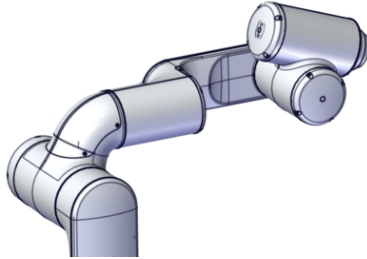
	Action	Note
1	<p>Jog the robot to the specified position:</p> <ul style="list-style-type: none"> • Axis 1: No significance. • Axis 2: No significance. • Axis 3: No significance. • Axis 4: No significance. • Axis 5: approximately +20° • Axis 6: 0° (home position) <p> CAUTION</p> <p>Jog the axis on which the joint unit is to be replaced to home position, to achieve correct cable routing during replacement of the joint unit.</p>	<p>Example of CRB 15000-5/0.95, similar to CRB 15000-10/1.52 and CRB 15000-12/1.27.</p>  <p>xx2100000043</p>

Continues on next page



5 Repair

5.3.7 Replacing the axis-6 cabling

Continued

	Action	Note
2	 CAUTION Turn off all supplies for electrical power to the robot, before starting the repair work.	

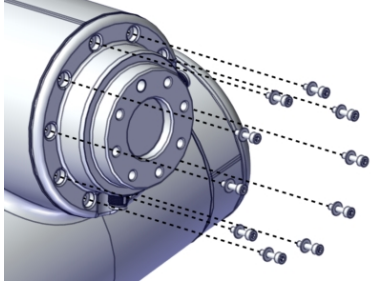
Removing the tool flange

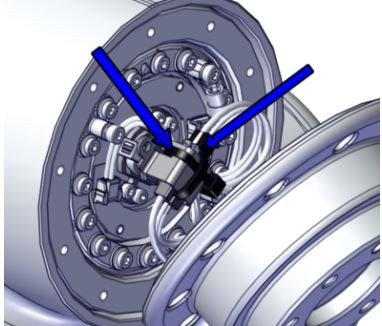
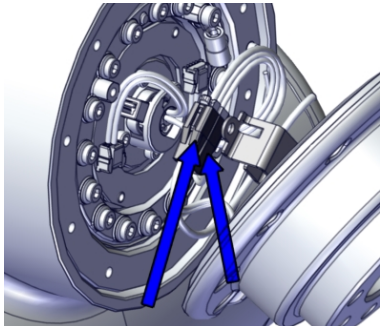
	Action	Note
1	Remove the tool flange screws and washers.	 xx2000002155
2	 CAUTION Valid for CRB 15000-5/0.95 There is cabling connected between the cover and the joint unit drive board. Open the cover with care to avoid damage to the cabling or the connector(s). Do not leave the cover in location without being secured with the attachment screws.	
3	Cut the cable ties.	 xx2000002157
4	Disconnect the CP/CS connectors from the drive board and remove the tool flange.	 xx2000002158

Continues on next page

Disconnecting the tool flange functional earth cable

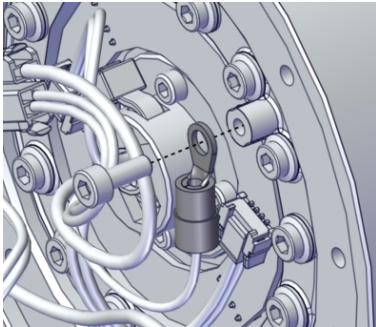
	Action	Note
1	Remove the functional earth cable by removing the screw.	 <p>xx2000002159</p>

Removing the tool flange adapter

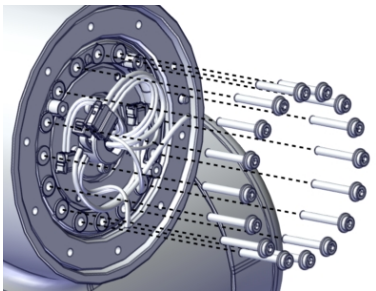
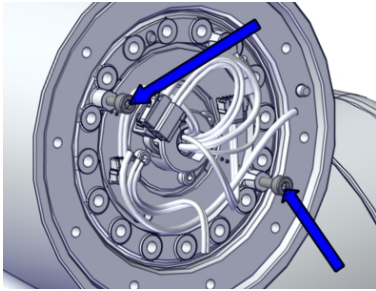
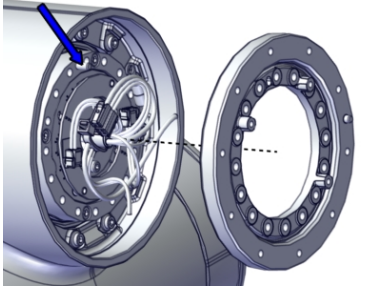
	Action	Note
1	Remove the tool flange adapter screws.	 <p>xx2000002165</p>
2	Press the adapter out of position by using two of the attachment screws as removal tools.	 <p>xx2000002166</p>
3	Remove the tool flange adapter.	 <p>xx2000002167</p>



Continues on next page

5 Repair

5.3.7 Replacing the axis-6 cabling

Continued

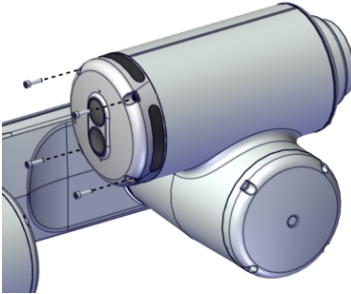
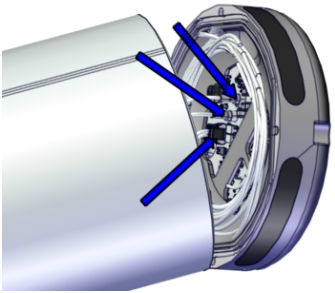

Removing the arm-side interface

	Action	Note
1	 CAUTION Make sure that all supplies for electrical power are turned off.	
2	 CAUTION There is cabling connected between the arm-side interface and the joint unit drive board. Open the arm-side interface with care to avoid damage to the cabling or the connector(s). Do not leave the arm-side interface in location without being secured with the attachment screws.	
3	Remove the attachment screws.	 xx2000002550
4	Loosen the arm-side interface carefully and disconnect the connectors from it. <ul style="list-style-type: none"> • ASI.DC+ • ASI.DC- • ASI.X1 	 xx2100000335

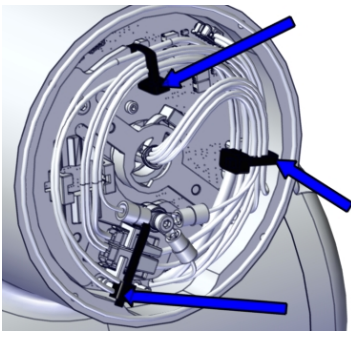
Disconnecting the axis-6 joint unit cabling

	Action	Note
1	Cut the cable ties.	 xx2000002161

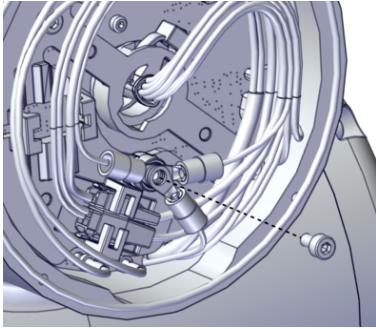
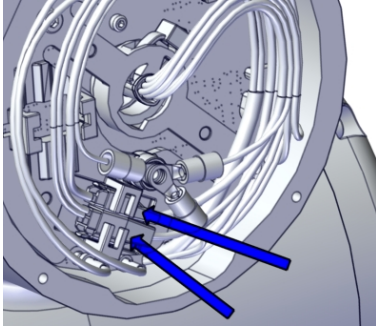
Continues on next page

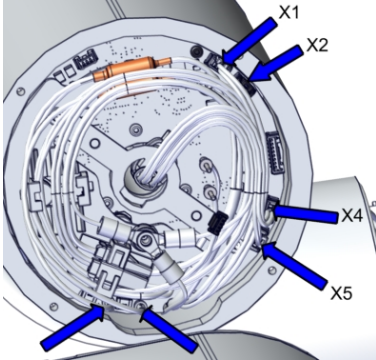
	Action	Note
2	Remove the functional and protective earth cables by removing the screw.	 <p>xx2000002162</p>
3	Snap loose and disconnect the connectors: <ul style="list-style-type: none"> • J7.CS • J7.CP 	 <p>xx2000002163</p>
4	Disconnect the connectors from the drive board. <ul style="list-style-type: none"> • D6.X1 • D6.DC+ • D6.DC- • D6.X4 • D6.X2 • D6.X5 <p> CAUTION</p> <p>Use tweezers to unlock connectors and pull them off.</p>	<p>Tweezers</p>  <p>xx2000002164</p>

Continues on next page

5 Repair



5.3.7 Replacing the axis-6 cabling

Continued

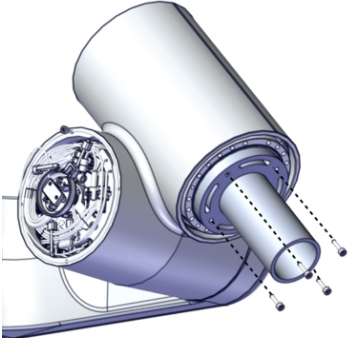
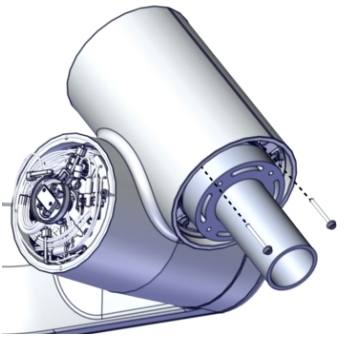
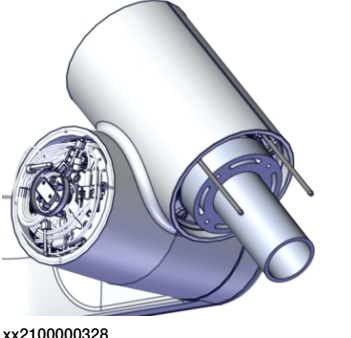
Removing the axis-6 joint unit

	Action	Note
1	<p>Fit the lifting aid to the joint unit, on the torque sensor side.</p> <p> CAUTION</p> <p>The connectors and the joint unit cables are sensitive to mechanical damage. Handle the assembly with care.</p>	<p>Lifting aid: 3HAC077789-001 Screws: M3x12 (4 pcs)</p>  <p>xx2000002168</p> <p>Position shown in the figure shows axis 5 jogged to +20°, which is a more convenient position when replacing only the axis-6 joint unit.</p>
2	<p>Remove two attachment screws. Dispose the screws. New screws are included in the spare part delivery of the joint unit.</p>	 <p>xx2000002170</p> <p>Position shown in the figure shows axis 5 jogged to +20°, which is a more convenient position when replacing only the axis-6 joint unit.</p>
3	<p>Fit two guide pins to the axis-6 joint unit.</p>	<p>Guide pin, M3x110: 3HAC077787-001 Always use guide pins in pairs. For joint units on axes 4, 5 and 6.</p>  <p>xx2100000328</p>

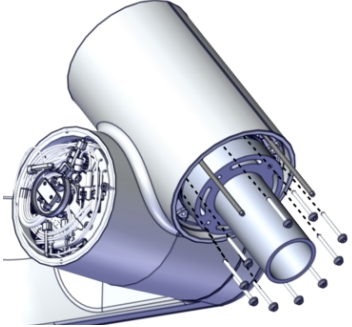
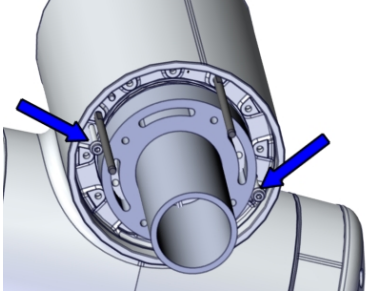
Continues on next page

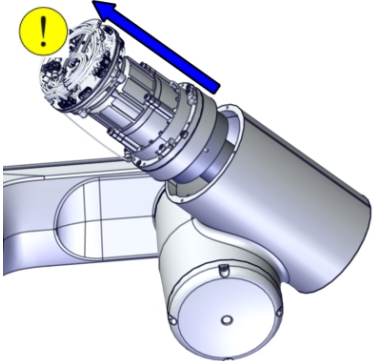
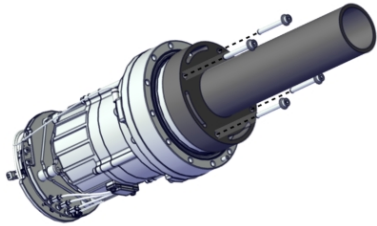
	Action	Note
4	<p>Remove the remaining attachment screws. Use two screws as press out screws in the upcoming step, then dispose all screws. New screws are included in the spare part delivery of the joint unit.</p>	 <p>xx2100000329</p>
5	<p>Press the joint unit out of position using two of the previous attachment screws as removal tools.</p>	 <p>xx2100000330</p>
6	<p>Remove the joint unit from the tubular.</p> <p> CAUTION</p> <p>The connectors and the joint unit cables are sensitive to mechanical damage. Handle the assembly with care.</p>	 <p>xx2000002169</p> <p>Position shown in the figure shows axis 5 jogged to +20°, which is a more convenient position when replacing only the axis-6 joint unit.</p>
7	<p>Remove the lifting aid and guide pins.</p>	 <p>xx2000001957</p>



Continues on next page

5 Repair

5.3.7 Replacing the axis-6 cabling

Continued

Removing the joint cable

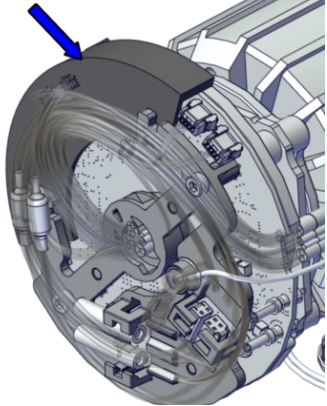
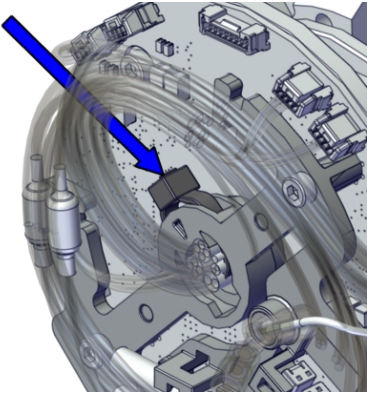
	Action	Note
1	 ELECTROSTATIC DISCHARGE (ESD) The unit is sensitive to ESD. Before handling the unit read the safety information in section <i>The unit is sensitive to ESD on page 53</i> .	
2	Fit the protection plate to the drive board unit.  Tip Using the protection plate is important for protecting the drive board unit. If complete joint unit is to be replaced, the protection plate is not needed.	Protection plate: 3HAC077790-001 (for CRB 15000-5/0.95) / 3HAC087789-001 (for CRB 15000-10/1.52 and CRB 15000-12/1.27)  xx2000002057
3	Cut the cable tie at the drive board.	 xx2000002058

Continues on next page

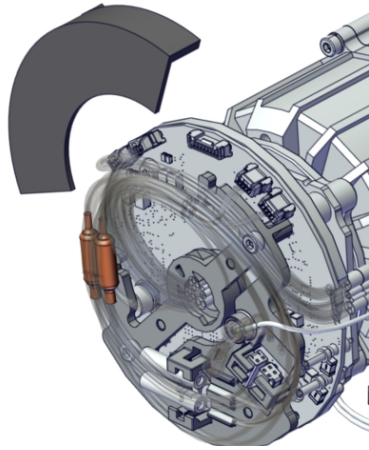
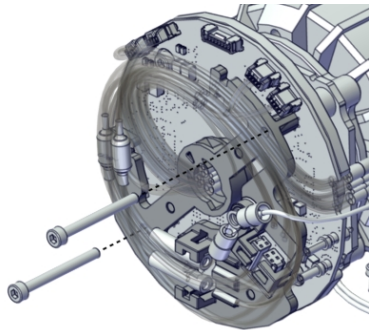
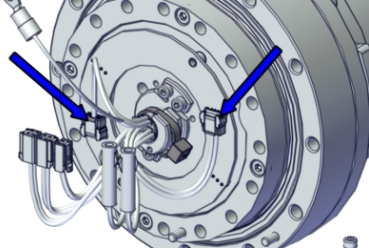
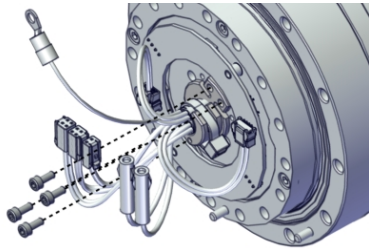
	Action	Note
4	Remove the protection plate.	 <p>xx2100000301</p>
5	Remove the cable support from the drive board by removing the attachment screws.	 <p>xx2000002055</p>
6	Disconnect the two connectors from the torque sensor board. <ul style="list-style-type: none"> • TQ.A • TQ.B 	 <p>xx2000002053</p>
7	Remove the cable plate by removing the attachment screws.	 <p>xx2000002049</p>

Continues on next page

5 Repair

5.3.7 Replacing the axis-6 cabling

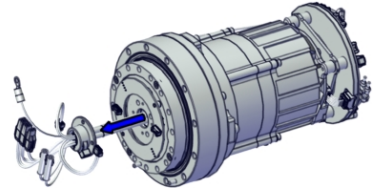

Continued

	Action	Note
8	<p>Remove the joint cable from the hollow shaft from the torque sensor side.</p> <p> CAUTION</p> <p>The connectors and the joint unit cables are sensitive to mechanical damage. Handle the assembly with care.</p>	 <p>xx2000002060</p>

Refitting the joint cabling

Use these procedures to refit the joint-6 cabling.

Refitting the joint cable

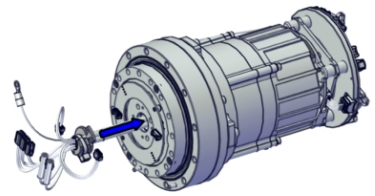
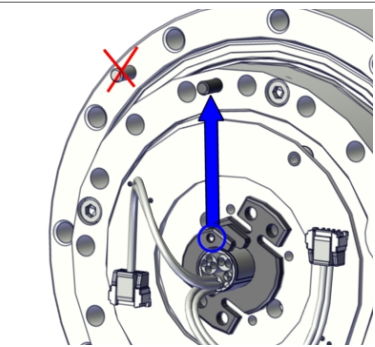
	Action	Note
1	<p> ELECTROSTATIC DISCHARGE (ESD)</p> <p>The unit is sensitive to ESD. Before handling the unit read the safety information in section The unit is sensitive to ESD on page 53.</p>	
2	<p>Place the joint cable through the hollow shaft from the torque sensor side.</p> <p> CAUTION</p> <p>The connectors and the joint unit cables are sensitive to mechanical damage. Handle the assembly with care.</p>	 <p>xx2000002048</p>
3	<p>Orient the cable plate according to the figure. The circle on the cable plate should point towards the guide pin on the torque sensor.</p>	 <p>xx2000002051</p>

Continues on next page

5.3.7 Replacing the axis-6 cabling
Continued

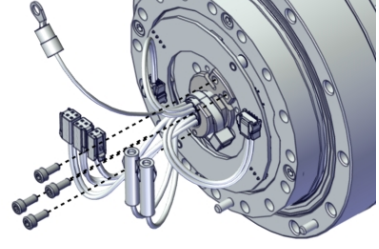
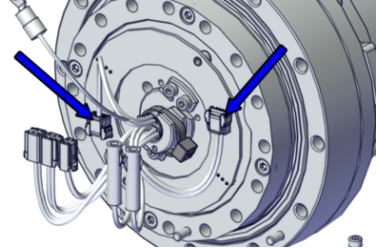
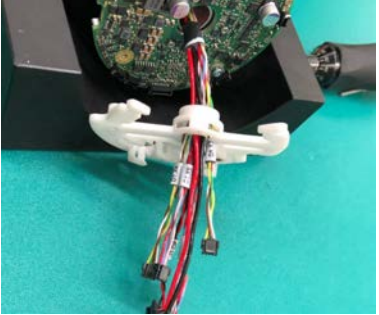
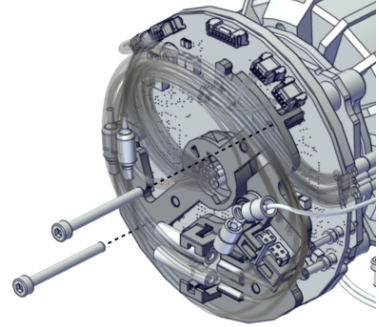
	Action	Note
4	Secure the cable plate to the joint unit with the attachment screws.	<p>Hex socket head cap screw: M2.5x6 12.9 Lafre 2C2B/FC6.9 (4 pcs) Tightening torque: 0.45 Nm.</p>  <p>xx2000002049</p>
5	<p>Connect the two connectors to the torque sensor board.</p> <ul style="list-style-type: none"> • TQ.A to CH1/A • TQ.B to CH2/B 	 <p>xx2000002053</p>
6	Insert the cabling through the cable support and fit the support to the drive board with the attachment screws.	 <p>xx2000002056</p> <p>Hex socket head cap screw: M3x30 12.9 Lafre 2C2B/FC6.9 (2 pcs) Tightening torque: 0.45 Nm.</p>  <p>xx2000002055</p>

Continues on next page



5 Repair

5.3.7 Replacing the axis-6 cabling

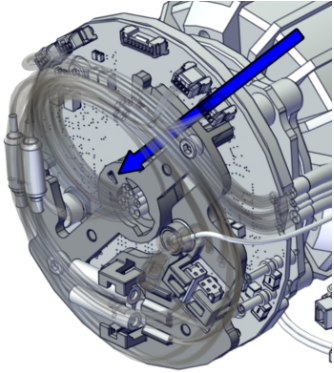
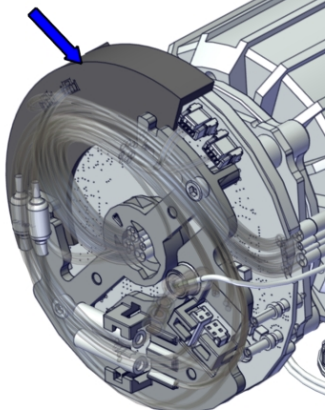
Continued

	Action	Note
7	Keep the cabling loose, making sure not to twist or strain it. Use the cable tie to pre-fix the cable by hand.	 xx2100000507
8	Fit the protection plate to the drive board unit.	Protection plate: 3HAC077790-001 (for CRB 15000-5/0.95) / 3HAC087789-001 (for CRB 15000-10/1.52 and CRB 15000-12/1.27)  xx2000002057

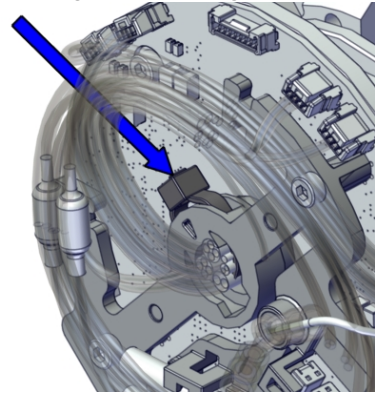
Continues on next page

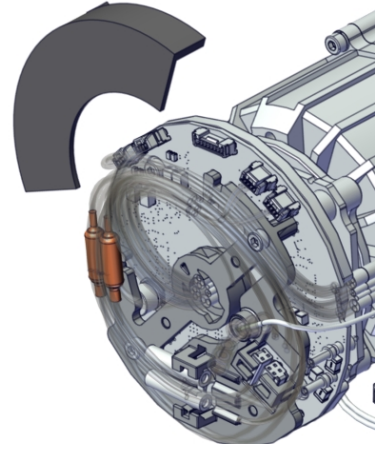
	Action	Note
9	<p>Secure the cables to the cable support with a cable tie, using a cable tie gun.</p> <p>Assembly direction for the cable tie is shown in the figure.</p>	<p>Cable tie: 3HAC075545-001. For securing joint unit cable.</p> <p>Cable tie gun EVO 7i</p> <p>Setting for cable tie gun: 6.75.</p>  <p>xx2000002058</p>  <p>xx2000002059</p>
10	<p>Remove the protection plate.</p>	 <p>xx2100000301</p>



Continues on next page

5 Repair

5.3.7 Replacing the axis-6 cabling

Continued

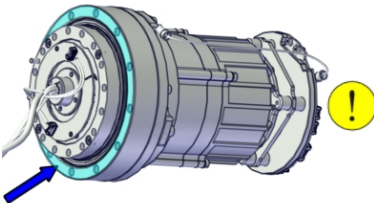

Preparations before fitting the joint unit (-5/0.95)

	Action	Note
1	 ELECTROSTATIC DISCHARGE (ESD) The unit is sensitive to ESD. Before handling the unit read the safety information in section <i>The unit is sensitive to ESD on page 53.</i>	
2	Clean the mounting surface of the joint unit and the mating surface on the casting with isopropanol. Joint unit mounting surface is pointed out in the figure.	Cleaning agent: Isopropanol Flange sealant: Loctite 574
3	Apply a thin layer of flange sealant to the mounting surface. Do not contaminate the radial sealing with sealant.  CAUTION The connectors and the joint unit cables are sensitive to mechanical damage. Handle the assembly with care.  ELECTROSTATIC DISCHARGE (ESD) The unit is sensitive to ESD. Before handling the unit read the safety information in section <i>The unit is sensitive to ESD on page 53.</i>	 xx2000001860

Refitting the axis-6 joint unit

	Action	Note
1	 CAUTION Axis-6 joint unit used for CRB 15000-5/0.95 has the same appearance as that used for CRB 15000-10/1.52 and CRB 15000-12/1.27. Do not mix the joint units for different manipulator variants. Always check the mark or label on the joint units before refitting.	

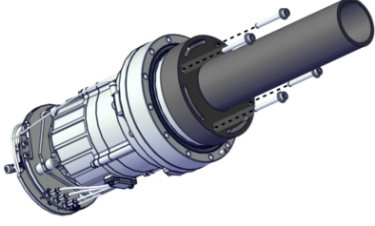
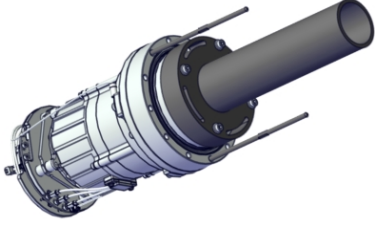
Continues on next page

	Action	Note
2	<p>Fit the lifting aid to the joint unit.</p> <p> CAUTION</p> <p>The connectors and the joint unit cables are sensitive to mechanical damage. Handle the assembly with care.</p>	<p>Joint unit: 3HAC079143-001 (for CRB 15000-5/0.95) / 3HAC087546-001 (for CRB 15000-10/1.52 and CRB 15000-12/1.27)</p> <p>Lifting aid: 3HAC077789-001</p> <p>Screws: M3x12 (4 pcs)</p>  <p>xx2000001957</p>
3	<p>Fit two guide pins to the joint unit.</p>	<p>Guide pin, M3x110: 3HAC077787-001</p> <p>Always use guide pins in pairs.</p> <p>For joint units on axes 4, 5 and 6.</p>  <p>xx2000002438</p>
4	<p>Place the cabling at the slot before refitting the joint unit.</p>	 <p>xx2100000041</p>

Continues on next page

5 Repair

5.3.7 Replacing the axis-6 cabling

Continued

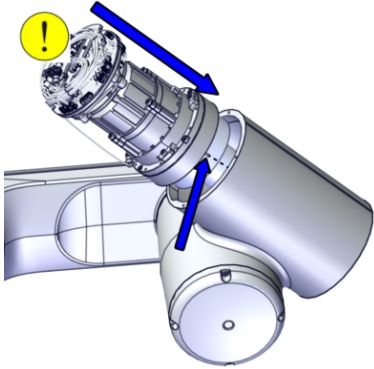
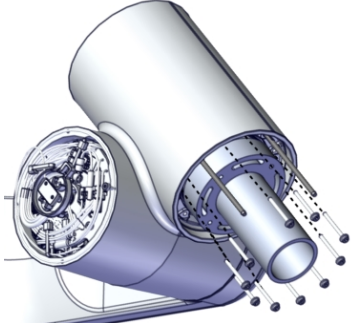
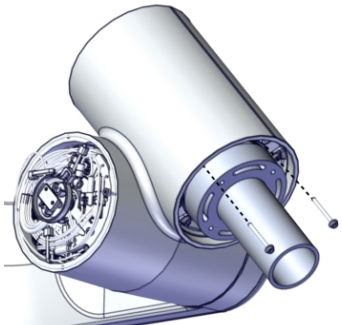
	Action	Note
5	<p>Fit the joint unit to the tilt, aligning the pin with the pin hole.</p> <p> CAUTION</p> <p>The connectors and the joint unit cables are sensitive to mechanical damage. Handle the assembly with care.</p>	 <p>xx2000002195</p>
6	<p>Secure the joint unit with new attachment screws.</p>	<p>Flange socket head screw with glue: 3HAB3413-330 M3x30 12.9 Lafre 2C2B/FC6.9+PrO-COat111, with NYPLAS glue , 12 pcs Used for joint unit of CRB 15000-5/0.95.</p> <p>Always use new screws when refitting a joint unit. If ordering a new joint unit spare part, new screws are included.</p>  <p>xx2100000329</p>
7	<p>Remove the guide pins and secure the remaining two attachment screws.</p>	 <p>xx2000002170</p>
8	<p>Pre-tighten the screws crosswise.</p>	
9	<p>Torque tighten all screws crosswise.</p>	<p>Tightening torque: 1.4 Nm (for CRB 15000-5/0.95) / 1.9 Nm (for CRB 15000-10/1.52 and CRB 15000-12/1.27)</p>

Continues on next page

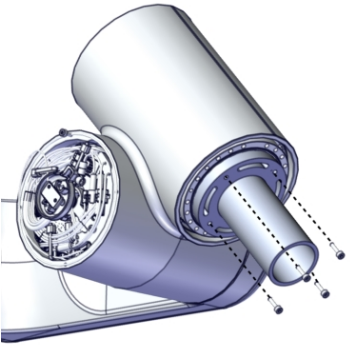
	Action	Note
10	Remove the lifting aid by removing the screws.	 <p>xx2000002168</p>
11	Clean pushed-out flange sealant, if any.	

Connecting the axis-6 joint unit cabling

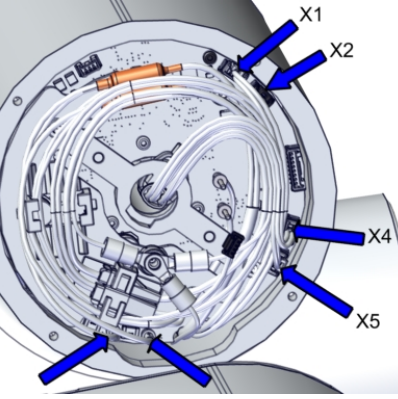
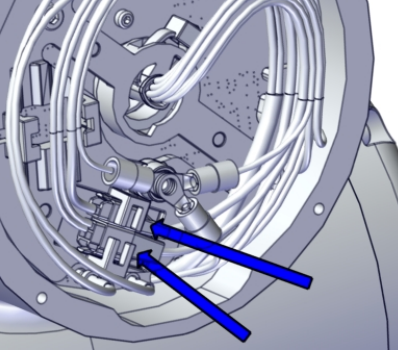
	Action	Note
1	Reconnect the connectors to the drive board. <ul style="list-style-type: none"> • D6.X1 to X1 • D6.DC+ to +DC • D6.DC- to Ground • D6.X4 to X4 • D6.X2 to X2 • D6.X5 to X5 	 <p>xx2000002164</p>
2	Connect the connectors to each other and snap them to the cable holders. <ul style="list-style-type: none"> • J7.CS to J7.CS • J7.CP to J7.CP 	 <p>xx2000002163</p>

Continues on next page

5 Repair

5.3.7 Replacing the axis-6 cabling

Continued

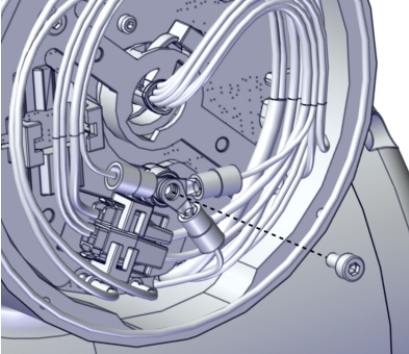
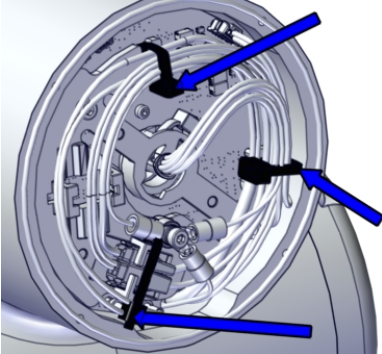
	Action	Note
3	Secure the cables for functional earth and protective earth with a screw.	<p>Hex socket head cap screw: M3x6 (1 pcs).</p> <p>Tightening torque: 0.8 Nm.</p>  <p>xx2000002162</p>
4	Secure the cabling with cable ties.	<p>Cable ties (3 pcs)</p>  <p>xx2000002161</p>

Refitting the arm-side interface

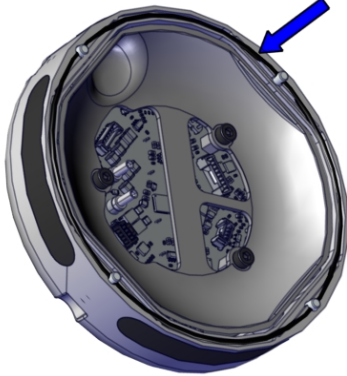
	Action	Note
1	Fit the o-ring to its groove. Replace if damaged.	<p>O-ring: 3HAC061327-051</p>  <p>xx2000002551</p>

Continues on next page

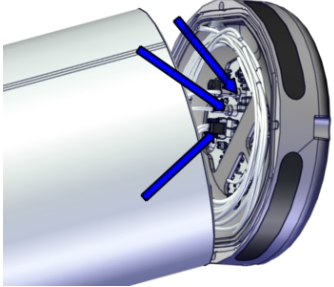
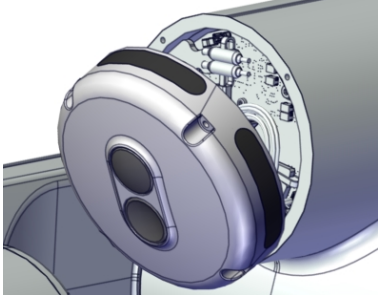
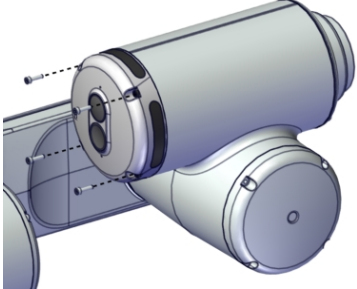
	Action	Note
2	<p>Place the arm-side interface at mounting position and reconnect the connectors.</p> <ul style="list-style-type: none"> • ASI.DC+ • ASI.DC- • ASI.X1 <p>The correct orientation of the arm-side interface is with the convex button in upper position.</p> <p> Note</p> <p>Do not leave the arm-side interface in location without being secured with the attachment screws.</p>	 <p>xx2100000335</p>  <p>xx2100000336</p>
3	<p>Refit the arm-side interface with four screws.</p>	<p>Valid for CRB 15000-5/0.95 Hex socket head cap screw: M3x30 12.9 Lafre 2C2B/FC6.9 (4 pcs) Tightening torque: 0.45 Nm</p> <p>Valid for CRB 15000-10/1.52 and CRB 15000-12/1.27 Hex socket head cap screw: M3x20 12.9 Lafre 2C2B/FC6.9 (4 pcs) Tightening torque: 0.45 Nm</p>  <p>xx2000002550</p>

Continues on next page

5 Repair

5.3.7 Replacing the axis-6 cabling

Continued

Refitting the tool flange adapter

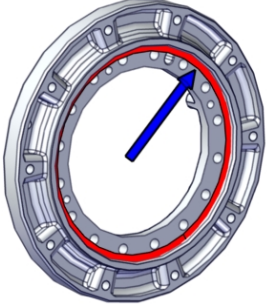
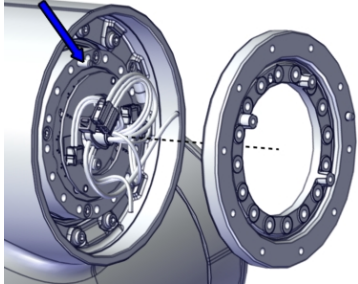
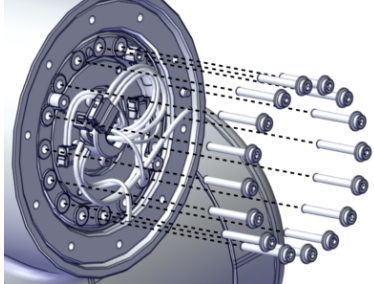
	Action	Note
1	Clean the mounting surface with isopropanol. Apply flange sealant to the corner of the adapter mounting surface, as pointed out in the figure.	Cleaning agent: Isopropanol Flange sealant: Loctite 574  xx2000002196
2	Refit the tool flange adapter, aligning the pin with the pin hole.	Axis-6 inner flange: 3HAC073952-001  xx2000002167
3	Secure with screws.	Flange socket head screw: M3x20 12.9 Lafre 2C2B/FC6.9+PrO-COat111 (16 pcs) Tightening torque: 1.8 Nm.  xx2000002165

Continues on next page

Connecting the tool flange functional earth cable

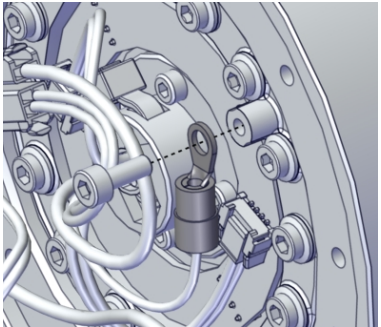
	Action	Note
1	Secure the cable for functional earth to the tool flange adapter with a screw.	 <p>xx2000002159</p>

Refitting the tool flange

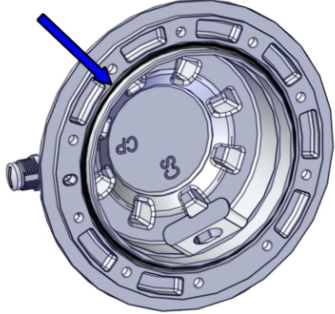
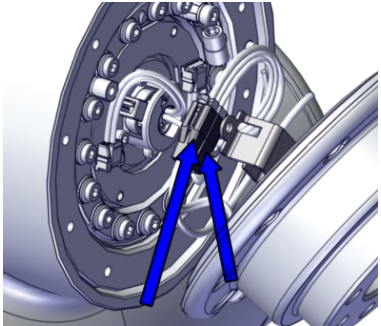
	Action	Note
1	Check the o-ring on the tool flange and lubricate with grease. Replace if damaged.	<p>Axis-6 flange: 3HAC073953-001 O-ring: 3HAB3772-182 Grease: 3HAC042536-001 (Shell Gadus S2)</p>  <p>xx2000002197</p>
2	Place the tool flange at mounting position and reconnect the CP/CS connectors.	 <p>xx2000002158</p>

Continues on next page

5 Repair

5.3.7 Replacing the axis-6 cabling

Continued

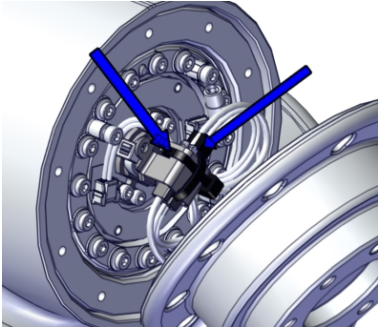
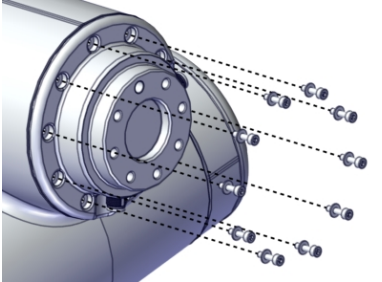
	Action	Note
3	Fit the connectors to the cable bracket and secure the connectors with two cable ties.	<p>Cable ties (2 pcs)</p>  <p>xx2000002157</p>
4	Refit and secure the tool flange with screws and washers.	<p>Hex socket head cap screw: M3x12 12.9 Lafre 2C2B/FC6.9 (10 pcs) Spring washer: 7x3.2x0.6 Steel (10 pcs) Tightening torque: 1.8 Nm.</p>  <p>xx2000002155</p>

Continues on next page

Concluding procedure

	Action	Note
1	<p>Calibrate the joint unit torque sensor.</p> <ol style="list-style-type: none"> 1 On the FlexPendant, go to the Code app and call the calibration procedure using PP to Routine, not by using Call Routine. 2 Select the Joint Unit Replacement feature and then select the axis to calibrate. 3 The controller is now restarted. Once the home screen of the FlexPendant is shown, press the Play button to continue the calibration routine. 4 The robot moves to a position or positions where measurements are performed. 5 The results of the measurements are presented together with the current values in the controller. Choose whether to save the calibration data or not. 6 If new calibration data is saved you will be asked to do a test with the lead-through functionality active to verify that the sensors work correctly. 7 Finally the robot is moved back to the original position. 8 Test the brake release (movement without drive power) functionality, see Testing the brake release functionality on page 196. 	See Calibration on page 1063
2	 <p>DANGER</p> <p>Make sure all safety requirements are met when performing the first test run. See Test run after installation, maintenance, or repair on page 90.</p>	

5 Repair

5.3.8 Replacing the axis-5 to axis-6 transition cabling

5.3.8 Replacing the axis-5 to axis-6 transition cabling

Location of the cable harness

The cable harness is located as shown in the figure.

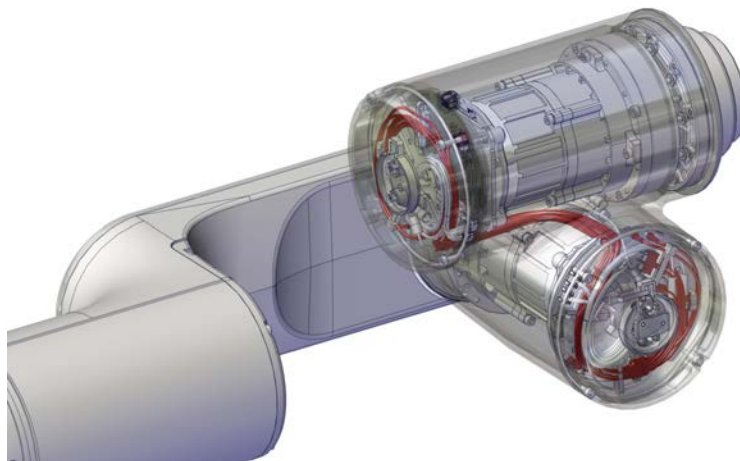

xx210000091

Summary of the replacement procedure

This is a brief summary of the replacement procedure, containing the major actions to be performed.

- 1 Remove the tubular cover.
- 2 Separate the cabling between the tubular and the tilt (at the axis-4 joint unit).
- 3 Remove the tilt and place on a workbench.
- 4 Remove the axis-6 joint unit.
- 5 Remove the axis-5 cover.
- 6 Remove the axis-5 joint unit. Move the cabling from old to new joint unit.
- 7 Replace the axis-5 to axis-6 transition cabling.

Replacing the axis-5 to axis-6 transition cabling

The replacement procedure is identical to replacing the axis-5 joint unit.

Follow procedure [Replacing the axis-5 joint unit and the axis-5 to axis-6 transition cabling on page 992](#).

5.3.9 Replacing the brake release unit

Location of the brake release unit



CAUTION

Brake release units exist only on robots with RobotWare earlier than 7.10. On robots with RobotWare 7.10 or later, brake release units are unavailable.

The brake release units are located as shown in the figure.

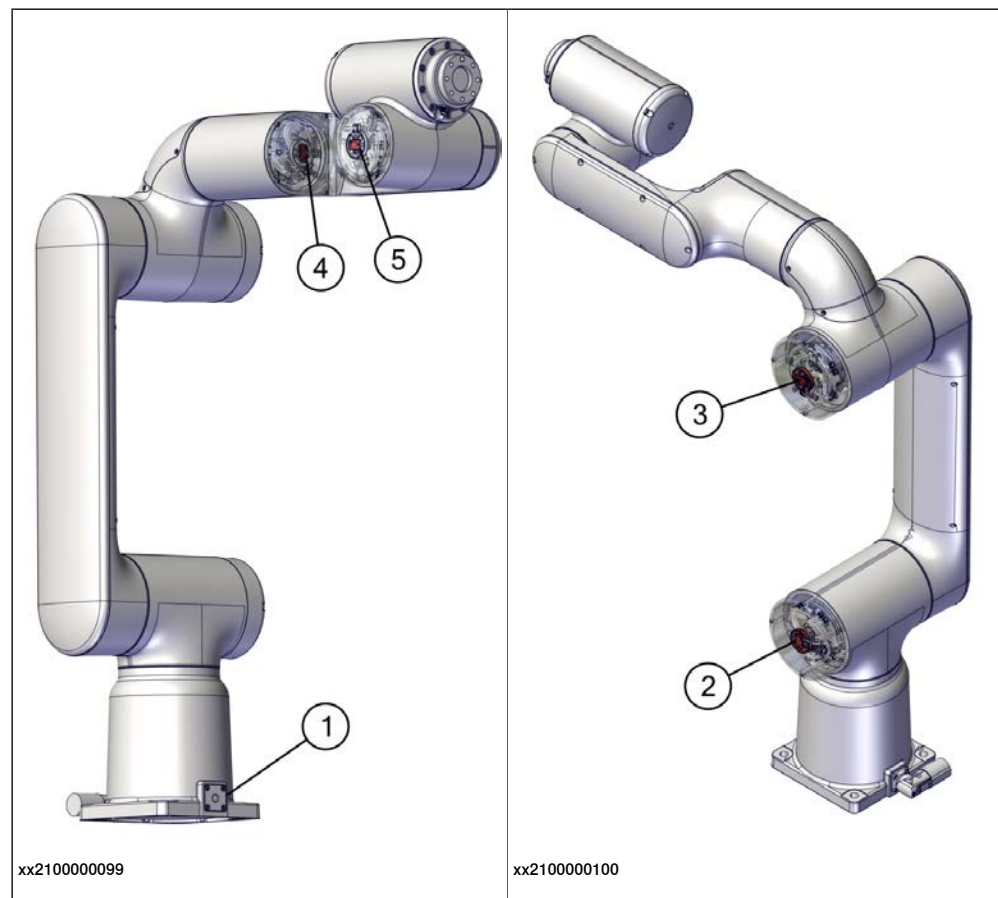

Summary of the replacement procedure

This is a brief summary of the replacement procedure, containing the major actions to be performed.

Axis-1 brake release unit

- 1 Jog the robot to transportation position.
- 2 Loosen the robot from the foundation and lay it down on its back.
This step requires two persons.
- 3 Remove the base cover.
- 4 Replace the brake release unit.

Axis-2/-3/-4/-5 brake release unit

- 1 Open the joint unit cover.

Continues on next page

5 Repair



5.3.9 Replacing the brake release unit

Continued

- 2 Replace the brake release unit.

Required spare parts

 **Note**
The spare parts related to the brake release function using the external tool are discontinued from Q2 2023.

Spare part	Article number	Note
Brake release unit	3HAC079144-001	Axis 1  Note The spare parts related to the brake release function using the external tool are discontinued from Q2 2023.
Brake release unit	3HAC079145-001	Axes 2, 3, 4 and 5  Note The spare parts related to the brake release function using the external tool are discontinued from Q2 2023.

Required tools and equipment

Equipment	Article number	Note
Standard toolkit	-	Content is defined in section Standard toolkit on page 1099 .

Required consumables

 **Note**
The spare parts related to the brake release function using the external tool are discontinued from Q2 2023.

Consumable	Article number	Note
Cable ties	-	
O-ring	3HAB3772-119	Axis-1 brake release unit Replace if damaged.
O-ring	3HAB3772-64	Base cover, used for CRB 15000-5/0.95.
O-ring	3HAC061327-047	Cover for axis 2/3, used for CRB 15000-5/0.95. Replace if damaged.



Continues on next page

Consumable	Article number	Note
O-ring	3HAC061327-051	Axis-4 cover, used for CRB 15000-5/0.95. Replace if damaged.
O-ring	3HAC061327-051	Axis-5 cover, used for CRB 15000-5/0.95. Replace if damaged.
Grease	3HAC031695-001	Harmonic Grease 4B No.2 Used to lubricate the seals.
Grease	3HAC042536-001	Shell Gadus S2

Replacing the brake release unit for axis 1

Use these procedures to replace the brake release unit.

Preparations before removing the brake release unit

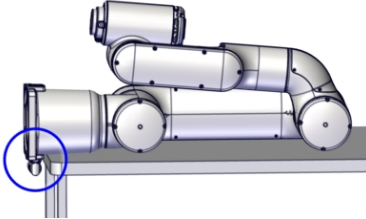
	Action	Note
1	Jog the robot to the specified position: <ul style="list-style-type: none"> • Axis 1: 0° • Axis 2: 0° • Axis 3: +85° • Axis 4: 0° • Axis 5: 0° • Axis 6: 0° 	 <p>xx2100000113</p>
2	 CAUTION Turn off all supplies for electrical power to the robot, before starting the repair work.	
3	Prepare a working bench where the robot can be laid down on its back with the base socket outside the table edge.	 <p>xx2100000414</p>



Continues on next page

5 Repair

5.3.9 Replacing the brake release unit

Continued

Laying down the robot (-5/0.95)

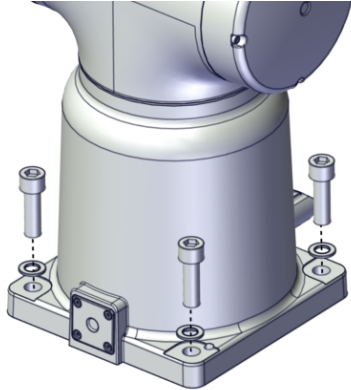
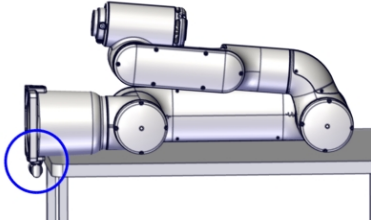
	Action	Note
1	 CAUTION The CRB 15000 robot weighs 28 kg. A minimum of two persons are required for lifting as well as securing the robot in order to avoid any damage, instability, and injury.	
2	<p>Loosen the robot from the foundation.</p> <ul style="list-style-type: none">• Person 1: keep holding the robot stable.• Person 2: loosen the robot base from the foundation by removing the attachment screws and washers.• Both persons: grasp the robot at appropriate locations and lay it down on its back on a working bench. Do not damage the base socket.  CAUTION Do not leave the robot standing unfastened to the foundation, it is not stable on its own.	 xx2100000415  xx2100000414

Continues on next page

Removing the base cover

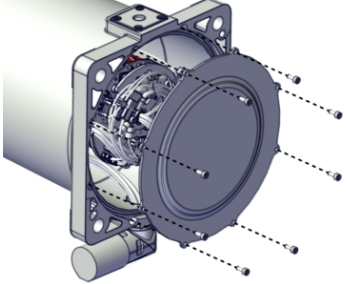
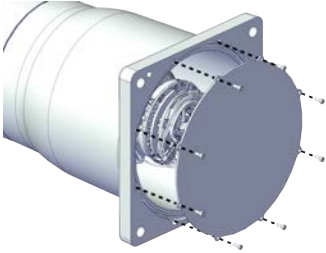
	Action	Note
1	Remove the bottom cover by removing the attachment screws.	<p>Valid for CRB 15000-5/0.95</p>  <p>xx2000002007</p> <p>Valid for CRB 15000-10/1.52 and CRB 15000-12/1.27</p>  <p>xx2300000760</p>

Removing the brake release unit

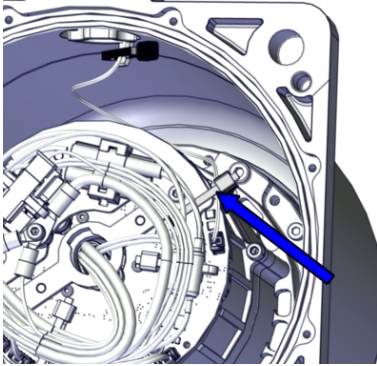
	Action	Note
1	Cut the cable tie.	 <p>xx2100000410</p>

Continues on next page

5 Repair

5.3.9 Replacing the brake release unit

Continued

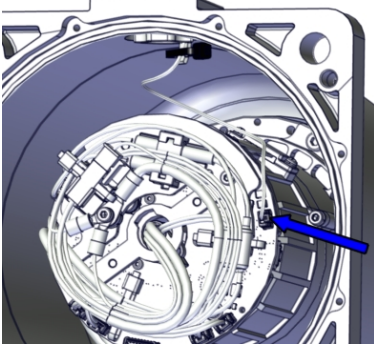
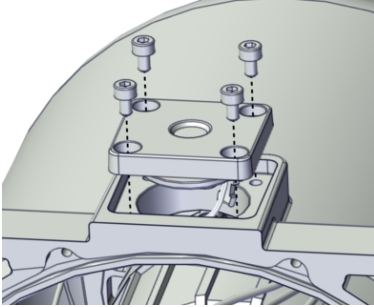
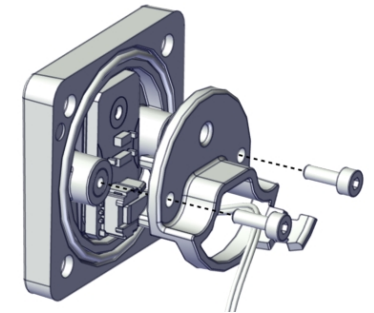
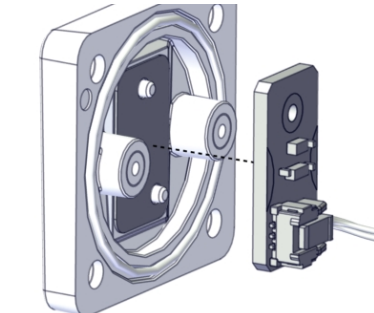
	Action	Note
2	Disconnect the brake release cable from the board.	 xx210000411
3	Remove the brake release unit by removing the screws.	 xx210000413
4	Remove the brake release cover by removing the two screws.	 xx210000416
5	Remove the brake release board.	 xx210000418

Continues on next page

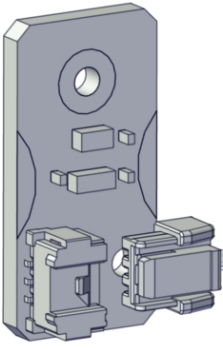
	Action	Note
6	Disconnect the brake release cable from the board.	 <p>xx210000417</p>

Refitting the brake release unit

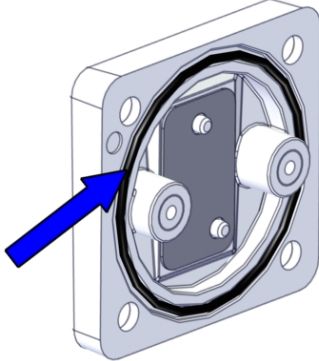
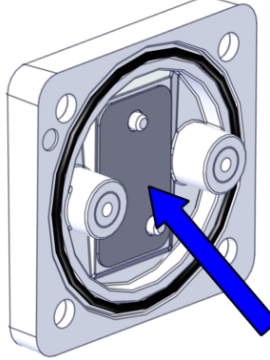
	Action	Note
1	Wipe, lubricate and fit the o-ring to its groove. Replace if damaged.	<p>O-ring: 3HAB3772-119 Grease: 3HAC031695-001 Harmonic Grease 4B No.2 Used to lubricate the seals.</p>  <p>xx210000419</p>
2	If not already fitted, place the sheet metal inside the cover.	 <p>xx210000420</p>

Continues on next page

5 Repair

5.3.9 Replacing the brake release unit

Continued

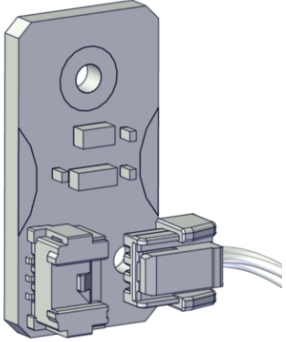
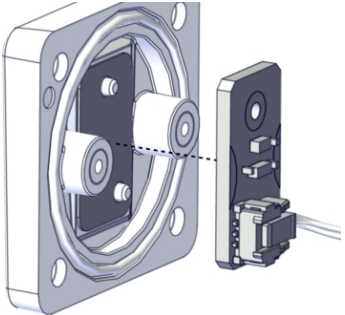
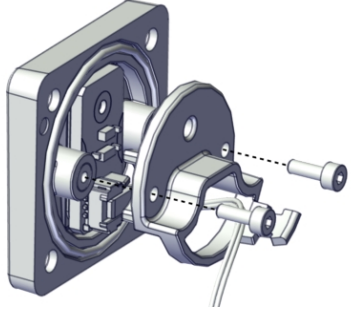
	Action	Note
3	Connect the brake release cable to the board.	<p>Brake release unit: 3HAC079144-001</p>  <p>xx2100000417</p>
4	Fit the brake release board to the sheet metal.	 <p>xx2100000418</p>
5	Fit the brake release cover and secure with two screws.	<p>Screws: M2x6 12.9 Gleitmo 605 (2 pcs) Tightening torque: 0.2 Nm.</p>  <p>xx2100000416</p>

Continues on next page

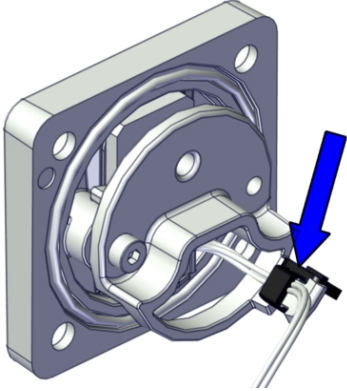
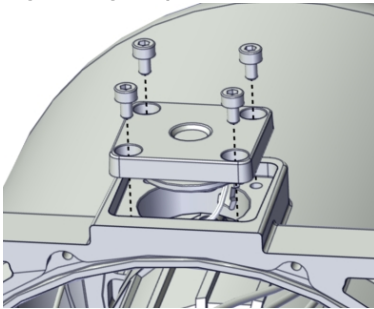
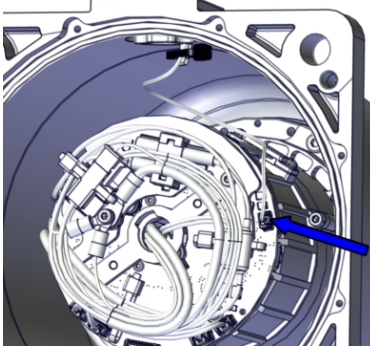
	Action	Note
6	Secure the brake release cable with a cable tie.	 xx2100000421
7	Refit the brake release unit with the screws.	<p>Screws: M3x5 12.9 Lafre 2C2B/FC6.9 (4 pcs) Tightening torque: 0.45 Nm.</p>  xx2100000413
8	Reconnect the brake release connector DR.X8 to the drive board.	 xx2100000411

Continues on next page

5 Repair

5.3.9 Replacing the brake release unit

Continued

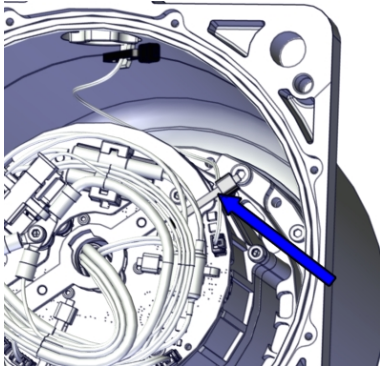
	Action	Note
9	Secure the brake release cable with a cable tie.	 xx2100000410

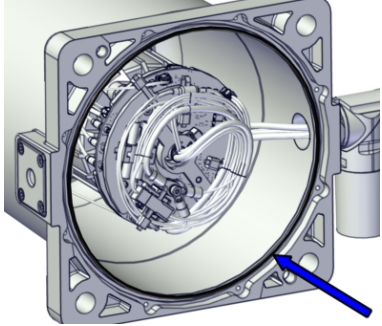

Refitting the base cover (-5/0.95)

	Action	Note
1	Wipe, lubricate and fit the o-ring to its groove. Replace if damaged.	O-ring: 3HAB3772-64 Grease: 3HAC042536-001 (Shell Gadus S2)  xx2000002016

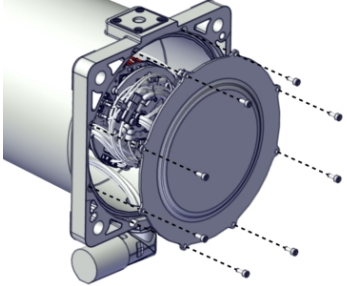
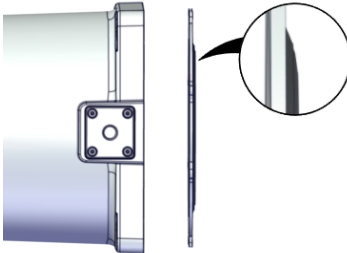
Continues on next page

	Action	Note
2	<p>Refit the bottom cover with the attachment screws.</p> <p> Note</p> <p>For CRB 15000-5/0.95, fit the cover in correct direction, the protrusion of the cover must face outwards.</p>	<p>Hex socket head cap screw: M3x8 12.9 Lafre 2C2B/FC6.9 (8 pcs) Tightening torque: 1.2 Nm.</p>  <p>xx2000002007</p>  <p>xx2100000268</p>

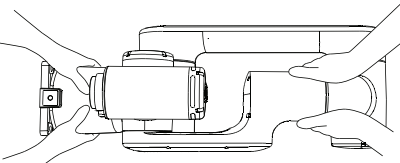
Lifting and securing the robot (-5/0.95)

	Action	Note
1	<p> CAUTION</p> <p>The CRB 15000 robot weighs 28 kg. A minimum of two persons are required for lifting as well as securing the robot in order to avoid any damage, instability, and injury.</p> <p>Special consideration is necessary when mounting the robot in an elevated, suspended or wall mounted position.</p>	
2	<p>Grasp the robot at the foot and elbow, as shown in the figure, and lift it up from the transportation package.</p>	 <p>xx2100000118</p>
3	<p> CAUTION</p> <p>Do not leave the robot standing unfastened to the foundation, it is not stable on its own.</p>	
4	<p>Fit two pins to the holes in the base.</p>	<p>Centering pins: DIN6325, hardened steel Ø6x24 mm, 2 pcs .</p>

Continues on next page

5 Repair

5.3.9 Replacing the brake release unit

Continued

	Action	Note
5	Raise the robot to standing and secure to foundation, paying attention to the centering holes at the bottom of the robot base. <ul style="list-style-type: none"> • Person 1: keep holding the robot stable. • Person 2: secure the robot base to the foundation with the securing screws and washers. 	Screws: M10x35, 4 pcs, quality 8.8 Washers: 23/10.5/2.5 mm Steel
6	Tighten the bolts in a crosswise pattern to ensure that the base is not distorted.	Tightening torque: 32 Nm \pm 10%



Concluding procedure

	Action	Note
1	 DANGER Make sure all safety requirements are met when performing the first test run. See Test run after installation, maintenance, or repair on page 90 .	

Replacing the brake release unit for axes 2, 3, 4 and 5

Use these procedures to replace the brake release unit.

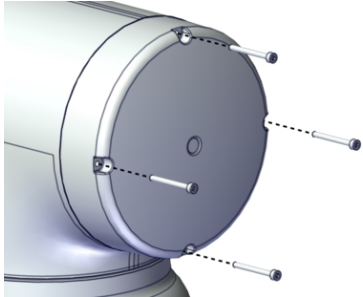
Opening the joint unit cover

	Action	Note
1	 CAUTION Make sure that all supplies for electrical power are turned off.	
2	Remove the cover screws.	 xx2000001935
3	 CAUTION Valid for CRB 15000-5/0.95 There is cabling connected between the cover and the joint unit drive board. Open the cover with care to avoid damage to the cabling or the connector(s). Do not leave the cover in location without being secured with the attachment screws.	

Continues on next page

5.3.9 Replacing the brake release unit

Continued

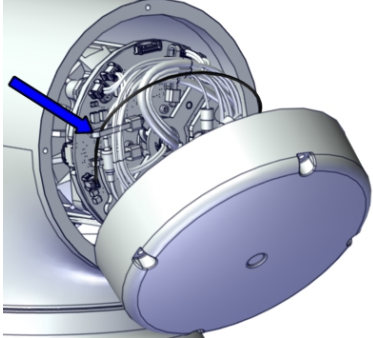
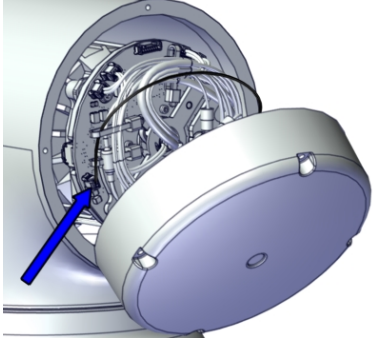
	Action	Note
4	<p>For robots with RobotWare earlier than 7.10 Open the cover and cut the cable tie that holds the brake release cable.</p>	 <p>xx2000001931</p>
5	<p>For robots with RobotWare earlier than 7.10 Disconnect the brake release connector DR.X8 from the drive board. Remove the cover.</p>	 <p>xx2000001932</p>

Removing the brake release unit

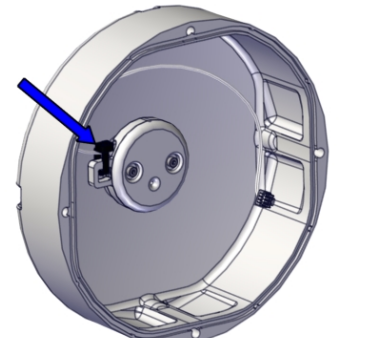
	Action	Note
1	<p>Cut the cable tie.</p>	 <p>xx2100000096</p>

Continues on next page

5 Repair

5.3.9 Replacing the brake release unit

Continued

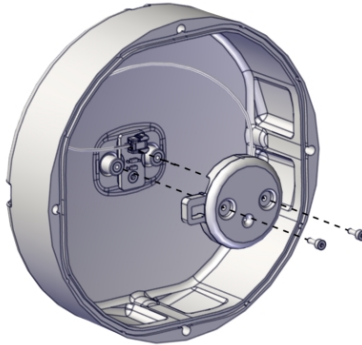
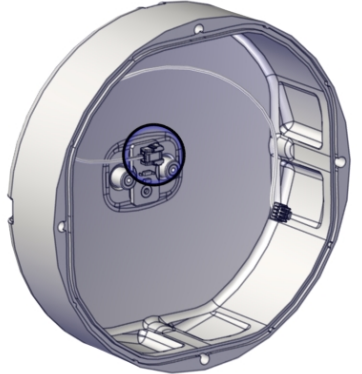
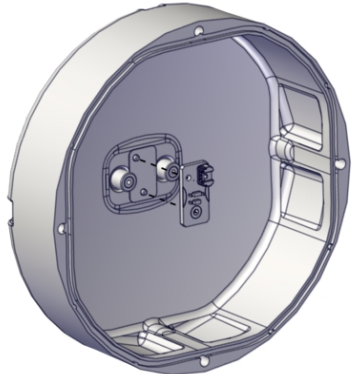
	Action	Note
2	Remove the brake release cover by removing the two screws.	 <p>xx210000095</p>
3	Disconnect the brake release cable from the board.	 <p>xx210000094</p>
4	Remove the brake release board.	 <p>xx210000093</p>

Continues on next page

Refitting the brake release unit

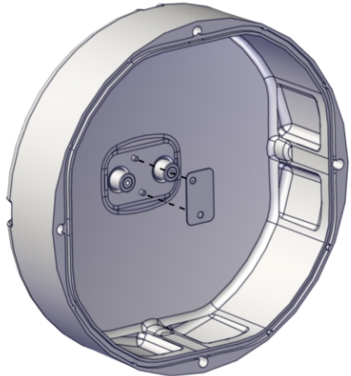
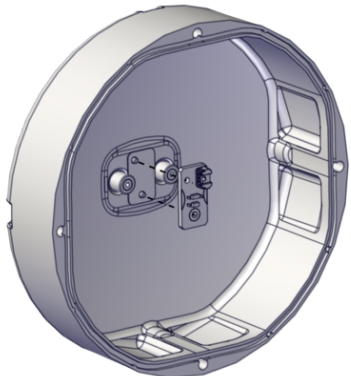
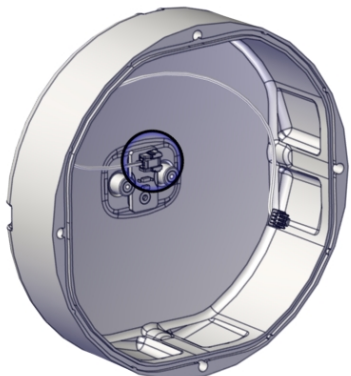
	Action	Note
1	If not already fitted, place the sheet metal inside the cover.	 <p>xx210000092</p>
2	Fit the brake release board to the sheet metal.	 <p>xx210000093</p>
3	Connect the brake release cable to the board.	 <p>xx210000094</p>

Continues on next page

5 Repair

5.3.9 Replacing the brake release unit

Continued

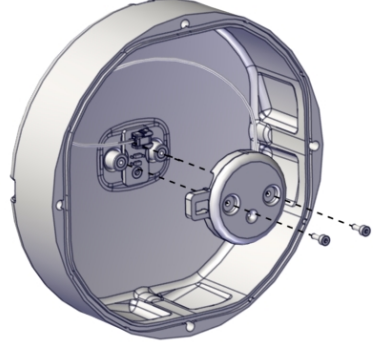
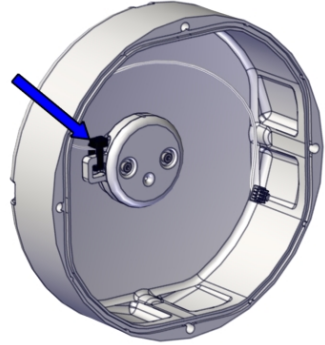
	Action	Note
4	Fit the brake release cover and secure with two screws.	Screws: M2x6 12.9 Gleitmo 605 (2 pcs) Tightening torque: 0.2 Nm.  xx210000095
5	Secure the cable with a cable tie.	 xx210000096

Closing the joint unit cover

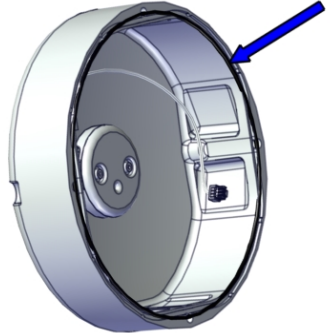
	Action	Note
1	Fit the o-ring to its groove. Replace if damaged.	O-ring: 3HAC061327-047  xx2000001962

Continues on next page

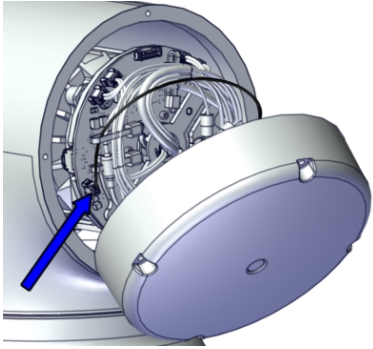
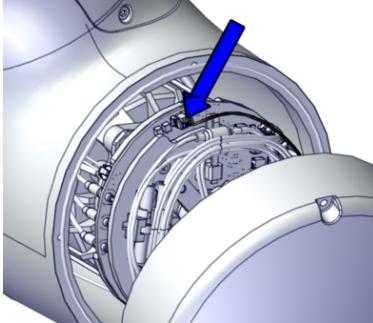
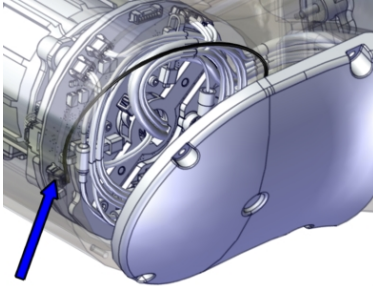
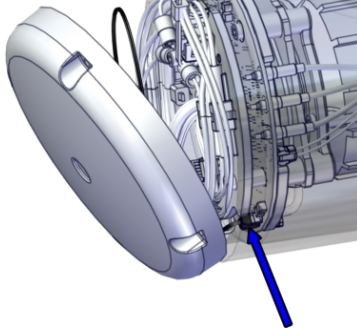
	Action	Note
2	<p>Place the cover at mounting position and reconnect the brake release connector DR.X8 to the drive board.</p> <p>Orient the cover for proper arrangement of the brake release cable.</p>	<p>Axis 2:</p>  <p>xx2000001932</p> <p>Axis 3:</p>  <p>xx2000002023</p> <p>Axis 4: Tweezers</p>  <p>xx2000002085</p> <p>Axis 5:</p>  <p>xx2000002134</p>

Continues on next page

5 Repair

5.3.9 Replacing the brake release unit

Continued

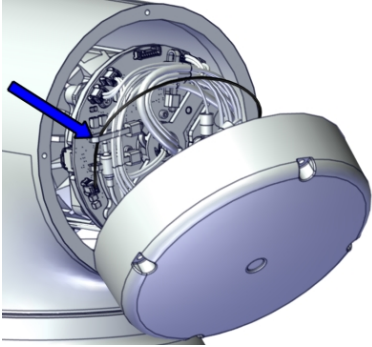
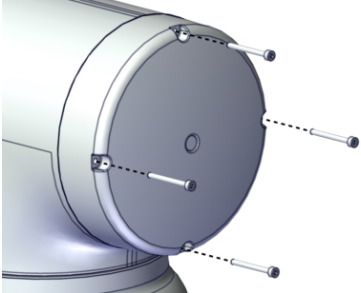
	Action	Note
3	Secure the brake release cable with a cable tie.	<p>Cable ties</p>  <p>xx2000001931</p>
4	Refit the cover with the four screws.	<p>Hex socket head cap screw: M3x30 12.9 Lafre 2C2B/FC6.9 (4 pcs)</p> <p>Tightening torque: Axis 2: 0.45 Nm Axis 3: 0.45 Nm Axis 4: 0.2 Nm Axis 5: 0.2 Nm</p>  <p>xx2000001935</p>

Concluding procedure

	Action	Note
1	 <p>DANGER</p> <p>Make sure all safety requirements are met when performing the first test run. See Test run after installation, maintenance, or repair on page 90.</p>	

5.4 Upper and lower arms

5.4.1 Replacing the lower arm

Location of the lower arm

The lower arm is located as shown in the figure.

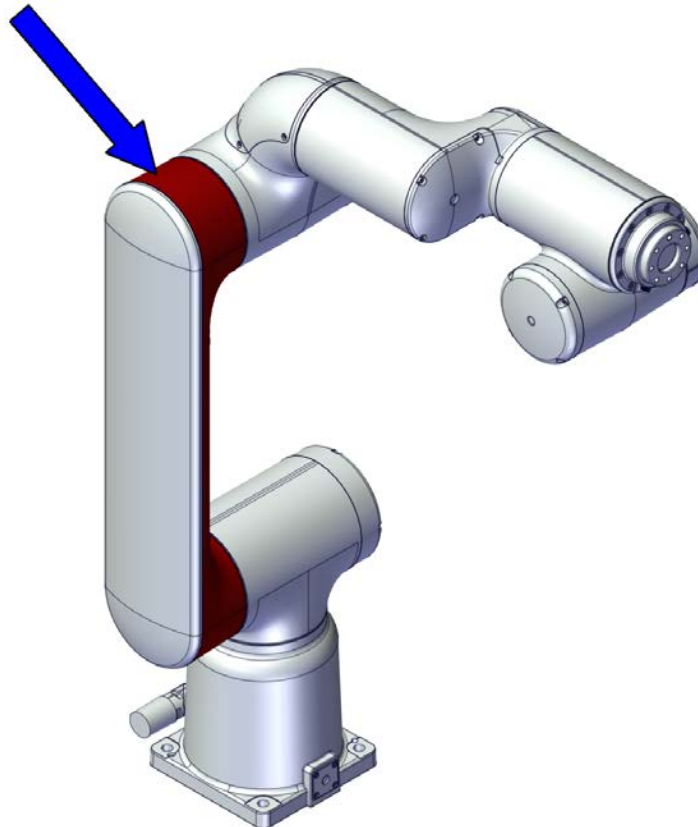

xx2000001928

Summary of the replacement procedure

This is a brief summary of the replacement procedure, containing the major actions to be performed.

- 1 Separate the cabling between the swing and the lower arm.
- 2 Remove the upper arm.
- 3 Replace the lower arm.

Required spare parts



Note

The spare part numbers that are listed in the table can be out of date. See the latest spare parts of the CRB 15000 via myABB Business Portal, www.abb.com/myABB.

Continues on next page

5 Repair

5.4.1 Replacing the lower arm

Continued

Spare part	Article number	Note
Lower arm	3HAC073948-001	Used for CRB 15000-5/0.95.
Lower arm	3HAC081051-001	Used for CRB 15000-10/1.52 and CRB 15000-12/1.27.

Required tools and equipment

Equipment	Article number	Note
Guide pin, M4x120	3HAC077786-001	Always use guide pins in pairs. For joint units on axes 1, 2 and 3 of CRB 15000-5/0.95 and axis 3 of CRB 15000-10/1.52 and CRB 15000-12/1.27.
Guide pin, M5x125	3HAC087786-001	Always use guide pins in pairs. For joint units on axes 1 and 2 of CRB 15000-10/1.52 and CRB 15000-12/1.27.
Standard toolkit	-	Content is defined in section Standard toolkit on page 1099 .

Required consumables

Consumable	Article number	Note
Grease	3HAC042536-001	Shell Gadus S2
Cleaning agent	-	Isopropanol
Flange sealant	-	Loctite 574
Cable ties	-	
O-ring	3HAC061327-044	Lower arm, inner cover of CRB 15000-5/0.95. 1 pcs / cover. Replace if damaged.
O-ring	3HAC061327-075	Lower arm, lower inner cover of CRB 15000-10/1.52 and CRB 15000-12/1.27. Replace if damaged.
O-ring	3HAC061327-044	Lower arm, upper inner cover of CRB 15000-10/1.52 and CRB 15000-12/1.27. Replace if damaged.

Removing the lower arm

Use these procedures to remove the lower arm.

Preparations before removing the lower arm

	Action	Note
1	Jog the robot to the synchronization position.	
2	 CAUTION Turn off all supplies for electrical power to the robot, before starting the repair work.	

Continues on next page

Removing the lower arm covers (-5/0.95)

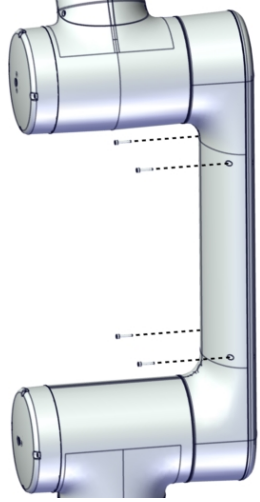
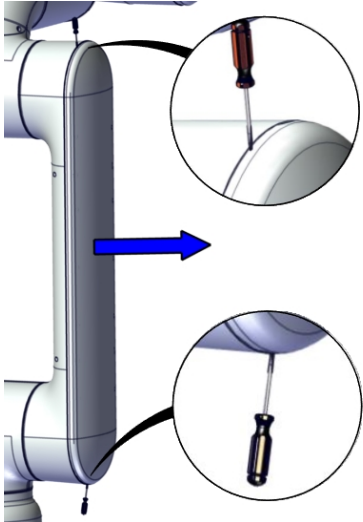
	Action	Note
1	 CAUTION Make sure that all supplies for electrical power are turned off.	
2	Remove the four lower arm cover screws.	 <p>xx2000001929</p>
3	Remove the cover by inserting a small flat screwdriver to snap open the locks at each end of the cover.	 <p>xx2100000267</p>

Continues on next page

5 Repair

5.4.1 Replacing the lower arm

Continued

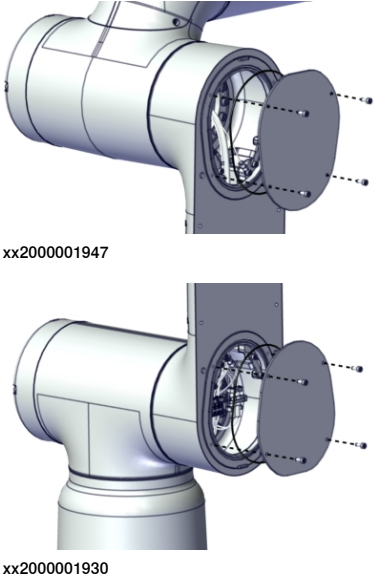
	Action	Note
4	Remove the inner covers by removing the screws.	 <p>xx2000001947</p> <p>xx2000001930</p>

Removing the lower arm covers (-10/1.52 and -12/1.27)

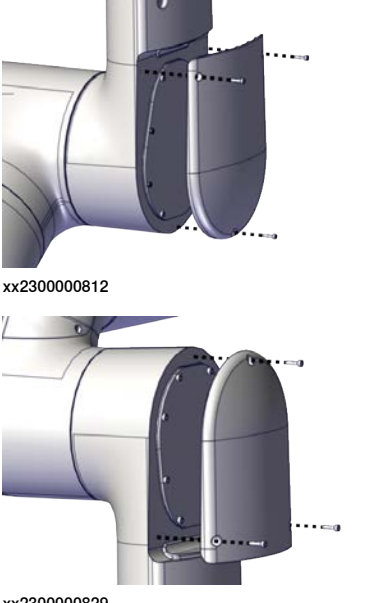
	Action	Note
1	 CAUTION Make sure that all supplies for electrical power are turned off.	
2	Remove the lower arm covers by removing the screws.	 <p>xx2300000812</p> <p>xx2300000829</p>

Continues on next page

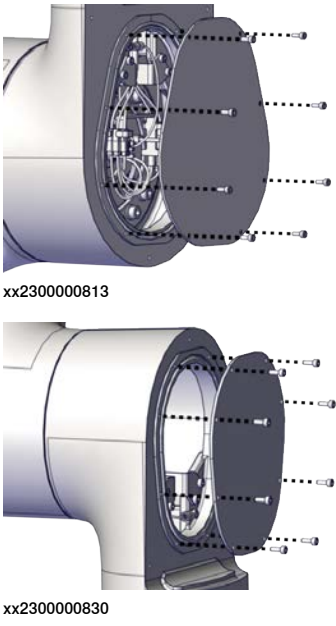
	Action	Note
3	Remove the inner covers by removing the screws.	

Disconnecting the cabling between the lower arm and the swing

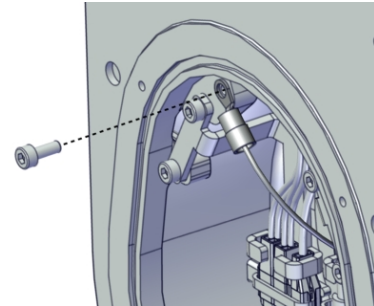
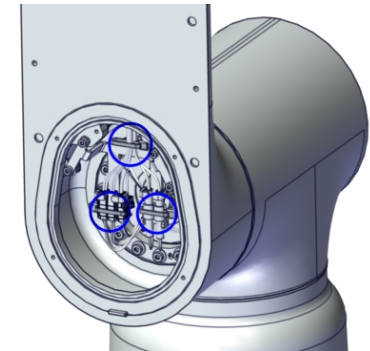
	Action	Note
1	Remove the functional earth cable by removing the screw.	
2	Cut the cable ties.	

Continues on next page

5 Repair

5.4.1 Replacing the lower arm

Continued

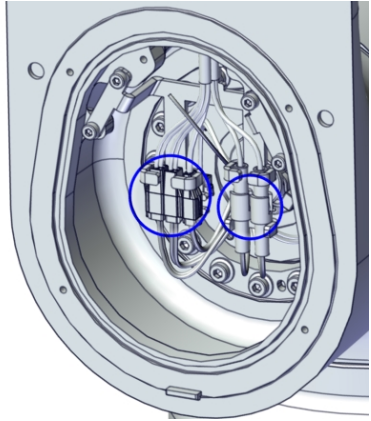
	Action	Note
3	Snap loose and disconnect all connectors.	 xx2000001938

Loosening the cabling between the lower and upper arm

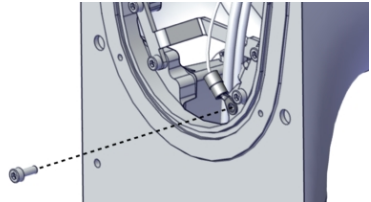
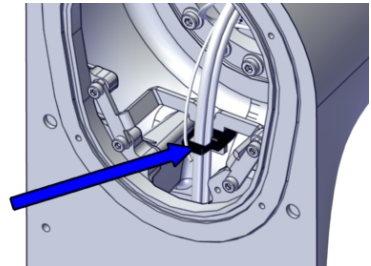
	Action	Note
1	Remove the functional earth cable by removing the screw.	 xx2000001964
2	Cut the cable tie.	 xx2000001965

Removing the upper arm

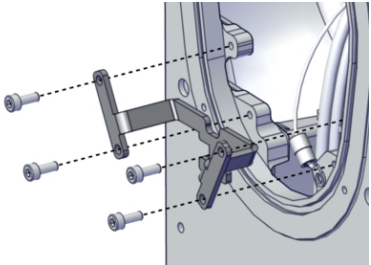
	Action	Note
1	Remove the cable bracket by removing the four screws.	 xx2000001966

Continues on next page

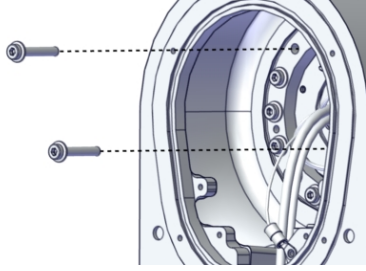
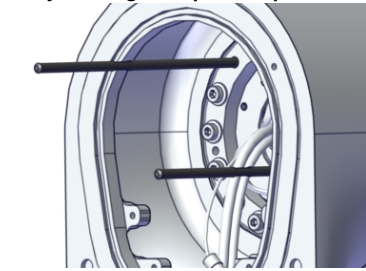
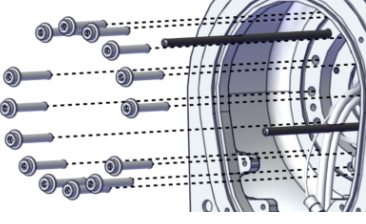
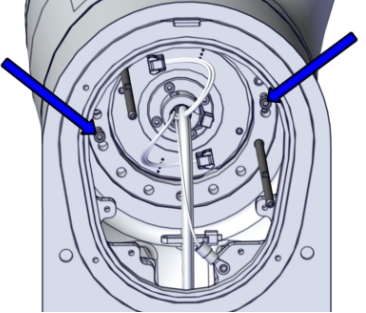
	Action	Note
2	Secure the weight of the upper arm.  CAUTION The weight of the complete upper arm is 14 kg.	
3	Remove two attachment screws.	 xx2000001967
4	Fit two guide pins to the axis-3 joint unit.	Guide pin, M4x120: 3HAC077786-001 Always use guide pins in pairs.  xx2000001968
5	Remove the remaining attachment screws.	 xx2000001969
6	Press the upper arm out of position by using two fully threaded attachment screws as removal tools.	 xx2100000001

Continues on next page

5 Repair

5.4.1 Replacing the lower arm

Continued

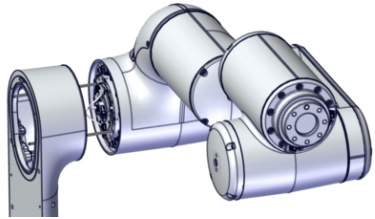
	Action	Note
7	Remove the upper arm from the lower arm. Assist the cabling to be removed from the lower arm while lifting away the complete upper arm. Place the upper arm on a workbench.	 xx2000001970

Removing the lower arm

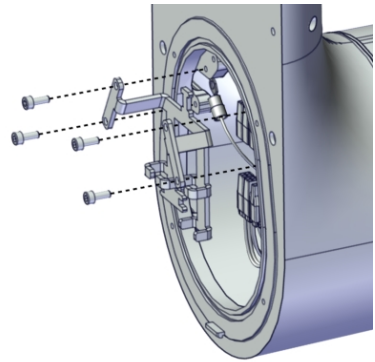
	Action	Note
1	Remove the cable bracket by removing the four screws.	 xx2000001939
2	Secure the weight of the lower arm.	

Continues on next page

5.4.1 Replacing the lower arm

Continued

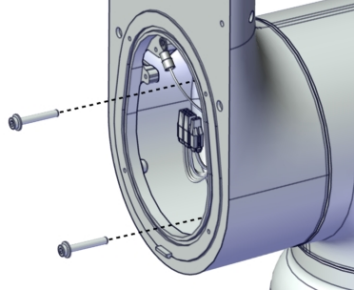
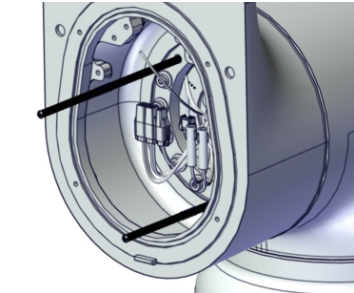
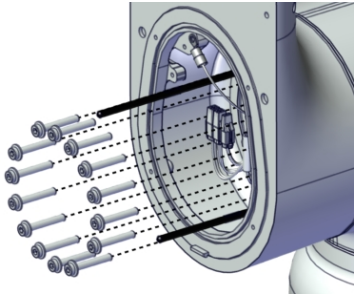
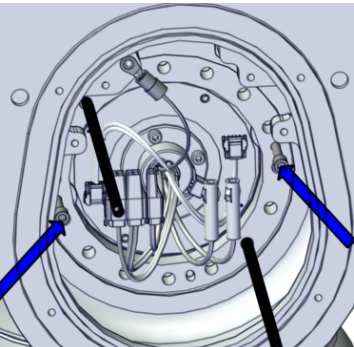
	Action	Note
3	Remove two attachment screws and fit two guide pins to the axis-2 joint unit.	<p>Valid for CRB 15000-5/0.95 Guide pin, M4x120: 3HAC077786-001</p> <p>Valid for CRB 15000-10/1.52 and CRB 15000-12/1.27 Guide pin, M5x125: 3HAC087786-001</p> <p>Always use guide pins in pairs.</p>  <p>xx2000001951</p>  <p>xx2000001960</p>
4	Remove the lower arm attachment screws.	 <p>xx2000001940</p>
5	Use two fully threaded attachment screws as removal tools to press the lower arm out of position.	 <p>xx2000002151</p>

Continues on next page

5 Repair

5.4.1 Replacing the lower arm

Continued

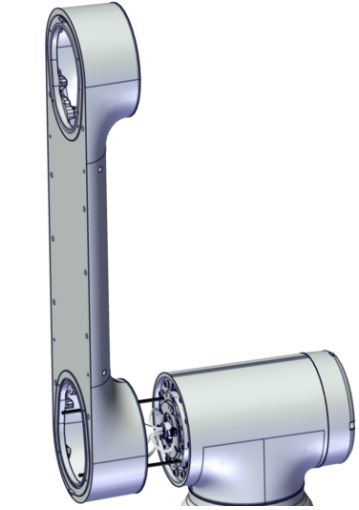
	Action	Note
6	Remove the lower arm from the swing.	 xx2000001952

Refitting the lower arm

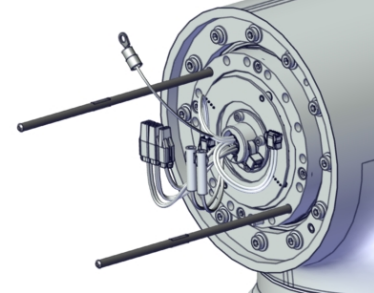

Use these procedures to refit the lower arm.

Refitting the lower arm

	Action	Note
1	Fit two guide pins to the axis-2 joint unit.	Valid for CRB 15000-5/0.95 Guide pin, M4x120: 3HAC077786-001 Valid for CRB 15000-10/1.52 and CRB 15000-12/1.27 Guide pin, M5x125: 3HAC087786-001  xx2000001949

Continues on next page

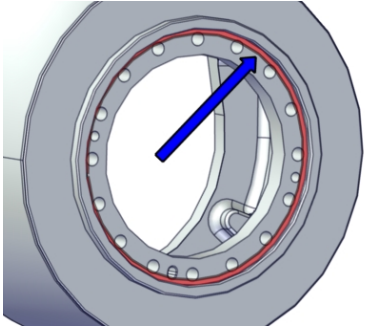
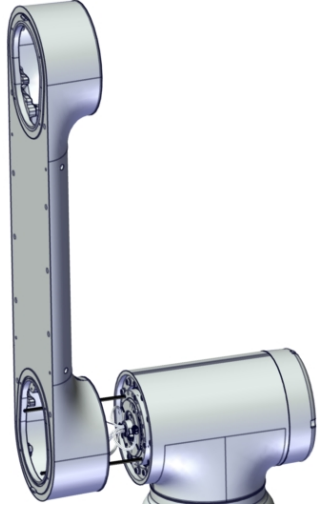
5.4.1 Replacing the lower arm
Continued

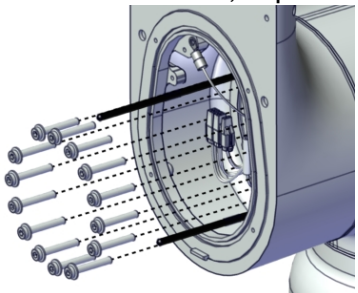
	Action	Note
2	<p>Valid for CRB 15000-5/0.95 Clean the mounting surface with isopropanol. Apply flange sealant to the corner of the lower arm mounting surface, as pointed out in the figure.</p>	<p>Cleaning agent: Isopropanol Flange sealant: Loctite 574</p>  <p>xx2000001963</p>
3	<p>Lift the lower arm to mounting position and slide it onto the guide pins.</p>	 <p>xx2000001952</p>
4	<p>Secure the lower arm to the swing with all attachment screws but two. Pre-tighten the screws crosswise firstly.</p> <p> CAUTION</p> <p>Do not mix the flange screws used for CRB 15000-5/0.95 and the threaded screws used for CRB 15000-10/1.52 and CRB 15000-12/1.27. Always use washers together with the threaded screws for CRB 15000-10/1.52 and CRB 15000-12/1.27. Illustration is for reference only.</p>	<p>Valid for CRB 15000-5/0.95 Hex socket head cap flange screw: M4x25 12.9 Lafre 2C2B/FC6.9+PrO-COat111 (16 pcs) Valid for CRB 15000-10/1.52 and CRB 15000-12/1.27 Hex socket head cap screw: M5x30 12.9 Lafre 2C2B/FC6.9, 16 pcs</p>  <p>xx2000001940</p>

Continues on next page

5 Repair

5.4.1 Replacing the lower arm

Continued

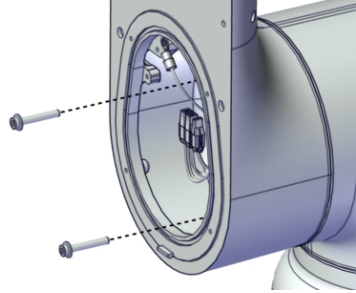
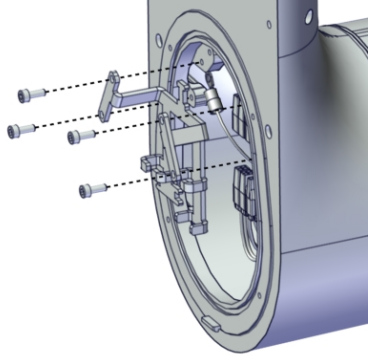
	Action	Note
5	Remove the guide pins and fasten the remaining two screws.	<p>Valid for CRB 15000-5/0.95 Hex socket head cap flange screw: M4x25 12.9 Lafre 2C2B/FC6.9+PrO-COat111 (16 pcs) Valid for CRB 15000-10/1.52 and CRB 15000-12/1.27 Hex socket head cap screw: M5x30 12.9 Lafre 2C2B/FC6.9, 16 pcs</p>  <p>xx2000001951</p>
6	Torque tighten all screws crosswise.	<p>Tightening torque: 4.6 Nm (for CRB 15000-5/0.95) / 8.2 Nm (for CRB 15000-10/1.52 and CRB 15000-12/1.27)</p>
7	Refit the cable bracket with four screws.	<p>Hex socket head cap screw: M3x8 12.9 Lafre 2C2B/FC6.9 (4 pcs). Tightening torque: 0.8 Nm</p>  <p>xx2000001939</p>

Continues on next page

Refitting the upper arm

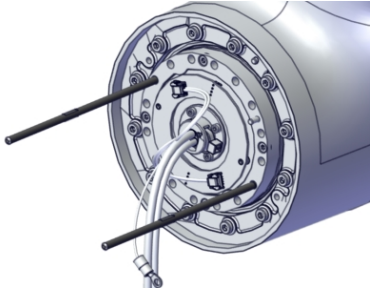
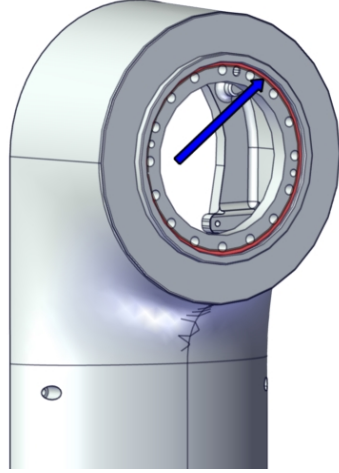
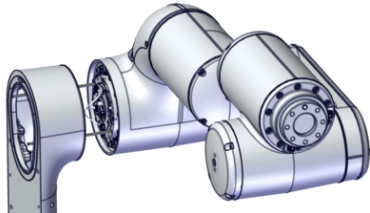
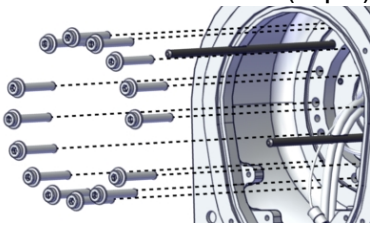
	Action	Note
1	Fit two guide pins to the axis-3 joint.	<p>Guide pin, M4x120: 3HAC077786-001</p>  <p>xx2000001971</p>
2	<p>Valid for CRB 15000-5/0.95</p> <p>Clean the mounting surface with isopropanol.</p> <p>Apply flange sealant to the corner of the lower arm mounting surface, as pointed out in the figure.</p>	<p>Cleaning agent: Isopropanol Flange sealant: Loctite 574</p>  <p>xx2000001973</p>
3	Lift the upper arm into mounting position while inserting the cabling into the lower arm.	 <p>xx2000001970</p>
4	Slide the upper arm into place on the guide pins.	
5	<p>Secure the upper arm to the lower arm with all attachment screws but two.</p> <p>Pre-tighten the screws crosswise firstly.</p>	<p>Hex socket head cap flange screw: M4x25 12.9 Lafre 2C2B/FC6.9+PrO-COat111 (16 pcs)</p>  <p>xx2000001969</p>

Continues on next page

5 Repair

5.4.1 Replacing the lower arm

Continued

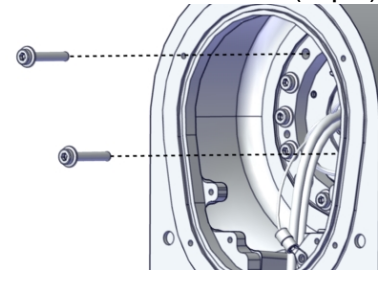
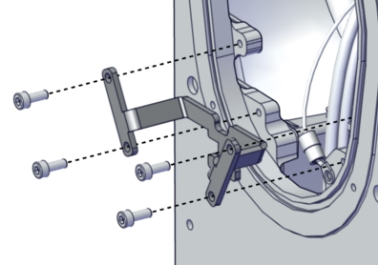
	Action	Note
6	Remove the guide pins and fasten the remaining two screws.	Hex socket head cap flange screw: M4x25 12.9 Lafre 2C2B/FC6.9+PrO-COat111 (16 pcs)  xx2000001967
7	Torque tighten all screws crosswise.	Tightening torque: 4.6 Nm
8	Refit the cable bracket with the four screws.	Hex socket head cap screw: M3x8 12.9 Lafre 2C2B/FC6.9 (4 pcs). Tightening torque: 0.8 Nm  xx2000001966

Connecting the cabling between the lower arm and swing

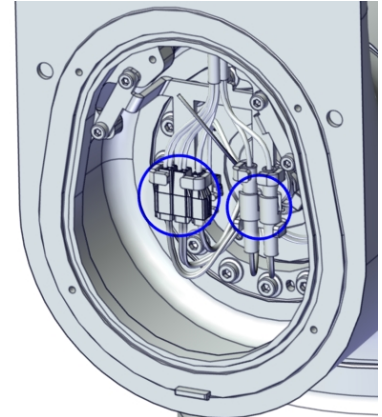
	Action	Note
1	Connect the connectors to each other and snap them to the cable holders.	 xx2000001938

Continues on next page

5.4.1 Replacing the lower arm

Continued

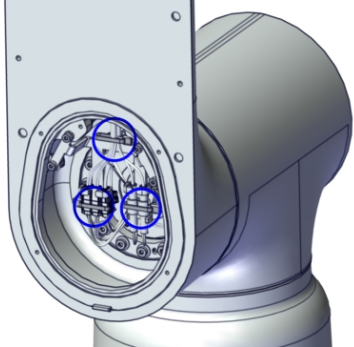
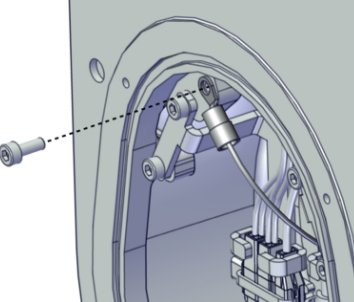
	Action	Note
2	Secure the cabling with cable ties.	<p>Cable ties (3 pcs)</p>  <p>xx2000001937</p>
3	Connect the functional earth cable with the screw.	<p>Hex socket head cap screw: M3x8 12.9 Lafre 2C2B/FC6.9 (1 pcs). Tightening torque: 0.8 Nm</p>  <p>xx2000001936</p>

Fastening the cabling between the lower and upper arm

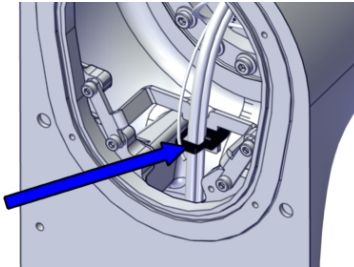
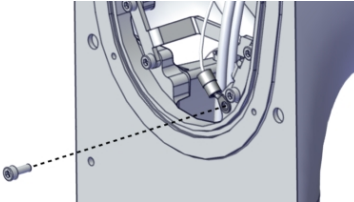
	Action	Note
1	Secure the cabling with the cable tie.	<p>Cable ties</p>  <p>xx2000001965</p>
2	Connect the functional earth cable with the screw.	<p>Hex socket head cap screw: M3x8 12.9 Lafre 2C2B/FC6.9 (1 pcs). Tightening torque: 0.8 Nm</p>  <p>xx2000001964</p>



Continues on next page

5 Repair

5.4.1 Replacing the lower arm

Continued

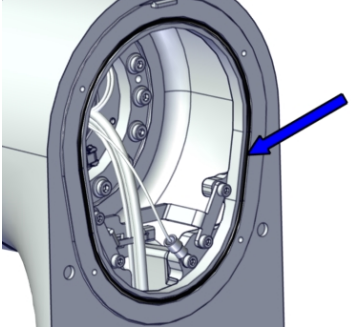
Refitting the lower arm covers (-5/0.95)

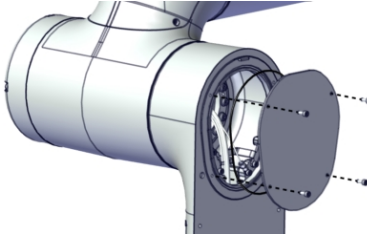
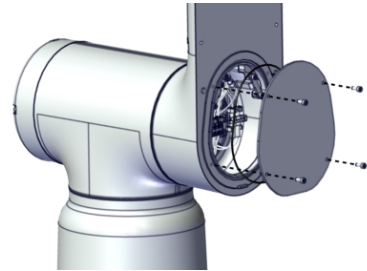
	Action	Note
1	Wipe, lubricate and fit the o-ring to its groove. Replace if damaged.	<p>O-ring: 3HAC061327-044 Grease: 3HAC042536-001 (Shell Gadus S2)</p>  <p>xx2000001955</p>  <p>xx2000001954</p>
2	Refit the inner covers with four screws each.	<p>Hex socket head cap screw: M3x8 12.9 Lafre 2C2B/FC6.9 (8 pcs) Tightening torque: 1.4 Nm.</p>  <p>xx2000001947</p>  <p>xx2000001930</p>

Continues on next page

5.4.1 Replacing the lower arm

Continued

	Action	Note
3	Snap the lower arm cover into place.	Hex socket head cap screw: M3x16 12.9 Lafre 2C2B/FC6.9 (4 pcs) Tightening torque: 0.45 Nm.
4	Secure the cover with four screws.	

Refitting the lower arm covers (-10/1.52 and -12/1.27)

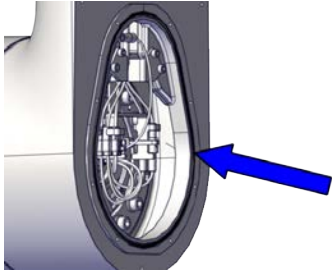
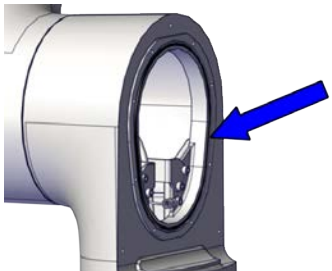
	Action	Note
1	Wipe, lubricate and fit the o-ring to its groove. Replace if damaged.	<p data-bbox="1058 1081 1342 1111">O-ring: 3HAC061327-075</p> <p data-bbox="1058 1115 1342 1144">O-ring: 3HAC061327-044</p> <p data-bbox="1058 1149 1422 1205">Grease: 3HAC042536-001 (Shell Gadus S2)</p>  <p data-bbox="1058 1480 1166 1496">xx2300000832</p>  <p data-bbox="1058 1794 1166 1809">xx2300000831</p>

Continues on next page

5 Repair

5.4.1 Replacing the lower arm

Continued

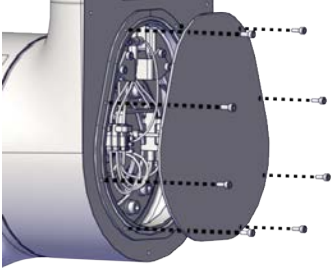
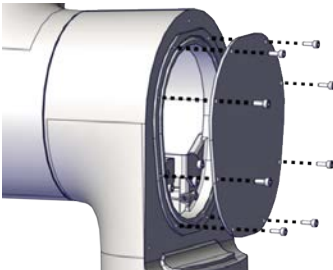
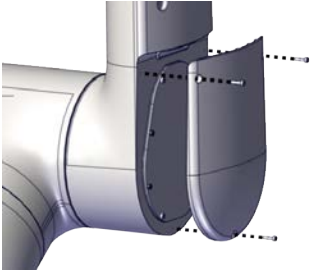
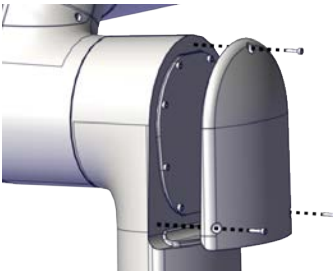
	Action	Note
2	Refit the inner covers with eight screws each.	<p>Hex socket head cap screw: M3x8 12.9 Lafre 2C2B/FC6.9 (8 pcs) x 2 Tightening torque: 1.4 Nm.</p>  <p>xx2300000813</p>  <p>xx2300000830</p>
3	Snap the lower arm cover into place.	<p>Hex socket head cap screw: M3x12 12.9 Lafre 2C2B/FC6.9 (3 pcs) x 2 Tightening torque: 1.4 Nm.</p>  <p>xx2300000812</p>  <p>xx2300000829</p>
4	Secure the cover with three screws.	

Continues on next page

Concluding procedure

	Action	Note
1	 DANGER Make sure all safety requirements are met when performing the first test run. See Test run after installation, maintenance, or repair on page 90 .	

5 Repair

5.4.2 Replacing the housing

5.4.2 Replacing the housing

Location of the housing

The housing is located as shown in the figure.

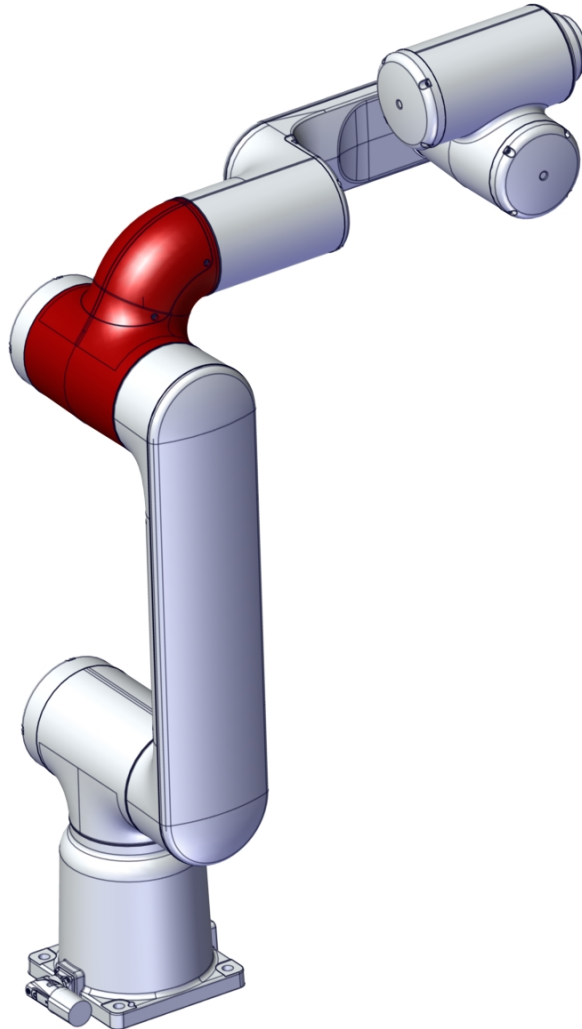

xx2000002019

Summary of the replacement procedure

This is a brief summary of the replacement procedure, containing the major actions to be performed.

- 1 Disconnect the cabling between the lower arm and the upper arm.
- 2 Remove the upper arm and place on a workbench.
- 3 Remove the axis-3 joint unit.
- 4 Remove the tubular.
- 5 Replace the housing.

Continues on next page

Required spare parts



Note

The spare part numbers that are listed in the table can be out of date. See the latest spare parts of the CRB 15000 via myABB Business Portal, www.abb.com/myABB.

Spare part	Article number	Note
Housing	3HAC073949-001	Used for CRB 15000-5/0.95. Also order new attachment screws for the axis-3 joint unit: 3HAB3413-435 (12 pcs).
Housing	3HAC087550-001	Used for CRB 15000-10/1.52 and CRB 15000-12/1.27.
Flange socket head screw with glue	3HAB3413-435	M4x35 12.9 Lafre 2C2B/FC6.9+PrO-COat111, with NYPLAS glue , 12 pcs Used for joint unit of CRB 15000-5/0.95. Always use new screws when re-fitting a joint unit. If ordering a new joint unit spare part, new screws are included.
Cable tie	3HAC075545-001	For securing joint unit cable.

Required tools and equipment

Equipment	Article number	Note
Lifting aid	3HAC077788-001	For joint units on axes 1, 2 and 3 of CRB 15000-5/0.95. Attachment screws M4x35 (4 pcs) are enclosed.
Lifting aid	3HAC087788-001	For joint unit on axis 3 of CRB 15000-10/1.52 and CRB 15000-12/1.27.
Guide pin, M4x120	3HAC077786-001	Always use guide pins in pairs. For joint units on axes 1, 2 and 3 of CRB 15000-5/0.95 and axis 3 of CRB 15000-10/1.52 and CRB 15000-12/1.27.
Guide pin, M3x110	3HAC077787-001	Always use guide pins in pairs.
Standard toolkit	-	Content is defined in section Standard toolkit on page 1099 .

Required consumables

Consumable	Article number	Note
Cleaning agent	-	Isopropanol
Flange sealant	-	Loctite 574
Cable ties	-	

Continues on next page

5 Repair

5.4.2 Replacing the housing



Continued

Consumable	Article number	Note
Gasket	3HAC075056-001	Cover inside housing Replace if damaged.
Flange socket head screw with glue	3HAB3413-435	M4x35 12.9 Lafre 2C2B/FC6.9+PrO-COat111, with NYPLAS glue , 12 pcs Used for joint unit of CRB 15000-5/0.95. Always use new screws when re-fitting a joint unit. If ordering a new joint unit spare part, new screws are included.
O-ring	3HAC061327-047	Cover for axis 2/3, used for CRB 15000-5/0.95. Replace if damaged.
O-ring	3HAC061327-047	Housing cover, used for CRB 15000-10/1.52 and CRB 15000-12/1.27. Replace if damaged.
O-ring	3HAC061327-044	Lower arm, inner cover of CRB 15000-5/0.95. 1 pcs / cover. Replace if damaged.
O-ring	3HAC061327-044	Lower arm, upper inner cover of CRB 15000-10/1.52 and CRB 15000-12/1.27. Replace if damaged.
Grease	3HAC042536-001	Shell Gadus S2

Removing the housing

Use these procedures to remove the housing.

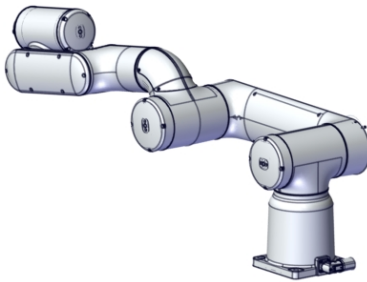
Preparations before removing the housing

	Action	Note
1	Jog the robot to the specified position: <ul style="list-style-type: none"> • Axis 1: 0° • Axis 2: +90° (suggested position for convenient working position) • Axis 3: -80° • Axis 4: 0° • Axis 5: 0° • Axis 6: 0° 	Example of CRB 15000-5/0.95, similar to CRB 15000-10/1.52 and CRB 15000-12/1.27.  xx210000002
2	 CAUTION Turn off all supplies for electrical power to the robot, before starting the repair work.	

Continues on next page

Removing the lower arm covers (-5/0.95)

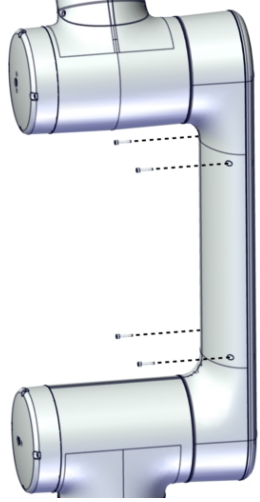
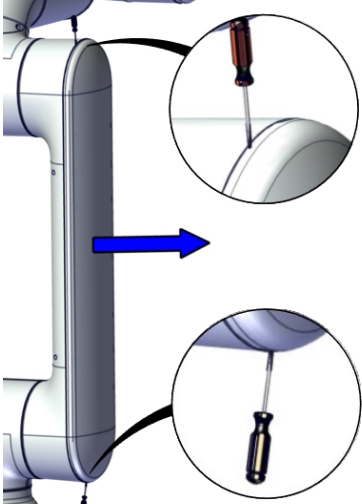
	Action	Note
1	 CAUTION Make sure that all supplies for electrical power are turned off.	
2	Remove the four lower arm cover screws.	 <p>xx2000001929</p>
3	Remove the cover by inserting a small flat screwdriver to snap open the locks at each end of the cover.	 <p>xx2100000267</p>

Continues on next page

5 Repair

5.4.2 Replacing the housing

Continued

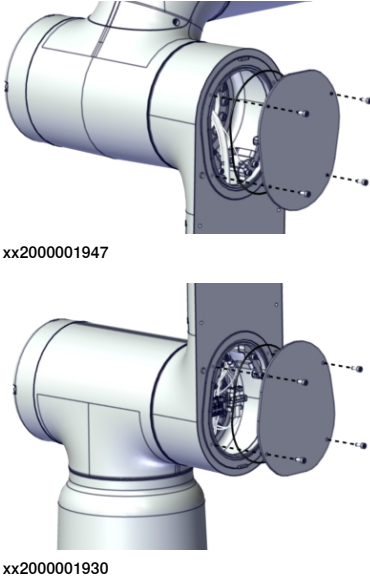
	Action	Note
4	Remove the inner covers by removing the screws.	 <p>xx2000001947</p> <p>xx2000001930</p>

Removing the lower arm covers (-10/1.52 and -12/1.27)

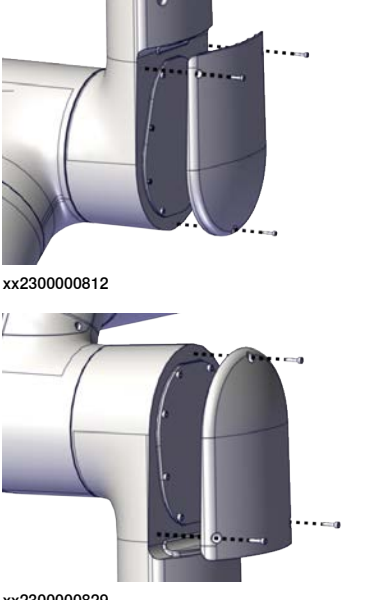
	Action	Note
1	 CAUTION Make sure that all supplies for electrical power are turned off.	
2	Remove the lower arm covers by removing the screws.	 <p>xx2300000812</p> <p>xx2300000829</p>

Continues on next page

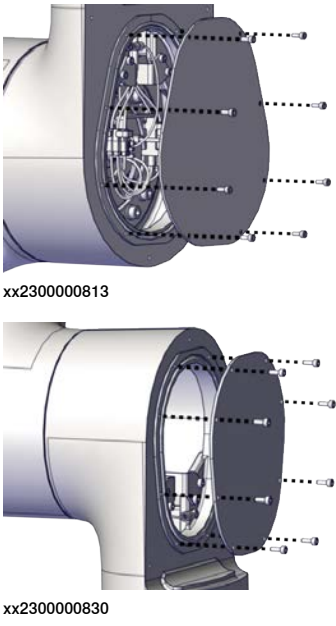
	Action	Note
3	Remove the inner covers by removing the screws.	

Disconnecting the upper arm cabling

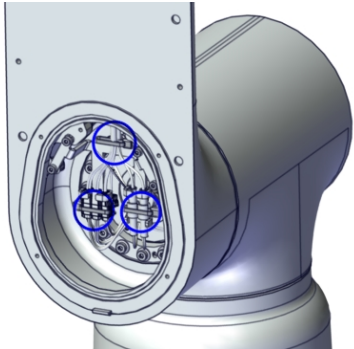
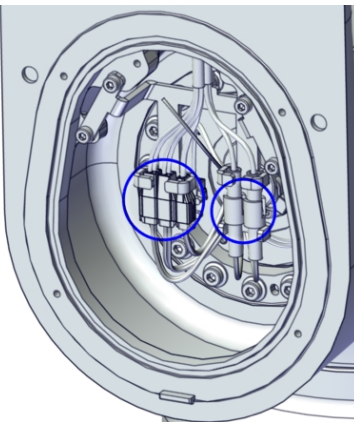
	Action	Note
1	Cut the cable ties.	
2	Snap loose and disconnect all connectors.	

Continues on next page

5 Repair



5.4.2 Replacing the housing

Continued

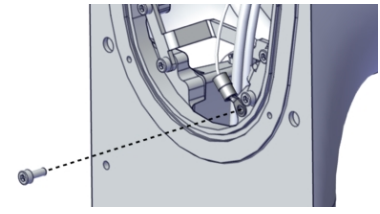
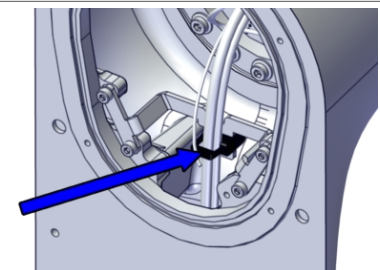
Loosening the cabling between the lower and upper arm

	Action	Note
1	Remove the functional earth cable by removing the screw.	 <p>xx2000001964</p>
2	Cut the cable tie.	 <p>xx2000001965</p>

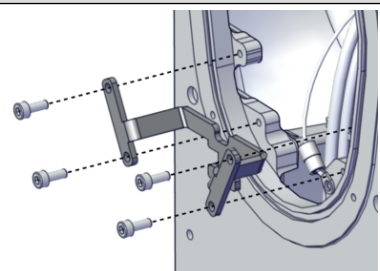
Removing the upper arm

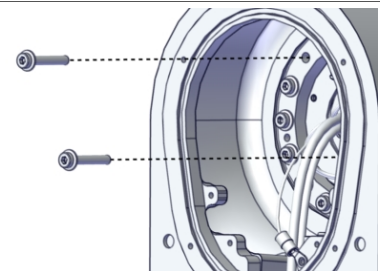
	Action	Note
1	Remove the cable bracket by removing the four screws.	 <p>xx2000001966</p>
2	Secure the weight of the upper arm.  CAUTION The weight of the complete upper arm is 14 kg.	
3	Remove two attachment screws.	 <p>xx2000001967</p>

Continues on next page

5.4.2 Replacing the housing
Continued

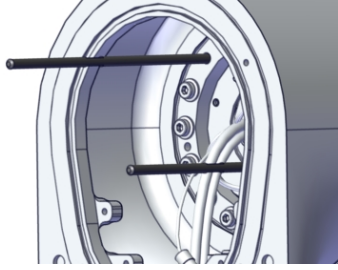
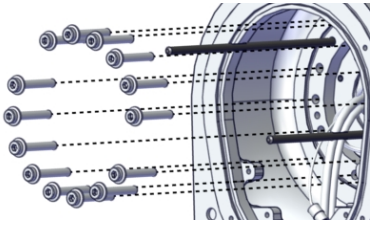
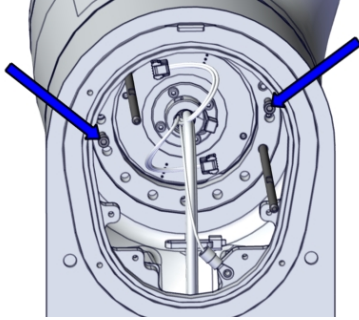
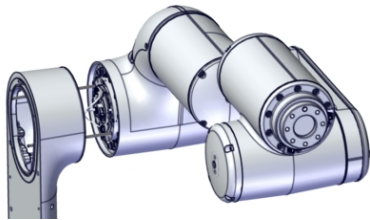
	Action	Note
4	Fit two guide pins to the axis-3 joint unit.	<p>Guide pin, M4x120: 3HAC077786-001 Always use guide pins in pairs.</p>  <p>xx2000001968</p>
5	Remove the remaining attachment screws.	 <p>xx2000001969</p>
6	Press the upper arm out of position by using two fully threaded attachment screws as removal tools.	 <p>xx2100000001</p>
7	Remove the upper arm from the lower arm. Assist the cabling to be removed from the lower arm while lifting away the complete upper arm. Place the upper arm on a workbench.	 <p>xx2000001970</p>

Removing the housing cover (-5/0.95)



	Action	Note
1	 CAUTION Make sure that all supplies for electrical power are turned off.	

Continues on next page

5 Repair

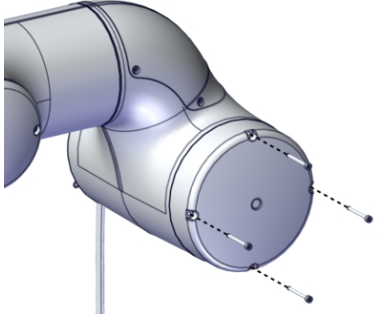

5.4.2 Replacing the housing

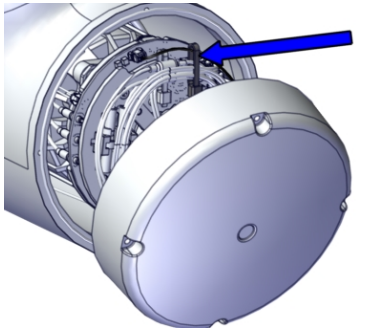
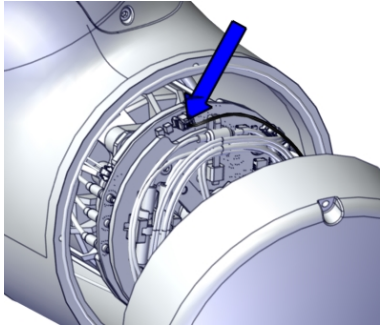
Continued

	Action	Note
2	Remove the cover screws.	 xx2000002021
3	 CAUTION Valid for CRB 15000-5/0.95 There is cabling connected between the cover and the joint unit drive board. Open the cover with care to avoid damage to the cabling or the connector(s). Do not leave the cover in location without being secured with the attachment screws.	
4	For robots with RobotWare earlier than 7.10 Open the cover and cut the cable tie that holds the brake release cable.	 xx2000002022
5	For robots with RobotWare earlier than 7.10 Disconnect the brake release connector DR.X8 from the drive board. Remove the cover.	 xx2000002023

Continues on next page

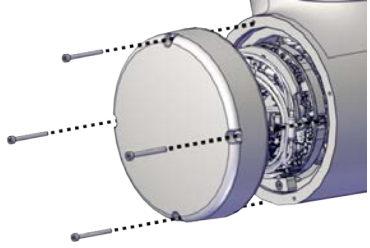
Removing the housing cover and insert (-10/1.52 and -12/1.27)

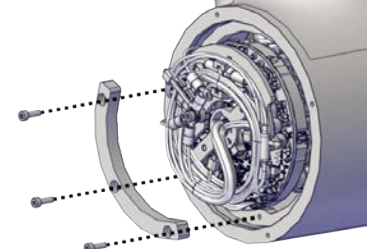
	Action	Note
1	<p> CAUTION</p> <p>Make sure that all supplies for electrical power are turned off.</p>	
2	<p>Remove the cover by removing the screws.</p>	 <p>xx2300000833</p>
3	<p> CAUTION</p> <p>Valid for CRB 15000-5/0.95</p> <p>There is cabling connected between the cover and the joint unit drive board.</p> <p>Open the cover with care to avoid damage to the cabling or the connector(s).</p> <p>Do not leave the cover in location without being secured with the attachment screws.</p>	
4	<p>Remove the insert.</p>	 <p>xx2300000834</p>

Continues on next page

5 Repair

5.4.2 Replacing the housing

Continued

Disconnecting the axis-3 joint unit cabling

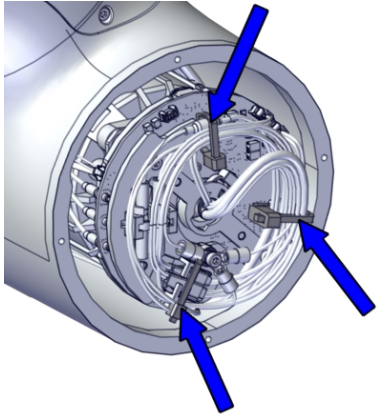
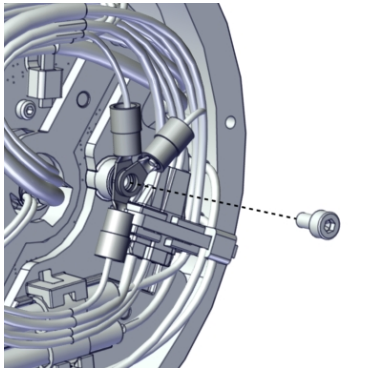
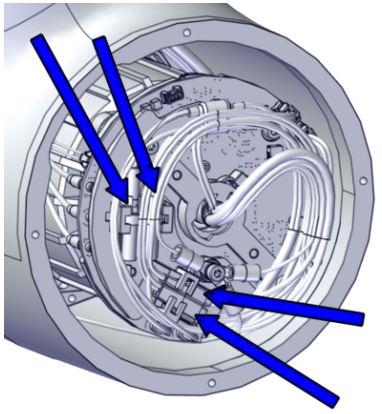
	Action	Note
1	Cut the cable ties.	 xx2000002066
2	Remove the functional and protective earth cables by removing the screw.	 xx2000001945
3	Snap loose and disconnect the connectors: <ul style="list-style-type: none">• J4.DC+• J4.DC-• J4.CS• J4.CP	 xx2000002067

Continues on next page

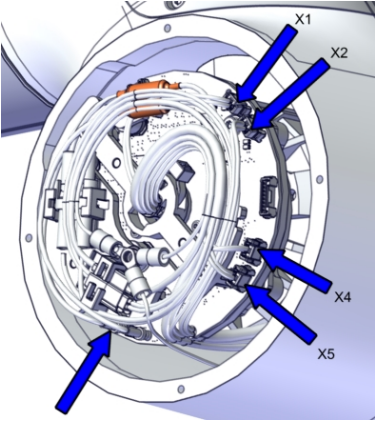
	Action	Note
4	<p>Disconnect the connectors from the drive board.</p> <ul style="list-style-type: none"> • D3.X1 • D3/4.DC+ • D3/4.DC- • D3.X4 • D3/4.X2 • D3.X5 <p> CAUTION</p> <p>Use tweezers to unlock connectors and pull them off.</p>	 <p>xx200002068</p>

Removing the axis-3 joint unit (-5/0.95)

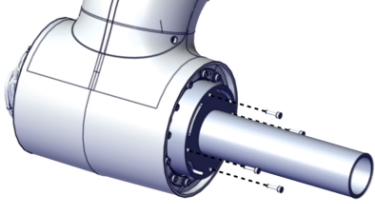
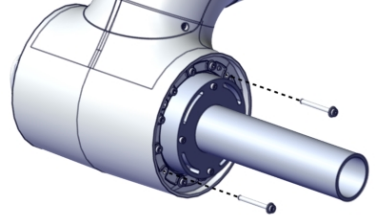
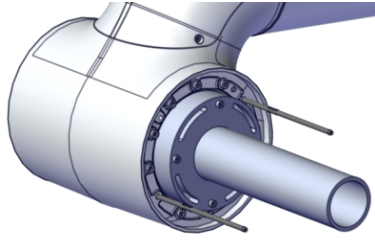



	Action	Note
1	<p>Fit the lifting aid to the joint unit, on the torque sensor side.</p> <p> CAUTION</p> <p>The connectors and the joint unit cables are sensitive to mechanical damage. Handle the assembly with care.</p>	<p>Lifting aid: 3HAC077788-001 Screws: M4x35 (4 pcs)</p>  <p>xx200002069</p>
2	<p>Remove two attachment screws. Dispose the screws. New screws are included in the spare part delivery of the joint unit.</p>	 <p>xx200002070</p>
3	<p>Fit two guide pins to the axis-3 joint unit.</p>	<p>Guide pin, M4x120: 3HAC077786-001</p> <p>Always use guide pins in pairs.</p> <p>For joint units on axes 1, 2 and 3 of CRB 15000-5/0.95 and axis 3 of CRB 15000-10/1.52 and CRB 15000-12/1.27.</p>  <p>xx200002576</p>

Continues on next page

5 Repair

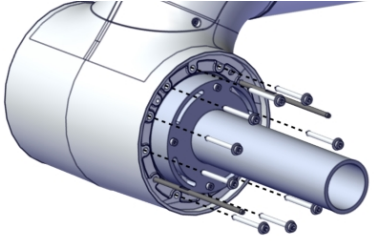

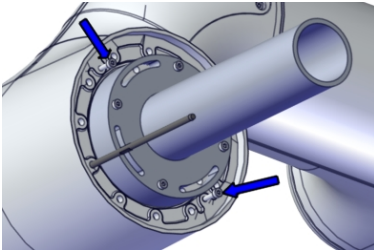

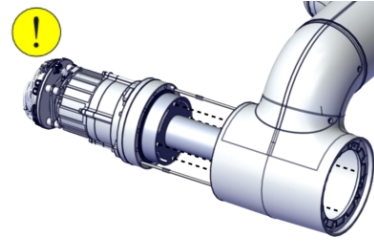
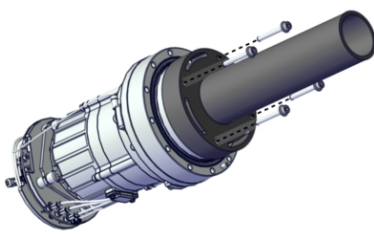

5.4.2 Replacing the housing

Continued

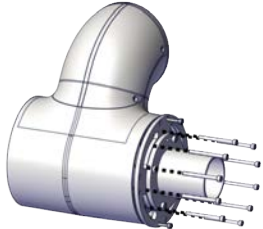
	Action	Note
4	<p>Remove the remaining attachment screws. Use two screws as press out screws in the upcoming step, then dispose all screws. New screws are included in the spare part delivery of the joint unit.</p>	 <p>xx2100000320</p>
5	<p>Put the cabling at the slot in order not to squeeze it during removal of joint unit.</p>	 <p>xx2100000003</p>
6	<p>Press the joint unit out of position using two of the previous attachment screws as removal tools.</p>	 <p>xx2000002577</p>
7	<p>Remove the joint unit from the housing.</p> <p> CAUTION</p> <p>The connectors and the joint unit cables are sensitive to mechanical damage. Handle the assembly with care.</p>	 <p>xx2000002071</p>
8	<p>Remove the lifting aid and guide pins.</p>	 <p>xx2000001957</p>

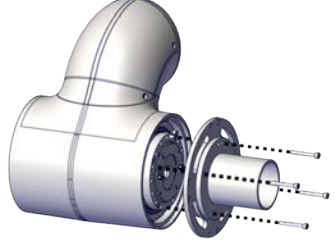
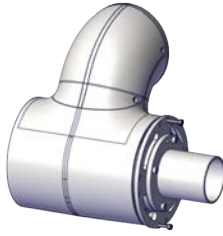
Continues on next page

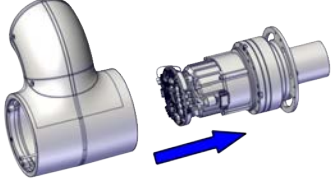
Removing the axis-3 joint unit (-10/1.52 and -12/1.27)

	Action	Note
1	Remove the attachment screws.	 <p>xx2300000799</p>
2	Fit the lifting aid to the joint unit, on the torque sensor side.  CAUTION The connectors and the joint unit cables are sensitive to mechanical damage. Handle the assembly with care.	Lifting aid: 3HAC087788-001 Screws: M4x30 (4 pcs)  <p>xx2300000800</p>
3	Use two fully attachment screws as removal tools to press the joint unit out of position.	 <p>xx2300000801</p>
4	Remove the joint unit from the housing.  CAUTION The connectors and the joint unit cables are sensitive to mechanical damage. Handle the assembly with care.	 <p>xx2300000802</p>
5	Remove the lifting aid.	 <p>xx2300000804</p>

Continues on next page

5 Repair

5.4.2 Replacing the housing

Continued

Opening the housing top cover

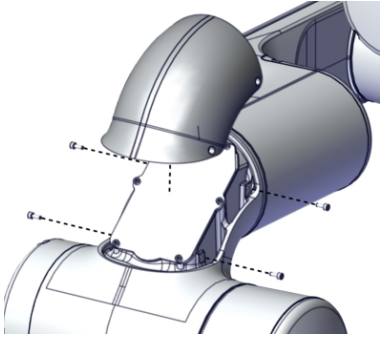
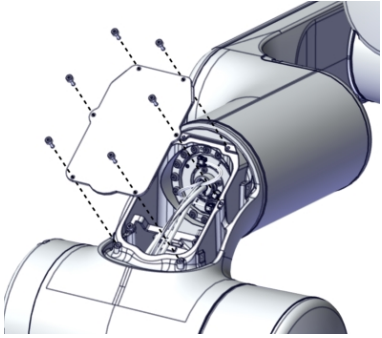
	Action	Note
1	Remove the cover by removing the four screws.	 xx2000002075
2	Remove the inner plate by removing the screws.	 xx2000002076

Removing the tubular

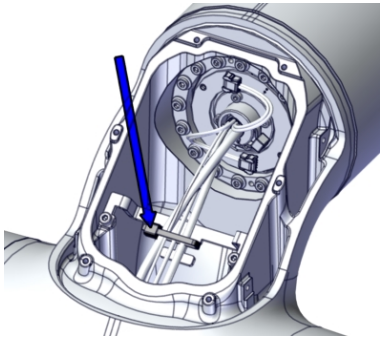
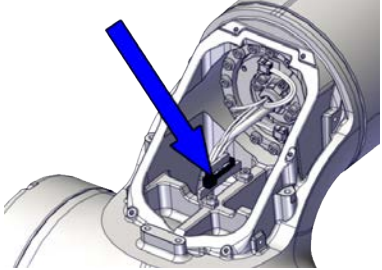
	Action	Note
1	Cut the cable tie.	<p>Valid for CRB 15000-5/0.95</p>  xx2000002077 <p>Valid for CRB 15000-10/1.52 and CRB 15000-12/1.27</p>  xx2300000839

Continues on next page

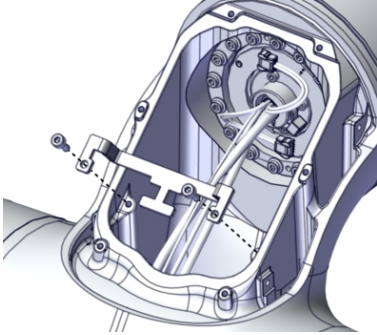
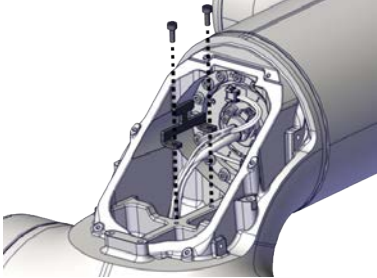
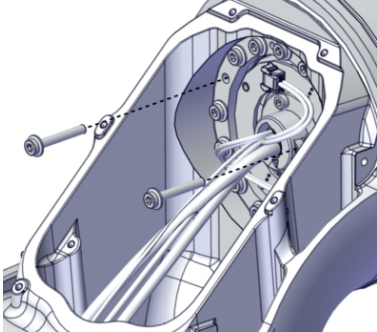
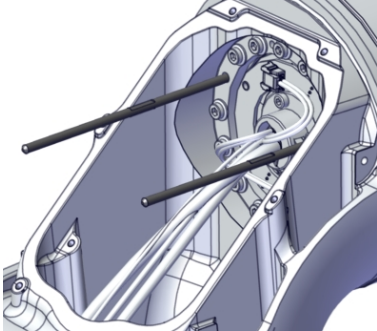
	Action	Note
2	Remove the cable bracket by removing the two screws.	<p>Valid for CRB 15000-5/0.95</p>  <p>xx2000002078</p> <p>Valid for CRB 15000-10/1.52 and CRB 15000-12/1.27</p>  <p>xx2300000840</p>
3	Remove two attachment screws and fit two guide pins to the axis-4 joint unit.	<p>Guide pin, M3x110: 3HAC077787-001 Always use guide pins in pairs.</p>  <p>xx2000002079</p>  <p>xx2000002080</p>

Continues on next page

5 Repair

5.4.2 Replacing the housing

Continued

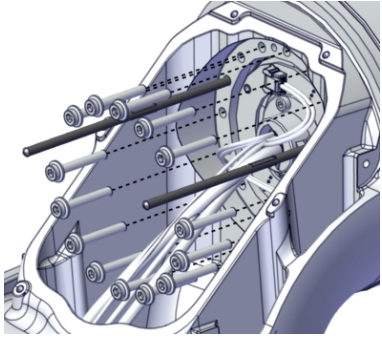
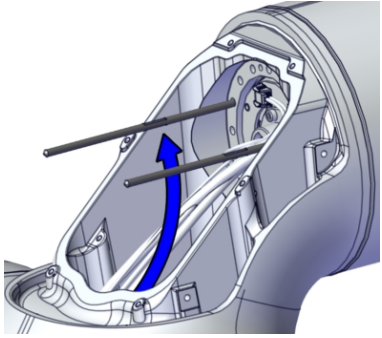
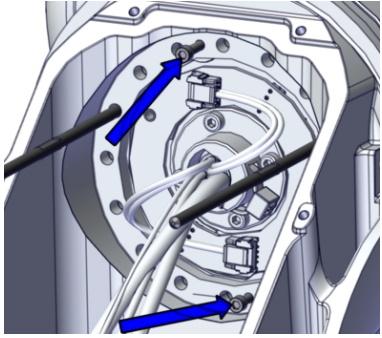
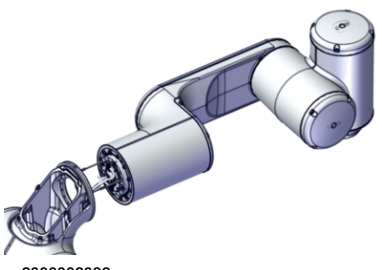
	Action	Note
4	Remove the remaining attachment screws.	 <p>xx2000002081</p>
5	Pull out the cabling carefully from the housing.	 <p>xx2000002127</p>
6	Use two fully threaded attachment screws as removal tools to press the housing out of position.	 <p>xx2100000006</p>
7	Remove the tubular from the housing. Assist the cabling to be removed from the housing while lifting away the complete tubular. Place the tubular on a workbench.	 <p>xx2000002082</p>

Replacing the housing

	Action	Note
1	Replace the housing.	Housing: 3HAC073949-001 (for CRB 15000-5/0.95) / 3HAC087550-001 (for CRB 15000-10/1.52 and CRB 15000-12/1.27)

Continues on next page

Refitting the housing

Use these procedures to refit the housing.

Refitting the tubular

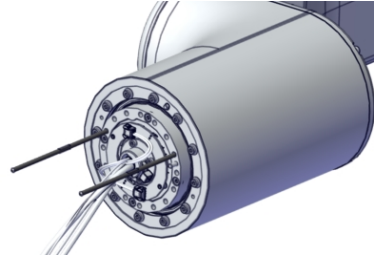
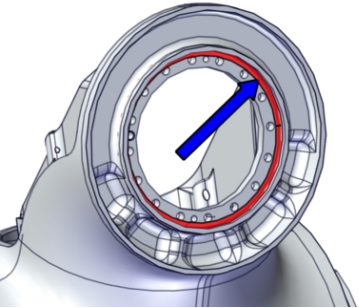
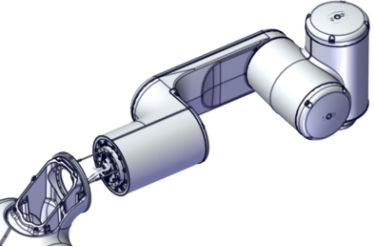
	Action	Note
1	Fit two guide pins to the axis-4 joint.	<p>Guide pin, M3x110: 3HAC077787-001 Always use guide pins in pairs.</p>  <p>xx2000002093</p>
2	<p>Clean the mounting surface with isopropanol. Apply flange sealant to the corner of the housing mounting surface, as pointed out in the figure.</p>	<p>Cleaning agent: Isopropanol Flange sealant: Loctite 574</p>  <p>xx2000002094</p>
3	Lift the tubular into mounting position while inserting the cabling into the housing.	 <p>xx2000002082</p>
4	Slide the tubular into place on the guide pins.	

Continues on next page

5 Repair

5.4.2 Replacing the housing

Continued

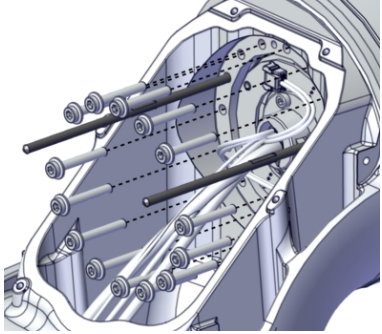
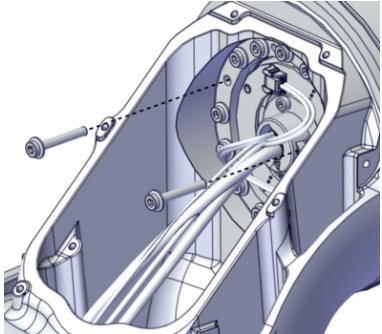
	Action	Note
5	Secure the tubular to the housing with all attachment screws but two. Pre-tighten the screws crosswise firstly.	Flange socket head screw: M3x20 12.9 Lafre 2C2B/FC6.9+PrO- COat111  xx2000002081
6	Remove the guide pins and fasten the remaining two screws.	Flange socket head screw: M3x20 12.9 Lafre 2C2B/FC6.9+PrO- COat111  xx2000002079
7	Torque tighten all screws crosswise.	Tightening torque: 1.8 Nm.

Continues on next page

5.4.2 Replacing the housing
Continued

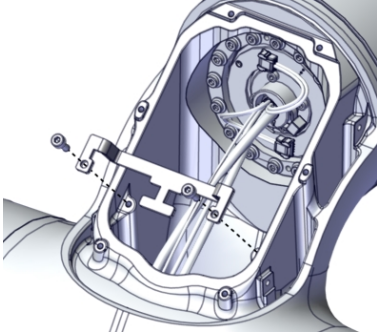
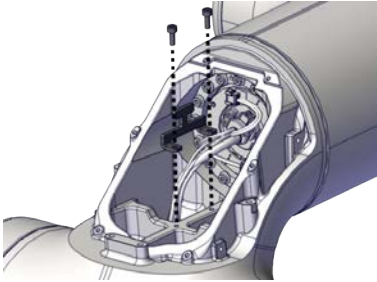
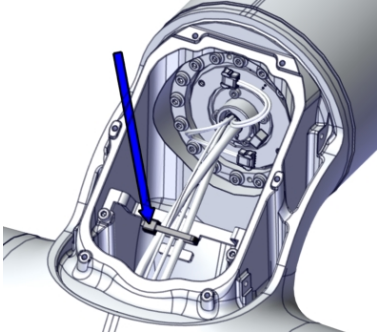
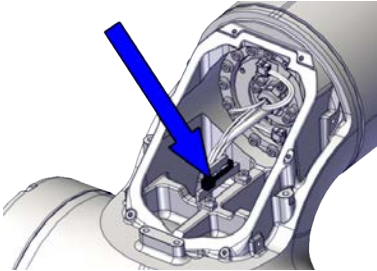
	Action	Note
8	Refit the cable bracket with the two screws.	<p>Hex socket head cap screw: M3x8 12.9 Lafre 2C2B/FC6.9 (4 pcs). Tightening torque: 0.8 Nm Valid for CRB 15000-5/0.95</p>  <p>xx2000002078</p> <p>Valid for CRB 15000-10/1.52 and CRB 15000-12/1.27</p>  <p>xx2300000840</p>
9	Secure the cabling with a cable tie.	<p>Cable ties (1 pcs) Valid for CRB 15000-5/0.95</p>  <p>xx2000002077</p> <p>Valid for CRB 15000-10/1.52 and CRB 15000-12/1.27</p>  <p>xx2300000839</p>

Continues on next page

5 Repair

5.4.2 Replacing the housing

Continued

Closing the housing top cover

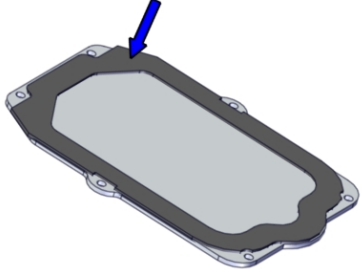
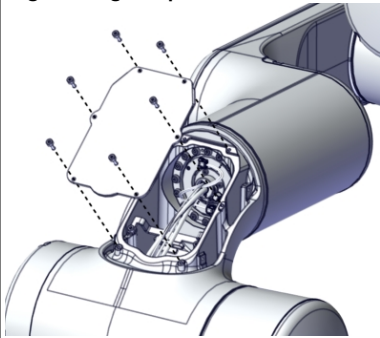
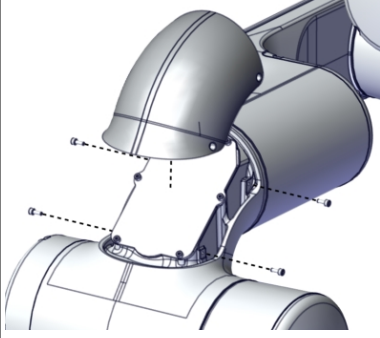

	Action	Note
1	Check the inner plate gasket. Replace if damaged.	Gasket: 3HAC075056-001  xx2000002095
2	Refit the inner plate with the screws.	Hex socket head cap screw: M3x8 12.9 Lafre 2C2B/FC6.9 (4 pcs). Tightening torque: 1.4 Nm  xx2000002076
3	Refit the cover with the four screws.	Hex socket head cap screw: M3x8 12.9 Lafre 2C2B/FC6.9 (4 pcs). Tightening torque: 0.45 Nm  xx2000002075

Preparations before fitting the joint unit

	Action	Note
1	 ELECTROSTATIC DISCHARGE (ESD) The unit is sensitive to ESD. Before handling the unit read the safety information in section The unit is sensitive to ESD on page 53 .	

Continues on next page

5.4.2 Replacing the housing
Continued

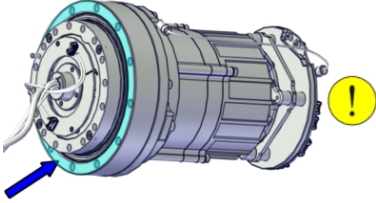
	Action	Note
2	Clean the mounting surface of the joint unit and the mating surface on the casting with isopropanol. Joint unit mounting surface is pointed out in the figure.	Cleaning agent: Isopropanol Flange sealant: Loctite 574
3	Apply a thin layer of flange sealant to the mounting surface. Do not contaminate the radial sealing with sealant.  CAUTION The connectors and the joint unit cables are sensitive to mechanical damage. Handle the assembly with care.  ELECTROSTATIC DISCHARGE (ESD) The unit is sensitive to ESD. Before handling the unit read the safety information in section The unit is sensitive to ESD on page 53 .	 xx2000001860

Refitting the axis-3 joint unit (-5/0.95)

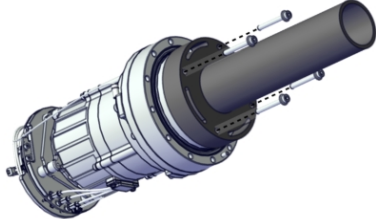
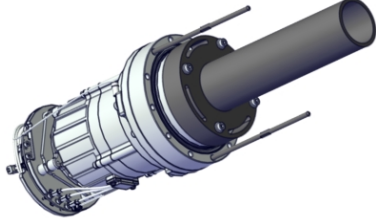

	Action	Note
1	Fit the lifting aid to the joint unit.  CAUTION The connectors and the joint unit cables are sensitive to mechanical damage. Handle the assembly with care.	Joint unit: 3HAC079141-001 Lifting aid: 3HAC077788-001 Screws: M4x35 (4 pcs)  xx2000001957
2	Fit two guide pins to the joint unit.	Guide pin, M4x120: 3HAC077786-001 Always use guide pins in pairs. For joint units on axes 1, 2 and 3 of CRB 15000-5/0.95 and axis 3 of CRB 15000-10/1.52 and CRB 15000-12/1.27.  xx2000002438

Continues on next page

5 Repair

5.4.2 Replacing the housing

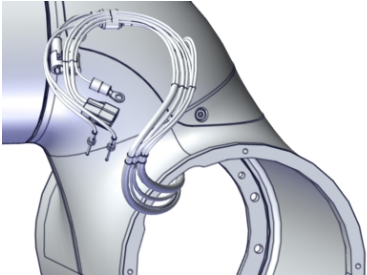
Continued

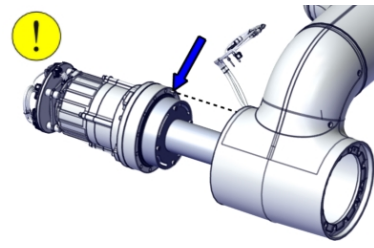
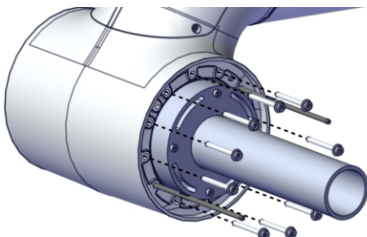
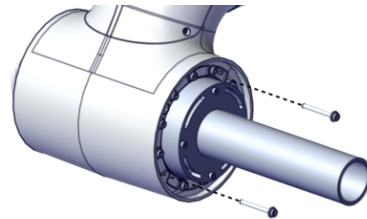
	Action	Note
3	Place the cabling at the slot before refitting the joint unit.	 <p>xx2100000004</p>
4	Fit the joint unit to the housing, aligning the pin with the pin hole.  CAUTION The connectors and the joint unit cables are sensitive to mechanical damage. Handle the assembly with care.	 <p>xx2000002072</p>
5	Secure the joint unit with new attachment screws.	Flange socket head screw with glue: 3HAB3413-435 M4x35 12.9 Lafre 2C2B/FC6.9+PrO-COat111, with NYPLAS glue , 12 pcs Used for joint unit of CRB 15000-5/0.95. Always use new screws when refitting a joint unit. If ordering a new joint unit spare part, new screws are included.  <p>xx2100000320</p>
6	Remove the guide pins and secure the remaining two attachment screws.	 <p>xx2000002070</p>
7	Pre-tighten the screws crosswise.	
8	Torque tighten all screws crosswise.	Tightening torque: 4.3 Nm.

Continues on next page

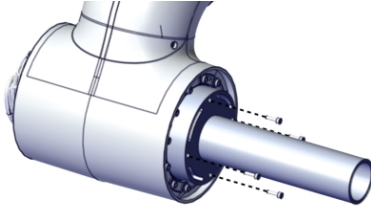
	Action	Note
9	Remove the lifting aid by removing the screws.	 xx2000002069
10	Clean pushed-out flange sealant, if any.	

Refitting the axis-3 joint unit (-10/1.52 and -12/1.27)

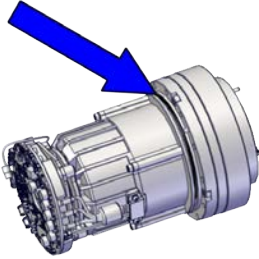
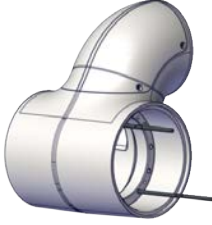

	Action	Note
1	 ELECTROSTATIC DISCHARGE (ESD) The unit is sensitive to ESD. Before handling the unit read the safety information in section <i>The unit is sensitive to ESD on page 53.</i>	
2	Check the o-ring. Replace if damaged.	O-ring: 3HAC061327-036  xx2300000836
3	Fit two guide pins to the housing.	Guide pin, M4x120: 3HAC077786-001 Always use guide pins in pairs. For joint units on axes 1, 2 and 3 of CRB 15000-5/0.95 and axis 3 of CRB 15000-10/1.52 and CRB 15000-12/1.27.  xx2300000803

Continues on next page

5 Repair

5.4.2 Replacing the housing

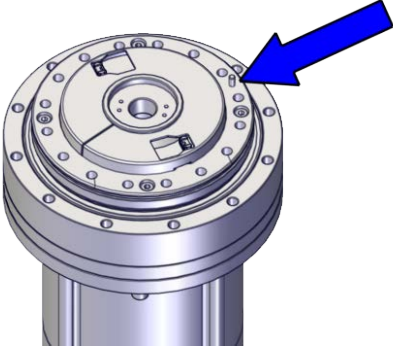
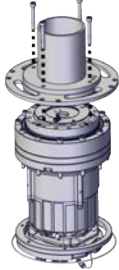
Continued

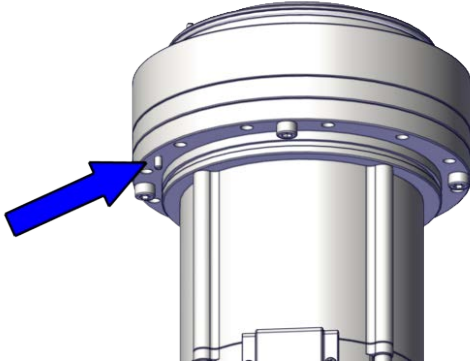
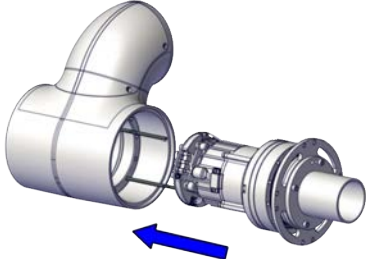
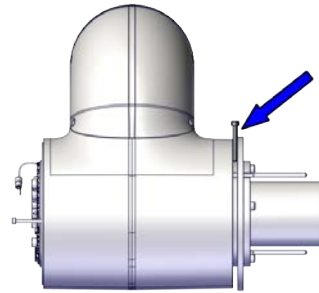
	Action	Note
4	<p>Fit the lifting aid to the joint unit, aligning the pin with the pin hole.</p> <p> CAUTION</p> <p>The connectors and the joint unit cables are sensitive to mechanical damage. Handle the assembly with care.</p>  <p>xx2300000777</p>	<p>Joint unit: 3HAC087474-001 Lifting aid: 3HAC087788-001 Screws: M4x30 (4 pcs)</p>  <p>xx2300000804</p>
5	<p>Fit the joint unit to the housing, aligning the pin with the pin hole.</p> <p> CAUTION</p> <p>The connectors and the joint unit cables are sensitive to mechanical damage. Handle the assembly with care.</p>  <p>xx2300000780</p>	 <p>xx2300000806</p>
6	<p>Check the joint unit position by placing an M4 screw between the lifting aid and housing. The joint unit is properly placed when no gaps between the lifting aid and housing.</p>	 <p>xx2300000808</p>

Continues on next page

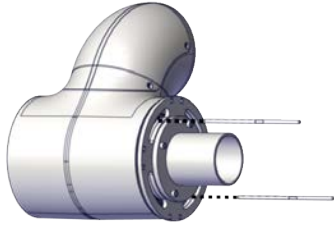
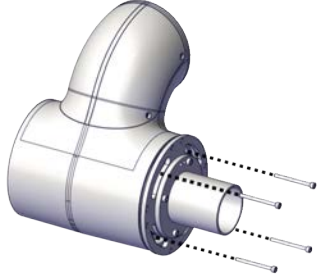
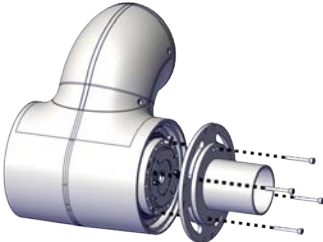
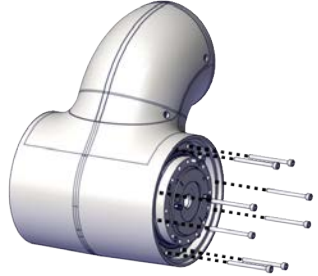
	Action	Note
7	Remove the guide pins.	 <p>xx2300000809</p>
8	Secure with four attachment screws and pre-tighten the screws crosswise.	 <p>xx2300000810</p>
9	Remove the lifting aid by removing the screws.	 <p>xx2300000800</p>
10	Secure the joint unit with the remaining attachment screws.	<p>Hex socket head cap screw: 3HAB3409-262</p>  <p>xx2300000811</p>
11	Torque tighten all screws crosswise.	<p>M4x45 12.9 Lafre 2C2B/FC6.9, 12 pcs Tightening torque: 4.3 Nm.</p>

Continues on next page

5 Repair

5.4.2 Replacing the housing

Continued

Connecting the axis-3 joint unit cabling

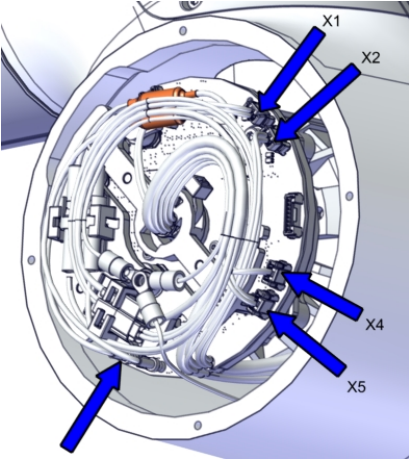
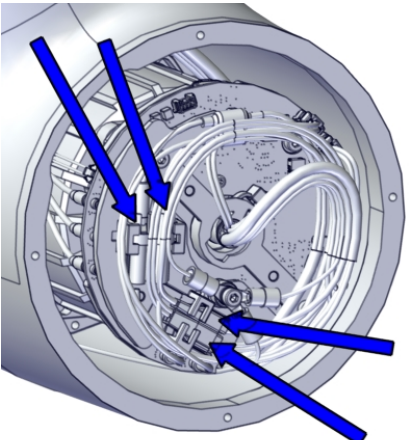
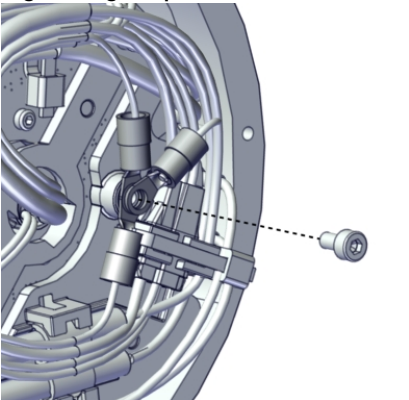
	Action	Note
1	<p>Reconnect the connectors to the drive board.</p> <ul style="list-style-type: none"> • D3.X1 to X1 • D3/4.DC+ to DC+ • D3/4.DC- to Ground • D3.X4 to X4 • D3/4.X2 to X2 • D3.X5 to X5 	 <p>xx2000002068</p>
2	<p>Connect the connectors to each other and snap them to the cable holders.</p> <ul style="list-style-type: none"> • J4.DC+ to J4/5.DC+ • J4.DC- to J4/5.DC- • J4.CS to J4/5.CS • J4.CP to J4/5.CP 	 <p>xx2000002067</p>
3	<p>Secure the cables for functional earth and protective earth with a screw.</p>	<p>Hex socket head cap screw: M3x6 (1 pcs). Tightening torque: 0.8 Nm.</p>  <p>xx2000001945</p>

Continues on next page

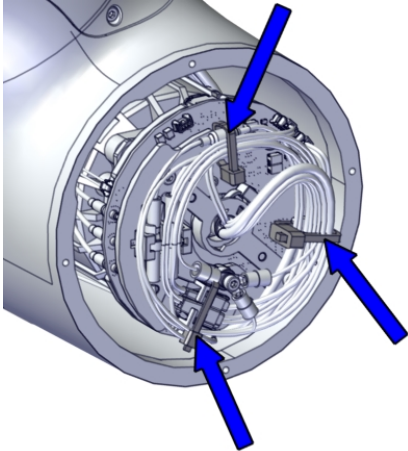
	Action	Note
4	Secure the cabling with cable ties.	<p>Cable ties (3 pcs)</p>  <p>xx2000002066</p>

Refitting the housing cover (-5/0.95)

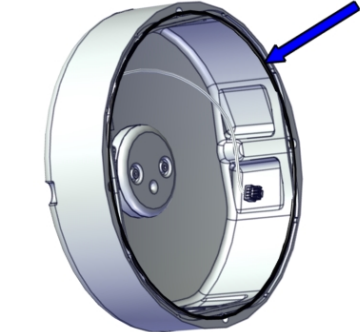
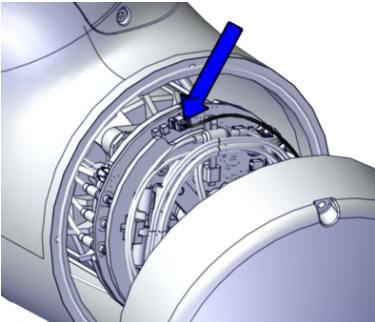
	Action	Note
1	Fit the o-ring to its groove. Replace if damaged.	<p>O-ring: 3HAC061327-047</p>  <p>xx2000001962</p>
2	<p>For robots with RobotWare earlier than 7.10</p> <p>Place the cover at mounting position and reconnect the brake release connector DR.X8 to the drive board.</p> <p>Orient the cover for proper arrangement of the brake release cable.</p>	 <p>xx2000002023</p>

Continues on next page

5 Repair

5.4.2 Replacing the housing

Continued

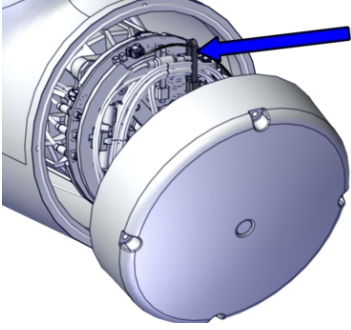
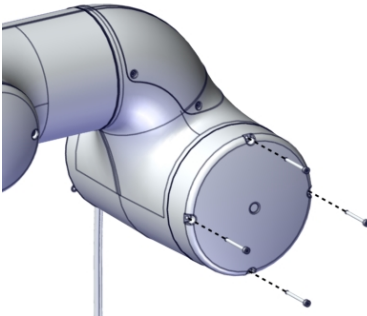
	Action	Note
3	<p>For robots with RobotWare earlier than 7.10 Secure the brake release cable with a cable tie.</p>	<p>Cable ties</p>  <p>xx2000002022</p>
4	<p>Refit the cover with the four screws.</p>	<p>Hex socket head cap screw: M3x30 12.9 Lafre 2C2B/FC6.9 (4 pcs) Tightening torque: 0.45 Nm</p>  <p>xx2000002021</p>

Refitting the housing cover and insert (-10/1.52 and -12/1.27)

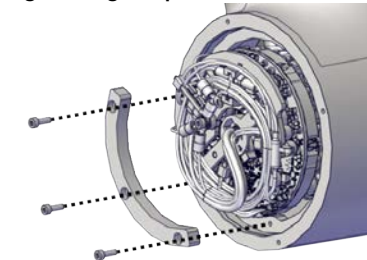
	Action	Note
1	<p>Refit the insert.</p>	<p>Insert: 3HAC084002-001 Hex socket head cap screw: M3x10 12.9 Lafre 2C2B/FC6.9 (3 pcs) Tightening torque: 1.4 Nm</p>  <p>xx2300000834</p>

Continues on next page

5.4.2 Replacing the housing
Continued

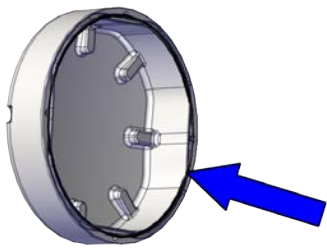
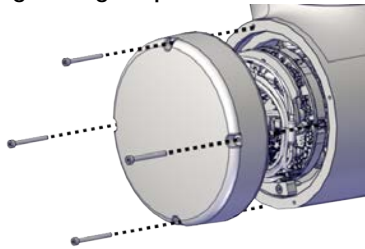
	Action	Note
2	Fit the o-ring to its groove. Replace if damaged.	O-ring: 3HAC061327-047  xx2300000835
3	Refit the cover with the four screws.	Hex socket head cap screw: M3x30 12.9 Lafre 2C2B/FC6.9 (4 pcs) Tightening torque: 1.4 Nm  xx2300000833

Refitting the upper arm

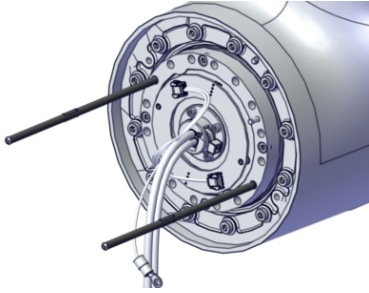
	Action	Note
1	Fit two guide pins to the axis-3 joint.	Guide pin, M4x120: 3HAC077786-001  xx2000001971

Continues on next page

5 Repair

5.4.2 Replacing the housing

Continued

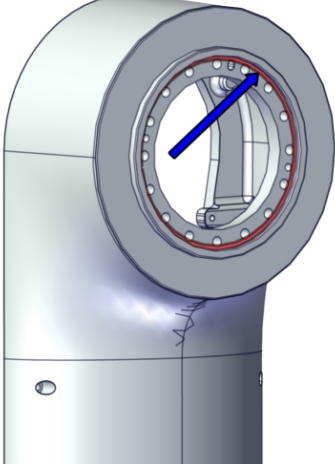
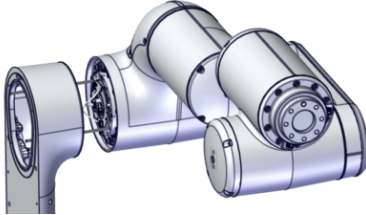
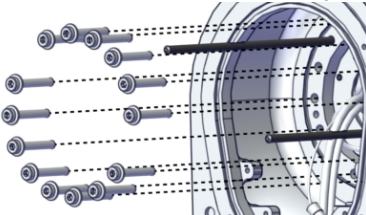
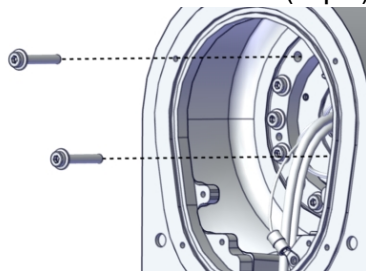
	Action	Note
2	<p>Valid for CRB 15000-5/0.95</p> <p>Clean the mounting surface with isopropanol.</p> <p>Apply flange sealant to the corner of the lower arm mounting surface, as pointed out in the figure.</p>	<p>Cleaning agent: Isopropanol Flange sealant: Loctite 574</p>  <p>xx2000001973</p>
3	Lift the upper arm into mounting position while inserting the cabling into the lower arm.	
4	Slide the upper arm into place on the guide pins.	 <p>xx2000001970</p>
5	<p>Secure the upper arm to the lower arm with all attachment screws but two.</p> <p>Pre-tighten the screws crosswise firstly.</p>	<p>Hex socket head cap flange screw: M4x25 12.9 Lafre 2C2B/FC6.9+PrO-COat111 (16 pcs)</p>  <p>xx2000001969</p>
6	Remove the guide pins and fasten the remaining two screws.	<p>Hex socket head cap flange screw: M4x25 12.9 Lafre 2C2B/FC6.9+PrO-COat111 (16 pcs)</p>  <p>xx2000001967</p>
7	Torque tighten all screws crosswise.	Tightening torque: 4.6 Nm

Continues on next page

5.4.2 Replacing the housing
Continued

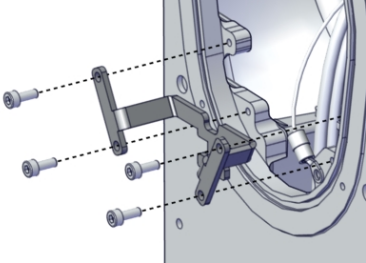
	Action	Note
8	Refit the cable bracket with the four screws.	<p>Hex socket head cap screw: M3x8 12.9 Lafre 2C2B/FC6.9 (4 pcs). Tightening torque: 0.8 Nm</p>  <p>xx2000001966</p>

Fastening the cabling between the lower and upper arm

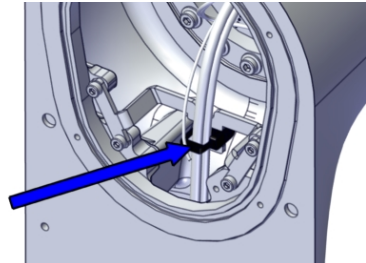
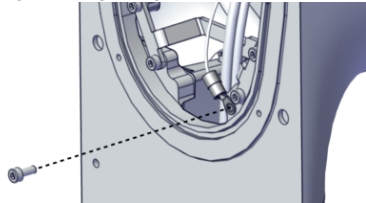
	Action	Note
1	Secure the cabling with the cable tie.	<p>Cable ties</p>  <p>xx2000001965</p>
2	Connect the functional earth cable with the screw.	<p>Hex socket head cap screw: M3x8 12.9 Lafre 2C2B/FC6.9 (1 pcs). Tightening torque: 0.8 Nm</p>  <p>xx2000001964</p>

Continues on next page

5 Repair

5.4.2 Replacing the housing

Continued

Connecting the upper arm cabling

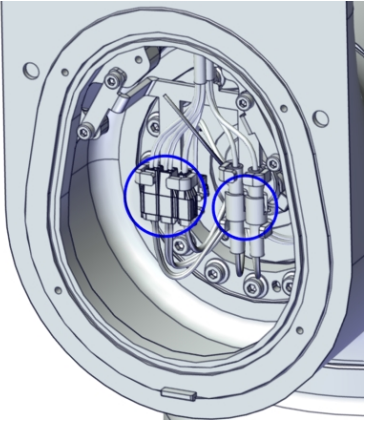
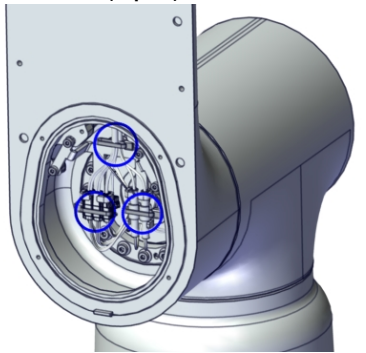
	Action	Note
1	Connect the connectors to each other and snap them to the cable holders.	 <p>xx2000001938</p>
2	Secure the cabling with cable ties.	<p>Cable ties (3 pcs)</p>  <p>xx2000001937</p>

Continues on next page

Refitting the lower arm covers (-5/0.95)

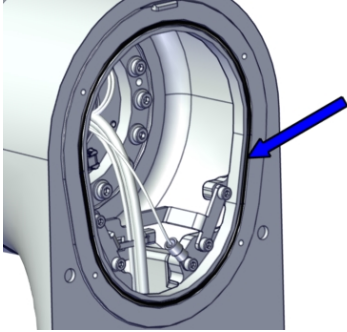
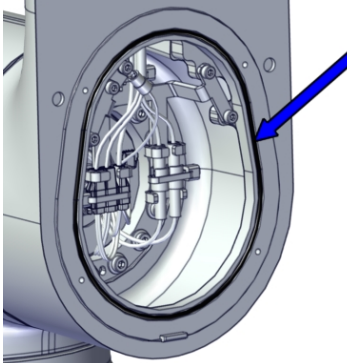
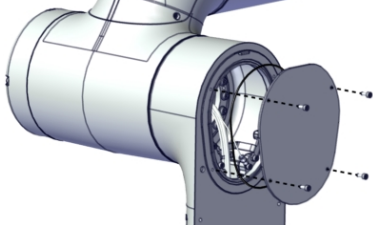
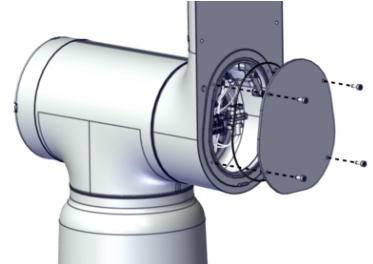
	Action	Note
1	Wipe, lubricate and fit the o-ring to its groove. Replace if damaged.	<p>O-ring: 3HAC061327-044 Grease: 3HAC042536-001 (Shell Gadus S2)</p>  <p>xx2000001955</p>  <p>xx2000001954</p>
2	Refit the inner covers with four screws each.	<p>Hex socket head cap screw: M3x8 12.9 Lafre 2C2B/FC6.9 (8 pcs) Tightening torque: 1.4 Nm.</p>  <p>xx2000001947</p>  <p>xx2000001930</p>

Continues on next page

5 Repair

5.4.2 Replacing the housing

Continued

	Action	Note
3	Snap the lower arm cover into place.	Hex socket head cap screw: M3x16 12.9 Lafre 2C2B/FC6.9 (4 pcs) Tightening torque: 0.45 Nm.
4	Secure the cover with four screws.	

Refitting the lower arm covers (-10/1.52 and -12/1.27)

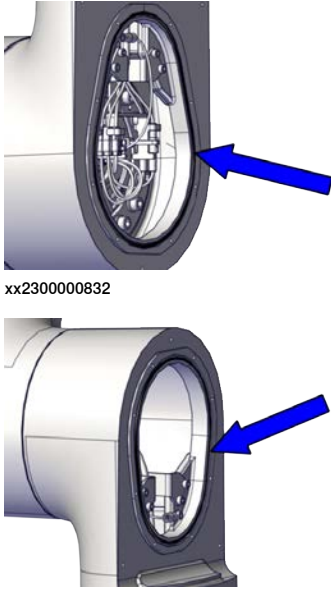
	Action	Note
1	Wipe, lubricate and fit the o-ring to its groove. Replace if damaged.	<p data-bbox="1027 1081 1310 1111">O-ring: 3HAC061327-075</p> <p data-bbox="1027 1115 1310 1144">O-ring: 3HAC061327-044</p> <p data-bbox="1027 1149 1390 1205">Grease: 3HAC042536-001 (Shell Gadus S2)</p>  <p data-bbox="1027 1480 1134 1498">xx230000832</p> <p data-bbox="1027 1798 1134 1816">xx230000831</p>

Continues on next page

5.4.2 Replacing the housing
Continued

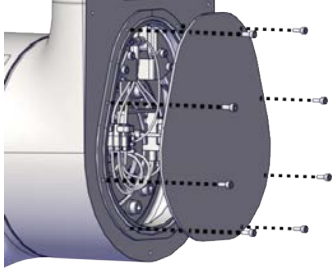
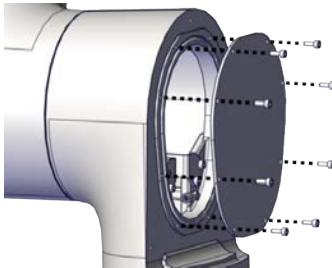
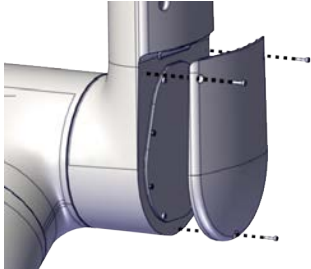
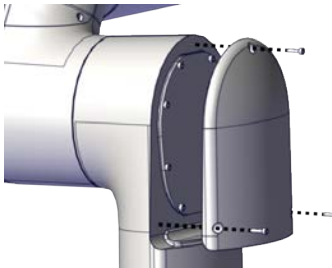
	Action	Note
2	Refit the inner covers with eight screws each.	<p>Hex socket head cap screw: M3x8 12.9 Lafre 2C2B/FC6.9 (8 pcs) x 2 Tightening torque: 1.4 Nm.</p>  <p>xx2300000813</p>  <p>xx2300000830</p>
3	Snap the lower arm cover into place.	<p>Hex socket head cap screw: M3x12 12.9 Lafre 2C2B/FC6.9 (3 pcs) x 2 Tightening torque: 1.4 Nm.</p>  <p>xx2300000812</p>  <p>xx2300000829</p>
4	Secure the cover with three screws.	

Concluding procedure

	Action	Note
1	Calibrate the axis-3 joint unit torque sensor.	See Calibration on page 1063

Continues on next page

5 Repair

5.4.2 Replacing the housing

Continued

	Action	Note
2	 DANGER Make sure all safety requirements are met when performing the first test run. See Test run after installation, maintenance, or repair on page 90 .	

5.4.3 Replacing the tubular

Location of the tubular

The tubular is located as shown in the figure.

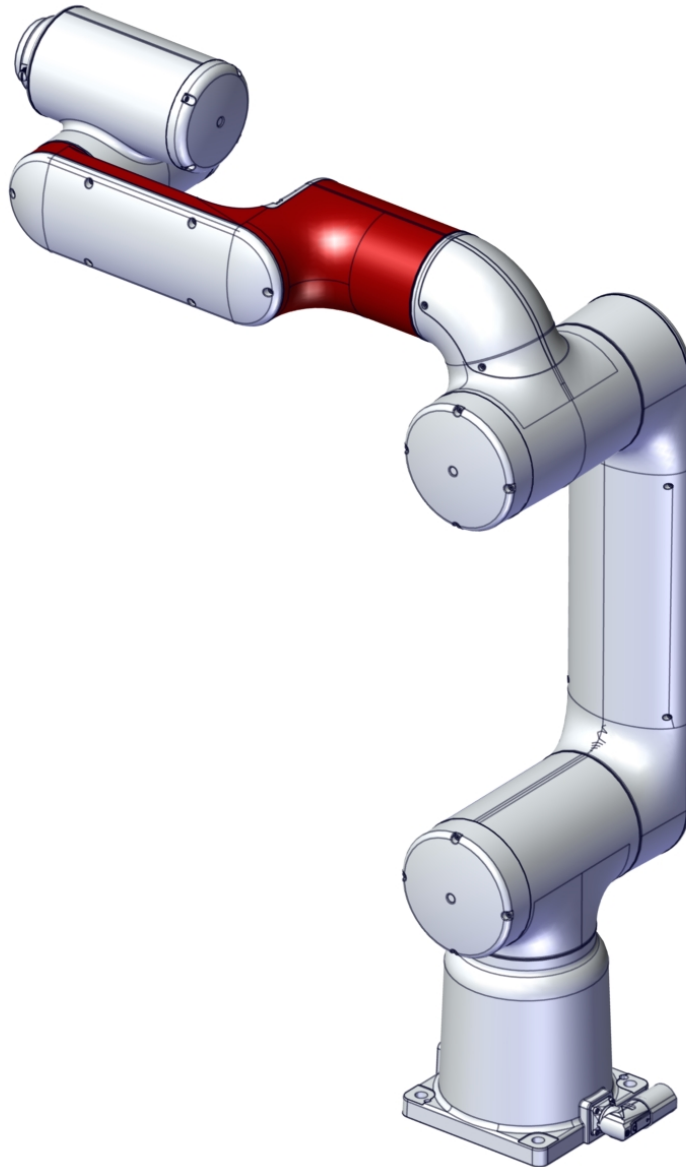

xx210000052

Summary of the replacement procedure

This is a brief summary of the replacement procedure, containing the major actions to be performed.

- 1 Separate the cabling between the housing and the tubular (at the axis-3 joint unit).
- 2 Remove the complete tubular.
- 3 Remove the axis-4 joint unit.

Continues on next page

5 Repair

5.4.3 Replacing the tubular

Continued

- 4 Remove the tilt.
- 5 Replace the tubular.

Required spare parts

 **Note**

The spare part numbers that are listed in the table can be out of date. See the latest spare parts of the CRB 15000 via myABB Business Portal, www.abb.com/myABB.

Spare part	Article number	Note
Tubular	3HAC074509-001	Used for CRB 15000-5/0.95. Also order new attachment screws for the axis-4 joint unit: 3HAB3413-330 (12 pcs).
Tubular, long	3HAC083685-001	Used for CRB 15000-10/1.52. Also order new attachment screws for the axis-4 joint unit: 3HAB3413-330 (12 pcs).
Tubular, short	3HAC081054-001	Used for CRB 15000-12/1.27. Also order new attachment screws for the axis-4 joint unit: 3HAB3413-330 (12 pcs).
Flange socket head screw with glue	3HAB3413-312	M3x12 12.9 Lafre 2C2B/FC6.9+PrO-COat111, with NYPLAS glue For tubular cover of CRB 15000-5/0.95. Always use new screws. If ordering a new axis-4 or axis-5 joint unit spare part, new screws for the tubular cover are included.
Flange socket head screw with glue	3HAB3413-330	M3x30 12.9 Lafre 2C2B/FC6.9+PrO-COat111, with NYPLAS glue , 12 pcs Used for joint unit of CRB 15000-5/0.95. Always use new screws when refitting a joint unit. If ordering a new joint unit spare part, new screws are included.
Cable tie	3HAC075545-001	For securing joint unit cable.

Required tools and equipment

Equipment	Article number	Note
Tweezers	-	Used to handle drive board connectors.
Lifting aid	3HAC077789-001	For joint units on axes 4, 5 and 6. Attachment screws M3x12 (4 pcs) are enclosed.

Continues on next page

5.4.3 Replacing the tubular
Continued

Equipment	Article number	Note
Guide pin, M3x110	3HAC077787-001	Always use guide pins in pairs. For joint units on axes 4, 5 and 6.
Standard toolkit	-	Content is defined in section Standard toolkit on page 1099 .

Required consumables

Consumable	Article number	Note
Cleaning agent	-	Isopropanol
Flange sealant	-	Loctite 574
Cable ties	-	
O-ring	3HAC061327-043	Tubular cover, used for CRB 15000-5/0.95. Replace if damaged.
O-ring	3HAB3772-166	Tubular cover, upper, used for CRB 15000-10/1.52 and CRB 15000-12/1.27. Replace if damaged.
O-ring	3HAC061327-076	Tubular cover, lower, used for CRB 15000-10/1.52 and CRB 15000-12/1.27. Replace if damaged.
Grease	3HAC042536-001	Shell Gadus S2
O-ring	3HAC061327-051	Axis-4 cover, used for CRB 15000-5/0.95. Replace if damaged.
O-ring	3HAC061327-051	Axis-4 cover, used for CRB 15000-10/1.52 and CRB 15000-12/1.27. Replace if damaged.
Gasket	3HAC075056-001	Cover inside housing Replace if damaged.
O-ring	3HAC061327-047	Cover for axis 2/3, used for CRB 15000-5/0.95. Replace if damaged.
O-ring	3HAC061327-047	Housing cover, used for CRB 15000-10/1.52 and CRB 15000-12/1.27. Replace if damaged.

Continues on next page

5 Repair



5.4.3 Replacing the tubular

Continued

Removing the tubular

Use these procedures to remove the tubular.

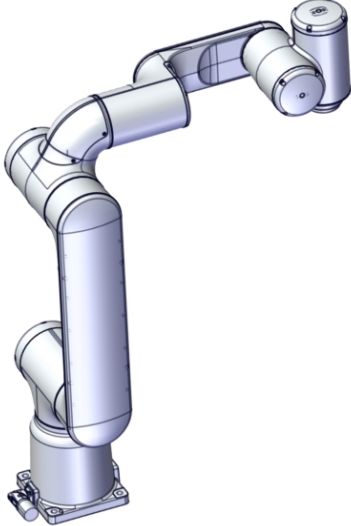
Preparations before removing the tubular

	Action	Note
1	<p>Jog the robot to the specified position:</p> <ul style="list-style-type: none"> • Axis 1: No significance. • Axis 2: 0° • Axis 3: 0° • Axis 4: 0° • Axis 5: +90° • Axis 6: No significance. 	<p>Example of CRB 15000-5/0.95, similar to CRB 15000-10/1.52 and CRB 15000-12/1.27.</p>  <p>xx210000005</p>
2	<p> CAUTION</p> <p>Turn off all supplies for electrical power to the robot, before starting the repair work.</p>	

Removing the housing cover (-5/0.95)

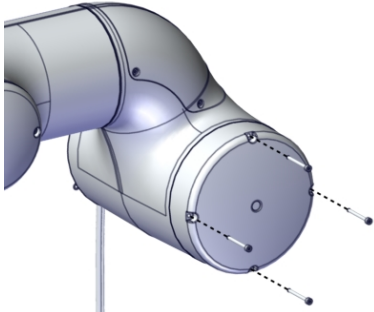
	Action	Note
1	<p> CAUTION</p> <p>Make sure that all supplies for electrical power are turned off.</p>	
2	<p>Remove the cover screws.</p>	 <p>xx200000201</p>

Continues on next page

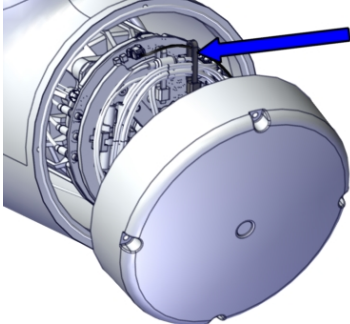
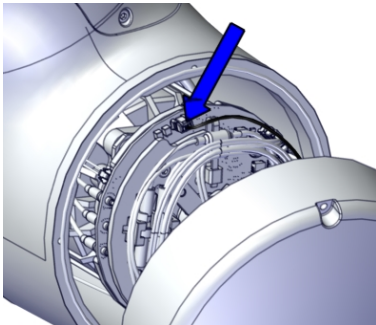
	Action	Note
3	<p> CAUTION</p> <p>Valid for CRB 15000-5/0.95</p> <p>There is cabling connected between the cover and the joint unit drive board.</p> <p>Open the cover with care to avoid damage to the cabling or the connector(s).</p> <p>Do not leave the cover in location without being secured with the attachment screws.</p>	
4	<p>For robots with RobotWare earlier than 7.10</p> <p>Open the cover and cut the cable tie that holds the brake release cable.</p>	 <p>xx2000002022</p>
5	<p>For robots with RobotWare earlier than 7.10</p> <p>Disconnect the brake release connector DR.X8 from the drive board.</p> <p>Remove the cover.</p>	 <p>xx2000002023</p>

Removing the housing cover and insert (-10/1.52 and -12/1.27)

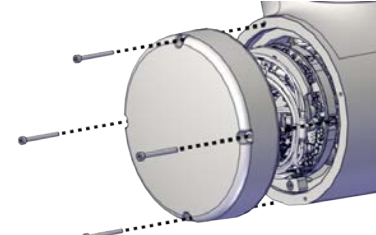
	Action	Note
1	<p> CAUTION</p> <p>Make sure that all supplies for electrical power are turned off.</p>	
2	<p>Remove the cover by removing the screws.</p>	 <p>xx2300000833</p>

Continues on next page

5 Repair

5.4.3 Replacing the tubular

Continued

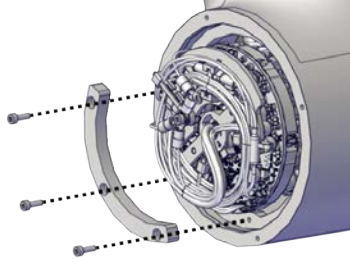
	Action	Note
3	<p> CAUTION</p> <p>Valid for CRB 15000-5/0.95</p> <p>There is cabling connected between the cover and the joint unit drive board.</p> <p>Open the cover with care to avoid damage to the cabling or the connector(s).</p> <p>Do not leave the cover in location without being secured with the attachment screws.</p>	
4	Remove the insert.	 <p>xx2300000834</p>

Separating the cabling between the housing and the tubular

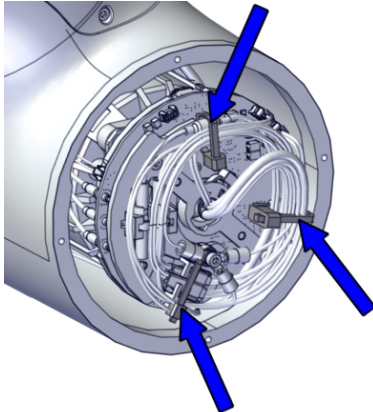
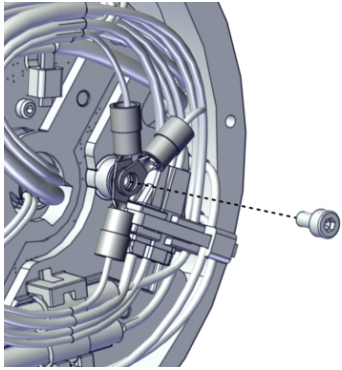
	Action	Note
1	Cut the cable ties.	 <p>xx2000002066</p>
2	Remove the functional and protective earth cables by removing the screw.	 <p>xx2000001945</p>

Continues on next page

5.4.3 Replacing the tubular
Continued

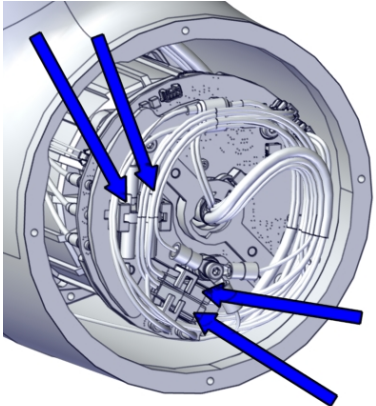
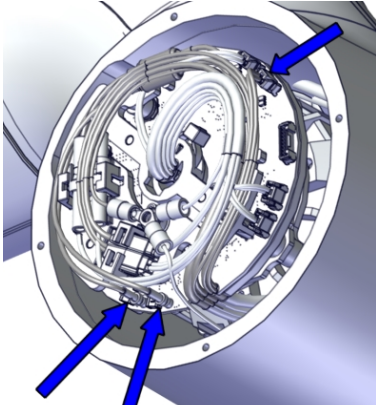
	Action	Note
3	Snap loose and disconnect the connectors: <ul style="list-style-type: none"> • J4/5.DC+ • J4/5.DC- • J4/5.CS • J4/5.CP 	 <p>xx2000002067</p>
4	Disconnect the connectors from the drive board. <ul style="list-style-type: none"> • D3/4.X2 • D3/4.DC+ • D3/4.DC- 	 <p>xx2000002120</p>

Opening the housing top cover

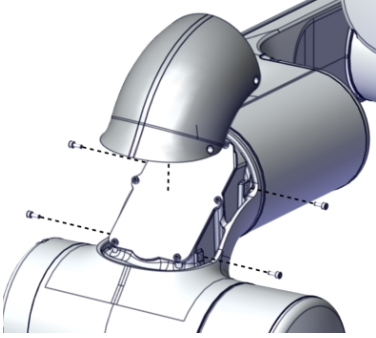
	Action	Note
1	Remove the cover by removing the four screws.	 <p>xx2000002075</p>

Continues on next page

5 Repair

5.4.3 Replacing the tubular

Continued

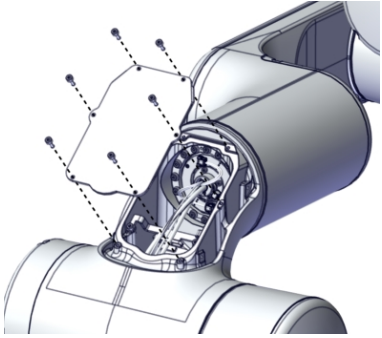
	Action	Note
2	Remove the inner plate by removing the screws.	 xx2000002076

Removing the tubular

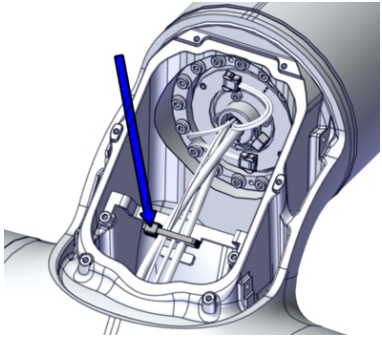
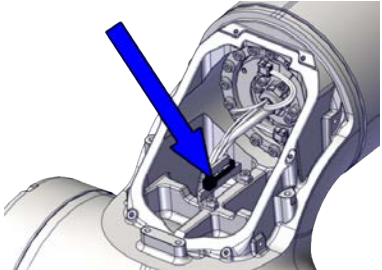
	Action	Note
1	Cut the cable tie.	Valid for CRB 15000-5/0.95  xx2000002077 Valid for CRB 15000-10/1.52 and CRB 15000-12/1.27  xx2300000839

Continues on next page

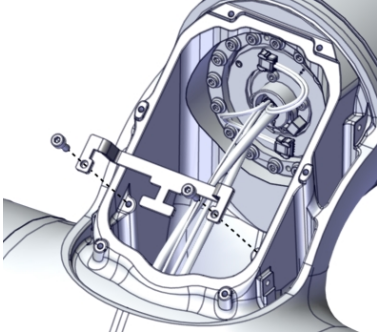
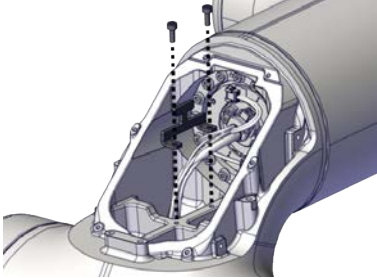
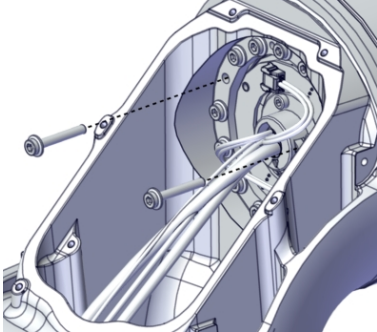
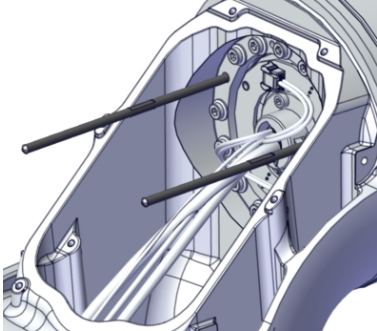
	Action	Note
2	Remove the cable bracket by removing the two screws.	<p>Valid for CRB 15000-5/0.95</p>  <p>xx2000002078</p> <p>Valid for CRB 15000-10/1.52 and CRB 15000-12/1.27</p>  <p>xx2300000840</p>
3	Remove two attachment screws and fit two guide pins to the axis-4 joint unit.	<p>Guide pin, M3x110: 3HAC077787-001 Always use guide pins in pairs.</p>  <p>xx2000002079</p>  <p>xx2000002080</p>

Continues on next page

5 Repair

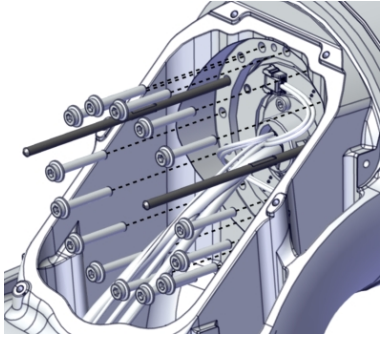
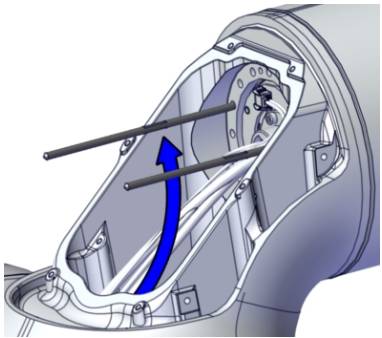
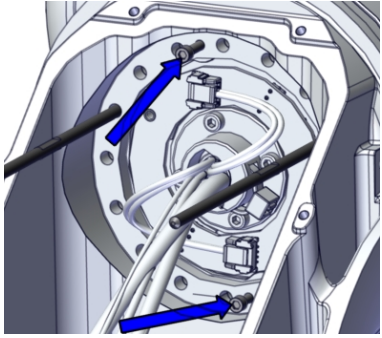
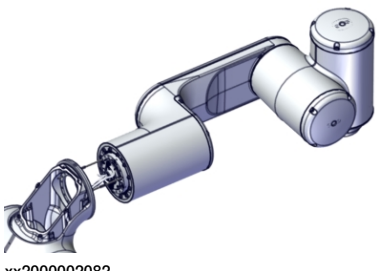

5.4.3 Replacing the tubular

Continued

	Action	Note
4	Remove the remaining attachment screws.	 xx2000002081
5	Pull out the cabling carefully from the housing.	 xx2000002127
6	Use two fully threaded attachment screws as removal tools to press the housing out of position.	 xx2100000006
7	Remove the tubular from the housing. Assist the cabling to be removed from the housing while lifting away the complete tubular. Place the tubular on a workbench.	 xx2000002082

Continues on next page

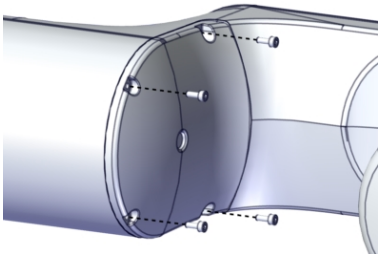
Removing the axis-4 cover

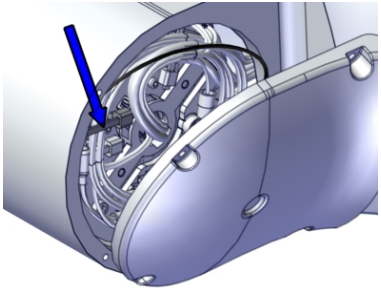
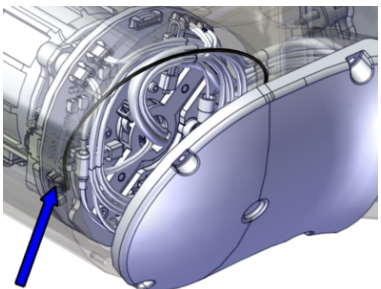
	Action	Note
1	Remove the cover screws.	 <p>xx2000002083</p>
2	<p> CAUTION</p> <p>Valid for CRB 15000-5/0.95</p> <p>There is cabling connected between the cover and the joint unit drive board.</p> <p>Open the cover with care to avoid damage to the cabling or the connector(s).</p> <p>Do not leave the cover in location without being secured with the attachment screws.</p>	
3	<p>For robots with RobotWare earlier than 7.10</p> <p>Open the cover and cut the cable tie that holds the brake release cable.</p>	 <p>xx2000002084</p>
4	<p>For robots with RobotWare earlier than 7.10</p> <p>Disconnect the brake release connector DR.X8 from the drive board.</p> <p>Remove the cover.</p>	<p>Tweezers</p>  <p>xx2000002085</p>

Continues on next page

5 Repair

5.4.3 Replacing the tubular

Continued

Removing the tubular cover

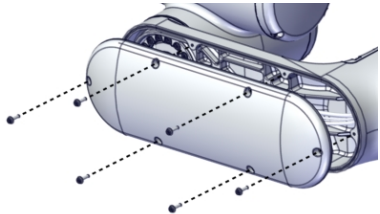
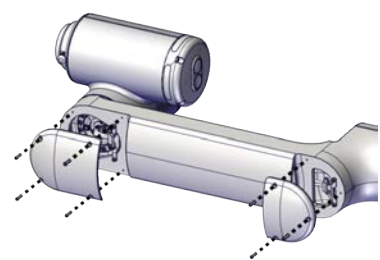
	Action	Note
1	Valid for CRB 15000-5/0.95 Remove the cover by removing the six screws. Dispose the screws. New screws must be used when refitting the cover. New screws are included in the spare part delivery of the joint unit.	 xx2000002123
2	Valid for CRB 15000-10/1.52 and CRB 15000-12/1.27 Remove the covers by removing the screws.	 xx2300000841

Separating the cabling between the tubular and the tilt

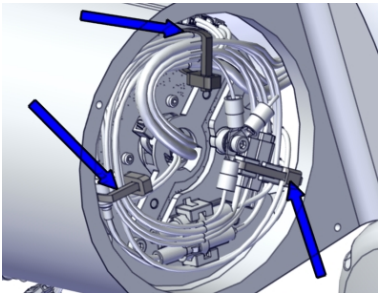
	Action	Note
1	Cut the cable ties on joint unit.	 xx2000002086

Continues on next page

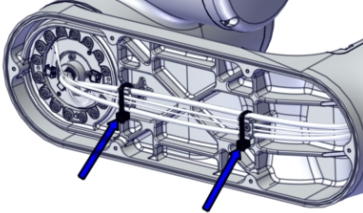
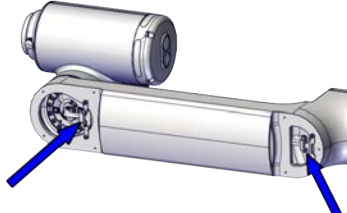
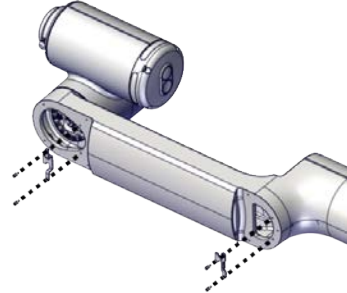
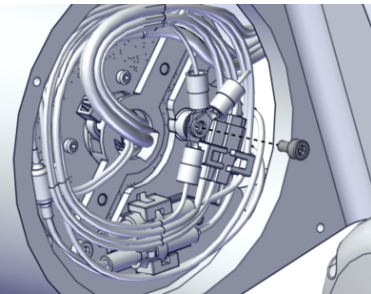
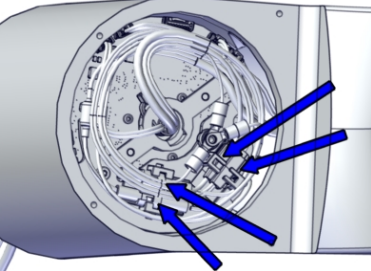
	Action	Note
2	Cut the cable ties on tubular, if needed.	<p>Valid for CRB 15000-5/0.95</p>  <p>xx2000002124</p> <p>Valid for CRB 15000-10/1.52 and CRB 15000-12/1.27</p>  <p>xx2300000842</p>
3	<p>Valid for CRB 15000-10/1.52 and CRB 15000-12/1.27</p> <p>Remove the cable brackets.</p>	 <p>xx2300000843</p>
4	Remove the functional and protective earth cables by removing the screw.	 <p>xx2000002087</p>
5	<p>Snap loose and disconnect the connectors:</p> <ul style="list-style-type: none"> • J4/5.DC+ • J4/5.DC- • J4/5.CS • J4/5.CP 	 <p>xx2000002089</p>

Continues on next page

5 Repair

5.4.3 Replacing the tubular

Continued

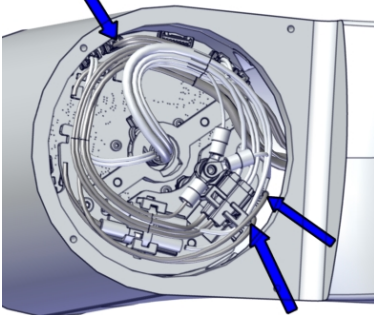
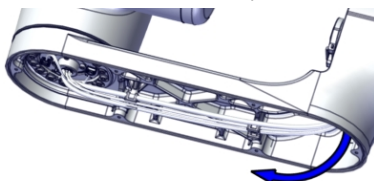
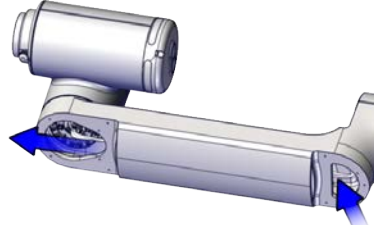
	Action	Note
6	Disconnect the connectors that belongs to the axis-5 cabling, from the axis-4 drive board: <ul style="list-style-type: none"> • D3/4.X2 • D3/4.DC- • D3/4.DC+ Use tweezers, if needed.	Tweezers  <small>xx2000002125</small>
7	Pull out the cabling carefully from the tubular.	Valid for CRB 15000-5/0.95  <small>xx2000002126</small> Valid for CRB 15000-10/1.52 and CRB 15000-12/1.27  <small>xx2300000844</small>

Disconnecting the axis-4 joint unit cabling

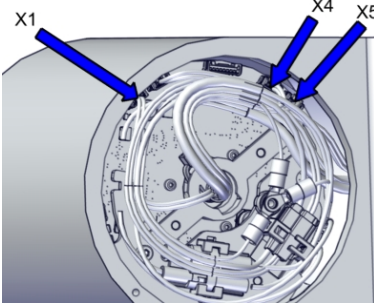
	Action	Note
1	Disconnect the connectors from the drive board.  CAUTION Use tweezers to unlock connectors and pull them off. <ul style="list-style-type: none"> • D4/5.X1 • D4/5.X4 • D4/5.X5 	Tweezers  <small>xx2000002088</small>

Continues on next page

Removing the axis-4 joint unit

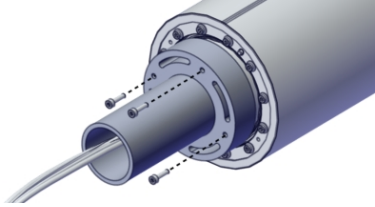
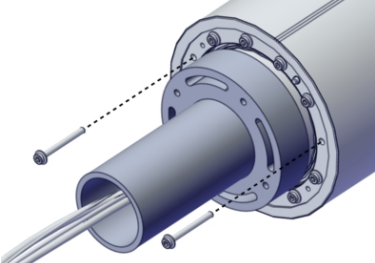
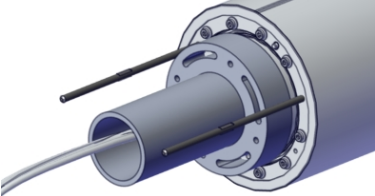
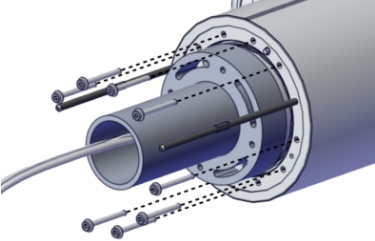
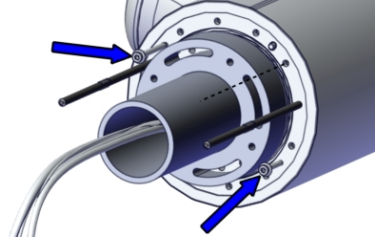
	Action	Note
1	<p>Fit the lifting aid to the joint unit, on the torque sensor side.</p> <p> CAUTION</p> <p>The connectors and the joint unit cables are sensitive to mechanical damage. Handle the assembly with care.</p>	<p>Lifting aid: 3HAC077789-001 Screws: M3x12 (4 pcs)</p>  <p>xx2000002090</p>
2	<p>Remove two attachment screws. Dispose the screws. New screws are included in the spare part delivery of the joint unit.</p>	 <p>xx2000002091</p>
3	<p>Fit two guide pins to the axis-4 joint unit.</p>	<p>Guide pin, M3x110: 3HAC077787-001 Always use guide pins in pairs. For joint units on axes 4, 5 and 6.</p>  <p>xx2000002578</p>
4	<p>Remove the remaining attachment screws. Use two screws as press out screws in the upcoming step, then dispose all screws. New screws are included in the spare part delivery of the joint unit.</p>	 <p>xx2100000326</p>
5	<p>Press the joint unit out of position using two of the previous attachment screws as removal tools.</p>	 <p>xx2100000327</p>

Continues on next page

5 Repair

5.4.3 Replacing the tubular

Continued

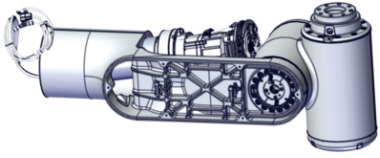
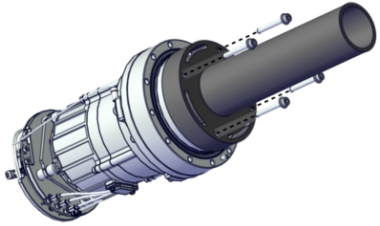
	Action	Note
6	Remove the joint unit from the tubular.  CAUTION The connectors and the joint unit cables are sensitive to mechanical damage. Handle the assembly with care.	 xx2000002116
7	Remove the lifting aid and guide pins.	 xx2000001957

Removing the tilt

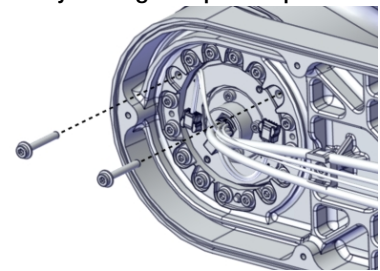
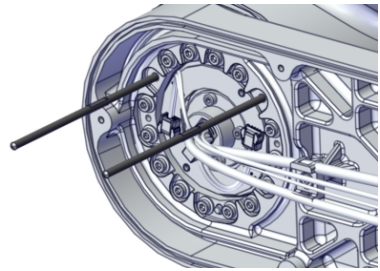
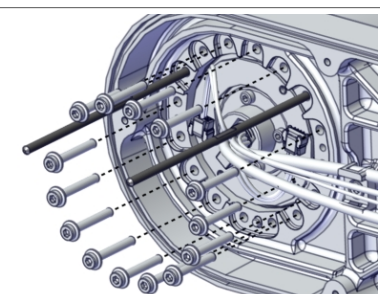
	Action	Note
1	Remove two attachment screws and fit two guide pins to the axis-5 joint unit.	Guide pin, M3x110: 3HAC077787-001 Always use guide pins in pairs.  xx2000002128  xx2000002129
2	Remove the remaining attachment screws.	 xx2000002130

Continues on next page

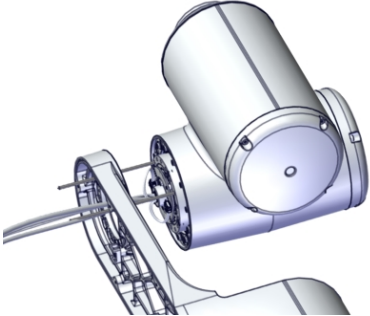
	Action	Note
3	Press the tilt out of position using two of the previous attachment screws as removal tools.	
4	Remove the tilt from the tubular. Assist the cabling to be removed while lifting away the complete tilt. Place the tilt on a workbench.	 <p>xx2000002131</p>

Replacing the tubular

	Action	Note
1	Replace the tubular.	Tubular: 3HAC074509-001 (for CRB 15000-5/0.95) Tubular: 3HAC083685-001 (for CRB 15000-10/1.52) Tubular: 3HAC081054-001 (for CRB 15000-12/1.27)

Refitting the tubular

Use these procedures to refit the tubular.

Preparations before fitting the joint unit



	Action	Note
1	 ELECTROSTATIC DISCHARGE (ESD) The unit is sensitive to ESD. Before handling the unit read the safety information in section The unit is sensitive to ESD on page 53 .	

Continues on next page



5 Repair

5.4.3 Replacing the tubular

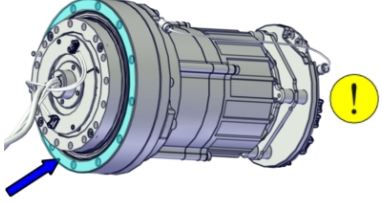

Continued

	Action	Note
2	Clean the mounting surface of the joint unit and the mating surface on the casting with isopropanol. Joint unit mounting surface is pointed out in the figure.	Cleaning agent: Isopropanol Flange sealant: Loctite 574
3	Apply a thin layer of flange sealant to the mounting surface. Do not contaminate the radial sealing with sealant.  CAUTION The connectors and the joint unit cables are sensitive to mechanical damage. Handle the assembly with care.  ELECTROSTATIC DISCHARGE (ESD) The unit is sensitive to ESD. Before handling the unit read the safety information in section The unit is sensitive to ESD on page 53 .	 xx2000001860

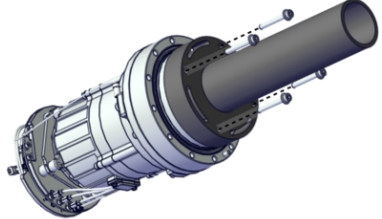
Refitting the axis-4 joint unit

	Action	Note
1	 CAUTION Axis-4 joint unit used for CRB 15000-5/0.95 has the same appearance as that used for CRB 15000-10/1.52 and CRB 15000-12/1.27. Do not mix the joint units for different manipulator variants. Always check the mark or label on the joint units before refitting.	
2	Fit the lifting aid to the joint unit.  CAUTION The connectors and the joint unit cables are sensitive to mechanical damage. Handle the assembly with care.	Joint unit: 3HAC079143-001 (for CRB 15000-5/0.95) / 3HAC087546-001 (for CRB 15000-10/1.52 and CRB 15000-12/1.27) Lifting aid: 3HAC077789-001 Screws: M3x12 (4 pcs)  xx2000001957

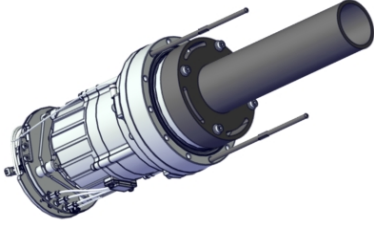
Continues on next page

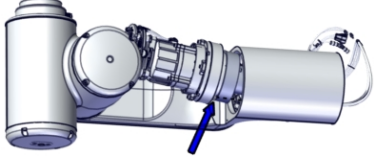
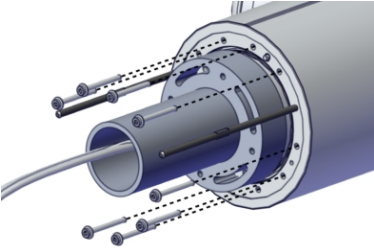
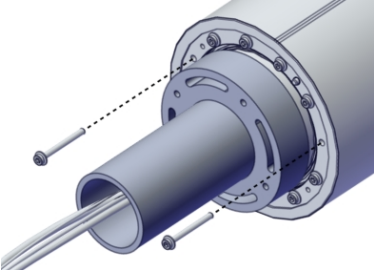
	Action	Note
3	Fit two guide pins to the joint unit.	<p>Guide pin, M3x110: 3HAC077787-001</p> <p>Always use guide pins in pairs.</p> <p>For joint units on axes 4, 5 and 6.</p>  <p>xx2000002438</p>
4	<p>Fit the joint unit to the tubular, aligning the pin with the pin hole.</p> <p> CAUTION</p> <p>The connectors and the joint unit cables are sensitive to mechanical damage. Handle the assembly with care.</p>	 <p>xx2000002117</p>
5	Secure the joint unit with new attachment screws.	<p>Flange socket head screw with glue: 3HAB3413-330</p> <p>M3x30 12.9 Lafre 2C2B/FC6.9+PrO-COat111, with NYPLAS glue , 12 pcs</p> <p>Always use new screws when refitting a joint unit. If ordering a new joint unit spare part, new screws are included.</p>  <p>xx2100000326</p>
6	Remove the guide pins and secure the remaining two attachment screws.	 <p>xx2000002091</p>
7	Pre-tighten the screws crosswise.	

Continues on next page

5 Repair

5.4.3 Replacing the tubular

Continued

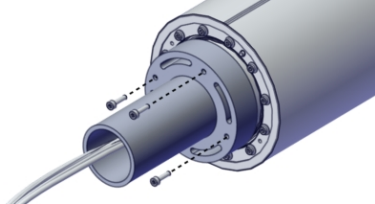
	Action	Note
8	Torque tighten all screws crosswise.	Tightening torque: 1.4 Nm (for CRB 15000-5/0.95) / 1.9 Nm (for CRB 15000-10/1.52 and CRB 15000-12/1.27)
9	Remove the lifting aid by removing the screws.	 xx2000002090
10	Clean pushed-out flange sealant, if any.	

Connecting the axis-4 joint unit cabling

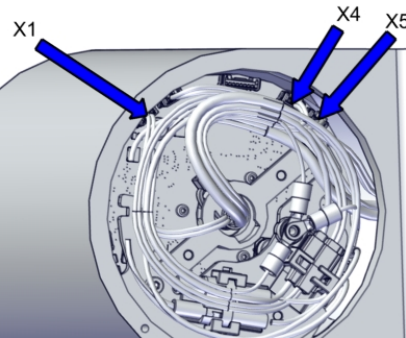
	Action	Note
1	Reconnect the connectors to the drive board. <ul style="list-style-type: none"> • D4/5.X1 to X1 • D4/5.X4 to X4 • D4/5.X5 to X5 	 xx2000002088

Refitting the tilt

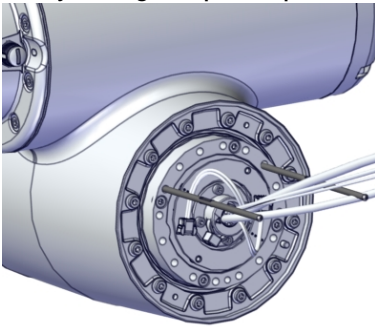
	Action	Note
1	Fit two guide pins to the axis-5 joint.	Guide pin, M3x110: 3HAC077787-001 Always use guide pins in pairs.  xx2000002146

Continues on next page

5.4.3 Replacing the tubular Continued

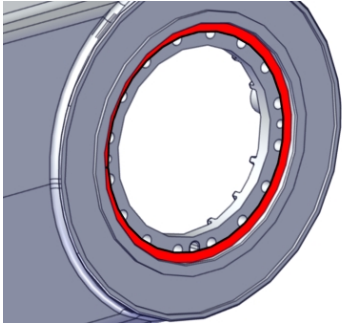
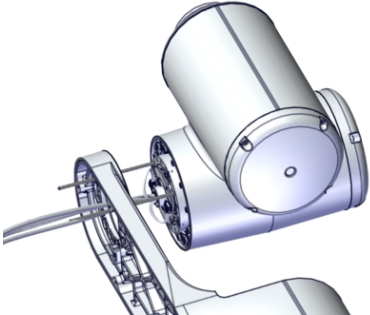
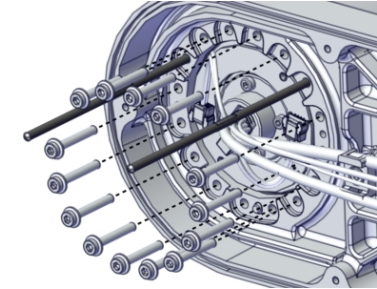
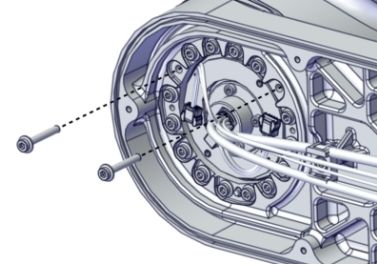
	Action	Note
2	Clean the mounting surface with isopropanol. Apply flange sealant to the corner of the tubular mounting surface, as pointed out in the figure.	<p>Cleaning agent: Isopropanol Flange sealant: Loctite 574</p>  <p>xx2000002147</p>
3	Lift the tilt into mounting position while inserting the cabling into the tubular.	 <p>xx2000002131</p>
4	Slide the tilt into place on the guide pins.	
5	Secure the tilt to the tubular with all attachment screws but two. Pre-tighten the screws crosswise firstly.	<p>Flange socket head screw: M3x20 12.9 Lafre 2C2B/FC6.9+PrO- COat111 (14 pcs)</p>  <p>xx2000002130</p>
6	Remove the guide pins and fasten the remaining two screws.	<p>Flange socket head screw: M3x20 12.9 Lafre 2C2B/FC6.9+PrO- COat111 (2 pcs)</p>  <p>xx2000002128</p>
7	Torque tighten all screws crosswise.	Tightening torque: 1.8 Nm.

Continues on next page

5 Repair

5.4.3 Replacing the tubular

Continued

Connecting the tilt cabling

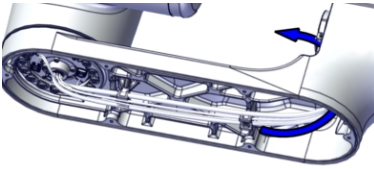
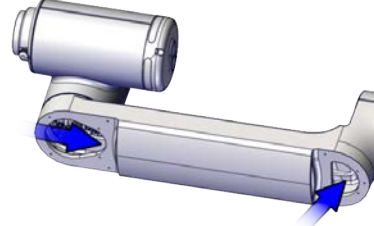
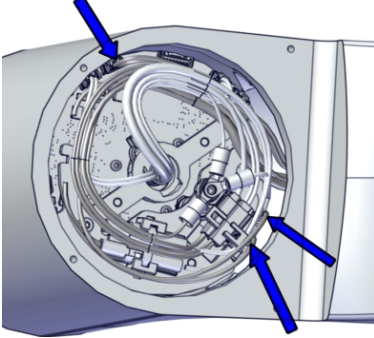
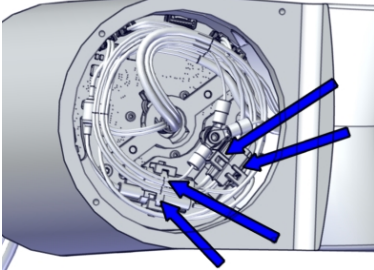
	Action	Note
1	Insert the cabling into the tubular.	<p>Valid for CRB 15000-5/0.95</p>  <p>xx2000002148</p> <p>Valid for CRB 15000-10/1.52 and CRB 15000-12/1.27</p>  <p>xx2300000845</p>
2	<p>Reconnect the connectors to the drive board.</p> <ul style="list-style-type: none"> • D3/4.X2 to X2 • D3/4.DC- to Ground • D3/4.DC+ to +DC 	 <p>xx2000002125</p>
3	<p>Connect the connectors to each other and snap them to the cable holders.</p> <ul style="list-style-type: none"> • J4/5.DC+ to J5/6.DC+ • J4/5.DC- to J5/6.DC- • J4/5.CS to J5/6.CS • J4/5.CP to J5/6.CP 	 <p>xx2000002089</p>

Continues on next page

5.4.3 Replacing the tubular
Continued

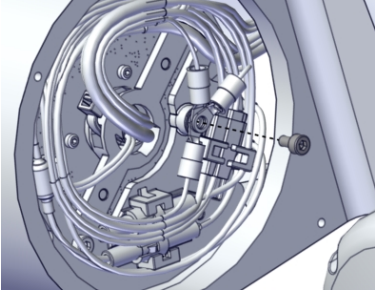
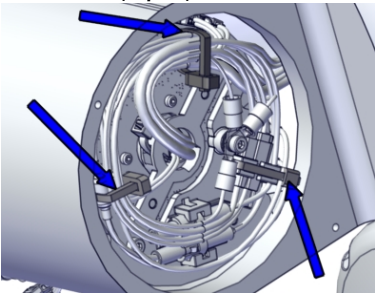
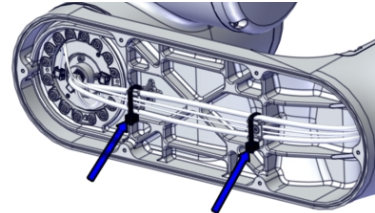
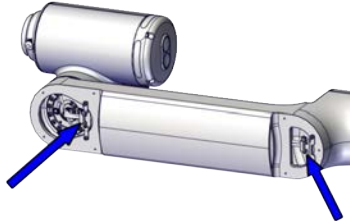
	Action	Note
4	Secure the cables for functional earth and protective earth with a screw.	<p>Hex socket head cap screw: M3x6 (1 pcs). Tightening torque: 0.8 Nm.</p>  <p>xx2000002087</p>
5	Secure the cabling to joint unit with cable ties.	<p>Cable ties (3 pcs)</p>  <p>xx2000002086</p>
6	Secure the cabling to tubular with cable ties.	<p>Cable ties (2 pcs) Valid for CRB 15000-5/0.95</p>  <p>xx2000002124</p> <p>Valid for CRB 15000-10/1.52 and CRB 15000-12/1.27</p>  <p>xx2300000842</p>

Continues on next page

5 Repair

5.4.3 Replacing the tubular

Continued

Refitting the tubular cover (-5/0.95)

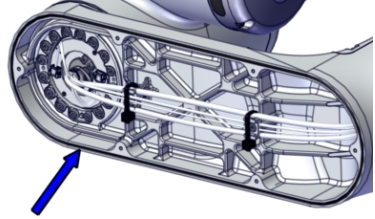
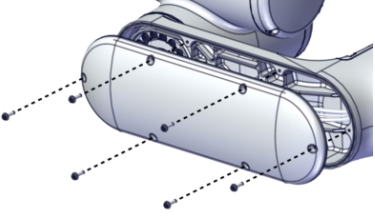
	Action	Note
1	Wipe, lubricate and fit the o-ring to its groove. Replace if damaged.	O-ring: 3HAC061327-043 Grease: 3HAC042536-001 (Shell Gadus S2)  xx2000002149
2	Refit the cover with new attachment screws.	Flange socket head screw with glue: 3HAB3413-312 M3x12 12.9 Lafre 2C2B/FC6.9+PrO-COat111, with NYPLAS glue For tubular cover of CRB 15000-5/0.95. Always use new screws. If ordering a new axis-4 or axis-5 joint unit spare part, new screws for the tubular cover are included. Tightening torque: 1.6 Nm.  xx2000002123

Continues on next page

Refitting the tubular cover (-10/1.52 and -12/1.27)

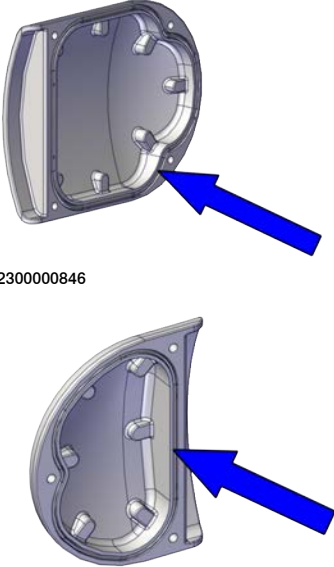
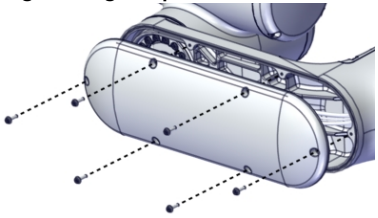
	Action	Note
1	Wipe, lubricate and fit the o-ring to its groove. Replace if damaged.	<p>O-ring: 3HAC061327-076 O-ring: 3HAB3772-166 Grease: 3HAC042536-001 (Shell Gadus S2)</p>  <p>xx2300000846</p> <p>xx2300000847</p>
2	Refit the covers with new attachment screws.	<p>Hex socket head cap screw: 3HAB3409-224 M3x12 12.9 Lafre 2C2B/FC6.9 (3 pcs) Tightening torque: 1.4 Nm.</p>  <p>xx2000002123</p>

Continues on next page

5 Repair

5.4.3 Replacing the tubular

Continued

Refitting the axis-4 cover

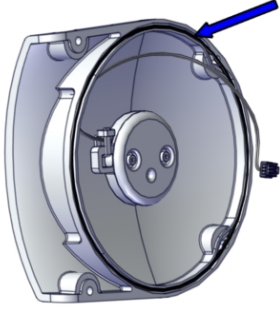
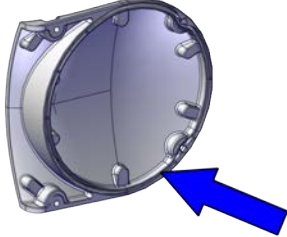
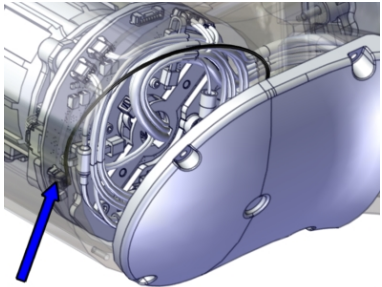
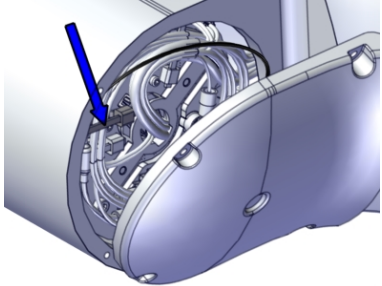
	Action	Note
1	Fit the o-ring to its groove. Replace if damaged.	<p>Valid for CRB 15000-5/0.95 O-ring: 3HAC061327-051</p>  <p>xx200002092</p> <p>Valid for CRB 15000-10/1.52 and CRB 15000-12/1.27 O-ring: 3HAC061327-051</p>  <p>xx2300000848</p>
2	For robots with RobotWare earlier than 7.10 Place the cover at mounting position and reconnect the brake release connector DR.X8 to the drive board.	<p>Tweezers</p>  <p>xx200002085</p>
3	For robots with RobotWare earlier than 7.10 Secure the brake release cable with a cable tie.	<p>Cable ties</p>  <p>xx200002084</p>

Continues on next page

5.4.3 Replacing the tubular
Continued

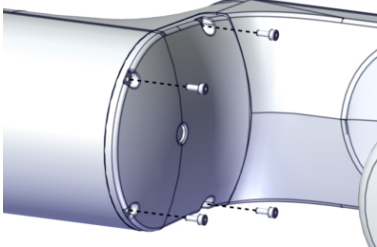
	Action	Note
4	Refit the cover with the four screws.	<p>Hex socket head cap screw: M3x8 12.9 Lafre 2C2B/FC6.9 (4 pcs) Tightening torque: 0.2 Nm (for CRB 15000-5/0.95) / 0.9 Nm (for CRB 15000-10/1.52 and CRB 15000-12/1.27) Tightening torque: 0.9 Nm</p>  <p>xx2000002083</p>

Refitting the tubular

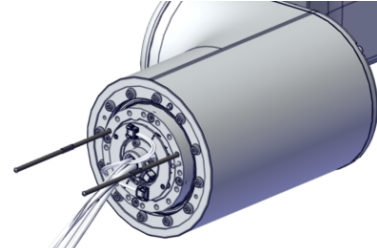
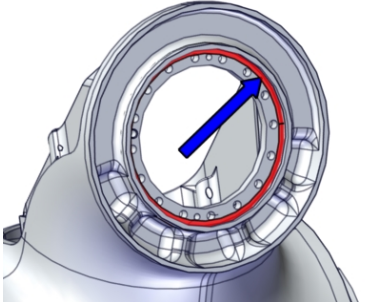
	Action	Note
1	Fit two guide pins to the axis-4 joint.	<p>Guide pin, M3x110: 3HAC077787-001 Always use guide pins in pairs.</p>  <p>xx2000002093</p>
2	Clean the mounting surface with isopropanol. Apply flange sealant to the corner of the housing mounting surface, as pointed out in the figure.	<p>Cleaning agent: Isopropanol Flange sealant: Loctite 574</p>  <p>xx2000002094</p>

Continues on next page

5 Repair

5.4.3 Replacing the tubular

Continued

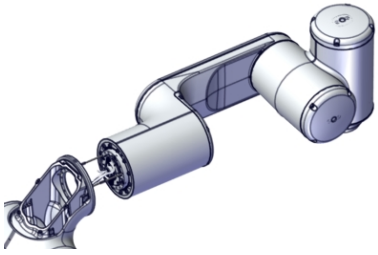
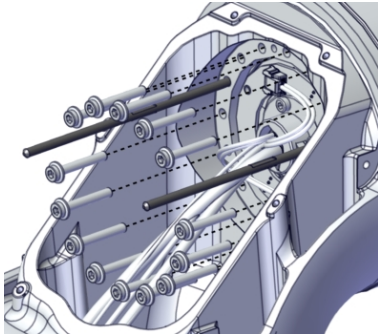
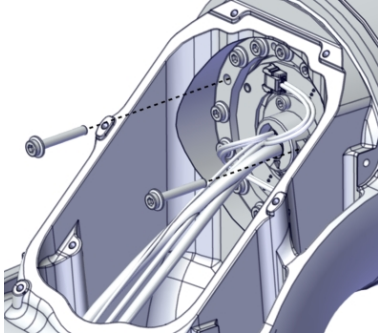
	Action	Note
3	Lift the tubular into mounting position while inserting the cabling into the housing.	 xx2000002082
4	Slide the tubular into place on the guide pins.	
5	Secure the tubular to the housing with all attachment screws but two. Pre-tighten the screws crosswise firstly.	Flange socket head screw: M3x20 12.9 Lafre 2C2B/FC6.9+PrO- COat111  xx2000002081
6	Remove the guide pins and fasten the remaining two screws.	Flange socket head screw: M3x20 12.9 Lafre 2C2B/FC6.9+PrO- COat111  xx2000002079
7	Torque tighten all screws crosswise.	Tightening torque: 1.8 Nm.

Continues on next page

5.4.3 Replacing the tubular
Continued

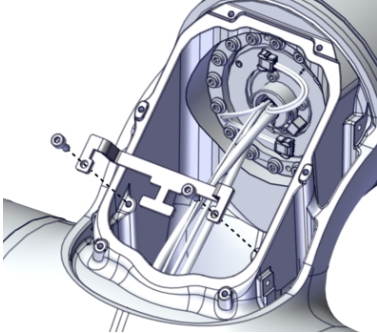
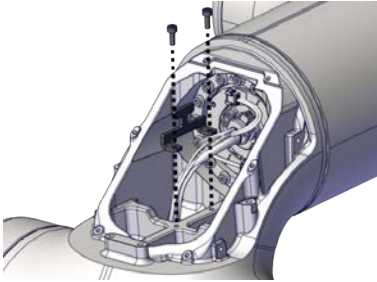
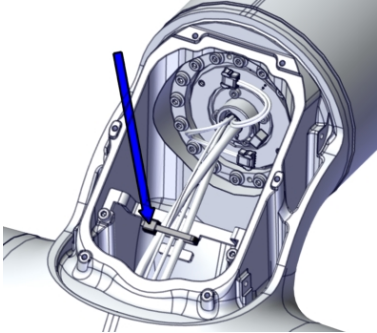
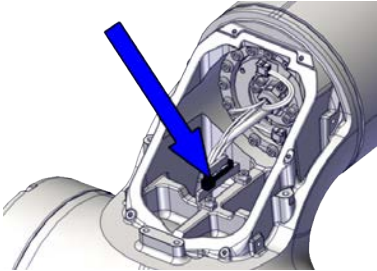
	Action	Note
8	Refit the cable bracket with the two screws.	<p>Hex socket head cap screw: M3x8 12.9 Lafre 2C2B/FC6.9 (4 pcs). Tightening torque: 0.8 Nm Valid for CRB 15000-5/0.95</p>  <p>xx2000002078</p> <p>Valid for CRB 15000-10/1.52 and CRB 15000-12/1.27</p>  <p>xx2300000840</p>
9	Secure the cabling with a cable tie.	<p>Cable ties (1 pcs) Valid for CRB 15000-5/0.95</p>  <p>xx2000002077</p> <p>Valid for CRB 15000-10/1.52 and CRB 15000-12/1.27</p>  <p>xx2300000839</p>

Continues on next page

5 Repair

5.4.3 Replacing the tubular

Continued

Closing the housing top cover

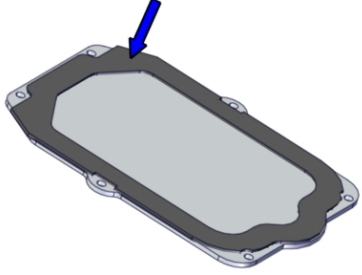
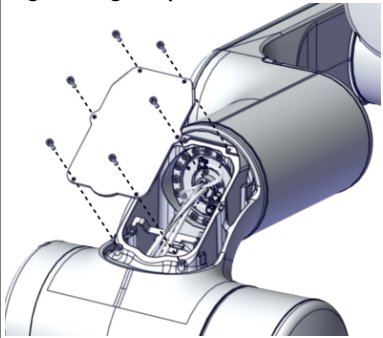
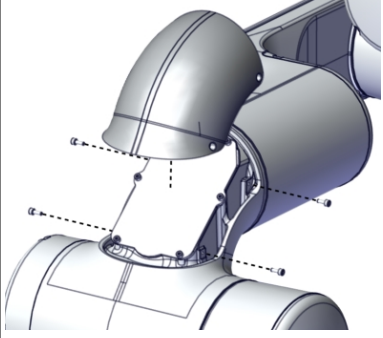
	Action	Note
1	Check the inner plate gasket. Replace if damaged.	Gasket: 3HAC075056-001  xx2000002095
2	Refit the inner plate with the screws.	Hex socket head cap screw: M3x8 12.9 Lafre 2C2B/FC6.9 (4 pcs). Tightening torque: 1.4 Nm  xx2000002076
3	Refit the cover with the four screws.	Hex socket head cap screw: M3x8 12.9 Lafre 2C2B/FC6.9 (4 pcs). Tightening torque: 0.45 Nm  xx2000002075

Continues on next page

Connecting the tubular cabling

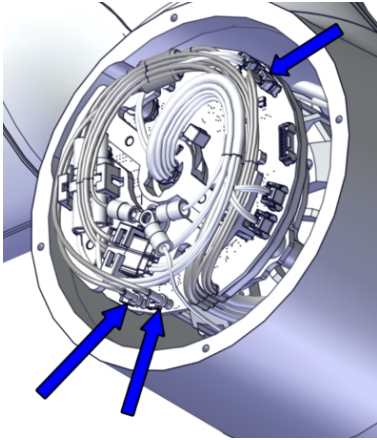
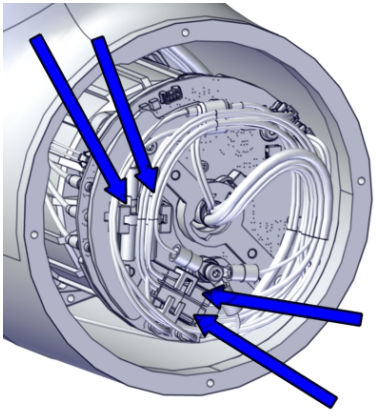
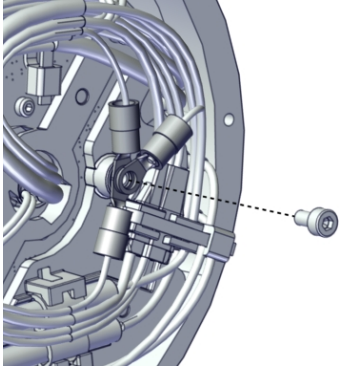
	Action	Note
1	Reconnect the connectors to the drive board. <ul style="list-style-type: none"> • D3/4.DC+ to DC+ • D3/4.DC- to Ground • D3/4.X2 to X2 	 <p>xx2000002120</p>
2	Connect the connectors to each other and snap them to the cable holders. <ul style="list-style-type: none"> • J3.DC+ to J3.DC+ • J3.DC- to J3.DC- • J3.CS to J3.CS • J3.CP to J3.CP 	 <p>xx2000002067</p>
3	Secure the cables for functional earth and protective earth with a screw.	Hex socket head cap screw: M3x6 (1 pcs). Tightening torque: 0.8 Nm.  <p>xx2000001945</p>

Continues on next page

5 Repair

5.4.3 Replacing the tubular

Continued

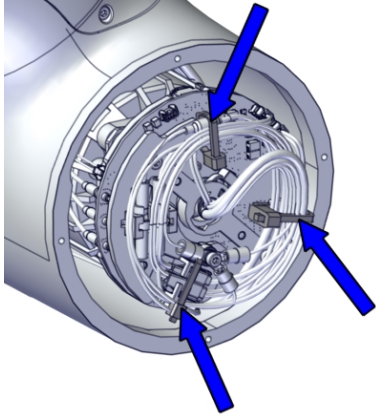
	Action	Note
4	Secure the cabling with cable ties.	Cable ties (3 pcs)  xx2000002066

Refitting the housing cover (-5/0.95)

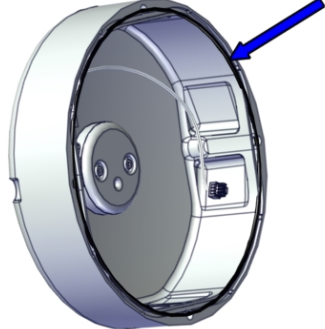
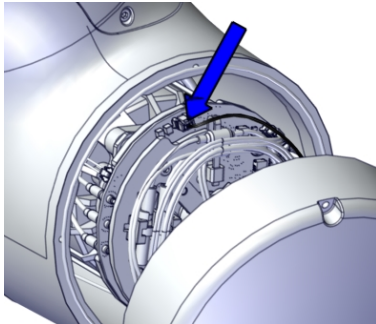
	Action	Note
1	Fit the o-ring to its groove. Replace if damaged.	O-ring: 3HAC061327-047  xx2000001962
2	For robots with RobotWare earlier than 7.10 Place the cover at mounting position and reconnect the brake release connector DR.X8 to the drive board. Orient the cover for proper arrangement of the brake release cable.	 xx2000002023

Continues on next page

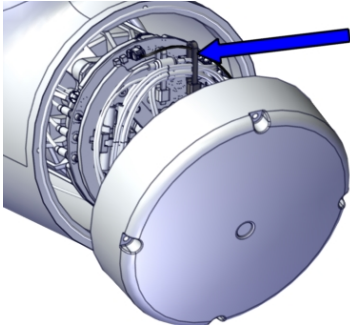
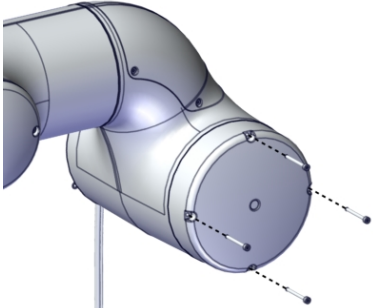
	Action	Note
3	<p>For robots with RobotWare earlier than 7.10 Secure the brake release cable with a cable tie.</p>	<p>Cable ties</p>  <p>xx2000002022</p>
4	<p>Refit the cover with the four screws.</p>	<p>Hex socket head cap screw: M3x30 12.9 Lafre 2C2B/FC6.9 (4 pcs) Tightening torque: 0.45 Nm</p>  <p>xx2000002021</p>

Refitting the housing cover and insert (-10/1.52 and -12/1.27)

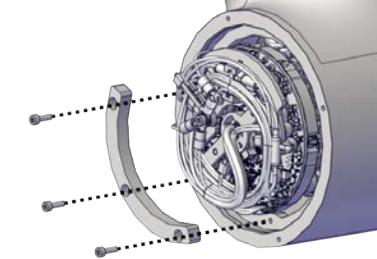
	Action	Note
1	<p>Refit the insert.</p>	<p>Insert: 3HAC084002-001 Hex socket head cap screw: M3x10 12.9 Lafre 2C2B/FC6.9 (3 pcs) Tightening torque: 1.4 Nm</p>  <p>xx2300000834</p>

Continues on next page

5 Repair

5.4.3 Replacing the tubular

Continued

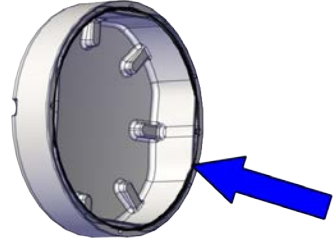
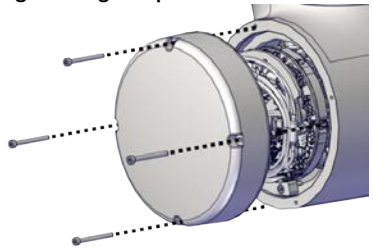
	Action	Note
2	Fit the o-ring to its groove. Replace if damaged.	O-ring: 3HAC061327-047  xx2300000835
3	Refit the cover with the four screws.	Hex socket head cap screw: M3x30 12.9 Lafre 2C2B/FC6.9 (4 pcs) Tightening torque: 1.4 Nm  xx2300000833

Concluding procedure

	Action	Note
1	Calibrate the axis-4 joint unit torque sensor.	See Calibration on page 1063
2	 DANGER Make sure all safety requirements are met when performing the first test run. See Test run after installation, maintenance, or repair on page 90 .	

5.4.4 Replacing the wrist housing

Location of the wrist

The wrist is located as shown in the figure.

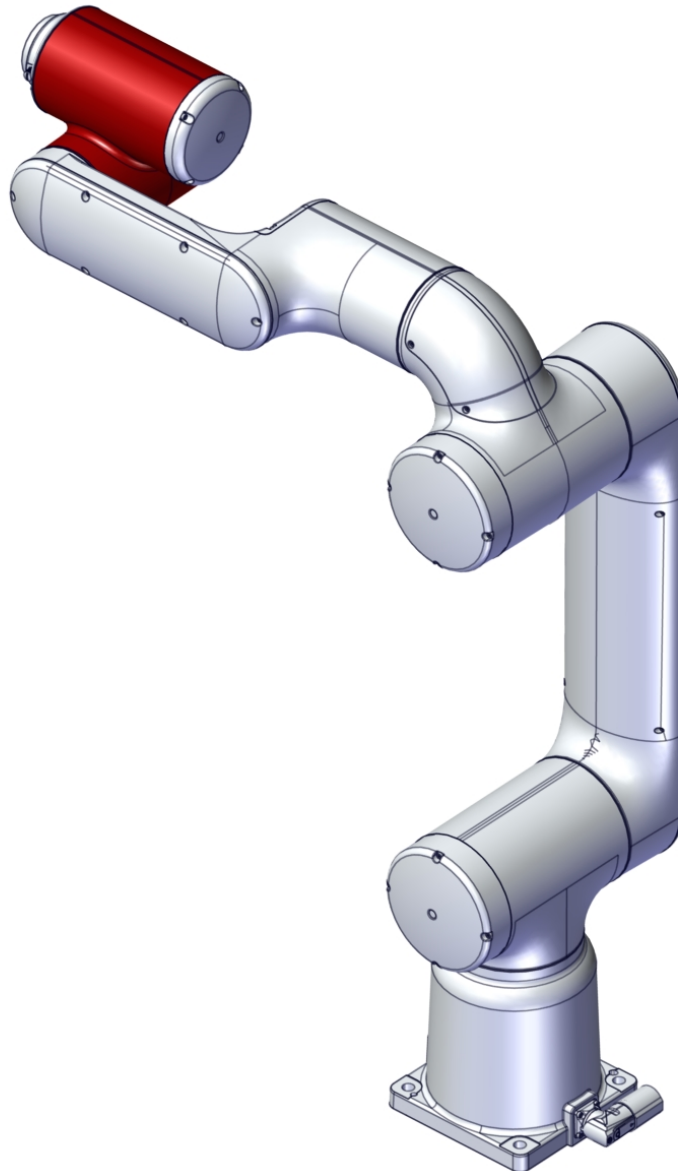

xx210000053

Summary of the replacement procedure

This is a brief summary of the replacement procedure, containing the major actions to be performed.

- 1 Remove the tubular cover.
- 2 Separate the cabling between the tubular and the tilt (at the axis-4 joint unit).
- 3 Remove the tilt and place on a workbench.
- 4 Remove the axis-6 joint unit.

Continues on next page

5 Repair

5.4.4 Replacing the wrist housing

Continued

- 5 Remove the axis-5 joint unit.
- 6 Replace the wrist housing.

Required spare parts

 **Note**

The spare part numbers that are listed in the table can be out of date. See the latest spare parts of the CRB 15000 via myABB Business Portal, www.abb.com/myABB.

Spare part	Article number	Note
Wrist housing	3HAC073951-001	Also order new attachment screws for the axis-5 and axis-6 joint unit: 3HAB3413-330 (24 pcs).
Flange socket head screw with glue	3HAB3413-330	M3x30 12.9 Lafre 2C2B/FC6.9+PrO-COat111, with NYPLAS glue , 12 pcs Used for joint unit of CRB 15000-5/0.95. Always use new screws when re-fitting a joint unit. If ordering a new joint unit spare part, new screws are included.
Flange socket head screw with glue	3HAB3413-330	M3x30 12.9 Lafre 2C2B/FC6.9+PrO-COat111, with NYPLAS glue , 12 pcs Used for joint unit of CRB 15000-5/0.95. Always use new screws when re-fitting a joint unit. If ordering a new joint unit spare part, new screws are included.
Flange socket head screw with glue	3HAB3413-312	M3x12 12.9 Lafre 2C2B/FC6.9+PrO-COat111, with NYPLAS glue For tubular cover of CRB 15000-5/0.95. Always use new screws. If ordering a new axis-4 or axis-5 joint unit spare part, new screws for the tubular cover are included.
Cable tie	3HAC075545-001	For securing joint unit cable.
Cable tie	3HAC075545-001	For securing joint unit cable.

Required tools and equipment

Equipment	Article number	Note
Lifting aid	3HAC077789-001	For joint units on axes 4, 5 and 6. Attachment screws M3x12 (4 pcs) are enclosed.

Continues on next page

5.4.4 Replacing the wrist housing
Continued

Equipment	Article number	Note
Guide pin, M3x110	3HAC077787-001	Always use guide pins in pairs. For joint units on axes 4, 5 and 6.
Protection plate	3HAC077790-001	For protection of drive board during cabling installation on joint units of CRB 15000-5/0.95.
Cable tie gun EVO 7i	-	HellermannTyton 110-77001 or similar
Tweezers	-	Used to handle drive board connectors.
Standard toolkit	-	Content is defined in section Standard toolkit on page 1099 .

Required consumables

Consumable	Article number	Note
Cleaning agent	-	Isopropanol
Flange sealant	-	Loctite 574
Grease	3HAC042536-001	Shell Gadus S2
Cable ties	-	
O-ring	3HAC061327-051	Axis-5 cover, used for CRB 15000-5/0.95. Replace if damaged.
O-ring	3HAC061327-051	Axis-5 cover, used for CRB 15000-10/1.52 and CRB 15000-12/1.27. Replace if damaged.
O-ring	3HAC061327-051	Arm-side interface Replace if damaged.
O-ring	3HAC061327-043	Tubular cover, used for CRB 15000-5/0.95. Replace if damaged.
O-ring	3HAB3772-166	Tubular cover, upper, used for CRB 15000-10/1.52 and CRB 15000-12/1.27. Replace if damaged.
O-ring	3HAC061327-076	Tubular cover, lower, used for CRB 15000-10/1.52 and CRB 15000-12/1.27. Replace if damaged.

Removing the wrist housing

Use these procedures to remove the wrist.

Preparations before removing the wrist

	Action	Note
1	Jog the robot to the synchronization position.	

Continues on next page

5 Repair

5.4.4 Replacing the wrist housing



Continued

	Action	Note
2	 CAUTION Turn off all supplies for electrical power to the robot, before starting the repair work.	

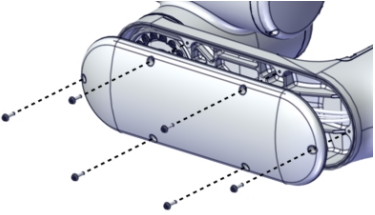
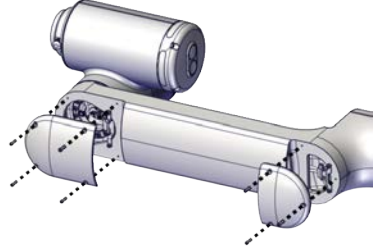
Removing the tubular cover

	Action	Note
1	Valid for CRB 15000-5/0.95 Remove the cover by removing the six screws. Dispose the screws. New screws must be used when refitting the cover. New screws are included in the spare part delivery of the joint unit.	 xx2000002123
2	Valid for CRB 15000-10/1.52 and CRB 15000-12/1.27 Remove the covers by removing the screws.	 xx2300000841

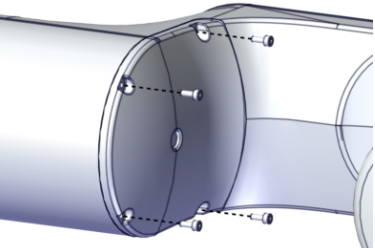
Removing the axis-4 cover

	Action	Note
1	Remove the cover screws.	 xx2000002083
2	 CAUTION Valid for CRB 15000-5/0.95 There is cabling connected between the cover and the joint unit drive board. Open the cover with care to avoid damage to the cabling or the connector(s). Do not leave the cover in location without being secured with the attachment screws.	

Continues on next page

5.4.4 Replacing the wrist housing
Continued

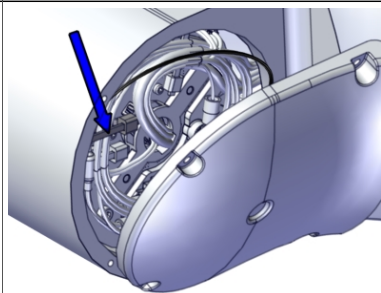
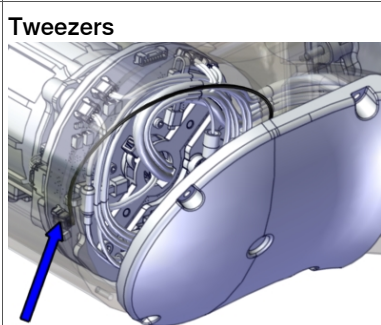
	Action	Note
3	<p>For robots with RobotWare earlier than 7.10 Open the cover and cut the cable tie that holds the brake release cable.</p>	 <p>xx200002084</p>
4	<p>For robots with RobotWare earlier than 7.10 Disconnect the brake release connector DR.X8 from the drive board. Remove the cover.</p>	<p>Tweezers</p>  <p>xx200002085</p>

Separating the cabling between the tubular and the tilt

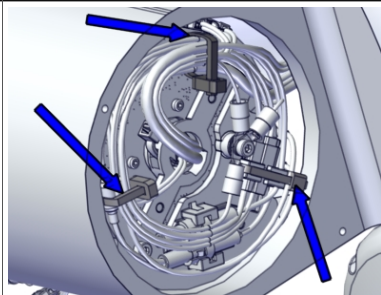
	Action	Note
1	<p>Cut the cable ties on joint unit.</p>	 <p>xx200002086</p>

Continues on next page

5 Repair

5.4.4 Replacing the wrist housing

Continued

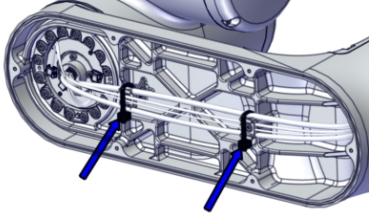
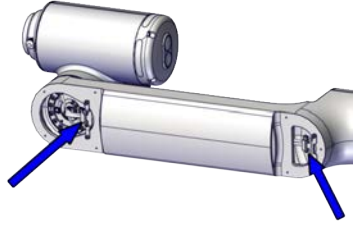
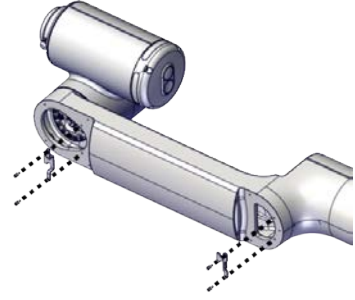
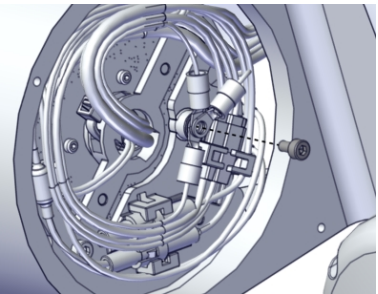
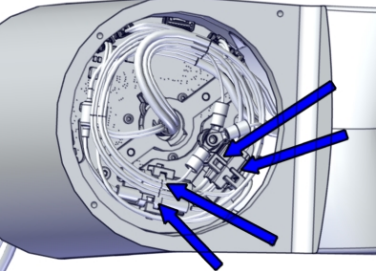
	Action	Note
2	Cut the cable ties on tubular, if needed.	<p>Valid for CRB 15000-5/0.95</p>  <p>xx2000002124</p> <p>Valid for CRB 15000-10/1.52 and CRB 15000-12/1.27</p>  <p>xx2300000842</p>
3	<p>Valid for CRB 15000-10/1.52 and CRB 15000-12/1.27</p> <p>Remove the cable brackets.</p>	 <p>xx2300000843</p>
4	Remove the functional and protective earth cables by removing the screw.	 <p>xx2000002087</p>
5	<p>Snap loose and disconnect the connectors:</p> <ul style="list-style-type: none"> • J4/5.DC+ • J4/5.DC- • J4/5.CS • J4/5.CP 	 <p>xx2000002089</p>

Continues on next page

5.4.4 Replacing the wrist housing
Continued

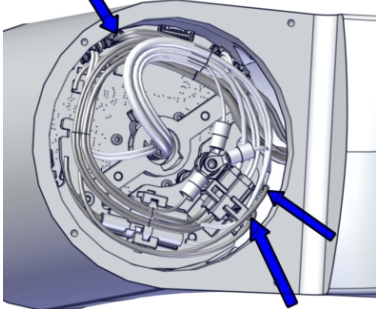
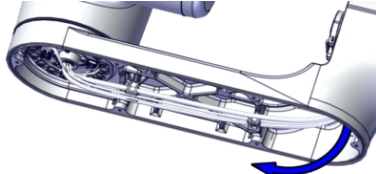
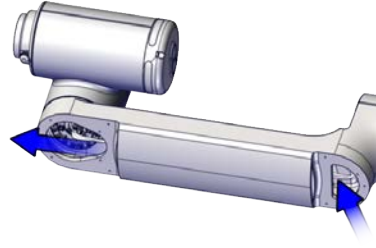
	Action	Note
6	<p>Disconnect the connectors that belongs to the axis-5 cabling, from the axis-4 drive board:</p> <ul style="list-style-type: none"> • D3/4.X2 • D3/4.DC- • D3/4.DC+ <p>Use tweezers, if needed.</p>	<p>Tweezers</p>  <p>xx2000002125</p>
7	<p>Pull out the cabling carefully from the tubular.</p>	<p>Valid for CRB 15000-5/0.95</p>  <p>xx2000002126</p> <p>Valid for CRB 15000-10/1.52 and CRB 15000-12/1.27</p>  <p>xx2300000844</p>

Continues on next page

5 Repair

5.4.4 Replacing the wrist housing

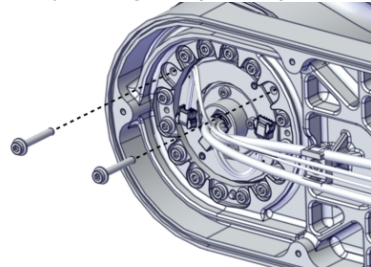
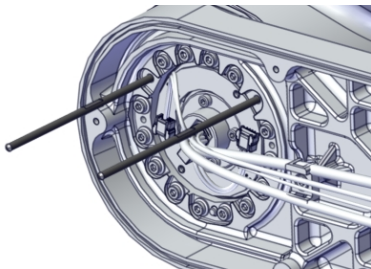
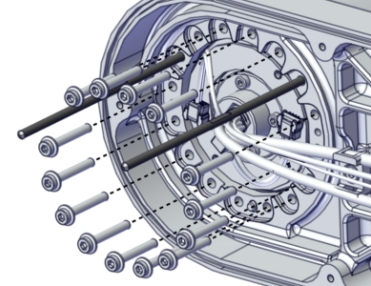
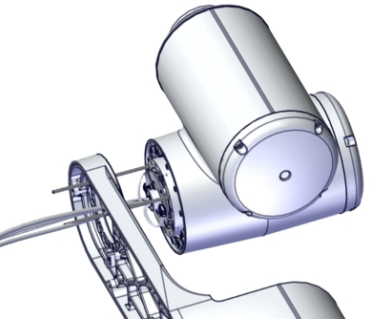

Continued

Removing the tilt

	Action	Note
1	Remove two attachment screws and fit two guide pins to the axis-5 joint unit.	<p>Guide pin, M3x110: 3HAC077787-001</p> <p>Always use guide pins in pairs.</p>  <p>xx2000002128</p>  <p>xx2000002129</p>
2	Remove the remaining attachment screws.	 <p>xx2000002130</p>
3	Press the tilt out of position using two of the previous attachment screws as removal tools.	
4	Remove the tilt from the tubular. Assist the cabling to be removed while lifting away the complete tilt. Place the tilt on a workbench.	 <p>xx2000002131</p>

Continues on next page

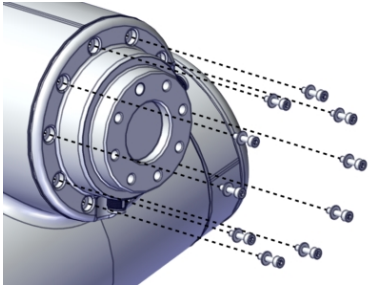
Removing the tool flange

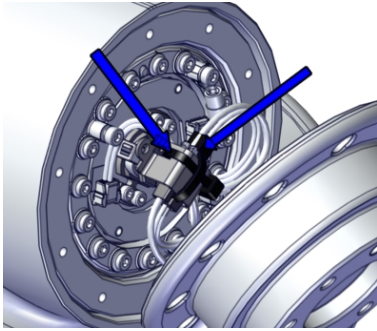
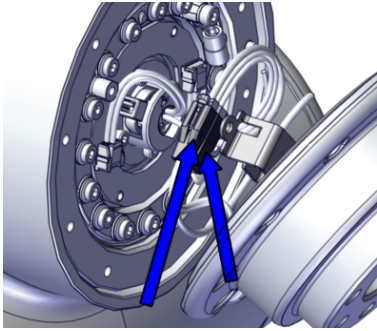
	Action	Note
1	Remove the tool flange screws and washers.	 <p>xx2000002155</p>
2	<p> CAUTION</p> <p>Valid for CRB 15000-5/0.95</p> <p>There is cabling connected between the cover and the joint unit drive board.</p> <p>Open the cover with care to avoid damage to the cabling or the connector(s).</p> <p>Do not leave the cover in location without being secured with the attachment screws.</p>	
3	Cut the cable ties.	 <p>xx2000002157</p>
4	Disconnect the CP/CS connectors from the drive board and remove the tool flange.	 <p>xx2000002158</p>

Continues on next page

5 Repair

5.4.4 Replacing the wrist housing

Continued

Disconnecting the tool flange functional earth cable

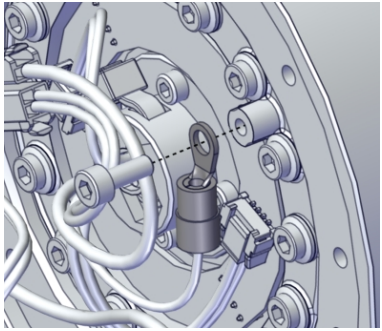

	Action	Note
1	Remove the functional earth cable by removing the screw.	 xx2000002159

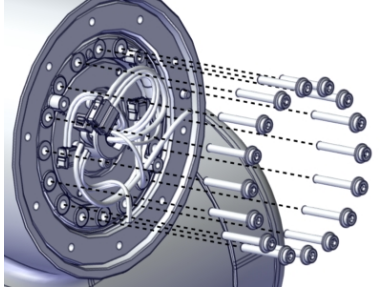
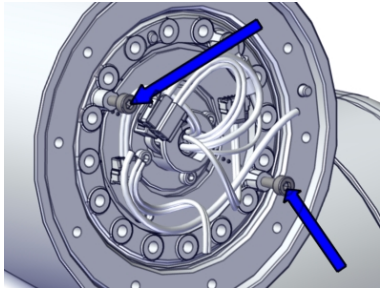
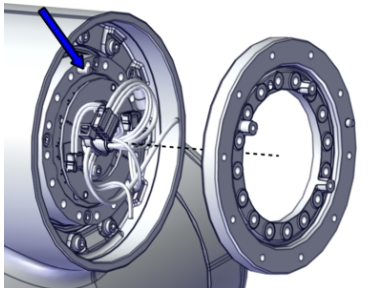
Removing the tool flange adapter

	Action	Note
1	Remove the tool flange adapter screws.	 xx2000002165
2	Press the adapter out of position by using two of the attachment screws as removal tools.	 xx2000002166
3	Remove the tool flange adapter.	 xx2000002167

Continues on next page

Removing the arm-side interface

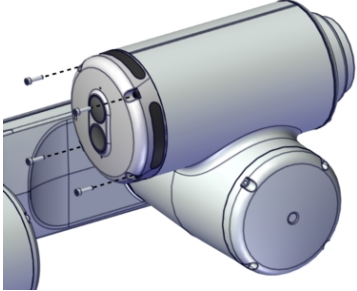
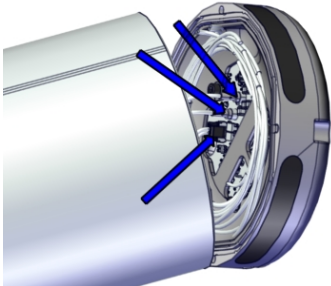
	Action	Note
1	 CAUTION Make sure that all supplies for electrical power are turned off.	
2	 CAUTION There is cabling connected between the arm-side interface and the joint unit drive board. Open the arm-side interface with care to avoid damage to the cabling or the connector(s). Do not leave the arm-side interface in location without being secured with the attachment screws.	
3	Remove the attachment screws.	 xx2000002550
4	Loosen the arm-side interface carefully and disconnect the connectors from it. <ul style="list-style-type: none"> • ASI.DC+ • ASI.DC- • ASI.X1 	 xx2100000335

Disconnecting the axis-6 joint unit cabling

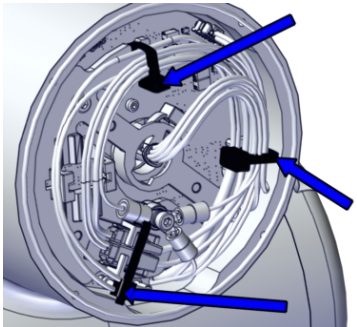

	Action	Note
1	Cut the cable ties.	 xx2000002161

Continues on next page

5 Repair

5.4.4 Replacing the wrist housing

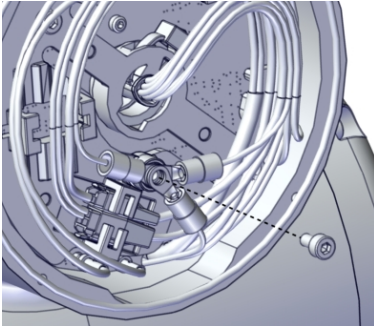
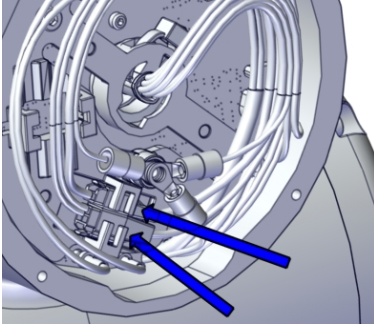
Continued

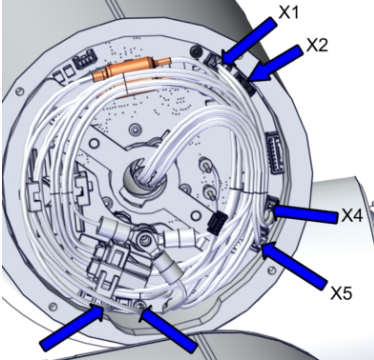
	Action	Note
2	Remove the functional and protective earth cables by removing the screw.	 xx2000002162
3	Snap loose and disconnect the connectors: <ul style="list-style-type: none">• J7.CS• J7.CP	 xx2000002163
4	Disconnect the connectors from the drive board. <ul style="list-style-type: none">• D6.X1• D6.DC+• D6.DC-• D6.X4• D6.X2• D6.X5 <p> CAUTION</p> Use tweezers to unlock connectors and pull them off.	Tweezers  xx2000002164

Continues on next page

Removing the axis-6 joint unit

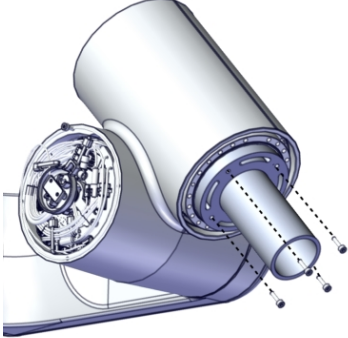
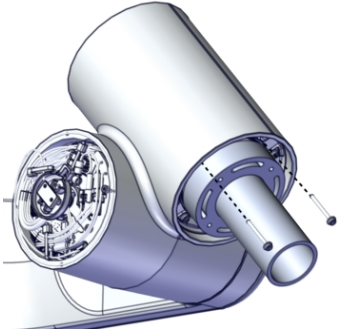
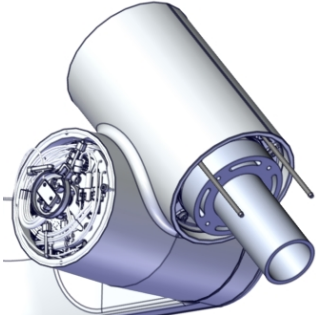

	Action	Note
1	<p>Fit the lifting aid to the joint unit, on the torque sensor side.</p> <p> CAUTION</p> <p>The connectors and the joint unit cables are sensitive to mechanical damage. Handle the assembly with care.</p>	<p>Lifting aid: 3HAC077789-001 Screws: M3x12 (4 pcs)</p>  <p>xx2000002168</p> <p>Position shown in the figure shows axis 5 jogged to +20°, which is a more convenient position when replacing only the axis-6 joint unit.</p>
2	<p>Remove two attachment screws. Dispose the screws. New screws are included in the spare part delivery of the joint unit.</p>	 <p>xx2000002170</p> <p>Position shown in the figure shows axis 5 jogged to +20°, which is a more convenient position when replacing only the axis-6 joint unit.</p>
3	<p>Fit two guide pins to the axis-6 joint unit.</p>	<p>Guide pin, M3x110: 3HAC077787-001 Always use guide pins in pairs. For joint units on axes 4, 5 and 6.</p>  <p>xx2100000328</p>

Continues on next page

5 Repair

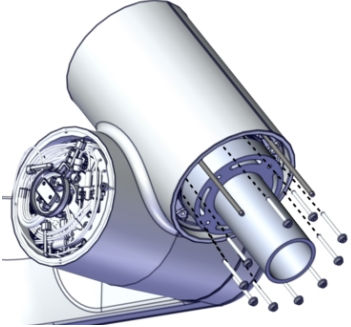
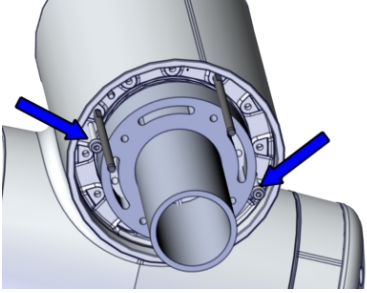

5.4.4 Replacing the wrist housing

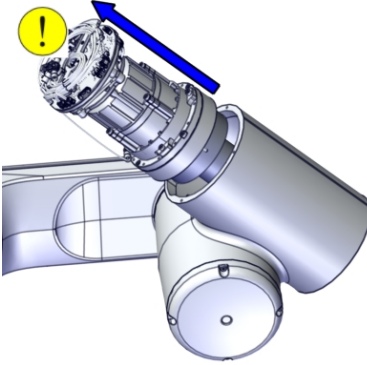
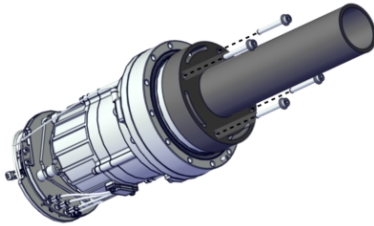
Continued

	Action	Note
4	<p>Remove the remaining attachment screws. Use two screws as press out screws in the upcoming step, then dispose all screws. New screws are included in the spare part delivery of the joint unit.</p>	 <p>xx2100000329</p>
5	<p>Press the joint unit out of position using two of the previous attachment screws as removal tools.</p>	 <p>xx2100000330</p>
6	<p>Remove the joint unit from the tubular.</p> <p> CAUTION</p> <p>The connectors and the joint unit cables are sensitive to mechanical damage. Handle the assembly with care.</p>	 <p>xx2000002169</p> <p>Position shown in the figure shows axis 5 jogged to +20°, which is a more convenient position when replacing only the axis-6 joint unit.</p>
7	<p>Remove the lifting aid and guide pins.</p>	 <p>xx2000001957</p>

Continues on next page

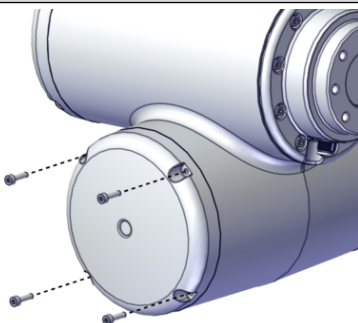
Removing the axis-5 cover

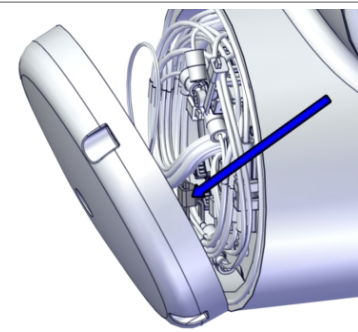
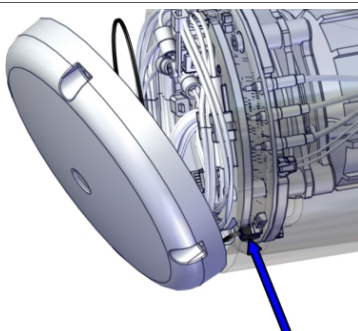
	Action	Note
1	Remove the cover by removing the four screws.	 <p>xx2000002132</p>
2	<p> CAUTION</p> <p>Valid for CRB 15000-5/0.95</p> <p>There is cabling connected between the cover and the joint unit drive board.</p> <p>Open the cover with care to avoid damage to the cabling or the connector(s).</p> <p>Do not leave the cover in location without being secured with the attachment screws.</p>	
3	<p>For robots with RobotWare earlier than 7.10</p> <p>Open the cover and cut the cable tie that holds the brake release cable.</p>	 <p>xx2000002133</p>
4	<p>For robots with RobotWare earlier than 7.10</p> <p>Disconnect the brake release connector DR.X8 from the drive board.</p> <p>Remove the cover.</p>	 <p>xx2000002134</p>



Continues on next page

5 Repair

5.4.4 Replacing the wrist housing

Continued

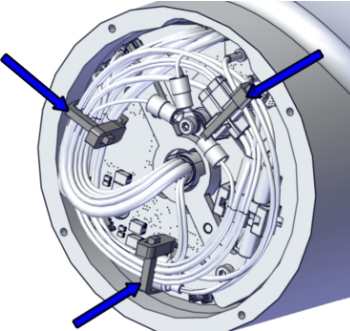
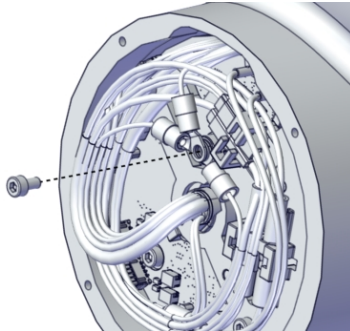
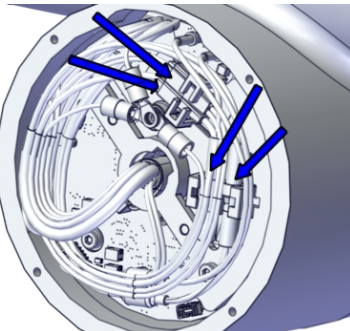
Disconnecting the axis-5 joint unit cabling

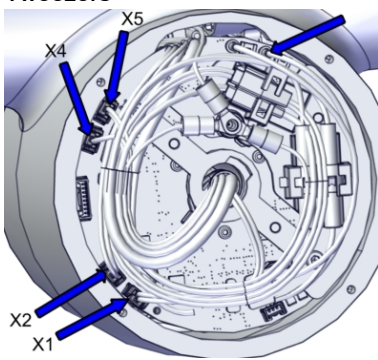
	Action	Note
1	Cut the cable ties.	 <p>xx2000002135</p>
2	Remove the functional and protective earth cables by removing the screw.	 <p>xx2000002136</p>
3	Snap loose and disconnect the connectors: <ul style="list-style-type: none"> • J5/6.DC+ • J5/6.DC- • J5/6.CS • J5/6.CP 	 <p>xx2000002137</p>
4	Disconnect the connectors from the drive board. <ul style="list-style-type: none"> • D4/5.X1 • D5.DC+ • D5.DC- • D4/5.X4 • D5.X2 • D4/5.X5 <p> CAUTION</p> <p>Use tweezers to unlock connectors and pull them off.</p>	<p>Tweezers</p>  <p>xx2000002138</p>

Continues on next page

Removing the axis-5 joint unit

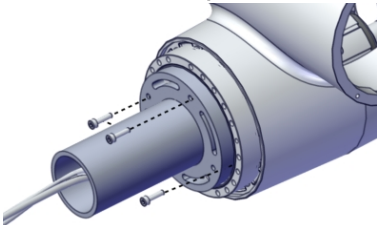
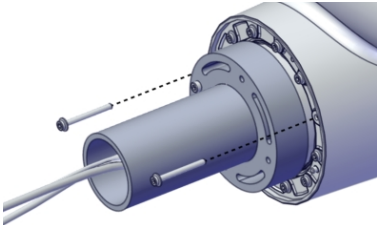
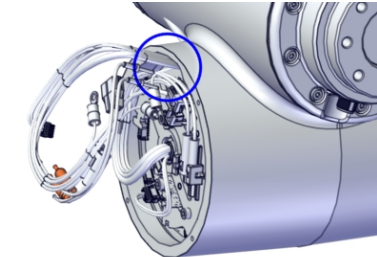
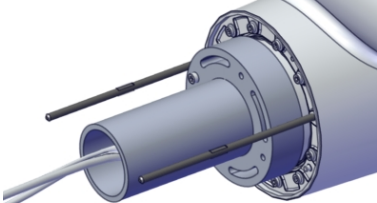
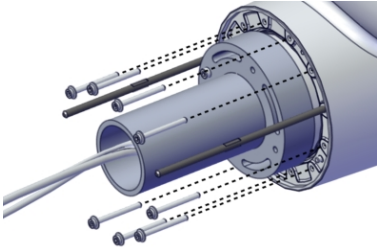

	Action	Note
1	<p>Fit the lifting aid to the joint unit, on the torque sensor side.</p> <p> CAUTION</p> <p>The connectors and the joint unit cables are sensitive to mechanical damage. Handle the assembly with care.</p>	<p>Lifting aid: 3HAC077789-001 Screws: M3x12 (4 pcs)</p>  <p>xx2000002139</p>
2	<p>Remove two attachment screws. Dispose the screws. New screws are included in the spare part delivery of the joint unit.</p>	 <p>xx2000002140</p>
3	<p>Put the cabling at the slot in order not to squeeze it during removal of joint unit.</p>	 <p>xx2100000284</p>
4	<p>Fit two guide pins to the axis-5 joint unit.</p>	<p>Guide pin, M3x110: 3HAC077787-001 Always use guide pins in pairs. For joint units on axes 4, 5 and 6.</p>  <p>xx2100000332</p>
5	<p>Remove the remaining attachment screws. Use two screws as press out screws in the upcoming step, then dispose all screws. New screws are included in the spare part delivery of the joint unit.</p>	 <p>xx2100000333</p>

Continues on next page

5 Repair

5.4.4 Replacing the wrist housing

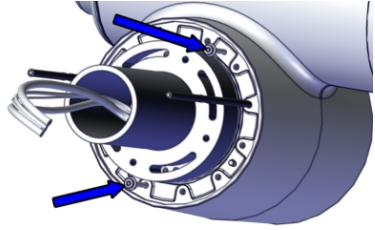
Continued

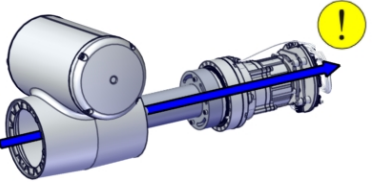
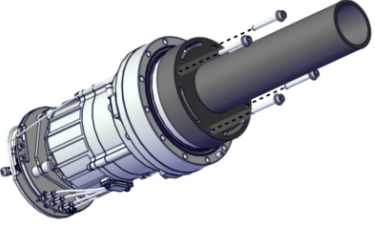
	Action	Note
6	Press the joint unit out of position using two of the previous attachment screws as removal tools.	 xx2100000334
7	Remove the joint unit from the tubular.  CAUTION The connectors and the joint unit cables are sensitive to mechanical damage. Handle the assembly with care.	 xx2000002141
8	Remove the lifting aid and guide pins.	 xx2000001957

Replacing the wrist

	Action	Note
1	Replace the writ unit.	Wrist housing: 3HAC073951-001 (for CRB 15000-5/0.95) / 3HAC073951-001 (for CRB 15000-10/1.52 and CRB 15000-12/1.27)

Refitting the wrist housing



Use these procedures to refit the wrist.

Preparations before fitting the joint unit



	Action	Note
1	 ELECTROSTATIC DISCHARGE (ESD) The unit is sensitive to ESD. Before handling the unit read the safety information in section The unit is sensitive to ESD on page 53 .	

Continues on next page

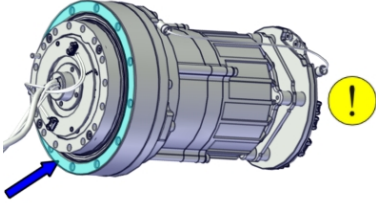
5.4.4 Replacing the wrist housing
Continued

	Action	Note
2	Clean the mounting surface of the joint unit and the mating surface on the casting with isopropanol. Joint unit mounting surface is pointed out in the figure.	Cleaning agent: Isopropanol Flange sealant: Loctite 574
3	Apply a thin layer of flange sealant to the mounting surface. Do not contaminate the radial sealing with sealant.  CAUTION The connectors and the joint unit cables are sensitive to mechanical damage. Handle the assembly with care.  ELECTROSTATIC DISCHARGE (ESD) The unit is sensitive to ESD. Before handling the unit read the safety information in section The unit is sensitive to ESD on page 53 .	 xx2000001860

Refitting the axis-5 joint unit and transition cabling

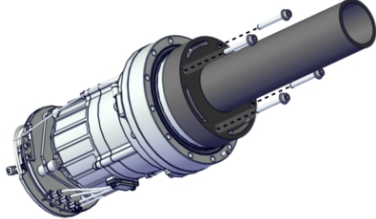
	Action	Note
1	 CAUTION Axis-5 joint unit used for CRB 15000-5/0.95 has the same appearance as that used for CRB 15000-10/1.52 and CRB 15000-12/1.27. Do not mix the joint units for different manipulator variants. Always check the mark or label on the joint units before refitting.	
2	Fit the lifting aid to the joint unit.  CAUTION The connectors and the joint unit cables are sensitive to mechanical damage. Handle the assembly with care.	Joint unit: 3HAC079143-001 (for CRB 15000-5/0.95) / 3HAC087546-001 (for CRB 15000-10/1.52 and CRB 15000-12/1.27) Lifting aid: 3HAC077789-001 Screws: M3x12 (4 pcs)  xx2000001957

Continues on next page



5 Repair

5.4.4 Replacing the wrist housing

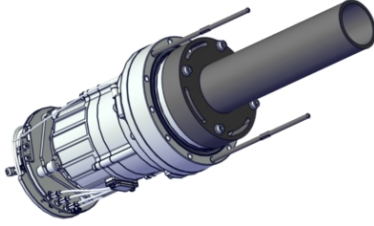
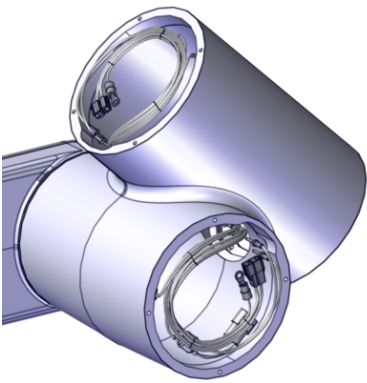
Continued

	Action	Note
3	Fit two guide pins to the joint unit.	<p>Guide pin, M3x110: 3HAC077787-001</p> <p>Always use guide pins in pairs.</p> <p>For joint units on axes 4, 5 and 6.</p>  <p>xx2000002438</p>
4	Fit the transition cable between axis-5 and axis-6 joint units into the tilt.	<p>Cable harness, transition joint-5 and joint-6: 3HAC083726-001</p>  <p>xx2100000040</p>

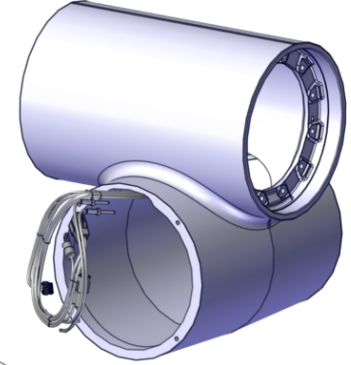
Continues on next page

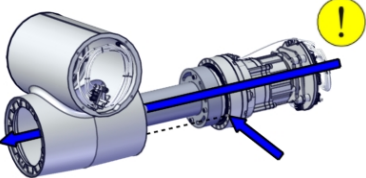
	Action	Note
5	Place the cabling at the slot before refitting the joint unit.	 <p>xx210000041</p>  <p>xx210000285</p>
6	<p>Fit the joint unit to the tilt, aligning the pin with the pin hole.</p> <p> CAUTION</p> <p>The connectors and the joint unit cables are sensitive to mechanical damage. Handle the assembly with care.</p>	 <p>xx2000002142</p>

Continues on next page

5 Repair

5.4.4 Replacing the wrist housing

Continued

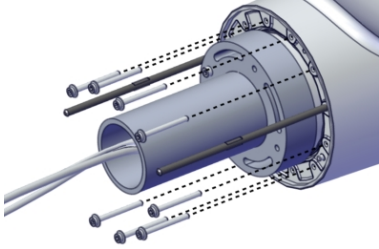
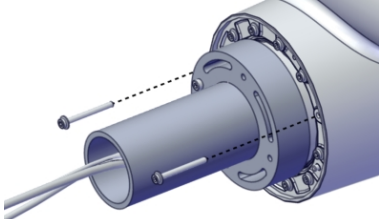
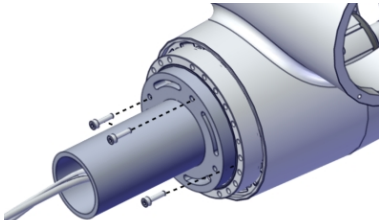
	Action	Note
7	Secure the joint unit with new attachment screws.	<p>Flange socket head screw with glue: 3HAB3413-330 M3x30 12.9 Lafre 2C2B/FC6.9+PrO-COat111, with NYPLAS glue , 12 pcs Used for joint unit of CRB 15000-5/0.95.</p> <p>Always use new screws when refitting a joint unit. If ordering a new joint unit spare part, new screws are included.</p>  <p>xx2100000333</p>
8	Remove the guide pins and secure the remaining two attachment screws.	 <p>xx2000002140</p>
9	Pre-tighten the screws crosswise.	
10	Torque tighten all screws crosswise.	<p>Tightening torque: 1.4 Nm (for CRB 15000-5/0.95) / 1.9 Nm (for CRB 15000-10/1.52 and CRB 15000-12/1.27)</p>
11	Remove the lifting aid by removing the screws.	 <p>xx2000002139</p>
12	Clean pushed-out flange sealant, if any.	

Continues on next page

Connecting the axis-5 joint unit cabling

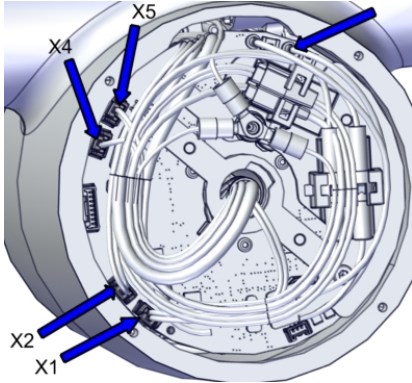
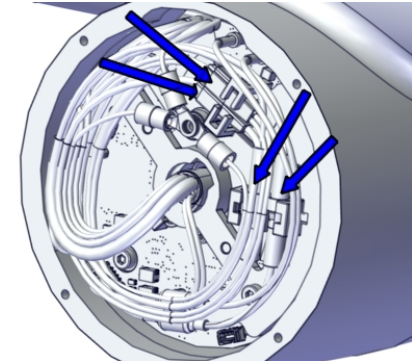
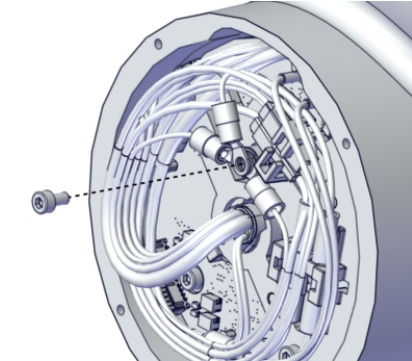
	Action	Note
1	<p>Reconnect the connectors to the drive board.</p> <ul style="list-style-type: none"> • D4/5.X1 to X1 • D5.DC+ to +DC • D5.DC- to Ground • D4/5.X4 to X4 • D5/4.X2 to X2 • D4/5.X5 to X5 	 <p>xx2000002138</p>
2	<p>Connect the connectors to each other and snap them to the cable holders.</p> <ul style="list-style-type: none"> • J5/6.DC+ to J6.DC+ • J5/6.DC- to J6.DC- • J5/6.CS to J6.CS • J5/6.CP to J6.CP 	 <p>xx2000002137</p>
3	<p>Secure the cables for functional earth and protective earth with a screw.</p>	<p>Hex socket head cap screw: M3x6 (1 pcs). Tightening torque: 0.8 Nm.</p>  <p>xx2000002136</p>

Continues on next page

5 Repair

5.4.4 Replacing the wrist housing

Continued

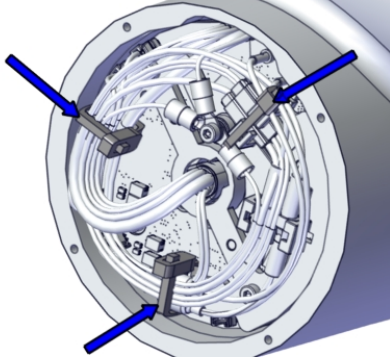
	Action	Note
4	Secure the cabling with cable ties.	Cable ties (3 pcs)  xx2000002135

Refitting the axis-5 cover

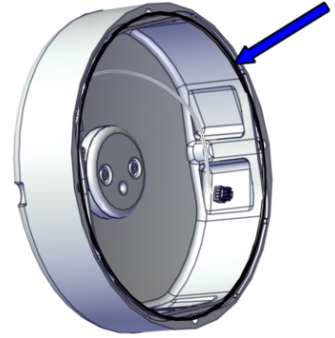
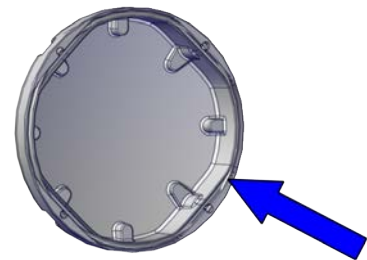
	Action	Note
1	Fit the o-ring to its groove. Replace if damaged.	Valid for CRB 15000-5/0.95 O-ring: 3HAC061327-051  xx2000001962 Valid for CRB 15000-10/1.52 and CRB 15000-12/1.27 O-ring: 3HAC061327-051  xx2300000849

Continues on next page

5.4.4 Replacing the wrist housing
Continued

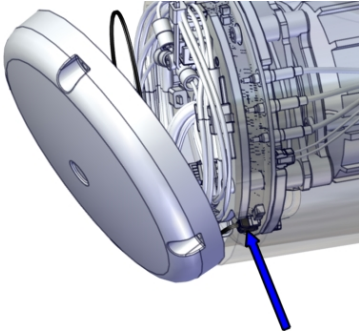
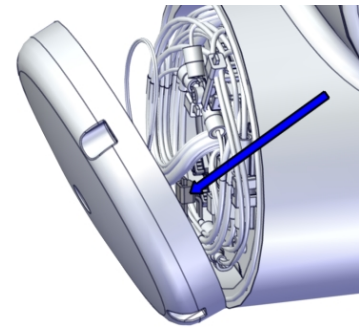
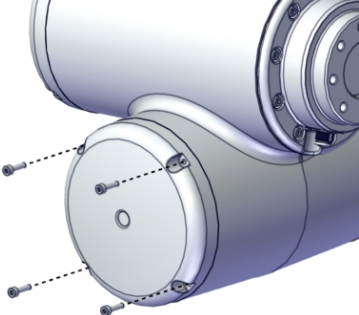
	Action	Note
2	<p>For robots with RobotWare earlier than 7.10 Place the cover at mounting position and reconnect the brake release connector DR.X8 to the drive board.</p>	 <p>xx2000002134</p>
3	<p>For robots with RobotWare earlier than 7.10 Secure the brake release cable with a cable tie.</p>	<p>Cable ties</p>  <p>xx2000002133</p>
4	<p>Refit the cover with the four screws.</p>	<p>Valid for CRB 15000-5/0.95 Hex socket head cap screw: M3x8 12.9 Lafre 2C2B/FC6.9 (4 pcs) Tightening torque: 0.2 Nm Valid for CRB 15000-10/1.52 and CRB 15000-12/1.27 Hex socket head cap screw: M3x12 12.9 Lafre 2C2B/FC6.9 (4 pcs) Tightening torque: 1.4 Nm</p>  <p>xx2000002132</p>



Continues on next page

5 Repair

5.4.4 Replacing the wrist housing

Continued

Preparations before fitting the joint unit

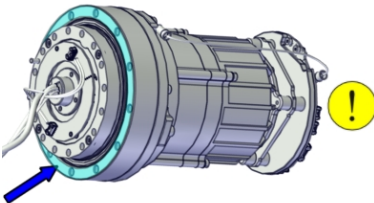

	Action	Note
1	 ELECTROSTATIC DISCHARGE (ESD) The unit is sensitive to ESD. Before handling the unit read the safety information in section <i>The unit is sensitive to ESD on page 53</i> .	
2	Clean the mounting surface of the joint unit and the mating surface on the casting with isopropanol. Joint unit mounting surface is pointed out in the figure.	Cleaning agent: Isopropanol Flange sealant: Loctite 574
3	Apply a thin layer of flange sealant to the mounting surface. Do not contaminate the radial sealing with sealant.  CAUTION The connectors and the joint unit cables are sensitive to mechanical damage. Handle the assembly with care.  ELECTROSTATIC DISCHARGE (ESD) The unit is sensitive to ESD. Before handling the unit read the safety information in section <i>The unit is sensitive to ESD on page 53</i> .	 xx2000001860

Refitting the axis-6 joint unit

	Action	Note
1	 CAUTION Axis-6 joint unit used for CRB 15000-5/0.95 has the same appearance as that used for CRB 15000-10/1.52 and CRB 15000-12/1.27. Do not mix the joint units for different manipulator variants. Always check the mark or label on the joint units before refitting.	

Continues on next page

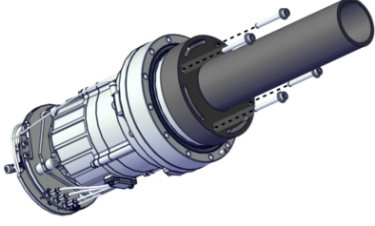
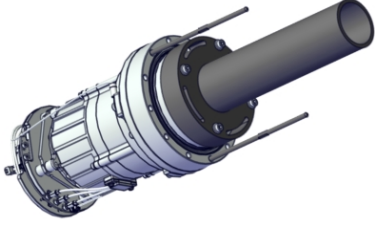
5.4.4 Replacing the wrist housing
Continued

	Action	Note
2	<p>Fit the lifting aid to the joint unit.</p> <p> CAUTION</p> <p>The connectors and the joint unit cables are sensitive to mechanical damage. Handle the assembly with care.</p>	<p>Joint unit: 3HAC079143-001 (for CRB 15000-5/0.95) / 3HAC087546-001 (for CRB 15000-10/1.52 and CRB 15000-12/1.27)</p> <p>Lifting aid: 3HAC077789-001</p> <p>Screws: M3x12 (4 pcs)</p>  <p>xx2000001957</p>
3	<p>Fit two guide pins to the joint unit.</p>	<p>Guide pin, M3x110: 3HAC077787-001</p> <p>Always use guide pins in pairs.</p> <p>For joint units on axes 4, 5 and 6.</p>  <p>xx2000002438</p>
4	<p>Place the cabling at the slot before refitting the joint unit.</p>	 <p>xx2100000041</p>

Continues on next page

5 Repair

5.4.4 Replacing the wrist housing

Continued

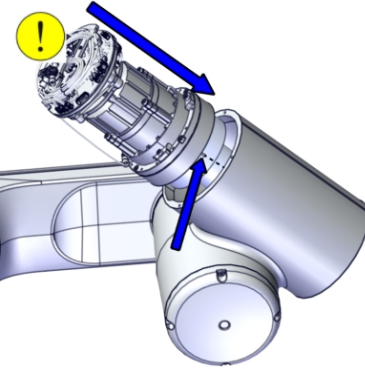
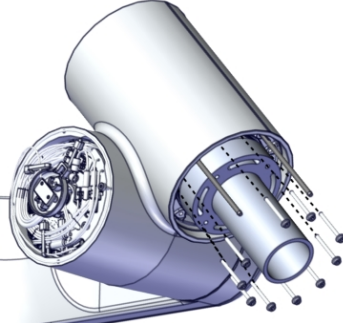
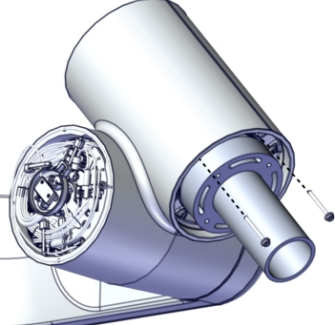
	Action	Note
5	<p>Fit the joint unit to the tilt, aligning the pin with the pin hole.</p> <p> CAUTION</p> <p>The connectors and the joint unit cables are sensitive to mechanical damage. Handle the assembly with care.</p>	 <p>xx2000002195</p>
6	<p>Secure the joint unit with new attachment screws.</p>	<p>Flange socket head screw with glue: 3HAB3413-330 M3x30 12.9 Lafre 2C2B/FC6.9+PrO-COat111, with NYPLAS glue, 12 pcs Used for joint unit of CRB 15000-5/0.95.</p> <p>Always use new screws when refitting a joint unit. If ordering a new joint unit spare part, new screws are included.</p>  <p>xx2100000329</p>
7	<p>Remove the guide pins and secure the remaining two attachment screws.</p>	 <p>xx2000002170</p>
8	<p>Pre-tighten the screws crosswise.</p>	
9	<p>Torque tighten all screws crosswise.</p>	<p>Tightening torque: 1.4 Nm (for CRB 15000-5/0.95) / 1.9 Nm (for CRB 15000-10/1.52 and CRB 15000-12/1.27)</p>

Continues on next page

5.4.4 Replacing the wrist housing
Continued

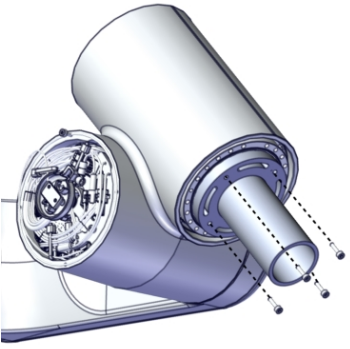
	Action	Note
10	Remove the lifting aid by removing the screws.	 <p>xx2000002168</p>
11	Clean pushed-out flange sealant, if any.	

Connecting the axis-6 joint unit cabling

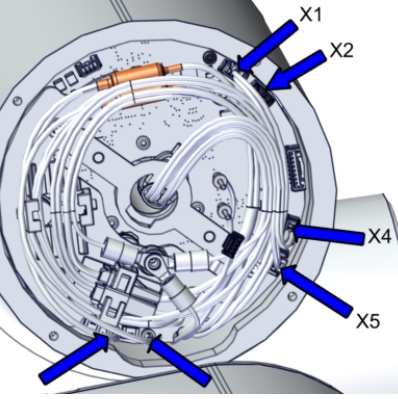
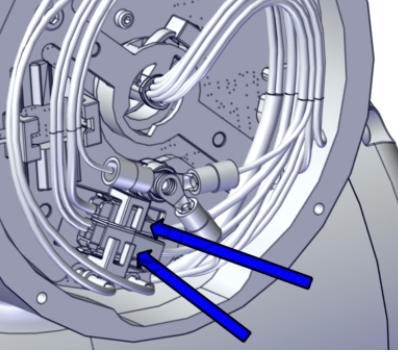
	Action	Note
1	Reconnect the connectors to the drive board. <ul style="list-style-type: none"> • D6.X1 to X1 • D6.DC+ to +DC • D6.DC- to Ground • D6.X4 to X4 • D6.X2 to X2 • D6.X5 to X5 	 <p>xx2000002164</p>
2	Connect the connectors to each other and snap them to the cable holders. <ul style="list-style-type: none"> • J7.CS to J7.CS • J7.CP to J7.CP 	 <p>xx2000002163</p>

Continues on next page

5 Repair

5.4.4 Replacing the wrist housing

Continued

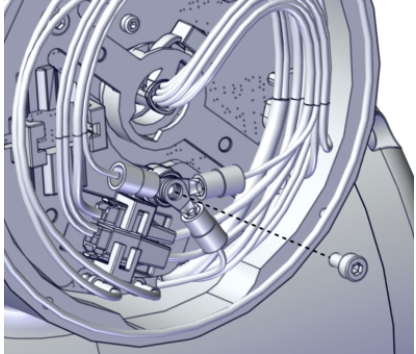
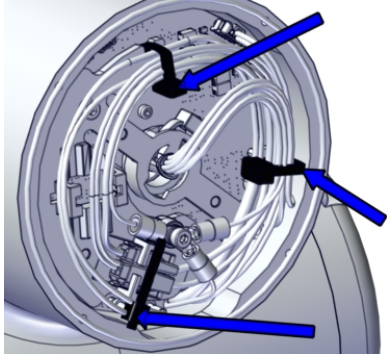
	Action	Note
3	Secure the cables for functional earth and protective earth with a screw.	Hex socket head cap screw: M3x6 (1 pcs). Tightening torque: 0.8 Nm.  xx2000002162
4	Secure the cabling with cable ties.	Cable ties (3 pcs)  xx2000002161

Refitting the arm-side interface

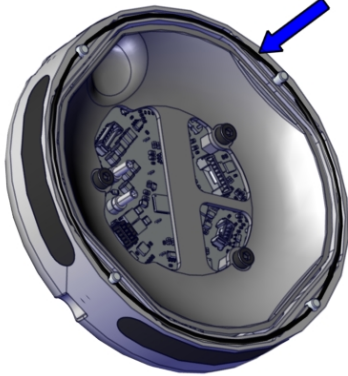
	Action	Note
1	Fit the o-ring to its groove. Replace if damaged.	O-ring: 3HAC061327-051  xx2000002551

Continues on next page

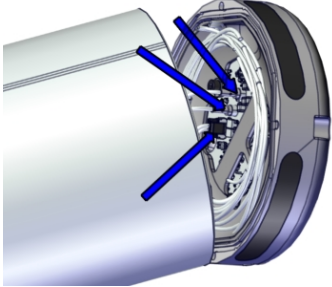
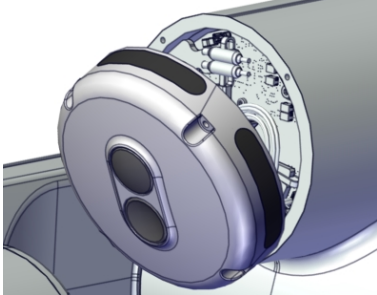
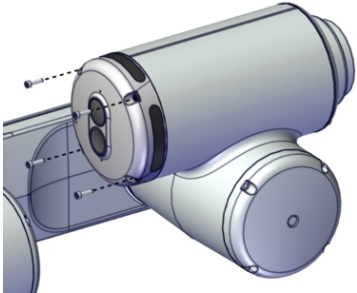
	Action	Note
2	<p>Place the arm-side interface at mounting position and reconnect the connectors.</p> <ul style="list-style-type: none"> • ASI.DC+ • ASI.DC- • ASI.X1 <p>The correct orientation of the arm-side interface is with the convex button in upper position.</p> <p> Note</p> <p>Do not leave the arm-side interface in location without being secured with the attachment screws.</p>	 <p>xx2100000335</p>  <p>xx2100000336</p>
3	<p>Refit the arm-side interface with four screws.</p>	<p>Valid for CRB 15000-5/0.95 Hex socket head cap screw: M3x30 12.9 Lafre 2C2B/FC6.9 (4 pcs) Tightening torque: 0.45 Nm</p> <p>Valid for CRB 15000-10/1.52 and CRB 15000-12/1.27 Hex socket head cap screw: M3x20 12.9 Lafre 2C2B/FC6.9 (4 pcs) Tightening torque: 0.45 Nm</p>  <p>xx2000002550</p>

Continues on next page

5 Repair

5.4.4 Replacing the wrist housing

Continued

Refitting the tool flange adapter

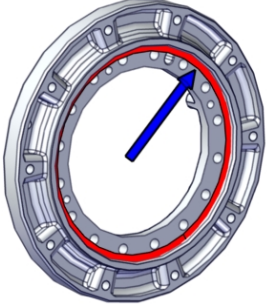
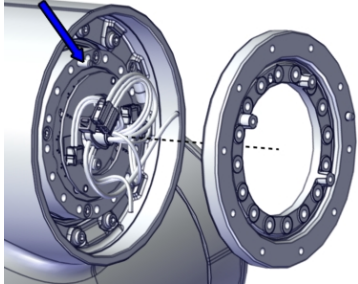
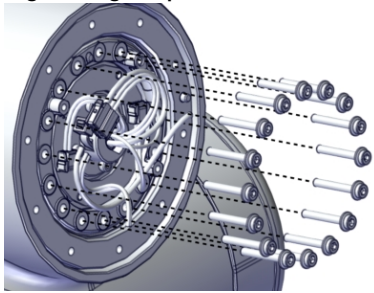
	Action	Note
1	Clean the mounting surface with isopropanol. Apply flange sealant to the corner of the adapter mounting surface, as pointed out in the figure.	Cleaning agent: Isopropanol Flange sealant: Loctite 574  xx2000002196
2	Refit the tool flange adapter, aligning the pin with the pin hole.	Axis-6 inner flange: 3HAC073952-001  xx2000002167
3	Secure with screws.	Flange socket head screw: M3x20 12.9 Lafre 2C2B/FC6.9+PrO-COat111 (16 pcs) Tightening torque: 1.8 Nm.  xx2000002165

Continues on next page

5.4.4 Replacing the wrist housing
Continued

Connecting the tool flange functional earth cable

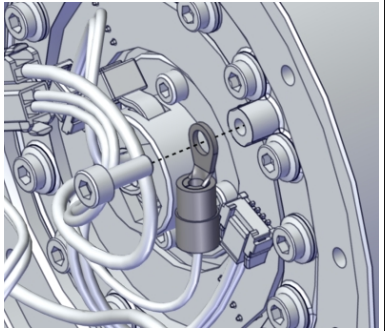
	Action	Note
1	Secure the cable for functional earth to the tool flange adapter with a screw.	 <p>xx2000002159</p>

Refitting the tool flange

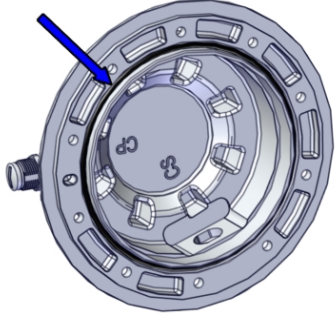
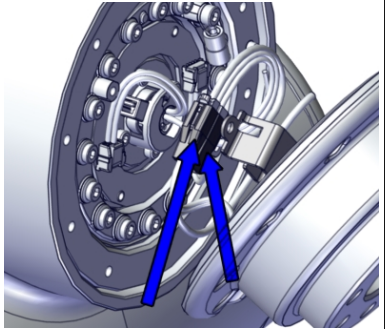
	Action	Note
1	Check the o-ring on the tool flange and lubricate with grease. Replace if damaged.	<p>Axis-6 flange: 3HAC073953-001 O-ring: 3HAB3772-182 Grease: 3HAC042536-001 (Shell Gadus S2)</p>  <p>xx2000002197</p>
2	Place the tool flange at mounting position and reconnect the CP/CS connectors.	 <p>xx2000002158</p>

Continues on next page

5 Repair

5.4.4 Replacing the wrist housing

Continued

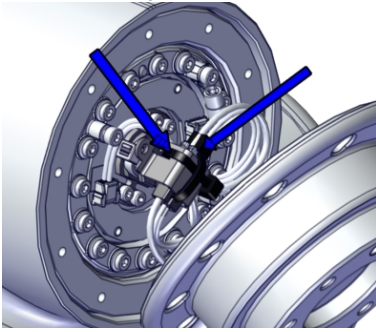
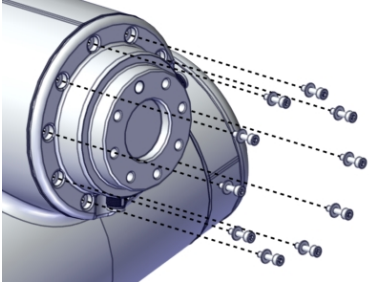
	Action	Note
3	Fit the connectors to the cable bracket and secure the connectors with two cable ties.	<p>Cable ties (2 pcs)</p>  <p>xx2000002157</p>
4	Refit and secure the tool flange with screws and washers.	<p>Hex socket head cap screw: M3x12 12.9 Lafre 2C2B/FC6.9 (10 pcs) Spring washer: 7x3.2x0.6 Steel (10 pcs) Tightening torque: 1.8 Nm.</p>  <p>xx2000002155</p>

Refitting the tilt

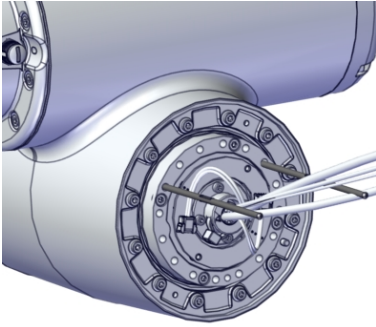
	Action	Note
1	Fit two guide pins to the axis-5 joint.	<p>Guide pin, M3x110: 3HAC077787-001 Always use guide pins in pairs.</p>  <p>xx2000002146</p>

Continues on next page

5.4.4 Replacing the wrist housing
Continued

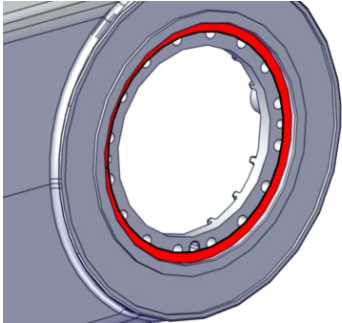
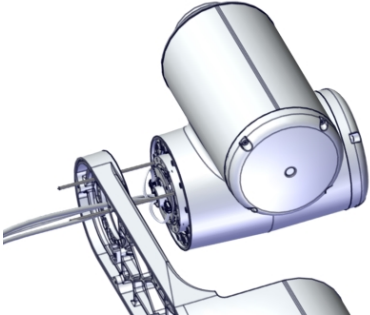
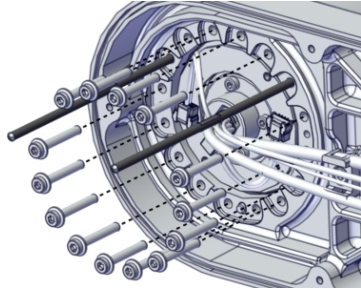
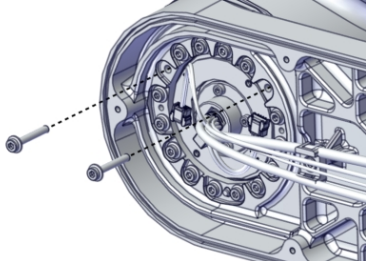
	Action	Note
2	Clean the mounting surface with isopropanol. Apply flange sealant to the corner of the tubular mounting surface, as pointed out in the figure.	<p>Cleaning agent: Isopropanol Flange sealant: Loctite 574</p>  <p>xx2000002147</p>
3	Lift the tilt into mounting position while inserting the cabling into the tubular.	 <p>xx2000002131</p>
4	Slide the tilt into place on the guide pins.	
5	Secure the tilt to the tubular with all attachment screws but two. Pre-tighten the screws crosswise firstly.	<p>Flange socket head screw: M3x20 12.9 Lafre 2C2B/FC6.9+PrO- COat111 (14 pcs)</p>  <p>xx2000002130</p>
6	Remove the guide pins and fasten the remaining two screws.	<p>Flange socket head screw: M3x20 12.9 Lafre 2C2B/FC6.9+PrO- COat111 (2 pcs)</p>  <p>xx2000002128</p>
7	Torque tighten all screws crosswise.	Tightening torque: 1.8 Nm.

Continues on next page

5 Repair

5.4.4 Replacing the wrist housing

Continued

Connecting the tilt cabling

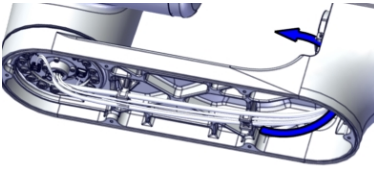
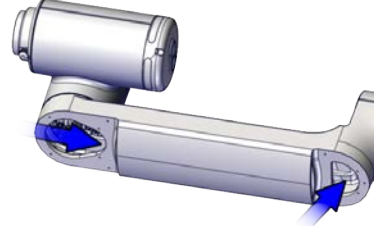
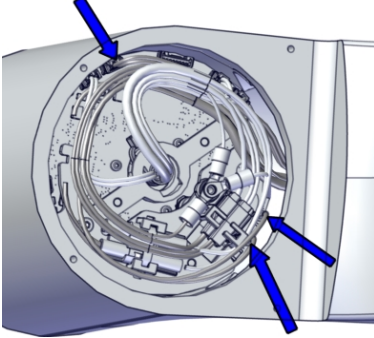
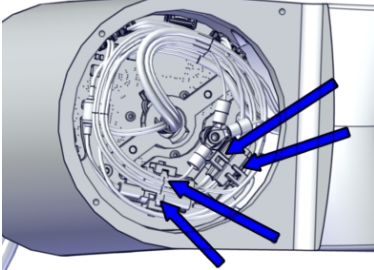
	Action	Note
1	Insert the cabling into the tubular.	<p>Valid for CRB 15000-5/0.95</p>  <p>xx2000002148</p> <p>Valid for CRB 15000-10/1.52 and CRB 15000-12/1.27</p>  <p>xx2300000845</p>
2	<p>Reconnect the connectors to the drive board.</p> <ul style="list-style-type: none"> • D3/4.X2 to X2 • D3/4.DC- to Ground • D3/4.DC+ to +DC 	 <p>xx2000002125</p>
3	<p>Connect the connectors to each other and snap them to the cable holders.</p> <ul style="list-style-type: none"> • J4/5.DC+ to J5/6.DC+ • J4/5.DC- to J5/6.DC- • J4/5.CS to J5/6.CS • J4/5.CP to J5/6.CP 	 <p>xx2000002089</p>

Continues on next page

5.4.4 Replacing the wrist housing
Continued

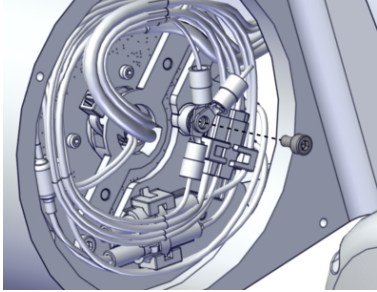
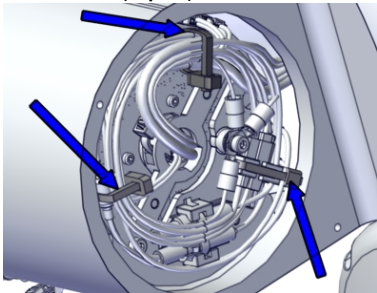
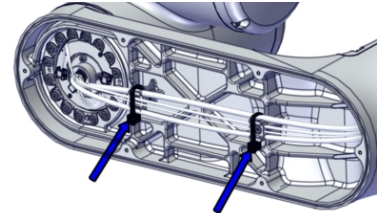
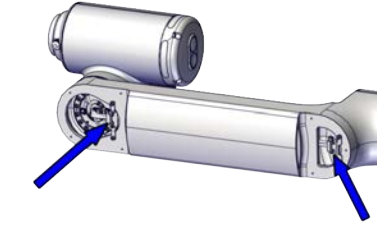
	Action	Note
4	Secure the cables for functional earth and protective earth with a screw.	<p>Hex socket head cap screw: M3x6 (1 pcs). Tightening torque: 0.8 Nm.</p>  <p>xx2000002087</p>
5	Secure the cabling to joint unit with cable ties.	<p>Cable ties (3 pcs)</p>  <p>xx2000002086</p>
6	Secure the cabling to tubular with cable ties.	<p>Cable ties (2 pcs) Valid for CRB 15000-5/0.95</p>  <p>xx2000002124</p> <p>Valid for CRB 15000-10/1.52 and CRB 15000-12/1.27</p>  <p>xx2300000842</p>

Continues on next page

5 Repair

5.4.4 Replacing the wrist housing

Continued

Refitting the tubular cover (-5/0.95)

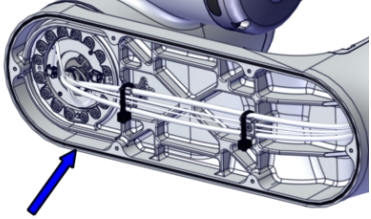
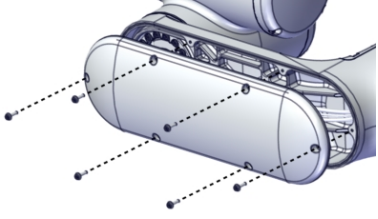
	Action	Note
1	Wipe, lubricate and fit the o-ring to its groove. Replace if damaged.	<p>O-ring: 3HAC061327-043 Grease: 3HAC042536-001 (Shell Gadus S2)</p>  <p>xx2000002149</p>
2	Refit the cover with new attachment screws.	<p>Flange socket head screw with glue: 3HAB3413-312 M3x12 12.9 Lafre 2C2B/FC6.9+PrO-COat111, with NYPLAS glue For tubular cover of CRB 15000-5/0.95. Always use new screws. If ordering a new axis-4 or axis-5 joint unit spare part, new screws for the tubular cover are included. Tightening torque: 1.6 Nm.</p>  <p>xx2000002123</p>

Continues on next page

5.4.4 Replacing the wrist housing
Continued

Refitting the tubular cover (-10/1.52 and -12/1.27)

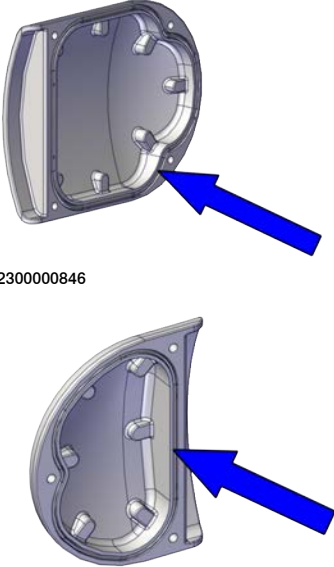
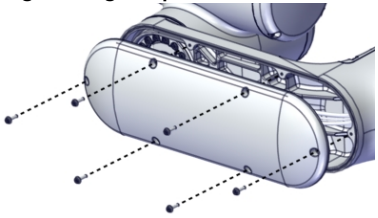
	Action	Note
1	Wipe, lubricate and fit the o-ring to its groove. Replace if damaged.	<p>O-ring: 3HAC061327-076 O-ring: 3HAB3772-166 Grease: 3HAC042536-001 (Shell Gadus S2)</p>  <p>xx2300000846</p> <p>xx2300000847</p>
2	Refit the covers with new attachment screws.	<p>Hex socket head cap screw: 3HAB3409-224 M3x12 12.9 Lafre 2C2B/FC6.9 (3 pcs) Tightening torque: 1.4 Nm.</p>  <p>xx2000002123</p>

Concluding procedure

	Action	Note
1	Calibrate the axis-5 and axis-6 joint unit torque sensor.	See Calibration on page 1063
2	 <p>DANGER</p> <p>Make sure all safety requirements are met when performing the first test run. See Test run after installation, maintenance, or repair on page 90.</p>	

5 Repair

5.4.5 Replacing the tool flange and axis-6 inner flange

5.4.5 Replacing the tool flange and axis-6 inner flange

Location of the tool flange and axis-6 inner flange

The tool flange is located as shown in the figure. The axis-6 inner flange is located beneath the tool flange.

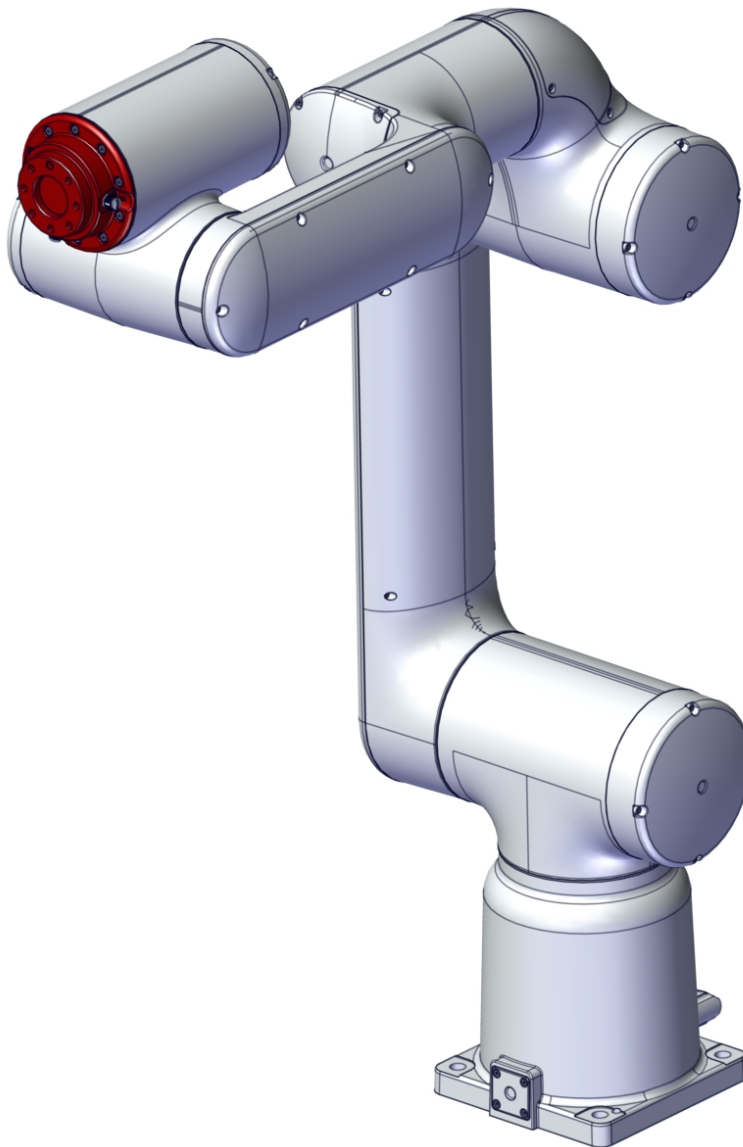

xx210000054

Required spare parts



Note

The spare part numbers that are listed in the table can be out of date. See the latest spare parts of the CRB 15000 via myABB Business Portal, www.abb.com/myABB.

Continues on next page

5.4.5 Replacing the tool flange and axis-6 inner flange

Continued

Spare part	Article number	Note
Axis-6 flange	3HAC073953-001	
Axis-6 inner flange	3HAC073952-001	

Required tools and equipment

Equipment	Article number	Note
Standard toolkit	-	Content is defined in section Standard toolkit on page 1099 .

Required consumables

Consumable	Article number	Note
Cleaning agent	-	Isopropanol
Flange sealant	-	Loctite 574
Grease	3HAC042536-001	Shell Gadus S2
O-ring	3HAB3772-182	Tool flange
Cable ties	-	

Removing the tool flange and axis-6 inner flange

Use these procedures to remove the tool flange and axis-6 inner flange.

Preparations before removing the flanges

	Action	Note
1	Decide which calibration routine to use, and take actions accordingly prior to beginning the repair procedure.	
2	Jog the robot to the specified position: <ul style="list-style-type: none"> Axis 1: No significance. Axis 2: No significance. Axis 3: No significance. Axis 4: No significance. Axis 5: No significance. Axis 6: 0° 	
3	 CAUTION Turn off all supplies for electrical power to the robot, before starting the repair work.	



Continues on next page

5 Repair

5.4.5 Replacing the tool flange and axis-6 inner flange

Continued

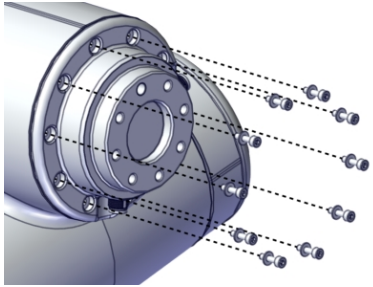
Removing the tool flange

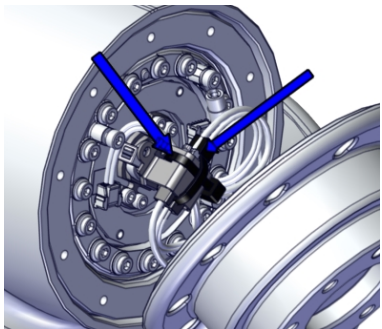
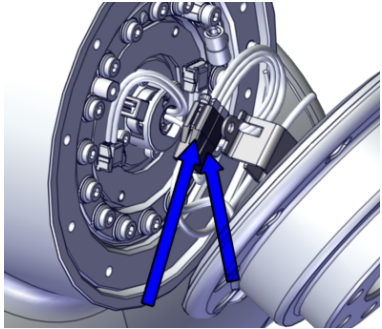
	Action	Note
1	Remove the tool flange screws and washers.	 xx2000002155
2	 CAUTION Valid for CRB 15000-5/0.95 There is cabling connected between the cover and the joint unit drive board. Open the cover with care to avoid damage to the cabling or the connector(s). Do not leave the cover in location without being secured with the attachment screws.	
3	Cut the cable ties.	 xx2000002157
4	Disconnect the CP/CS connectors from the drive board and remove the tool flange.	 xx2000002158

Continues on next page

5.4.5 Replacing the tool flange and axis-6 inner flange
Continued

Disconnecting the tool flange functional earth cable

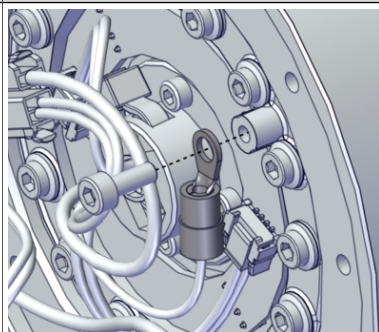
	Action	Note
1	Remove the functional earth cable by removing the screw.	 <p>xx2000002159</p>

Removing the tool flange adapter

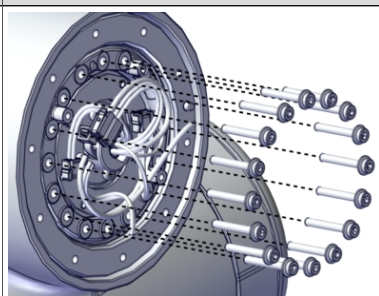
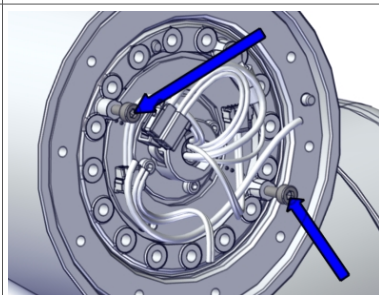
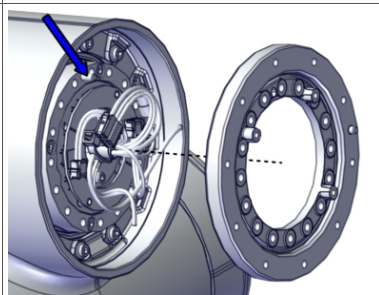
	Action	Note
1	Remove the tool flange adapter screws.	 <p>xx2000002165</p>
2	Press the adapter out of position by using two of the attachment screws as removal tools.	 <p>xx2000002166</p>
3	Remove the tool flange adapter.	 <p>xx2000002167</p>

Continues on next page

5 Repair

5.4.5 Replacing the tool flange and axis-6 inner flange

Continued

Refitting the flanges

Use these procedures to refit the tool flange and axis-6 inner flange.

Refitting the tool flange adapter

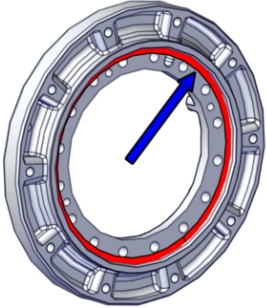
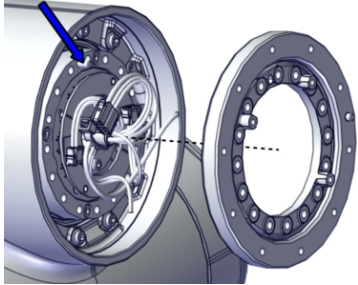
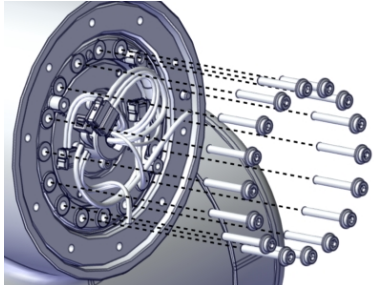
	Action	Note
1	Clean the mounting surface with isopropanol. Apply flange sealant to the corner of the adapter mounting surface, as pointed out in the figure.	Cleaning agent: Isopropanol Flange sealant: Loctite 574  xx2000002196
2	Refit the tool flange adapter, aligning the pin with the pin hole.	Axis-6 inner flange: 3HAC073952-001  xx2000002167
3	Secure with screws.	Flange socket head screw: M3x20 12.9 Lafre 2C2B/FC6.9+PrO-COat111 (16 pcs) Tightening torque: 1.8 Nm.  xx2000002165

Continues on next page

5.4.5 Replacing the tool flange and axis-6 inner flange
Continued

Connecting the tool flange functional earth cable

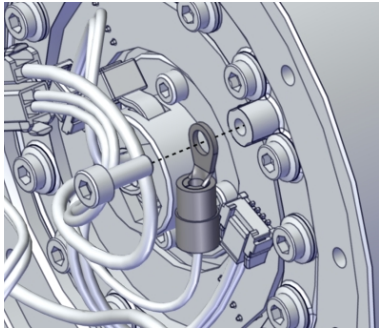
	Action	Note
1	Secure the cable for functional earth to the tool flange adapter with a screw.	 <p>xx2000002159</p>

Refitting the tool flange

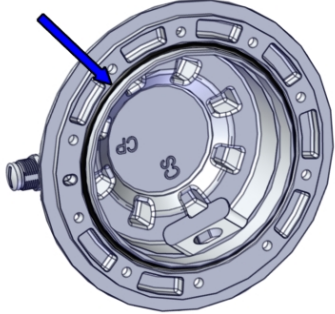
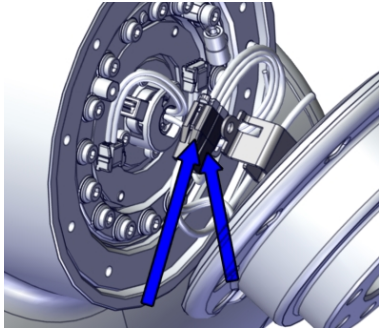
	Action	Note
1	Check the o-ring on the tool flange and lubricate with grease. Replace if damaged.	<p>Axis-6 flange: 3HAC073953-001 O-ring: 3HAB3772-182 Grease: 3HAC042536-001 (Shell Gadus S2)</p>  <p>xx2000002197</p>
2	Place the tool flange at mounting position and reconnect the CP/CS connectors.	 <p>xx2000002158</p>

Continues on next page

5 Repair

5.4.5 Replacing the tool flange and axis-6 inner flange

Continued

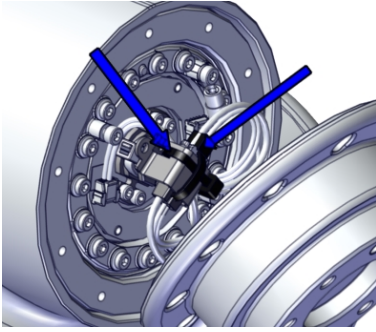
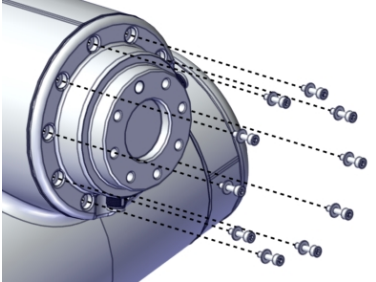
	Action	Note
3	Fit the connectors to the cable bracket and secure the connectors with two cable ties.	Cable ties (2 pcs)  <small>xx2000002157</small>
4	Refit and secure the tool flange with screws and washers.	Hex socket head cap screw: M3x12 12.9 Lafre 2C2B/FC6.9 (10 pcs) Spring washer: 7x3.2x0.6 Steel (10 pcs) Tightening torque: 1.8 Nm.  <small>xx2000002155</small>

Concluding procedure

	Action	Note
1	 DANGER Make sure all safety requirements are met when performing the first test run. See Test run after installation, maintenance, or repair on page 90 .	

5.4.6 Replacing the arm-side interface

Location of the arm-side interface

The arm-side interface is located as shown in the figure.

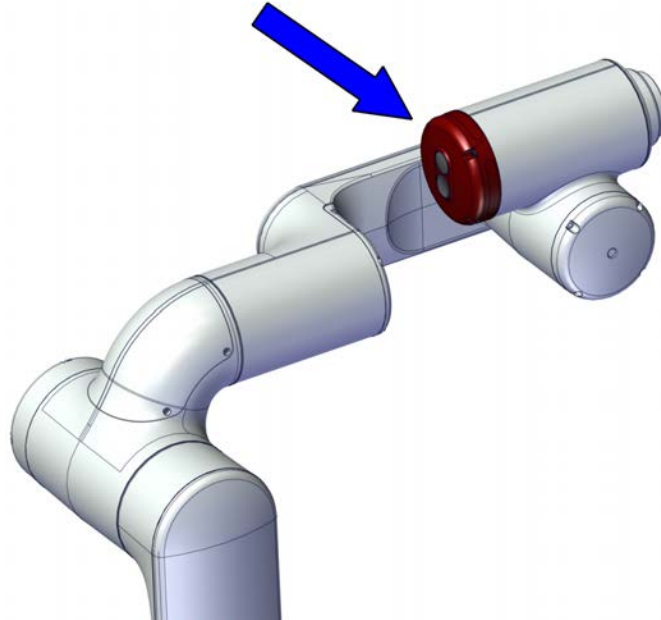

xx2000002549

Required spare parts



Note

The spare part numbers that are listed in the table can be out of date. See the latest spare parts of the CRB 15000 via myABB Business Portal, www.abb.com/myABB.

Spare part	Article number	Note
Arm side interface	3HAC076855-001	

Required tools and equipment

Equipment	Article number	Note
Standard toolkit	-	Content is defined in section Standard toolkit on page 1099 .

Required consumables

Consumable	Article number	Note
O-ring	3HAC061327-051	Arm-side interface Replace if damaged.
Cable ties	-	

Continues on next page

5 Repair

5.4.6 Replacing the arm-side interface

Continued



Removing the arm-side interface

Use these procedures to remove the arm side interface.

Preparations before removing the arm-side interface

	Action	Note
1	Jog the robot to a position where the arm side interface is easily accessed.	
2	 CAUTION Turn off all supplies for electrical power to the robot, before starting the repair work.	

Removing the arm-side interface

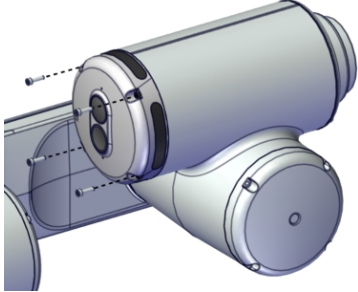
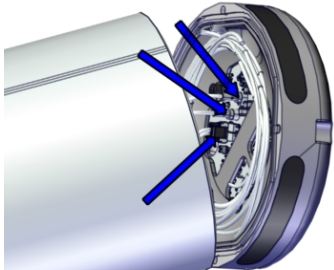

	Action	Note
1	 CAUTION Make sure that all supplies for electrical power are turned off.	
2	 CAUTION There is cabling connected between the arm-side interface and the joint unit drive board. Open the arm-side interface with care to avoid damage to the cabling or the connector(s). Do not leave the arm-side interface in location without being secured with the attachment screws.	
3	Remove the attachment screws.	 xx2000002550
4	Loosen the arm-side interface carefully and disconnect the connectors from it. <ul style="list-style-type: none">• ASI.DC+• ASI.DC-• ASI.X1	 xx2100000335

Continues on next page

Refitting the arm-side interface

Use these procedures to refit the arm-side interface.

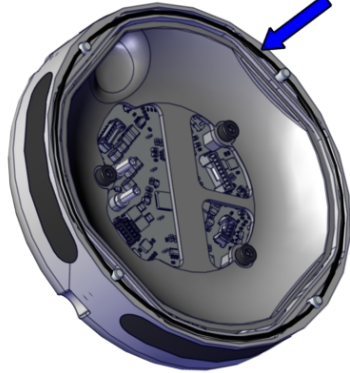
Refitting the arm-side interface

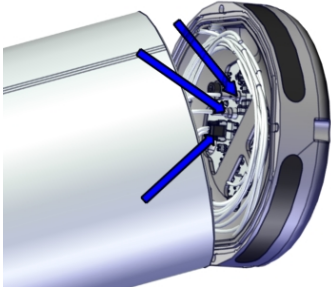
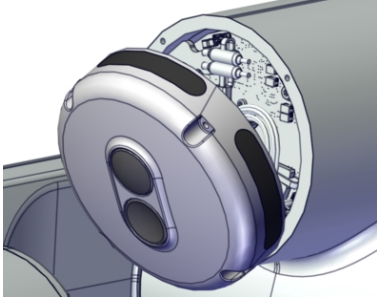
	Action	Note
1	<p>Fit the o-ring to its groove. Replace if damaged.</p>	<p>O-ring: 3HAC061327-051</p>  <p>xx2000002551</p>
2	<p>Place the arm-side interface at mounting position and reconnect the connectors.</p> <ul style="list-style-type: none"> • ASI.DC+ • ASI.DC- • ASI.X1 <p>The correct orientation of the arm-side interface is with the convex button in upper position.</p> <p> Note</p> <p>Do not leave the arm-side interface in location without being secured with the attachment screws.</p>	 <p>xx2100000335</p>  <p>xx2100000336</p>

Continues on next page

5 Repair

5.4.6 Replacing the arm-side interface

Continued

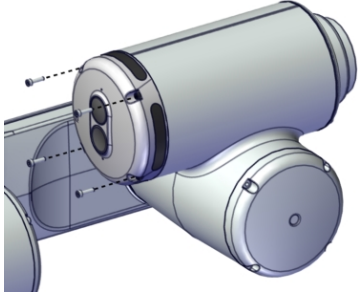
	Action	Note
3	Refit the arm-side interface with four screws.	<p>Valid for CRB 15000-5/0.95 Hex socket head cap screw: M3x30 12.9 Lafre 2C2B/FC6.9 (4 pcs) Tightening torque: 0.45 Nm</p> <p>Valid for CRB 15000-10/1.52 and CRB 15000-12/1.27 Hex socket head cap screw: M3x20 12.9 Lafre 2C2B/FC6.9 (4 pcs) Tightening torque: 0.45 Nm</p>  <p>xx2000002550</p>

Concluding procedure

	Action	Note
1	 DANGER Make sure all safety requirements are met when performing the first test run. See Test run after installation, maintenance, or repair on page 90 .	

5.5 Swing and base

5.5.1 Replacing the base

Location of the base

The base is located as shown in the figure.

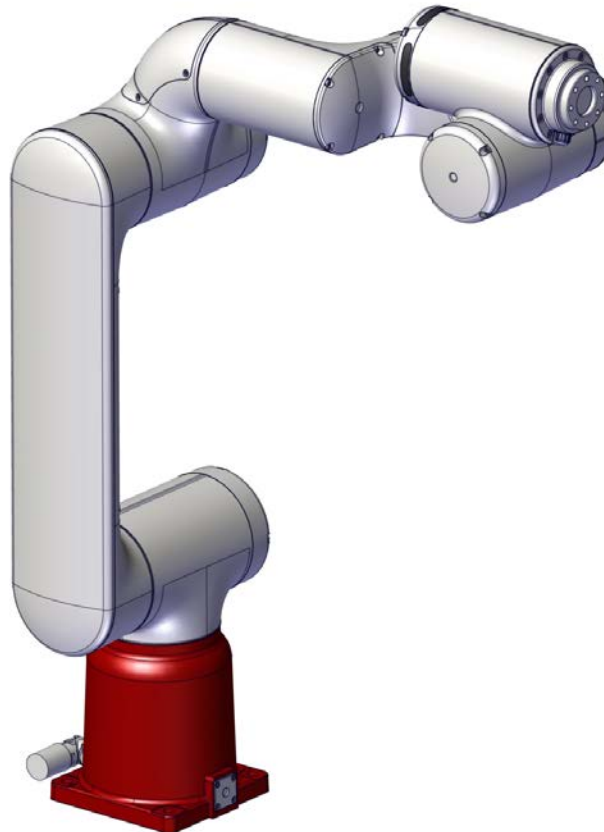

xx210000422

Summary of the replacement procedure

This is a brief summary of the replacement procedure, containing the major actions to be performed.

- 1 Separate the cabling between the swing and the lower arm.
- 2 Remove the lower and upper arm undivided.
- 3 Remove the axis-2 joint unit.
- 4 Remove the swing.
- 5 Loosen the base from the foundation and lay it down on its side.
- 6 Remove the axis-1 joint unit.
- 7 Replace the base. Move the base cabling and axis-1 brake release unit from old to new base.

Continues on next page

5 Repair

5.5.1 Replacing the base

Continued

Required spare parts



Note

The spare part numbers that are listed in the table can be out of date. See the latest spare parts of the CRB 15000 via myABB Business Portal, www.abb.com/myABB.

Spare part	Article number	Note
Base	3HAC073922-001	Used for CRB 15000-5/0.95. Also order new attachment screws for the axis-1 and axis-2 joint unit: 3HAB3413-435 (24 pcs).
Base	3HAC081047-001	Used for CRB 15000-10/1.52 and CRB 15000-12/1.27.
Flange socket head screw with glue	3HAB3413-435	M4x35 12.9 Lafre 2C2B/FC6.9+PrO-COat111, with NYPLAS glue , 12 pcs Used for joint unit of CRB 15000-5/0.95. Always use new screws when re-fitting a joint unit. If ordering a new joint unit spare part, new screws are included.
Flange socket head screw with glue	3HAB3413-435	M4x35 12.9 Lafre 2C2B/FC6.9+PrO-COat111, with NYPLAS glue , 12 pcs Used for joint unit of CRB 15000-5/0.95. Always use new screws when re-fitting a joint unit. If ordering a new joint unit spare part, new screws are included.
Cable tie	3HAC075545-001	For securing joint unit cable.
Cable tie	3HAC075545-001	For securing joint unit cable.

Required tools and equipment

Equipment	Article number	Note
Lifting aid	3HAC077788-001	For joint units on axes 1, 2 and 3 of CRB 15000-5/0.95. Attachment screws M4x35 (4 pcs) are enclosed.
Lifting aid	3HAC087787-001	For joint units on axes 1 and 2 of CRB 15000-10/1.52 and CRB 15000-12/1.27. A plate, a beam, a pair of semicircular blocks and attachment screws M5x30 (2 pcs) are enclosed.

Continues on next page

5.5.1 Replacing the base
Continued

Equipment	Article number	Note
Guide pin, M4x120	3HAC077786-001	Always use guide pins in pairs. For joint units on axes 1, 2 and 3 of CRB 15000-5/0.95 and axis 3 of CRB 15000-10/1.52 and CRB 15000-12/1.27.
Guide pin, M5x125	3HAC087786-001	Always use guide pins in pairs. For joint units on axes 1 and 2 of CRB 15000-10/1.52 and CRB 15000-12/1.27.
Protection plate	3HAC077790-001	For protection of drive board during cabling installation on joint units of CRB 15000-5/0.95.
Protection plate	3HAC087789-001	For protection of drive board during cabling installation on joint units of CRB 15000-10/1.52 and CRB 15000-12/1.27.
Guide pin, M5x75	3HAC087786-002	Always use guide pins in pairs.
Cable tie gun EVO 7i	-	HellermannTyton 110-77001 or similar
Standard toolkit	-	Content is defined in section Standard toolkit on page 1099 .

Required consumables

Consumable	Article number	Note
Cleaning agent	-	Isopropanol
Flange sealant	-	Loctite 574
Grease	3HAC031695-001	Harmonic Grease 4B No.2 Used to lubricate the seals.
Grease	3HAC042536-001	Shell Gadus S2
O-ring	3HAB3772-119	Axis-1 brake release unit Replace if damaged.
O-ring	3HAC061327-044	Axis-1 and -2 joint unit, used for CRB 15000-10/1.52 and CRB 15000-12/1.27. Replace if damaged.
O-ring	3HAB3772-64	Base cover, used for CRB 15000-5/0.95.
O-ring	3HAC061327-072	Base cover, used for CRB 15000-10/1.52 and CRB 15000-12/1.27.
O-ring	3HAC061327-044	Lower arm, inner cover of CRB 15000-5/0.95. 1 pcs / cover. Replace if damaged.
O-ring	3HAC061327-075	Lower arm, lower inner cover of CRB 15000-10/1.52 and CRB 15000-12/1.27. Replace if damaged.

Continues on next page

5 Repair

5.5.1 Replacing the base



Continued

Consumable	Article number	Note
O-ring	3HAC061327-047	Cover for axis 2/3, used for CRB 15000-5/0.95. Replace if damaged.
O-ring	3HAC061327-074	Swing cover, used for CRB 15000-10/1.52 and CRB 15000-12/1.27. Replace if damaged.
O-ring	3HAC061327-073	Swing flange, big side, used for CRB 15000-10/1.52. Replace if damaged.
O-ring	3HAC061327-044	Swing flange, small side, used for CRB 15000-10/1.52. Replace if damaged.
Cable tie	3HAC075545-001	For securing joint unit cable.
Cable ties	-	

Removing the base (-5/0.95)

Use these procedures to remove the base.

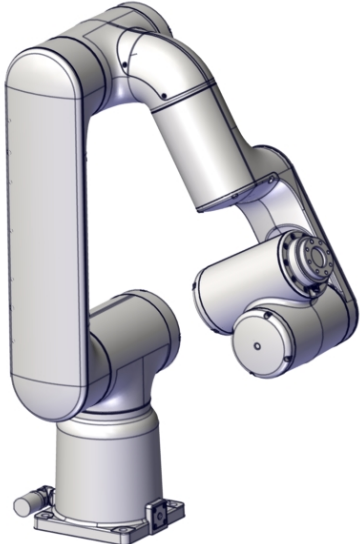
Preparations before removing the base

	Action	Note
1	<p>Jog the robot to the specified position:</p> <ul style="list-style-type: none"> • Axis 1: 0° • Axis 2: 0° • Axis 3: +60° • Axis 4: 0° • Axis 5: -90° • Axis 6: No significance. <p> CAUTION</p> <p>Jog the axis on which the joint unit is to be replaced to home position, to achieve correct cable routing during replacement of the joint unit.</p>	 <p>xx2100000044</p>
2	<p> CAUTION</p> <p>Turn off all supplies for electrical power to the robot, before starting the repair work.</p>	

Continues on next page

Removing the lower arm covers (-5/0.95)

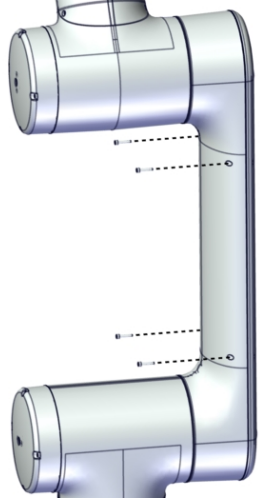
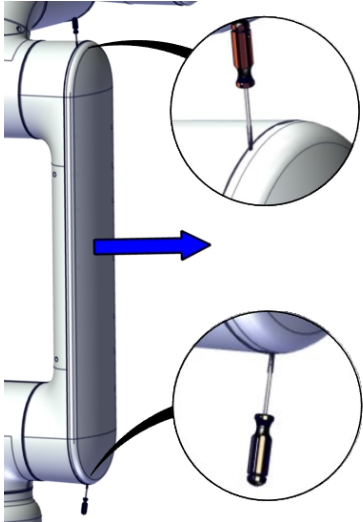
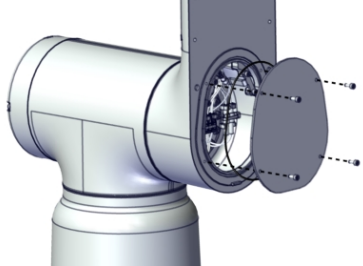
	Action	Note
1	 CAUTION Make sure that all supplies for electrical power are turned off.	
2	Remove the four lower arm cover screws.	 <p>xx2000001929</p>
3	Remove the cover by inserting a small flat screwdriver to snap open the locks at each end of the cover.	 <p>xx2100000267</p>
4	Remove the inner cover by removing the four screws.	 <p>xx2000001930</p>

Continues on next page

5 Repair

5.5.1 Replacing the base

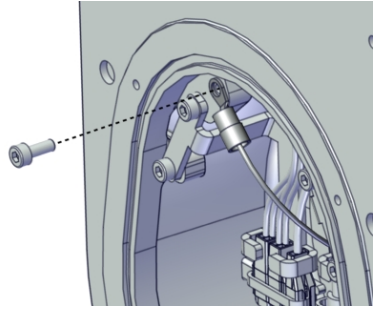
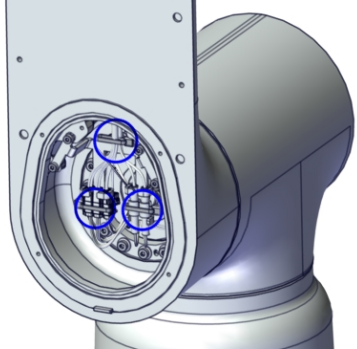
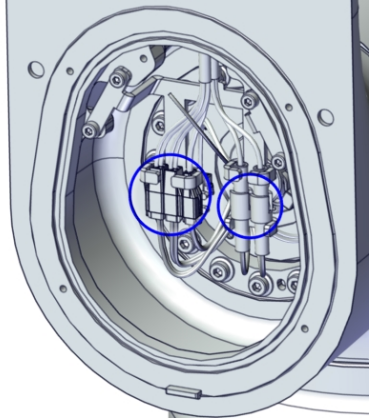

Continued

Disconnecting the cabling between the lower arm and the swing

	Action	Note
1	Remove the functional earth cable by removing the screw.	 xx2000001936
2	Cut the cable ties.	 xx2000001937
3	Snap loose and disconnect all connectors.	 xx2000001938

Continues on next page

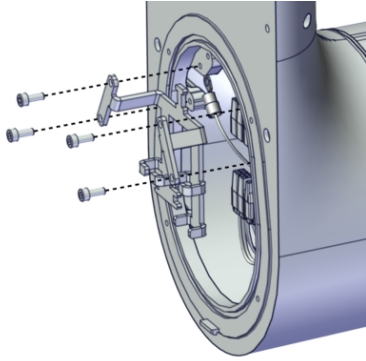
Removing the lower and upper arm assembled

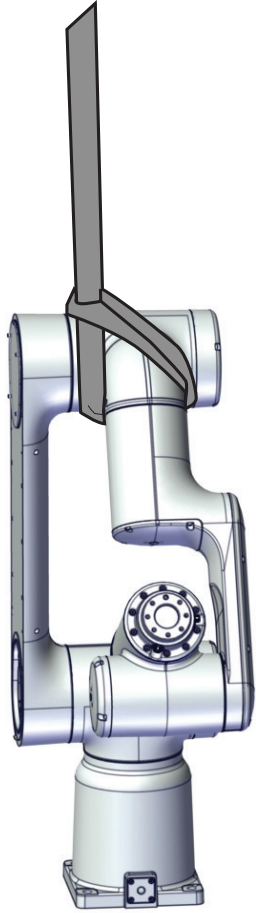

	Action	Note
1	Remove the cable bracket by removing the four screws.	 <p>xx200001939</p>
2	Secure the weight of the upper and lower arm.  CAUTION The weight of the complete upper and lower arm together is 18 kg	Suggestion with lifting sling and an overhead crane. Example of CRB 15000-5/0.95, similar to CRB 15000-10/1.52 and CRB 15000-12/1.27.  <p>xx2100000294</p>

Continues on next page

5 Repair

5.5.1 Replacing the base

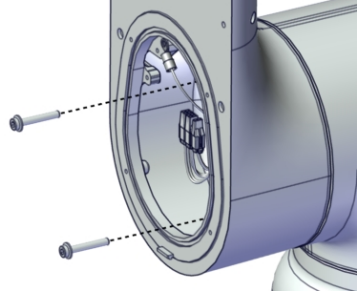
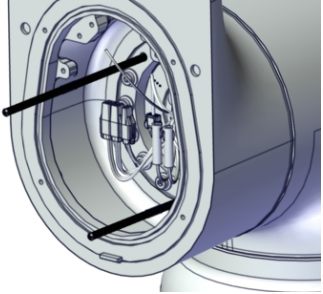
Continued

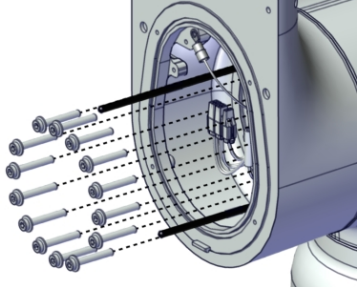
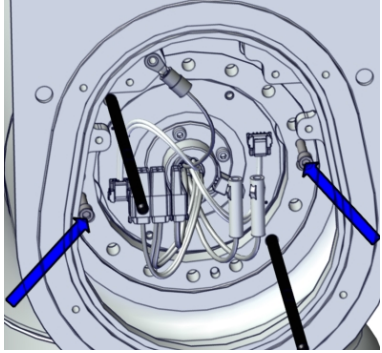
	Action	Note
3	<p>Remove two attachment screws and fit two guide pins to the axis-2 joint unit.</p> <p> CAUTION</p> <p>Do not mix the flange screws used for CRB 15000-5/0.95 and the threaded screws used for CRB 15000-10/1.52 and CRB 15000-12/1.27. Always use washers together with the threaded screws for CRB 15000-10/1.52 and CRB 15000-12/1.27. Illustration is for reference only.</p>	<p>Guide pin, M4x120: 3HAC077786-001</p> <p>Always use guide pins in pairs.</p>  <p>xx2000001951</p>  <p>xx2000001960</p>
4	<p>Remove the lower arm attachment screws.</p> <p> CAUTION</p> <p>Do not mix the flange screws used for CRB 15000-5/0.95 and the threaded screws used for CRB 15000-10/1.52 and CRB 15000-12/1.27. Always use washers together with the threaded screws for CRB 15000-10/1.52 and CRB 15000-12/1.27. Illustration is for reference only.</p>	 <p>xx2000001940</p>
5	<p>Use two fully threaded attachment screws as removal tools to press the lower arm out of position.</p>	 <p>xx2000002151</p>

Continues on next page

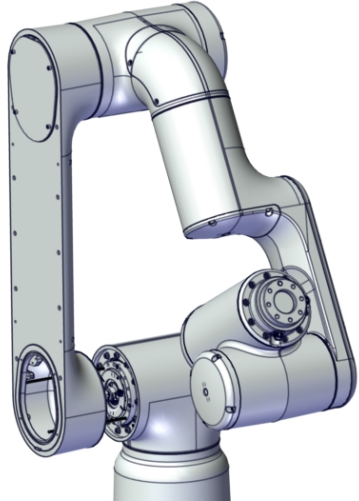
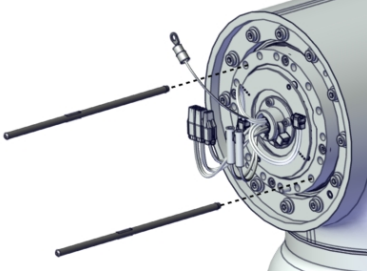
	Action	Note
6	Remove the complete arm system from the swing.	 <p>xx2000001941</p>
7	Remove the guide pins.	 <p>xx2000002432</p>

Removing the swing cover (-5/0.95)

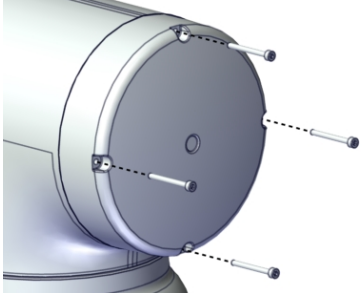
	Action	Note
1	 CAUTION Make sure that all supplies for electrical power are turned off.	
2	Remove the cover screws.	 <p>xx2000001935</p>

Continues on next page

5 Repair

5.5.1 Replacing the base

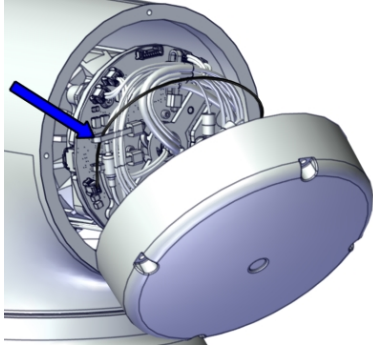
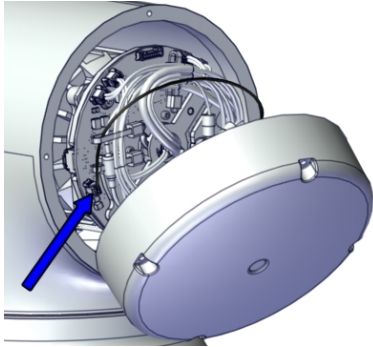

Continued

	Action	Note
3	 CAUTION Valid for CRB 15000-5/0.95 There is cabling connected between the cover and the joint unit drive board. Open the cover with care to avoid damage to the cabling or the connector(s). Do not leave the cover in location without being secured with the attachment screws.	
4	For robots with RobotWare earlier than 7.10 Open the cover and cut the cable tie that holds the brake release cable.	 xx2000001931
5	For robots with RobotWare earlier than 7.10 Disconnect the brake release connector DR.X8 from the drive board. Remove the cover.	 xx2000001932

Disconnecting the axis-2 joint unit cabling

	Action	Note
1	 ELECTROSTATIC DISCHARGE (ESD) The unit is sensitive to ESD. Before handling the unit read the safety information in section The unit is sensitive to ESD on page 53 .	

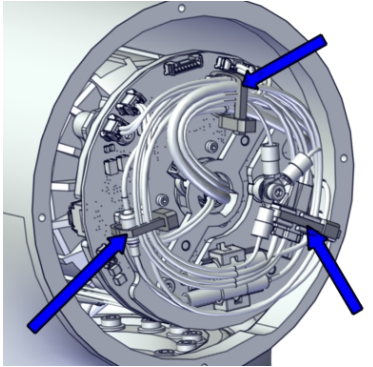
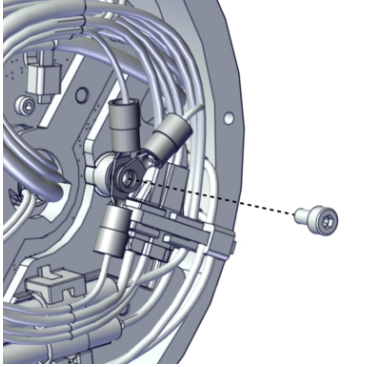
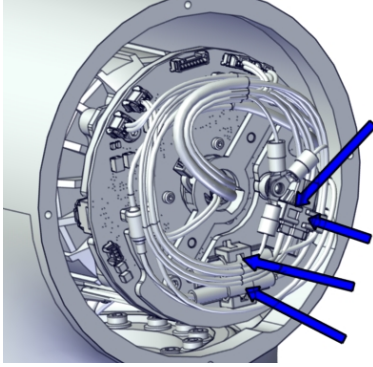
Continues on next page

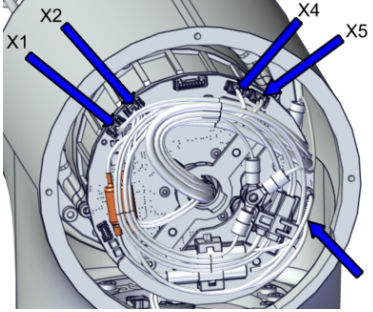
	Action	Note
2	Cut the cable ties.	 <p>xx2000001946</p>
3	Remove the functional and protective earth cables by removing the screw.	 <p>xx2000001945</p>
4	Snap loose and disconnect the connectors: <ul style="list-style-type: none"> • J2.DC+ • J2.DC- • J2.CS • J2.CP 	 <p>xx2000001944</p>
5	Disconnect the connectors from the drive board. <ul style="list-style-type: none"> • D2.X1 from X1 • D2.DC+ from DC+ • D2.DC- from ground • D2.X4 from X4 • D2.X2 from X2 • D2.X5 from X5 <p> CAUTION</p> <p>Use tweezers to unlock connectors and pull them off.</p>	 <p>xx2000002013</p>

Continues on next page

5 Repair



5.5.1 Replacing the base

Continued

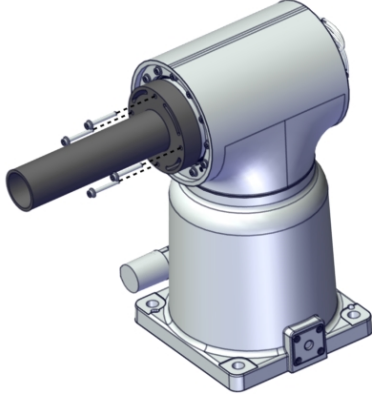
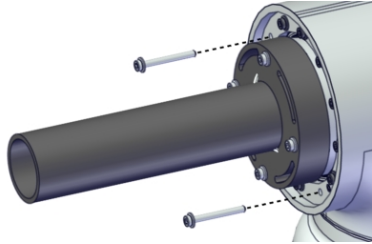
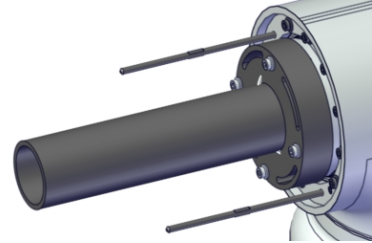
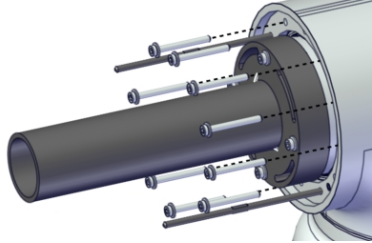
Removing the axis-2 joint unit (-5/0.95)

	Action	Note
1	<p>Fit the lifting aid to the joint unit, on the torque sensor side.</p> <p> CAUTION</p> <p>The connectors and the joint unit cables are sensitive to mechanical damage. Handle the assembly with care.</p>	<p>Lifting aid: 3HAC077788-001 Screws: M4x35 (4 pcs)</p>  <p>xx2000001956</p>
2	<p>Remove two attachment screws. Dispose the screws. New screws are included in the spare part delivery of the joint unit.</p>	 <p>xx2100000295</p>
3	<p>Fit two guide pins to the axis-2 joint unit.</p>	<p>Guide pin, M4x120: 3HAC077786-001 Always use guide pins in pairs. For joint units on axes 1, 2 and 3 of CRB 15000-5/0.95 and axis 3 of CRB 15000-10/1.52 and CRB 15000-12/1.27.</p>  <p>xx2000002433</p>
4	<p>Remove the remaining attachment screws. Use two screws as press out screws in the upcoming step, then dispose all screws. New screws are included in the spare part delivery of the joint unit.</p>	 <p>xx2000001943</p>

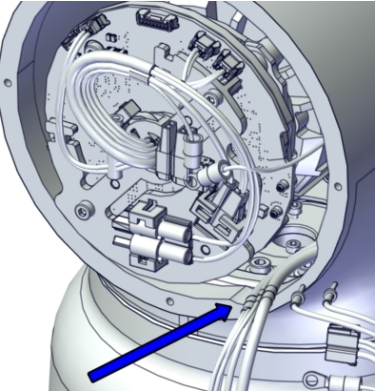
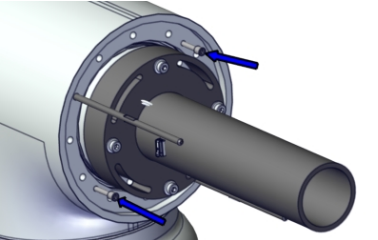
Continues on next page

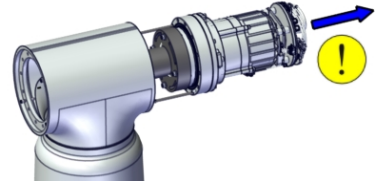
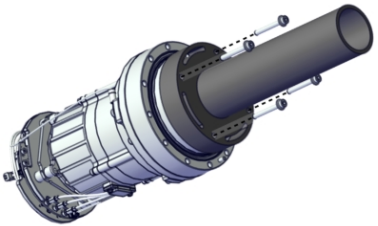
	Action	Note
5	Put the cabling at the slot in order not to squeeze it during removal of joint unit.	 <p>xx210000045</p>
6	Press the joint unit out of position using two of the previous attachment screws as removal tools.	 <p>xx2000002434</p>
7	<p>Remove the joint unit from the swing.</p> <p> CAUTION</p> <p>The connectors and the joint unit cables are sensitive to mechanical damage. Handle the assembly with care.</p>	 <p>xx2000001958</p>
8	Remove the lifting aid and guide pins.	 <p>xx2000001957</p>





Continues on next page

5 Repair

5.5.1 Replacing the base

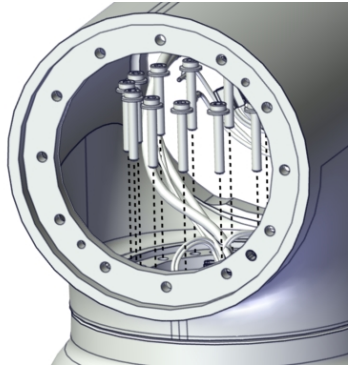
Continued

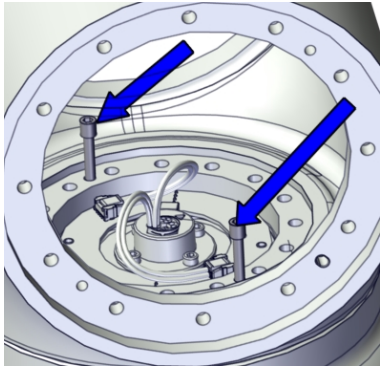
Removing the swing (-5/0.95)

	Action	Note
1	<p>Remove the swing attachment screws.</p> <p> CAUTION</p> <p>Do not mix the flange screws used for CRB 15000-5/0.95 and the threaded screws used for CRB 15000-10/1.52 and CRB 15000-12/1.27. Always use washers together with the threaded screws for CRB 15000-10/1.52 and CRB 15000-12/1.27. Illustration is for reference only.</p>	 <p>xx2000001987</p>
2	<p>Use two fully threaded attachment screws as removal tools to press the swing out of position.</p> <p> CAUTION</p> <p>Do not mix the flange screws used for CRB 15000-5/0.95 and the threaded screws used for CRB 15000-10/1.52 and CRB 15000-12/1.27. Always use washers together with the threaded screws for CRB 15000-10/1.52 and CRB 15000-12/1.27. Illustration is for reference only.</p>	 <p>xx2000002152</p>
3	<p>Lift away the swing.</p> <p> CAUTION</p> <p>The torque sensor (on the exposed PCBA) is sensitive to mechanical damage. Handle the assembly with care.</p>	

Loosening the base and removing the base cover

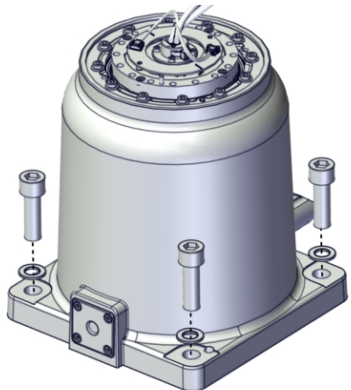
	Action	Note
1	<p>Loosen the base from the foundation by removing the attachment screws and washers.</p>	 <p>xx2000002006</p>

Continues on next page

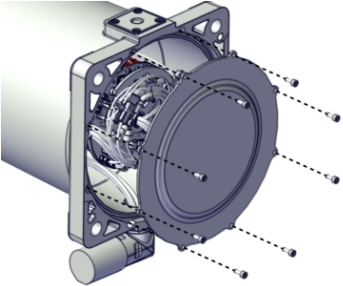
	Action	Note
2	Tilt the base on to its side and remove the bottom cover by removing the attachment screws.	 <p>xx2000002007</p>

Disconnecting the axis-1 joint unit cabling

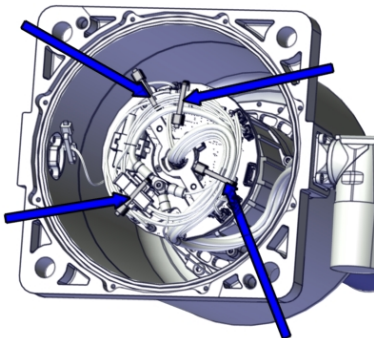
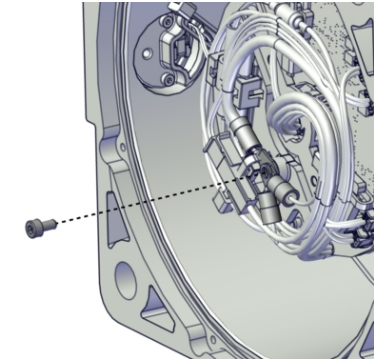
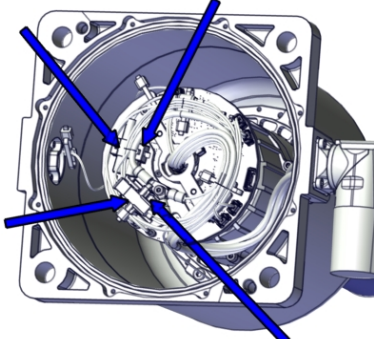
	Action	Note
1	Cut the cable ties.	 <p>xx2000002012</p>
2	Remove the functional and protective earth cables by removing the screw.	 <p>xx2000002011</p>
3	Snap loose and disconnect the connectors: <ul style="list-style-type: none"> • J1.DC+ • J1.DC- • J1.CS • J1.CP 	 <p>xx2000002010</p>

Continues on next page

5 Repair

5.5.1 Replacing the base

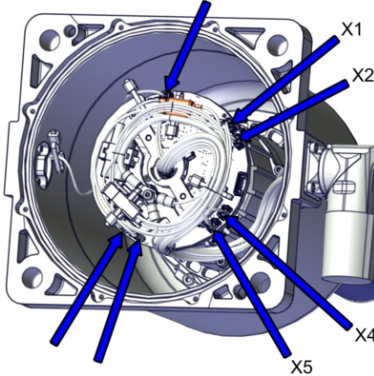

Continued

	Action	Note
4	<p>Disconnect the connectors from the drive board.</p> <ul style="list-style-type: none"> • D1.X1 from X1 • D1.DC+ from DC+ • D1.DC- from ground • D1.X4 from X4 • D1.X2 from X2 • D1.X5 from X5 • DR.X8 from X8 <p> CAUTION</p> <p>Use tweezers to unlock connectors and pull them off.</p>	 <p>xx2000002009</p>

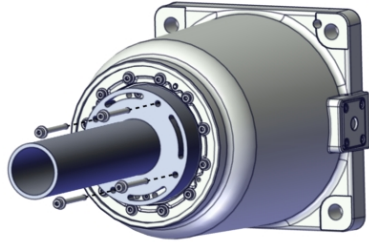
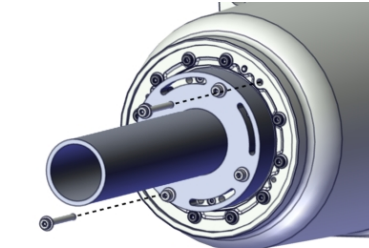
Removing the axis-1 joint unit (-5/0.95)

	Action	Note
1	<p>Fit the lifting aid to the joint unit.</p> <p> CAUTION</p> <p>The connectors and the joint unit cables are sensitive to mechanical damage. Handle the assembly with care.</p>	<p>Lifting aid: 3HAC077788-001 Screws: M4x35 (4 pcs)</p>  <p>xx2000001994</p>
2	<p>Remove two attachment screws. Dispose the screws. New screws are included in the spare part delivery of the joint unit.</p>	 <p>xx2100000296</p>

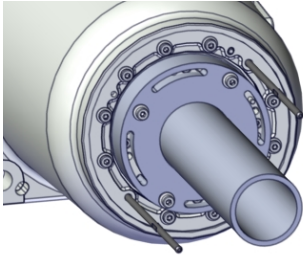
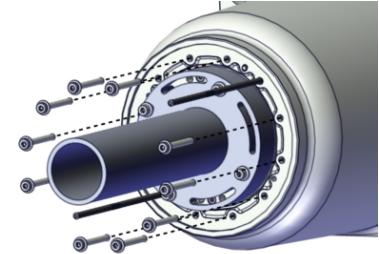
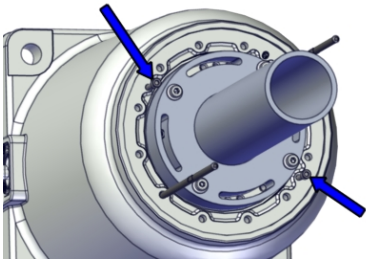
Continues on next page

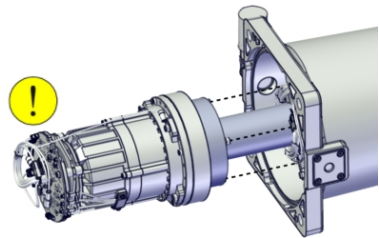
	Action	Note
3	Fit two guide pins to the axis-1 joint unit.	<p>Guide pin, M4x120: 3HAC077786-001</p> <p>Always use guide pins in pairs.</p> <p>For joint units on axes 1, 2 and 3 of CRB 15000-5/0.95 and axis 3 of CRB 15000-10/1.52 and CRB 15000-12/1.27.</p>  <p>xx2000002435</p>
4	<p>Remove the remaining attachment screws.</p> <p>Use two screws as press out screws in the upcoming step, then dispose all screws.</p> <p>New screws are included in the spare part delivery of the joint unit.</p>	 <p>xx2000002008</p>
5	Press the joint unit out of position using two of the previous attachment screws as removal tools.	 <p>xx2000002436</p>
6	<p>Remove the joint unit from the base.</p> <p> CAUTION</p> <p>The connectors and the joint unit cables are sensitive to mechanical damage. Handle the assembly with care.</p>	 <p>xx2000002014</p>

Continues on next page

5 Repair

5.5.1 Replacing the base

Continued

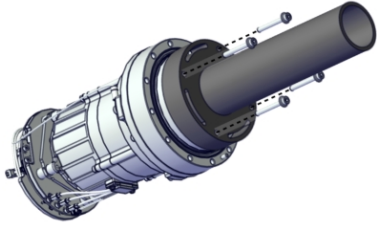
	Action	Note
7	Remove the lifting aid and guide pins.	 xx2000001957

Removing the base cabling

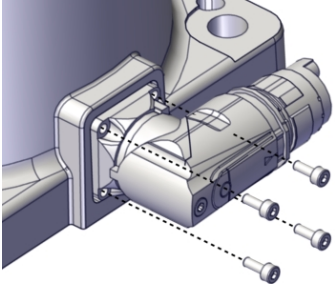
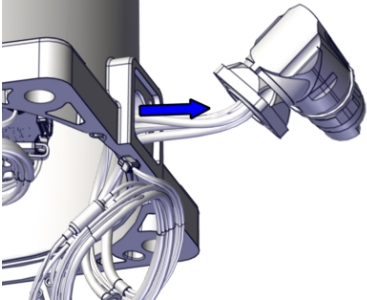
	Action	Note
1	Remove the attachment screws.	 xx2100000406
2	Pull out the cabling from the base.	 xx2100000407

Removing the brake release unit

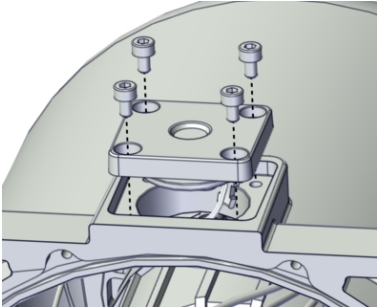

	Action	Note
1	Remove the brake release unit by removing the screws.	 xx2100000413

Continues on next page

Removing the base (-10/1.52 and -12/1.27)

Use these procedures to remove the base.

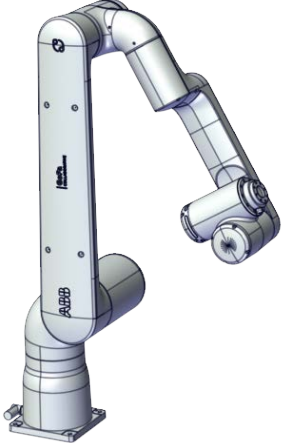
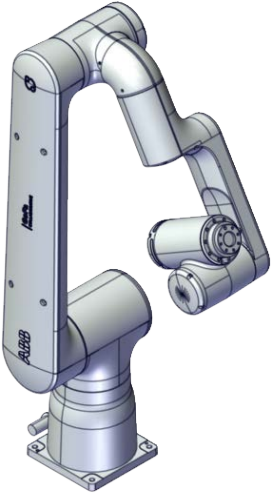
Preparations before removing the base

	Action	Note
1	<p>Jog the robot to the specified position:</p> <ul style="list-style-type: none"> • Axis 1: 0° • Axis 2: 0° • Axis 3: +60° • Axis 4: 0° • Axis 5: -90° • Axis 6: No significance. <p> CAUTION</p> <p>Jog the axis on which the joint unit is to be replaced to home position, to achieve correct cable routing during replacement of the joint unit.</p>	<p>Valid for CRB 15000-10/1.52</p>  <p>xx2300001062</p> <p>Valid for CRB 15000-12/1.27</p>  <p>xx2300001063</p>
2	<p> CAUTION</p> <p>Turn off all supplies for electrical power to the robot, before starting the repair work.</p>	

Continues on next page

5 Repair

5.5.1 Replacing the base

Continued

Removing the lower arm covers (-10/1.52 and -12/1.27)

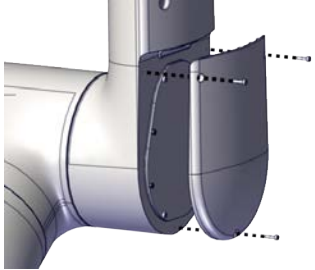
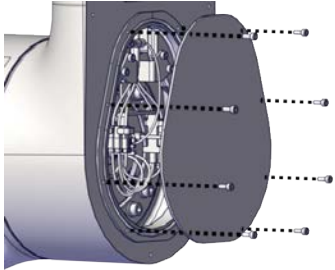
	Action	Note
1	 CAUTION Make sure that all supplies for electrical power are turned off.	
2	Remove the lower cover of lower arm by removing the screws.	 xx2300000812
3	Remove the lower inner cover by removing the screws.	 xx2300000813

Disconnecting the cabling between the lower arm and the swing

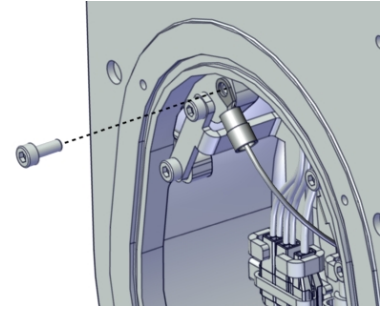
	Action	Note
1	Remove the functional earth cable by removing the screw.	 xx2000001936

Continues on next page

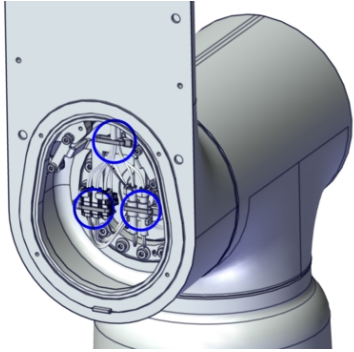
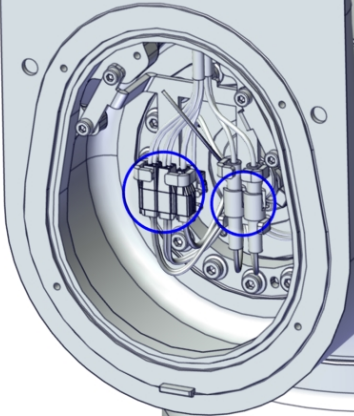
	Action	Note
2	Cut the cable ties.	 <p>xx2000001937</p>
3	Snap loose and disconnect all connectors.	 <p>xx2000001938</p>

Removing the lower and upper arm assembled

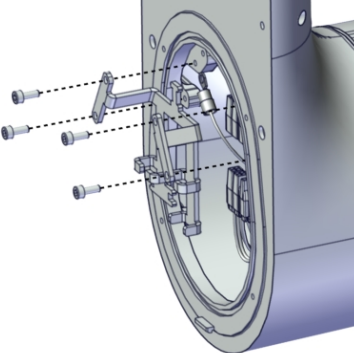
	Action	Note
1	Remove the cable bracket by removing the four screws.	 <p>xx2000001939</p>



5 Repair

5.5.1 Replacing the base

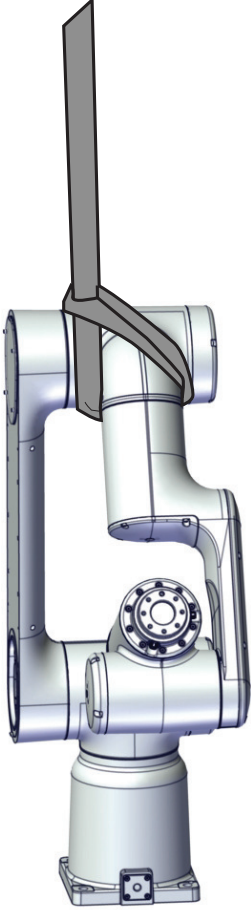
Continued

	Action	Note
2	<p>Secure the weight of the upper and lower arm.</p> <p> CAUTION</p> <p>The weight of the complete upper and lower arm together is up to 26 kg</p>	<p>Suggestion with lifting sling and an overhead crane.</p> <p>Example of CRB 15000-5/0.95, similar to CRB 15000-10/1.52 and CRB 15000-12/1.27.</p>  <p>xx2100000294</p>

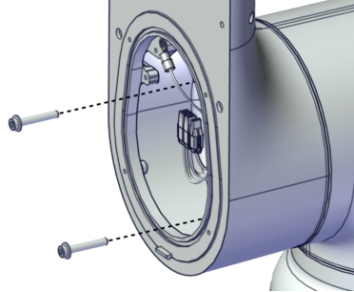
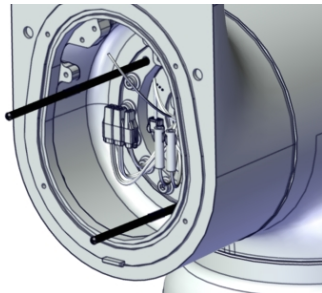
Continues on next page

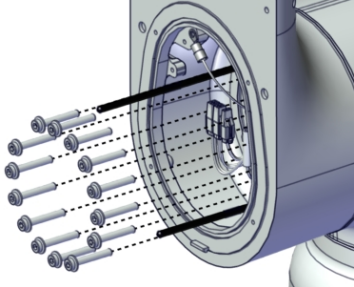
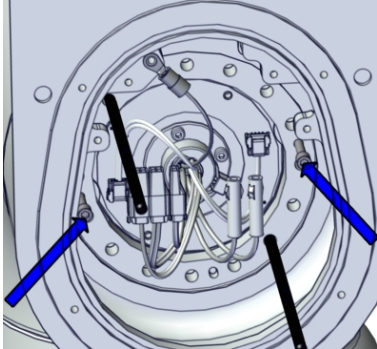
	Action	Note
3	<p>Remove two attachment screws and fit two guide pins to the axis-2 joint unit.</p> <p> CAUTION</p> <p>Do not mix the flange screws used for CRB 15000-5/0.95 and the threaded screws used for CRB 15000-10/1.52 and CRB 15000-12/1.27. Always use washers together with the threaded screws for CRB 15000-10/1.52 and CRB 15000-12/1.27. Illustration is for reference only.</p>	<p>Guide pin, M5x125: 3HAC087786-001</p> <p>Always use guide pins in pairs.</p>  <p>xx2000001951</p>  <p>xx2000001960</p>
4	<p>Remove the lower arm attachment screws.</p> <p> CAUTION</p> <p>Do not mix the flange screws used for CRB 15000-5/0.95 and the threaded screws used for CRB 15000-10/1.52 and CRB 15000-12/1.27. Always use washers together with the threaded screws for CRB 15000-10/1.52 and CRB 15000-12/1.27. Illustration is for reference only.</p>	 <p>xx2000001940</p>
5	<p>Use two fully threaded attachment screws as removal tools to press the lower arm out of position.</p>	 <p>xx2000002151</p>

Continues on next page

5 Repair

5.5.1 Replacing the base

Continued

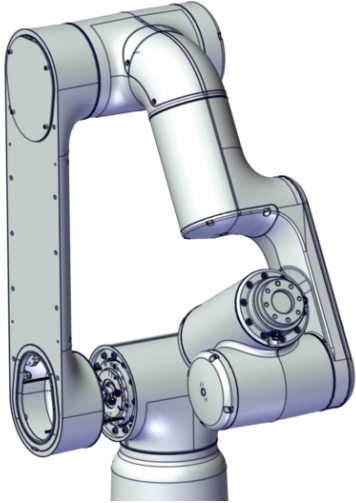
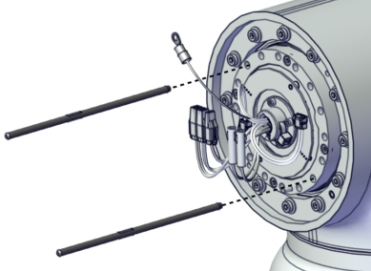
	Action	Note
6	Remove the complete arm system from the swing.	 xx2000001941
7	Remove the guide pins.	 xx2000002432

Removing the swing cover and insert (-10/1.52 and -12/1.27)

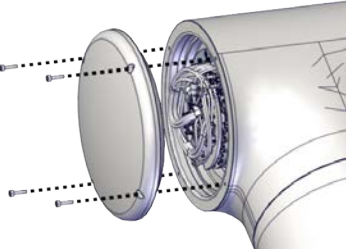
	Action	Note
1	 CAUTION Make sure that all supplies for electrical power are turned off.	
2	Remove the cover by removing the screws.	 xx2300000814

Continues on next page

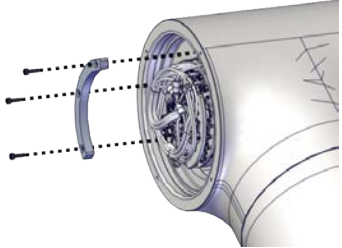
	Action	Note
3	<p> CAUTION</p> <p>Valid for CRB 15000-5/0.95</p> <p>There is cabling connected between the cover and the joint unit drive board.</p> <p>Open the cover with care to avoid damage to the cabling or the connector(s).</p> <p>Do not leave the cover in location without being secured with the attachment screws.</p>	
4	Remove the insert.	 <p>xx2300000815</p>

Disconnecting the axis-2 joint unit cabling

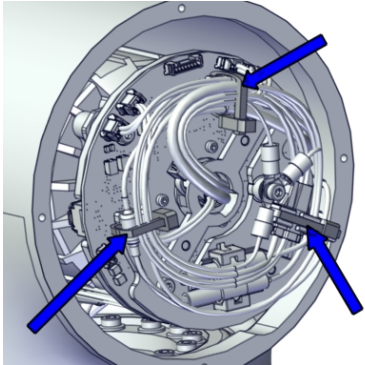

	Action	Note
1	<p> ELECTROSTATIC DISCHARGE (ESD)</p> <p>The unit is sensitive to ESD. Before handling the unit read the safety information in section The unit is sensitive to ESD on page 53.</p>	
2	Cut the cable ties.	 <p>xx2000001946</p>

Continues on next page

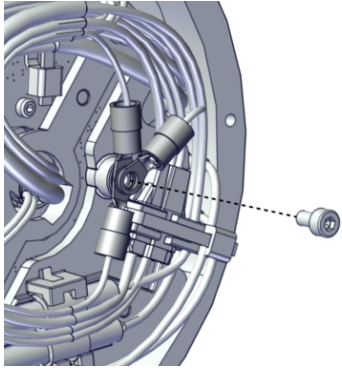
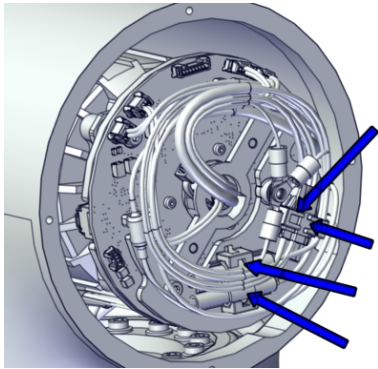

5 Repair

5.5.1 Replacing the base

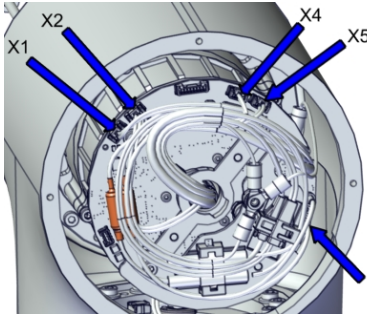

Continued

	Action	Note
3	Remove the functional and protective earth cables by removing the screw.	 xx2000001945
4	Snap loose and disconnect the connectors: <ul style="list-style-type: none"> • J2.DC+ • J2.DC- • J2.CS • J2.CP 	 xx2000001944
5	Disconnect the connectors from the drive board. <ul style="list-style-type: none"> • D2.X1 from X1 • D2.DC+ from DC+ • D2.DC- from ground • D2.X4 from X4 • D2.X2 from X2 • D2.X5 from X5  CAUTION Use tweezers to unlock connectors and pull them off.	 xx2000002013

Removing the base from foundation (-10/1.52 and -12/1.27)

	Action	Note
1	 CAUTION The weight of the complete swing and base together is up to 25 kg	
2	 WARNING Personnel must not, under any circumstances, be present under the suspended load.	

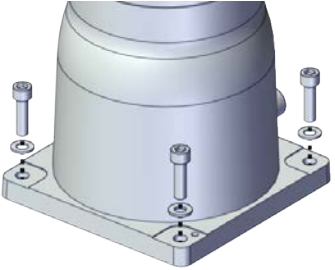
Continues on next page

	Action	Note
3	Loosen the robot base from the foundation by removing the foundation attachment screws.	 <p>xx2300001060</p>
4	Lay the robot down with the torque sensor side upwards on a working bench. Do not damage the base socket. Caution with the cabling.  CAUTION The cabling is sensitive to mechanical damage. Handle it with care to avoid damage to the cabling or the connector, avoid any kind of tilt or skew.	

Removing the axis-2 joint unit

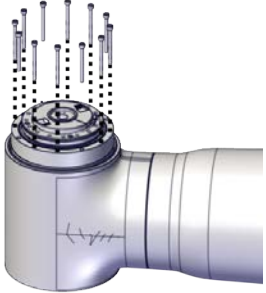



	Action	Note
1	Removing the attachment screws.	 <p>xx2300000786</p>

Continues on next page

5 Repair

5.5.1 Replacing the base

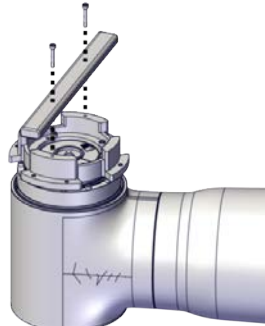
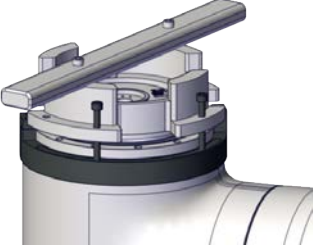
Continued

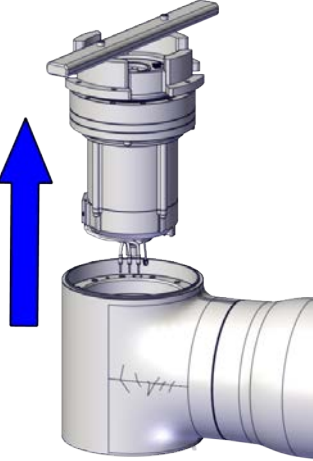
	Action	Note
2	<p>Fit the lifting aid to the joint unit, on the torque sensor side.</p> <p> CAUTION</p> <p>The connectors and the joint unit cables are sensitive to mechanical damage. Handle the assembly with care.</p>	<p>Lifting aid: 3HAC087787-001 Screws: M5x30 (4 pcs for plate and 2 pcs for beam)</p>  <p>xx2300000787</p>  <p>xx2300000788</p>
3	<p>Place the two semicircular blocks surrounding the joint unit, and use two fully threaded attachment screws as removal tools to press the joint unit out of position.</p>	 <p>xx2300000789</p>
4	<p>Remove the joint unit from the swing.</p> <p> CAUTION</p> <p>The connectors and the joint unit cables are sensitive to mechanical damage. Handle the assembly with care.</p>	 <p>xx2300000790</p>

Continues on next page

	Action	Note
5	Remove the lifting aid.	 <p data-bbox="1059 645 1166 667">xx2300000778</p> <p data-bbox="1059 1021 1166 1043">xx2300000776</p>

Securing the base (-10/1.52 and -12/1.27)

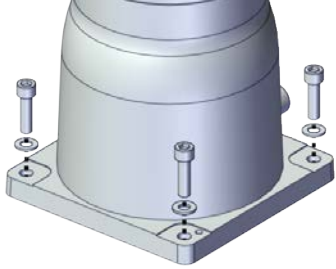
	Action	Note
1	Lift the base to standing and secure it to the foundation with the attachment screws and washers.	<p data-bbox="1023 1193 1406 1249">Attachment screws: M10x35 8.8 (4 pcs).</p> <p data-bbox="1023 1252 1437 1285">Washers: 23/10.5/2.5 mm Steel (4 pcs).</p> <p data-bbox="1023 1288 1382 1321">Tightening torque: 32 Nm \pm10%.</p>  <p data-bbox="1023 1621 1129 1644">xx2300001060</p>



Continues on next page

5 Repair

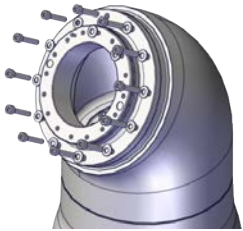

5.5.1 Replacing the base

Continued

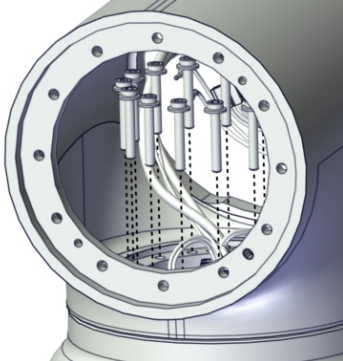
Removing the swing (-10/1.52 and -12/1.27)

	Action	Note
1	<p>Valid for CRB 15000-10/1.52 Remove the swing transition.</p>	 <p>xx2300000817</p>
2	<p>Valid for CRB 15000-10/1.52 Remove the swing flange.</p>	 <p>xx2300000818</p>
3	<p>Remove the swing attachment screws.</p> <p> CAUTION</p> <p>Do not mix the flange screws used for CRB 15000-5/0.95 and the threaded screws used for CRB 15000-10/1.52 and CRB 15000-12/1.27. Always use washers together with the threaded screws for CRB 15000-10/1.52 and CRB 15000-12/1.27. Illustration is for reference only.</p>	<p>Valid for CRB 15000-10/1.52</p>  <p>xx2300000819</p> <p>Valid for CRB 15000-12/1.27</p>  <p>xx2000001987</p>

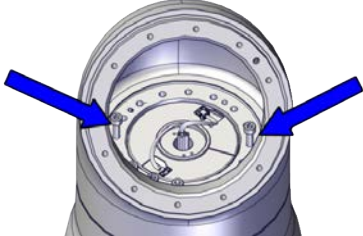
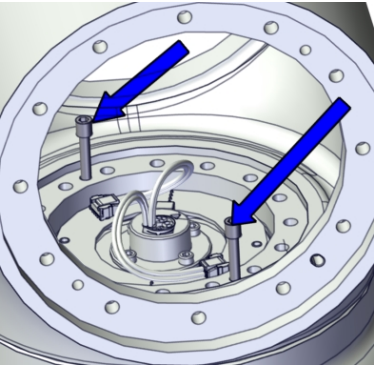
Continues on next page

	Action	Note
4	<p>Use two fully threaded attachment screws as removal tools to press the swing out of position.</p> <p> CAUTION</p> <p>Do not mix the flange screws used for CRB 15000-5/0.95 and the threaded screws used for CRB 15000-10/1.52 and CRB 15000-12/1.27. Always use washers together with the threaded screws for CRB 15000-10/1.52 and CRB 15000-12/1.27. Illustration is for reference only.</p>	<p>Valid for CRB 15000-10/1.52</p>  <p>xx2300000822</p> <p>Valid for CRB 15000-12/1.27</p>  <p>xx2000002152</p>
5	<p>Lift away the swing.</p> <p> CAUTION</p> <p>The torque sensor (on the exposed PCBA) is sensitive to mechanical damage. Handle the assembly with care.</p>	

Loosening the base and removing the base cover

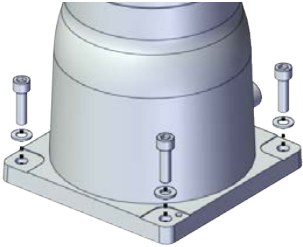
	Action	Note
1	<p>Loosen the base from the foundation by removing the attachment screws and washers.</p>	 <p>xx2300001060</p>

Continues on next page

5 Repair

5.5.1 Replacing the base

Continued

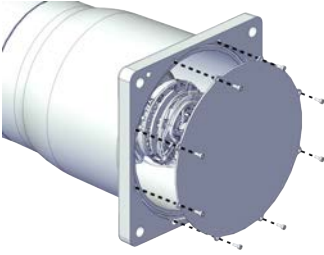
	Action	Note
2	Tilt the base on to its side and remove the bottom cover by removing the attachment screws.	 <p data-bbox="1029 584 1136 607">xx2300000760</p>

Disconnecting the axis-1 joint unit cabling

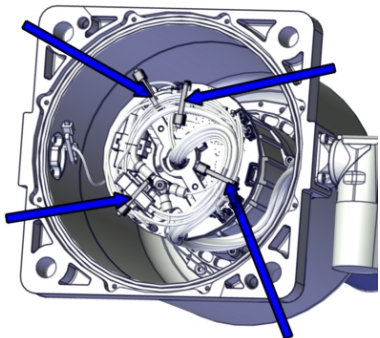
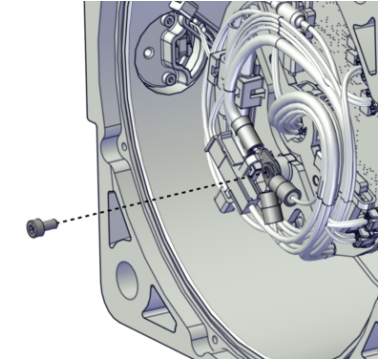
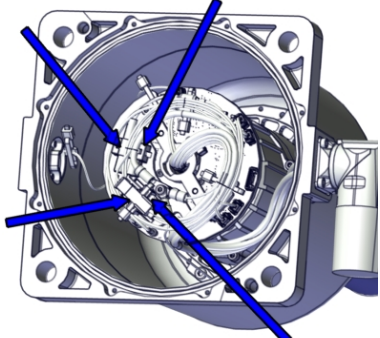
	Action	Note
1	Cut the cable ties.	 <p data-bbox="1029 1115 1136 1137">xx2000002012</p>
2	Remove the functional and protective earth cables by removing the screw.	 <p data-bbox="1029 1532 1136 1554">xx2000002011</p>
3	Snap loose and disconnect the connectors: <ul style="list-style-type: none"> • J1.DC+ • J1.DC- • J1.CS • J1.CP 	 <p data-bbox="1029 1944 1136 1966">xx2000002010</p>

Continues on next page

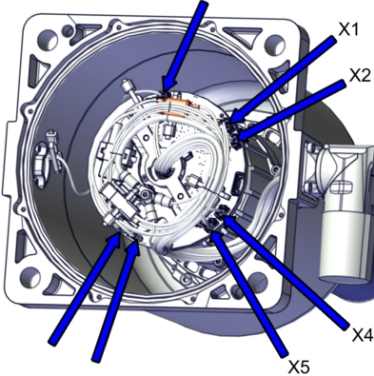
	Action	Note
4	<p>Disconnect the connectors from the drive board.</p> <ul style="list-style-type: none"> • D1.X1 from X1 • D1.DC+ from DC+ • D1.DC- from ground • D1.X4 from X4 • D1.X2 from X2 • D1.X5 from X5 • DR.X8 from X8 <p> CAUTION</p> <p>Use tweezers to unlock connectors and pull them off.</p>	 <p>xx2000002009</p>

Removing the axis-1 joint unit (-10/1.52 and -12/1.27)





	Action	Note
1	<p>Removing the attachment screws.</p>	 <p>xx2300000770</p>

Continues on next page

5 Repair

5.5.1 Replacing the base

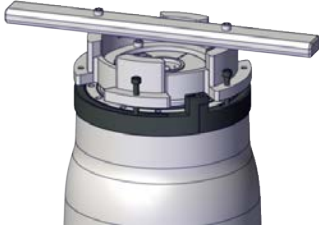
Continued

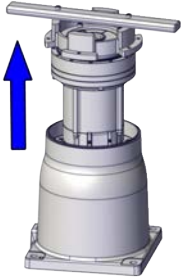
	Action	Note
2	<p>Fit the lifting aid to the joint unit, on the torque sensor side.</p> <p> CAUTION</p> <p>The connectors and the joint unit cables are sensitive to mechanical damage. Handle the assembly with care.</p>	<p>Lifting aid: 3HAC087787-001 Screws: M5x30 (4 pcs for plate and 2 pcs for beam)</p>  <p>xx2300000771</p>  <p>xx2300000772</p>
3	<p>Place the two semicircular blocks surrounding the joint unit, and use two fully threaded attachment screws as removal tools to press the joint unit out of position.</p>	 <p>xx2300000773</p>
4	<p>Remove the joint unit from the swing.</p> <p> CAUTION</p> <p>The connectors and the joint unit cables are sensitive to mechanical damage. Handle the assembly with care.</p>	 <p>xx2300000774</p>

Continues on next page

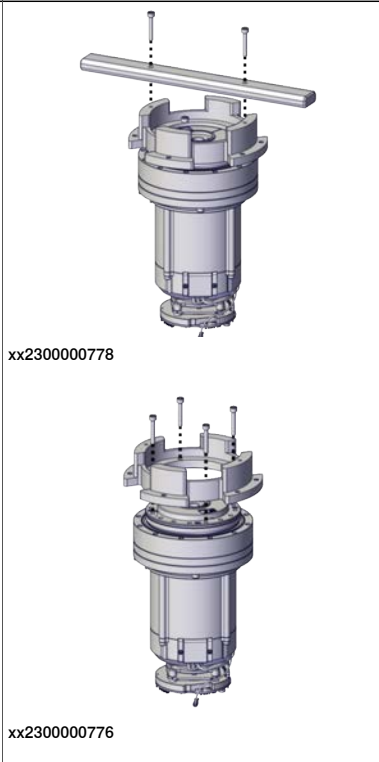
	Action	Note
5	Remove the lifting aid.	 <p>xx2300000778</p> <p>xx2300000776</p>

Removing the base cabling

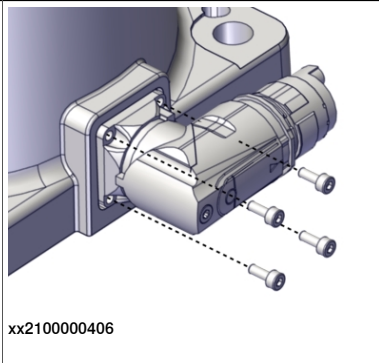
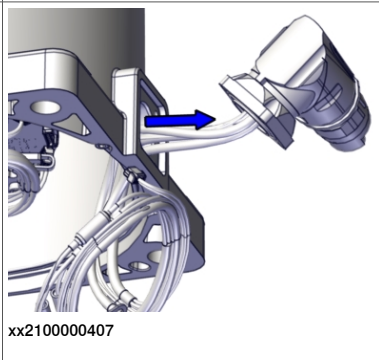
	Action	Note
1	Remove the attachment screws.	 <p>xx2100000406</p>
2	Pull out the cabling from the base.	 <p>xx2100000407</p>

Continues on next page

5 Repair

5.5.1 Replacing the base

Continued

Refitting the base (-5/0.95)

Use these procedures to refit the base.

Refitting the brake release unit

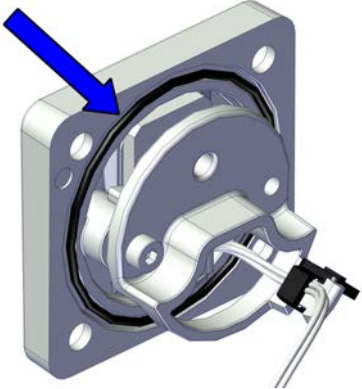
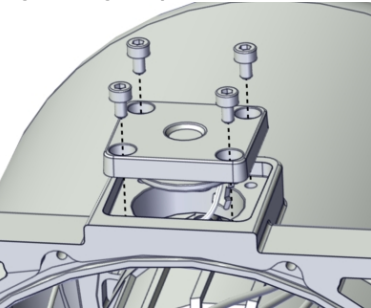
	Action	Note
1	Wipe, lubricate and fit the o-ring to its groove. Replace if damaged.	<p>O-ring: 3HAB3772-119 Grease: 3HAC031695-001 Harmonic Grease 4B No.2 Used to lubricate the seals.</p>  <p>xx2100000423</p>
2	Refit the brake release unit to the new base with the screws.	<p>Base: 3HAC073922-001 Screws: M3x5 12.9 Lafre 2C2B/FC6.9 (4 pcs) Tightening torque: 0.45 Nm.</p>  <p>xx2100000413</p>

Refitting the base cabling

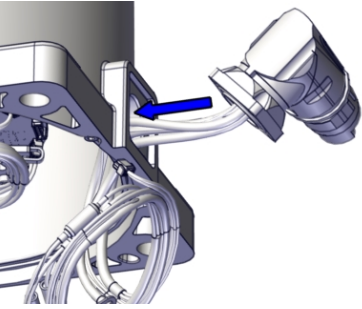
	Action	Note
1	Insert the cabling into the base.	 <p>xx2100000408</p>

Continues on next page

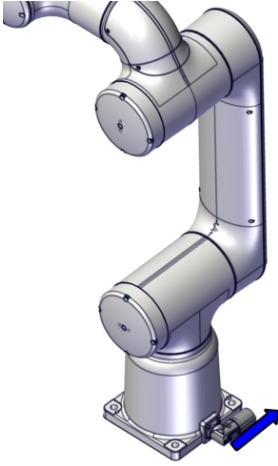
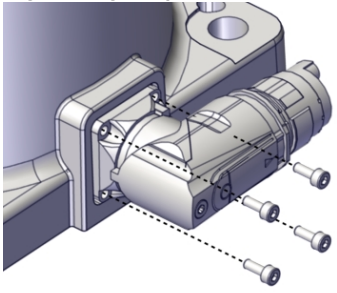
	Action	Note
2	Orient the base connector so that it points to the right, seen from back of the robot.	 <p>xx2100000409</p>
3	Secure the base connector with the attachment screws.	<p>Hex socket head cap screw: M3x8 12.9 Lafre 2C2B/FC6.9 (4 pcs). Tightening torque: 0.8 Nm.</p>  <p>xx2100000406</p>

Preparations before fitting the joint unit (-5/0.95)



	Action	Note
1	 <p>ELECTROSTATIC DISCHARGE (ESD)</p> <p>The unit is sensitive to ESD. Before handling the unit read the safety information in section The unit is sensitive to ESD on page 53.</p>	

Continues on next page



5 Repair

5.5.1 Replacing the base

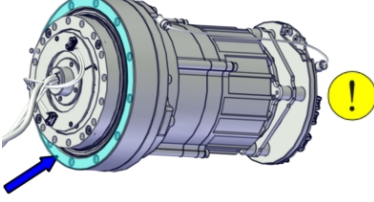

Continued

	Action	Note
2	Clean the mounting surface of the joint unit and the mating surface on the casting with isopropanol. Joint unit mounting surface is pointed out in the figure.	Cleaning agent: Isopropanol Flange sealant: Loctite 574
3	Apply a thin layer of flange sealant to the mounting surface. Do not contaminate the radial sealing with sealant.  CAUTION The connectors and the joint unit cables are sensitive to mechanical damage. Handle the assembly with care.  ELECTROSTATIC DISCHARGE (ESD) The unit is sensitive to ESD. Before handling the unit read the safety information in section The unit is sensitive to ESD on page 53 .	 xx2000001860

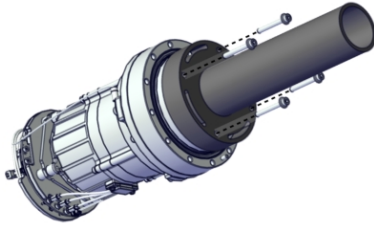
Refitting the axis-1 joint unit (-5/0.95)

	Action	Note
1	 ELECTROSTATIC DISCHARGE (ESD) The unit is sensitive to ESD. Before handling the unit read the safety information in section The unit is sensitive to ESD on page 53 .	
2	Fit the lifting aid to the joint unit.  CAUTION The connectors and the joint unit cables are sensitive to mechanical damage. Handle the assembly with care.	Joint unit: 3HAC079141-001 Lifting aid: 3HAC077788-001 Screws: M4x35 (4 pcs)  xx2000001957

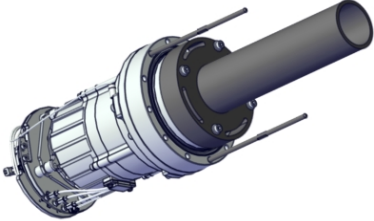
Continues on next page

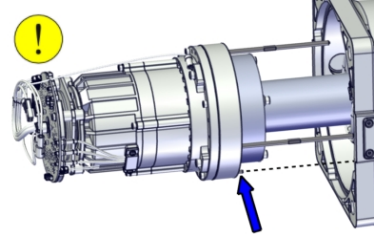
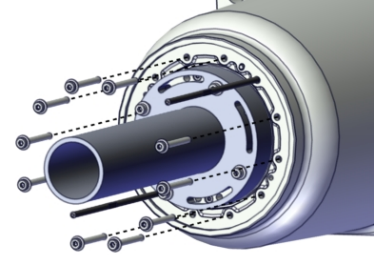
	Action	Note
3	Fit two guide pins to the joint unit.	<p>Guide pin, M4x120: 3HAC077786-001</p> <p>Always use guide pins in pairs.</p> <p>For joint units on axes 1, 2 and 3 of CRB 15000-5/0.95 and axis 3 of CRB 15000-10/1.52 and CRB 15000-12/1.27.</p>  <p>xx2000002438</p>
4	<p>Fit the joint unit to the base, aligning the pin with the pin hole.</p> <p> CAUTION</p> <p>The connectors and the joint unit cables are sensitive to mechanical damage. Handle the assembly with care.</p>	 <p>xx2000002015</p>
5	Secure the joint unit with new attachment screws.	<p>Flange socket head screw with glue: 3HAB3413-435</p> <p>M4x35 12.9 Lafre 2C2B/FC6.9+PrO-COat111, with NYPLAS glue , 12 pcs</p> <p>Used for joint unit of CRB 15000-5/0.95.</p> <p>Always use new screws when refitting a joint unit. If ordering a new joint unit spare part, new screws are included.</p>  <p>xx2000002008</p>

Continues on next page

5 Repair

5.5.1 Replacing the base

Continued

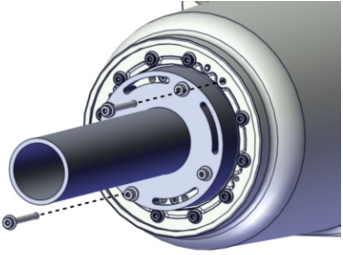
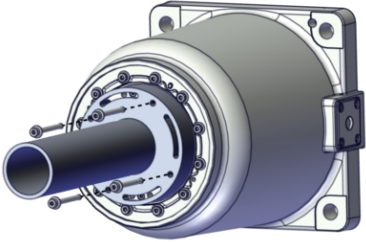
	Action	Note
6	Remove the guide pins and secure the remaining two attachment screws.	 xx2100000296
7	Pre-tighten the screws crosswise.	
8	Torque tighten all screws crosswise.	Tightening torque: 4.3 Nm.
9	Remove the lifting aid by removing the screws.	 xx2000001994
10	Clean pushed-out flange sealant, if any.	

Connecting the axis-1 joint unit cabling

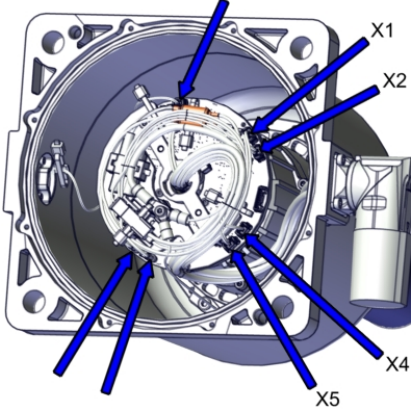
	Action	Note
1	 ELECTROSTATIC DISCHARGE (ESD) The unit is sensitive to ESD. Before handling the unit read the safety information in section The unit is sensitive to ESD on page 53 .	
2	Reconnect the connectors to the drive board. <ul style="list-style-type: none"> • D1.X1 to X1 • D1.DC+ to DC+ • D1.DC- to Ground • D1.X4 to X4 • D1.X2 to X2 • D1.X5 to X5 • DR.X8 to X8 	 xx2000002009

Continues on next page

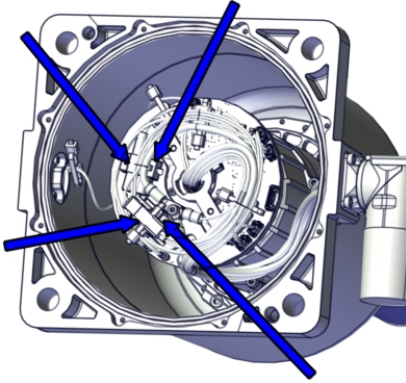
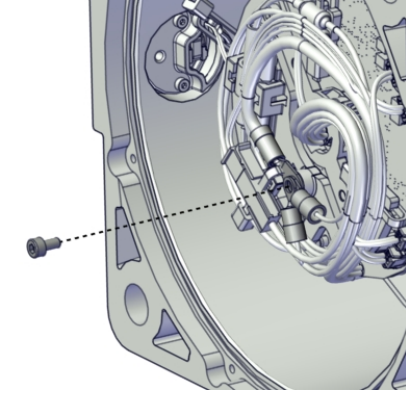
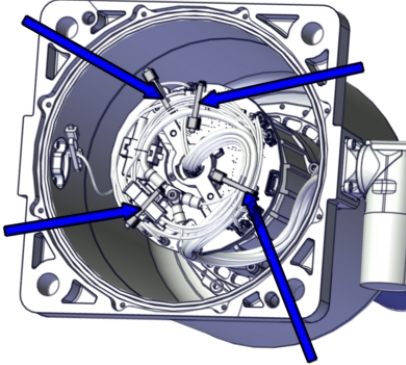
	Action	Note
3	<p>Connect the connectors to each other and snap them to the cable holders.</p> <ul style="list-style-type: none"> • J1.DC+ to J1.DC+ • J1.DC- to J1.DC- • J1.CS to J1.CS • J1.CP to J1.CP 	 <p>xx2000002010</p>
4	<p>Secure the cables for functional earth and protective earth with a screw.</p>	<p>Hex socket head cap screw: M3x6 (1 pcs). Tightening torque: 0.8 Nm.</p>  <p>xx2000002011</p>
5	<p>Secure the cabling with cable ties.</p>	<p>Cable ties (4 pcs)</p>  <p>xx2000002012</p>



Continues on next page

5 Repair

5.5.1 Replacing the base

Continued

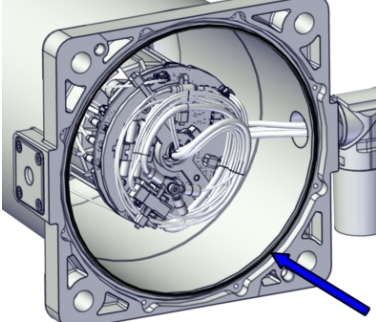
Refitting the base cover (-5/0.95)

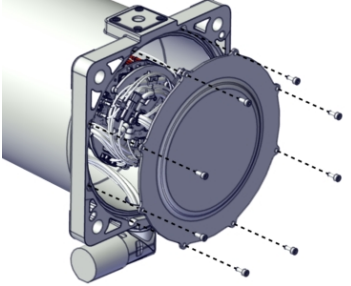
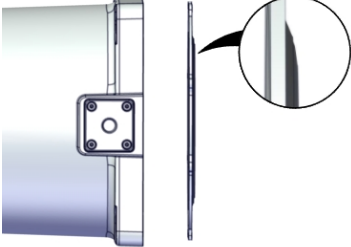
	Action	Note
1	<p>Wipe, lubricate and fit the o-ring to its groove. Replace if damaged.</p>	<p>O-ring: 3HAB3772-64 Grease: 3HAC042536-001 (Shell Gadus S2)</p>  <p>xx2000002016</p>
2	<p>Refit the bottom cover with the attachment screws.</p> <p> Note</p> <p>For CRB 15000-5/0.95, fit the cover in correct direction, the protrusion of the cover must face outwards.</p>	<p>Hex socket head cap screw: M3x8 12.9 Lafre 2C2B/FC6.9 (8 pcs) Tightening torque: 1.2 Nm.</p>  <p>xx2000002007</p>  <p>xx2100000268</p>

Continues on next page

Securing the base

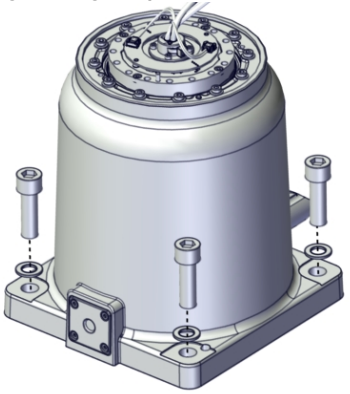
	Action	Note
1	Lift the base to standing and secure it to the foundation with the attachment screws and washers.	<p>Attachment screws: M10x35 8.8 (4 pcs). Washers: 23/10.5/2.5 mm Steel (4 pcs). Tightening torque: 32 Nm ±10%.</p>  <p>xx2000002006</p>

Refitting the swing(-5/0.95)

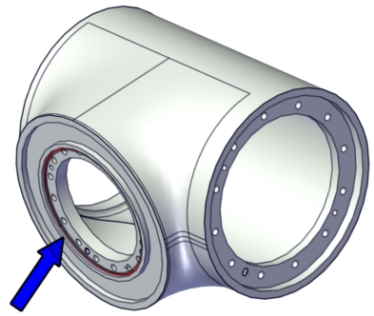

	Action	Note
1	Clean the mounting surface with isopropanol. Apply flange sealant to the corner of the base mounting surface, as pointed out in the figure.	<p>Cleaning agent: Isopropanol Flange sealant: Loctite 574</p>  <p>xx2000001990</p>
2	Separate the new swing parts by removing the pre-assembling screws.	

Continues on next page

5 Repair

5.5.1 Replacing the base

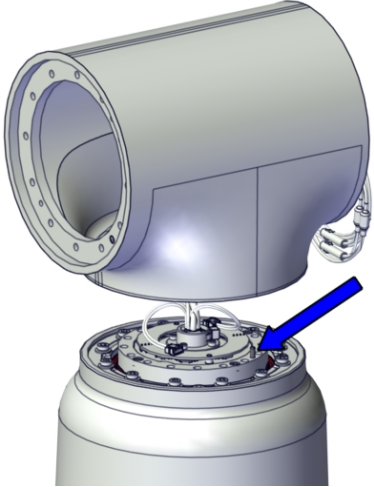

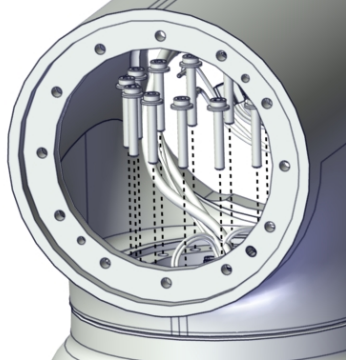
Continued

	Action	Note
3	<p>Refit the swing to the base unit, aligning the pin with the pin hole.</p> <p> CAUTION</p> <p>The torque sensor (on the exposed PCBA) is sensitive to mechanical damage. Handle the assembly with care.</p>	 <p>xx2000001989</p>
4	<p>Secure the swing with the attachment screws. Pre-tighten the screws crosswise firstly.</p> <p> CAUTION</p> <p>Do not mix the flange screws used for CRB 15000-5/0.95 and the threaded screws used for CRB 15000-10/1.52 and CRB 15000-12/1.27. Always use washers together with the threaded screws for CRB 15000-10/1.52 and CRB 15000-12/1.27. Illustration is for reference only.</p>	<p>Hex socket head cap flange screw: M4x25 12.9 Lafre 2C2B/FC6.9+PrO-COat111 (16 pcs)</p>  <p>xx2000001987</p>
5	<p>Torque tighten all screws crosswise.</p>	<p>Tightening torque: 4.6 Nm</p>



Preparations before fitting the joint unit (-5/0.95)

	Action	Note
1	<p> ELECTROSTATIC DISCHARGE (ESD)</p> <p>The unit is sensitive to ESD. Before handling the unit read the safety information in section The unit is sensitive to ESD on page 53.</p>	

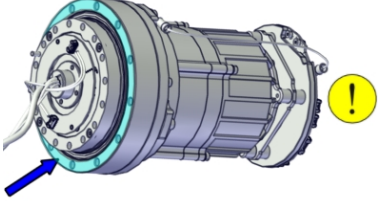
Continues on next page

	Action	Note
2	Clean the mounting surface of the joint unit and the mating surface on the casting with isopropanol. Joint unit mounting surface is pointed out in the figure.	Cleaning agent: Isopropanol Flange sealant: Loctite 574
3	Apply a thin layer of flange sealant to the mounting surface. Do not contaminate the radial sealing with sealant.  CAUTION The connectors and the joint unit cables are sensitive to mechanical damage. Handle the assembly with care.  ELECTROSTATIC DISCHARGE (ESD) The unit is sensitive to ESD. Before handling the unit read the safety information in section The unit is sensitive to ESD on page 53 .	 xx2000001860

Refitting the axis-2 joint unit (-5/0.95)

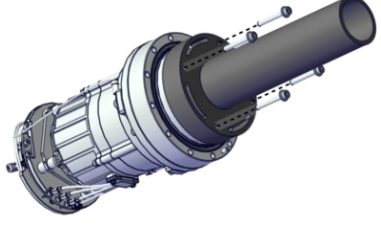





	Action	Note
1	 ELECTROSTATIC DISCHARGE (ESD) The unit is sensitive to ESD. Before handling the unit read the safety information in section The unit is sensitive to ESD on page 53 .	
2	Fit the lifting aid to the joint unit.  CAUTION The connectors and the joint unit cables are sensitive to mechanical damage. Handle the assembly with care.	Joint unit: 3HAC079141-001 Lifting aid: 3HAC077788-001 Screws: M4x35 (4 pcs)  xx2000001957

Continues on next page

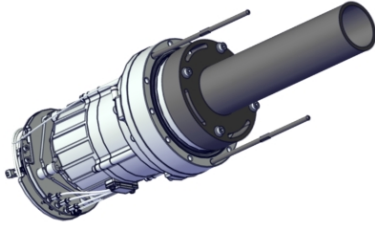
5 Repair

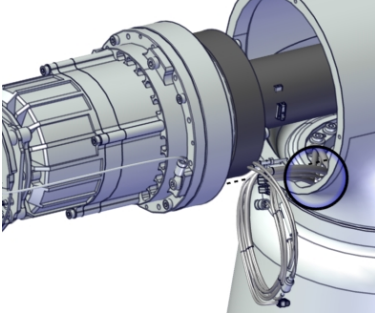
5.5.1 Replacing the base

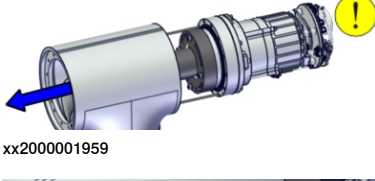
Continued

	Action	Note
3	Fit two guide pins to the joint unit.	<p>Guide pin, M4x120: 3HAC077786-001</p> <p>Always use guide pins in pairs.</p> <p>For joint units on axes 1, 2 and 3 of CRB 15000-5/0.95 and axis 3 of CRB 15000-10/1.52 and CRB 15000-12/1.27.</p>  <p>xx2000002438</p>
4	<p>Place the axis-1 cabling at the notch in the swing.</p> <p> CAUTION</p> <p>The cabling is sensitive to mechanical damage. Handle it with care to avoid damage to the cabling or the connector, avoid any kind of tilt or skew.</p>	 <p>xx2000002153</p>
5	<p>Fit the joint unit to the swing, aligning the pin with the pin hole.</p> <p> CAUTION</p> <p>The connectors and the joint unit cables are sensitive to mechanical damage. Handle the assembly with care.</p>	 <p>xx2000001959</p>  <p>xx2000001961</p>

Continues on next page

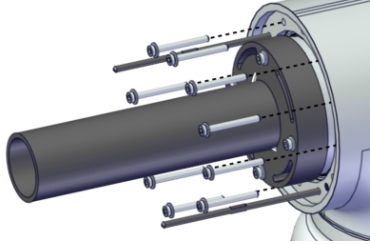
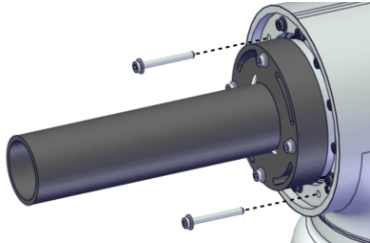
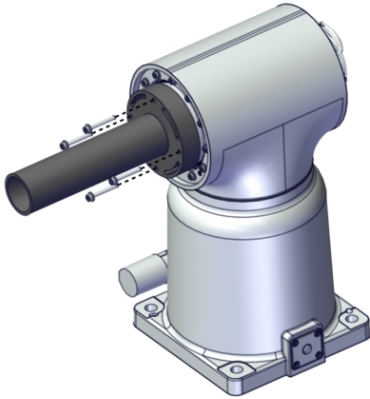
	Action	Note
6	Secure the joint unit with new attachment screws.	<p>Flange socket head screw with glue: 3HAB3413-435 M4x35 12.9 Lafre 2C2B/FC6.9+PrO-COat111, with NYPLAS glue , 12 pcs Used for joint unit of CRB 15000-5/0.95. Always use new screws when refitting a joint unit. If ordering a new joint unit spare part, new screws are included.</p>  <p>xx2000001943</p>
7	Remove the guide pins and secure the remaining two attachment screws.	 <p>xx2100000295</p>
8	Pre-tighten the screws crosswise.	
9	Torque tighten all screws crosswise.	Tightening torque: 4.3 Nm.
10	Remove the lifting aid by removing the screws.	 <p>xx2000001956</p>
11	Clean pushed-out flange sealant, if any.	



Continues on next page

5 Repair

5.5.1 Replacing the base

Continued

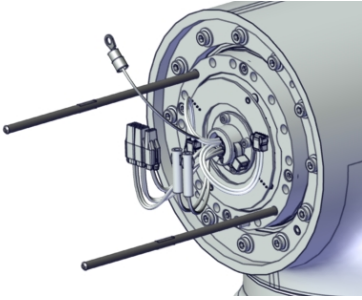
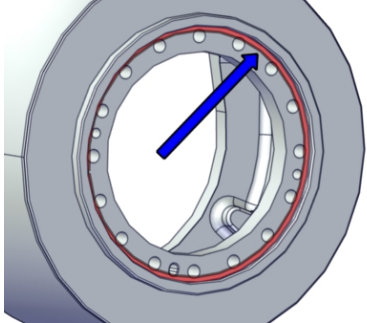
Refitting the lower and upper arm assembled (-5/0.95)

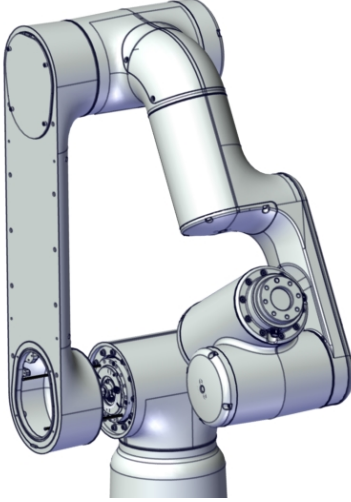
	Action	Note
1	Fit two guide pins to the axis-2 joint unit.	<p>Guide pin, M4x120: 3HAC077786-001</p>  <p>xx2000001949</p>
2	<p>Remove any old residuals of flange sealant from the lower arm mounting surface and clean with isopropanol.</p> <p>Apply new flange sealant to the corner of the lower arm mounting surface, as pointed out in the figure.</p>	<p>Cleaning agent: Isopropanol Flange sealant: Loctite 574</p>  <p>xx2000001963</p>
3	<p> CAUTION</p> <p>The weight of the complete upper and lower arm together is 18 kg</p>	
4	Lift the upper and lower arm assembly to mounting position and slide it onto the guide pins.	 <p>xx2000001941</p>

Continues on next page

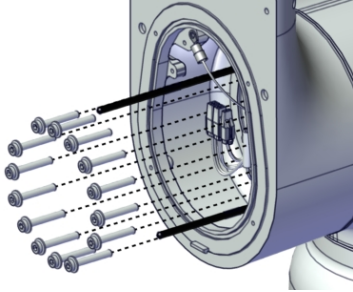
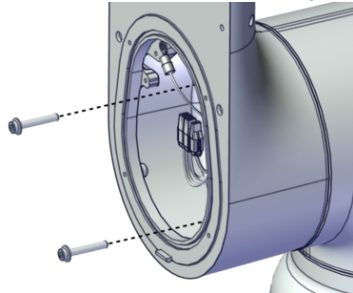
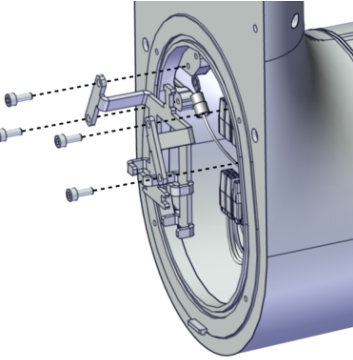
	Action	Note
5	<p>Secure the lower arm to the swing with all attachment screws but two. Pre-tighten the screws crosswise firstly.</p> <p>! CAUTION</p> <p>Do not mix the flange screws used for CRB 15000-5/0.95 and the threaded screws used for CRB 15000-10/1.52 and CRB 15000-12/1.27. Always use washers together with the threaded screws for CRB 15000-10/1.52 and CRB 15000-12/1.27. Illustration is for reference only.</p>	<p>Hex socket head cap flange screw: M4x25 12.9 Lafre 2C2B/FC6.9+PrO-COat111 (16 pcs)</p>  <p>xx2000001940</p>
6	<p>Remove the guide pins and fasten the remaining two screws.</p> <p>! CAUTION</p> <p>Do not mix the flange screws used for CRB 15000-5/0.95 and the threaded screws used for CRB 15000-10/1.52 and CRB 15000-12/1.27. Always use washers together with the threaded screws for CRB 15000-10/1.52 and CRB 15000-12/1.27. Illustration is for reference only.</p>	<p>Hex socket head cap flange screw: M4x25 12.9 Lafre 2C2B/FC6.9+PrO-COat111 (16 pcs)</p>  <p>xx2000001951</p>
7	<p>Torque tighten all screws crosswise.</p>	<p>Tightening torque: 4.6 Nm</p>
8	<p>Refit the cable bracket with four screws.</p>	<p>Hex socket head cap screw: M3x8 12.9 Lafre 2C2B/FC6.9 (4 pcs). Tightening torque: 0.8 Nm</p>  <p>xx2000001939</p>

Continues on next page

5 Repair

5.5.1 Replacing the base

Continued

Connecting the axis-2 joint unit cabling

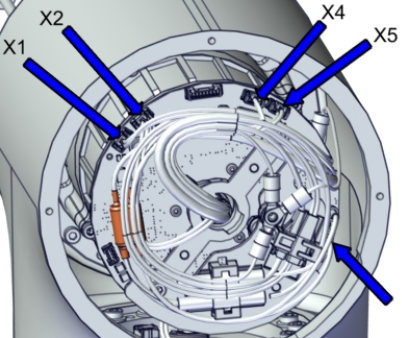
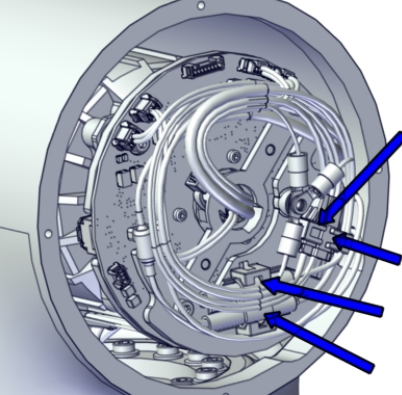
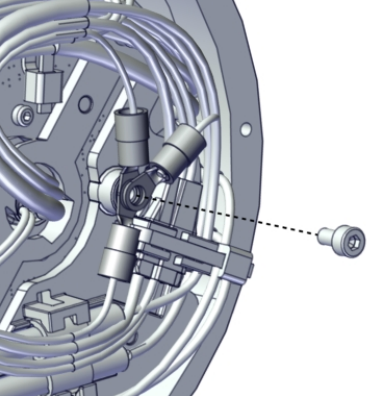
	Action	Note
1	 ELECTROSTATIC DISCHARGE (ESD) The unit is sensitive to ESD. Before handling the unit read the safety information in section <i>The unit is sensitive to ESD on page 53.</i>	
2	Reconnect the connectors to the drive board. <ul style="list-style-type: none"> • D2.X1 to X1 • D2.DC+ to DC+ • D2.DC- to Ground • D2.X4 to X4 • D2.X2 to X2 • D2.X5 to X5 	 <p>xx2000002013</p>
3	Connect the connectors to each other and snap them to the cable holders. <ul style="list-style-type: none"> • J2.DC+ to J2.DC+ • J2.DC- to J2.DC- • J2.CS to J2.CS • J2.CP to J2.CP 	 <p>xx2000001944</p>
4	Secure the cables for functional earth and protective earth with a screw.	Hex socket head cap screw: M3x6 (1 pcs). Tightening torque: 0.8 Nm.  <p>xx2000001945</p>

Continues on next page

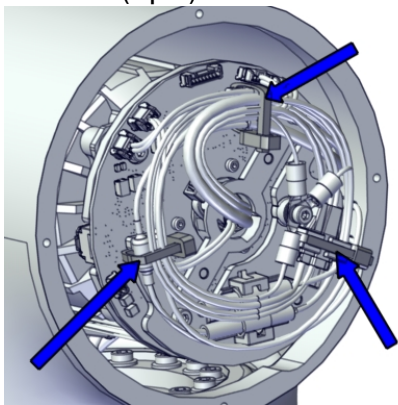
	Action	Note
5	Secure the cabling with cable ties.	Cable ties (3 pcs)  xx2000001946

Connecting the cabling between the lower arm and swing

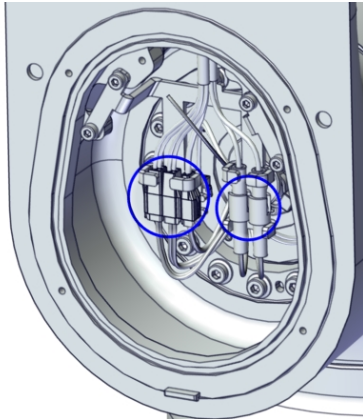
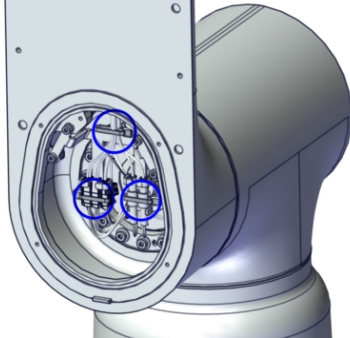
	Action	Note
1	Connect the connectors to each other and snap them to the cable holders.	 xx2000001938
2	Secure the cabling with cable ties.	Cable ties (3 pcs)  xx2000001937

Continues on next page

5 Repair

5.5.1 Replacing the base

Continued

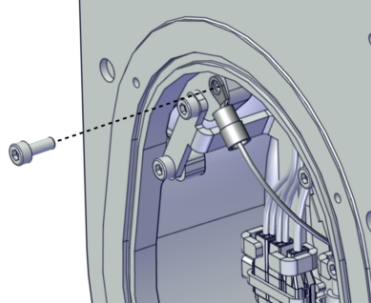
	Action	Note
3	Connect the functional earth cable with the screw.	<p>Hex socket head cap screw: M3x8 12.9 Lafre 2C2B/FC6.9 (1 pcs). Tightening torque: 0.8 Nm</p>  <p>xx2000001936</p>

Refitting the lower arm covers (-5/0.95)

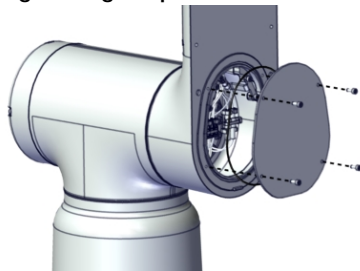
	Action	Note
1	Wipe, lubricate and fit the o-ring to its groove. Replace if damaged.	<p>O-ring: 3HAC061327-044 Grease: 3HAC042536-001 (Shell Gadus S2)</p>  <p>xx2000001954</p>
2	Refit the inner cover with four screws.	<p>Hex socket head cap screw: M3x8 12.9 Lafre 2C2B/FC6.9 (4 pcs) Tightening torque: 1.4 Nm.</p>  <p>xx2000001930</p>

Continues on next page

	Action	Note
3	Snap the lower arm cover into place.	Hex socket head cap screw: M3x16 12.9 Lafre 2C2B/FC6.9 (4 pcs) Tightening torque: 0.45 Nm.
4	Secure the cover with four screws.	

xx2000001929

Refitting the swing cover(-5/0.95)

	Action	Note
1	Fit the o-ring to cover groove. Replace if damaged.	O-ring: 3HAC061327-047 (for CRB 15000-5/0.95)
2	For robots with RobotWare earlier than 7.10 Place the cover at mounting position and reconnect the brake release connector DR.X8 to the drive board. Orient the cover for proper arrangement of the brake release cable.	

xx2000001962

xx2000001932

Continues on next page

5 Repair

5.5.1 Replacing the base

Continued

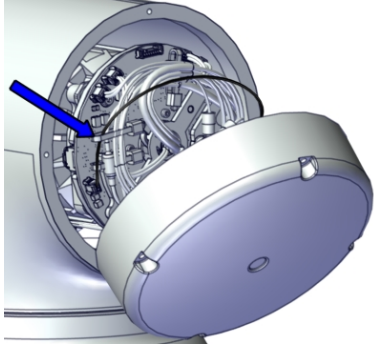
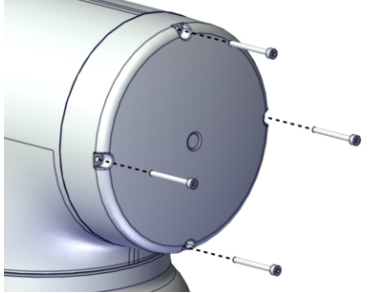
	Action	Note
3	For robots with RobotWare earlier than 7.10 Secure the brake release cable with a cable tie.	Cable ties  xx2000001931
4	Refit the cover with the four screws.	Hex socket head cap screw: M3x30 12.9 Lafre 2C2B/FC6.9 (4 pcs) Tightening torque: 0.45 Nm  xx2000001935

Concluding procedure

	Action	Note
1	Calibrate the joint unit torque sensor for the axis-1 and axis-2 joint units.	See Calibration on page 1063
2	 DANGER Make sure all safety requirements are met when performing the first test run. See Test run after installation, maintenance, or repair on page 90 .	

Continues on next page

Refitting the base (-10/1.52 and -12/1.27)

Use these procedures to refit the base.

Refitting the base cabling

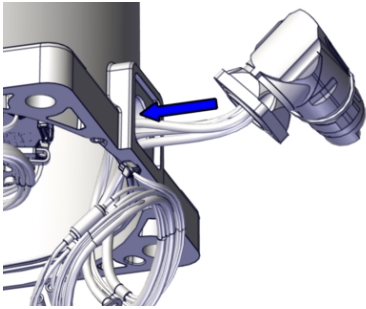
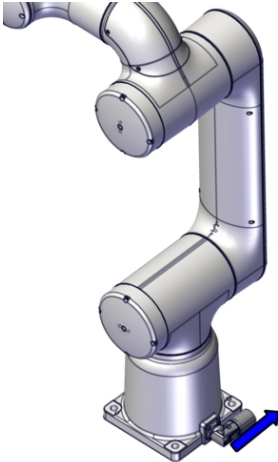
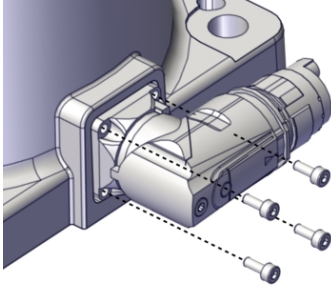
	Action	Note
1	Insert the cabling into the base.	 <p>xx2100000408</p>
2	Orient the base connector so that it points to the right, seen from back of the robot.	 <p>xx2100000409</p>
3	Secure the base connector with the attachment screws.	<p>Hex socket head cap screw: M3x8 12.9 Lafre 2C2B/FC6.9 (4 pcs). Tightening torque: 0.8 Nm.</p>  <p>xx2100000406</p>

Continues on next page

5 Repair



5.5.1 Replacing the base

Continued

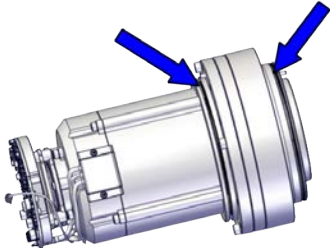
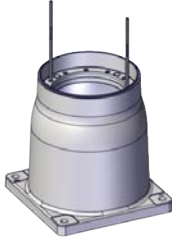
Refitting the axis-1 joint unit (-10/1.52 and -12/1.27)

	Action	Note
1	 ELECTROSTATIC DISCHARGE (ESD) The unit is sensitive to ESD. Before handling the unit read the safety information in section <i>The unit is sensitive to ESD on page 53</i> .	
2	Check the o-rings. Replace if damaged.	O-ring: 3HAC061327-044  xx2300000823
3	Fit two guide pins to the base.	Guide pin, M5x125: 3HAC087786-001 Always use guide pins in pairs. For joint units on axes 1 and 2 of CRB 15000-10/1.52 and CRB 15000-12/1.27.  xx2300000775

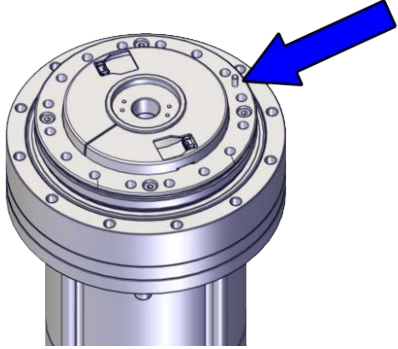
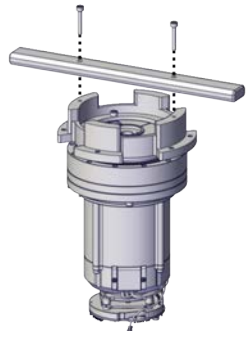
Continues on next page

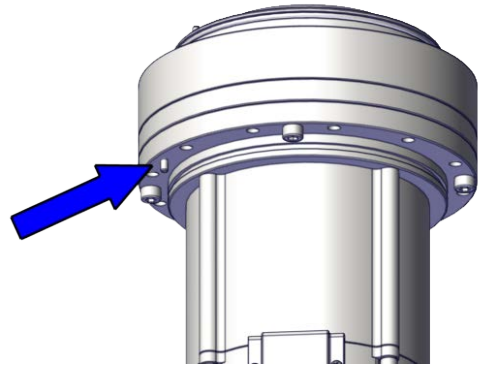
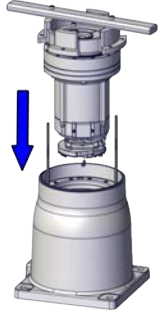



	Action	Note
4	<p>Fit the lifting aid to the joint unit, aligning the pin with the pin hole.</p> <p> CAUTION</p> <p>The connectors and the joint unit cables are sensitive to mechanical damage. Handle the assembly with care.</p>  <p>xx2300000777</p>	<p>Joint unit: 3HAC087472-001 Lifting aid: 3HAC087787-001 Screws: M5x30 (4 pcs for plate and 2 pcs for beam)</p>  <p>xx2300000778</p>  <p>xx2300000776</p>
5	<p>Fit the joint unit to the base, aligning the pin with the pin hole.</p> <p> CAUTION</p> <p>The connectors and the joint unit cables are sensitive to mechanical damage. Handle the assembly with care.</p>  <p>xx2300000780</p>	 <p>xx2300000779</p>

Continues on next page

5 Repair

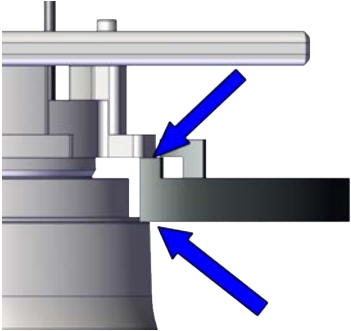
5.5.1 Replacing the base

Continued

	Action	Note
6	<p>Check the joint unit position by placing the lower boss of one semicircular block between the lifting aid and base.</p> <p>The joint unit is properly placed when no gaps between the block and both lifting aid and base</p>	 <p>xx2300000781</p>
7	<p>Remove the guide pins.</p>	 <p>xx2300000782</p>
8	<p>Secure with four attachment screws and pre-tighten the screws crosswise.</p>	 <p>xx2300000783</p>
9	<p>Remove the lifting aid by removing the screws.</p>	 <p>xx2300000784</p>

Continues on next page

	Action	Note
10	Secure the joint unit with the remaining attachment screws.	Hex socket head cap screw: 3HAB3409-20  <small>xx2300000785</small>
11	Torque tighten all screws crosswise.	M5x55 12.9 Lafre 2C2B/FC6.9, 12 pcs Tightening torque: 8.2 Nm.

Connecting the axis-1 joint unit cabling

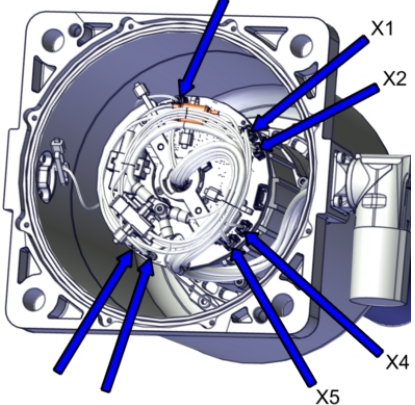
	Action	Note
1	 ELECTROSTATIC DISCHARGE (ESD) The unit is sensitive to ESD. Before handling the unit read the safety information in section The unit is sensitive to ESD on page 53.	
2	Reconnect the connectors to the drive board. <ul style="list-style-type: none"> • D1.X1 to X1 • D1.DC+ to DC+ • D1.DC- to Ground • D1.X4 to X4 • D1.X2 to X2 • D1.X5 to X5 • DR.X8 to X8 	 <small>xx2000002009</small>

Continues on next page

5 Repair

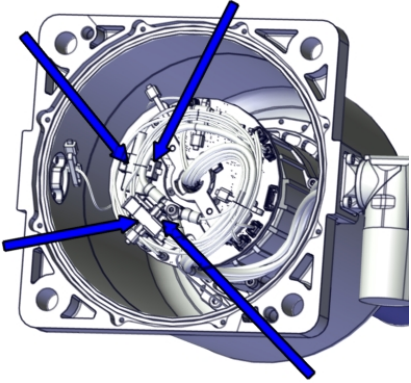
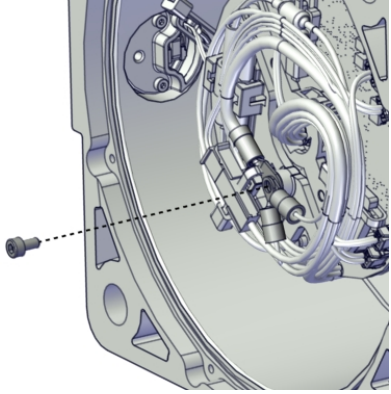
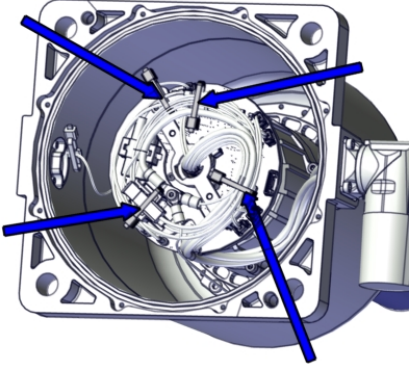

5.5.1 Replacing the base

Continued

	Action	Note
3	<p>Connect the connectors to each other and snap them to the cable holders.</p> <ul style="list-style-type: none">• J1.DC+ to J1.DC+• J1.DC- to J1.DC-• J1.CS to J1.CS• J1.CP to J1.CP	 <p>xx2000002010</p>
4	<p>Secure the cables for functional earth and protective earth with a screw.</p>	<p>Hex socket head cap screw: M3x6 (1 pcs). Tightening torque: 0.8 Nm.</p>  <p>xx2000002011</p>
5	<p>Secure the cabling with cable ties.</p>	<p>Cable ties (4 pcs)</p>  <p>xx2000002012</p>

Continues on next page

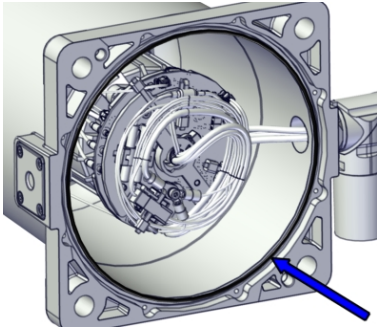
Refitting the base cover (-10/1.52 and -12/1.27)

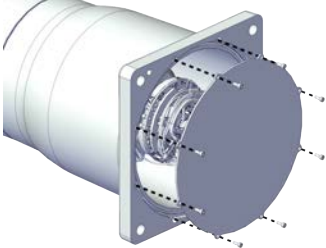
	Action	Note
1	Wipe, lubricate and fit the o-ring to its groove. Replace if damaged.	<p>3HAC061327-072 Grease: 3HAC042536-001 (Shell Gadus S2)</p>  <p>xx2000002016</p>
2	<p>Refit the bottom cover with the attachment screws.</p> <p> Note</p> <p>For CRB 15000-5/0.95, fit the cover in correct direction, the protrusion of the cover must face outwards.</p>	<p>Hex socket head cap screw: M3x8 12.9 Lafre 2C2B/FC6.9 (8 pcs) Tightening torque: 1.4 Nm.</p>  <p>xx2300000760</p>

Securing the base

	Action	Note
1	Lift the base to standing and secure it to the foundation with the attachment screws and washers.	<p>Attachment screws: M10x35 8.8 (4 pcs). Washers: 23/10.5/2.5 mm Steel (4 pcs). Tightening torque: 32 Nm ±10%.</p>  <p>xx2000002006</p>

Continues on next page

5 Repair

5.5.1 Replacing the base

Continued

Refitting the swing(-10/1.52 and -12/1.27)

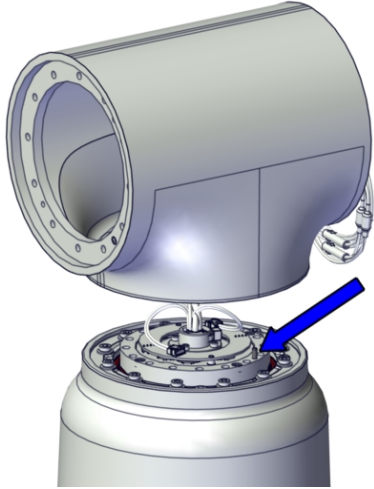
	Action	Note
1	Fit two guide pins on the base unit for position guidance. Always use guide pins in pairs.	Valid for CRB 15000-10/1.52 Guide pin, M5x75, 3HAC087786-002 Valid for CRB 15000-12/1.27 Guide pin, M5x125: 3HAC087786-001
2	Refit the swing to the base unit, aligning the pin with the pin hole.  CAUTION The torque sensor (on the exposed PCBA) is sensitive to mechanical damage. Handle the assembly with care.	Example of CRB 15000-12/1.27, similar to CRB 15000-10/1.52.  xx2000001989

Continues on next page

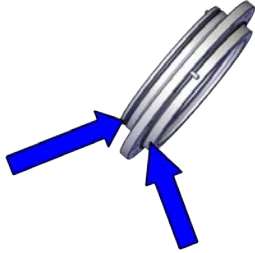

	Action	Note
3	<p>Secure the swing with the attachment screws.</p> <p> CAUTION</p> <p>Do not mix the flange screws used for CRB 15000-5/0.95 and the threaded screws used for CRB 15000-10/1.52 and CRB 15000-12/1.27. Always use washers together with the threaded screws for CRB 15000-10/1.52 and CRB 15000-12/1.27. Illustration is for reference only.</p>	<p>Hex socket head cap screw: M5x30 12.9 Lafre 2C2B/FC6.9 (16 pcs) Tightening torque: 8.2 Nm Valid for CRB 15000-12/1.27</p>  <p>xx2000001987</p> <p>Valid for CRB 15000-10/1.52</p>  <p>xx2300000819</p>
4	<p>Valid for CRB 15000-10/1.52</p> <p>Check the o-rings on both side of the swing flange. Replace if damaged.</p>	<p>O-ring: 3HAC061327-073 O-ring: 3HAC061327-044</p>  <p>xx2300000821</p>
5	<p>Valid for CRB 15000-10/1.52</p> <p>Refit the swing flange with the attachment screws. Always check the serial number printed on the swing parts and use the parts in the same number for refitting.</p> <p> CAUTION</p> <p>Do not use the pre-assembling screws of swing parts for securing.</p>	<p>Hex socket head cap screw: M5x25 12.9 Lafre 2C2B/FC6.9 (16 pcs) Tightening torque: 8.2 Nm</p>  <p>xx2300000818</p>

Continues on next page

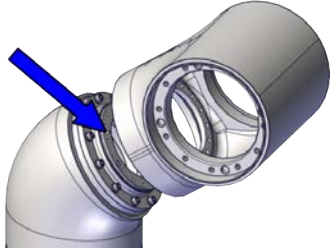

5 Repair

5.5.1 Replacing the base

Continued

	Action	Note
6	<p>Valid for CRB 15000-10/1.52</p> <p>Fit two guide pins on the swing flange for position guidance.</p> <p>Always use guide pins in pairs.</p>	<p>Guide pin, M5x75, 3HAC087786-002</p>
7	<p>Valid for CRB 15000-10/1.52</p> <p>Refit the swing transition to the swing flange, aligning the pin with the pin hole.</p> <p>Always check the serial number printed on the swing parts and use the parts in the same number for refitting.</p>	 <p>xx2300000820</p>
8	<p>Valid for CRB 15000-10/1.52</p> <p>Secure the swing transition with the attachment screws.</p> <p> CAUTION</p> <p>Do not use the pre-assembling screws of swing parts for securing.</p>	<p>Hex socket head cap screw: M5x25 12.9 Lafre 2C2B/FC6.9 (16 pcs)</p> <p>Tightening torque: 8.2 Nm</p>  <p>xx2300000817</p>

Removing the base from foundation (-10/1.52 and -12/1.27)

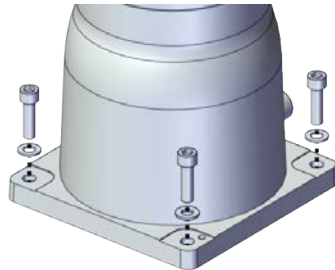
	Action	Note
1	<p> CAUTION</p> <p>The weight of the complete swing and base together is up to 25 kg</p>	
2	<p> WARNING</p> <p>Personnel must not, under any circumstances, be present under the suspended load.</p>	
3	<p>Loosen the robot base from the foundation by removing the foundation attachment screws.</p>	 <p>xx2300001060</p>

Continues on next page

	Action	Note
4	<p>Lay the robot down with the torque sensor side upwards on a working bench. Do not damage the base socket. Caution with the cabling.</p> <p style="text-align: center;"> CAUTION</p> <p>The cabling is sensitive to mechanical damage. Handle it with care to avoid damage to the cabling or the connector, avoid any kind of tilt or skew.</p>	

Refitting the axis-2 joint unit (-10/1.52 and -12/1.27)

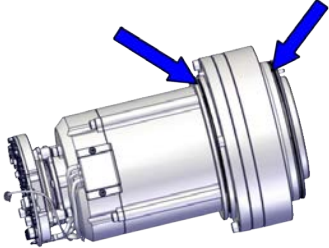
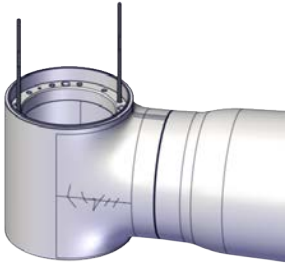

	Action	Note
1	<p style="text-align: center;"> ELECTROSTATIC DISCHARGE (ESD)</p> <p>The unit is sensitive to ESD. Before handling the unit read the safety information in section The unit is sensitive to ESD on page 53.</p>	
2	<p>Check the o-rings. Replace if damaged.</p>	<p>O-ring: 3HAC061327-044</p>  <p style="text-align: right; font-size: small;">xx2300000823</p>
3	<p>Fit two guide pins to the swing.</p>	<p>Guide pin, M5x125: 3HAC087786-001</p> <p>Always use guide pins in pairs.</p> <p>For joint units on axes 1 and 2 of CRB 15000-10/1.52 and CRB 15000-12/1.27.</p>  <p style="text-align: right; font-size: small;">xx2300000791</p>

Continues on next page

5 Repair

5.5.1 Replacing the base

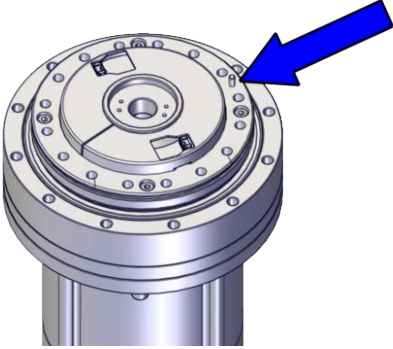
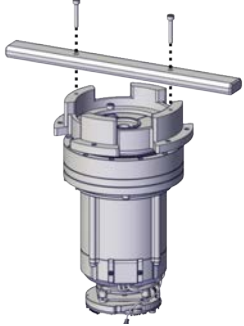
Continued

	Action	Note
4	<p>Fit the lifting aid to the joint unit, aligning the pin with the pin hole.</p> <p> CAUTION</p> <p>The connectors and the joint unit cables are sensitive to mechanical damage. Handle the assembly with care.</p>  <p>xx2300000777</p>	<p>Joint unit: 3HAC087472-001 Lifting aid: 3HAC087787-001 Screws: M5x30 (4 pcs for plate and 2 pcs for beam)</p>  <p>xx2300000778</p>  <p>xx2300000776</p>
5	<p>Place the axis-1 cabling properly to avoid squeezing by the joint unit when putting the joint unit into the swing.</p> <p> CAUTION</p> <p>The cabling is sensitive to mechanical damage. Handle it with care to avoid damage to the cabling or the connector, avoid any kind of tilt or skew.</p>	

Continues on next page

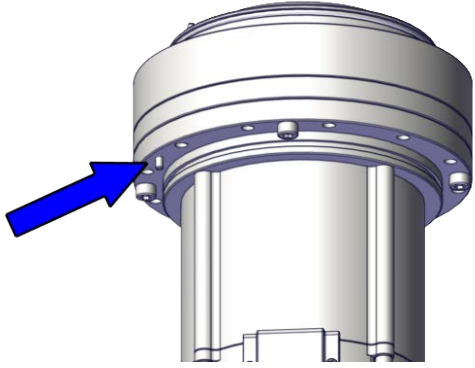
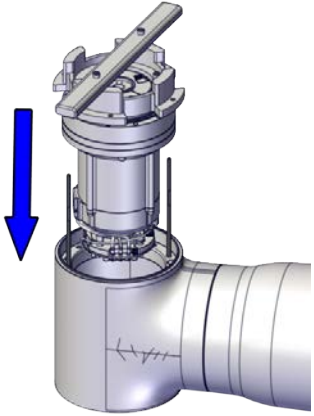
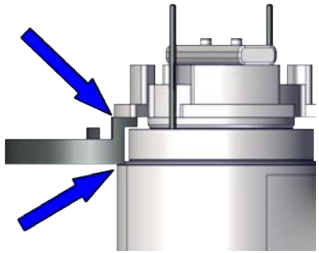
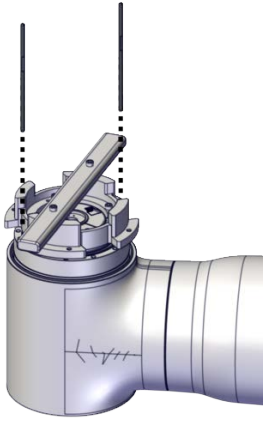
	Action	Note
6	<p>Fit the joint unit to the swing, aligning the pin with the pin hole.</p> <p> CAUTION</p> <p>The connectors and the joint unit cables are sensitive to mechanical damage. Handle the assembly with care.</p>  <p>xx2300000780</p>	 <p>xx2300000792</p>
7	<p>Check the joint unit position by placing the higher boss of one semicircular block between the lifting aid and swing.</p> <p>The joint unit is properly placed when no gaps between the block and both lifting aid and swing.</p>	 <p>xx2300000794</p>
8	<p>Remove the guide pins.</p>	 <p>xx2300000795</p>

Continues on next page

5 Repair

5.5.1 Replacing the base

Continued

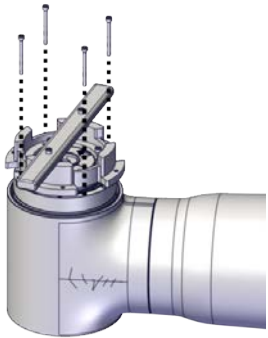
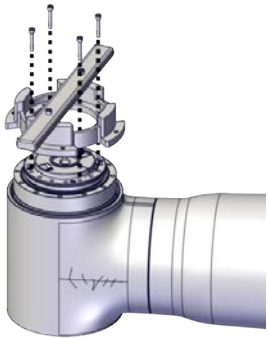
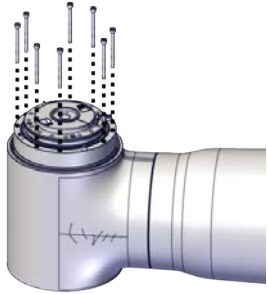

	Action	Note
9	Secure with four attachment screws and pre-tighten the screws crosswise.	 <p>xx2300000796</p>
10	Remove the lifting aid by removing the screws.	 <p>xx2300000797</p>
11	Secure the joint unit with the remaining attachment screws.	<p>Hex socket head cap screw: 3HAB3409-20</p>  <p>xx2300000798</p>
12	Torque tighten all screws crosswise.	<p>M5x55 12.9 Lafre 2C2B/FC6.9, 12 pcs Tightening torque: 8.2 Nm.</p>

Continues on next page

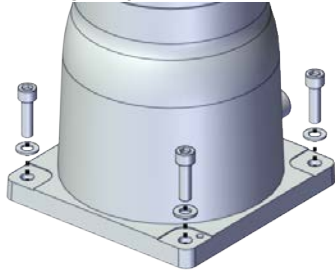
Securing the base (-10/1.52 and -12/1.27)

	Action	Note
1	Lift the base to standing and secure it to the foundation with the attachment screws and washers.	<p>Attachment screws: M10x35 8.8 (4 pcs). Washers: 23/10.5/2.5 mm Steel (4 pcs). Tightening torque: 32 Nm ±10%.</p>  <p>xx2300001060</p>

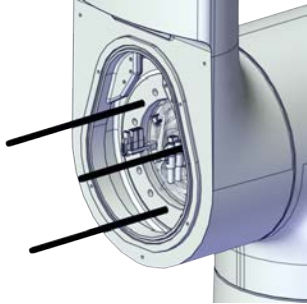
Refitting the lower and upper arm assembled (-10/1.52 and -12/1.27)





	Action	Note
1	Fit three guide pins to the axis-2 joint unit.	<p>Guide pin, M5x125: 3HAC087786-001</p>  <p>xx2300001021</p>
2	<p> CAUTION</p> <p>The weight of the complete upper and lower arm together is up to 26 kg</p>	

Continues on next page

5 Repair

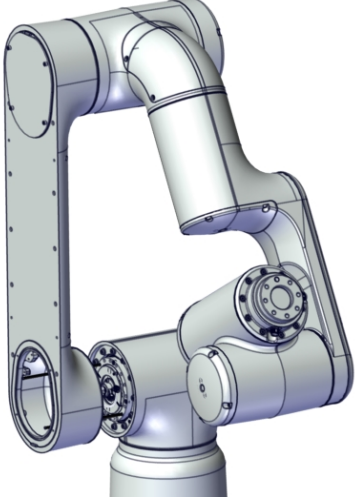
5.5.1 Replacing the base

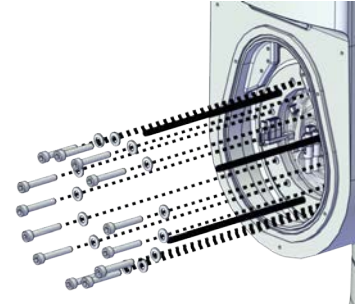
Continued

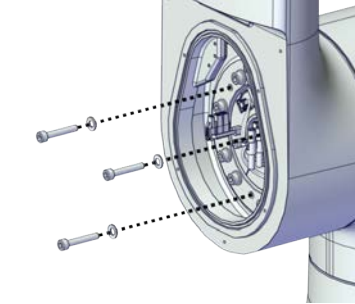
	Action	Note
3	Lift the upper and lower arm assembly to mounting position and slide it onto the guide pins.	<p>Example of CRB 15000-5/0.95, similar to CRB 15000-10/1.52 and CRB 15000-12/1.27.</p>  <p>xx2000001941</p>
4	<p>Secure the lower arm to the swing with all screws and washers but two. Pre-tighten the screws crosswise firstly.</p> <p> CAUTION</p> <p>Do not mix the flange screws used for CRB 15000-5/0.95 and the threaded screws used for CRB 15000-10/1.52 and CRB 15000-12/1.27. Always use washers together with the threaded screws for CRB 15000-10/1.52 and CRB 15000-12/1.27. Illustration is for reference only.</p>	<p>Hex socket head cap screw: M5x30 12.9 Lafre 2C2B/FC6.9, 16 pcs</p>  <p>xx2300001022</p>
5	<p>Remove the guide pins and fasten the remaining two screws and washers.</p> <p> CAUTION</p> <p>Do not mix the flange screws used for CRB 15000-5/0.95 and the threaded screws used for CRB 15000-10/1.52 and CRB 15000-12/1.27. Always use washers together with the threaded screws for CRB 15000-10/1.52 and CRB 15000-12/1.27. Illustration is for reference only.</p>	<p>Hex socket head cap screw: M5x30 12.9 Lafre 2C2B/FC6.9, 16 pcs</p>  <p>xx2300001023</p>
6	Torque tighten all screws crosswise.	Tightening torque: 8.2 Nm

Continues on next page

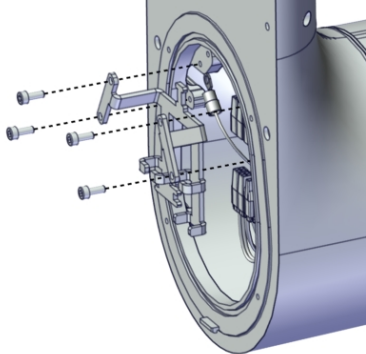
	Action	Note
7	Refit the cable bracket with four screws.	<p>Hex socket head cap screw: M3x8 12.9 Lafre 2C2B/FC6.9 (4 pcs). Tightening torque: 0.8 Nm</p>  <p>xx2000001939</p>

Connecting the axis-2 joint unit cabling

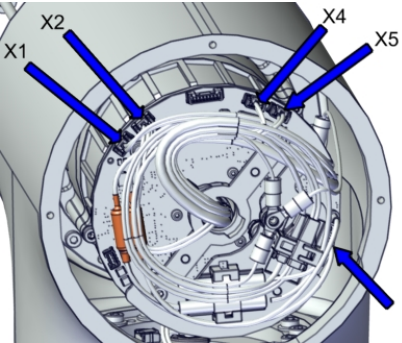
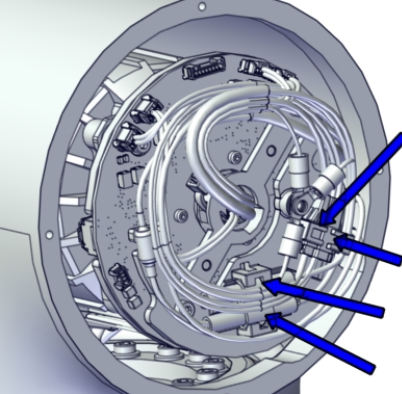
	Action	Note
1	 <p>ELECTROSTATIC DISCHARGE (ESD)</p> <p>The unit is sensitive to ESD. Before handling the unit read the safety information in section The unit is sensitive to ESD on page 53.</p>	
2	<p>Reconnect the connectors to the drive board.</p> <ul style="list-style-type: none"> • D2.X1 to X1 • D2.DC+ to DC+ • D2.DC- to Ground • D2.X4 to X4 • D2.X2 to X2 • D2.X5 to X5 	 <p>xx2000002013</p>
3	<p>Connect the connectors to each other and snap them to the cable holders.</p> <ul style="list-style-type: none"> • J2.DC+ to J2.DC+ • J2.DC- to J2.DC- • J2.CS to J2.CS • J2.CP to J2.CP 	 <p>xx2000001944</p>

Continues on next page

5 Repair

5.5.1 Replacing the base

Continued

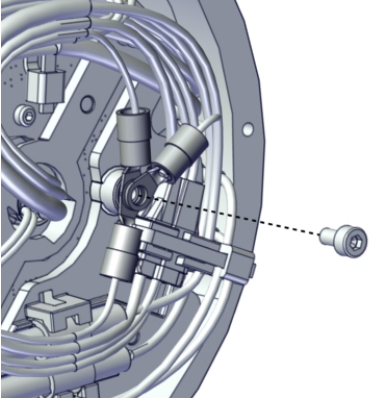
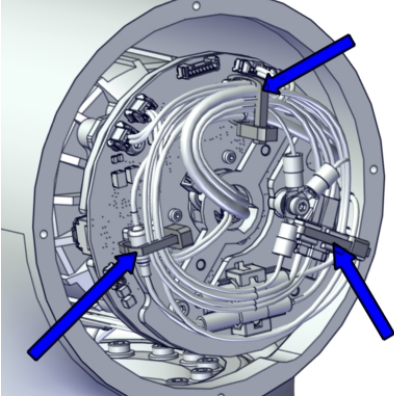
	Action	Note
4	Secure the cables for functional earth and protective earth with a screw.	<p>Hex socket head cap screw: M3x6 (1 pcs).</p> <p>Tightening torque: 0.8 Nm.</p>  <p>xx2000001945</p>
5	Secure the cabling with cable ties.	<p>Cable ties (3 pcs)</p>  <p>xx2000001946</p>

Connecting the cabling between the lower arm and swing

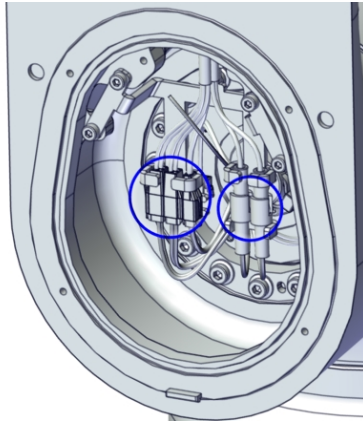
	Action	Note
1	Connect the connectors to each other and snap them to the cable holders.	 <p>xx2000001938</p>

Continues on next page

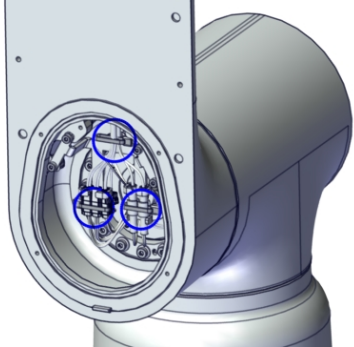
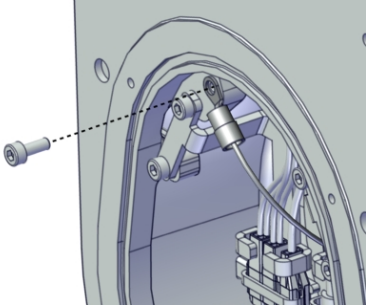
	Action	Note
2	Secure the cabling with cable ties.	<p>Cable ties (3 pcs)</p>  <p>xx2000001937</p>
3	Connect the functional earth cable with the screw.	<p>Hex socket head cap screw: M3x8 12.9 Lafre 2C2B/FC6.9 (1 pcs). Tightening torque: 0.8 Nm</p>  <p>xx2000001936</p>

Removing the lower arm covers (-10/1.52 and -12/1.27)

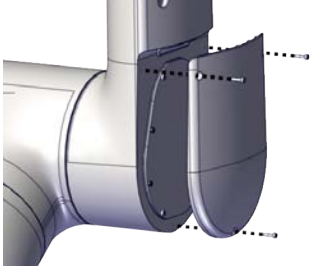
	Action	Note
1	 CAUTION Make sure that all supplies for electrical power are turned off.	
2	Remove the lower cover of lower arm by removing the screws.	 <p>xx2300000812</p>

Continues on next page

5 Repair

5.5.1 Replacing the base

Continued

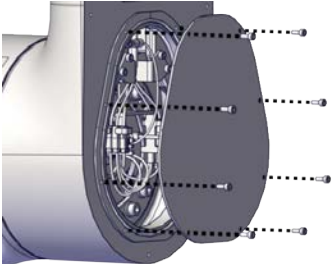
	Action	Note
3	Remove the lower inner cover by removing the screws.	 <p data-bbox="1029 582 1141 604">xx230000813</p>

Refitting the swing cover and insert(-10/1.52 and -12/1.27)

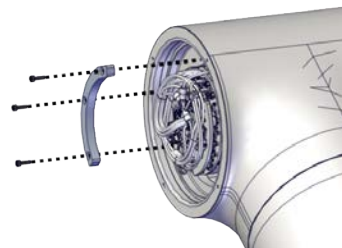
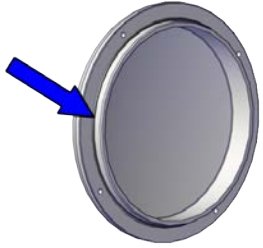
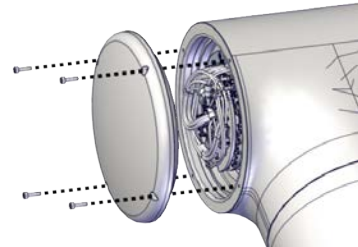
	Action	Note
1	Refit the insert.	<p data-bbox="1029 750 1404 884"> Insert: 3HAC084002-001 Hex socket head cap screw: M3x10 12.9 Lafre 2C2B/FC6.9 (3 pcs) Tightening torque: 1.4 Nm </p>  <p data-bbox="1029 1153 1141 1176">xx230000815</p>
2	Fit the o-ring to cover groove. Replace if damaged.	<p data-bbox="1029 1209 1404 1288"> O-ring: 3HAC061327-074 (for CRB 15000-10/1.52 and CRB 15000-12/1.27) </p>  <p data-bbox="1029 1568 1141 1590">xx230000816</p>
3	Refit the cover with the four screws.	<p data-bbox="1029 1624 1404 1713"> Hex socket head cap screw: M3x12 12.9 Lafre 2C2B/FC6.9 (4 pcs) Tightening torque: 1.4 Nm </p>  <p data-bbox="1029 1993 1141 2016">xx230000814</p>

Continues on next page

Concluding procedure

	Action	Note
1	Calibrate the joint unit torque sensor for the axis-1 and axis-2 joint units.	See Calibration on page 1063
2	 DANGER Make sure all safety requirements are met when performing the first test run. See Test run after installation, maintenance, or repair on page 90 .	

5 Repair

5.5.2 Replacing the swing

5.5.2 Replacing the swing

Location of the swing

The swing is located as shown in the figure.

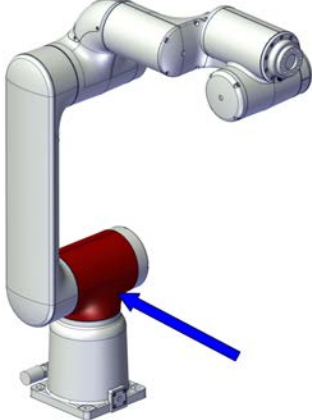
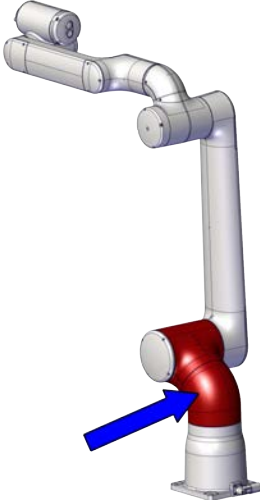
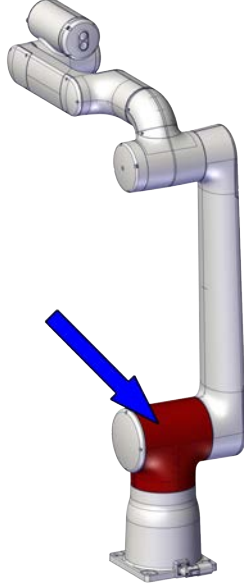
CRB 15000-5/0.95	CRB 15000-10/1.52	CRB 15000-12/1.27
 xx2000001986	 xx2300000766	 xx2300000769

Summary of the replacement procedure

This is a brief summary of the replacement procedure, containing the major actions to be performed.

- 1 Separate the cabling between the swing and the lower arm.
- 2 Remove the lower and upper arm undivided.
- 3 Remove the swing cover.
- 4 (For CRB 15000-10/1.52 and CRB 15000-12/1.27) Loosen the base from the foundation and lay it down with the torque sensor side upwards.
- 5 Remove the axis-2 joint unit.
- 6 Replace the swing.

Required spare parts



Note

The spare part numbers that are listed in the table can be out of date. See the latest spare parts of the CRB 15000 via myABB Business Portal, www.abb.com/myABB.

Continues on next page

Spare part	Article number	Note
Swing	3HAC073933-001	Used for CRB 15000-5/0.95. Also order new attachment screws for the axis-2 joint unit: 3HAB3413-435 (12 pcs).
Swing (CRB 15000-10/1.52)	3HAC087548-001	Used for CRB 15000-10/1.52. Also include O-ring (3HAC061327-073) and O-ring (3HAC061327-044).
Swing (CRB 15000-12/1.27)	3HAC087547-001	Used for CRB 15000-12/1.27.
Flange socket head screw with glue	3HAB3413-435	M4x35 12.9 Lafre 2C2B/FC6.9+PrO-COat111, with NYPLAS glue , 12 pcs Used for joint unit of CRB 15000-5/0.95. Always use new screws when re-fitting a joint unit. If ordering a new joint unit spare part, new screws are included.
Cable tie	3HAC075545-001	For securing joint unit cable.

Required tools and equipment

Equipment	Article number	Note
Lifting aid	3HAC077788-001	For joint units on axes 1, 2 and 3 of CRB 15000-5/0.95. Attachment screws M4x35 (4 pcs) are enclosed.
Lifting aid	3HAC087787-001	For joint units on axes 1 and 2 of CRB 15000-10/1.52 and CRB 15000-12/1.27. A plate, a beam, a pair of semicircular blocks and attachment screws M5x30 (2 pcs) are enclosed.
Guide pin, M4x120	3HAC077786-001	Always use guide pins in pairs. For joint units on axes 1, 2 and 3 of CRB 15000-5/0.95 and axis 3 of CRB 15000-10/1.52 and CRB 15000-12/1.27.
Guide pin, M5x125	3HAC087786-001	Always use guide pins in pairs. For joint units on axes 1 and 2 of CRB 15000-10/1.52 and CRB 15000-12/1.27.
Guide pin, M5x75	3HAC087786-002	Always use guide pins in pairs.
Standard toolkit	-	Content is defined in section Standard toolkit on page 1099 .

Required consumables

Consumable	Article number	Note
Cleaning agent	-	Isopropanol

Continues on next page

5 Repair

5.5.2 Replacing the swing

Continued



Consumable	Article number	Note
Flange sealant	-	Loctite 574
Grease	3HAC042536-001	Shell Gadus S2
Cable ties	-	
O-ring	3HAC061327-044	Axis-1 and -2 joint unit, used for CRB 15000-10/1.52 and CRB 15000-12/1.27. Replace if damaged.
O-ring	3HAC061327-047	Cover for axis 2/3, used for CRB 15000-5/0.95. Replace if damaged.
O-ring	3HAC061327-074	Swing cover, used for CRB 15000-10/1.52 and CRB 15000-12/1.27. Replace if damaged.
O-ring	3HAC061327-073	Swing flange, big side, used for CRB 15000-10/1.52. Replace if damaged.
O-ring	3HAC061327-044	Swing flange, small side, used for CRB 15000-10/1.52. Replace if damaged.
O-ring	3HAC061327-044	Lower arm, inner cover of CRB 15000-5/0.95. 1 pcs / cover. Replace if damaged.
O-ring	3HAC061327-075	Lower arm, lower inner cover of CRB 15000-10/1.52 and CRB 15000-12/1.27. Replace if damaged.

Continues on next page

Removing the swing (-5/0.95)

Use these procedures to remove the swing.

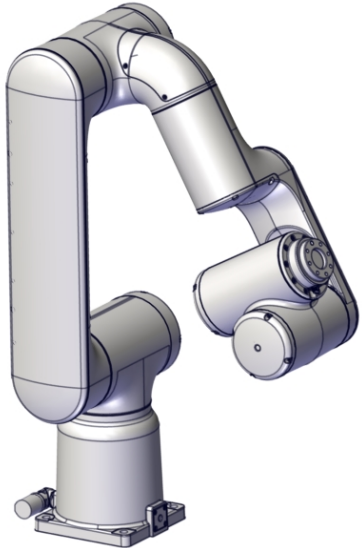
Preparations before removing the swing

	Action	Note
1	<p>Jog the robot to the specified position:</p> <ul style="list-style-type: none"> • Axis 1: 0° • Axis 2: 0° (home position) • Axis 3: +60° • Axis 4: 0° • Axis 5: -90° • Axis 6: No significance. <p> CAUTION</p> <p>Jog the axis on which the joint unit is to be replaced to home position, to achieve correct cable routing during replacement of the joint unit.</p>	 <p>xx2100000044</p>
2	<p> DANGER</p> <p>Turn off all:</p> <ul style="list-style-type: none"> • electric power supply • hydraulic pressure supply • air pressure supply <p>to the robot, before entering the safeguarded space.</p>	

Removing the lower arm covers (-5/0.95)

	Action	Note
1	<p> CAUTION</p> <p>Make sure that all supplies for electrical power are turned off.</p>	

Continues on next page

5 Repair

5.5.2 Replacing the swing

Continued

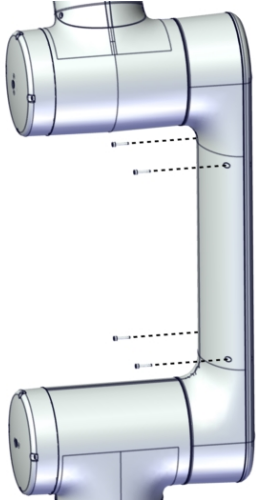
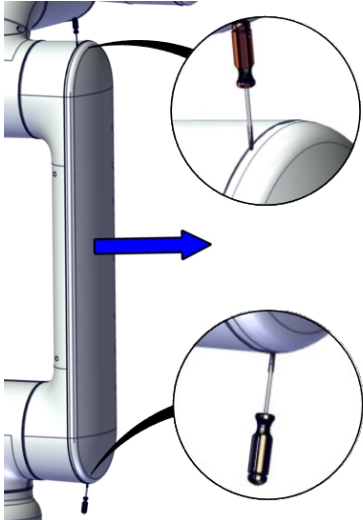
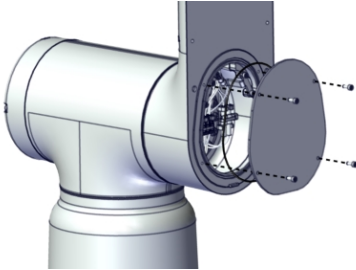
	Action	Note
2	Remove the four lower arm cover screws.	 <p>xx2000001929</p>
3	Remove the cover by inserting a small flat screwdriver to snap open the locks at each end of the cover.	 <p>xx2100000267</p>
4	Remove the inner cover by removing the four screws.	 <p>xx2000001930</p>

Continues on next page

Disconnecting the cabling between the lower arm and the swing

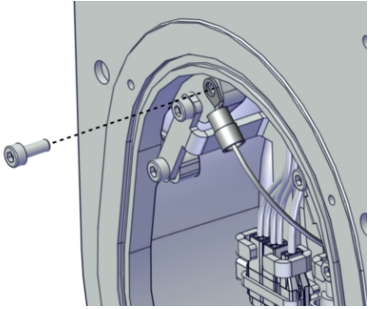
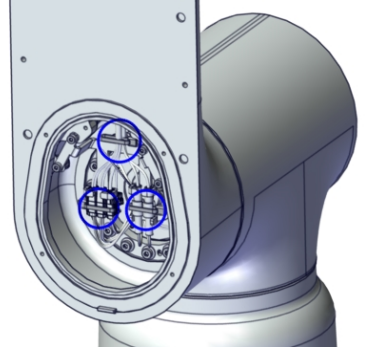
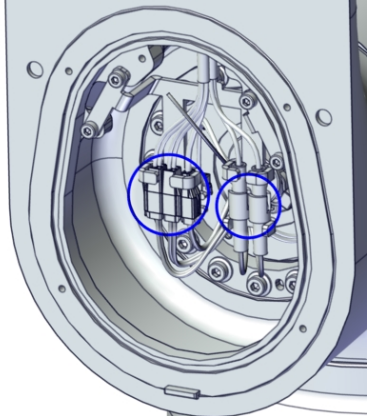
	Action	Note
1	Remove the functional earth cable by removing the screw.	 <p>xx2000001936</p>
2	Cut the cable ties.	 <p>xx2000001937</p>
3	Snap loose and disconnect all connectors.	 <p>xx2000001938</p>



Continues on next page

5 Repair

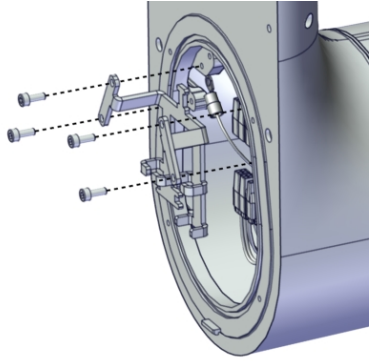

5.5.2 Replacing the swing

Continued

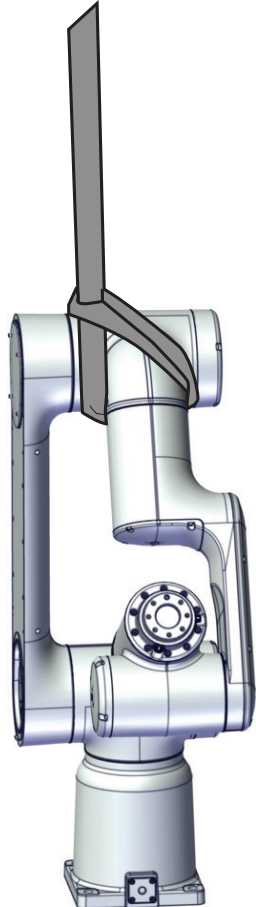
Removing the lower and upper arm assembled

	Action	Note
1	Remove the cable bracket by removing the four screws.	 <p data-bbox="1027 734 1137 757">xx2000001939</p>
2	<p data-bbox="480 790 1018 824">Secure the weight of the upper and lower arm.</p> <p data-bbox="480 837 687 891"> CAUTION</p> <p data-bbox="480 909 1018 965">The weight of the complete upper and lower arm together is 18 kg</p>	<p data-bbox="1027 790 1412 846">Suggestion with lifting sling and an overhead crane.</p> <p data-bbox="1027 853 1412 931">Example of CRB 15000-5/0.95, similar to CRB 15000-10/1.52 and CRB 15000-12/1.27.</p>  <p data-bbox="1027 1865 1137 1888">xx2100000294</p>

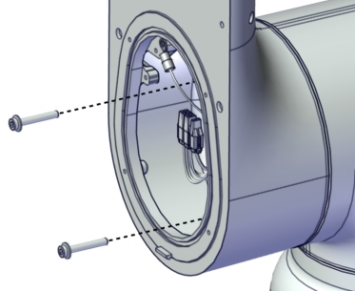
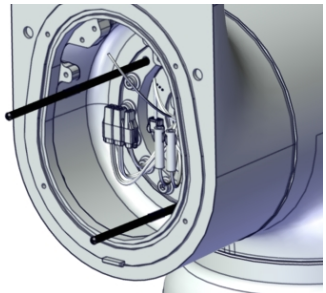
Continues on next page

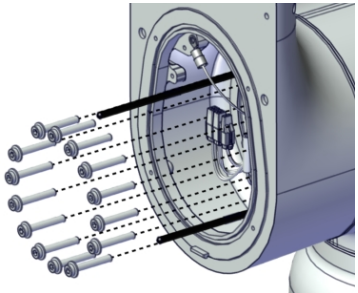
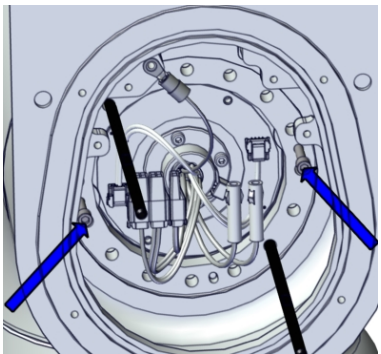
	Action	Note
3	<p>Remove two attachment screws and fit two guide pins to the axis-2 joint unit.</p> <p> CAUTION</p> <p>Do not mix the flange screws used for CRB 15000-5/0.95 and the threaded screws used for CRB 15000-10/1.52 and CRB 15000-12/1.27. Always use washers together with the threaded screws for CRB 15000-10/1.52 and CRB 15000-12/1.27. Illustration is for reference only.</p>	<p>Guide pin, M4x120: 3HAC077786-001</p> <p>Always use guide pins in pairs.</p>  <p>xx2000001951</p>  <p>xx2000001960</p>
4	<p>Remove the lower arm attachment screws.</p> <p> CAUTION</p> <p>Do not mix the flange screws used for CRB 15000-5/0.95 and the threaded screws used for CRB 15000-10/1.52 and CRB 15000-12/1.27. Always use washers together with the threaded screws for CRB 15000-10/1.52 and CRB 15000-12/1.27. Illustration is for reference only.</p>	 <p>xx2000001940</p>
5	<p>Use two fully threaded attachment screws as removal tools to press the lower arm out of position.</p>	 <p>xx2000002151</p>

Continues on next page

5 Repair

5.5.2 Replacing the swing

Continued

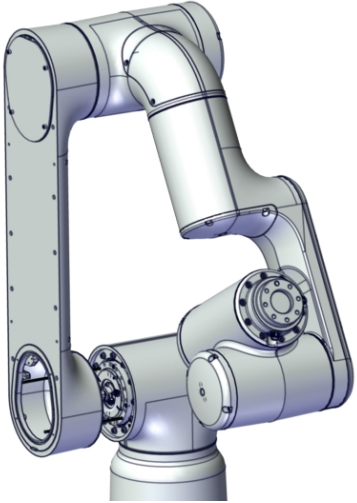
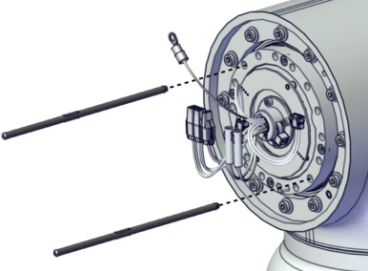
	Action	Note
6	Remove the complete arm system from the swing.	 <p>xx2000001941</p>
7	Remove the guide pins.	 <p>xx2000002432</p>

Removing the swing cover (-5/0.95)

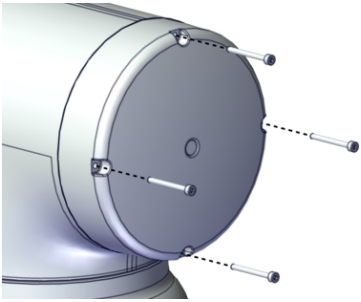
	Action	Note
1	 CAUTION Make sure that all supplies for electrical power are turned off.	
2	Remove the cover screws.	 <p>xx2000001935</p>

Continues on next page

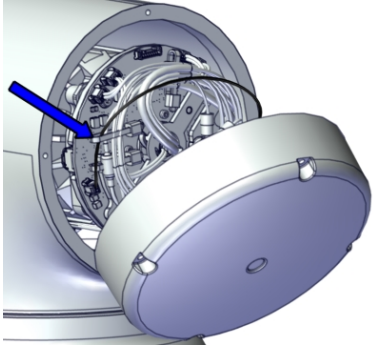
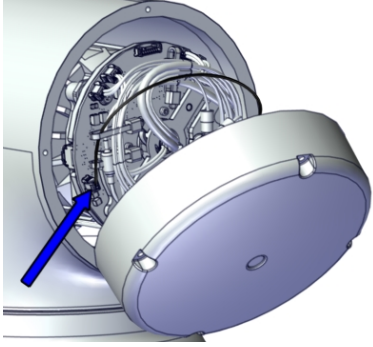
	Action	Note
3	<p> CAUTION</p> <p>Valid for CRB 15000-5/0.95</p> <p>There is cabling connected between the cover and the joint unit drive board.</p> <p>Open the cover with care to avoid damage to the cabling or the connector(s).</p> <p>Do not leave the cover in location without being secured with the attachment screws.</p>	
4	<p>For robots with RobotWare earlier than 7.10</p> <p>Open the cover and cut the cable tie that holds the brake release cable.</p>	 <p>xx2000001931</p>
5	<p>For robots with RobotWare earlier than 7.10</p> <p>Disconnect the brake release connector DR.X8 from the drive board.</p> <p>Remove the cover.</p>	 <p>xx2000001932</p>

Disconnecting the axis-2 joint unit cabling



	Action	Note
1	<p> ELECTROSTATIC DISCHARGE (ESD)</p> <p>The unit is sensitive to ESD. Before handling the unit read the safety information in section The unit is sensitive to ESD on page 53.</p>	

Continues on next page

5 Repair

5.5.2 Replacing the swing

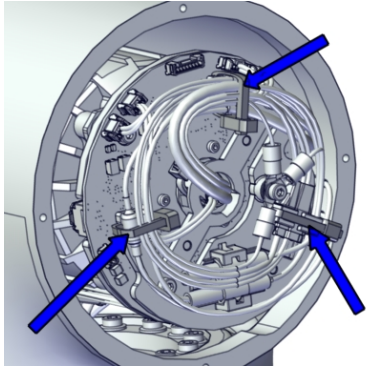
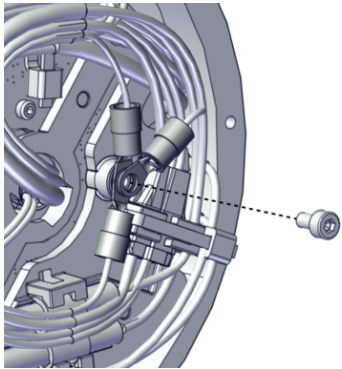
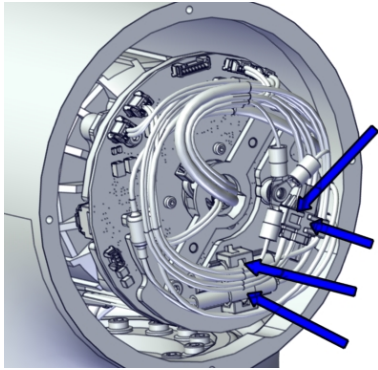
Continued

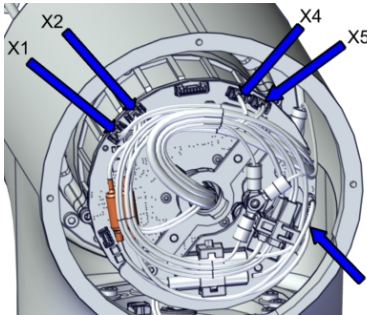
	Action	Note
2	Cut the cable ties.	 xx2000001946
3	Remove the functional and protective earth cables by removing the screw.	 xx2000001945
4	Snap loose and disconnect the connectors: <ul style="list-style-type: none">• J2.DC+• J2.DC-• J2.CS• J2.CP	 xx2000001944
5	Disconnect the connectors from the drive board. <ul style="list-style-type: none">• D2.X1 from X1• D2.DC+ from DC+• D2.DC- from ground• D2.X4 from X4• D2.X2 from X2• D2.X5 from X5 <p> CAUTION</p> Use tweezers to unlock connectors and pull them off.	 xx2000002013

Continues on next page

Removing the axis-2 joint unit (-5/0.95)

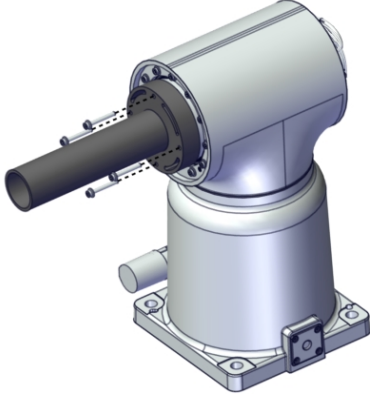
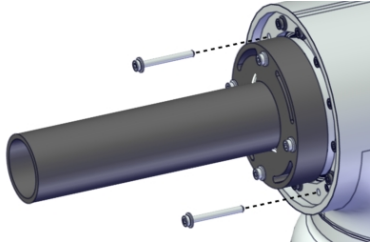
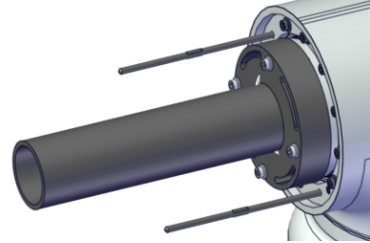
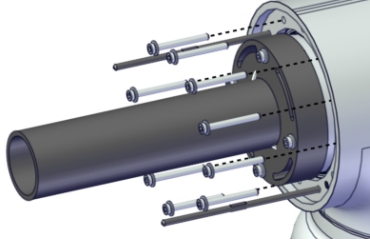

	Action	Note
1	<p>Fit the lifting aid to the joint unit, on the torque sensor side.</p> <p> CAUTION</p> <p>The connectors and the joint unit cables are sensitive to mechanical damage. Handle the assembly with care.</p>	<p>Lifting aid: 3HAC077788-001 Screws: M4x35 (4 pcs)</p>  <p>xx2000001956</p>
2	<p>Remove two attachment screws. Dispose the screws. New screws are included in the spare part delivery of the joint unit.</p>	 <p>xx2100000295</p>
3	<p>Fit two guide pins to the axis-2 joint unit.</p>	<p>Guide pin, M4x120: 3HAC077786-001 Always use guide pins in pairs. For joint units on axes 1, 2 and 3 of CRB 15000-5/0.95 and axis 3 of CRB 15000-10/1.52 and CRB 15000-12/1.27.</p>  <p>xx2000002433</p>
4	<p>Remove the remaining attachment screws. Use two screws as press out screws in the upcoming step, then dispose all screws. New screws are included in the spare part delivery of the joint unit.</p>	 <p>xx2000001943</p>

Continues on next page

5 Repair



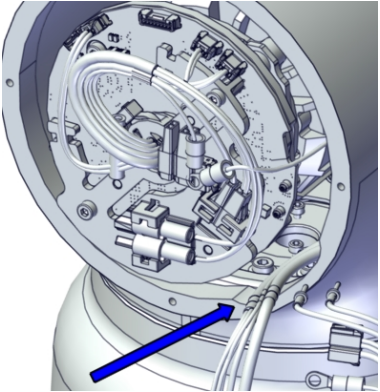
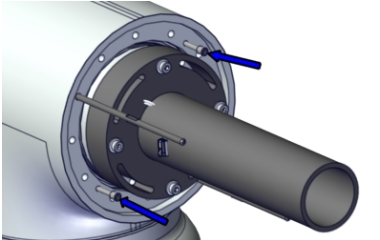

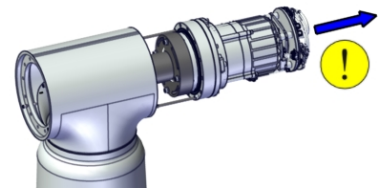
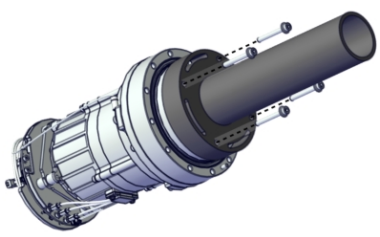
5.5.2 Replacing the swing

Continued

	Action	Note
5	Put the cabling at the slot in order not to squeeze it during removal of joint unit.	 xx2100000045
6	Press the joint unit out of position using two of the previous attachment screws as removal tools.	 xx2000002434
7	<p>Remove the joint unit from the swing.</p> <p> CAUTION</p> <p>The connectors and the joint unit cables are sensitive to mechanical damage. Handle the assembly with care.</p>	 xx2000001958
8	Remove the lifting aid and guide pins.	 xx2000001957

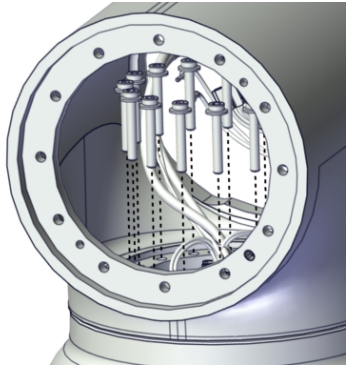
Continues on next page

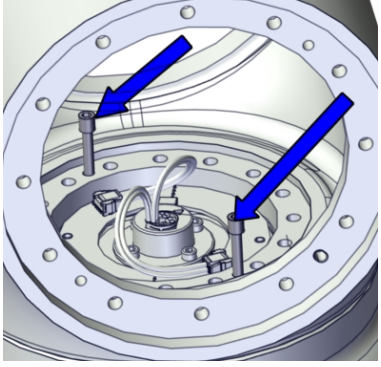
Removing the swing (-5/0.95)

	Action	Note
1	<p>Remove the swing attachment screws.</p> <p> CAUTION</p> <p>Do not mix the flange screws used for CRB 15000-5/0.95 and the threaded screws used for CRB 15000-10/1.52 and CRB 15000-12/1.27. Always use washers together with the threaded screws for CRB 15000-10/1.52 and CRB 15000-12/1.27. Illustration is for reference only.</p>	 <p>xx2000001987</p>
2	<p>Use two fully threaded attachment screws as removal tools to press the swing out of position.</p> <p> CAUTION</p> <p>Do not mix the flange screws used for CRB 15000-5/0.95 and the threaded screws used for CRB 15000-10/1.52 and CRB 15000-12/1.27. Always use washers together with the threaded screws for CRB 15000-10/1.52 and CRB 15000-12/1.27. Illustration is for reference only.</p>	 <p>xx2000002152</p>
3	<p>Lift away the swing.</p> <p> CAUTION</p> <p>The torque sensor (on the exposed PCBA) is sensitive to mechanical damage. Handle the assembly with care.</p>	

Continues on next page

5 Repair



5.5.2 Replacing the swing

Continued

Removing the swing (-10/1.52 and -12/1.27)

Use these procedures to remove the swing.

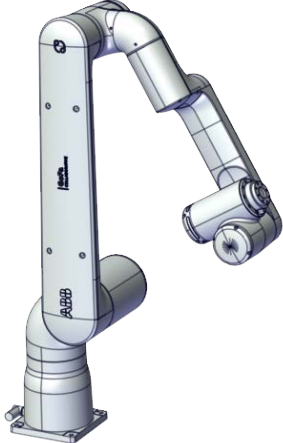
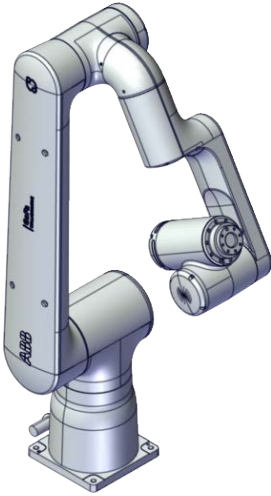
Preparations before removing the swing

	Action	Note
1	<p>Jog the robot to the specified position:</p> <ul style="list-style-type: none"> • Axis 1: 0° • Axis 2: 0° (home position) • Axis 3: +60° • Axis 4: 0° • Axis 5: -90° • Axis 6: No significance. <p> CAUTION</p> <p>Jog the axis on which the joint unit is to be replaced to home position, to achieve correct cable routing during replacement of the joint unit.</p>	<p>Valid for CRB 15000-10/1.52</p>  <p>xx2300001062</p> <p>Valid for CRB 15000-12/1.27</p>  <p>xx2300001063</p>
2	<p> DANGER</p> <p>Turn off all:</p> <ul style="list-style-type: none"> • electric power supply • hydraulic pressure supply • air pressure supply <p>to the robot, before entering the safeguarded space.</p>	

Continues on next page

Removing the lower arm covers (-10/1.52 and -12/1.27)

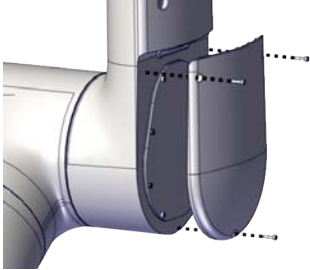
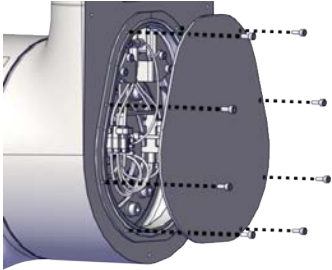
	Action	Note
1	 CAUTION Make sure that all supplies for electrical power are turned off.	
2	Remove the lower cover of lower arm by removing the screws.	 <p>xx2300000812</p>
3	Remove the lower inner cover by removing the screws.	 <p>xx2300000813</p>

Disconnecting the cabling between the lower arm and the swing

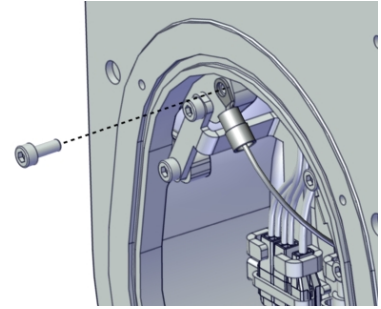
	Action	Note
1	Remove the functional earth cable by removing the screw.	 <p>xx2000001936</p>

Continues on next page

5 Repair

5.5.2 Replacing the swing

Continued

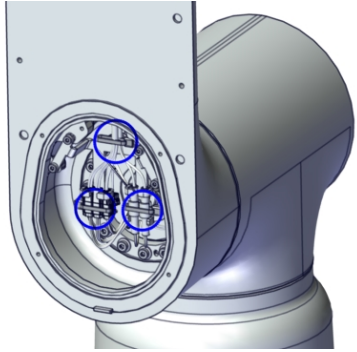
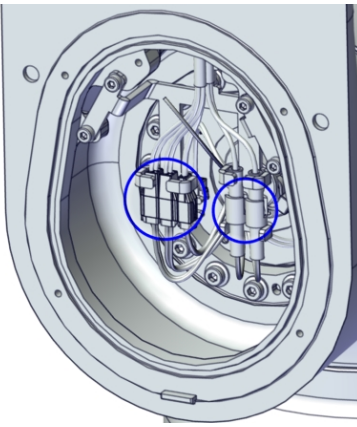
	Action	Note
2	Cut the cable ties.	 <p>xx2000001937</p>
3	Snap loose and disconnect all connectors.	 <p>xx2000001938</p>

Removing the lower and upper arm assembled

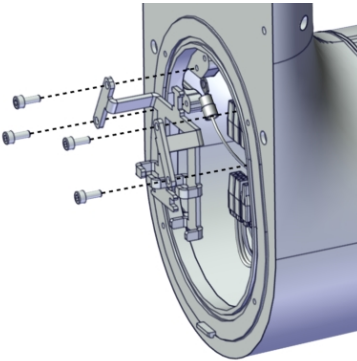
	Action	Note
1	Remove the cable bracket by removing the four screws.	 <p>xx2000001939</p>

Continues on next page

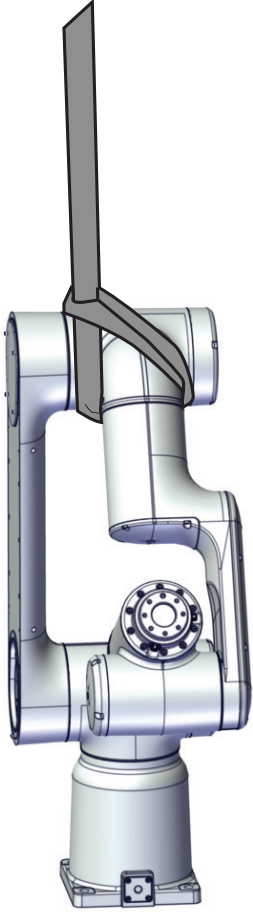

	Action	Note
2	<p>Secure the weight of the upper and lower arm.</p> <p> CAUTION</p> <p>The weight of the complete upper and lower arm together is up to 26 kg</p>	<p>Suggestion with lifting sling and an overhead crane.</p> <p>Example of CRB 15000-5/0.95, similar to CRB 15000-10/1.52 and CRB 15000-12/1.27.</p>  <p>xx210000294</p>

Continues on next page

5 Repair

5.5.2 Replacing the swing

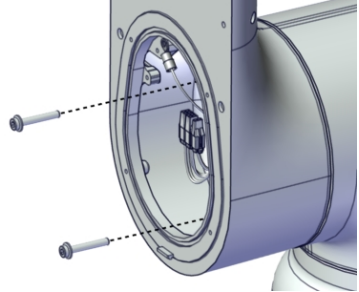
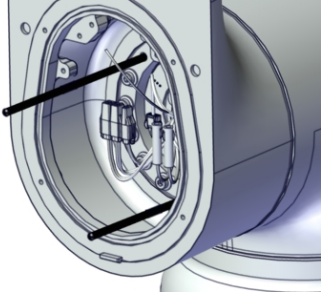
Continued

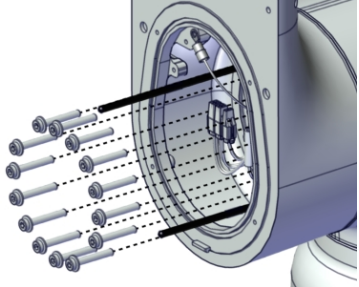
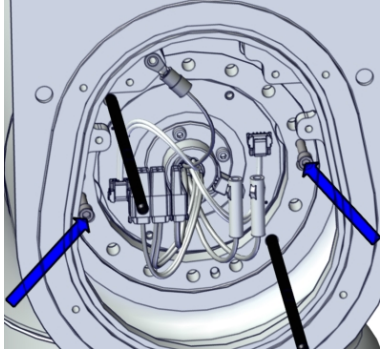
	Action	Note
3	<p>Remove two attachment screws and fit two guide pins to the axis-2 joint unit.</p> <p> CAUTION</p> <p>Do not mix the flange screws used for CRB 15000-5/0.95 and the threaded screws used for CRB 15000-10/1.52 and CRB 15000-12/1.27. Always use washers together with the threaded screws for CRB 15000-10/1.52 and CRB 15000-12/1.27. Illustration is for reference only.</p>	<p>Guide pin, M5x125: 3HAC087786-001</p> <p>Always use guide pins in pairs.</p>  <p>xx2000001951</p>  <p>xx2000001960</p>
4	<p>Remove the lower arm attachment screws.</p> <p> CAUTION</p> <p>Do not mix the flange screws used for CRB 15000-5/0.95 and the threaded screws used for CRB 15000-10/1.52 and CRB 15000-12/1.27. Always use washers together with the threaded screws for CRB 15000-10/1.52 and CRB 15000-12/1.27. Illustration is for reference only.</p>	 <p>xx2000001940</p>
5	<p>Use two fully threaded attachment screws as removal tools to press the lower arm out of position.</p>	 <p>xx2000002151</p>

Continues on next page

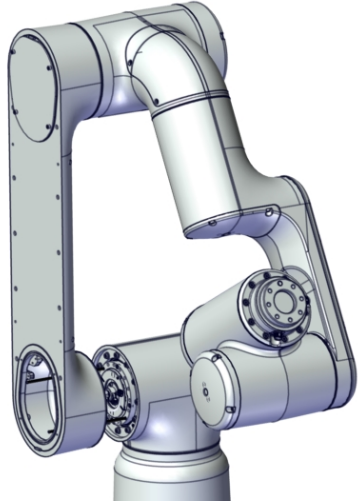
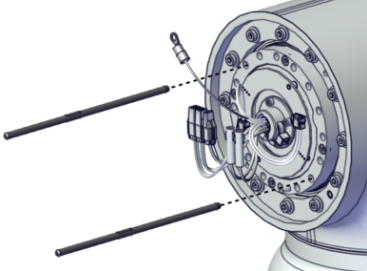
	Action	Note
6	Remove the complete arm system from the swing.	 <p>xx2000001941</p>
7	Remove the guide pins.	 <p>xx2000002432</p>

Removing the swing cover and insert (-10/1.52 and -12/1.27)

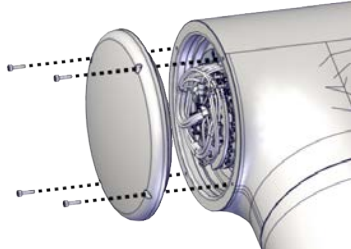
	Action	Note
1	 CAUTION Make sure that all supplies for electrical power are turned off.	
2	Remove the cover by removing the screws.	 <p>xx2300000814</p>

Continues on next page

5 Repair

5.5.2 Replacing the swing

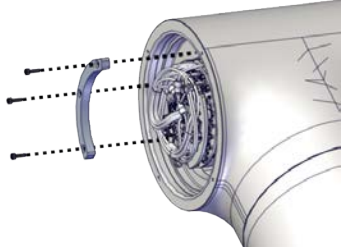

Continued

	Action	Note
3	 CAUTION Valid for CRB 15000-5/0.95 There is cabling connected between the cover and the joint unit drive board. Open the cover with care to avoid damage to the cabling or the connector(s). Do not leave the cover in location without being secured with the attachment screws.	
4	Remove the insert.	 xx2300000815

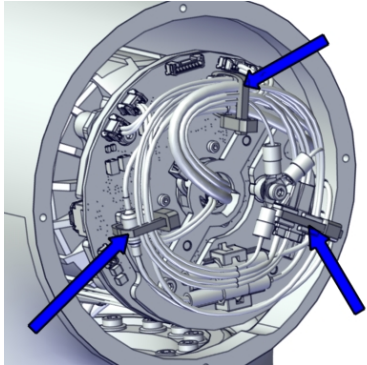

Disconnecting the axis-2 joint unit cabling

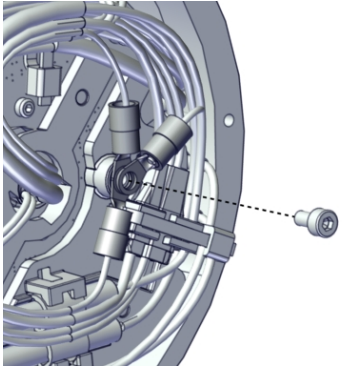
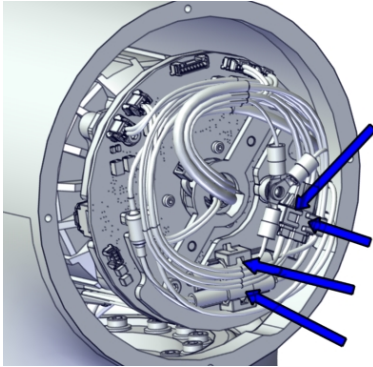
	Action	Note
1	 ELECTROSTATIC DISCHARGE (ESD) The unit is sensitive to ESD. Before handling the unit read the safety information in section The unit is sensitive to ESD on page 53 .	
2	Cut the cable ties.	 xx2000001946

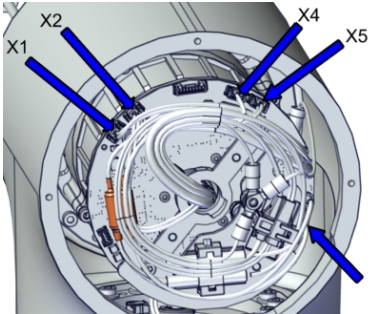
Continues on next page

	Action	Note
3	Remove the functional and protective earth cables by removing the screw.	 <p>xx2000001945</p>
4	Snap loose and disconnect the connectors: <ul style="list-style-type: none"> • J2.DC+ • J2.DC- • J2.CS • J2.CP 	 <p>xx2000001944</p>
5	Disconnect the connectors from the drive board. <ul style="list-style-type: none"> • D2.X1 from X1 • D2.DC+ from DC+ • D2.DC- from ground • D2.X4 from X4 • D2.X2 from X2 • D2.X5 from X5 <p> CAUTION</p> <p>Use tweezers to unlock connectors and pull them off.</p>	 <p>xx2000002013</p>

Removing the base from foundation (-10/1.52 and -12/1.27)



	Action	Note
1	<p> CAUTION</p> <p>The weight of the complete swing and base together is up to 25 kg</p>	
2	<p> WARNING</p> <p>Personnel must not, under any circumstances, be present under the suspended load.</p>	

Continues on next page

5 Repair

5.5.2 Replacing the swing

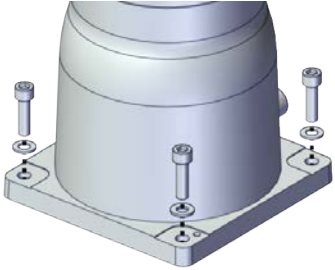

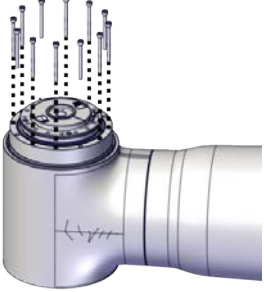

Continued

	Action	Note
3	Loosen the robot base from the foundation by removing the foundation attachment screws.	 <p>xx2300001060</p>
4	<p>Lay the robot down with the torque sensor side upwards on a working bench. Do not damage the base socket. Caution with the cabling.</p> <p> CAUTION</p> <p>The cabling is sensitive to mechanical damage. Handle it with care to avoid damage to the cabling or the connector, avoid any kind of tilt or skew.</p>	

Removing the axis-2 joint unit

	Action	Note
1	Removing the attachment screws.	 <p>xx2300000786</p>

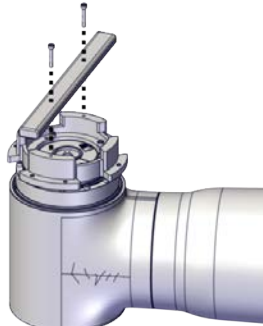
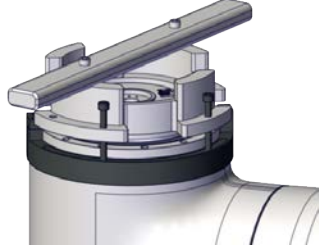
Continues on next page

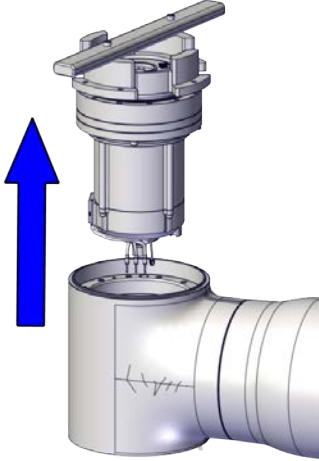
	Action	Note
2	<p>Fit the lifting aid to the joint unit, on the torque sensor side.</p> <p> CAUTION</p> <p>The connectors and the joint unit cables are sensitive to mechanical damage. Handle the assembly with care.</p>	<p>Lifting aid: 3HAC087787-001 Screws: M5x30 (4 pcs for plate and 2 pcs for beam)</p>  
3	<p>Place the two semicircular blocks surrounding the joint unit, and use two fully threaded attachment screws as removal tools to press the joint unit out of position.</p>	
4	<p>Remove the joint unit from the swing.</p> <p> CAUTION</p> <p>The connectors and the joint unit cables are sensitive to mechanical damage. Handle the assembly with care.</p>	

Continues on next page

5 Repair

5.5.2 Replacing the swing

Continued

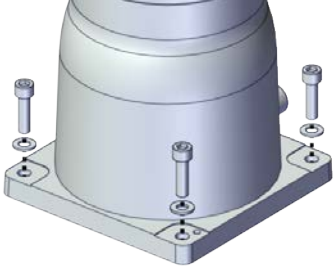

	Action	Note
5	Remove the lifting aid.	 <p data-bbox="1029 645 1136 667">xx230000778</p> <p data-bbox="1029 1021 1136 1043">xx230000776</p>

Securing the base (-10/1.52 and -12/1.27)

	Action	Note
1	Lift the base to standing and secure it to the foundation with the attachment screws and washers.	<p data-bbox="992 1193 1374 1249">Attachment screws: M10x35 8.8 (4 pcs).</p> <p data-bbox="992 1254 1406 1288">Washers: 23/10.5/2.5 mm Steel (4 pcs).</p> <p data-bbox="992 1292 1353 1326">Tightening torque: 32 Nm \pm10%.</p>  <p data-bbox="992 1619 1102 1641">xx2300001060</p>

Continues on next page

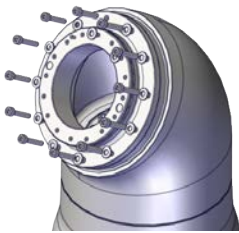
Removing the swing (-10/1.52 and -12/1.27)

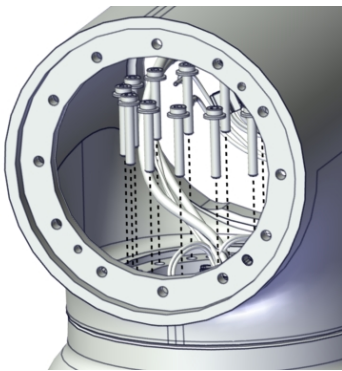

	Action	Note
1	<p>Valid for CRB 15000-10/1.52 Remove the swing transition.</p>	 <p>xx2300000817</p>
2	<p>Valid for CRB 15000-10/1.52 Remove the swing flange.</p>	 <p>xx2300000818</p>
3	<p>Remove the swing attachment screws.</p> <p> CAUTION</p> <p>Do not mix the flange screws used for CRB 15000-5/0.95 and the threaded screws used for CRB 15000-10/1.52 and CRB 15000-12/1.27. Always use washers together with the threaded screws for CRB 15000-10/1.52 and CRB 15000-12/1.27. Illustration is for reference only.</p>	<p>Valid for CRB 15000-10/1.52</p>  <p>xx2300000819</p> <p>Valid for CRB 15000-12/1.27</p>  <p>xx2000001987</p>

Continues on next page

5 Repair

5.5.2 Replacing the swing

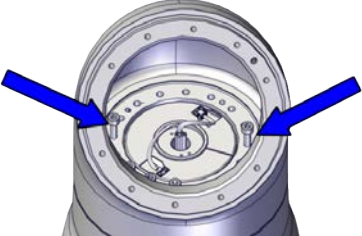
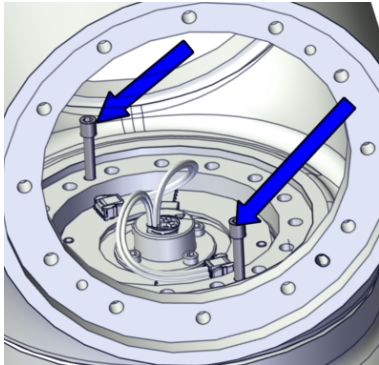
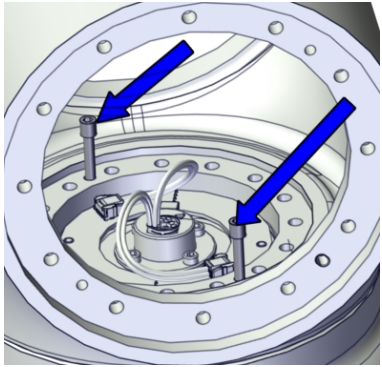
Continued

	Action	Note
4	<p>Use two fully threaded attachment screws as removal tools to press the swing out of position.</p> <p> CAUTION</p> <p>Do not mix the flange screws used for CRB 15000-5/0.95 and the threaded screws used for CRB 15000-10/1.52 and CRB 15000-12/1.27. Always use washers together with the threaded screws for CRB 15000-10/1.52 and CRB 15000-12/1.27. Illustration is for reference only.</p>	<p>Valid for CRB 15000-10/1.52</p>  <p>xx2300000822</p> <p>Valid for CRB 15000-12/1.27</p>  <p>xx2000002152</p>
5	<p>Lift away the swing.</p> <p> CAUTION</p> <p>The torque sensor (on the exposed PCBA) is sensitive to mechanical damage. Handle the assembly with care.</p>	



Refitting the swing (-5/0.95)

Use these procedures to refit the swing.

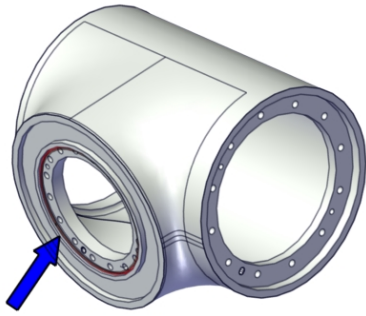
Refitting the swing(-5/0.95)

	Action	Note
1	<p>Clean the mounting surface with isopropanol. Apply flange sealant to the corner of the base mounting surface, as pointed out in the figure.</p>	<p>Cleaning agent: Isopropanol Flange sealant: Loctite 574</p>  <p>xx2000001990</p>

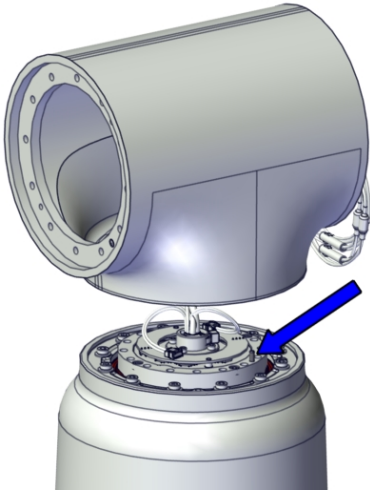
Continues on next page

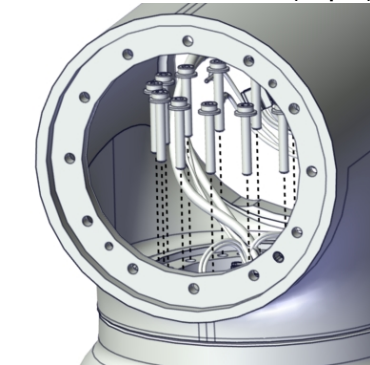
	Action	Note
2	Separate the new swing parts by removing the pre-assembling screws.	
3	<p>Refit the swing to the base unit, aligning the pin with the pin hole.</p> <p> CAUTION</p> <p>The torque sensor (on the exposed PCBA) is sensitive to mechanical damage. Handle the assembly with care.</p>	 <p>xx2000001989</p>
4	<p>Secure the swing with the attachment screws. Pre-tighten the screws crosswise firstly.</p> <p> CAUTION</p> <p>Do not mix the flange screws used for CRB 15000-5/0.95 and the threaded screws used for CRB 15000-10/1.52 and CRB 15000-12/1.27. Always use washers together with the threaded screws for CRB 15000-10/1.52 and CRB 15000-12/1.27. Illustration is for reference only.</p>	<p>Hex socket head cap flange screw: M4x25 12.9 Lafre 2C2B/FC6.9+PrO-COat111 (16 pcs)</p>  <p>xx2000001987</p>
5	Torque tighten all screws crosswise.	Tightening torque: 4.6 Nm

Preparations before fitting the joint unit (-5/0.95)



	Action	Note
1	<p> ELECTROSTATIC DISCHARGE (ESD)</p> <p>The unit is sensitive to ESD. Before handling the unit read the safety information in section The unit is sensitive to ESD on page 53.</p>	

Continues on next page



5 Repair

5.5.2 Replacing the swing

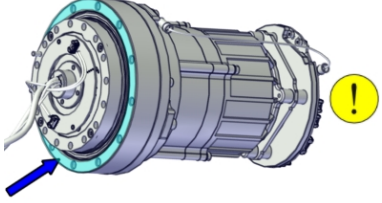



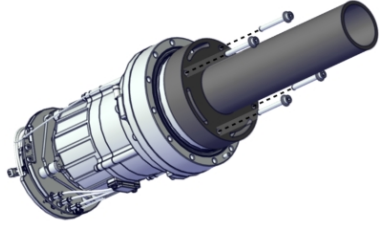

Continued

	Action	Note
2	Clean the mounting surface of the joint unit and the mating surface on the casting with isopropanol. Joint unit mounting surface is pointed out in the figure.	Cleaning agent: Isopropanol Flange sealant: Loctite 574
3	Apply a thin layer of flange sealant to the mounting surface. Do not contaminate the radial sealing with sealant.  CAUTION The connectors and the joint unit cables are sensitive to mechanical damage. Handle the assembly with care.  ELECTROSTATIC DISCHARGE (ESD) The unit is sensitive to ESD. Before handling the unit read the safety information in section The unit is sensitive to ESD on page 53 .	 xx2000001860

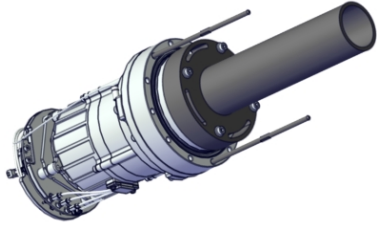
Refitting the axis-2 joint unit (-5/0.95)

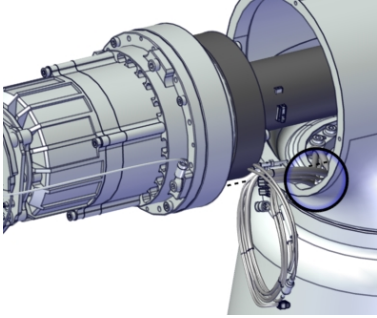
	Action	Note
1	 ELECTROSTATIC DISCHARGE (ESD) The unit is sensitive to ESD. Before handling the unit read the safety information in section The unit is sensitive to ESD on page 53 .	
2	Fit the lifting aid to the joint unit.  CAUTION The connectors and the joint unit cables are sensitive to mechanical damage. Handle the assembly with care.	Joint unit: 3HAC079141-001 Lifting aid: 3HAC077788-001 Screws: M4x35 (4 pcs)  xx2000001957

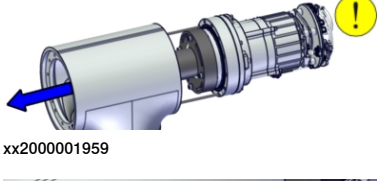
Continues on next page

	Action	Note
3	Fit two guide pins to the joint unit.	<p>Guide pin, M4x120: 3HAC077786-001</p> <p>Always use guide pins in pairs.</p> <p>For joint units on axes 1, 2 and 3 of CRB 15000-5/0.95 and axis 3 of CRB 15000-10/1.52 and CRB 15000-12/1.27.</p>  <p>xx2000002438</p>
4	<p>Place the axis-1 cabling at the notch in the swing.</p> <p> CAUTION</p> <p>The cabling is sensitive to mechanical damage. Handle it with care to avoid damage to the cabling or the connector, avoid any kind of tilt or skew.</p>	 <p>xx2000002153</p>
5	<p>Fit the joint unit to the swing, aligning the pin with the pin hole.</p> <p> CAUTION</p> <p>The connectors and the joint unit cables are sensitive to mechanical damage. Handle the assembly with care.</p>	 <p>xx2000001959</p>  <p>xx2000001961</p>

Continues on next page

5 Repair

5.5.2 Replacing the swing

Continued

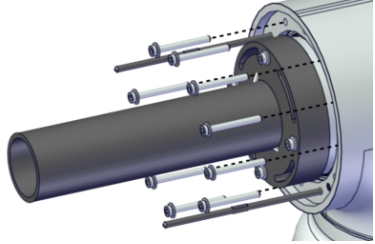
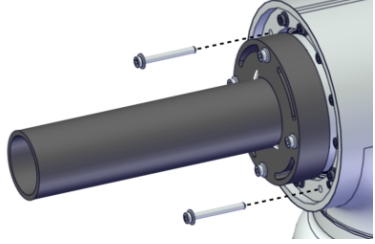
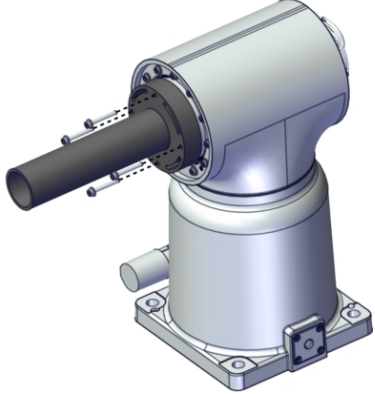
	Action	Note
6	Secure the joint unit with new attachment screws.	<p>Flange socket head screw with glue: 3HAB3413-435 M4x35 12.9 Lafre 2C2B/FC6.9+PrO-COat111, with NYPLAS glue , 12 pcs Used for joint unit of CRB 15000-5/0.95.</p> <p>Always use new screws when refitting a joint unit. If ordering a new joint unit spare part, new screws are included.</p>  <p>xx2000001943</p>
7	Remove the guide pins and secure the remaining two attachment screws.	 <p>xx2100000295</p>
8	Pre-tighten the screws crosswise.	
9	Torque tighten all screws crosswise.	Tightening torque: 4.3 Nm.
10	Remove the lifting aid by removing the screws.	 <p>xx2000001956</p>
11	Clean pushed-out flange sealant, if any.	

Continues on next page

Connecting the axis-2 joint unit cabling

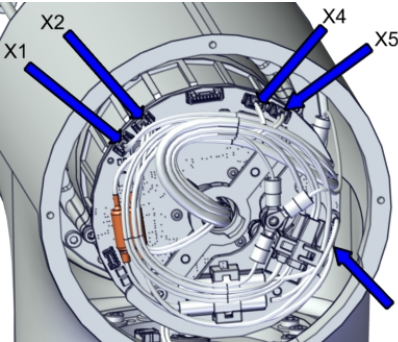
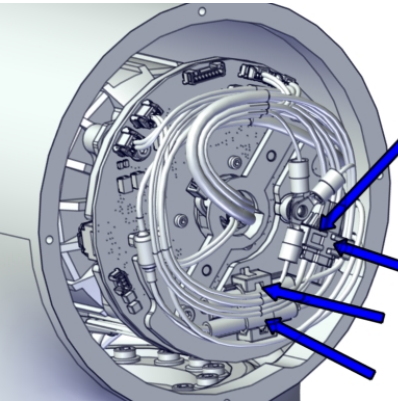
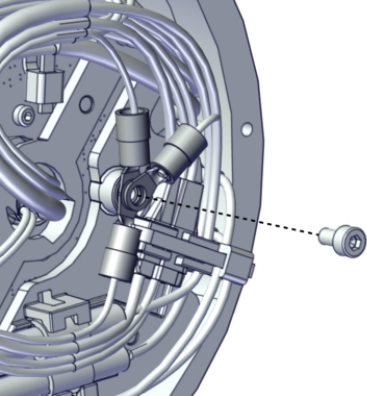
	Action	Note
1	 ELECTROSTATIC DISCHARGE (ESD) The unit is sensitive to ESD. Before handling the unit read the safety information in section <i>The unit is sensitive to ESD on page 53.</i>	
2	Reconnect the connectors to the drive board. <ul style="list-style-type: none"> • D2.X1 to X1 • D2.DC+ to DC+ • D2.DC- to Ground • D2.X4 to X4 • D2.X2 to X2 • D2.X5 to X5 	 <p>xx2000002013</p>
3	Connect the connectors to each other and snap them to the cable holders. <ul style="list-style-type: none"> • J2.DC+ to J2.DC+ • J2.DC- to J2.DC- • J2.CS to J2.CS • J2.CP to J2.CP 	 <p>xx2000001944</p>
4	Secure the cables for functional earth and protective earth with a screw.	Hex socket head cap screw: M3x6 (1 pcs). Tightening torque: 0.8 Nm.  <p>xx2000001945</p>

Continues on next page

5 Repair

5.5.2 Replacing the swing

Continued

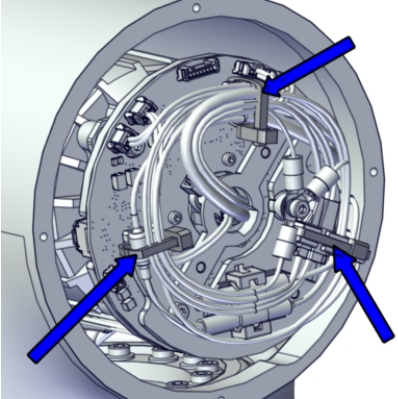
	Action	Note
5	Secure the cabling with cable ties.	Cable ties (3 pcs)  <small>xx2000001946</small>

Refitting the swing cover(-5/0.95)

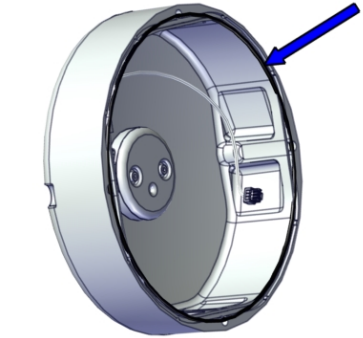
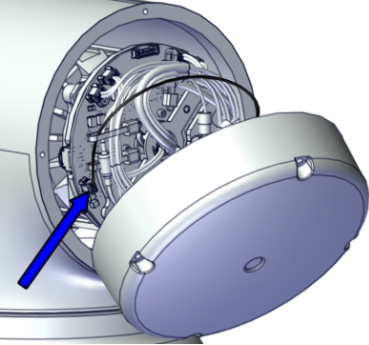
	Action	Note
1	Fit the o-ring to cover groove. Replace if damaged.	O-ring: 3HAC061327-047 (for CRB 15000-5/0.95)  <small>xx2000001962</small>
2	For robots with RobotWare earlier than 7.10 Place the cover at mounting position and reconnect the brake release connector DR.X8 to the drive board. Orient the cover for proper arrangement of the brake release cable.	 <small>xx2000001932</small>

Continues on next page

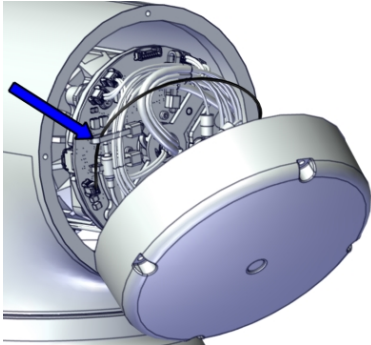
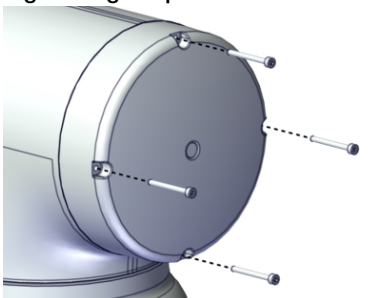
	Action	Note
3	<p>For robots with RobotWare earlier than 7.10 Secure the brake release cable with a cable tie.</p>	<p>Cable ties</p>  <p>xx2000001931</p>
4	<p>Refit the cover with the four screws.</p>	<p>Hex socket head cap screw: M3x30 12.9 Lafre 2C2B/FC6.9 (4 pcs) Tightening torque: 0.45 Nm</p>  <p>xx2000001935</p>

Refitting the lower and upper arm assembled (-5/0.95)

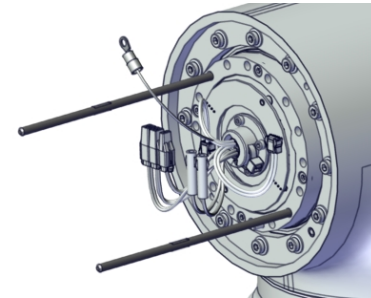



	Action	Note
1	<p>Fit two guide pins to the axis-2 joint unit.</p>	<p>Guide pin, M4x120: 3HAC077786-001</p>  <p>xx2000001949</p>

Continues on next page

5 Repair

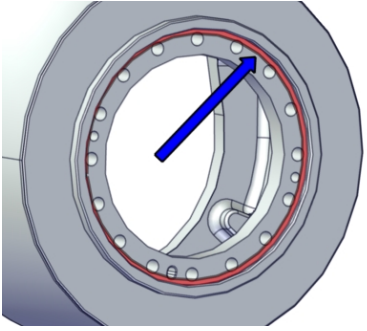
5.5.2 Replacing the swing

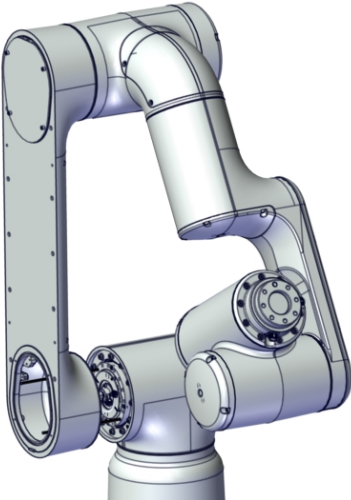
Continued

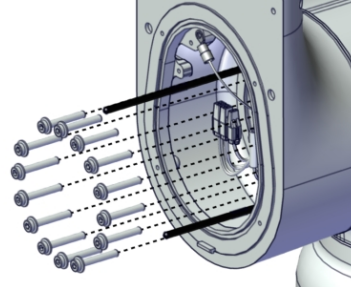
	Action	Note
2	<p>Remove any old residuals of flange sealant from the lower arm mounting surface and clean with isopropanol.</p> <p>Apply new flange sealant to the corner of the lower arm mounting surface, as pointed out in the figure.</p>	<p>Cleaning agent: Isopropanol Flange sealant: Loctite 574</p>  <p>xx2000001963</p>
3	<p> CAUTION</p> <p>The weight of the complete upper and lower arm together is 18 kg</p>	
4	<p>Lift the upper and lower arm assembly to mounting position and slide it onto the guide pins.</p>	 <p>xx2000001941</p>
5	<p>Secure the lower arm to the swing with all attachment screws but two.</p> <p>Pre-tighten the screws crosswise firstly.</p> <p> CAUTION</p> <p>Do not mix the flange screws used for CRB 15000-5/0.95 and the threaded screws used for CRB 15000-10/1.52 and CRB 15000-12/1.27. Always use washers together with the threaded screws for CRB 15000-10/1.52 and CRB 15000-12/1.27. Illustration is for reference only.</p>	<p>Hex socket head cap flange screw: M4x25 12.9 Lafre 2C2B/FC6.9+PrO-COat111 (16 pcs)</p>  <p>xx2000001940</p>

Continues on next page

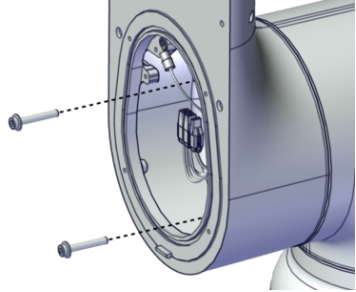
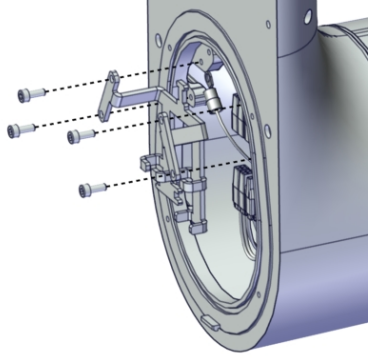
	Action	Note
6	<p>Remove the guide pins and fasten the remaining two screws.</p> <p> CAUTION</p> <p>Do not mix the flange screws used for CRB 15000-5/0.95 and the threaded screws used for CRB 15000-10/1.52 and CRB 15000-12/1.27. Always use washers together with the threaded screws for CRB 15000-10/1.52 and CRB 15000-12/1.27. Illustration is for reference only.</p>	<p>Hex socket head cap flange screw: M4x25 12.9 Lafre 2C2B/FC6.9+PrO-COat111 (16 pcs)</p>  <p>xx2000001951</p>
7	Torque tighten all screws crosswise.	Tightening torque: 4.6 Nm
8	Refit the cable bracket with four screws.	<p>Hex socket head cap screw: M3x8 12.9 Lafre 2C2B/FC6.9 (4 pcs). Tightening torque: 0.8 Nm</p>  <p>xx2000001939</p>

Connecting the cabling between the lower arm and swing

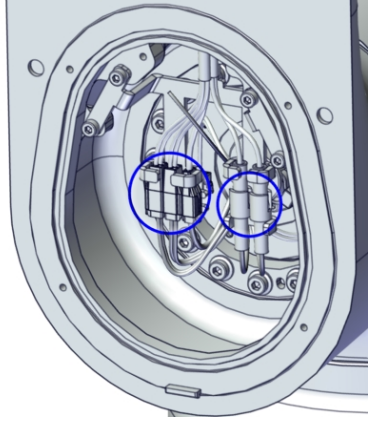
	Action	Note
1	Connect the connectors to each other and snap them to the cable holders.	 <p>xx2000001938</p>

Continues on next page

5 Repair

5.5.2 Replacing the swing

Continued

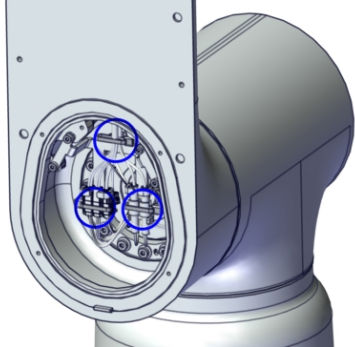
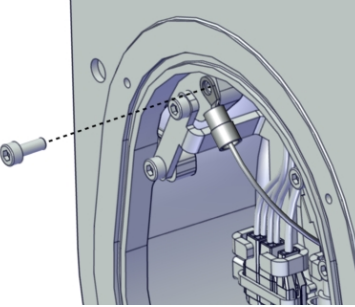
	Action	Note
2	Secure the cabling with cable ties.	<p>Cable ties (3 pcs)</p>  <p>xx2000001937</p>
3	Connect the functional earth cable with the screw.	<p>Hex socket head cap screw: M3x8 12.9 Lafre 2C2B/FC6.9 (1 pcs). Tightening torque: 0.8 Nm</p>  <p>xx2000001936</p>

Refitting the lower arm covers (-5/0.95)

	Action	Note
1	Wipe, lubricate and fit the o-ring to its groove. Replace if damaged.	<p>O-ring: 3HAC061327-044 Grease: 3HAC042536-001 (Shell Gadus S2)</p>  <p>xx2000001954</p>

Continues on next page

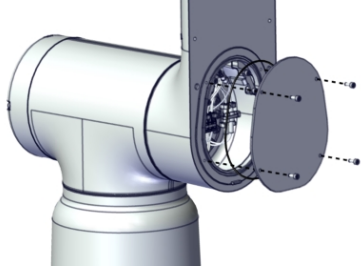
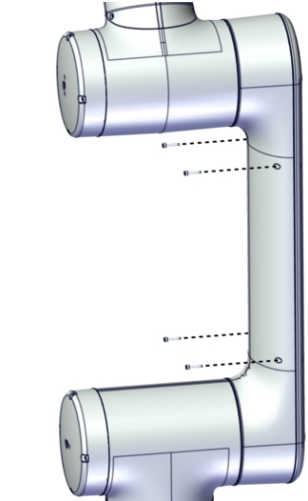
	Action	Note
2	Refit the inner cover with four screws.	<p>Hex socket head cap screw: M3x8 12.9 Lafre 2C2B/FC6.9 (4 pcs) Tightening torque: 1.4 Nm.</p>  <p>xx2000001930</p>
3 4	<p>3 Snap the lower arm cover into place.</p> <p>4 Secure the cover with four screws.</p>	<p>Hex socket head cap screw: M3x16 12.9 Lafre 2C2B/FC6.9 (4 pcs) Tightening torque: 0.45 Nm.</p>  <p>xx2000001929</p>

Concluding procedure

	Action	Note
1	Calibrate the joint unit torque sensor for the axis-2 joint unit.	See Calibration on page 1063
2	 <p>DANGER</p> <p>Make sure all safety requirements are met when performing the first test run. See Test run after installation, maintenance, or repair on page 90.</p>	

Continues on next page

5 Repair

5.5.2 Replacing the swing

Continued

Refitting the swing (-10/1.52 and -12/1.27)

Use these procedures to refit the swing.

Refitting the swing(-10/1.52 and -12/1.27)

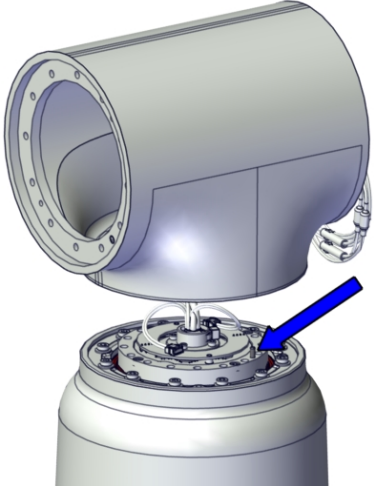
	Action	Note
1	Fit two guide pins on the base unit for position guidance. Always use guide pins in pairs.	Valid for CRB 15000-10/1.52 Guide pin, M5x75, 3HAC087786-002 Valid for CRB 15000-12/1.27 Guide pin, M5x125: 3HAC087786-001
2	Refit the swing to the base unit, aligning the pin with the pin hole.  CAUTION The torque sensor (on the exposed PCBA) is sensitive to mechanical damage. Handle the assembly with care.	Example of CRB 15000-12/1.27, similar to CRB 15000-10/1.52.  xx2000001989

Continues on next page

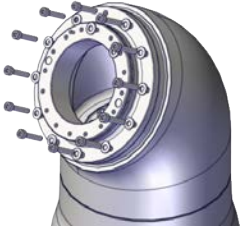

	Action	Note
3	<p>Secure the swing with the attachment screws.</p> <p> CAUTION</p> <p>Do not mix the flange screws used for CRB 15000-5/0.95 and the threaded screws used for CRB 15000-10/1.52 and CRB 15000-12/1.27. Always use washers together with the threaded screws for CRB 15000-10/1.52 and CRB 15000-12/1.27. Illustration is for reference only.</p>	<p>Hex socket head cap screw: M5x30 12.9 Lafre 2C2B/FC6.9 (16 pcs) Tightening torque: 8.2 Nm Valid for CRB 15000-12/1.27</p>  <p>xx2000001987</p> <p>Valid for CRB 15000-10/1.52</p>  <p>xx2300000819</p>
4	<p>Valid for CRB 15000-10/1.52</p> <p>Check the o-rings on both side of the swing flange. Replace if damaged.</p>	<p>O-ring: 3HAC061327-073 O-ring: 3HAC061327-044</p>  <p>xx2300000821</p>
5	<p>Valid for CRB 15000-10/1.52</p> <p>Refit the swing flange with the attachment screws. Always check the serial number printed on the swing parts and use the parts in the same number for refitting.</p> <p> CAUTION</p> <p>Do not use the pre-assembling screws of swing parts for securing.</p>	<p>Hex socket head cap screw: M5x25 12.9 Lafre 2C2B/FC6.9 (16 pcs) Tightening torque: 8.2 Nm</p>  <p>xx2300000818</p>

Continues on next page

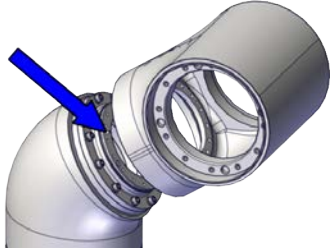

5 Repair

5.5.2 Replacing the swing

Continued

	Action	Note
6	<p>Valid for CRB 15000-10/1.52</p> <p>Fit two guide pins on the swing flange for position guidance.</p> <p>Always use guide pins in pairs.</p>	<p>Guide pin, M5x75, 3HAC087786-002</p>
7	<p>Valid for CRB 15000-10/1.52</p> <p>Refit the swing transition to the swing flange, aligning the pin with the pin hole.</p> <p>Always check the serial number printed on the swing parts and use the parts in the same number for refitting.</p>	 <p>xx2300000820</p>
8	<p>Valid for CRB 15000-10/1.52</p> <p>Secure the swing transition with the attachment screws.</p> <p> CAUTION</p> <p>Do not use the pre-assembling screws of swing parts for securing.</p>	<p>Hex socket head cap screw: M5x25 12.9 Lafre 2C2B/FC6.9 (16 pcs)</p> <p>Tightening torque: 8.2 Nm</p>  <p>xx2300000817</p>

Removing the base from foundation (-10/1.52 and -12/1.27)

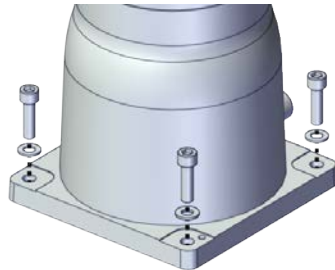
	Action	Note
1	<p> CAUTION</p> <p>The weight of the swing and base together is up to 16.7 kg</p>	
2	<p> WARNING</p> <p>Personnel must not, under any circumstances, be present under the suspended load.</p>	
3	<p>Loosen the robot base from the foundation by removing the foundation attachment screws.</p>	 <p>xx2300001060</p>

Continues on next page

	Action	Note
4	<p>Lay the robot down with the side that axis-2 torque sensor will be upwards on a working bench. Do not damage the base socket. Caution with the cabling.</p> <p> CAUTION</p> <p>The cabling is sensitive to mechanical damage. Handle it with care to avoid damage to the cabling or the connector, avoid any kind of tilt or skew.</p>	

Refitting the axis-2 joint unit (-10/1.52 and -12/1.27)

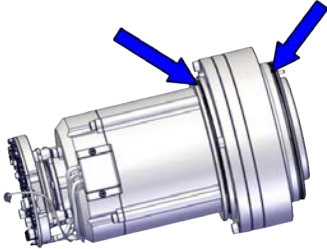
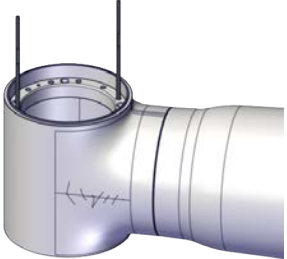

	Action	Note
1	<p> ELECTROSTATIC DISCHARGE (ESD)</p> <p>The unit is sensitive to ESD. Before handling the unit read the safety information in section The unit is sensitive to ESD on page 53.</p>	
2	<p>Check the o-rings. Replace if damaged.</p>	<p>O-ring: 3HAC061327-044</p>  <p>xx2300000823</p>
3	<p>Fit two guide pins to the swing.</p>	<p>Guide pin, M5x125: 3HAC087786-001</p> <p>Always use guide pins in pairs.</p> <p>For joint units on axes 1 and 2 of CRB 15000-10/1.52 and CRB 15000-12/1.27.</p>  <p>xx2300000791</p>

Continues on next page

5 Repair

5.5.2 Replacing the swing

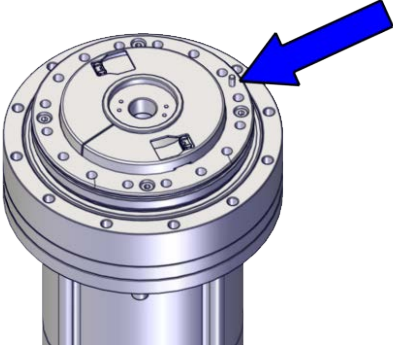
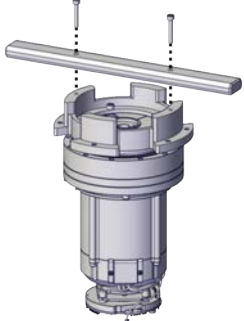
Continued

	Action	Note
4	<p>Fit the lifting aid to the joint unit, aligning the pin with the pin hole.</p> <p> CAUTION</p> <p>The connectors and the joint unit cables are sensitive to mechanical damage. Handle the assembly with care.</p>  <p>xx2300000777</p>	<p>Joint unit: 3HAC087472-001 Lifting aid: 3HAC087787-001 Screws: M5x30 (4 pcs for plate and 2 pcs for beam)</p>  <p>xx2300000778</p>  <p>xx2300000776</p>
5	<p>Place the axis-1 cabling properly to avoid squeezing by the joint unit when putting the joint unit into the swing.</p> <p> CAUTION</p> <p>The cabling is sensitive to mechanical damage. Handle it with care to avoid damage to the cabling or the connector, avoid any kind of tilt or skew.</p>	

Continues on next page

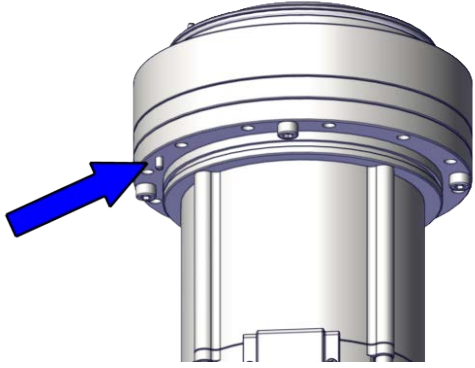
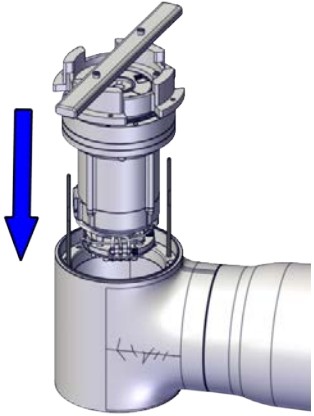
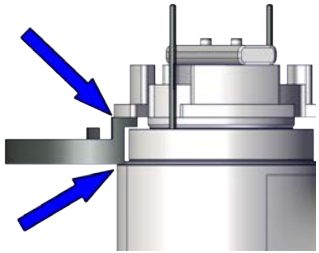
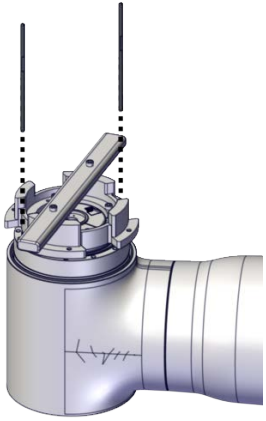
	Action	Note
6	<p>Fit the joint unit to the swing, aligning the pin with the pin hole.</p> <p> CAUTION</p> <p>The connectors and the joint unit cables are sensitive to mechanical damage. Handle the assembly with care.</p>  <p>xx2300000780</p>	 <p>xx2300000792</p>
7	<p>Check the joint unit position by placing the higher boss of one semicircular block between the lifting aid and swing.</p> <p>The joint unit is properly placed when no gaps between the block and both lifting aid and swing.</p>	 <p>xx2300000794</p>
8	<p>Remove the guide pins.</p>	 <p>xx2300000795</p>

Continues on next page

5 Repair

5.5.2 Replacing the swing

Continued

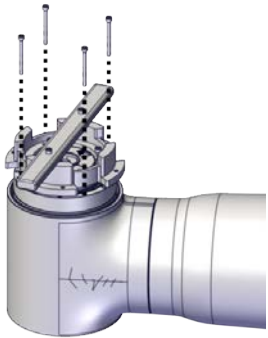
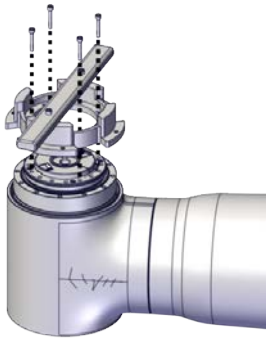
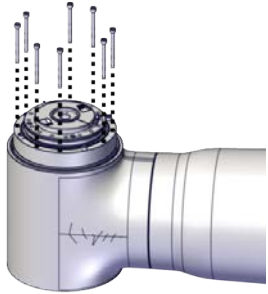
	Action	Note
9	Secure with four attachment screws and pre-tighten the screws crosswise.	 <p data-bbox="1029 674 1136 689">xx2300000796</p>
10	Remove the lifting aid by removing the screws.	 <p data-bbox="1029 1088 1136 1104">xx2300000797</p>
11	Secure the joint unit with the remaining attachment screws.	<p data-bbox="1029 1144 1342 1196">Hex socket head cap screw: 3HAB3409-20</p>  <p data-bbox="1029 1525 1136 1541">xx2300000798</p>
12	Torque tighten all screws crosswise.	<p data-bbox="1029 1581 1404 1668">M5x55 12.9 Lafre 2C2B/FC6.9, 12 pcs Tightening torque: 8.2 Nm.</p>

Continues on next page

Securing the base (-10/1.52 and -12/1.27)

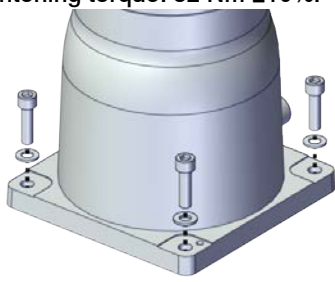
	Action	Note
1	Lift the base to standing and secure it to the foundation with the attachment screws and washers.	<p>Attachment screws: M10x35 8.8 (4 pcs). Washers: 23/10.5/2.5 mm Steel (4 pcs). Tightening torque: 32 Nm ±10%.</p>  <p>xx2300001060</p>

Connecting the axis-2 joint unit cabling

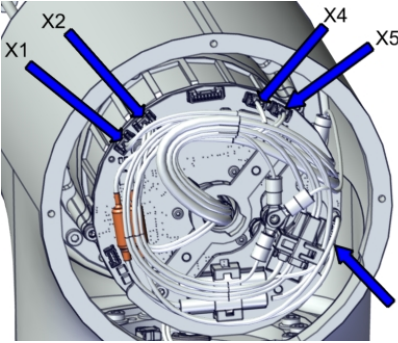
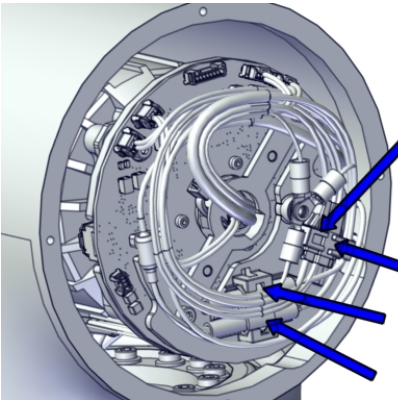
	Action	Note
1	 <p>ELECTROSTATIC DISCHARGE (ESD)</p> <p>The unit is sensitive to ESD. Before handling the unit read the safety information in section The unit is sensitive to ESD on page 53.</p>	
2	<p>Reconnect the connectors to the drive board.</p> <ul style="list-style-type: none"> • D2.X1 to X1 • D2.DC+ to DC+ • D2.DC- to Ground • D2.X4 to X4 • D2.X2 to X2 • D2.X5 to X5 	 <p>xx2000002013</p>
3	<p>Connect the connectors to each other and snap them to the cable holders.</p> <ul style="list-style-type: none"> • J2.DC+ to J2.DC+ • J2.DC- to J2.DC- • J2.CS to J2.CS • J2.CP to J2.CP 	 <p>xx2000001944</p>

Continues on next page

5 Repair

5.5.2 Replacing the swing

Continued

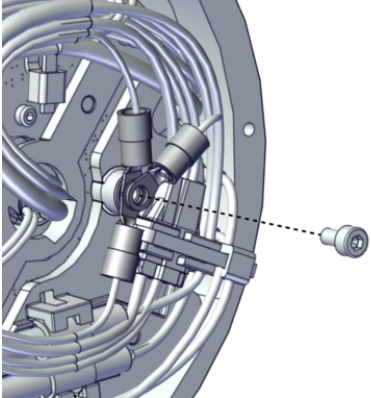
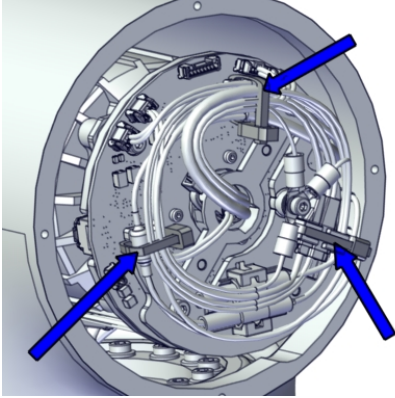
	Action	Note
4	Secure the cables for functional earth and protective earth with a screw.	<p>Hex socket head cap screw: M3x6 (1 pcs).</p> <p>Tightening torque: 0.8 Nm.</p>  <p>xx2000001945</p>
5	Secure the cabling with cable ties.	<p>Cable ties (3 pcs)</p>  <p>xx2000001946</p>

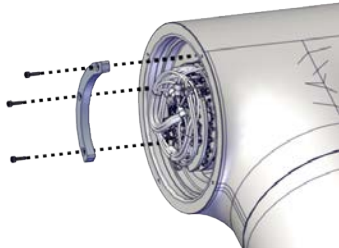

Refitting the swing cover and insert(-10/1.52 and -12/1.27)

	Action	Note
1	Refit the insert.	<p>Insert: 3HAC084002-001</p> <p>Hex socket head cap screw: M3x10</p> <p>12.9 Lafre 2C2B/FC6.9 (3 pcs)</p> <p>Tightening torque: 1.4 Nm</p>  <p>xx2300000815</p>

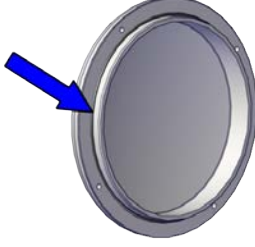
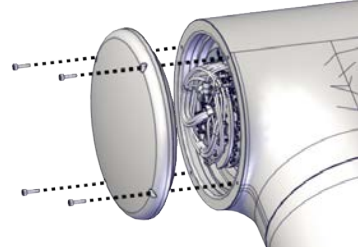
Continues on next page

	Action	Note
2	Fit the o-ring to cover groove. Replace if damaged.	O-ring: 3HAC061327-074 (for CRB 15000-10/1.52 and CRB 15000-12/1.27)  xx2300000816
3	Refit the cover with the four screws.	Hex socket head cap screw: M3x12 12.9 Lafre 2C2B/FC6.9 (4 pcs) Tightening torque: 1.4 Nm  xx2300000814

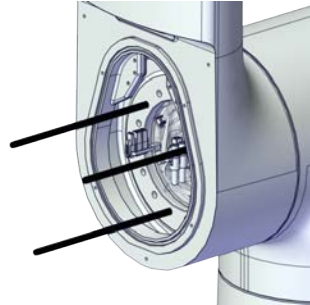
Refitting the lower and upper arm assembled (-10/1.52 and -12/1.27)





	Action	Note
1	Fit three guide pins to the axis-2 joint unit.	Guide pin, M5x125: 3HAC087786-001  xx2300001021
2	 CAUTION The weight of the complete upper and lower arm together is up to 26 kg	

Continues on next page

5 Repair

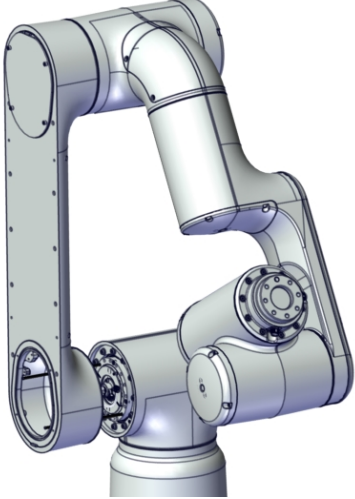
5.5.2 Replacing the swing

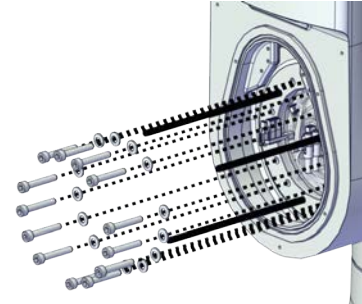
Continued

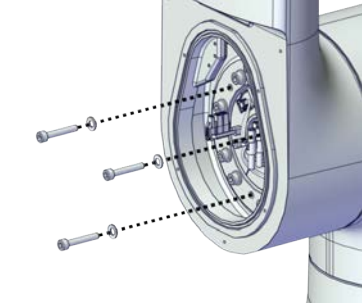
	Action	Note
3	Lift the upper and lower arm assembly to mounting position and slide it onto the guide pins.	<p>Example of CRB 15000-5/0.95, similar to CRB 15000-10/1.52 and CRB 15000-12/1.27.</p>  <p>xx2000001941</p>
4	<p>Secure the lower arm to the swing with all screws and washers but two.</p> <p>Pre-tighten the screws crosswise firstly.</p> <p> CAUTION</p> <p>Do not mix the flange screws used for CRB 15000-5/0.95 and the threaded screws used for CRB 15000-10/1.52 and CRB 15000-12/1.27. Always use washers together with the threaded screws for CRB 15000-10/1.52 and CRB 15000-12/1.27. Illustration is for reference only.</p>	<p>Hex socket head cap screw: M5x30 12.9 Lafre 2C2B/FC6.9, 16 pcs</p>  <p>xx2300001022</p>
5	<p>Remove the guide pins and fasten the remaining two screws and washers.</p> <p> CAUTION</p> <p>Do not mix the flange screws used for CRB 15000-5/0.95 and the threaded screws used for CRB 15000-10/1.52 and CRB 15000-12/1.27. Always use washers together with the threaded screws for CRB 15000-10/1.52 and CRB 15000-12/1.27. Illustration is for reference only.</p>	<p>Hex socket head cap screw: M5x30 12.9 Lafre 2C2B/FC6.9, 16 pcs</p>  <p>xx2300001023</p>
6	Torque tighten all screws crosswise.	Tightening torque: 8.2 Nm

Continues on next page

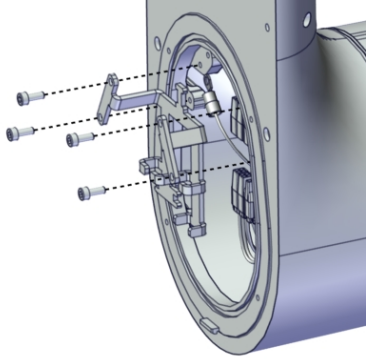
	Action	Note
7	Refit the cable bracket with four screws.	<p>Hex socket head cap screw: M3x8 12.9 Lafre 2C2B/FC6.9 (4 pcs). Tightening torque: 0.8 Nm</p>  <p>xx2000001939</p>

Connecting the cabling between the lower arm and swing

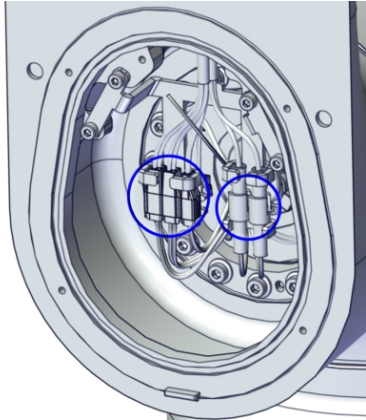
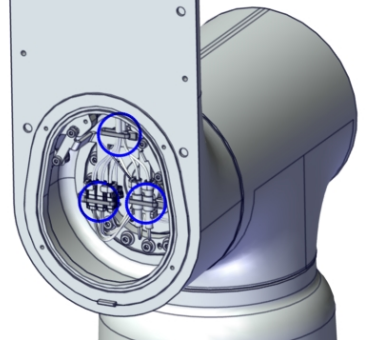
	Action	Note
1	Connect the connectors to each other and snap them to the cable holders.	 <p>xx2000001938</p>
2	Secure the cabling with cable ties.	<p>Cable ties (3 pcs)</p>  <p>xx2000001937</p>

Continues on next page

5 Repair

5.5.2 Replacing the swing

Continued

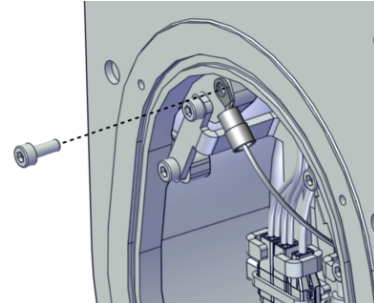
	Action	Note
3	Connect the functional earth cable with the screw.	<p>Hex socket head cap screw: M3x8 12.9 Lafre 2C2B/FC6.9 (1 pcs). Tightening torque: 0.8 Nm</p>  <p>xx2000001936</p>

Refitting the lower arm covers (-10/1.52 and -12/1.27)

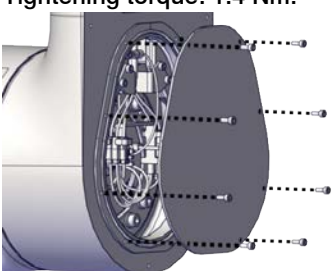
	Action	Note
1	Wipe, lubricate and fit the o-ring to its groove. Replace if damaged.	<p>O-ring: 3HAC061327-075 Grease: 3HAC042536-001 (Shell Gadus S2)</p>  <p>xx2000001954</p>
2	Refit the inner cover with four screws.	<p>Hex socket head cap screw: M3x8 12.9 Lafre 2C2B/FC6.9 (4 pcs) Tightening torque: 1.4 Nm.</p>  <p>xx2300000813</p>

Continues on next page

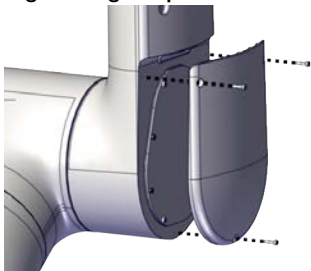
	Action	Note
3	Refit the lower cover of lower arm with three screws.	<p>Lower arm cover, lower: Lower arm, used for CRB 15000-10/1.52 and CRB 15000-12/1.27. Tightening torque: 1.4 Nm.</p>  <p>xx2300000812</p>

Concluding procedure

	Action	Note
1	Calibrate the joint unit torque sensor for the axis-2 joint unit.	See Calibration on page 1063
2	 DANGER Make sure all safety requirements are met when performing the first test run. See Test run after installation, maintenance, or repair on page 90 .	

5 Repair

5.6.1 Replacing the axis-1 joint unit (CRB 15000-5/0.95)

5.6 Joint units

5.6.1 Replacing the axis-1 joint unit (CRB 15000-5/0.95)

Location of the axis-1 joint unit

The joint unit is located as shown in the figure.

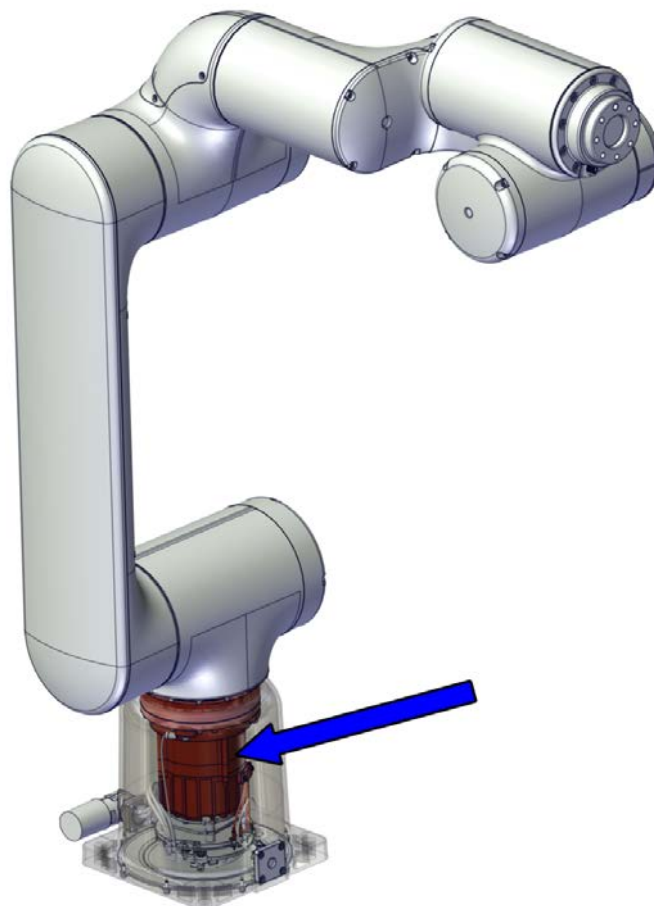

xx2000002018

Summary of the replacement procedure

This is a brief summary of the replacement procedure, containing the major actions to be performed.

- 1 Separate the cabling between the swing and the lower arm.
- 2 Remove the lower and upper arm undivided.
- 3 Remove the axis-2 joint unit.
- 4 Remove the swing.
- 5 Loosen the base from the foundation and lay it down on its side.
- 6 Replace the axis-1 joint unit. Move the cabling from old to new joint unit.

Continues on next page

Required spare parts



Note

The spare part numbers that are listed in the table can be out of date. See the latest spare parts of the CRB 15000 via myABB Business Portal, www.abb.com/myABB.

Spare part	Article number	Note
Joint unit	3HAC079141-001	Used for CRB 15000-5/0.95. New attachment screws and cable tie 3HAC075545-001 are included in the delivery.

Required tools and equipment

Equipment	Article number	Note
Lifting aid	3HAC077788-001	For joint units on axes 1, 2 and 3 of CRB 15000-5/0.95. Attachment screws M4x35 (4 pcs) are enclosed.
Guide pin, M4x120	3HAC077786-001	Always use guide pins in pairs. For joint units on axes 1, 2 and 3 of CRB 15000-5/0.95 and axis 3 of CRB 15000-10/1.52 and CRB 15000-12/1.27.
Protection plate	3HAC077790-001	For protection of drive board during cabling installation on joint units of CRB 15000-5/0.95.
Cable tie gun EVO 7i	-	HellermannTyton 110-77001 or similar
Standard toolkit	-	Content is defined in section Standard toolkit on page 1099 .

Required consumables

Consumable	Article number	Note
Cleaning agent	-	Isopropanol
Flange sealant	-	Loctite 574
Cable ties	-	
O-ring	3HAB3772-64	Base cover, used for CRB 15000-5/0.95.
O-ring	3HAC061327-047	Cover for axis 2/3, used for CRB 15000-5/0.95. Replace if damaged.
O-ring	3HAC061327-044	Lower arm, inner cover of CRB 15000-5/0.95. 1 pcs / cover. Replace if damaged.

Continues on next page

5 Repair



5.6.1 Replacing the axis-1 joint unit (CRB 15000-5/0.95)

Continued

Removing the joint unit

Use these procedures to remove the joint unit.

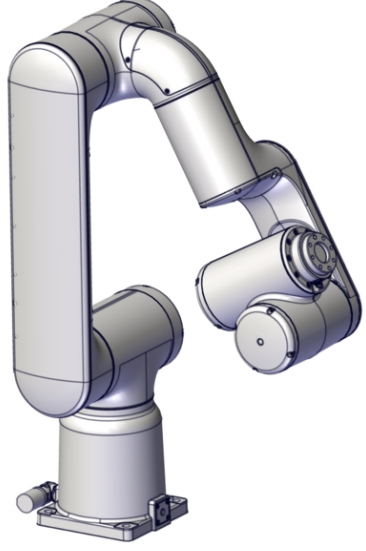
Preparations before removing the joint unit

	Action	Note
1	<p>Jog the robot to the specified position:</p> <ul style="list-style-type: none"> • Axis 1: 0° (home position) • Axis 2: 0° • Axis 3: +60° • Axis 4: 0° • Axis 5: -90° • Axis 6: No significance. <p> CAUTION</p> <p>Jog the axis on which the joint unit is to be replaced to home position, to achieve correct cable routing during replacement of the joint unit.</p>	 <p>xx2100000044</p>
2	<p> CAUTION</p> <p>Turn off all supplies for electrical power to the robot, before starting the repair work.</p>	

Removing the lower arm covers (-5/0.95)

	Action	Note
1	<p> CAUTION</p> <p>Make sure that all supplies for electrical power are turned off.</p>	

Continues on next page

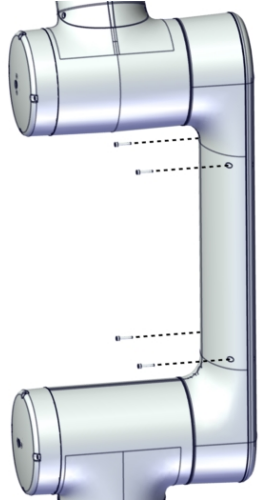
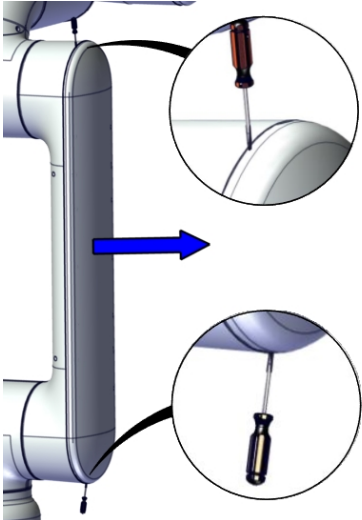
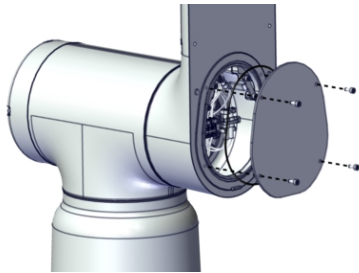
	Action	Note
2	Remove the four lower arm cover screws.	 <p>xx2000001929</p>
3	Remove the cover by inserting a small flat screwdriver to snap open the locks at each end of the cover.	 <p>xx2100000267</p>
4	Remove the inner cover by removing the four screws.	 <p>xx2000001930</p>

5 Repair

5.6.1 Replacing the axis-1 joint unit (CRB 15000-5/0.95)

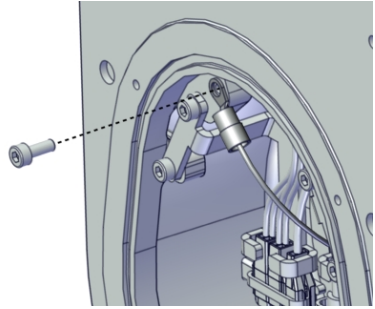
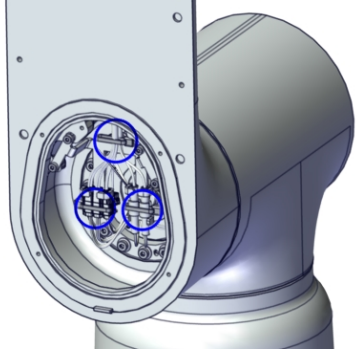
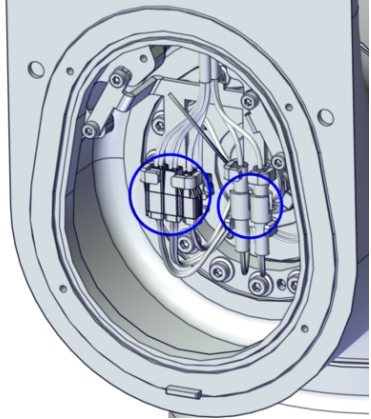

Continued

Disconnecting the cabling between the lower arm and the swing

	Action	Note
1	Remove the functional earth cable by removing the screw.	 xx2000001936
2	Cut the cable ties.	 xx2000001937
3	Snap loose and disconnect all connectors.	 xx2000001938

Continues on next page

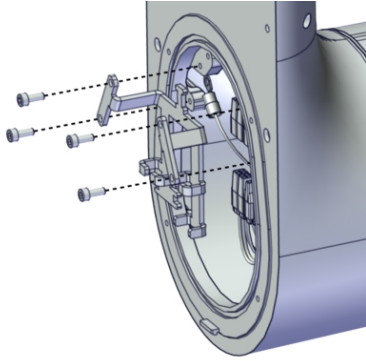
Removing the lower and upper arm assembled

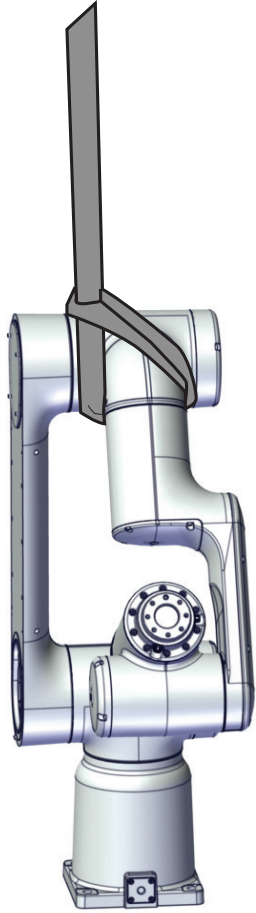

	Action	Note
1	Remove the cable bracket by removing the four screws.	 <p>xx200001939</p>
2	Secure the weight of the upper and lower arm.  CAUTION The weight of the complete upper and lower arm together is 18 kg	Suggestion with lifting sling and an overhead crane. Example of CRB 15000-5/0.95, similar to CRB 15000-10/1.52 and CRB 15000-12/1.27.  <p>xx210000294</p>

Continues on next page

5 Repair

5.6.1 Replacing the axis-1 joint unit (CRB 15000-5/0.95)

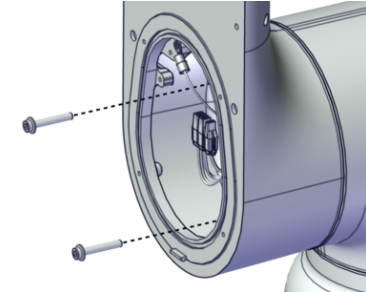
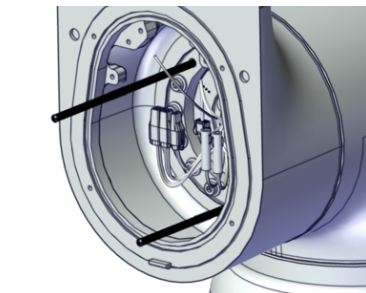
Continued

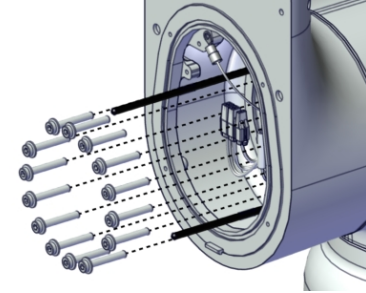
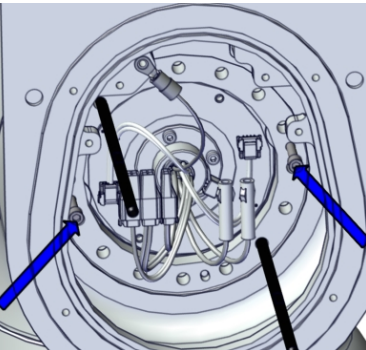
	Action	Note
3	<p>Remove two attachment screws and fit two guide pins to the axis-2 joint unit.</p> <p> CAUTION</p> <p>Do not mix the flange screws used for CRB 15000-5/0.95 and the threaded screws used for CRB 15000-10/1.52 and CRB 15000-12/1.27. Always use washers together with the threaded screws for CRB 15000-10/1.52 and CRB 15000-12/1.27. Illustration is for reference only.</p>	<p>Guide pin, M4x120: 3HAC077786-001</p> <p>Always use guide pins in pairs.</p>  <p>xx2000001951</p>  <p>xx2000001960</p>
4	<p>Remove the lower arm attachment screws.</p> <p> CAUTION</p> <p>Do not mix the flange screws used for CRB 15000-5/0.95 and the threaded screws used for CRB 15000-10/1.52 and CRB 15000-12/1.27. Always use washers together with the threaded screws for CRB 15000-10/1.52 and CRB 15000-12/1.27. Illustration is for reference only.</p>	 <p>xx2000001940</p>
5	<p>Use two fully threaded attachment screws as removal tools to press the lower arm out of position.</p>	 <p>xx2000002151</p>

Continues on next page

5.6.1 Replacing the axis-1 joint unit (CRB 15000-5/0.95)

Continued

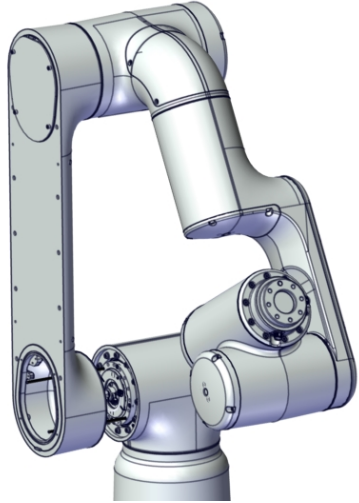
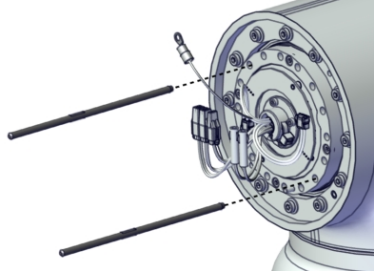
	Action	Note
6	Remove the complete arm system from the swing.	 <p>xx2000001941</p>
7	Remove the guide pins.	 <p>xx2000002432</p>

Removing the swing cover (-5/0.95)

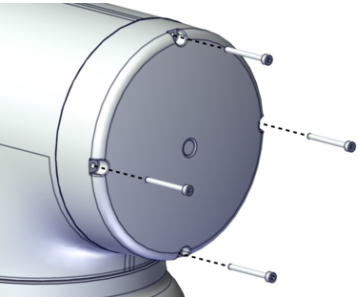
	Action	Note
1	 CAUTION Make sure that all supplies for electrical power are turned off.	
2	Remove the cover screws.	 <p>xx2000001935</p>

Continues on next page

5 Repair

5.6.1 Replacing the axis-1 joint unit (CRB 15000-5/0.95)

Continued

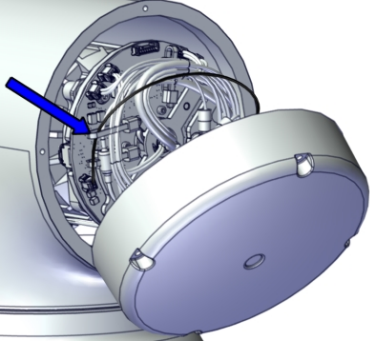
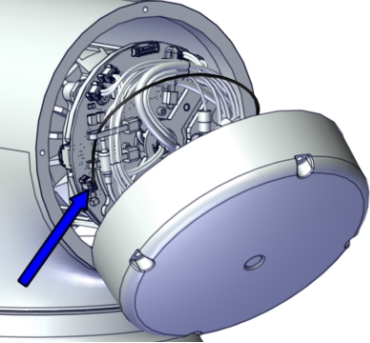
	Action	Note
3	<p> CAUTION</p> <p>Valid for CRB 15000-5/0.95</p> <p>There is cabling connected between the cover and the joint unit drive board.</p> <p>Open the cover with care to avoid damage to the cabling or the connector(s).</p> <p>Do not leave the cover in location without being secured with the attachment screws.</p>	
4	<p>For robots with RobotWare earlier than 7.10</p> <p>Open the cover and cut the cable tie that holds the brake release cable.</p>	 <p>xx2000001931</p>
5	<p>For robots with RobotWare earlier than 7.10</p> <p>Disconnect the brake release connector DR.X8 from the drive board.</p> <p>Remove the cover.</p>	 <p>xx2000001932</p>



Disconnecting the axis-2 joint unit cabling

	Action	Note
1	<p> ELECTROSTATIC DISCHARGE (ESD)</p> <p>The unit is sensitive to ESD. Before handling the unit read the safety information in section The unit is sensitive to ESD on page 53.</p>	

Continues on next page

5.6.1 Replacing the axis-1 joint unit (CRB 15000-5/0.95)

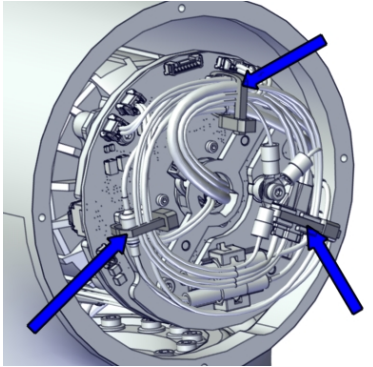
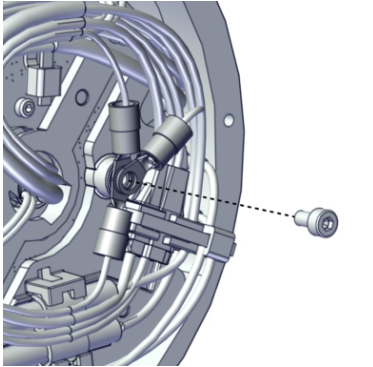
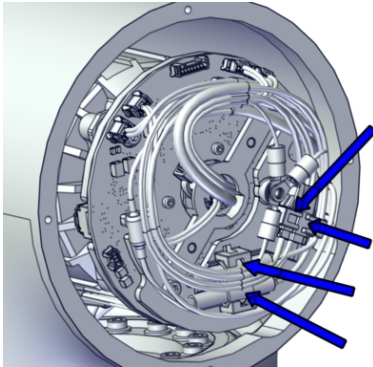
Continued

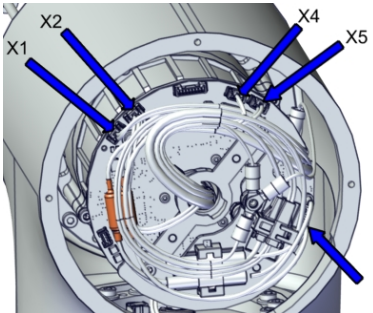
	Action	Note
2	Cut the cable ties.	 <p>xx2000001946</p>
3	Remove the functional and protective earth cables by removing the screw.	 <p>xx2000001945</p>
4	Snap loose and disconnect the connectors: <ul style="list-style-type: none"> • J2.DC+ • J2.DC- • J2.CS • J2.CP 	 <p>xx2000001944</p>
5	Disconnect the connectors from the drive board. <ul style="list-style-type: none"> • D2.X1 from X1 • D2.DC+ from DC+ • D2.DC- from ground • D2.X4 from X4 • D2.X2 from X2 • D2.X5 from X5 <p> CAUTION</p> <p>Use tweezers to unlock connectors and pull them off.</p>	 <p>xx2000002013</p>

Continues on next page

5 Repair

5.6.1 Replacing the axis-1 joint unit (CRB 15000-5/0.95)

Continued

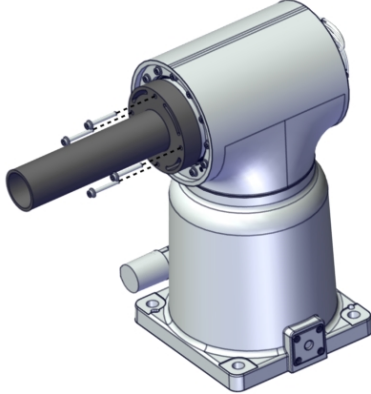
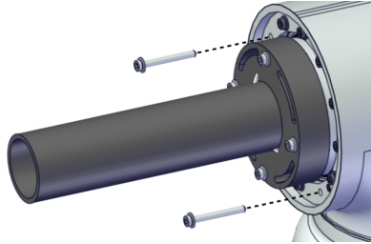
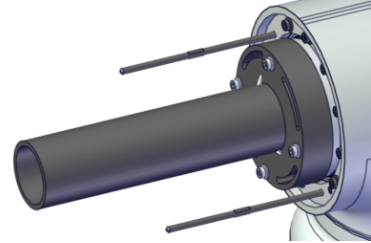
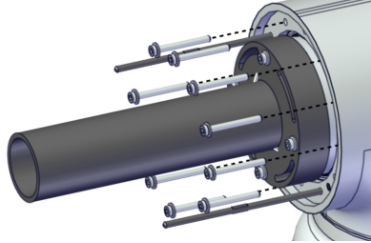

Removing the axis-2 joint unit (-5/0.95)

	Action	Note
1	<p>Fit the lifting aid to the joint unit, on the torque sensor side.</p> <p> CAUTION</p> <p>The connectors and the joint unit cables are sensitive to mechanical damage. Handle the assembly with care.</p>	<p>Lifting aid: 3HAC077788-001 Screws: M4x35 (4 pcs)</p>  <p>xx2000001956</p>
2	<p>Remove two attachment screws. Dispose the screws. New screws are included in the spare part delivery of the joint unit.</p>	 <p>xx2100000295</p>
3	<p>Fit two guide pins to the axis-2 joint unit.</p>	<p>Guide pin, M4x120: 3HAC077786-001 Always use guide pins in pairs. For joint units on axes 1, 2 and 3 of CRB 15000-5/0.95 and axis 3 of CRB 15000-10/1.52 and CRB 15000-12/1.27.</p>  <p>xx2000002433</p>
4	<p>Remove the remaining attachment screws. Use two screws as press out screws in the upcoming step, then dispose all screws. New screws are included in the spare part delivery of the joint unit.</p>	 <p>xx2000001943</p>

Continues on next page

5.6.1 Replacing the axis-1 joint unit (CRB 15000-5/0.95)

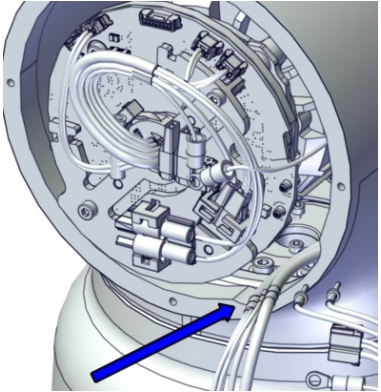
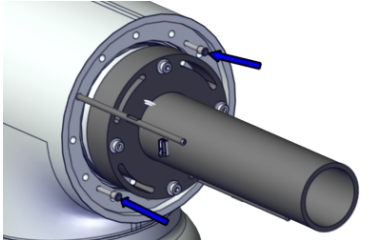
Continued

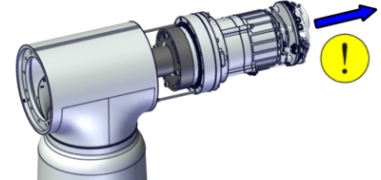
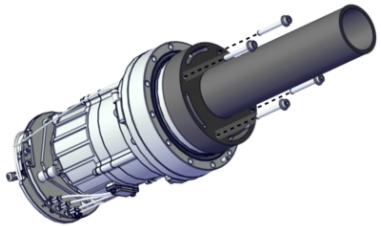
	Action	Note
5	Put the cabling at the slot in order not to squeeze it during removal of joint unit.	 <p>xx2100000045</p>
6	Press the joint unit out of position using two of the previous attachment screws as removal tools.	 <p>xx2000002434</p>
7	<p>Remove the joint unit from the swing.</p> <p> CAUTION</p> <p>The connectors and the joint unit cables are sensitive to mechanical damage. Handle the assembly with care.</p>	 <p>xx2000001958</p>
8	Remove the lifting aid and guide pins.	 <p>xx2000001957</p>





Continues on next page

5 Repair

5.6.1 Replacing the axis-1 joint unit (CRB 15000-5/0.95)

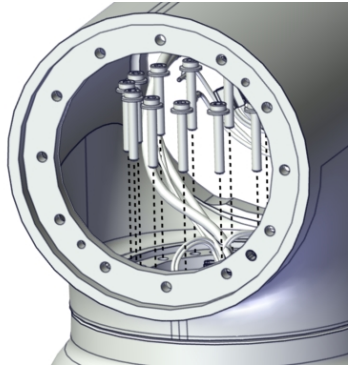
Continued

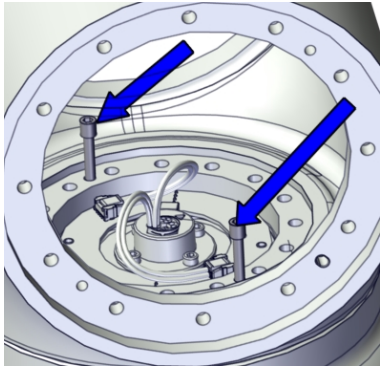
Removing the swing (-5/0.95)

	Action	Note
1	<p>Remove the swing attachment screws.</p> <p> CAUTION</p> <p>Do not mix the flange screws used for CRB 15000-5/0.95 and the threaded screws used for CRB 15000-10/1.52 and CRB 15000-12/1.27. Always use washers together with the threaded screws for CRB 15000-10/1.52 and CRB 15000-12/1.27. Illustration is for reference only.</p>	 <p>xx2000001987</p>
2	<p>Use two fully threaded attachment screws as removal tools to press the swing out of position.</p> <p> CAUTION</p> <p>Do not mix the flange screws used for CRB 15000-5/0.95 and the threaded screws used for CRB 15000-10/1.52 and CRB 15000-12/1.27. Always use washers together with the threaded screws for CRB 15000-10/1.52 and CRB 15000-12/1.27. Illustration is for reference only.</p>	 <p>xx2000002152</p>
3	<p>Lift away the swing.</p> <p> CAUTION</p> <p>The torque sensor (on the exposed PCBA) is sensitive to mechanical damage. Handle the assembly with care.</p>	

Loosening the base and removing the base cover

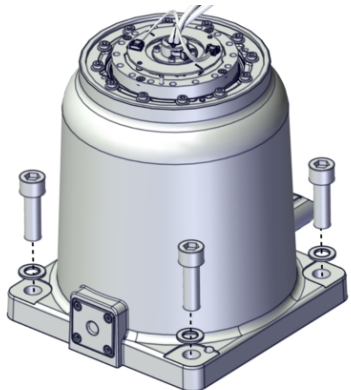
	Action	Note
1	<p>Loosen the base from the foundation by removing the attachment screws and washers.</p>	 <p>xx2000002006</p>

Continues on next page

5.6.1 Replacing the axis-1 joint unit (CRB 15000-5/0.95)

Continued

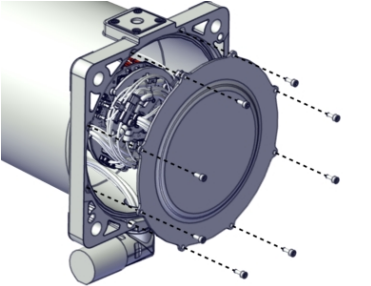
	Action	Note
2	Tilt the base on to its side and remove the bottom cover by removing the attachment screws.	 <p>xx2000002007</p>

Disconnecting the axis-1 joint unit cabling

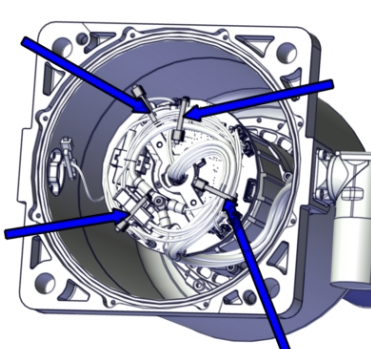
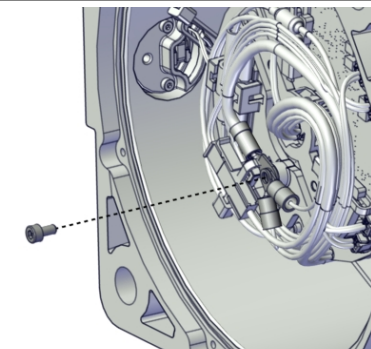
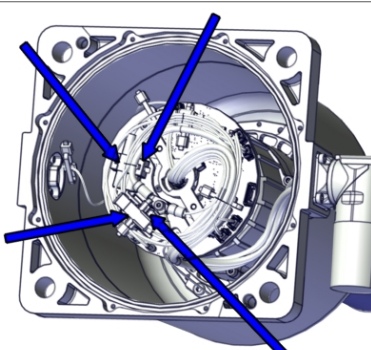
	Action	Note
1	Cut the cable ties.	 <p>xx2000002012</p>
2	Remove the functional and protective earth cables by removing the screw.	 <p>xx2000002011</p>
3	Snap loose and disconnect the connectors: <ul style="list-style-type: none"> • J1.DC+ • J1.DC- • J1.CS • J1.CP 	 <p>xx2000002010</p>

Continues on next page

5 Repair

5.6.1 Replacing the axis-1 joint unit (CRB 15000-5/0.95)

Continued

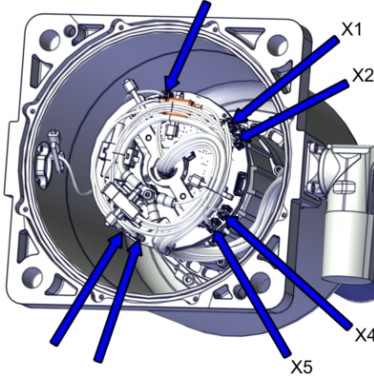
	Action	Note
4	<p>Disconnect the connectors from the drive board.</p> <ul style="list-style-type: none"> • D1.X1 from X1 • D1.DC+ from DC+ • D1.DC- from ground • D1.X4 from X4 • D1.X2 from X2 • D1.X5 from X5 • DR.X8 from X8 <p> CAUTION</p> <p>Use tweezers to unlock connectors and pull them off.</p>	 <p>xx2000002009</p>

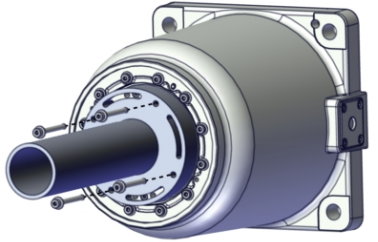
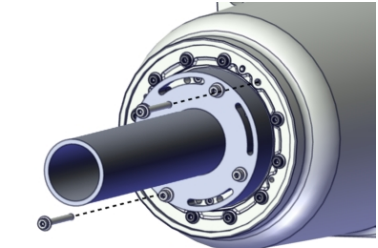

Removing the axis-1 joint unit (-5/0.95)

	Action	Note
1	<p>Fit the lifting aid to the joint unit.</p> <p> CAUTION</p> <p>The connectors and the joint unit cables are sensitive to mechanical damage. Handle the assembly with care.</p>	<p>Lifting aid: 3HAC077788-001 Screws: M4x35 (4 pcs)</p>  <p>xx2000001994</p>
2	<p>Remove two attachment screws. Dispose the screws. New screws are included in the spare part delivery of the joint unit.</p>	 <p>xx2100000296</p>

Continues on next page

5.6.1 Replacing the axis-1 joint unit (CRB 15000-5/0.95)

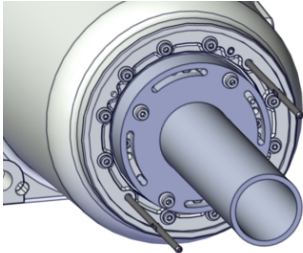
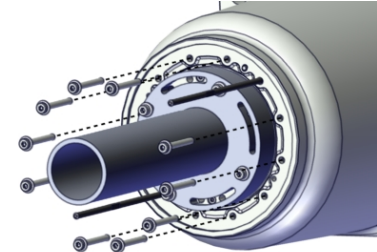
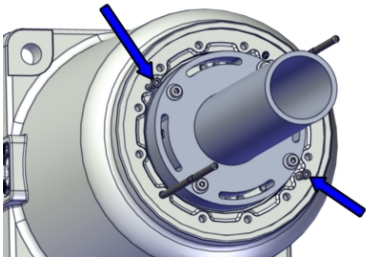
Continued

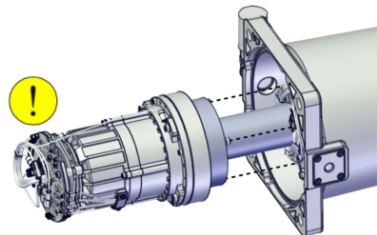
	Action	Note
3	Fit two guide pins to the axis-1 joint unit.	<p>Guide pin, M4x120: 3HAC077786-001</p> <p>Always use guide pins in pairs.</p> <p>For joint units on axes 1, 2 and 3 of CRB 15000-5/0.95 and axis 3 of CRB 15000-10/1.52 and CRB 15000-12/1.27.</p>  <p>xx2000002435</p>
4	<p>Remove the remaining attachment screws.</p> <p>Use two screws as press out screws in the upcoming step, then dispose all screws.</p> <p>New screws are included in the spare part delivery of the joint unit.</p>	 <p>xx2000002008</p>
5	Press the joint unit out of position using two of the previous attachment screws as removal tools.	 <p>xx2000002436</p>
6	<p>Remove the joint unit from the base.</p> <p> CAUTION</p> <p>The connectors and the joint unit cables are sensitive to mechanical damage. Handle the assembly with care.</p>	 <p>xx2000002014</p>

Continues on next page



5 Repair

5.6.1 Replacing the axis-1 joint unit (CRB 15000-5/0.95)

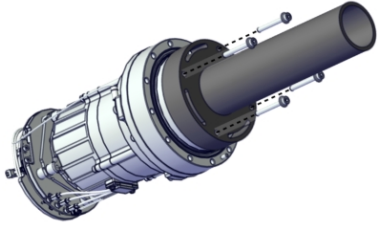
Continued

	Action	Note
7	Remove the lifting aid and guide pins.	 xx200001957

Removing the joint cable

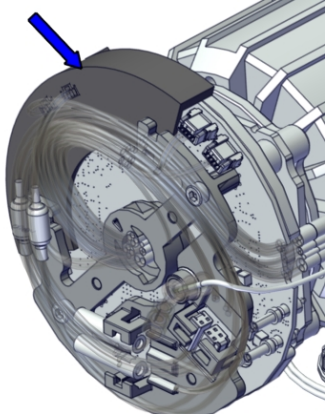
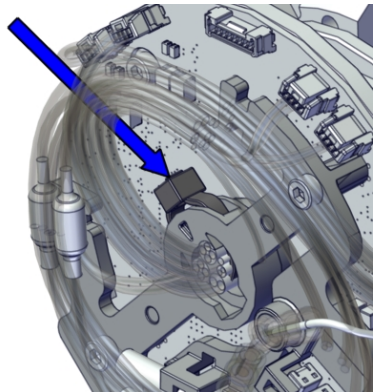
	Action	Note
1	 ELECTROSTATIC DISCHARGE (ESD) The unit is sensitive to ESD. Before handling the unit read the safety information in section The unit is sensitive to ESD on page 53 .	
2	Fit the protection plate to the drive board unit.  Tip Using the protection plate is important for protecting the drive board unit. If complete joint unit is to be replaced, the protection plate is not needed.	Protection plate: 3HAC077790-001 (for CRB 15000-5/0.95) / 3HAC087789-001 (for CRB 15000-10/1.52 and CRB 15000-12/1.27)  xx200002057
3	Cut the cable tie at the drive board.	 xx200002058

Continues on next page

5.6.1 Replacing the axis-1 joint unit (CRB 15000-5/0.95)

Continued

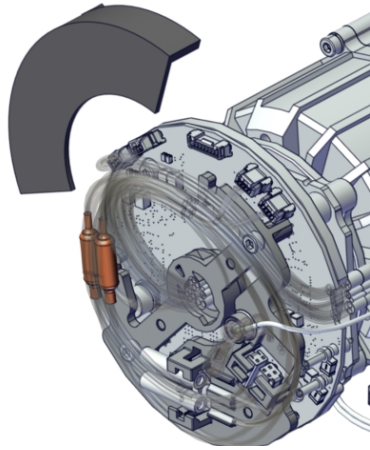
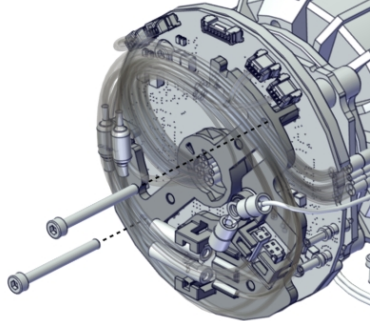
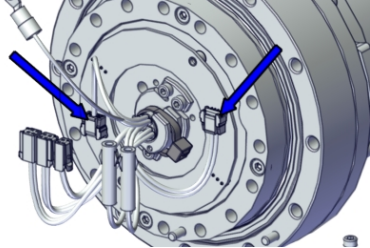
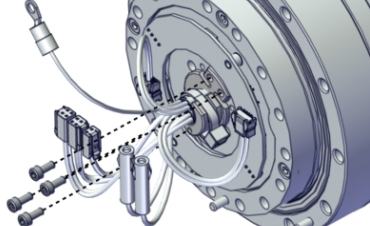
	Action	Note
4	Remove the protection plate.	 <p>xx2100000301</p>
5	Remove the cable support from the drive board by removing the attachment screws.	 <p>xx2000002055</p>
6	Disconnect the two connectors from the torque sensor board. <ul style="list-style-type: none"> • TQ.A • TQ.B 	 <p>xx2000002053</p>
7	Remove the cable plate by removing the attachment screws.	 <p>xx2000002049</p>

Continues on next page

5 Repair

5.6.1 Replacing the axis-1 joint unit (CRB 15000-5/0.95)

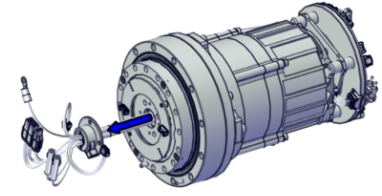

Continued

	Action	Note
8	<p>Remove the joint cable from the hollow shaft from the torque sensor side.</p> <p> CAUTION</p> <p>The connectors and the joint unit cables are sensitive to mechanical damage. Handle the assembly with care.</p>	 <p>xx2000002060</p>

Refitting the joint unit

Use these procedures to refit the joint unit.

Refitting the joint cable

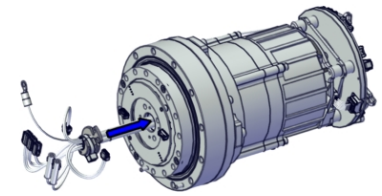
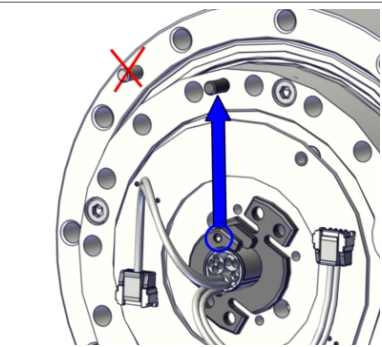
	Action	Note
1	<p> ELECTROSTATIC DISCHARGE (ESD)</p> <p>The unit is sensitive to ESD. Before handling the unit read the safety information in section The unit is sensitive to ESD on page 53.</p>	
2	<p>Place the joint cable through the hollow shaft from the torque sensor side.</p> <p> CAUTION</p> <p>The connectors and the joint unit cables are sensitive to mechanical damage. Handle the assembly with care.</p>	 <p>xx2000002048</p>
3	<p>Orient the cable plate according to the figure. The circle on the cable plate should point towards the guide pin on the torque sensor.</p>	 <p>xx2000002051</p>

Continues on next page

5.6.1 Replacing the axis-1 joint unit (CRB 15000-5/0.95)

Continued

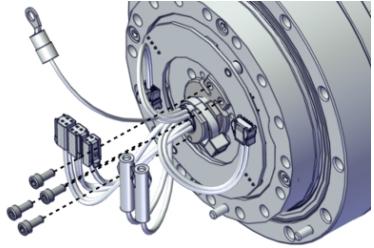
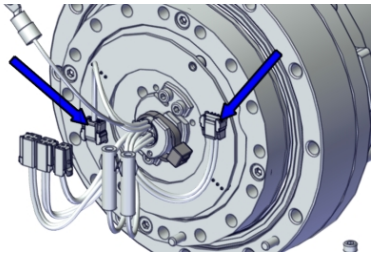
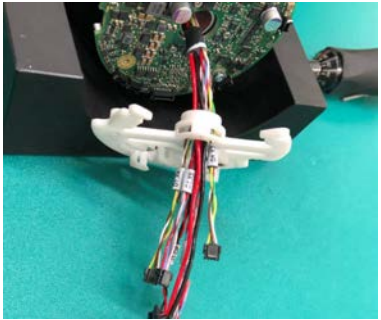
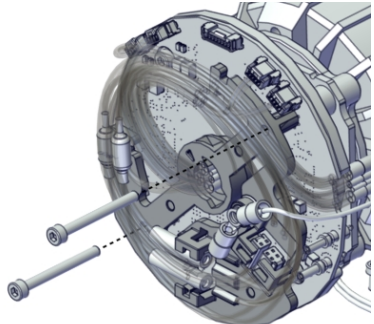
	Action	Note
4	Secure the cable plate to the joint unit with the attachment screws.	<p>Hex socket head cap screw: M2.5x6 12.9 Lafre 2C2B/FC6.9 (4 pcs) Tightening torque: 0.45 Nm.</p>  <p>xx2000002049</p>
5	<p>Connect the two connectors to the torque sensor board.</p> <ul style="list-style-type: none"> • TQ.A to CH1/A • TQ.B to CH2/B 	 <p>xx2000002053</p>
6	Insert the cabling through the cable support and fit the support to the drive board with the attachment screws.	 <p>xx2000002056</p> <p>Hex socket head cap screw: M3x30 12.9 Lafre 2C2B/FC6.9 (2 pcs) Tightening torque: 0.45 Nm.</p>  <p>xx2000002055</p>

Continues on next page

5 Repair

5.6.1 Replacing the axis-1 joint unit (CRB 15000-5/0.95)

Continued

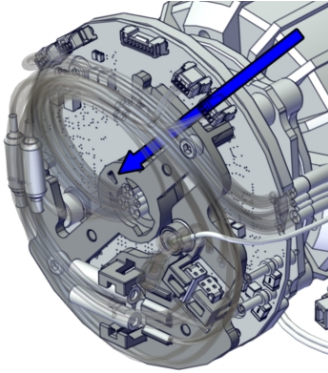
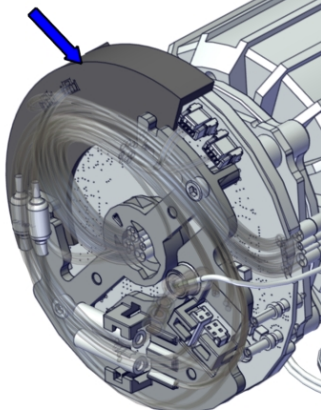
	Action	Note
7	Keep the cabling loose, making sure not to twist or strain it. Use the cable tie to pre-fix the cable by hand.	 xx2100000507
8	Fit the protection plate to the drive board unit.	Protection plate: 3HAC077790-001 (for CRB 15000-5/0.95) / 3HAC087789-001 (for CRB 15000-10/1.52 and CRB 15000-12/1.27)  xx2000002057

Continues on next page

5.6.1 Replacing the axis-1 joint unit (CRB 15000-5/0.95)

Continued

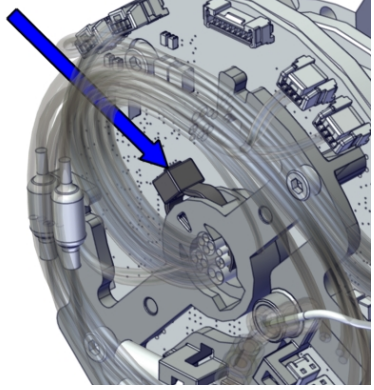
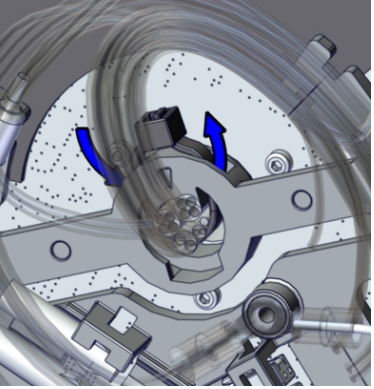
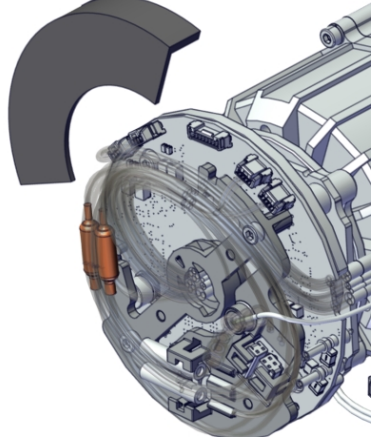
	Action	Note
9	<p>Secure the cables to the cable support with a cable tie, using a cable tie gun.</p> <p>Assembly direction for the cable tie is shown in the figure.</p>	<p>Cable tie: 3HAC075545-001. For securing joint unit cable.</p> <p>Cable tie gun EVO 7i</p> <p>Setting for cable tie gun: 6.75.</p>  <p>xx2000002058</p>  <p>xx2000002059</p>
10	<p>Remove the protection plate.</p>	 <p>xx2100000301</p>



Continues on next page

5 Repair



5.6.1 Replacing the axis-1 joint unit (CRB 15000-5/0.95)

Continued

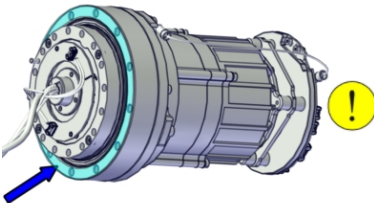
Preparations before fitting the joint unit (-5/0.95)

	Action	Note
1	 ELECTROSTATIC DISCHARGE (ESD) The unit is sensitive to ESD. Before handling the unit read the safety information in section The unit is sensitive to ESD on page 53 .	
2	Clean the mounting surface of the joint unit and the mating surface on the casting with isopropanol. Joint unit mounting surface is pointed out in the figure.	Cleaning agent: Isopropanol Flange sealant: Loctite 574
3	Apply a thin layer of flange sealant to the mounting surface. Do not contaminate the radial sealing with sealant.  CAUTION The connectors and the joint unit cables are sensitive to mechanical damage. Handle the assembly with care.  ELECTROSTATIC DISCHARGE (ESD) The unit is sensitive to ESD. Before handling the unit read the safety information in section The unit is sensitive to ESD on page 53 .	 xx2000001860



Refitting the axis-1 joint unit (-5/0.95)

	Action	Note
1	 ELECTROSTATIC DISCHARGE (ESD) The unit is sensitive to ESD. Before handling the unit read the safety information in section The unit is sensitive to ESD on page 53 .	
2	Fit the lifting aid to the joint unit.  CAUTION The connectors and the joint unit cables are sensitive to mechanical damage. Handle the assembly with care.	Joint unit: 3HAC079141-001 Lifting aid: 3HAC077788-001 Screws: M4x35 (4 pcs)

Continues on next page

5.6.1 Replacing the axis-1 joint unit (CRB 15000-5/0.95)

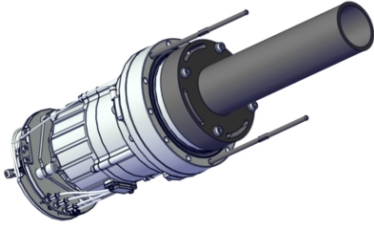
Continued

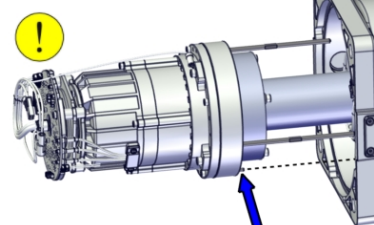
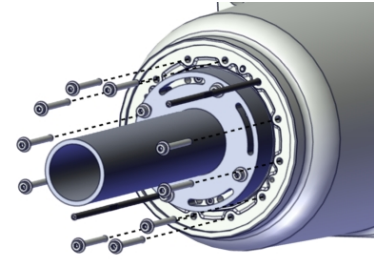
	Action	Note
3	Fit two guide pins to the joint unit.	<p>Guide pin, M4x120: 3HAC077786-001</p> <p>Always use guide pins in pairs.</p> <p>For joint units on axes 1, 2 and 3 of CRB 15000-5/0.95 and axis 3 of CRB 15000-10/1.52 and CRB 15000-12/1.27.</p>  <p>xx2000002438</p>
4	<p>Fit the joint unit to the base, aligning the pin with the pin hole.</p> <p> CAUTION</p> <p>The connectors and the joint unit cables are sensitive to mechanical damage. Handle the assembly with care.</p>	 <p>xx2000002015</p>
5	Secure the joint unit with new attachment screws.	<p>Flange socket head screw with glue: 3HAB3413-435</p> <p>M4x35 12.9 Lafre 2C2B/FC6.9+PrO-COat111, with NYPLAS glue , 12 pcs</p> <p>Used for joint unit of CRB 15000-5/0.95.</p> <p>Always use new screws when refitting a joint unit. If ordering a new joint unit spare part, new screws are included.</p>  <p>xx2000002008</p>

Continues on next page

5 Repair

5.6.1 Replacing the axis-1 joint unit (CRB 15000-5/0.95)

Continued

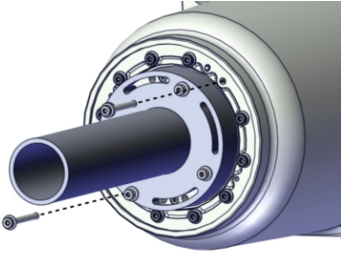
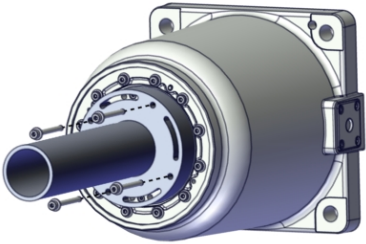
	Action	Note
6	Remove the guide pins and secure the remaining two attachment screws.	 xx2100000296
7	Pre-tighten the screws crosswise.	
8	Torque tighten all screws crosswise.	Tightening torque: 4.3 Nm.
9	Remove the lifting aid by removing the screws.	 xx2000001994
10	Clean pushed-out flange sealant, if any.	

Connecting the axis-1 joint unit cabling

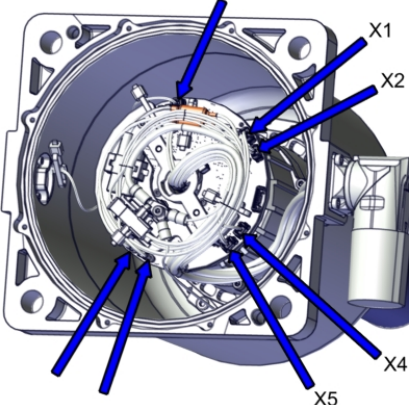
	Action	Note
1	 ELECTROSTATIC DISCHARGE (ESD) The unit is sensitive to ESD. Before handling the unit read the safety information in section The unit is sensitive to ESD on page 53 .	
2	Reconnect the connectors to the drive board. <ul style="list-style-type: none"> • D1.X1 to X1 • D1.DC+ to DC+ • D1.DC- to Ground • D1.X4 to X4 • D1.X2 to X2 • D1.X5 to X5 • DR.X8 to X8 	 xx2000002009

Continues on next page

5.6.1 Replacing the axis-1 joint unit (CRB 15000-5/0.95)

Continued

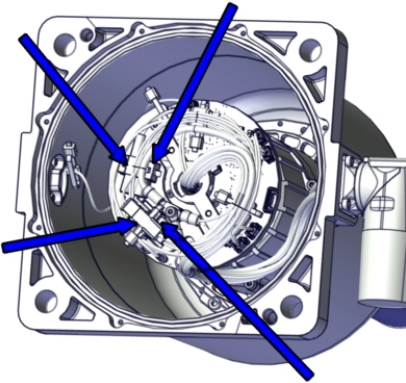
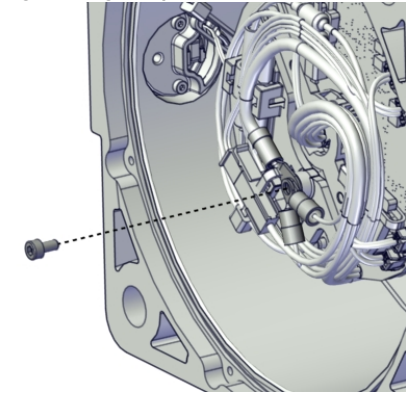
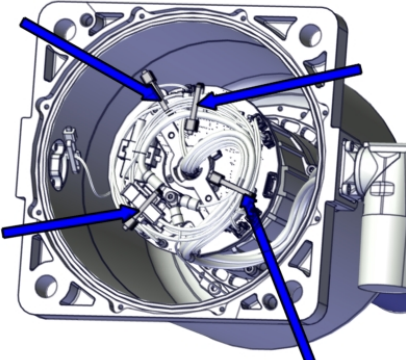
	Action	Note
3	<p>Connect the connectors to each other and snap them to the cable holders.</p> <ul style="list-style-type: none"> • J1.DC+ to J1.DC+ • J1.DC- to J1.DC- • J1.CS to J1.CS • J1.CP to J1.CP 	 <p>xx2000002010</p>
4	<p>Secure the cables for functional earth and protective earth with a screw.</p>	<p>Hex socket head cap screw: M3x6 (1 pcs). Tightening torque: 0.8 Nm.</p>  <p>xx2000002011</p>
5	<p>Secure the cabling with cable ties.</p>	<p>Cable ties (4 pcs)</p>  <p>xx2000002012</p>



Continues on next page

5 Repair

5.6.1 Replacing the axis-1 joint unit (CRB 15000-5/0.95)

Continued

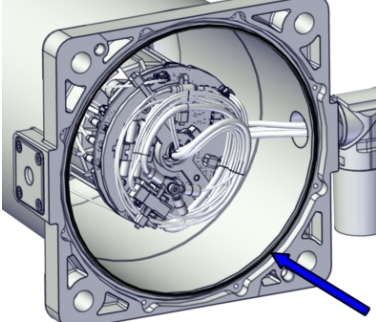
Refitting the base cover (-5/0.95)

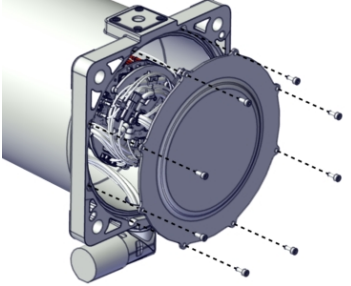
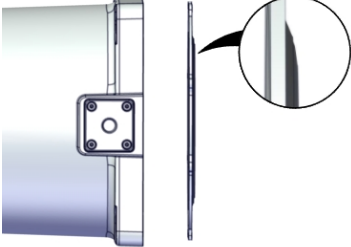
	Action	Note
1	<p>Wipe, lubricate and fit the o-ring to its groove. Replace if damaged.</p>	<p>O-ring: 3HAB3772-64 Grease: 3HAC042536-001 (Shell Gadus S2)</p>  <p>xx2000002016</p>
2	<p>Refit the bottom cover with the attachment screws.</p> <p> Note</p> <p>For CRB 15000-5/0.95, fit the cover in correct direction, the protrusion of the cover must face outwards.</p>	<p>Hex socket head cap screw: M3x8 12.9 Lafre 2C2B/FC6.9 (8 pcs) Tightening torque: 1.2 Nm.</p>  <p>xx2000002007</p>  <p>xx2100000268</p>

Continues on next page

5.6.1 Replacing the axis-1 joint unit (CRB 15000-5/0.95)

Continued

Securing the base

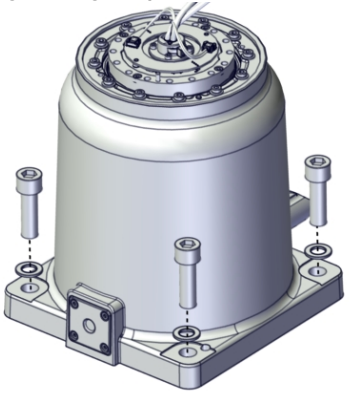
	Action	Note
1	Lift the base to standing and secure it to the foundation with the attachment screws and washers.	<p>Attachment screws: M10x35 8.8 (4 pcs). Washers: 23/10.5/2.5 mm Steel (4 pcs). Tightening torque: 32 Nm ±10%.</p>  <p>xx2000002006</p>

Refitting the swing(-5/0.95)

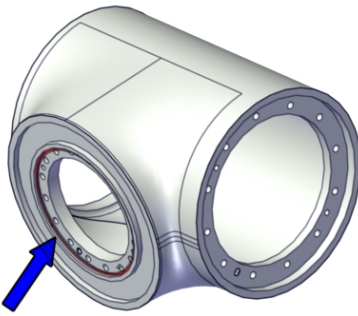

	Action	Note
1	Clean the mounting surface with isopropanol. Apply flange sealant to the corner of the base mounting surface, as pointed out in the figure.	<p>Cleaning agent: Isopropanol Flange sealant: Loctite 574</p>  <p>xx2000001990</p>
2	Separate the new swing parts by removing the pre-assembling screws.	

Continues on next page

5 Repair

5.6.1 Replacing the axis-1 joint unit (CRB 15000-5/0.95)

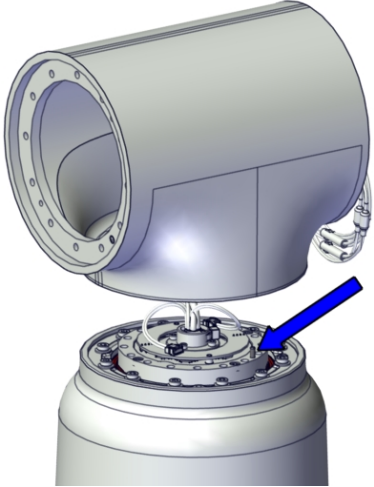
Continued

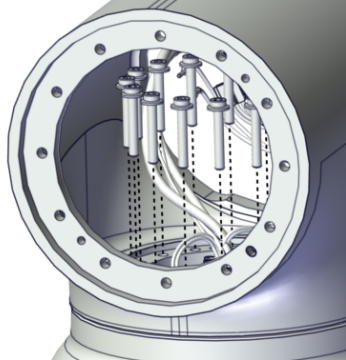
	Action	Note
3	<p>Refit the swing to the base unit, aligning the pin with the pin hole.</p> <p> CAUTION</p> <p>The torque sensor (on the exposed PCBA) is sensitive to mechanical damage. Handle the assembly with care.</p>	 <p>xx2000001989</p>
4	<p>Secure the swing with the attachment screws. Pre-tighten the screws crosswise firstly.</p> <p> CAUTION</p> <p>Do not mix the flange screws used for CRB 15000-5/0.95 and the threaded screws used for CRB 15000-10/1.52 and CRB 15000-12/1.27. Always use washers together with the threaded screws for CRB 15000-10/1.52 and CRB 15000-12/1.27. Illustration is for reference only.</p>	<p>Hex socket head cap flange screw: M4x25 12.9 Lafre 2C2B/FC6.9+PrO-COat111 (16 pcs)</p>  <p>xx2000001987</p>
5	Torque tighten all screws crosswise.	Tightening torque: 4.6 Nm



Preparations before fitting the joint unit

	Action	Note
1	<p> ELECTROSTATIC DISCHARGE (ESD)</p> <p>The unit is sensitive to ESD. Before handling the unit read the safety information in section The unit is sensitive to ESD on page 53.</p>	



Continues on next page

5.6.1 Replacing the axis-1 joint unit (CRB 15000-5/0.95)

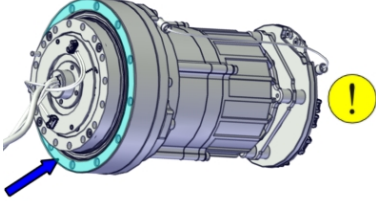
Continued

	Action	Note
2	Clean the mounting surface of the joint unit and the mating surface on the casting with isopropanol. Joint unit mounting surface is pointed out in the figure.	Cleaning agent: Isopropanol Flange sealant: Loctite 574
3	Apply a thin layer of flange sealant to the mounting surface. Do not contaminate the radial sealing with sealant.  CAUTION The connectors and the joint unit cables are sensitive to mechanical damage. Handle the assembly with care.  ELECTROSTATIC DISCHARGE (ESD) The unit is sensitive to ESD. Before handling the unit read the safety information in section The unit is sensitive to ESD on page 53 .	 xx2000001860

Refitting the axis-2 joint unit (-5/0.95)

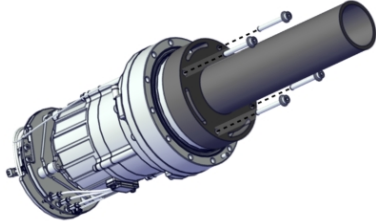





	Action	Note
1	 ELECTROSTATIC DISCHARGE (ESD) The unit is sensitive to ESD. Before handling the unit read the safety information in section The unit is sensitive to ESD on page 53 .	
2	Fit the lifting aid to the joint unit.  CAUTION The connectors and the joint unit cables are sensitive to mechanical damage. Handle the assembly with care.	Joint unit: 3HAC079141-001 Lifting aid: 3HAC077788-001 Screws: M4x35 (4 pcs)  xx2000001957

Continues on next page

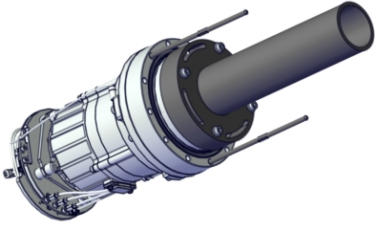
5 Repair

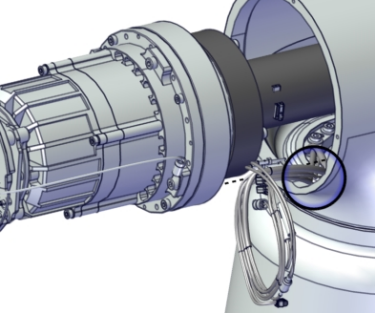
5.6.1 Replacing the axis-1 joint unit (CRB 15000-5/0.95)

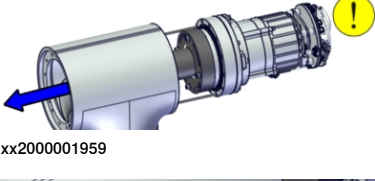
Continued

	Action	Note
3	Fit two guide pins to the joint unit.	<p>Guide pin, M4x120: 3HAC077786-001</p> <p>Always use guide pins in pairs.</p> <p>For joint units on axes 1, 2 and 3 of CRB 15000-5/0.95 and axis 3 of CRB 15000-10/1.52 and CRB 15000-12/1.27.</p>  <p>xx2000002438</p>
4	<p>Place the axis-1 cabling at the notch in the swing.</p> <p> CAUTION</p> <p>The cabling is sensitive to mechanical damage. Handle it with care to avoid damage to the cabling or the connector, avoid any kind of tilt or skew.</p>	 <p>xx2000002153</p>
5	<p>Fit the joint unit to the swing, aligning the pin with the pin hole.</p> <p> CAUTION</p> <p>The connectors and the joint unit cables are sensitive to mechanical damage. Handle the assembly with care.</p>	 <p>xx2000001959</p>  <p>xx2000001961</p>

Continues on next page

5.6.1 Replacing the axis-1 joint unit (CRB 15000-5/0.95)

Continued

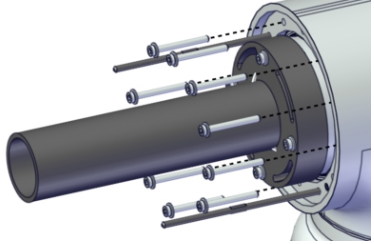
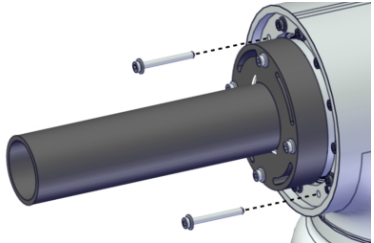
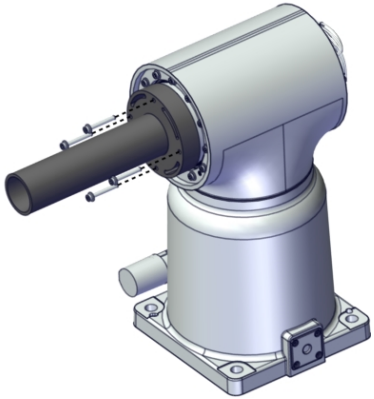
	Action	Note
6	Secure the joint unit with new attachment screws.	<p>Flange socket head screw with glue: 3HAB3413-435 M4x35 12.9 Lafre 2C2B/FC6.9+PrO-COat111, with NYPLAS glue , 12 pcs Used for joint unit of CRB 15000-5/0.95.</p> <p>Always use new screws when refitting a joint unit. If ordering a new joint unit spare part, new screws are included.</p>  <p>xx2000001943</p>
7	Remove the guide pins and secure the remaining two attachment screws.	 <p>xx2100000295</p>
8	Pre-tighten the screws crosswise.	
9	Torque tighten all screws crosswise.	Tightening torque: 4.3 Nm.
10	Remove the lifting aid by removing the screws.	 <p>xx2000001956</p>
11	Clean pushed-out flange sealant, if any.	



Continues on next page

5 Repair

5.6.1 Replacing the axis-1 joint unit (CRB 15000-5/0.95)

Continued

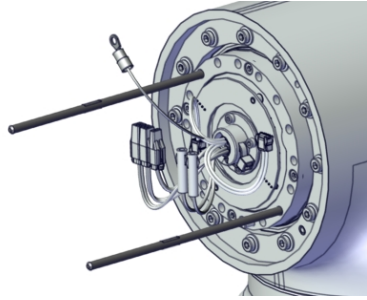
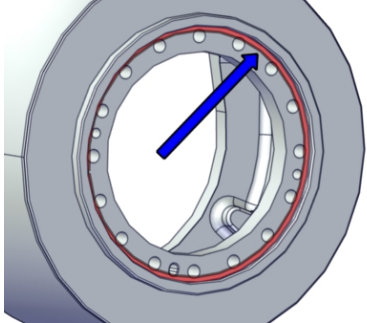
Refitting the lower and upper arm assembled (-5/0.95)

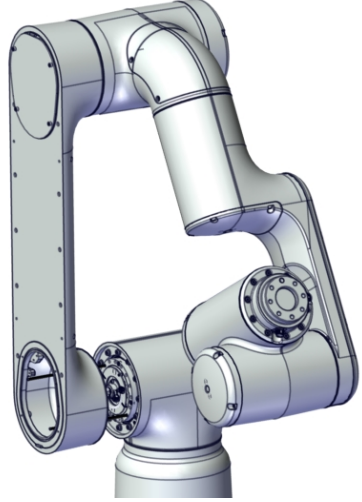
	Action	Note
1	Fit two guide pins to the axis-2 joint unit.	<p>Guide pin, M4x120: 3HAC077786-001</p>  <p>xx2000001949</p>
2	<p>Remove any old residuals of flange sealant from the lower arm mounting surface and clean with isopropanol.</p> <p>Apply new flange sealant to the corner of the lower arm mounting surface, as pointed out in the figure.</p>	<p>Cleaning agent: Isopropanol Flange sealant: Loctite 574</p>  <p>xx2000001963</p>
3	<p> CAUTION</p> <p>The weight of the complete upper and lower arm together is 18 kg</p>	
4	Lift the upper and lower arm assembly to mounting position and slide it onto the guide pins.	 <p>xx2000001941</p>

Continues on next page

5.6.1 Replacing the axis-1 joint unit (CRB 15000-5/0.95)

Continued

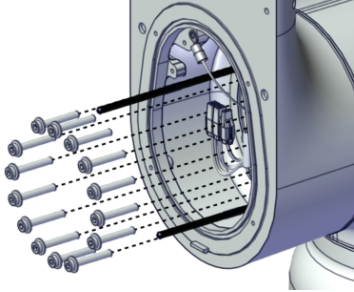
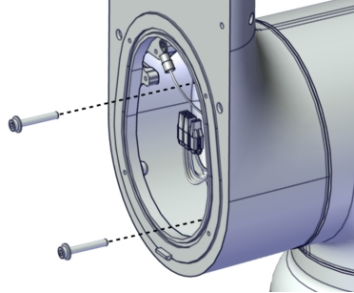
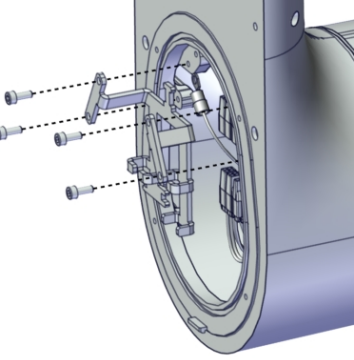
	Action	Note
5	<p>Secure the lower arm to the swing with all attachment screws but two. Pre-tighten the screws crosswise firstly.</p> <p>! CAUTION</p> <p>Do not mix the flange screws used for CRB 15000-5/0.95 and the threaded screws used for CRB 15000-10/1.52 and CRB 15000-12/1.27. Always use washers together with the threaded screws for CRB 15000-10/1.52 and CRB 15000-12/1.27. Illustration is for reference only.</p>	<p>Hex socket head cap flange screw: M4x25 12.9 Lafre 2C2B/FC6.9+PrO-COat111 (16 pcs)</p>  <p>xx2000001940</p>
6	<p>Remove the guide pins and fasten the remaining two screws.</p> <p>! CAUTION</p> <p>Do not mix the flange screws used for CRB 15000-5/0.95 and the threaded screws used for CRB 15000-10/1.52 and CRB 15000-12/1.27. Always use washers together with the threaded screws for CRB 15000-10/1.52 and CRB 15000-12/1.27. Illustration is for reference only.</p>	<p>Hex socket head cap flange screw: M4x25 12.9 Lafre 2C2B/FC6.9+PrO-COat111 (16 pcs)</p>  <p>xx2000001951</p>
7	<p>Torque tighten all screws crosswise.</p>	<p>Tightening torque: 4.6 Nm</p>
8	<p>Refit the cable bracket with four screws.</p>	<p>Hex socket head cap screw: M3x8 12.9 Lafre 2C2B/FC6.9 (4 pcs). Tightening torque: 0.8 Nm</p>  <p>xx2000001939</p>

Continues on next page

5 Repair

5.6.1 Replacing the axis-1 joint unit (CRB 15000-5/0.95)

Continued

Connecting the axis-2 joint unit cabling

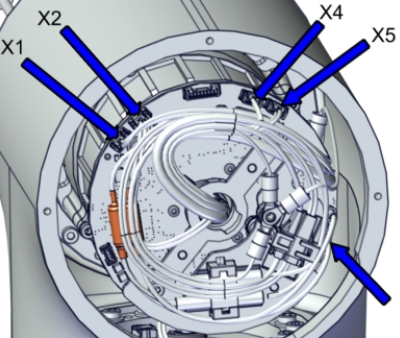
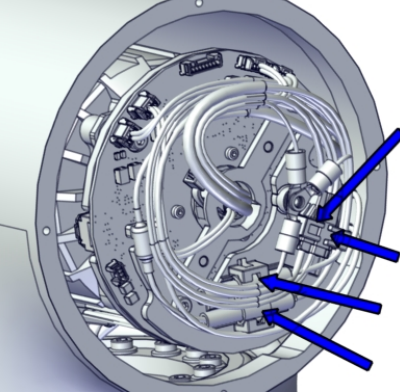
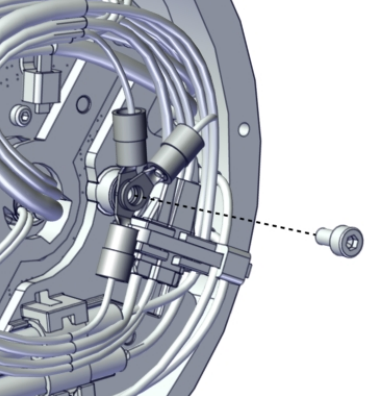
	Action	Note
1	 <p>ELECTROSTATIC DISCHARGE (ESD)</p> <p>The unit is sensitive to ESD. Before handling the unit read the safety information in section <i>The unit is sensitive to ESD on page 53.</i></p>	
2	<p>Reconnect the connectors to the drive board.</p> <ul style="list-style-type: none"> • D2.X1 to X1 • D2.DC+ to DC+ • D2.DC- to Ground • D2.X4 to X4 • D2.X2 to X2 • D2.X5 to X5 	 <p>xx2000002013</p>
3	<p>Connect the connectors to each other and snap them to the cable holders.</p> <ul style="list-style-type: none"> • J2.DC+ to J2.DC+ • J2.DC- to J2.DC- • J2.CS to J2.CS • J2.CP to J2.CP 	 <p>xx2000001944</p>
4	<p>Secure the cables for functional earth and protective earth with a screw.</p>	<p>Hex socket head cap screw: M3x6 (1 pcs).</p> <p>Tightening torque: 0.8 Nm.</p>  <p>xx2000001945</p>

Continues on next page

5.6.1 Replacing the axis-1 joint unit (CRB 15000-5/0.95)

Continued

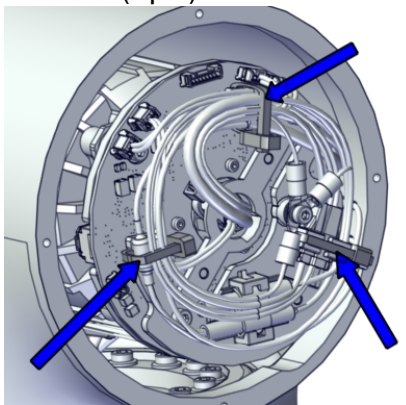
	Action	Note
5	Secure the cabling with cable ties.	Cable ties (3 pcs)  xx2000001946

Connecting the cabling between the lower arm and swing

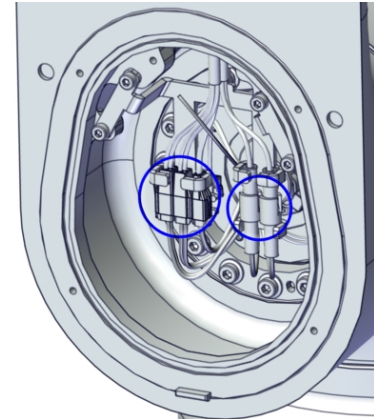
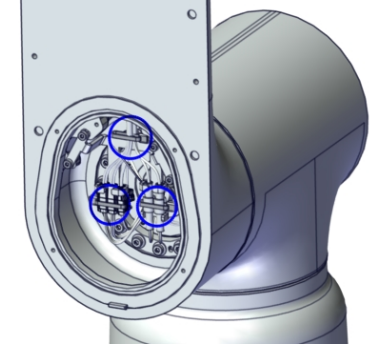
	Action	Note
1	Connect the connectors to each other and snap them to the cable holders.	 xx2000001938
2	Secure the cabling with cable ties.	Cable ties (3 pcs)  xx2000001937

Continues on next page

5 Repair

5.6.1 Replacing the axis-1 joint unit (CRB 15000-5/0.95)

Continued

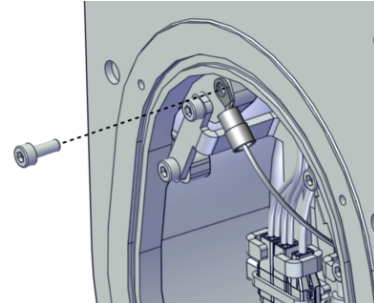
	Action	Note
3	Connect the functional earth cable with the screw.	<p>Hex socket head cap screw: M3x8 12.9 Lafre 2C2B/FC6.9 (1 pcs). Tightening torque: 0.8 Nm</p>  <p>xx2000001936</p>

Refitting the lower arm covers (-5/0.95)

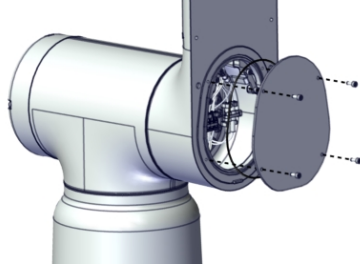
	Action	Note
1	Wipe, lubricate and fit the o-ring to its groove. Replace if damaged.	<p>O-ring: 3HAC061327-044 Grease: 3HAC042536-001 (Shell Gadus S2)</p>  <p>xx2000001954</p>
2	Refit the inner cover with four screws.	<p>Hex socket head cap screw: M3x8 12.9 Lafre 2C2B/FC6.9 (4 pcs) Tightening torque: 1.4 Nm.</p>  <p>xx2000001930</p>

Continues on next page

5.6.1 Replacing the axis-1 joint unit (CRB 15000-5/0.95)

Continued

	Action	Note
3	Snap the lower arm cover into place.	Hex socket head cap screw: M3x16 12.9 Lafre 2C2B/FC6.9 (4 pcs) Tightening torque: 0.45 Nm.
4	Secure the cover with four screws.	

Refitting the swing cover(-5/0.95)

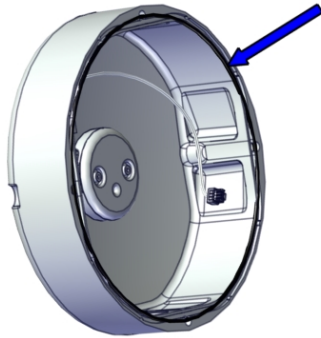
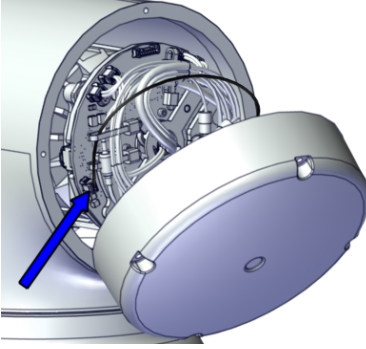
	Action	Note
1	Fit the o-ring to cover groove. Replace if damaged.	O-ring: 3HAC061327-047 (for CRB 15000-5/0.95)  xx2000001962
2	For robots with RobotWare earlier than 7.10 Place the cover at mounting position and reconnect the brake release connector DR.X8 to the drive board. Orient the cover for proper arrangement of the brake release cable.	 xx2000001932

Continues on next page

5 Repair

5.6.1 Replacing the axis-1 joint unit (CRB 15000-5/0.95)

Continued

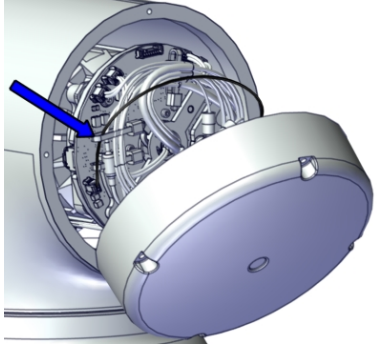
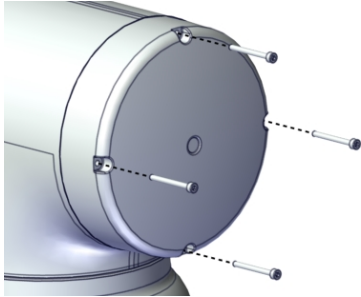
	Action	Note
3	For robots with RobotWare earlier than 7.10 Secure the brake release cable with a cable tie.	Cable ties  xx2000001931
4	Refit the cover with the four screws.	Hex socket head cap screw: M3x30 12.9 Lafre 2C2B/FC6.9 (4 pcs) Tightening torque: 0.45 Nm  xx2000001935

Continues on next page

Concluding procedure

	Action	Note
1	<p>Calibrate the joint unit torque sensor.</p> <ol style="list-style-type: none"> 1 On the FlexPendant, go to the Code app and call the calibration procedure using PP to Routine, not by using Call Routine. 2 Select the Joint Unit Replacement feature and then select the axis to calibrate. 3 The controller is now restarted. Once the home screen of the FlexPendant is shown, press the Play button to continue the calibration routine. 4 The robot moves to a position or positions where measurements are performed. 5 The results of the measurements are presented together with the current values in the controller. Choose whether to save the calibration data or not. 6 If new calibration data is saved you will be asked to do a test with the lead-through functionality active to verify that the sensors work correctly. 7 Finally the robot is moved back to the original position. 8 Test the brake release (movement without drive power) functionality, see Testing the brake release functionality on page 196. 	See Calibration on page 1063
2	<p> DANGER</p> <p>Make sure all safety requirements are met when performing the first test run. See Test run after installation, maintenance, or repair on page 90.</p>	

5 Repair

5.6.2 Replacing the axis-1 joint unit (CRB 15000-10/1.52 and CRB 15000-12/1.27)

5.6.2 Replacing the axis-1 joint unit (CRB 15000-10/1.52 and CRB 15000-12/1.27)

Location of the axis-1 joint unit

The joint unit is located as shown in the figure.

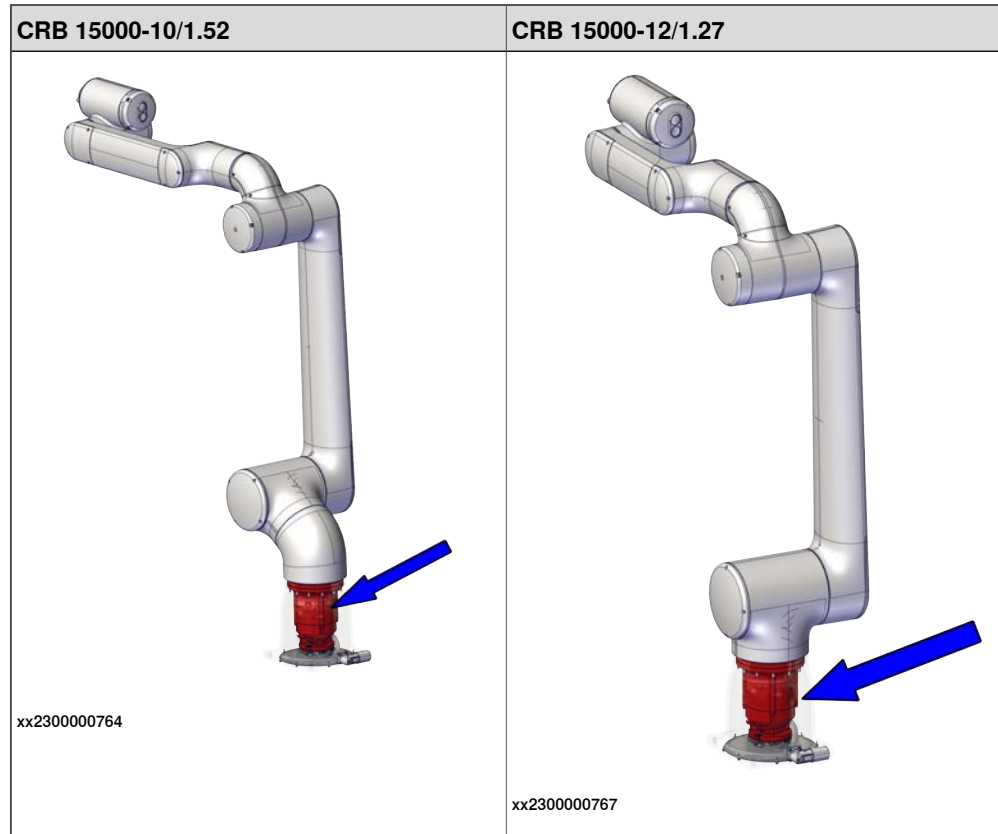

Summary of the replacement procedure

This is a brief summary of the replacement procedure, containing the major actions to be performed.

- 1 Separate the cabling between the swing and the lower arm.
- 2 Remove the lower and upper arm undivided.
- 3 Remove the axis-2 joint unit.
- 4 Remove the swing.
- 5 Loosen the base from the foundation and lay it down on its side.
- 6 Replace the axis-1 joint unit. Move the cabling from old to new joint unit.

Required spare parts



Note

The spare part numbers that are listed in the table can be out of date. See the latest spare parts of the CRB 15000 via myABB Business Portal, www.abb.com/myABB.

Continues on next page

5.6.2 Replacing the axis-1 joint unit (CRB 15000-10/1.52 and CRB 15000-12/1.27)

Continued

Spare part	Article number	Note
Joint unit	3HAC087472-001	Used for CRB 15000-10/1.52 and CRB 15000-12/1.27. New O-rings 3HAC061327-044 and cable tie 3HAC075545-001 are included in the delivery.

Required tools and equipment

Equipment	Article number	Note
Lifting aid	3HAC087787-001	For joint units on axes 1 and 2 of CRB 15000-10/1.52 and CRB 15000-12/1.27. A plate, a beam, a pair of semicircular blocks and attachment screws M5x30 (2 pcs) are enclosed.
Guide pin, M5x125	3HAC087786-001	Always use guide pins in pairs. For joint units on axes 1 and 2 of CRB 15000-10/1.52 and CRB 15000-12/1.27.
Guide pin, M5x75	3HAC087786-002	Always use guide pins in pairs.
Protection plate	3HAC087789-001	For protection of drive board during cabling installation on joint units of CRB 15000-10/1.52 and CRB 15000-12/1.27.
Cable tie gun EVO 7i	-	HellermannTyton 110-77001 or similar
Standard toolkit	-	Content is defined in section Standard toolkit on page 1099 .

Required consumables

Consumable	Article number	Note
Cable ties	-	
O-ring	3HAC061327-072	Base cover, used for CRB 15000-10/1.52 and CRB 15000-12/1.27.
O-ring	3HAC061327-044	Axis-1 and -2 joint unit, used for CRB 15000-10/1.52 and CRB 15000-12/1.27. Replace if damaged.
O-ring	3HAC061327-074	Swing cover, used for CRB 15000-10/1.52 and CRB 15000-12/1.27. Replace if damaged.
O-ring	3HAC061327-075	Lower arm, lower inner cover of CRB 15000-10/1.52 and CRB 15000-12/1.27. Replace if damaged.

Continues on next page

5 Repair



5.6.2 Replacing the axis-1 joint unit (CRB 15000-10/1.52 and CRB 15000-12/1.27)

Continued

Removing the joint unit

Use these procedures to remove the joint unit.

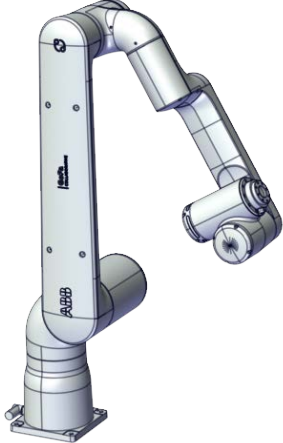
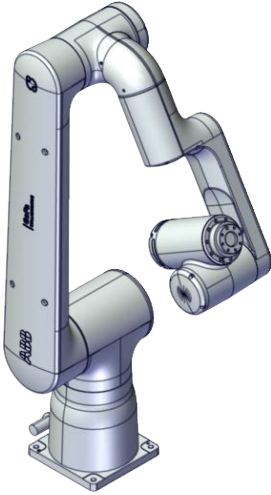
Preparations before removing the joint unit

	Action	Note
1	<p>Jog the robot to the specified position:</p> <ul style="list-style-type: none"> • Axis 1: 0° (home position) • Axis 2: 0° • Axis 3: +60° • Axis 4: 0° • Axis 5: -90° • Axis 6: No significance. <p> CAUTION</p> <p>Jog the axis on which the joint unit is to be replaced to home position, to achieve correct cable routing during replacement of the joint unit.</p>	<p>Valid for CRB 15000-10/1.52</p>  <p>xx2300001062</p> <p>Valid for CRB 15000-12/1.27</p>  <p>xx2300001063</p>
2	<p> CAUTION</p> <p>Turn off all supplies for electrical power to the robot, before starting the repair work.</p>	

Continues on next page

5.6.2 Replacing the axis-1 joint unit (CRB 15000-10/1.52 and CRB 15000-12/1.27)

Continued

Removing the lower arm covers (-10/1.52 and -12/1.27)

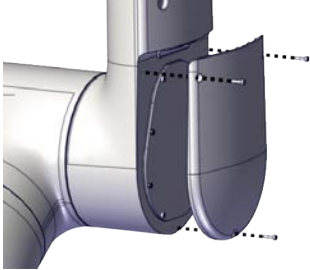
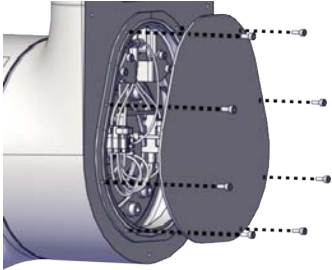
	Action	Note
1	 CAUTION Make sure that all supplies for electrical power are turned off.	
2	Remove the lower cover of lower arm by removing the screws.	 xx2300000812
3	Remove the lower inner cover by removing the screws.	 xx2300000813

Disconnecting the cabling between the lower arm and the swing

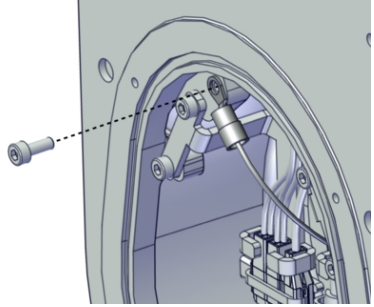
	Action	Note
1	Remove the functional earth cable by removing the screw.	 xx2000001936

Continues on next page

5 Repair

5.6.2 Replacing the axis-1 joint unit (CRB 15000-10/1.52 and CRB 15000-12/1.27)

Continued

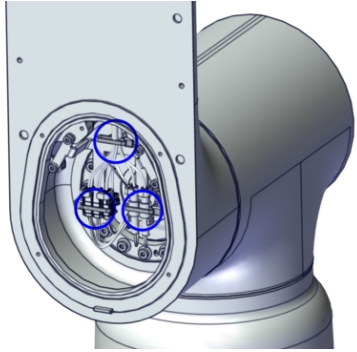
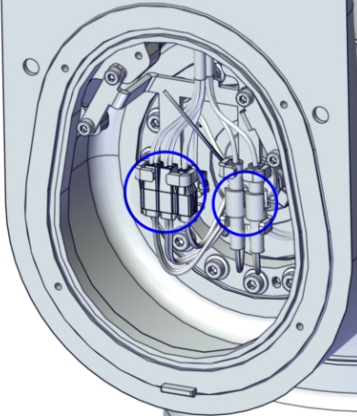
	Action	Note
2	Cut the cable ties.	 <p>xx2000001937</p>
3	Snap loose and disconnect all connectors.	 <p>xx2000001938</p>

Removing the lower and upper arm assembled

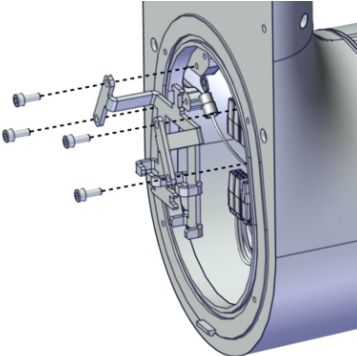
	Action	Note
1	Remove the cable bracket by removing the four screws.	 <p>xx2000001939</p>

Continues on next page

5.6.2 Replacing the axis-1 joint unit (CRB 15000-10/1.52 and CRB 15000-12/1.27)

Continued

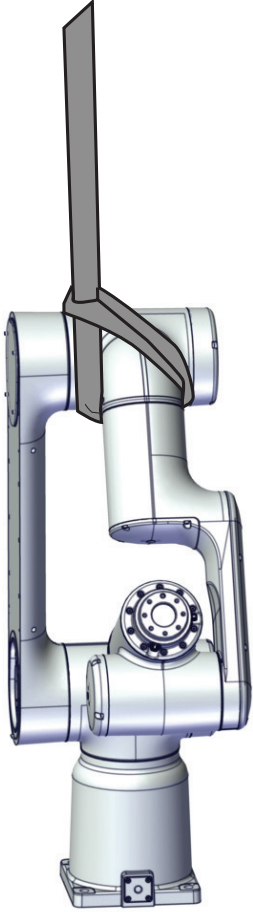

	Action	Note
2	<p>Secure the weight of the upper and lower arm.</p> <p> CAUTION</p> <p>The weight of the complete upper and lower arm together is up to 26 kg</p>	<p>Suggestion with lifting sling and an overhead crane.</p> <p>Example of CRB 15000-5/0.95, similar to CRB 15000-10/1.52 and CRB 15000-12/1.27.</p>  <p>xx210000294</p>

Continues on next page

5 Repair

5.6.2 Replacing the axis-1 joint unit (CRB 15000-10/1.52 and CRB 15000-12/1.27)

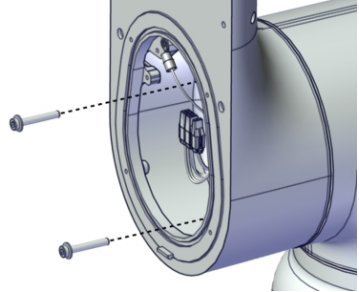
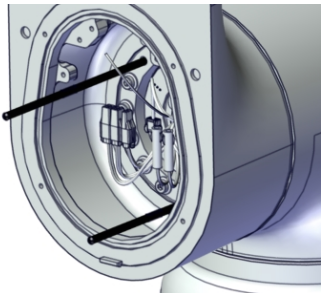
Continued

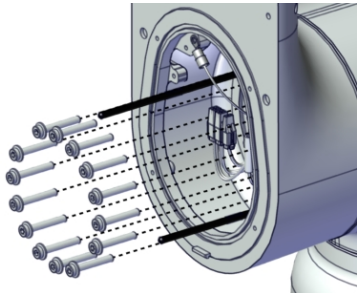
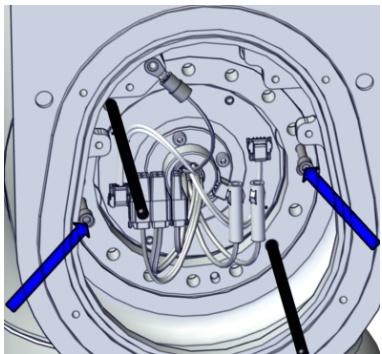
	Action	Note
3	<p>Remove two attachment screws and fit two guide pins to the axis-2 joint unit.</p> <p> CAUTION</p> <p>Do not mix the flange screws used for CRB 15000-5/0.95 and the threaded screws used for CRB 15000-10/1.52 and CRB 15000-12/1.27. Always use washers together with the threaded screws for CRB 15000-10/1.52 and CRB 15000-12/1.27. Illustration is for reference only.</p>	<p>Guide pin, M5x125: 3HAC087786-001</p> <p>Always use guide pins in pairs.</p>  <p>xx2000001951</p>  <p>xx2000001960</p>
4	<p>Remove the lower arm attachment screws.</p> <p> CAUTION</p> <p>Do not mix the flange screws used for CRB 15000-5/0.95 and the threaded screws used for CRB 15000-10/1.52 and CRB 15000-12/1.27. Always use washers together with the threaded screws for CRB 15000-10/1.52 and CRB 15000-12/1.27. Illustration is for reference only.</p>	 <p>xx2000001940</p>
5	<p>Use two fully threaded attachment screws as removal tools to press the lower arm out of position.</p>	 <p>xx2000002151</p>

Continues on next page

5.6.2 Replacing the axis-1 joint unit (CRB 15000-10/1.52 and CRB 15000-12/1.27)

Continued

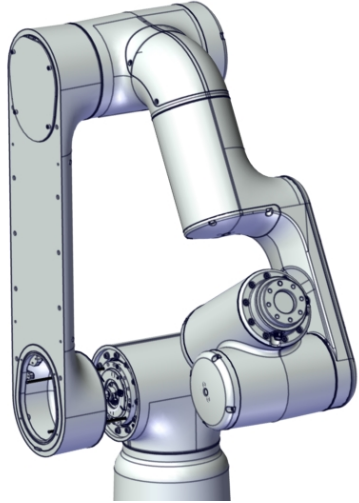
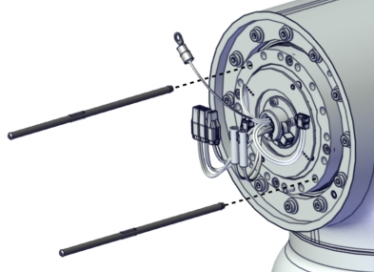
	Action	Note
6	Remove the complete arm system from the swing.	 <p>xx2000001941</p>
7	Remove the guide pins.	 <p>xx2000002432</p>

Removing the swing cover and insert (-10/1.52 and -12/1.27)

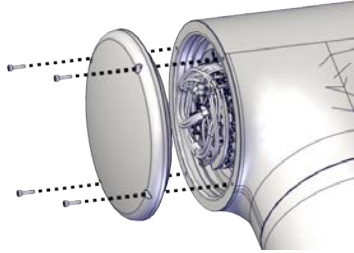
	Action	Note
1	 CAUTION Make sure that all supplies for electrical power are turned off.	
2	Remove the cover by removing the screws.	 <p>xx2300000814</p>

Continues on next page

5 Repair

5.6.2 Replacing the axis-1 joint unit (CRB 15000-10/1.52 and CRB 15000-12/1.27)

Continued

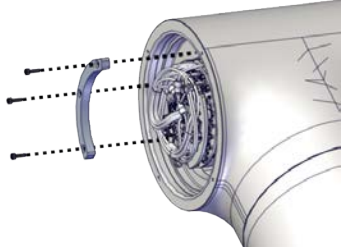
	Action	Note
3	 CAUTION Valid for CRB 15000-5/0.95 There is cabling connected between the cover and the joint unit drive board. Open the cover with care to avoid damage to the cabling or the connector(s). Do not leave the cover in location without being secured with the attachment screws.	
4	Remove the insert.	 xx2300000815

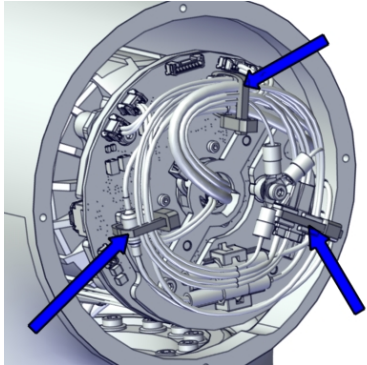

Disconnecting the axis-2 joint unit cabling

	Action	Note
1	 ELECTROSTATIC DISCHARGE (ESD) The unit is sensitive to ESD. Before handling the unit read the safety information in section The unit is sensitive to ESD on page 53 .	
2	Cut the cable ties.	 xx2000001946

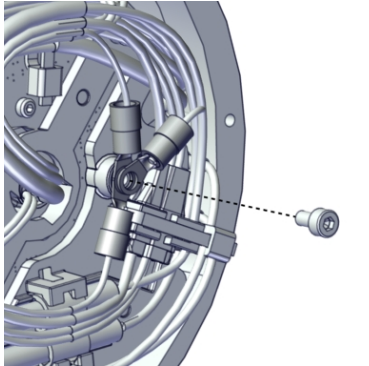
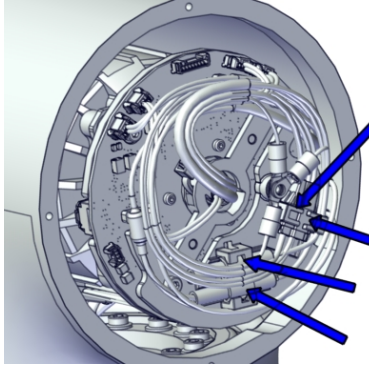

Continues on next page

5.6.2 Replacing the axis-1 joint unit (CRB 15000-10/1.52 and CRB 15000-12/1.27)

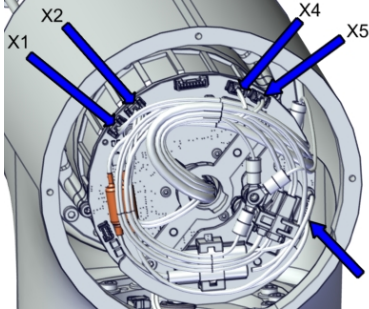
Continued

	Action	Note
3	Remove the functional and protective earth cables by removing the screw.	 <p>xx2000001945</p>
4	Snap loose and disconnect the connectors: <ul style="list-style-type: none"> • J2.DC+ • J2.DC- • J2.CS • J2.CP 	 <p>xx2000001944</p>
5	Disconnect the connectors from the drive board. <ul style="list-style-type: none"> • D2.X1 from X1 • D2.DC+ from DC+ • D2.DC- from ground • D2.X4 from X4 • D2.X2 from X2 • D2.X5 from X5 <p> CAUTION</p> Use tweezers to unlock connectors and pull them off.	 <p>xx2000002013</p>

Removing the base from foundation (-10/1.52 and -12/1.27)



	Action	Note
1	<p> CAUTION</p> The weight of the complete swing and base together is up to 25 kg	
2	<p> WARNING</p> Personnel must not, under any circumstances, be present under the suspended load.	

Continues on next page

5 Repair

5.6.2 Replacing the axis-1 joint unit (CRB 15000-10/1.52 and CRB 15000-12/1.27)

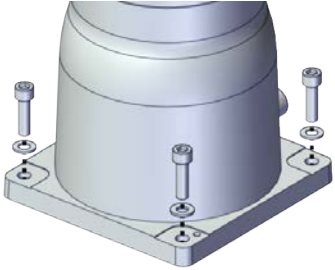
Continued

	Action	Note
3	Loosen the robot base from the foundation by removing the foundation attachment screws.	 <p data-bbox="991 611 1098 629">xx2300001060</p>
4	<p data-bbox="475 667 983 748">Lay the robot down with the torque sensor side upwards on a working bench. Do not damage the base socket. Caution with the cabling.</p> <p data-bbox="480 770 679 815">  CAUTION </p> <p data-bbox="475 837 983 949">The cabling is sensitive to mechanical damage. Handle it with care to avoid damage to the cabling or the connector, avoid any kind of tilt or skew.</p>	



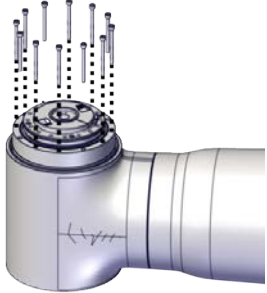

Removing the axis-2 joint unit

	Action	Note
1	Removing the attachment screws.	 <p data-bbox="1027 1413 1134 1431">xx2300000786</p>

Continues on next page

5.6.2 Replacing the axis-1 joint unit (CRB 15000-10/1.52 and CRB 15000-12/1.27)

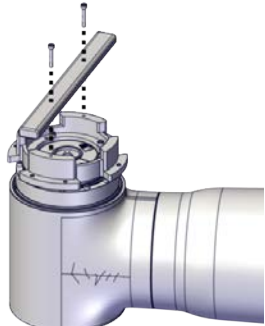
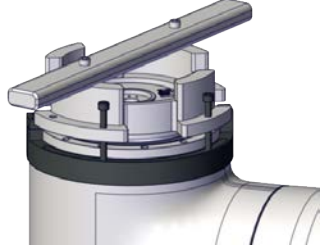
Continued

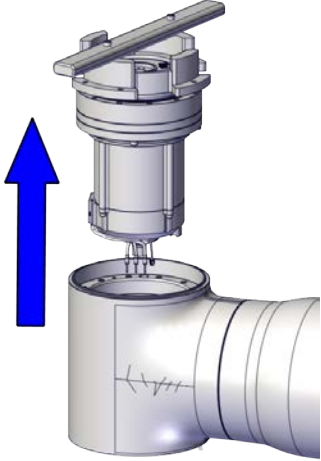
	Action	Note
2	<p>Fit the lifting aid to the joint unit, on the torque sensor side.</p> <p> CAUTION</p> <p>The connectors and the joint unit cables are sensitive to mechanical damage. Handle the assembly with care.</p>	<p>Lifting aid: 3HAC087787-001 Screws: M5x30 (4 pcs for plate and 2 pcs for beam)</p>  <p>xx2300000787</p>  <p>xx2300000788</p>
3	<p>Place the two semicircular blocks surrounding the joint unit, and use two fully threaded attachment screws as removal tools to press the joint unit out of position.</p>	 <p>xx2300000789</p>
4	<p>Remove the joint unit from the swing.</p> <p> CAUTION</p> <p>The connectors and the joint unit cables are sensitive to mechanical damage. Handle the assembly with care.</p>	 <p>xx2300000790</p>

Continues on next page

5 Repair

5.6.2 Replacing the axis-1 joint unit (CRB 15000-10/1.52 and CRB 15000-12/1.27)

Continued

	Action	Note
5	Remove the lifting aid.	 <p>xx2300000778</p> <p>xx2300000776</p>

Securing the base (-10/1.52 and -12/1.27)

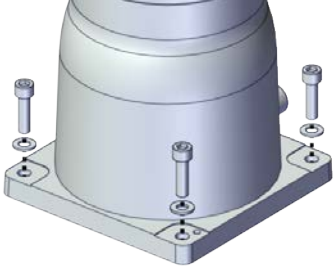

	Action	Note
1	Lift the base to standing and secure it to the foundation with the attachment screws and washers.	<p>Attachment screws: M10x35 8.8 (4 pcs).</p> <p>Washers: 23/10.5/2.5 mm Steel (4 pcs).</p> <p>Tightening torque: 32 Nm \pm10%.</p>  <p>xx2300001060</p>

Continues on next page

5.6.2 Replacing the axis-1 joint unit (CRB 15000-10/1.52 and CRB 15000-12/1.27)

Continued

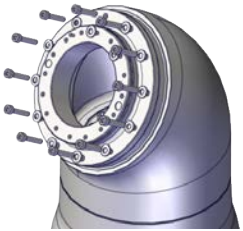
Removing the swing (-10/1.52 and -12/1.27)

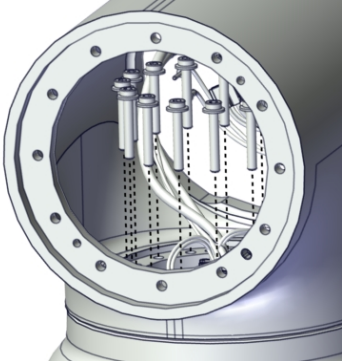

	Action	Note
1	<p>Valid for CRB 15000-10/1.52 Remove the swing transition.</p>	 <p>xx2300000817</p>
2	<p>Valid for CRB 15000-10/1.52 Remove the swing flange.</p>	 <p>xx2300000818</p>
3	<p>Remove the swing attachment screws.</p> <p> CAUTION</p> <p>Do not mix the flange screws used for CRB 15000-5/0.95 and the threaded screws used for CRB 15000-10/1.52 and CRB 15000-12/1.27. Always use washers together with the threaded screws for CRB 15000-10/1.52 and CRB 15000-12/1.27. Illustration is for reference only.</p>	<p>Valid for CRB 15000-10/1.52</p>  <p>xx2300000819</p> <p>Valid for CRB 15000-12/1.27</p>  <p>xx2000001987</p>

Continues on next page

5 Repair

5.6.2 Replacing the axis-1 joint unit (CRB 15000-10/1.52 and CRB 15000-12/1.27)

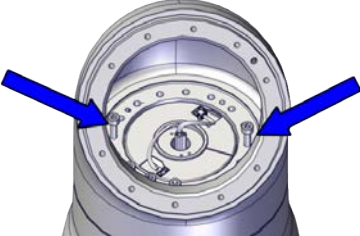
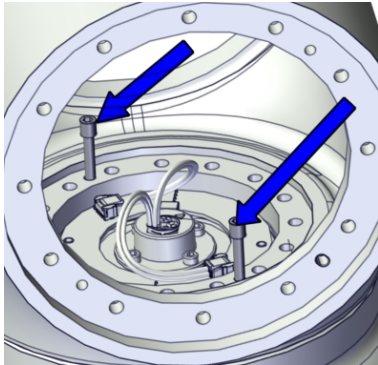
Continued

	Action	Note
4	<p>Use two fully threaded attachment screws as removal tools to press the swing out of position.</p> <p> CAUTION</p> <p>Do not mix the flange screws used for CRB 15000-5/0.95 and the threaded screws used for CRB 15000-10/1.52 and CRB 15000-12/1.27. Always use washers together with the threaded screws for CRB 15000-10/1.52 and CRB 15000-12/1.27. Illustration is for reference only.</p>	<p>Valid for CRB 15000-10/1.52</p>  <p>xx2300000822</p> <p>Valid for CRB 15000-12/1.27</p>  <p>xx2000002152</p>
5	<p>Lift away the swing.</p> <p> CAUTION</p> <p>The torque sensor (on the exposed PCBA) is sensitive to mechanical damage. Handle the assembly with care.</p>	

Loosening the base and removing the base cover

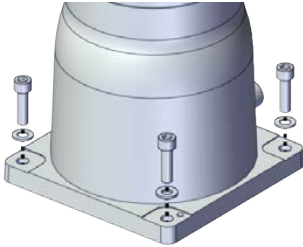
	Action	Note
1	<p>Loosen the base from the foundation by removing the attachment screws and washers.</p>	 <p>xx2300001060</p>

Continues on next page

5.6.2 Replacing the axis-1 joint unit (CRB 15000-10/1.52 and CRB 15000-12/1.27)

Continued

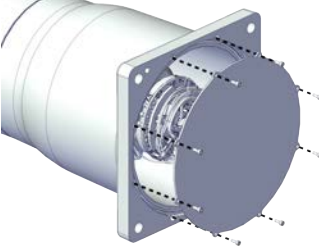
	Action	Note
2	Tilt the base on to its side and remove the bottom cover by removing the attachment screws.	 <p>xx2300000760</p>

Disconnecting the axis-1 joint unit cabling

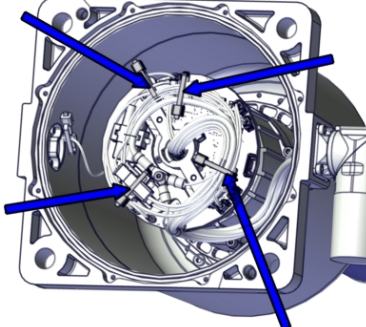
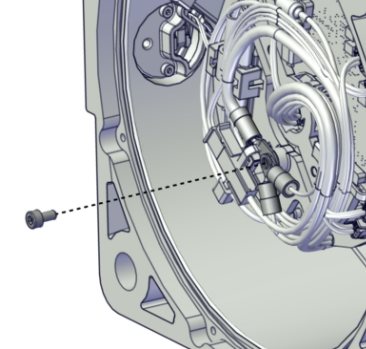
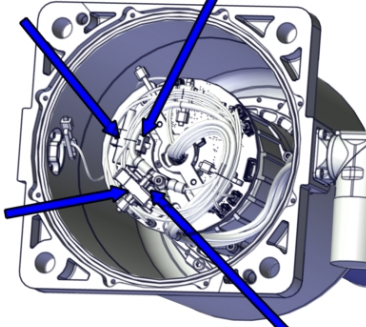
	Action	Note
1	Cut the cable ties.	 <p>xx2000002012</p>
2	Remove the functional and protective earth cables by removing the screw.	 <p>xx2000002011</p>
3	Snap loose and disconnect the connectors: <ul style="list-style-type: none"> • J1.DC+ • J1.DC- • J1.CS • J1.CP 	 <p>xx2000002010</p>

Continues on next page

5 Repair

5.6.2 Replacing the axis-1 joint unit (CRB 15000-10/1.52 and CRB 15000-12/1.27)

Continued

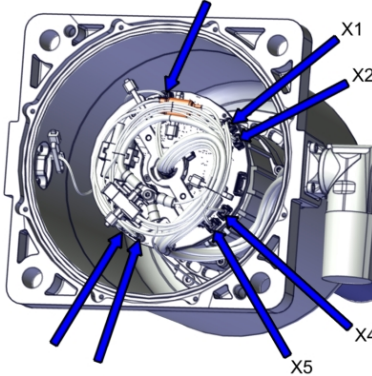
	Action	Note
4	<p>Disconnect the connectors from the drive board.</p> <ul style="list-style-type: none">• D1.X1 from X1• D1.DC+ from DC+• D1.DC- from ground• D1.X4 from X4• D1.X2 from X2• D1.X5 from X5• DR.X8 from X8 <p> CAUTION</p> <p>Use tweezers to unlock connectors and pull them off.</p>	 <p>xx2000002009</p>





Removing the axis-1 joint unit (-10/1.52 and -12/1.27)

	Action	Note
1	Removing the attachment screws.	 <p>xx2300000770</p>

Continues on next page

5.6.2 Replacing the axis-1 joint unit (CRB 15000-10/1.52 and CRB 15000-12/1.27)

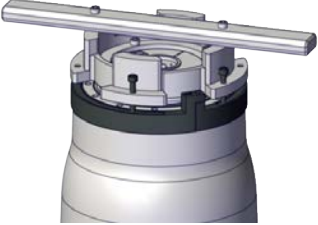
Continued

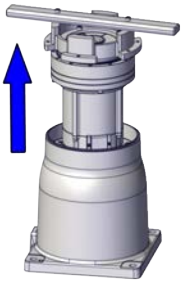
	Action	Note
2	<p>Fit the lifting aid to the joint unit, on the torque sensor side.</p> <p> CAUTION</p> <p>The connectors and the joint unit cables are sensitive to mechanical damage. Handle the assembly with care.</p>	<p>Lifting aid: 3HAC087787-001 Screws: M5x30 (4 pcs for plate and 2 pcs for beam)</p>  <p>xx2300000771</p> <p>xx2300000772</p>
3	<p>Place the two semicircular blocks surrounding the joint unit, and use two fully threaded attachment screws as removal tools to press the joint unit out of position.</p>	 <p>xx2300000773</p>
4	<p>Remove the joint unit from the swing.</p> <p> CAUTION</p> <p>The connectors and the joint unit cables are sensitive to mechanical damage. Handle the assembly with care.</p>	 <p>xx2300000774</p>

Continues on next page



5 Repair

5.6.2 Replacing the axis-1 joint unit (CRB 15000-10/1.52 and CRB 15000-12/1.27)

Continued

	Action	Note
5	Remove the lifting aid.	 <p>xx2300000778</p> <p>xx2300000776</p>

Removing the joint cable

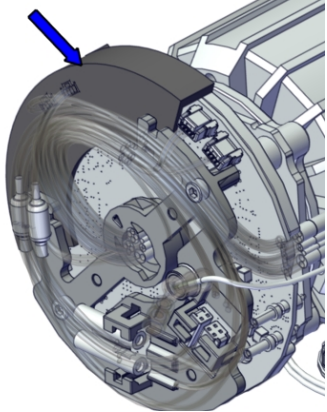
	Action	Note
1	 <p>ELECTROSTATIC DISCHARGE (ESD)</p> <p>The unit is sensitive to ESD. Before handling the unit read the safety information in section <i>The unit is sensitive to ESD on page 53</i>.</p>	
2	<p>Fit the protection plate to the drive board unit.</p>  <p>Tip</p> <p>Using the protection plate is important for protecting the drive board unit. If complete joint unit is to be replaced, the protection plate is not needed.</p>	<p>Protection plate: 3HAC077790-001 (for CRB 15000-5/0.95) / 3HAC087789-001 (for CRB 15000-10/1.52 and CRB 15000-12/1.27)</p>  <p>xx2000002057</p>

Continues on next page

5.6.2 Replacing the axis-1 joint unit (CRB 15000-10/1.52 and CRB 15000-12/1.27)

Continued

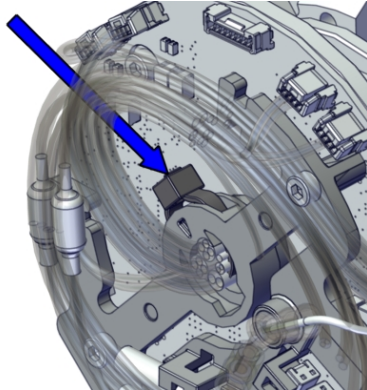
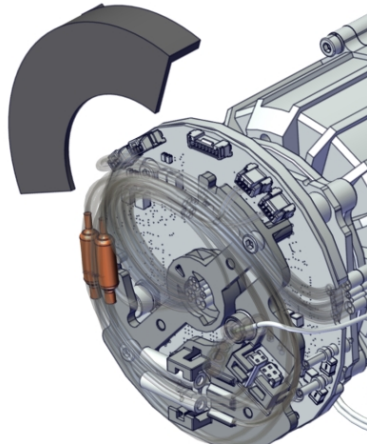
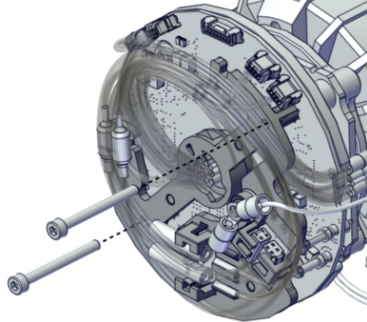
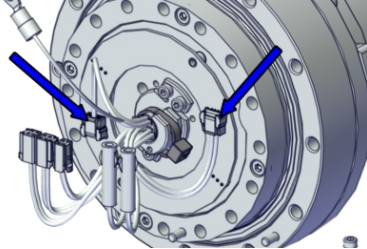

	Action	Note
3	Cut the cable tie at the drive board.	 <p>xx2000002058</p>
4	Remove the protection plate.	 <p>xx2100000301</p>
5	Remove the cable support from the drive board by removing the attachment screws.	 <p>xx2000002055</p>
6	Disconnect the two connectors from the torque sensor board. <ul style="list-style-type: none"> • TQ.A • TQ.B 	 <p>xx2000002053</p>

Continues on next page

5 Repair

5.6.2 Replacing the axis-1 joint unit (CRB 15000-10/1.52 and CRB 15000-12/1.27)

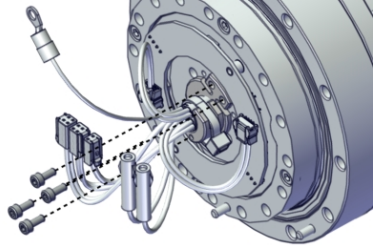

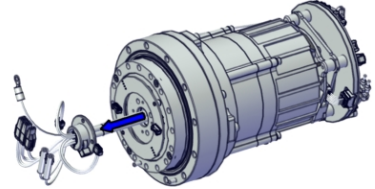
Continued

	Action	Note
7	Remove the cable plate by removing the attachment screws.	 xx2000002049
8	Remove the joint cable from the hollow shaft from the torque sensor side.  CAUTION The connectors and the joint unit cables are sensitive to mechanical damage. Handle the assembly with care.	 xx2000002060

Refitting the joint unit

Use these procedures to refit the joint unit.

Refitting the joint cable

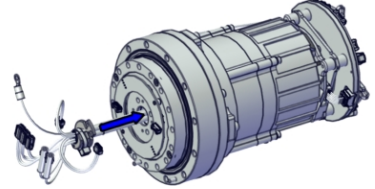
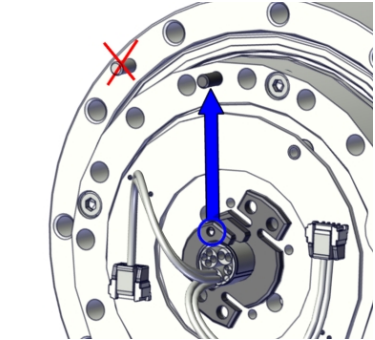
	Action	Note
1	 ELECTROSTATIC DISCHARGE (ESD) The unit is sensitive to ESD. Before handling the unit read the safety information in section The unit is sensitive to ESD on page 53 .	
2	Place the joint cable through the hollow shaft from the torque sensor side.  CAUTION The connectors and the joint unit cables are sensitive to mechanical damage. Handle the assembly with care.	 xx2000002048
3	Orient the cable plate according to the figure. The circle on the cable plate should point towards the guide pin on the torque sensor.	 xx2000002051

Continues on next page

5.6.2 Replacing the axis-1 joint unit (CRB 15000-10/1.52 and CRB 15000-12/1.27)

Continued

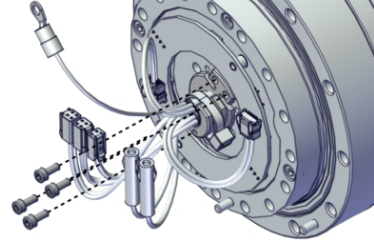
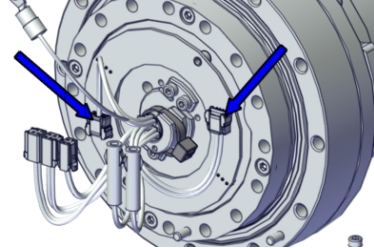
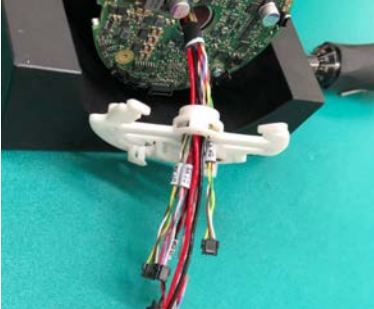
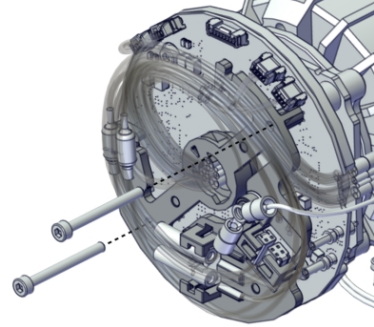
	Action	Note
4	Secure the cable plate to the joint unit with the attachment screws.	<p>Hex socket head cap screw: M2.5x6 12.9 Lafre 2C2B/FC6.9 (4 pcs) Tightening torque: 0.45 Nm.</p>  <p>xx2000002049</p>
5	<p>Connect the two connectors to the torque sensor board.</p> <ul style="list-style-type: none"> • TQ.A to CH1/A • TQ.B to CH2/B 	 <p>xx2000002053</p>
6	Insert the cabling through the cable support and fit the support to the drive board with the attachment screws.	 <p>xx2000002056</p> <p>Hex socket head cap screw: M3x30 12.9 Lafre 2C2B/FC6.9 (2 pcs) Tightening torque: 0.45 Nm.</p>  <p>xx2000002055</p>

Continues on next page

5 Repair

5.6.2 Replacing the axis-1 joint unit (CRB 15000-10/1.52 and CRB 15000-12/1.27)

Continued

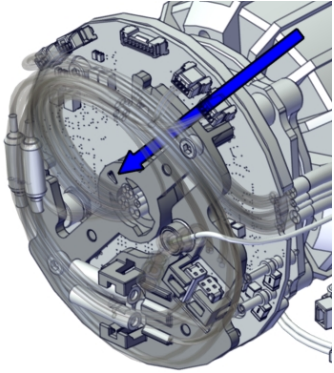
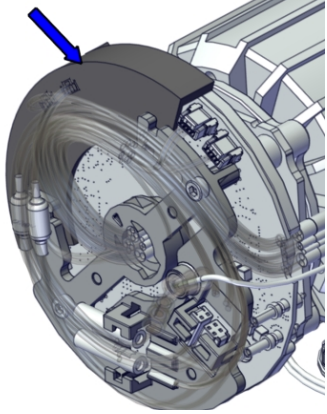
	Action	Note
7	Keep the cabling loose, making sure not to twist or strain it. Use the cable tie to pre-fix the cable by hand.	 xx2100000507
8	Fit the protection plate to the drive board unit.	Protection plate: 3HAC077790-001 (for CRB 15000-5/0.95) / 3HAC087789-001 (for CRB 15000-10/1.52 and CRB 15000-12/1.27)  xx2000002057

Continues on next page

5.6.2 Replacing the axis-1 joint unit (CRB 15000-10/1.52 and CRB 15000-12/1.27)

Continued

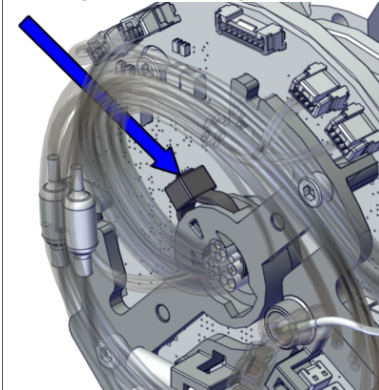
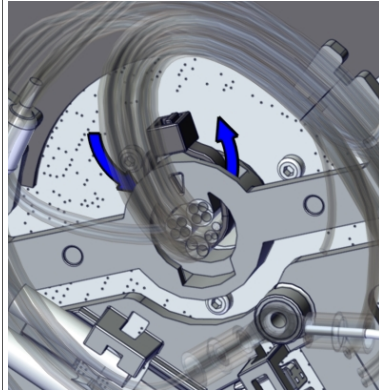
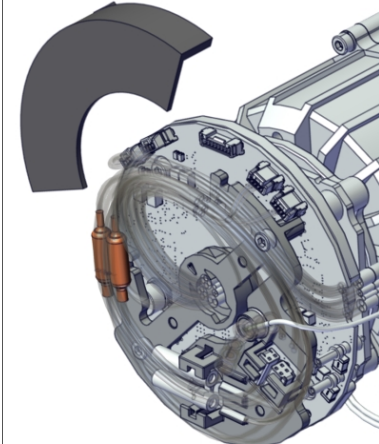
	Action	Note
9	<p>Secure the cables to the cable support with a cable tie, using a cable tie gun.</p> <p>Assembly direction for the cable tie is shown in the figure.</p>	<p>Cable tie: 3HAC075545-001. For securing joint unit cable.</p> <p>Cable tie gun EVO 7i</p> <p>Setting for cable tie gun: 6.75.</p>  <p>xx2000002058</p>  <p>xx2000002059</p>
10	<p>Remove the protection plate.</p>	 <p>xx2100000301</p>

Continues on next page

5 Repair

5.6.2 Replacing the axis-1 joint unit (CRB 15000-10/1.52 and CRB 15000-12/1.27)

Continued

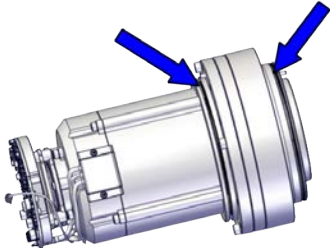
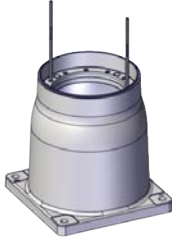

Refitting the axis-1 joint unit (-10/1.52 and -12/1.27)

	Action	Note
1	 <p>ELECTROSTATIC DISCHARGE (ESD)</p> <p>The unit is sensitive to ESD. Before handling the unit read the safety information in section <i>The unit is sensitive to ESD on page 53</i>.</p>	
2	<p>Check the o-rings. Replace if damaged.</p>	<p>O-ring: 3HAC061327-044</p>  <p>xx2300000823</p>
3	<p>Fit two guide pins to the base.</p>	<p>Guide pin, M5x125: 3HAC087786-001</p> <p>Always use guide pins in pairs.</p> <p>For joint units on axes 1 and 2 of CRB 15000-10/1.52 and CRB 15000-12/1.27.</p>  <p>xx2300000775</p>

Continues on next page

5.6.2 Replacing the axis-1 joint unit (CRB 15000-10/1.52 and CRB 15000-12/1.27)

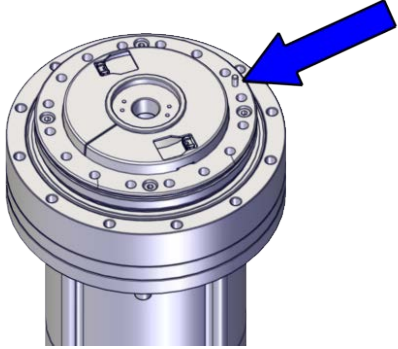
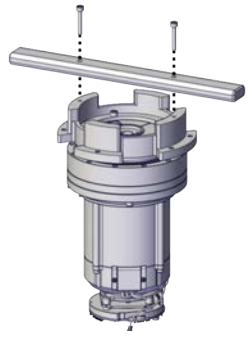
Continued

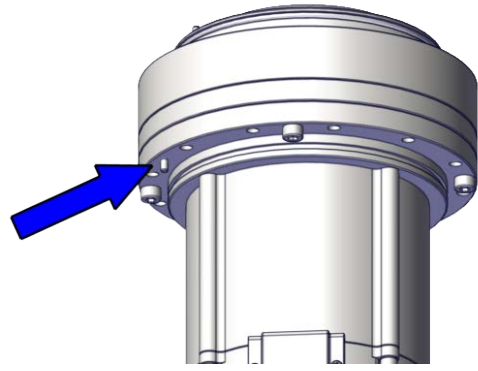
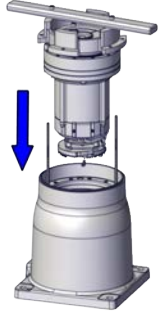



	Action	Note
4	<p>Fit the lifting aid to the joint unit, aligning the pin with the pin hole.</p> <p> CAUTION</p> <p>The connectors and the joint unit cables are sensitive to mechanical damage. Handle the assembly with care.</p>  <p>xx2300000777</p>	<p>Joint unit: 3HAC087472-001 Lifting aid: 3HAC087787-001 Screws: M5x30 (4 pcs for plate and 2 pcs for beam)</p>  <p>xx2300000778</p>  <p>xx2300000776</p>
5	<p>Fit the joint unit to the base, aligning the pin with the pin hole.</p> <p> CAUTION</p> <p>The connectors and the joint unit cables are sensitive to mechanical damage. Handle the assembly with care.</p>  <p>xx2300000780</p>	 <p>xx2300000779</p>

Continues on next page

5 Repair

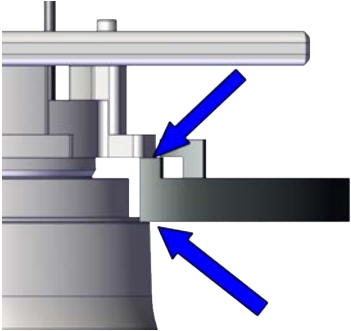
5.6.2 Replacing the axis-1 joint unit (CRB 15000-10/1.52 and CRB 15000-12/1.27)

Continued

	Action	Note
6	<p>Check the joint unit position by placing the lower boss of one semicircular block between the lifting aid and base.</p> <p>The joint unit is properly placed when no gaps between the block and both lifting aid and base</p>	 <p>xx2300000781</p>
7	<p>Remove the guide pins.</p>	 <p>xx2300000782</p>
8	<p>Secure with four attachment screws and pre-tighten the screws crosswise.</p>	 <p>xx2300000783</p>
9	<p>Remove the lifting aid by removing the screws.</p>	 <p>xx2300000784</p>

Continues on next page

5.6.2 Replacing the axis-1 joint unit (CRB 15000-10/1.52 and CRB 15000-12/1.27)

Continued

	Action	Note
10	Secure the joint unit with the remaining attachment screws.	Hex socket head cap screw: 3HAB3409-20  xx2300000785
11	Torque tighten all screws crosswise.	M5x55 12.9 Lafre 2C2B/FC6.9, 12 pcs Tightening torque: 8.2 Nm.

Connecting the axis-1 joint unit cabling

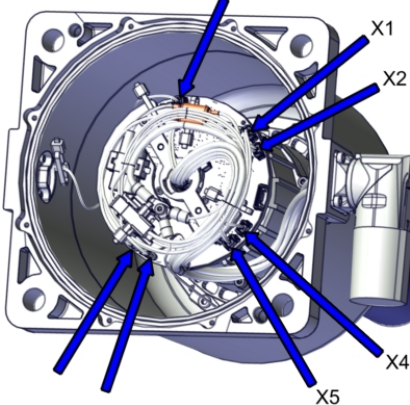
	Action	Note
1	 ELECTROSTATIC DISCHARGE (ESD) The unit is sensitive to ESD. Before handling the unit read the safety information in section The unit is sensitive to ESD on page 53.	
2	Reconnect the connectors to the drive board. <ul style="list-style-type: none"> • D1.X1 to X1 • D1.DC+ to DC+ • D1.DC- to Ground • D1.X4 to X4 • D1.X2 to X2 • D1.X5 to X5 • DR.X8 to X8 	 xx2000002009

Continues on next page

5 Repair

5.6.2 Replacing the axis-1 joint unit (CRB 15000-10/1.52 and CRB 15000-12/1.27)

Continued

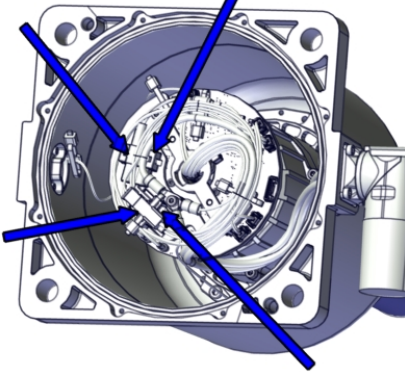
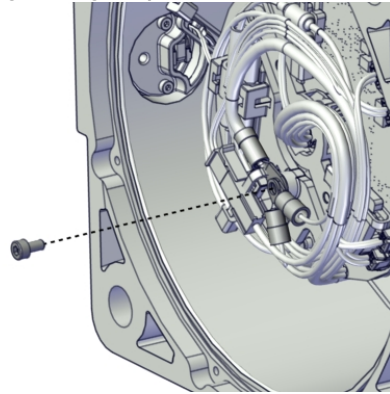
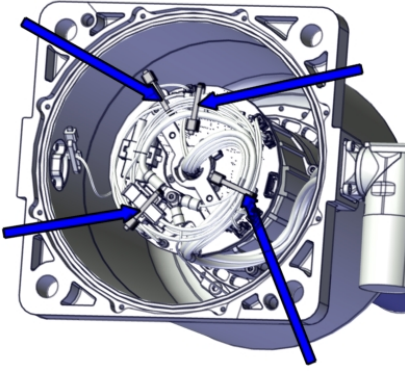

	Action	Note
3	<p>Connect the connectors to each other and snap them to the cable holders.</p> <ul style="list-style-type: none">• J1.DC+ to J1.DC+• J1.DC- to J1.DC-• J1.CS to J1.CS• J1.CP to J1.CP	 <p>xx2000002010</p>
4	<p>Secure the cables for functional earth and protective earth with a screw.</p>	<p>Hex socket head cap screw: M3x6 (1 pcs). Tightening torque: 0.8 Nm.</p>  <p>xx2000002011</p>
5	<p>Secure the cabling with cable ties.</p>	<p>Cable ties (4 pcs)</p>  <p>xx2000002012</p>

Continues on next page

5.6.2 Replacing the axis-1 joint unit (CRB 15000-10/1.52 and CRB 15000-12/1.27)

Continued

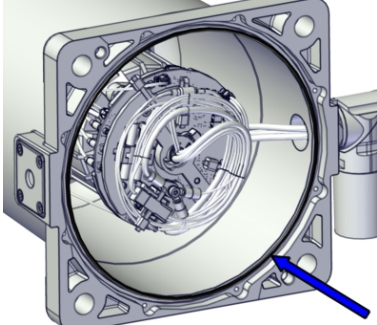
Refitting the base cover (-10/1.52 and -12/1.27)

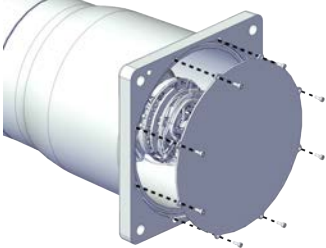
	Action	Note
1	Wipe, lubricate and fit the o-ring to its groove. Replace if damaged.	3HAC061327-072 Grease: 3HAC042536-001 (Shell Gadus S2)  xx2000002016
2	Refit the bottom cover with the attachment screws.  Note For CRB 15000-5/0.95, fit the cover in correct direction, the protrusion of the cover must face outwards.	Hex socket head cap screw: M3x8 12.9 Lafre 2C2B/FC6.9 (8 pcs) Tightening torque: 1.4 Nm.  xx2300000760

Securing the base (-10/1.52 and -12/1.27)

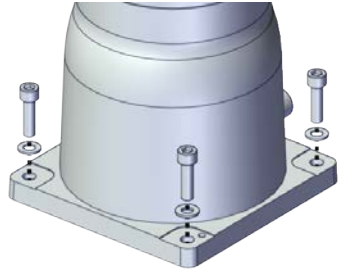
	Action	Note
1	Lift the base to standing and secure it to the foundation with the attachment screws and washers.	Attachment screws: M10x35 8.8 (4 pcs). Washers: 23/10.5/2.5 mm Steel (4 pcs). Tightening torque: 32 Nm ±10%.  xx2300001060

Continues on next page

5 Repair

5.6.2 Replacing the axis-1 joint unit (CRB 15000-10/1.52 and CRB 15000-12/1.27)

Continued

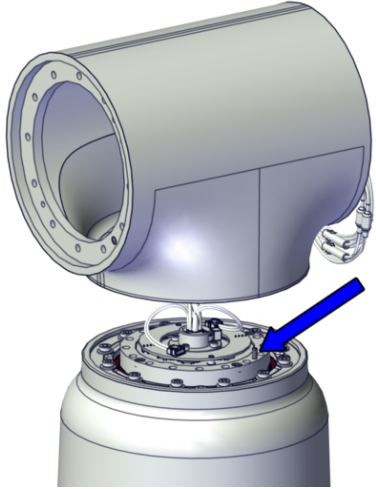

Refitting the swing(-10/1.52 and -12/1.27)

	Action	Note
1	Fit two guide pins on the base unit for position guidance. Always use guide pins in pairs.	Valid for CRB 15000-10/1.52 Guide pin, M5x75, 3HAC087786-002 Valid for CRB 15000-12/1.27 Guide pin, M5x125: 3HAC087786-001
2	Refit the swing to the base unit, aligning the pin with the pin hole.  CAUTION The torque sensor (on the exposed PCBA) is sensitive to mechanical damage. Handle the assembly with care.	Example of CRB 15000-12/1.27, similar to CRB 15000-10/1.52.  xx2000001989

Continues on next page

5.6.2 Replacing the axis-1 joint unit (CRB 15000-10/1.52 and CRB 15000-12/1.27)

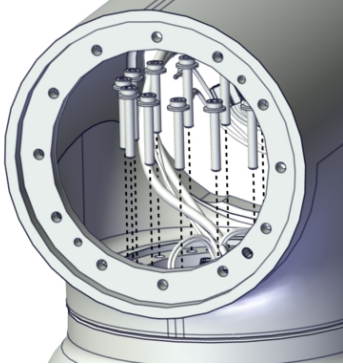
Continued



	Action	Note
3	<p>Secure the swing with the attachment screws.</p> <p> CAUTION</p> <p>Do not mix the flange screws used for CRB 15000-5/0.95 and the threaded screws used for CRB 15000-10/1.52 and CRB 15000-12/1.27. Always use washers together with the threaded screws for CRB 15000-10/1.52 and CRB 15000-12/1.27. Illustration is for reference only.</p>	<p>Hex socket head cap screw: M5x30 12.9 Lafre 2C2B/FC6.9 (16 pcs) Tightening torque: 8.2 Nm Valid for CRB 15000-12/1.27</p>  <p>xx2000001987</p> <p>Valid for CRB 15000-10/1.52</p>  <p>xx2300000819</p>
4	<p>Valid for CRB 15000-10/1.52</p> <p>Check the o-rings on both side of the swing flange. Replace if damaged.</p>	<p>O-ring: 3HAC061327-073 O-ring: 3HAC061327-044</p>  <p>xx2300000821</p>
5	<p>Valid for CRB 15000-10/1.52</p> <p>Refit the swing flange with the attachment screws. Always check the serial number printed on the swing parts and use the parts in the same number for refitting.</p> <p> CAUTION</p> <p>Do not use the pre-assembling screws of swing parts for securing.</p>	<p>Hex socket head cap screw: M5x25 12.9 Lafre 2C2B/FC6.9 (16 pcs) Tightening torque: 8.2 Nm</p>  <p>xx2300000818</p>

Continues on next page

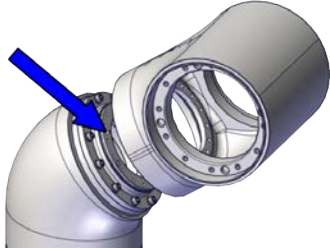

5 Repair

5.6.2 Replacing the axis-1 joint unit (CRB 15000-10/1.52 and CRB 15000-12/1.27)

Continued

	Action	Note
6	<p>Valid for CRB 15000-10/1.52</p> <p>Fit two guide pins on the swing flange for position guidance.</p> <p>Always use guide pins in pairs.</p>	<p>Guide pin, M5x75, 3HAC087786-002</p>
7	<p>Valid for CRB 15000-10/1.52</p> <p>Refit the swing transition to the swing flange, aligning the pin with the pin hole.</p> <p>Always check the serial number printed on the swing parts and use the parts in the same number for refitting.</p>	 <p>xx2300000820</p>
8	<p>Valid for CRB 15000-10/1.52</p> <p>Secure the swing transition with the attachment screws.</p> <p> CAUTION</p> <p>Do not use the pre-assembling screws of swing parts for securing.</p>	<p>Hex socket head cap screw: M5x25 12.9 Lafre 2C2B/FC6.9 (16 pcs)</p> <p>Tightening torque: 8.2 Nm</p>  <p>xx2300000817</p>

Removing the base from foundation (-10/1.52 and -12/1.27)

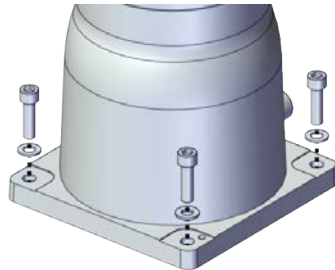
	Action	Note
1	<p> CAUTION</p> <p>The weight of the complete swing and base together is up to 25 kg</p>	
2	<p> WARNING</p> <p>Personnel must not, under any circumstances, be present under the suspended load.</p>	
3	<p>Loosen the robot base from the foundation by removing the foundation attachment screws.</p>	 <p>xx2300001060</p>

Continues on next page

5.6.2 Replacing the axis-1 joint unit (CRB 15000-10/1.52 and CRB 15000-12/1.27)

Continued

	Action	Note
4	<p>Lay the robot down with the torque sensor side upwards on a working bench. Do not damage the base socket. Caution with the cabling.</p> <p> CAUTION</p> <p>The cabling is sensitive to mechanical damage. Handle it with care to avoid damage to the cabling or the connector, avoid any kind of tilt or skew.</p>	

Refitting the axis-2 joint unit (-10/1.52 and -12/1.27)

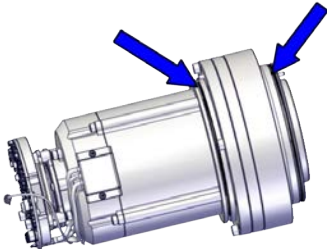
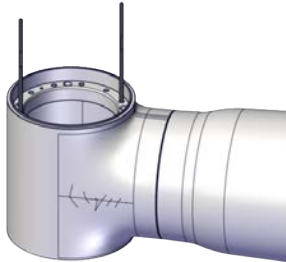

	Action	Note
1	<p> ELECTROSTATIC DISCHARGE (ESD)</p> <p>The unit is sensitive to ESD. Before handling the unit read the safety information in section The unit is sensitive to ESD on page 53.</p>	
2	<p>Check the o-rings. Replace if damaged.</p>	<p>O-ring: 3HAC061327-044</p>  <p>xx2300000823</p>
3	<p>Fit two guide pins to the swing.</p>	<p>Guide pin, M5x125: 3HAC087786-001</p> <p>Always use guide pins in pairs.</p> <p>For joint units on axes 1 and 2 of CRB 15000-10/1.52 and CRB 15000-12/1.27.</p>  <p>xx2300000791</p>

Continues on next page

5 Repair

5.6.2 Replacing the axis-1 joint unit (CRB 15000-10/1.52 and CRB 15000-12/1.27)

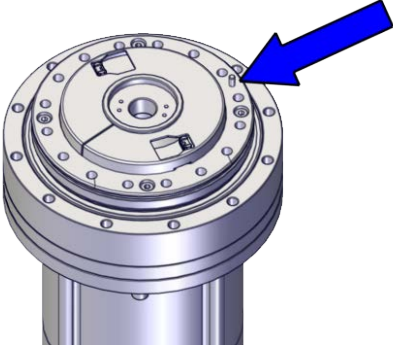
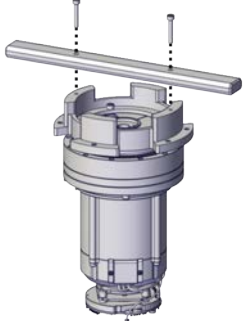
Continued

	Action	Note
4	<p>Fit the lifting aid to the joint unit, aligning the pin with the pin hole.</p> <p> CAUTION</p> <p>The connectors and the joint unit cables are sensitive to mechanical damage. Handle the assembly with care.</p>  <p>xx2300000777</p>	<p>Joint unit: 3HAC087472-001 Lifting aid: 3HAC087787-001 Screws: M5x30 (4 pcs for plate and 2 pcs for beam)</p>  <p>xx2300000778</p>  <p>xx2300000776</p>
5	<p>Place the axis-1 cabling properly to avoid squeezing by the joint unit when putting the joint unit into the swing.</p> <p> CAUTION</p> <p>The cabling is sensitive to mechanical damage. Handle it with care to avoid damage to the cabling or the connector, avoid any kind of tilt or skew.</p>	

Continues on next page

5.6.2 Replacing the axis-1 joint unit (CRB 15000-10/1.52 and CRB 15000-12/1.27)

Continued

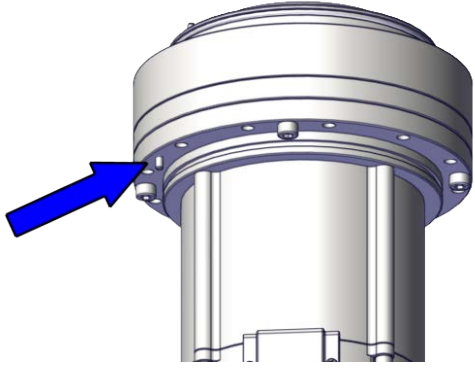
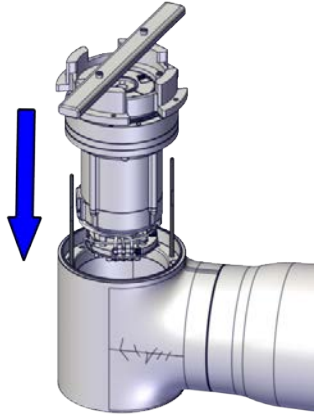
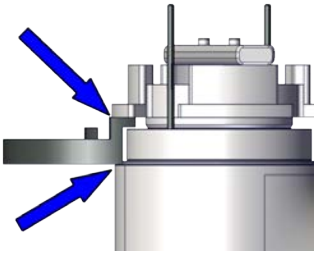
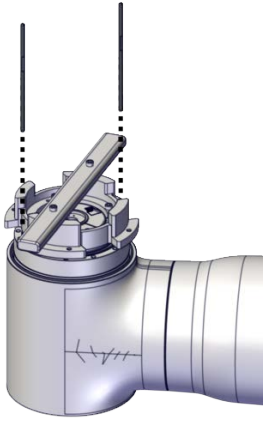
	Action	Note
6	<p>Fit the joint unit to the swing, aligning the pin with the pin hole.</p> <p> CAUTION</p> <p>The connectors and the joint unit cables are sensitive to mechanical damage. Handle the assembly with care.</p>  <p>xx2300000780</p>	 <p>xx2300000792</p>
7	<p>Check the joint unit position by placing the higher boss of one semicircular block between the lifting aid and swing.</p> <p>The joint unit is properly placed when no gaps between the block and both lifting aid and swing.</p>	 <p>xx2300000794</p>
8	<p>Remove the guide pins.</p>	 <p>xx2300000795</p>

Continues on next page

5 Repair

5.6.2 Replacing the axis-1 joint unit (CRB 15000-10/1.52 and CRB 15000-12/1.27)

Continued

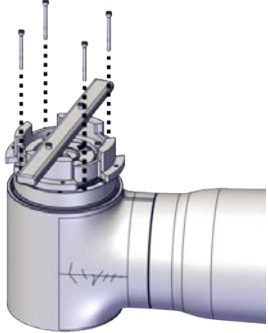
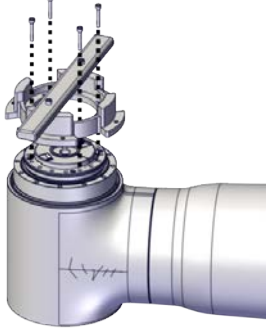
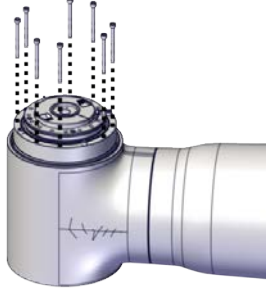
	Action	Note
9	Secure with four attachment screws and pre-tighten the screws crosswise.	 <p>xx2300000796</p>
10	Remove the lifting aid by removing the screws.	 <p>xx2300000797</p>
11	Secure the joint unit with the remaining attachment screws.	<p>Hex socket head cap screw: 3HAB3409-20</p>  <p>xx2300000798</p>
12	Torque tighten all screws crosswise.	<p>M5x55 12.9 Lafre 2C2B/FC6.9, 12 pcs Tightening torque: 8.2 Nm.</p>

Continues on next page



5.6.2 Replacing the axis-1 joint unit (CRB 15000-10/1.52 and CRB 15000-12/1.27)

Continued

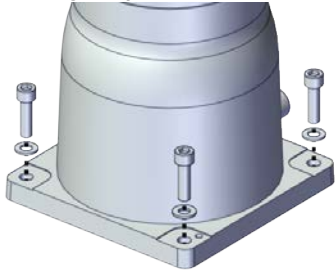
Securing the base (-10/1.52 and -12/1.27)

	Action	Note
1	Lift the base to standing and secure it to the foundation with the attachment screws and washers.	<p>Attachment screws: M10x35 8.8 (4 pcs). Washers: 23/10.5/2.5 mm Steel (4 pcs). Tightening torque: 32 Nm ±10%.</p>  <p>xx2300001060</p>

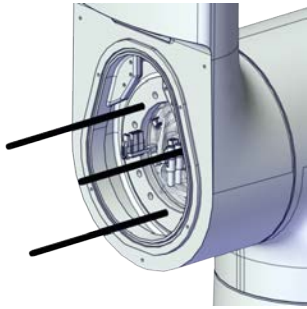
Refitting the lower and upper arm assembled (-10/1.52 and -12/1.27)





	Action	Note
1	Fit three guide pins to the axis-2 joint unit.	<p>Guide pin, M5x125: 3HAC087786-001</p>  <p>xx2300001021</p>
2	<p> CAUTION</p> <p>The weight of the complete upper and lower arm together is up to 26 kg</p>	

Continues on next page

5 Repair

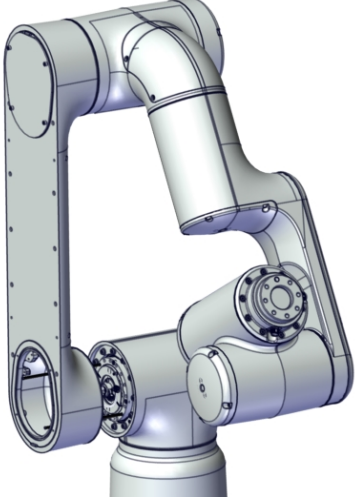
5.6.2 Replacing the axis-1 joint unit (CRB 15000-10/1.52 and CRB 15000-12/1.27)

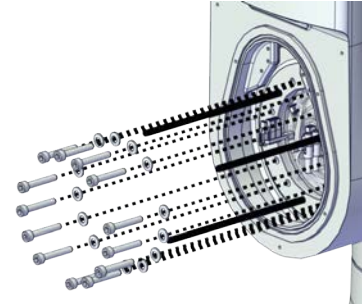
Continued

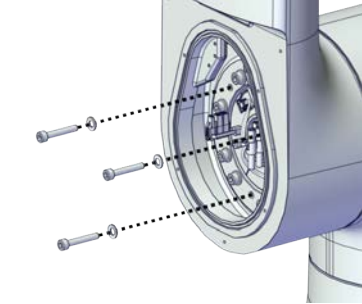
	Action	Note
3	Lift the upper and lower arm assembly to mounting position and slide it onto the guide pins.	<p>Example of CRB 15000-5/0.95, similar to CRB 15000-10/1.52 and CRB 15000-12/1.27.</p>  <p>xx2000001941</p>
4	<p>Secure the lower arm to the swing with all screws and washers but two.</p> <p>Pre-tighten the screws crosswise firstly.</p> <p> CAUTION</p> <p>Do not mix the flange screws used for CRB 15000-5/0.95 and the threaded screws used for CRB 15000-10/1.52 and CRB 15000-12/1.27. Always use washers together with the threaded screws for CRB 15000-10/1.52 and CRB 15000-12/1.27. Illustration is for reference only.</p>	<p>Hex socket head cap screw: M5x30 12.9 Lafre 2C2B/FC6.9, 16 pcs</p>  <p>xx2300001022</p>
5	<p>Remove the guide pins and fasten the remaining two screws and washers.</p> <p> CAUTION</p> <p>Do not mix the flange screws used for CRB 15000-5/0.95 and the threaded screws used for CRB 15000-10/1.52 and CRB 15000-12/1.27. Always use washers together with the threaded screws for CRB 15000-10/1.52 and CRB 15000-12/1.27. Illustration is for reference only.</p>	<p>Hex socket head cap screw: M5x30 12.9 Lafre 2C2B/FC6.9, 16 pcs</p>  <p>xx2300001023</p>
6	Torque tighten all screws crosswise.	Tightening torque: 8.2 Nm

Continues on next page

5.6.2 Replacing the axis-1 joint unit (CRB 15000-10/1.52 and CRB 15000-12/1.27)

Continued

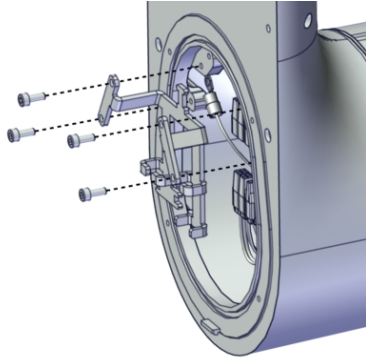
	Action	Note
7	Refit the cable bracket with four screws.	Hex socket head cap screw: M3x8 12.9 Lafre 2C2B/FC6.9 (4 pcs). Tightening torque: 0.8 Nm  xx2000001939

Connecting the axis-2 joint unit cabling

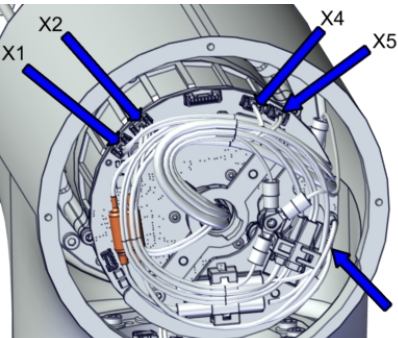
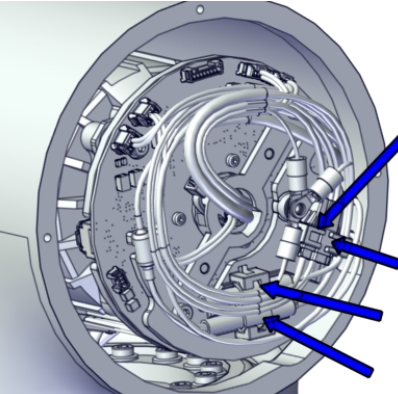
	Action	Note
1	 ELECTROSTATIC DISCHARGE (ESD) The unit is sensitive to ESD. Before handling the unit read the safety information in section The unit is sensitive to ESD on page 53 .	
2	Reconnect the connectors to the drive board. <ul style="list-style-type: none"> • D2.X1 to X1 • D2.DC+ to DC+ • D2.DC- to Ground • D2.X4 to X4 • D2.X2 to X2 • D2.X5 to X5 	 xx2000002013
3	Connect the connectors to each other and snap them to the cable holders. <ul style="list-style-type: none"> • J2.DC+ to J2.DC+ • J2.DC- to J2.DC- • J2.CS to J2.CS • J2.CP to J2.CP 	 xx2000001944

Continues on next page

5 Repair

5.6.2 Replacing the axis-1 joint unit (CRB 15000-10/1.52 and CRB 15000-12/1.27)

Continued

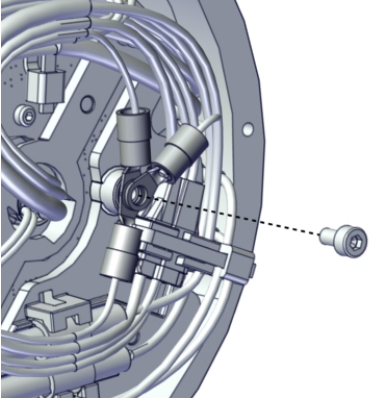
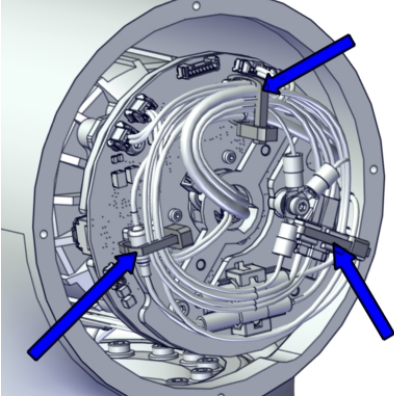
	Action	Note
4	Secure the cables for functional earth and protective earth with a screw.	<p>Hex socket head cap screw: M3x6 (1 pcs). Tightening torque: 0.8 Nm.</p>  <p>xx2000001945</p>
5	Secure the cabling with cable ties.	<p>Cable ties (3 pcs)</p>  <p>xx2000001946</p>

Connecting the cabling between the lower arm and swing

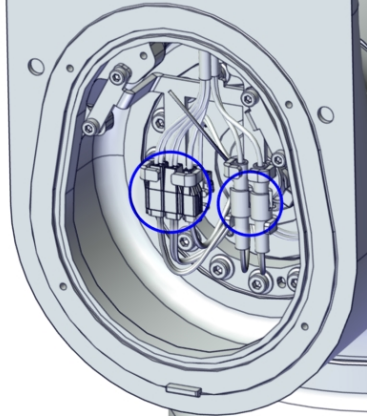
	Action	Note
1	Connect the connectors to each other and snap them to the cable holders.	 <p>xx2000001938</p>

Continues on next page

5.6.2 Replacing the axis-1 joint unit (CRB 15000-10/1.52 and CRB 15000-12/1.27)

Continued

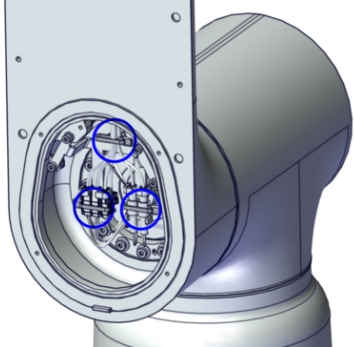
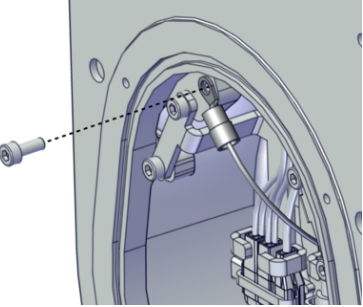
	Action	Note
2	Secure the cabling with cable ties.	<p>Cable ties (3 pcs)</p>  <p>xx2000001937</p>
3	Connect the functional earth cable with the screw.	<p>Hex socket head cap screw: M3x8 12.9 Lafre 2C2B/FC6.9 (1 pcs). Tightening torque: 0.8 Nm</p>  <p>xx2000001936</p>

Removing the lower arm covers (-10/1.52 and -12/1.27)

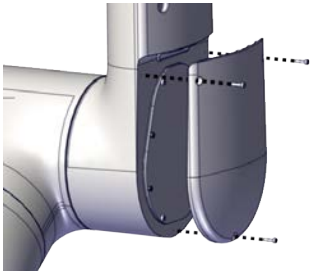
	Action	Note
1	 CAUTION Make sure that all supplies for electrical power are turned off.	
2	Remove the lower cover of lower arm by removing the screws.	 <p>xx2300000812</p>

Continues on next page



5 Repair

5.6.2 Replacing the axis-1 joint unit (CRB 15000-10/1.52 and CRB 15000-12/1.27)

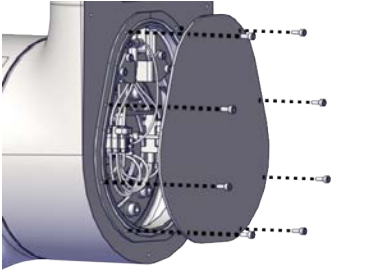
Continued

	Action	Note
3	Remove the lower inner cover by removing the screws.	 <p>xx2300000813</p>

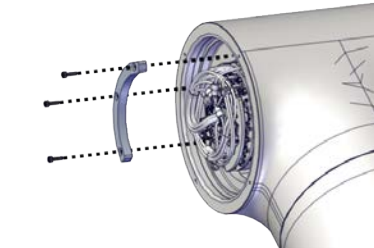
Refitting the swing cover and insert(-10/1.52 and -12/1.27)

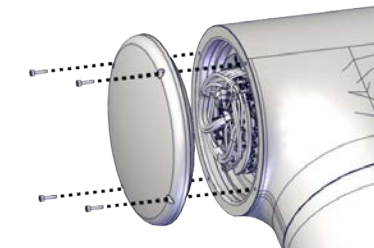
	Action	Note
1	Refit the insert.	<p>Insert: 3HAC084002-001 Hex socket head cap screw: M3x10 12.9 Lafre 2C2B/FC6.9 (3 pcs) Tightening torque: 1.4 Nm</p>  <p>xx2300000815</p>
2	Fit the o-ring to cover groove. Replace if damaged.	<p>O-ring: 3HAC061327-074 (for CRB 15000-10/1.52 and CRB 15000-12/1.27)</p>  <p>xx2300000816</p>
3	Refit the cover with the four screws.	<p>Hex socket head cap screw: M3x12 12.9 Lafre 2C2B/FC6.9 (4 pcs) Tightening torque: 1.4 Nm</p>  <p>xx2300000814</p>

Continues on next page

Concluding procedure

	Action	Note
1	<p>Calibrate the joint unit torque sensor.</p> <ol style="list-style-type: none"> 1 On the FlexPendant, go to the Code app and call the calibration procedure using PP to Routine, not by using Call Routine. 2 Select the Joint Unit Replacement feature and then select the axis to calibrate. 3 The controller is now restarted. Once the home screen of the FlexPendant is shown, press the Play button to continue the calibration routine. 4 The robot moves to a position or positions where measurements are performed. 5 The results of the measurements are presented together with the current values in the controller. Choose whether to save the calibration data or not. 6 If new calibration data is saved you will be asked to do a test with the lead-through functionality active to verify that the sensors work correctly. 7 Finally the robot is moved back to the original position. 8 Test the brake release (movement without drive power) functionality, see Testing the brake release functionality on page 196. 	See Calibration on page 1063
2	<p> DANGER</p> <p>Make sure all safety requirements are met when performing the first test run. See Test run after installation, maintenance, or repair on page 90.</p>	

5 Repair

5.6.3 Replacing the axis-2 joint unit (CRB 15000-5/0.95)

5.6.3 Replacing the axis-2 joint unit (CRB 15000-5/0.95)

Location of the axis-2 joint unit

The joint unit is located as shown in the figure.

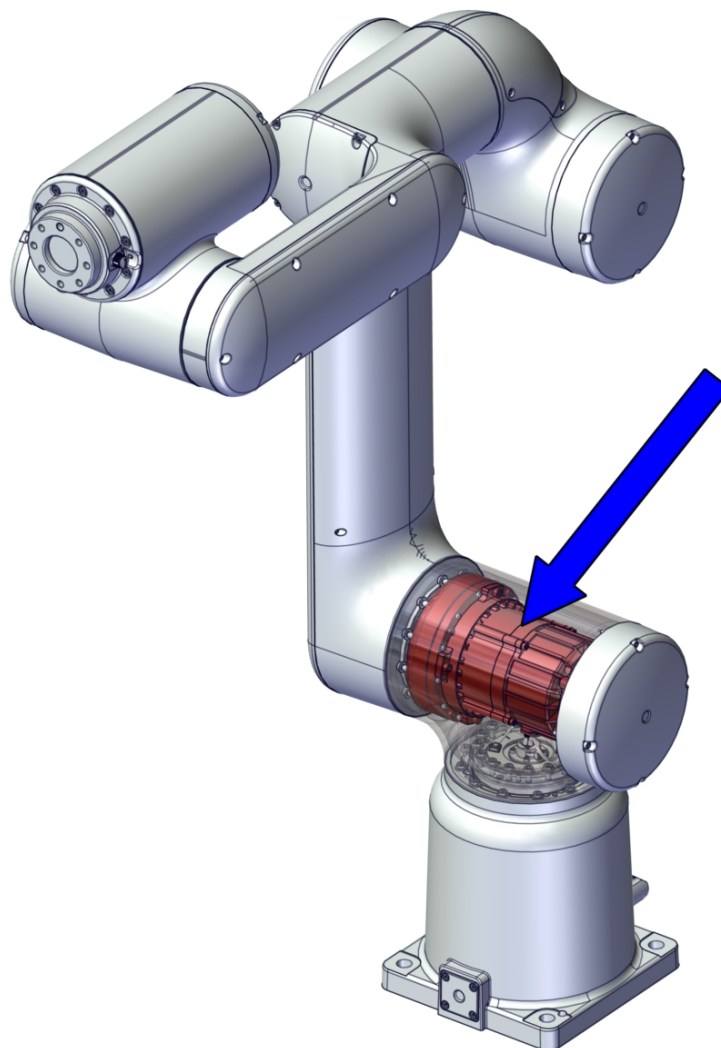

xx2000001948

Summary of the replacement procedure

This is a brief summary of the replacement procedure, containing the major actions to be performed.

- 1 Separate the cabling between the swing and the lower arm.
- 2 Remove the lower and upper arm undivided.
- 3 Remove the swing cover.
- 4 Replace the joint unit. Move the cabling from old to new joint unit.

Continues on next page

Required spare parts



Note

The spare part numbers that are listed in the table can be out of date. See the latest spare parts of the CRB 15000 via myABB Business Portal, www.abb.com/myABB.

Spare part	Article number	Note
Joint unit	3HAC079141-001	Used for CRB 15000-5/0.95. New attachment screws and cable tie 3HAC075545-001 are included in the delivery.

Required tools and equipment

Equipment	Article number	Note
Lifting aid	3HAC077788-001	For joint units on axes 1, 2 and 3 of CRB 15000-5/0.95. Attachment screws M4x35 (4 pcs) are enclosed.
Guide pin, M4x120	3HAC077786-001	Always use guide pins in pairs. For joint units on axes 1, 2 and 3 of CRB 15000-5/0.95 and axis 3 of CRB 15000-10/1.52 and CRB 15000-12/1.27.
Protection plate	3HAC077790-001	For protection of drive board during cabling installation on joint units of CRB 15000-5/0.95.
Cable tie gun EVO 7i	-	HellermannTyton 110-77001 or similar
Standard toolkit	-	Content is defined in section Standard toolkit on page 1099 .

Required consumables

Consumable	Article number	Note
Cleaning agent	-	Isopropanol
Flange sealant	-	Loctite 574
Cable ties	-	
O-ring	3HAC061327-047	Cover for axis 2/3, used for CRB 15000-5/0.95. Replace if damaged.
O-ring	3HAC061327-044	Lower arm, inner cover of CRB 15000-5/0.95. 1 pcs / cover. Replace if damaged.

Continues on next page

5 Repair



5.6.3 Replacing the axis-2 joint unit (CRB 15000-5/0.95)

Continued

Removing the joint unit

Use these procedures to remove the joint unit.

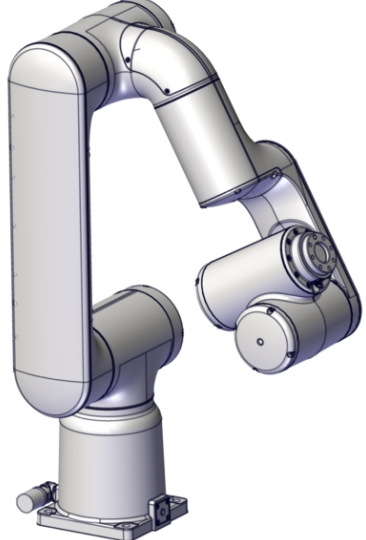
Preparations before removing the joint unit

	Action	Note
1	<p>Jog the robot to the specified position:</p> <ul style="list-style-type: none"> • Axis 1: 0° • Axis 2: 0° (home position) • Axis 3: +60° • Axis 4: 0° • Axis 5: -90° • Axis 6: No significance. <p> CAUTION</p> <p>Jog the axis on which the joint unit is to be replaced to home position, to achieve correct cable routing during replacement of the joint unit.</p>	 <p>xx2100000044</p>
2	<p> CAUTION</p> <p>Turn off all supplies for electrical power to the robot, before starting the repair work.</p>	

Removing the lower arm covers (-5/0.95)

	Action	Note
1	<p> CAUTION</p> <p>Make sure that all supplies for electrical power are turned off.</p>	

Continues on next page

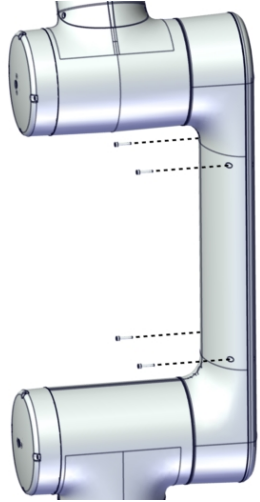
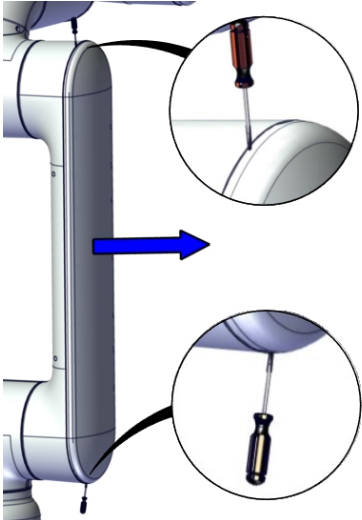
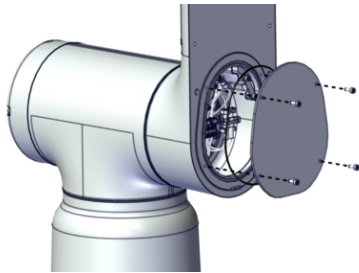
	Action	Note
2	Remove the four lower arm cover screws.	 <p>xx2000001929</p>
3	Remove the cover by inserting a small flat screwdriver to snap open the locks at each end of the cover.	 <p>xx2100000267</p>
4	Remove the inner cover by removing the four screws.	 <p>xx2000001930</p>

Continues on next page

5 Repair

5.6.3 Replacing the axis-2 joint unit (CRB 15000-5/0.95)

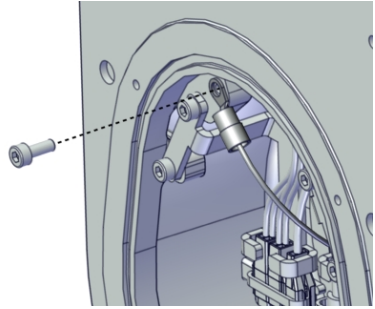
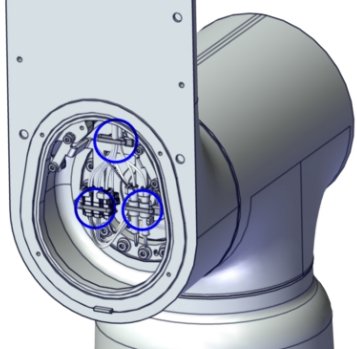
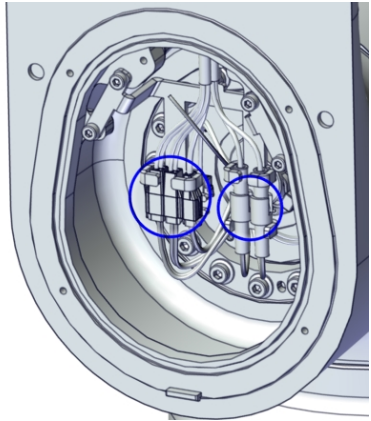

Continued

Disconnecting the cabling between the lower arm and the swing

	Action	Note
1	Remove the functional earth cable by removing the screw.	 xx2000001936
2	Cut the cable ties.	 xx2000001937
3	Snap loose and disconnect all connectors.	 xx2000001938

Continues on next page

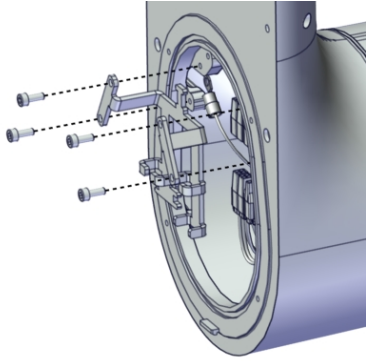
Removing the lower and upper arm assembled

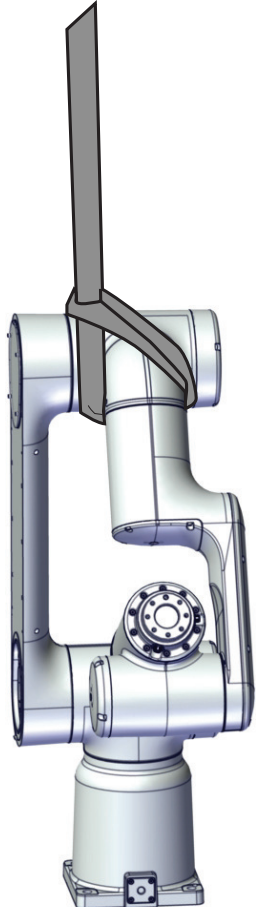

	Action	Note
1	Remove the cable bracket by removing the four screws.	 <p>xx200001939</p>
2	Secure the weight of the upper and lower arm.  CAUTION The weight of the complete upper and lower arm together is 18 kg	Suggestion with lifting sling and an overhead crane. Example of CRB 15000-5/0.95, similar to CRB 15000-10/1.52 and CRB 15000-12/1.27.  <p>xx210000294</p>

Continues on next page

5 Repair

5.6.3 Replacing the axis-2 joint unit (CRB 15000-5/0.95)

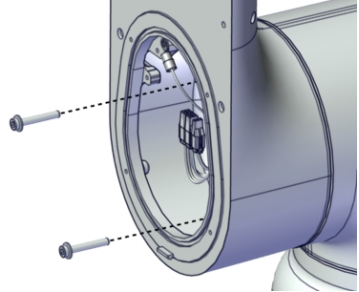
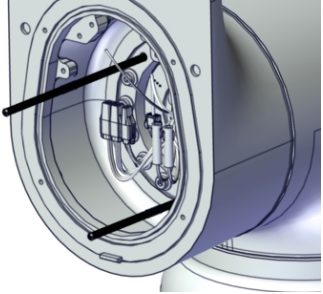
Continued

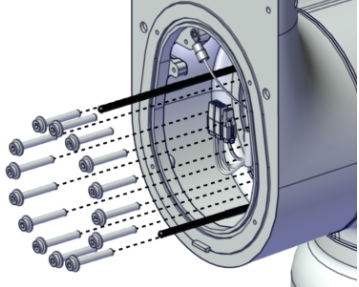
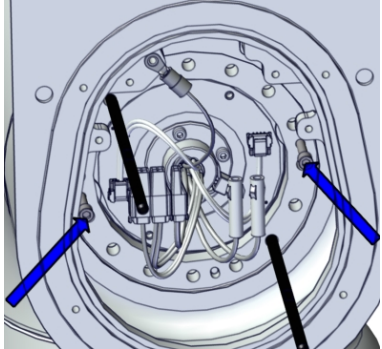
	Action	Note
3	<p>Remove two attachment screws and fit two guide pins to the axis-2 joint unit.</p> <p> CAUTION</p> <p>Do not mix the flange screws used for CRB 15000-5/0.95 and the threaded screws used for CRB 15000-10/1.52 and CRB 15000-12/1.27. Always use washers together with the threaded screws for CRB 15000-10/1.52 and CRB 15000-12/1.27. Illustration is for reference only.</p>	<p>Guide pin, M4x120: 3HAC077786-001</p> <p>Always use guide pins in pairs.</p>  <p>xx2000001951</p>  <p>xx2000001960</p>
4	<p>Remove the lower arm attachment screws.</p> <p> CAUTION</p> <p>Do not mix the flange screws used for CRB 15000-5/0.95 and the threaded screws used for CRB 15000-10/1.52 and CRB 15000-12/1.27. Always use washers together with the threaded screws for CRB 15000-10/1.52 and CRB 15000-12/1.27. Illustration is for reference only.</p>	 <p>xx2000001940</p>
5	<p>Use two fully threaded attachment screws as removal tools to press the lower arm out of position.</p>	 <p>xx2000002151</p>

Continues on next page

5.6.3 Replacing the axis-2 joint unit (CRB 15000-5/0.95)

Continued

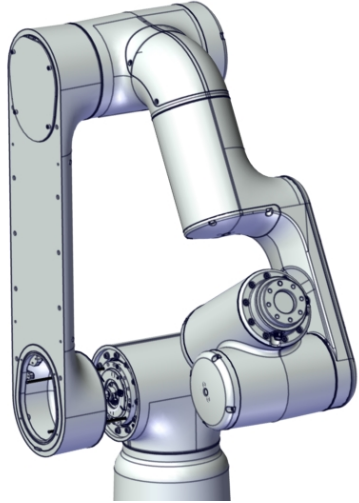
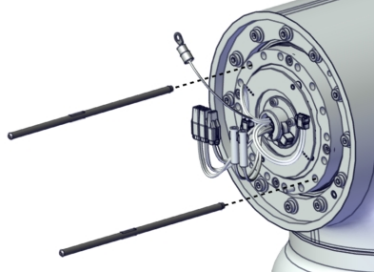
	Action	Note
6	Remove the complete arm system from the swing.	 <p>xx2000001941</p>
7	Remove the guide pins.	 <p>xx2000002432</p>

Removing the swing cover (-5/0.95)

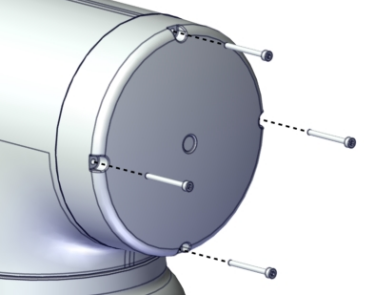
	Action	Note
1	 CAUTION Make sure that all supplies for electrical power are turned off.	
2	Remove the cover screws.	 <p>xx2000001935</p>

Continues on next page

5 Repair

5.6.3 Replacing the axis-2 joint unit (CRB 15000-5/0.95)

Continued

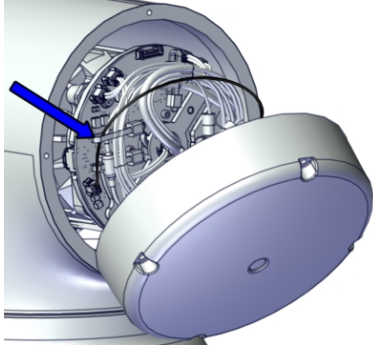
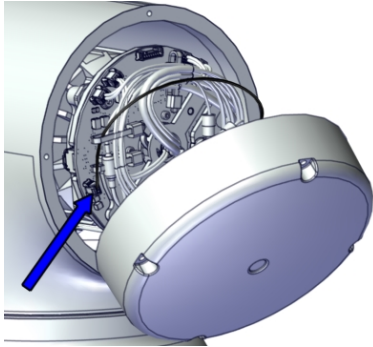
	Action	Note
3	 CAUTION Valid for CRB 15000-5/0.95 There is cabling connected between the cover and the joint unit drive board. Open the cover with care to avoid damage to the cabling or the connector(s). Do not leave the cover in location without being secured with the attachment screws.	
4	For robots with RobotWare earlier than 7.10 Open the cover and cut the cable tie that holds the brake release cable.	 xx2000001931
5	For robots with RobotWare earlier than 7.10 Disconnect the brake release connector DR.X8 from the drive board. Remove the cover.	 xx2000001932



Disconnecting the axis-2 joint unit cabling

	Action	Note
1	 ELECTROSTATIC DISCHARGE (ESD) The unit is sensitive to ESD. Before handling the unit read the safety information in section The unit is sensitive to ESD on page 53 .	

Continues on next page

5.6.3 Replacing the axis-2 joint unit (CRB 15000-5/0.95)

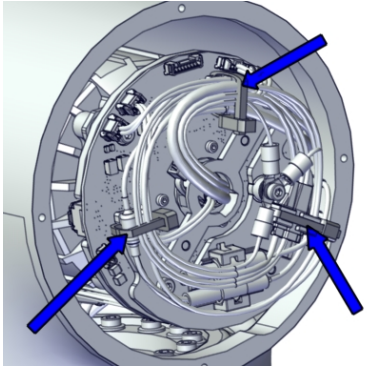
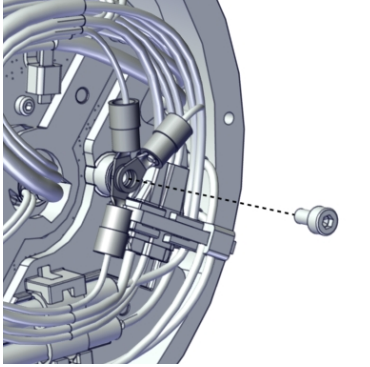
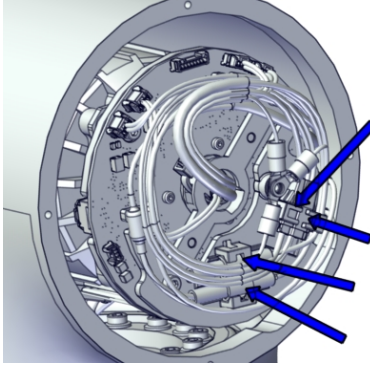
Continued

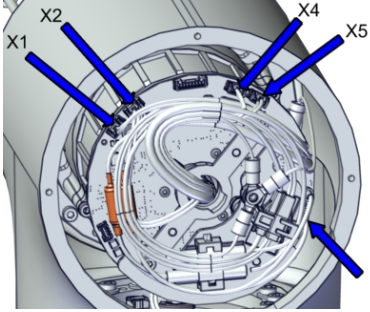
	Action	Note
2	Cut the cable ties.	 <p>xx2000001946</p>
3	Remove the functional and protective earth cables by removing the screw.	 <p>xx2000001945</p>
4	Snap loose and disconnect the connectors: <ul style="list-style-type: none"> • J2.DC+ • J2.DC- • J2.CS • J2.CP 	 <p>xx2000001944</p>
5	Disconnect the connectors from the drive board. <ul style="list-style-type: none"> • D2.X1 from X1 • D2.DC+ from DC+ • D2.DC- from ground • D2.X4 from X4 • D2.X2 from X2 • D2.X5 from X5 <p> CAUTION</p> <p>Use tweezers to unlock connectors and pull them off.</p>	 <p>xx2000002013</p>

Continues on next page

5 Repair

5.6.3 Replacing the axis-2 joint unit (CRB 15000-5/0.95)

Continued

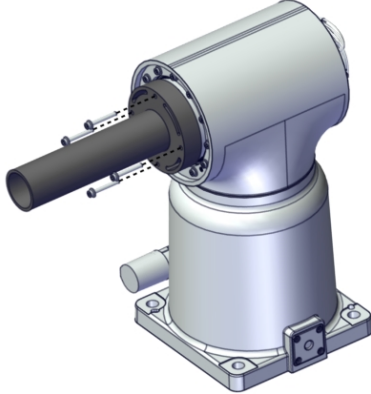
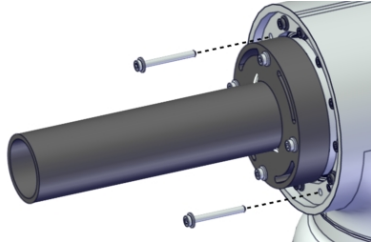
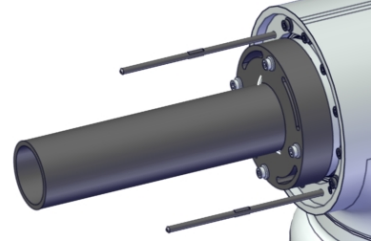
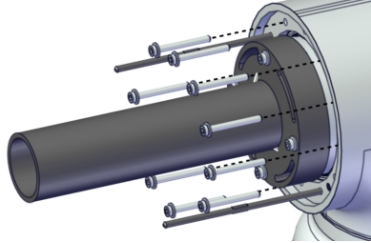

Removing the axis-2 joint unit (-5/0.95)

	Action	Note
1	<p>Fit the lifting aid to the joint unit, on the torque sensor side.</p> <p> CAUTION</p> <p>The connectors and the joint unit cables are sensitive to mechanical damage. Handle the assembly with care.</p>	<p>Lifting aid: 3HAC077788-001 Screws: M4x35 (4 pcs)</p>  <p>xx2000001956</p>
2	<p>Remove two attachment screws. Dispose the screws. New screws are included in the spare part delivery of the joint unit.</p>	 <p>xx2100000295</p>
3	<p>Fit two guide pins to the axis-2 joint unit.</p>	<p>Guide pin, M4x120: 3HAC077786-001 Always use guide pins in pairs. For joint units on axes 1, 2 and 3 of CRB 15000-5/0.95 and axis 3 of CRB 15000-10/1.52 and CRB 15000-12/1.27.</p>  <p>xx2000002433</p>
4	<p>Remove the remaining attachment screws. Use two screws as press out screws in the upcoming step, then dispose all screws. New screws are included in the spare part delivery of the joint unit.</p>	 <p>xx2000001943</p>

Continues on next page

5.6.3 Replacing the axis-2 joint unit (CRB 15000-5/0.95)

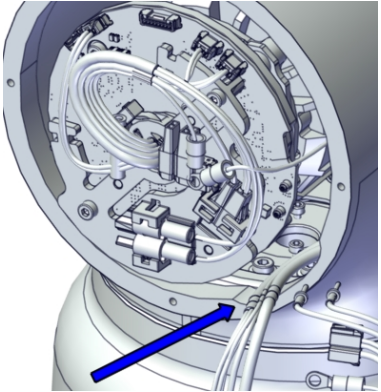
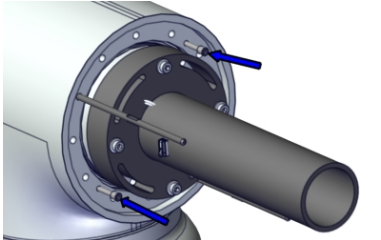
Continued

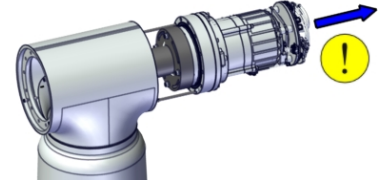
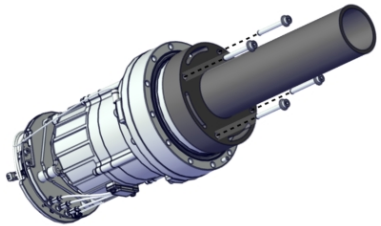
	Action	Note
5	Put the cabling at the slot in order not to squeeze it during removal of joint unit.	 <p>xx2100000045</p>
6	Press the joint unit out of position using two of the previous attachment screws as removal tools.	 <p>xx2000002434</p>
7	<p>Remove the joint unit from the swing.</p> <p> CAUTION</p> <p>The connectors and the joint unit cables are sensitive to mechanical damage. Handle the assembly with care.</p>	 <p>xx2000001958</p>
8	Remove the lifting aid and guide pins.	 <p>xx2000001957</p>

Removing the joint cable

	Action	Note
1	<p> ELECTROSTATIC DISCHARGE (ESD)</p> <p>The unit is sensitive to ESD. Before handling the unit read the safety information in section The unit is sensitive to ESD on page 53.</p>	

Continues on next page



5 Repair

5.6.3 Replacing the axis-2 joint unit (CRB 15000-5/0.95)

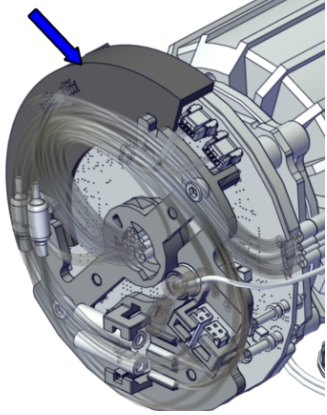
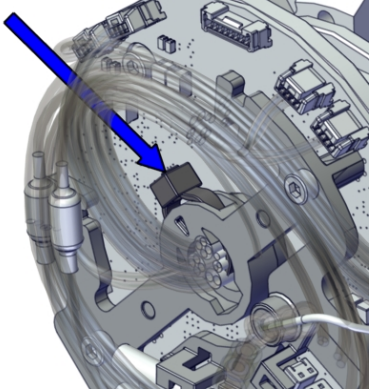
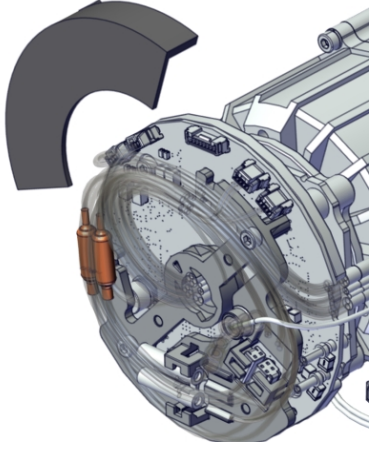
Continued

	Action	Note
2	<p>Fit the protection plate to the drive board unit.</p> <p> Tip</p> <p>Using the protection plate is important for protecting the drive board unit. If complete joint unit is to be replaced, the protection plate is not needed.</p>	<p>Protection plate: 3HAC077790-001 (for CRB 15000-5/0.95) / 3HAC087789-001 (for CRB 15000-10/1.52 and CRB 15000-12/1.27)</p>  <p>xx2000002057</p>
3	<p>Cut the cable tie at the drive board.</p>	 <p>xx2000002058</p>
4	<p>Remove the protection plate.</p>	 <p>xx2100000301</p>

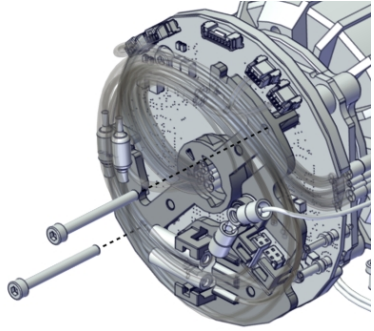
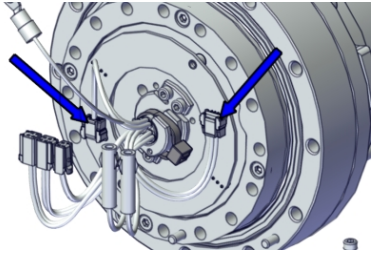
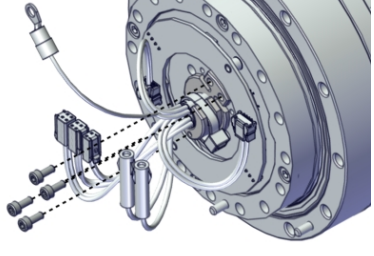
Continues on next page

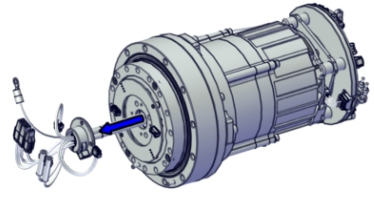
	Action	Note
5	Remove the cable support from the drive board by removing the attachment screws.	 <p>xx2000002055</p>
6	Disconnect the two connectors from the torque sensor board. <ul style="list-style-type: none"> • TQ.A • TQ.B 	 <p>xx2000002053</p>
7	Remove the cable plate by removing the attachment screws.	 <p>xx2000002049</p>
8	Remove the joint cable from the hollow shaft from the torque sensor side. <p> CAUTION</p> The connectors and the joint unit cables are sensitive to mechanical damage. Handle the assembly with care.	 <p>xx2000002060</p>

Refitting the joint unit

Use these procedures to refit the joint unit.

Refitting the joint cable

	Action	Note
1	 ELECTROSTATIC DISCHARGE (ESD) <p>The unit is sensitive to ESD. Before handling the unit read the safety information in section The unit is sensitive to ESD on page 53.</p>	

Continues on next page

5 Repair

5.6.3 Replacing the axis-2 joint unit (CRB 15000-5/0.95)

Continued

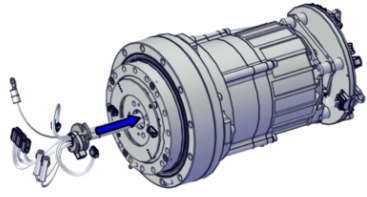
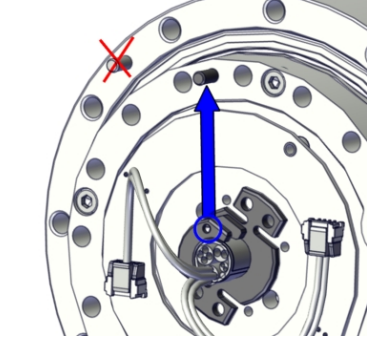
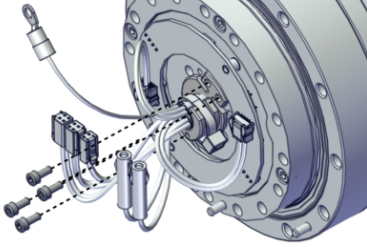
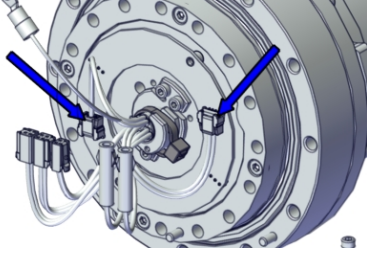
	Action	Note
2	<p>Place the joint cable through the hollow shaft from the torque sensor side.</p> <p> CAUTION</p> <p>The connectors and the joint unit cables are sensitive to mechanical damage. Handle the assembly with care.</p>	 <p>xx2000002048</p>
3	<p>Orient the cable plate according to the figure. The circle on the cable plate should point towards the guide pin on the torque sensor.</p>	 <p>xx2000002051</p>
4	<p>Secure the cable plate to the joint unit with the attachment screws.</p>	<p>Hex socket head cap screw: M2.5x6 12.9 Lafre 2C2B/FC6.9 (4 pcs)</p> <p>Tightening torque: 0.45 Nm.</p>  <p>xx2000002049</p>
5	<p>Connect the two connectors to the torque sensor board.</p> <ul style="list-style-type: none"> • TQ.A to CH1/A • TQ.B to CH2/B 	 <p>xx2000002053</p>

Continues on next page

5.6.3 Replacing the axis-2 joint unit (CRB 15000-5/0.95)

Continued

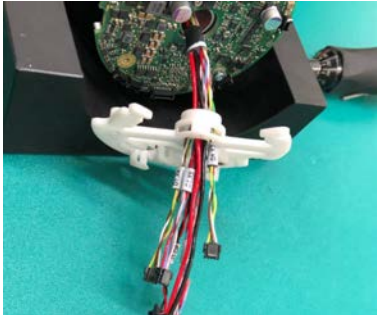
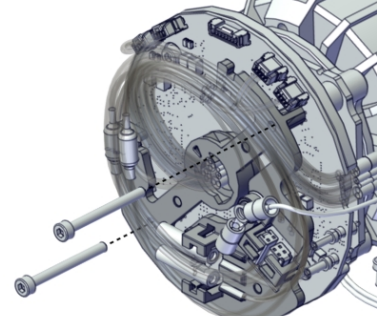
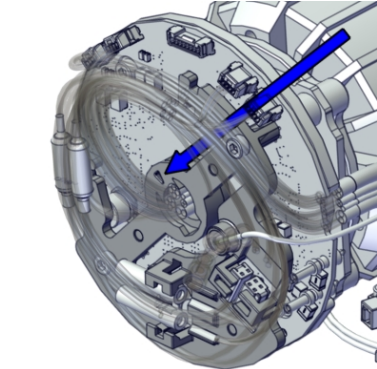

	Action	Note
6	<p>Insert the cabling through the cable support and fit the support to the drive board with the attachment screws.</p>	 <p>xx2000002056</p> <p>Hex socket head cap screw: M3x30 12.9 Lafre 2C2B/FC6.9 (2 pcs) Tightening torque: 0.45 Nm.</p>  <p>xx2000002055</p>
7	<p>Keep the cabling loose, making sure not to twist or strain it. Use the cable tie to pre-fix the cable by hand.</p>	 <p>xx2100000507</p>

Continues on next page

5 Repair

5.6.3 Replacing the axis-2 joint unit (CRB 15000-5/0.95)

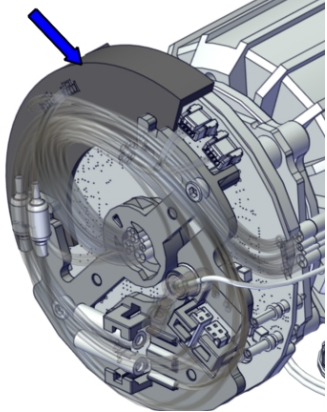
Continued

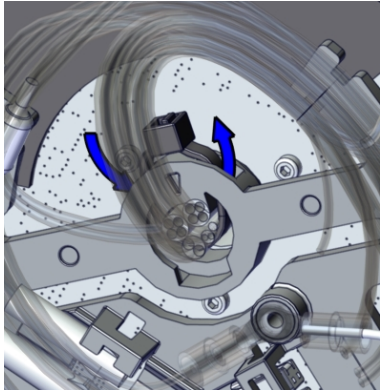
	Action	Note
8	Fit the protection plate to the drive board unit.	<p>Protection plate: 3HAC077790-001 (for CRB 15000-5/0.95) / 3HAC087789-001 (for CRB 15000-10/1.52 and CRB 15000-12/1.27)</p>  <p>xx2000002057</p>
9	Secure the cables to the cable support with a cable tie, using a cable tie gun. Assembly direction for the cable tie is shown in the figure.	<p>Cable tie: 3HAC075545-001. For securing joint unit cable. Cable tie gun EVO 7i Settiing for cable tie gun: 6.75.</p>  <p>xx2000002058</p>  <p>xx2000002059</p>



Continues on next page

5.6.3 Replacing the axis-2 joint unit (CRB 15000-5/0.95)

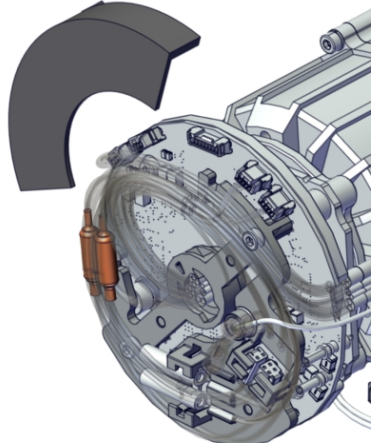
Continued

	Action	Note
10	Remove the protection plate.	 <p>xx2100000301</p>

Preparations before fitting the joint unit (-5/0.95)

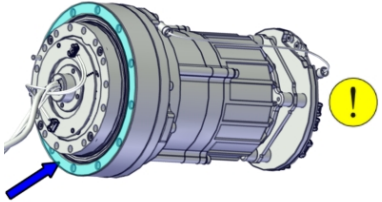
	Action	Note
1	 <p>ELECTROSTATIC DISCHARGE (ESD)</p> <p>The unit is sensitive to ESD. Before handling the unit read the safety information in section The unit is sensitive to ESD on page 53.</p>	
2	<p>Clean the mounting surface of the joint unit and the mating surface on the casting with isopropanol.</p> <p>Joint unit mounting surface is pointed out in the figure.</p>	<p>Cleaning agent: Isopropanol Flange sealant: Loctite 574</p>
3	<p>Apply a thin layer of flange sealant to the mounting surface. Do not contaminate the radial sealing with sealant.</p> <p> CAUTION</p> <p>The connectors and the joint unit cables are sensitive to mechanical damage. Handle the assembly with care.</p> <p> ELECTROSTATIC DISCHARGE (ESD)</p> <p>The unit is sensitive to ESD. Before handling the unit read the safety information in section The unit is sensitive to ESD on page 53.</p>	 <p>xx2000001860</p>





Continues on next page

5 Repair

5.6.3 Replacing the axis-2 joint unit (CRB 15000-5/0.95)

Continued

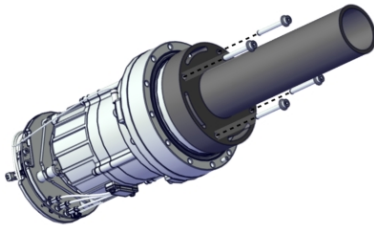
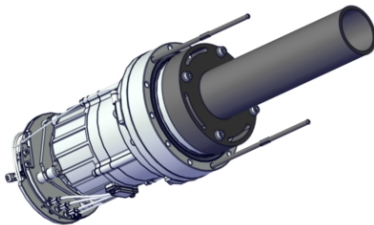
Refitting the axis-2 joint unit (-5/0.95)

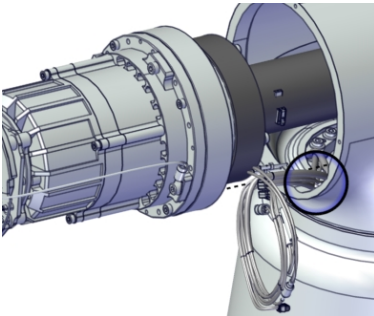
	Action	Note
1	 ELECTROSTATIC DISCHARGE (ESD) The unit is sensitive to ESD. Before handling the unit read the safety information in section <i>The unit is sensitive to ESD on page 53.</i>	
2	Fit the lifting aid to the joint unit.  CAUTION The connectors and the joint unit cables are sensitive to mechanical damage. Handle the assembly with care.	Joint unit: 3HAC079141-001 Lifting aid: 3HAC077788-001 Screws: M4x35 (4 pcs)  <small>xx2000001957</small>
3	Fit two guide pins to the joint unit.	Guide pin, M4x120: 3HAC077786-001 Always use guide pins in pairs. For joint units on axes 1, 2 and 3 of CRB 15000-5/0.95 and axis 3 of CRB 15000-10/1.52 and CRB 15000-12/1.27.  <small>xx2000002438</small>
4	Place the axis-1 cabling at the notch in the swing.  CAUTION The cabling is sensitive to mechanical damage. Handle it with care to avoid damage to the cabling or the connector, avoid any kind of tilt or skew.	 <small>xx2000002153</small>

Continues on next page

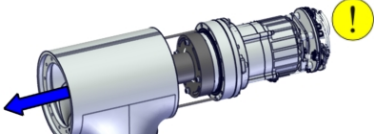
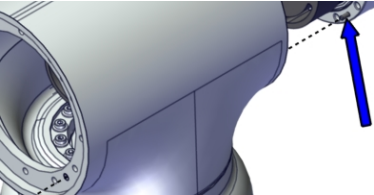
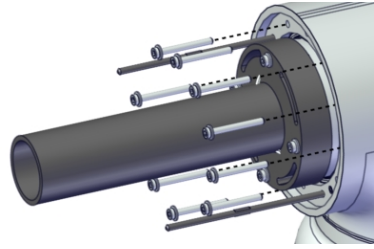
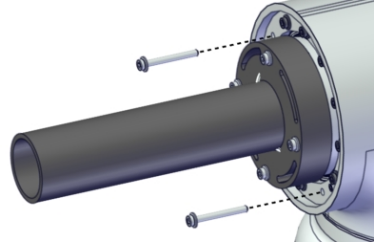
	Action	Note
5	<p>Fit the joint unit to the swing, aligning the pin with the pin hole.</p> <p> CAUTION</p> <p>The connectors and the joint unit cables are sensitive to mechanical damage. Handle the assembly with care.</p>	 <p>xx2000001959</p>  <p>xx2000001961</p>
6	<p>Secure the joint unit with new attachment screws.</p>	<p>Flange socket head screw with glue: 3HAB3413-435</p> <p>M4x35 12.9 Lafre 2C2B/FC6.9+PrO-COat111, with NYPLAS glue , 12 pcs</p> <p>Used for joint unit of CRB 15000-5/0.95.</p> <p>Always use new screws when refitting a joint unit. If ordering a new joint unit spare part, new screws are included.</p>  <p>xx2000001943</p>
7	<p>Remove the guide pins and secure the remaining two attachment screws.</p>	 <p>xx2100000295</p>
8	<p>Pre-tighten the screws crosswise.</p>	
9	<p>Torque tighten all screws crosswise.</p>	<p>Tightening torque: 4.3 Nm.</p>

Continues on next page

5 Repair

5.6.3 Replacing the axis-2 joint unit (CRB 15000-5/0.95)

Continued

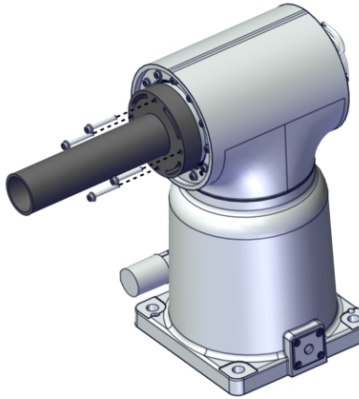
	Action	Note
10	Remove the lifting aid by removing the screws.	 <p data-bbox="1034 719 1136 741">xx2000001956</p>
11	Clean pushed-out flange sealant, if any.	

Connecting the axis-2 joint unit cabling

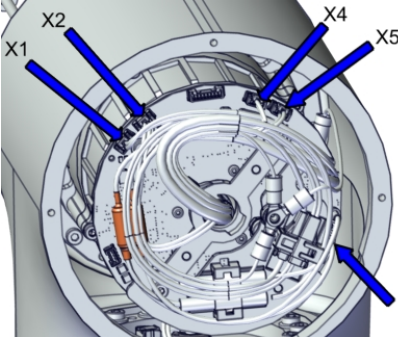
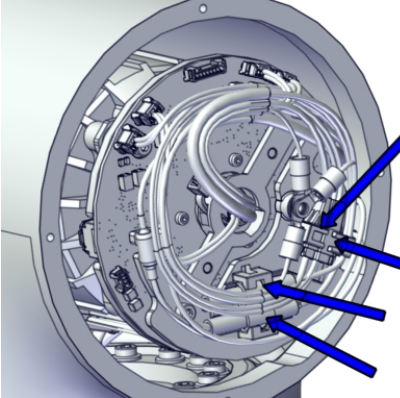
	Action	Note
1	 <p data-bbox="568 969 987 1003">ELECTROSTATIC DISCHARGE (ESD)</p> <p data-bbox="483 1032 987 1115">The unit is sensitive to ESD. Before handling the unit read the safety information in section The unit is sensitive to ESD on page 53.</p>	
2	<p data-bbox="483 1149 987 1182">Reconnect the connectors to the drive board.</p> <ul data-bbox="512 1182 751 1368" style="list-style-type: none"> • D2.X1 to X1 • D2.DC+ to DC+ • D2.DC- to Ground • D2.X4 to X4 • D2.X2 to X2 • D2.X5 to X5 	 <p data-bbox="995 1491 1102 1514">xx2000002013</p>
3	<p data-bbox="483 1547 987 1603">Connect the connectors to each other and snap them to the cable holders.</p> <ul data-bbox="512 1603 751 1727" style="list-style-type: none"> • J2.DC+ to J2.DC+ • J2.DC- to J2.DC- • J2.CS to J2.CS • J2.CP to J2.CP 	 <p data-bbox="995 1951 1102 1973">xx2000001944</p>

Continues on next page

5.6.3 Replacing the axis-2 joint unit (CRB 15000-5/0.95)

Continued

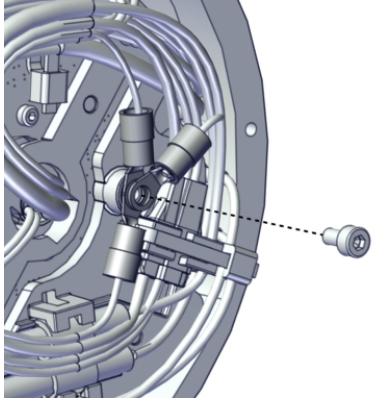
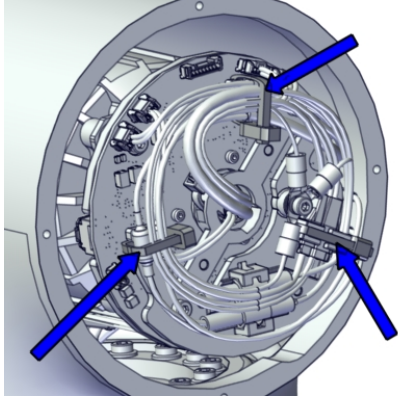
	Action	Note
4	Secure the cables for functional earth and protective earth with a screw.	<p>Hex socket head cap screw: M3x6 (1 pcs). Tightening torque: 0.8 Nm.</p>  <p>xx2000001945</p>
5	Secure the cabling with cable ties.	<p>Cable ties (3 pcs)</p>  <p>xx2000001946</p>

Refitting the swing cover(-5/0.95)

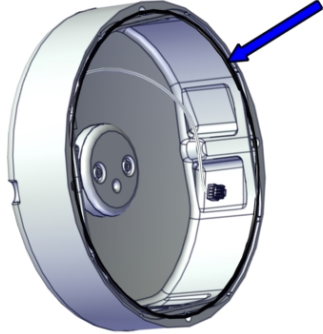
	Action	Note
1	Fit the o-ring to cover groove. Replace if damaged.	<p>O-ring: 3HAC061327-047 (for CRB 15000-5/0.95)</p>  <p>xx2000001962</p>

Continues on next page

5 Repair

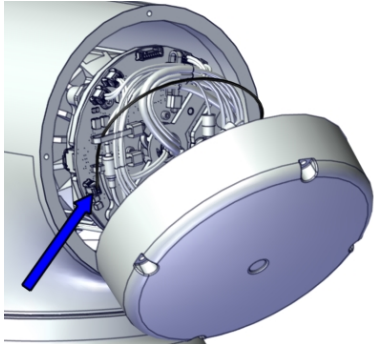
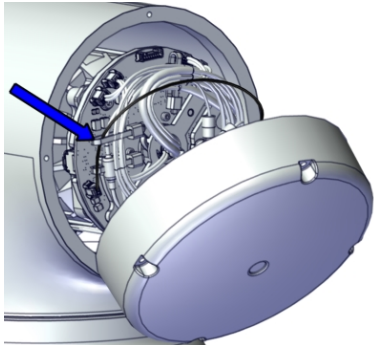
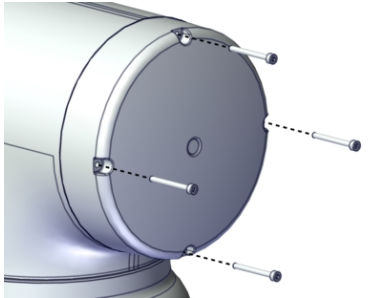

5.6.3 Replacing the axis-2 joint unit (CRB 15000-5/0.95)

Continued

	Action	Note
2	<p>For robots with RobotWare earlier than 7.10</p> <p>Place the cover at mounting position and reconnect the brake release connector DR.X8 to the drive board.</p> <p>Orient the cover for proper arrangement of the brake release cable.</p>	 <p>xx2000001932</p>
3	<p>For robots with RobotWare earlier than 7.10</p> <p>Secure the brake release cable with a cable tie.</p>	<p>Cable ties</p>  <p>xx2000001931</p>
4	<p>Refit the cover with the four screws.</p>	<p>Hex socket head cap screw: M3x30 12.9 Lafre 2C2B/FC6.9 (4 pcs) Tightening torque: 0.45 Nm</p>  <p>xx2000001935</p>

Continues on next page

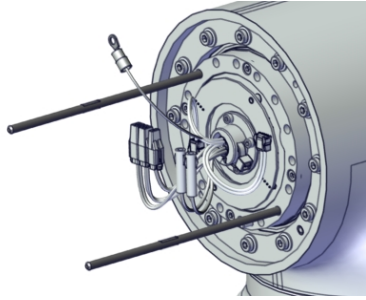
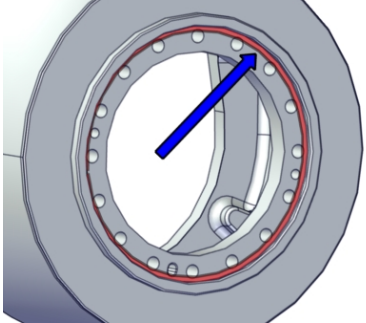
Refitting the lower and upper arm assembled (-5/0.95)

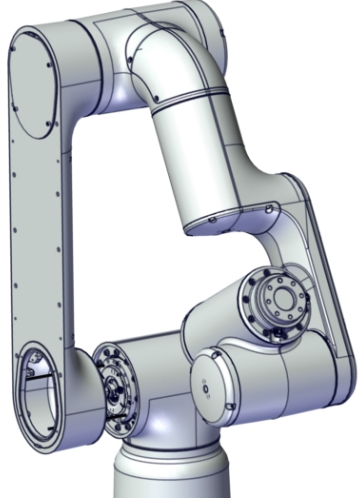
	Action	Note
1	Fit two guide pins to the axis-2 joint unit.	<p>Guide pin, M4x120: 3HAC077786-001</p>  <p>xx2000001949</p>
2	<p>Remove any old residuals of flange sealant from the lower arm mounting surface and clean with isopropanol.</p> <p>Apply new flange sealant to the corner of the lower arm mounting surface, as pointed out in the figure.</p>	<p>Cleaning agent: Isopropanol Flange sealant: Loctite 574</p>  <p>xx2000001963</p>
3	<p> CAUTION</p> <p>The weight of the complete upper and lower arm together is 18 kg</p>	
4	Lift the upper and lower arm assembly to mounting position and slide it onto the guide pins.	 <p>xx2000001941</p>

Continues on next page

5 Repair

5.6.3 Replacing the axis-2 joint unit (CRB 15000-5/0.95)

Continued

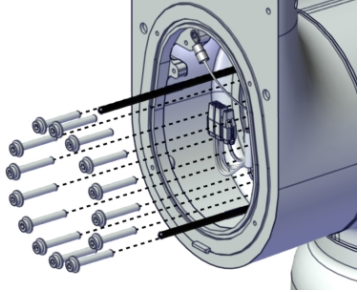
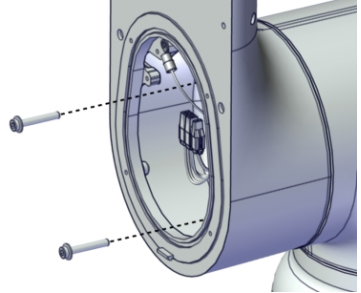
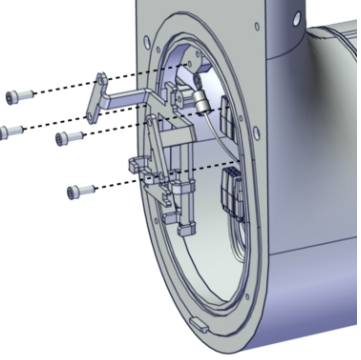
	Action	Note
5	<p>Secure the lower arm to the swing with all attachment screws but two. Pre-tighten the screws crosswise firstly.</p> <p>! CAUTION</p> <p>Do not mix the flange screws used for CRB 15000-5/0.95 and the threaded screws used for CRB 15000-10/1.52 and CRB 15000-12/1.27. Always use washers together with the threaded screws for CRB 15000-10/1.52 and CRB 15000-12/1.27. Illustration is for reference only.</p>	<p>Hex socket head cap flange screw: M4x25 12.9 Lafre 2C2B/FC6.9+PrO-COat111 (16 pcs)</p>  <p>xx2000001940</p>
6	<p>Remove the guide pins and fasten the remaining two screws.</p> <p>! CAUTION</p> <p>Do not mix the flange screws used for CRB 15000-5/0.95 and the threaded screws used for CRB 15000-10/1.52 and CRB 15000-12/1.27. Always use washers together with the threaded screws for CRB 15000-10/1.52 and CRB 15000-12/1.27. Illustration is for reference only.</p>	<p>Hex socket head cap flange screw: M4x25 12.9 Lafre 2C2B/FC6.9+PrO-COat111 (16 pcs)</p>  <p>xx2000001951</p>
7	Torque tighten all screws crosswise.	Tightening torque: 4.6 Nm
8	Refit the cable bracket with four screws.	<p>Hex socket head cap screw: M3x8 12.9 Lafre 2C2B/FC6.9 (4 pcs). Tightening torque: 0.8 Nm</p>  <p>xx2000001939</p>

Continues on next page

Connecting the cabling between the lower arm and swing

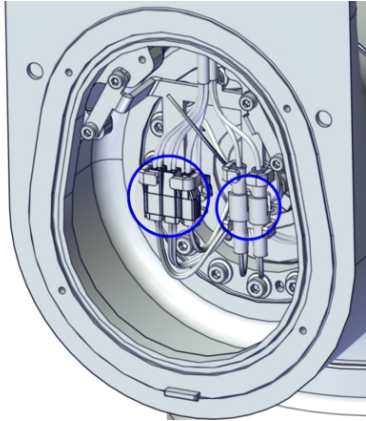
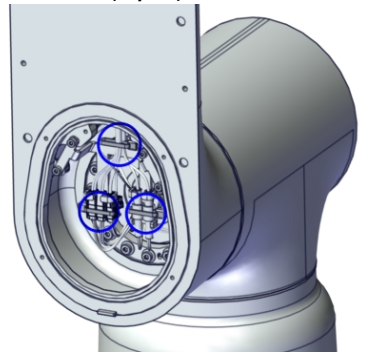
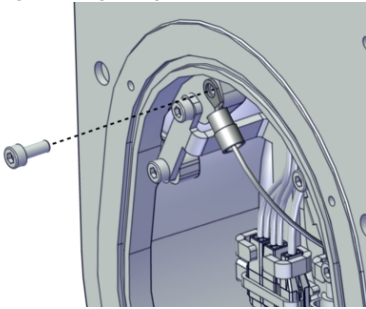
	Action	Note
1	Connect the connectors to each other and snap them to the cable holders.	 <p>xx2000001938</p>
2	Secure the cabling with cable ties.	<p>Cable ties (3 pcs)</p>  <p>xx2000001937</p>
3	Connect the functional earth cable with the screw.	<p>Hex socket head cap screw: M3x8 12.9 Lafre 2C2B/FC6.9 (1 pcs). Tightening torque: 0.8 Nm</p>  <p>xx2000001936</p>

Continues on next page

5 Repair

5.6.3 Replacing the axis-2 joint unit (CRB 15000-5/0.95)

Continued

Refitting the lower arm covers (-5/0.95)

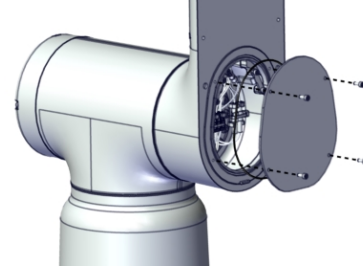
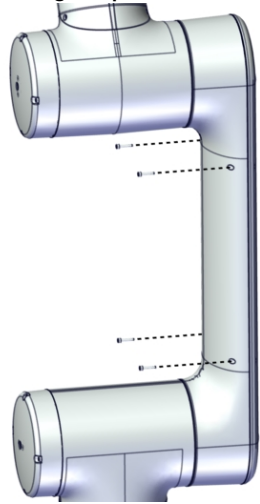
	Action	Note
1	Wipe, lubricate and fit the o-ring to its groove. Replace if damaged.	<p>O-ring: 3HAC061327-044 Grease: 3HAC042536-001 (Shell Gadus S2)</p>  <p>xx2000001954</p>
2	Refit the inner cover with four screws.	<p>Hex socket head cap screw: M3x8 12.9 Lafre 2C2B/FC6.9 (4 pcs) Tightening torque: 1.4 Nm.</p>  <p>xx2000001930</p>
3	Snap the lower arm cover into place.	<p>Hex socket head cap screw: M3x16 12.9 Lafre 2C2B/FC6.9 (4 pcs) Tightening torque: 0.45 Nm.</p>  <p>xx2000001929</p>
4	Secure the cover with four screws.	

Continues on next page

Concluding procedure

	Action	Note
1	<p>Calibrate the joint unit torque sensor.</p> <ol style="list-style-type: none"> 1 On the FlexPendant, go to the Code app and call the calibration procedure using PP to Routine, not by using Call Routine. 2 Select the Joint Unit Replacement feature and then select the axis to calibrate. 3 The controller is now restarted. Once the home screen of the FlexPendant is shown, press the Play button to continue the calibration routine. 4 The robot moves to a position or positions where measurements are performed. 5 The results of the measurements are presented together with the current values in the controller. Choose whether to save the calibration data or not. 6 If new calibration data is saved you will be asked to do a test with the lead-through functionality active to verify that the sensors work correctly. 7 Finally the robot is moved back to the original position. 8 Test the brake release (movement without drive power) functionality, see Testing the brake release functionality on page 196. 	See Calibration on page 1063
2	<p> DANGER</p> <p>Make sure all safety requirements are met when performing the first test run. See Test run after installation, maintenance, or repair on page 90.</p>	

5 Repair

5.6.4 Replacing the axis-2 joint unit (CRB 15000-10/1.52 and CRB 15000-12/1.27)

5.6.4 Replacing the axis-2 joint unit (CRB 15000-10/1.52 and CRB 15000-12/1.27)

Location of the axis-2 joint unit

The joint unit is located as shown in the figure.

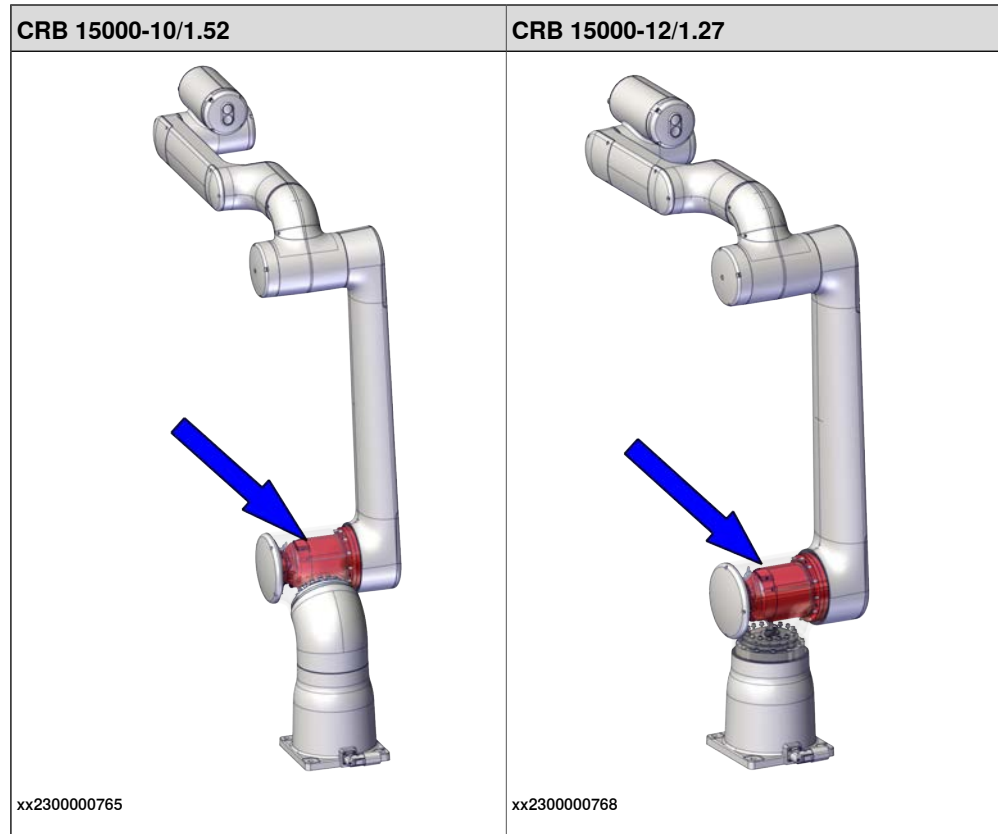

Summary of the replacement procedure

This is a brief summary of the replacement procedure, containing the major actions to be performed.

- 1 Separate the cabling between the swing and the lower arm.
- 2 Remove the lower and upper arm undivided.
- 3 Remove the swing cover.
- 4 Loosen the base from the foundation and lay it down with the torque sensor side upwards.
- 5 Replace the joint unit. Move the cabling from old to new joint unit.

Required spare parts



Note

The spare part numbers that are listed in the table can be out of date. See the latest spare parts of the CRB 15000 via myABB Business Portal, www.abb.com/myABB.

Continues on next page

5.6.4 Replacing the axis-2 joint unit (CRB 15000-10/1.52 and CRB 15000-12/1.27)

Continued

Spare part	Article number	Note
Joint unit	3HAC087472-001	Used for CRB 15000-10/1.52 and CRB 15000-12/1.27. New O-rings 3HAC061327-044 and cable tie 3HAC075545-001 are included in the delivery.

Required tools and equipment

Equipment	Article number	Note
Lifting aid	3HAC087787-001	For joint units on axes 1 and 2 of CRB 15000-10/1.52 and CRB 15000-12/1.27. A plate, a beam, a pair of semicircular blocks and attachment screws M5x30 (2 pcs) are enclosed.
Guide pin, M5x125	3HAC087786-001	Always use guide pins in pairs. For joint units on axes 1 and 2 of CRB 15000-10/1.52 and CRB 15000-12/1.27.
Protection plate	3HAC087789-001	For protection of drive board during cabling installation on joint units of CRB 15000-10/1.52 and CRB 15000-12/1.27.
Cable tie gun EVO 7i	-	HellermannTyton 110-77001 or similar
Standard toolkit	-	Content is defined in section Standard toolkit on page 1099 .

Required consumables

Consumable	Article number	Note
Cable ties	-	
O-ring	3HAC061327-044	Axis-1 and -2 joint unit, used for CRB 15000-10/1.52 and CRB 15000-12/1.27. Replace if damaged.
O-ring	3HAC061327-074	Swing cover, used for CRB 15000-10/1.52 and CRB 15000-12/1.27. Replace if damaged.
O-ring	3HAC061327-075	Lower arm, lower inner cover of CRB 15000-10/1.52 and CRB 15000-12/1.27. Replace if damaged.

Continues on next page

5 Repair



5.6.4 Replacing the axis-2 joint unit (CRB 15000-10/1.52 and CRB 15000-12/1.27)

Continued

Removing the joint unit

Use these procedures to remove the joint unit.

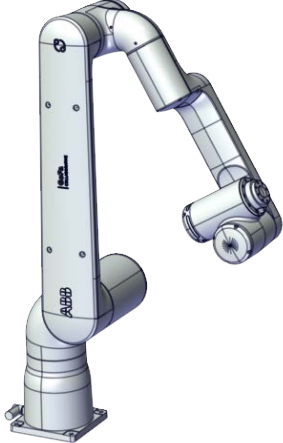
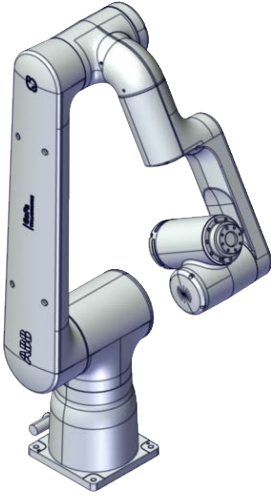
Preparations before removing the joint unit

	Action	Note
1	<p>Jog the robot to the specified position:</p> <ul style="list-style-type: none"> • Axis 1: 0° • Axis 2: 0° (home position) • Axis 3: +60° • Axis 4: 0° • Axis 5: -90° • Axis 6: No significance. <p> CAUTION</p> <p>Jog the axis on which the joint unit is to be replaced to home position, to achieve correct cable routing during replacement of the joint unit.</p>	<p>Valid for CRB 15000-10/1.52</p>  <p>xx2300001062</p> <p>Valid for CRB 15000-12/1.27</p>  <p>xx2300001063</p>
2	<p> CAUTION</p> <p>Turn off all supplies for electrical power to the robot, before starting the repair work.</p>	

Continues on next page

5.6.4 Replacing the axis-2 joint unit (CRB 15000-10/1.52 and CRB 15000-12/1.27)

Continued

Removing the lower arm covers (-10/1.52 and -12/1.27)

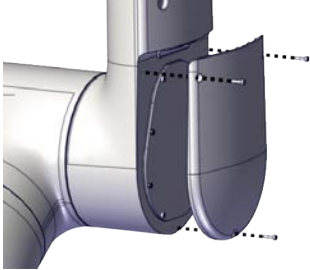
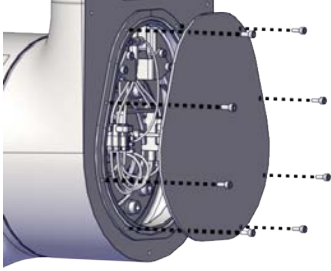
	Action	Note
1	 CAUTION Make sure that all supplies for electrical power are turned off.	
2	Remove the lower cover of lower arm by removing the screws.	 <p>xx2300000812</p>
3	Remove the lower inner cover by removing the screws.	 <p>xx2300000813</p>

Disconnecting the cabling between the lower arm and the swing

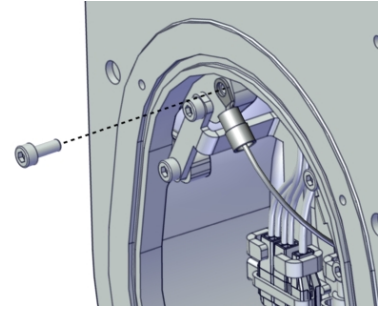
	Action	Note
1	Remove the functional earth cable by removing the screw.	 <p>xx2000001936</p>

Continues on next page

5 Repair

5.6.4 Replacing the axis-2 joint unit (CRB 15000-10/1.52 and CRB 15000-12/1.27)

Continued

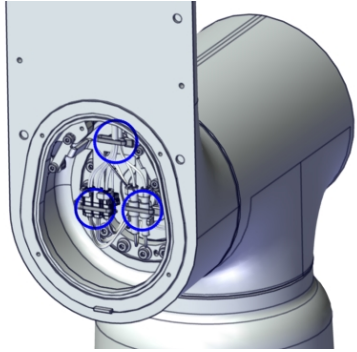
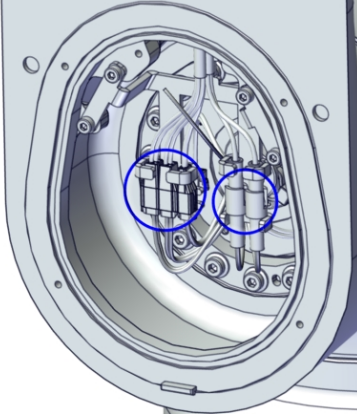
	Action	Note
2	Cut the cable ties.	 xx2000001937
3	Snap loose and disconnect all connectors.	 xx2000001938

Removing the lower and upper arm assembled

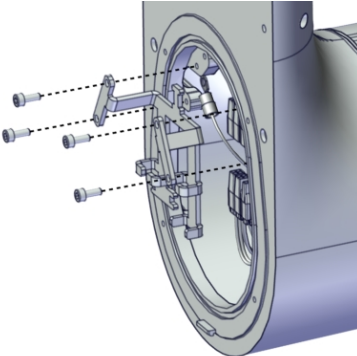
	Action	Note
1	Remove the cable bracket by removing the four screws.	 xx2000001939

Continues on next page

5.6.4 Replacing the axis-2 joint unit (CRB 15000-10/1.52 and CRB 15000-12/1.27)

Continued

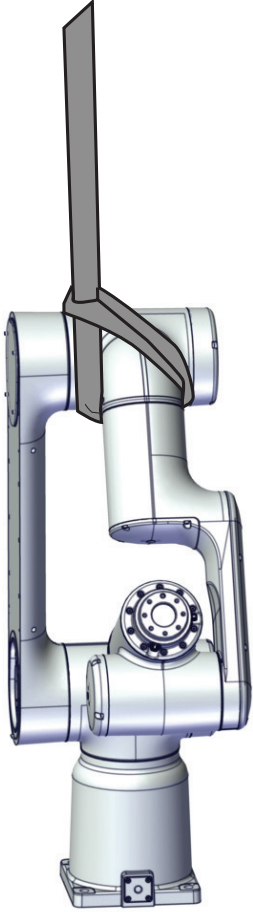

	Action	Note
2	<p>Secure the weight of the upper and lower arm.</p> <p> CAUTION</p> <p>The weight of the complete upper and lower arm together is up to 26 kg</p>	<p>Suggestion with lifting sling and an overhead crane.</p> <p>Example of CRB 15000-5/0.95, similar to CRB 15000-10/1.52 and CRB 15000-12/1.27.</p>  <p>xx210000294</p>

Continues on next page

5 Repair

5.6.4 Replacing the axis-2 joint unit (CRB 15000-10/1.52 and CRB 15000-12/1.27)

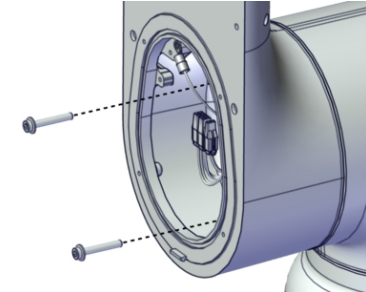
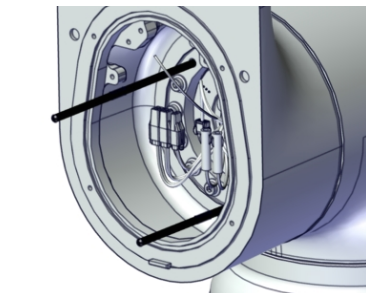
Continued

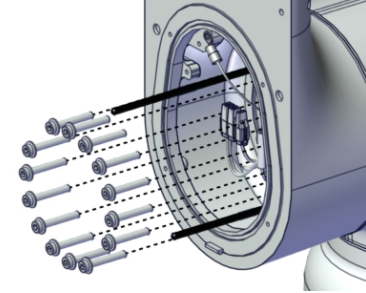
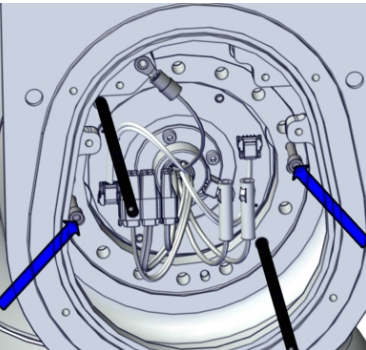
	Action	Note
3	<p>Remove two attachment screws and fit two guide pins to the axis-2 joint unit.</p> <p> CAUTION</p> <p>Do not mix the flange screws used for CRB 15000-5/0.95 and the threaded screws used for CRB 15000-10/1.52 and CRB 15000-12/1.27. Always use washers together with the threaded screws for CRB 15000-10/1.52 and CRB 15000-12/1.27. Illustration is for reference only.</p>	<p>Guide pin, M5x125: 3HAC087786-001</p> <p>Always use guide pins in pairs.</p>  <p>xx2000001951</p>  <p>xx2000001960</p>
4	<p>Remove the lower arm attachment screws.</p> <p> CAUTION</p> <p>Do not mix the flange screws used for CRB 15000-5/0.95 and the threaded screws used for CRB 15000-10/1.52 and CRB 15000-12/1.27. Always use washers together with the threaded screws for CRB 15000-10/1.52 and CRB 15000-12/1.27. Illustration is for reference only.</p>	 <p>xx2000001940</p>
5	<p>Use two fully threaded attachment screws as removal tools to press the lower arm out of position.</p>	 <p>xx2000002151</p>

Continues on next page

5.6.4 Replacing the axis-2 joint unit (CRB 15000-10/1.52 and CRB 15000-12/1.27)

Continued

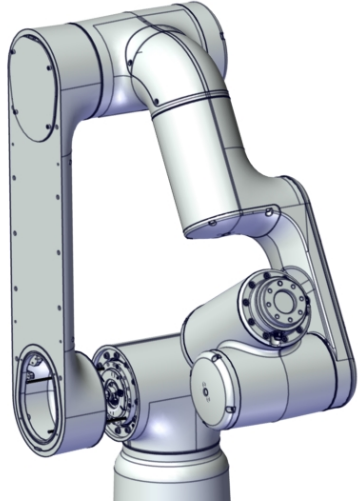
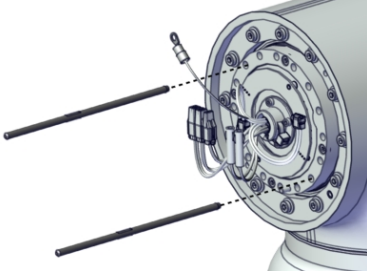
	Action	Note
6	Remove the complete arm system from the swing.	 <p>xx2000001941</p>
7	Remove the guide pins.	 <p>xx2000002432</p>

Removing the swing cover and insert (-10/1.52 and -12/1.27)

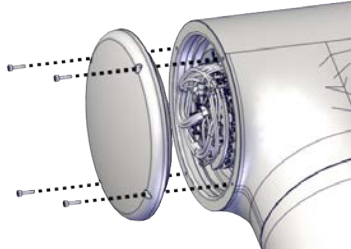
	Action	Note
1	 CAUTION Make sure that all supplies for electrical power are turned off.	
2	Remove the cover by removing the screws.	 <p>xx2300000814</p>

Continues on next page

5 Repair

5.6.4 Replacing the axis-2 joint unit (CRB 15000-10/1.52 and CRB 15000-12/1.27)

Continued

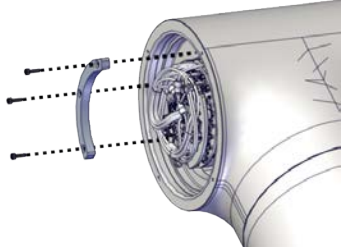
	Action	Note
3	 CAUTION Valid for CRB 15000-5/0.95 There is cabling connected between the cover and the joint unit drive board. Open the cover with care to avoid damage to the cabling or the connector(s). Do not leave the cover in location without being secured with the attachment screws.	
4	Remove the insert.	 xx2300000815

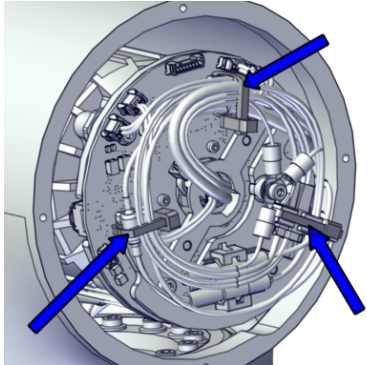

Disconnecting the axis-2 joint unit cabling

	Action	Note
1	 ELECTROSTATIC DISCHARGE (ESD) The unit is sensitive to ESD. Before handling the unit read the safety information in section The unit is sensitive to ESD on page 53 .	
2	Cut the cable ties.	 xx2000001946

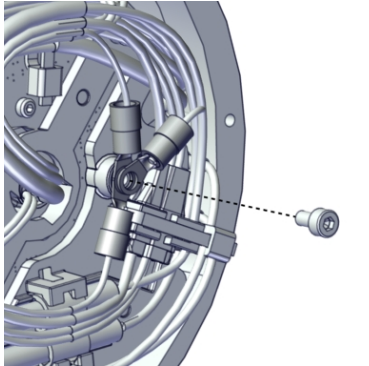
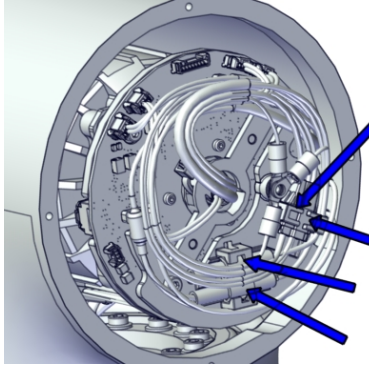

Continues on next page

5.6.4 Replacing the axis-2 joint unit (CRB 15000-10/1.52 and CRB 15000-12/1.27)

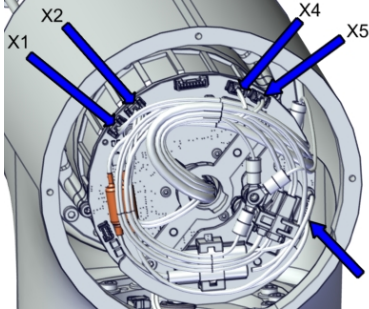
Continued

	Action	Note
3	Remove the functional and protective earth cables by removing the screw.	 <p>xx2000001945</p>
4	Snap loose and disconnect the connectors: <ul style="list-style-type: none"> • J2.DC+ • J2.DC- • J2.CS • J2.CP 	 <p>xx2000001944</p>
5	Disconnect the connectors from the drive board. <ul style="list-style-type: none"> • D2.X1 from X1 • D2.DC+ from DC+ • D2.DC- from ground • D2.X4 from X4 • D2.X2 from X2 • D2.X5 from X5 <p> CAUTION</p> Use tweezers to unlock connectors and pull them off.	 <p>xx2000002013</p>

Removing the base from foundation (-10/1.52 and -12/1.27)



	Action	Note
1	<p> CAUTION</p> The weight of the complete swing and base together is up to 25 kg	
2	<p> WARNING</p> Personnel must not, under any circumstances, be present under the suspended load.	

Continues on next page

5 Repair

5.6.4 Replacing the axis-2 joint unit (CRB 15000-10/1.52 and CRB 15000-12/1.27)

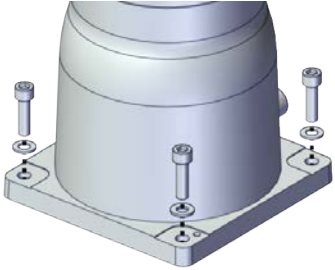
Continued

	Action	Note
3	Loosen the robot base from the foundation by removing the foundation attachment screws.	 <p data-bbox="991 611 1098 629">xx2300001060</p>
4	Lay the robot down with the torque sensor side upwards on a working bench. Do not damage the base socket. Caution with the cabling.  CAUTION The cabling is sensitive to mechanical damage. Handle it with care to avoid damage to the cabling or the connector, avoid any kind of tilt or skew.	



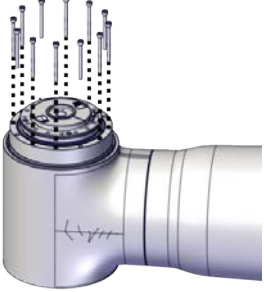

Removing the axis-2 joint unit

	Action	Note
1	Removing the attachment screws.	 <p data-bbox="1027 1413 1134 1431">xx2300000786</p>

Continues on next page

5.6.4 Replacing the axis-2 joint unit (CRB 15000-10/1.52 and CRB 15000-12/1.27)

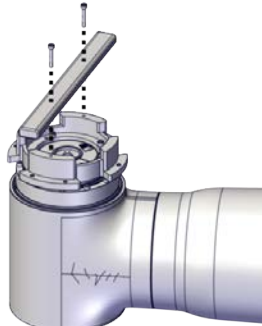
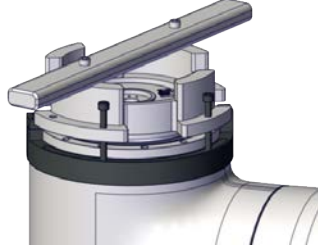
Continued

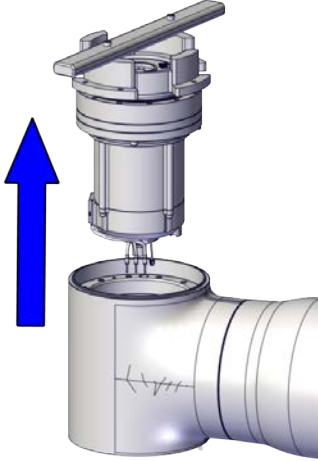
	Action	Note
2	<p>Fit the lifting aid to the joint unit, on the torque sensor side.</p> <p> CAUTION</p> <p>The connectors and the joint unit cables are sensitive to mechanical damage. Handle the assembly with care.</p>	<p>Lifting aid: 3HAC087787-001 Screws: M5x30 (4 pcs for plate and 2 pcs for beam)</p>  <p>xx2300000787</p>  <p>xx2300000788</p>
3	<p>Place the two semicircular blocks surrounding the joint unit, and use two fully threaded attachment screws as removal tools to press the joint unit out of position.</p>	 <p>xx2300000789</p>
4	<p>Remove the joint unit from the swing.</p> <p> CAUTION</p> <p>The connectors and the joint unit cables are sensitive to mechanical damage. Handle the assembly with care.</p>	 <p>xx2300000790</p>

Continues on next page



5 Repair

5.6.4 Replacing the axis-2 joint unit (CRB 15000-10/1.52 and CRB 15000-12/1.27)

Continued

	Action	Note
5	Remove the lifting aid.	 <p>xx2300000778</p> <p>xx2300000776</p>

Removing the joint cable

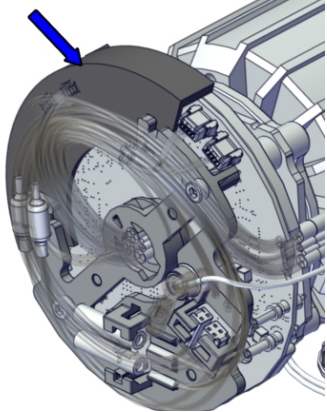
	Action	Note
1	 <p>ELECTROSTATIC DISCHARGE (ESD)</p> <p>The unit is sensitive to ESD. Before handling the unit read the safety information in section <i>The unit is sensitive to ESD on page 53</i>.</p>	
2	<p>Fit the protection plate to the drive board unit.</p>  <p>Tip</p> <p>Using the protection plate is important for protecting the drive board unit. If complete joint unit is to be replaced, the protection plate is not needed.</p>	<p>Protection plate: 3HAC077790-001 (for CRB 15000-5/0.95) / 3HAC087789-001 (for CRB 15000-10/1.52 and CRB 15000-12/1.27)</p>  <p>xx2000002057</p>

Continues on next page

5.6.4 Replacing the axis-2 joint unit (CRB 15000-10/1.52 and CRB 15000-12/1.27)

Continued

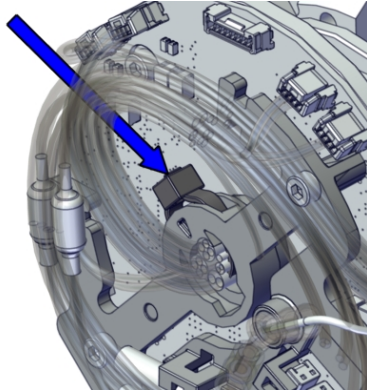
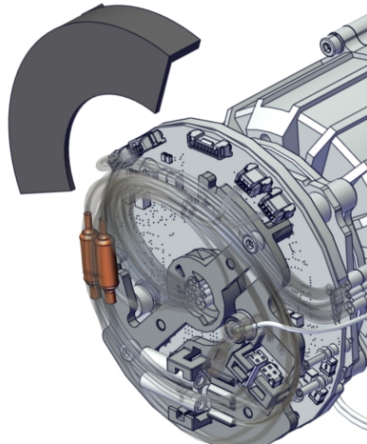
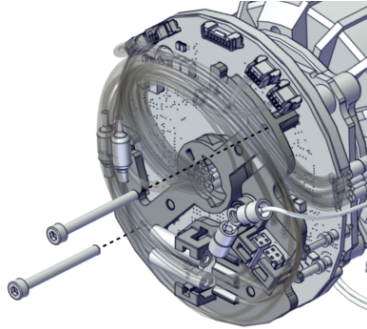
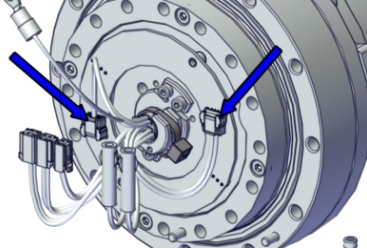

	Action	Note
3	Cut the cable tie at the drive board.	 <p>xx2000002058</p>
4	Remove the protection plate.	 <p>xx2100000301</p>
5	Remove the cable support from the drive board by removing the attachment screws.	 <p>xx2000002055</p>
6	Disconnect the two connectors from the torque sensor board. <ul style="list-style-type: none"> • TQ.A • TQ.B 	 <p>xx2000002053</p>

Continues on next page

5 Repair

5.6.4 Replacing the axis-2 joint unit (CRB 15000-10/1.52 and CRB 15000-12/1.27)

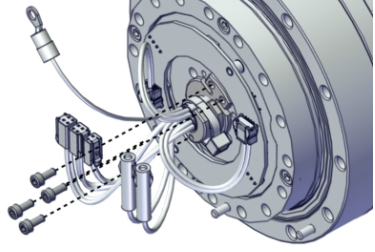

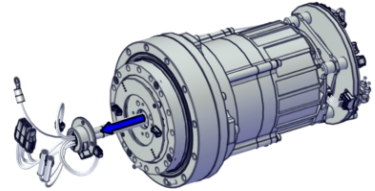
Continued

	Action	Note
7	Remove the cable plate by removing the attachment screws.	 xx2000002049
8	Remove the joint cable from the hollow shaft from the torque sensor side.  CAUTION The connectors and the joint unit cables are sensitive to mechanical damage. Handle the assembly with care.	 xx2000002060

Refitting the joint unit

Use these procedures to refit the joint unit.

Refitting the joint cable

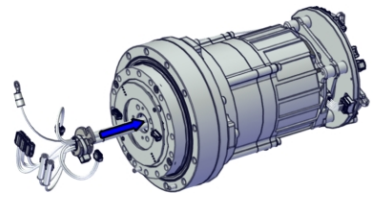
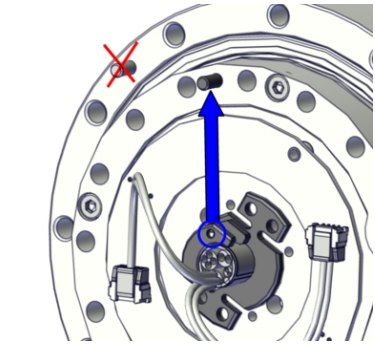
	Action	Note
1	 ELECTROSTATIC DISCHARGE (ESD) The unit is sensitive to ESD. Before handling the unit read the safety information in section The unit is sensitive to ESD on page 53 .	
2	Place the joint cable through the hollow shaft from the torque sensor side.  CAUTION The connectors and the joint unit cables are sensitive to mechanical damage. Handle the assembly with care.	 xx2000002048
3	Orient the cable plate according to the figure. The circle on the cable plate should point towards the guide pin on the torque sensor.	 xx2000002051

Continues on next page

5.6.4 Replacing the axis-2 joint unit (CRB 15000-10/1.52 and CRB 15000-12/1.27)

Continued

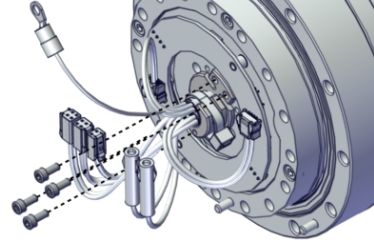
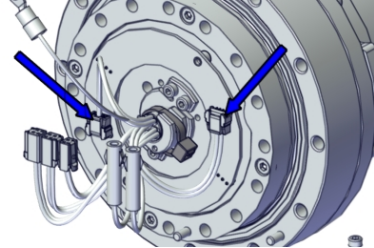
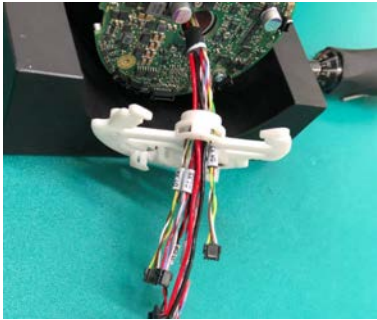
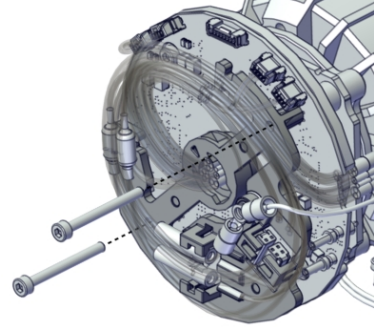
	Action	Note
4	Secure the cable plate to the joint unit with the attachment screws.	<p>Hex socket head cap screw: M2.5x6 12.9 Lafre 2C2B/FC6.9 (4 pcs) Tightening torque: 0.45 Nm.</p>  <p>xx2000002049</p>
5	<p>Connect the two connectors to the torque sensor board.</p> <ul style="list-style-type: none"> • TQ.A to CH1/A • TQ.B to CH2/B 	 <p>xx2000002053</p>
6	Insert the cabling through the cable support and fit the support to the drive board with the attachment screws.	 <p>xx2000002056</p> <p>Hex socket head cap screw: M3x30 12.9 Lafre 2C2B/FC6.9 (2 pcs) Tightening torque: 0.45 Nm.</p>  <p>xx2000002055</p>

Continues on next page

5 Repair

5.6.4 Replacing the axis-2 joint unit (CRB 15000-10/1.52 and CRB 15000-12/1.27)

Continued

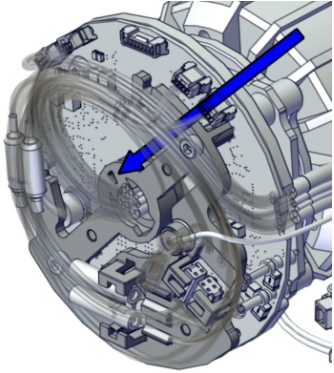
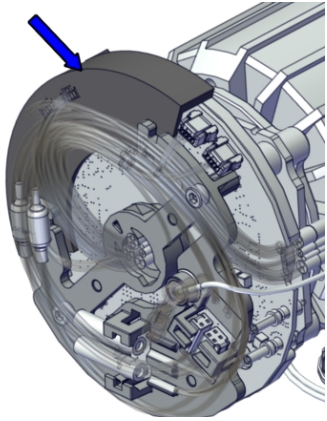
	Action	Note
7	Keep the cabling loose, making sure not to twist or strain it. Use the cable tie to pre-fix the cable by hand.	 xx2100000507
8	Fit the protection plate to the drive board unit.	Protection plate: 3HAC077790-001 (for CRB 15000-5/0.95) / 3HAC087789-001 (for CRB 15000-10/1.52 and CRB 15000-12/1.27)  xx2000002057

Continues on next page

5.6.4 Replacing the axis-2 joint unit (CRB 15000-10/1.52 and CRB 15000-12/1.27)

Continued

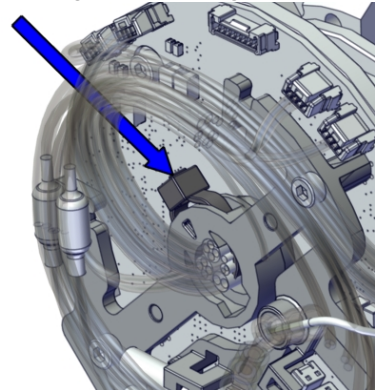
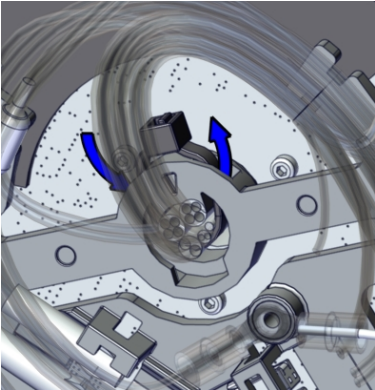
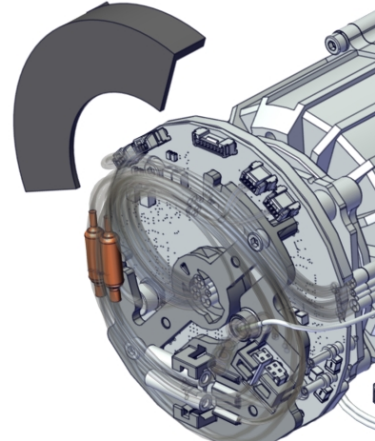
	Action	Note
9	<p>Secure the cables to the cable support with a cable tie, using a cable tie gun.</p> <p>Assembly direction for the cable tie is shown in the figure.</p>	<p>Cable tie: 3HAC075545-001. For securing joint unit cable.</p> <p>Cable tie gun EVO 7i</p> <p>Setting for cable tie gun: 6.75.</p>  <p>xx2000002058</p>  <p>xx2000002059</p>
10	<p>Remove the protection plate.</p>	 <p>xx2100000301</p>

Continues on next page

5 Repair

5.6.4 Replacing the axis-2 joint unit (CRB 15000-10/1.52 and CRB 15000-12/1.27)

Continued

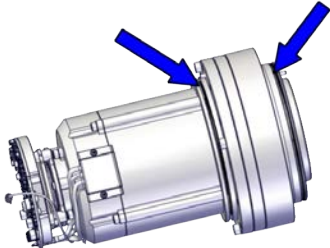
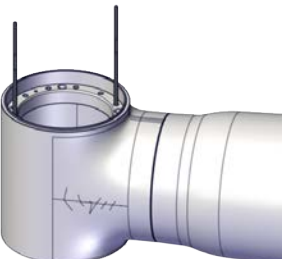

Refitting the axis-2 joint unit (-10/1.52 and -12/1.27)

	Action	Note
1	 <p>ELECTROSTATIC DISCHARGE (ESD)</p> <p>The unit is sensitive to ESD. Before handling the unit read the safety information in section <i>The unit is sensitive to ESD on page 53</i>.</p>	
2	<p>Check the o-rings. Replace if damaged.</p>	<p>O-ring: 3HAC061327-044</p>  <p>xx2300000823</p>
3	<p>Fit two guide pins to the swing.</p>	<p>Guide pin, M5x125: 3HAC087786-001</p> <p>Always use guide pins in pairs.</p> <p>For joint units on axes 1 and 2 of CRB 15000-10/1.52 and CRB 15000-12/1.27.</p>  <p>xx2300000791</p>

Continues on next page

5.6.4 Replacing the axis-2 joint unit (CRB 15000-10/1.52 and CRB 15000-12/1.27)

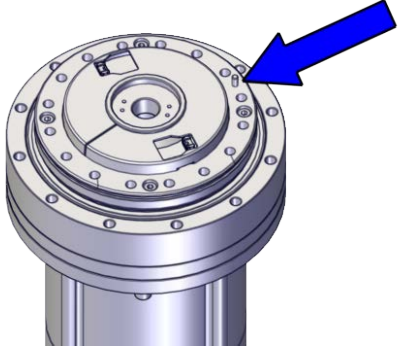
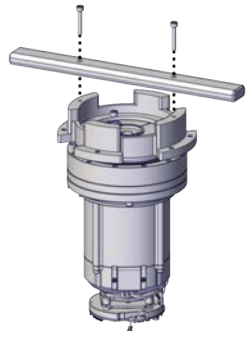
Continued

	Action	Note
4	<p>Fit the lifting aid to the joint unit, aligning the pin with the pin hole.</p> <p> CAUTION</p> <p>The connectors and the joint unit cables are sensitive to mechanical damage. Handle the assembly with care.</p>  <p>xx2300000777</p>	<p>Joint unit: 3HAC087472-001 Lifting aid: 3HAC087787-001 Screws: M5x30 (4 pcs for plate and 2 pcs for beam)</p>  <p>xx2300000778</p>  <p>xx2300000776</p>
5	<p>Place the axis-1 cabling properly to avoid squeezing by the joint unit when putting the joint unit into the swing.</p> <p> CAUTION</p> <p>The cabling is sensitive to mechanical damage. Handle it with care to avoid damage to the cabling or the connector, avoid any kind of tilt or skew.</p>	

Continues on next page

5 Repair

5.6.4 Replacing the axis-2 joint unit (CRB 15000-10/1.52 and CRB 15000-12/1.27)

Continued

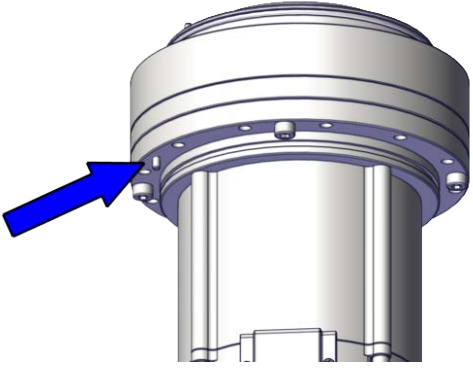
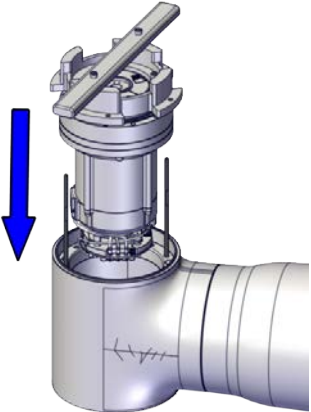
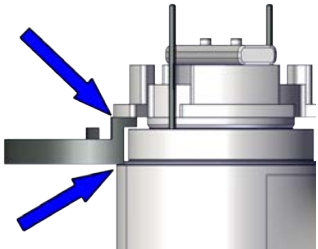
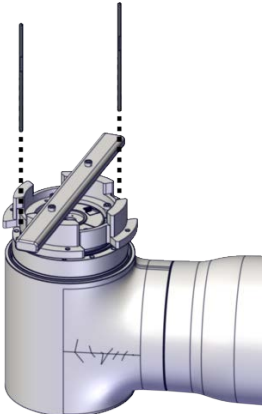
	Action	Note
6	<p>Fit the joint unit to the swing, aligning the pin with the pin hole.</p> <p> CAUTION</p> <p>The connectors and the joint unit cables are sensitive to mechanical damage. Handle the assembly with care.</p>  <p>xx2300000780</p>	 <p>xx2300000792</p>
7	<p>Check the joint unit position by placing the higher boss of one semicircular block between the lifting aid and swing.</p> <p>The joint unit is properly placed when no gaps between the block and both lifting aid and swing.</p>	 <p>xx2300000794</p>
8	<p>Remove the guide pins.</p>	 <p>xx2300000795</p>

Continues on next page

5.6.4 Replacing the axis-2 joint unit (CRB 15000-10/1.52 and CRB 15000-12/1.27)

Continued

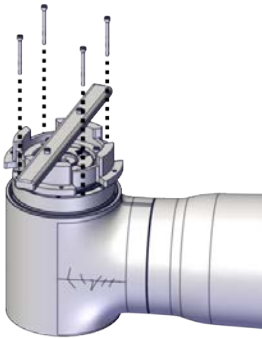
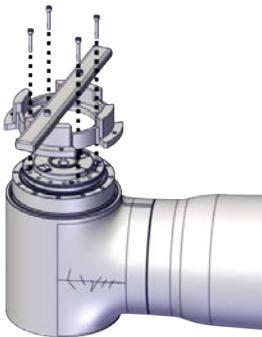
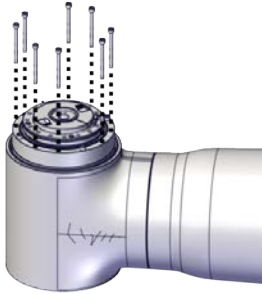
	Action	Note
9	Secure with four attachment screws and pre-tighten the screws crosswise.	 <p>xx2300000796</p>
10	Remove the lifting aid by removing the screws.	 <p>xx2300000797</p>
11	Secure the joint unit with the remaining attachment screws.	<p>Hex socket head cap screw: 3HAB3409-20</p>  <p>xx2300000798</p>
12	Torque tighten all screws crosswise.	<p>M5x55 12.9 Lafre 2C2B/FC6.9, 12 pcs Tightening torque: 8.2 Nm.</p>

Continues on next page

5 Repair

5.6.4 Replacing the axis-2 joint unit (CRB 15000-10/1.52 and CRB 15000-12/1.27)

Continued

Securing the base (-10/1.52 and -12/1.27)

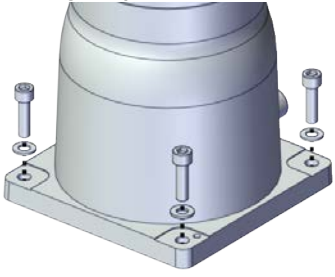
	Action	Note
1	Lift the base to standing and secure it to the foundation with the attachment screws and washers.	Attachment screws: M10x35 8.8 (4 pcs). Washers: 23/10.5/2.5 mm Steel (4 pcs). Tightening torque: 32 Nm \pm 10%.  xx2300001060

Connecting the axis-2 joint unit cabling

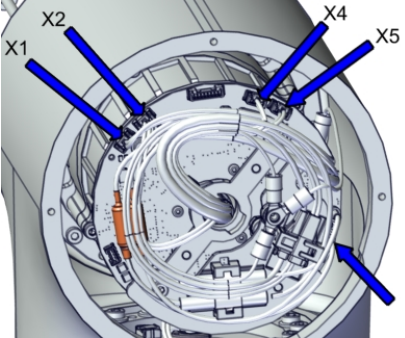
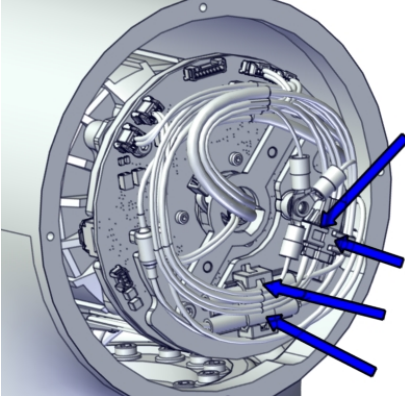
	Action	Note
1	 ELECTROSTATIC DISCHARGE (ESD) The unit is sensitive to ESD. Before handling the unit read the safety information in section The unit is sensitive to ESD on page 53 .	
2	Reconnect the connectors to the drive board. <ul style="list-style-type: none"> • D2.X1 to X1 • D2.DC+ to DC+ • D2.DC- to Ground • D2.X4 to X4 • D2.X2 to X2 • D2.X5 to X5 	 xx2000002013
3	Connect the connectors to each other and snap them to the cable holders. <ul style="list-style-type: none"> • J2.DC+ to J2.DC+ • J2.DC- to J2.DC- • J2.CS to J2.CS • J2.CP to J2.CP 	 xx2000001944

Continues on next page

5.6.4 Replacing the axis-2 joint unit (CRB 15000-10/1.52 and CRB 15000-12/1.27)

Continued

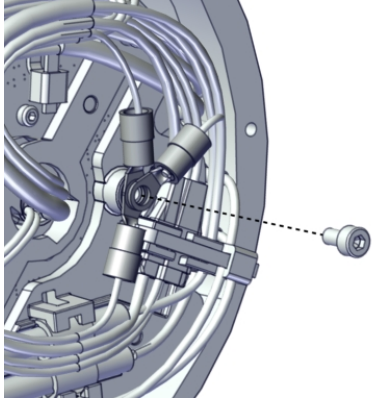
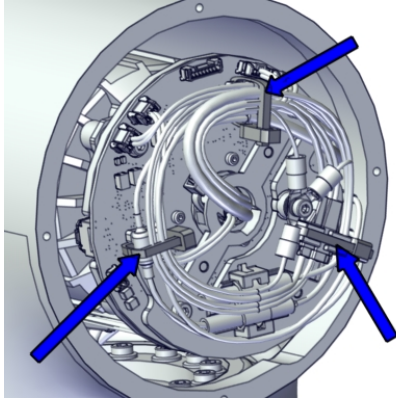
	Action	Note
4	Secure the cables for functional earth and protective earth with a screw.	<p>Hex socket head cap screw: M3x6 (1 pcs). Tightening torque: 0.8 Nm.</p>  <p>xx2000001945</p>
5	Secure the cabling with cable ties.	<p>Cable ties (3 pcs)</p>  <p>xx2000001946</p>

Refitting the swing cover and insert(-10/1.52 and -12/1.27)

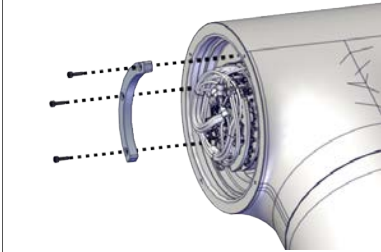
	Action	Note
1	Refit the insert.	<p>Insert: 3HAC084002-001 Hex socket head cap screw: M3x10 12.9 Lafre 2C2B/FC6.9 (3 pcs) Tightening torque: 1.4 Nm</p>  <p>xx2300000815</p>

Continues on next page



5 Repair

5.6.4 Replacing the axis-2 joint unit (CRB 15000-10/1.52 and CRB 15000-12/1.27)

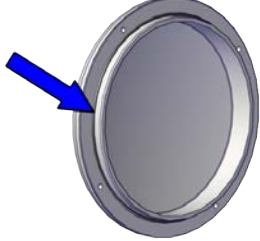
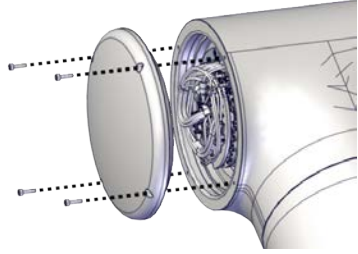
Continued

	Action	Note
2	Fit the o-ring to cover groove. Replace if damaged.	O-ring: 3HAC061327-074 (for CRB 15000-10/1.52 and CRB 15000-12/1.27)  xx2300000816
3	Refit the cover with the four screws.	Hex socket head cap screw: M3x12 12.9 Lafre 2C2B/FC6.9 (4 pcs) Tightening torque: 1.4 Nm  xx2300000814

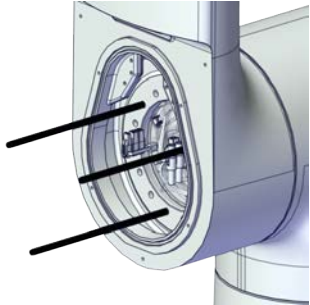



Refitting the lower and upper arm assembled (-10/1.52 and -12/1.27)

	Action	Note
1	Fit three guide pins to the axis-2 joint unit.	Guide pin, M5x125: 3HAC087786-001  xx2300001021
2	 CAUTION The weight of the complete upper and lower arm together is up to 26 kg	

Continues on next page

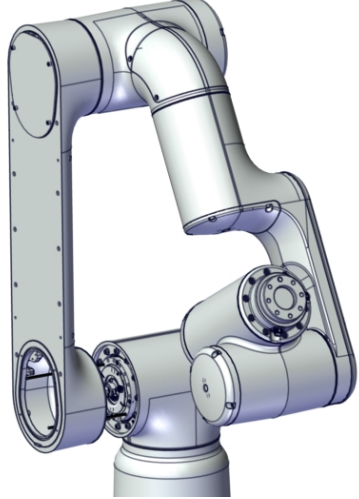
5.6.4 Replacing the axis-2 joint unit (CRB 15000-10/1.52 and CRB 15000-12/1.27)

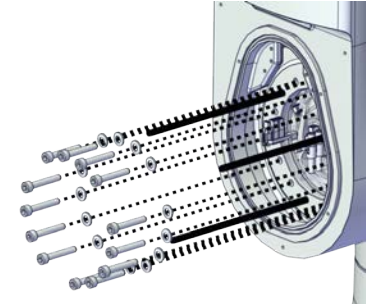
Continued

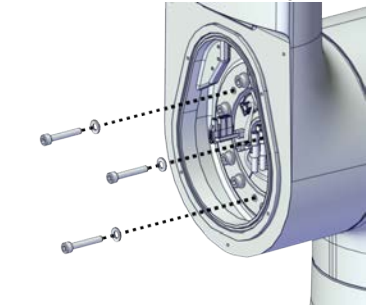
	Action	Note
3	<p>Lift the upper and lower arm assembly to mounting position and slide it onto the guide pins.</p>	<p>Example of CRB 15000-5/0.95, similar to CRB 15000-10/1.52 and CRB 15000-12/1.27.</p>  <p>xx2000001941</p>
4	<p>Secure the lower arm to the swing with all screws and washers but two. Pre-tighten the screws crosswise firstly.</p> <p> CAUTION</p> <p>Do not mix the flange screws used for CRB 15000-5/0.95 and the threaded screws used for CRB 15000-10/1.52 and CRB 15000-12/1.27. Always use washers together with the threaded screws for CRB 15000-10/1.52 and CRB 15000-12/1.27. Illustration is for reference only.</p>	<p>Hex socket head cap screw: M5x30 12.9 Lafre 2C2B/FC6.9, 16 pcs</p>  <p>xx2300001022</p>
5	<p>Remove the guide pins and fasten the remaining two screws and washers.</p> <p> CAUTION</p> <p>Do not mix the flange screws used for CRB 15000-5/0.95 and the threaded screws used for CRB 15000-10/1.52 and CRB 15000-12/1.27. Always use washers together with the threaded screws for CRB 15000-10/1.52 and CRB 15000-12/1.27. Illustration is for reference only.</p>	<p>Hex socket head cap screw: M5x30 12.9 Lafre 2C2B/FC6.9, 16 pcs</p>  <p>xx2300001023</p>
6	<p>Torque tighten all screws crosswise.</p>	<p>Tightening torque: 8.2 Nm</p>

Continues on next page

5 Repair

5.6.4 Replacing the axis-2 joint unit (CRB 15000-10/1.52 and CRB 15000-12/1.27)

Continued

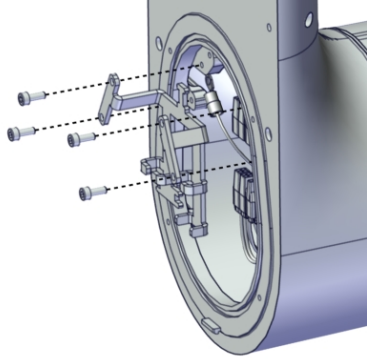
	Action	Note
7	Refit the cable bracket with four screws.	<p>Hex socket head cap screw: M3x8 12.9 Lafre 2C2B/FC6.9 (4 pcs). Tightening torque: 0.8 Nm</p>  <p>xx2000001939</p>

Connecting the cabling between the lower arm and swing

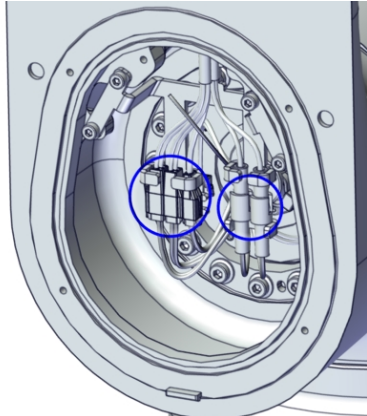
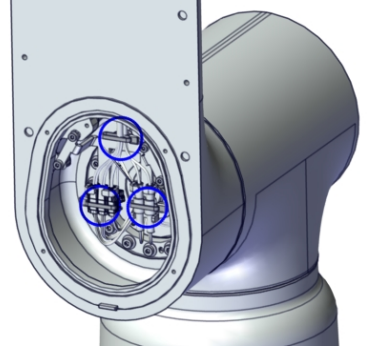
	Action	Note
1	Connect the connectors to each other and snap them to the cable holders.	 <p>xx2000001938</p>
2	Secure the cabling with cable ties.	<p>Cable ties (3 pcs)</p>  <p>xx2000001937</p>

Continues on next page

5.6.4 Replacing the axis-2 joint unit (CRB 15000-10/1.52 and CRB 15000-12/1.27)

Continued

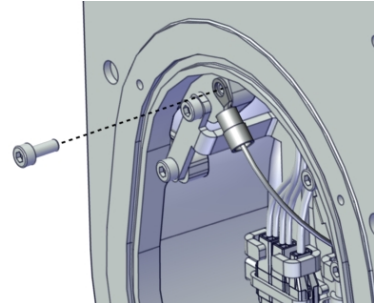
	Action	Note
3	Connect the functional earth cable with the screw.	<p>Hex socket head cap screw: M3x8 12.9 Lafre 2C2B/FC6.9 (1 pcs). Tightening torque: 0.8 Nm</p>  <p>xx2000001936</p>

Refitting the lower arm covers (-10/1.52 and -12/1.27)

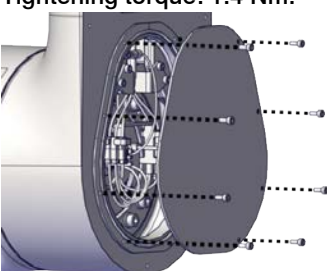
	Action	Note
1	Wipe, lubricate and fit the o-ring to its groove. Replace if damaged.	<p>O-ring: 3HAC061327-075 Grease: 3HAC042536-001 (Shell Gadus S2)</p>  <p>xx2000001954</p>
2	Refit the inner cover with four screws.	<p>Hex socket head cap screw: M3x8 12.9 Lafre 2C2B/FC6.9 (4 pcs) Tightening torque: 1.4 Nm.</p>  <p>xx2300000813</p>

Continues on next page

5 Repair

5.6.4 Replacing the axis-2 joint unit (CRB 15000-10/1.52 and CRB 15000-12/1.27)

Continued

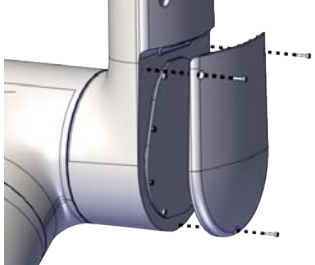
	Action	Note
3	Refit the lower cover of lower arm with three screws.	<p>Lower arm cover, lower: Lower arm, used for CRB 15000-10/1.52 and CRB 15000-12/1.27. Tightening torque: 1.4 Nm.</p>  <p>xx2300000812</p>

Concluding procedure

	Action	Note
1	<p>Calibrate the joint unit torque sensor.</p> <ol style="list-style-type: none"> 1 On the FlexPendant, go to the Code app and call the calibration procedure using PP to Routine, not by using Call Routine. 2 Select the Joint Unit Replacement feature and then select the axis to calibrate. 3 The controller is now restarted. Once the home screen of the FlexPendant is shown, press the Play button to continue the calibration routine. 4 The robot moves to a position or positions where measurements are performed. 5 The results of the measurements are presented together with the current values in the controller. Choose whether to save the calibration data or not. 6 If new calibration data is saved you will be asked to do a test with the lead-through functionality active to verify that the sensors work correctly. 7 Finally the robot is moved back to the original position. 8 Test the brake release (movement without drive power) functionality, see Testing the brake release functionality on page 196. 	See Calibration on page 1063
2	 <p>DANGER</p> <p>Make sure all safety requirements are met when performing the first test run. See Test run after installation, maintenance, or repair on page 90.</p>	

5.6.5 Replacing the axis-3 joint unit

Location of the axis-3 joint unit

The joint unit is located as shown in the figure.

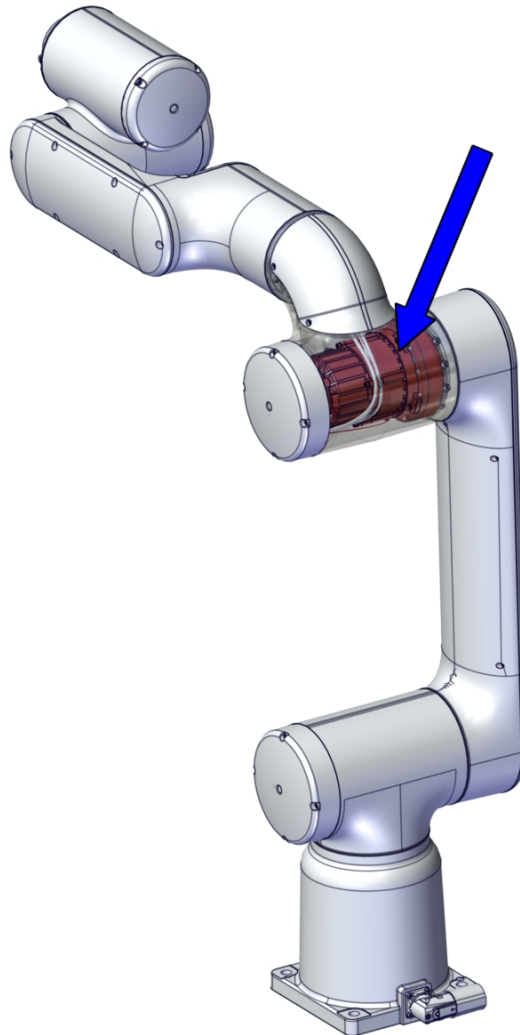

xx2000002020

Summary of the replacement procedure

This is a brief summary of the replacement procedure, containing the major actions to be performed.

- 1 Disconnect the cabling between the lower arm and the upper arm.
- 2 Remove the upper arm and place on a workbench.
- 3 Remove the housing cover.
- 4 Replace the joint unit. Move the cabling from old to new joint unit.

Continues on next page

5 Repair

5.6.5 Replacing the axis-3 joint unit

Continued

Required spare parts



Note

The spare part numbers that are listed in the table can be out of date. See the latest spare parts of the CRB 15000 via myABB Business Portal, www.abb.com/myABB.

Spare part	Article number	Note
Joint unit	3HAC079141-001	Used for CRB 15000-5/0.95. New attachment screws and cable tie 3HAC075545-001 are included in the delivery. Used for CRB 15000-5/0.95.
Joint unit	3HAC087474-001	Used for CRB 15000-10/1.52 and CRB 15000-12/1.27. New O-ring 3HAC061327-036 and cable tie 3HAC075545-001 are included in the delivery.

Required tools and equipment

Equipment	Article number	Note
Lifting aid	3HAC077788-001	For joint units on axes 1, 2 and 3 of CRB 15000-5/0.95. Attachment screws M4x35 (4 pcs) are enclosed.
Lifting aid	3HAC087788-001	For joint unit on axis 3 of CRB 15000-10/1.52 and CRB 15000-12/1.27.
Guide pin, M4x120	3HAC077786-001	Always use guide pins in pairs. For joint units on axes 1, 2 and 3 of CRB 15000-5/0.95 and axis 3 of CRB 15000-10/1.52 and CRB 15000-12/1.27.
Protection plate	3HAC077790-001	For protection of drive board during cabling installation on joint units of CRB 15000-5/0.95.
Protection plate	3HAC087789-001	For protection of drive board during cabling installation on joint units of CRB 15000-10/1.52 and CRB 15000-12/1.27.
Cable tie gun EVO 7i	-	HellermannTyton 110-77001 or similar
Standard toolkit	-	Content is defined in section Standard toolkit on page 1099 .

Required consumables

Consumable	Article number	Note
Cleaning agent	-	Isopropanol
Flange sealant	-	Loctite 574

Continues on next page



5.6.5 Replacing the axis-3 joint unit
Continued

Consumable	Article number	Note
Cable ties	-	
O-ring	3HAC061327-036	Axis-3 joint unit, used for CRB 15000-10/1.52 and CRB 15000-12/1.27. Replace if damaged.
O-ring	3HAC061327-047	Cover for axis 2/3, used for CRB 15000-5/0.95. Replace if damaged.
O-ring	3HAC061327-047	Housing cover, used for CRB 15000-10/1.52 and CRB 15000-12/1.27. Replace if damaged.
O-ring	3HAC061327-044	Lower arm, inner cover of CRB 15000-5/0.95. 1 pcs / cover. Replace if damaged.
O-ring	3HAC061327-044	Lower arm, upper inner cover of CRB 15000-10/1.52 and CRB 15000-12/1.27. Replace if damaged.

Removing the joint unit

Use these procedures to remove the joint unit.

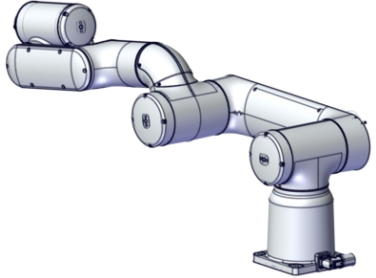
Preparations before removing the joint unit

	Action	Note
1	<p>Jog the robot to the specified position:</p> <ul style="list-style-type: none"> • Axis 1: 0° • Axis 2: +90° (suggested position for convenient working position) • Axis 3: -80° (home position) • Axis 4: 0° • Axis 5: 0° • Axis 6: 0° <p> CAUTION</p> <p>Jog the axis on which the joint unit is to be replaced to home position, to achieve correct cable routing during replacement of the joint unit.</p>	<p>Example of CRB 15000-5/0.95, similar to CRB 15000-10/1.52 and CRB 15000-12/1.27.</p>  <p>xx210000002</p>
2	<p> CAUTION</p> <p>Turn off all supplies for electrical power to the robot, before starting the repair work.</p>	

Continues on next page

5 Repair

5.6.5 Replacing the axis-3 joint unit

Continued

Removing the lower arm covers (-5/0.95)

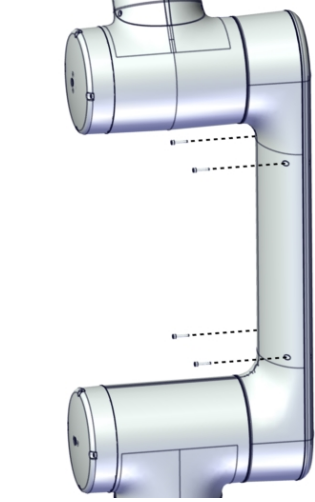
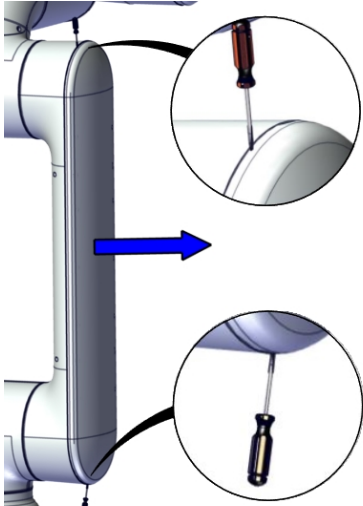
	Action	Note
1	 CAUTION Make sure that all supplies for electrical power are turned off.	
2	Remove the four lower arm cover screws.	 xx2000001929
3	Remove the cover by inserting a small flat screwdriver to snap open the locks at each end of the cover.	 xx2100000267

Continues on next page

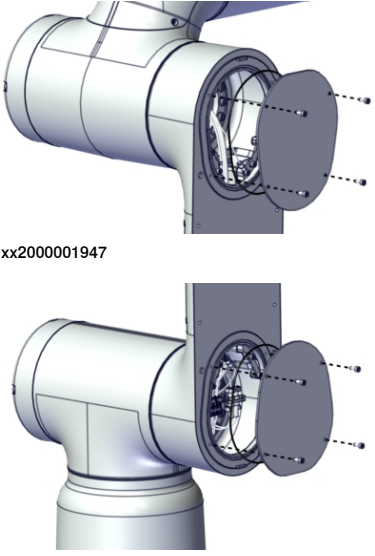
	Action	Note
4	Remove the inner covers by removing the screws.	 <p data-bbox="1061 548 1173 571">xx2000001947</p> <p data-bbox="1061 862 1173 884">xx2000001930</p>

Removing the lower arm covers (-10/1.52 and -12/1.27)

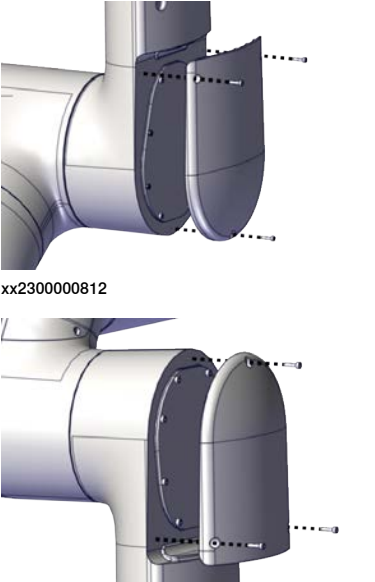
	Action	Note
1	 <p data-bbox="598 1059 718 1093">CAUTION</p> <p data-bbox="510 1115 1037 1171">Make sure that all supplies for electrical power are turned off.</p>	
2	Remove the lower arm covers by removing the screws.	 <p data-bbox="1061 1473 1173 1496">xx2300000812</p> <p data-bbox="1061 1787 1173 1809">xx2300000829</p>

Continues on next page

5 Repair

5.6.5 Replacing the axis-3 joint unit

Continued

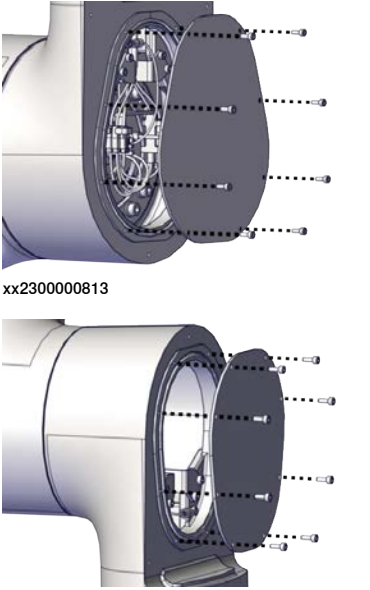
	Action	Note
3	Remove the inner covers by removing the screws.	 <p data-bbox="1029 584 1136 607">xx230000813</p> <p data-bbox="1029 902 1136 925">xx230000830</p>

Disconnecting the upper arm cabling

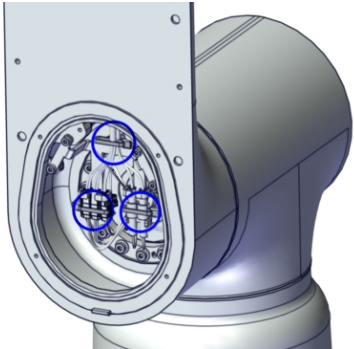
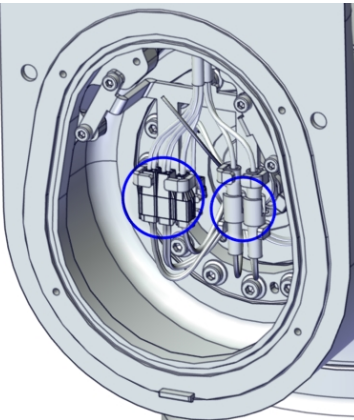

	Action	Note
1	Cut the cable ties.	 <p data-bbox="1029 1420 1136 1442">xx2000001937</p>
2	Snap loose and disconnect all connectors.	 <p data-bbox="1029 1897 1136 1919">xx2000001938</p>

Continues on next page

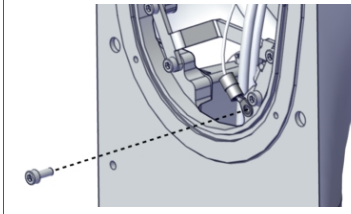
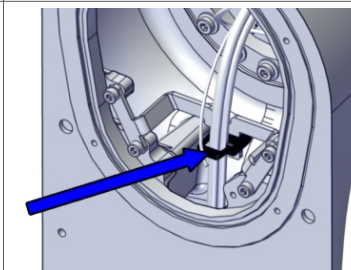
Loosening the cabling between the lower and upper arm

	Action	Note
1	Remove the functional earth cable by removing the screw.	 <p>xx2000001964</p>
2	Cut the cable tie.	 <p>xx2000001965</p>

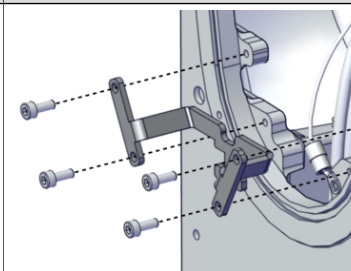
Removing the upper arm

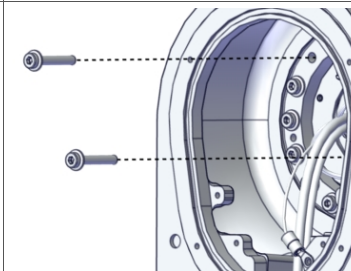
	Action	Note
1	Remove the cable bracket by removing the four screws.	 <p>xx2000001966</p>
2	Secure the weight of the upper arm.  CAUTION The weight of the complete upper arm is 14 kg.	
3	Remove two attachment screws.	 <p>xx2000001967</p>

Continues on next page

5 Repair

5.6.5 Replacing the axis-3 joint unit

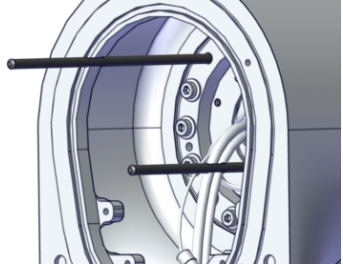
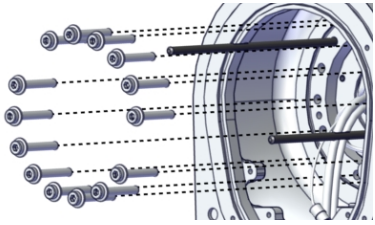
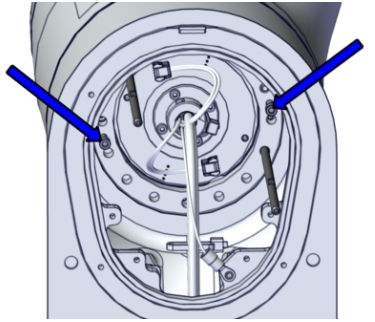
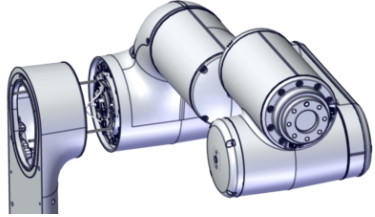

Continued

	Action	Note
4	Fit two guide pins to the axis-3 joint unit.	<p>Guide pin, M4x120: 3HAC077786-001</p> <p>Always use guide pins in pairs.</p>  <p>xx2000001968</p>
5	Remove the remaining attachment screws.	 <p>xx2000001969</p>
6	Press the upper arm out of position by using two fully threaded attachment screws as removal tools.	 <p>xx2100000001</p>
7	<p>Remove the upper arm from the lower arm.</p> <p>Assist the cabling to be removed from the lower arm while lifting away the complete upper arm.</p> <p>Place the upper arm on a workbench.</p>	 <p>xx2000001970</p>

Removing the housing cover (-5/0.95)

	Action	Note
1	 <p>CAUTION</p> <p>Make sure that all supplies for electrical power are turned off.</p>	

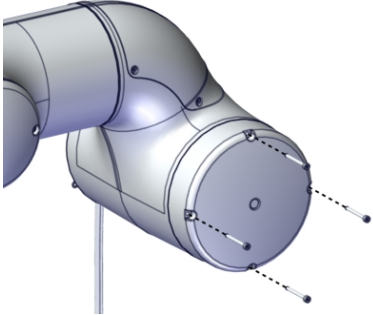
Continues on next page

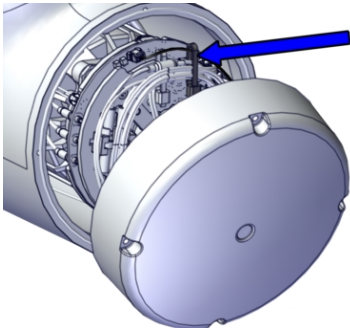
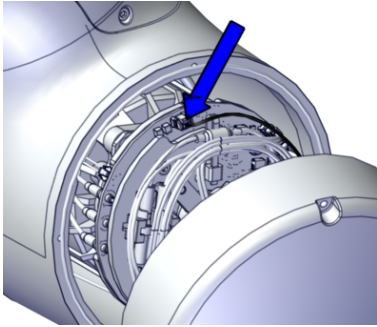
	Action	Note
2	Remove the cover screws.	 <p>xx2000002021</p>
3	<p> CAUTION</p> <p>Valid for CRB 15000-5/0.95</p> <p>There is cabling connected between the cover and the joint unit drive board.</p> <p>Open the cover with care to avoid damage to the cabling or the connector(s).</p> <p>Do not leave the cover in location without being secured with the attachment screws.</p>	
4	<p>For robots with RobotWare earlier than 7.10</p> <p>Open the cover and cut the cable tie that holds the brake release cable.</p>	 <p>xx2000002022</p>
5	<p>For robots with RobotWare earlier than 7.10</p> <p>Disconnect the brake release connector DR.X8 from the drive board.</p> <p>Remove the cover.</p>	 <p>xx2000002023</p>



Continues on next page

5 Repair

5.6.5 Replacing the axis-3 joint unit

Continued

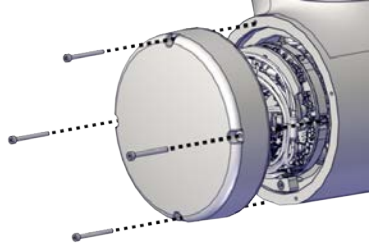
Removing the housing cover and insert (-10/1.52 and -12/1.27)

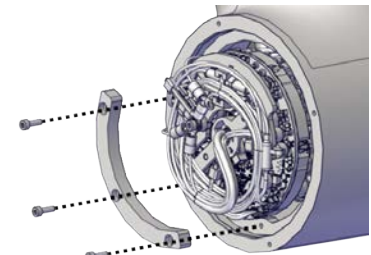
	Action	Note
1	 CAUTION Make sure that all supplies for electrical power are turned off.	
2	Remove the cover by removing the screws.	 xx2300000833
3	 CAUTION Valid for CRB 15000-5/0.95 There is cabling connected between the cover and the joint unit drive board. Open the cover with care to avoid damage to the cabling or the connector(s). Do not leave the cover in location without being secured with the attachment screws.	
4	Remove the insert.	 xx2300000834

Continues on next page

Disconnecting the axis-3 joint unit cabling

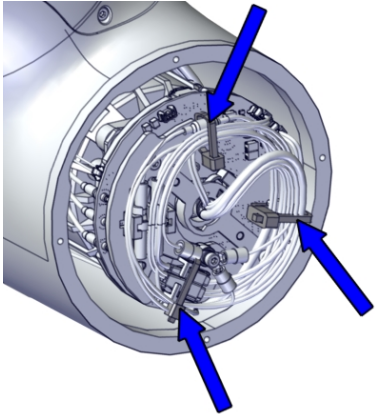
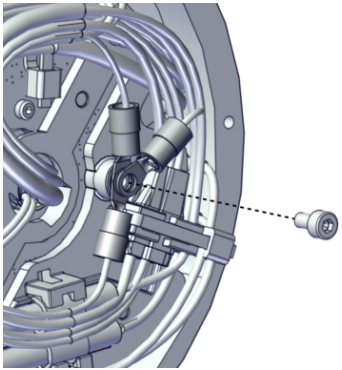
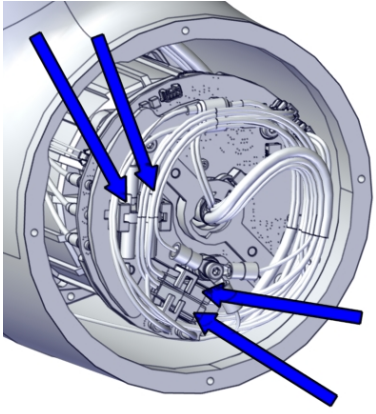
	Action	Note
1	Cut the cable ties.	 <p>xx2000002066</p>
2	Remove the functional and protective earth cables by removing the screw.	 <p>xx2000001945</p>
3	Snap loose and disconnect the connectors: <ul style="list-style-type: none"> • J4.DC+ • J4.DC- • J4.CS • J4.CP 	 <p>xx2000002067</p>

Continues on next page

5 Repair

5.6.5 Replacing the axis-3 joint unit

Continued

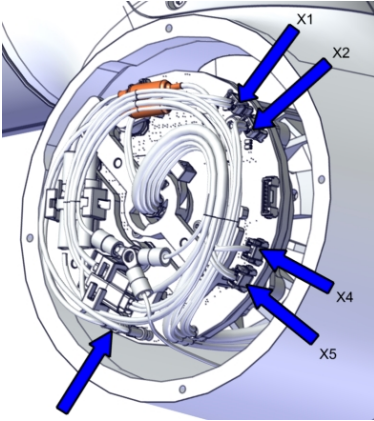

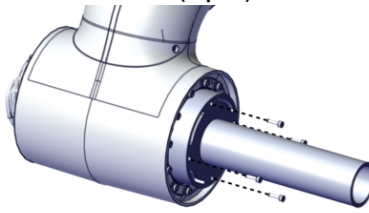
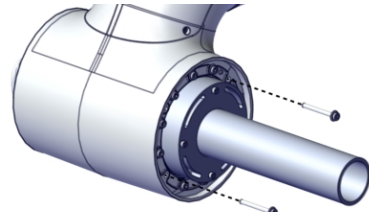
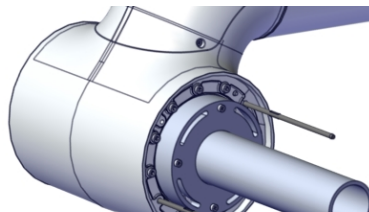

	Action	Note
4	<p>Disconnect the connectors from the drive board.</p> <ul style="list-style-type: none"> • D3.X1 • D3/4.DC+ • D3/4.DC- • D3.X4 • D3/4.X2 • D3.X5 <p> CAUTION</p> <p>Use tweezers to unlock connectors and pull them off.</p>	 <p>xx2000002068</p>

Removing the axis-3 joint unit (-5/0.95)

	Action	Note
1	<p>Fit the lifting aid to the joint unit, on the torque sensor side.</p> <p> CAUTION</p> <p>The connectors and the joint unit cables are sensitive to mechanical damage. Handle the assembly with care.</p>	<p>Lifting aid: 3HAC077788-001 Screws: M4x35 (4 pcs)</p>  <p>xx2000002069</p>
2	<p>Remove two attachment screws. Dispose the screws. New screws are included in the spare part delivery of the joint unit.</p>	 <p>xx2000002070</p>
3	<p>Fit two guide pins to the axis-3 joint unit.</p>	<p>Guide pin, M4x120: 3HAC077786-001 Always use guide pins in pairs. For joint units on axes 1, 2 and 3 of CRB 15000-5/0.95 and axis 3 of CRB 15000-10/1.52 and CRB 15000-12/1.27.</p>  <p>xx2000002576</p>

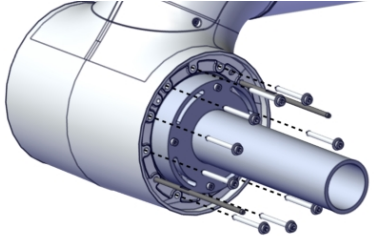
Continues on next page

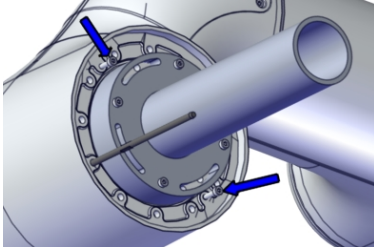
5.6.5 Replacing the axis-3 joint unit
Continued

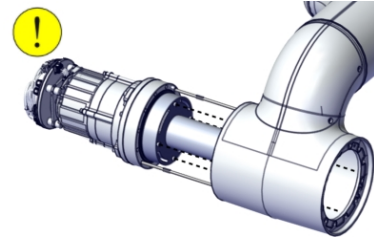
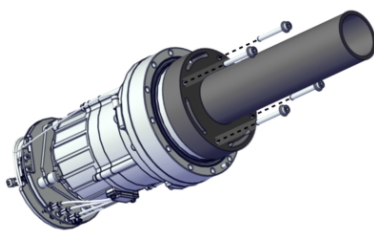
	Action	Note
4	<p>Remove the remaining attachment screws. Use two screws as press out screws in the upcoming step, then dispose all screws. New screws are included in the spare part delivery of the joint unit.</p>	 <p>xx2100000320</p>
5	<p>Put the cabling at the slot in order not to squeeze it during removal of joint unit.</p>	 <p>xx2100000003</p>
6	<p>Press the joint unit out of position using two of the previous attachment screws as removal tools.</p>	 <p>xx2000002577</p>
7	<p>Remove the joint unit from the housing.</p> <p> CAUTION</p> <p>The connectors and the joint unit cables are sensitive to mechanical damage. Handle the assembly with care.</p>	 <p>xx2000002071</p>
8	<p>Remove the lifting aid and guide pins.</p>	 <p>xx2000001957</p>





Continues on next page

5 Repair

5.6.5 Replacing the axis-3 joint unit

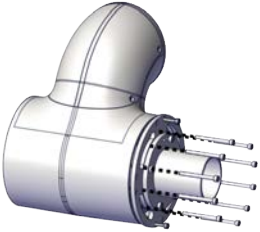

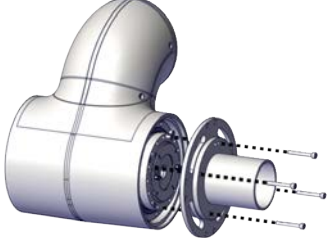
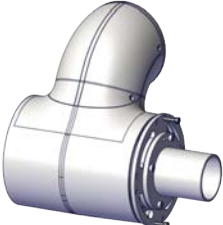
Continued

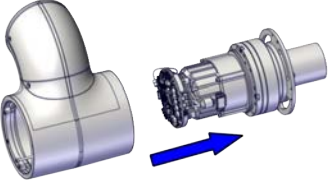
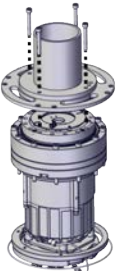
Removing the axis-3 joint unit (-10/1.52 and -12/1.27)

	Action	Note
1	Remove the attachment screws.	 <p>xx2300000799</p>
2	Fit the lifting aid to the joint unit, on the torque sensor side.  CAUTION The connectors and the joint unit cables are sensitive to mechanical damage. Handle the assembly with care.	Lifting aid: 3HAC087788-001 Screws: M4x30 (4 pcs)  <p>xx2300000800</p>
3	Use two fully attachment screws as removal tools to press the joint unit out of position.	 <p>xx2300000801</p>
4	Remove the joint unit from the housing.  CAUTION The connectors and the joint unit cables are sensitive to mechanical damage. Handle the assembly with care.	 <p>xx2300000802</p>
5	Remove the lifting aid.	 <p>xx2300000804</p>

Continues on next page

Removing the joint cable

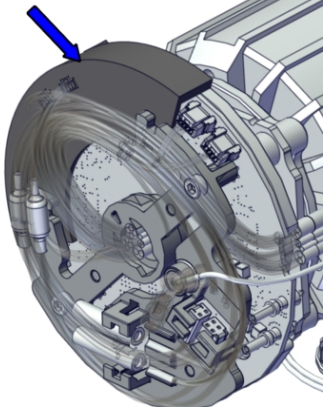
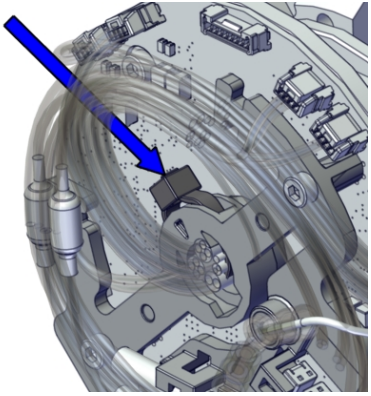
	Action	Note
1	 <p>ELECTROSTATIC DISCHARGE (ESD)</p> <p>The unit is sensitive to ESD. Before handling the unit read the safety information in section <i>The unit is sensitive to ESD on page 53</i>.</p>	
2	<p>Fit the protection plate to the drive board unit.</p>  <p>Tip</p> <p>Using the protection plate is important for protecting the drive board unit. If complete joint unit is to be replaced, the protection plate is not needed.</p>	<p>Protection plate: 3HAC077790-001 (for CRB 15000-5/0.95) / 3HAC087789-001 (for CRB 15000-10/1.52 and CRB 15000-12/1.27)</p>  <p>xx2000002057</p>
3	<p>Cut the cable tie at the drive board.</p>	 <p>xx2000002058</p>

Continues on next page

5 Repair

5.6.5 Replacing the axis-3 joint unit

Continued

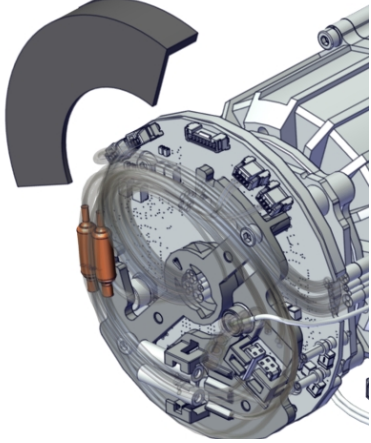
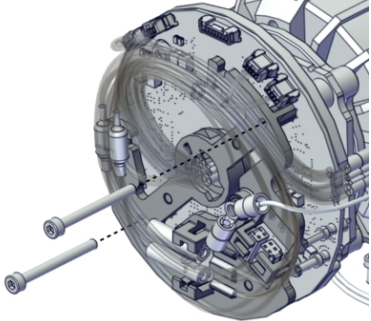
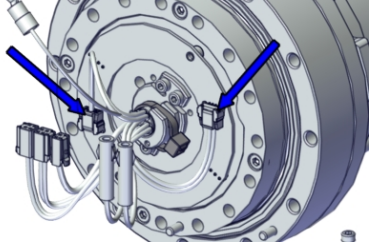
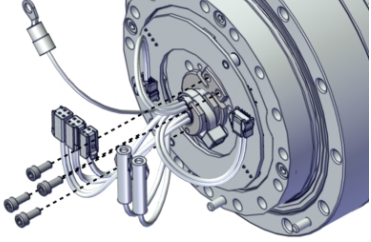
	Action	Note
4	Remove the protection plate.	 xx2100000301
5	Remove the cable support from the drive board by removing the attachment screws.	 xx2000002055
6	Disconnect the two connectors from the torque sensor board. <ul style="list-style-type: none">• TQ.A• TQ.B	 xx2000002053
7	Remove the cable plate by removing the attachment screws.	 xx2000002049

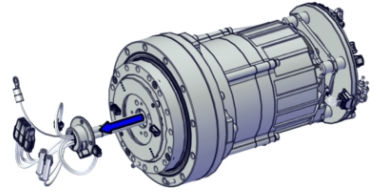

Continues on next page

	Action	Note
8	<p>Remove the joint cable from the hollow shaft from the torque sensor side.</p> <p> CAUTION</p> <p>The connectors and the joint unit cables are sensitive to mechanical damage. Handle the assembly with care.</p>	 <p>xx2000002060</p>

Refitting the joint unit

Use these procedures to refit the joint unit.

Refitting the joint cable

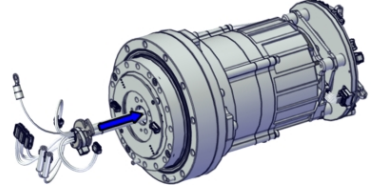
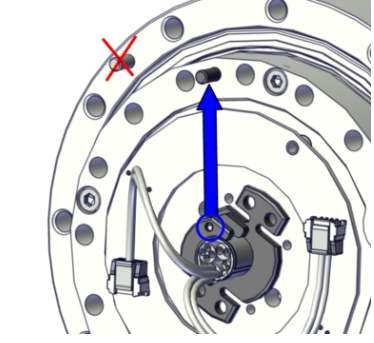
	Action	Note
1	<p> ELECTROSTATIC DISCHARGE (ESD)</p> <p>The unit is sensitive to ESD. Before handling the unit read the safety information in section The unit is sensitive to ESD on page 53.</p>	
2	<p>Place the joint cable through the hollow shaft from the torque sensor side.</p> <p> CAUTION</p> <p>The connectors and the joint unit cables are sensitive to mechanical damage. Handle the assembly with care.</p>	 <p>xx2000002048</p>
3	<p>Orient the cable plate according to the figure. The circle on the cable plate should point towards the guide pin on the torque sensor.</p>	 <p>xx2000002051</p>

Continues on next page

5 Repair

5.6.5 Replacing the axis-3 joint unit

Continued

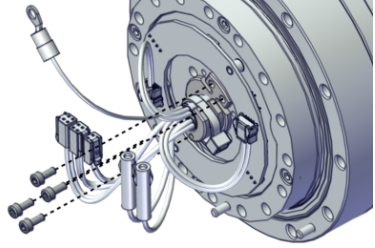
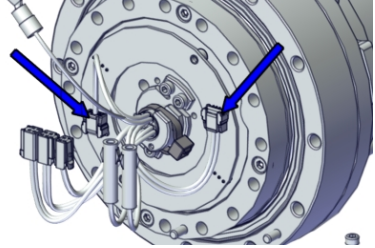
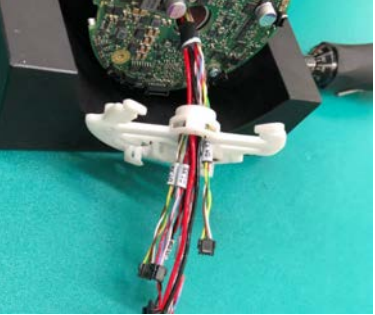
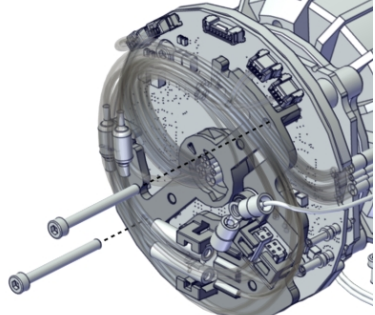
	Action	Note
4	Secure the cable plate to the joint unit with the attachment screws.	<p>Hex socket head cap screw: M2.5x6 12.9 Lafre 2C2B/FC6.9 (4 pcs) Tightening torque: 0.45 Nm.</p>  <p>xx2000002049</p>
5	<p>Connect the two connectors to the torque sensor board.</p> <ul style="list-style-type: none"> • TQ.A to CH1/A • TQ.B to CH2/B 	 <p>xx2000002053</p>
6	Insert the cabling through the cable support and fit the support to the drive board with the attachment screws.	 <p>xx2000002056</p> <p>Hex socket head cap screw: M3x30 12.9 Lafre 2C2B/FC6.9 (2 pcs) Tightening torque: 0.45 Nm.</p>  <p>xx2000002055</p>

Continues on next page

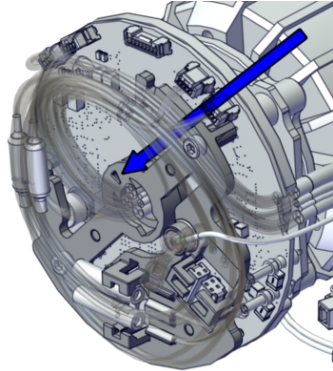
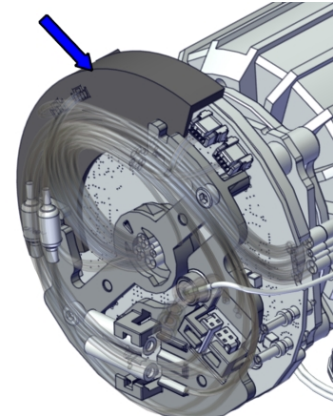
	Action	Note
7	<p>Keep the cabling loose, making sure not to twist or strain it. Use the cable tie to pre-fix the cable by hand.</p>	 <p>xx2100000507</p>
8	<p>Fit the protection plate to the drive board unit.</p>	<p>Protection plate: 3HAC077790-001 (for CRB 15000-5/0.95) / 3HAC087789-001 (for CRB 15000-10/1.52 and CRB 15000-12/1.27)</p>  <p>xx2000002057</p>

Continues on next page

5 Repair

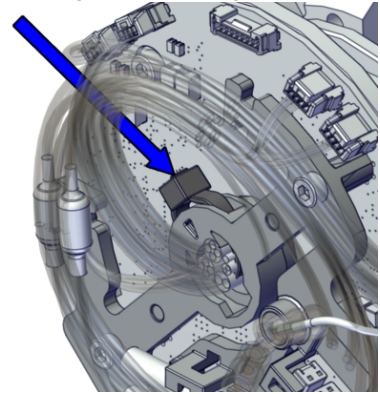
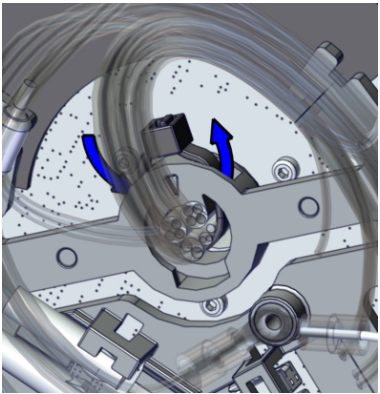
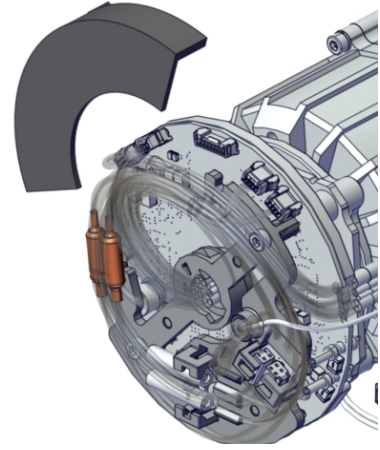

5.6.5 Replacing the axis-3 joint unit

Continued

	Action	Note
9	<p>Secure the cables to the cable support with a cable tie, using a cable tie gun.</p> <p>Assembly direction for the cable tie is shown in the figure.</p>	<p>Cable tie: 3HAC075545-001. For securing joint unit cable.</p> <p>Cable tie gun EVO 7i</p> <p>Setting for cable tie gun: 6.75.</p>  <p>xx200002058</p>  <p>xx200002059</p>
10	<p>Remove the protection plate.</p>	 <p>xx210000301</p>

Continues on next page

Preparations before fitting the joint unit (-5/0.95)

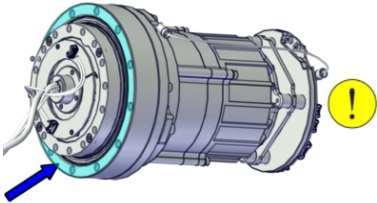
	Action	Note
1	 ELECTROSTATIC DISCHARGE (ESD) The unit is sensitive to ESD. Before handling the unit read the safety information in section <i>The unit is sensitive to ESD on page 53</i> .	
2	Clean the mounting surface of the joint unit and the mating surface on the casting with isopropanol. Joint unit mounting surface is pointed out in the figure.	Cleaning agent: Isopropanol Flange sealant: Loctite 574
3	Apply a thin layer of flange sealant to the mounting surface. Do not contaminate the radial sealing with sealant.  CAUTION The connectors and the joint unit cables are sensitive to mechanical damage. Handle the assembly with care.  ELECTROSTATIC DISCHARGE (ESD) The unit is sensitive to ESD. Before handling the unit read the safety information in section <i>The unit is sensitive to ESD on page 53</i> .	 xx2000001860

Refitting the axis-3 joint unit (-5/0.95)

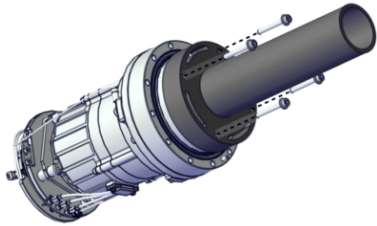

	Action	Note
1	Fit the lifting aid to the joint unit.  CAUTION The connectors and the joint unit cables are sensitive to mechanical damage. Handle the assembly with care.	Joint unit: 3HAC079141-001 Lifting aid: 3HAC07788-001 Screws: M4x35 (4 pcs)  xx2000001957

Continues on next page

5 Repair

5.6.5 Replacing the axis-3 joint unit

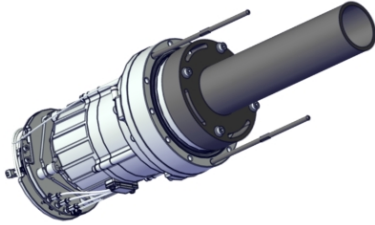
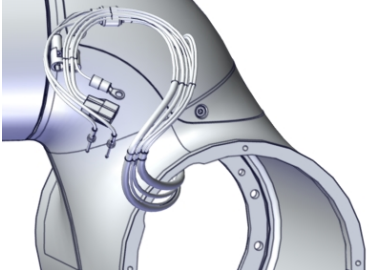
Continued

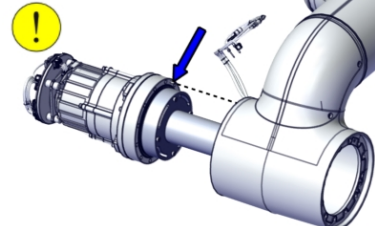
	Action	Note
2	Fit two guide pins to the joint unit.	<p>Guide pin, M4x120: 3HAC077786-001</p> <p>Always use guide pins in pairs.</p> <p>For joint units on axes 1, 2 and 3 of CRB 15000-5/0.95 and axis 3 of CRB 15000-10/1.52 and CRB 15000-12/1.27.</p>  <p>xx2000002438</p>
3	Place the cabling at the slot before refitting the joint unit.	 <p>xx2100000004</p>
4	<p>Fit the joint unit to the housing, aligning the pin with the pin hole.</p> <p> CAUTION</p> <p>The connectors and the joint unit cables are sensitive to mechanical damage. Handle the assembly with care.</p>	 <p>xx2000002072</p>

Continues on next page

5.6.5 Replacing the axis-3 joint unit
Continued

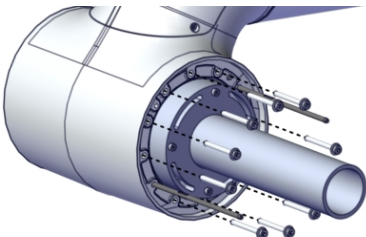
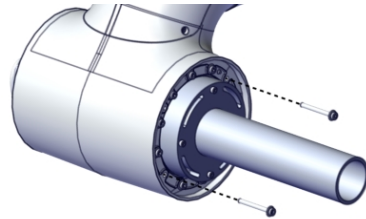
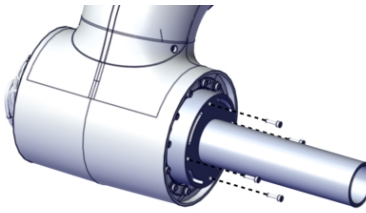
	Action	Note
5	Secure the joint unit with new attachment screws.	<p>Flange socket head screw with glue: 3HAB3413-435 M4x35 12.9 Lafre 2C2B/FC6.9+PrO-COat111, with NYPLAS glue , 12 pcs Used for joint unit of CRB 15000-5/0.95.</p> <p>Always use new screws when refitting a joint unit. If ordering a new joint unit spare part, new screws are included.</p>  <p>xx2100000320</p>
6	Remove the guide pins and secure the remaining two attachment screws.	 <p>xx2000002070</p>
7	Pre-tighten the screws crosswise.	
8	Torque tighten all screws crosswise.	Tightening torque: 4.3 Nm.
9	Remove the lifting aid by removing the screws.	 <p>xx2000002069</p>
10	Clean pushed-out flange sealant, if any.	

Refitting the axis-3 joint unit (-10/1.52 and -12/1.27)



	Action	Note
1	 <p>ELECTROSTATIC DISCHARGE (ESD)</p> <p>The unit is sensitive to ESD. Before handling the unit read the safety information in section The unit is sensitive to ESD on page 53.</p>	

Continues on next page

5 Repair

5.6.5 Replacing the axis-3 joint unit

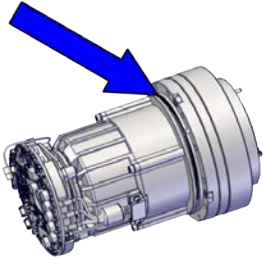
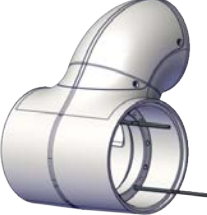
Continued

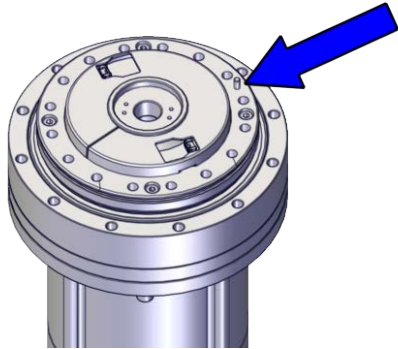
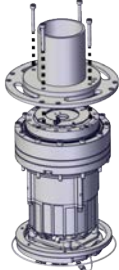
	Action	Note
2	<p>Check the o-ring. Replace if damaged.</p>	<p>O-ring: 3HAC061327-036</p>  <p>xx2300000836</p>
3	<p>Fit two guide pins to the housing.</p>	<p>Guide pin, M4x120: 3HAC077786-001</p> <p>Always use guide pins in pairs.</p> <p>For joint units on axes 1, 2 and 3 of CRB 15000-5/0.95 and axis 3 of CRB 15000-10/1.52 and CRB 15000-12/1.27.</p>  <p>xx2300000803</p>
4	<p>Fit the lifting aid to the joint unit, aligning the pin with the pin hole.</p> <p> CAUTION</p> <p>The connectors and the joint unit cables are sensitive to mechanical damage. Handle the assembly with care.</p>  <p>xx2300000777</p>	<p>Joint unit: 3HAC087474-001</p> <p>Lifting aid: 3HAC087788-001</p> <p>Screws: M4x30 (4 pcs)</p>  <p>xx2300000804</p>

Continues on next page

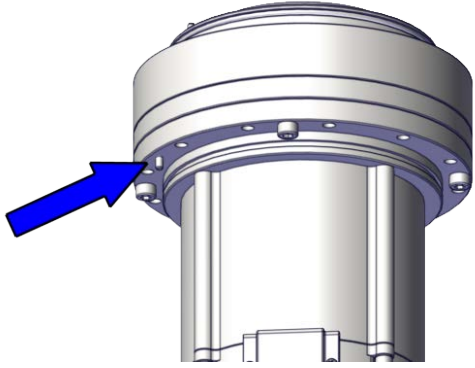
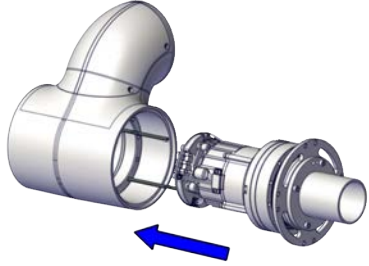
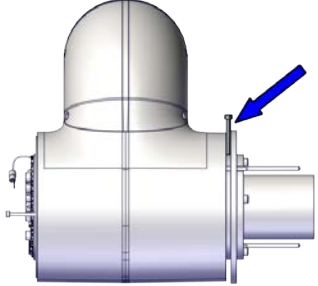
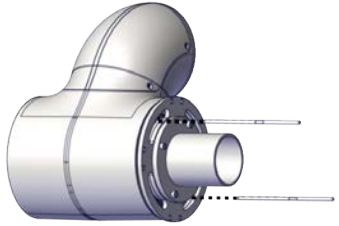
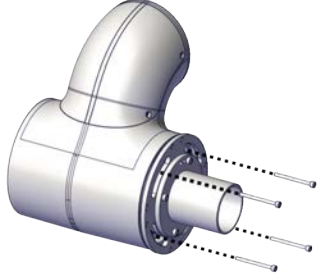
	Action	Note
5	<p>Fit the joint unit to the housing, aligning the pin with the pin hole.</p> <p> CAUTION</p> <p>The connectors and the joint unit cables are sensitive to mechanical damage. Handle the assembly with care.</p>  <p>xx2300000780</p>	 <p>xx2300000806</p>
6	<p>Check the joint unit position by placing an M4 screw between the lifting aid and housing. The joint unit is properly placed when no gaps between the lifting aid and housing.</p>	 <p>xx2300000808</p>
7	<p>Remove the guide pins.</p>	 <p>xx2300000809</p>
8	<p>Secure with four attachment screws and pre-tighten the screws crosswise.</p>	 <p>xx2300000810</p>

Continues on next page

5 Repair

5.6.5 Replacing the axis-3 joint unit

Continued

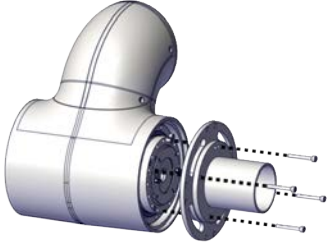
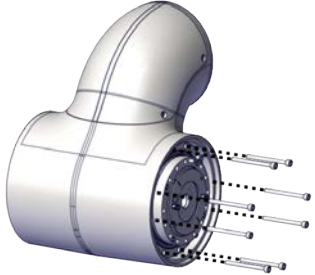
	Action	Note
9	Remove the lifting aid by removing the screws.	 <p>xx2300000800</p>
10	Secure the joint unit with the remaining attachment screws.	<p>Hex socket head cap screw: 3HAB3409-262</p>  <p>xx2300000811</p>
11	Torque tighten all screws crosswise.	<p>M4x45 12.9 Lafre 2C2B/FC6.9, 12 pcs Tightening torque: 4.3 Nm.</p>

Connecting the axis-3 joint unit cabling

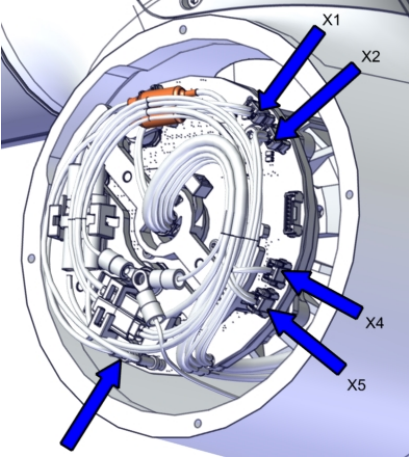
	Action	Note
1	<p>Reconnect the connectors to the drive board.</p> <ul style="list-style-type: none"> • D3.X1 to X1 • D3/4.DC+ to DC+ • D3/4.DC- to Ground • D3.X4 to X4 • D3/4.X2 to X2 • D3.X5 to X5 	 <p>xx2000002068</p>

Continues on next page

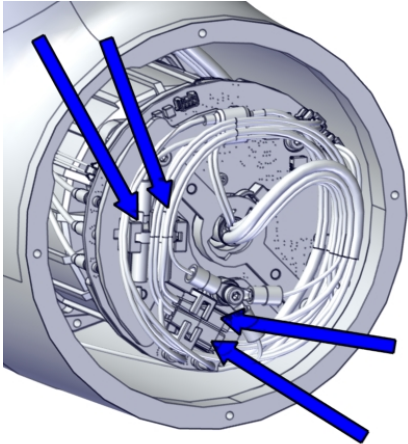
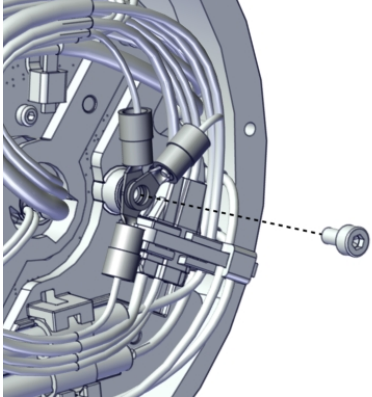
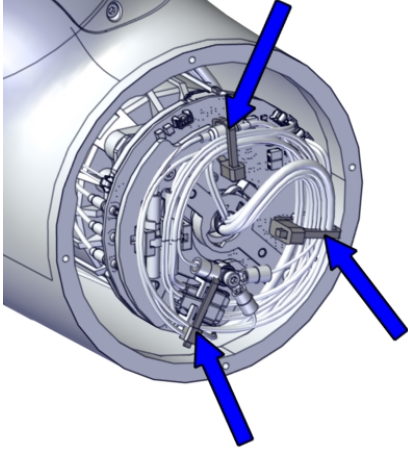
	Action	Note
2	<p>Connect the connectors to each other and snap them to the cable holders.</p> <ul style="list-style-type: none"> • J4.DC+ to J4/5.DC+ • J4.DC- to J4/5.DC- • J4.CS to J4/5.CS • J4.CP to J4/5.CP 	 <p>xx2000002067</p>
3	<p>Secure the cables for functional earth and protective earth with a screw.</p>	<p>Hex socket head cap screw: M3x6 (1 pcs). Tightening torque: 0.8 Nm.</p>  <p>xx2000001945</p>
4	<p>Secure the cabling with cable ties.</p>	<p>Cable ties (3 pcs)</p>  <p>xx2000002066</p>

Continues on next page

5 Repair

5.6.5 Replacing the axis-3 joint unit

Continued

Refitting the housing cover (-5/0.95)

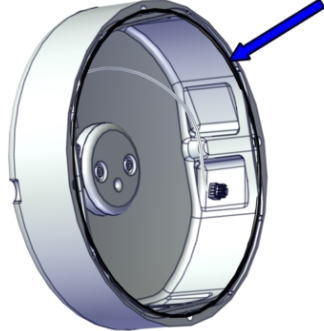
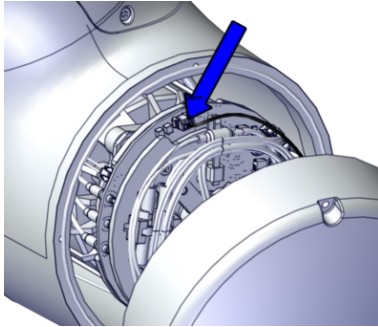
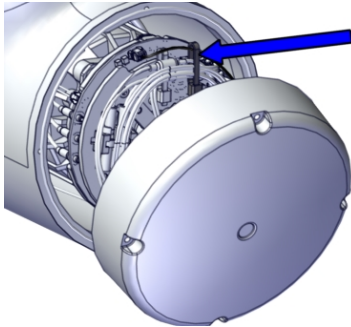
	Action	Note
1	Fit the o-ring to its groove. Replace if damaged.	O-ring: 3HAC061327-047  xx2000001962
2	For robots with RobotWare earlier than 7.10 Place the cover at mounting position and reconnect the brake release connector DR.X8 to the drive board. Orient the cover for proper arrangement of the brake release cable.	 xx2000002023
3	For robots with RobotWare earlier than 7.10 Secure the brake release cable with a cable tie.	Cable ties  xx2000002022

Continues on next page

5.6.5 Replacing the axis-3 joint unit

Continued

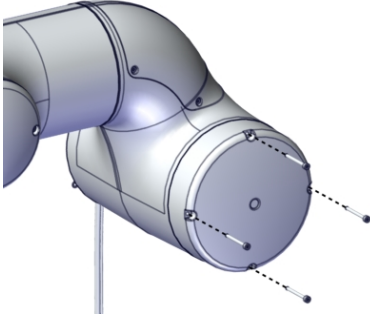
	Action	Note
4	Refit the cover with the four screws.	<p>Hex socket head cap screw: M3x30 12.9 Lafre 2C2B/FC6.9 (4 pcs) Tightening torque: 0.45 Nm</p>  <p>xx2000002021</p>

Refitting the housing cover and insert (-10/1.52 and -12/1.27)

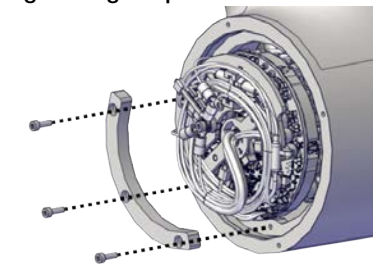
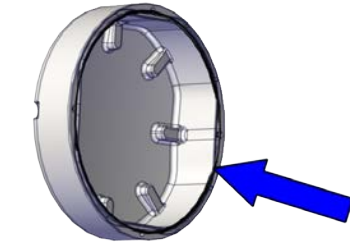
	Action	Note
1	Refit the insert.	<p>Insert: 3HAC084002-001 Hex socket head cap screw: M3x10 12.9 Lafre 2C2B/FC6.9 (3 pcs) Tightening torque: 1.4 Nm</p>  <p>xx2300000834</p>
2	Fit the o-ring to its groove. Replace if damaged.	<p>O-ring: 3HAC061327-047</p>  <p>xx2300000835</p>

Continues on next page

5 Repair

5.6.5 Replacing the axis-3 joint unit

Continued

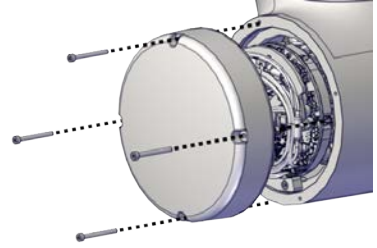
	Action	Note
3	Refit the cover with the four screws.	<p>Hex socket head cap screw: M3x30 12.9 Lafre 2C2B/FC6.9 (4 pcs) Tightening torque: 1.4 Nm</p>  <p>xx2300000833</p>

Refitting the upper arm

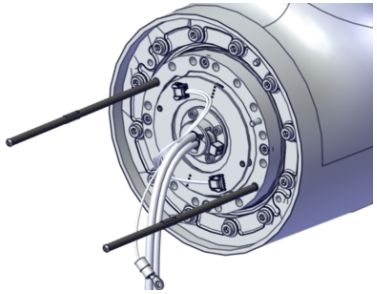
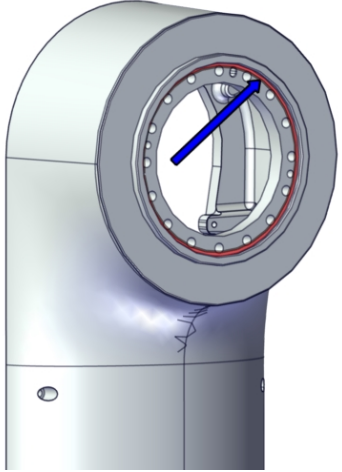
	Action	Note
1	Fit two guide pins to the axis-3 joint.	<p>Guide pin, M4x120: 3HAC077786-001</p>  <p>xx2000001971</p>
2	<p>Valid for CRB 15000-5/0.95 Clean the mounting surface with isopropanol. Apply flange sealant to the corner of the lower arm mounting surface, as pointed out in the figure.</p>	<p>Cleaning agent: Isopropanol Flange sealant: Loctite 574</p>  <p>xx2000001973</p>

Continues on next page

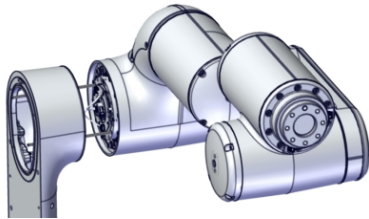
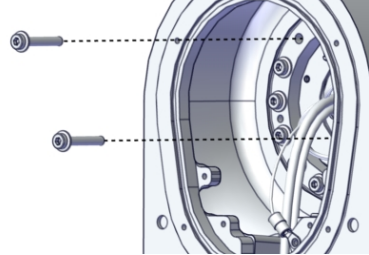
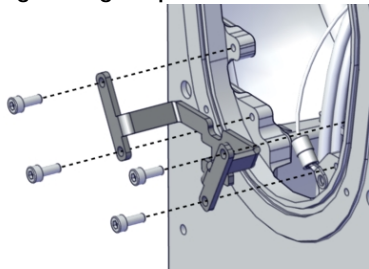
	Action	Note
3	Lift the upper arm into mounting position while inserting the cabling into the lower arm.	 <p data-bbox="1058 533 1166 551">xx2000001970</p>
4	Slide the upper arm into place on the guide pins.	
6	Remove the guide pins and fasten the remaining two screws.	<p data-bbox="1058 954 1441 1039">Hex socket head cap flange screw: M4x25 12.9 Lafre 2C2B/FC6.9+PrO-COat111 (16 pcs)</p>  <p data-bbox="1058 1308 1166 1326">xx2000001967</p>
7	Torque tighten all screws crosswise.	Tightening torque: 4.6 Nm
8	Refit the cable bracket with the four screws.	<p data-bbox="1058 1406 1441 1464">Hex socket head cap screw: M3x8 12.9 Lafre 2C2B/FC6.9 (4 pcs).</p> <p data-bbox="1058 1471 1350 1489">Tightening torque: 0.8 Nm</p>  <p data-bbox="1058 1771 1166 1789">xx2000001966</p>

Continues on next page

5 Repair

5.6.5 Replacing the axis-3 joint unit

Continued

Fastening the cabling between the lower and upper arm

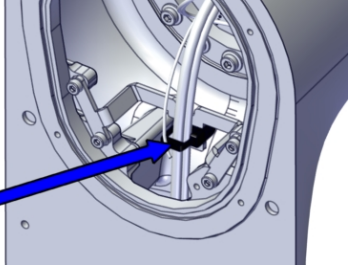
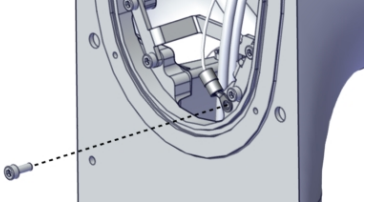
	Action	Note
1	Secure the cabling with the cable tie.	Cable ties  xx2000001965
2	Connect the functional earth cable with the screw.	Hex socket head cap screw: M3x8 12.9 Lafre 2C2B/FC6.9 (1 pcs). Tightening torque: 0.8 Nm  xx2000001964

Connecting the upper arm cabling

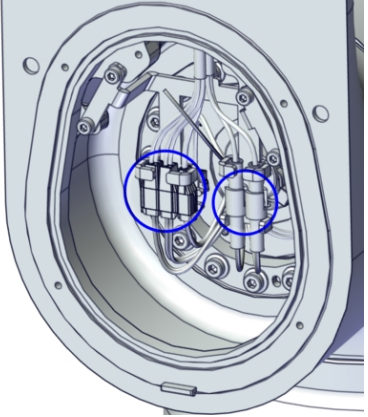
	Action	Note
1	Connect the connectors to each other and snap them to the cable holders.	 xx2000001938



Continues on next page

5.6.5 Replacing the axis-3 joint unit

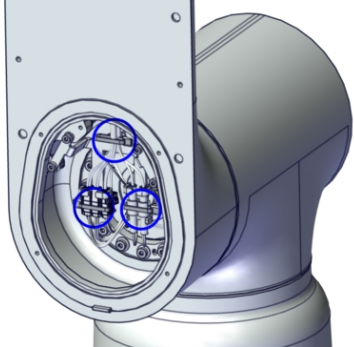
Continued

	Action	Note
2	Secure the cabling with cable ties.	<p>Cable ties (3 pcs)</p>  <p>xx2000001937</p>

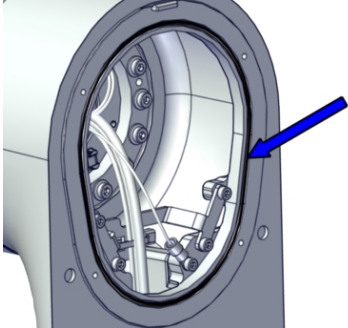
Refitting the lower arm covers (-5/0.95)

	Action	Note
1	Wipe, lubricate and fit the o-ring to its groove. Replace if damaged.	<p>O-ring: 3HAC061327-044 Grease: 3HAC042536-001 (Shell Gadus S2)</p>  <p>xx2000001955</p>  <p>xx2000001954</p>

Continues on next page

5 Repair

5.6.5 Replacing the axis-3 joint unit

Continued

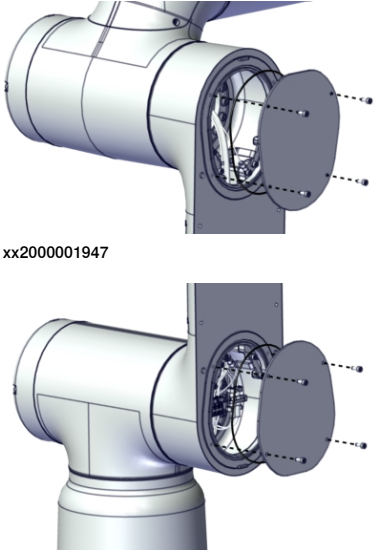
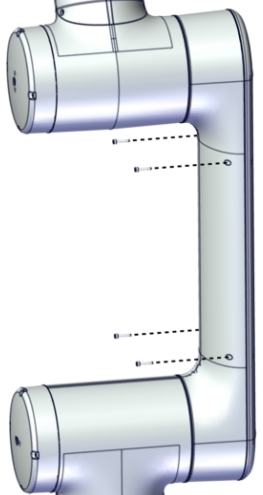
	Action	Note
2	Refit the inner covers with four screws each.	<p>Hex socket head cap screw: M3x8 12.9 Lafre 2C2B/FC6.9 (8 pcs) Tightening torque: 1.4 Nm.</p>  <p>xx2000001947</p> <p>xx2000001930</p>
3	Snap the lower arm cover into place.	<p>Hex socket head cap screw: M3x16 12.9 Lafre 2C2B/FC6.9 (4 pcs) Tightening torque: 0.45 Nm.</p>  <p>xx2000001929</p>
4	Secure the cover with four screws.	

Continues on next page

Refitting the lower arm covers (-10/1.52 and -12/1.27)

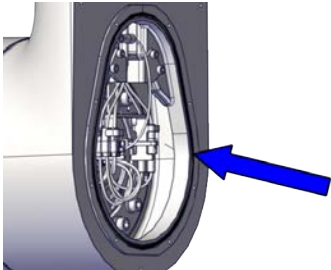
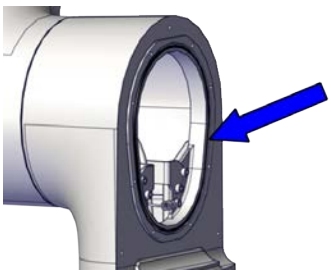
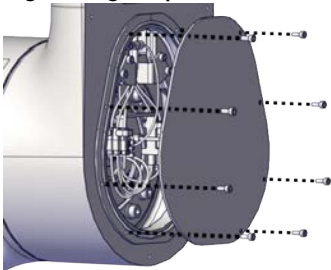
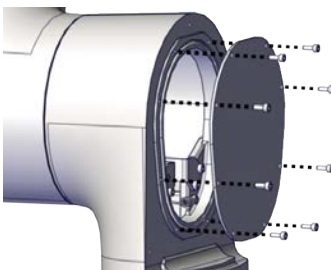
	Action	Note
1	Wipe, lubricate and fit the o-ring to its groove. Replace if damaged.	<p>O-ring: 3HAC061327-075 O-ring: 3HAC061327-044 Grease: 3HAC042536-001 (Shell Gadus S2)</p>  <p>xx2300000832</p>  <p>xx2300000831</p>
2	Refit the inner covers with eight screws each.	<p>Hex socket head cap screw: M3x8 12.9 Lafre 2C2B/FC6.9 (8 pcs) x 2 Tightening torque: 1.4 Nm.</p>  <p>xx2300000813</p>  <p>xx2300000830</p>

Continues on next page

5 Repair

5.6.5 Replacing the axis-3 joint unit

Continued

	Action	Note
3	Snap the lower arm cover into place.	Hex socket head cap screw: M3x12 12.9 Lafre 2C2B/FC6.9 (3 pcs) x 2 Tightening torque: 1.4 Nm.
4	Secure the cover with three screws.	

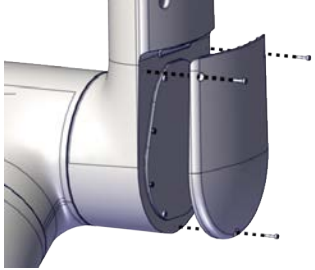
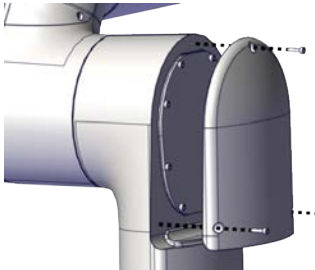
Concluding procedure

	Action	Note
1	Calibrate the joint unit torque sensor. <ol style="list-style-type: none"> 1 On the FlexPendant, go to the Code app and call the calibration procedure using PP to Routine, not by using Call Routine. 2 Select the Joint Unit Replacement feature and then select the axis to calibrate. 3 The controller is now restarted. Once the home screen of the FlexPendant is shown, press the Play button to continue the calibration routine. 4 The robot moves to a position or positions where measurements are performed. 5 The results of the measurements are presented together with the current values in the controller. Choose whether to save the calibration data or not. 6 If new calibration data is saved you will be asked to do a test with the lead-through functionality active to verify that the sensors work correctly. 7 Finally the robot is moved back to the original position. 8 Test the brake release (movement without drive power) functionality, see Testing the brake release functionality on page 196. 	See Calibration on page 1063

Continues on next page

	Action	Note
2	 DANGER Make sure all safety requirements are met when performing the first test run. See Test run after installation, maintenance, or repair on page 90 .	

5 Repair

5.6.6 Replacing the axis-4 joint unit

5.6.6 Replacing the axis-4 joint unit

Location of the axis-4 joint unit

The joint unit is located as shown in the figure.

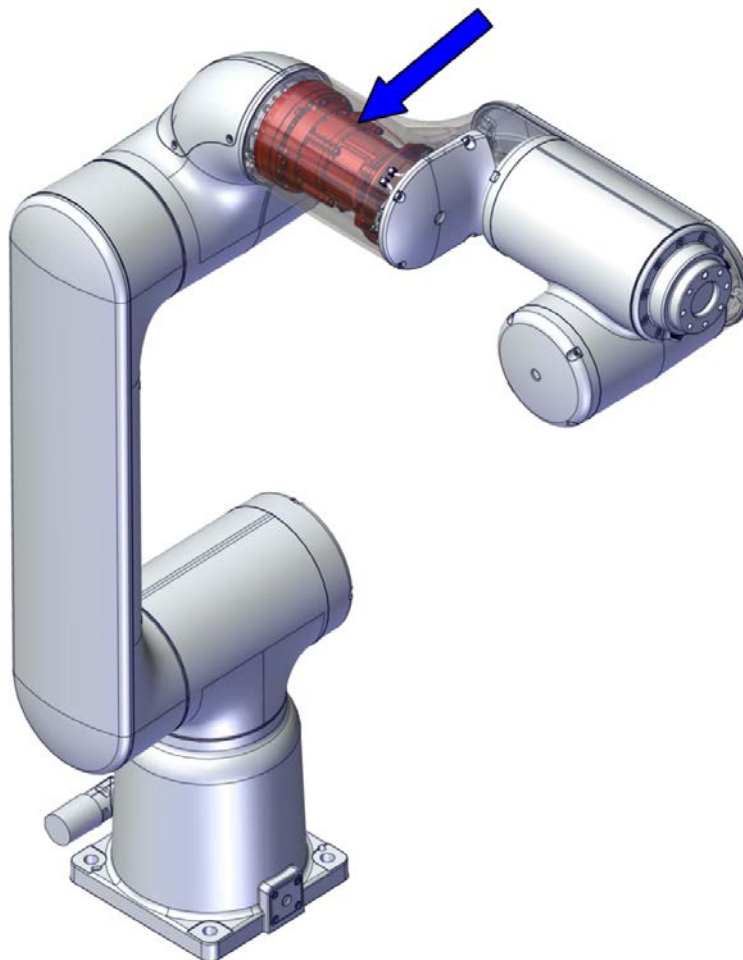

xx2000002119

Summary of the replacement procedure

This is a brief summary of the replacement procedure, containing the major actions to be performed.

- 1 Separate the cabling between the housing and the tubular (at the axis-3 joint unit).
- 2 Remove the tubular and place on a workbench.
- 3 Remove the axis-4 cover.
- 4 Replace the joint unit. Move the cabling from old to new joint unit.

Continues on next page

Required spare parts



Note

The spare part numbers that are listed in the table can be out of date. See the latest spare parts of the CRB 15000 via myABB Business Portal, www.abb.com/myABB.

Spare part	Article number	Note
Joint unit	3HAC079143-001	Used for CRB 15000-5/0.95. New attachment screws and cable tie 3HAC075545-001 are included in the delivery.
Joint unit	3HAC087546-001	New attachment screws and cable tie 3HAC075545-001 are included in the delivery.

Required tools and equipment

Equipment	Article number	Note
Lifting aid	3HAC077789-001	For joint units on axes 4, 5 and 6. Attachment screws M3x12 (4 pcs) are enclosed.
Guide pin, M3x110	3HAC077787-001	Always use guide pins in pairs. For joint units on axes 4, 5 and 6.
Protection plate	3HAC077790-001	For protection of drive board during cabling installation on joint units of CRB 15000-5/0.95.
Protection plate	3HAC087789-001	For protection of drive board during cabling installation on joint units of CRB 15000-10/1.52 and CRB 15000-12/1.27.
Cable tie gun EVO 7i	-	HellermannTyton 110-77001 or similar
Tweezers	-	Used to handle drive board connectors.
Standard toolkit	-	Content is defined in section Standard toolkit on page 1099 .

Required consumables

Consumable	Article number	Note
Cleaning agent	-	Isopropanol
Flange sealant	-	Loctite 574
Cable ties	-	
O-ring	3HAC061327-043	Tubular cover, used for CRB 15000-5/0.95. Replace if damaged.

Continues on next page

5 Repair

5.6.6 Replacing the axis-4 joint unit

Continued



Consumable	Article number	Note
Flange socket head screw with glue	3HAB3413-312	M3x12 12.9 Lafre 2C2B/FC6.9+PrO-COat111, with NYPLAS glue For tubular cover of CRB 15000-5/0.95. Always use new screws. If ordering a new axis-4 or axis-5 joint unit spare part, new screws for the tubular cover are included.
O-ring	3HAC061327-076	Tubular cover, lower, used for CRB 15000-10/1.52 and CRB 15000-12/1.27. Replace if damaged.
O-ring	3HAB3772-166	Tubular cover, upper, used for CRB 15000-10/1.52 and CRB 15000-12/1.27. Replace if damaged.
O-ring	3HAC061327-051	Axis-4 cover, used for CRB 15000-5/0.95. Replace if damaged.
O-ring	3HAC061327-051	Axis-4 cover, used for CRB 15000-10/1.52 and CRB 15000-12/1.27. Replace if damaged.
Gasket	3HAC075056-001	Cover inside housing Replace if damaged.
O-ring	3HAC061327-047	Cover for axis 2/3, used for CRB 15000-5/0.95. Replace if damaged.
O-ring	3HAC061327-047	Housing cover, used for CRB 15000-10/1.52 and CRB 15000-12/1.27. Replace if damaged.

Continues on next page

Removing the joint unit

Use these procedures to remove the joint unit.

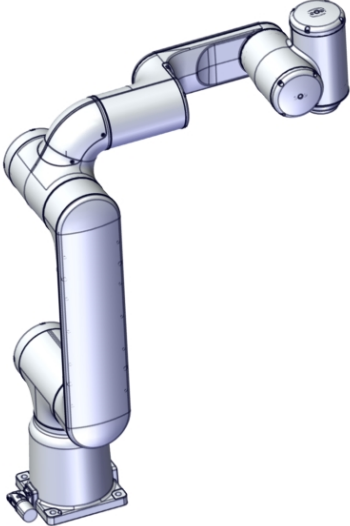
Preparations before removing the joint unit

	Action	Note
1	<p>Jog the robot to the specified position:</p> <ul style="list-style-type: none"> • Axis 1: No significance. • Axis 2: 0° • Axis 3: 0° • Axis 4: 0° (home position) • Axis 5: +90° • Axis 6: No significance. <p> CAUTION</p> <p>Jog the axis on which the joint unit is to be replaced to home position, to achieve correct cable routing during replacement of the joint unit.</p>	<p>Example of CRB 15000-5/0.95, similar to CRB 15000-10/1.52 and CRB 15000-12/1.27.</p>  <p>xx2100000005</p>
2	<p> CAUTION</p> <p>Turn off all supplies for electrical power to the robot, before starting the repair work.</p>	

Removing the housing cover (-5/0.95)

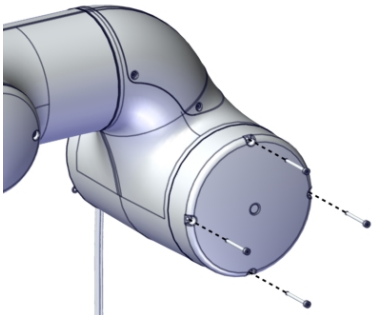
	Action	Note
1	<p> CAUTION</p> <p>Make sure that all supplies for electrical power are turned off.</p>	
2	<p>Remove the cover screws.</p>	 <p>xx2000002021</p>

Continues on next page

5 Repair

5.6.6 Replacing the axis-4 joint unit

Continued

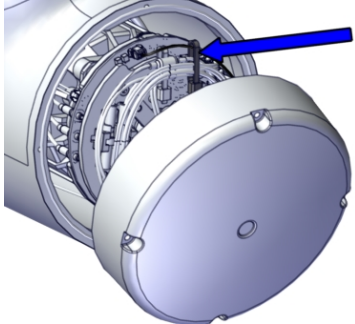
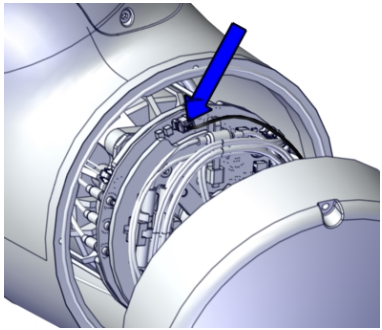
	Action	Note
3	 CAUTION Valid for CRB 15000-5/0.95 There is cabling connected between the cover and the joint unit drive board. Open the cover with care to avoid damage to the cabling or the connector(s). Do not leave the cover in location without being secured with the attachment screws.	
4	For robots with RobotWare earlier than 7.10 Open the cover and cut the cable tie that holds the brake release cable.	 <small>xx2000002022</small>
5	For robots with RobotWare earlier than 7.10 Disconnect the brake release connector DR.X8 from the drive board. Remove the cover.	 <small>xx2000002023</small>

Removing the housing cover and insert (-10/1.52 and -12/1.27)

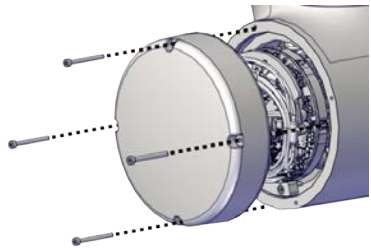
	Action	Note
1	 CAUTION Make sure that all supplies for electrical power are turned off.	
2	Remove the cover by removing the screws.	 <small>xx2300000833</small>

Continues on next page

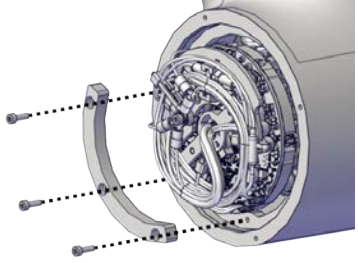
	Action	Note
3	<p> CAUTION</p> <p>Valid for CRB 15000-5/0.95</p> <p>There is cabling connected between the cover and the joint unit drive board.</p> <p>Open the cover with care to avoid damage to the cabling or the connector(s).</p> <p>Do not leave the cover in location without being secured with the attachment screws.</p>	
4	Remove the insert.	 <p>xx2300000834</p>

Separating the cabling between the housing and the tubular

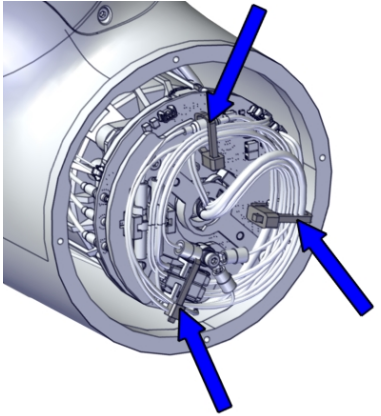
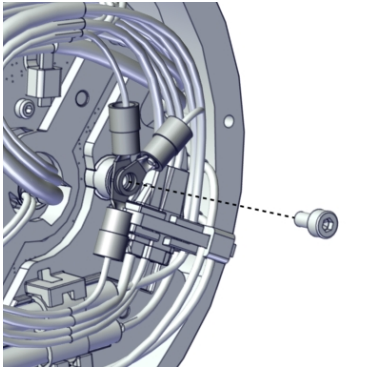
	Action	Note
1	Cut the cable ties.	 <p>xx2000002066</p>
2	Remove the functional and protective earth cables by removing the screw.	 <p>xx2000001945</p>

Continues on next page

5 Repair

5.6.6 Replacing the axis-4 joint unit

Continued

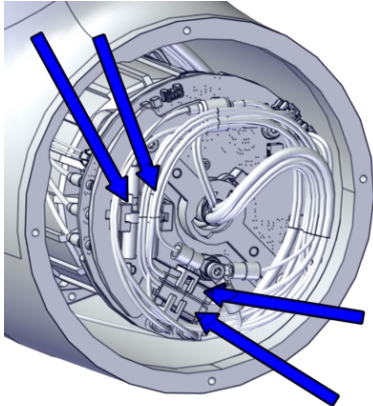
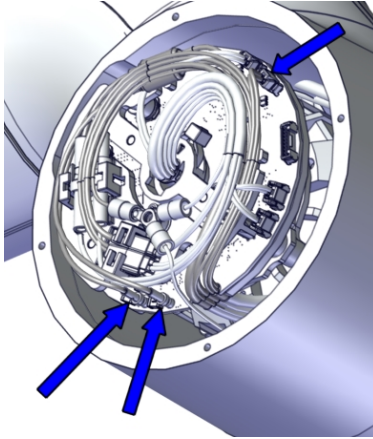
	Action	Note
3	<p>Snap loose and disconnect the connectors:</p> <ul style="list-style-type: none">• J4/5.DC+• J4/5.DC-• J4/5.CS• J4/5.CP	 <p>xx2000002067</p>
4	<p>Disconnect the connectors from the drive board.</p> <ul style="list-style-type: none">• D3/4.X2• D3/4.DC+• D3/4.DC-	 <p>xx2000002120</p>

Opening the housing top cover

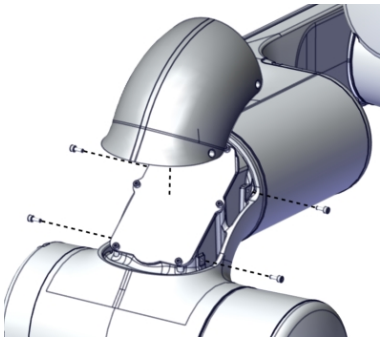
	Action	Note
1	<p>Remove the cover by removing the four screws.</p>	 <p>xx2000002075</p>

Continues on next page

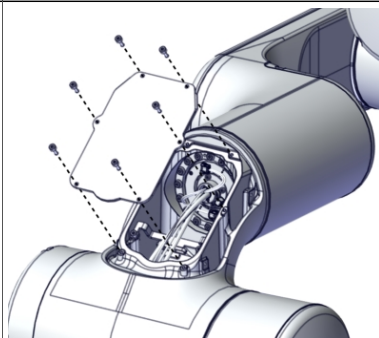
	Action	Note
2	Remove the inner plate by removing the screws.	 <p>xx2000002076</p>

Removing the tubular

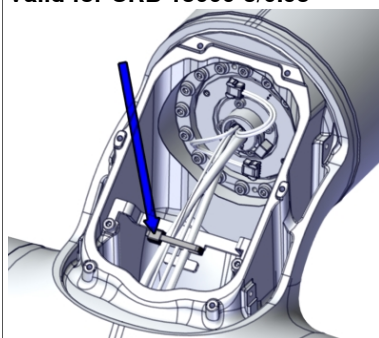
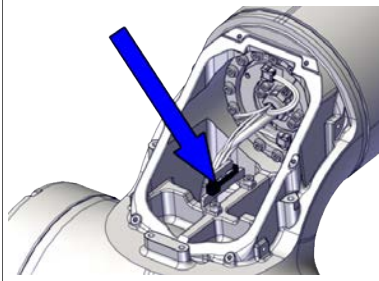
	Action	Note
1	Cut the cable tie.	<p>Valid for CRB 15000-5/0.95</p>  <p>xx2000002077</p> <p>Valid for CRB 15000-10/1.52 and CRB 15000-12/1.27</p>  <p>xx2300000839</p>

Continues on next page

5 Repair

5.6.6 Replacing the axis-4 joint unit

Continued

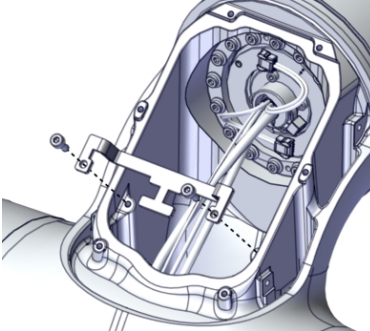
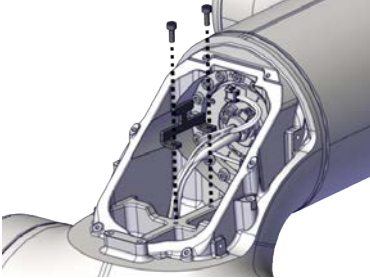
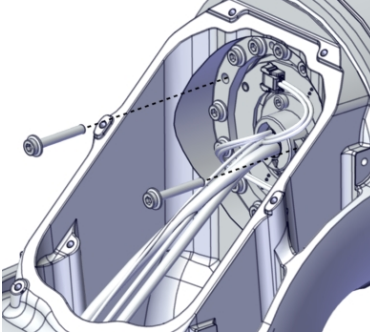
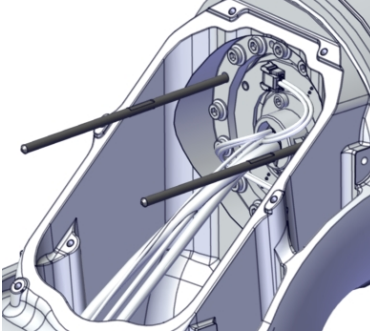
	Action	Note
2	Remove the cable bracket by removing the two screws.	<p>Valid for CRB 15000-5/0.95</p>  <p>xx2000002078</p> <p>Valid for CRB 15000-10/1.52 and CRB 15000-12/1.27</p>  <p>xx2300000840</p>
3	Remove two attachment screws and fit two guide pins to the axis-4 joint unit.	<p>Guide pin, M3x110: 3HAC077787-001 Always use guide pins in pairs.</p>  <p>xx2000002079</p>  <p>xx2000002080</p>

Continues on next page

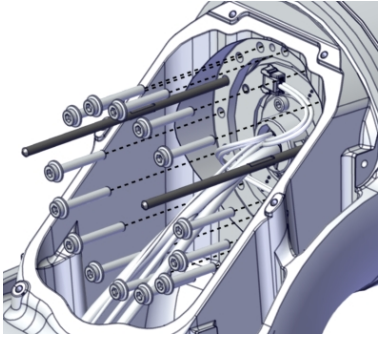
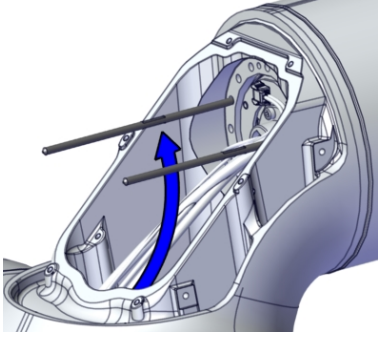
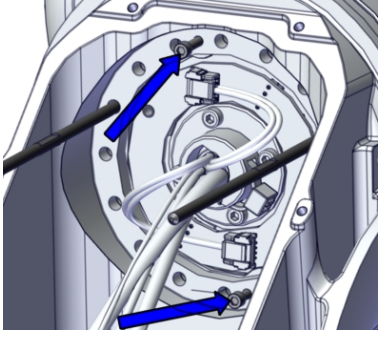
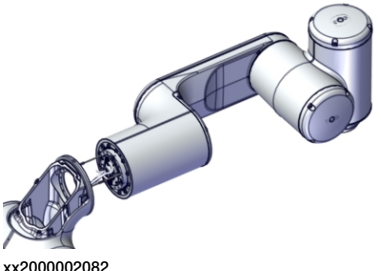
	Action	Note
4	Remove the remaining attachment screws.	 <p>xx2000002081</p>
5	Pull out the cabling carefully from the housing.	 <p>xx2000002127</p>
6	Use two fully threaded attachment screws as removal tools to press the housing out of position.	 <p>xx2100000006</p>
7	Remove the tubular from the housing. Assist the cabling to be removed from the housing while lifting away the complete tubular. Place the tubular on a workbench.	 <p>xx2000002082</p>



Continues on next page

5 Repair

5.6.6 Replacing the axis-4 joint unit

Continued

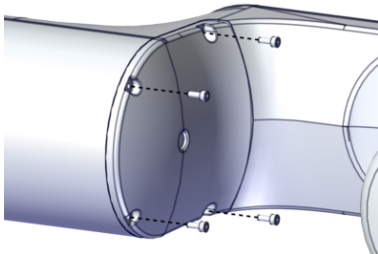
Removing the axis-4 cover

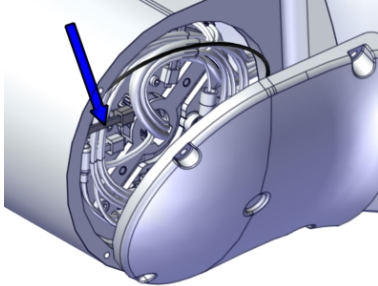
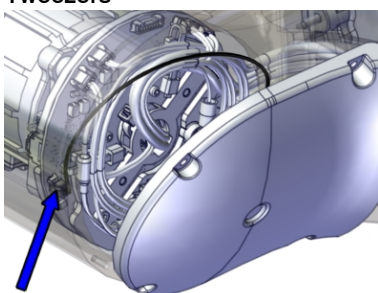
	Action	Note
1	Remove the cover screws.	 <p>xx2000002083</p>
2	<p> CAUTION</p> <p>Valid for CRB 15000-5/0.95</p> <p>There is cabling connected between the cover and the joint unit drive board.</p> <p>Open the cover with care to avoid damage to the cabling or the connector(s).</p> <p>Do not leave the cover in location without being secured with the attachment screws.</p>	
3	<p>For robots with RobotWare earlier than 7.10</p> <p>Open the cover and cut the cable tie that holds the brake release cable.</p>	 <p>xx2000002084</p>
4	<p>For robots with RobotWare earlier than 7.10</p> <p>Disconnect the brake release connector DR.X8 from the drive board.</p> <p>Remove the cover.</p>	<p>Tweezers</p>  <p>xx2000002085</p>

Continues on next page

Removing the tubular cover

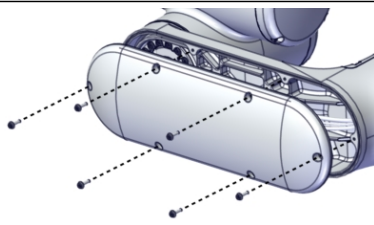
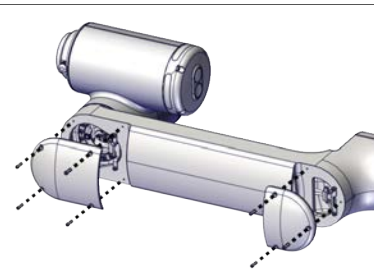
	Action	Note
1	<p>Valid for CRB 15000-5/0.95</p> <p>Remove the cover by removing the six screws. Dispose the screws. New screws must be used when refitting the cover. New screws are included in the spare part delivery of the joint unit.</p>	 <p>xx2000002123</p>
2	<p>Valid for CRB 15000-10/1.52 and CRB 15000-12/1.27</p> <p>Remove the covers by removing the screws.</p>	 <p>xx2300000841</p>

Separating the cabling between the tubular and the tilt

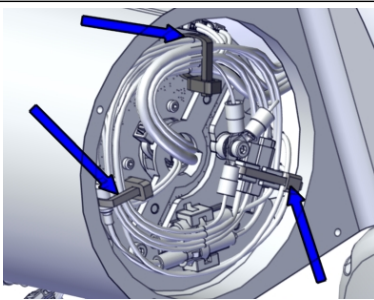
	Action	Note
1	<p>Cut the cable ties on joint unit.</p>	 <p>xx2000002086</p>

Continues on next page

5 Repair

5.6.6 Replacing the axis-4 joint unit

Continued

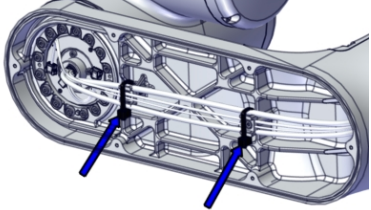
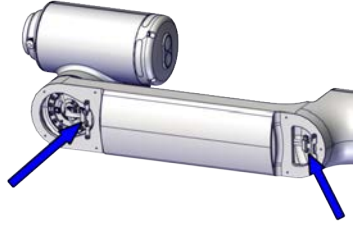
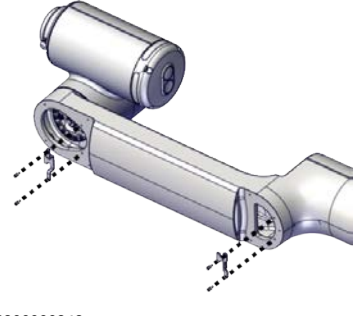
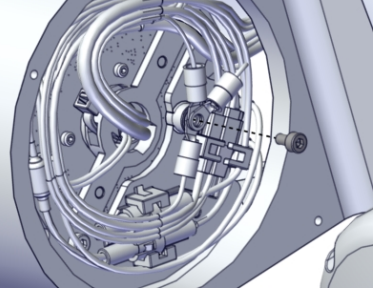
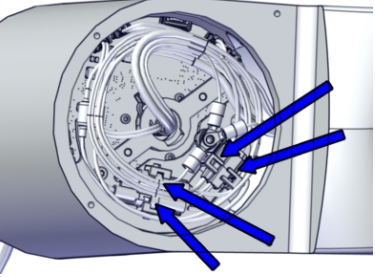
	Action	Note
2	Cut the cable ties on tubular, if needed.	<p>Valid for CRB 15000-5/0.95</p>  <p>xx2000002124</p> <p>Valid for CRB 15000-10/1.52 and CRB 15000-12/1.27</p>  <p>xx2300000842</p>
3	<p>Valid for CRB 15000-10/1.52 and CRB 15000-12/1.27</p> <p>Remove the cable brackets.</p>	 <p>xx2300000843</p>
4	Remove the functional and protective earth cables by removing the screw.	 <p>xx2000002087</p>
5	<p>Snap loose and disconnect the connectors:</p> <ul style="list-style-type: none"> • J4/5.DC+ • J4/5.DC- • J4/5.CS • J4/5.CP 	 <p>xx2000002089</p>

Continues on next page

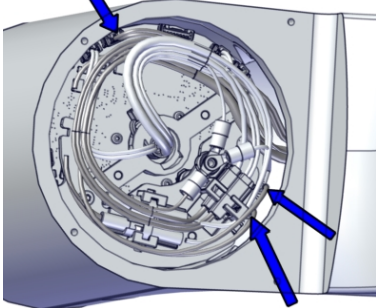
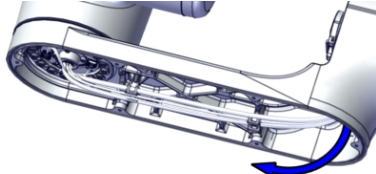
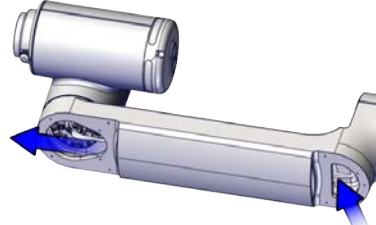
	Action	Note
6	<p>Disconnect the connectors that belongs to the axis-5 cabling, from the axis-4 drive board:</p> <ul style="list-style-type: none"> • D3/4.X2 • D3/4.DC- • D3/4.DC+ <p>Use tweezers, if needed.</p>	<p>Tweezers</p>  <p>xx2000002125</p>
7	<p>Pull out the cabling carefully from the tubular.</p>	<p>Valid for CRB 15000-5/0.95</p>  <p>xx2000002126</p> <p>Valid for CRB 15000-10/1.52 and CRB 15000-12/1.27</p>  <p>xx2300000844</p>

Disconnecting the axis-4 joint unit cabling

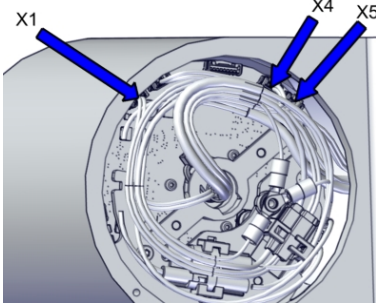
	Action	Note
1	<p>Disconnect the connectors from the drive board.</p> <p> CAUTION</p> <p>Use tweezers to unlock connectors and pull them off.</p> <ul style="list-style-type: none"> • D4/5.X1 • D4/5.X4 • D4/5.X5 	<p>Tweezers</p>  <p>xx2000002088</p>

Continues on next page

5 Repair

5.6.6 Replacing the axis-4 joint unit

Continued

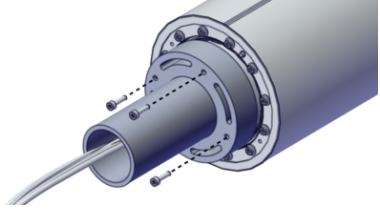
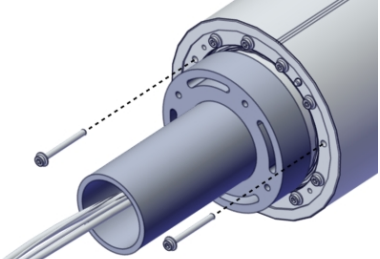
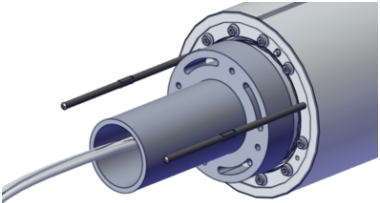
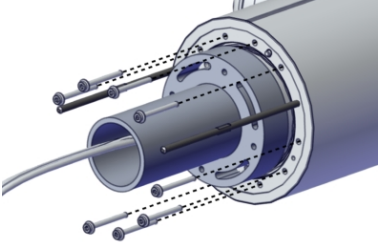
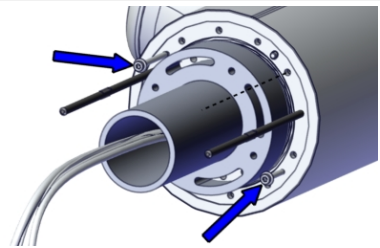

Removing the axis-4 joint unit

	Action	Note
1	<p>Fit the lifting aid to the joint unit, on the torque sensor side.</p> <p> CAUTION</p> <p>The connectors and the joint unit cables are sensitive to mechanical damage. Handle the assembly with care.</p>	<p>Lifting aid: 3HAC077789-001 Screws: M3x12 (4 pcs)</p>  <p>xx2000002090</p>
2	<p>Remove two attachment screws. Dispose the screws. New screws are included in the spare part delivery of the joint unit.</p>	 <p>xx2000002091</p>
3	<p>Fit two guide pins to the axis-4 joint unit.</p>	<p>Guide pin, M3x110: 3HAC077787-001 Always use guide pins in pairs. For joint units on axes 4, 5 and 6.</p>  <p>xx2000002578</p>
4	<p>Remove the remaining attachment screws. Use two screws as press out screws in the upcoming step, then dispose all screws. New screws are included in the spare part delivery of the joint unit.</p>	 <p>xx2100000326</p>
5	<p>Press the joint unit out of position using two of the previous attachment screws as removal tools.</p>	 <p>xx2100000327</p>

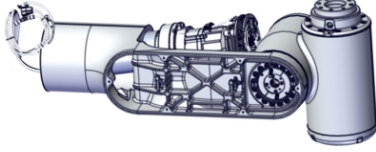
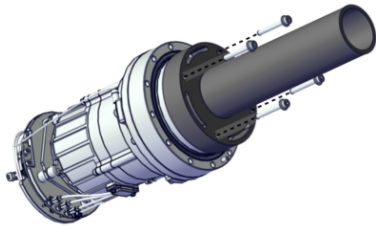
Continues on next page

	Action	Note
6	<p>Remove the joint unit from the tubular.</p> <p> CAUTION</p> <p>The connectors and the joint unit cables are sensitive to mechanical damage. Handle the assembly with care.</p>	 <p>xx2000002116</p>
7	<p>Remove the lifting aid and guide pins.</p>	 <p>xx2000001957</p>

Removing the joint cable

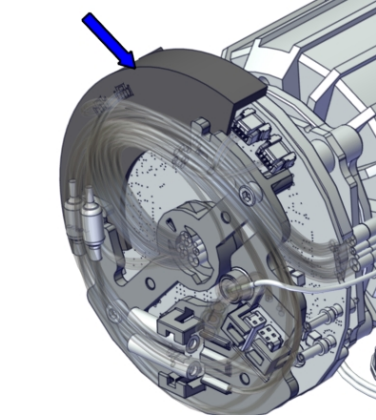
	Action	Note
1	<p> ELECTROSTATIC DISCHARGE (ESD)</p> <p>The unit is sensitive to ESD. Before handling the unit read the safety information in section The unit is sensitive to ESD on page 53.</p>	
2	<p>Fit the protection plate to the drive board unit.</p> <p> Tip</p> <p>Using the protection plate is important for protecting the drive board unit. If complete joint unit is to be replaced, the protection plate is not needed.</p>	<p>Protection plate: 3HAC077790-001 (for CRB 15000-5/0.95) / 3HAC087789-001 (for CRB 15000-10/1.52 and CRB 15000-12/1.27)</p>  <p>xx2000002057</p>

Continues on next page

5 Repair

5.6.6 Replacing the axis-4 joint unit

Continued

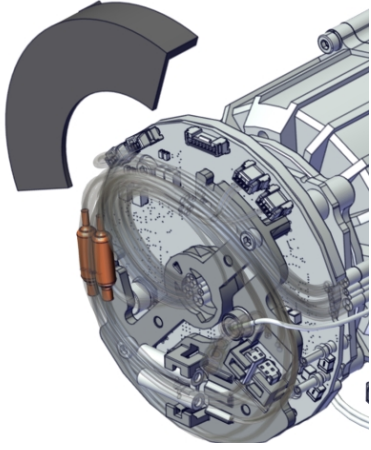
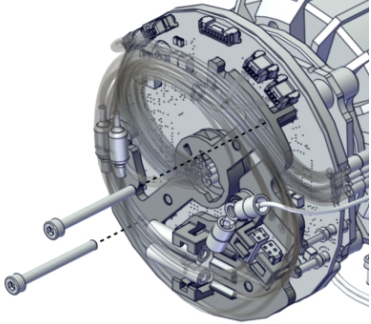
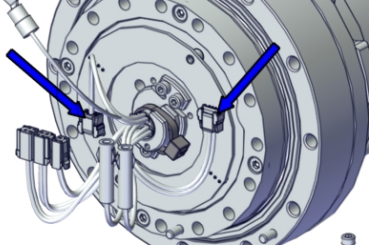
	Action	Note
3	Cut the cable tie at the drive board.	 xx2000002058
4	Remove the protection plate.	 xx2100000301
5	Remove the cable support from the drive board by removing the attachment screws.	 xx2000002055
6	Disconnect the two connectors from the torque sensor board. <ul style="list-style-type: none">• TQ.A• TQ.B	 xx2000002053

Continues on next page

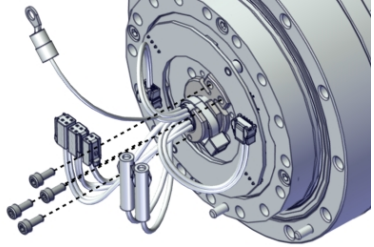
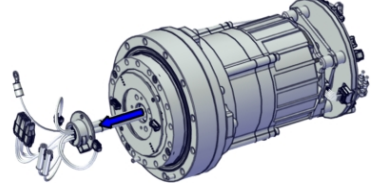
	Action	Note
7	Remove the cable plate by removing the attachment screws.	 <p data-bbox="1066 564 1166 584">xx2000002049</p>
8	<p data-bbox="512 622 1046 678">Remove the joint cable from the hollow shaft from the torque sensor side.</p> <p data-bbox="512 696 715 741">CAUTION</p> <p data-bbox="512 763 1046 846">The connectors and the joint unit cables are sensitive to mechanical damage. Handle the assembly with care.</p>	 <p data-bbox="1066 815 1166 835">xx2000002060</p>

Refitting the joint unit

Use these procedures to refit the joint unit.

Refitting the joint cable

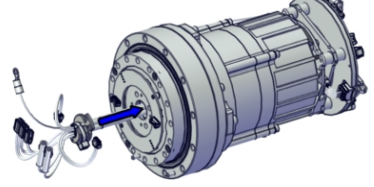
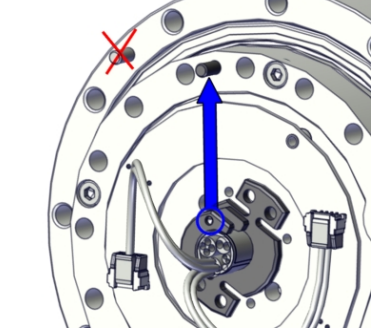
	Action	Note
1	<p data-bbox="512 1115 1046 1171">ELECTROSTATIC DISCHARGE (ESD)</p> <p data-bbox="512 1205 1046 1288">The unit is sensitive to ESD. Before handling the unit read the safety information in section The unit is sensitive to ESD on page 53.</p>	
2	<p data-bbox="512 1323 1046 1379">Place the joint cable through the hollow shaft from the torque sensor side.</p> <p data-bbox="512 1397 715 1442">CAUTION</p> <p data-bbox="512 1464 1046 1547">The connectors and the joint unit cables are sensitive to mechanical damage. Handle the assembly with care.</p>	 <p data-bbox="1066 1516 1166 1536">xx2000002048</p>
3	<p data-bbox="512 1581 1046 1664">Orient the cable plate according to the figure. The circle on the cable plate should point towards the guide pin on the torque sensor.</p>	 <p data-bbox="1066 1917 1166 1937">xx2000002051</p>

Continues on next page

5 Repair

5.6.6 Replacing the axis-4 joint unit

Continued

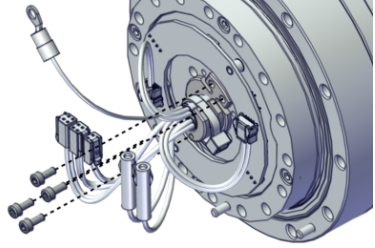
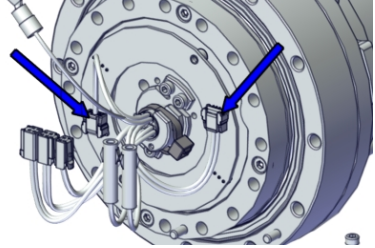
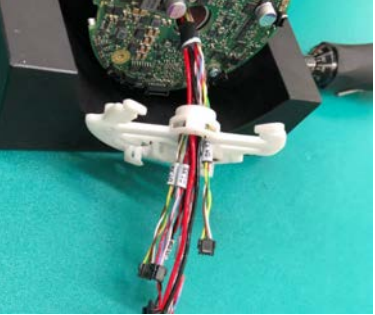
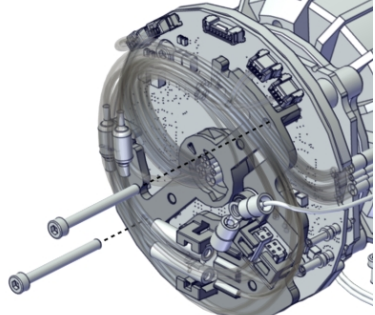
	Action	Note
4	Secure the cable plate to the joint unit with the attachment screws.	<p>Hex socket head cap screw: M2.5x6 12.9 Lafre 2C2B/FC6.9 (4 pcs) Tightening torque: 0.45 Nm.</p>  <p>xx2000002049</p>
5	Connect the two connectors to the torque sensor board. <ul style="list-style-type: none">• TQ.A to CH1/A• TQ.B to CH2/B	 <p>xx2000002053</p>
6	Insert the cabling through the cable support and fit the support to the drive board with the attachment screws.	 <p>xx2000002056</p> <p>Hex socket head cap screw: M3x30 12.9 Lafre 2C2B/FC6.9 (2 pcs) Tightening torque: 0.45 Nm.</p>  <p>xx2000002055</p>

Continues on next page

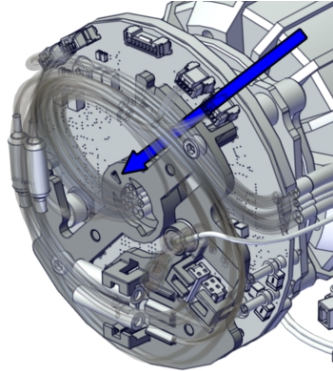
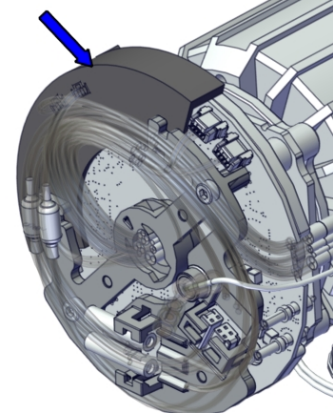
	Action	Note
7	<p>Keep the cabling loose, making sure not to twist or strain it. Use the cable tie to pre-fix the cable by hand.</p>	 <p>xx2100000507</p>
8	<p>Fit the protection plate to the drive board unit.</p>	<p>Protection plate: 3HAC077790-001 (for CRB 15000-5/0.95) / 3HAC087789-001 (for CRB 15000-10/1.52 and CRB 15000-12/1.27)</p>  <p>xx2000002057</p>

Continues on next page

5 Repair

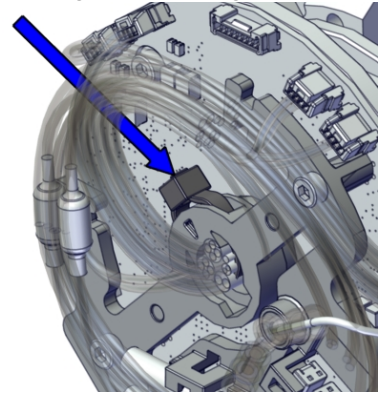
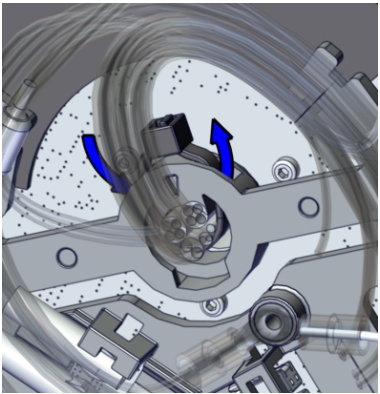
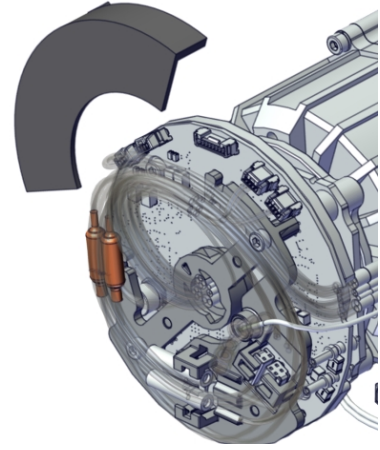

5.6.6 Replacing the axis-4 joint unit

Continued

	Action	Note
9	<p>Secure the cables to the cable support with a cable tie, using a cable tie gun.</p> <p>Assembly direction for the cable tie is shown in the figure.</p>	<p>Cable tie: 3HAC075545-001. For securing joint unit cable.</p> <p>Cable tie gun EVO 7i</p> <p>Setting for cable tie gun: 6.75.</p>  <p>xx200002058</p>  <p>xx200002059</p>
10	<p>Remove the protection plate.</p>	 <p>xx210000301</p>

Continues on next page

Preparations before fitting the joint unit

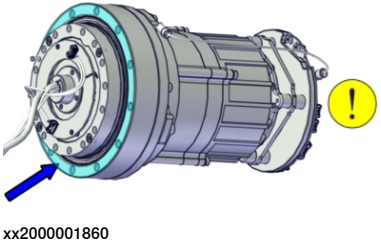
	Action	Note
1	 ELECTROSTATIC DISCHARGE (ESD) The unit is sensitive to ESD. Before handling the unit read the safety information in section <i>The unit is sensitive to ESD on page 53</i> .	
2	Clean the mounting surface of the joint unit and the mating surface on the casting with isopropanol. Joint unit mounting surface is pointed out in the figure.	Cleaning agent: Isopropanol Flange sealant: Loctite 574
3	Apply a thin layer of flange sealant to the mounting surface. Do not contaminate the radial sealing with sealant.  CAUTION The connectors and the joint unit cables are sensitive to mechanical damage. Handle the assembly with care.  ELECTROSTATIC DISCHARGE (ESD) The unit is sensitive to ESD. Before handling the unit read the safety information in section <i>The unit is sensitive to ESD on page 53</i> .	 <p>xx2000001860</p>

Refitting the axis-4 joint unit



	Action	Note
1	 CAUTION Axis-4 joint unit used for CRB 15000-5/0.95 has the same appearance as that used for CRB 15000-10/1.52 and CRB 15000-12/1.27. Do not mix the joint units for different manipulator variants. Always check the mark or label on the joint units before refitting.	

Continues on next page

5 Repair

5.6.6 Replacing the axis-4 joint unit

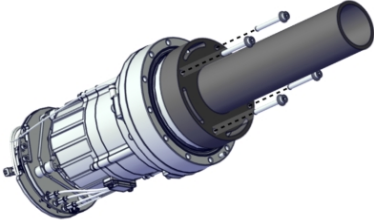
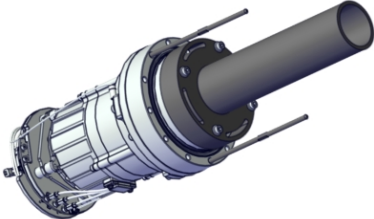
Continued

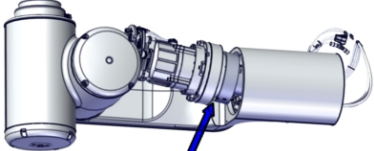
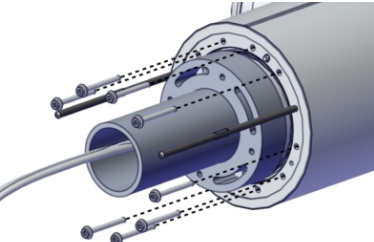
	Action	Note
2	<p>Fit the lifting aid to the joint unit.</p> <p> CAUTION</p> <p>The connectors and the joint unit cables are sensitive to mechanical damage. Handle the assembly with care.</p>	<p>Joint unit: 3HAC079143-001 (for CRB 15000-5/0.95) / 3HAC087546-001 (for CRB 15000-10/1.52 and CRB 15000-12/1.27)</p> <p>Lifting aid: 3HAC077789-001</p> <p>Screws: M3x12 (4 pcs)</p>  <p>xx2000001957</p>
3	<p>Fit two guide pins to the joint unit.</p>	<p>Guide pin, M3x110: 3HAC077787-001</p> <p>Always use guide pins in pairs.</p> <p>For joint units on axes 4, 5 and 6.</p>  <p>xx2000002438</p>
4	<p>Fit the joint unit to the tubular, aligning the pin with the pin hole.</p> <p> CAUTION</p> <p>The connectors and the joint unit cables are sensitive to mechanical damage. Handle the assembly with care.</p>	 <p>xx2000002117</p>
5	<p>Secure the joint unit with new attachment screws.</p>	<p>Flange socket head screw with glue: 3HAB3413-330</p> <p>M3x30 12.9 Lafre</p> <p>2C2B/FC6.9+PrO-COat111, with NYPLAS glue , 12 pcs</p> <p>Always use new screws when refitting a joint unit. If ordering a new joint unit spare part, new screws are included.</p>  <p>xx2100000326</p>

Continues on next page

5.6.6 Replacing the axis-4 joint unit
Continued

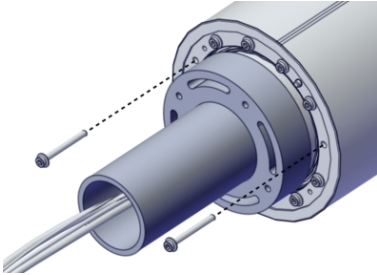
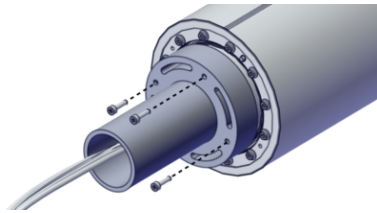
	Action	Note
6	Remove the guide pins and secure the remaining two attachment screws.	 <p>xx2000002091</p>
7	Pre-tighten the screws crosswise.	
8	Torque tighten all screws crosswise.	Tightening torque: 1.4 Nm (for CRB 15000-5/0.95) / 1.9 Nm (for CRB 15000-10/1.52 and CRB 15000-12/1.27)
9	Remove the lifting aid by removing the screws.	 <p>xx2000002090</p>
10	Clean pushed-out flange sealant, if any.	

Connecting the axis-4 joint unit cabling

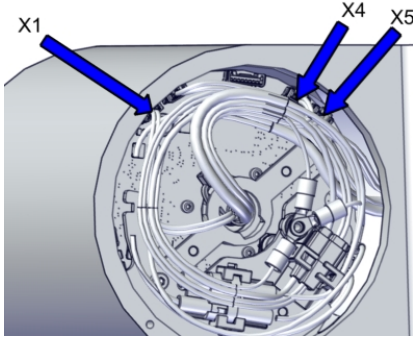
	Action	Note
1	Reconnect the connectors to the drive board. <ul style="list-style-type: none"> • D4/5.X1 to X1 • D4/5.X4 to X4 • D4/5.X5 to X5 	 <p>xx2000002088</p>

Continues on next page

5 Repair

5.6.6 Replacing the axis-4 joint unit

Continued

Connecting the tilt cabling

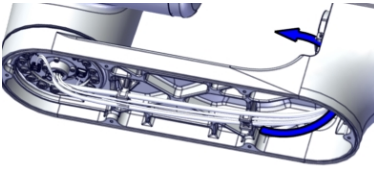
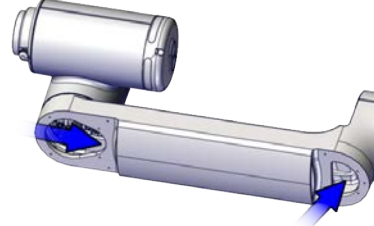
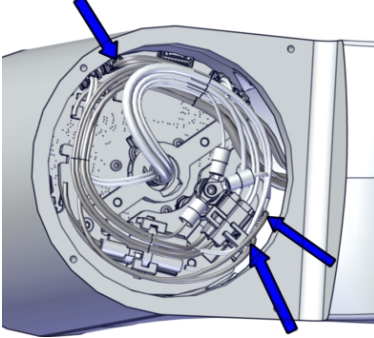
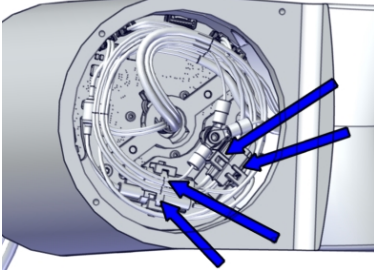
	Action	Note
1	Insert the cabling into the tubular.	<p>Valid for CRB 15000-5/0.95</p>  <p>xx2000002148</p> <p>Valid for CRB 15000-10/1.52 and CRB 15000-12/1.27</p>  <p>xx2300000845</p>
2	<p>Reconnect the connectors to the drive board.</p> <ul style="list-style-type: none"> • D3/4.X2 to X2 • D3/4.DC- to Ground • D3/4.DC+ to +DC 	 <p>xx2000002125</p>
3	<p>Connect the connectors to each other and snap them to the cable holders.</p> <ul style="list-style-type: none"> • J4/5.DC+ to J5/6.DC+ • J4/5.DC- to J5/6.DC- • J4/5.CS to J5/6.CS • J4/5.CP to J5/6.CP 	 <p>xx2000002089</p>

Continues on next page

5.6.6 Replacing the axis-4 joint unit

Continued

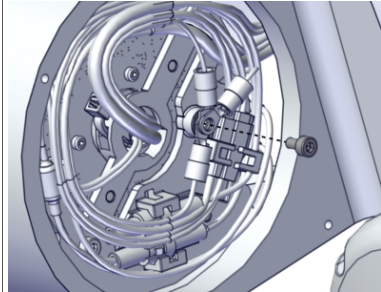
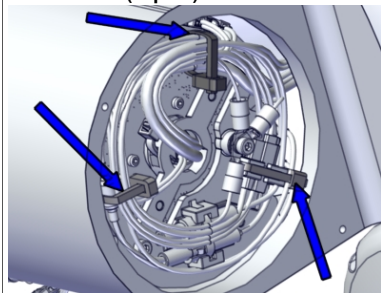
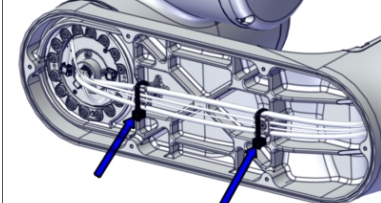
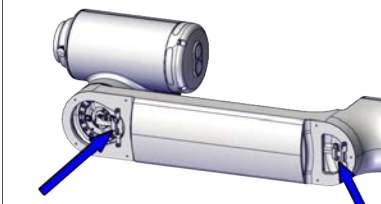
	Action	Note
4	Secure the cables for functional earth and protective earth with a screw.	<p>Hex socket head cap screw: M3x6 (1 pcs). Tightening torque: 0.8 Nm.</p>  <p>xx2000002087</p>
5	Secure the cabling to joint unit with cable ties.	<p>Cable ties (3 pcs)</p>  <p>xx2000002086</p>
6	Secure the cabling to tubular with cable ties.	<p>Cable ties (2 pcs) Valid for CRB 15000-5/0.95</p>  <p>xx2000002124</p> <p>Valid for CRB 15000-10/1.52 and CRB 15000-12/1.27</p>  <p>xx2300000842</p>

Continues on next page

5 Repair

5.6.6 Replacing the axis-4 joint unit

Continued

Refitting the tubular cover (-5/0.95)

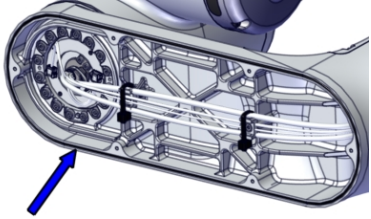
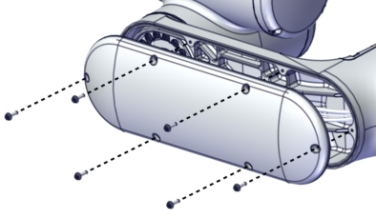
	Action	Note
1	Wipe, lubricate and fit the o-ring to its groove. Replace if damaged.	<p>O-ring: 3HAC061327-043 Grease: 3HAC042536-001 (Shell Gadus S2)</p>  <p>xx2000002149</p>
2	Refit the cover with new attachment screws.	<p>Flange socket head screw with glue: 3HAB3413-312 M3x12 12.9 Lafre 2C2B/FC6.9+PrO-COat111, with NYPLAS glue For tubular cover of CRB 15000-5/0.95. Always use new screws. If ordering a new axis-4 or axis-5 joint unit spare part, new screws for the tubular cover are included. Tightening torque: 1.6 Nm.</p>  <p>xx2000002123</p>

Continues on next page

Refitting the tubular cover (-10/1.52 and -12/1.27)

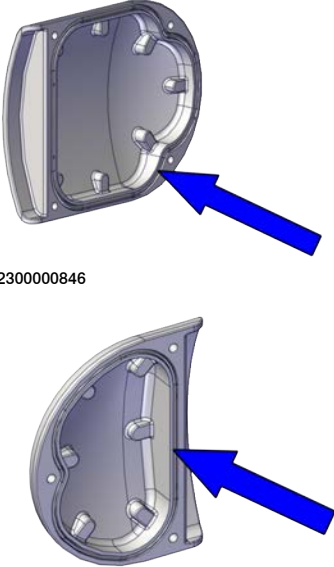
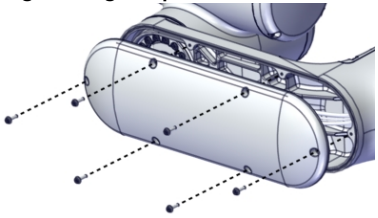
	Action	Note
1	Wipe, lubricate and fit the o-ring to its groove. Replace if damaged.	<p>O-ring: 3HAC061327-076 O-ring: 3HAB3772-166 Grease: 3HAC042536-001 (Shell Gadus S2)</p>  <p>xx2300000846</p> <p>xx2300000847</p>
2	Refit the covers with new attachment screws.	<p>Hex socket head cap screw: 3HAB3409-224 M3x12 12.9 Lafre 2C2B/FC6.9 (3 pcs) Tightening torque: 1.4 Nm.</p>  <p>xx2000002123</p>

Continues on next page

5 Repair

5.6.6 Replacing the axis-4 joint unit

Continued

Refitting the axis-4 cover

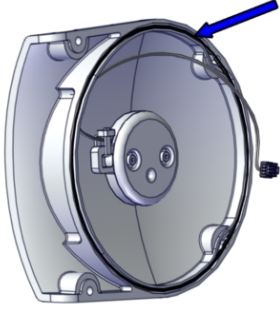
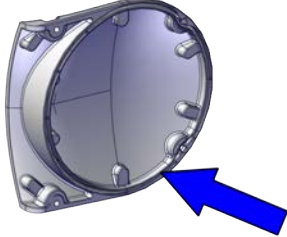
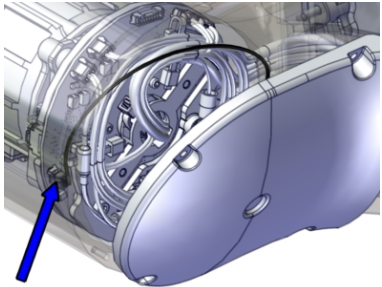
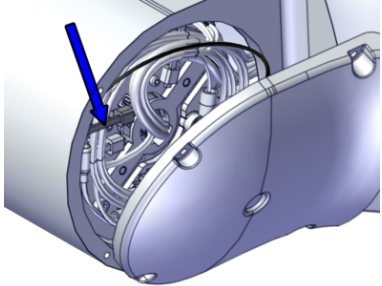
	Action	Note
1	Fit the o-ring to its groove. Replace if damaged.	<p>Valid for CRB 15000-5/0.95 O-ring: 3HAC061327-051</p>  <p>xx200002092</p> <p>Valid for CRB 15000-10/1.52 and CRB 15000-12/1.27 O-ring: 3HAC061327-051</p>  <p>xx2300000848</p>
2	For robots with RobotWare earlier than 7.10 Place the cover at mounting position and reconnect the brake release connector DR.X8 to the drive board.	<p>Tweezers</p>  <p>xx200002085</p>
3	For robots with RobotWare earlier than 7.10 Secure the brake release cable with a cable tie.	<p>Cable ties</p>  <p>xx200002084</p>

Continues on next page

5.6.6 Replacing the axis-4 joint unit

Continued

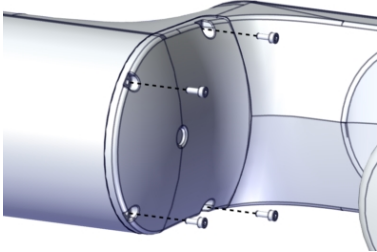
	Action	Note
4	Refit the cover with the four screws.	<p>Hex socket head cap screw: M3x8 12.9 Lafre 2C2B/FC6.9 (4 pcs) Tightening torque: 0.2 Nm (for CRB 15000-5/0.95) / 0.9 Nm (for CRB 15000-10/1.52 and CRB 15000-12/1.27) Tightening torque: 0.9 Nm</p>  <p>xx2000002083</p>

Refitting the tubular

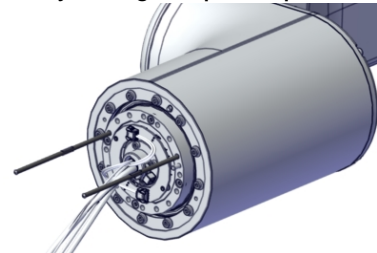
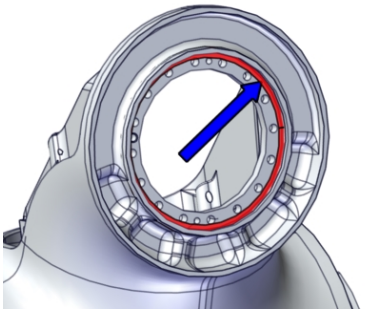
	Action	Note
1	Fit two guide pins to the axis-4 joint.	<p>Guide pin, M3x110: 3HAC077787-001 Always use guide pins in pairs.</p>  <p>xx2000002093</p>
2	<p>Clean the mounting surface with isopropanol. Apply flange sealant to the corner of the housing mounting surface, as pointed out in the figure.</p>	<p>Cleaning agent: Isopropanol Flange sealant: Loctite 574</p>  <p>xx2000002094</p>

Continues on next page

5 Repair

5.6.6 Replacing the axis-4 joint unit

Continued

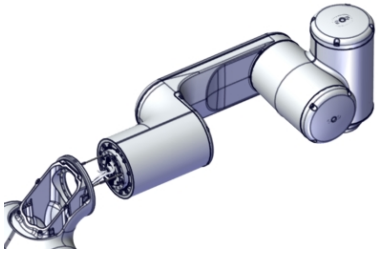
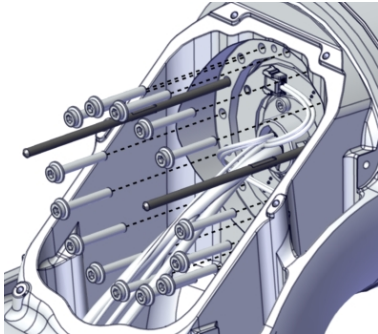
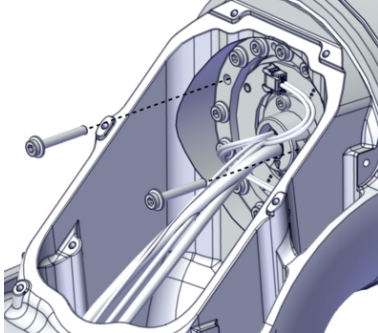
	Action	Note
3	Lift the tubular into mounting position while inserting the cabling into the housing.	 xx2000002082
4	Slide the tubular into place on the guide pins.	
5	Secure the tubular to the housing with all attachment screws but two. Pre-tighten the screws crosswise firstly.	Flange socket head screw: M3x20 12.9 Lafre 2C2B/FC6.9+PrO- COat111  xx2000002081
6	Remove the guide pins and fasten the remaining two screws.	Flange socket head screw: M3x20 12.9 Lafre 2C2B/FC6.9+PrO- COat111  xx2000002079
7	Torque tighten all screws crosswise.	Tightening torque: 1.8 Nm.

Continues on next page

5.6.6 Replacing the axis-4 joint unit

Continued

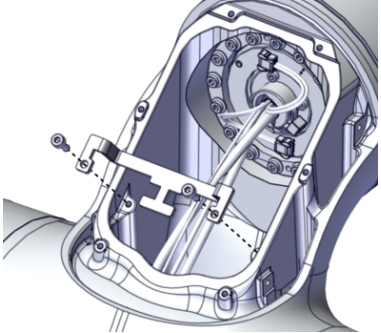
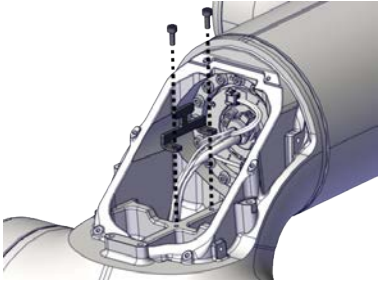
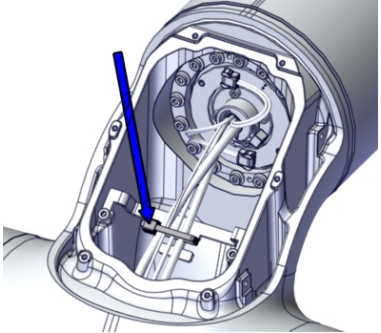
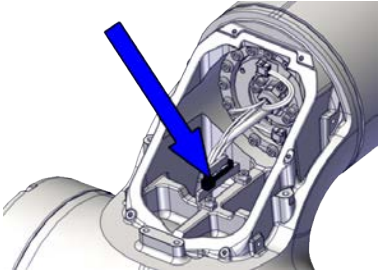
	Action	Note
8	Refit the cable bracket with the two screws.	<p>Hex socket head cap screw: M3x8 12.9 Lafre 2C2B/FC6.9 (4 pcs). Tightening torque: 0.8 Nm Valid for CRB 15000-5/0.95</p>  <p>xx2000002078</p> <p>Valid for CRB 15000-10/1.52 and CRB 15000-12/1.27</p>  <p>xx2300000840</p>
9	Secure the cabling with a cable tie.	<p>Cable ties (1 pcs) Valid for CRB 15000-5/0.95</p>  <p>xx2000002077</p> <p>Valid for CRB 15000-10/1.52 and CRB 15000-12/1.27</p>  <p>xx2300000839</p>

Continues on next page

5 Repair

5.6.6 Replacing the axis-4 joint unit

Continued

Closing the housing top cover

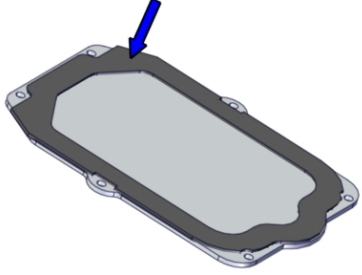
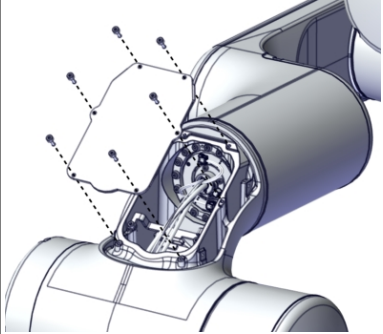
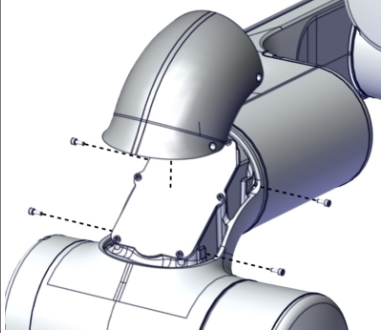
	Action	Note
1	Check the inner plate gasket. Replace if damaged.	Gasket: 3HAC075056-001  xx2000002095
2	Refit the inner plate with the screws.	Hex socket head cap screw: M3x8 12.9 Lafre 2C2B/FC6.9 (4 pcs). Tightening torque: 1.4 Nm  xx2000002076
3	Refit the cover with the four screws.	Hex socket head cap screw: M3x8 12.9 Lafre 2C2B/FC6.9 (4 pcs). Tightening torque: 0.45 Nm  xx2000002075

Continues on next page

Connecting the tubular cabling

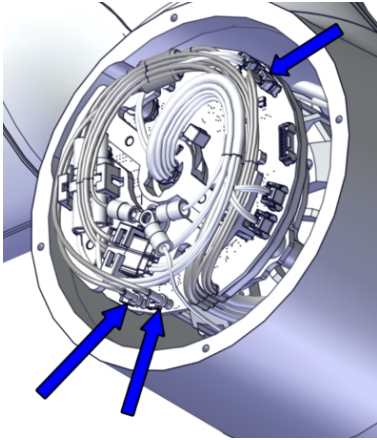
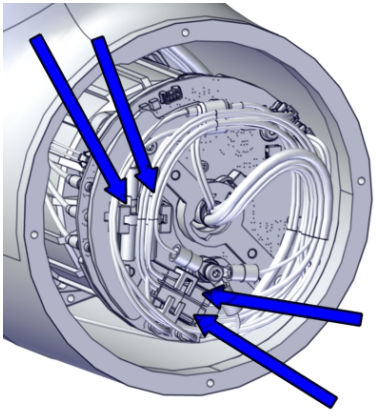
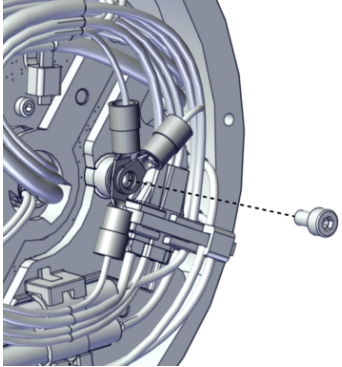
	Action	Note
1	Reconnect the connectors to the drive board. <ul style="list-style-type: none"> • D3/4.DC+ to DC+ • D3/4.DC- to Ground • D3/4.X2 to X2 	 <p>xx2000002120</p>
2	Connect the connectors to each other and snap them to the cable holders. <ul style="list-style-type: none"> • J3.DC+ to J3.DC+ • J3.DC- to J3.DC- • J3.CS to J3.CS • J3.CP to J3.CP 	 <p>xx2000002067</p>
3	Secure the cables for functional earth and protective earth with a screw.	Hex socket head cap screw: M3x6 (1 pcs). Tightening torque: 0.8 Nm.  <p>xx2000001945</p>

Continues on next page

5 Repair

5.6.6 Replacing the axis-4 joint unit

Continued

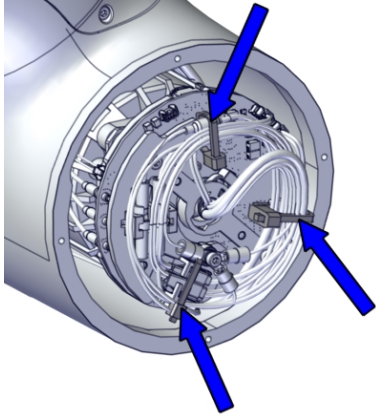
	Action	Note
4	Secure the cabling with cable ties.	Cable ties (3 pcs)  xx2000002066

Refitting the housing cover (-5/0.95)

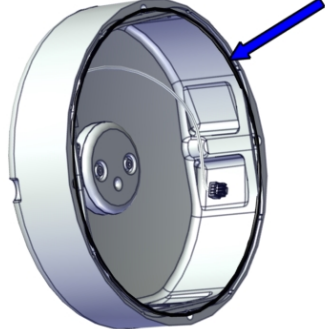
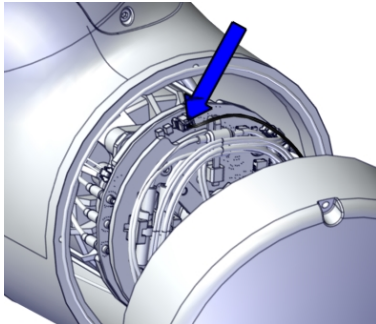
	Action	Note
1	Fit the o-ring to its groove. Replace if damaged.	O-ring: 3HAC061327-047  xx2000001962
2	For robots with RobotWare earlier than 7.10 Place the cover at mounting position and reconnect the brake release connector DR.X8 to the drive board. Orient the cover for proper arrangement of the brake release cable.	 xx2000002023

Continues on next page

5.6.6 Replacing the axis-4 joint unit

Continued

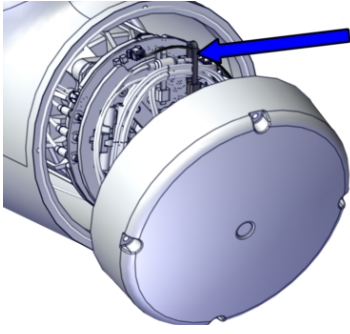
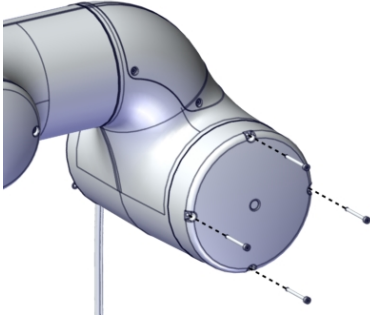
	Action	Note
3	<p>For robots with RobotWare earlier than 7.10 Secure the brake release cable with a cable tie.</p>	<p>Cable ties</p>  <p>xx2000002022</p>
4	<p>Refit the cover with the four screws.</p>	<p>Hex socket head cap screw: M3x30 12.9 Lafre 2C2B/FC6.9 (4 pcs) Tightening torque: 0.45 Nm</p>  <p>xx2000002021</p>

Refitting the housing cover and insert (-10/1.52 and -12/1.27)

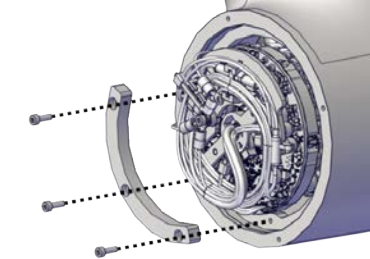
	Action	Note
1	<p>Refit the insert.</p>	<p>Insert: 3HAC084002-001 Hex socket head cap screw: M3x10 12.9 Lafre 2C2B/FC6.9 (3 pcs) Tightening torque: 1.4 Nm</p>  <p>xx2300000834</p>

Continues on next page

5 Repair

5.6.6 Replacing the axis-4 joint unit

Continued

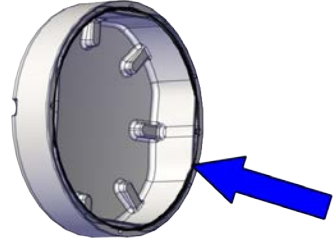
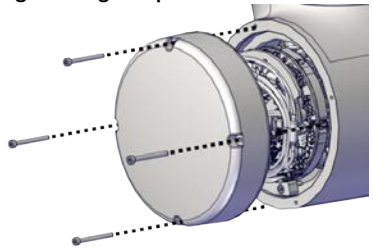
	Action	Note
2	Fit the o-ring to its groove. Replace if damaged.	O-ring: 3HAC061327-047  xx2300000835
3	Refit the cover with the four screws.	Hex socket head cap screw: M3x30 12.9 Lafre 2C2B/FC6.9 (4 pcs) Tightening torque: 1.4 Nm  xx2300000833

Concluding procedure

	Action	Note
1	<p>Calibrate the joint unit torque sensor.</p> <ol style="list-style-type: none"> 1 On the FlexPendant, go to the Code app and call the calibration procedure using PP to Routine, not by using Call Routine. 2 Select the Joint Unit Replacement feature and then select the axis to calibrate. 3 The controller is now restarted. Once the home screen of the FlexPendant is shown, press the Play button to continue the calibration routine. 4 The robot moves to a position or positions where measurements are performed. 5 The results of the measurements are presented together with the current values in the controller. Choose whether to save the calibration data or not. 6 If new calibration data is saved you will be asked to do a test with the lead-through functionality active to verify that the sensors work correctly. 7 Finally the robot is moved back to the original position. 8 Test the brake release (movement without drive power) functionality, see Testing the brake release functionality on page 196. 	See Calibration on page 1063

Continues on next page

	Action	Note
2	 DANGER Make sure all safety requirements are met when performing the first test run. See Test run after installation, maintenance, or repair on page 90 .	

5 Repair

5.6.7 Replacing the axis-5 joint unit and the axis-5 to axis-6 transition cabling

5.6.7 Replacing the axis-5 joint unit and the axis-5 to axis-6 transition cabling

Location of the axis-5 joint unit

The joint unit is located as shown in the figure.

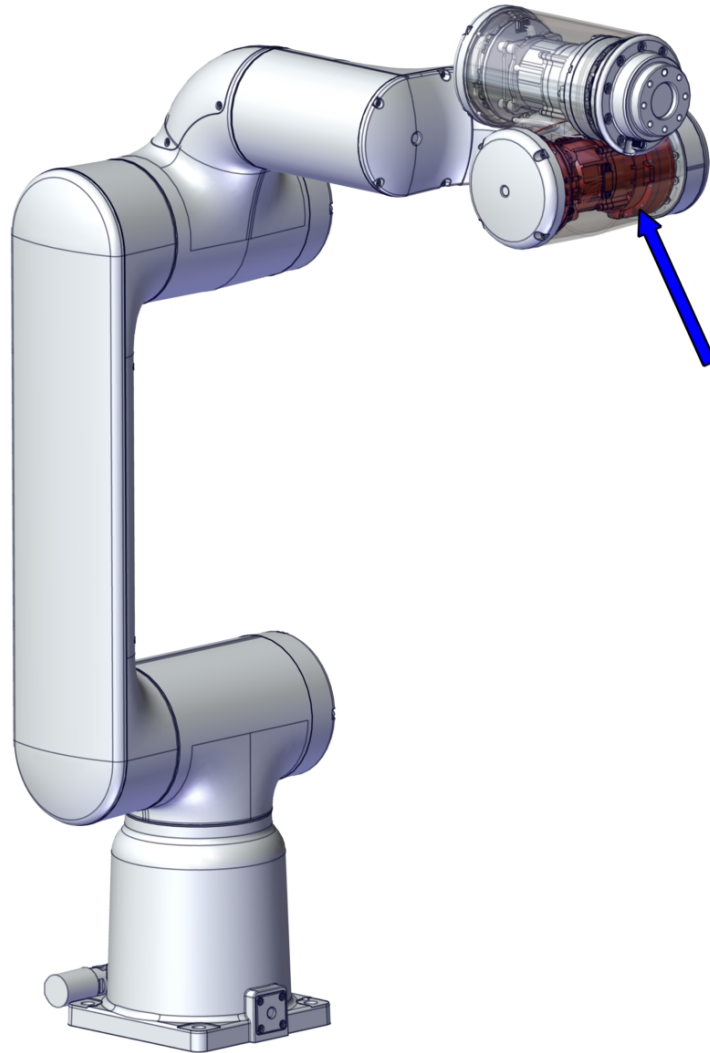

xx2000002121

Continues on next page

5.6.7 Replacing the axis-5 joint unit and the axis-5 to axis-6 transition cabling

Continued

Location of the axis-5 to axis-6 transition cabling

The cable harness is located as shown in the figure.

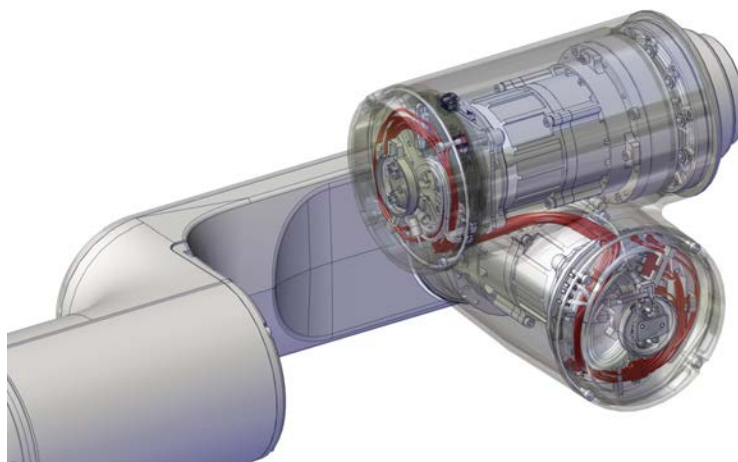

xx210000091

Summary of the replacement procedure

This is a brief summary of the replacement procedure, containing the major actions to be performed.

- 1 Remove the tubular cover.
- 2 Separate the cabling between the tubular and the tilt (at the axis-4 joint unit).
- 3 Remove the tilt and place on a workbench.
- 4 Remove the axis-6 joint unit.
- 5 Remove the axis-5 cover.
- 6 Replace the joint unit. Move the cabling from old to new joint unit.
- 7 Replace the axis-5 to axis-6 transition cabling.

Required spare parts



Note

The spare part numbers that are listed in the table can be out of date. See the latest spare parts of the CRB 15000 via myABB Business Portal, www.abb.com/myABB.

Spare part	Article number	Note
Joint unit	3HAC079143-001	Used for CRB 15000-5/0.95. New attachment screws and cable tie 3HAC075545-001 are included in the delivery.
Joint unit	3HAC087546-001	New attachment screws and cable tie 3HAC075545-001 are included in the delivery.
Cable harness, transition joint-5 and joint-6	3HAC083726-001	

Continues on next page

5 Repair

5.6.7 Replacing the axis-5 joint unit and the axis-5 to axis-6 transition cabling

Continued

Required tools and equipment

Equipment	Article number	Note
Lifting aid	3HAC077789-001	For joint units on axes 4, 5 and 6. Attachment screws M3x12 (4 pcs) are enclosed.
Guide pin, M3x110	3HAC077787-001	Always use guide pins in pairs. For joint units on axes 4, 5 and 6.
Protection plate	3HAC077790-001	For protection of drive board during cabling installation on joint units of CRB 15000-5/0.95.
Protection plate	3HAC087789-001	For protection of drive board during cabling installation on joint units of CRB 15000-10/1.52 and CRB 15000-12/1.27.
Cable tie gun EVO 7i	-	HellermannTyton 110-77001 or similar
Tweezers	-	Used to handle drive board connectors.
Standard toolkit	-	Content is defined in section Standard toolkit on page 1099 .

Required consumables

Consumable	Article number	Note
Cleaning agent	-	Isopropanol
Flange sealant	-	Loctite 574
Grease	3HAC042536-001	Shell Gadus S2
Cable ties	-	
O-ring	3HAC061327-051	Axis-5 cover, used for CRB 15000-5/0.95. Replace if damaged.
O-ring	3HAC061327-051	Axis-5 cover, used for CRB 15000-10/1.52 and CRB 15000-12/1.27. Replace if damaged.
O-ring	3HAC061327-051	Arm-side interface Replace if damaged.
O-ring	3HAC061327-043	Tubular cover, used for CRB 15000-5/0.95. Replace if damaged.
Flange socket head screw with glue	3HAB3413-312	M3x12 12.9 Lafre 2C2B/FC6.9+PrO-COat111, with NYPLAS glue For tubular cover of CRB 15000-5/0.95. Always use new screws. If ordering a new axis-4 or axis-5 joint unit spare part, new screws for the tubular cover are included.

Continues on next page

5.6.7 Replacing the axis-5 joint unit and the axis-5 to axis-6 transition cabling



Continued

Consumable	Article number	Note
O-ring	3HAC061327-076	Tubular cover, lower, used for CRB 15000-10/1.52 and CRB 15000-12/1.27. Replace if damaged.
O-ring	3HAB3772-166	Tubular cover, upper, used for CRB 15000-10/1.52 and CRB 15000-12/1.27. Replace if damaged.
O-ring	3HAC061327-051	Axis-4 cover, used for CRB 15000-5/0.95. Replace if damaged.
O-ring	3HAC061327-051	Axis-4 cover, used for CRB 15000-10/1.52 and CRB 15000-12/1.27. Replace if damaged.

Removing the joint unit and transition cabling

Use these procedures to remove the joint unit and transition cabling.

Preparations before removing the joint unit and transition cabling

	Action	Note
1	<p>Jog the robot to the specified position:</p> <ul style="list-style-type: none"> • Axis 1: No significance. • Axis 2: No significance. • Axis 3: No significance. • Axis 4: No significance. • Axis 5: 0° (home position) • Axis 6: No significance. <p> CAUTION</p> <p>Jog the axis on which the joint unit is to be replaced to home position, to achieve correct cable routing during replacement of the joint unit.</p>	
2	<p> CAUTION</p> <p>Turn off all supplies for electrical power to the robot, before starting the repair work.</p>	

Removing the tubular cover

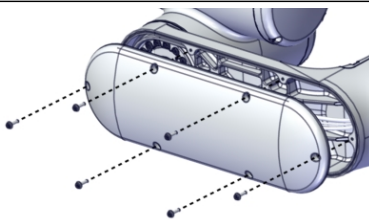
	Action	Note
1	<p>Valid for CRB 15000-5/0.95</p> <p>Remove the cover by removing the six screws. Dispose the screws. New screws must be used when refitting the cover.</p> <p>New screws are included in the spare part delivery of the joint unit.</p>	 <p>xx2000002123</p>

Continues on next page



5 Repair

5.6.7 Replacing the axis-5 joint unit and the axis-5 to axis-6 transition cabling

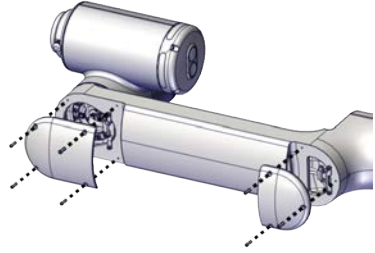
Continued

	Action	Note
2	<p>Valid for CRB 15000-10/1.52 and CRB 15000-12/1.27</p> <p>Remove the covers by removing the screws.</p>	 <p>xx2300000841</p>

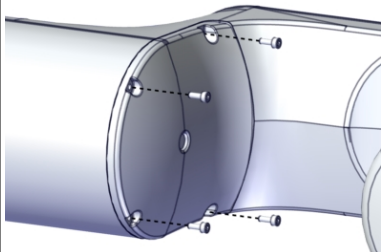
Removing the axis-4 cover

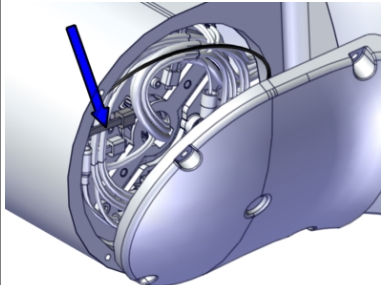
	Action	Note
1	Remove the cover screws.	 <p>xx2000002083</p>
2	<p> CAUTION</p> <p>Valid for CRB 15000-5/0.95</p> <p>There is cabling connected between the cover and the joint unit drive board.</p> <p>Open the cover with care to avoid damage to the cabling or the connector(s).</p> <p>Do not leave the cover in location without being secured with the attachment screws.</p>	
3	<p>For robots with RobotWare earlier than 7.10</p> <p>Open the cover and cut the cable tie that holds the brake release cable.</p>	 <p>xx2000002084</p>

Continues on next page

5.6.7 Replacing the axis-5 joint unit and the axis-5 to axis-6 transition cabling
Continued

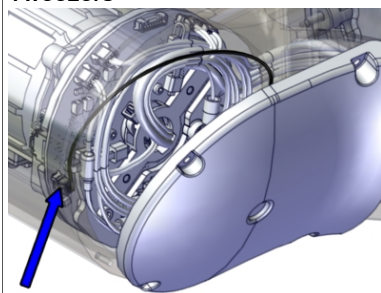
	Action	Note
4	<p>For robots with RobotWare earlier than 7.10 Disconnect the brake release connector DR.X8 from the drive board. Remove the cover.</p>	<p>Tweezers</p>  <p>xx2000002085</p>

Separating the cabling between the tubular and the tilt

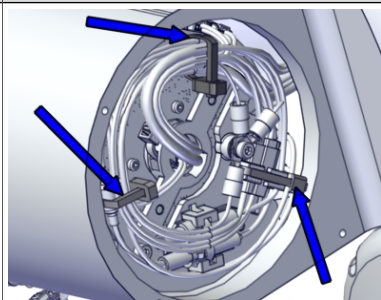
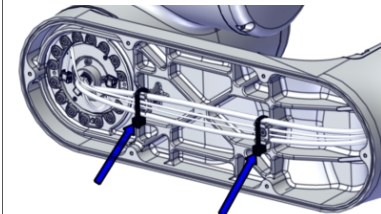
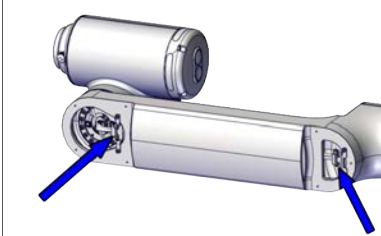
	Action	Note
1	<p>Cut the cable ties on joint unit.</p>	 <p>xx2000002086</p>
2	<p>Cut the cable ties on tubular, if needed.</p>	<p>Valid for CRB 15000-5/0.95</p>  <p>xx2000002124</p> <p>Valid for CRB 15000-10/1.52 and CRB 15000-12/1.27</p>  <p>xx2300000842</p>

Continues on next page

5 Repair

5.6.7 Replacing the axis-5 joint unit and the axis-5 to axis-6 transition cabling

Continued

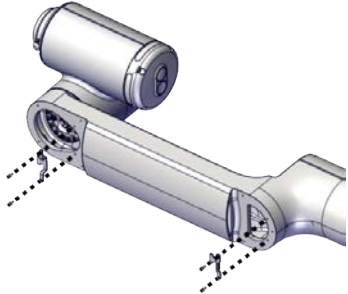
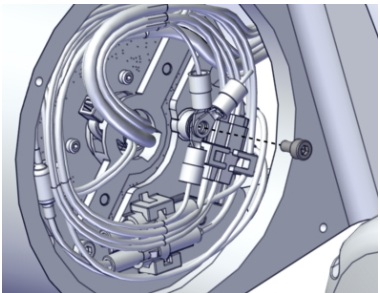
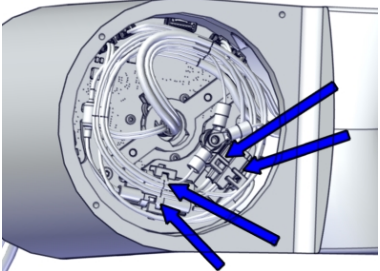
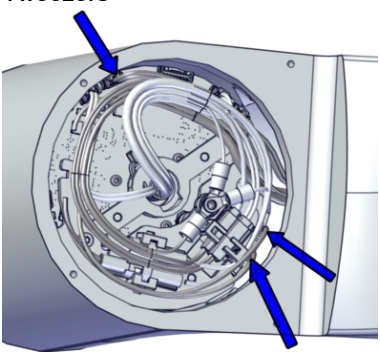
	Action	Note
3	<p>Valid for CRB 15000-10/1.52 and CRB 15000-12/1.27</p> <p>Remove the cable brackets.</p>	 <p>xx2300000843</p>
4	<p>Remove the functional and protective earth cables by removing the screw.</p>	 <p>xx2000002087</p>
5	<p>Snap loose and disconnect the connectors:</p> <ul style="list-style-type: none"> • J4/5.DC+ • J4/5.DC- • J4/5.CS • J4/5.CP 	 <p>xx2000002089</p>
6	<p>Disconnect the connectors that belongs to the axis-5 cabling, from the axis-4 drive board:</p> <ul style="list-style-type: none"> • D3/4.X2 • D3/4.DC- • D3/4.DC+ <p>Use tweezers, if needed.</p>	<p>Tweezers</p>  <p>xx2000002125</p>

Continues on next page

5.6.7 Replacing the axis-5 joint unit and the axis-5 to axis-6 transition cabling
Continued

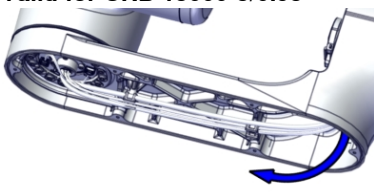
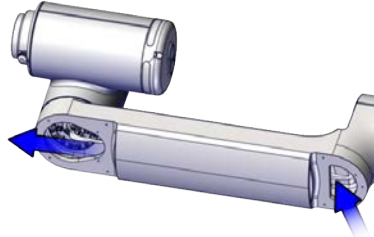
	Action	Note
7	Pull out the cabling carefully from the tubular.	<p>Valid for CRB 15000-5/0.95</p>  <p>xx2000002126</p> <p>Valid for CRB 15000-10/1.52 and CRB 15000-12/1.27</p>  <p>xx2300000844</p>

Removing the tilt

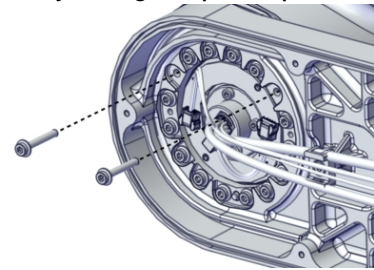
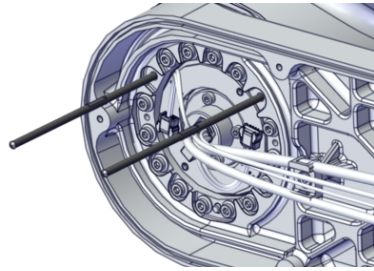
	Action	Note
1	Remove two attachment screws and fit two guide pins to the axis-5 joint unit.	<p>Guide pin, M3x110: 3HAC077787-001 Always use guide pins in pairs.</p>  <p>xx2000002128</p>  <p>xx2000002129</p>

Continues on next page



5 Repair

5.6.7 Replacing the axis-5 joint unit and the axis-5 to axis-6 transition cabling

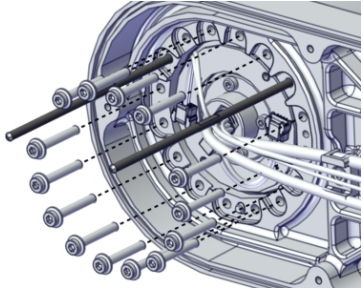
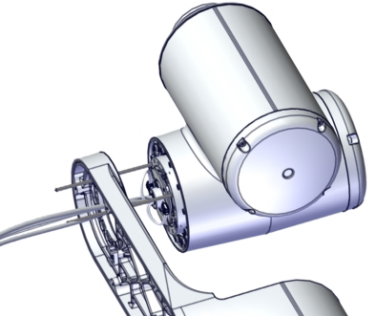
Continued

	Action	Note
2	Remove the remaining attachment screws.	 <p>xx2000002130</p>
3	Press the tilt out of position using two of the previous attachment screws as removal tools.	
4	Remove the tilt from the tubular. Assist the cabling to be removed while lifting away the complete tilt. Place the tilt on a workbench.	 <p>xx2000002131</p>

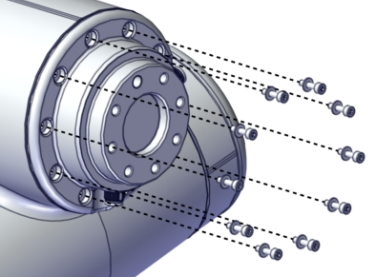
Removing the tool flange

	Action	Note
1	Remove the tool flange screws and washers.	 <p>xx2000002155</p>
2	 CAUTION Valid for CRB 15000-5/0.95 There is cabling connected between the cover and the joint unit drive board. Open the cover with care to avoid damage to the cabling or the connector(s). Do not leave the cover in location without being secured with the attachment screws.	

Continues on next page

5.6.7 Replacing the axis-5 joint unit and the axis-5 to axis-6 transition cabling
Continued

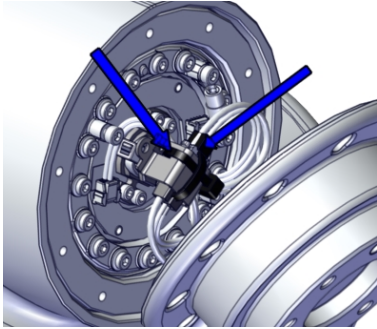
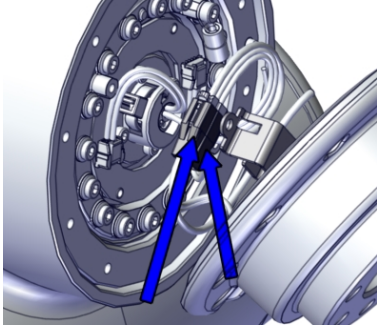
	Action	Note
3	Cut the cable ties.	 <p>xx2000002157</p>
4	Disconnect the CP/CS connectors from the drive board and remove the tool flange.	 <p>xx2000002158</p>

Disconnecting the tool flange functional earth cable

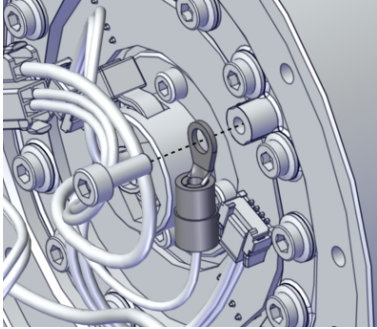
	Action	Note
1	Remove the functional earth cable by removing the screw.	 <p>xx2000002159</p>

Removing the tool flange adapter

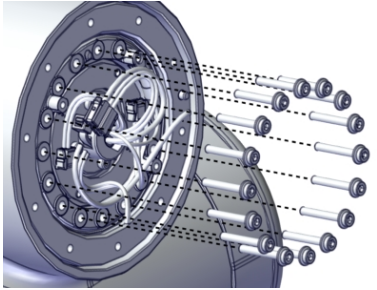
	Action	Note
1	Remove the tool flange adapter screws.	 <p>xx2000002165</p>

Continues on next page



5 Repair

5.6.7 Replacing the axis-5 joint unit and the axis-5 to axis-6 transition cabling

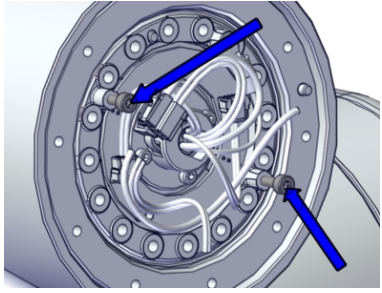
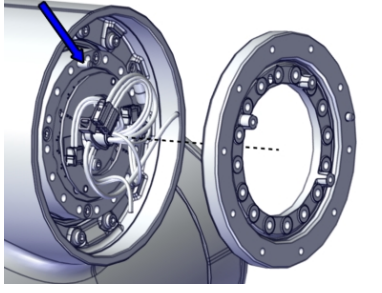
Continued

	Action	Note
2	Press the adapter out of position by using two of the attachment screws as removal tools.	 <p>xx2000002166</p>
3	Remove the tool flange adapter.	 <p>xx2000002167</p>

Removing the arm-side interface

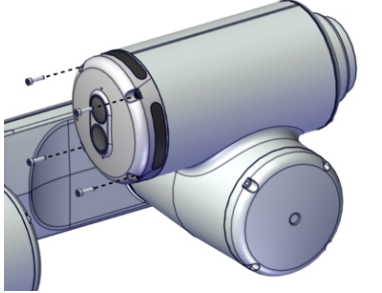
	Action	Note
1	 CAUTION Make sure that all supplies for electrical power are turned off.	
2	 CAUTION There is cabling connected between the arm-side interface and the joint unit drive board. Open the arm-side interface with care to avoid damage to the cabling or the connector(s). Do not leave the arm-side interface in location without being secured with the attachment screws.	
3	Remove the attachment screws.	 <p>xx2000002550</p>

Continues on next page

5.6.7 Replacing the axis-5 joint unit and the axis-5 to axis-6 transition cabling
Continued

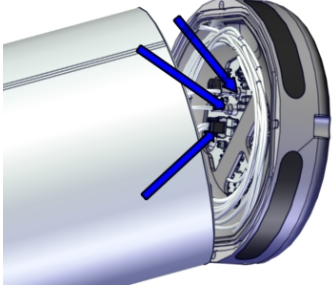
	Action	Note
4	Loosen the arm-side interface carefully and disconnect the connectors from it. <ul style="list-style-type: none"> • ASI.DC+ • ASI.DC- • ASI.X1 	 <p>xx2100000335</p>

Disconnecting the axis-6 joint unit cabling

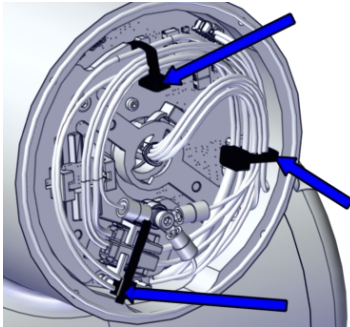
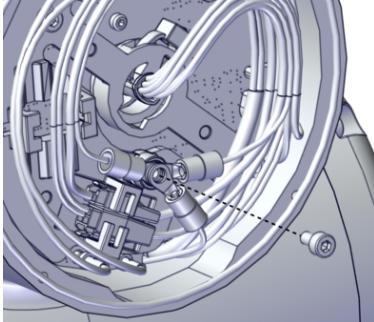
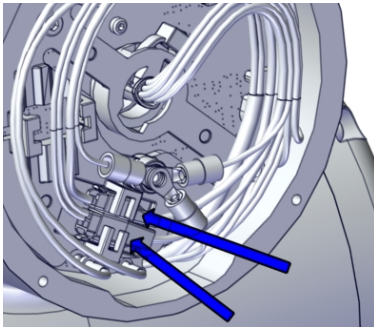
	Action	Note
1	Cut the cable ties.	 <p>xx2000002161</p>
2	Remove the functional and protective earth cables by removing the screw.	 <p>xx2000002162</p>
3	Snap loose and disconnect the connectors: <ul style="list-style-type: none"> • J7.CS • J7.CP 	 <p>xx2000002163</p>

Continues on next page

5 Repair

5.6.7 Replacing the axis-5 joint unit and the axis-5 to axis-6 transition cabling

Continued

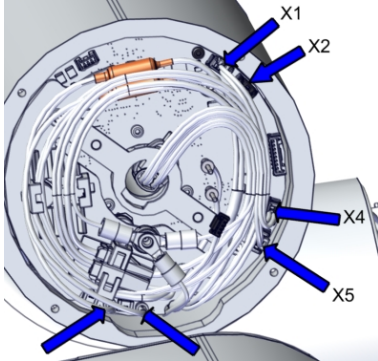
	Action	Note
4	<p>Disconnect the connectors from the drive board.</p> <ul style="list-style-type: none"> • D6.X1 • D6.DC+ • D6.DC- • D6.X4 • D6.X2 • D6.X5 <p> CAUTION</p> <p>Use tweezers to unlock connectors and pull them off.</p>	<p>Tweezers</p>  <p>xx2000002164</p>

Removing the axis-6 joint unit

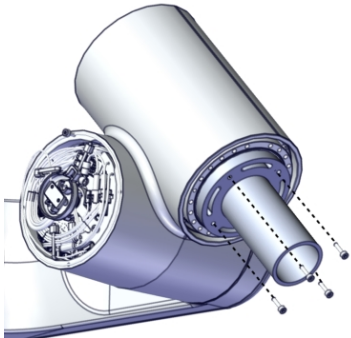
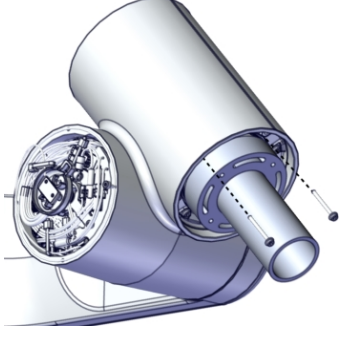
	Action	Note
1	<p>Fit the lifting aid to the joint unit, on the torque sensor side.</p> <p> CAUTION</p> <p>The connectors and the joint unit cables are sensitive to mechanical damage. Handle the assembly with care.</p>	<p>Lifting aid: 3HAC077789-001 Screws: M3x12 (4 pcs)</p>  <p>xx2000002168</p> <p>Position shown in the figure shows axis 5 jogged to +20°, which is a more convenient position when replacing only the axis-6 joint unit.</p>
2	<p>Remove two attachment screws. Dispose the screws. New screws are included in the spare part delivery of the joint unit.</p>	 <p>xx2000002170</p> <p>Position shown in the figure shows axis 5 jogged to +20°, which is a more convenient position when replacing only the axis-6 joint unit.</p>

Continues on next page

5.6.7 Replacing the axis-5 joint unit and the axis-5 to axis-6 transition cabling
Continued

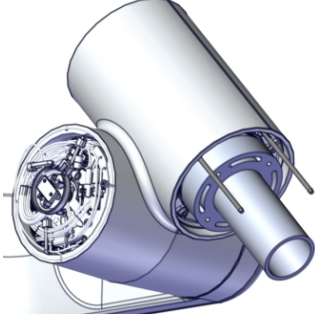
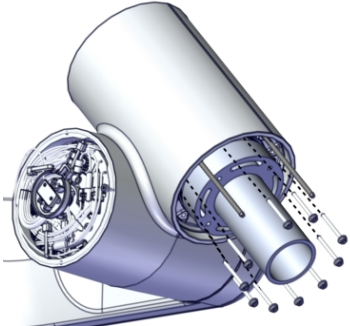
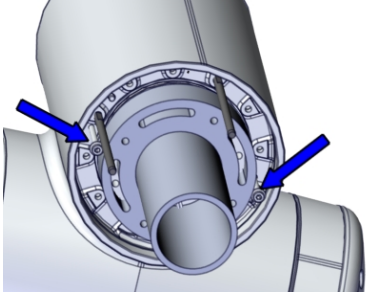
	Action	Note
3	Fit two guide pins to the axis-6 joint unit.	<p>Guide pin, M3x110: 3HAC077787-001</p> <p>Always use guide pins in pairs.</p> <p>For joint units on axes 4, 5 and 6.</p>  <p>xx2100000328</p>
4	<p>Remove the remaining attachment screws.</p> <p>Use two screws as press out screws in the upcoming step, then dispose all screws.</p> <p>New screws are included in the spare part delivery of the joint unit.</p>	 <p>xx2100000329</p>
5	Press the joint unit out of position using two of the previous attachment screws as removal tools.	 <p>xx2100000330</p>

Continues on next page



5 Repair

5.6.7 Replacing the axis-5 joint unit and the axis-5 to axis-6 transition cabling

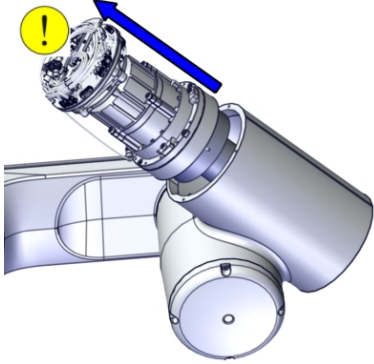
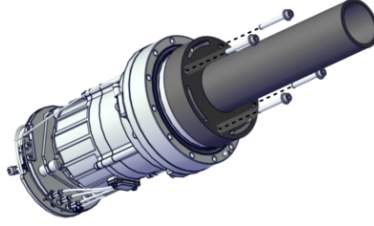
Continued

	Action	Note
6	<p>Remove the joint unit from the tubular.</p> <p> CAUTION</p> <p>The connectors and the joint unit cables are sensitive to mechanical damage. Handle the assembly with care.</p>	 <p>xx2000002169</p> <p>Position shown in the figure shows axis 5 jogged to +20°, which is a more convenient position when replacing only the axis-6 joint unit.</p>
7	<p>Remove the lifting aid and guide pins.</p>	 <p>xx2000001957</p>

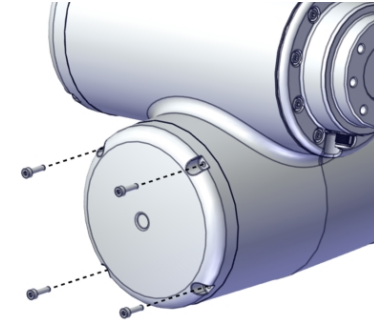
Removing the axis-5 cover

	Action	Note
1	<p>Remove the cover by removing the four screws.</p>	 <p>xx2000002132</p>
2	<p> CAUTION</p> <p>Valid for CRB 15000-5/0.95</p> <p>There is cabling connected between the cover and the joint unit drive board.</p> <p>Open the cover with care to avoid damage to the cabling or the connector(s).</p> <p>Do not leave the cover in location without being secured with the attachment screws.</p>	

Continues on next page

5.6.7 Replacing the axis-5 joint unit and the axis-5 to axis-6 transition cabling
Continued

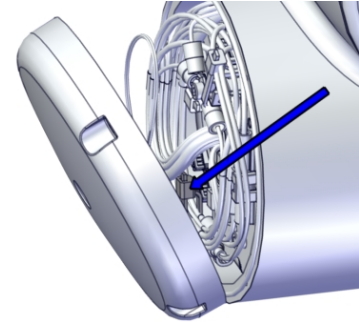
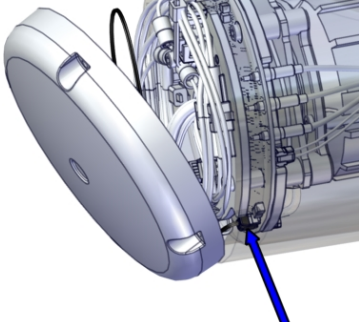
	Action	Note
3	<p>For robots with RobotWare earlier than 7.10 Open the cover and cut the cable tie that holds the brake release cable.</p>	 <p>xx2000002133</p>
4	<p>For robots with RobotWare earlier than 7.10 Disconnect the brake release connector DR.X8 from the drive board. Remove the cover.</p>	 <p>xx2000002134</p>

Disconnecting the axis-5 joint unit cabling

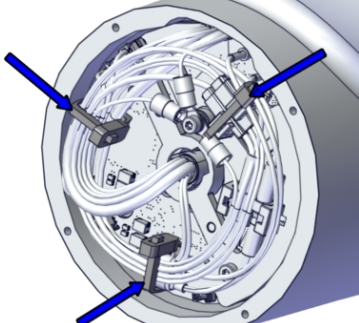
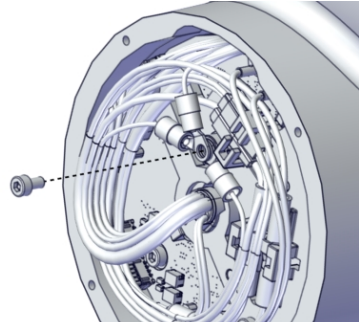

	Action	Note
1	<p>Cut the cable ties.</p>	 <p>xx2000002135</p>
2	<p>Remove the functional and protective earth cables by removing the screw.</p>	 <p>xx2000002136</p>

Continues on next page

5 Repair

5.6.7 Replacing the axis-5 joint unit and the axis-5 to axis-6 transition cabling

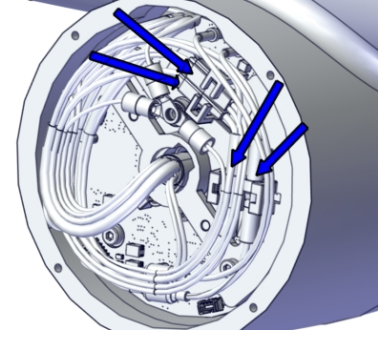
Continued

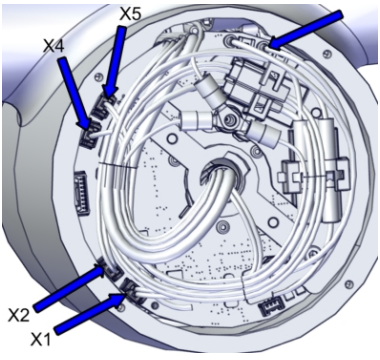

	Action	Note
3	Snap loose and disconnect the connectors: <ul style="list-style-type: none"> • J5/6.DC+ • J5/6.DC- • J5/6.CS • J5/6.CP 	 xx2000002137
4	Disconnect the connectors from the drive board. <ul style="list-style-type: none"> • D4/5.X1 • D5.DC+ • D5.DC- • D4/5.X4 • D5.X2 • D4/5.X5 <p> CAUTION</p> Use tweezers to unlock connectors and pull them off.	Tweezers  xx2000002138

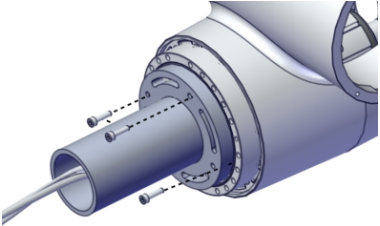
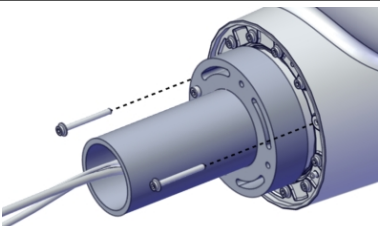
Removing the axis-5 joint unit

	Action	Note
1	Fit the lifting aid to the joint unit, on the torque sensor side. <p> CAUTION</p> The connectors and the joint unit cables are sensitive to mechanical damage. Handle the assembly with care.	Lifting aid: 3HAC077789-001 Screws: M3x12 (4 pcs)  xx2000002139
2	Remove two attachment screws. Dispose the screws. New screws are included in the spare part delivery of the joint unit.	 xx2000002140

Continues on next page

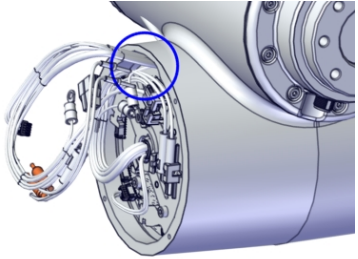
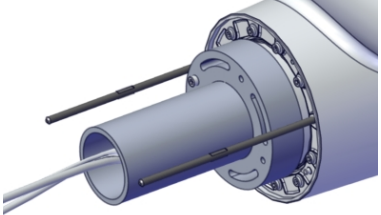
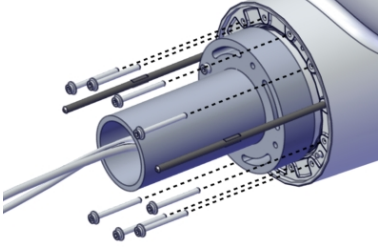
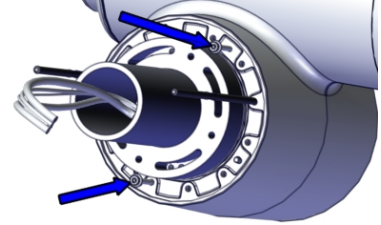
5.6.7 Replacing the axis-5 joint unit and the axis-5 to axis-6 transition cabling
Continued

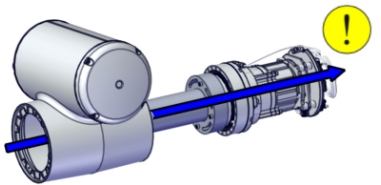
	Action	Note
3	Put the cabling at the slot in order not to squeeze it during removal of joint unit.	 <p>xx210000284</p>
4	Fit two guide pins to the axis-5 joint unit.	<p>Guide pin, M3x110: 3HAC077787-001 Always use guide pins in pairs. For joint units on axes 4, 5 and 6.</p>  <p>xx210000332</p>
5	Remove the remaining attachment screws. Use two screws as press out screws in the upcoming step, then dispose all screws. New screws are included in the spare part delivery of the joint unit.	 <p>xx210000333</p>
6	Press the joint unit out of position using two of the previous attachment screws as removal tools.	 <p>xx210000334</p>
7	<p>Remove the joint unit from the tubular.</p> <p> CAUTION</p> <p>The connectors and the joint unit cables are sensitive to mechanical damage. Handle the assembly with care.</p>	 <p>xx2000002141</p>

Continues on next page



5 Repair

5.6.7 Replacing the axis-5 joint unit and the axis-5 to axis-6 transition cabling

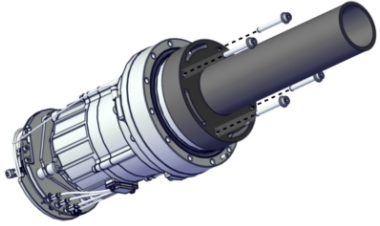
Continued

	Action	Note
8	Remove the lifting aid and guide pins.	 xx200001957

Removing the joint cable

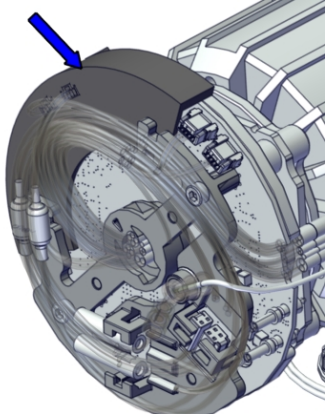
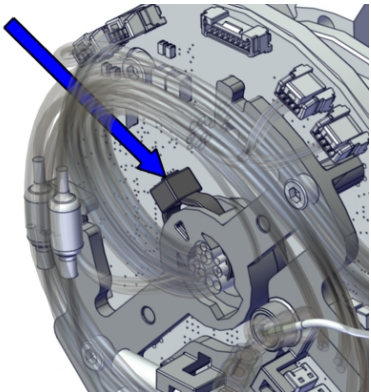
	Action	Note
1	 ELECTROSTATIC DISCHARGE (ESD) The unit is sensitive to ESD. Before handling the unit read the safety information in section The unit is sensitive to ESD on page 53 .	
2	Fit the protection plate to the drive board unit.  Tip Using the protection plate is important for protecting the drive board unit. If complete joint unit is to be replaced, the protection plate is not needed.	Protection plate: 3HAC077790-001 (for CRB 15000-5/0.95) / 3HAC087789-001 (for CRB 15000-10/1.52 and CRB 15000-12/1.27)  xx200002057
3	Cut the cable tie at the drive board.	 xx200002058

Continues on next page

5.6.7 Replacing the axis-5 joint unit and the axis-5 to axis-6 transition cabling
Continued

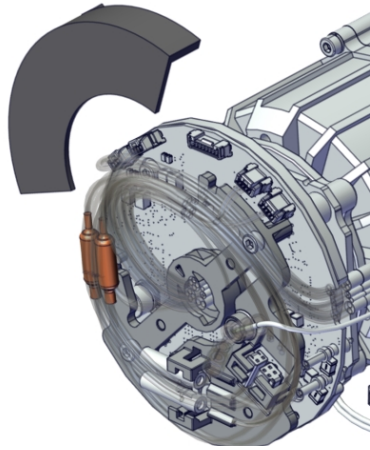
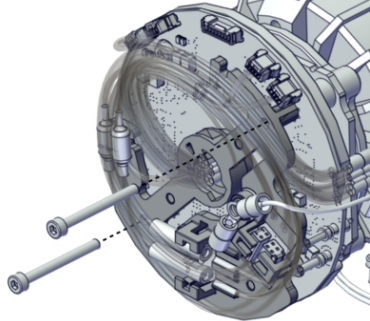
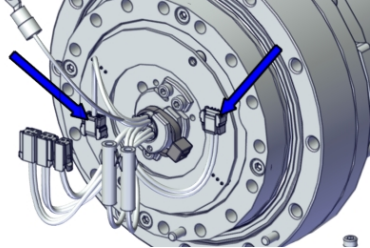
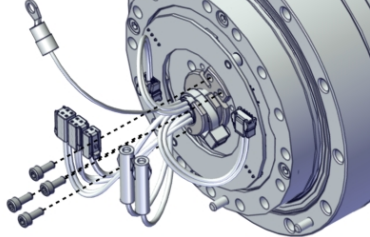
	Action	Note
4	Remove the protection plate.	 <p>xx2100000301</p>
5	Remove the cable support from the drive board by removing the attachment screws.	 <p>xx2000002055</p>
6	Disconnect the two connectors from the torque sensor board. <ul style="list-style-type: none"> • TQ.A • TQ.B 	 <p>xx2000002053</p>
7	Remove the cable plate by removing the attachment screws.	 <p>xx2000002049</p>

Continues on next page

5 Repair

5.6.7 Replacing the axis-5 joint unit and the axis-5 to axis-6 transition cabling

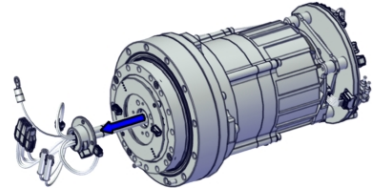

Continued

	Action	Note
8	<p>Remove the joint cable from the hollow shaft from the torque sensor side.</p> <p> CAUTION</p> <p>The connectors and the joint unit cables are sensitive to mechanical damage. Handle the assembly with care.</p>	 <p>xx2000002060</p>

Refitting the joint unit and transition cabling

Use these procedures to refit the joint unit and transition cabling.

Refitting the axis-5 joint unit cable

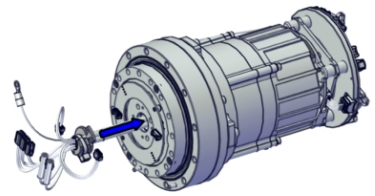
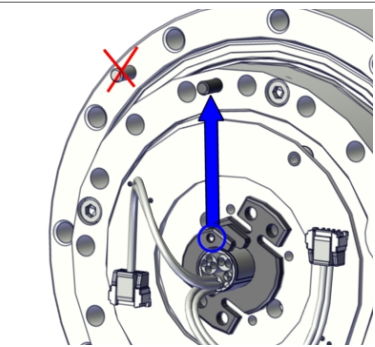
	Action	Note
1	<p> ELECTROSTATIC DISCHARGE (ESD)</p> <p>The unit is sensitive to ESD. Before handling the unit read the safety information in section The unit is sensitive to ESD on page 53.</p>	
2	<p>Place the joint cable through the hollow shaft from the torque sensor side.</p> <p> CAUTION</p> <p>The connectors and the joint unit cables are sensitive to mechanical damage. Handle the assembly with care.</p>	 <p>xx2000002048</p>
3	<p>Orient the cable plate according to the figure. The circle on the cable plate should point towards the guide pin on the torque sensor.</p>	 <p>xx2000002051</p>

Continues on next page

5.6.7 Replacing the axis-5 joint unit and the axis-5 to axis-6 transition cabling
Continued

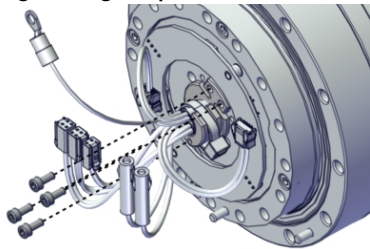
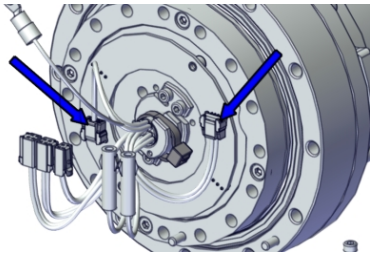
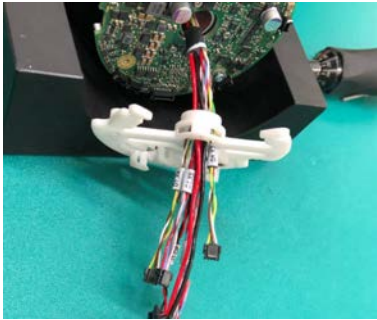
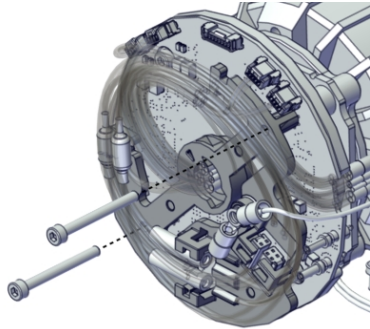
	Action	Note
4	Secure the cable plate to the joint unit with the attachment screws.	<p>Hex socket head cap screw: M2.5x6 12.9 Lafre 2C2B/FC6.9 (4 pcs) Tightening torque: 0.45 Nm.</p>  <p>xx2000002049</p>
5	<p>Connect the two connectors to the torque sensor board.</p> <ul style="list-style-type: none"> • TQ.A to CH1/A • TQ.B to CH2/B 	 <p>xx2000002053</p>
6	Insert the cabling through the cable support and fit the support to the drive board with the attachment screws.	 <p>xx2000002056</p> <p>Hex socket head cap screw: M3x30 12.9 Lafre 2C2B/FC6.9 (2 pcs) Tightening torque: 0.45 Nm.</p>  <p>xx2000002055</p>

Continues on next page

5 Repair

5.6.7 Replacing the axis-5 joint unit and the axis-5 to axis-6 transition cabling

Continued

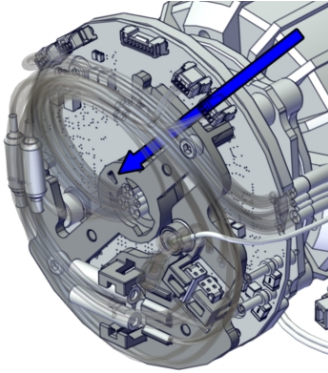
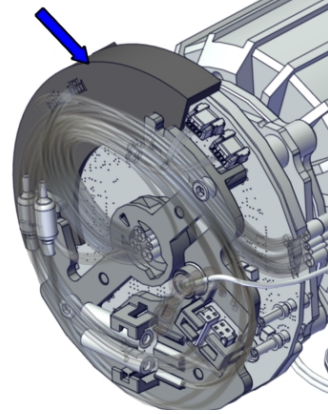
	Action	Note
7	Keep the cabling loose, making sure not to twist or strain it. Use the cable tie to pre-fix the cable by hand.	 xx2100000507
8	Fit the protection plate to the drive board unit.	Protection plate: 3HAC077790-001 (for CRB 15000-5/0.95) / 3HAC087789-001 (for CRB 15000-10/1.52 and CRB 15000-12/1.27)  xx2000002057

Continues on next page

5.6.7 Replacing the axis-5 joint unit and the axis-5 to axis-6 transition cabling
Continued

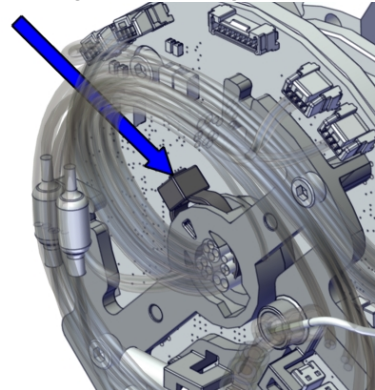
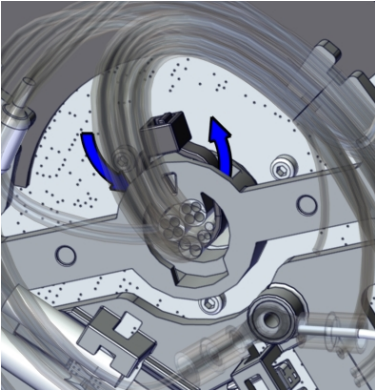
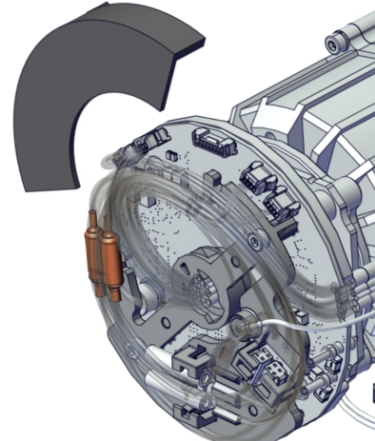
	Action	Note
9	<p>Secure the cables to the cable support with a cable tie, using a cable tie gun.</p> <p>Assembly direction for the cable tie is shown in the figure.</p>	<p>Cable tie: 3HAC075545-001. For securing joint unit cable.</p> <p>Cable tie gun EVO 7i</p> <p>Setting for cable tie gun: 6.75.</p>  <p>xx2000002058</p>  <p>xx2000002059</p>
10	<p>Remove the protection plate.</p>	 <p>xx2100000301</p>



Continues on next page

5 Repair

5.6.7 Replacing the axis-5 joint unit and the axis-5 to axis-6 transition cabling

Continued

Preparations before fitting the joint unit

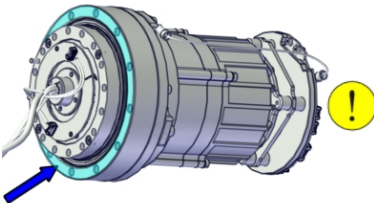
	Action	Note
1	 ELECTROSTATIC DISCHARGE (ESD) The unit is sensitive to ESD. Before handling the unit read the safety information in section <i>The unit is sensitive to ESD on page 53</i> .	
2	Clean the mounting surface of the joint unit and the mating surface on the casting with isopropanol. Joint unit mounting surface is pointed out in the figure.	Cleaning agent: Isopropanol Flange sealant: Loctite 574
3	Apply a thin layer of flange sealant to the mounting surface. Do not contaminate the radial sealing with sealant.  CAUTION The connectors and the joint unit cables are sensitive to mechanical damage. Handle the assembly with care.  ELECTROSTATIC DISCHARGE (ESD) The unit is sensitive to ESD. Before handling the unit read the safety information in section <i>The unit is sensitive to ESD on page 53</i> .	 xx2000001860

Refitting the axis-5 joint unit and transition cabling

	Action	Note
1	 CAUTION Axis-5 joint unit used for CRB 15000-5/0.95 has the same appearance as that used for CRB 15000-10/1.52 and CRB 15000-12/1.27. Do not mix the joint units for different manipulator variants. Always check the mark or label on the joint units before refitting.	

Continues on next page

5.6.7 Replacing the axis-5 joint unit and the axis-5 to axis-6 transition cabling
Continued

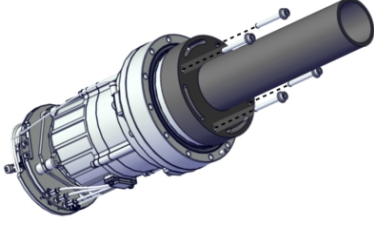
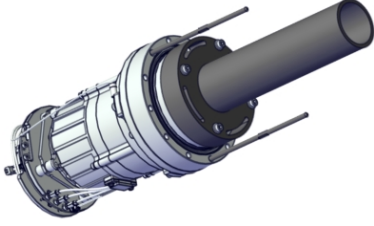
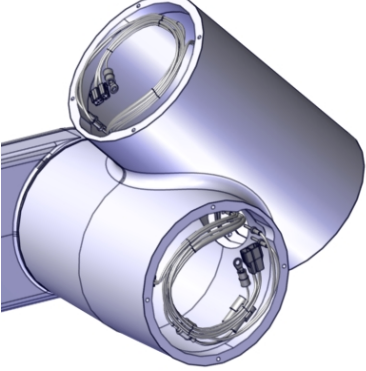

	Action	Note
2	<p>Fit the lifting aid to the joint unit.</p> <p> CAUTION</p> <p>The connectors and the joint unit cables are sensitive to mechanical damage. Handle the assembly with care.</p>	<p>Joint unit: 3HAC079143-001 (for CRB 15000-5/0.95) / 3HAC087546-001 (for CRB 15000-10/1.52 and CRB 15000-12/1.27)</p> <p>Lifting aid: 3HAC077789-001</p> <p>Screws: M3x12 (4 pcs)</p>  <p>xx2000001957</p>
3	<p>Fit two guide pins to the joint unit.</p>	<p>Guide pin, M3x110: 3HAC077787-001</p> <p>Always use guide pins in pairs.</p> <p>For joint units on axes 4, 5 and 6.</p>  <p>xx2000002438</p>
4	<p>Fit the transition cable between axis-5 and axis-6 joint units into the tilt.</p>	<p>Cable harness, transition joint-5 and joint-6: 3HAC083726-001</p>  <p>xx2100000040</p>

Continues on next page

5 Repair

5.6.7 Replacing the axis-5 joint unit and the axis-5 to axis-6 transition cabling

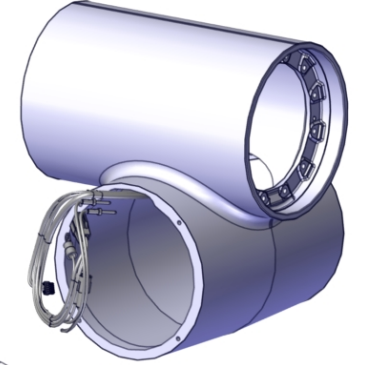
Continued

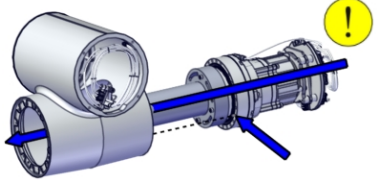
	Action	Note
5	Place the cabling at the slot before refitting the joint unit.	 <p data-bbox="1029 698 1136 719">xx210000041</p>  <p data-bbox="1029 1131 1136 1151">xx210000285</p>
6	<p data-bbox="481 1189 1016 1240">Fit the joint unit to the tilt, aligning the pin with the pin hole.</p> <p data-bbox="481 1263 687 1308"> CAUTION</p> <p data-bbox="481 1330 1016 1413">The connectors and the joint unit cables are sensitive to mechanical damage. Handle the assembly with care.</p>	 <p data-bbox="1029 1377 1136 1397">xx2000002142</p>

Continues on next page

5.6.7 Replacing the axis-5 joint unit and the axis-5 to axis-6 transition cabling

Continued

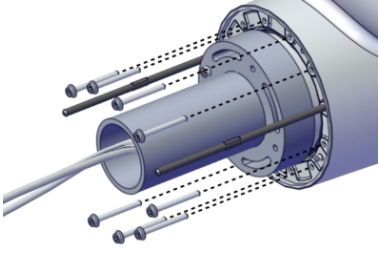
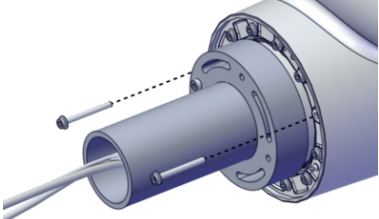
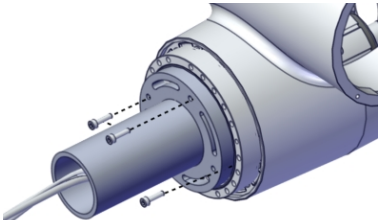
	Action	Note
7	Secure the joint unit with new attachment screws.	<p>Flange socket head screw with glue: 3HAB3413-330 M3x30 12.9 Lafre 2C2B/FC6.9+PrO-COat111, with NYPLAS glue , 12 pcs Used for joint unit of CRB 15000-5/0.95. Always use new screws when refitting a joint unit. If ordering a new joint unit spare part, new screws are included.</p>  <p>xx2100000333</p>
8	Remove the guide pins and secure the remaining two attachment screws.	 <p>xx2000002140</p>
9	Pre-tighten the screws crosswise.	
10	Torque tighten all screws crosswise.	<p>Tightening torque: 1.4 Nm (for CRB 15000-5/0.95) / 1.9 Nm (for CRB 15000-10/1.52 and CRB 15000-12/1.27)</p>
11	Remove the lifting aid by removing the screws.	 <p>xx2000002139</p>
12	Clean pushed-out flange sealant, if any.	

Continues on next page

5 Repair

5.6.7 Replacing the axis-5 joint unit and the axis-5 to axis-6 transition cabling

Continued

Connecting the axis-5 joint unit cabling

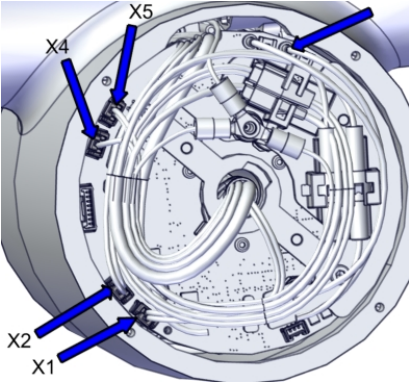
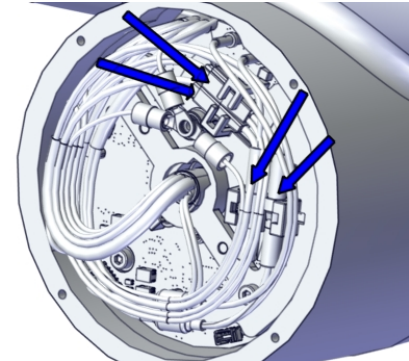
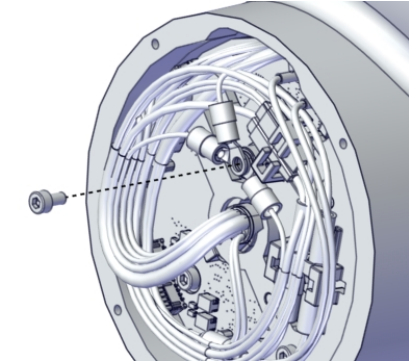
	Action	Note
1	<p>Reconnect the connectors to the drive board.</p> <ul style="list-style-type: none"> • D4/5.X1 to X1 • D5.DC+ to +DC • D5.DC- to Ground • D4/5.X4 to X4 • D5/4.X2 to X2 • D4/5.X5 to X5 	 <p>xx2000002138</p>
2	<p>Connect the connectors to each other and snap them to the cable holders.</p> <ul style="list-style-type: none"> • J5/6.DC+ to J6.DC+ • J5/6.DC- to J6.DC- • J5/6.CS to J6.CS • J5/6.CP to J6.CP 	 <p>xx2000002137</p>
3	<p>Secure the cables for functional earth and protective earth with a screw.</p>	<p>Hex socket head cap screw: M3x6 (1 pcs). Tightening torque: 0.8 Nm.</p>  <p>xx2000002136</p>

Continues on next page

5.6.7 Replacing the axis-5 joint unit and the axis-5 to axis-6 transition cabling
Continued

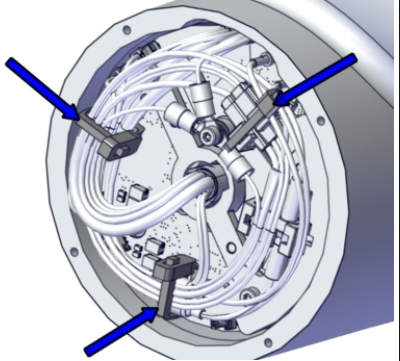
	Action	Note
4	Secure the cabling with cable ties.	Cable ties (3 pcs)  xx2000002135

Refitting the axis-5 cover

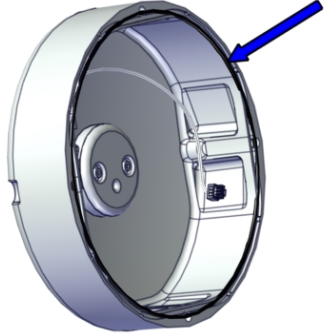
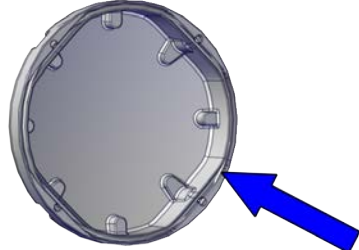
	Action	Note
1	Fit the o-ring to its groove. Replace if damaged.	Valid for CRB 15000-5/0.95 O-ring: 3HAC061327-051  xx2000001962 Valid for CRB 15000-10/1.52 and CRB 15000-12/1.27 O-ring: 3HAC061327-051  xx2300000849

Continues on next page

5 Repair

5.6.7 Replacing the axis-5 joint unit and the axis-5 to axis-6 transition cabling

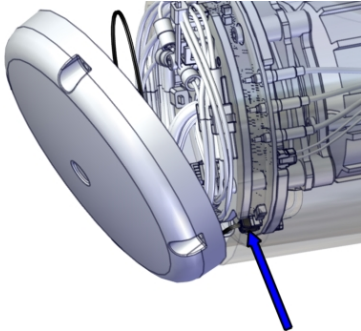
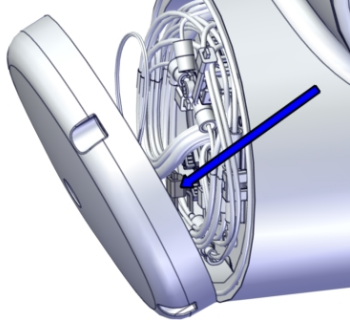
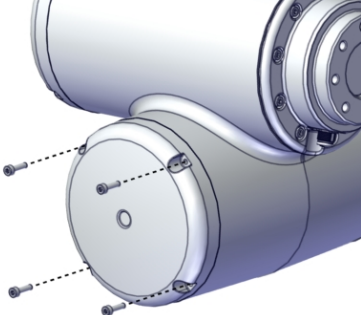

Continued

	Action	Note
2	<p>For robots with RobotWare earlier than 7.10 Place the cover at mounting position and reconnect the brake release connector DR.X8 to the drive board.</p>	 <p>xx2000002134</p>
3	<p>For robots with RobotWare earlier than 7.10 Secure the brake release cable with a cable tie.</p>	<p>Cable ties</p>  <p>xx2000002133</p>
4	<p>Refit the cover with the four screws.</p>	<p>Valid for CRB 15000-5/0.95 Hex socket head cap screw: M3x8 12.9 Lafre 2C2B/FC6.9 (4 pcs) Tightening torque: 0.2 Nm</p> <p>Valid for CRB 15000-10/1.52 and CRB 15000-12/1.27 Hex socket head cap screw: M3x12 12.9 Lafre 2C2B/FC6.9 (4 pcs) Tightening torque: 1.4 Nm</p>  <p>xx2000002132</p>

Continues on next page

5.6.7 Replacing the axis-5 joint unit and the axis-5 to axis-6 transition cabling
Continued

Preparations before fitting the joint unit

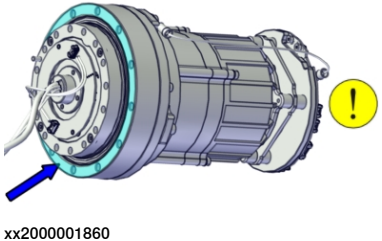
	Action	Note
1	 ELECTROSTATIC DISCHARGE (ESD) The unit is sensitive to ESD. Before handling the unit read the safety information in section <i>The unit is sensitive to ESD on page 53</i> .	
2	Clean the mounting surface of the joint unit and the mating surface on the casting with isopropanol. Joint unit mounting surface is pointed out in the figure.	Cleaning agent: Isopropanol Flange sealant: Loctite 574
3	Apply a thin layer of flange sealant to the mounting surface. Do not contaminate the radial sealing with sealant.  CAUTION The connectors and the joint unit cables are sensitive to mechanical damage. Handle the assembly with care.  ELECTROSTATIC DISCHARGE (ESD) The unit is sensitive to ESD. Before handling the unit read the safety information in section <i>The unit is sensitive to ESD on page 53</i> .	 <p>xx2000001860</p>

Refitting the axis-6 joint unit



	Action	Note
1	 CAUTION Axis-6 joint unit used for CRB 15000-5/0.95 has the same appearance as that used for CRB 15000-10/1.52 and CRB 15000-12/1.27. Do not mix the joint units for different manipulator variants. Always check the mark or label on the joint units before refitting.	

Continues on next page

5 Repair

5.6.7 Replacing the axis-5 joint unit and the axis-5 to axis-6 transition cabling

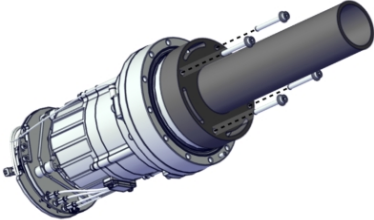
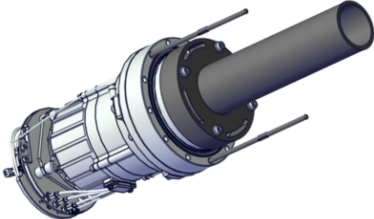
Continued

	Action	Note
2	<p>Fit the lifting aid to the joint unit.</p> <p> CAUTION</p> <p>The connectors and the joint unit cables are sensitive to mechanical damage. Handle the assembly with care.</p>	<p>Joint unit: 3HAC079143-001 (for CRB 15000-5/0.95) / 3HAC087546-001 (for CRB 15000-10/1.52 and CRB 15000-12/1.27)</p> <p>Lifting aid: 3HAC077789-001</p> <p>Screws: M3x12 (4 pcs)</p>  <p>xx2000001957</p>
3	<p>Fit two guide pins to the joint unit.</p>	<p>Guide pin, M3x110: 3HAC077787-001</p> <p>Always use guide pins in pairs.</p> <p>For joint units on axes 4, 5 and 6.</p>  <p>xx2000002438</p>
4	<p>Place the cabling at the slot before refitting the joint unit.</p>	 <p>xx2100000041</p>

Continues on next page

5.6.7 Replacing the axis-5 joint unit and the axis-5 to axis-6 transition cabling
Continued

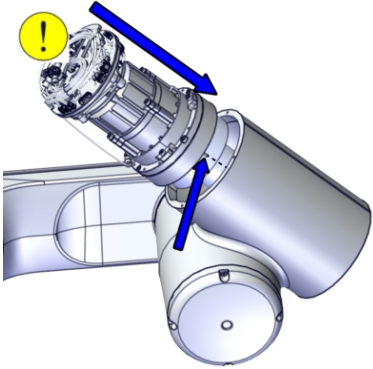
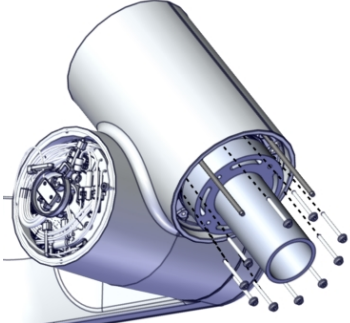
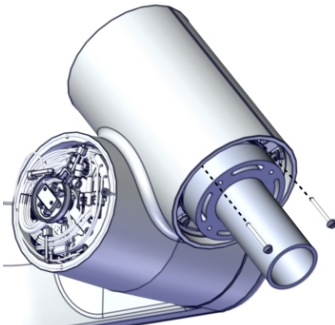
	Action	Note
5	Fit the joint unit to the tilt, aligning the pin with the pin hole.  CAUTION The connectors and the joint unit cables are sensitive to mechanical damage. Handle the assembly with care.	 xx2000002195
6	Secure the joint unit with new attachment screws.	Flange socket head screw with glue: 3HAB3413-330 M3x30 12.9 Lafre 2C2B/FC6.9+PrO-COat111, with NYPLAS glue , 12 pcs Used for joint unit of CRB 15000-5/0.95. Always use new screws when refitting a joint unit. If ordering a new joint unit spare part, new screws are included.  xx2100000329
7	Remove the guide pins and secure the remaining two attachment screws.	 xx2000002170
8	Pre-tighten the screws crosswise.	
9	Torque tighten all screws crosswise.	Tightening torque: 1.4 Nm (for CRB 15000-5/0.95) / 1.9 Nm (for CRB 15000-10/1.52 and CRB 15000-12/1.27)

Continues on next page

5 Repair

5.6.7 Replacing the axis-5 joint unit and the axis-5 to axis-6 transition cabling

Continued

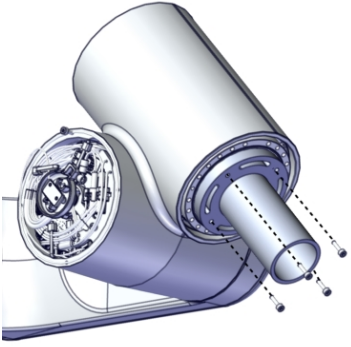
	Action	Note
10	Remove the lifting aid by removing the screws.	 <p data-bbox="1029 678 1136 698">xx2000002168</p>
11	Clean pushed-out flange sealant, if any.	

Connecting the axis-6 joint unit cabling

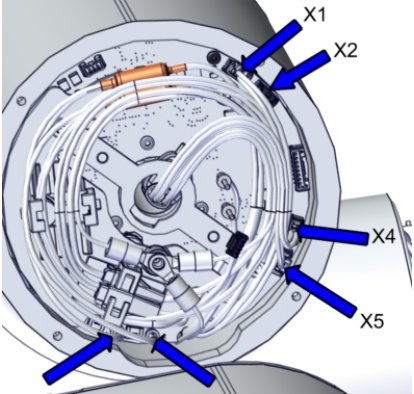
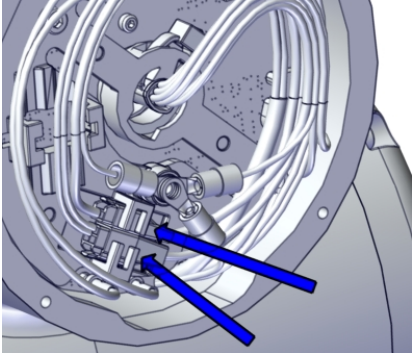
	Action	Note
1	Reconnect the connectors to the drive board. <ul style="list-style-type: none"> • D6.X1 to X1 • D6.DC+ to +DC • D6.DC- to Ground • D6.X4 to X4 • D6.X2 to X2 • D6.X5 to X5 	 <p data-bbox="994 1292 1101 1312">xx2000002164</p>
2	Connect the connectors to each other and snap them to the cable holders. <ul style="list-style-type: none"> • J7.CS to J7.CS • J7.CP to J7.CP 	 <p data-bbox="994 1706 1101 1727">xx2000002163</p>

Continues on next page

5.6.7 Replacing the axis-5 joint unit and the axis-5 to axis-6 transition cabling
Continued

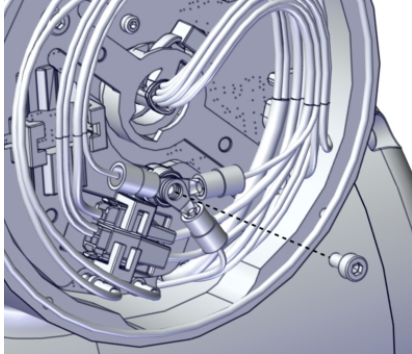
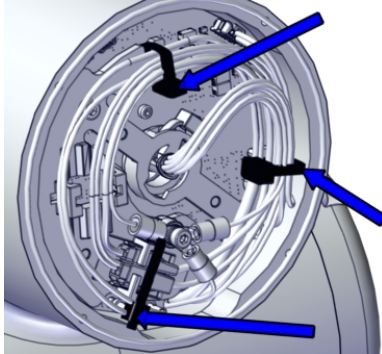
	Action	Note
3	Secure the cables for functional earth and protective earth with a screw.	<p>Hex socket head cap screw: M3x6 (1 pcs). Tightening torque: 0.8 Nm.</p>  <p>xx2000002162</p>
4	Secure the cabling with cable ties.	<p>Cable ties (3 pcs)</p>  <p>xx2000002161</p>

Refitting the arm-side interface

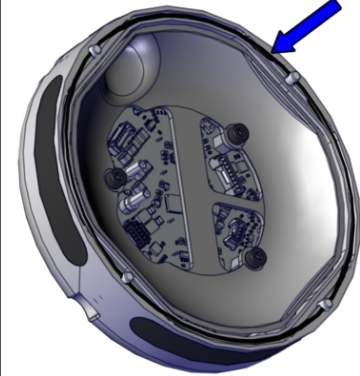
	Action	Note
1	Fit the o-ring to its groove. Replace if damaged.	<p>O-ring: 3HAC061327-051</p>  <p>xx2000002551</p>

Continues on next page

5 Repair

5.6.7 Replacing the axis-5 joint unit and the axis-5 to axis-6 transition cabling

Continued

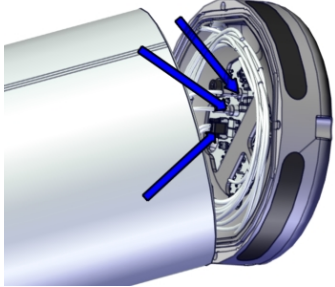
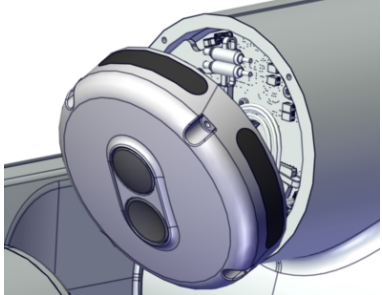
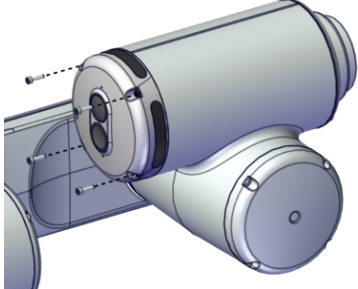
	Action	Note
2	<p>Place the arm-side interface at mounting position and reconnect the connectors.</p> <ul style="list-style-type: none"> • ASI.DC+ • ASI.DC- • ASI.X1 <p>The correct orientation of the arm-side interface is with the convex button in upper position.</p> <p> Note</p> <p>Do not leave the arm-side interface in location without being secured with the attachment screws.</p>	 <p>xx2100000335</p>  <p>xx2100000336</p>
3	<p>Refit the arm-side interface with four screws.</p>	<p>Valid for CRB 15000-5/0.95 Hex socket head cap screw: M3x30 12.9 Lafre 2C2B/FC6.9 (4 pcs) Tightening torque: 0.45 Nm</p> <p>Valid for CRB 15000-10/1.52 and CRB 15000-12/1.27 Hex socket head cap screw: M3x20 12.9 Lafre 2C2B/FC6.9 (4 pcs) Tightening torque: 0.45 Nm</p>  <p>xx2000002550</p>

Continues on next page

5.6.7 Replacing the axis-5 joint unit and the axis-5 to axis-6 transition cabling
Continued

Refitting the tool flange adapter

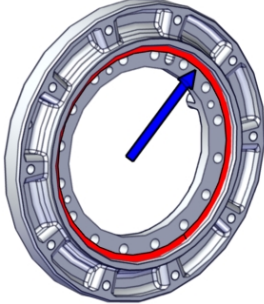
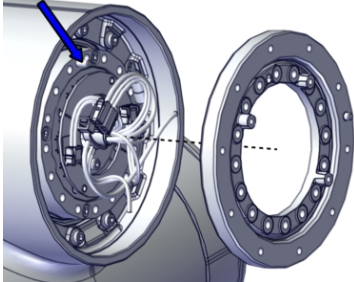
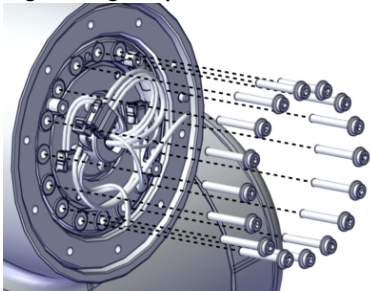
	Action	Note
1	Clean the mounting surface with isopropanol. Apply flange sealant to the corner of the adapter mounting surface, as pointed out in the figure.	<p>Cleaning agent: Isopropanol Flange sealant: Loctite 574</p>  <p>xx2000002196</p>
2	Refit the tool flange adapter, aligning the pin with the pin hole.	<p>Axis-6 inner flange: 3HAC073952-001</p>  <p>xx2000002167</p>
3	Secure with screws.	<p>Flange socket head screw: M3x20 12.9 Lafre 2C2B/FC6.9+PrO-COat111 (16 pcs) Tightening torque: 1.8 Nm.</p>  <p>xx2000002165</p>

Continues on next page

5 Repair

5.6.7 Replacing the axis-5 joint unit and the axis-5 to axis-6 transition cabling

Continued

Connecting the tool flange functional earth cable

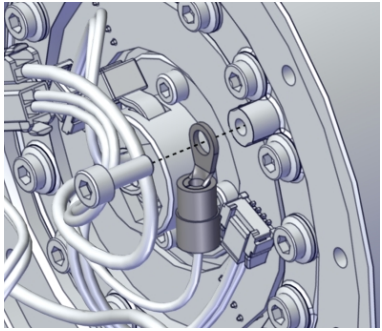
	Action	Note
1	Secure the cable for functional earth to the tool flange adapter with a screw.	 <p>xx2000002159</p>

Refitting the tool flange

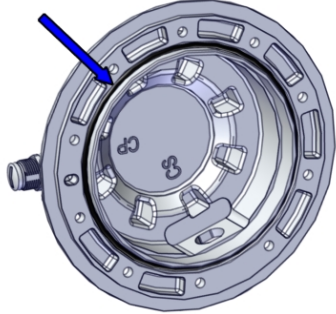
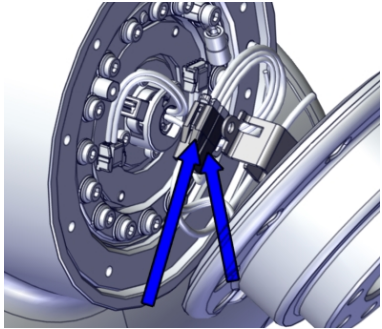
	Action	Note
1	Check the o-ring on the tool flange and lubricate with grease. Replace if damaged.	<p>Axis-6 flange: 3HAC073953-001 O-ring: 3HAB3772-182 Grease: 3HAC042536-001 (Shell Gadus S2)</p>  <p>xx2000002197</p>
2	Place the tool flange at mounting position and reconnect the CP/CS connectors.	 <p>xx2000002158</p>

Continues on next page

5.6.7 Replacing the axis-5 joint unit and the axis-5 to axis-6 transition cabling
Continued

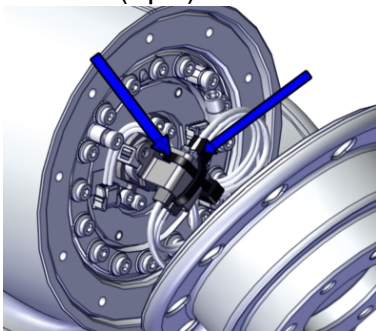
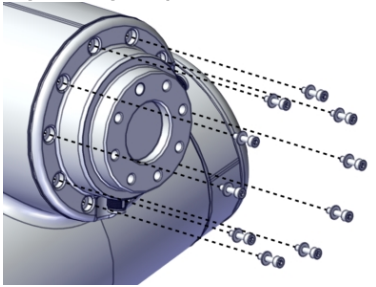
	Action	Note
3	Fit the connectors to the cable bracket and secure the connectors with two cable ties.	<p>Cable ties (2 pcs)</p>  <p>xx2000002157</p>
4	Refit and secure the tool flange with screws and washers.	<p>Hex socket head cap screw: M3x12 12.9 Lafre 2C2B/FC6.9 (10 pcs) Spring washer: 7x3.2x0.6 Steel (10 pcs) Tightening torque: 1.8 Nm.</p>  <p>xx2000002155</p>

Refitting the tilt

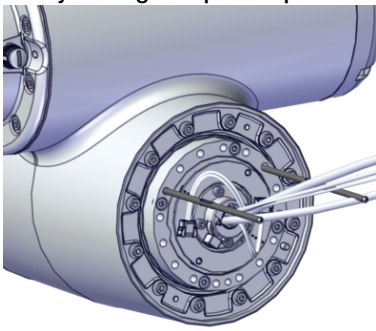
	Action	Note
1	Fit two guide pins to the axis-5 joint.	<p>Guide pin, M3x110: 3HAC077787-001 Always use guide pins in pairs.</p>  <p>xx2000002146</p>

Continues on next page

5 Repair

5.6.7 Replacing the axis-5 joint unit and the axis-5 to axis-6 transition cabling

Continued

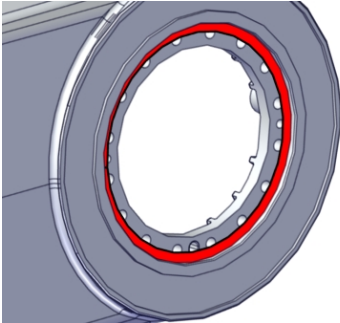
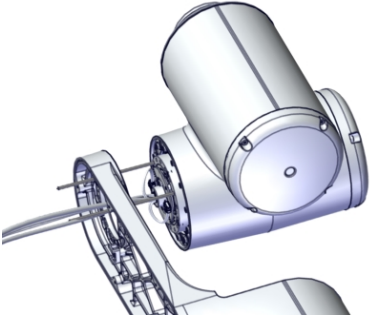
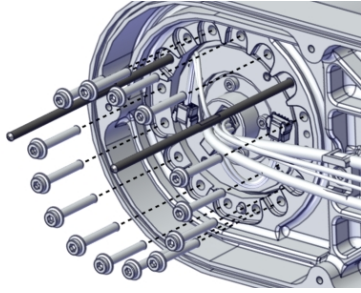
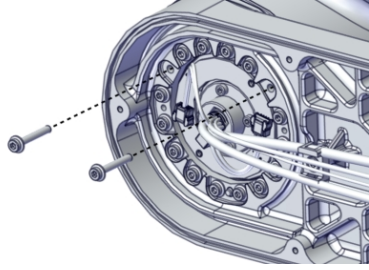
	Action	Note
2	Clean the mounting surface with isopropanol. Apply flange sealant to the corner of the tubular mounting surface, as pointed out in the figure.	<p>Cleaning agent: Isopropanol Flange sealant: Loctite 574</p>  <p>xx2000002147</p>
3	Lift the tilt into mounting position while inserting the cabling into the tubular.	 <p>xx2000002131</p>
4	Slide the tilt into place on the guide pins.	
5	Secure the tilt to the tubular with all attachment screws but two. Pre-tighten the screws crosswise firstly.	<p>Flange socket head screw: M3x20 12.9 Lafre 2C2B/FC6.9+PrO-COat111 (14 pcs)</p>  <p>xx2000002130</p>
6	Remove the guide pins and fasten the remaining two screws.	<p>Flange socket head screw: M3x20 12.9 Lafre 2C2B/FC6.9+PrO-COat111 (2 pcs)</p>  <p>xx2000002128</p>
7	Torque tighten all screws crosswise.	Tightening torque: 1.8 Nm.

Continues on next page

5.6.7 Replacing the axis-5 joint unit and the axis-5 to axis-6 transition cabling
Continued

Connecting the tilt cabling

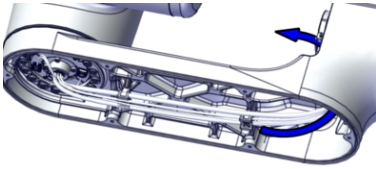
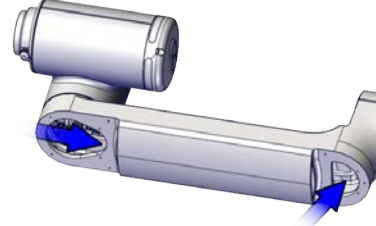
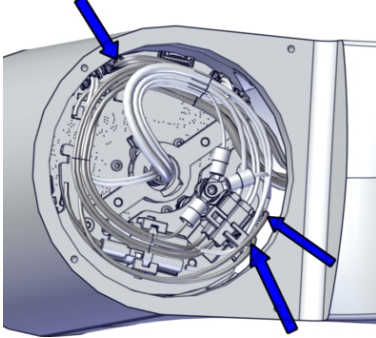
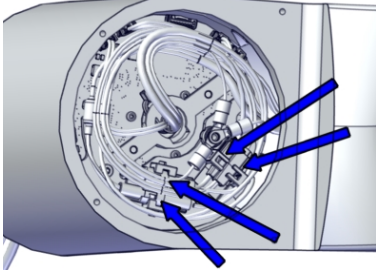
	Action	Note
1	Insert the cabling into the tubular.	<p>Valid for CRB 15000-5/0.95</p>  <p>xx2000002148</p> <p>Valid for CRB 15000-10/1.52 and CRB 15000-12/1.27</p>  <p>xx2300000845</p>
2	<p>Reconnect the connectors to the drive board.</p> <ul style="list-style-type: none"> • D3/4.X2 to X2 • D3/4.DC- to Ground • D3/4.DC+ to +DC 	 <p>xx2000002125</p>
3	<p>Connect the connectors to each other and snap them to the cable holders.</p> <ul style="list-style-type: none"> • J4/5.DC+ to J5/6.DC+ • J4/5.DC- to J5/6.DC- • J4/5.CS to J5/6.CS • J4/5.CP to J5/6.CP 	 <p>xx2000002089</p>

Continues on next page

5 Repair

5.6.7 Replacing the axis-5 joint unit and the axis-5 to axis-6 transition cabling

Continued

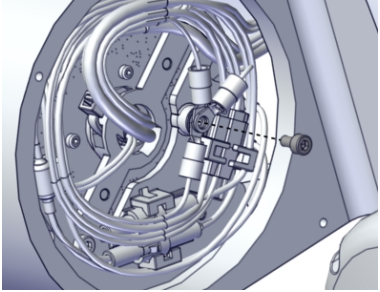
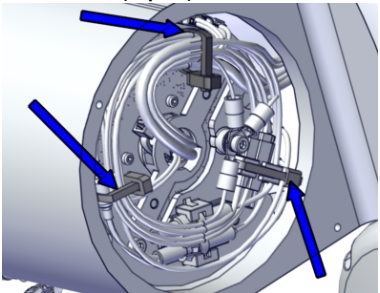
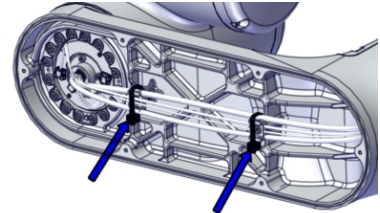
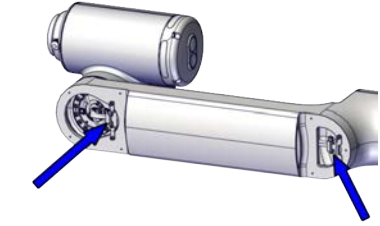
	Action	Note
4	Secure the cables for functional earth and protective earth with a screw.	<p>Hex socket head cap screw: M3x6 (1 pcs). Tightening torque: 0.8 Nm.</p>  <p>xx2000002087</p>
5	Secure the cabling to joint unit with cable ties.	<p>Cable ties (3 pcs)</p>  <p>xx2000002086</p>
6	Secure the cabling to tubular with cable ties.	<p>Cable ties (2 pcs) Valid for CRB 15000-5/0.95</p>  <p>xx2000002124</p> <p>Valid for CRB 15000-10/1.52 and CRB 15000-12/1.27</p>  <p>xx2300000842</p>

Continues on next page

5.6.7 Replacing the axis-5 joint unit and the axis-5 to axis-6 transition cabling
Continued

Refitting the tubular cover (-5/0.95)

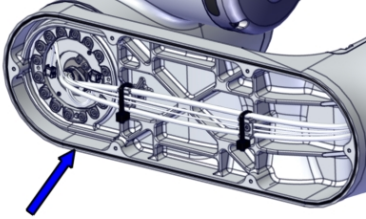
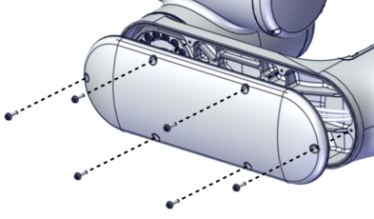
	Action	Note
1	Wipe, lubricate and fit the o-ring to its groove. Replace if damaged.	<p>O-ring: 3HAC061327-043 Grease: 3HAC042536-001 (Shell Gadus S2)</p>  <p>xx2000002149</p>
2	Refit the cover with new attachment screws.	<p>Flange socket head screw with glue: 3HAB3413-312 M3x12 12.9 Lafre 2C2B/FC6.9+PrO-COat111, with NYPLAS glue For tubular cover of CRB 15000-5/0.95. Always use new screws. If ordering a new axis-4 or axis-5 joint unit spare part, new screws for the tubular cover are included. Tightening torque: 1.6 Nm.</p>  <p>xx2000002123</p>

Continues on next page

5 Repair

5.6.7 Replacing the axis-5 joint unit and the axis-5 to axis-6 transition cabling

Continued

Refitting the tubular cover (-10/1.52 and -12/1.27)

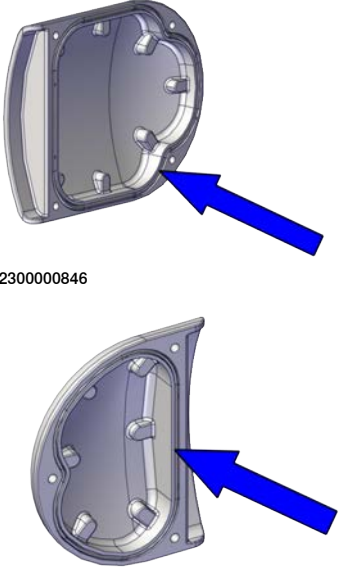
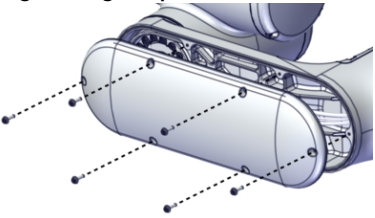
	Action	Note
1	Wipe, lubricate and fit the o-ring to its groove. Replace if damaged.	<p>O-ring: 3HAC061327-076 O-ring: 3HAB3772-166 Grease: 3HAC042536-001 (Shell Gadus S2)</p>  <p>xx2300000846</p> <p>xx2300000847</p>
2	Refit the covers with new attachment screws.	<p>Hex socket head cap screw: 3HAB3409-224 M3x12 12.9 Lafre 2C2B/FC6.9 (3 pcs) Tightening torque: 1.4 Nm.</p>  <p>xx2000002123</p>

Continues on next page

5.6.7 Replacing the axis-5 joint unit and the axis-5 to axis-6 transition cabling
Continued

Refitting the axis-4 cover

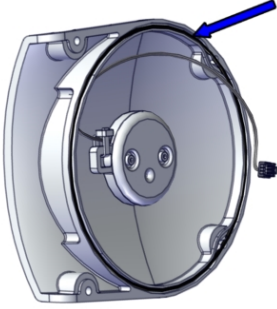
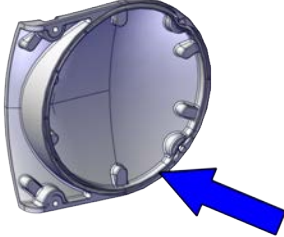
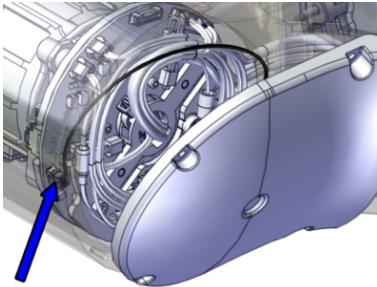
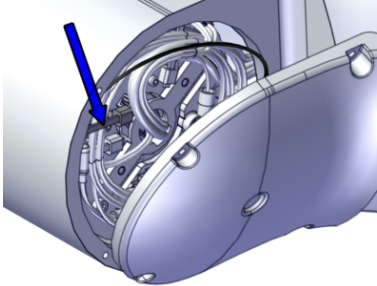
	Action	Note
1	Fit the o-ring to its groove. Replace if damaged.	<p>Valid for CRB 15000-5/0.95 O-ring: 3HAC061327-051</p>  <p>xx2000002092</p> <p>Valid for CRB 15000-10/1.52 and CRB 15000-12/1.27 O-ring: 3HAC061327-051</p>  <p>xx2300000848</p>
2	For robots with RobotWare earlier than 7.10 Place the cover at mounting position and reconnect the brake release connector DR.X8 to the drive board.	<p>Tweezers</p>  <p>xx2000002085</p>
3	For robots with RobotWare earlier than 7.10 Secure the brake release cable with a cable tie.	<p>Cable ties</p>  <p>xx2000002084</p>

Continues on next page

5 Repair

5.6.7 Replacing the axis-5 joint unit and the axis-5 to axis-6 transition cabling

Continued

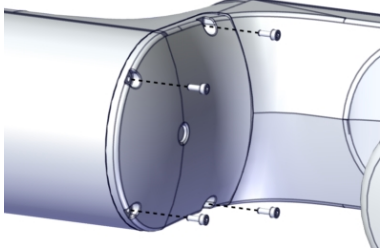
	Action	Note
4	Refit the cover with the four screws.	<p>Hex socket head cap screw: M3x8 12.9 Lafre 2C2B/FC6.9 (4 pcs)</p> <p>Tightening torque: 0.2 Nm (for CRB 15000-5/0.95) / 0.9 Nm (for CRB 15000-10/1.52 and CRB 15000-12/1.27)</p> <p>Tightening torque: 0.9 Nm</p>  <p>xx2000002083</p>

Concluding procedure

	Action	Note
1	<p>Calibrate the joint unit torque sensor.</p> <ol style="list-style-type: none"> 1 On the FlexPendant, go to the Code app and call the calibration procedure using PP to Routine, not by using Call Routine. 2 Select the Joint Unit Replacement feature and then select the axis to calibrate. 3 The controller is now restarted. Once the home screen of the FlexPendant is shown, press the Play button to continue the calibration routine. 4 The robot moves to a position or positions where measurements are performed. 5 The results of the measurements are presented together with the current values in the controller. Choose whether to save the calibration data or not. 6 If new calibration data is saved you will be asked to do a test with the lead-through functionality active to verify that the sensors work correctly. 7 Finally the robot is moved back to the original position. 8 Test the brake release (movement without drive power) functionality, see Testing the brake release functionality on page 196. 	See Calibration on page 1063
2	 <p>DANGER</p> <p>Make sure all safety requirements are met when performing the first test run. See Test run after installation, maintenance, or repair on page 90.</p>	

5.6.8 Replacing the axis-6 joint unit

Location of the axis-6 joint unit

The joint unit is located as shown in the figure.

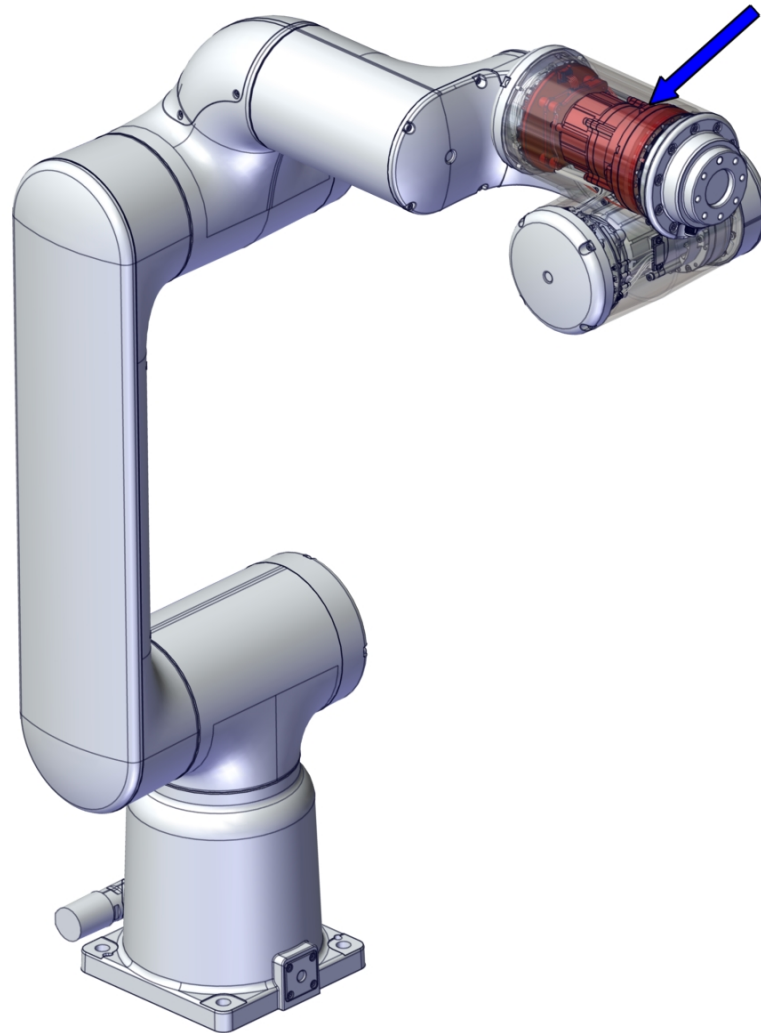

xx2000002122

Summary of the replacement procedure

This is a brief summary of the replacement procedure, containing the major actions to be performed.

- 1 Remove the tool flange.
- 2 Remove the tool flange adapter.
- 3 Remove the axis-6 cover.
- 4 Replace the joint unit. Move the cabling from old to new joint unit.

Continues on next page

5 Repair

5.6.8 Replacing the axis-6 joint unit

Continued

Required spare parts



Note

The spare part numbers that are listed in the table can be out of date. See the latest spare parts of the CRB 15000 via myABB Business Portal, www.abb.com/myABB.

Spare part	Article number	Note
Joint unit	3HAC079143-001	Used for CRB 15000-5/0.95. New attachment screws and cable tie 3HAC075545-001 are included in the delivery.
Joint unit	3HAC087546-001	New attachment screws and cable tie 3HAC075545-001 are included in the delivery.

Required tools and equipment

Equipment	Article number	Note
Lifting aid	3HAC077789-001	For joint units on axes 4, 5 and 6. Attachment screws M3x12 (4 pcs) are enclosed.
Guide pin, M3x110	3HAC077787-001	Always use guide pins in pairs. For joint units on axes 4, 5 and 6.
Protection plate	3HAC077790-001	For protection of drive board during cabling installation on joint units of CRB 15000-5/0.95.
Protection plate	3HAC087789-001	For protection of drive board during cabling installation on joint units of CRB 15000-10/1.52 and CRB 15000-12/1.27.
Cable tie gun EVO 7i	-	HellermannTyton 110-77001 or similar
Tweezers	-	Used to handle drive board connectors.
Standard toolkit	-	Content is defined in section Standard toolkit on page 1099 .

Required consumables



Consumable	Article number	Note
Cleaning agent	-	Isopropanol
Flange sealant	-	Loctite 574
Grease	3HAC042536-001	Shell Gadus S2
O-ring	3HAB3772-182	Tool flange
O-ring	3HAC061327-051	Arm-side interface Replace if damaged.
Cable ties	-	

Continues on next page

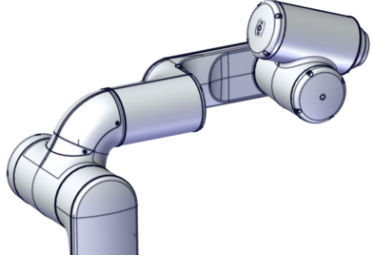

Removing the joint unit

Use these procedures to remove the joint unit.

Preparations before removing the joint unit

	Action	Note
1	<p>Jog the robot to the specified position:</p> <ul style="list-style-type: none"> • Axis 1: No significance. • Axis 2: No significance. • Axis 3: No significance. • Axis 4: No significance. • Axis 5: approximately +20° • Axis 6: 0° (home position) <p> CAUTION</p> <p>Jog the axis on which the joint unit is to be replaced to home position, to achieve correct cable routing during replacement of the joint unit.</p>	<p>Example of CRB 15000-5/0.95, similar to CRB 15000-10/1.52 and CRB 15000-12/1.27.</p>  <p>xx2100000043</p>
2	<p> CAUTION</p> <p>Turn off all supplies for electrical power to the robot, before starting the repair work.</p>	

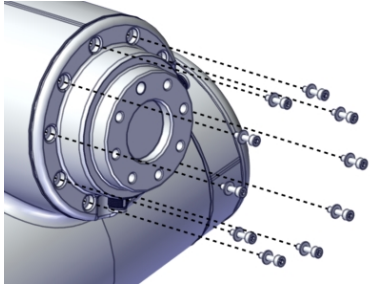
Removing the tool flange

	Action	Note
1	<p>Remove the tool flange screws and washers.</p>	 <p>xx2000002155</p>
2	<p> CAUTION</p> <p>Valid for CRB 15000-5/0.95</p> <p>There is cabling connected between the cover and the joint unit drive board.</p> <p>Open the cover with care to avoid damage to the cabling or the connector(s).</p> <p>Do not leave the cover in location without being secured with the attachment screws.</p>	

Continues on next page

5 Repair

5.6.8 Replacing the axis-6 joint unit

Continued

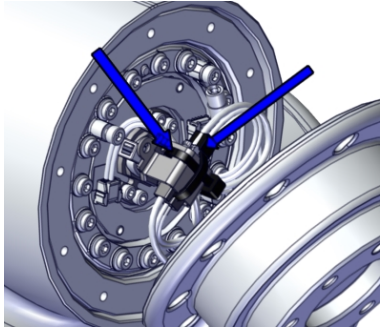
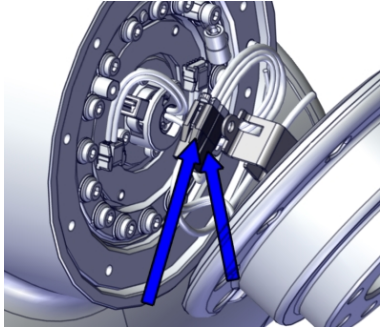
	Action	Note
3	Cut the cable ties.	 <p>xx2000002157</p>
4	Disconnect the CP/CS connectors from the drive board and remove the tool flange.	 <p>xx2000002158</p>

Disconnecting the tool flange functional earth cable

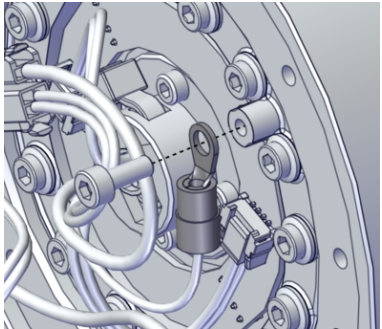
	Action	Note
1	Remove the functional earth cable by removing the screw.	 <p>xx2000002159</p>

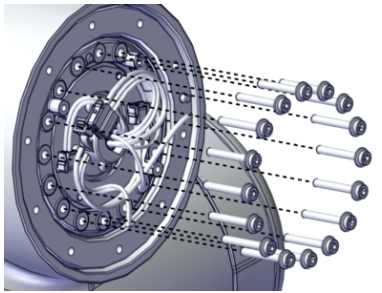

Removing the tool flange adapter

	Action	Note
1	Remove the tool flange adapter screws.	 <p>xx2000002165</p>

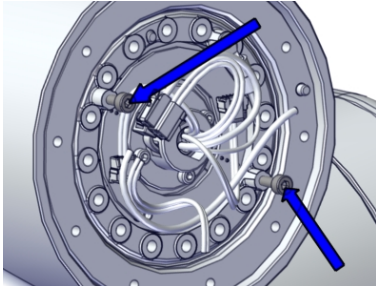
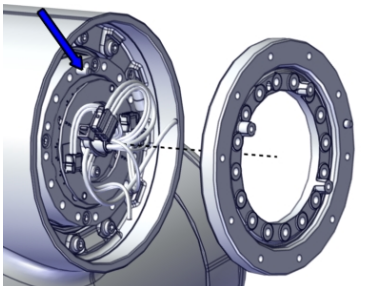
Continues on next page

	Action	Note
2	Press the adapter out of position by using two of the attachment screws as removal tools.	 <p>xx2000002166</p>
3	Remove the tool flange adapter.	 <p>xx2000002167</p>

Removing the arm-side interface

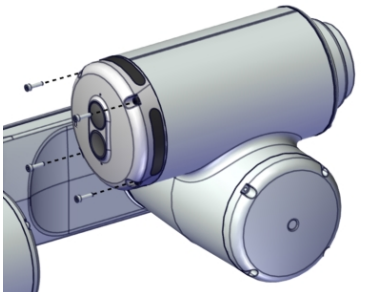
	Action	Note
1	 CAUTION Make sure that all supplies for electrical power are turned off.	
2	 CAUTION There is cabling connected between the arm-side interface and the joint unit drive board. Open the arm-side interface with care to avoid damage to the cabling or the connector(s). Do not leave the arm-side interface in location without being secured with the attachment screws.	
3	Remove the attachment screws.	 <p>xx2000002550</p>

Continues on next page

5 Repair

5.6.8 Replacing the axis-6 joint unit

Continued

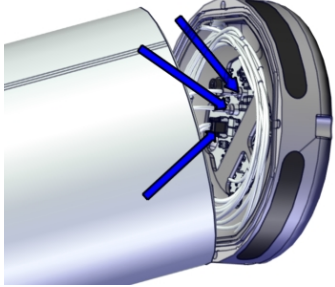
	Action	Note
4	<p>Loosen the arm-side interface carefully and disconnect the connectors from it.</p> <ul style="list-style-type: none">• ASI.DC+• ASI.DC-• ASI.X1	 <p>xx2100000335</p>

Disconnecting the axis-6 joint unit cabling

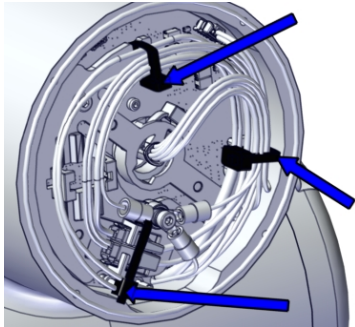
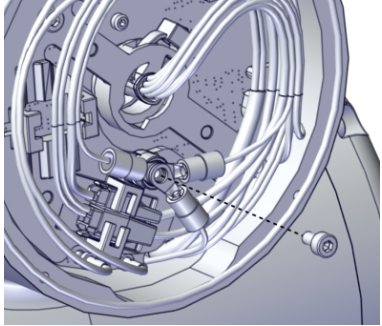
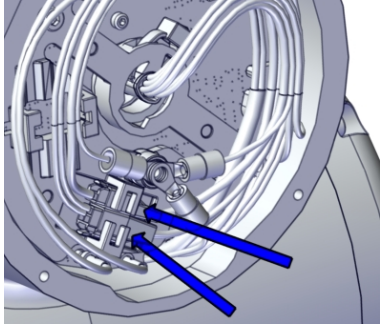
	Action	Note
1	Cut the cable ties.	 <p>xx2000002161</p>
2	Remove the functional and protective earth cables by removing the screw.	 <p>xx2000002162</p>
3	<p>Snap loose and disconnect the connectors:</p> <ul style="list-style-type: none">• J7.CS• J7.CP	 <p>xx2000002163</p>

Continues on next page

5.6.8 Replacing the axis-6 joint unit
Continued

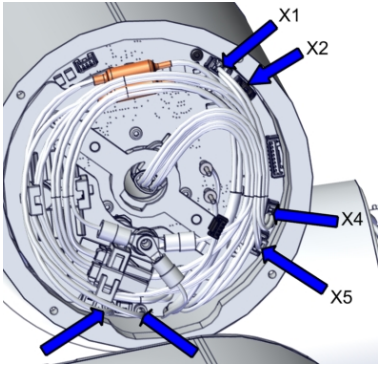
	Action	Note
4	<p>Disconnect the connectors from the drive board.</p> <ul style="list-style-type: none"> • D6.X1 • D6.DC+ • D6.DC- • D6.X4 • D6.X2 • D6.X5 <p> CAUTION</p> <p>Use tweezers to unlock connectors and pull them off.</p>	<p>Tweezers</p>  <p>xx2000002164</p>

Removing the axis-6 joint unit

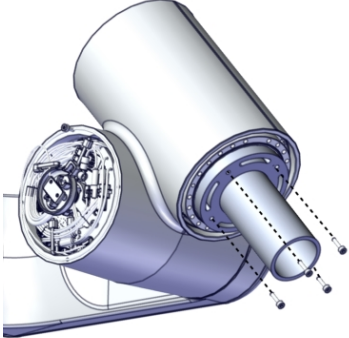
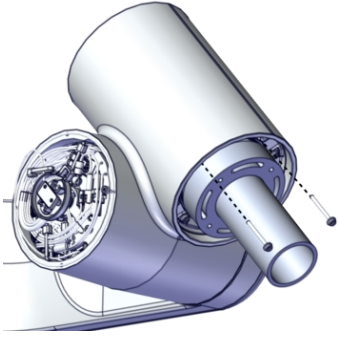
	Action	Note
1	<p>Fit the lifting aid to the joint unit, on the torque sensor side.</p> <p> CAUTION</p> <p>The connectors and the joint unit cables are sensitive to mechanical damage. Handle the assembly with care.</p>	<p>Lifting aid: 3HAC077789-001 Screws: M3x12 (4 pcs)</p>  <p>xx2000002168</p> <p>Position shown in the figure shows axis 5 jogged to +20°, which is a more convenient position when replacing only the axis-6 joint unit.</p>
2	<p>Remove two attachment screws. Dispose the screws. New screws are included in the spare part delivery of the joint unit.</p>	 <p>xx2000002170</p> <p>Position shown in the figure shows axis 5 jogged to +20°, which is a more convenient position when replacing only the axis-6 joint unit.</p>

Continues on next page

5 Repair

5.6.8 Replacing the axis-6 joint unit

Continued

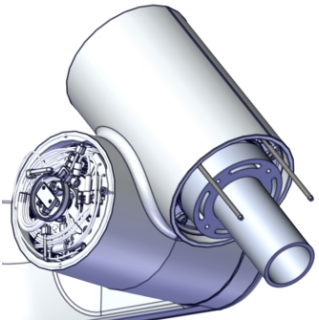
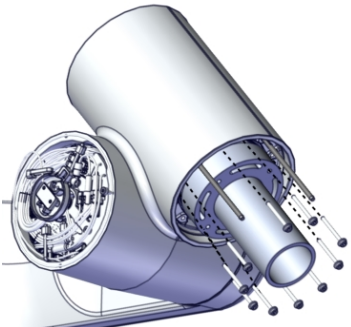
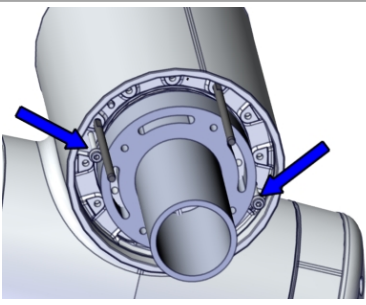
	Action	Note
3	Fit two guide pins to the axis-6 joint unit.	<p>Guide pin, M3x110: 3HAC077787-001</p> <p>Always use guide pins in pairs.</p> <p>For joint units on axes 4, 5 and 6.</p>  <p>xx2100000328</p>
4	<p>Remove the remaining attachment screws.</p> <p>Use two screws as press out screws in the upcoming step, then dispose all screws.</p> <p>New screws are included in the spare part delivery of the joint unit.</p>	 <p>xx2100000329</p>
5	Press the joint unit out of position using two of the previous attachment screws as removal tools.	 <p>xx2100000330</p>

Continues on next page

5.6.8 Replacing the axis-6 joint unit
Continued

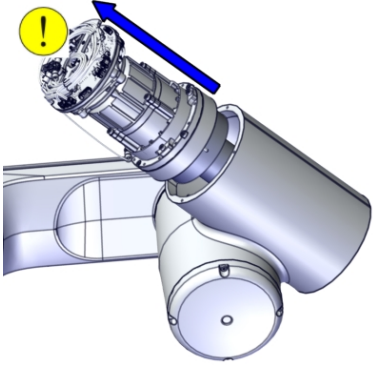
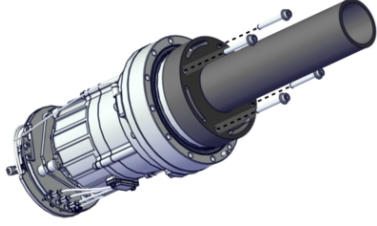
	Action	Note
6	<p>Remove the joint unit from the tubular.</p> <p> CAUTION</p> <p>The connectors and the joint unit cables are sensitive to mechanical damage. Handle the assembly with care.</p>	 <p>xx2000002169</p> <p>Position shown in the figure shows axis 5 jogged to +20°, which is a more convenient position when replacing only the axis-6 joint unit.</p>
7	<p>Remove the lifting aid and guide pins.</p>	 <p>xx2000001957</p>

Removing the joint cable



	Action	Note
1	<p> ELECTROSTATIC DISCHARGE (ESD)</p> <p>The unit is sensitive to ESD. Before handling the unit read the safety information in section The unit is sensitive to ESD on page 53.</p>	

Continues on next page

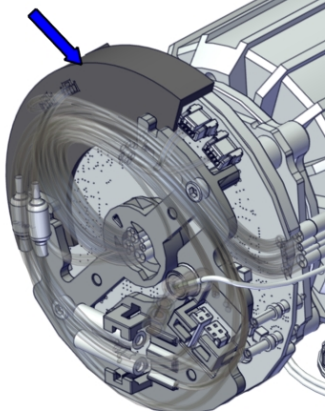

5 Repair

5.6.8 Replacing the axis-6 joint unit

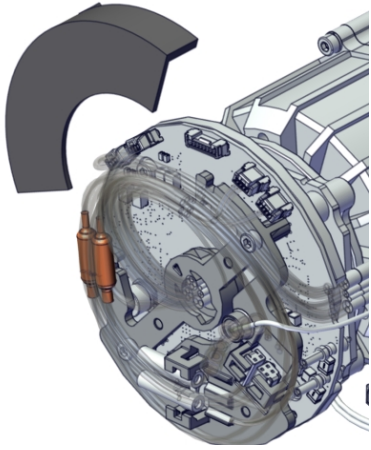
Continued

	Action	Note
2	<p>Fit the protection plate to the drive board unit.</p> <p> Tip</p> <p>Using the protection plate is important for protecting the drive board unit. If complete joint unit is to be replaced, the protection plate is not needed.</p>	<p>Protection plate: 3HAC077790-001 (for CRB 15000-5/0.95) / 3HAC087789-001 (for CRB 15000-10/1.52 and CRB 15000-12/1.27)</p>  <p>xx2000002057</p>
3	<p>Cut the cable tie at the drive board.</p>	 <p>xx2000002058</p>
4	<p>Remove the protection plate.</p>	 <p>xx2100000301</p>

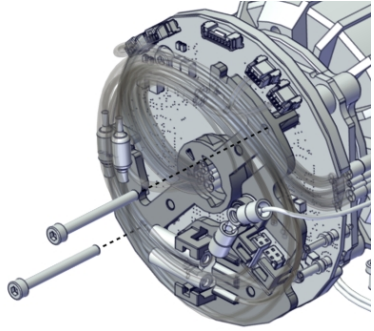
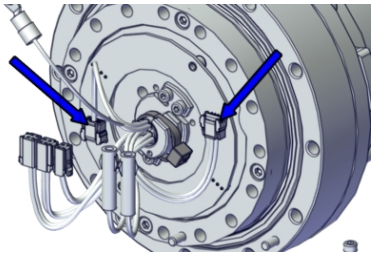
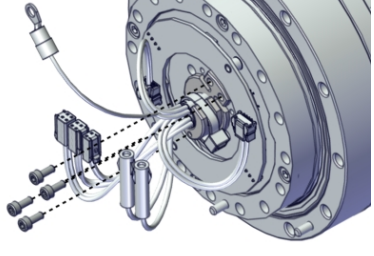
Continues on next page

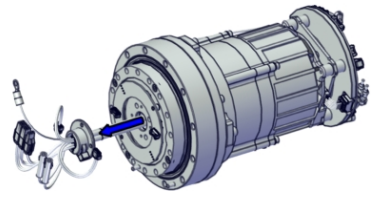
	Action	Note
5	Remove the cable support from the drive board by removing the attachment screws.	 <p>xx2000002055</p>
6	Disconnect the two connectors from the torque sensor board. <ul style="list-style-type: none"> • TQ.A • TQ.B 	 <p>xx2000002053</p>
7	Remove the cable plate by removing the attachment screws.	 <p>xx2000002049</p>
8	Remove the joint cable from the hollow shaft from the torque sensor side.  CAUTION The connectors and the joint unit cables are sensitive to mechanical damage. Handle the assembly with care.	 <p>xx2000002060</p>

Refitting the joint unit

Use these procedures to refit the joint unit.

Refitting the joint cable

	Action	Note
1	 ELECTROSTATIC DISCHARGE (ESD) The unit is sensitive to ESD. Before handling the unit read the safety information in section The unit is sensitive to ESD on page 53 .	

Continues on next page

5 Repair

5.6.8 Replacing the axis-6 joint unit

Continued

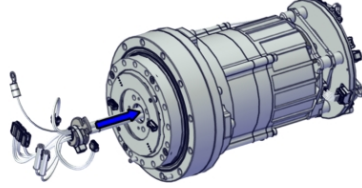
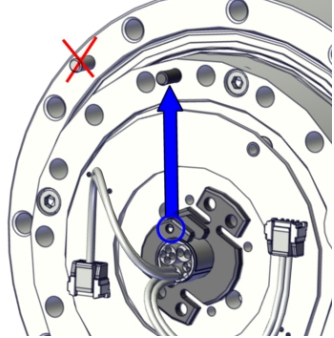
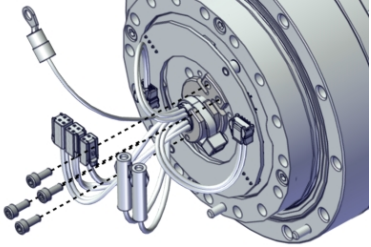
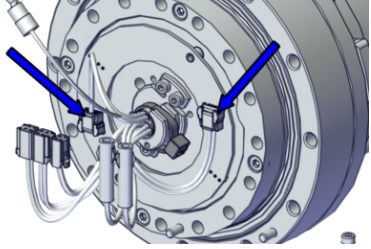
	Action	Note
2	<p>Place the joint cable through the hollow shaft from the torque sensor side.</p> <p> CAUTION</p> <p>The connectors and the joint unit cables are sensitive to mechanical damage. Handle the assembly with care.</p>	 <p>xx2000002048</p>
3	<p>Orient the cable plate according to the figure. The circle on the cable plate should point towards the guide pin on the torque sensor.</p>	 <p>xx2000002051</p>
4	<p>Secure the cable plate to the joint unit with the attachment screws.</p>	<p>Hex socket head cap screw: M2.5x6 12.9 Lafre 2C2B/FC6.9 (4 pcs)</p> <p>Tightening torque: 0.45 Nm.</p>  <p>xx2000002049</p>
5	<p>Connect the two connectors to the torque sensor board.</p> <ul style="list-style-type: none"> • TQ.A to CH1/A • TQ.B to CH2/B 	 <p>xx2000002053</p>

Continues on next page

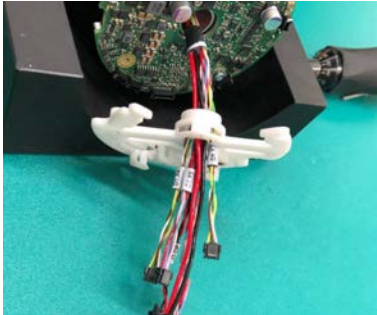
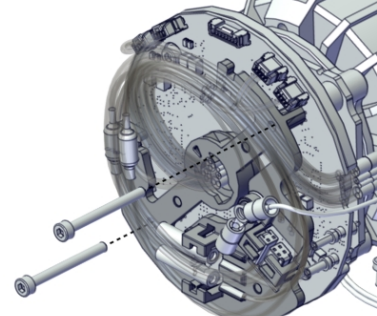
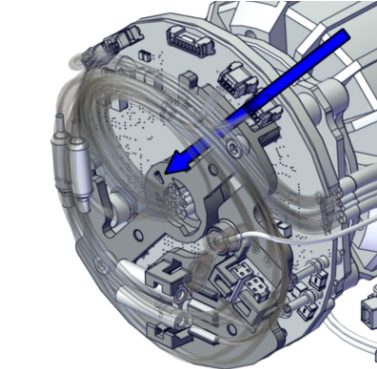

	Action	Note
6	<p>Insert the cabling through the cable support and fit the support to the drive board with the attachment screws.</p>	 <p>xx2000002056</p> <p>Hex socket head cap screw: M3x30 12.9 Lafre 2C2B/FC6.9 (2 pcs) Tightening torque: 0.45 Nm.</p>  <p>xx2000002055</p>
7	<p>Keep the cabling loose, making sure not to twist or strain it. Use the cable tie to pre-fix the cable by hand.</p>	 <p>xx2100000507</p>

Continues on next page

5 Repair

5.6.8 Replacing the axis-6 joint unit

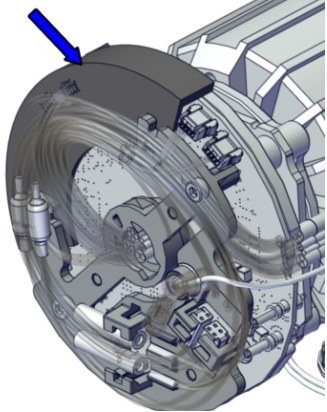

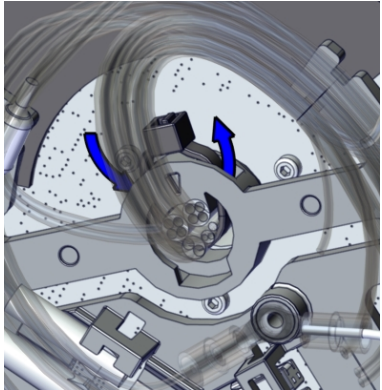
Continued

	Action	Note
8	Fit the protection plate to the drive board unit.	<p>Protection plate: 3HAC077790-001 (for CRB 15000-5/0.95) / 3HAC087789-001 (for CRB 15000-10/1.52 and CRB 15000-12/1.27)</p>  <p>xx2000002057</p>
9	Secure the cables to the cable support with a cable tie, using a cable tie gun. Assembly direction for the cable tie is shown in the figure.	<p>Cable tie: 3HAC075545-001. For securing joint unit cable. Cable tie gun EVO 7i Setting for cable tie gun: 6.75.</p>  <p>xx2000002058</p>  <p>xx2000002059</p>

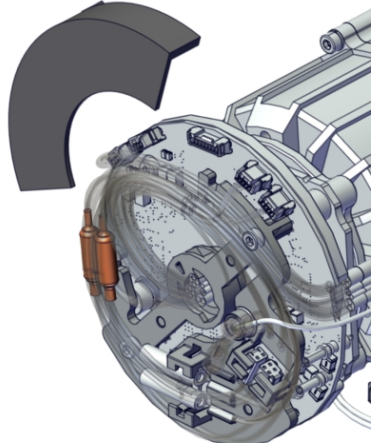
Continues on next page

	Action	Note
10	Remove the protection plate.	 <p>xx2100000301</p>

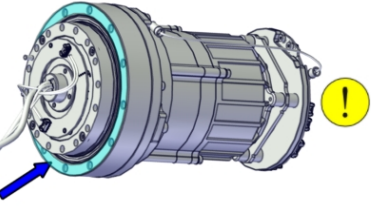
Preparations before fitting the joint unit

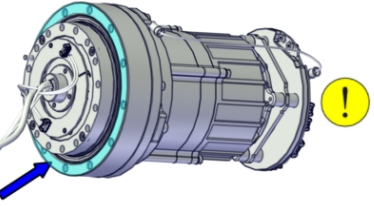
	Action	Note
1	 <p>ELECTROSTATIC DISCHARGE (ESD)</p> <p>The unit is sensitive to ESD. Before handling the unit read the safety information in section The unit is sensitive to ESD on page 53.</p>	
2	<p>Clean the mounting surface of the joint unit and the mating surface on the casting with isopropanol.</p> <p>Joint unit mounting surface is pointed out in the figure.</p>	<p>Cleaning agent: Isopropanol Flange sealant: Loctite 574</p> 
3	<p>Apply a thin layer of flange sealant to the mounting surface. Do not contaminate the radial sealing with sealant.</p> <p> CAUTION</p> <p>The connectors and the joint unit cables are sensitive to mechanical damage. Handle the assembly with care.</p> <p> ELECTROSTATIC DISCHARGE (ESD)</p> <p>The unit is sensitive to ESD. Before handling the unit read the safety information in section The unit is sensitive to ESD on page 53.</p>	 <p>xx2000001860</p>





Continues on next page

5 Repair

5.6.8 Replacing the axis-6 joint unit

Continued

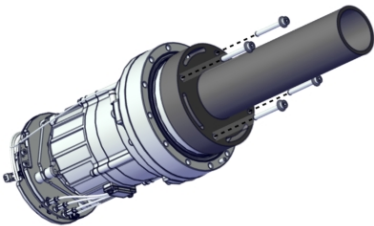
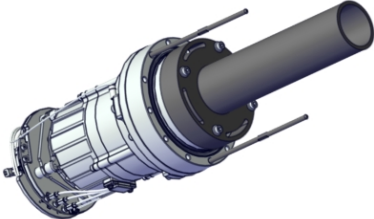
Refitting the axis-6 joint unit

	Action	Note
1	 CAUTION Axis-6 joint unit used for CRB 15000-5/0.95 has the same appearance as that used for CRB 15000-10/1.52 and CRB 15000-12/1.27. Do not mix the joint units for different manipulator variants. Always check the mark or label on the joint units before refitting.	
2	Fit the lifting aid to the joint unit.  CAUTION The connectors and the joint unit cables are sensitive to mechanical damage. Handle the assembly with care.	Joint unit: 3HAC079143-001 (for CRB 15000-5/0.95) / 3HAC087546-001 (for CRB 15000-10/1.52 and CRB 15000-12/1.27) Lifting aid: 3HAC077789-001 Screws: M3x12 (4 pcs)  <small>xx2000001957</small>
3	Fit two guide pins to the joint unit.	Guide pin, M3x110: 3HAC077787-001 Always use guide pins in pairs. For joint units on axes 4, 5 and 6.  <small>xx2000002438</small>
4	Place the cabling at the slot before refitting the joint unit.	 <small>xx2100000041</small>

Continues on next page

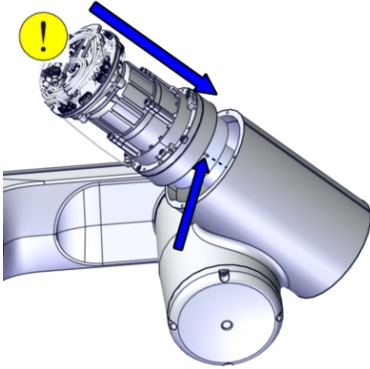
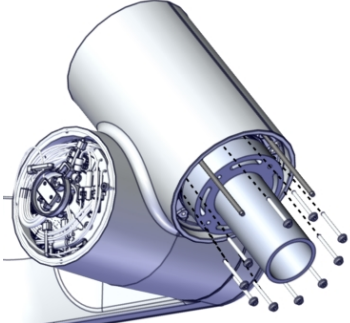
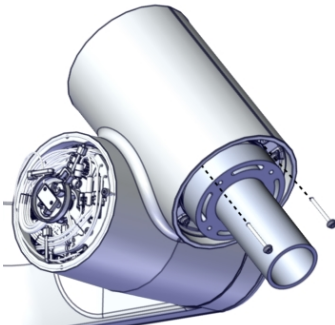
	Action	Note
5	<p>Fit the joint unit to the tilt, aligning the pin with the pin hole.</p> <p> CAUTION</p> <p>The connectors and the joint unit cables are sensitive to mechanical damage. Handle the assembly with care.</p>	 <p>xx2000002195</p>
6	<p>Secure the joint unit with new attachment screws.</p>	<p>Flange socket head screw with glue: 3HAB3413-330 M3x30 12.9 Lafre 2C2B/FC6.9+PrO-COat111, with NYPLAS glue , 12 pcs Used for joint unit of CRB 15000-5/0.95. Always use new screws when refitting a joint unit. If ordering a new joint unit spare part, new screws are included.</p>  <p>xx2100000329</p>
7	<p>Remove the guide pins and secure the remaining two attachment screws.</p>	 <p>xx2000002170</p>
8	<p>Pre-tighten the screws crosswise.</p>	
9	<p>Torque tighten all screws crosswise.</p>	<p>Tightening torque: 1.4 Nm (for CRB 15000-5/0.95) / 1.9 Nm (for CRB 15000-10/1.52 and CRB 15000-12/1.27)</p>

Continues on next page

5 Repair

5.6.8 Replacing the axis-6 joint unit

Continued

	Action	Note
10	Remove the lifting aid by removing the screws.	 <p>xx2000002168</p>
11	Clean pushed-out flange sealant, if any.	

Connecting the axis-6 joint unit cabling

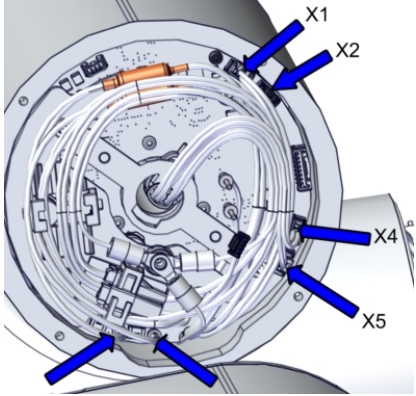
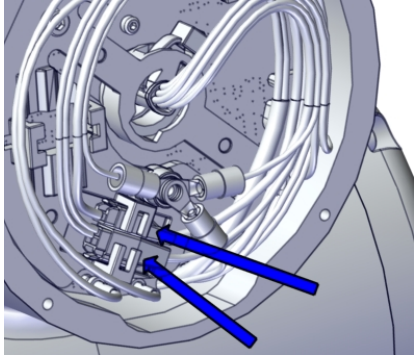
	Action	Note
1	Reconnect the connectors to the drive board. <ul style="list-style-type: none"> • D6.X1 to X1 • D6.DC+ to +DC • D6.DC- to Ground • D6.X4 to X4 • D6.X2 to X2 • D6.X5 to X5 	 <p>xx2000002164</p>
2	Connect the connectors to each other and snap them to the cable holders. <ul style="list-style-type: none"> • J7.CS to J7.CS • J7.CP to J7.CP 	 <p>xx2000002163</p>

Continues on next page

5.6.8 Replacing the axis-6 joint unit

Continued

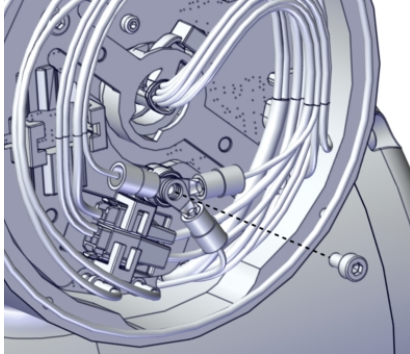
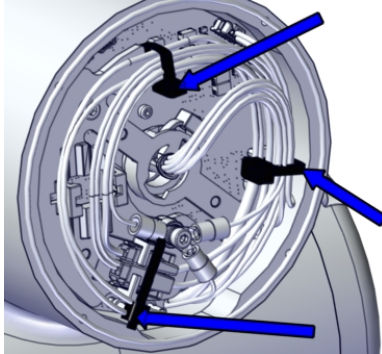
	Action	Note
3	Secure the cables for functional earth and protective earth with a screw.	<p>Hex socket head cap screw: M3x6 (1 pcs). Tightening torque: 0.8 Nm.</p>  <p>xx2000002162</p>
4	Secure the cabling with cable ties.	<p>Cable ties (3 pcs)</p>  <p>xx2000002161</p>

Refitting the arm-side interface

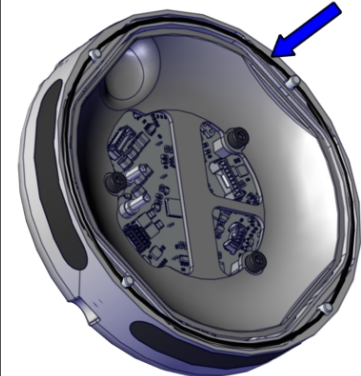
	Action	Note
1	Fit the o-ring to its groove. Replace if damaged.	<p>O-ring: 3HAC061327-051</p>  <p>xx2000002551</p>

Continues on next page

5 Repair

5.6.8 Replacing the axis-6 joint unit

Continued

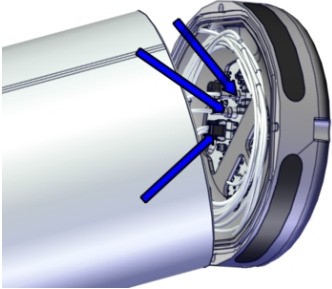
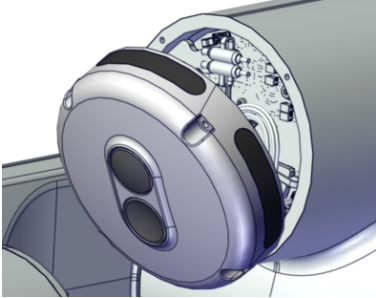
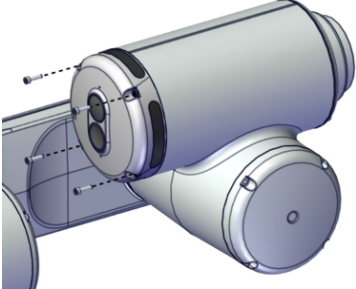
	Action	Note
2	<p>Place the arm-side interface at mounting position and reconnect the connectors.</p> <ul style="list-style-type: none">• ASI.DC+• ASI.DC-• ASI.X1 <p>The correct orientation of the arm-side interface is with the convex button in upper position.</p> <p> Note</p> <p>Do not leave the arm-side interface in location without being secured with the attachment screws.</p>	 <p>xx2100000335</p>  <p>xx2100000336</p>
3	Refit the arm-side interface with four screws.	<p>Valid for CRB 15000-5/0.95 Hex socket head cap screw: M3x30 12.9 Lafre 2C2B/FC6.9 (4 pcs) Tightening torque: 0.45 Nm</p> <p>Valid for CRB 15000-10/1.52 and CRB 15000-12/1.27 Hex socket head cap screw: M3x20 12.9 Lafre 2C2B/FC6.9 (4 pcs) Tightening torque: 0.45 Nm</p>  <p>xx2000002550</p>

Continues on next page

Refitting the tool flange adapter

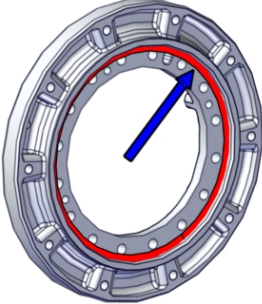
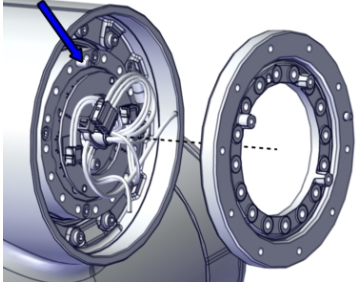
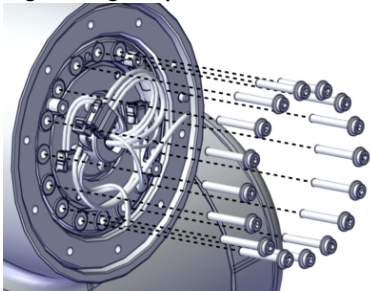
	Action	Note
1	Clean the mounting surface with isopropanol. Apply flange sealant to the corner of the adapter mounting surface, as pointed out in the figure.	<p>Cleaning agent: Isopropanol Flange sealant: Loctite 574</p>  <p>xx2000002196</p>
2	Refit the tool flange adapter, aligning the pin with the pin hole.	<p>Axis-6 inner flange: 3HAC073952-001</p>  <p>xx2000002167</p>
3	Secure with screws.	<p>Flange socket head screw: M3x20 12.9 Lafre 2C2B/FC6.9+PrO-COat111 (16 pcs) Tightening torque: 1.8 Nm.</p>  <p>xx2000002165</p>

Continues on next page

5 Repair

5.6.8 Replacing the axis-6 joint unit

Continued

Connecting the tool flange functional earth cable

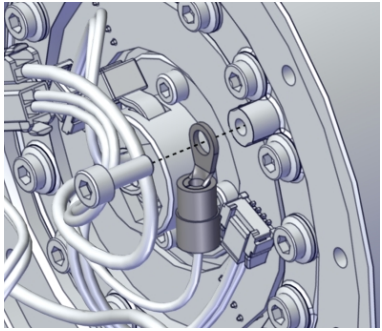
	Action	Note
1	Secure the cable for functional earth to the tool flange adapter with a screw.	 xx2000002159

Refitting the tool flange

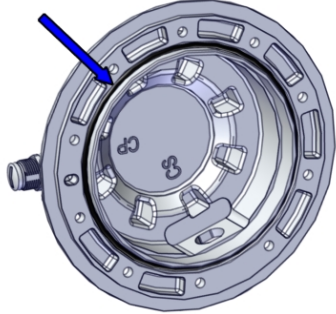
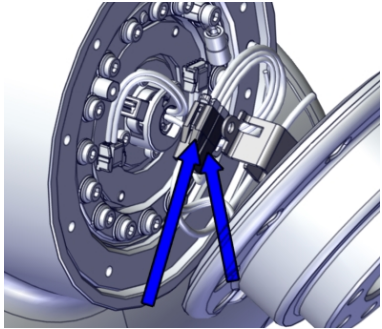
	Action	Note
1	Check the o-ring on the tool flange and lubricate with grease. Replace if damaged.	Axis-6 flange: 3HAC073953-001 O-ring: 3HAB3772-182 Grease: 3HAC042536-001 (Shell Gadus S2)  xx2000002197
2	Place the tool flange at mounting position and reconnect the CP/CS connectors.	 xx2000002158

Continues on next page

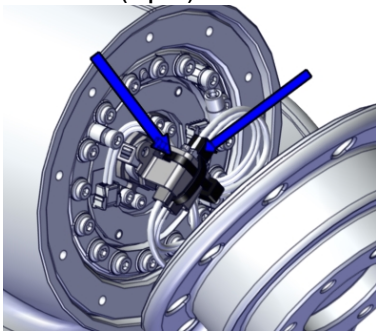
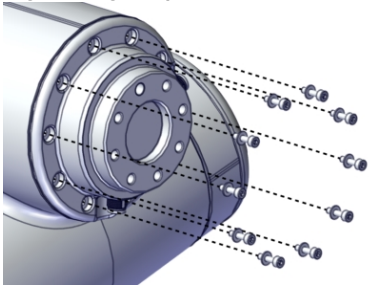
	Action	Note
3	Fit the connectors to the cable bracket and secure the connectors with two cable ties.	<p>Cable ties (2 pcs)</p>  <p>xx2000002157</p>
4	Refit and secure the tool flange with screws and washers.	<p>Hex socket head cap screw: M3x12 12.9 Lafre 2C2B/FC6.9 (10 pcs) Spring washer: 7x3.2x0.6 Steel (10 pcs) Tightening torque: 1.8 Nm.</p>  <p>xx2000002155</p>

Continues on next page

5 Repair

5.6.8 Replacing the axis-6 joint unit

Continued

Concluding procedure

	Action	Note
1	<p>Calibrate the joint unit torque sensor.</p> <ol style="list-style-type: none">1 On the FlexPendant, go to the Code app and call the calibration procedure using PP to Routine, not by using Call Routine.2 Select the Joint Unit Replacement feature and then select the axis to calibrate.3 The controller is now restarted. Once the home screen of the FlexPendant is shown, press the Play button to continue the calibration routine.4 The robot moves to a position or positions where measurements are performed.5 The results of the measurements are presented together with the current values in the controller. Choose whether to save the calibration data or not.6 If new calibration data is saved you will be asked to do a test with the lead-through functionality active to verify that the sensors work correctly.7 Finally the robot is moved back to the original position.8 Test the brake release (movement without drive power) functionality, see Testing the brake release functionality on page 196.	See Calibration on page 1063
2	<p> DANGER</p> <p>Make sure all safety requirements are met when performing the first test run. See Test run after installation, maintenance, or repair on page 90.</p>	

6 Calibration

6.1 Calibration methods

Overview

This section specifies the different types of calibration and the calibration methods that are supplied by ABB.

Types of calibration

Type of calibration	Description	Calibration method
Absolute accuracy calibration (optional)	<p>Based on standard calibration, and besides positioning the robot at synchronization position, the Absolute accuracy calibration also compensates for:</p> <ul style="list-style-type: none"> Mechanical tolerances in the robot structure Deflection due to load <p>Absolute accuracy calibration focuses on positioning accuracy in the Cartesian coordinate system for the robot.</p> <p>Absolute accuracy calibration data is found on the serial measurement board (SMB) or other robot memory.</p> <p>A robot calibrated with Absolute accuracy has the option information printed on its name plate (OmniCore).</p> <p>To regain 100% Absolute accuracy performance, the robot must be recalibrated for absolute accuracy after repair or maintenance that affects the mechanical structure.</p>	CalibWare
Torque sensor calibration	<p>The CRB 15000 torque sensors are calibrated with the routine TorqueSensorCal which is available in the System Module TorqueSensorCalib. No external calibration tools are required.</p> <p>The calibration method for the robot consists of calibrating the motor torque sensors, which are installed to monitor and measure the motor torque.</p>	Torque sensor calibration
Optimization	<p>Optimization of TCP reorientation performance. The purpose is to improve reorientation accuracy for continuous processes like welding and gluing.</p> <p>Wrist optimization will update standard calibration data for axes 4 and 5.</p>	Wrist Optimization

Brief description of calibration methods

Torque sensor calibration

The torque sensor in an axis motor must be calibrated if any of the following situations occur:

- A drift in the sensor values has occurred.

Continues on next page

6 Calibration

6.1 Calibration methods

Continued

This is shown on the FlexPendant as error code 90549 **Torque sensor check failure** or 34334 **Arm side torque sensor error**.

- A joint unit has been replaced.
- Repair work that involves removal and refitting of the joint units, has been performed.
- After heavy collisions or uncontrolled stops. This does not apply to collisions or stops which may routinely be experienced as part of a power and force limiting application.

No calibration is needed at site at robot installation.

The torque sensor routine only works on floor mounted robots.



Tip

When designing the robot cell, run the torque sensor routine in RobotStudio to verify that the path and pose are obtainable in the planned design.

Wrist Optimization method

Wrist Optimization is a method for improving reorientation accuracy for continuous processes like welding and gluing.

The actual instructions of how to perform the wrist optimization procedure is given on the FlexPendant.

CalibWare - Absolute Accuracy calibration

The CalibWare tool guides through the calibration process and calculates new compensation parameters. This is further detailed in the *Application manual - CalibWare Field*.

If a service operation is done to a robot with the option Absolute Accuracy, a new absolute accuracy calibration is required in order to establish full performance. For most cases after replacements that do not include taking apart the robot structure, standard calibration is sufficient.

The Absolute Accuracy option varies according to the robot mounting position. This is printed on the robot name plate for each robot. The robot must be in the correct mounting position when it is recalibrated for absolute accuracy.

References

Article numbers for the calibration tools are listed in the section [Special tools on page 1100](#).

6.2 Calibrating the torque sensors

Torque sensor calibration routine

The CRB 15000 torque sensors are calibrated with the routine `TorqueSensorCal`, which is available in the **System Module** `TorqueSensorCalib`. No external calibration tools are required.

Features in the routine

The routine for the torque sensor calibration includes the following features:

Feature	Description
Torque Sensor Check	This feature compares the current torque sensor offsets with measured offsets. This is useful for a quick test of the calibration.
Torque Sensor Calibⁱ	This feature calibrates torque sensors when a sensor drift has occurred. This is useful, for example, if there are event log messages about a sensor drift, or if there is a drift when using lead-through.
Joint Unit Replacementⁱ	This feature calibrates torque sensors when a joint unit has been exchanged, or when a joint has been removed as part of replacing another part.

ⁱ This feature is only available when user authorization (UAS) is set with user grant **Safety Services**.

Preparations before calibration

Remove any tools mounted on the robot, to get accurate torque offsets measurements.

The torque sensor calibration routine must be run in manual operating mode.

Running the calibration routine is possible only if the logged in user has the the grant **Safety Services**.

Running routine `TorqueSensorCal`

The actual instructions of how to perform the calibration procedure and what to do at each step is given on the FlexPendant. You will be guided through the calibration procedure, step by step.



CAUTION

Keep a distance from the robot while the routine is running, until the calibration data has been reviewed, accepted as reasonable, and stored.

- 1 On the FlexPendant, go to the **Code** app and call the calibration procedure **Torque Sensor Calib**, using **PP to Routine**, not by using **Call Routine**. Press **Play**.

- 2 Select which feature to run.

The features are described in [Features in the routine on page 1065](#).

Only the feature **Torque Sensor Check** is shown for users without user grant **Safety Services**.

The other features require a password. The password is 14775 (cannot be changed).

- 3 Select which axis to calibrate.

Continues on next page

6 Calibration

6.2 Calibrating the torque sensors

Continued

- 4 For the **Joint Unit Replacement** feature, the controller will now restart. Once the home screen of the FlexPendant is shown, press the Play button to continue the calibration routine.
- 5 The robot moves to a position or positions where measurements are performed.
- 6 The results of the measurements are presented together with the current values in the controller. Choose whether to save the calibration data or not. If the calibration data is saved, the new sensor offsets are saved in a file called `TSENS_LOG.TXT` in the **HOME** directory.
- 7 If new calibration data is saved you will be asked to do a test with the lead-through functionality active to verify that the sensors work correctly.
- 8 Finally the robot is moved back to the original position.



Tip

If the **Joint Unit Replacement** feature has been run, there is no need to run any of the other features.

6.3 Jogging directions

Illustration of axis jogging directions

The figure shows the positive and negative directions for each axis when jogging the robot in the base coordinate system.

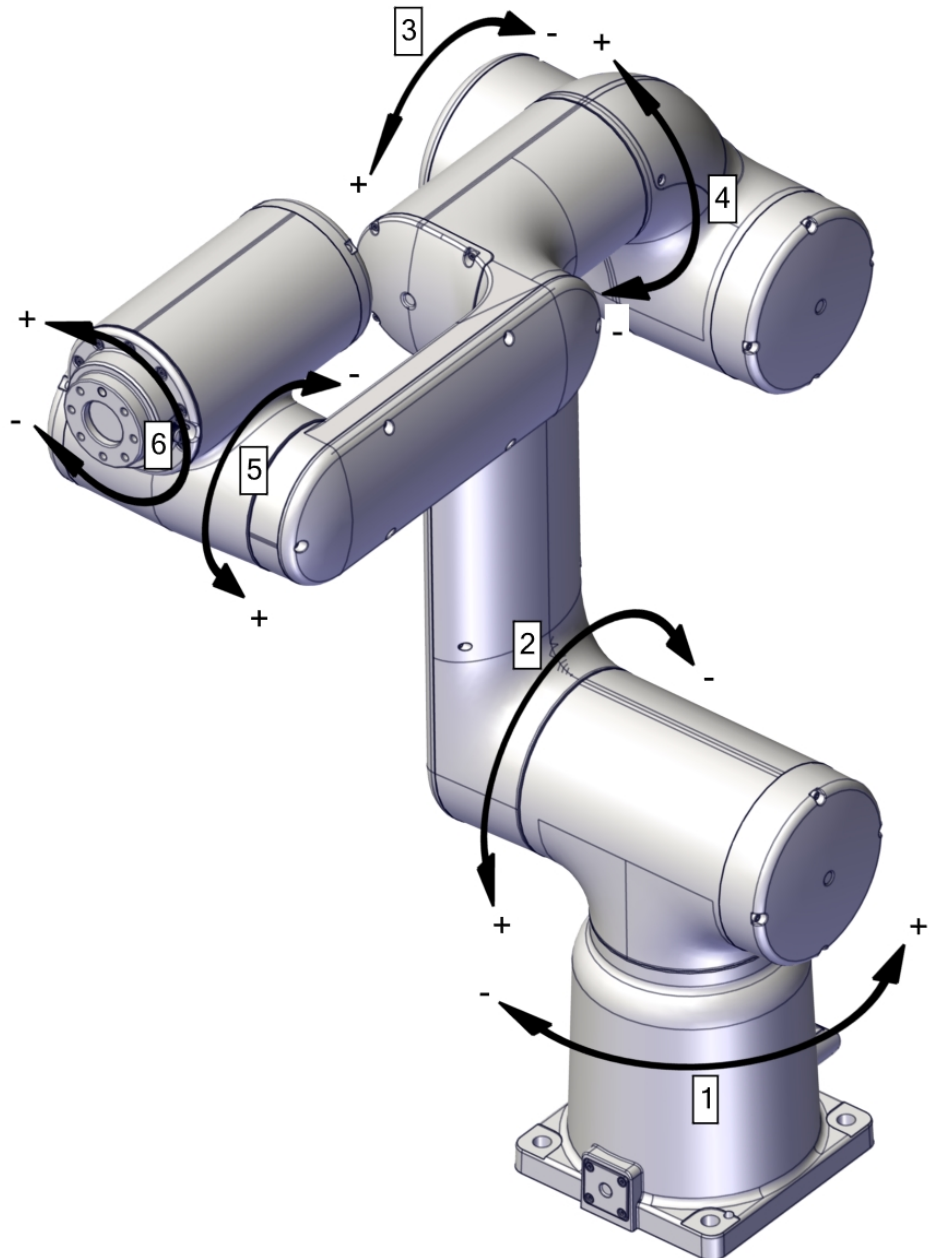

xx2000002400

6 Calibration

6.4 Calibrating with Wrist Optimization method

6.4 Calibrating with Wrist Optimization method

When to run Wrist Optimization

Wrist Optimization routine is run to improve TCP reorientation performance.

Calibrating the robot with standard calibration method overwrites the optimized positions of axes 4, 5. Re-run the Wrist Optimization routine after standard calibration to re-achieve the optimized positions of the wrist axes.

Overview of the calibration procedure on the FlexPendant

The actual instructions of how to perform the calibration procedure and what to do at each step is given on the FlexPendant. You will be guided through the calibration procedure, step by step.

Use the following list to learn about the calibration procedure before running the RobotWare program on the FlexPendant. It gives you a brief overview of the calibration procedure sequence.

After the calibration method has been called for on the FlexPendant, the following sequence will be run.

- 1 Choose calibration routine Wrist Optimization.
- 2 Modify targets for 4-point tool frame definition, in Wrist Optimization routine.



Tip

Select positions with large reorientations around the TCP. For best results, make sure that axis 4 and 5 have large movements.

- a Jog the robot to an appropriate position, A, for the first approach point.
Use small increments to accurately position the tool tip as close to the reference point as possible.
- b Tap **Modify Position** to define the point.
- c Repeat for each approach point to be defined, positions B, C, and D.
Jog away from the fixed world point to achieve the best result. Just changing the tool orientation will not give as good a result.

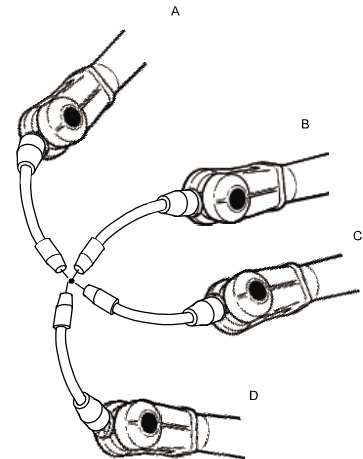

en0400000906

- 3 Improved calibration data to the wrist axes is identified and presented.
- 4 Optimized positions for the wrist axes are presented.
- 5 The controller must be restarted. Tap **Restart**.
- 6 After the controller is restarted, an event message appears, 50296 **Robot memory data difference**. Update the robot memory, as described in *Operating manual - Integrator's guide OmniCore*.

Continues on next page

- 7 Wrist optimization is finished.
- 8 Redefine / verify TCP for all tools.

This page is intentionally left blank

7 Troubleshooting

7.1 Introduction to troubleshooting

Introduction

The product manual and the circuit diagram contains information that can be good when troubleshooting.

For OmniCore, all event logs from the software can be seen on the FlexPendant, or in *Technical reference manual - Event logs for RobotWare 7*.

Make sure to read through the section [Safety on page 17](#) before starting.

Troubleshooting strategies

- 1 Isolate the fault to pinpoint the cause of the problem from consequential problems.
- 2 Divide the fault chain in two.
- 3 Check communication parameters and cables.
- 4 Check that the software version is compatible with the hardware.

Work systematically

- 1 Take a look around to make sure that all screws, connectors, and cables are secured, and that the robot and other parts are clean, not damaged, and correctly fitted.
- 2 Replace one thing at a time.
- 3 Do not replace units randomly.
- 4 Make sure that there are no loose screws, turnings, or other unexpected parts remaining after work has been performed.
- 5 When the work is completed, verify that the safety functions are working as intended.

Keep a track of history

- Make a historical fault log to keep track of problems over time.
- Consult those working with the robot when the problem occurred.

Basic scenarios

What to look for during troubleshooting depends on when the fault occurred. Was the robot recently installed or was it recently repaired? The following table gives hints on what to look for in specific situations.

The robot has recently been installed	Check: <ul style="list-style-type: none"> • the configuration files • connectors • options and their configuration • changes in the robot working space/movements.
---------------------------------------	--

Continues on next page

7 Troubleshooting

7.1 Introduction to troubleshooting

Continued

The robot has recently been repaired	Check: <ul style="list-style-type: none">• all connections to the replaced part• power supplies• that the correct part has been fitted• the last repair documents.
The robot recently had a software upgrade	Check: <ul style="list-style-type: none">• software versions• compatibilities between hardware and software• options and their configuration
The robot has recently been moved from one site to another (an already working robot)	Check: <ul style="list-style-type: none">• connections• software versions

7.2 Mechanical noise or dissonance

Description

Mechanical noise or dissonance that has not been observed before can indicate problems in bearings, motors, gearboxes, or similar. Be observant of changes over time.

A faulty bearing often emits scraping, grinding, or clicking noises shortly before failing.

Consequences

Failing bearings cause the path accuracy to become inconsistent, and in severe cases, the joint can seize completely.

Possible causes

The symptom can be caused by:

- Worn bearings.
- Contaminations have entered the bearing grooves.
- Loss of lubrication in bearings.
- Loose heat sinks, fans, or metal parts.

If the noise is emitted from a gearbox, the following can also apply:

- Overheating.

Recommended actions

The following actions are recommended:

	Action	Information
1	 CAUTION Allow hot parts to cool down.	
2	Verify that the service is done according to the maintenance schedule.	
3	If a bearing is emitting the noise, determine which one and make sure that it has sufficient lubrication.	
4	If possible, disassemble the joint and measure the clearance.	
5	Bearings inside motors are not to be replaced individually, but the complete motor is replaced.	
6	Make sure the bearings are fitted correctly.	
7	Tighten the screws if a heat sink, fan, or metal sheet is loose.	

7 Troubleshooting

7.3 Manipulator collapses on power down

7.3 Manipulator collapses on power down

Description

The manipulator is able to work correctly while Motors ON is active, but when Motors OFF is active, one or more axes drops or collapses under its own weight. The holding brakes (normally one in each motor), is not able to hold the weight of the manipulator arm.

Consequences

For a heavy robot, the collapse can cause severe injury to personnel working in the area or severe damage to the robot and/or surrounding equipment.
For a small robot, the collapse can cause injury to personnel working close to the robot or damage to the robot and/or surrounding equipment.

Possible causes

The symptom can be caused by:

- Faulty brake.
 - Faulty power supply to the brake.
-

Recommended actions

The following actions are recommended:

	Action	Information
1	Determine which motor(s) causes the robot to collapse.	
2	Check the brake power supply to the collapsing motor during the Motors OFF state.	See the circuit diagram. Check for any recorded fault status.

7.4 Brake release tool does not work

Description

The holding brake of a motor is not released using the brake release tool.

Consequences

The robot axis can not be manually moved.

Possible causes

The symptom can be caused by:

- The RobotWare version is 7.10 or higher. Then the brakes are released using the FlexPendant, see [Manually releasing the brakes on page 69](#).
- Damaged magnet on the brake release tool.
- Faulty power supply to the brake.
- Incorrect usage of the brake release tool:
 - There has been an attempt to use the brake release mechanism while the robot is in mode MOTORS ON.
 - There has been an attempt to use the brake release mechanism in automatic operating mode.
 - There has been an attempt to use the brake release mechanism during the startup phase of the controller, that is, before the controller is fully operational.
 - There has been an attempt to use the brake release mechanism while the manipulator is moving.
 - There has been a very brief application of the magnet to the brake release points, for example, by accident.
- Faulty joint electronic hardware.

Recommended actions

The following actions are recommended:

	Action	Information
1	Look for damage to the magnet. Replace the tool if damaged.	Brake release tool: 3HAC079146-001  Note The spare parts related to the brake release function using the external tool are discontinued from Q2 2023.
2	Verify that the brake release tool is used correctly.	See Manually releasing the brakes with the external tool on page 71 .
3	Check the brake power supply to the motor during the Motors OFF state.	See the circuit diagram. Check for any recorded fault status.

Continues on next page

7 Troubleshooting

7.4 Brake release tool does not work

Continued

	Action	Information
4	<p>Reset the brake release software as follows:</p> <ol style="list-style-type: none">1 Turn off electrical power supply to the robot.2 Turn on electrical power supply to the robot, without enabling the motors, and perform following step within 30 minutes.3 Wait for the controller to be fully operational, for example, verify that the FlexPendant is restarted. Place the brake release tool against the brake release point on the joint and hold for 2-10 seconds. Remove the brake release tool and wait for at least 2 seconds.4 Test the brake release function using the brake release tool against the brake release point on the joint.	<p>Software is reset. Any error code is removed from the FlexPendant.</p> <p>If the brake still does not release, repeat the reset cycle steps 3 and 4.</p> <p>Five (5) attempts are allowed in total to reset the brake release. If desired, the process can be repeated from step 1. If the brake still does not release, contact the local ABB customer service.</p>

7.5 Drive system communication link and DC link are both down during robot running

7.5 Drive system communication link and DC link are both down during robot running

Description

During robot running, the robot system enters system failure state with 34402 "DC link voltage too low" and 39351 "The drive system communication link is down" reported.

Consequence

No operation will be possible until the fault is corrected.

Possible causes

- The system power is derating when the robot system is running with incoming mains lower than 180 VAC.
 - The incoming mains voltage to the rectifier unit is out of specification.
 - Cable between manipulator and controller is disconnected.
-

Recommended actions

- 1 Run warm-up cycles.
- 2 Reduce acceleration or speed.
- 3 Change to 230 VAC incoming mains, or add an external transformer to upgrade the incoming mains to 230 VAC.
- 4 Check incoming mains voltage. Change the mains tolerance min so that the mains voltage is inside the specified interval.
- 5 Check the cable connection between manipulator and controller.
- 6 Check for other hardware event log messages regarding connection problem.

7 Troubleshooting

7.6 Communication failure between PROFI-safe-based laser scanner, PLC, and controller

7.6 Communication failure between PROFI-safe-based laser scanner, PLC, and controller

Description

The ProfiNet LED on the laser scanner is not lit up, indicating that the profinet communication between the laser scanner, PLC, and OmniCore controller fails to be set up. However, the cable connection is properly connected and necessary parameters are correctly set during the laser scanner configuration.

This issue may occur when PROFI-safe-based laser scanner(s) is connected.

Consequences

Communication fails to be set up between the laser scanner, PLC, and OmniCore. The safety separation function with the laser scanner cannot be applied.

Possible causes

The firewall for the ProfiNet network is disabled.

Recommended actions

- 1 Open RobotStudio.
- 2 In the **Controller** tab page, choose **Communication** from the **Configuration** group.
- 3 Select **Firewall Manager** in the **Type** pane.
- 4 Set **Enable on Public Network** to **Yes** for the network service **ProfiNet**.

7.7 Communication failure between PLC and controller

Description

The OmniCore controller and PLC are configured with all parameters correctly set. However, the communication between the OmniCore controller and PLC still fails. This issue may occur when the PROFIsafe-based laser scanner(s) is connected.

Consequence

The safety configurations do not take effect.

Possible causes

During configuration of communication between the OmniCore controller and PLC, the PROFIsafe device information must be configured on the OmniCore controller's side first. Otherwise, the configured signals will not be saved in the safety module in the OmniCore controller.

Recommended actions

- 1 Open the RobotStudio.
- 2 In the **Controller** tab page, choose **Visual SafeMove** from **Safety** in the **Configuration** group.
- 3 Check the Safe I/O configurations.

For robots running RobotWare 7.5 or earlier, the following signals can be observed.

Signal name	Default value	Offset	Width	Signals uses
ProtectingArea	0	0	1	Writer: SDI_8_bytes
WarningArea	0	1	1	Writer: SDI_8_bytes
ProtectingAreaSST	0	2	1	Writer: SDI_8_bytes
WarningAreaTSP	0	3	1	Writer: SDI_8_bytes
SafetyCommunicationEnable	0	4	1	Writer: SDI_8_bytes

xx2100000511

Continues on next page

7 Troubleshooting

7.7 Communication failure between PLC and controller

Continued

For robots running RobotWare 7.6 or later, the following signals can be observed.

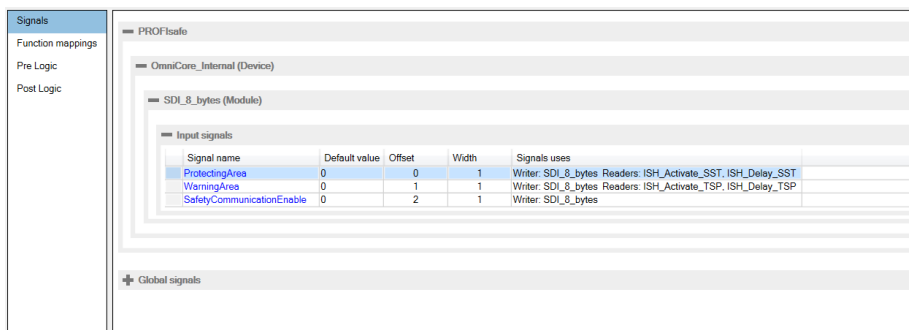

The screenshot shows a configuration window for PROFIsafe. On the left, there is a sidebar with 'Signals' selected, and sub-items for 'Function mappings', 'Pre Logic', and 'Post Logic'. The main area displays a tree view of the configuration: PROFIsafe > OmniCore_Internal (Device) > SDI_8_bytes (Module) > Input signals. Below this, a table lists the input signals with their properties and usage.

Signal name	Default value	Offset	Width	Signals uses
ProtectingArea	0	0	1	Writer: SDI_8_bytes Readers: ISH_Activate_SST, ISH_Delay_SST
WarningArea	0	1	1	Writer: SDI_8_bytes Readers: ISH_Activate_TSP, ISH_Delay_TSP
SafetyCommunicationEnable	0	2	1	Writer: SDI_8_bytes

xx2200000304

- 4 If the signals cannot be observed, choose **I/O Engineering Tool** from **Configuration** in the **Configuration** group.
- 5 Go back to the **Visual SafeMove** window and write the **SafeMove** configurations to the controller again.
You will observe the signals and the communication is correctly set up.

7.8 Communication failure between scalable I/O device and controller

Description

The OmniCore controller and scalable I/O device DSQC1042 are configured with all parameters correctly set. However, the communication between the OmniCore controller and scalable I/O device still fails.

This issue may occur when the SafetyIO-based laser scanner(s) is connected.

Consequence

The safety configurations do not take effect.

Possible causes

During configuration of communication between the OmniCore controller and scalable I/O device, the scalable I/O device information must be configured on the OmniCore controller's side first. Otherwise, the configured signals will not be saved in the OmniCore controller.

Recommended actions

- 1 Open the RobotStudio.
- 2 In the **Controller** tab page, choose **Visual SafeMove** from **Safety** in the **Configuration** group.
- 3 Check the Safe I/O configurations.

The following signals can be observed.

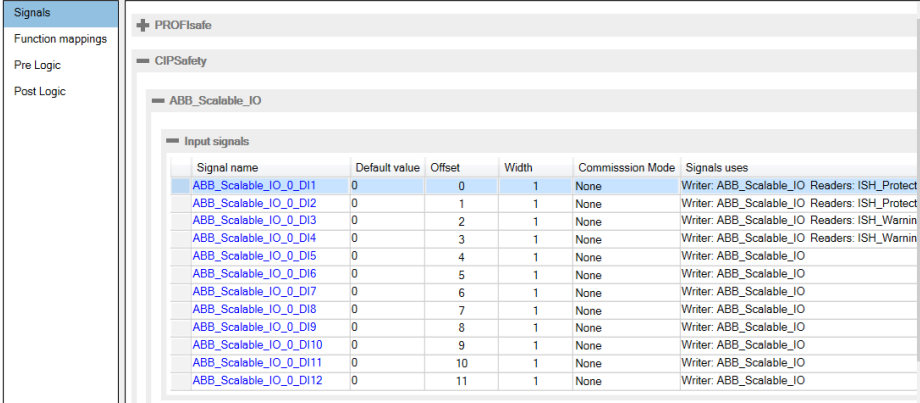

Signal name	Default value	Offset	Width	Commission Mode	Signals uses
ABB_Scalable_IO_0_DI1	0	0	1	None	Writer: ABB_Scalable_IO Readers: ISH_Protect
ABB_Scalable_IO_0_DI2	0	1	1	None	Writer: ABB_Scalable_IO Readers: ISH_Protect
ABB_Scalable_IO_0_DI3	0	2	1	None	Writer: ABB_Scalable_IO Readers: ISH_Warmin
ABB_Scalable_IO_0_DI4	0	3	1	None	Writer: ABB_Scalable_IO Readers: ISH_Warmin
ABB_Scalable_IO_0_DI5	0	4	1	None	Writer: ABB_Scalable_IO
ABB_Scalable_IO_0_DI6	0	5	1	None	Writer: ABB_Scalable_IO
ABB_Scalable_IO_0_DI7	0	6	1	None	Writer: ABB_Scalable_IO
ABB_Scalable_IO_0_DI8	0	7	1	None	Writer: ABB_Scalable_IO
ABB_Scalable_IO_0_DI9	0	8	1	None	Writer: ABB_Scalable_IO
ABB_Scalable_IO_0_DI10	0	9	1	None	Writer: ABB_Scalable_IO
ABB_Scalable_IO_0_DI11	0	10	1	None	Writer: ABB_Scalable_IO
ABB_Scalable_IO_0_DI12	0	11	1	None	Writer: ABB_Scalable_IO

xx2200000305

- 4 If the signals cannot be observed, choose **I/O Engineering Tool** from **Configuration** in the **Configuration** group.
- 5 Go back to the **Visual SafeMove** window and write the SafeMove configurations to the controller again.

You will observe the signals and the communication is correctly set up.

7 Troubleshooting

7.9 System failure when changing PROFINET-based laser scanner to SafetyIO-based laser scanner

7.9 System failure when changing PROFINET-based laser scanner to SafetyIO-based laser scanner

Description

The robot configured with PROFINET-based laser scanner(s) needs to replace with SafetyIO-based laser scanner. During system update using the **Installation Manager**, system failure occurs after removing the profisafe package option(s) and selecting required IO package option(s).

Consequence

The system cannot be successfully set up.

Possible causes

Option *3020-2 PROFINET Device* and option *3023-2 PROFIsafe Device* are removed together with the profisafe package option(s), and the safety configurations become invalid.

Recommended actions

- 1 On the home page of the FlexPendant, tap **Settings**.
- 2 Tap **Backup & Recovery**.
- 3 Tap **Reset user data**.
- 4 Select **Reset safety settings**.
- 5 Tap **Reset**.
- 6 Restart the controller.

If the problem persists, reinstall the system.

7.10 Movement in Safe area not in full speed or at zero speed

Description

The speed in the Safe area is not at the full speed specified in the motion instruction or even at zero speed after the SST/TSP violation is triggered.

This issue may occur when robot is running in RobotWare 7.5 or an earlier version.

Consequences

Robot cannot move in the specified speed, that is, in slow speed, or even stops movement in the Safe area.

Possible causes

Before the SST/TSP is triggered, the system triggers Protecting or Warning area speed control first. In this case, the speed control module uses the value of `SpeedRefresh` to control the robot movement speed. At the time that the SST/TSP triggers the robot stopping, the speed control has already changed by the `SpeedRefresh` value which is 0 in Protecting area and 20 in Warning area.

When users are back to the Safe area and restart or step the program after the SST/TSP violation, the `SpeedRefresh` value that refresh the speed to 100 does not take effect. That is, the speed is still controlled by the `SpeedRefresh` value 0 or 20. Although the speed shown in the FlexPendant is 100%, the actual speed is still controlled by the combination of the `SpeedRefresh` value and the speed set in motion instruction, which will result in the movement stopping or moving in slow speed in the Safe area.

Furthermore, when the STT violation is triggered, the manipulator triggers Cat0 or Cat1 emergency stop. If the user tries to start program in the Protecting area but is not in the STT area, the robot will start moving a short path to regain the previous point and then stop. In this case, the speed is restricted to 0.

For more details, see [Strategies \(RobotWare 7.5\) on page 174](#).

Recommended actions

Users could perform either of the following solutions:

- Reset the program pointer and start the program in the Safe area again.
- Enter the Warning area but not trigger the TSP supervision violation and then back to the Safe area again.

7 Troubleshooting

7.11 Unable to remove or reselect installed options in Collaborative Speed Control add-in

7.11 Unable to remove or reselect installed options in Collaborative Speed Control add-in

Description

The installed lead-through or laser scanner options fail to be removed or reselected in the Collaborative Speed Control add-in using Installation Manager 7.

Consequence

- Modules of the SpeedHandling function remain in task T_ROB1 after the installed options are removed.
- Existing template SafeMove configuration file is not removed after the installed options are removed or not synchronized with new configuration file for the new option after the installed options are reselected.

Recommended actions

- 1 Reset the template SafeMove configuration file to factory settings and apply it to the controller.
- 2 For scenarios to remove options, de-select the checkboxes of the options that require to be removed in the Collaborative Speed Control add-in and apply it to the controller.
- 3 For scenarios to reselect options, de-select the checkboxes of the options not required first and then select the required options in the Collaborative Speed Control add-in and apply it to the controller.
- 4 Reset the RAPID programs and parameters in RobotStudio and restart the controller.
- 5 Load the template SafeMove configuration file using the SafeMove configurator app on FlexPendant.

7.12 Unexpected robot movement when starting the program in Protecting Area

Description

The robot moves unexpectedly in a speed not larger than 250 mm/sec when the user starts the program in Protecting area, in which situation the robot should be stopped and stand still.

Consequence

The unexpected robot movement may cause damages or injuries to objects or persons within its movement range.

Possible causes

The robot moves in mentioned scenario only when all of the following conditions are met:

- The function `ISH_b_FunctionalityIsUsed` in RAPID program `InternalSpeedHandling_User` is set to `TRUE`.
- The template `SafeMove` configuration file provided with the Collaborative Speed Control add-in is not loaded, or is loaded but `Global_SST` configuration is removed or the `ISH_UserMODE_bNot_IntemitCollab` is set to 1.
- The system is in Auto mode or Manual Full Speed mode.
- The robot was stopped during running a program, and then manually moved to another position which is within the range of the robot return path.
- The user stands in Protecting area and restarts the program using FlexPendant.

Recommended actions

Reset the template `SafeMove` configuration file to factory setting and then load the configuration file provided with the Collaborative Speed Control add-in. See detailed procedures in [The SafeMove configurator app on FlexPendant on page 120](#).

7 Troubleshooting

7.13 Diagnostic LEDs on joint unit drive board

7.13 Diagnostic LEDs on joint unit drive board

Location of LEDs on the drive board

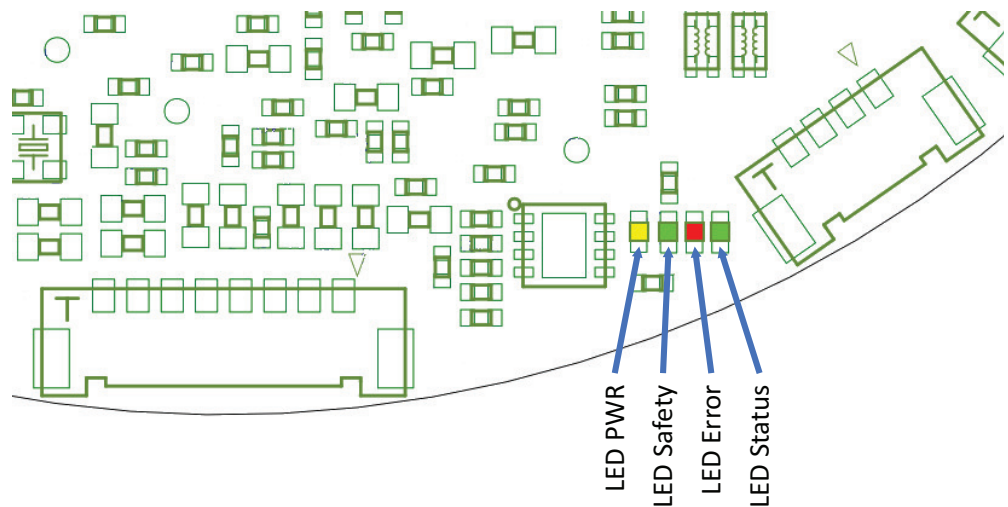
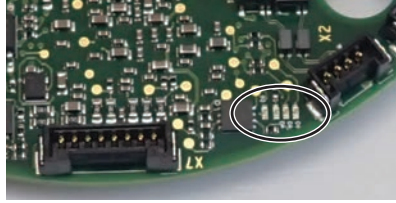

xx220000706

LED PWR	LED Power
LED Safety	Safety LED (green)
LED Error	Functional error LED (red)
LED Status	Functional status LED (green)

Diagnostic codes

LED PWR

Diagnostic code	Description
Remain ON	Power is on

LED Safety (green): Safety LED

Diagnostic code	Description
Blinking fast (less than 1s blinking)	FSoE ⁱ connection is active
Blinking slow (2s on, 4s off)	No FSoE ⁱ connection
Not blinking within 10s from reboot and stopped	Safety software is in fatal state

ⁱ Safety over EtherCAT

Continues on next page

LED Error (red): Functional LED

Diagnostic code	Description
Flash 4 times then pause	EtherCAT cable is not connected
	Problem in communication
Flash 1 time then pause	Drive status word ⁱ fault

ⁱ DS402

LED Status (green): Functional LED

Diagnostic code	Description
Remain ON	Drive status word ⁱ : Internal limitation is active
Flash 3 times then pause	Drive status word ⁱ : Operation is enabled
Flash 2 times then pause	Drive status word ⁱ : Ready to switch on / Motor on
Flash 1 time then pause	Other state than what mentioned above

ⁱ DS402

This page is intentionally left blank

8 Decommissioning

8.1 Introduction to decommissioning

Introduction

This section contains information to consider when taking a product, robot or controller, out of operation.

It deals with how to handle potentially dangerous components and potentially hazardous materials.



Note

The decommissioning process shall be preceded by a risk assessment.

Disposal of materials used in the robot

All used grease/oils and dead batteries **must** be disposed of in accordance with the current legislation of the country in which the robot and the control unit are installed.

If the robot or the control unit is partially or completely disposed of, the various parts **must** be grouped together according to their nature (which is all iron together and all plastic together), and disposed of accordingly. These parts **must** also be disposed of in accordance with the current legislation of the country in which the robot and control unit are installed.

See also [Environmental information on page 1090](#).

Transportation

Prepare the robot or parts before transport, this to avoid hazards.

8 Decommissioning

8.2 Environmental information

8.2 Environmental information

Introduction

ABB robots contain components in different materials. During decommissioning, all materials should be dismantled, recycled, or reused responsibly, according to the relevant laws and industrial standards. Robots or parts that can be reused or upcycled helps to reduce the usage of natural resources.

Symbol

The following symbol indicates that the product must not be disposed of as common garbage. Handle each product according to local regulations for the respective content (see table below).



xx1800000058

Materials used in the product

The table specifies some of the materials in the product and their respective use throughout the product.

Dispose components properly according to local regulations to prevent health or environmental hazards.

Material	Example application
Aluminium	Base, lower arm, upper arm
Copper	Cables, motors, brakes
Electronics	PCBAs, sensors, brake release unit
Neodymium	Motors, brake release tool
Nickel	Tool flange, protection cap
Oil, grease	Gearboxes
Plastic/rubber	Cables, connectors, holder, covers, and so on
Steel	Gears, screws, sheet metals, brackets

Continues on next page

China RoHS symbol

The following symbol shows the information to hazardous substances and the environmental protection use period of CRB 15000 according to "Management Methods for the Restriction of the Use of Hazardous Substances in Electrical and Electronic Products (SJ/T 11364-2014)".



xx190000803

Green symbol with "e" in it: The product does not contain any hazardous substances exceeding concentration limits and is a green environmentally friendly product which can be recycled.

Oil and grease

Where possible, arrange for oil and grease to be recycled. Dispose of via an authorized person/contractor in accordance with local regulations. Do not dispose of oil and grease near lakes, ponds, ditches, down drains, or onto soil. Incineration must be carried out under controlled conditions in accordance with local regulations.

Also note that:

- Spills can form a film on water surfaces causing damage to organisms. Oxygen transfer could also be impaired.
- Spillage can penetrate the soil causing ground water contamination.

8 Decommissioning

8.3 Scrapping of robot

8.3 Scrapping of robot



Note

The decommissioning process shall be preceded by a risk assessment.

Important when scrapping the robot



DANGER

The risk assessment should consider hazards arising in the decommissioning, such as, but not limited to:

- Always remove all oil/grease in gearboxes. If exposed to heat, for example from a blow torch, the oil/grease will catch fire.
- When motors are removed from the robot, the robot will collapse if it is not properly supported before the motor is removed.
- A used robot does not have the same performance as on delivery. Springs, brakes, bearings, and other parts might be worn or broken.

9 Reference information

9.1 Introduction

General

This chapter includes general information, complementing the more specific information in the different procedures in the manual.

9 Reference information

9.2 Applicable standards

9.2 Applicable standards

General

The product is compliant with ISO 10218-1:2011, *Robots for industrial environments - Safety requirements - Part 1 Robots*, and applicable parts in the normative references, as referred to from ISO 10218-1:2011. In case of deviation from ISO 10218-1:2011, these are listed in the declaration of incorporation. The declaration of incorporation is part of the delivery.

Robot standards

Standard	Description
ISO 9283	Manipulating industrial robots – Performance criteria and related test methods
ISO 9787	Robots and robotic devices – Coordinate systems and motion nomenclatures
ISO 9946	Manipulating industrial robots – Presentation of characteristics

Other standards used in design

Standard	Description
IEC 60204-1	Safety of machinery - Electrical equipment of machines - Part 1: General requirements, normative reference from ISO 10218-1
IEC 61000-6-2	Electromagnetic compatibility (EMC) – Part 6-2: Generic standards – Immunity standard for industrial environments
IEC 61000-6-4	Electromagnetic compatibility (EMC) – Part 6-4: Generic standards – Emission standard for industrial environments
ISO 13849-1:2006	Safety of machinery - Safety related parts of control systems - Part 1: General principles for design, normative reference from ISO 10218-1
ISO/TS 15066	Robots and robotic devices - Collaborative robots This Technical Specification specifies safety requirements for collaborative industrial robot systems and the work environment, and supplements the requirements and guidance on collaborative industrial robot operation given in ISO 10218-1 and ISO 10218-2.

Region specific standards and regulations

Standard	Description
ANSI/RIA R15.06	Safety requirements for industrial robots and robot systems
ANSI/UL 1740	Safety standard for robots and robotic equipment
CAN/CSA Z 434-03	Industrial robots and robot Systems - General safety requirements
EN ISO 10218-1	Robots and robotic devices — Safety requirements for industrial robots — Part 1: Robots

Continues on next page

Deviations

Deviations from ISO 10218-1:2011 for CRB 15000

The CRB 15000 is intended for collaborative operation. The integrator of the robot system is required to perform an assessment of the hazards and risks.

Requirement	Deviation for CRB 15000	Motivation
§5.3.5 Single point of control.	The arm side interface can be overridden in automatic mode.	The CRB 15000 robot is intended for collaborative applications where contact between robot and the operator is harmless.

Deviations from IEC 60204-1 for CRB 15000

Requirement	Deviation for CRB 15000	Motivation
§12.5 Conductor and cable voltage drop	The voltage drop of customer power (CP) on customer flange interface (CFI) may exceed 5% when using a 15 m-length hybrid floor cable.	CFI can be used when using the 15 m-length hybrid floor cable. The voltage drop of CP can be compensated by increasing input voltage (max. 30V).

9 Reference information

9.3 Unit conversion

9.3 Unit conversion

Converter table

Use the following table to convert units used in this manual.

Quantity	Units		
Length	1 m	3.28 ft.	39.37 in
Weight	1 kg	2.21 lb.	
Weight	1 g	0.035 ounces	
Pressure	1 bar	100 kPa	14.5 psi
Force	1 N	0.225 lbf	
Moment	1 Nm	0.738 lbf-ft	
Volume	1 L	0.264 US gal	

9.4 Screw joints

General

This section describes how to tighten the various types of screw joints on ABB robots.

The instructions and torque values are valid for screw joints comprised of metallic materials and do *not* apply to soft or brittle materials.

Gleitmo treated screws

Gleitmo is a special surface treatment to reduce the friction when tightening the screw joint. It is recommended by ABB for M6-M20 screw joints. Screws treated with Gleitmo may be reused 3-4 times before the coating disappears. After this the screw must be discarded and replaced with a new one.

When handling screws treated with Gleitmo, protective gloves of nitrile rubber type should be used.

Generally, screws are lubricated with *Gleitmo 603* mixed with *Geomet 500* or *Geomet 702* in proportion 1:3. *Geomet* thickness varies according to screw dimensions, refer to the following.

Dimension	Lubricant	Geomet thickness
M6-M20 (any length except M20x60)	<i>Gleitmo 603</i> + <i>Geomet 500</i>	3-5 µm
M6-M20 (any length except M20x60)	<i>Gleitmo 603</i> + <i>Geomet 720</i>	3-5 µm
M20x60	<i>Gleitmo 603</i> + <i>Geomet 500</i>	8-12 µm
M20x60	<i>Gleitmo 603</i> + <i>Geomet 720</i>	6-10 µm

Tightening torque

Before tightening any screw, note the following:

- **Special torques** are specified in the repair, maintenance or installation procedure descriptions. **Any special torque specified overrides a standard torque!**
- Use the *correct tightening torque* for each type of screw joint.
- Only use *correctly calibrated* torque keys.
- *Always tighten the joint by hand*, and never use pneumatic tools.
- Use the *correct tightening technique*, that is *do not* jerk. Tighten the screw in a slow, flowing motion.
- Maximum allowed total deviation from the specified value is **10%**!

9 Reference information

9.5 Weight specifications

9.5 Weight specifications

Definition

In installation, repair, and maintenance procedures, weights of the components handled are sometimes specified. All components exceeding 22 kg (50 lbs) are highlighted in this way.

To avoid injury, ABB recommends the use of a lifting accessory when handling components with a weight exceeding 22 kg. A wide range of lifting accessories and devices are available for each manipulator model.

Example

Following is an example of a weight specification in a procedure:

	Action	Note
	 CAUTION The arm weighs 25 kg. All lifting accessories used must be sized accordingly.	

9.6 Standard toolkit

General

All service (repairs, maintenance, and installation) procedures contains lists of tools required to perform the specified activity.

All special tools required are listed directly in the procedures while all the tools that are considered standard are gathered in the standard toolkit and defined in the following table.

This way, the tools required are the sum of the standard toolkit and any tools listed in the instruction.

Contents, standard toolkit

Qty	Tool	Note
1	Torque wrench, 0.2-4.6 Nm	
1	Hexagon bit socket head cap, size 1.5 mm	
1	Hexagon bit socket head cap, size 2 mm	
1	Hexagon bit socket head cap, size 2.5 mm	
1	Hexagon bit socket head cap, size 3 mm	
1	Tweezer	
1	Cable ties	

9 Reference information

9.7 Special tools

9.7 Special tools

General

All service instructions contain lists of tools required to perform the specified activity. The required tools are a sum of standard tools, defined in the section [Standard toolkit on page 1099](#), and of special tools, listed directly in the instructions and also gathered in this section.







Special tools

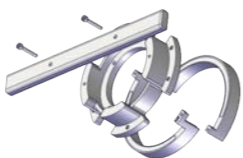

Note

If the replacing procedure is not listed in the table below, only standard tools are needed for the procedure.



Continues on next page

Tools and equipment with spare part number: (These tools can be ordered from ABB)			Axis-1 cabling	Axis-2 cabling	Axis-3 cabling	Axis-4 cabling	Axis-5 cabling	Axis-6 cabling	Axis-5 to axis-6 transition cabling	Lower arm	Housing	Tubular	Wrist housing	Base	Swing	Axis-1 joint unit	Axis-2 joint unit	Axis-3 joint unit	Axis-4 joint unit	Axis-5 joint unit	Axis-6 joint unit	
Lifting accessories																						
Lifting aid	3HAC077788-001	 xx210000465	1								1			1	1	1	1	1				
Lifting aid	3HAC077789-001	 xx210000464						1				1	1						1	1	1	
Lifting aid	3HAC087787-001	 xx230000825	1											1	1	1	1					
Lifting aid	3HAC087788-001	 xx230000826									1							1				
Guiding tools																						
Guide pin, M4x120	3HAC077786-001	 xx210000463	2							2	2			2	2	2	2	2				
Guide pin, M3x110	3HAC077787-001	 xx210000462						2		2	2	2							2	2	2	

Continues on next page

9 Reference information

9.7 Special tools

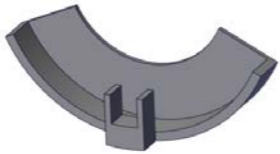
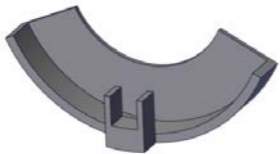
Tools and equipment with spare part number: (These tools can be ordered from ABB)			Axis-1 cabling	Axis-2 cabling	Axis-3 cabling	Axis-4 cabling	Axis-5 cabling	Axis-6 cabling	Axis-5 to axis-6 transition cabling	Lower arm	Housing	Tubular	Wrist housing	Base	Swing	Axis-1 joint unit	Axis-2 joint unit	Axis-3 joint unit	Axis-4 joint unit	Axis-5 joint unit	Axis-6 joint unit	
Guide pin, M5x125	3HAC087786-001	 xx2300000824	2	2						2				2	2	2	2					
Guide pin, M5x75	3HAC087786-002	 xx2300000824	2											2	2	2						
Other tools																						
Cable tie gun EVO 7i	-		1	1	1	1	1	1	1				1	1	1	1	1	1	1	1	1	1
Protection plate	3HAC077790-001	 xx2100000461	1	1	1	1	1	1	1				1	1	1	1	1	1	1	1	1	1
Protection plate	3HAC087789-001	 xx2100000461	1	1	1	1	1	1	1				1	1	1	1	1	1	1	1	1	1

Continues on next page

Index

A

Absolute Accuracy, calibration, 1064
 allergenic material, 29
 aluminum
 disposal, 1090
 ambient humidity
 operation, 43
 storage, 43
 ambient temperature
 operation, 43
 storage, 43
 arm side interface
 replacing, 645
 arm-side interface
 configuring buttons, 107
 configuring light ring, 108
 default configuration, 106
 description, 105
 using the buttons, 109
 ASI, 105
 ASI Setting, 105
 assembly instructions, 55
 assessment of hazards and risks, 17, 29
 axis-6 inner flange
 replacing, 638
 axis-6 joint unit
 replacing, 1039
 axis-5 joint unit
 replacing, 992
 axis-4 joint unit
 replacing, 954
 axis-3 joint unit
 replacing, 917
 axis-2 joint unit
 replacing, 860, 888
 axis-1
 joint unit, 776, 816
 Axis Calibration
 procedure on FlexPendant, 1068

B

base
 replacing, 649
 base cabling
 replacing, 205
 Brake power supply, faulty, 1074–1075
 brake release tool, 75
 brake release tool faulty, 1075
 brake release unit
 replacing, 491
 brake releasing, 69, 71
 brakes
 testing function, 35

C

cabinet lock, 29
 cable harness
 inspecting, 190
 cabling, base, 205
 cabling, joint-6, 466
 cabling, joint-5, 420
 cabling, joint-4, 382
 cabling, joint-3, 347
 cabling, joint-2, 293

cabling, joint-1, 221
 cabling, transition axis-5 to axis-6, 490, 992
 cabling between robot and controller, 99
 calibrating robot, 1068
 calibrating the torque sensors, 1065
 calibration
 Absolute Accuracy type, 1063
 calibration, Absolute Accuracy, 1064
 calibration manuals, 1064
 CalibWare, 1063
 carbon dioxide extinguisher, 29
 cleaning, 195
 connecting the robot and controller, cabling, 99
 constrained collisions, 111
 copper
 disposal, 1090

D

damaged bearings, 1073
 dimensions
 robot, 81
 directions of axes, 1067
 Dual PROFI-safe-based laser scanner
 laser scanner, 93–94, 152, 160
 Dual SafetyIO-based laser scanner
 laser scanner, 95, 169

E

electronics
 disposal, 1090
 EN ISO 13849-1, 45
 environmental information, 1090
 equipment, robot, 81
 ESD
 damage elimination, 53
 sensitive equipment, 53
 extra equipment, 81

F

factory settings for SafeMove, 121
 faulty brake, 1074
 faulty brake release tool, 1075
 fire extinguishing, 29
 fitting, equipment, 81
 FlexPendant application, 120
 floor plan, 130
 foundation
 requirements, 42
 frame
 replacing, 724

G

Global Settings
 FlexPendant application, 120
 Gravity Alpha, 78
 Gravity Beta, 77
 grease, 33
 disposal, 1090

H

hanging
 installed hanging, 29
 hazard levels, 20
 hazardous material, 1090
 height
 installed at a height, 29
 hot gearbox oil, 1073

hot surfaces, 31, 33

housing

replacing, 528

HRA, 17, 29

humidity

operation, 43

storage, 43

I

inspecting

cable harness, 190

robot, 186

installation

equipment, 81

laser scanner, 91

installation procedure, 60

instructions for assembly, 55

integrator responsibility, 29

intended use, 17

intervals for maintenance, 185

J

jogging directions, 1067

joint-6 cabling

replacing, 466

joint-5 cabling

replacing, 420

joint-4 cabling

replacing, 382

joint-3 cabling

replacing, 347

joint-2 cabling

replacing, 293

joint-1 cabling

replacing, 221

L

labels

robot, 22

laser scanner

installation, 91

Laser scanner

dual PROFIsafe-based laser scanner, 93–94

RobotWare 7.6 or later, 152, 160

Dual SafetyIO-based laser scanner, 95, 169

PROFINET-based laser scanner, 142

PROFIsafe-based laser scanner, 92–93

RobotWare 7.10 or later, 156

RobotWare 7.6 or later, 148

SafetyIO-based laser scanner, 94, 164

lead-through, 117

lifting

robot, 61

lifting accessory, 1098

limitation of liability, 17

load, 118

loads on foundation, 40

local client, 114

local presence, 114

lock and tag, 29

locked configuration file, 131

lower arm

replacing, 509

lubricants, 33

M

magnesium

disposal, 1090

maintenance intervals, 185

maintenance schedule, 185

mounting, equipment, 81

MTTF_D, 45

N

national regulations, 29

neodymium

disposal, 1090

noise, 1073

O

oil, 33

disposal, 1090

operating conditions, 43

original spare parts, 18

P

payload, 118

pedestal

installed on pedestal, 29

performance level, PL, 45

personnel

requirements, 19

PFH_D, 45–46

PL, performance level, 45

plastic

disposal, 1090

PPE, 19

product standards, 1094

PROFINET-based laser scanner

laser scanner, 142

PROFIsafe-based laser scanner

laser scanner, 92–93, 148, 156

protection classes, 43

protection type, 43

protective equipment, 19

protective wear, 19

Q

quasi-static contact

definition, 132

R

recycling, 1090

regional regulations, 29

release brakes, 34

replacements, report, 201

replacing

arm side interface, 645

axis-6 inner flange, 638

axis-6 joint unit, 1039

axis-5 joint unit, 992

axis-4 joint unit, 954

axis-3 joint unit, 917

axis-2 joint unit, 860, 888

axis-1 joint unit, 776, 816

base, 649

base cabling, 205

brake release unit, 491

frame, 724

housing, 528

joint-6 cabling, 466

joint-5 cabling, 420

joint-4 cabling, 382

joint-3 cabling, 347

- joint-2 cabling, 293
- joint-1 cabling, 221
- lower arm, 509
- swing, 724
- tool flange, 638
- transition cabling, 490, 992
- tubular, 565
- wrist, 599
- report replacements, 201
- required performance level, PLr, 45
- requirements on foundation, 42
- responsibility and validity, 17
- risk of burns, 31, 33
- robot
 - dimensions, 81
 - equipment, fitting, 81
 - inspecting, 186
 - labels, 22
 - lifting, 61
 - protection class, 43
 - protection types, 43
 - symbols, 22
 - technical data, 40
 - working range, 47
- Robot Encapsulation**
 - FlexPendant application, 120
- rubber
 - disposal, 1090
- S**
- SafeMove application, 120
- safety
 - brake testing, 35
 - ESD, 53
 - fire extinguishing, 29
 - release robot axes, 34
 - signals, 20
 - signals in manual, 20
 - symbols, 20
 - symbols on robot, 22
 - test run, 90
- safety configuration report, 130
- Safety configurations
 - lamp indicator, 177
 - speed control, 177
 - template SafeMove configuration file, 177
- safety devices, 30
- SafetyIO-based laser scanner
 - laser scanner, 94, 164
- safety signals
 - in manual, 20
- safety standards, 1094
- Safe Zones**
 - FlexPendant application, 120
- schedule of maintenance, 185
- screw joints, 1097
- securing the robot to foundation, attachment screws, 61
- shipping, 1089
- signals
 - safety, 20
- single point of control, 114
- singularities, 115
- Speed control
 - safety configurations, 177–178
 - strategies, 174
- standards, 1094
 - ANSI, 1094
 - CAN, 1094
- steel
 - disposal, 1090
- storage conditions, 43
- suspended mounting, 77
- swing
 - replacing, 724
- symbols
 - safety, 20
- Synchronization**
 - FlexPendant application, 120
- system integrator requirements, 29
- system parameter
 - Gravity Alpha, 78
 - Gravity Beta, 77
- T**
- technical data
 - robot, 40
- temperatures
 - operation, 43
 - storage, 43
- template configurations for SafeMove, 121
- Template SafeMove configuration file
 - safety configurations, 177–178, 180
- testing
 - brakes, 35
- Tool Data**
 - FlexPendant application, 120
- Tool Encapsulation**
 - FlexPendant application, 120
- tool flange
 - replacing, 638
- TorqueSensorCal, 1065
- torques on foundation, 40
- transient contact
 - definition, 132
- transition cabling
 - replacing, 490, 992
- transportation, 1089
- troubleshooting
 - safety, 36
- tubular
 - replacing, 565
- turning radius, 50
- U**
- unconstrained collisions, 111
- upcycling, 1090
- users
 - requirements, 19
- V**
- validated configuration file, 130
- validity and responsibility, 17
- W**
- wall mounting, 77
- weight, 40
 - robot, 65–66, 207–208, 217–218, 494, 501
 - upper and lower arm, 227, 242, 246, 266, 286, 298, 310, 313, 328, 342, 655, 670, 674, 696, 712, 717, 730, 741, 745, 758, 764, 771, 781, 808, 821, 825, 848, 853, 865, 883, 893, 897, 912
 - upper arm, complete, 353, 515, 534, 923
 - working range, 52
 - robot, 47

wrist
replacing, 599

Wrist Optimization
overview of method, 1068



ABB AB

Robotics & Discrete Automation

S-721 68 VÄSTERÅS, Sweden

Telephone +46 10-732 50 00

ABB AS

Robotics & Discrete Automation

Nordlysvegen 7, N-4340 BRYNE, Norway

Box 265, N-4349 BRYNE, Norway

Telephone: +47 22 87 2000

ABB Engineering (Shanghai) Ltd.

Robotics & Discrete Automation

No. 4528 Kangxin Highway

PuDong New District

SHANGHAI 201319, China

Telephone: +86 21 6105 6666

ABB Inc.

Robotics & Discrete Automation

1250 Brown Road

Auburn Hills, MI 48326

USA

Telephone: +1 248 391 9000

abb.com/robotics