



Z-Arm 1832

Product Manual

Industrial Robot / Collaborative Robot / Electric Gripper/
Intelligent Actuator / Automation Solution



Z-Arm 1832/Z-Arm XX32



High precision

Repeatability
±0.02mm

Z-axis customization

0.1-0.5m

Large arm span

J1 axis 160mm
J2 axis 160mm

Competitive price

Industrial-level quality
Consumptive price

Model Definition

Z-Arm T1832C0-FXXX-01

T	18	32	C	0	FXXX-01
Blank: Four axis F: Five axis T: Three axis S: Six axis	If z-axis stroke is 180, here is 18	If robot arm span is 320, here is 32	C: Collaborative N: Non-collaborative	0: Silver 1: Black	F: Non-standard customized option, if it is a standard product, it is blank XXX: XXX: Customer label number 01: version number

Specification Parameter

Z-Arm XX32 Collaborative Robot Arm	Parameters
1 axis arm length	160mm
1 axis rotation angle	±90°
2 axis arm length	160mm
2 axis rotation angle	±143°
Z axis stroke	Height can be customized
R axis rotation range	±1080°
Linear speed	1017mm/s (payload 0.5kg)
Repeatability	±0.02mm
Standard payload	0.5kg
Maximum payload	1kg
Degree of freedom	4
Power supply	220V/110V50-60HZ adapt to 24VDC peak power 320W
Communication	Ethernet
Z-axis can be customized in height	0.1m-0.5m
Electrical reserved interface	/
Optional accessories	Z-EFG-8S/Z-EFG-12/Z-EFG-20/Z-EFG-20S
Use environment	Ambient temperature: 0-45°C Humidity: RH20-80 (no frost)
I/O port digital input (isolated)	9+3
I/O port digital output (isolated)	9+3
I/O port analog input (4-20mA)	/
I/O port analog output (4-20mA)	/
Robot arm height	500mm
Robot arm weight	180mm stroke net weight 11kg
Base size	200mm*200mm*10mm
Distance between base fixing holes	160mm*160mm with four M5*12 screws
Collision detection	√
Drag teaching	√
Emergency stop	√
Debug/Online upgrade (USB port)	√

Motion Range and Dimensions

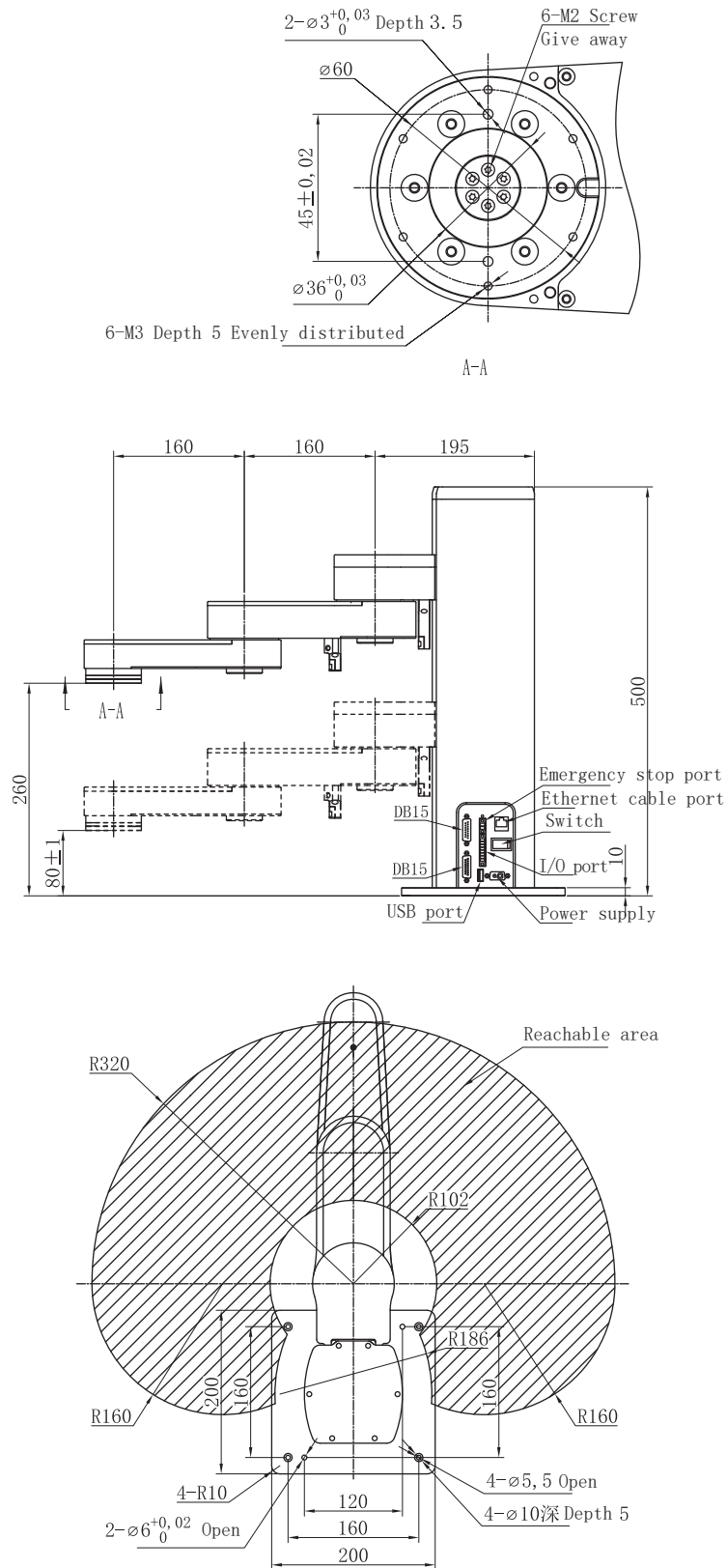

Remark:

1. There is a cable below the arm of the machine, which is not shown in the figure, please refer to the actual product.
2. Some hardware of the control panel of the robot arm is not shown in the figure, please refer to the actual product.

Interface Introduction

The mounting interfaces of the Z-Arm 1832 manipulator are distributed in 2 positions, the back of the manipulator base (defined as A) and the bottom surface of the end arm (defined as B).

Interface Diagram and Instructions for Use

1. General diagram of the base interface A (shown in Figure 1)

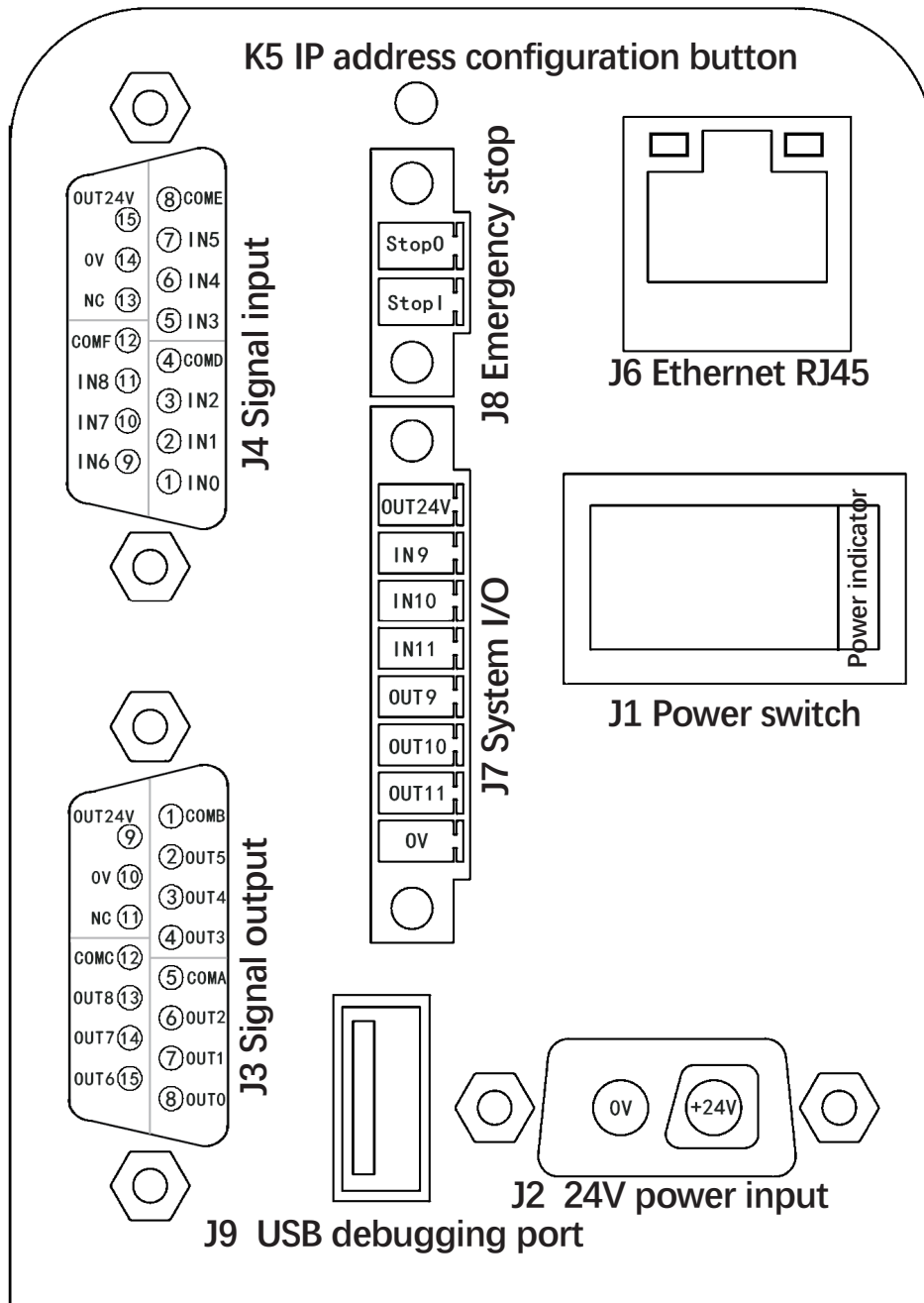

Figure 1

2. Figure 1 interface definition description

- (1) J1 is the power switch interface, which is used to control the power on and off;
- (2) J2 is the power input port, 24V DC voltage input;
- (3) J3 is the I/O output port, with 9 groups of internal optocoupler isolated NPN outputs;
- (4) J4 is the user I/O input port, with 9 groups of internal optocoupler isolated inputs;
- (5) K5 is the IP address configuration button of robot arm , press and hold the button to power on, the robot arm enters the IP address configuration state;
- (6) J6 is the Ethernet port, used for computer communication;
- (7) J7 is the system I/O, there are 3 groups of common ground optocoupler isolation input and output inside;
- (8) J8 is the emergency stop interface, which can be connected to the emergency stop button to control the emergency stop function of the robotic arm;
- (9) J9 is the USB debugging port.

3.The internal circuit design of the J3 and J4 interfaces (as shown in Figure 2)

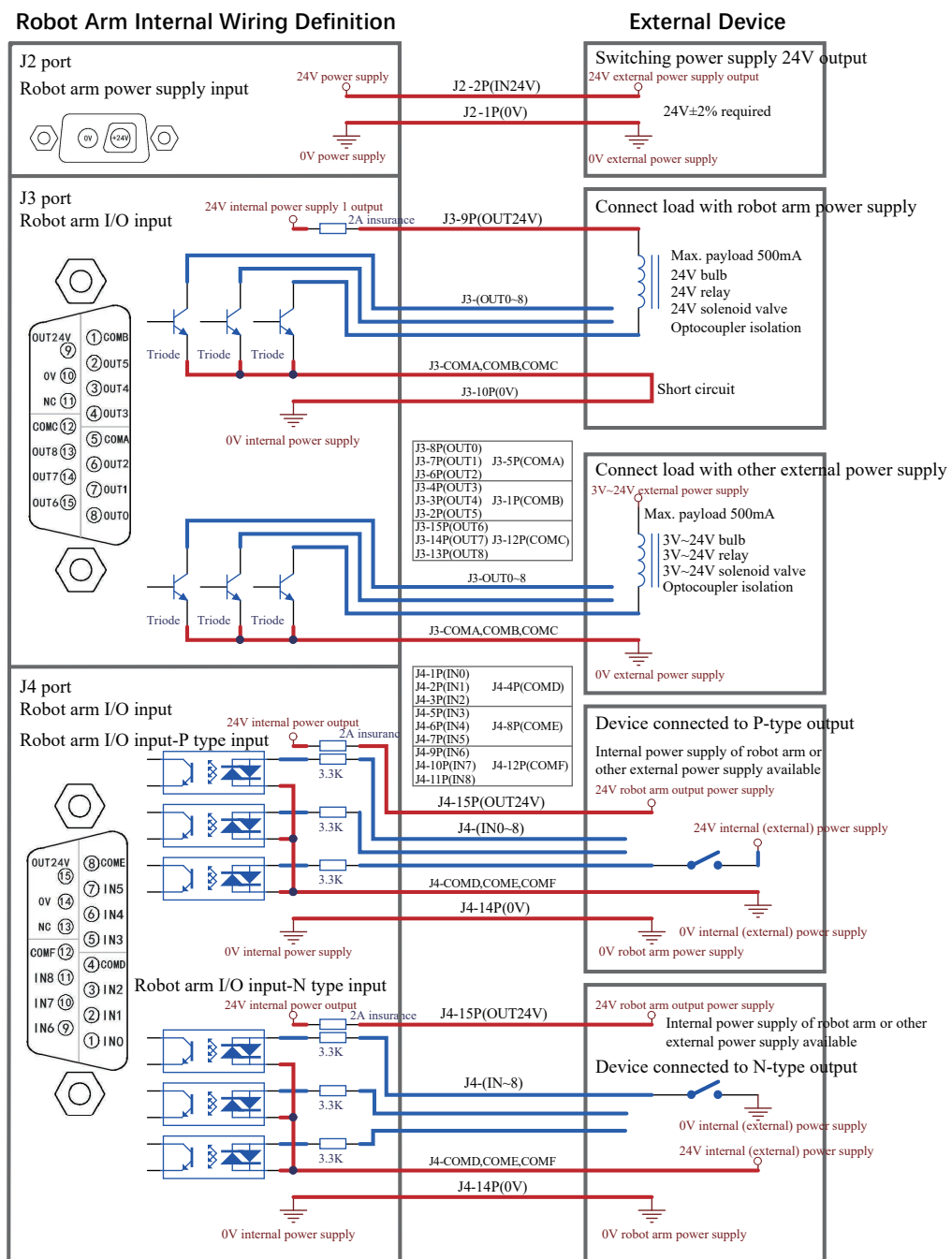

Figure 2

4. J7, J8 interface male socket pin definition (as shown in Figure 3)

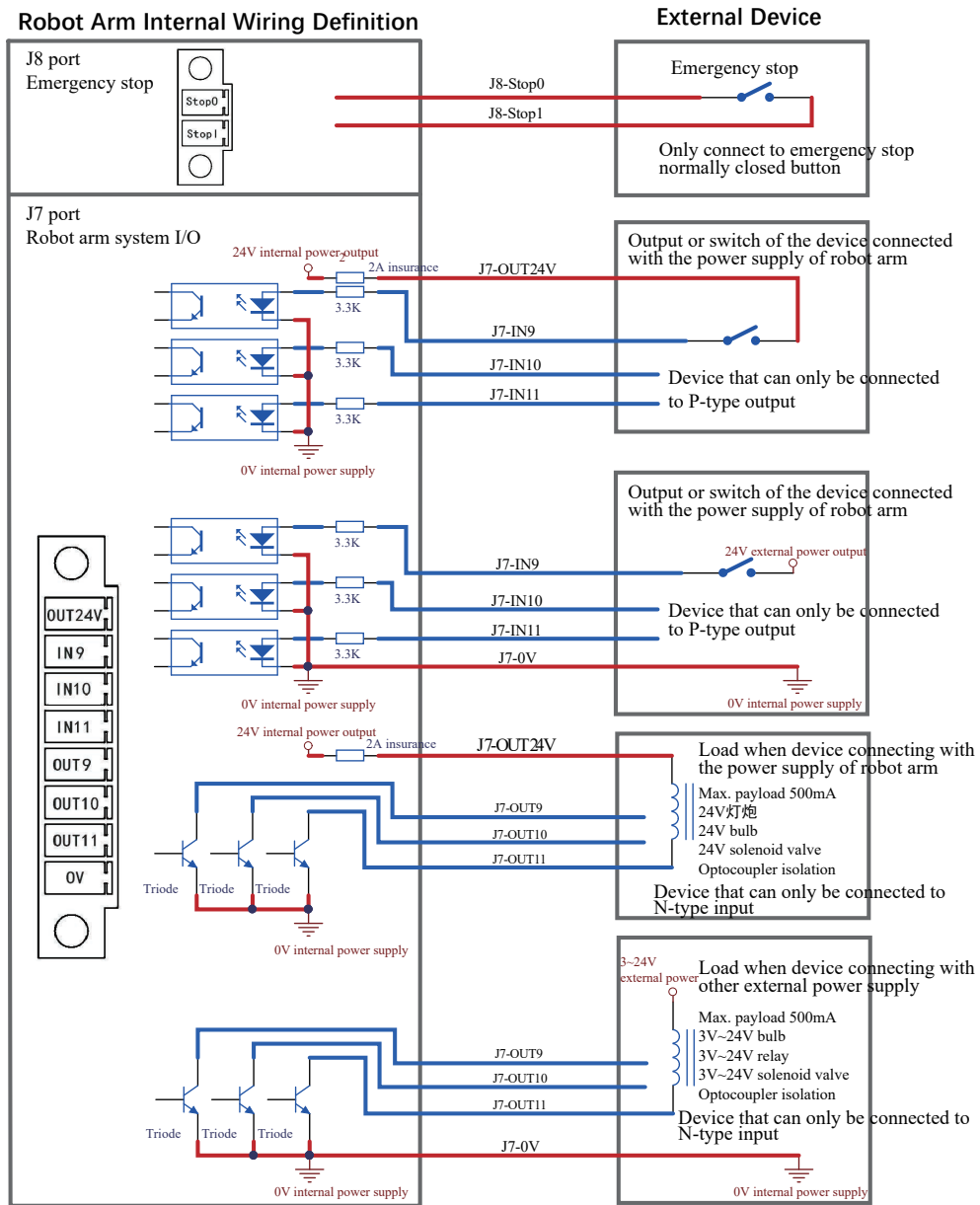

Figure 3

5. Schematic diagram of the EFG-20 electric gripper controlled by the interface at B (as shown in Figure 4)

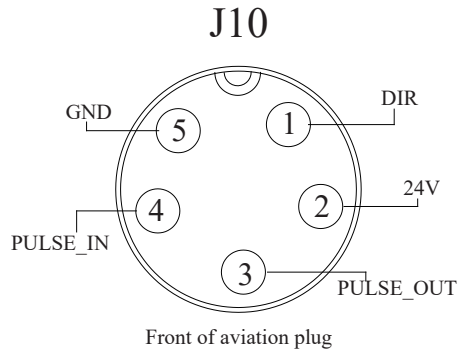

Figure 4

Note:

- Pin 1 is the internal output direction control.
- Pin 2 is the internal power supply 24V output.
- Pin 3 is the internal control pulse output.
- Pin 4 is the pulse control input.
- Pin 5 is the internal power supply GND.

Precautions

1. Payload inertia

The payload center of gravity and the recommended payload range with the Z axis movement inertia are shown in Figure 5.

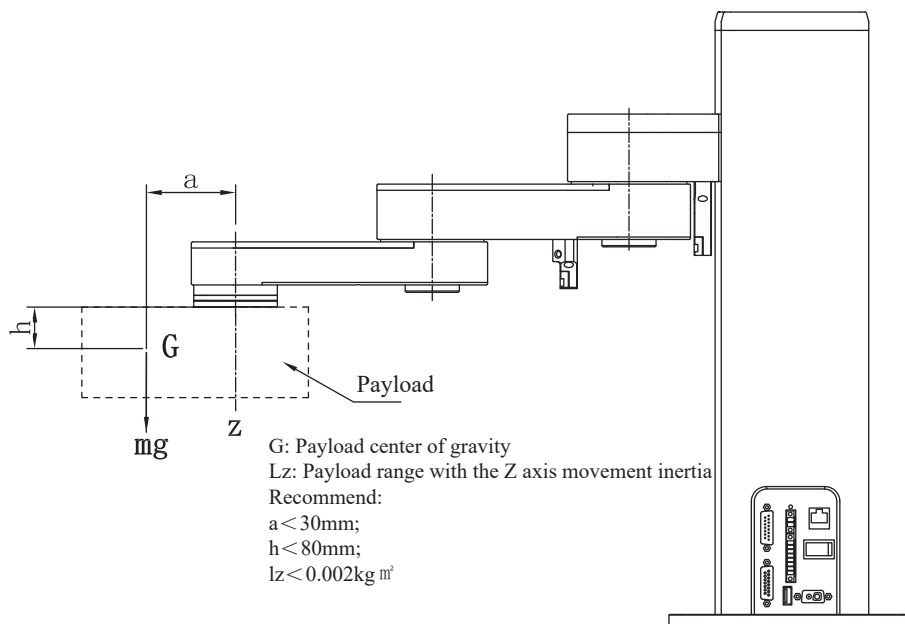

Figure 5

2. Collision force

Trigger force of horizontal joint collision protection: the force of XX32 series is 30N.

3. Z-axis external force

The external force of Z axis shall not exceed 100N, as shown in Figure 6.

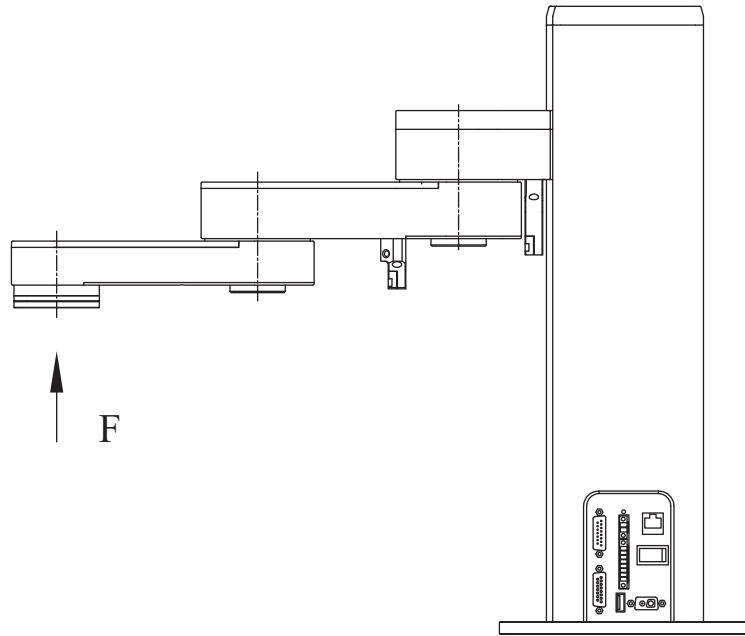

Figure 6

4. Power cable hot-plugging forbidden. Warning when the positive and negative poles of the power supply are reversed (as shown in Figure 7).

5. Do not press down the horizontal arm when the power is off (as shown in Figure 7).

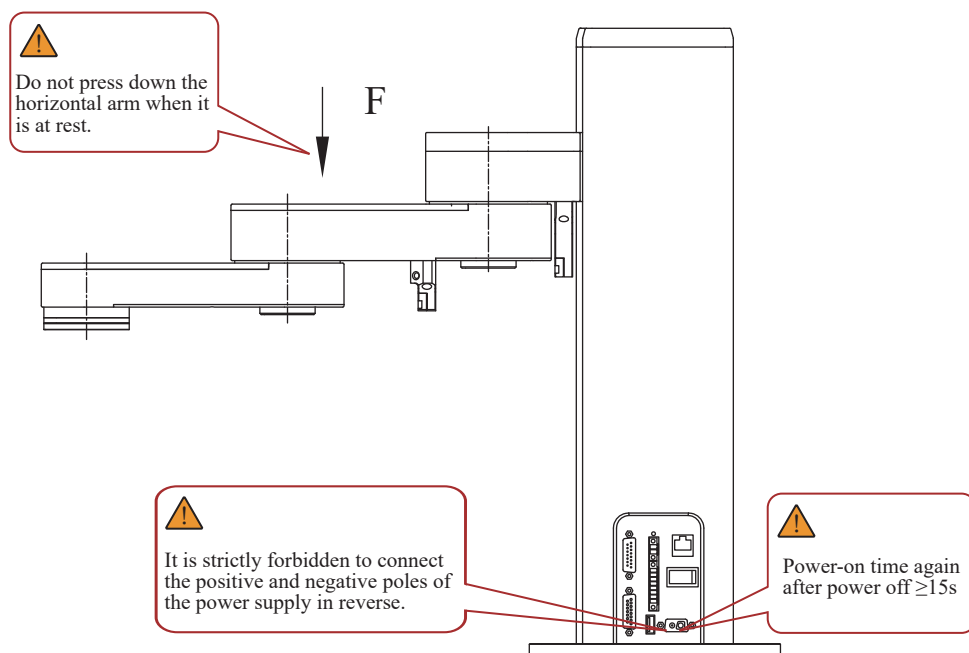

Figure 7

DB15 Connector Recommendation

Recommended model: Gold-plated male head with ABS shell YL-SCD-15M

Gold-plated female with ABS shell YL-SCD-15F

Size Description: 55mm*43mm*16mm

(Refer to Figure 8)



Figure 8

Robot Arm Compatible Grippers Table

Robot arm Model No.	Compatible grippers
XX32	Z-EFG-8S/Z-EFG-12/Z-EFG-20/Z-EFG-20S

Power Adapter Installation Size Diagram

XX32 configuration 24V 500W RSP-500-SPEC-CN power supply

Robot arm body size

Machine case number: 26A Unit: mm

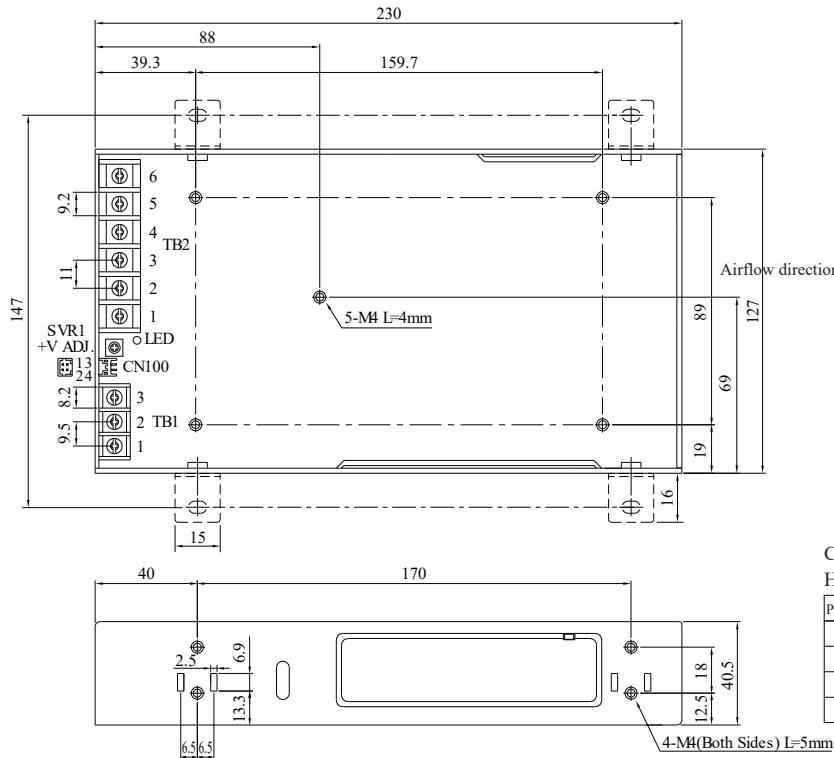

AC input terminal
Pin Definition (TB1)

Pin Number	Pin Function
1	AC/L
2	AC/N
3	FG \perp

DC output terminal
Pin Definition (TB2)

Pin Number	Pin Function
1~3	DC OUTPUT -V
4~6	DC OUTPUT +V

Control Pin Definition (CN100):

HRS DF11-14DP-2DS or equivalent model No.

Pin Number	Pin Function	Corresponding Connector	Terminal
1	-S	HRS DF11-4DS or equivalent level	HRS DF11-**SC or equivalent level
2	+S		
3	RC-		
4	RC+		

Instructions

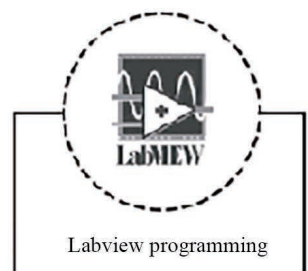
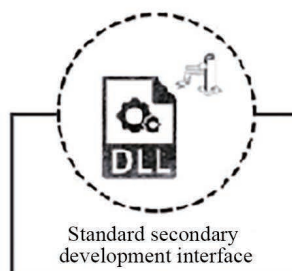
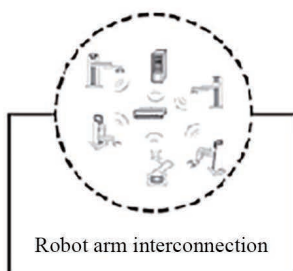
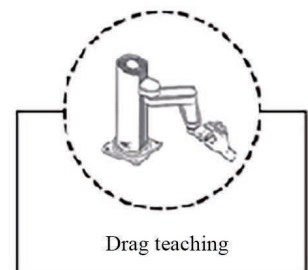
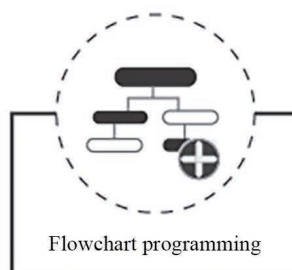
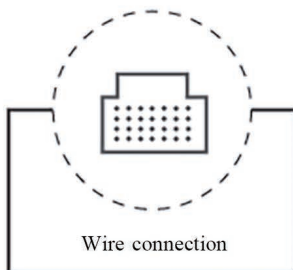
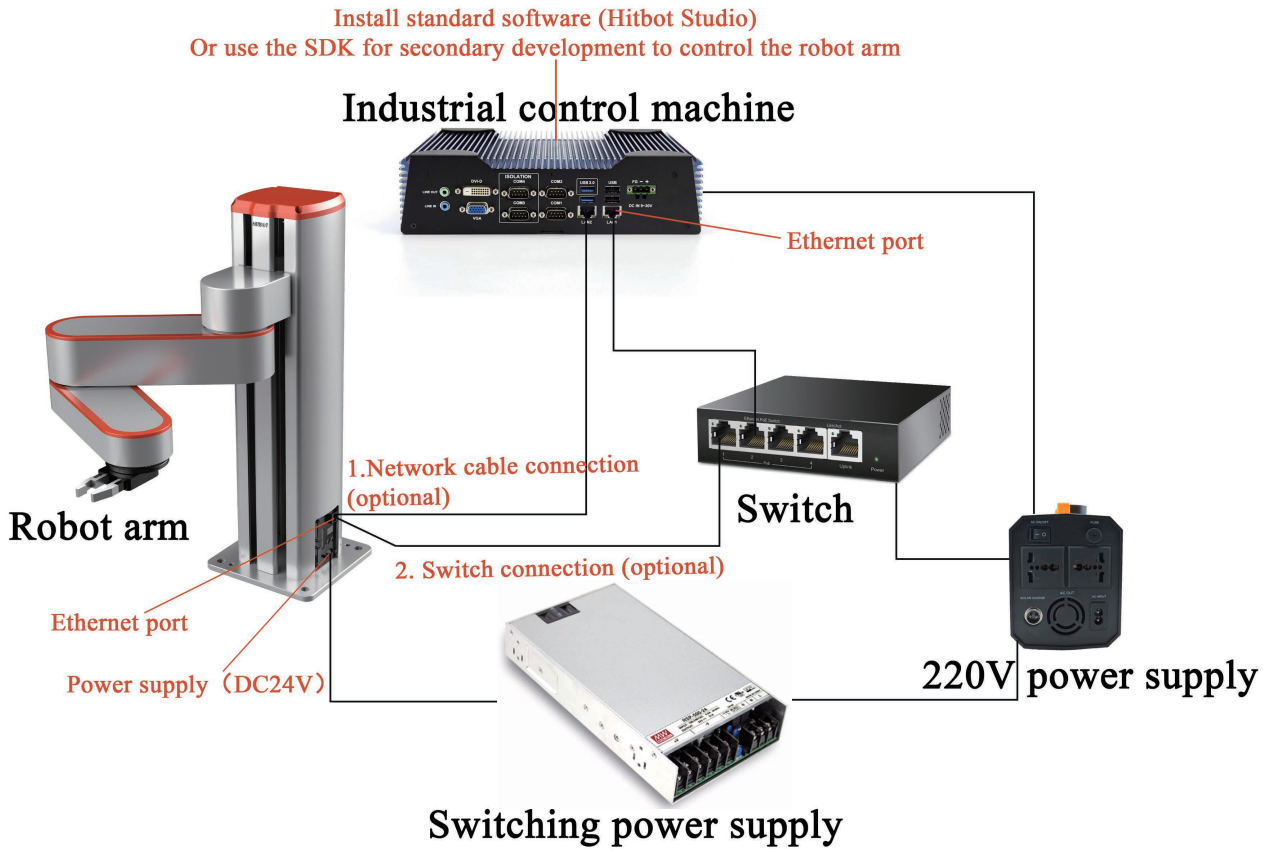

Diagram of the External Use Environment of the Robot Arm





Making Automation Easier

Huiling-tech Robotic Co.,Ltd.

Tel: 0755-36382405

Hotline: 0086-15220259858

Email: Marketing@hitbot.cc

Website: hitbotrobot.com

Address: 2nd Floor, Building E, Huafeng International Robot Industrial Park,
Hangcheng Ave, Xixiang St, Baoan District, Shenzhen City, Guangdong Province, China

V_2023.06.14