

LEBAI 乐白

2023



**Lebai LM3**



# User Manual

For LM3 Robot and L Master<sup>®</sup> v2.2

The contents noted in this User Manual (hereinafter referred to as this manual), including product information and other materials, are for reference only. This manual will be revised and updated irregularly. For the latest online version, go to: <https://l-doc.lebai.ltd/lebai-manual/lebai-manual-en.pdf> to view the *Online User Manual*. Any information is subject to change without prior notice.

Unless expressly stated, nothing in *this manual* shall be construed as any warranty by Shanghai Lebai Robot Co., Ltd regarding personal damage, property loss and fitness for a particular purpose, etc.

Without written permission of Shanghai Lebai Robot Co., Ltd, no enterprise or individual shall extract, compile, translate or reproduce any content of this manual (technical documents, software, etc.) nor disseminate *this manual* in any form (including but not limited to materials and publications).

This manual is translated from Simplified Chinese. In case of any ambiguity or errors, the original Chinese document shall prevail. The Company shall not be liable for any ambiguity arising from the translation.

Copyright © Shanghai Lebai Robot Co., Ltd. All rights reserved.

# Preface

---

Thank you for purchasing the LM3 robot developed by Shanghai Lebai Robot Co., Ltd (hereinafter referred to as *our company*). It is recommended that you carefully read the contents of *this manual* before proceeding, so that you can better use and operate the robot, handle and solve problems in time, and understand the precautions and safety risks. If you have any questions, please visit our official website: <https://lebai.ltd> for more information.

**Table 1** What comes in the box

Index	Item	Amount
1	LM3 robot arm	1
2	Control box	1
3	Power cable	1
4	Accessory package	1
5	User manual (Chinese version)	1
6	Certificate	1
7	Manipulator base (optional)	1
8	Electric gripper (optional)	1

# Contents

---

Chapter 1	Introduction ...	1	2.2.2	Wireless Network Connection.....	21
1.1	Unboxing .....	1	2.3	Login to L Master®	22
1.2	Safety Guidelines ...	1	2.4	Welcome Screen.....	23
1.2.1	Safety Warning Symbols.....	1	2.4.1	System Settings	23
1.2.2	Environmental Conditions for Installation .....	2	2.4.2	Robot Settings .	24
1.2.3	Extra Notices ..	4	2.4.3	Interface Settings.....	27
1.3	Product Composition	5	2.5	Home .....	27
1.4	Technical Specifications .....	7	2.5.1	Robot Status ...	29
1.5	Joints.....	9	2.5.2	Temperature Information .....	30
1.6	Workspace .....	10	2.5.3	Position Information .....	31
1.7	I/O.....	11	2.5.4	Speed Ratio ....	31
1.8	Network Connection	14	2.5.5	Message Center	32
1.9	Robot Installation ...	14	2.5.6	Task History....	34
1.10	End-Effector Installation.....	16	2.6	Start The Robot.....	35
Chapter 2	Start Here .....	18	2.7	Stop The Robot .....	36
2.1	Power On .....	18	2.8	Emergency Stop .....	37
2.2	Connect to the Robot	20	2.9	Turn Off the Robot..	37
2.2.1	Wired Network Connection .....	20	2.10	Capsule Control .....	38
			Chapter 3	Robot Using...	39
			3.1	Scene Editor.....	39
			3.1.1	Editor Type.....	39

3.1.2	Switch Editor Type .....	42	3.3.3.4	Speed and Accelera- tion Time	60
3.2	Drag-and-Drop Teaching.....	43	3.3.3.5	Undo/Redo	60
3.3	Scene Programming	44	3.3.3.6	Delete/Clear	60
3.3.1	Create A New Scene .....	44	3.3.3.7	Delete/Clear Scene	60
3.3.2	Add A Block...	44	3.3.3.8	Loop Cy- cles .....	61
3.3.2.1	Pose Block	45	3.3.3.9	Start A Scene.....	61
3.3.2.2	Gripper Block.....	54	3.3.3.9	Robot Pose Safety In- spection...	62
3.3.2.3	Wait Block	55	3.3.4	Operation Skills	64
3.3.2.4	Notification Block.....	55	3.3.4.1	Quick Search Block.....	64
3.3.2.5	Digital I/O Block.....	56	3.3.4.2	Batch Edit Blocks.....	64
3.3.2.6	Analog I/O Block.....	57	3.3.4.3	Batch Fine- Tuning of Pose Blocks.....	66
3.3.2.7	Payload Block.....	58	3.3.5	Export Scene...	68
3.3.3	Toolbar.....	59	3.3.6	Import Scene...	68
3.3.3.1	Change the Scene Name.....	59			
3.3.3.2	Search.....	59			
3.3.3.3	Semaphore	60			

3.4	Control .....	69	3.6.3	Operation mode	76
3.4.1	Virtual Control.	69	3.6.4	System update .	77
3.4.2	Hardware button.....	70	Chapter 4	Software Re-setting .....	79
3.5	Device .....	72	Chapter 5	Maintenance and Repair .....	80
3.5.1	End Device.....	72	Chapter 6	Service and Support .....	82
3.6	Settings.....	72	6.1	Product Warranty....	82
3.6.1	TCP Settings...	72	6.2	Disclaimer .....	83
3.6.2	Safe Settings ...	74	Appendix A	Guideline .....	85
3.6.2.1	Collision detection..	74			
3.6.2.2	Operational Safety .....	75			

# Chapter **1**

## Introduction

---

### 1.1 Unboxing

Open the packing box and take out the robot arm, control box, power cable, accessory package and other products.

### 1.2 Safety Guidelines

Before installing and powering up the robot, please read this section carefully for the correct installation order and starting method.

#### 1.2.1 Safety Warning Symbols



#### **DANGER! ELECTRICITY!**

When this symbol appears, please pay special attention to the conditions in the warning statement that may lead to electrical hazards. Failure to pay attention may result in injury, death, or equipment damage.



### **Danger/Warning**

When this symbol appears, please pay special attention to the situations in the warning statement that may lead to personal safety and equipment damage. Failure to pay attention may result in personal injury, death, or severe equipment damage.



### **NOTICE**

When this symbol appears, please pay attention to the matters that need attention during the operation. Failure to pay attention may result in faulty operation and accidental injury.

## **1.2.2 Environmental Conditions for Installation**

Before installing the robot, check whether the environmental conditions meet the following requirements, so as to avoid malfunction of the robot or accidental injury.

- Ambient temperature: 0 ~ 40 °C
- Ambient relative humidity: 25% ~ 85%
- Surrounding environment: no corrosive gas or liquid, no oily smoke or salt spray, no dust or metal chips, no radioactive materials, no flammable materials, no electromagnetic noise, no radioactive materials, and try to avoid direct sunlight.
- Workspace: sufficient space for safe work must be ensured (drag-and drop teaching, maintenance, etc.).
- Mounting surface: When installing the robot, choose a sturdy and shockproof surface that can withstand at least 10 times the



full torsion force of the base joint (the maximum torque of the base joint is 40 N·m) and at least 5 times the weight of the robot (the body weight of the robot is 9.5 kg).

**NOTICE**

- Operating environment: Avoid water, dust and oily fume. If put in similar scenes, the equipment shall be shielded.
- Do not disassemble the machine. Otherwise, product damage may result.
- During the disassembly and assembly process of the product, handle it gently to prevent bumping and dropping.

**DANGER**

The robot needs to be safely placed on a solid shock proof surface. Please ensure that the operation of the robot will not be affected by impact or vibration. Otherwise, the loosening of the robot installation screws may cause the robot to tip over, causing accidental injury or property damage.

**DANGER**

Please ensure that there is no flammable gas, flammable dust, and flammable liquid, etc. in the installation environment, otherwise an explosion or a fire may result.



**DANGER**

Please ensure that there is no water, corrosive gas, metal shavings, dust, etc. in the installation environment, and ensure that the temperature and humidity of the installation environment are within the allowable range, otherwise it may cause the robot to malfunction, break down or leak electricity.



**DANGER**

Do not use it in an environment that exceeds the range of the robot's antielectromagnetic interference, electrostatic discharge capability, etc., otherwise it may cause the robot to shut down or change its trajectory, resulting in unpredictable danger. footnoteSee [Appendix A Guideline \(page 85\)](#) for details.

### 1.2.3 Extra Notices

The control box should be placed horizontally, and there should be at least 5 cm gaps between the air inlets and outlets on both sides to ensure air circulation and heat dissipation.



**DANGER! ELECTRICITY!**

The control box and cables should avoid contact with any liquid. Do not touch the plug with wet hands, otherwise electric shocks, even casualties may result.

**DANGER**

The control box must not be exposed to dust or a humid environment that exceeds the IP20 protection level. Pay close attention to the environment with conductive dust.

## 1.3 Product Composition

The LM3 Robot is mainly composed of a robot arm and a control box. The robot arm has 6 rotary joints, i.e. 6 degrees of freedom (DoF). As shown in [Figure 1.1](#), the robot joints include a base (joint 1), a shoulder (joint 2), an elbow (joint 3), wrist 1 (joint 4), wrist 2 (joint 5) and wrist 3 (joint 6).

The robot arm (hereinafter referred to as *the robot*) is the actuator of the robot product. The base is where the robot is installed. The shoulder and elbow can perform larger movements. Wrist 1 and wrist 2 can perform more precisely, and wrist 3 can connect the end effectors.

The control box is the control part of the robot system, which can control the position and posture of the robot in the workspace, and connect the electrical input and output terminals of the equipment. To ensure safe operation in practical applications, an emergency stop button (optional) is usually externally connected to the control box. For convenient usage, an external power button (optional) can also be connected.

As shown in [Figure 1.2](#), the control box is connected to the robot via the robot cable. After connecting and powering up<sup>1</sup>, users can

---

<sup>1</sup>Please refer to [Chapter 2 Start Here \(page 18\)](#).

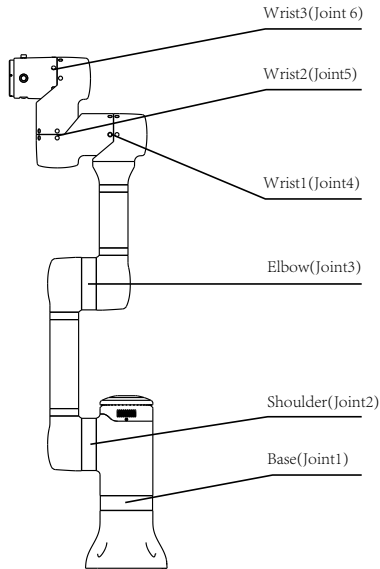

**Figure 1.1** Robot Joints

access the robot's L Master<sup>®2</sup> system to control the robot via the browser<sup>3</sup> of a computer, tablet, mobile phone or other terminals, and view various status information of the robot.

---

<sup>2</sup>L Master<sup>®</sup> is a robot control system tailored by *our company* for the robot. All visual operations and control of the robot must be performed after logging into the L Master<sup>®</sup> system.

<sup>3</sup>It is recommended to use Google Chrome, Microsoft Edge or other modern browsers based on the Webkit kernel to get a better user experience.

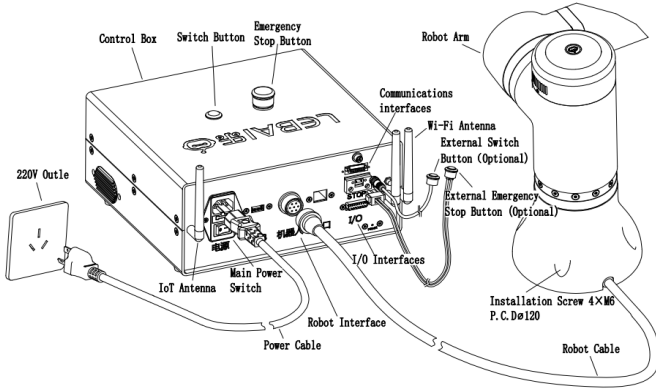

Figure 1.2 Robot and control box

## 1.4 Technical Specifications

See [Table 1.2](#) and [Table 1.1](#).

**Table 1.1** Technical specifications of the control box

Size	270 × 250 × 130(H) mm
Weight	3.8 kg
Power supply	100 ~ 240 V(AC), 50 ~ 60 Hz
Cable length	2 m
Protection level	IP20
Protocol	Ethernet

**NOTE.** The typical power consumption of the control box and the robot is

130 W

**Table 1.2** Technical specifications of the robot

DoF	6
Working radius	638 mm
Payload	$\leq 3$ kg
Weight	9.5 kg
Repeatability	$\pm 0.5$ mm
TCP Speed	$\leq 2$ m/s
Ambient humidity	25~85%
Ambient temperature	0~40 °C
Protection level	IP54
Power supply	48 V(DC)
Install directions	Up, Down and Side
Installation area	$\approx 160$ cm <sup>2</sup>

Technical specifications of the control box is shown in [Table 1.3](#):

**Table 1.3** Technical specifications of the control box

Parameters	Minimum	Typical	Maximum	Unit
Nominal Voltage	100	220	240	V(AC)
External Utility Fuse	18	20	22	A
Input Frequency	47	50	63	Hz
Nominal Operating Power	90	130	400	W

## 1.5 Joints

See [Table 1.4](#).

**Table 1.4** Lebai robot joints

Joint	Motion limit	Maximum speed
Joint 1	Unlimited	180°/s
Joint 2	Unlimited	180°/s
Joint 3	Unlimited	180°/s
Joint 4	Unlimited	180°/s
Joint 5	Unlimited	180°/s
Joint 6	Unlimited	180°/s

**NOTE.** The joint rotation range is unlimited mentioned above exclude the robot's selfinterference. Due to the actual motion scene, the selfinterference conditions can be different.

## 1.6 Workspace

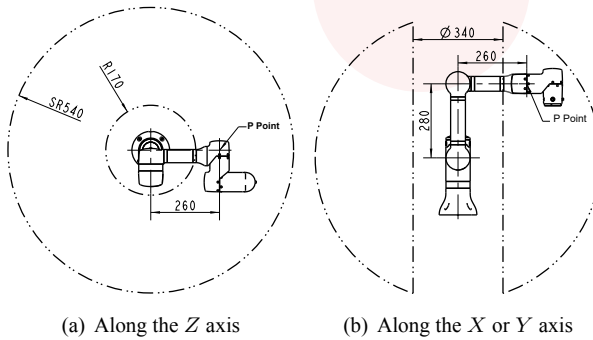

**Figure 1.3** Schematic diagram of Lebai robot workspace

The workspace of the LM3 Robot refers to the area circled with a radius of 540 mm around the base joint. As shown in [Figure 1.3](#), the range shown by the twodot chain line is the best operating area of point *P*.



## 1.7 I/O

The I/O provided by LM3 consists of two parts: the control box and the flange. According to different application scenarios, you can choose the I/O at different locations to implement the corresponding I/O operation.

(1) As shown in [Figure 1.4](#) and [Table 1.5](#), the robot control box provides:

- 4 digital inputs, 4 digital outputs.
- 2 analog inputs, 2 analog outputs.

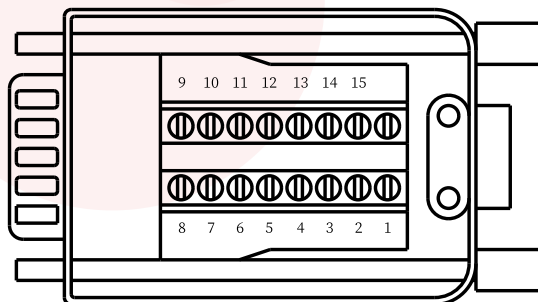

**Figure 1.4** Schematic diagram of the control box I/O hardware port

**Table 1.5** Control box I/O description

Index	Function	Parameters
1	Positive pole	24 V
2	Analog output 1	Voltage: output 0 ~ 10 V
3	Analog output 2	Current: output 4 ~ 20 mA
4	Digital output 1	
5	Digital output 2	PNP, output voltage 24 V
6	Digital output 3	Total maximum current 2 A
7	Digital output 4	
8	Negative pole	
9	Analog input 1	Voltage: input 0 ~ 10 V
10	Analog input 2	Current: input 4 ~ 20 mA
11	Digital input 1	
12	Digital input 2	PNP, input voltage 3 ~ 30 V
13	Digital input 3	
14	Digital input 4	
15	Negative pole	

(2) As shown in [Figure 1.5](#) and [Table 1.6](#), provided on the end flange:

- 2 digital inputs.
- 2 digital outputs.

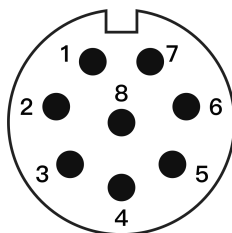

**Figure 1.5** Schematic diagram of the flange I/O hardware port

**Table 1.6** Flange I/O description

Index	Function	Parameters
1	Positive pole	Voltage 24 V, Maximum current
2	Negative pole	2 A
3	Digital output 1	PNP, output voltage 24 V
4	Digital output 2	Total maximum current 1.5 A
5	485A	RS485 bus high level
6	485B	RS485 bus low level
7	Digital input 1	PNP, input voltage 3 ~ 30 V
8	Digital input 2	

(3) Communication interfaces Figure A and Table A :

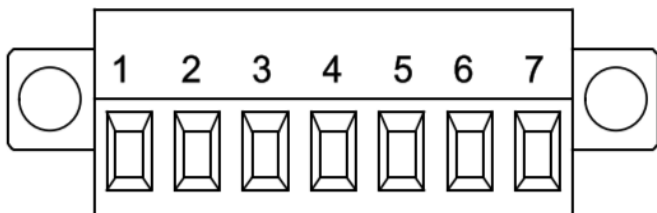

Figure A

Index	Function
1	RS485A
2	RS485B
3	TX-232
4	RX-232
5	TX-TTL
6	RX-TTL
7	GND

Table A : Description of communication interface

## 1.8 Network Connection

LM3 provides three different connection methods: Ethernet, WiFi (2.4 GHz) hotspot network, and 4G IoT (Internet of Things) network. Ethernet and WiFi network connections are provided for operating and connecting to robots. 4G IoT connections are currently only used for data reporting of device basic information<sup>4</sup> (for device health monitoring).

## 1.9 Robot Installation

As shown in [Figure 1.6](#), the LM3 robot supports three install directions: up, down, and side (note that the robot cable outlet must face downwards when sidemounted).

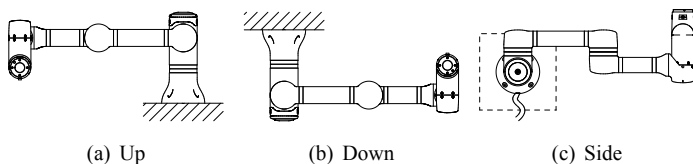

**Figure 1.6** Installation mode of the robot

Use the 4 M6 screws in the robot accessory kit to correspond to

---

<sup>4</sup>Equipment basic information is limited to: equipment name, equipment network connection type and status, software system version, system operation error information. Customer business data (including but not limited to scene data) is not included. The company will obtain your prior authorization and consent before reporting any other information.

the 4 mounting holes on the robot base ([Figure 1.7](#)). It is recommended to tighten these screws with a torque of 9 N·m. If you need to adjust the robot position more accurately, you can also drill 2 holes with a diameter of 5 mm and fix them with pins.

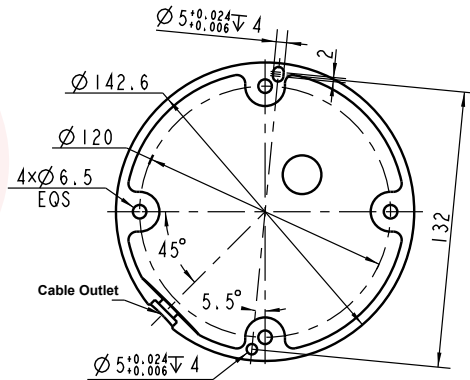

**Figure 1.7** Robot base view



#### NOTICE

- Fix screws in all mounting holes of the robot.
- During the installation, hold the robot until all the screws on the base are tightened.



#### WARNING

Do not fix the robot (including the control box) in an unstable position, otherwise it may fall and thus damaged.

## 1.10 End-Effector Installation

As shown in [Figure 1.8](#), there are 4 M6 threaded holes on the front of the end flange of the robot, which are used to connect the end-effector and the robot; there are 4 M3 threaded holes on the side of the flange, which are used for the installation of Lebai lightweight end-effector. Under normal use and excluding external collisions, the end of the robot (including effectors) can bear a maximum load of 3 kg.

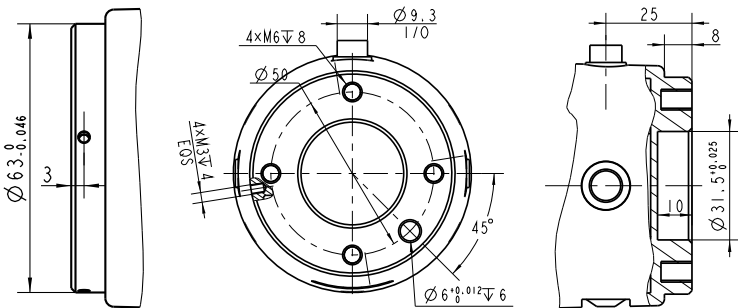

**Figure 1.8** Robot end flange port

The maximum allowable payload of the robot depends on the center of gravity (CoG) offset, see [Figure 1.9](#). The CoG offset is defined as the distance between the center of the effector output flange and the CoG.



**Figure 1.9** Effective payload



**WARNING**

- The load condition should be within the range shown in the chart.
- The effective load shown in the chart indicates the maximum load capacity. Under no circumstances should it exceed the maximum weight shown in the chart.
- Exceeding the max effective payload will cause premature damage to the internal parts of the robot.



# Chapter 2

## Start Here

---

### 2.1 Power On

Before powering on the robot, please reconfirm that you have read [1.2 Safety Guidelines \(page 1\)](#) and are now following it to eliminate potential risks and ensure safe operation.

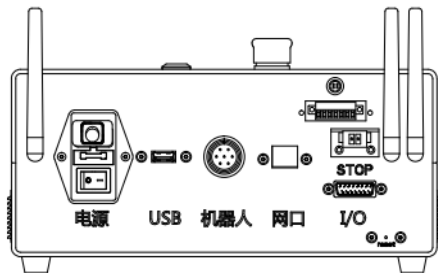

**Figure 2.1** Schematic diagram of the control box back panel

- (1) Put the robot cable into the “Robot” port of the control box.
- (2) Plug the power cord into the control box and connect the power plug to the 220 V AC outlet.

- (3) Ensure that the emergency stop button on the top of the control box is in the released<sup>1</sup> state.
- (4) Turn on the red main power switch on the back panel of the control box, and the switch indicator light is on.
- (5) Long press (for about 3 seconds) the switch button on the top of the control box or the external switch button (optional) until the indicator light of the switch button on the top of the control box turns blue. Wait for the light on the shoulder of the robot comes up to mark the complete of the poweron operation of the control box and the robot.



### **DANGER**

- Make sure that the power strip of the control box is well grounded.
- Make sure that the input current of the control box power supply is protected by the leakage protection device and the appropriate overcurrent protection device.
- Make sure that all cables are properly connected before the control box is powered on, and always use the original power cord correctly.

---

<sup>1</sup>When the emergency stop button is pop-up, it is in the released state. Conversely, when it is pressed, it is in the locked state.



### **WARNING**

- It is forbidden to disconnect or pull the robot cable when the robot is started.
- Do not extend or modify the robot cable.
- Do not damage the power cord or place heavy objects on the power cord.
- Do not use damaged or noncompliant outlets.
- Do not allow dust or mill scales to adhere to the power plug and socket.

## **2.2 Connect to the Robot**

LM3 supports both wired network connection and wireless network connection. The wireless network connection currently only supports access to the WiFi hotspot network integrated in the control box.

### **2.2.1 Wired Network Connection**

Use a network cable to connect the network port on the back panel of the control box with the LAN port of the router or switch, and ensure that the computer, tablet, mobile phone or other graphical terminal device used to operate the robot is connected to the same network as the robot.

The connection diagram of the wired network is shown in [Figure 2.2](#):

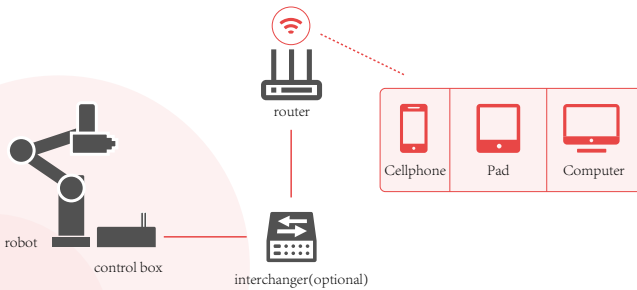

**Figure 2.2** Wired network connection topology diagram



**Figure 2.3** Wireless network connection topology diagram

## 2.2.2 Wireless Network Connection

After the robot leaves the factory, a WiFi hotspot with a name same as the device name<sup>2</sup> will be enabled by default. The format of the device name is Lebai-123456 (the last 6 digits are random characters), and the default password is 88888888 (eight “8”s). You can connect to the WiFi hotspot network corresponding to the device name through the WiFi function of a computer, tablet, mobile phone

<sup>2</sup>The device name can be found on the nameplate of the control box.

or other graphical terminal device to connect and control the robot.

## 2.3 Login to L Master<sup>®</sup>

Learning the operation of the L Master<sup>®</sup> system will help you to use our robot products more conveniently and quickly. Open a browser on your computer, tablet, mobile phone or other graphical terminal device and enter the following address in the address bar:

- If you use a wired network: `http://<IP>`<sup>3</sup>
- If you use a wireless hotspot: `http://10.20.17.1`

After loading, you will enter the login page. Please enter the default code: 1111, then click **LOGIN** or press **Enter**.

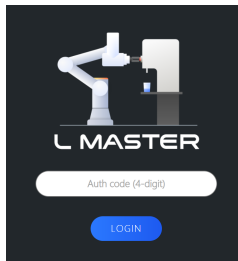

**Figure 2.4** Login to L Master<sup>®</sup>

---

<sup>3</sup>The wired network address can be viewed in the device list on the router page of the connected network. The viewing method varies according to the brand and type of the device. For the specific viewing method, please refer to the router device manual or contact the corresponding device manufacturer.

## 2.4 Welcome Screen

To login to L Master<sup>®</sup> for the first time after the robot is unpacked and powered on, first, you need to follow the instructions on the setup guide page to set up the robot before initial use.

### 2.4.1 System Settings

The first step is to customize the language, time zone, and time in System Settings.

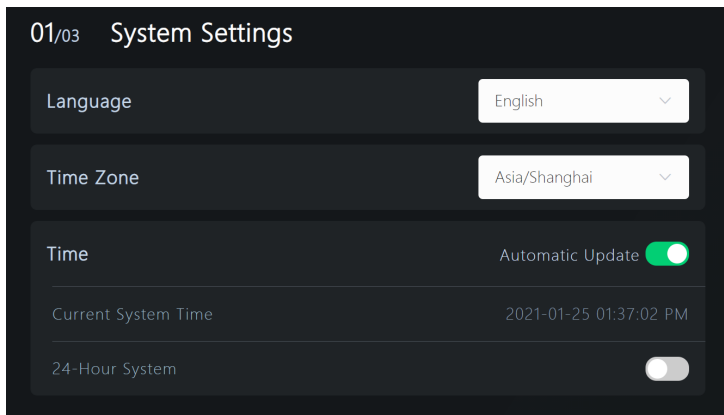

**Figure 2.5** System Settings

## 2.4.2 Robot Settings

The second step is to set the robot installation mode, operation mode and collision detection in **Robot Settings** .

### (1) Installation

According to the actual install direction, refer to the **Icon comparison table** in **Figure 2.6** to choose up, down, or side installation.

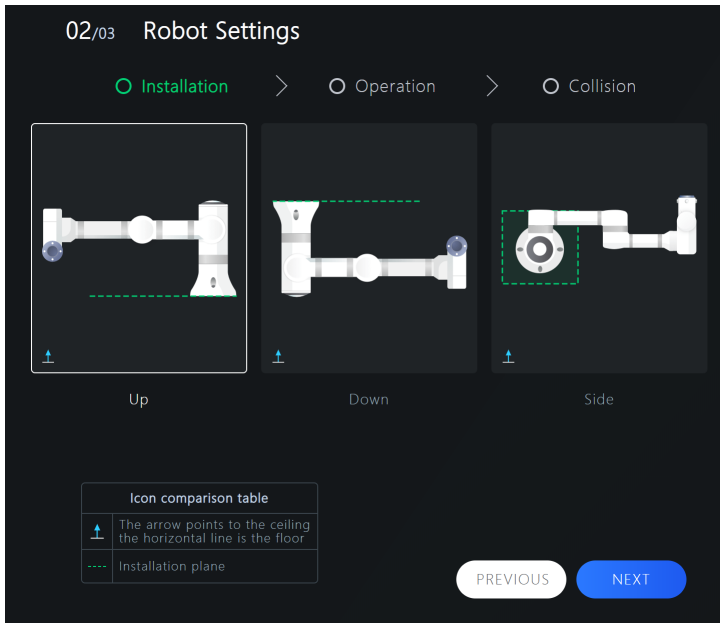

**Figure 2.6** Install direction

**DANGER**

The choice of install direction must be consistent with the actual install direction, otherwise it may cause accidental injury.

**(2) Operation**

You can choose between the **Normal Mode** and **Expert Mode**.

The **Normal Mode** is suitable for novices who have no programming basics, thus there is no need to understand any logic or codes. The **Expert Mode** is suitable for advanced users who have some basic knowledge in programming and logic.

You can choose the appropriate operation mode according to your own situation.

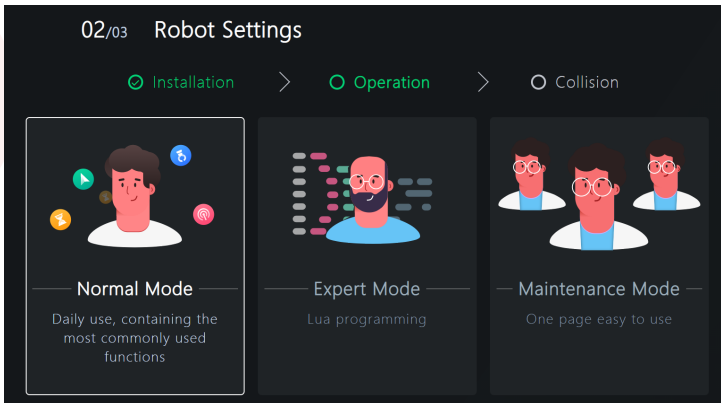
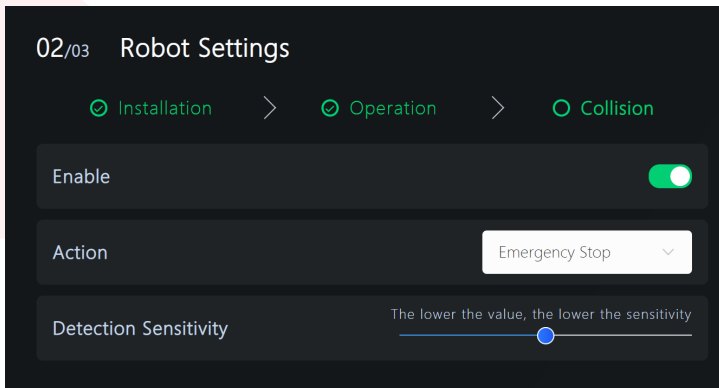

**Figure 2.7** Operation mode



### (3) Collision

The detection switch is on by default, and the **Action** is set to **Emergency Stop** by default. You can choose between **Emergency Stop** or **Pause**, and you can drag the lever to adjust the **Detection Sensitivity**. Click **NEXT** to enter the interface settings.



**Figure 2.8** Collision detection



#### **DANGER**

When the robot is operating, no matter whether the collision detection function is turned on or not, it is forbidden to enter the robot's workspace<sup>a</sup> without protection, otherwise there is a risk of personnel getting hit by the robot.

<sup>a</sup>See [1.6 Workspace \(page 10\)](#).

### 2.4.3 Interface Settings

The third step is to set the interface theme in the **Interface Settings**. It is recommended to use the **Dark theme**.

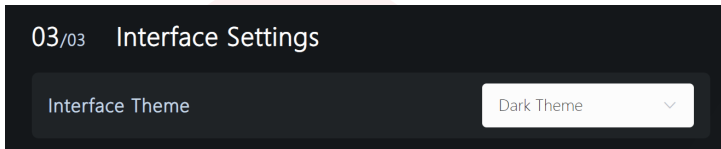

**Figure 2.9** Interface Settings

Click **FINISH** to enter the home page of L Master<sup>®</sup>.

## 2.5 Home

The L Master<sup>®</sup> homepage is divided into six areas: left panel, status area, control area, main function entrance, task history, and title bar at the top.

- The left panel displays the robot temperature and joint temperature, the position and posture in the coordinate space, and the joint angle in the joint space.
- The status area displays the realtime status of the robot.
- The control area contains the robot's Start and Stop button, software Teaching buttons and Speed ratio adjustment controls.
- The main function entrance contains three main function entrances: **Scene**, **Control** and **Device**.
- Task History contains a list of all task histories.
- The right side of the top title bar contains Settings, Message Center and Logout.

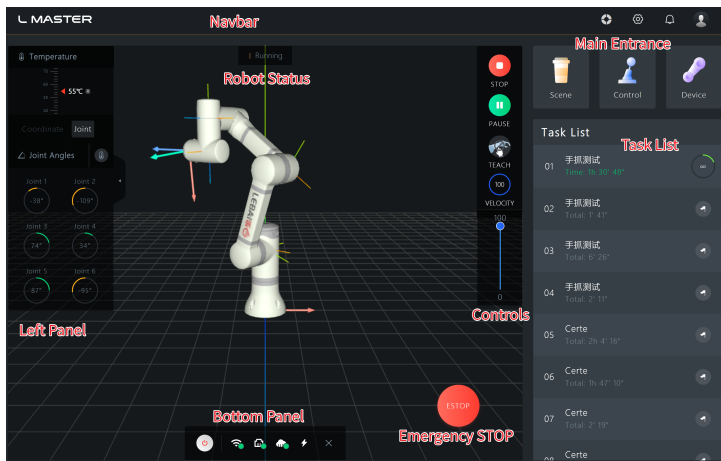

Figure 2.10 L Master® Home



## 2.5.1 Robot Status

The robot status area displays the current status of the robot. For details, please refer to [Table 2.1](#).

**Table 2.1** Robot status list

Code	Status	Detail
-1	System Error	Software control system exception
0	Hardware Error	Hardware communication failure
1	Emergency Stopped	Please confirm the safety
2	Initializing	In initialization
4	Initialized	Power on
5	Idle	In the idle state
7	Running	In operation
8	Updated	System update
9	Starting	Initialized to Idle process
10	Stopping	The idle state goes to the stopped state
11	Teaching	In teaching mode
12	Stopped	In the stop state, not the emergency

## 2.5.2 Temperature Information

As shown in [Figure 2.13](#), the left panel of the L Master<sup>®</sup> homepage displays the temperature<sup>4</sup> of the robot in real time. The normal temperature of each joint is between room temperature and 65 °C. Select the **Joint** tab in the left panel, the joint angles of 6 joints are displayed by default. Click the  icon on the right of the **Joint Angle** to observe the temperature changes of Joint 1 to Joint 6 in real time; as shown in [Figure 2.11](#), click the  icon on the right of the **TEMPERATURES** to switch back to the joint angle display.



### WARNING

When the Joint Temperature shows a value more than 65 °C, do not touch the outer surface of the robot, otherwise there is a risk of thermal burns. Please stop the robot immediately, and check whether the current robot load exceeds the rated payload by 3 kg or whether the robot bumped against external objects after the temperature of the robot drops to normal.

---

<sup>4</sup>The display of the complete machine temperature takes the maximum value of the controller CPU temperature in the control box and the temperatures of all joints of the robot. When there is a chip icon displayed on the right side of the overall temperature value, it means that the CPU has the highest temperature at the moment; when there is a joint plus number icon displayed, it means the joint corresponding to the number has the highest temperature.

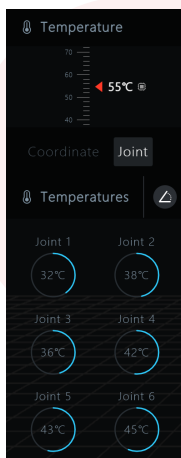

**Figure 2.11** Joints' temperature

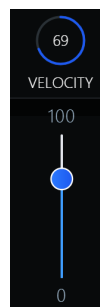

**Figure 2.12** Speed Ratio

### 2.5.3 Position Information

L Master<sup>®</sup>The left panel of the L Master<sup>®</sup> homepage synchronizes with the position information of the robot in real time, including the Coordinate Space and Joint Space. As shown in [Figure 2.13](#), the Joint Space displays the realtime data of the six joint angles of the robot; as shown in [Figure 2.14](#), the Coordinate Space displays the realtime data of the position and posture of the robot in the coordinate space.

### 2.5.4 Speed Ratio

Click the Speed icon in the control area of the L Master<sup>®</sup> homepage, and drag the slider in the expanded sliding bar or click the sliding



**Figure 2.13** Joint space

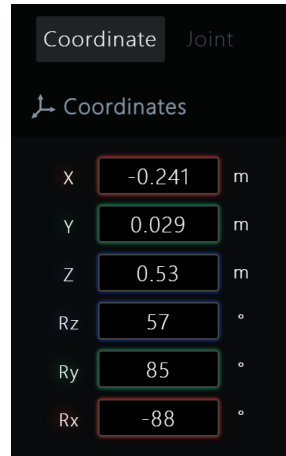

**Figure 2.14** Coordinate space

bar to adjust the robot's running speed ratio. The range of the ratio is 0 ~ 100.

## 2.5.5 Message Center

In the Message Center, you can view prompts, warnings, and notifications of software and hardware abnormalities of the robot.

Move the mouse to the message icon  in the upper right corner of the L Master<sup>®</sup> homepage to open the Message Center.

There are two ways to search for messages in Message Center,

- (1) Search for message notifications by keywords.
- (2) By filtering the following types of message notifications:

 **Info** Information reminder message.

 **Warning** A warning level reminder during system running which generally does not affect system use.

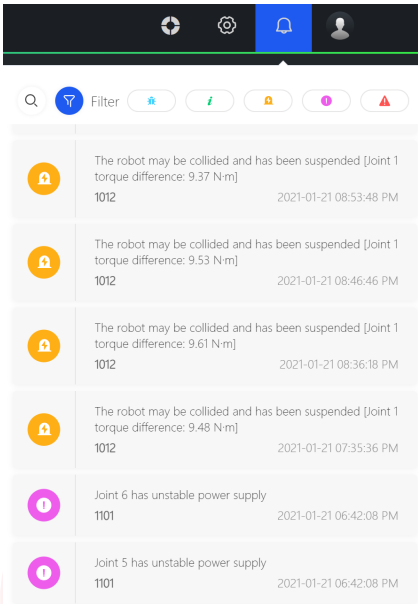

**Figure 2.15** Message Center

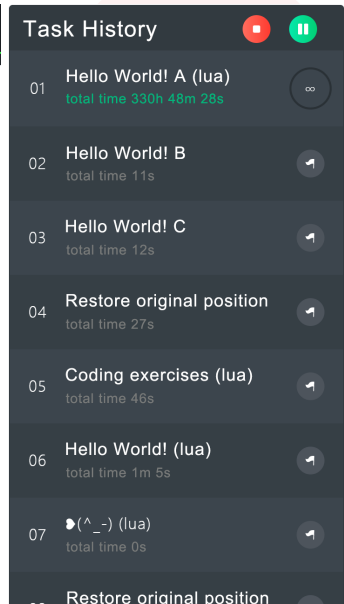

**Figure 2.16** Task History

- Error** There is an error in the system, and you need to pay attention to the frequency with which the error occurs. If it occurs frequently, click the error to view the solution as soon as possible or get in touch with our company in time.
- Fatal** The system has a severe error. There is an operational risk in the system, or the system is no longer operational. At this time, the robot must be shut down immediately. Check the solution or get in touch with our company in time.



As shown in [Figure 2.15](#), the number in the lower left corner of a message is the error code. Click the error code link to jump to the corresponding error code solution page on our company's official website, where you can find the corresponding problem's explanation and solution based on the error code.

## 2.5.6 Task History

The task history list displays running and completed tasks in a chronological order. When a task is running, the control buttons for **STOP**, **PAUSE** or **RESUME** will appear in the task history title bar. In the task history list:

- The right side of a running task displays the current number of runs and the progress of the current running cycle.
- The  **RERUN** button is displayed on the right side of a completed task. Click to rerun the currently selected task.

Click the task name of a task in **Task History** to enter the scene editing page corresponding to the task.



### WARNING

When running a scene, the tasks of the scene will be listed in the task history list. After a task is completed, if you click the **RERUN** button, the currently executed task will have the scene data of the previous execution of the task. Even if the scene changes after the task is completed, the rerunning of the task will be unaffected. The rerun task is not affected by the data change of the scene but subject to the scene data of the last run.

## 2.6 Start The Robot

Enter L Master<sup>®</sup> (see [Figure 2.17](#)), click the start button in the control area, after a short **STARTING**, the status area on the homepage turns to **IDLE**, indicating that you have successfully started the robot.

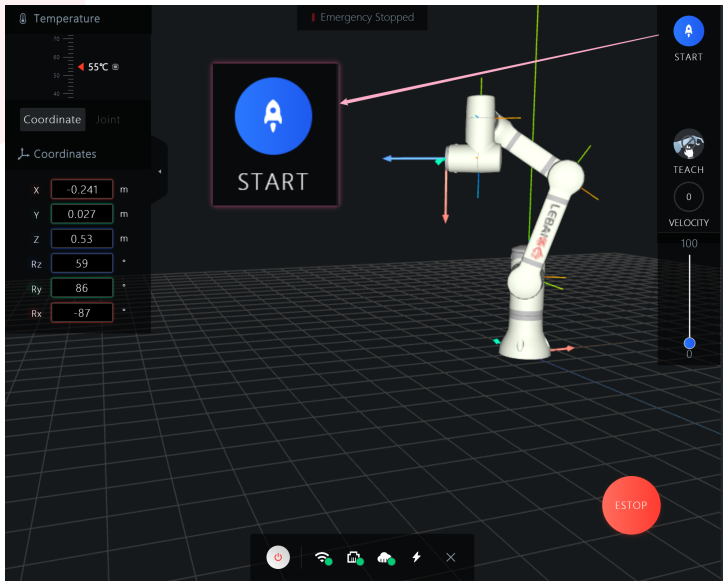

**Figure 2.17** Start The Robot

## 2.7 Stop The Robot

When the robot is **RUNNING** or **IDLE**, you can click the red stop button on the homepage or in the capsule control area as shown in [Figure 2.18](#). After a short **STOPPING**, when the robot status changes to **STOPPED**, it means you have successfully stopped the robot.

## 2.8 Emergency Stop

**ESTOP** The red emergency stop button at the bottom right of L Master<sup>®</sup>.

**Hard ESTOP** Press the emergency stop button (red raised) on the top of the control box or the external emergency stop button (optional).



### NOTICE

After using the hard emergency stop operation, the emergency stop operation will not be automatically released. You need to turn the emergency stop button clockwise to release it after unlocking.

## 2.9 Turn Off the Robot

- (1) Firstly, stop or emergency stop the robot.
- (2) Long press the control box switch button or use an external switch button (optional) until the blue indicator light of the control box switch button goes out.
- (3) Turn off the red main power switch on the back panel of the control box.



### WARNING

To turn off the robot, you must strictly follow the above steps, otherwise it may cause damage to the robot's file system and malfunction of the robot.

## 2.10 Capsule Control

The capsule control area is only displayed when it is not on the home page, the upper part of the capsule is the **ROBOT**, and the lower part of the capsule is the **TASK**. Long press the capsule body to drag to adjust the position of the capsule control area on the page.

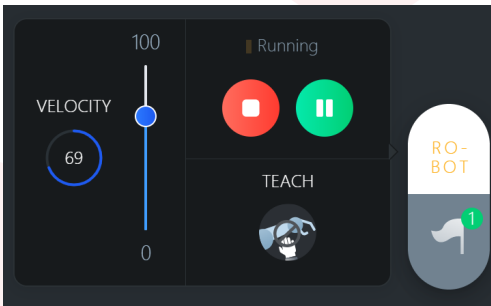

**Figure 2.18** Capsule Control

**ROBOT** Contains the current state of the robot, the robot start/stop button, the teach button, and the speed adjustment lever. The robot can be operated and controlled when it is not on the homepage.

**TASK** Contains a list of running and completed tasks and the pause/resume and stop buttons of the task. You can view the task history when it is not on the home page. For specific operations, see [2.5.6 Task History \(page 34\)](#).



# Chapter 3

## Robot Using

---

Before describing how to create and edit a scene, let us first get familiar with the scene editor of Lebai Robot and learn how to drag-and-drop teach<sup>1</sup> operation.

### 3.1 Scene Editor

You can program the robot in the scene editor, i.e., edit the scene.

#### 3.1.1 Editor Type

The scene module provides two types of editors:

---

<sup>1</sup>Drag-and-drop teaching: The robot is dragged and driven by human hands. At the same time, the robot can reach a selfbalanced running state under the condition of correctly setting the mass and center of mass of the end tool.

**Timeline Editor** A scene editor that is visualized, easy to use, and does not require a user to understand any logical relationships. This editor is suitable for beginners, since a user only need to add corresponding blocks<sup>2</sup> in the timeline editor as needed to operate the robot (See [Figure 3.1](#)).

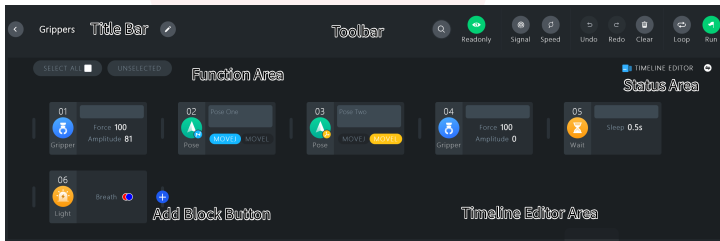

**Figure 3.1** Timeline editor

<sup>2</sup>In the timeline editor, each operable independent element is called a *block*, and a collection of several action blocks can be packaged into a package.

**Code Editor** A scene editor that is designed based on Lua language and supports complex operations. A scene editor that is designed based on Lua language and supports complex operations. It is suitable for users with a certain programming foundation and logical thinking. You can write codes to operate the robot (See [Figure 3.2](#)).

```

1 -- name: Grippers.rob
2 -- author: labo2
3 -- version: 1.0
4 C_POSE = {}
5 J_POSE = {}
6 set_claw(100, 0)
7
8 C_POSE["pose_one"] = {-0.20484817224824531, 0.83171922185040669, 0.51199835621943339, -0.3345388249547623, 1.4799682868316278, -2.841579815978311}
9 J_POSE["pose_one"] = {j1 = -0.601683383324121, j2 = -1.8695398862356263, j3 = 1.325194352702988, j4 = 0.6271165288470986, j5 = 1.8684821211818996, j6 = -1.8982162333783253}
10 move(C_POSE["pose_one"], 0.05, 2, 0.05, 0, 2)
11 -- pose_two
12 C_POSE["pose_two"] = {-0.20484817224824531, 0.83171922185040669, 0.51199835621943339, -0.3345388249547623, 1.4799682868316278, -2.841579815978311}
13 J_POSE["pose_two"] = {j1 = -0.601683383324121, j2 = -1.8695398862356263, j3 = 1.325194352702988, j4 = 0.6271165288470986, j5 = 1.8684821211818996, j6 = -1.8982162333783253}
14 move(C_POSE["pose_two"], 1.45, 0, 0.05, 0, 2)
15 set_claw(100, 0)
16 exit()
17 set_led(1, 2, {0, 2, 0, 2})
18

```

**Figure 3.2** Code Editor



### 3.1.2 Switch Editor Type

The code editor is only available in the Expert Mode. The steps to switch from the Timeline Editor to the Code Editor are as follows:

- (1) Enter **SETTINGS**, click **OPERATION MODE**, or click the  button on the right side of the **Timeline Editor** in the status area to enter the operation mode selection page, select **Expert Mode** and click the **SAVE** button in the upper right corner of the operation mode page.
- (2) Return to the previous scene that was being edited.
- (3) In the Timeline Editor, move the mouse to the **Timeline Editor** button, and select **Code Editor** in the popup menu to switch between the two editors.

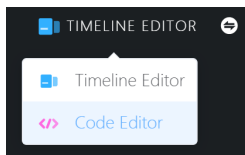

**Figure 3.3** Switch Editor Type



#### NOTICE

When the editor of a scene is switched from the Timeline Editor to the Code Editor, it cannot be reversed back. Please **EXPORT**<sup>a</sup> or **COPY** the scene you need to make a backup before operation.

<sup>a</sup>See [3.3.5 Export Scene \(page 68\)](#).

## 3.2 Drag-and-Drop Teaching

It is necessary to understand the drag-and-drop teaching method of Lebai robot before learning how to add pose blocks. There are two operation methods for drag-and-drop teaching for you to choose from:

- Click the teaching icon  in L Master<sup>®</sup> to enable the teaching mode for the robot, drag the robot to the specified position, and click the teaching icon again to exit the teaching mode.
- Long press the robot's end convex button<sup>3</sup> to enable the teaching mode for the robot. After dragging the robot to the certain position, release the robot's end convex button to exit the teaching mode.



### WARNING

Before use the drag-and-drop teaching, please make sure to set the mass and CoG of the end device<sup>a</sup> correctly. Incorrect settings may result in accidental injury.<sup>b</sup>

<sup>a</sup>See [3.5.1 End Device \(page 72\)](#).

<sup>b</sup>See [3.6.2.2 Operational Safety \(page 75\)](#).



### WARNING

In the teaching process, the rotation of joint angle should not exceed the safe range<sup>a</sup>, otherwise it may cause the robot to stop suddenly or result in other faults.

<sup>a</sup>See [3.6.2.2 Operational Safety \(page 75\)](#).

<sup>3</sup>See [3.4.2 Hardware button \(page 70\)](#).

## 3.3 Scene Programming

### 3.3.1 Create A New Scene

Click the **SCENE** button on the home page of L Master<sup>®</sup> to enter the **SCENE LIST**, click the **ADD SCENE** button on the right side of the toolbar on the page, and enter the scene name to complete the creation of a new scene.

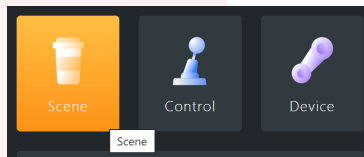

**Figure 3.4** Scene entrance

### 3.3.2 Add A Block

The Timeline Editor supports the following block types:

- Position
- Gripper (Claw)
- Wait
- Notification
- Digital I/O
- Analog I/O
- Semaphore
- Payload

Click the Add Block button  in the Timeline Editor to pop up the **Choose block type**, as shown in [Figure 3.5](#).

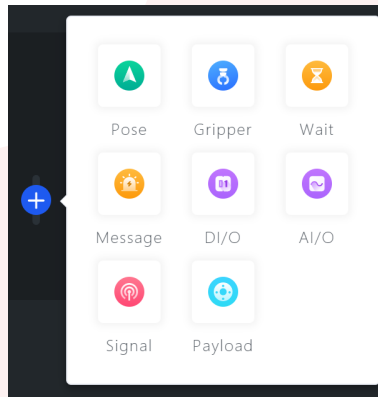

**Figure 3.5** Choose block type

The following chapters describe the usage of different block types in turn.

### 3.3.2.1 Pose Block

Position<sup>4</sup> is the core control module in robot control. In the Timeline Editor, you only need to add the pose blocks according to the following tutorial to make the robot move according to the predetermined pose and action.

---

<sup>4</sup>The “position” mentioned in *this manual* consists of robot pose and posture data. In the subsequent content of this document, unless “pose and posture” is explicitly mentioned, all “positions” refer to the pose and posture of the robot.

## Add position

There are two ways to add a pose in the Timeline Editor for you to choose from:

- Add Block button  in the editing area of the Timeline Editor, select the **Position**, enter the pose name in the open **Dialog of add position** (as shown in [Figure 3.6](#)), and click the button to save the current pose of the robot in a new pose block<sup>5</sup>.
- Doubleclick the convex button at the end of the robot, and the system will save the current pose of the robot in a new pose block.

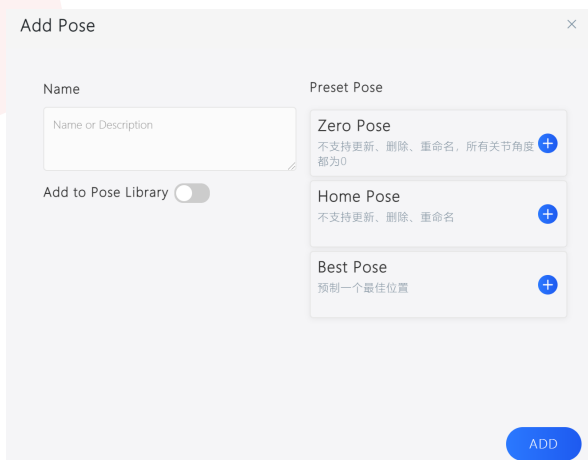

**Figure 3.6** Dialog of add position

<sup>5</sup>The “block” refers to the smallest visual editing module in the Timeline Editor. A “module” represents a type of actions which includes pose and I/O.

By combining the drag-and-drop teaching and the above method of adding pose blocks, you can add the desired pose blocks according to your needs (as many as you want) until the scene editing is complete.

### Edit position

As shown in [Figure 3.7](#), place the cursor on the pose block to make the current pose block in focus.

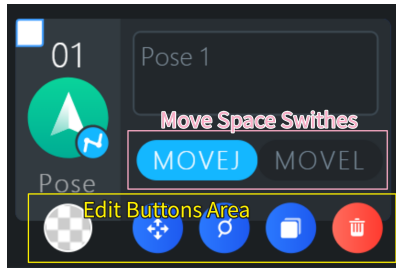

**Figure 3.7** The focal state of the pose block

The two buttons in the trajectory type switching area are used to switch between joint space movement (movej) and Cartesian space linear movement (movel).

- ⊕ Represents the movement in joint space<sup>6</sup>.
- ⊖ Represents the linear motion in Cartesian space<sup>7</sup>.

The buttons in the edit operation button area are:

**Style:** The background color of the block can be changed<sup>8</sup>.

- ⊕ **Fine-tuning:** Finetune and update the location data stored in the current location block.

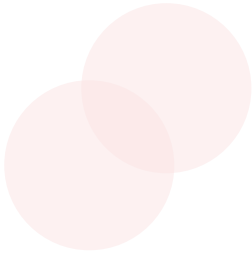



---

<sup>6</sup>Joint space: the robot motion space described with the angle of each joint of the robot.

<sup>7</sup>Cartesian space: The full name is Cartesian coordinate system space, which is the rectangular coordinate system space we commonly use.



<sup>8</sup>The color of the Style button is consistent with the background color of the block. When a block is selected, the block will be highlighted with this color as the background. In particular, the style is transparent by default, and the highlighted background color selected by the block is blue. The Style, Copy, and Delete buttons are common buttons in the block operation button area.

-  **Speed and Acceleration Time:** Adjust the speed and acceleration time of the pose block<sup>9</sup>.
-  **Copy:** Copy a current block.
-  **Delete:** Delete the current block.

## Fine-tuning

When editing a scene, the pose in the motion track needs to be fine-tuned precisely by applying fine-tuning to individual positions. Select the Finetuning icon, and the page will automatically jump to the finetuning page.

When the current **ACTUAL POSITION** of the robot is inconsistent with the **TARGET POSITION** stored in the pose block, a blur robot icon and a solid robot icon will appear in the finetuning page. The blur one represents the target pose stored in the current pose block, and the solid one represents the current actual pose of the robot.

You can switch between the actual pose  and the target pose  using switch button to view the values of the target pose and the actual position.

## Coordinate space fine-tuning

Different coordinate system representation methods can be selected during finetuning:

---

<sup>9</sup>The acceleration time is inversely proportional to the acceleration. The greater the acceleration, the shorter the acceleration time; while the shorter the acceleration time, the longer the acceleration time.



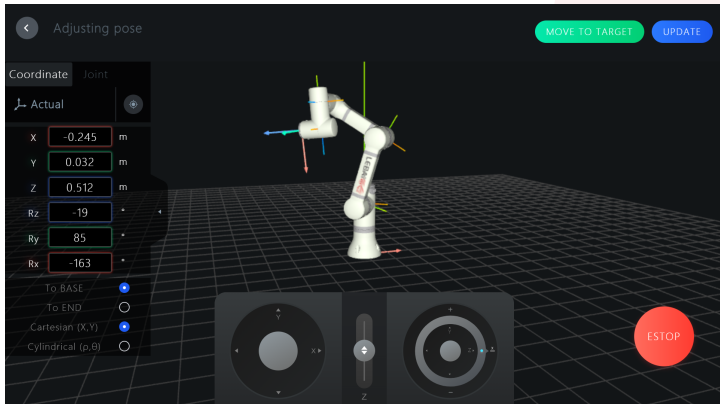

**Figure 3.8** Coordinate space fine-tuning

- When “relative to the Base”, the rectangular coordinate system or cylindrical coordinate system can be used.
- When “relative to the End”, only Cartesian coordinate system is supported.

When the reference coordinate system is **To BASE**, it means that the center of the robot base is taken as the origin of the coordinate system.

By selecting the Cartesian coordinate system as the adjustment method, and entering the pose  $(X, Y, Z)$  or posture  $(R_z, R_y, R_x)$ <sup>10</sup> value in the pose information display box on the finetuning page, the robot will automatically move to the pose you choose. You can also operate the robot by pulling the levers in all directions at the bottom of the screen. When the lever is released, the fine adjustment stops.

<sup>10</sup>The posture of Lebai robot in Cartesian space (Cartesian coordinate system) adopts EulerZYX notation, please refer to related robot basic books or tutorials. The posture  $(R_z, R_y, R_x)$  can also be described as  $(\alpha, \beta, \gamma)$ .

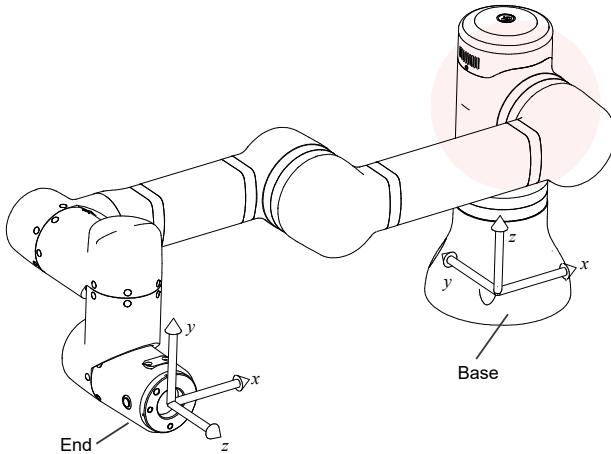

**Figure 3.9** Coordinate to the base or the end

Click the **UPDATE** button to complete the fine adjustment.

Lebai robot uses  $Z$ - $Y$ - $X$  Euler angle (EulerZYX) to describe the posture of the end of the robot, that is, first rotate the  $R_z$  angle around the  $Z$  axis of the coordinate system, then rotate the  $R_y$  angle around the  $Y$  axis of the rotated coordinate system, and finally rotate around the  $X$  axis of the coordinate system by the  $R_x$  angle twice.

Select the cylindrical coordinate system<sup>11</sup>, the left adjustment dial will change from adjustment  $(X, Y)$  to adjustment  $(\rho, \theta)$ .

When the reference coordinate system is selected as **To END**

<sup>11</sup>The  $XY$  plane of the cylindrical coordinate system is the polar coordinate system. The point  $P(x, y, z)$  in the rectangular coordinate system is represented as  $P'(\rho, \theta, z)$  in the cylindrical coordinate system, where  $\rho = \sqrt{x^2 + y^2}$ ,  $\theta = \arctan \frac{y}{x}$ .

(without adding TCP<sup>12</sup>), the center of the robot flange is used as the origin of the coordinate system, and the rectangular coordinate system is used as the adjustment method. Enter the pose or posture on the fine adjustment page or set the value or pull the lever at the bottom of the screen. After the robot automatically moves to the specified position, click **UPDATE** to complete the fine adjustment of the position.

### Joint space fine-tuning

Click on the **Joint Space** at the top left of the finetuning page, and enter the angle value of joint 1 to joint 6, then the robot will automatically reach the specified position. Or pull the levers in all directions at the bottom of the screen to operate the robot. When the lever is released, finetuning stops. Click **UPDATE** to complete Fine adjustment of position.

### Speed and acceleration time

Speed and acceleration time are modified for the current scene or the speed ( $v$ ) and acceleration ( $a$ ) of a single location block. The horizontal axis corresponds to the acceleration time. The vertical axis corresponds to the speed. The closer the vertical axis is to the origin, the lower the speed.



To adjust the speed and acceleration time, the user can do it globally<sup>13</sup> on the toolbar of the scene editor<sup>13</sup>, or individually for each pose block.

<sup>12</sup>See [3.6.1 TCP Settings \(page 72\)](#).

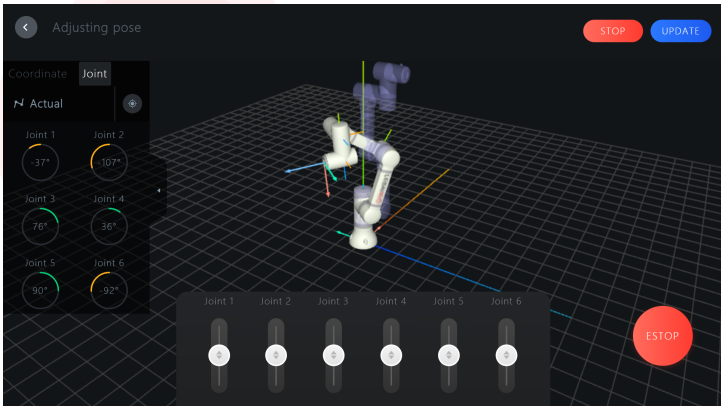
<sup>13</sup>See [3.3.3.4 Speed and Acceleration Time \(page 60\)](#).



**Figure 3.10** Joint space fine-tuning

Click the pose block  button to pop up the **Speed and acceleration time control**. The icon  in the upper right corner is the synchronization lock between the current pose block and the information about global speed and acceleration time on the editor toolbar. When a new pose is added to the scene, the global lock of the speed and acceleration time control of the pose block is locked by default, which means it is consistent with the global speed and acceleration time of the current scene. When the user drags a drag point to adjust the horizontal or vertical axis of the control and changes the speed and acceleration time, the global lock will be unlocked, that is, the pose block uses the speed and acceleration time specified by yourself and no longer uses the global speed and acceleration time parameter values. You can click the icon  again to lock Synchronization lock, then the pose block will keep the parameter value consistent with the global speed and acceleration time.

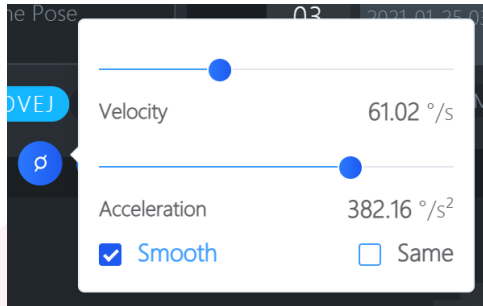

**Figure 3.11** Speed and acceleration time control

The smooth function mainly refers to that the robot control system automatically optimizes the best path and passes through the target pose of the current pose block without stopping, making the action continuity better and the moving time shorter when there are multiple adjacent pose blocks. higher efficiency. When the smoothing function is turned on, there will be no obvious slowdown and stop when the robot moves between the two blocks.

After adding pose blocks, if you don't need to add other types of blocks, you can move to [3.3.3.8 Start A Scene \(page 61\)](#).

### 3.3.2.2 Gripper Block

Select **Gripper** in the **Choose block type**, and the **Dialog of adding gripper block** will pop up (See [Figure 3.12](#)). Enter a description of the Gripper action and set the strength and amplitude. If you need to preview the opening and closing effect of the Gripper, please turn on the **Preview** switch (realtime preview) or click the **PREVIEW** button (manual preview). After confirming the effect is correct, click

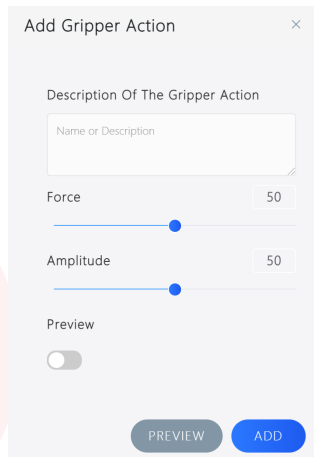

**Figure 3.12** Dialog of adding gripper block

ADD

### 3.3.2.3 Wait Block

Select **Wait** in the **Choose block type** enter the number of seconds to wait.

### 3.3.2.4 Notification Block

Select **Notification** in the **Choose block type**. Notifications are divided into light board prompts and popup prompts. The light board prompts are as follows:

**Off** The light board turns off the display;

**Always on** The light board keeps the specified color always on;

**Breathing** The light board breathes in the specified color;

**Evenly rotating** The light board displays in evenly distributed rotation between 2 or 4 designated different colors;

**Rotate with the same color** The light board displays rotating in a certain color;

**Flashing** The light board flashes in a certain color.

### 3.3.2.5 Digital I/O Block

Select **Digital I/O** in the **Choose block type**. In the popup Add dialog box, the top tab corresponds to the operation type of the digital I/O. The digital I/O block supports three types of operations:

**Read** Read the input value of a digital I/O port;

**Wait** When the block is executed, it will stay and wait for the value of a certain digital I/O to become the selected value;

**Set** Set the output value of a certain digital I/O port.

There are three types of digital I/O ports: control box I/O, flange I/O and external I/O (if any).

Click **ADD** to complete the insertion of a simulated I/O block.



#### NOTICE

Before running the task, make sure that the input and output electrical connections of the digital I/O are operational.

### 3.3.2.6 Analog I/O Block

Select **Analog I/O** in the **Choose block type**. In the popup Add dialog box, the top tab corresponds to the operation type of the analog I/O. The analog I/O block supports three types of operations:

**Read** Read the input value of a analog I/O port;

**Wait** When the block is executed, it will stay and wait for the judgment condition of a certain analog I/O value matching the selected value;

**Set** Set the output value of an analog I/O port.

There are only two types of analog I/O ports: control box I/O and external I/O (if any). The flange has no analog I/O ports.

Click to **ADD** complete the insertion of a simulated I/O block.



#### NOTICE

Before running the task, make sure that the input and output electrical connections of the analog I/O are operational.

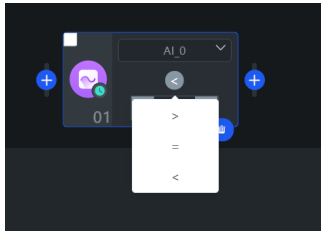

**Figure 3.13** Analog I/O judgment conditions

Under the waiting operation type, there are three judgment conditions:  $>$ ,  $=$ , and  $<$ . Click the waiting condition button of a waiting



analog I/O block (as shown in [Figure 3.13](#)) to edit the corresponding judgment conditions.

### 3.3.2.7 Payload Block

Select **Payload** in the **Choose block type**, and enter the load mass or CoG that needs to be modified in the Add Payload dialog box. This function is used to edit the mass and CoG of the load at runtime.



#### **WARNING**

When the robot is installed with a end-effector, and the end-effector has functions such as picking and placing items, it is necessary to insert an block corresponding to the change in mass and CoG in the end load after picking and placing in the corresponding pose of the Timeline Editor. If not set normally, there might be reduction in the life of the corresponding parts of the robot, and false alarms in collision detection might result.



#### **WARNING**

When adding a Payload configuration, the mass and CoG settings must be as consistent as the end-effector quality. If you need to replace or remove the end-effector, you must edit the load parameters or disable the corresponding end device accordingly, otherwise accidental injury might result.

### 3.3.3 Toolbar

The toolbar of the Timeline Editor can provide functions such as searching, editing, operation and execution for the scene.



Figure 3.14 Timeline editor toolbar

#### 3.3.3.1 Change the Scene Name

Click the Edit button  behind the title text of the toolbar to edit the scene name in the popup Scene modification dialog box.

#### 3.3.3.2 Search

Click the Search button to expand the block search box.

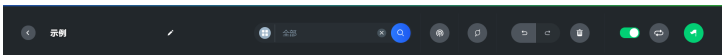



Figure 3.15 Expanded block search box

In the expanded state of the search box, click the icon  on the left side of the search box to search based on the block type in the popup box quickly. At the same time, you can also use the keywords entered in the text input box to search for the blocks of the corresponding type or all types that match the keyword.



### 3.3.3.3 Semaphore

The semaphore is temporarily not available in L Master<sup>®</sup> v2.1.

### 3.3.3.4 Speed and Acceleration Time

The Speed and acceleration time on the toolbar are the configuration entries for the global speed and acceleration time of the current scene. When the speed and acceleration time adjustment operations of a single pose block mentioned in [3.3.2.1 Edit position \(page 47\)](#) are not applicable, all pose blocks in this scene use the global configuration of speed and acceleration time.

### 3.3.3.5 Undo/Redo

When you deleted an block by mistake or performed a wrong operation, you can click the undo button  to perform the undo operation. Conversely, if you want to restore the previously undone operation, you can click the redo button  to perform the restore operation.



#### WARNING

When returning or exiting from the current editor page, the undo and redo history of the editor will be cleared. When you return to the current scene editor again, the previous undo and redo operations cannot be performed.

### 3.3.3.6 Delete/Clear

When you select some blocks in the editing area, the number of blocks will be displayed on the delete/clear button . You may

click this button to delete the blocks. When no block is selected in the editing area, you may click this button to clear the current scene.



### WARNING

Make sure that you know the consequences of doing this and understand that this action is done after you have confirmed the deletion or cleanup for the second time. If you exited the current editor after performing the deletion or cleanup and reenter the scene to edit it, you will not be able to restore the status before deletion or cleanup.

#### 3.3.3.7 Scene Loop Cycles

Click the cycle number icon  in the upper right corner of the Timeline Editor toolbar to edit the cycle number of the task (the default cycle number is 1). When the number is 0, it means the task will be executed for infinite  $\infty$  cycles until the robot e-stops or shuts down.

#### 3.3.3.8 Start A Scene

There are two ways to run the scene for you to choose from:

- Click the run task icon  in the upper right corner of the toolbar.
- Doubleclick the shoulder button of the robot, as shown in [Figure 3.16](#) (the button with the logo “白” in the middle of the shoulder light board)

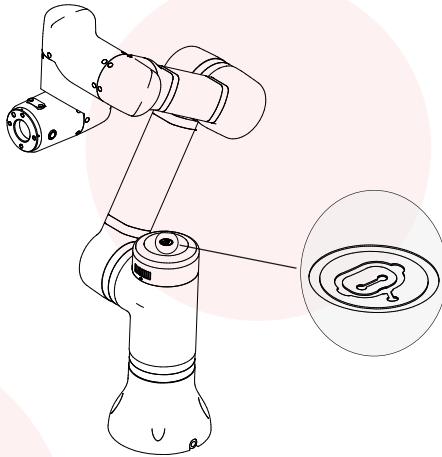

**Figure 3.16** Shoulder button

### 3.3.3.9 Robot Pose Safety Inspection

When the current pose of the robot is the same as the first pose to be run<sup>14</sup> in the scene, the scene runs without performing pose safety check. When the current pose of the robot is inconsistent with the first pose to be run in the scene, before running the scene, a pose safety check will be performed and the **Restore pose window** will pop up.

In the Pose safety check window, there are two ways to move the

---

<sup>14</sup>The first pose to be run: The chronologically first pose type action block in the set of action block that meets the conditions in the Timeline Editor (when no action block is selected, it refers to all the action blocks in the editor; when some action blocks are manually selected, it refers to these selected action blocks). This action block represents the first pose to be run. The robot control system will check the pose of the action block and compare it with the current pose of the robot.

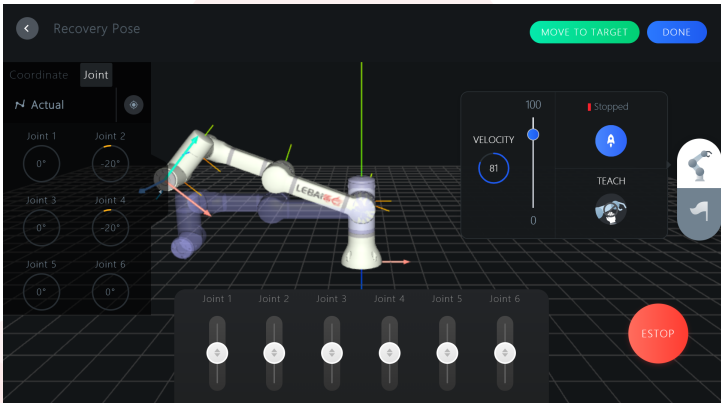

**Figure 3.17** Restore pose window

robot to the first pose to be run in the scene:

- Click the Pose safety check window to **MOVE TO TARGET** and wait for the robot to move to the first pose to be run in the scene. You can click **STOP** at any time to stop the movement while moving.
- Long press the robot end flat button and release it after the robot moves to the first pose to be run in the task.

Click the **DONE** button in the upper right corner, and the scene starts to run. When the scene is running, long press the shoulder button to pause or resume a task.



### NOTICE

When the current pose of the robot is different from the first pose to be executed in the scene to be executed, pose safety check will be performed before the scene is executed.



## WARNING

After using the flat end button to move the robot to the first pose to be run, please keep a safe distance from the robot and click the **DONE** button to run the scene, otherwise accidental injury might result.

### 3.3.4 Operation Skills

#### 3.3.4.1 Quick Search Block

Rightclick a block and select **Find Similar Blocks** from the popup rightclick menu to perform a quick search for blocks of the same block type and containing the currently selected block title as a keyword.

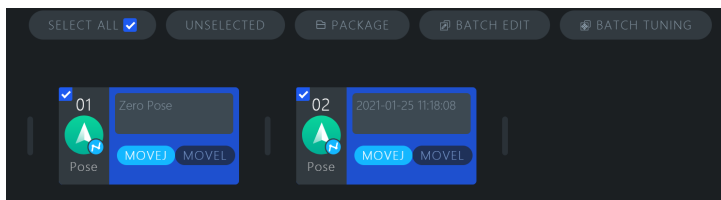

#### 3.3.4.2 Batch Edit Blocks



**Figure 3.18** Batch Edit Blocks

Click the **BATCH EDIT** button in the functional area of the scene editor, or rightclick the block and select **Batch Edit** to edit the following contents of the block in batches.

- Pose Block** You can uniformly edit the pose name, switch between joint space movement (movej) and Cartesian space linear movement (movel), speed and acceleration time, and enable and disable smoothing functions. After confirming the batch modification, the data of every individual pose block will be updated with the pose data of the robot in the current state.
- Gripper Block** The description, strength and amplitude of the Gripper action can be modified.
- Waiting Block** The number of seconds to wait and the description of the purpose/function of the wait can be modified.
- Notification Block** The light board prompt and popup prompt are different subtypes of blocks, and different subtypes of blocks cannot be modified in batches.
- Digital I/O Block** Support batch modification of reading, waiting and setting.
- Analog I/O Block** Support batch modification of reading, waiting and setting.
- Payload Block** Support batch modification of load quality or CoG of blocks of the same subtype.

Click the  button in the lower right corner of the dialog box to perform batch editing operation. You can click the  button in the upper right corner to cancel the operation.





## NOTICE

For batch editing of blocks, the block type and subtype (if there are subtypes for this type of blocks) must be consistent.

### 3.3.4.3 Batch Fine-Tuning of Pose Blocks

Select 2 or more pose blocks, and click the **BATCH TUNING** in the functional area of the Timeline Editor or place the cursor on the selected pose block so that the current pose block is in focus, then rightclick and select **Batch fine adjustment position** in the pop-up menu to enter the **Adjustment position** page<sup>15</sup>.

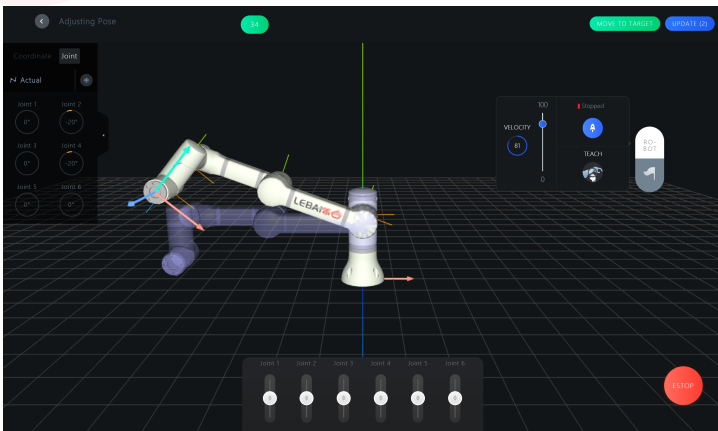

**Figure 3.19** Batch Fine-Tuning of Pose Blocks

<sup>15</sup>See [3.3.2.1 Fine-tuning \(page 49\)](#).

After the finetuning to the target position, you can click the **UPDATE** button in the upper right corner of the page to complete the batch finetuning or click **CANCEL** to abandon the batch finetuning operation. The number on the right side of the **UPDATE** button indicates the total number of currently selected location blocks.

### 3.3.5 Export Scene

Select the scene to be saved on the scene list page, and move the mouse to the  button in the upper right corner of the scene card to pop up the scene menu. Select **Export**, then choose a save location of the scene file in the popup save dialog box (the file extension is 1bd).

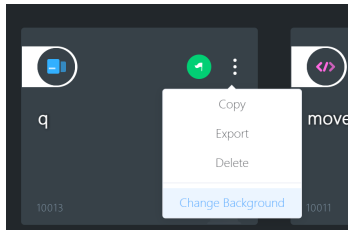

**Figure 3.20** Export Scene

### 3.3.6 Import Scene

As shown in [Figure 3.21](#), in the toolbar of the **scene list**, click  icon to open the scene file you exported. After the import is complete, the scene will be introduced automatically.

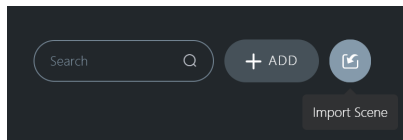

**Figure 3.21** Import Scene

## 3.4 Control

The control module is mainly divided into:

- Virtual Control
- Pose Library
- I/O Control
- Gripper Control
- Hardware Button
- LED Control

### 3.4.1 Virtual Control

The current pose of the robot can be adjusted through virtual control.

Refer to the introduction of finetuning function in

[3.3.2.1 Fine-tuning \(page 49\)](#) for specific operation methods.

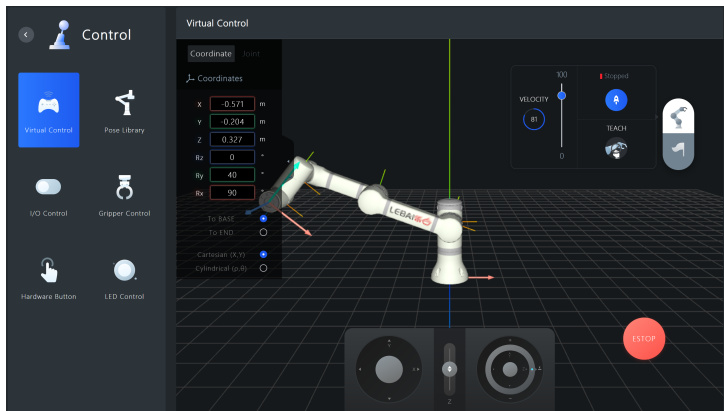
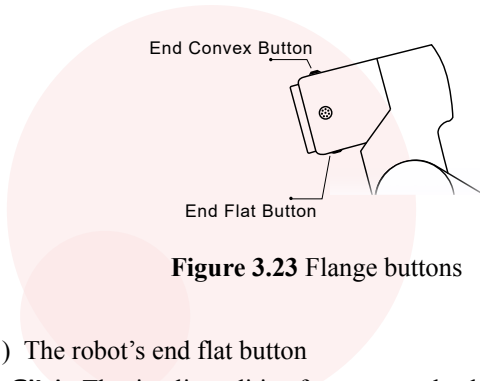

Figure 3.22 Virtual control

## 3.4.2 Hardware button



**Figure 3.23** Flange buttons

(1) The robot's end flat button

**Click** The timeline editing focus moves backward by one block;

**Double-click** The timeline editing focus moves forward by one block;

**Long press** If you are currently at the pose block's Refresh pose popup box (click the finetuning button of the pose block to enter) or the pose library's Apply pose popup box, move to the target position;

**Release** When moving to the target pose after a long press, release the button will stop the current movement.

(2) The robot's end convex button

**Long press** Enter the teaching mode;

**Release** Exit the teaching mode;

**Double click** Add a pose block/code in the editor;

**Click** Only if that the current block is a pose block, when the current pose block is not in the fine adjustment pose dialog box, click this button to enter the fine adjustment current pose dialog box. If the current pose block is al-

ready in the fine adjustment pose dialog box, you can click this button to update the pose data saved in the current block.

### (3) Shoulder button

**Long press** Switch between queue pause and resume, i.e., pause when **RUNNING** or resume when **PAUSED**;

**Click** When there is a popup or other secondary interface in the scene editor, cancel the operation (button, dialog box, etc.);

**Double-click** If you are currently in the scene editor interface and there is no other popup box, switch between run and stop operation; otherwise, confirm the operation (button, dialog box, etc.).

### (4) Button combo

**Start/stop** Long press the flat button at the end of the robot then press the shoulder button at the same time to switch between starting and stopping the robot.



#### NOTICE

The button combo for starting/stopping the robot is only available when the robot is not in emergency stop state or not powered off.

## 3.5 Device

### 3.5.1 End Device

If you need to add a effector (such as a gripper) at the end of the robot, first click **DEVICE**; then click **ADD** on the end device to set the mass and CoG of the corresponding auxiliary tool; and finally, click **Enable**. If you need to remove the end effector, click **Disable**.



#### WARNING

- The mass and CoG should be as consistent as possible with the mass and CoG of the end effector added.
- When replacing or removing the end effector, be sure to edit the mass and CoG of the end device accordingly or close the corresponding end device, otherwise accidental injury might result.

## 3.6 Settings

### 3.6.1 TCP Settings

The full name of TCP is Tool Center Point, which means the center point of the robot tool. You can use the TCP setting page to set the offset/conversion amount of the TCP pose and posture of the robot end. The system does not set TCP by default. When the an end effector is installed on the robot, you may choose to add TCP settings according to the scene application.

TCP can be added by teaching. Click the **ADD** button, the **Teaching Add** in the menu, open the **Add TCP settings by teaching** to add TCP settings, as shown in [Figure 3.24](#). Now you can click the Teaching icon and drag-and-drop teach the robot to confirm the four key points one by one in four different postures while the end effector of the robot touches the same control point (that is, keeps the end effector always in contact with the same position). The robot can automatically recognize the TCP pose information according to the different positions and directions of the end flange. The posture information does not support “add by teaching” currently, thus need to be filled out manually.

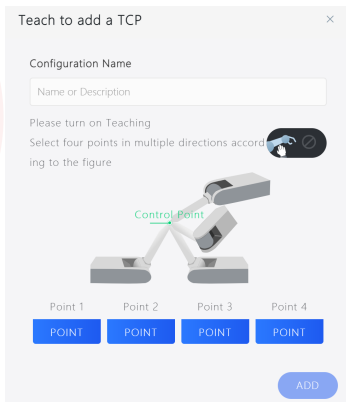

**Figure 3.24** Add TCP settings by teaching

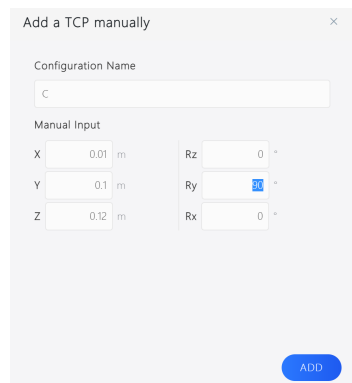

**Figure 3.25** Edit TCP settings

As shown in [Figure 3.25](#), the user can also **Add** or **EDIT** to enter the **Edit TCP settings** settings and set the pose and posture



of the end effector manually.

## 3.6.2 Safe Settings

### 3.6.2.1 Collision detection

The default state of the robot collision detection is **Emergency Stop** after the installation guide is opened. While operating, the robot's actions after detecting a collision with external resistance are divided into two types: **Pause** and **Emergency Stop**. You can adjust the detection sensitivity by yourself.

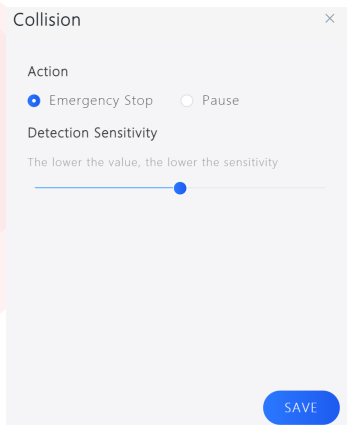

(a) Emergency Stop

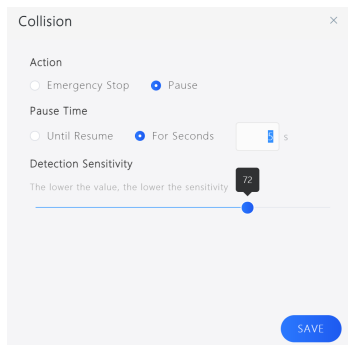

(b) Pause

**Figure 3.26** Collision detection

Action after collision:

**Emergency Stop** In this case, the robot needs to be restarted and taught to a safe pose before continuing the operation.

**Pause** If you select a custom number of seconds, the task will automatically resume when the specified pause time is reached; if you select permanent pause, you need to click the Resume task button  in the task history list column on the homepage.

### 3.6.2.2 Operational Safety

In operational safety, you can view and adjust the following runtime parameters:

- Maximum and minimum angle of each joint
- Joint space operation configuration
- Coordinate space running configuration



#### **NOTICE**

Editing the running configuration of the robot's joint space will affect the robot's speed limit. When the running speed of any joint exceeds the maximum speed limit, the robot will emergency stop automatically.



#### **DANGER**

Editing the running configuration of the robot joint space and editing the running configuration of the coordinate space will affect the speed and acceleration time (acceleration) of the pose block in the scene editor proportionally.

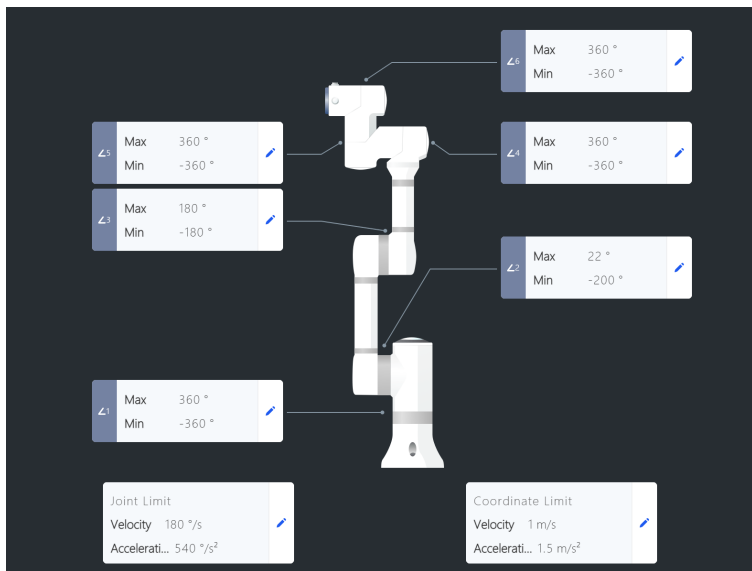

**Figure 3.27** Operation safety settings

### 3.6.3 Operation mode

There are two operating modes as follows for you to choose according to your own situation:

#### Normal Mode

In the beginner mode you can use the easy-to-use Timeline Editor. Some functions of the expert mode will be hidden in the beginner mode to save you the trouble brought by complex and advanced functions.

## Expert Mode

In expert mode:

- You can switch to Code Editor which uses Lua as the programming language.
- You can convert scenes in the Timeline Editor into Lua codes.
- You can close the pose safety check in the Timeline Editor mode.
- Supports installation settings and can customize the configuration of any install direction.



### NOTICE

Before closing the safety check, please make sure that you are well aware of the danger of the operation.

To switch between operation modes:

- Enter the **SETTING** page, perform switchovers in the **OPERATION MODE** and save the operation.
- Click the switch icon in the upper right corner of the scene editing page to switch and save the operation mode.

### 3.6.4 System update

Enter the **SETTINGS**, on the **SYSTEM UPDATE** page, if the current system is up to date, the icon in the center of the screen will be blue, as shown in [Figure 3.28](#). Click **CHECK SYSTEM**, the circular pattern in the center of the screen shows **Checking for Updates**.

When an available update of the system is detected, the icon in the center of the screen turns orange and displays “System update

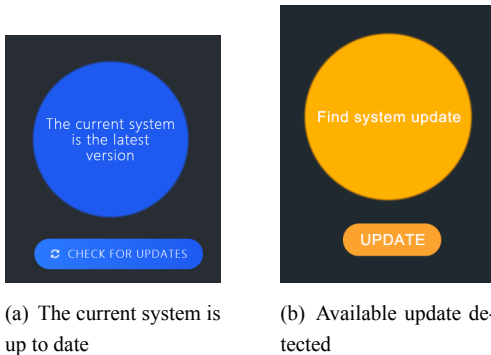

**Figure 3.28** System update

detected” with latest version number found. Click **UPDATE** below, and the system will automatically update to the latest version.



**NOTICE**

- Please make sure that the robot status is **STOPPED** before updating the system.
- During system update, no other operations are allowed, otherwise serious consequences such as damage to the robot system may result.

## Chapter 4

# Software Resetting

---

When the robot is abnormal and cannot be recovered by adjusting the program or restarting, look for the small round hole marked RESET on the back panel of the control box, and use the SIM card removal pin of a mobile phone or a straightened paper clip to press and hold for 20 seconds until the power button indicator on the top of the control box flashes blue. Then you may let go and wait patiently until the button indicator light is steady blue. When the light of the button on the shoulder of the robot lights up, the robot is successfully reset.



### **WARNING**

Caution! This operation will clear all the data saved in L Master<sup>®</sup>. Before performing this operation, please make sure that you have backed up all necessary data.

# Chapter 5

## Maintenance and Repair

---

Maintenance work must follow all safety instructions in *this manual* strictly.

Maintenance, calibration, and repair work must be performed in accordance with the latest *Service Guide*, which can be viewed on Lebai's official website: <https://i.lebai.ltd/d/s/>.



### NOTICE

- Keep the product clean (the robot should be cleaned every day).
- Check for loose fasteners every three months.

Repairs must be performed by authorized service providers or professional technicians designated by the company. It is necessary to ensure the required safety level for maintenance and repair work, comply with applicable national or regional work safety regulations, and check whether all safety functions work normally.

The purpose of maintenance work is to ensure the normal operation of the system, or to help it recover when the system fails. Maintenance includes fault diagnosis and actual maintenance. Maintenance includes fault diagnosis and actual maintenance.

The following safety procedures and warnings must be followed when operating the robot or control box:



- It is necessary to take necessary precautions during maintenance to prevent others from reconnecting the power to the system during maintenance. After power off, check the system again to make sure it is indeed powered off.
- Check the ground connection of the power plug before restarting the system.
- It is strictly prohibited for users to disassemble the robot or control box solely by themselves.
- Lebai-designated service providers or professional technicians must comply with ESD (electrostatic discharge) regulations during maintenance work.
- Prevent water or dust from entering the robot or control box.
- It is forbidden to change any information in the software security configuration. If the safety parameters change, the entire robot system should be regarded as a new one, which means that all safety audit processes, such as risk assessment, must be updated.
- Replace faulty parts with new parts with the same part number or equivalent parts approved by our company.
- Reactivate all disabled safety measures immediately after completion of the work.
- Record all maintenance operations and save them in the technical documents relevant to the entire robot system.
- The control box has no parts that can be repaired solely by the end user. If maintenance or repair service is required, please contact your dealer or our company.





# Chapter 6

## Service and Support

---

### 6.1 Product Warranty

Without prejudice to any claim the user (customer) may have in relation to the dealer or retailer, the user (customer) shall be granted a manufacturer's warranty under the conditions set out below:

Within 12 months from the date of delivery of the equipment and its components to the customer (Not exceeding 15 months from shipment), *our company* shall provide necessary spare parts for defects caused by poor manufacturing and/or materials, and the user (customer) shall provide working hours to replace or repair related parts under the guidance of *our company's* professional technicians.

If the equipment defect is caused by improper handling by the user (customer) and/or failure to follow the relevant information described in *this manual*, *our company* shall not be liable for product quality assurance. This *Product Warranty* shall not apply to or does not extend to maintenance (such as installation, configuration, and software downloads) performed by authorized dealers or users (customers) themselves. The user (customer) must provide purchase receipt, together with the date of purchase as evidence for invoking *Product Warranty*. Ownership of equipment or components replaced by or returned to *our company* shall vest in *our company*.

Any other claims resulting out of or in connection with the equipment are not included in the scope of this *Product Warranty*. No clause in this *Product Warranty* attempts to limit or exclude the statutory rights of users (customers), or the manufacturer's liability for personal injury or death caused by its negligence. The duration of this *Product Warranty* shall not be extended by services rendered under the terms of this *Product Warranty*. Insofar as no warranty default exists in this *Product Warranty*, *our company* reserves the right to charge users (customers) for replacement or maintenance. The above provisions do not imply a change in the burden of proof to the detriment of users (customers).

## 6.2 Disclaimer

This Warranty will be invalid if the equipment defect is caused by improper handling or failure to follow the relevant information described in the user manual, including but not limited to production loss or damage to other production equipment.

Our company is committed to continuously improving the reliability and performance of the products, and therefore reserves the right to upgrade the products. The information contained in *this manual* is subject to change without notice.

Our company strives to ensure the accuracy and reliability of the contents of *this manual*, but is not responsible for any accidents and injuries caused by any errors or omissions. In particular, failures caused by the following conditions are not covered by this warranty:

- (1) Failure to follow the user manual during installation, wiring,

- and connection to other control devices.
- (2) Using products beyond the specifications or standards of the manual.
  - (3) The storage method and working environment are beyond the appointed range (e.g. pollution, salt injury and moisture condensation).
  - (4) Products' damages caused by improper transportation.
  - (5) The damage caused by accidents or collisions due to failure to follow the operation and warning information.
  - (6) The damage caused by any thirdparty which is not the integrator or professional technician designated by *our company* while reconstructing, adjusting, or repairing the original components.
  - (7) Changes or damage to the software or internal data.
  - (8) The damage caused by natural disasters including fires, earthquakes, tsunamis, lightning, high winds, and flooding.

According to [6.1 Product Warranty \(page 83\)](#), *our company* only undertakes to guarantee against the flaws and defects in the products and components sold directly by *our company* or its designated or authorized distributors. The Company shall not be liable for any form of direct or indirect damage/consequences arising from other related products.



# Appendix **A**

## Guideline

---

**Table A.1** Lebai Robot Standard Guideline

Electromagnetic Compatibility	
GB/T17799.1-1999	EMC general standard, in residential and commercial environments
GB/T17799.4-2001	EMC general standard, in industrial environments
Performance	
GB/T12642-2013	Performance specification and test method of industrial robot
GB/T20868-2007	Implementation specification for performance test of industrial robot
Safety	
GB/T20867-2007	Specification of safety implementation of industrial robot
Acceptance	
JB/T8896-1999	Acceptance rules of industrial robot
JB/T10825-2008	Implementation specification for acceptance of industrial robot



There are two ways to obtain the *Online User Manual*, you can choose one of them:

- Visit the following address in your browser:



<https://1-d0c.lebai.ltd/lebai-manual/lebai-manual-en.pdf>

Scan for  
More...



## Shanghai Lebai Robot Co., Ltd

✉ oop@lebai.ltd

🌐 <https://lebai.ltd>

📍 No.889, Yishan Road, Xuhui, Shanghai

LEBAI 乐白