



**SKSGROUP**

EN

**SKS**CONTROL  
**SKS**MEKANIikka

QUALITY BEGINS WITH EXPERTISE

# SKS Control and SKS Mekaniikka - strong technical knowhow

**SKS Control Oy** is a specialist in control systems and drives. We serve machine builders and stage technology professionals. High-class products, technical know-how and long experience guarantee reliable deliveries from design to implementation and maintenance.

**SKS Mekaniikka** is an experienced professional in the machine building industry. Our wide product range covers the needs for power transmission and linear technics solutions as well as mechanical components. Strong technical know-how is a significant part of our service. We cooperate closely with our partners to ensure high-class solutions.

**SKS Group** offers application expertise and professional experience in close cooperation with our customers. We have long-term and excellent supplier relationships. In addition to supplying top-quality products, SKS Group offers the best services to help customers in all development stages of technical solutions.

SKS Group is part of Axel Johnson International, a global industrial group that acquires and develops companies in strategically selected niche markets, primarily technical components and industrial process solutions. Axel Johnson International comprises 200 companies in 34 countries. Axel Johnson International is part of the Swedish family-owned corporate group Axel Johnson.

## SKS Group suppliers

Ammega, Arbor Technology, Bonfiglioli, Bege, Cactus Technologies, Codesys, Columbus McKinnon, Compomac, Crevis, CSB, Danfoss, Delta Electronics, Delta Computer Systems, Diamond Systems, EKD, Elsa Solutions, Elte, Esco, ETP Transmission, Euroconnection, Gates Europe, Gewes, HBE, IMAnalytics, IPL Transmission, Janz Tec, JVL, Keba, KB Electronics, Kipp, Leroy Somer, Lika Electronic, Mavilor Motors, MayTec, Michael Koch, Motor Power Company, Motortronics, Murtfeldt, Nexcom, Nidec Control Techniques, Oemer, Paulstra, Renice Technology, ROSTA, Sati, Sinadrives, Sintrones, Sumitomo Cyclo, Suspa, Stieber, Tandler, TB Woods, Tecnotion, THK, Thomson, Tolomatic, Trenton Systems, Tsubaki, SIR, Vecow, Weintek, Wippermann, Xenarc Technologies

**"We are a longterm partner for our customers and suppliers and develop SKS Group constantly. Our skilled staff guarantee that customers receive the best expertise at all stages of the process."**

**Thomas Söderberg, CEO,  
SKS Mekaniikka Oy**

**"Close collaboration means providing product and production solutions that better meet customer needs. Our extensive expertise and long experience in the field contribute to the growth of our customers competitiveness."**

**Jussi Sirpoma, CEO,  
SKS Control Oy**

# Everything great consists of parts

SKS Group experts have fulfilled hundreds of machine building customer projects. Our solid experience, combined with detailed product knowledge, has resulted in first-class, customer-specific solutions. By making the right choices it's possible to lengthen machine life cycles and save energy.

High-quality products, technical expertise, and experience ensure reliable deliveries from design to implementations and scheduled maintenance of equipment. Our strengths lie in good supplier relationships and understanding customer needs, enabling us to assist in all stages of technical solution development. We implement comprehensive automation and mechanical systems, such as the modernization of machines and production lines, as well as testing equipment.

We continuously develop our product range based on feedback from our customers. By working closely with customers and our suppliers, we can guarantee state-of-the-art, reliable equipment solutions. Our own logistical and warehousing strengths ensure quick deliveries.

Our operations have decades of continuity and development - experience is made through doing, and trust is built on success.

**SKS Control Oy**  
**SKS Mekaniikka Oy**



Our versatile expertise, technical readiness, and extensive partner network ensure a competitive advantage in the implementation of mechanical machine components and stage technology solutions. Customers can benefit the most by concentrating all their mechanical and automation purchases in technically and logistically strong SKS Group.

SKS Group, part of Axel Johnson International, consist of companies SKS Control Oy, SKS Mekaniikka Oy and SKS Tehnika OÜ. SKS Group's turnover is around € 30,8 M with 100 employees.

# Linear motion products

SKS Mekaniikka's suppliers are leading developers of linear motion products. By making the right choices it's possible to lengthen machine life cycles and save energy. The linear motion product group suits applications that require high precision, speed and stability. High-quality products are the pre-requisite for customer success.

## Application examples



ROBOT WELDING STATION



PACKAGING MACHINE  
(KOCH PAC-SYSTEME GMBH)

## Linear motion

### THK linear guides

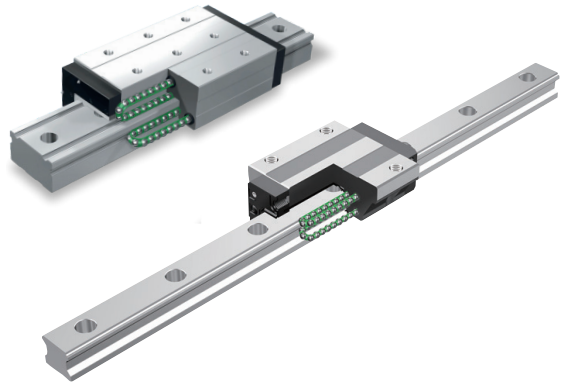

### Linear units

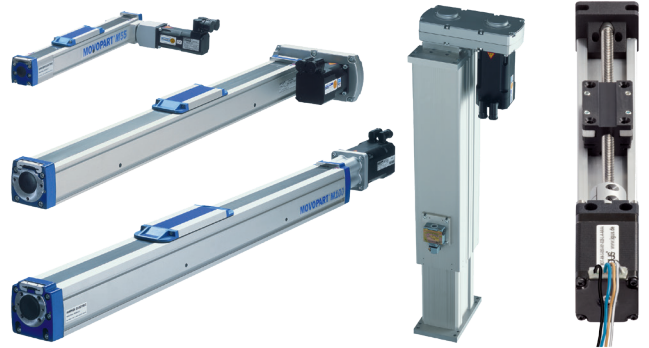

### Maintenance-free linear motion systems



Ball bushings

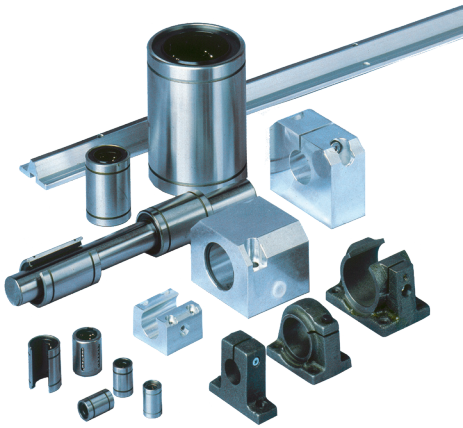

Slide guides and miniature linear guides



THK linear units

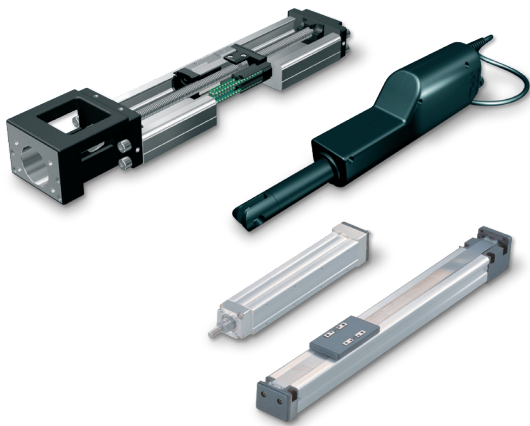

THK, other products

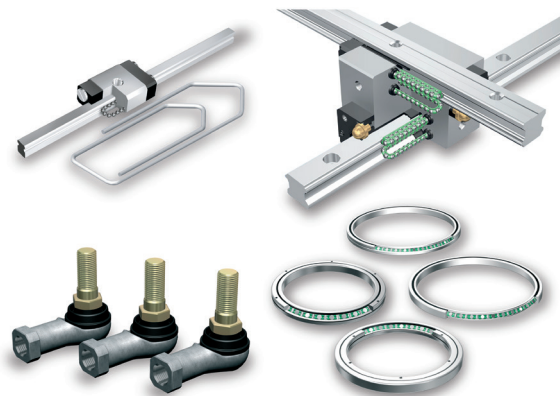

Trapezoidal and ball screws

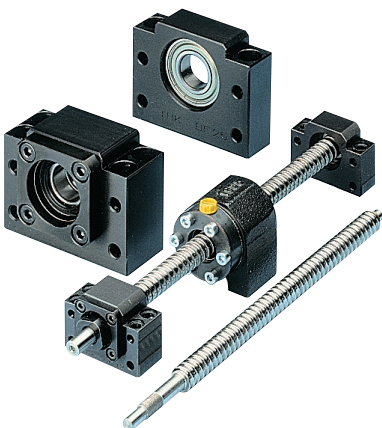

Linear actuators



# Mechanical machine components

We have energy chains for all practical needs. Technically suitable products extend the service life of chains, cables and tubes. Our aluminium profile systems can meet a wide variety of machine building needs, including demanding applications. Due to our machining and assembly service, we can deliver turnkey packages. We also have a large number of other mechanical machine components to cover the needs of equipment manufacturers.

## Application examples

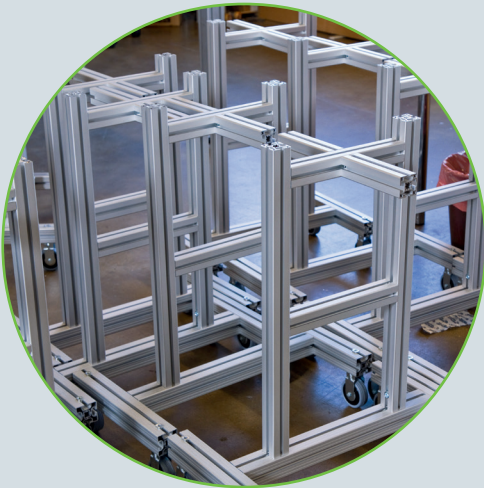

FRAMES FOR HEALTHCARE SECTOR ACCESSORIES



ENERGY CHAINS: TANDEM DRIVE

## Dampers

Damping pads and adjustable levellers

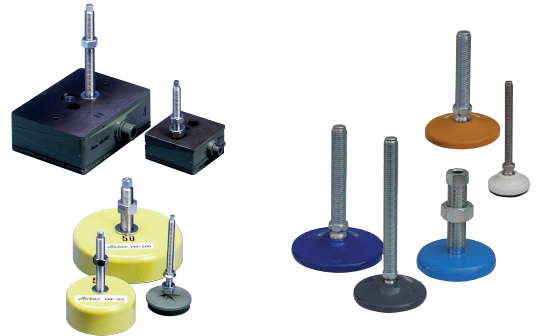

## Other components

Machine covers

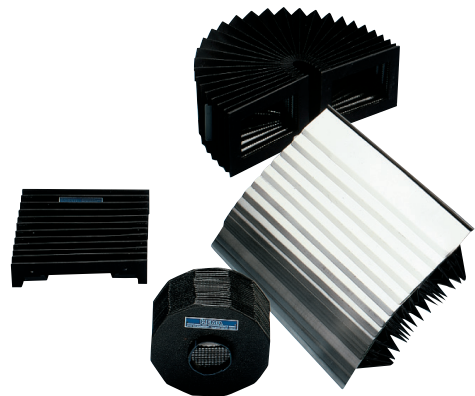

Aluminium profiles



Vibration dampers



Gas springs



Operating parts



Hand wheels



Industrial wheels



Aluminium profile systems



Polymer energy chains



Metal energy chains



# Gears and motors

Our full range of closed-loop gears and motors makes it easy to concentrate your purchases. The unique features of high-quality gears and motors ensure machine builders the opportunity to succeed on domestic and international markets. Our service package includes assembly and the customisation of products.

## Application examples



SWING AND TRAVEL DRIVES FOR WIND TURBINES



SWING AND TRAVEL GEARS FOR EXCAVATORS

## Gears and gear motors

Swing, bevel and angle gears

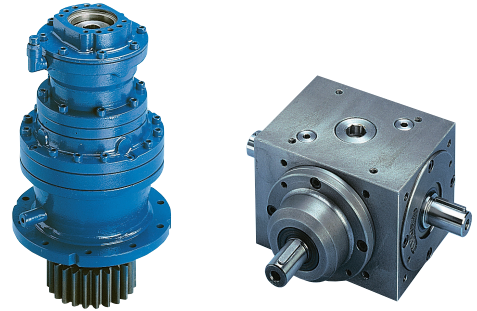

Helical bevel gears and gear motors

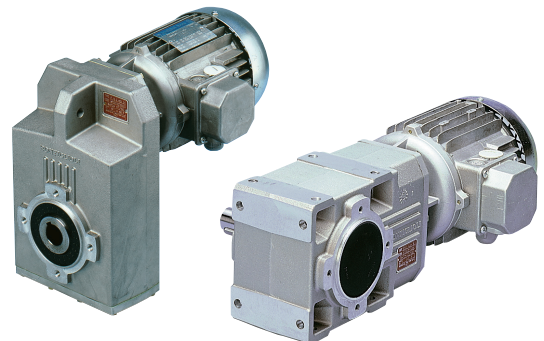

Induction motors

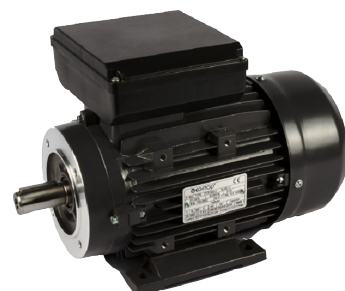



Precision gears

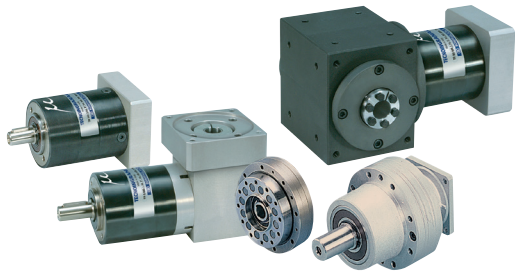

Helical gears

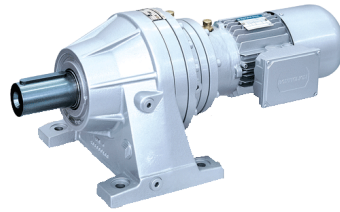

Worm gears and gear motors

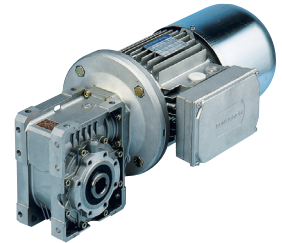

Coaxial gear motors



Industrial gears

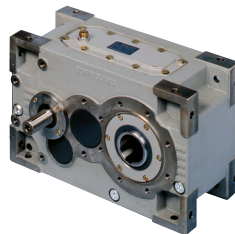

Cyclo gear motors

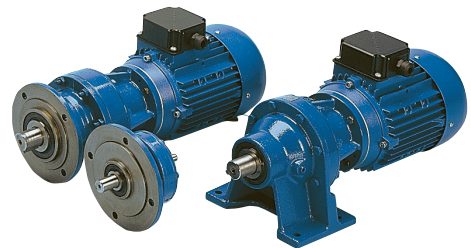

Screw jacks and actuators



Incremental encoders



Automatic lubrication



# Shaft joints

Our technical experts help customers find the most suitable shaft joint, considering performance, product lifecycle and price. The couplings and shaft joints in our product range are either standard constructions or tailored in line with customer drawings.

## Application examples

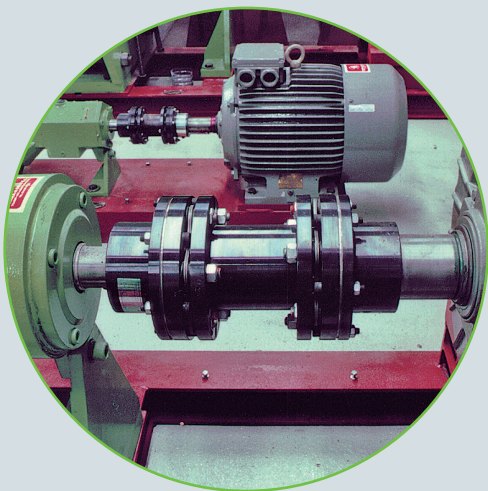

TORQUE TRANSFER WITH A DISC GEAR COUPLING

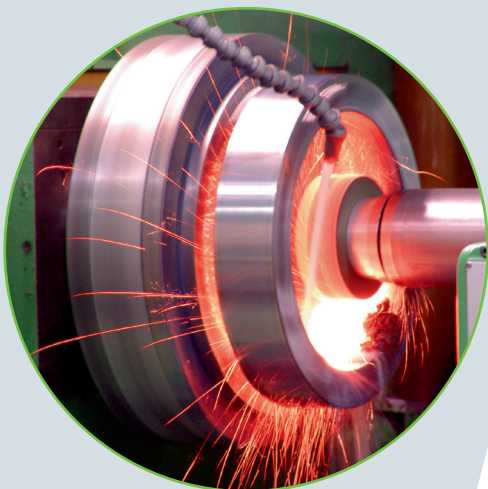

THE FREE WHEEL MANUFACTURING PROCESS

## Shaft joints

### Flexible couplings



Sure-Flex® ja Dura-Flex®, flexible couplings. electromagnetic couplings and brakes



### Universal joint shafts



Disk type couplings, gear couplings, clamp and flange couplings



Torque limiters

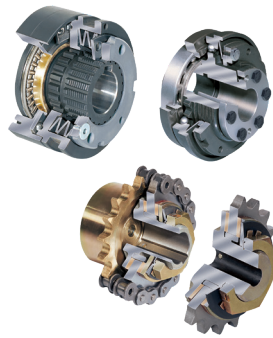

Precision couplings



Mechanical shaft-hub clamping bushes



ETP, hydraulic and stainless steel clamping bushes



## Magnets

Free wheel couplings

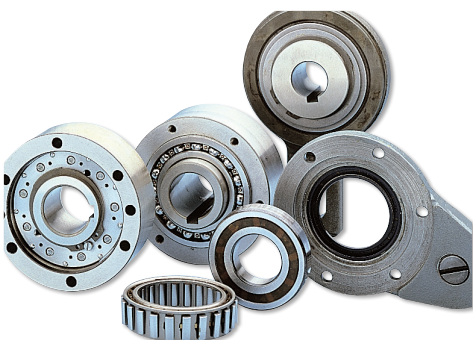

Magnets

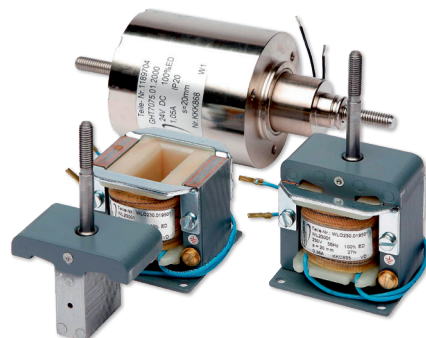

# Chain drives

SKS Mekaniikka's extensive range of chains provides economical solutions for each and every application. Whether you require long lifecycles, freedom from maintenance, maximum power handling capacity, or the ability to operate in demanding environments, the special components of our reliable suppliers will cover for your needs.

## Application examples

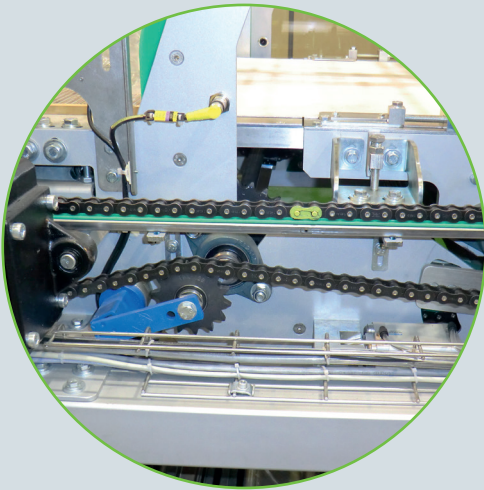

POWER TRANSMISSION CHAIN DRIVES FOR CONVEYORS



MOTOR BASES

# Chain drives

## Power transmission chains



## Special chains



## Sliding guides



Leaf chains

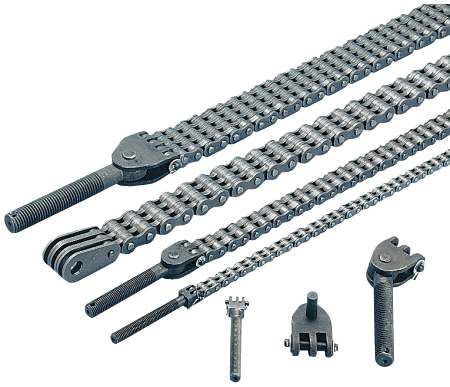

Maintenance-free chains

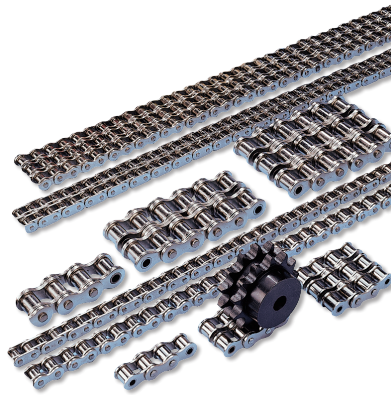

Chains for demanding environments



Sprockets

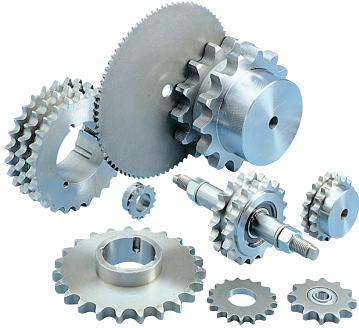

Sprockets, racks and tapered wheels

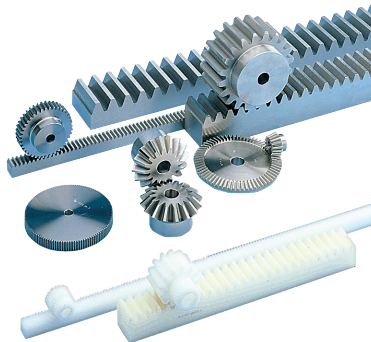
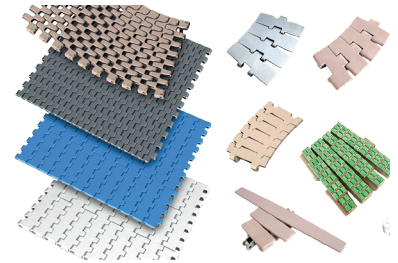

Plate chains, modular belts and conveyor components



Chain and belt tensioners



ROSTA chain and belt tensioner devices

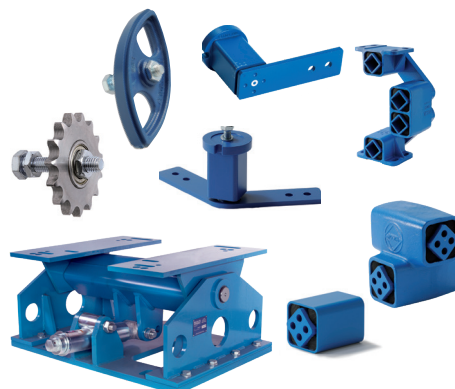

## Belt drives

SKS Mekaniikka's belt product group represents leading expertise. The products of our suppliers, Gates and Megadyne, combine quality and reliability. The Gates belts – Predator, PowerGrip GT4 and Poly Chain GT Carbon – transmit power efficiently and suit applications requiring great durability and wear-resistance.

### Application examples

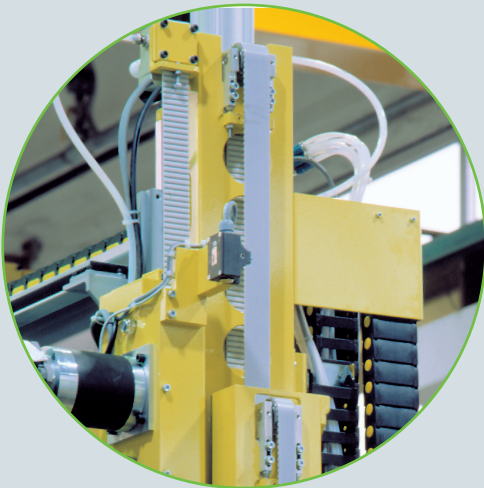

PU SYNCHRONOUS BELT DRIVES



V BELT DRIVES FOR SAWMILL MACHINERY

## V belt drives

V belt and flat belt drives, conical sleeves



## Synchronous belt drives

POWERGRIP® GT4, synchronous belt drives



HTD® synchronous belt drives

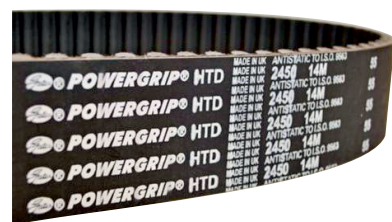

### INDUSTRIAL V BELTS-

Quad-Power® 4

- Super HC®
- Hi-Power®
- Delta Classic™
- Delta Narrow™



### MICRO-V BELT DRIVES



### PREDATOR®

V belts for extreme applications



### PU synchronous belt drives

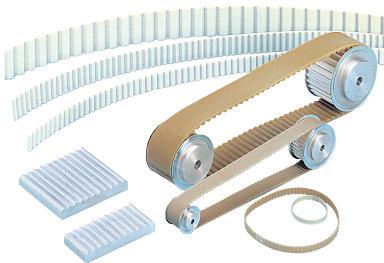

### POLY CHAIN® GT CARBON™ VOLT™ drives



### Classical synchronous belt drives



## Other products

Laser alignment device  
for belt drives



SONIC TENSION, tension meter



## Bearings and slew rings

SKS Mekaniikka's bearings group includes various slide bearings, plain bearings and slew ring bearings. We stock thin-walled, metal-based and polymeric slidebearing solutions, as well as bearings cut to size from different materials. The range of slewing ring bearings consists of rings equipped with external and internal teeth or without teeth. The most common types of material used for the ring are CK50, 42CrMo and polymer blends.

### Application examples



THE PROCESS OF CASTING BRONZE TUBES



SLEWING BEARINGS FOR LIFTING APPLICATIONS

## Bearings

### Slide bearings



### Polymeric bearings

#### Polymeric bearings



### Parts according to customer drawings

#### Hardened bushings





Graphite bronze bearings



Bearings cut to size



## Slewing ring bearings

Slewing ring bearings

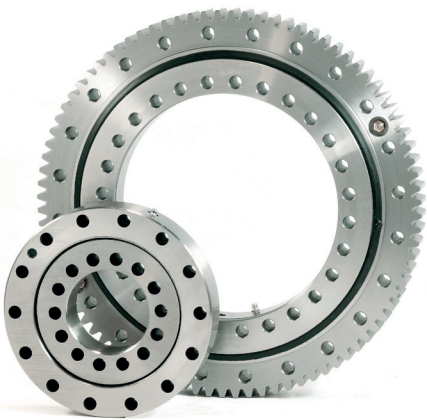

Maintenance-free slewing ring bearings



Machine parts

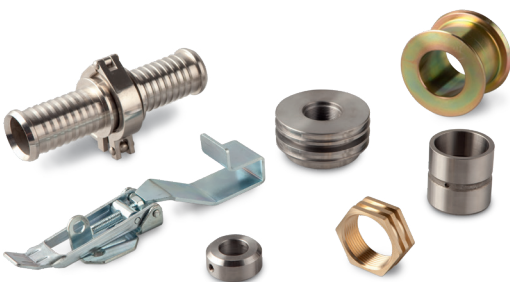

# Electric drives

SKS Control's extensive know-how combined to globally known suppliers constitutes a strong competitive advantage for the customer.

## Application examples

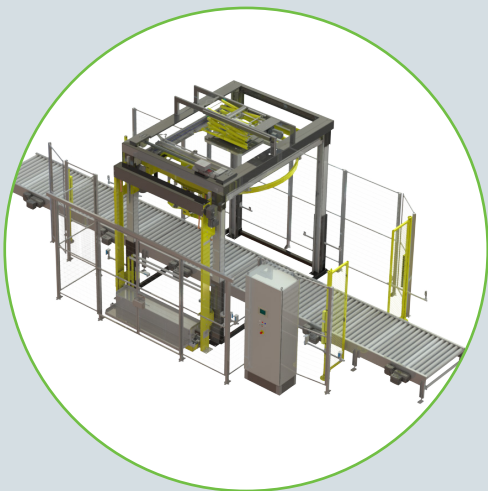

WRAPPING MACHINES  
Customer: Haloila Oy

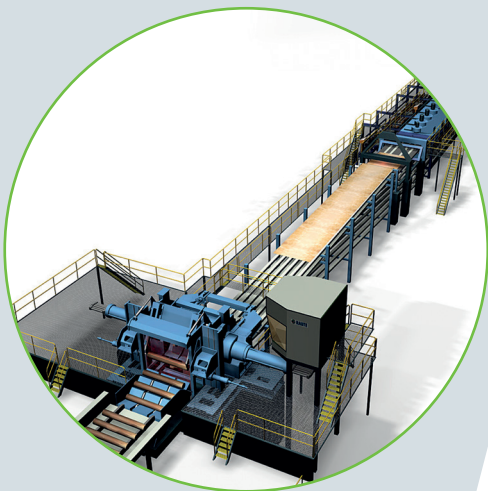

SMART PEEL -VENEER LATHES  
Customer: Raute Oyj

## Drives and servo drives

### IC-SERIE

Drives for the process industry



### VLT® REFRIGERATION FC 103 drives



### VACON® 100 Industrial drives



VLT® -serie

VLT® Automation FC 302 drives



VLT® AQUA FC 202 drives



VLT® HVAC FC 102 drive



VACON® 100 X-  
drives



VACON® 100 FLOW  
drives



VACON® NXP  
drives



VARIABLE FREQUENCY DRIVES  
IP65



CFP2000  
IP55 drives for pump and blower applications



## Accessories Linear technics

Our range of electrical appliances includes servo drives, DC drives and frequency converters with various protection class requirements, along with accessories.

### Application examples



VENEER HANDLING MACHINERY  
Customer: Plytec Oy



MANUFACTURING SOLUTIONS  
Customer: Ginolis Oy  
(Tecnotion linear motors)

## Braking energy recovery and reserve supply

DES and DEVI Brake resistors



## Encoders

Encoders and position measuring systems



## Linear technics

Linear motors



# Accessories

BR-Brake resistors and EMC-filters



Power resistors



SI Option cards



CABLES  
Custom made servo cables



Linear actuators

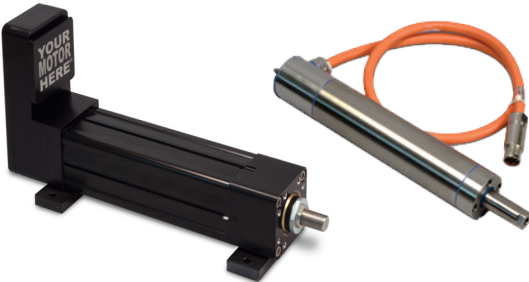

Linear servo motor units



# Motors

SKS Control's product range represents the latest technology, which allows significant increase in energy efficiency. Electric-mechanical actuators and high-efficiency permanent magnet motors can replace low-efficiency in relation to pneumatic and hydraulic solutions.

## Application examples

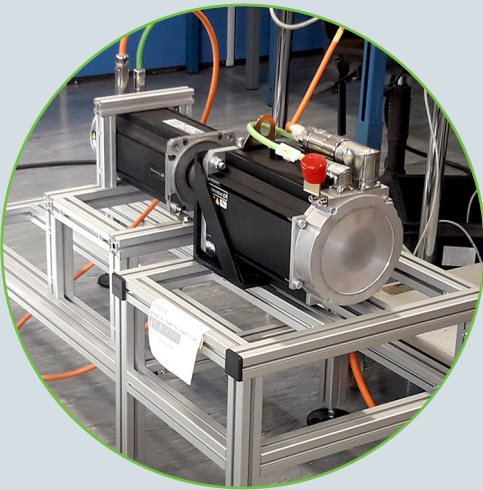

TEST DEVICE FOR ELECTRIC MOTORS  
Customer: South-Eastern Finland University of Applied Sciences



RAIL DRILLING MACHINE  
Customer: Vossloh Rail Services Finland Oy

## Motors

Permanent-magnet motors and permanent magnet reluctance motors



## Servomotors



IEC induction motors  
Brake induction motors

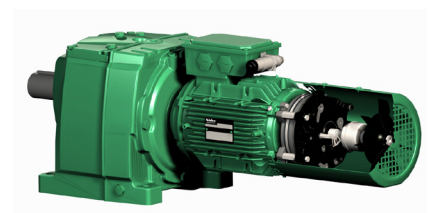

Permanent-magnet motors

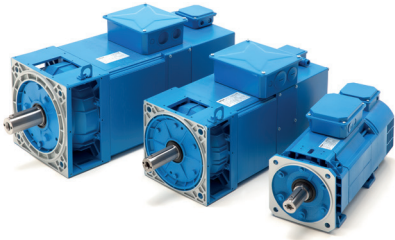

Torque motors



Asynchronous servomotors and Synchronous servomotors



Asynchronous servomotors

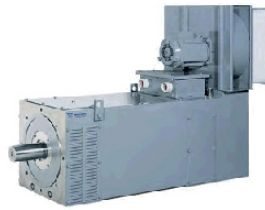

Integrated stepper motors



AC motors



Saw motors and high speed precision spindles



AC generators



# Automation and motion control

CODESYS programmable logic controllers, industrial PCs, and fieldbus I/Os combined with next-generation motion controllers provide the opportunity for open-architecture control systems. These systems combine the scalability of programming and controls with cost-effectiveness. Additionally, the best solutions for machine control can be selected from our global suppliers' products.

## Application examples

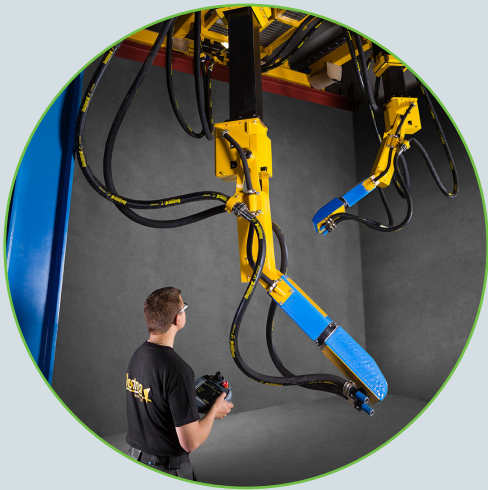

PLAST CLEANING ROBOTS  
Customer: Blastman Robotics Oy  
(Keba Mobile operating devices)



T-DRILL S-54-COLLARING-MACHINES  
Customer: T-Drill Oy  
(Weintek HMI operating devices)

## Motion control

ACN-motion control system



## Control units



## Visualization and Runtime System

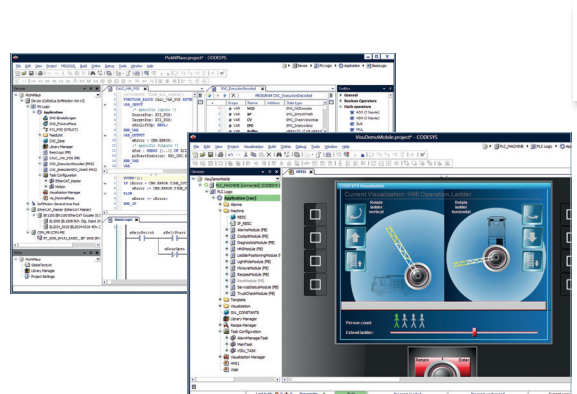



Motion controls

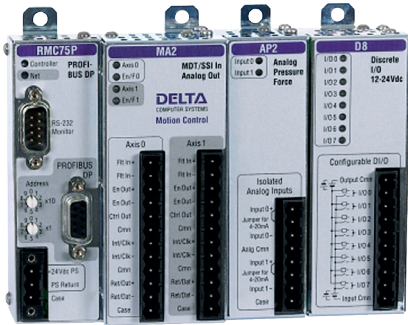

Soft Motion motion controller



Softmotion

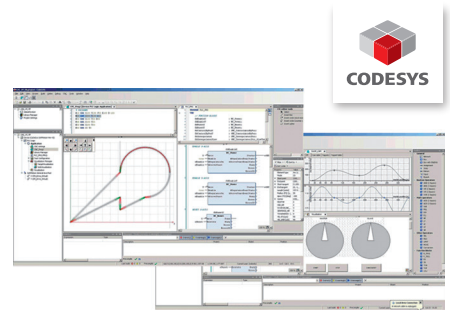

User interfaces

Mobile operating devices



HMI solutions



Distributed I/O

Modular fieldbus I/O



IIoT

Condition monitoring solutions

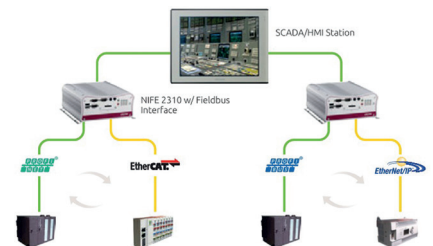

# Industrial and Mobile IT

Our product range in industrial and mobile IT includes industrial computers, industrial storage devices, in-vehicle computing solutions, in-vehicle display solutions, power supplies, and condition monitoring solutions. The product range is particularly suitable for industrial automation, public transportation, and defence industry applications.

## Application examples



PASSENGER INFORMATION SYSTEM  
Asiakas: Neonmedia Oy  
(In-Vehicle display solutions)



SOLUTIONS FOR MINING  
INDUSTRY  
Panel PC, SKS solutions

## Industrial IT and IoT

Storage devices



## Mobile IT

In-Vehicle display solutions



Embedded systems



Storage devices



DC power supplies



In-Vehicle computing solutions



Network communication components



Box and panel PCs



## Stage technology

We design and engineer stage mechanics and stage control systems for demanding customer needs. We have succeeded when the audience does not notice our solutions. Reliability, operational safety, customer oriented approach and sustainability are important values for us.

### Application examples



RISING TIDE BAR  
Luxury Cruise Ships



THE MODERNISATION OF THE  
MAIN STAGE  
Oulu Theatre

## Stage mechanics

### SKS batten hoists



### Curtain tracks and track systems

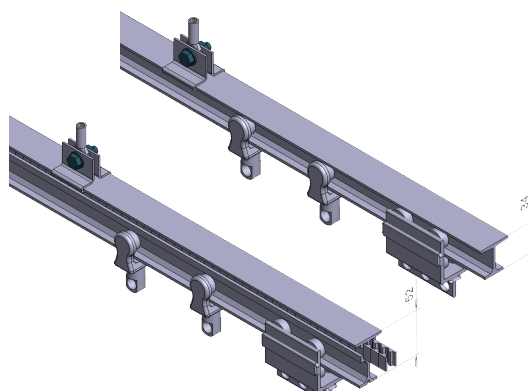

### Theatre mechanics

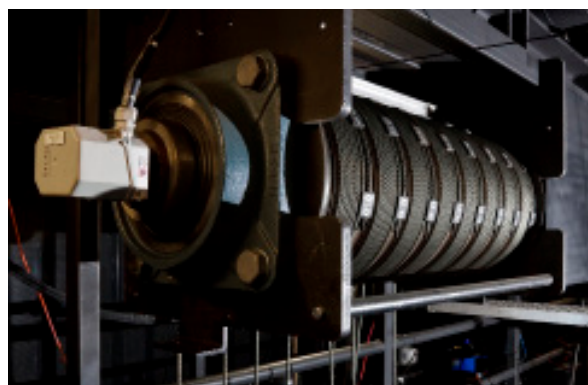

Lighting grids



SKS point hoists

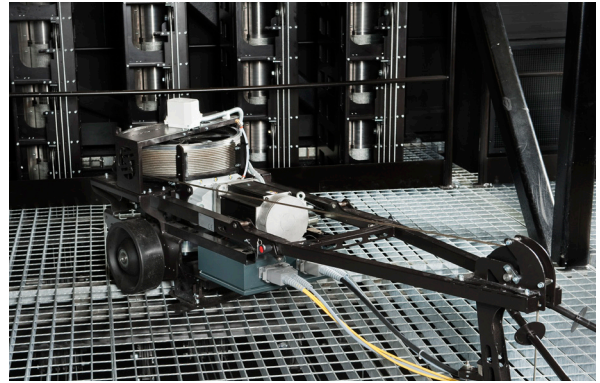

Stage curtains and fabrics



Visual Stage Motion control system



Stage gantries with equipment



Spare parts



# Understanding the customers expectations

Preventive maintenance program's benefits are great when unexpected break ups and faults can be minimized. Predictive maintenance ensures systems operational safety and makes it is easy to follow and predict the needs for spare parts and other services.

Our experienced engineers come on-site for manufacturer preventive maintenance inspection. They check the condition of the system and create a clear and cost-effective action plan that ensures operational safety for next season.

We take the responsibility over the operational safety of the stage technology solution right from the beginning to the end of the project including testing. The delivered solution includes designing, needed components and systems installed and after sales services such as maintenance, education, system modernizations and possible expansions. Turnkey solution provides cost savings over single systems and components.

We provide remote support 24/7, along with training.

## Stage technics maintenance

### Safety inspections



### Mechanical maintenance and service



### Software updates

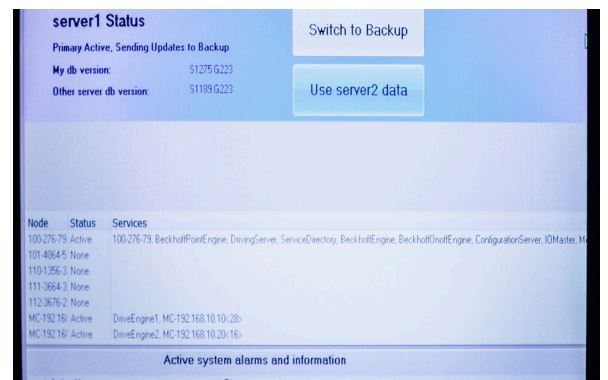

## Support



## SKS safetycard



## Motion control and electrical system services

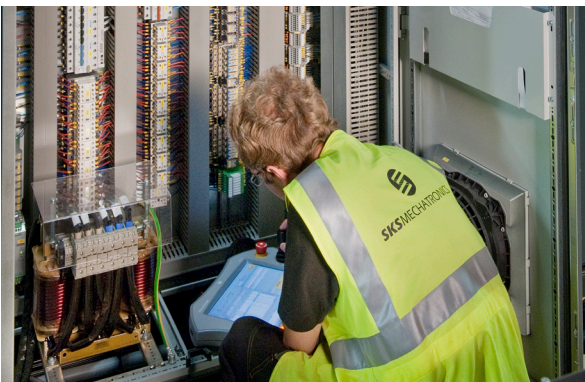

## Electrical work



## Remote support



## Training

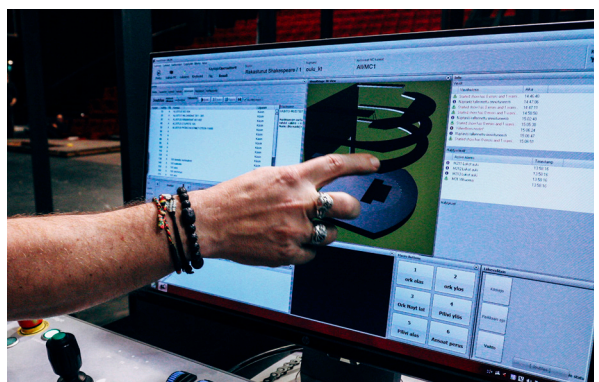

## Services for your needs

Correctly chosen products will operate as planned through their life time and save service and maintenance costs.

SKS Mekaniikka's specialists will advise you in all matters concerning product selection. We take responsibility for individual components, for assembly, and for overall deliveries. Our versatile assembly and machining services allow us to tailor products for each customer, while our customer service produces any special solutions you might need.

## Ready for right measurements

The logistics and service centre in Vantaa, Finland, has a machine workshop, chain workshop, gear motor assembly shop, profile cutting, drilling and milling lines, and a cut-to-size and installation service for linear guides. The machine workshop's versatile machine tools and skilled employees cooperate with SKS Mekaniikka's sales team to ensure that each customer's needs are met flexibly and reliably.

Mechanical components machining



Gear and motor assembly



Chain cutting and assembly

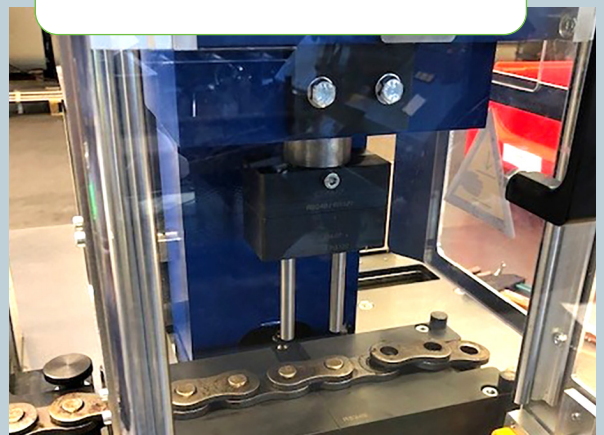



Aluminium profile cutting and assembly



Energy chains assembly



Linear guides cutting and assembly

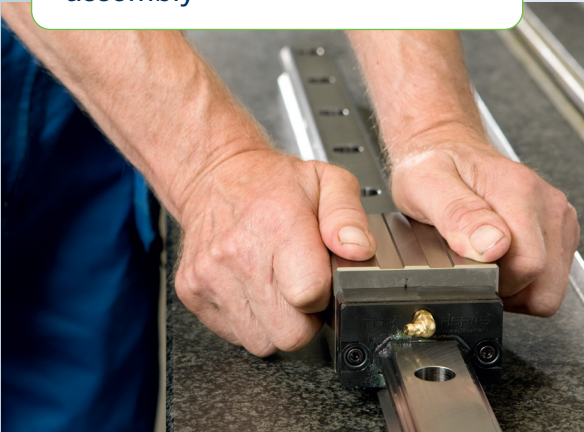

Technical support



24/7 warehouse service



## Best service

The close collaboration with the product manufacturers and our expertise in design of applications and systems help us to provide our customers high quality products and best service.

SKS Control is known for its strong expertise in motion control and stage technology control systems and stage mechanics.

## Reliable deliveries

**SKS Group** pays special attention to logistical excellence. Our ample warehouse stock is ready for immediate delivery. If the customer wishes, we can also store customer-specific items.

The 24/7 service takes care of deliveries when there are urgent needs outside office hours and on weekends.

### Training



### Design



### Service, maintenance and remote support



Technical support



Solution sales



Testing

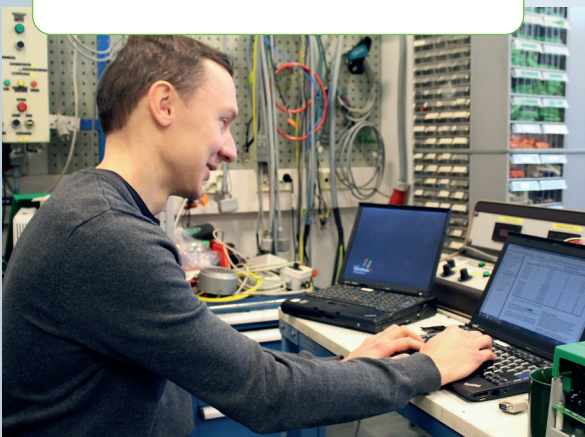

Programming



Projects



Repairs





**SKSGROUP**

**SKS CONTROL OY**

Martinkyläntie 50,  
PO Box 122, FI-01721 Vantaa, Finland  
Tel +358 20 764 5000  
control@sk.fi, www.sk.fi

**Warehouse and Service Center**

Martinkyläntie 50,  
FI-01721 Vantaa, Finland

**SKS MEKANIikka OY**

Martinkyläntie 50,  
PO Box 122, FI-01721 Vantaa, Finland  
Tel. +358 20 764 5000  
sales.mekaniikka@sk.fi, www.sk.fi

**Southern Finland Area Office**

Martinkyläntie 50,  
FI-01721 Vantaa, Finland

**Middle Finland Area Office**

Sarvijaakonkatu 5b B,  
FI-33540 Tampere, Finland

**Western Finland Area Office**

Juhana Herttuan Puistokatu 21,  
FI-20100 Turku, Finland

**Warehouse**

Martinkyläntie 50,  
FI-01721 Vantaa, Finland

**24/7 service number**

+358 50 301 9848 (Vantaa, Finland)

**SKS Group**

SKS Control Oy

SKS Mekaniikka Oy

SKS Tehnika OÜ  
(Tallinn, Estonia)

www.sk.fi  
sksgroup@sk.fi