

ROSA[®] Knee

User Manual & Surgical Technique V1.4



Table of Contents

1. General Information	1
1.1 Conventions.....	1
1.2 ROSA Knee System Description	1
1.3 Contact.....	2
1.4 Training	2
1.5 Intended Use	2
1.6 Indications for Use	2
1.7 Contraindications	3
1.8 Complications.....	3
1.9 Restrictions for Use.....	3
1.10 Patents.....	3
2. About This Manual	4
2.1 Safety	4
2.1.1 Warnings, Cautions and Remarks	4
3. Description	8
3.1 Overview	8
3.2 Operating Principle	9
3.2.1 Case Information	9
3.2.2 Pre-operative Planning	9
3.2.3 OR Setup.....	9
3.2.4 Robotic Unit Registration.....	10
3.2.5 Bony Landmarks & Navigation.....	11
3.2.6 Planning.....	11
3.2.7 Surgery	11
3.3 System Description.....	11
3.3.1 Robotic Unit.....	11
3.3.1.1 Robotic Arm.....	13
3.3.1.2 Touchscreen	14
3.3.1.3 Immobilization System	14
3.3.1.4 Vigilance Device (Foot Pedal).....	14
3.3.2 Optical Unit.....	15
3.3.3 Instrumentation	16
3.3.3.1 ROSA Arm Instrument Interface	17
3.3.3.2 ROSA Arm Reference Frame	18
3.3.3.3 ROSA Base Reference Frame	18
3.3.3.4 ROSA TKA Cut Guide	18
3.3.3.5 ROSA Registration Pointer	18
3.3.3.6 Universal Validation Tool Body	18
3.3.3.7 Distal & Posterior Condyles Digitizer.....	18
3.3.3.8 ROSA Knee Condyle Digitizer Small/Medium/Large .	18
3.3.3.9 ROSA Knee Tibia Validation Tool	19
3.3.3.10 Patient References.....	19
3.3.3.10.1 Femoral Reference Frame	19
3.3.3.10.2 ROSA Tibia Reference A/B.....	19
3.3.3.10.3 Offset 2 Pins Reference Tibia	20

3.4 Instrumentation Assembly	21
3.4.1 ROSA Arm Instrument Interface on the Robotic Arm	21
3.4.2 ROSA Arm Reference Frame on the Robotic Arm	22
3.4.3 ROSA Base Reference Frame on the Robotic Unit.....	22
3.4.4 ROSA TKA Cut Guide on the Robotic Arm	22
3.4.5 Universal Validation Tool Body and ROSA Knee Tibia Validation Tool (or Distal & Posterior Condyles Digitizer).....	23
3.4.6 Universal Validation Tool Body and Condyle Digitizers (ROSA Knee Condyle Digitizer/Distal & Posterior Condyles Digitizer).....	23
3.5 Disposables	23
3.5.1 Reflective Trackers (NavitrackER®) Installation	23
3.5.2 Pins	25
3.5.3 ROSA Checkpoint Screws	25
3.5.4 Drapes	25
4. Installation.....	26
4.1 Warnings and Cautions About Robotic Unit Installation	26
4.2 Device Start Up.....	27
4.3 Camera Errors	27
4.3.1 Camera Temperature is Too Low/High	27
4.3.2 Camera was Bumped	27
4.4 Emergency Procedure	28
4.5 Reverting to Standard Instrumentation	28
4.6 Case Management Application	29
4.6.1 Case Management Application-Interface Overview	29
4.6.2 Starting a Case	29
5. Intra-operative Guide/Surgery.....	30
5.1 Welcome Screen	30
5.2 ROSA Knee Application-User Interface Overview	30
5.2.1 Top Task Bar	31
5.2.1.1 Panel Buttons	31
5.2.1.2 Case Information	31
5.2.2 Bottom Task Bar	32
5.2.2.1 Menu	32
5.2.2.2 Camera.....	33
5.2.2.3 Snapshot	33
5.2.2.4 HKA.....	33
5.2.2.5 Bone Reference Checkpoint (optional)	33
5.3 Robotic Modes	34
5.4 Robotic Positions	34
5.5 Application Audio Notifications.....	35
5.6 Application Visual Notifications.....	35

5.7 ROSA Knee Application-SURGEON Panel	36
5.7.1 Femoral Rotation Axis Display	37
5.7.2 Knee State Evaluation	37
5.7.3 Femoral Rotation Tool	37
5.7.4 Flexion Angles for Stress Tests	37
5.7.5 Bone Reference Checkpoint	37
6. ROSA Knee Application-SETUP Panel	38
6.1 OR Setup	38
6.2 Calibration of Sensor	38
6.3 Draping	39
6.4 Touchscreen Monitor Draping	40
6.5 ROSA Knee Positioning	40
6.6 Camera Positioning	41
6.7 ROSA Knee Registration	42
6.8 Bone References	42
6.8.1 Patient Femoral Reference	43
6.8.2 Patient Tibial Reference	44
6.8.2.1 ROSA Tibia Reference A/B	44
6.8.2.2 Offset 2 Pins Reference Tibia	45
7. ROSA Knee Application-FEMUR Panel	46
7.1 Femoral Head Center	46
7.2 Femoral Axis Point	47
7.3 Femur Checkpoint (Optional)	47
7.4 Posterior Condyles	47
7.5 Anterior and Posterior Trochlear Groove	48
7.6 Medial and Lateral Epicondyles	48
7.7 Medial and Lateral Distal Condyles	48
7.8 Anterior Cortex	49
7.9 FEMUR Panel-Error Notifications	49
8. ROSA Knee Application-TIBIA Panel	50
8.1 Tibia Checkpoint (Optional)	50
8.2 Malleoli	50
8.3 Medial Third Tubercle	50
8.4 Tibial Axis Point	51
8.5 PCL Insertion Point	51
8.6 Medial and Lateral Plateau Resection References	51
8.7 TIBIA Panel-Error Notifications	52

9. ROSA Knee Application-EVALUATION Panel (Optional)	53
10. ROSA Knee Application-PLANNING Panel	55
10.1 Planning Panel Overview.....	55
10.1.1 Implant Selection	55
10.1.2 Implant Manipulator.....	56
10.1.3 Frontal View	56
10.1.4 Lateral View	57
10.1.5 Tibia Axial View	58
10.2 Viewing Options	58
10.3 Balance Tool	59
10.4 Femoral and Tibial Components Planning	60
10.5 PLANNING Panel-Error Notifications	62
10.6 PLANNING Limits	62
11. ROSA Knee Application-RESECTIONS Drawer	63
11.1 RESECTIONS Drawer Overview	63
11.2 ROSA TKA Cut Guide Installation and Checkpoints	65
11.3 Femoral Distal Resection	65
11.4 Tibial Proximal Resection.....	67
11.5 Femoral Rotation (Optional)	68
11.6 Femoral 4-in-1 Resection.....	69
11.7 Checkpoint Screw Removal	71
11.8 RESECTIONS Drawer-Error Notifications.....	71
11.9 Final Knee State Evaluation (Optional)	72
11.10 Confirm Data	72
12. Robotic Errors	73
13. Post-operative Guide/Maintenance	75
13.1 Retrieval of Post-Surgical Log File	75
13.1.1 Surgeon Report.....	75
13.1.2 Investigation Logs.....	75
13.2 Shutdown	76
13.3 Cleaning, Disinfection and Sterilization	76
13.3.1 Cleaning the Robotic and Optical Units	76
13.3.2 Cleaning the Optical Camera	77
13.3.3 Instruments Reprocessing (Cleaning and Sterilization Methods)	77
13.3.3.1 Sterilization Parameters	78
13.3.3.2 ROSA Knee System Instrument Kit.....	78
13.3.3.3 ROSA Knee System Instrument Lifetime Expectancy..	81
13.4 Storage and Transport	81
13.4.1 Storage and Protection	81
13.4.1.1 Device Storage and Protection	81
13.4.1.2 Instruments Storage and Protection.....	81
13.4.1.3 Care of Cables and Connectors	81

13.4.2 Transport.....	82
13.4.2.1 Device Transport	82
13.4.2.2 Transport of ROSA Checkpoint Screws	82
13.5 Maintenance Operations.....	83
13.5.1 Installation.....	83
13.5.2 Daily Checks.....	83
13.5.3 Periodic Maintenance	83
13.6 Troubleshooting.....	84
13.7 Safe Disposal	87
14. Product Security Customer Control Considerations.....	87
14.1 Records Retention & Purging Historical Data	87
14.2 Physical & Environmental Security Controls	87
15. Technical Data.....	88
15.1 Labels & Symbols	88
15.1.1 Labels	88
15.1.2 Symbols on the Labels.....	91
15.1.3 Other Symbols on the Device	93
15.2 Technical Specifications	95
15.2.1 Environmental Specifications	95
15.2.2 Device Performance	95
15.2.3 Device Dimensions	96
15.2.4 Robotic Arm Working Range.....	97
15.3 Safety Classification & Standards	97
15.3.1 Cable Lengths.....	98
15.4 Electromagnetic Compatibility.....	99
15.4.1 Electromagnetic (EM) Emissions	99
15.4.2 Electromagnetic and Magnetic Immunity	100
15.4.3 Electromagnetic Immunity and Portable and Mobile Radio Frequency (RF) Communication Equipment	102
15.4.4 Recommended Separation Distances	103
16. Software Licenses.....	104
16.1 Boost	104
16.2 VTK	104
16.3 GDCM	105
16.4 ITK.....	105
16.5 Open SSL.....	107
Appendix A: Supported Implants and A/P Referencing of the ROSA Knee System	109
Appendix B: Implant Compatibility Between Femoral and Tibial Component Brands.....	112
Appendix C: Implant Compatibility Between Femoral and Tibial Component Sizes	112

1. General Information

1.1 Conventions

This document employs the following conventions:

 **WARNING:** This symbol is present when a warning alerts you to a potential danger to health or life.

 **CAUTION:** This symbol is present to prevent a risk of deterioration of the equipment in case of a handling error.

 **REMARK:** This symbol is present to provide a general observation or information related to procedures, events or practices that are recommended or essential for a successful operation.

1.2 ROSA Knee System Description

The ROSA[®] Knee System is used to assist surgeons in performing Total Knee Arthroplasty (TKA) with features to assist with the bone resections as well as assessing the state of the soft tissues to facilitate implant positioning intra-operatively.



The ROSA Knee System uses a Medical Device Data System (MDDS) called the Zimmer Biomet Drive Portal, which manages the creation and tracking of the surgical case. The case resides on the portal until it is uploaded to the ROSA Knee System before surgery. If the case is image-based, a 3D virtual bone model is generated pre-operatively by the PSI systems (uses X-Atlas[®] 2D to 3D Technology or MRI imaging inputs) to create a model of the patient's femur/tibia and allows the preparation of a pre-operative surgical plan.

1.2 ROSA Knee System Description (cont.)

The intra-operative workflow and surgical concepts implemented in the system remain close to the conventional TKA workflow. As such, at the time of the surgery and based on the surgical plan, the system mainly assists the surgeon in determining reference alignment axes in relation to anatomical landmarks, in planning the orthopedic implant's location based on these reference alignment axes and orthopedic implant geometry, in assisting in joint balancing and in precisely positioning the Cut Guide relative to the planned orthopedic implant location by using a Robotic Arm.

 **CAUTION:** Federal Law restricts this device to sale by or on the order of a physician.

1.3 Contact

Zimmer CAS
75, Queen Street, Suite 3300
Montreal (Quebec), H3C-2N6 CANADA
Tel.: +1-514-396-5422
ROSA Knee System Customer service: +1-514-396-5422, +1-866-3D-ORTHO
zimmerbiomet.com

1.4 Training

This device is a surgery assistance tool. It should only be used by authorized surgeons and healthcare professionals trained in the use of the device by Zimmer Biomet or by personnel authorized by Zimmer Biomet. It is not a replacement for the surgeon's expertise and experience.

1.5 Intended Use

The ROSA Knee System, for use with the ROSA[®] Recon platform, is intended to assist the surgeon in providing software-defined spatial boundaries for orientation and reference information to anatomical structures during orthopedic surgery procedures. The system can also be used to assist in joint balancing techniques.

 The device must only be used for its intended use.

1.6 Indications For Use

The ROSA Knee System, for use with the ROSA Recon platform, is indicated as a stereotaxic instrumentation system for total knee replacement (TKA) surgery. It is to assist the surgeon in providing software-defined spatial boundaries for orientation and reference information to identifiable anatomical structures for the accurate placement of knee implant components.

The Robotic Arm placement is performed relative to anatomical landmarks as recorded using the system intra-operatively, and based on a surgical plan, optionally determined pre-operatively using compatible X-ray or MRI-based surgical planning tools.

It includes a Robotic Arm, an optical tracking system and accessories, software system, surgical instruments and accessories.

The ROSA Knee System is designed for use on the skeletally mature patient population. The targeted population has the same characteristics as the population that is suitable for the implants compatible with the ROSA Knee System.

The ROSA Knee System is to be used with the following fixed bearing knee replacement systems in accordance with their indications and contraindications: NexGen[®] CR, NexGen CR-Flex, NexGen CR-Flex Gender, NexGen LPS, NexGen LPS-Flex, NexGen LPS-Flex Gender, Persona[®] CR, Persona PS, Persona Ti-Nidium[®] CR, Persona Ti-Nidium PS, Persona IQ[®], Vanguard[®] CR, and Vanguard PS.

When Personalized Alignment™ will be used with the ROSA Knee System, it is highly recommended to reference the Personalized Alignment Surgical Technique (1578-GLBL-en) and follow the indications/
 contraindications found within that include (but are not limited to): Persona® CR Implant System with the Cruciate Retaining (CR), Medial Congruent (MC), or Ultra Congruent (UC) Bearing and cemented femoral and tibia components without a stem extension. Preservation of the PCL is preferred.

1.7 Contraindications

The ROSA Knee System may not be suitable for use in case of:

- Hip pathology with significant bone loss (e.g. avascular necrosis of the femoral head with collapse, severe dysplasia of the femoral head or the acetabulum)
- Hip pathology severely limiting range of motion (e.g. arthrodesis, severe contractures, chronic severe dislocation)
- Active infections of the knee joint area
- Knee replacement revision surgery
- Presence of strong infrared sources or infrared reflectors in the vicinity of the NavitrackER devices
- Implants that are not compatible with the system
- Contraindications for the implant as given by the implant manufacturer

1.8 Complications

Possible complications associated with the use of the ROSA Knee System may include but are not limited to the following:

- Infection
- Implant misalignment
- Unstable joint due to erroneous soft tissue balancing

1.9 Restrictions For Use

The ROSA Knee System described in this User Manual should not be used in combination with other products or components unless such other products or components are expressly recognized as compatible with ROSA Knee System. The list of compatible instruments is provided in section 3.3.3.

- The ROSA Knee system should not be used to perform surgery in applications other than those specified in this User Manual.

 The device must only be used after reading this User Manual and after receiving the appropriate training. Please contact Zimmer Biomet's Customer Service if unsure how to use the device.

 MR Unsafe: Keep away from Magnetic Resonance Imaging (MRI) Equipment.

1.10 Patents

Patents available online at zimmerbiomet.com/patents

2. About This Manual

This User Manual provides detailed information about the ROSA Knee System. Further, in this document, the ROSA Knee System can be referred to as “the device”. This manual is considered as the reference document for users. It is not a technical maintenance or service manual. For technical instructions about the device, please contact Zimmer Biomet’s Customer Service or one of its approved representatives. A troubleshooting guide is provided in Chapter 13- Post-operative Guide/Maintenance of this manual (section 13.6).







-  The device must only be used after reading this User Manual and after receiving the appropriate training. Please contact Zimmer Biomet’s Customer Service if unsure how to use the device.

2.1 Safety



2.1.1 Warnings, Cautions and Remarks

The correct use of this equipment implies that all the operating staff are familiar with the Instructions for Use. This manual must be carefully studied before using the device. Particular attention must be paid to the safety instructions related to people and the device.





Training, Use and Maintenance

-  Only properly trained, qualified personnel with appropriate credentials should operate the device. Users must follow safety guidelines and warnings.
-  The device must only be used for its intended use.
-  The device must only be used after reading this User Manual and after having received the appropriate training. Please contact Zimmer Biomet’s Customer Service if unsure how to use the device.
-  Do not open the device. In case of any issue or breakdown, do not intervene. Maintenance and service operations must only be carried out by Zimmer Biomet’s Customer Service or any of its approved representatives. Do not modify the device.
-  Never attempt to clean the device when it is connected to a power supply. To avoid electrical discharges, always unplug the device from the wall outlet before cleaning or disinfecting it.
-  A knee positioner, such as the De Mayo Knee Positioner®, is recommended to be used with the ROSA Knee System, otherwise accuracy may be impacted.
-  When used in compliance with the indications for maintenance, the device can be run in permanent operation.

Electrical Safety







-  In order to avoid any risk of electric shock, the device must only be connected to an electric power network equipped with grounding. Device is class I, type BF.
-  Do not simultaneously touch the patient and any component of the device other than those attached to the electrical isolation interface part.

2.1.1 Warnings, Cautions and Remarks (cont.)





-  IPX0 Protection: Device without special protection against the penetration of liquids. Do not pour any liquid over the device.
-  Do not exceed the recommended input voltage for the device. Plugging the device to a higher voltage supply could damage the device.
-  In order to prevent accidental detachment of connectors, ensure the metallic ring is attached to the Robotic Unit's hook, if applicable.
-  Verify the metallic ring of the Optical Unit cable is attached to the hook on the Rear Panel of the Robotic Unit to ensure electromagnetic compatibility (EMC) protection, if applicable.
-  Do not connect any other elements to the Robotic Unit than those provided with the device.

Radiation Safety

Risks generated by laser beam exposure: The device uses a laser integrated into the navigation camera.

-  This laser is of class 2 (power inferior to 1 mW, eye protection by the palpebral reflex). Do not orient the laser beam to the eyes or to any light-reflecting surfaces (such as mirrors) to avoid any direct or indirect exposure to laser beam.
-  Do not orient the laser towards the patient's eyes, the user's eyes or anyone else's eyes.
-  MR Unsafe: Keep away from Magnetic Resonance Imaging (MRI) Equipment.
-  The device requires specific precautions regarding the EMC. It must be set up and initiated according to the EMC information provided in this User Manual.
-  Portable and mobile radio frequency communication devices might affect the operation of the device.
-  Usage of accessories, transducers and cables other than those specified in the User Manual, with the exception of the transducers and cables sold by Zimmer Biomet (as spare parts of internal components), might cause increased emissions or decreased immunity of the device.
-  The device must not be used adjacent to or stacked on top of any other equipment. If necessary, verify its correct operation in the corresponding configuration.









Risks Related to Transport and Immobilization

-  Ensure that the Robotic Unit is not moving once the immobilization system is locked.
-  Risk of pinching: Do not place fingers or feet under the stabilization feet before immobilization of the system.
-  Verify the position of the device and its environment when using the Robotic Unit immobilization system.
-  During transportation, the device can be immobilized by activating the Immobilization Pedal. Do not install the device on an inclined surface, unless stability is guaranteed.











Mechanical Safety

-  Ensure that the Foot Pedal is operating correctly before beginning a procedure. Visually inspect the device and perform a test for interruption/resumption of a Robotic Arm movement.

2.1.1 Warnings, Cautions and Remarks (cont.)

-  Risk of collision: When the Robotic Unit is in Automatic mode, stay clear of the Robotic Arm and its path to the next position.
-  Risk of arm dropping-off: Do not lean on the Robotic Arm.
-  Risk of pinching: Do not place fingers in accessible parts of the plastic covers of the Robotic Arm.
-  Risk of tracking interruption: Avoid passing obstacles between the camera and the patient reference or the Robotic Unit reference.
-  Risk of navigation camera motion: Do not lean on the camera support arm.
-  Verify the proper fixation of the navigation camera on the Optical Unit.
-  The operating table must not be moved once an instrument guided by the Robotic Unit is connected to the patient anatomy.
-  Test the Tracking mode before any instrument guided by the Robotic Unit is connected to the patient anatomy.

Instruments

-  Before every surgery, the user must verify that all instruments have been sterilized.
-  Verify the integrity of all the instruments prior to each surgery. Visually inspect the instruments for damages.
-  Verify the proper fixation of the NavitrackER devices on each instrument (ROSA Base & Arm Reference Frame, ROSA Registration Pointer, Tibial & Femoral Reference Frame and Universal Validation Tool Body). Always use the NavitrackER pliers for installation.
-  Verify the proper fixation of the percutaneous pins in the patient's bone anatomy (femur and tibia).
-  Verify the proper fixation of the patient references on the pins (femur and tibia). The femur and tibia references are secured on the pins, close to the patient's skin (without compression), using two hexagonal screws.
-  Bone references **MUST** be firmly attached to the bone and **MUST NOT** move at any point during surgery. If a bone reference has moved, the landmarks digitized on that bone must be digitized again.
-  Always verify the proper installation of an instrument to the Robotic Unit or Robotic Arm by making sure screws are firmly tightened.
-  Verify the proper assembly of the Universal Validation Tool Body and the Distal & Posterior Condyles Digitizer before the acquisition of the posterior condyles or before validating the tibial proximal resection.
-  Verify the proper assembly of the Universal Validation Tool Body and the ROSA Condyle Digitizers before the acquisition of the posterior condyles.
-  Verify the proper assembly of the Universal Validation Tool Body and the ROSA Tibia Validation Tool before validating the tibial proximal resection.

2.1.1 Warnings, Cautions and Remarks (cont.)

 Handle instruments with care. Avoid dropping instruments. Damage to an instrument can have a significant effect on the accuracy of the procedure and consequently, on the post-operative surgical outcome. At the end of the procedure, instruments are placed in their tray for sterilization.

 Do not apply excessive torque on screws when installing an instrument. Do not use power tools.

 Devices: 20-8020-190-00, 20-8020-191-00, 20-8020-192-00 and 20-8020-193-00 contain the following substances defined as CMR 1A and/or CMR 1B and/or endocrine disrupting substances in concentration above 0.1% weight by weight:

- Cobalt; CAS No. 7440-48-4; EC No. 231-158-0

Current scientific evidence supports that medical devices manufactured from cobalt alloys or stainless steel alloys containing cobalt do not cause an increased risk of cancer or adverse reproductive effects.

Contamination

 The device must be used with sterile drapes. These drapes must be installed in accordance with the instructions detailed in this User Manual.

 Verify the setup of the sterile drapes before beginning a surgery to ensure the asepsis of the surgical field.

Use of the Application in Collaborative Mode

 Continue pressing the Foot Pedal when pinning or drilling in Collaborative mode to enable Bone Tracking mode, otherwise accuracy may be impacted. Visual and audio notifications are provided if the Foot Pedal is released in Collaborative mode.

Specific Warning for the United States of America

 **CAUTION:** Federal Law restricts this device to sale by or on the order of a physician.

3. Description

3.1 Overview

The ROSA Knee System is a robotic platform that aims at assisting orthopedic surgeons with the bony resections as well as assessing the state of the soft tissues to facilitate implant positioning during a total knee arthroplasty. Surgical planning software can be used pre-operatively by the surgeon to plan implant positioning and sizing. The surgeon may also use the imageless option within the ROSA Knee System to achieve the same goal as an image-based case.

The device is composed of two units, one positioned on each side of the operating table:

- Robotic Unit consisting of a compact Robotic Arm and a Touchscreen
- Optical Unit and a Touchscreen

The intra-operative workflow and surgical concepts implemented in the system remain close to the conventional TKA workflow. As such, at the time of the surgery and based on the surgical plan, the system mainly assists the surgeon for:

- Determining reference alignment axes in relation to anatomical landmarks
- Planning the orthopedic implant's location based on these reference alignment axes and orthopedic implant geometry
- Assisting in joint balancing
- Precisely positioning the Cut Guide relative to the planned orthopedic implant location by using a Robotic Arm



ROSA Knee System

3.2 Operating Principle

The operating principle for a total knee arthroplasty procedure is described below.

3.2.1 Case Information

The case is launched with a USB drive plugged into the Robotic Unit using the case management application. The welcome screen of the application confirms the patient ID, procedure laterality, implant family and instrumentation. Once the user has confirmed the information, the ROSA Knee application can be launched.

3.2.2 Pre-operative Planning

Image-based cases

The patient's knee, reconstructed in 3D using pre-operative X-rays or MRI, can be used for the preparation of a pre-operative plan. In this case, a patient-specific 3D bone model will be displayed on some panels.

 If the registration of the landmarks taken intra-operatively and the patient knee reconstructed in 3D is unsuccessful, the user will have the possibility to redo the landmarks or switch to an imageless case.

Imageless cases

If desired, the surgeon can decide not to plan the surgery prior to the surgery date and use the ROSA Knee System intra-operatively. In this case, generic bone schematics will be displayed in the user interface.

 If a Persona IQ[®] implant is used, please refer to the Pre-operative Planning section of the Persona IQ Surgical Technique (3640-US-en).

3.2.3 OR Setup

The patient is placed on the surgical table in supine position. The Robotic Unit is positioned approximately at the patient's hip and approximately 45° relative to the surgery table. Two patient bone references are installed on the patient's femur and tibia as a reference for leg movements. A third reference is located on the Robotic Unit (on the post of the ROSA Base Reference Bar closest to the surgical table) to track where the Robotic Unit is relative to the patient's leg during the surgery.

 During the surgery, the surgeon must always stay on the same side as the Robotic Unit.

 The maximum height of the patient on the OR table should be 44 inches to minimize tracker visibility problems. In case of a patient with a high BMI, lower the table to avoid visibility problems.

There are four possible OR setups:

- Operating on a right knee, with the surgeon on the same side as the operated knee
- Operating on a right knee, with the surgeon on the opposite side of the operated knee
- Operating on a left knee, with the surgeon on the same side as the operated knee
- Operating on a left knee, with the surgeon on the opposite side of the operated knee

Right Knee

Left Knee

Surgeon same side as the operated knee

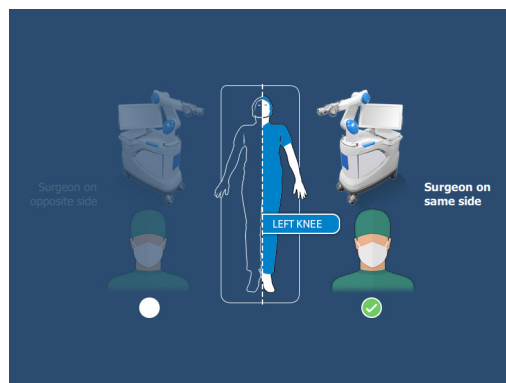
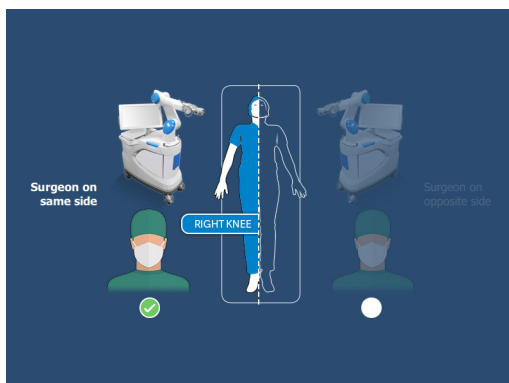

Surgeon opposite side of the operated knee

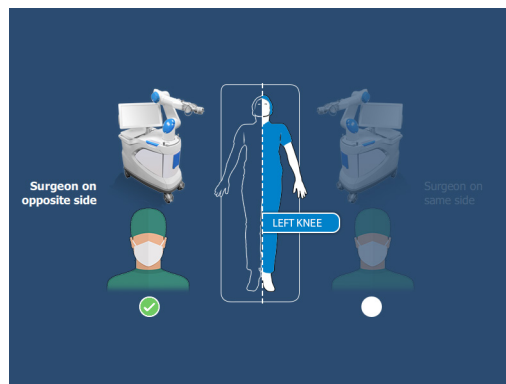
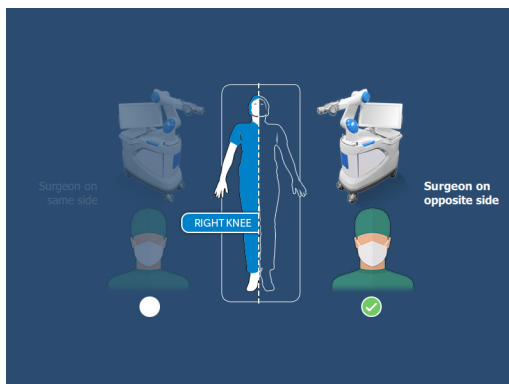

Possible OR Setups

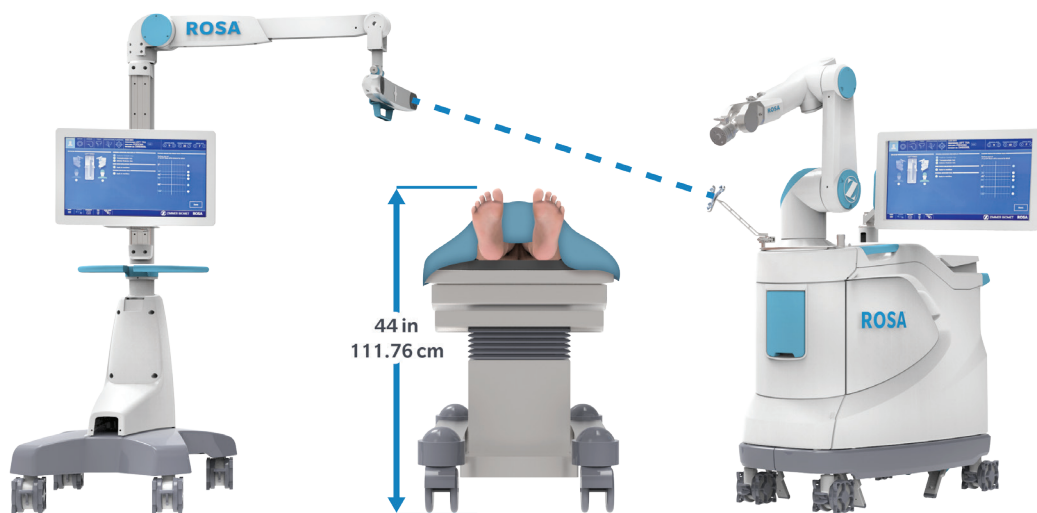

Maximum height of patient to minimize tracker visibility problems

3.2.4 Robotic Unit Registration

Registration of the Robotic Unit is performed with a fourth reference mounted on the Robotic Arm prior to the start of the surgery. This ensures the functional verification of the Robotic Arm prior to the start of the surgery. The patient should be in the OR for this step.

3.2.4 Robotic Unit Registration (cont.)



Risk of collision: When the Robotic Unit is in Automatic mode, stay clear of the Robotic Arm and its path to the next position.

3.2.5 Bony Landmarks & Navigation

Using a registration pointer, the surgeon will digitize the bony landmarks to record the patient leg coordinate system. The surgeon may also digitize the Checkpoint Screw (optional). Throughout the surgery, real-time tracking of patient movement is provided by the optical tracking system.

3.2.6 Planning

If not done pre-operatively, the surgeon can set his surgical plan intra-operatively, i.e. the femur and tibia bone cuts, according to preferences (including Personalized Alignment) and the chosen implant components.



If a Persona IQ implant is used, please refer to the Pre-operative Planning section of the Persona IQ Surgical Technique (3640-US-en).

3.2.7 Surgery

Based on the intra-operative planning values, the Robotic Arm will move to reach the appropriate positions to execute the bone resections.



Risk of collision: When the Robotic Unit is in Automatic mode, stay clear of the Robotic Arm and its path to the next position.

If the Femoral Rotation Assessment (optional) is selected, the ROSA Knee System provides clinical information to assist the surgeon in setting up the femoral rotation, taking into consideration the condition of the knee (medial and lateral gaps).

3.3 System Description

3.3.1 Robotic Unit

The Robotic Unit is composed of the following main components:

- Robotic Arm
- Touchscreen for operating the device
- Immobilization system
- Foot Pedal
- Computer and software

The Robotic Unit is equipped with swivel wheels and handles allowing the device to be easily moved from one operating room to the other by a single person. The wheels are equipped with foot pressure brakes to lock the unit in place and cable pushers to avoid rolling on cables.

It has optional lateral openings and a sliding shelf providing storage for various items. A fixed bar (ROSA Base Reference Bar) on the front side of the Robotic Unit is used to install the ROSA Base Reference Frame.

3.3.1 Robotic Unit (cont.)

The Robotic Unit is powered by the operating room power supply by plugging the power cable from the Rear Panel into a power plug compatible with the device characteristics.

The Foot Pedal is linked to the Robotic Unit by plugging the cable to the dedicated connector on the Rear Panel.

The Robotic Unit power cable and Foot Pedal cable can be rolled around rollers on the Rear Panel. The Foot Pedal may also be stored in the storage area.



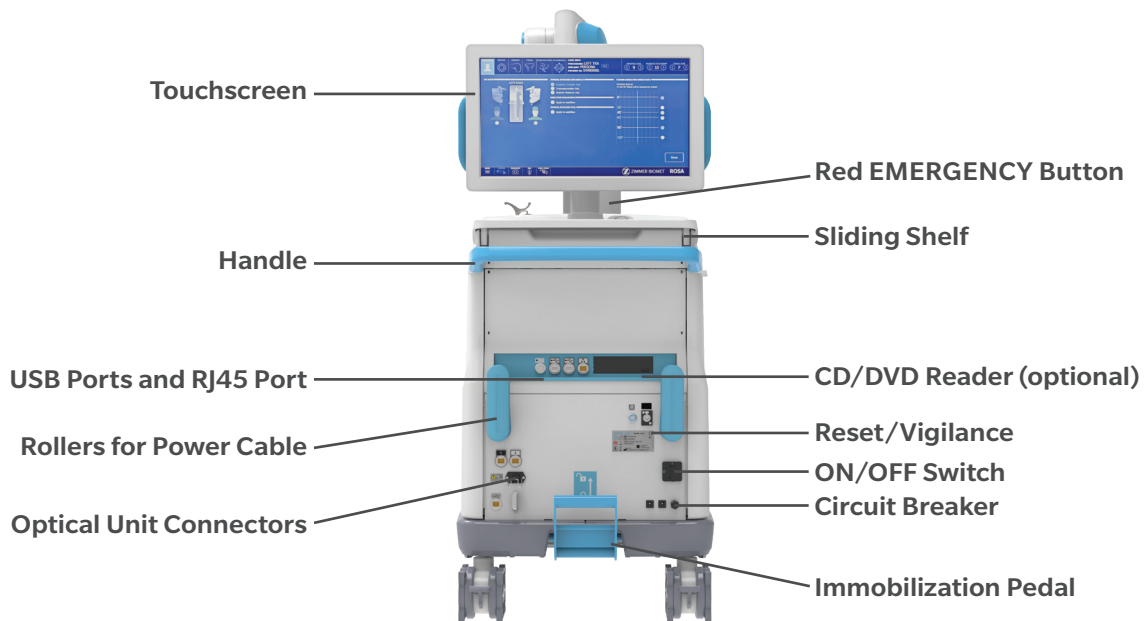

Rear Panel

3.3.1 Robotic Unit (cont.)

The Rear Panel includes:

- Main ON/OFF switch to turn on and off the device
- RESET button to restart the PC
- CIRCUIT BREAKER button to restart the device after it has been turned off to an overvoltage
- Connectors to plug in the Optical Unit and the Foot Pedal
- USB ports to import cases. CD/DVD reader is unplugged and non-functional. One USB port is available in the storage area beneath the sliding shelf to connect a mouse
- RJ45 port to connect the system to an intra-operative imaging system (deactivated)
- Controller servicing port (deactivated)
- Laser button (deactivated)

 Do not connect any other elements to the Robotic Unit than those provided with the device.

 In order to prevent accidental detachment of connectors, ensure the metallic ring is attached to the Robotic Unit's hook, if applicable.

 Make sure the metallic ring of the Optical Unit cable is attached to the hook on the Rear Panel of the Robotic Unit in order to ensure EMC protection, if applicable.

3.3.1.1 Robotic Arm

The Robotic Arm is equipped with a Force Sensor that manually moves the Robotic Unit to the desired location by measurement of forces exerted at the end of the arm and a compensation principle, regardless of the instrument used.



3.3.1.2 Touchscreen

The device includes two Touchscreens that display the user interface, one on the Robotic Unit and one on the Optical Unit.



3.3.1.3 Immobilization System



The Robotic Unit is equipped with a system immobilizing it to the ground. This system is composed of four stabilization feet, activated by a pedal. Two positions are available: the unit is immobilized when the pedal is down or the unit is mobile when the pedal is up. Additionally, each wheel of the Robotic Unit can be locked individually.



Pedal in down position immobilized



Pedal in up position mobile

-  Risk of pinching: Do not place fingers or feet under the stabilization feet before immobilization of the system.
-  Verify the position of the device and its environment when using the Robotic Unit immobilization system. Make sure cables or wires are cleared from the area of the stabilization feet to prevent damage.

3.3.1.4 Vigilance Device (Foot Pedal)

The device is equipped with a Foot Pedal that enables the Robotic Arm movements. The Robotic Arm will only move if the user presses the Foot Pedal. This operating principle applies to the SETUP and RESECTIONS panels. The Robotic Arm movement is interrupted as soon as the user releases the Foot Pedal.

The Foot Pedal is also used in the KNEE STATE EVALUATION panel to record varus/valgus and laxity of the knee. When the Foot Pedal is pressed, values will be recorded. When the Foot Pedal is released, live values will not be recorded.



Vigilance Device (Foot Pedal)

-  Ensure that the Foot Pedal is operating correctly before beginning a procedure. Visually inspect the device and perform a test for interruption/resumption of Robotic Arm movement.

3.3.2 Optical Unit

The Optical Unit is composed of:

- Optical Camera
- Camera Positioning Arm
- Touchscreen

 Risks generated by laser beam exposure: The device uses a laser integrated into the Optical Camera. This laser is of class 2 (power inferior to 1 W, eye protection by the palpebral reflex). Do not orient the laser beam to the eyes or to any light-reflecting surfaces (such as mirrors) to avoid any direct or indirect exposure to laser beam.

 Do not orient the laser towards the patient's eyes, the user's eyes or anyone else's eyes.

The Optical Unit is powered by the Robotic Unit by plugging the cable into the connector on the Robotic Unit Rear Panel. A roller is included to properly store the Optical Unit Cable. The Optical Unit is equipped with swivel wheels and a handle allowing the device to be easily moved from one operating room to the other by a single person. Each wheel has a brake and a cable pusher system. A laser is integrated into the camera to facilitate the camera positioning and orientation adjustments during the device installation in the operating room.

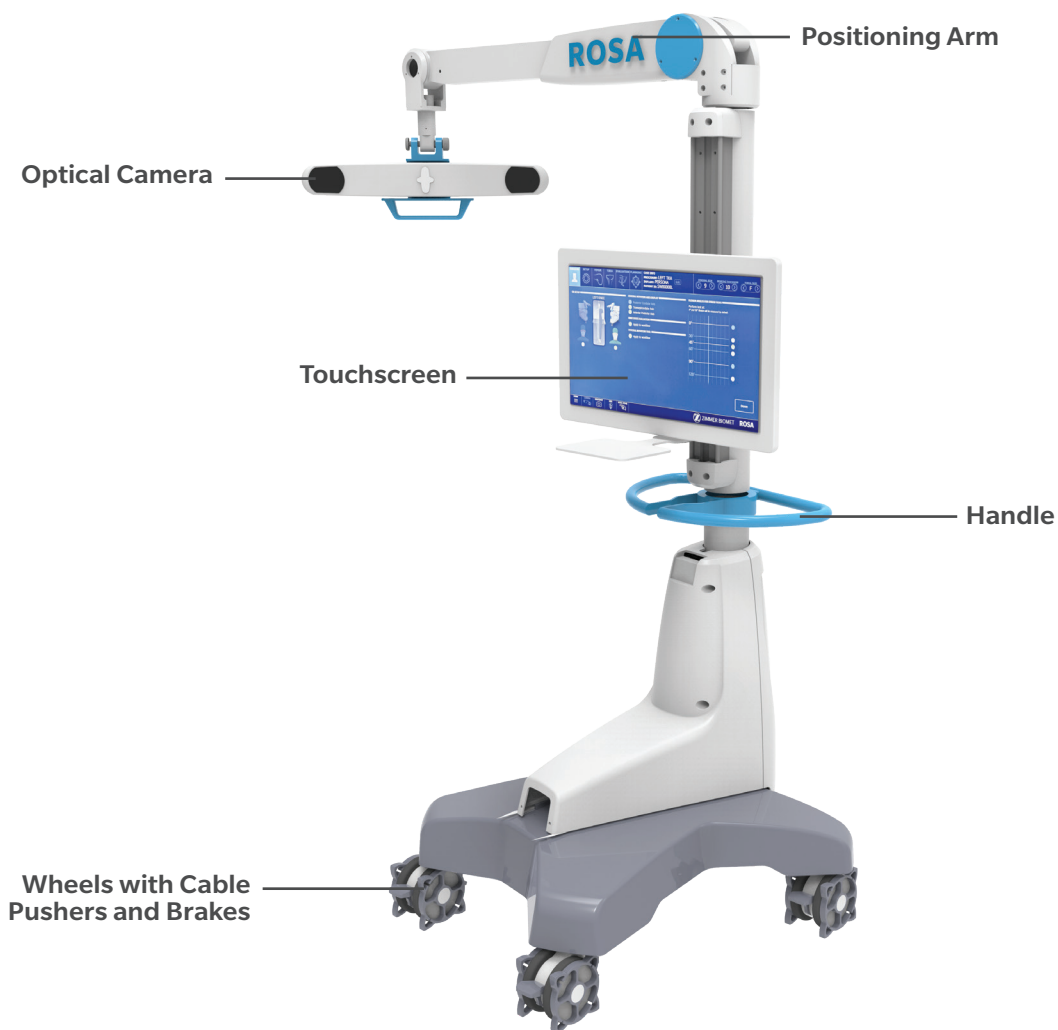

3.3.3 Instrumentation

ROSA Knee Instruments

All reusable instruments need to be sterilized before each use.

Component's Name	Part Number
Instrument Case Lid	110031221
3.5 mm Hex Head Screwdriver	00-5120-087-00
Universal Validation Tool Body	20-8000-010-06
Distal & Posterior Condyles Digitizer	20-8000-010-17
2 Pins Reference Femur TS3	20-8000-010-33
ROSA Tibia Reference A	20-8020-028-00
ROSA Tibia Reference B	20-8020-029-00
Offset 2 Pins Reference Right Tibia Size 6	20-8000-010-35
Offset 2 Pins Reference Left Tibia Size 6	20-8000-010-36
Navitracker Pliers	20-8000-070-05
ROSA Base Reference Frame	20-8020-002-00
ROSA Arm Instrument Interface	20-8020-004-00
ROSA Persona TKA Cut Guide A	20-8020-007-00
ROSA Persona TKA Cut Guide B	20-8020-008-00
ROSA NexGen TKA Cut Guide A	20-8020-009-00
ROSA NexGen TKA Cut Guide B	20-8020-010-00
ROSA Vanguard TKA Cut Guide A	20-8020-011-00
ROSA Vanguard TKA Cut Guide B	20-8020-012-00
ROSA Registration Pointer	20-8020-013-00
ROSA Arm Reference Frame	20-8020-015-00
ROSA Knee Persona Kit	20-8020-060-00
ROSA Knee Persona ID Plate	20-8020-060-01
ROSA Knee NexGen Kit	20-8020-061-00
ROSA Knee NexGen ID Plate	20-8020-061-01
ROSA Knee Vanguard Kit	20-8020-062-00
ROSA Knee Vanguard ID Plate	20-8020-062-01
Trocar Screw Pin Driver	00-5901-021-00
ROSA Knee Condyle Digitizer, Small	20-8020-190-00
ROSA Knee Condyle Digitizer, Medium	20-8020-191-00
ROSA Knee Condyle Digitizer, Large	20-8020-192-00
ROSA Knee Tibia Validation Tool	20-8020-193-00
ROSA® Knee Tray	20-8020-064-00
ROSA® Knee Instrument Case	20-8020-063-00
ROSA Knee General Instrument Case	20-8020-065-00
ROSA Knee Modular Instrument Case	20-8020-066-00
ROSA Modular Tray	20-8020-067-00
ROSA Pin Caddy	20-8020-068-01
ROSA TKA Cut Guide Bracket	20-8020-068-02
Universal Validation Tool Assembly Bracket	20-8020-068-03
Condyles Digitizer Bracket	20-8020-068-04
Generic Full 5" Base Assembly	00-5888-003-50
Blue Universal Case Lid	00-5967-018-00

3.3.3 Instrumentation (cont.)

Disposables

Component's Name	Part Number
Disposables for Bone References Installation	
Fixed Fluted Pin 3.2x150 mm (non-sterile)	20-8000-000-01
Fixed Fluted Pin 3.2x80 mm (non-sterile)	20-8000-000-02
Fixed Fluted Pin 3.2x150 mm	20-8000-000-10
Fixed Fluted Pin 3.2x80 mm	20-8000-000-11
Disposables for Pinning Cut Guides	
Trocar Tipped Drill Pin (2.5 mm hex) 3.2x75 mm (Persona)	00-5901-020-00
CAS 3.2 mm Headless Trocar Drill Pin	20-8000-000-16
Vanguard Quick Release Trocular Pin	32-486255
Vanguard Sterile Quick Release Drill Pin	32-486265
Disposables Checkpoint Screws	
ROSA Checkpoint Screw 13 mm, Non-Sterile	20-8020-194-00
ROSA Checkpoint Screw 15 mm, Non-Sterile	20-8020-195-00
ROSA Checkpoint Screw 17 mm, Non-Sterile	20-8020-196-00
ROSA Checkpoint Screw 13 mm, Sterile	20-8020-158-00
ROSA Checkpoint Screw 15 mm, Sterile	20-8020-159-00
ROSA Checkpoint Screw 17 mm, Sterile	20-8020-160-00
Other Disposables	
Navitracker Kit A: Knee	20-8000-000-07
ROSA Robotic Unit Drape	20-8020-080-00
ROSA Arm Drape	ROSAS00055
Monitor Drape	ROSAS00056
Zimmer Oscillating Saw Blade 1.27 mm	25090127AGC*
Zimmer Oscillating Saw Blade 1.37 mm	25090127AGC*

* If necessary, other hub styles are available

 Handle instruments with care. Avoid dropping instruments. Damage to an instrument can have a significant effect on the accuracy of the procedure and consequently, on the post-operative surgical outcome. At the end of the procedure, instruments are placed in their tray for sterilization.

3.3.3.1 ROSA Arm Instrument Interface

The ROSA Arm Instrument Interface is attached to the Robotic Arm in sterile conditions using three captive screws. It enables maintaining sterile conditions when changing tools. This part must be sterilized before each use.

 To avoid touching the non-sterile part of the Robotic Unit and to preserve sterility, always use the handles to hold the ROSA Arm Instrument Interface in place during installation.



3.3.3.2 ROSA Arm Reference Frame

The ROSA Arm Reference Frame is attached to the Robotic Arm interface with two captive screws. It is used during Robotic Unit registration prior to the start of the surgery. This part must be sterilized before each use.



3.3.3.3 ROSA Base Reference Frame

The ROSA Base Reference Frame is installed to the Robotic Unit over the ROSA Base Reference Bar, which is covered by a surgical drape using the post closest to the surgical table. It is a reference to follow the relative motions between the Robotic Unit and the Optical Camera. This part must be sterilized before each use.



 If the ROSA Base Reference Frame moves at any time during the procedure, the registration of the Robotic Arm has to be performed again (SETUP panel).

3.3.3.4 ROSA TKA Cut Guide

The ROSA TKA Cut Guide is attached to the ROSA Arm Instrument Interface with two captive screws. For each implant brand (Persona, NexGen, Vanguard), there are two instruments:



- A: When the Robotic Unit and the surgeon are on the left side of the patient regardless of the operated knee
- B: When the Robotic Unit and the surgeon are on the right side of the patient regardless of the operated knee

3.3.3.5 ROSA Registration Pointer

The ROSA Registration Pointer enables digitizing anatomical landmarks on which final results and accuracy depend. This part must be sterilized before each use.



 Care must be taken not to pierce through the cartilage with the ROSA Registration Pointer tip.

3.3.3.6 Universal Validation Tool Body

The Universal Validation Tool Body is used to validate the femoral distal resection. This part must be sterilized before each use.



 Verify that the NavitrackER device is installed on the correct side of the Universal Validation Tool Body.

3.3.3.7 Distal & Posterior Condyles Digitizer

When assembled with the Universal Validation Tool Body, the Distal & Posterior Condyles Digitizer is used to digitize the posterior condylar axis (PCA) and validate the tibial proximal resection. This part must be sterilized before each use.



3.3.3.8 ROSA Knee Condyle Digitizer Small/Medium/Large

When assembled with the Universal Validation Tool Body, the ROSA Knee Condyle Digitizer is used to digitize the posterior condylar axis (PCA). There are three sizes of Condyle Digitizer: Small, Medium, and Large. Size should be selected according to patient anatomy and surgeon preference.

The appropriate size will allow for the palpators to be in contact with the most prominent aspect of both posterior condyles. These instruments must be sterilized before each use.



3.3.3.8 ROSA Knee Condyle Digitizer Small/Medium/Large (cont.)

The ROSA Knee Condyle Digitizer, Medium (20-8020-191-00) is the same size as the Distal & Posterior Condyles Digitizer (20-8000-010-17)

3.3.3.9 ROSA Knee Tibia Validation Tool

When assembled with the Universal Validation Tool Body, the ROSA Knee Tibia Validation Tool is used to validate the tibial resection. This part must be sterilized before each use.



3.3.3.10 Patient References

3.3.3.10.1 Femoral Reference Frame

The Femoral Reference Frame on the patient's femur is used as a reference for monitoring the patient's motions. The reference is fixed outside the incision, using percutaneous pins through the vastus medialis in the femur, as proximal as possible, to stay clear of the working area. Alternatively, the Femoral Reference Frame can be installed within the incision. The pins should be set near-bicortically in the bone to ensure maximum stability. This part must be sterilized before each use.



Femoral Reference Frame

2 Pins Reference Femur TS3

3.3.3.10.2 ROSA Tibia Reference A/B P/N: 20-8020-028-00/20-8020-029-00

The Tibial Reference Frame on the patient's tibia is used as a reference for monitoring the patient's motions. It is fixed outside the incision, using percutaneous pins normal to the medial surface of the tibial diaphysis at approximately four fingers distal to the knee incision. Alternatively, the Tibial Reference Frame can also be installed inside the incision. The pins should be set near-bicortically in the bone to ensure maximum stability. This part must be sterilized before each use.



Tibial Reference B







Tibial Reference A

OR Setup

- A: When the Robotic Unit is on the left side of the patient regardless of the operated knee
- B: When the Robotic Unit is on the right side of the patient regardless of the operated knee

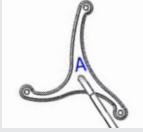
Insert pins through the pin holes marked L or R. For right legs, use pin holes labelled R, for left legs, use pin holes labelled L. Use the appropriate set screws corresponding to the pinholes through which the pins have been inserted to tighten the reference on pins.

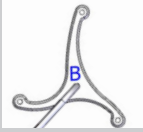
Insert pins through the appropriately marked holes according to the table below.

	Right Leg Operated	Left Leg Operated
Tibial Reference A 	Pins through R marking 	Pins through L marking 
Tibial Reference B 	Pins through R marking 	Pins through L marking 

3.3.3.10.3 Offset 2 Pins Reference Tibia P/N: 20-8000-010-35/20-8000-010-36

The Tibial Reference Frame on the patient's tibia is used as a reference for monitoring the patient's motions. It is fixed using percutaneous pins into the medial surface of the tibial diaphysis at approximately mid-tibia. The pins should be set bicortically in the bone to ensure maximum stability. This part must be sterilized before each use.





Tibial Reference Frame RT
Offset 2 Pins Reference Right Tibia Size 6









Tibial Reference Frame LT
Offset 2 Pins Reference Left Tibia Size 6

There is a RIGHT and a LEFT Offset 2 Pins Reference Tibia. OR setup determines whether to use RIGHT or LEFT:

- LEFT: When the robotic unit is on the left side of the patient, regardless of the operated knee
- RIGHT: When the robotic unit is on the right side of the patient, regardless of the operated knee

-  Before every surgery, the user must verify that all instruments have been sterilized.
-  Verify the integrity of all the instruments prior to each surgery. Visually inspect the instruments for damages such as cracks, burrs, sharp edges, deformation or a loose weld.
-  Make sure that the pins are not positioned close to the bone resection area. Placing the pins close to the bone resection area will increase the risk of breaking the pins with the cutting tools.

3.3.3.8 Patient References (cont.)

-  Verify the proper fixation of the percutaneous pins in the patient's bone anatomy (femur and tibia).
-  Verify the proper fixation of the patient references on the pins (femur and tibia). The femur and tibia references are secured on the pins, close to the patient's skin (without compression), using two hexagonal screws.
-  Bone references **MUST** be firmly attached to the bone and **MUST NOT** move at any moment during surgery. If a bone reference has moved, the landmarks digitized on that bone must be digitized again.
-  Be alert to the risk of causing damage to neurovascular structures, including femoral artery and vein or the popliteal artery and vein while installing the femoral patient reference.
-  Ensure that the pins are not placed in an area of interference with the tibial implant stem. Impact with the stem or broaching instruments can cause breakage of the pins as well as movement of the reference, which could result in inaccuracies.
-  Beware that muscle fibers may apply bending forces on the pins.

3.4 Instrumentation Assembly



The following instructions explain how to assemble ROSA Knee instruments.

-  Always verify the proper installation of an instrument to the Robotic Unit or Robotic Arm by making sure all screws are firmly tightened.

3.4.1 ROSA Arm Instrument Interface on the Robotic Arm

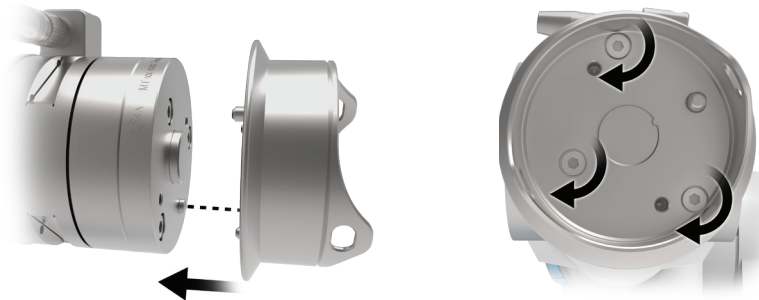
- Align the groove on the back of the ROSA Arm Instrument Interface (laser marked arrow on the side) with the peg of the electric insulator of the Robotic Arm (black dashed line).
- Assemble instruments together until the base of the ROSA Arm Instrument Interface is completely seated.
- Secure the ROSA Arm Instrument Interface by firmly tightening the three captive screws using a hexagonal screwdriver.



-  To avoid touching the non-sterile part of the Robotic Unit and to preserve sterility, always use the handles to hold the ROSA Arm Instrument Interface in place during installation.
-  Do not apply excessive torque on screws when installing an instrument. Do not use power tools.

3.4.2 ROSA Arm Reference Frame on the Robotic Arm

1. Align the groove of the ROSA Arm Reference Frame with the peg of the ROSA Arm Instrument Interface (black dashed line).
2. Assemble instruments together until the base of the ROSA Arm Reference Frame is completely seated.
3. Secure the ROSA Arm Reference Frame by firmly tightening the two captive screws by hand.

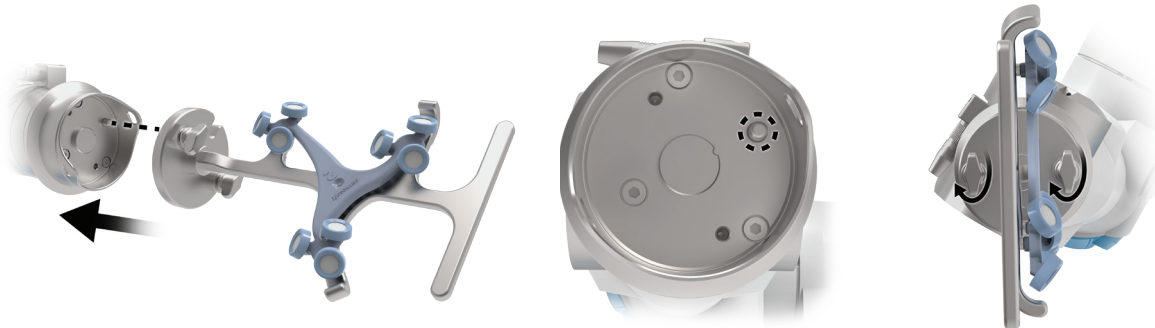

3.4.3 ROSA Base Reference Frame on the Robotic Unit

1. Open the clamp of the ROSA Base Reference Frame and align it on the post closest to the surgical table.
2. Assemble instruments together until the ROSA Base Reference Frame is completely seated vertically.
3. Close the clamp and bring the hand screw over the clamp.
4. Secure the ROSA Base Reference Frame by firmly tightening the screw by hand.
 - Instructions apply both for short and long ROSA Base Reference Frames.



3.4.4 ROSA TKA Cut Guide on the Robotic Arm

1. Align the groove of the ROSA TKA Cut Guide with the peg of the ROSA Arm Instrument Interface (black dashed line).
2. Assemble instruments together until the base of the ROSA TKA Cut Guide is completely seated.
3. Secure ROSA TKA Cut Guide by firmly tightening the two captive screws by hand.

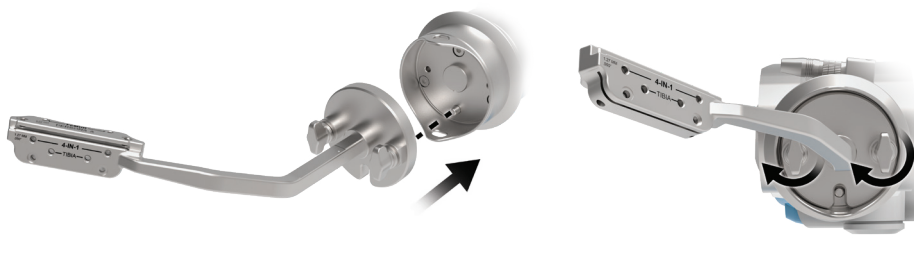

3.4.5 Universal Validation Tool Body and ROSA Knee Tibia Validation Tool (or Distal & Posterior Condyles Digitizer)

Tibial Proximal Resection Validation

- These two instruments need to be assembled together for the validation of the tibial proximal resection.
- Make sure both instruments are locked together using the lever.

 For the validation of the tibial proximal resection, make sure the Universal Validation Tool Body and ROSA Knee Tibia Validation Tool (or Distal & Posterior Condyle Digitizer) are locked together using the lever.

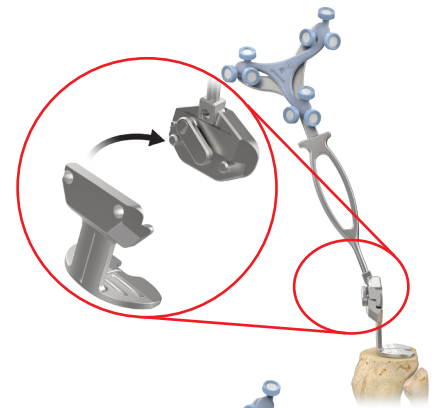

Femoral Distal Resection Validation

- Only the Universal Validation Tool Body is used for the validation of the femoral distal resection.
- Make sure to disconnect the Distal & Posterior Condyles Digitizer, ROSA Knee Condyle Digitizers or ROSA Knee Tibia Validation Tool from the Universal Validation Tool Body.

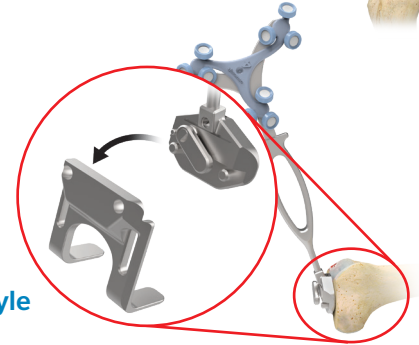

3.4.6 Universal Validation Tool Body and Condyle Digitizers (ROSA Knee Condyle Digitizer/Distal & Posterior Condyles Digitizer)

Posterior Condyle Digitization

- The Universal Validation Tool Body and one of the three available sizes (Small/Medium/Large) of the ROSA Knee Condyle Digitizer (or Distal & Posterior Condyles Digitizer) need to be assembled together for the digitization of the posterior condyles of the femur.
- Make sure both instruments are locked together using the lever.

 For the digitization of the posterior condyles of the femur, make sure the Universal Validation Tool Body and ROSA Knee Condyle Digitizer (or Distal & Posterior Condyles Digitizer) are locked together using the lever.

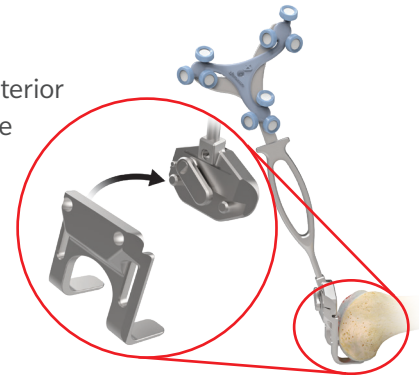

3.5 Disposables

3.5.1 Reflective Trackers (NavitrackER) Installation

The NavitrackER devices must be installed on each instrument used for optical tracking. To facilitate the installation of the trackers on the instruments, push the marker on each mounting stud using the NavitrackER pliers until it is fully seated.

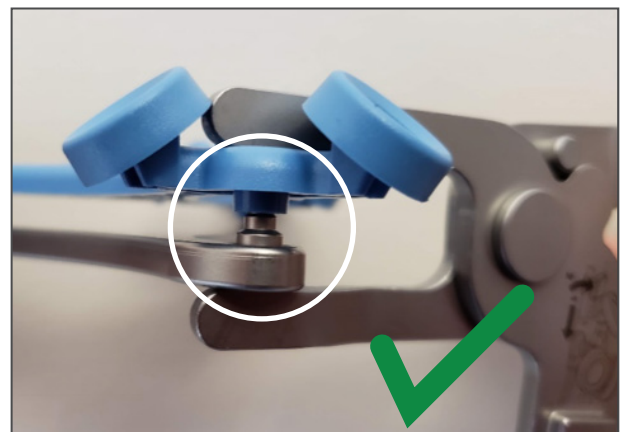
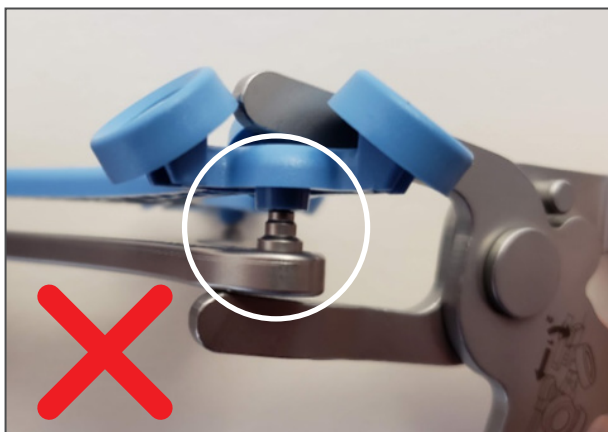

3.5.1 Reflective Trackers (NavitrackerER) Installation (cont.)

A click should be heard. It is important to verify that the NavitrackerER devices remain clean throughout the surgery (refer to NavitrackerER Instructions for Use).

The Universal Validation Tool Body is laser marked either RIGHT or LEFT.

Installation of NavitrackerER on the Correct Side of the Universal Validation Tool Body:

- LEFT Side: When the robotic unit is on the left side of the patient, regardless of the operated knee
- RIGHT Side: When the robotic unit is on the right side of the patient, regardless of the operated knee

 Always use NavitrackerER pliers for the installation. Ensure that reflective NavitrackerER devices are fully seated.

 Verify the proper fixation of the NavitrackerER devices on each instrument (ROSA Base & Arm Reference Frame, ROSA Registration Pointer, Tibial & Femoral Reference Frame and Universal Validation Tool Body). Always use the NavitrackerER pliers for installation.

 Always minimize handling of the NavitrackerER devices, since errors may result from the non-uniform reflection of their surface.

 Always use unblemished trackers.

 Each NavitrackerER device is single use and should not be resterilized to be reused in surgery.

The NavitrackerER devices must be installed on all used instruments for optical tracking using the NavitrackerER pliers. Push the marker onto the mounting studs until it is fully seated. It is important to verify that the NavitrackerER devices remain clean throughout the surgery.

 The use of optical trackers other than those provided by Zimmer Biomet may lead to loss of accuracy.

#2 ROSA Arm Reference Frame



#6 Tibia Reference Frame



#3 Femur Reference Frame



#7 ROSA Registration Pointer



#4 Universal Validation Tool Body



#9 ROSA Base Reference Frame



3.5.2 Pins

Fixed fluted pins (sterile and non-sterile) can be used to fix the bone references. The diameter is 3.2 mm and has a length of 80 mm or 150 mm. Refer to section 3.3.3. for pins for the Cut Guides.



Pins are single-use hardware and should not be resterilized to be reused in surgery.

3.5.3 ROSA Checkpoint Screws

The ROSA Checkpoint Screws can be installed in the femur and tibia to verify stability of the Bone References throughout the surgery.



ROSA Checkpoints Screws are single-use hardware and should not be resterilized to be reused in surgery.

3.5.4 Drapes

Drapes for the Robotic Unit and Touchscreens are required prior to starting the surgery.



Never use a torn drape (Robotic Arm or base). In case of a tear or in doubt that the sterility is compromised, discard the drape and use a new one.



Never use damaged tape for taping the ROSA Arm Drape to the ROSA Arm Instrument Interface at the end of the Robotic Arm.

4. Installation

4.1 Warnings and Cautions About Robotic Unit Installation

 Ensure that the Robotic Unit is not moved once the immobilization system is locked.

Risks of pinching:

-  • Do not place fingers in accessible parts of the plastic covers of the Robotic Arm.
• Do not place fingers or feet under the stabilization feet before immobilization of the system.

 In order to avoid any risk of electric shock, the device must only be connected to an electric power network equipped with grounding. Device is class I, type BF.

 Do not simultaneously touch the patient and any component of the device other than those attached to the electrical isolation interface part.

 Ensure that the Foot Pedal is operating correctly before beginning a procedure. Visually inspect the device and perform a test for interruption/resumption of Robotic Arm movement.

 The operating table must not be moved once an instrument guided by the Robotic Unit is inserted into the patient anatomy.

Risks generated by laser beam exposure: the device uses a laser integrated into the Optical Camera.

 This laser is of class 2 (power inferior to 1 mW, eye protection by the palpebral reflex). Do not orient the laser beam to the eyes or to any light-reflecting surfaces (such as mirrors) to avoid any direct or indirect exposure to laser beam.

 Verify the position of the device and its environment when using the Robotic Unit immobilization system.

 During transportation, the device can be immobilized by activating the immobilization pedal. Do not install the device on an inclined surface, unless its stability is guaranteed.

 IPX0 Protection: Device without special protection against the penetration of liquids. Do not pour any liquids over the device.

 Do not connect any other elements to the Robotic Unit than those provided with the device.

4.2 Device Start Up

Switching the device ON:

1. Place the Robotic Unit on one side of the operating table and the Optical Unit on the opposite side. Plug the Optical Unit into the Robotic Unit.
 - For Configuration 1 Only: Plug the white and black cables into the corresponding white and black ports.
 - For Configuration 2 Only: Plug the USB, Ethernet, Jack and VGA cables into the corresponding ports.
 - For Configuration 3 Only: Plug the single connector into its socket and secure the connection.
2. Plug the power supply cable into a power source of appropriate voltage.
3. For Configuration 1 and 2 Only: Attach the metallic ring of the Optical Unit cable to the hook on the Robotic Unit Rear Panel. Lock the connector in place using the metallic clip.
4. Switch the robot ON.
 - Allow the camera to warm up for few minutes.



In order to prevent accidental detachment of connectors, ensure the metallic ring is attached to the Robotic Unit's hook and lock the connector in place using the metallic clip, if applicable.



Make sure the metallic ring of the Optical Unit cable is attached to the hook on the Rear Panel of the Robotic Unit in order to ensure EMC protection, if applicable.



If the screen remains black at start up: Check that the touchscreen is powered ON (button on the right side of the screen) and/or restart the computer by pushing the button located on the rear panel of the device.



To restart the device, wait at least 10 seconds after shutting down and for the RESTART button light to turn off before powering back on.

4.3 Camera Errors

4.3.1 Camera Temperature is Too Low/High

When launching the application, if the camera temperature is out of range, a notification will be displayed.

1. Wait for the camera to adjust to room temperature.
2. Click RESUME to continue.

4.3.2 Camera was Bumped

When launching the application, if the camera was bumped during storage or transportation, a notification will be displayed.

1. Revert to standard instrumentation (section 4.5).
2. Please contact Customer Service.

4.4 Emergency Procedure

In case of device failure or an emergency requiring a fast removal of the device to access the patient, it is recommended to follow one of the procedures described below. The user may choose to move the device away from the operating table partially or completely, depending on the procedure that is needed to cope with the device failure or emergency.

Partial Removal–Moving the Robotic Arm Away

1. Remove any instruments that are linking the patient to the Robotic Unit.
2. Send the Robotic Arm to the ROSA HOME position to free space around the patient's knee.

This procedure can be performed by one sterile operator.

Full Removal–Moving the Robotic Unit Away

1. Remove any instruments that are linking the patient to the Robotic Unit.
2. Deactivate the Robotic Unit immobilization system (one main pedal and four wheels).
3. Move the Robotic Unit away to free up space around the patient.
4. If necessary, move the Optical Unit away after releasing the wheels, brakes.
5. If necessary, remove the patient's bone references (femur and tibia).
6. After a full removal of the Robotic Unit, revert to standard instrumentation.

This procedure requires one sterile operator and one non-sterile operator.



If there was a full removal of the Robotic Unit, if bone references were removed or if there was a problem with ROSA Knee instrumentation that could lead to inaccuracy, the surgeon must revert back to standard instrumentation.

Any serious incident related to the device should be reported to the manufacturer and the competent authority of the Member State by the user and/or patient.

4.5 Reverting to Standard Instrumentation

A full set of the implant system's standard instrumentation is needed to perform a surgery in conjunction with the ROSA Knee System in case the ROSA Knee System cannot be used. It is mandatory to revert to standard instrumentation in case of:

- Full removal of the Robotic Unit.
- Problem with the ROSA Knee instrumentation that could lead to inaccuracy.

For any other problem encountered at any time during the surgical flow, it is always possible to revert to standard instrumentation. For example, if the pin/drill holes were already performed with the ROSA TKA Cut Guides, these holes can be reused with their respective standard Cut Guide counterpart (e.g. ROSA Persona TKA Cut Guide A (20-8020-007-00) can be reused with a standard Persona 0 Degree Distal Femoral Cut Guide (42-5099-010-00)).

4.6 Case Management Application

4.6.1 Case Management Application–Interface Overview



Case Management Application Functions

SYNC: This function decrypts the case(s) from a USB drive and syncs them with the ROSA Clinical Computer.

CASES: This function lists the cases that were uploaded using the SYNC function. When selecting a case, a PIN will be required to load the case and launch the welcome screen of the ROSA Surgery application.

LOGOUT: This function exits the case management application and should only be used by authorized personnel to access the Maintenance mode.

SHUTDOWN: This function shuts down the system.

4.6.2 Starting a Case

The case management application will start upon powering up the system.

1. Insert a USB drive containing the encrypted case(s) in a USB port.
2. Use the SYNC function to upload the case(s) to the ROSA Clinical Computer.
3. Use the CASES function to search for the case to be launched (at least three letters).
4. Select the appropriate case and click Launch.
5. Type in the PIN for the selected case.

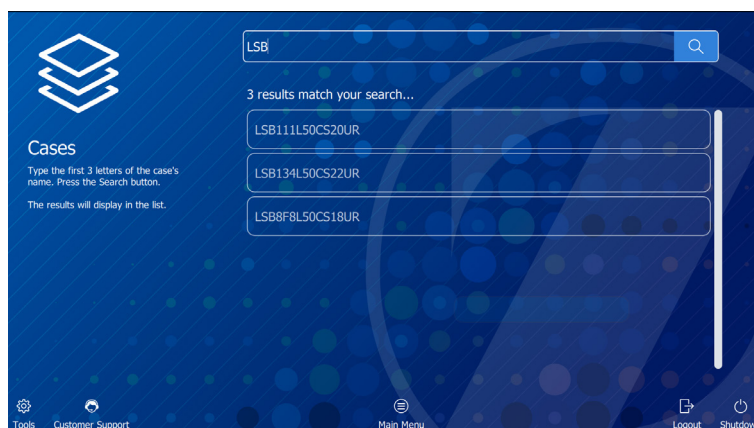

5. Intra-operative Guide/ Surgery



ROSA Knee Application: Welcome Screen

5.1 Welcome Screen

Upon launching a case, a welcome screen will appear where the user can confirm the patient ID, procedure laterality, implant family and instrumentation. Once the user has confirmed that the information is correct, the ROSA Knee application can be launched. If the information is incorrect, the user can quit and relaunch the correct case.

5.2 ROSA Knee Application–User Interface Overview



ROSA Knee Application User Interface

The ROSA Knee User Interface consists of a main panel and two task bars on the top and bottom of the screen. The task bars contain features that may be accessible in more than one panel.

5.2.1 Top Task Bar

5.2.1.1 Panel Buttons

The panel buttons allow direct access to a specific panel. An icon featuring a blue background indicates the currently active panel. Icons featuring white outlines indicate that the panel(s) are directly accessible. Greyed out icons indicate that these panels are not yet accessible. Inaccessible panels will become accessible once all necessary preceding tasks have been completed. The number and order of the displayed icons depend on preferences defined in the SURGEON panel.

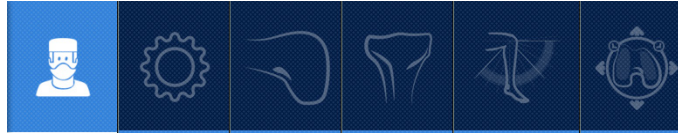

Panel Buttons

Panel		Mandatory	Optional
SURGEON		✓	
SETUP		✓	
FEMUR		✓	
TIBIA		✓	
EVALUATION			✓
PLANNING		✓	
RESECTIONS Drawer:	• Femoral distal resection	✓	
	• Tibial proximal resection	✓	
	• Femoral rotation tool		✓
	• 4-in-1 resections	✓	

5.2.1.2 Case Information

The case information displays the following details:

- Procedure laterality
- Implant editor (brand, femoral and tibial implant, instrumentation)
- Patient ID

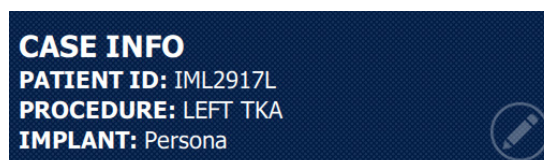

Case Information

5.2.1.2 Case Information (cont.)

Implant component sizes are displayed directly on the user interface. All supported implants are shown in Appendix A. Implant compatibility can be found in Appendices B and C.

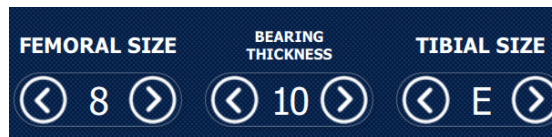

Implant Selector

 The implant related information can only be modified in the PLANNING panel and in the implant confirmation window.

5.2.2 Bottom Task Bar



Bottom Task Bar

5.2.2.1 Menu

The MENU button consists of:

- Language: Change User Interface language
- About: Information about the ROSA Knee application
- Customer Support: Customer service details
- Volume: Adjustment of the volume of all sounds of the ROSA Knee application
- Quit Application: Quit with an option to send the Robotic Arm to PARK position

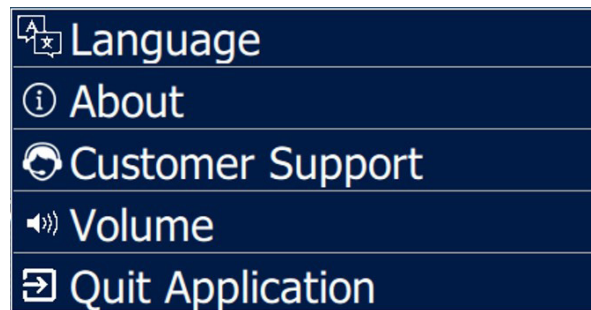

Menu

The MENU button is accessible at all times during the procedure.

5.2.2.2 Camera

The CAMERA button displays the volume viewer, which shows the top view (left side) and frontal view (right side) of the camera volume. By default, only the NavitrackERs that are needed at the current step of the workflow are displayed. The ALL NAVITRACKERS button will display all visible NavitrackERs. The CAMERA button is accessible at all times during the procedure.

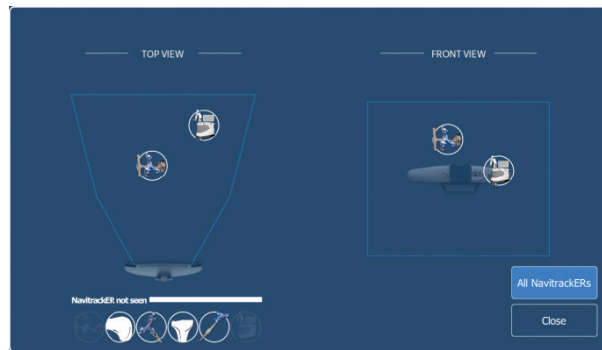

Camera Volume Viewer

 The camera can be slightly repositioned at any time in order to have the necessary NavitrackER devices visible, except during the acquisition of the femoral head center and in Bone Tracking Mode. During bone resections, the camera needs to stay in a volume close to where the registration was initially performed.

5.2.2.3 Snapshot

The SNAPSHOT button saves a capture of the screen. The SNAPSHOT button is accessible at all times during the procedure. Snapshots can be downloaded along with the Surgeon Report.

5.2.2.4 HKA

The HIP-KNEE-ANKLE (HKA) button displays the pre-operative leg alignment and compares it to the currently planned HKA. The HKA button is accessible at all times during the procedure. The pre-operative HKA is only available for image-based cases.

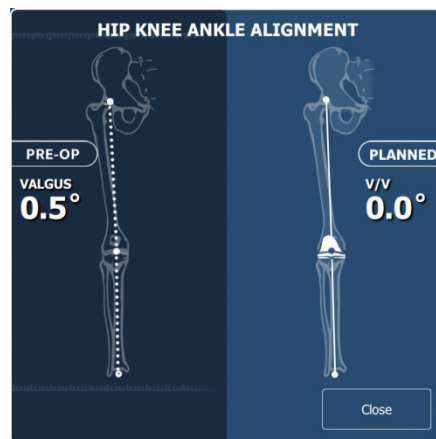

HKA Window

5.2.2.5 Bone Reference Checkpoint (optional)

The Bone Reference Checkpoint is an optional feature allowing the surgeon to verify that the Bone References have not moved since landmarking.

ROSA Checkpoint Screws are installed during landmarking and the ROSA Registration Pointer is used to acquire the divot on the femur and tibia Checkpoint Screws.

5.2.2.5 Bone Reference Checkpoint (optional) (cont.)

If the Bone Reference Checkpoint fails, the associated Bone Reference may have moved and accuracy of the system may be affected. The user will be prompted to verify stability of the ROSA Checkpoint Screw, the Bone Reference and the NavitrackerER, and retake landmarks before resections.

The BONE REFERENCE CHECKPOINT button is accessible at all times during the procedure.

5.3 Robotic Modes

Three robotic modes are programmed to dictate the behavior of the Robotic Arm at two distinct steps: registration (SETUP panel) and bone resections (RESECTIONS drawer). To trigger any motion of the robotic arm, the Foot Pedal must be pressed. The interface indicates the current mode with a color border around the main panel.

Automatic Mode (Orange border)

- The Robotic Arm will move to a pre-determined position

Collaborative Mode (Green border)

- The Robotic Arm will move if the surgeon applies a gentle force to the end of the Robotic Arm to move it to a desired position
- The Robotic Arm will move at a slow speed when it nears the bone
- During resections, the Collaborative mode is coupled with bone tracking. If the bone moves as the surgeon is moving the Cut Guide, it will stay on plane and track the bone position. This is Collaborative mode with Bone Tracking

Stationary Mode (Grey border)

- The Robotic Arm will not move

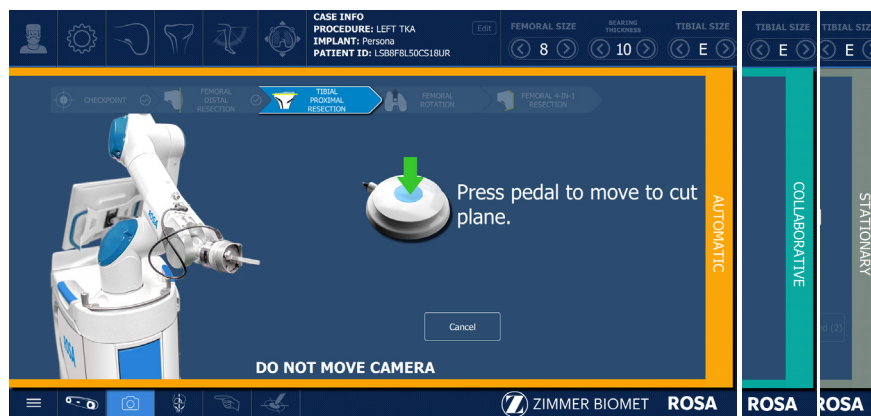

5.4 Robotic Positions

At various points during the ROSA Knee System surgical flow, the Robot Arm is sent to a defined position:

- HOME position:
 - Goes to this position after successful registration and remains there until resections
 - ROSA Knee TKA Cut Guide is installed in this position
 - Goes to this position when the ROSA HOME button is selected
- PARK position:
 - Position for transportation and storage
 - When the robot is turned on, the Robotic Arm will be in PARK position
 - Upon quitting the application after surgery and after undrapping the robot, the Robotic Arm will be sent to PARK position for shut down

5.5 Application Audio Notifications

The application has distinct audio notifications for the following situations:

- Robotic Arm in Automatic mode and moving to a predetermined location
- Robotic Arm in Bone Tracking mode and tracker is hidden or pedal not pressed
- Successful landmark acquisition
- Major or minor notification
- Snapshot of the current screen

5.6 Application Visual Notifications

Foot Pedal

- Press and hold the Foot Pedal to move the Robotic Arm or acquire Knee State Evaluation
- Further direction on the screen will describe the current action



Continue pressing the Foot Pedal when pinning or drilling in Collaborative mode to enable Bone Tracking mode, otherwise accuracy may be impacted. Visual and audio notifications are provided if the Foot Pedal is released during Collaborative mode with Bone Tracking.

Movement Needed

- During landmarking, a movement is needed to start the acquisition. The movement is needed for:
Femur: Femoral head center acquisition
Instruments: ROSA Registration Pointer and Universal Validation Body Tool

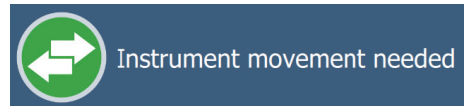
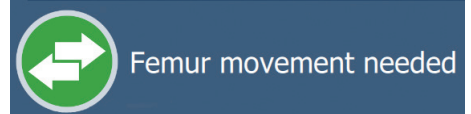

Landmark Acquisition Points

Landmark acquisition will display recommended locations with three colors:

- **White:** Upcoming landmark to be registered
- **Yellow:** Current landmark to be registered
- **Green:** Landmark successfully registered

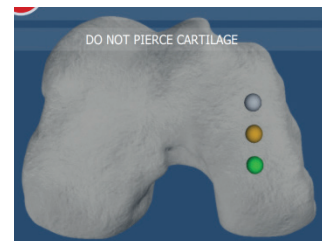

Point Too Close

- During landmarking, an acquisition point is too close to the previous points and was not recorded. Move away and stabilize again for a successful acquisition

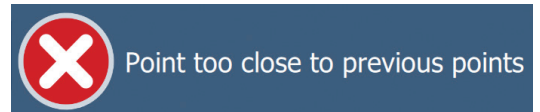

Outside Target Area

- During landmarking of the anterior cortex, an acquisition point was outside the dashed target area displayed on the user interface. Move inside the target area and stabilize again for a successful acquisition

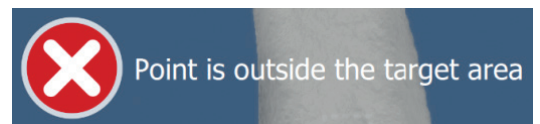

Wrong Laterality

- During landmarking, an acquisition point was taken on the wrong side of the bone (medial vs lateral). Reacquire the point on the correct side

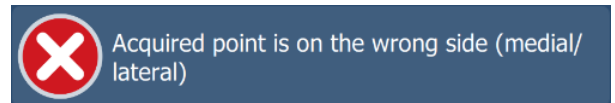

5.6 Application Visual Notifications (cont.)

NavitrackER Not Seen

- A NavitrackER is not visible by the camera. Either something is blocking the view or the camera needs to be readjusted

An icon will be shown for the following:

Instruments: ROSA Registration Pointer
 ROSA Arm Reference Frame
 ROSA Base Reference Frame
 Universal Validation Body Tool

References: Femoral tracker
 Tibial tracker

Notification

NavitrackER not seen

Instrument Icons



Reference Icons



The camera can be slightly repositioned at any time in order to have the necessary NavitrackER devices visible, except during the acquisition of the femoral head center and in bone tracking. During bone resections, the camera needs to stay in a volume close to where the registration was initially performed.

5.7 ROSA Knee Application–SURGEON Panel

In the SURGEON panel, the user can select preferences for certain intra-operative parameters. Preferences are classified into the following categories:

- Femoral Rotation Axis Display
- Knee State Evaluation
- Femoral Rotation Tool
- Flexion Angles for Stress Tests
- Bone Reference Checkpoint

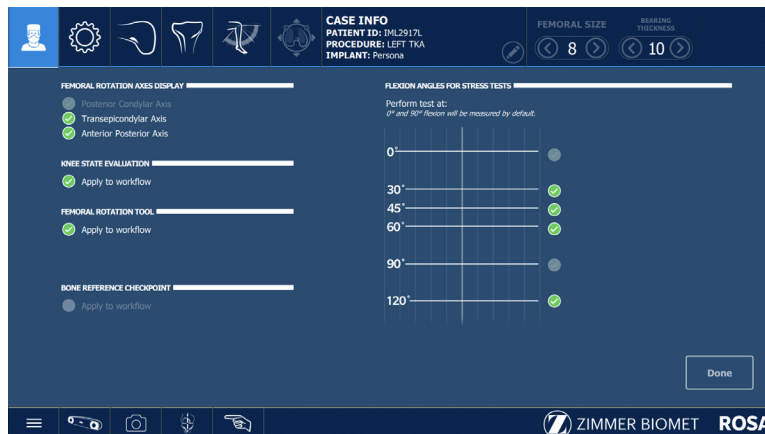

SURGEON Panel

5.7 ROSA Knee Application–SURGEON Panel (cont.)

A green checkmark means the option is selected. Depending on the preferences, different surgical steps will become active (e.g. EVALUATION panel and Femoral Rotation Tool in the RESECTIONS drawer).

- Click DONE when all preferences have been chosen to proceed to the SETUP panel.

5.7.1 Femoral Rotation Axis Display

The ROSA Knee System can display different femoral rotation axes in the PLANNING panel, based on surgeon preferences:

- Posterior Condylar Axis (PCA)
- Transepicondylar Axis (TEA)
- Anterior Posterior Axis (AP)

By default, the PCA cannot be unselected and will always be displayed.

5.7.2 Knee State Evaluation

The Knee State Evaluation provides quantitative information about soft tissue and range of motion as the surgeon proceeds with a stress test of the patient’s knee:

- Minimum, maximum and current flexion angle (degrees)
- Minimum, maximum and current varus/valgus angle (degrees) at various flexion angles
- Laxity in flexion and extension (mm)

If the Knee State Evaluation is selected by clicking “Apply to Workflow,” the EVALUATION button will appear in the panel buttons and will allow the surgeon to perform the stress test at different stages of the procedure (Initial, Intra-Op and Final). Conversely, if not selected, the EVALUATION button will not appear in the panel buttons and no values will be recorded by the ROSA Knee System.

5.7.3 Femoral Rotation Tool

The Femoral Rotation Tool provides quantitative information about ligament laxity (mm in flexion and extension) when the surgeon proceeds with a pull test (manually or with instruments such as a laminar spreader or Zimmer FuZion®). Femoral rotation values will be displayed and can be captured to be applied to the surgical plan.

If the Femoral Rotation Tool is selected by clicking “Apply to Workflow,” a FEMORAL ROTATION button will appear in the RESECTIONS drawer that will allow the surgeon to evaluate the gaps in extension and the femoral rotation of the implant following a pull test. Conversely, if not selected, the FEMORAL ROTATION button will not appear on the surgery workflow and no values will be recorded by the ROSA Knee System.

5.7.4 Flexion Angles for Stress Tests

This option enables the activation of recording varus/valgus at 30°, 45°, 60° and 120° of flexion in the EVALUATION panel. By default, 0° and 90° cannot be unselected and will always be displayed.

5.7.5 Bone Reference Checkpoint

If the Bone Reference Checkpoint feature is enabled by clicking “Apply to Workflow,” the surgeon will be requested to acquire the position of the ROSA Bone Screws placed in the femur and tibia during the initial landmark acquisition. The BONE REFERENCE CHECKPOINT button on the bottom bar will become activated. The user will also be prompted to verify Checkpoint position before resections.

Conversely, if not selected, the Bone Reference BONE REFERENCE CHECKPOINT button will not appear in the bottom bar, no checkpoint landmark will have to be acquired and the verification will not be requested of the user before resections.

6. ROSA Knee Application- SETUP Panel

6.1 OR Setup

During a ROSA Knee procedure, it is mandatory for the surgeon to stand on the same side as the Robotic Unit with the Optical Unit on the opposite side.

- The ROSA Knee application will automatically display the operated knee in the OR Setup section (right of left knee).
- The user must then select between two configurations:
 1. Surgeon on same side as operated knee
 2. Surgeon on opposite side of operated knee

! The surgeon is always on the same side as the Robotic Unit.

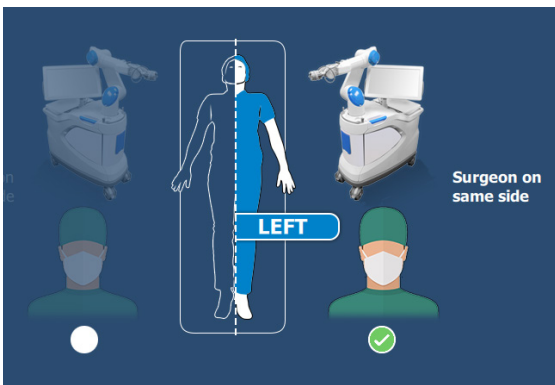

1

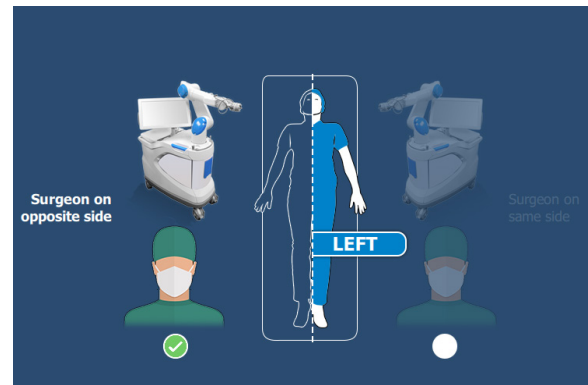

2

6.2 Calibration of Sensor

Move the Robotic Arm to Draping Position

1. In the SETUP panel, press and hold the Foot Pedal to move the Robotic Arm to DRAPING position.

Install the ROSA Arm Instrument Interface

1. Once the Robotic Arm is in DRAPING position, install the ROSA Arm Instrument Interface by firmly tightening the three captive screws using the hexagonal screwdriver.
2. Click NEXT to proceed to the calibration of the Force Sensor.

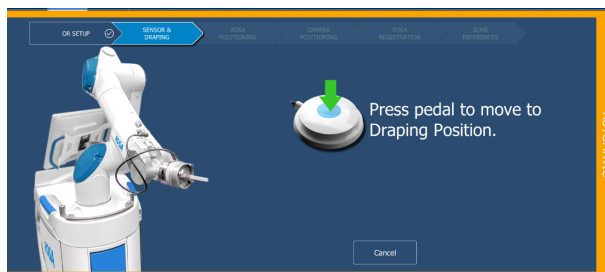

6.2 Calibration of Sensor (cont.)

- ⚠ Do not apply excessive torque on screws when installing an instrument.
Do not use power tools.

Calibrate the Force Sensor

1. Acknowledge the Robotic Arm is free of any force (checkmarks) and click YES.
 - If unsuccessful, redo calibration
 - If successful, click NEXT to proceed to draping



- ⚠ Do not touch the Robotic Arm. Only the ROSA Arm Instrument Interface should be installed on the Robotic Arm.

6.3 Draping

ROSA Knee can be draped using the ROSA Robotic Unit Drape or the ROSA Arm Drape combined with a standard surgical base drape.

- If using the ROSA Robotic Unit Drape, refer to the section below labeled: Install ROSA Robotic Unit Drape
- If using the ROSA Arm Drape combined with a standard surgical base drape, refer to the section below labeled: Drape the Robotic Arm and Robotic Unit

Install ROSA Robotic Unit Drape

The ROSA Robotic Unit Drape box of 20 part number is: 20-8020-080-00.
The ROSA Robotic Unit Drape single unit part number is: 20-8020-080-01.

1. With the help of a non-sterile user, drape the Robotic Unit by following the instructions on the application user interface and in the IFU provided with the drape.
2. Install the blue elastic at the end of the sterile drape on the ROSA Arm Instrument Interface, ensuring the elastic does not go beyond the end of the ROSA Arm Instrument Interface.
3. Ensure the blue stripe on the ROSA Robotic Unit Drape is aligned on top of the Robotic Arm.
4. Ensure the blue circle stickers are aligned with the elbow joint of the Robotic Arm.
5. Ensure the green square stickers are aligned with the posts of the ROSA Base Reference bar.
6. Click DONE when the draping is complete.







Drape the Robotic Arm and Robotic Unit

1. Cut the tip of the drape 4.75" (120 mm) from the end as indicated.
2. With the help of a non-sterile user, drape the Robotic Arm until the cut end is over the ROSA Arm Instrument Interface.
3. Tape to seal the drape around the complete circumference of the ROSA Arm Instrument Interface.
4. Install a standard surgical drape around the front and sides of the Robotic Unit base, over the Robotic Arm drape and around the lowest joint of the Robotic Arm.
5. Click DONE when draping is complete.



- ⚠ Ensure the ROSA Arm drape is not installed too tightly to allow the Robotic Arm to move freely without pulling on it.

- ⚠ Verify the setup of the sterile drapes before beginning a surgery to ensure the asepsis of the surgical field.

-  The sterile drape extremity (cut end or elastic) should not go beyond the end of the ROSA Arm Instrument Interface.
-  The tape must adhere to both the drape and the ROSA Arm Instrument Interface.
-  The base drape must be installed over the arm drape and around the lowest joint of the Robotic Arm.
-  Ensure that no excessive force is applied to the Force and Torque Sensor cable when installing and removing the drape.

6.4 Touchscreen Monitor Draping

1. Slide the monitor drape over the screen from top to bottom.
2. Fully unfold the drape over the screen.
3. Cover the mouse and its support with the lower part of the drape (if draping the Optical Unit Monitor).
4. Stretch the drape around the screen and tape it at the back of the screen.



6.5 ROSA Knee Positioning

1. Install the ROSA Base Reference Frame on the ROSA Base Reference Bar over the draping on the post closest to the surgical table.
2. Install the ROSA Arm Reference Frame on the ROSA Arm Instrument Interface by firmly tightening the two captive screws by hand.
3. Click NEXT when both instruments are installed.

-  Verify the ROSA Arm drape is not pulled too tightly before installing the base reference, to allow the Robotic Arm to move freely.

4. Click NEXT to proceed to the setup and registration.

-  The ROSA Base Reference Frame should never move during surgery.

Move the Robotic Arm to Setup Position

1. Press and hold the Foot Pedal to move the Robotic Arm to the SETUP position.

-  Risk of collision: When the Robotic Unit is in Automatic mode, stay clear of the Robotic Arm and its path to the next position.

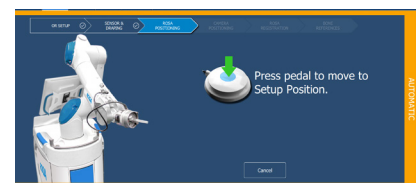



Position the Robotic Unit

1. Align the axis of the ROSA Arm Reference Frame with the patient's operative leg axis.
2. Align the end of the ROSA Arm Reference Frame (laser marked KNEE with an arrow) with the joint line of the operative knee.
3. Click NEXT to proceed to Robotic Unit immobilization.



6.5 ROSA Knee Positioning (cont.)

 To move the Robotic Unit, use the handle on the back of the unit. Never use the ROSA Base Reference Bar or the ROSA Base Reference Frame.

 The Robotic Unit should be at approximately 45° angle to the operating table on the surgeon's side, as described in section 3.2.3 OR Setup.

Lock the Robotic Unit

1. Lock the four wheels of the Robotic Unit by pressing down on the pedal on each wheel.
2. Activate the immobilization system by pressing down the main lever in the back of the Robotic Unit.
3. Click NEXT when the Robotic Unit is locked.



6.6 Camera Positioning

Move the Robotic Arm to Camera Target Position

1. Press and hold the Foot Pedal to move the Robotic Arm to the camera target position.

 Risk of collision: When the Robotic Unit is in Automatic mode, stay clear of the Robotic Arm and its path to the next position.

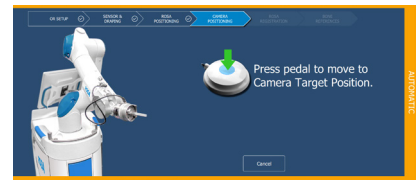

Position the Optical Unit

The Optical Unit should be on the opposite side of the surgeon and Robotic Unit, as shown in the user interface.

1. Follow the instructions on the screen to position the camera in the optimal position area and at the optimal height.
2. The camera is red when it is not in the optimal position. It turns green when the position is optimal.

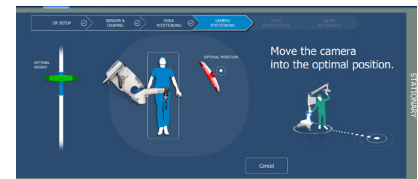

Adjust the Camera Angle

1. Angle the camera so that the laser is aiming at the center of the Navitracker installed on the ROSA Arm Reference Frame (Robotic Arm).
2. Click CONFIRM when the laser is centered on the Navitracker.

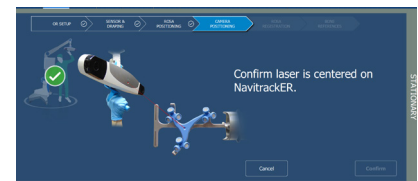

Lock the Optical Unit

1. Lock the four wheels of the Optical Unit by pressing down on the pedal on each wheel.
2. Click NEXT when the Optical Unit is locked.

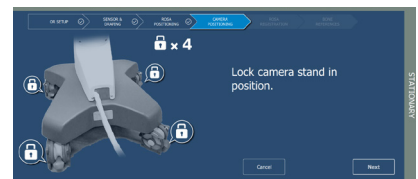

6.7 ROSA Knee Registration

1. Press and hold the Foot Pedal to perform the registration (six positions).



Risk of collision: When the Robotic Unit is in Automatic mode, stay clear of the Robotic Arm and its path to the next position.

Registration Failure

If there is a failure of the registration, a notification will appear on the user interface. Verify the following and re-do the registration:

- Is the ROSA Base Reference Frame firmly tightened?
- Is the ROSA Arm Reference Frame firmly tightened?
- Is the ROSA Arm Instrument Interface firmly tightened?
- Are the Navitracker devices fully seated on the instruments?
- Were any trackers not seen or only partially seen during registration?
- Is the Robotic Unit immobilized (main lock & four wheels)?
- Has the camera moved? Is it well-positioned?

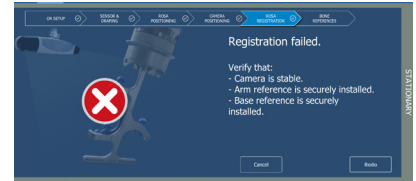
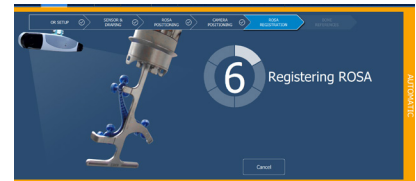

6.8 Bone References

The bone references are used to track the patient's femur and tibia and show the navigated instruments in relation to their respective positions.

Remove Instrument

1. Remove the ROSA Arm Reference Frame.

Perform Incision

Knee incision to expose the knee for the procedure should be performed prior to installing bone references. Incision and exposure of the knee joint should be performed based on the surgeon's choice of technique.

Depending on the type of incision used, bone references and pins can be placed inside the standard incision or outside the incision, through separate stab incisions.

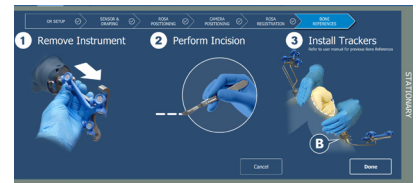

Install Trackers

1. Install trackers according to the procedures in section 6.8, 6.8.1, 6.8.2.1 and 6.8.2.2.
2. Click DONE when both trackers are installed to proceed to the FEMUR panel.



Verify the proper fixation of the patient references on the pins (femur and tibia). The femur and tibia references are secured on the pins, close to the patient's skin (without compression), using two hexagonal screws.





Bone references **MUST** be firmly attached to the bone and **MUST NOT** move at any moment during surgery. In case a bone reference has moved, the landmarks digitized on that bone must be acquired again.



Make sure that the pins are not positioned close to the bone cuts. Placing the pins close to the bone cuts location will increase the risk of breaking the pins with the cutting tools.

6.8 Bone References (cont.)

 Beware that muscle fibers may apply bending forces on the pins.

 Knee incision to expose the knee for the procedure should be performed prior to installing bone references.

6.8.1 Patient Femoral Reference

The femoral reference can be placed either inside or outside the incision.

 Be alert to the risk of causing damage to neurovascular structures including to the saphenous artery and vein, femoral artery and vein, or the popliteal artery and vein while installing the bone reference.

Femoral Reference placement outside the incision

1. Place the knee in flexion to install the femoral reference.
2. Use two fixed fluted pins (3.2x150 mm; refer to section 3.3.3) to install the patient femoral reference (2 Pins Reference Femur TS3).
3. Position the pins four fingers proximal to the knee incision to stay clear of the working area.
 - The pins can be inserted percutaneously through the vastus medialis in the femur
 - The pins should be set near-bicortically in the bone to ensure maximum stability
4. Position the reference close to the skin (without compression or soft tissue impingement) and tighten the two screws to secure to the pins.

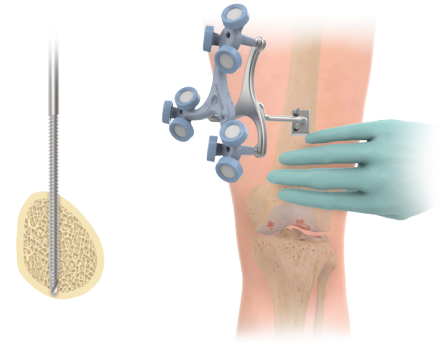

Bone Reference Installation

Femoral Reference Placement Inside the Incision

1. Position the pins two fingers proximal to the proximal edge of the trochlea.
2. Tilt the femoral reference towards the camera to avoid interference or contact between the femoral reference and the power tools, ROSA Cut Guide, implant or bone pins and screws.
 - The pins should be set bicortically in the bone to ensure maximum stability
3. Position the reference close to the bone/skin (without compression or soft tissue impingement) and tighten the two screws to secure to the pins.

 Use caution in osteoporotic bone.

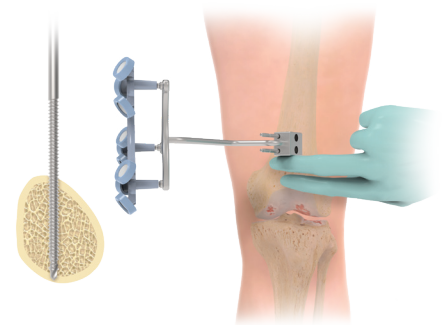

Bone Reference Installation

6.8.2 Patient Tibial Reference

6.8.2.1 ROSA Tibia Reference A/B

P/N: 20-8020-028-00/20-8020-029-00

The tibial reference can be placed either inside or outside the incision.

1. Use two fixed fluted pins (3.2 x 80 mm refer to section 3.3.3) to install the patient tibial reference (Tibia Reference A or B).

 Ensure that the pins are not placed in an area of interference with the tibial implant stem. Impact with the stem or broaching instruments can cause breakage of the pins and movement of the reference, which could result in inaccuracies.

 If a Persona IQ implant is used, please refer to the Persona IQ Surgical Technique (3640-US-en) in the Pre-operative Planning section.

 There is an A and B Tibial Reference Frame based on the OR setup.

Tibial Reference Placement Outside the Incision

1. Position the pins four fingers distal to the knee incision to stay clear of the working area.
 - The pins can be inserted percutaneously perpendicular to the medial surface of the tibial diaphysis.
 - The pins should be set near-bicortically in the bone to ensure maximum stability.
2. Position the reference close to the skin (without compression or soft tissue impingement) and tighten the two screws to secure to the pins.

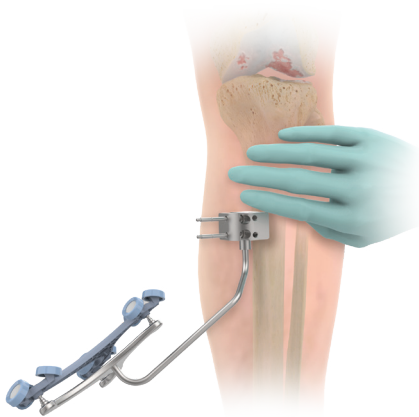

Bone Reference Installation





Near-Bicortical Pin Placement

Tibial Reference Placement Inside the Incision

1. Position the pins:
 - Three fingers distal to the joint line
 - On the anterior cortex, distal and medial to the articular surface and the anticipated position of the ROSA Cut Guide
 - The pins should be set bicortically in the bone to ensure maximum stability
2. Position the reference close to the bone/skin (without compression or soft tissue impingement) and tighten the two screws to secure to the pins.

6.8.2 Patient Tibial Reference (cont.)

 Remove the pins before final preparation to avoid breakage of the pins as well as movement of the reference.

 Use caution in osteoporotic bone.



Bone Reference Installation



Bicortical Pin Placement

6.8.2.2 Offset 2 Pins Reference Tibia

P/N: 20-8000-010-35/20-8000-010-36

 **Only for Placement Outside the Incision**

1. Use two fixed fluted pins (3.2 x 80 mm refer to section 3.3.3) to install the patient tibial reference.
2. (Offset 2 Pins Reference Tibia Size 6; Right or Left).
3. Position the pins four fingers distal to the knee incision, to stay clear of the working area.
 - Orient the NavitrackER approximately 10° toward the camera
 - The pins can be inserted percutaneously into the medial surface of the tibial diaphysis
 - The pins should be set near-bicortically in the bone to ensure maximum stability
4. Position the reference close to the skin (without compression) and tighten the two screws to secure to the pins.

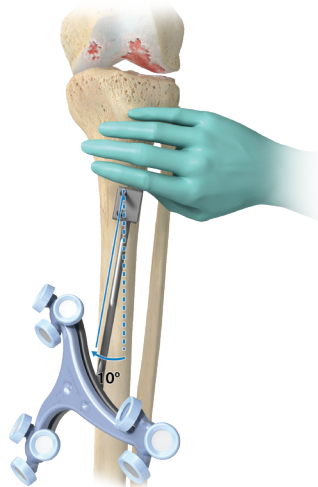

Bone Reference Installation



Near-Bicortical Pin Placement

 Ensure that the pins are not placed in an area of interference with the tibial implant stem. Impact with the stem or broaching instruments can cause breakage of the pins as well as movement of the reference, which could result in inaccuracies.

 There is a left and right Tibial Reference Frame based on the OR setup.

7. ROSA Knee Application- FEMUR Panel

Digitization of the bony landmarks is required to display the relevant information in the different panels. This system allows automatic registration of points using a stability criterion for the pointer. A movement of the instrument is first required to initiate the registration of the points. Confirmation sounds are played to advise the user that a point has been acquired successfully. The landmark to acquire will display with three colors:

White: Upcoming landmark point

Yellow: Current landmark point

Green: Successful landmark point

 Care must be taken not to pierce through the cartilage with the ROSA Registration Pointer's tip. Avoid damaged areas and osteophytes.

 The user should try to match landmarks as they are displayed on the bone model on the screen.

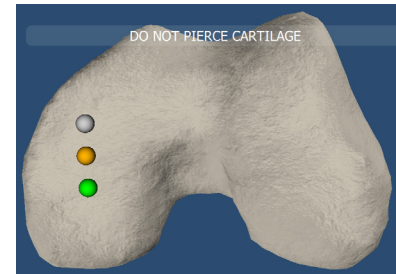

Requirements for Femoral Landmarks:

- A minimal displacement of 5 mm required between two consecutive points.
- A minimal distance of 20 mm must be observed between the following points:
 - Anterior and Posterior Trochlear Groove
 - Medial and Lateral Epicondyles
 - Medial and Lateral Distal Condyles

7.1 Femoral Head Center

Femoral head center detection is a crucial process that will influence the accuracy of bone resections.

1. Perform the detection of the femoral head center by recording 14 static positions of the leg.
 - For each acquired point, the leg should be stabilized until a confirmation sound is heard
 - The points should be taken in a large conical pattern with respect to the femoral reference
 - The minimal distance between each position is 20 mm



 The pelvis and Optical Camera must remain motionless during the whole femoral head digitization process to ensure finding the femoral head center.

 If a non-recommended pattern, such as two unique positions in flexion/extension or a small cone, is performed, the center of rotation algorithm will reject the result and a notification will appear asking the user to redo the acquisition.

 The contraindications for the femoral head center detection are hip pathologies severely limiting its range of motion (e.g. arthritis and hip dysplasia).

7.2 Femoral Axis Point



Together with the femoral head center, the Axis Point forms the femoral mechanical axis that is used as the main axis of the femoral coordinate system. The varus/valgus, flexion/extension and rotation values are computed relative to the mechanical axis.

1. Using the ROSA Registration Pointer, acquire the femoral Axis Point at the deepest point of the intercondylar notch.
 - It is recommended to determine the desired axis point on a pre-operative radiograph and compare it with the intra-operative location in situ



7.3 Femur Checkpoint (Optional)

The ROSA Checkpoint Screws on the femur should be installed proximal to the joint line and anterior to the medial epicondyle.

-  Avoid installing the ROSA Checkpoint Screws in regions of interference or contact with the power tools, ROSA Cut Guide, implant or bone pins.
-  Care must be taken not to over tighten the Checkpoint Screw during installation with power tools.





The Femur Checkpoint landmark is an optional landmark that can be used throughout the surgery to verify that the Femur Bone Reference has not moved since landmarking. The acquisition of this landmark will only be requested if the Bone Reference Checkpoint option was selected in the SURGEON Panel.

1. Using the ROSA Registration Pointer, acquire the position of the divot in the head of the Checkpoint Screw placed in the femur.

7.4 Posterior Condyles

The posterior condyles are used to determine the posterior condylar axis (PCA), which is used for the femoral rotational alignment.

1. Using the Universal Validation Tool Body with the appropriate size of ROSA Condyle Digitizer, acquire both posterior condyles at the same time.
 - Acquisition should be done between 0 and 6°, ideally at 3°
 - Knee should be flexed 90° before digitization of the points

-  Verify the proper assembly of the Universal Validation Tool Body and the ROSA Condyle Digitizer before the acquisition of the posterior condyles.
-  During acquisition, verify that the ROSA Condyle Digitizer is in contact with both posterior condyles. If proper contact is not achieved, implant sizing and posterior resection may be affected.

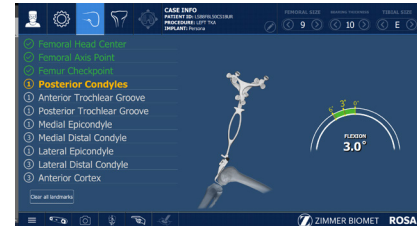

7.5 Anterior and Posterior Trochlear Groove

The anterior and posterior trochlear groove points are used to determine the A/P axis, which is used for the femoral rotational alignment.

1. Using the ROSA Registration Pointer, acquire the anterior and posterior trochlear groove points in the deepest portion of the trochlear groove.
 - There should be a minimal distance of 20 mm between the anterior and posterior trochlear groove points



7.6 Medial and Lateral Epicondyles

The medial and lateral epicondyles points are used to determine the epicondylar axis, which is used for the femoral rotational alignment. The M/L sizing of the femoral component is suggested based on these digitized points.

1. Using the ROSA Registration Pointer, acquire the medial and lateral epicondyles points on the medial and lateral epicondyles.
 - There should be a minimal distance of 20 mm between the medial and lateral epicondyle points





7.7 Medial and Lateral Distal Condyles

These points are used to compute the distal resection level.

1. Using the ROSA Registration Pointer, acquire the medial and lateral distal condyles using three points each at its most distal part.
 - There should be a minimal distance of 5 mm between consecutive points
 - There should be a minimal distance of 20 mm between medial and lateral condyles



To follow a Personalized Alignment technique, on the less affected condyle, the landmarks should be taken on the most distal part of the condyle with full cartilage thickness. The landmarks on the more affected condyle should be taken directly on the bone or region of most cartilage wear, avoiding regions of bony wear. When selecting the resection reference landmarks on the two condyles, the surgeon should estimate the thickness of cartilage wear on the more affected condyle.

-  Care must be taken not to pierce through the cartilage with the ROSA Registration Pointer's tip. Avoid damaged areas and osteophytes.
-  Final results depend on the accurate acquisition of landmarks. For accurate depth results, ensure that distal condyles are digitized most distally with respect to the distal cut, taking into account the flexion of the cut.

7.8 Anterior Cortex

These points digitized on the anterior cortex are used for the sizing of the femur and to assess potential for notching.

1. Using the ROSA Registration Pointer, acquire a first point on the anterior cortex along the desired medial-lateral location.
2. Acquire two more points on the anterior cortex inside the displayed bounding box.
 - The ROSA Registration Pointer's location is tracked in real time on the user interface using a round target with the number of remaining points to be acquired in the center (for image-based cases only)
 - The distance between each of the three points should be at least 5 mm
3. Once all femur landmarks have been acquired, the application will automatically transition to the TIBIA panel.

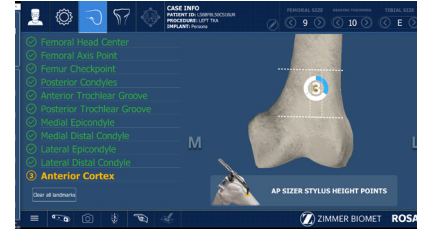

 Pick points where the AP Sizer stylus is normally positioned to assess sizing and notching.

7.9 FEMUR Panel-Error Notifications

Other error notifications are described in section 5.6. Application Visual notifications.

Femoral Head Center Error:

- The application could not determine the femoral head center. Please verify the following and perform the acquisition again:



- Pelvis did not move
- Femoral tracker is stable
- Camera is stable

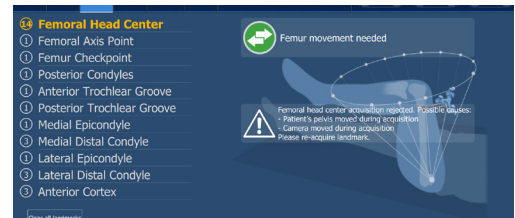

Bone Registration Not Successful

- The application could not register the 3D bone model with the landmarks acquired. Some landmarks may have been taken at the wrong location. Two options are possible:
1. Retake the landmarks displayed by the application, starting with the one in yellow.
 2. Switch to imageless (no 3D bone model). All landmarks will need to be re-acquired except the femoral head center.



 If a surgeon needs to switch to the imageless option, ensure the landmarks are taken at the correct locations. The landmarks will not be verified using the 3D bone model.

8. ROSA Knee Application- TIBIA Panel

Digitization of the bony landmarks is required to display the relevant information in the different panels. This system allows automatic registration of points using a stability criterion with the pointer. A movement of the instrument is first required to initiate the registration of the points. Confirmation sounds are played to advise the user that a point has been acquired successfully.

 Care must be taken not to pierce through the cartilage with the ROSA Registration Pointer's tip. Avoid damaged areas and osteophytes.

 The user should try to match landmarks as they are displayed on the bone model on the screen.

Requirements for Tibial Landmarks:

- A minimal distance of 20 mm must be observed between the following points:
 - PCL Insertion Point and Medial Third Tubercle
 - Medial and Lateral Plateau

8.1 Tibia Checkpoint (Optional)

The ROSA Checkpoint Screw on the tibia should be installed distal to the joint line and medial to the tibial tubercle.

 Avoid installing the ROSA Checkpoint Screw in regions of interference or contact with the power tools. ROSA Cut Guide, implant or bone pins.

 Care must be taken not to over tighten the checkpoint screw during installation with power tools.

 Remove the tibial bone screw before drilling and broaching to avoid breakage of the screws.

The Tibia Checkpoint landmark is an optional landmark that can be used throughout the surgery to verify that the Tibia Bone Reference has not moved since landmarking. The acquisition of this landmark will only be requested if the Bone Reference Checkpoint option was selected in the SURGEON Panel.

1. Using the ROSA Registration Pointer, acquire the position of the divot in the head of the Checkpoint Screw placed in the tibia.



8.2 Malleoli

In order to recreate the mechanical axis of the tibia, two points are digitized on the medial and lateral malleoli. The varus/valgus, flexion/extension and rotation values are computed relative to the mechanical axis.

1. Using the ROSA Registration Pointer, acquire the medial and lateral malleoli in the surgeon's preferred order.



8.3 Medial Third Tubercle

The neutral tibial rotation is defined by a point in the middle of the PCL insertion area on the tibia and one on the medial third of the tibial tuberosity. This axis should lie perpendicular to the posterior edges of the proximal tibia.



8.3 Medial Third Tubercle (cont.)

1. Using the ROSA Registration Pointer acquire a point on the medial third of the tibial tuberosity.
 - There should be a minimal distance of 20 mm between the PCL insertion point and medial third tubercle point

8.4 Tibial Axis Point

The tibial axis point is identified as the entrance point of the intramedullary canal. This point should be centered along the medial/lateral axis. A/P positioning should fall between the middle and one-third of the anterior edge of the tibial plateau.

1. Using the ROSA Registration Pointer, acquire the tibial axis point.

8.5 PCL Insertion Point

The neutral rotation is defined by a point in the middle of the PCL insertion area on the tibial plateau and one on the medial third of the tibial tuberosity. This axis should lie perpendicular to the posterior edges of the proximal tibia.

1. Using the ROSA Registration Pointer, acquire the PCL insertion area.
 - There should be a minimal distance of 20 mm between the PCL insertion point and medial third tubercle point

8.6 Medial and Lateral Plateau Resection References

The medial and lateral plateau resection references are used to compute the resection level, i.e. the planned tibial proximal resection will be below the acquired points.

1. Using the ROSA Registration Pointer, acquire the lowest point of the medial/lateral tibial plateau.
 - There should be a minimal distance of 20 mm between the medial and lateral plateau points

To follow a Personalized Alignment technique, on the less affected plateau, the landmarks should be taken on the lowest point of the plateau with full cartilage thickness. The landmarks on the more affected plateau should be taken directly on the bone or region of most cartilage wear, avoiding regions of bony wear. When selecting the resection reference landmarks on the two plateaus, the surgeon should estimate the thickness of cartilage wear on the more affected plateau.



Care must be taken not to pierce through the cartilage with the ROSA Registration Pointer's tip. Avoid damaged areas and osteophytes.

Once both the femoral and tibial landmarks have been acquired, the application will proceed to the EVALUATION Panel (if selected in SURGEON Panel) or otherwise to the PLANNING panel.

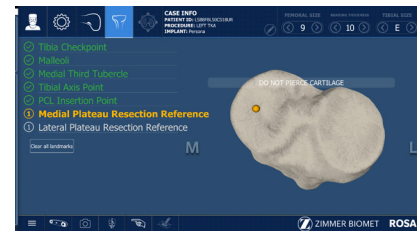
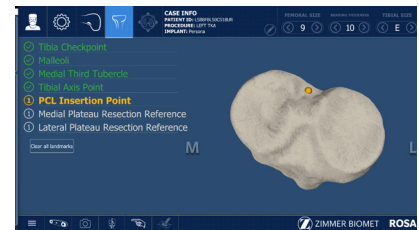
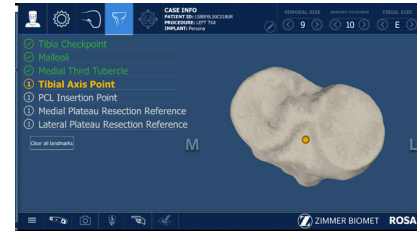

8.7 TIBIA Panel-Error Notifications

Other error notifications are described in section 5.6. Application Visual Notifications.

Bone Registration Not Successful

- The application could not register the 3D bone model with the landmarks acquired. Some landmarks may have been taken at the wrong location. Two options are possible:

1. Retake the landmarks displayed by the application (for example here: tibial canal entry and lateral plateau resection reference), starting with the one in yellow.
2. Switch to imageless (no 3D bone model). All landmarks will need to be re-acquired.

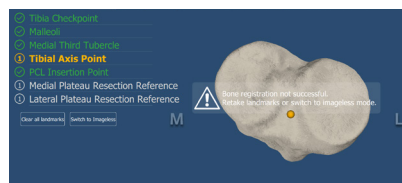

If a surgeon needs to switch to the imageless option, ensure the landmarks are taken at the correct locations. The landmarks will not be verified using the 3D bone model.

9. ROSA Knee Application- EVALUATION Panel (Optional)

After acquiring the femoral and tibial landmarks and if the option has been selected in the SURGEON panel, the user will have access to the EVALUATION panel. The surgeon can move the operative knee through a series of optically tracked movements of the leg, captured using the Foot Pedal, to evaluate the patient's knee. The ROSA Knee System will quantify, display and save various characteristics of the knee condition. This assessment can be performed at three distinct stages of the surgery each in a different tab: INITIAL, INTRA-OP (intra-operative) and FINAL.

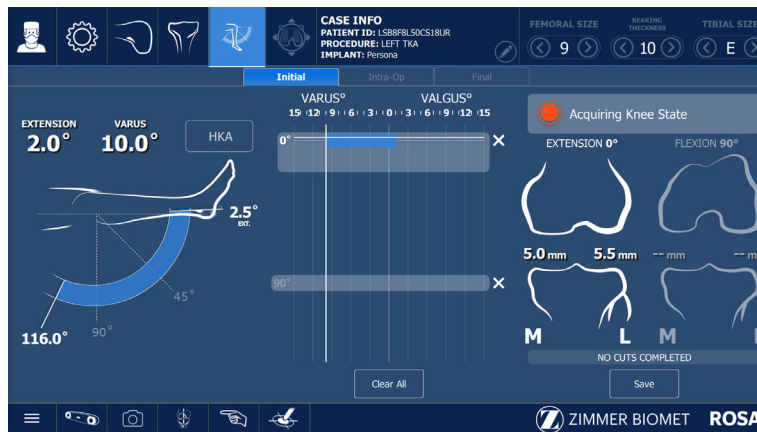

EVALUATION Panel

Range of Motion

- A movement of the leg is first required to initiate the procedure
- The surgeon can perform the range of motion test that will capture in blue the minimum and maximum flexion angles of the knee
- The HKA alignment of the leg is also displayed and can be recorded in its initial state (INITIAL tab) at any time during the procedure (Intra-Op tab) or when the resections are completed (FINAL tab) by clicking the HKA button

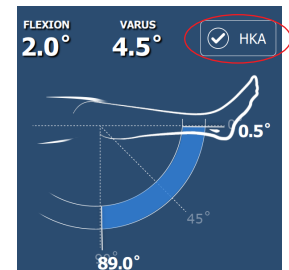

Laxity Test

1. Flex the knee to a pre-set angle, then press the Foot Pedal to record varus and valgus stress. The Foot Pedal icon turns into a red dot during the acquisition to indicate that values are being recorded. Repeat for other angles of flexion.
 - By default, knee laxity is measured in full extension (0° of flexion) and at 90° flexion. Other preference-based angles are available (SURGEON panel): 30°, 45°, 60° and 120°
 - The maximum varus/valgus angle values are recorded in the indicators for each angle (blue bar)
 - ROSA Knee System allows individual acquired values of the laxity test to reset by clicking the "X" symbol next to each angle or all values by clicking CLEAR ALL

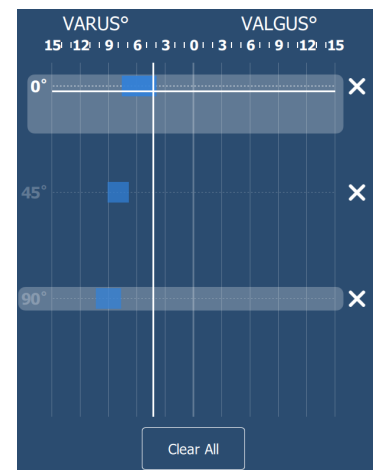

! Varus/valgus will only be recorded when the angle line is over the highlighted box and the Foot Pedal is pressed.

9. ROSA Knee Application-EVALUATION Panel (Optional) (cont.)

Space Display

- ROSA Knee System displays the maximum space in the medial and lateral compartments in millimeters with the knee in extension (between -5° to 20°) and in flexion ($90^{\circ} \pm 5^{\circ}$)
- At all times, the user has the option of clearing all values (CLEAR ALL) or saving the values (SAVE)

In all three tabs, the same knee assessments can be performed. The acquired values can be used to guide the surgeon in planning implant position (PLANNING panel) and can assist in clinical decisions on soft tissue management.

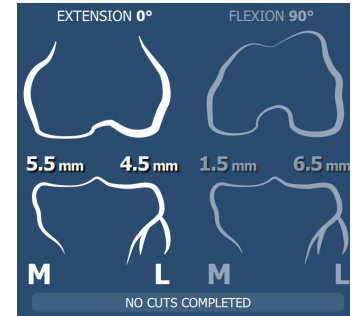

Initial Knee State

In the INITIAL tab, the knee must be in its initial condition, i.e. osteophytes may still be present or soft tissue including the ACL may be present regardless if it will be removed during the procedure. The INITIAL tab can be used to evaluate the initial HKA, the pre-operative flexion contracture and the varus/valgus range of motion.

- When clicking SAVE, the user will be asked if the knee was in a prepared state for surgery during the assessment before proceeding to the PLANNING panel
- After saving the knee state assessment in the INITIAL tab, any time the user returns to the EVALUATION panel prior to finishing all cuts, the system will show the INTRA-OP tab with the latest saved values

 The Balance Tool will not display the laxity values if the knee was not confirmed to be prepared for surgery.

Intra-Op Knee State

The INTRA-OP tab requires that the knee is in a representative state of when the implants will be in place, i.e., large osteophytes and the ACL and PCL (if applicable) have been removed. Since the intra-operative knee state evaluation can be done as many times as desired, the last saved values will be shown.

 If the knee was not prepared for the initial knee state evaluation, when clicking SAVE in the INTRA-OP tab, the user will be asked if the knee was in a prepared state for surgery during the assessment before proceeding to the PLANNING panel.

Final Knee State

The FINAL tab becomes available upon the completion of all resections (femur, tibia and 4-in-1). The FINAL tab requires that the trials or final implants are in place during the assessment.

 The final assessment with the trials or final implants should not be evaluated in the INITIAL or INTRA-OP tabs. The algorithm does not take the implant geometry into consideration.

10. ROSA Knee Application- PLANNING Panel

The PLANNING panel of the ROSA Knee application is used intra-operatively by the surgeon to set the femur and tibia bone resections and implant components. Based on the intra operatively planned values, the Robotic Arm will move to the appropriate positions to execute the surgical plan.

10.1 PLANNING Panel Overview

PLANNING Panel–Image-based Cases



PLANNING Panel– Imageless Cases

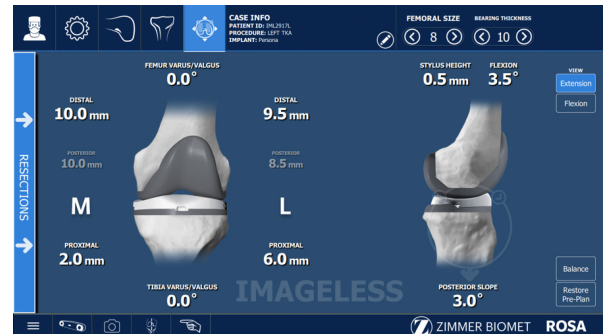

The PLANNING panel for image-based and imageless cases displays the same functions in the top and bottom task bars, except the type and size of the tibial component cannot be selected in the imageless cases (see below). The 3D bone model is shown for both image-based and imageless cases, however the model presented for imageless cases is not representative of the actual patient anatomy. The main panel for imageless cases has an “IMAGELESS” watermark and does not offer the axial view, nor the option buttons for showing the implants, cuts, axis (always shown in flexion) and landmarks.

 A watermark indicating the imaging modality (imageless, MRI, X-RAY) is displayed at all times in the PLANNING panel.

10.1.1 Implant Selection

Implant Editor

- The implant brand, type of femoral component, type of tibial component (only for image-based cases) and instrumentation can be selected by clicking EDIT in the middle of the top task bar under CASE INFO

Refer to Appendix A to see implants supported by the ROSA Knee System.

 The user cannot select incompatible brands.

 Verify regional availability of implants prior to selection in the Implant Editor (including sizing).

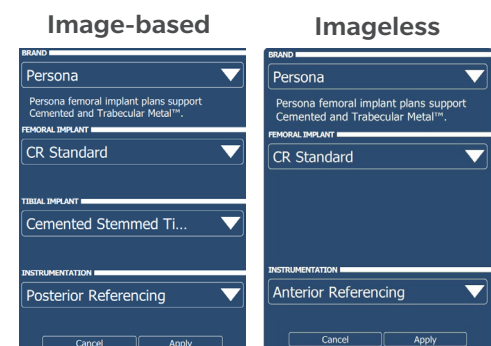

10.1.1 Implant Selection (cont.)

Implant Size Selectors

- The size of the femoral component, bearing thickness and the size of the tibial component (only for image-based cases) can be modified directly on the right side of the top task bar

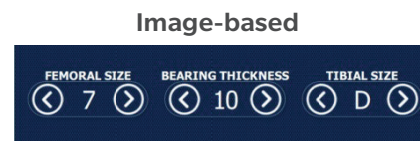

Imageless

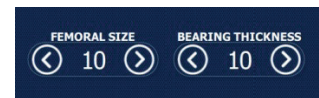

10.1.2 Implant Manipulator

Image-based Cases

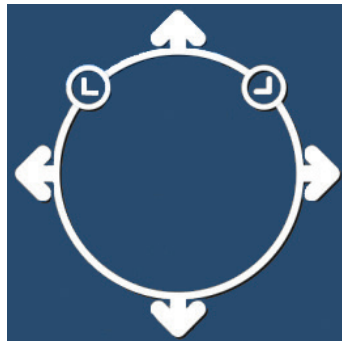

Imageless Cases

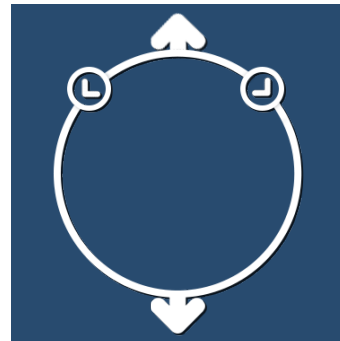

Touch the femoral or tibial component in any view: extension, flexion or axial (tibial component only), to display the implant manipulator:

- The large up/down arrows control resection
- The large side arrows control translation
- The small, encircled arrows control rotation

10.1.3 Frontal View

Image-based Cases

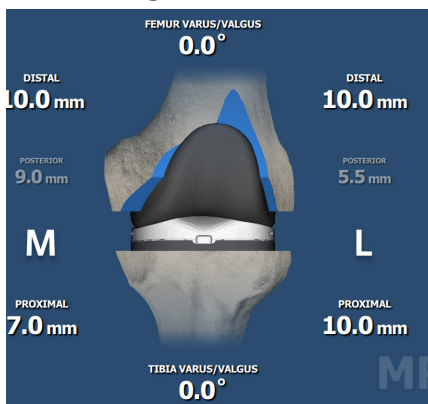

Imageless Cases

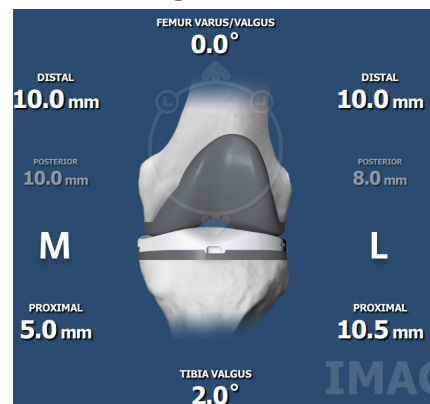

The frontal view of the PLANNING panel displays:

Femoral Bone

In flexion and extension:

- Varus/valgus angle
- Medial and lateral distal resections
- Medial and lateral posterior resections

10.1.3 Frontal View (cont.)

In flexion only:

- Implant rotation angle according to different axes (PCA by default; TEA and A/P according to preferences in SURGEON panel) (when FLEXION is selected in the VIEW options)
- Assessed PCA Rotation angle based on last femoral rotation assessment (when FLEXION is selected in the VIEW options)

Tibial Bone

- Medial and lateral proximal resections
- Varus/valgus angle

10.1.4 Lateral View

Image-based Cases



Imageless Cases

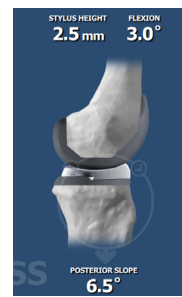

The lateral view of the PLANNING panel displays:

- Femoral Bone
 - Stylus height
 - Flexion angle
- Tibial Bone
 - Posterior slope angle

For image-based cases, it is possible to rotate the 3D bone model in the lateral view:

- House icon: 3D bone model returns to the original lateral view
- Rotation icon: Activates the rotation of the 3D bone model. Swipe the Touchscreen left or right to turn the 3D bone model

10.1.5 Tibia Axial View

Image-based cases

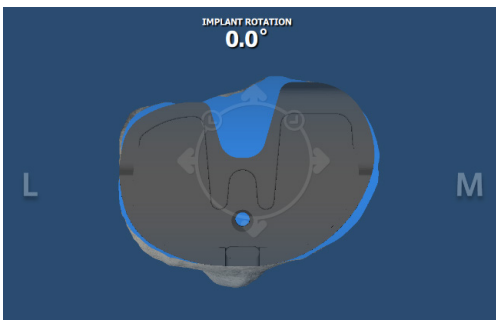

Imageless cases

No tibia axial view for imageless cases

The tibia axial view of the PLANNING panel displays:

- Tibial component
 - Implant rotation angle

10.2 Viewing Options

For image-based cases, the viewing options of the PLANNING panel are:

- EXTENSION/FLEXION/AXIAL TIBIA: Displays the knee in extension, flexion or axial view of the tibia
- IMPLANTS: Toggles the display of the implants on/off
- CUTS: Toggles display of the cuts and proximal tibial resection line on/off
- AXES: Toggles on/off the display of the axes (only in FLEXION view)
 - Implant rotation angle relative to the PCA axis (default axis)
 - Implant rotation angle relative to the TEA axis (preference-based)
 - Implant rotation angle relative to the AP axis (preference-based)
- LANDMARKS: Toggles on/off the display of the acquired landmarks
- BALANCE: Displays the Balance tool
- TRANSPARENCY: Toggles between a transparent and opaque visualization of the bone models
- RESTORE PRE-PLAN: Allows to revert to initial plan (by default: pre-operative planning)

For imageless cases, the viewing options of the PLANNING panel are:

- EXTENSION: Displays the knee in extension
- FLEXION: Displays the knee in flexion
- BALANCE: Displays the Balance tool
- RESTORE PRE-PLAN: Allows to revert to initial plan (by-default: surgeon's preferences)

Image-based Cases

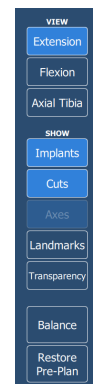

Imageless Cases



10.3 Balance Tool

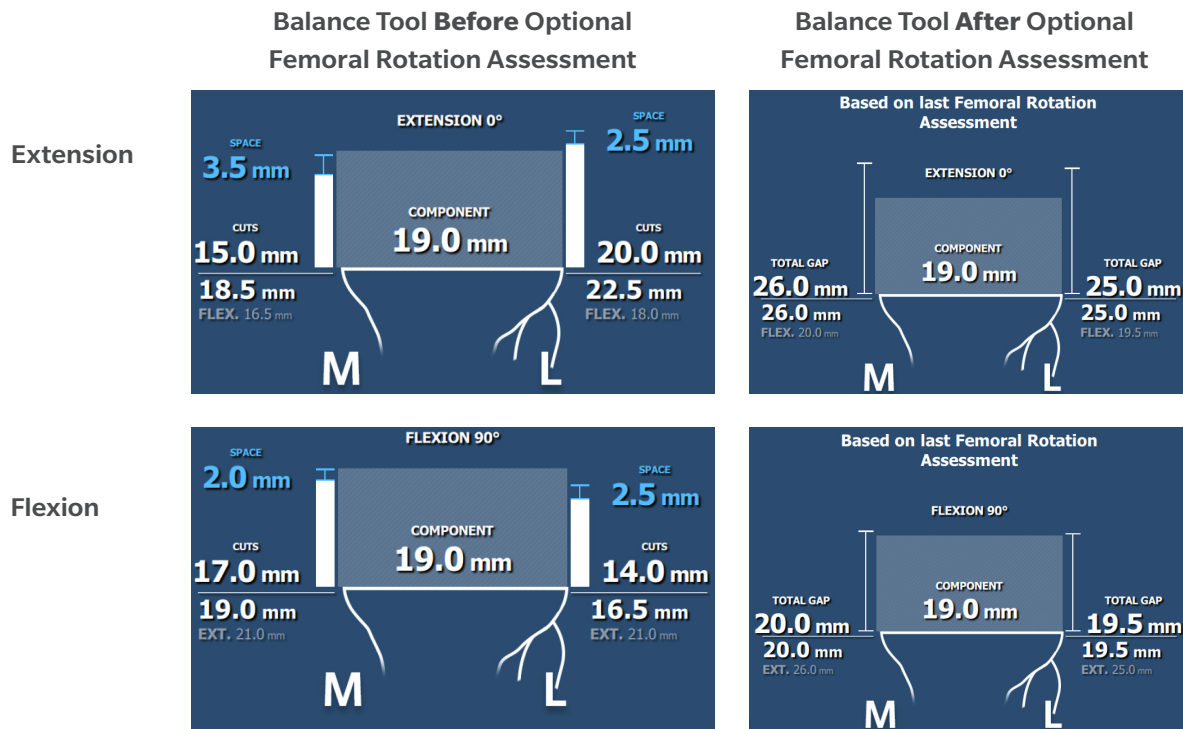

Before the Optional Femoral Rotation Assessment

The Balance tool before the optional femoral rotation assessment shows the same information in the EXTENSION and FLEXION views:

- Generic representation of the tibia with medial/lateral identifier
- Component thickness: Total thickness of the femoral and tibial components (with polyethylene)
- Medial and lateral cut values
- Medial and lateral space values
- Sum of the cuts and space on the medial and lateral sides, in flexion and in extension

The space values (laxity) are generated during the knee state evaluation (EVALUATION panel). Space values can only be modified by changes in the knee state evaluation. Cut values can be adjusted using bone resections, femoral rotation and implant sizing.

After the Optional Femoral Rotation Assessment

Once the femoral rotation assessment is complete, the medial and lateral gaps are no longer split into cuts and space values. Only "Total Gap" will be shown, which is the overall gap.

- Extension: The total gap is assessed with the spacer block in place
- Flexion: The total gap is assessed based on the femoral rotation assessment, which equals the distraction distance plus the planned posterior resection

10.4 Femoral and Tibial Components Planning

For image-based cases, the initial plan will be based on surgeon preferences and any modifications made in the pre-operative plan. For imageless cases, the initial plan is based on surgeon preferences.

1. In the implant editor, confirm the implant brand, the femoral and tibial components, as well as the instrumentation preference (anterior or posterior).
2. In the viewing options, set the VIEW of the knee to EXTENSION.
3. In the frontal view, set the varus/valgus angle of the femoral and tibial components.
4. In the lateral view, set the flexion angle of the femoral component.
5. In the lateral view, set the slope angle of the tibial component.
6. In the viewing options, set the VIEW of the knee to FLEXION.
7. In the frontal view, set the femoral rotation.
8. In the frontal view, set the femoral distal resection and tibial proximal resection.

Posterior Referencing Instrumentation

1. In the lateral view, set the posterior resection.
2. Select the implant size of the femoral component based on the stylus height and anterior resection.

Anterior Referencing Instrumentation

1. In the lateral view, set the anterior resection based on the stylus height.
2. Select the size of the femoral component based on the posterior bone resection.
3. In the frontal view, set the medio-lateral positioning of the femoral component.
4. In the viewing options, set the VIEW of the knee in AXIAL TIBIA.
5. Set the rotation of the tibial component.
6. Set the implant size of the tibial component.
7. Set the medio-lateral positioning of the tibial component.
8. Review the overall surgical plan.

Personalized Alignment Surgical Technique

Distal resection:

- On the less affected condyle, the distal resection should be set to be equal to the implant thickness
- On the more affected condyle, the distal resection should be set to the implant thickness minus the estimated cartilage wear by adjusting varus/valgus of the implant

 ROSA Knee limits the mechanical varus/valgus alignment to $\pm 5^\circ$ on the femur.

Posterior Resection:

- If there is full cartilage thickness present on the posterior condyles, posterior resection should be set equal to the thickness of the posterior aspect of the implant. The femoral rotation should be set to 0° from the posterior condyle axis
- If cartilage wear is present, the resection on the affected condyle should be set to the implant thickness minus the estimated cartilage wear by adjusting rotation of the implant

 ROSA Knee limits the rotation alignment from 3° internal to 10° external relative to the posterior condyle axis.

10.4 Femoral and Tibial Components Planning (cont.)

Tibial Proximal Resection:

- On the less affected plateau, the proximal resection should be set equal to the implant thickness.
- On the more affected plateau, the proximal resection should be set to the implant thickness minus the estimated cartilage wear by adjusting varus/valgus of the implant

 ROSA Knee limits the mechanical varus/valgus alignment to $\pm 5^\circ$ on the tibia.

After the Femoral Rotation Assessment

Once the femoral rotation assessment is performed (if the option is selected in the SURGEON panel), the surgical flow will come back to the PLANNING panel. If the femoral rotation value following the pull test was applied to the surgical plan, review the following steps:

1. In the viewing options, set the VIEW of the knee in FLEXION.
2. In the frontal view, review the femoral distal resection and tibial proximal resection.

Posterior Referencing Instrumentation

1. In the lateral view, review the posterior bone resection.
2. Review the implant size of the femoral component based on the stylus height and anterior bone resection.

Anterior Referencing Instrumentation

1. In the lateral view, review the anterior cut based on the stylus height.
2. Review the implant size of the femoral component based on the posterior bone resection.
3. In the frontal view, review the medio-lateral positioning of the femoral component.
4. Review the overall surgical plan.

 Parameters in the PLANNING panel influence each other. Make sure to review the overall surgical plan before proceeding to the RESECTIONS drawer.

 If a Persona IQ implant is used, please refer to the Persona IQ Surgical Technique (3640-US-en) in the Pre-operative Planning and Sizing and Drilling of Tibia sections.

 The Balance tool can be used at all times to help perform the surgical plan.

10.5 PLANNING Panel-Error Notifications

Notching

A notification will appear next to the stylus height in the lateral view when its value is equal to or less than 0 mm.

- The posterior resection and the size of the femoral component will affect notching

Implant Incompatibility

A notification will appear under the implant selector and the RESECTIONS drawer will become inaccessible (Refer to Appendices B and C for implant compatibility).

- The size of the femoral and tibial components will affect implant compatibility

Planning Values Out of Range

A notification will appear in the bottom task bar (“Planning value out of range”), the affected bone resection value will be displayed in orange, and the RESECTIONS drawer will become inaccessible.

- Bone resection and varus/valgus can be adjusted to decrease an excessive bone resection



10.6 PLANNING Limits

The planning of the ROSA Knee application has the following limit values in terms of varus/valgus, femur flexion, tibial slope, distal and proximal resection and femoral rotation:

Panel Component	Femur	Tibia
Varus/Valgus	5.0° varus to 5.0° valgus	5.0° varus to 5.0° valgus
Flexion	3.0° extension to 8.0° flexion	N/A
Slope	N/A	5.0° anterior to 12.0° posterior
Resection	1.0 mm to 18.0 mm distal from the most prominent distal condyle	2.0 mm to 14.0 mm proximal from the highest tibial plateau
Axial rotation	3.0° internal to +10.0° external rotation relative to the PCA	20.0° internal rotation to 15.0° external rotation

 Refer to specific implant system Surgical Technique for recommended implant positioning.

11. ROSA Knee Application- RESECTIONS Drawer

The RESECTIONS drawer of the ROSA Knee application is used intra-operatively for the surgeon to perform the femoral distal resection, tibial proximal resection, the femoral rotation assessment (optional) and the femoral 4-in-1 positioning according to the chosen implant components. Based on the intra-operative planned values, the Robotic Arm will move to the appropriate positions to execute the surgical plan. The RESECTIONS drawer is accessible from the PLANNING panel on the left of the screen.

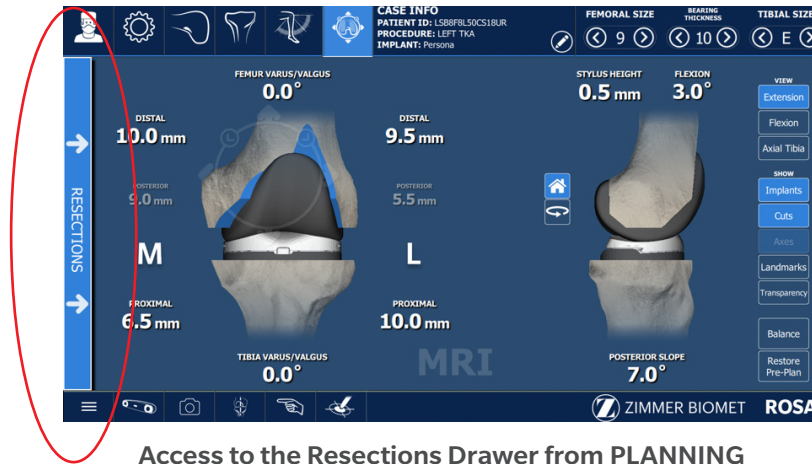





11.1 RESECTIONS Drawer Overview

The RESECTIONS drawer is the same for both image-based and imageless cases. It consists of:

- CUT GUIDE CHECKPOINT: Allows the verification of the registration and that the correct Cut Guide is installed before performing resections
- BONE CHECKPOINT (optional): Allows for verification of the Bone Reference stability
- FEMORAL DISTAL RESECTION: Surgical flow to perform the femoral distal resection
- TIBIAL PROXIMAL RESECTION: Surgical flow to perform the tibial proximal resection
- FEMORAL ROTATION (optional): Flow to perform the femoral rotation assessment
- FEMORAL 4-IN-1 RESECTION: Surgical flow to perform the femoral 4-in-1 positioning

11.1 RESECTIONS Drawer Overview (cont.)

The user can choose to start with either the femoral or tibial resection. While in the RESECTIONS drawer, direct access to other panels is disabled. To access the panel buttons, close the RESECTIONS drawer using the tab to the right of the screen.

-  A knee positioner, such as the De Mayo Knee Positioner, is recommended to be used with the ROSA Knee System, otherwise accuracy may be impacted.
-  The function ROSA Home is not accessible when in a resection flow. To access this function, cancel the flow and access the feature in the surgery drawer or any other panels.
-  The Cut Guide Checkpoint is performed upon entry in the RESECTIONS drawer. The checkpoint also can be performed at any time when the RESECTIONS drawer is accessible, to verify registration (ROSA Base Reference Frame did not move) or to confirm the correct Cut Guide is used.
-  The FEMORAL 4-in-1 RESECTION becomes accessible when the distal resection has been performed. FEMORAL ROTATION (optional) becomes accessible when the femoral and tibial resections have been performed.
-  The SHOW PLAN button displays the values from the surgical plan for the following steps: Pinning of the Cut Guide, sawing and validation.

There are two additional buttons available in the RESECTIONS drawer:

COLLABORATIVE MODE

- Puts the Robotic Arm in Collaborative mode where the user can manually move it by applying a gentle force to the end of the Robotic Arm

VALIDATION

Allows for validation of the cuts.

- Select a bone to validate resection

Femoral Distal Resection



1. Position the flat surface at the end of the Universal Validation Tool Body on the resected distal femoral surface (without the Condyle Digitizer attached).

Tibial Proximal Resection

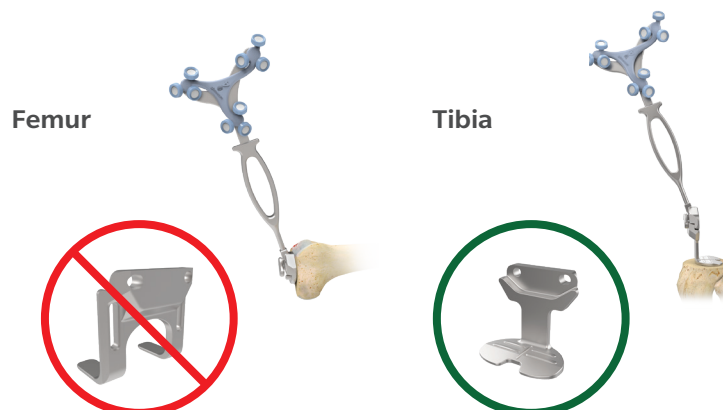
1. Assemble the Universal Validation Tool Body with the ROSA Knee Tibia Validation Tool (or Distal & Posterior Condyles Digitizer).
2. Position the flat bottom surface of the ROSA Knee Tibia Validation Tool or the feet of the Distal & Posterior Condyles Digitizer on the resected proximal tibial surface.



11.1 RESECTIONS Drawer Overview (cont.)

-  For the validation of the tibial proximal resection, make sure the Universal Validation Tool Body and the ROSA Knee Tibia Validation Tool (or Distal & Posterior Condyle Digitizer) are locked together using the lever.
-  Make sure the bone resection surface is flat and free of bone fragments before validation.

11.2 ROSA TKA Cut Guide Installation and Checkpoints

Cut Guide Installation

1. Upon entry in the RESECTIONS drawer, install the required ROSA TKA Cut Guide (implant family; A or B) to the ROSA Arm Instrument Interface by firmly tightening the two captive screws by hand.
2. Click NEXT to proceed to the checkpoint.

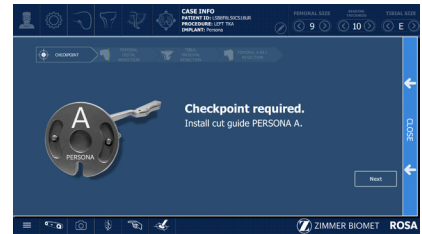

Cut Guide Checkpoint

1. Once the ROSA TKA Cut Guide is installed, place the tip of the ROSA Registration Pointer in the checkpoint (divot near the base of the Cut Guide).
2. If the checkpoint is unsuccessful, please verify the following and redo the checkpoint:
 - Is the correct ROSA TKA Cut Guide installed?
 - Is the ROSA TKA Cut Guide firmly tightened?
 - Has the ROSA Base Reference Frame moved? (If it has moved, registration of the robot needs to be redone.)



Bone Reference Checkpoint

If the Bone Reference Checkpoint option was selected in the SURGEON Panel, the BONE REFERENCE VERIFICATION panel will be displayed after the Cut Guide Checkpoint is completed.

1. Place the tip of the ROSA Registration Pointer in the Checkpoint Screw divots placed on the femur and the tibia.
 - If the Bone Reference checkpoint is unsuccessful, please verify the following and redo the checkpoint:
 - Is the Bone Screw securely installed?
 - Is the Bone Reference secure?
 - Are the NavitrackERS secure on the Bone Reference and Registration Pointer?

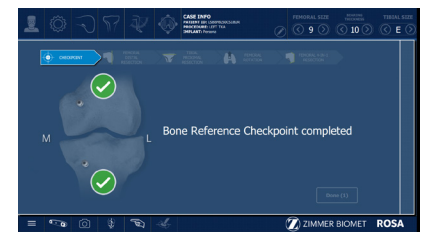

(If movement was detected and the cuts are not performed, landmarking should be redone. The user may also dismiss the step, if desired.)

11.3 Femoral Distal Resection

Select Resection to Perform

1. Select the tab for FEMORAL DISTAL RESECTION.

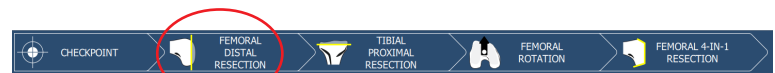

Automatic Mode: Robotic Arm to Cut Plane

2. Press and hold the Foot Pedal to automatically move the Robotic Arm to the femoral cut plane. Hold the pedal until the Robotic Arm switches to Collaborative mode.

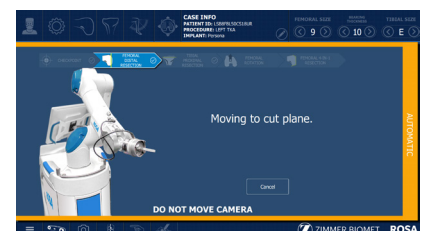

11.3 Femoral Distal Resection (cont.)

-  Risk of collision: When the Robotic Unit is in Automatic mode, stay clear of the Robotic Arm and its path to the next position.

Collaborative Mode: Robotic Arm to Cut Plane

- Once in Collaborative mode, press and hold the Foot Pedal and apply a gentle force on the ROSA TKA Cut Guide to move the Cut Guide to the bone for pinning.



-  The Robotic Arm at this point is in Planar mode, i.e. its movements are restricted to the femoral cut plane only.

-  Trackers must be visible at all times during bone tracking.

First Pin Installation and Live Cut Values

- Keep the Foot Pedal pressed and install the first pin in the Cut Guide.
 - Make sure to use the holes labeled FEMUR for pinning.
- When the first pin is installed, confirm that the live cut values are acceptable by clicking YES.



-  Continue pressing the Foot Pedal while pinning or drilling in Collaborative mode to enable Bone Tracking mode, otherwise accuracy may be impacted. Visual and audio notifications are provided if the Foot Pedal is released in Collaborative mode.

-  The user must acknowledge Cut Guide placement by reviewing live cut values and deciding whether they are acceptable by clicking the YES button.

-  Before performing the resection, it is recommended to verify the cut plane with standard instrumentation, such as the alignment rod and the resection guide (angel wing).

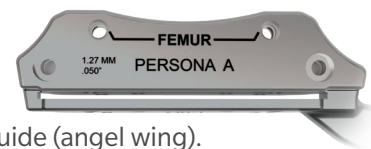

Pinning and Bone Resection

- Once the first pin installation and live cut values are confirmed, the robot is in Stationary mode and the Foot Pedal can be released. Insert the second pin and an oblique pin (if additional stability is needed).
 - It is recommended to use two pins to stabilize the Cut Guide: two FEMUR pin holes with option to use oblique pin holes
- Perform the femoral distal resection.
 - The resection can be validated before removing the pins
- Click the CUT VALIDATION button and position the Validation tool on the distal cut. The user interface should show all green checkmarks.
- Once the resection is completed, remove all pins and click the PINS REMOVED button.



-  Before disengaging the Cut Guide, make sure that all pins are removed.

-  For highest precision, use Zimmer Biomet saw blades (25090127AGC, 25090137AGC).

Disengaging the Cut Guide

- Press and hold the Foot Pedal and disengage the Cut Guide by applying a gentle force to pull away the Cut Guide until the desired position is reached. Then click CLOSE.
 - If the cut was not previously validated, the system will prompt the user to validate the cut

11.3 Femoral Distal Resection (cont.)

-  If the validated flexion values are triggering a potential notching, a notification will be displayed. The user should consider recutting and/or verifying the potential for notching with the angel wing prior to anterior resection.



11.4 Tibial Proximal Resection

Select Resection to Perform

1. Select the tab for TIBIAL PROXIMAL RESECTION.



Automatic Mode: Robotic Arm to Cut Plane

1. Press and hold the Foot Pedal to automatically move the Robotic Arm to the tibial cut plane. Hold until the Robotic Arm switches to Collaborative mode.

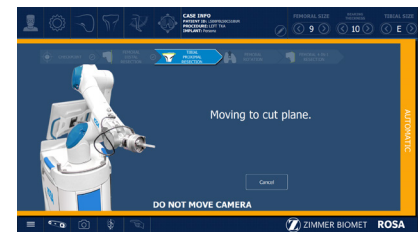

-  Risk of collision: When the Robotic Unit is in Automatic mode, stay clear of the Robotic Arm and its path to the next position.

Collaborative Mode: Robotic Arm to Cut Plane

1. Once in Collaborative mode, press and hold the Foot Pedal and apply a gentle force on the ROSA TKA Cut Guide to move the Cut Guide to the bone for pinning.





-  The Robotic Arm at this point is in Planar mode, i.e. its movements are restricted to the tibial cut plane only.

First Pin Installation and Live Cut Values

1. Keep the Foot Pedal pressed and install a first pin in the Cut Guide.
 - Make sure to use the holes labeled TIBIA for pinning.
2. When the first pin is installed, confirm that the live cut values are acceptable by clicking YES.



-  Continue pressing the Foot Pedal when pinning or drilling in Collaborative mode to enable Bone Tracking mode, otherwise accuracy may be impacted. Visual and audio notifications are provided if the Foot Pedal is released in Collaborative mode.

-  The user must acknowledge Cut Guide placement by reviewing live cut values and deciding whether they are acceptable by clicking on the YES button.

-  Before performing the resection, it is recommended to verify the cut plane with standard instrumentation, such as the alignment rod and the resection guide (angel wing).



Pinning and Bone Resection

1. Once the first pin installation and live cut values are confirmed, the robot is in Stationary mode and the Foot Pedal can be released. Insert the second pin and an oblique pin (if additional stability is needed).
 - It is recommended to use two pins to stabilize the Cut Guide: two TIBIA pin holes with option to use oblique pin holes
2. Perform the tibial proximal resection.



11.4 Tibial Proximal Resection (cont.)

3. The resection can be validated before removing the pins. Click on the CUT VALIDATION button and position the validation tool on the proximal cut. The user interface should show all green checkmarks.
4. Once the resection is completed, remove all pins then confirm by clicking PINS REMOVED button.

 For the validation of the tibial proximal resection, make sure the Universal Validation Tool Body and ROSA Knee Tibia Validation Tool (or Distal & Posterior Condyle Digitizer) are locked together using the lever.

 Before disengaging the Cut Guide, make sure that all pins are removed.

 For highest precision, use Zimmer Biomet saw blades (25090127AGC,25090137AGC).

Disengaging the Cut Guide

1. Press and hold the Foot Pedal and disengage the Cut Guide by applying a gentle force to pull away the Cut Guide until the desired position is reached.
2. If the cut was not previously validated, the system will ask to validate the cut.

11.5 Femoral Rotation (Optional)

This option will be accessible only if the Femoral Rotation tool was included by selecting “Apply to Workflow” in the SURGEON panel.

Tibial Proximal Resection Validation

1. Validate the tibial proximal resection as described in section 11.4.
 - Acquisition will be recorded and a transition to the validation of the femoral distal resection will be done automatically
2. To revalidate, click VALIDATE TIBIA.

For the validation of the tibial proximal resection, make sure the  Universal Validation Tool Body and ROSA Knee Tibia Validation Tool (or Distal & Posterior Condyle Digitizer) are locked together using the lever.

Femoral Distal Resection Validation

1. Validate the femoral distal resection as described in section 11.3.
2. Acquisition will be recorded and transition to the display of validation values will be done automatically.

Display of Validation Values

Once both resections have been validated, all values will be displayed.

1. Click NEXT to evaluate the extension gap.
2. Click VALIDATE FEMUR to redo the femoral validation, if necessary.
3. Click CANCEL to return to the RESECTIONS drawer main panel.

Leg Positioning

1. Move the leg to extension (-5° to 20° flexion).
 - Transition to the extension gap assessment will be done automatically



11.5 Femoral Rotation (Optional) (cont.)

Extension Gap Assessment

1. Insert a spacer block in the joint.
2. Assess the extension gaps by stressing the knee in varus and valgus, while keeping the leg in extension (-5° to 20°).
3. Modify the BEARING THICKNESS in the software to adjust the plan
4. Click the X symbol to clear the acquired values.
5. Click NEXT to proceed to the Femoral Rotation Assessment.
6. Click BACK to return to VALIDATION or CANCEL to return to the RESECTIONS drawer main panel.



Femoral Rotation Assessment

1. Put the leg in flexion ($95^{\circ} \pm 5^{\circ}$).
2. Perform a pull test (manually or with instruments, such as a laminar spreader or Zimmer FuZion) to assess the femoral rotation needed to balance the flexion gaps.
3. Click CAPTURE to record the femoral rotation value.



Apply Femoral Rotation to Planning

Once the femoral rotation has been captured, the value will be displayed according to TEA and PCA axes.

- Three options are then available:
 - APPLY: Apply the rotation to the surgical plan
 - REDO: Redo the pull test
 - DO NOT APPLY: Returns to PLANNING without applying the rotation to the surgical plan

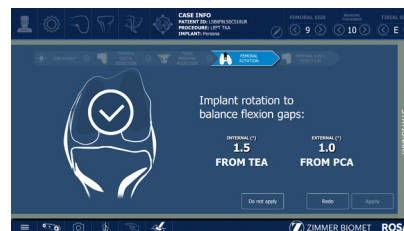

Return to Planning: Balance Tool

If the femoral rotation is applied to the surgical plan, the application will go back to the PLANNING panel. The assessed rotation values will be displayed and reflected in the Balance Tool.

1. Review the planning steps related to femoral rotation (section 10.4).



11.6 Femoral 4-in-1 Resection

Select Resection to Perform

1. Select the tab for FEMORAL 4-IN-1 RESECTION.

Automatic Mode: Robotic Arm to Femur

1. Press and hold the Foot Pedal to automatically move the Robotic Arm to the femur until the Robotic Arm switches to Collaborative mode.



Risk of collision: When the Robotic Unit is in Automatic mode, stay clear of the Robotic Arm and its path to the next position.

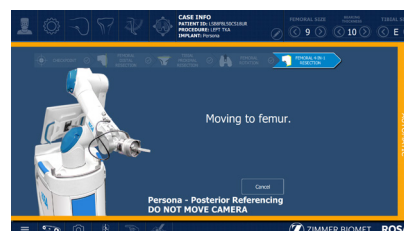

Collaborative Mode: Robotic Arm to Femur

1. Once in Collaborative mode, press and hold the Foot Pedal and apply a gentle force on the ROSA Cut Guide to move the Cut Guide to the bone for drilling the 4-in-1 holes.



The Robotic Arm at this point is in Planar mode, i.e. its movements are restricted to the femoral 4-in-1 plane only.

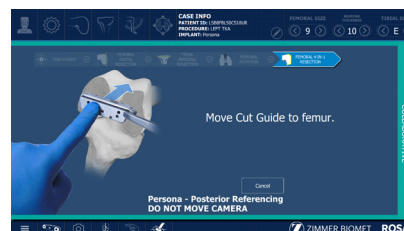

11.6 Femoral 4-in-1 Resection (cont.)

First Pin Installation and Live Cut Values

1. Verify the appropriate instrumentation (implant brand and reference; e.g. Persona – Posterior Referencing).
2. Verify that the mediolateral (ML) position of the Cut Guide is correct.
3. Keep the Foot Pedal pressed and install a first pin in the Cut Guide on the medial side.
 - Make sure to use the holes labeled 4-IN-1 for the 1st pin (medial).
4. When the first pin is installed, confirm that the live cut values are acceptable by clicking YES.



 Continue pressing the Foot Pedal when pinning or drilling in Collaborative mode to enable Bone Tracking mode, otherwise accuracy may be impacted. Visual and audio notifications are provided if the Foot Pedal is released in Collaborative mode.

 The user interface indicates the correct 4-in-1 Cut Guide to use by displaying the brand and referencing (e.g. Persona–Posterior Referencing).

 The user must acknowledge Cut Guide placement by looking at live cut values and deciding whether they are acceptable by clicking the YES button.

Drilling of 4-in-1 Holes

Once the ML position, live cut values, and first pin installation have been confirmed, the robot is in Stationary mode and the Foot Pedal can be released.

1. Drill the lateral 4-in-1 hole.
2. Remove all pins then confirm by clicking PINS REMOVED button.
 - Make sure to use the holes labeled 4-IN-1.



 Before performing the resection, it is recommended to verify the cut planes, especially the anterior and posterior cuts, with standard instrumentation, such as the resection guide (angel wing).

 Before disengaging the Cut Guide, make sure that all pins are removed.

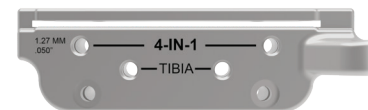

Disengaging the Cut Guide

1. Press and hold the Foot Pedal and disengage the Cut Guide by applying a gentle force to pull away the Cut Guide until the Robotic Arm reaches the desired position.
2. When desired position is reached, click CLOSE.

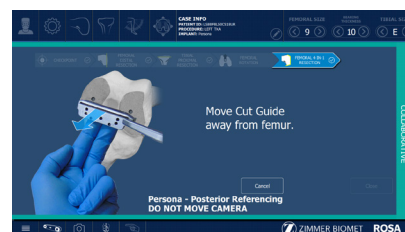

4-in-1 Bone Resections

 Before performing the 4-in-1 bone resections, make sure there is no notching using standard instrumentation, such as the resection guide (angel wing).

 For highest precision, use Zimmer Biomet saw blades (25090127AGC,25090137AGC).

Persona Implants, Vanguard Implants and NexGen Implants with PRI Instruments

1. Place the appropriate 4-in-1 Cut Guide on the distal femur by aligning the two pegs on the back of the 4-in-1 Cut Guide with the 4-in-1 holes in the distal femur.
2. Secure the appropriate 4-in-1 finishing guide using two 3.2 mm hex-head screws or trocar pins in the oblique holes and perform bone resections according to the standard surgical technique.
3. Remove the bone screws and pins, and then the 4-in-1 Cut Guide.

11.6 Femoral 4-in-1 Resection (cont.)

NexGen Implants with Legacy Instruments

1. Insert headless pins in the two 4-in-1 holes of the distal femur.
2. Place the NexGen 4-in-1 finishing guide onto the distal femur, over the headless pins.
3. Position the finishing guide mediolaterally by sliding it on the headless pins.
4. Secure the NexGen 4-in-1 finishing guide using two 3.2 mm hex-head screws or trocar pins in the oblique holes and perform bone resections according to the standard surgical technique.
5. Remove the bone screws and pins, and subsequently the 4-in-1 cut guide.

11.7 Checkpoint Screw Removal

If the Bone Reference Checkpoint feature was selected, a “Remove Checkpoint Screws” notification will be displayed after the 4-in-1 resection is completed.

1. Remove the Checkpoint Screws from the femur and tibia.
2. Click CONFIRM to confirm the Checkpoint Screw removal and proceed with Final Knee State Evaluation (if applicable) or Certify Data.

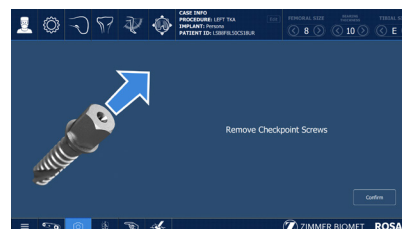

11.8 RESECTIONS Drawer–Error Notifications

Camera Movement During Resections (Femur, Tibia, 4-in-1)

If the camera is moved outside a certain volume, a notification will be displayed.

1. Reposition the camera within the registration volume and click NEXT to continue.
2. Click CANCEL and go to SETUP to redo the registration step (section 6.7).

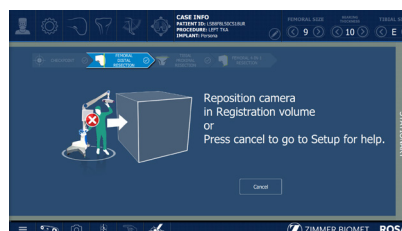

Knee Movement in Stationary Mode (Femur, Tibia, 4-in-1)

If at least one live cut value is outside 2° or 2 mm, a notification of “Knee movement detected” will be displayed.

1. Try to reposition the knee so that all checkmarks turn green.
2. If the issue cannot be resolved, click CANCEL, remove all pins then restart the cut flow.



Ensure ROSA Knee is Not Pinned to the Patient

When the surgical flow is cancelled during any bone resections, the user interface will display a notification to ensure the Robotic Unit is not pinned to the patient.

1. Remove pins connecting ROSA TKA Cut Guide to the patient.
2. Click CONFIRM once the Cut Guide is unpinned.



11.9 Final Knee State Evaluation (Optional)

With trial implants in place (or final implants), it is possible to perform a final knee state evaluation. Please refer to section 9 ROSA Knee Application–EVALUATION Panel.

11.10 Confirm Data

Following completion of the 4-in-1 Resection workflow and the Final Knee State Evaluation (if applicable), the surgeon will be prompted to confirm the final case data.

1. Review and save the final implant selection:
 - Brand
 - Component type and size
 - Bearing thickness
 - If necessary, changes can be made in the implant selector in the top task bar.
2. Review the Final HKA and Knee State Evaluation.
3. Select the appropriate option and then confirm:
 - Save data with trial components
 - Save data with final Implants
 - Not to save the data displayed

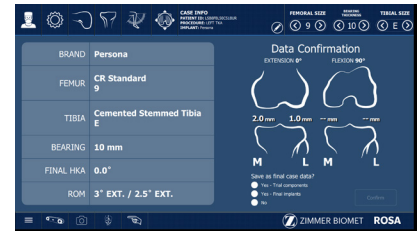

12. Robotic Errors

Collision Detection

If a collision is detected in Automatic mode, the Robotic Arm will automatically stop, switch to Stationary mode and a notification will appear on the user interface.

MANUAL DISENGAGE: If the ROSA TKA Cut Guide is pinned to the patient or if there is an obstacle in the way.

1. Remove pins (if applicable).
2. Confirm that the Robotic Unit is not pinned to the patient.
3. Return to the RESECTIONS drawer main panel.
4. Choose the Collaborative mode feature to manually disengage the Robotic Arm.

CONTINUE: If there are no more obstacles, restart to Automatic mode.

ROSA Knee is Realigning

This notification will appear when the leg was moved too fast and the Robotic Arm could not follow in Tracking mode. At this point, the robot is locked in Planar mode, aligned with the bone resection plane.

1. Keep the Foot Pedal pressed, wait for the Robotic Arm to readjust (Automatic mode) and reach the bone resection plane again, then the notification will disappear.
2. Or click CANCEL to exit the cut flow.

Cannot Reach Position

This notification will appear if the Robotic Arm can no longer reach the femur or the tibia. Verify that:

- Leg is in flexion and not in abduction or adduction
- ROSA Base Reference Frame is stable (checkpoint passes)
- Bone references have not moved since landmark selection

If the knee was repositioned, click **RETRY** to resume the surgical workflow or click **CANCEL** to exit the cut flow.

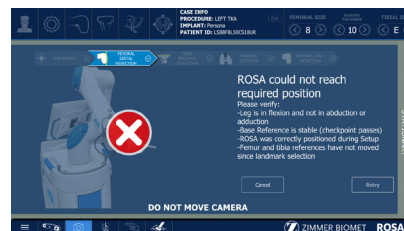
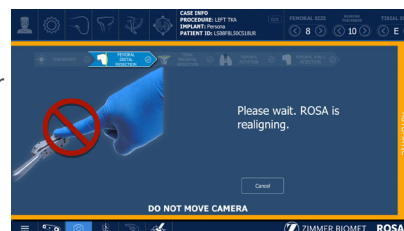
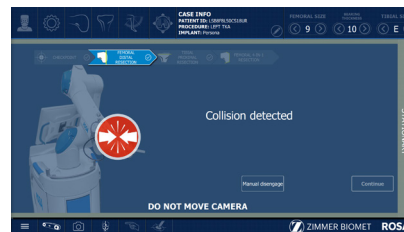

12. Robotic Errors (cont.)

Drifting of the Robotic Arm

Although the system cannot detect drifting (no notification), it is very easy to recognize. With the Foot Pedal pressed in Collaborative mode, the Robotic Arm will move without applying any force on it. Please verify:

- **Draping:** make sure the draping is not pulling on the end of the Robotic Arm where the Force Sensor is located
- **Force Sensor:** The Force Sensor was calibrated with a tool on the Robotic Arm. Go back in the SETUP panel to re-calibrate the Force Sensor

Red EMERGENCY Button

To stop the Robotic Arm at any time, press down the EMERGENCY button. An “Unknown Robotic Error” will be triggered. The EMERGENCY button is located on the Robotic Unit near the base of the Robotic Arm.

1. Press down to activate.
2. Turn clockwise to release.
3. Upon the release of the EMERGENCY button, follow the Force Sensor auto-recalibration (see below).



Excessive Force on the Robotic Arm

In case of an excessive force on the Robotic Arm, a notification will appear on the user interface:

- EXCESSIVE FORCE ON ROSA (shown in bottom task bar), the force applied is more than 70% of load limit and the surgical flow will not be interrupted
- ROBOTIC ERROR (pop-up window), when the force applied reaches 100% of load limit, an “Unknown Robotic Error” will be triggered, the flow is interrupted and a procedure needs to be followed (see below)



Force Sensor Auto-Recalibration

An “Unknown Robotic Error” will trigger an auto-recalibration of the Force Sensor.

1. Ensure no excessive force is applied to the Robotic Arm.
2. Ensure the red EMERGENCY button is released.
3. Click RESUME to resume the surgery.
4. User will be asked to acknowledge that ROSA is not pinned to the patient and then click on YES button.



13. Post-operative Guide/ Maintenance

13.1 Retrieval of Post-Surgical Log File

13.1.1 Surgeon Report

The Surgeon Report is intended for research purposes and can only be requested by the surgeon.

This report is generated by the ROSA Knee application for each procedure and contains the following information:

- Surgeon name and surgery date
- Case ID and procedure
- Patient gender and age
- Time spent on each surgical step
- Pre-operative plan
- Each set of knee state evaluation data for INITIAL, INTRA-OP and FINAL tabs
- Each set of femoral rotation assessment results
- Intra-operative plan prior to performing the associated bone workflow
- Each validation of cuts data
- Final implant selection

The Surgeon Report will be transferred to a USB drive provided by the surgeon.

To get the Surgeon Report once the surgery is completed:

1. Close the application.
2. Click on the Surgeon Report button associated with the case for the report that is requested.
3. Insert a USB drive in any of the Robotic Unit's USB Ports.
 - Acknowledge that you are the surgeon responsible for this case and click NEXT
 - Enter the PIN associated with the case
 - Click GENERATE

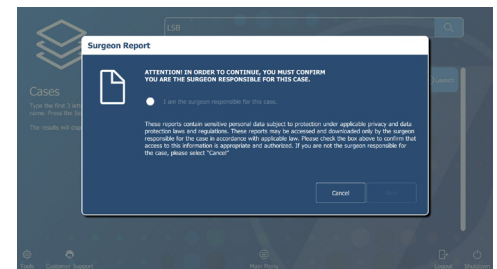
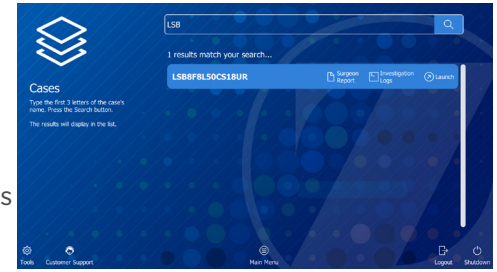

13.1.2 Investigation Logs

The Investigation Logs are intended for the assessment of a specific adverse event or product complaint and can only be requested by a Zimmer Biomet Complaint Handler on behalf of the hospital or surgical team. This report is generated by the ROSA Knee application to provide the entire software logs specific to a patient case under investigation and contains the following information:

- System computers' identification information and list of installed programs
- System computers' logs
- Case specific logs

The Investigation Logs file is securely encrypted and can therefore be transferred to a standard USB drive.

To get the Investigation Logs once the surgery is completed:

1. Close the application.
2. Click on the INVESTIGATION LOGS button associated with the case for which the report is requested.
3. Insert a USB drive into any of the Robotic Unit's USB ports.
4. Acknowledge that the download is related to a specific adverse event or product complaint and click Next.
5. Enter the PIN associated with the case.
6. Click GENERATE.

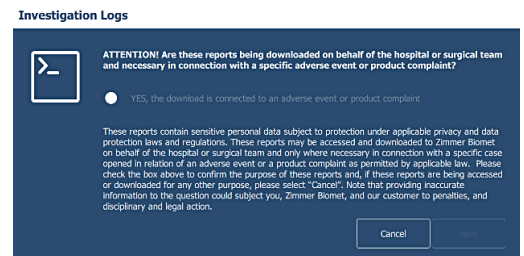

13.2 Shutdown

Click on the MENU button on the left of the bottom task bar. Select QUIT to have the following three options:

- Quit and send Robotic Arm to the PARK position
- Quit only
- Cancel

Risk of collision: When the Robotic Unit is in Automatic mode, stay clear of the Robotic Arm and its path to the next position.



By quitting the ROSA Knee application, the user interface will return to the case management application (refer to section 4.6 Case Management Application). Click SHUTDOWN to power down the device.



Wait 10 seconds after the extinction of the Touchscreen to turn the power switch of the device to “0” for the operating system to shut down properly. Turn the power switch to the “0” position.

To restart the device, wait at least 10 seconds after shutting down and for the RESET button light to turn off.



1. Remove the power cable from the power supply plug.
2. Disconnect the Optical Unit from the Robotic Unit.
3. Clean the Robotic and Optical Units (refer to section 13.3).



All wastes and residues must follow the hospital recycling guidelines.

13.3 Cleaning, Disinfection and Sterilization

13.3.1 Cleaning the Robotic and Optical Units

Make sure the device is turned off and unplugged before cleaning. After each use, clean the covers, panels and the Robotic Arm with a damp cloth.

Use a mild alkaline detergent, if necessary, to remove scuffs and stains. Do not use any solvents that may damage or discolor paint finishes or plastic components. Read the labels of the cleaning products carefully. Both the cloth and the cleaning product must be approved for use in an operating room.

Robotic and Optical Units are not waterproof. Be careful not to spill or splash liquids where they can enter electronic assemblies.



Never attempt to clean the device when it is connected to a power supply. To avoid electrical discharges, always unplug the device from the wall outlet before cleaning or disinfecting it.



IPX0 protection: Device without special protection against the penetration of liquids. Do not pour any liquid over the device.

13.3 Cleaning, Disinfection and Sterilization (cont.)

13.3.2 Cleaning the Optical Camera

Camera Housing

Clean the camera housing only if required. Clean the whole surface of the camera using a lint-free, soft cloth dampened with a non-abrasive and mild detergent.

Illuminator Filters and Lenses

Clean the illuminator filters and lenses only if required. Carefully wipe them using a cloth that is suitable for optical glasses. Remove fingerprints and pay attention not to cause damage or scratches.



13.3.3 Instrument Reprocessing (Cleaning and Sterilization Methods)



Before every surgery, the user must verify that all instruments have been sterilized.



For reusable instruments, also refer to the instrument's package insert.

Section 13.3.3.2 lists the instruments supplied by Zimmer CAS and describes the sterilization methods recommended for each instrument. Reusable instruments must be cleaned after use prior to sterilization. They should not be sterilized in the protective bag or packaging supplied with them. All sterilizations should be performed using standard and regularly maintained equipment. Reusable instruments require the following manual cleaning steps.

1. All multi-components instruments should be disassembled and pre-soaked in an enzyme solution, then scrubbed with a soft bristle brush to remove all visible soil.
2. Use a water jet to flush difficult-to-access areas and closely mated surfaces. For threaded interfaces, screw/unscrew components while flushing the areas.
3. Next, ultrasound cleaning (sonication) in an enzyme solution is recommended in all cases to complete the cleaning steps with minimum cycle times of five minutes and for those instruments with difficult to access areas, cycle times of at least 10 minutes.
4. Finally, in all cases, a thorough rinse is required. Normally, screws and other mechanisms should be checked and lubricated with a medical grade surgical lubricant after each cleaning as determined upon inspection.

The above instructions that are instrument-type dependent are indicated in the ROSA Knee User Manual and Surgical Technique (2300-GLBL-en) as applicable to each instrument.

13.3.3.1 Sterilization Parameters

Steam Sterilization (Autoclave)

Cycle Type	Temperature ¹	Exposure Time ¹	Minimum Dry Time ²	Minimum Cool Time ³
Pre-Vacuum	132 °C (270 °F)	4 minutes	30 minutes	30 minutes

¹ Both the given cycle temperature and time can be increased to 134°C + 3°C (273.2°F + 5.4°F) and 18 minutes according to local requirements outside of the United States such as in the European Union.

² Drying times vary according to load size and should be increased for larger loads.



³ Cooling times vary according to the type of sterilizer used, device design, temperature and humidity of environment, and type of packaging used. Cooling process should comply with ANSI/AAMI ST79.

13.3.3.2 ROSA Knee System Instrument Kit

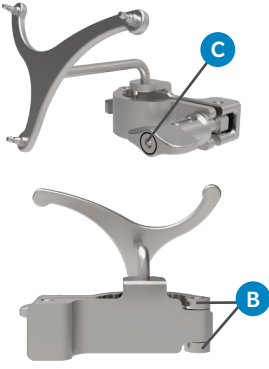
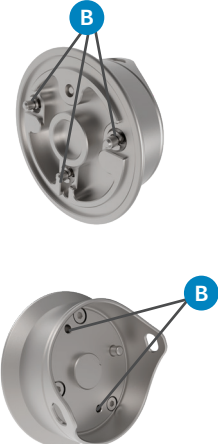

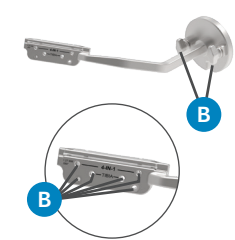

- A. Requires disassembly.
- B. Requires water jet to flush difficult to access areas.
- C. Screw/unscrew components while flushing the area.
- D. Requires a minimum of 10 minutes ultrasonic cleaning cycle in an enzymatic solution.
- E. Screws/mechanisms should be checked and lubricated with a medical grade surgical lubricant after each cleaning as determined upon inspection.

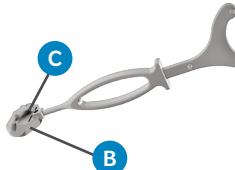
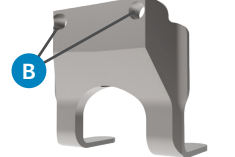
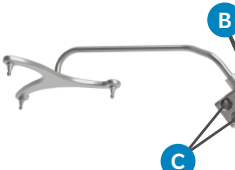
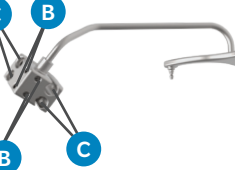
Instrument	Description	Sterilization & specific cleaning instructions	Part Number
	ROSA Base Reference Frame Sterilization & specific cleaning instructions apply both for short and long ROSA Base Reference Frames	Autoclave B C D E	20-8020-002-00
	ROSA Arm Instrument Interface	Autoclave B D E	20-8020-004-00

13.3.3.2 ROSA Knee System Instrument Kit (cont.)

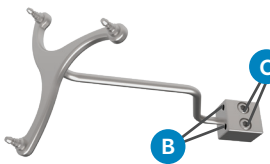
Instrument	Description	Sterilization & Specific Cleaning Instructions	Part Number
	<p>ROSA Persona TKA Cut Guide A ROSA Persona TKA Cut Guide B ROSA NexGen TKA Cut Guide A ROSA NexGen TKA Cut Guide B ROSA Vanguard TKA Cut Guide A ROSA Vanguard TKA Cut Guide B</p>	<p>Autoclave B D E</p>	<p>20-8020-007-00 20-8020-008-00 20-8020-009-00 20-8020-010-00 20-8020-011-00 20-8020-012-00</p>
	<p>ROSA Registration Pointer</p>	<p>Autoclave D</p>	<p>20-8020-013-00</p>
	<p>ROSA Arm Reference Frame</p>	<p>Autoclave B D E</p>	<p>20-8020-015-00</p>
	<p>CAS Universal Validation Tool Body</p>	<p>Autoclave B C D E</p>	<p>20-8000-010-06</p>
	<p>CAS Posterior and Distal Condyles Digitizer</p>	<p>Autoclave B D</p>	<p>20-8000-010-17</p>
	<p>ROSA Tibia Reference A</p>	<p>Autoclave B C D E</p>	<p>20-8020-028-00</p>
	<p>ROSA Tibia Reference B</p>	<p>Autoclave B C D E</p>	<p>20-8020-029-00</p>

13.3.3.2 ROSA Knee System Instrument Kit (cont.)

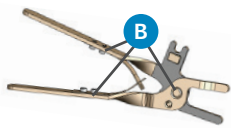
Instrument	Description	Sterilization & Specific Cleaning Instructions	Part Number
	2 Pins Reference Femur – TS3 Offset 2 Pins Reference Right Tibia Size 6	Autoclave B C D E	20-8000-010-33
	Offset 2 Pins Reference Left Tibia Size 6	Autoclave B C D E	20-8000-010-35
		Autoclave B C D E	20-8000-010-36
	Hexagonal Screwdriver 3.5 mm	Autoclave D	00-5120-087-00
	Trocar Pin Screw Driver	Autoclave D	00-5901-021-00
	ROSA Knee Condyle Digitizer (S/M/L)	Autoclave B D	20-8020-190-00 20-8020-191-00 20-8020-192-00
	ROSA Knee Tibia Validation Tool	Autoclave B D	20-8020-193-00
	CAS NavitrackerER Pliers	Autoclave B D E	20-8000-070-05

Disposables

Description	Sterilization & Specific Cleaning Instructions	Part Number
NavitrackerER Kit A - Knee	Provided sterile (single use)	20-8000-000-07
Fixed Fluted Pin 3.2x150 mm	Autoclave (single use)	20-8000-000-01
Fixed Fluted Pin 3.2x80 mm	Autoclave (single use)	20-8000-000-02
Fixed Fluted Pin 3.2x150 mm	Provided sterile (single use)	20-8000-000-10
Fixed Fluted Pin 3.2x80 mm	Provided sterile (single use)	20-8000-000-11
ROSA Checkpoint Screw 13 mm, non-sterile	Autoclave (single use)	20-8020-194-00
ROSA Checkpoint Screw 15 mm, non-sterile	Autoclave (single use)	20-8020-195-00
ROSA Checkpoint Screw 17 mm, non-sterile	Autoclave (single use)	20-8020-196-00
ROSA Checkpoint Screw 13 mm, sterile	Provided sterile (single use)	20-8020-158-00
ROSA Checkpoint Screw 15 mm, sterile	Provided sterile (single use)	20-8020-159-00
ROSA Checkpoint Screw 17 mm, sterile	Provided sterile (single use)	20-8020-160-00

13.3.3.3 ROSA Knee System Instrument Lifetime Expectancy

The reusable instruments of the ROSA Knee System have a lifetime expectancy of five years under normal use, estimated at 240 surgeries over five years. To determine whether a reusable instrument has worn to an extent that it is no longer suitable for use, please refer to the Reusable Instrument Lifespan Manual (1219).

13.4 Storage and Transport

13.4.1 Storage and Protection

13.4.1.1 Device Storage and Protection

At the end of the procedure, the device should be stored in an area fulfilling the storage conditions defined in the technical specifications.

In order to preserve the device, it should be stored in an area where there is no traffic and where it will not be exposed to fluids. The device must not be placed on sloping ground without the assurance of its stability. The immobilization system may be used during storage. During storage, ensure that the Touchscreen is folded above the Robotic Unit so that it is protected in the event of a collision.

13.4.1.2 Instruments Storage and Protection

The instruments shall remain protected from all impacts during handling and storage. Special care shall be taken for all instruments because any damage whatsoever may directly affect the registration accuracy and the positioning accuracy of instruments on a planned trajectory.

13.4.1.3 Care of Cables and Connectors

To avoid damage to cables, make sure the cables are not bent at sharp angles. Handle the connectors with care, paying particular attention to the following points:

- Pull connections apart by gripping the connector. Do not pull them apart by tugging on the cable as this can damage the connecting cable and connector pins
- Do not leave cable connectors where they will get damaged, particularly on the floor, where they can easily be stepped on or rolled over by heavy equipment
- Do not put heavy objects on cables or cable connectors
- Never force a connection



Do not connect any other elements to the Robotic Unit than those provided with the device.



In order to prevent accidental detachment of connector and to ensure EMC protection, make sure that metallic ring of the Optical Unit cable is attached to the hook on the Rear Panel of the Robotic Unit, if applicable.



For safety reasons and to ensure proper functioning of the device, do not use cables other than those distributed by Zimmer Biomet.

13.4.2 Transport

13.4.2.1 Device Transport

When transporting the Robotic Unit, ensure that the Touchscreen is folded above the Robotic Unit so that it is protected in the event of a collision.

When transporting the Optical Unit, ensure that the camera is folded following the indications below so that it is protected in the event of a collision.

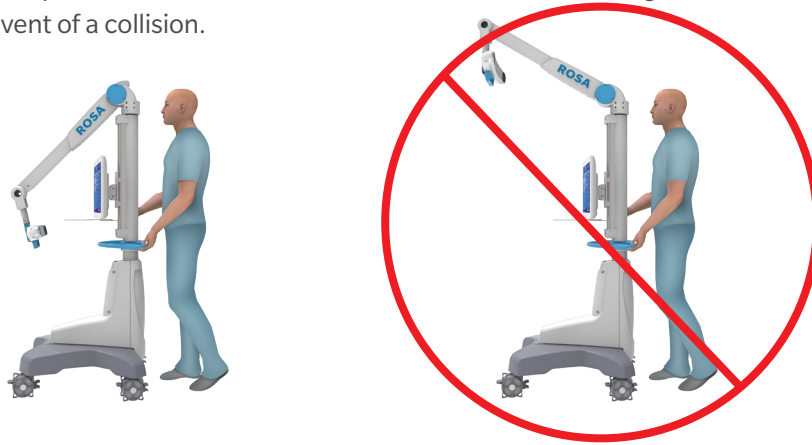

Transporting the device from one site (building) to another is performed only under the responsibility of the user. Any damages or malfunctions caused during transportation are not covered by Zimmer Biomet.

 During transportation, the device can be immobilized by activating the immobilization pedal. Do not install the device on an inclined surface, unless its stability is guaranteed.

 Activate all wheels brakes of the Optical Unit to ensure its immobilization.

 Transportation or displacement of the device can be handled by one person.

13.4.2.2 Transport of ROSA Checkpoint Screws

ROSA Checkpoint Screws (Non-Sterile) must be placed between the pin brackets in the ROSA Pin Caddy for transportation.

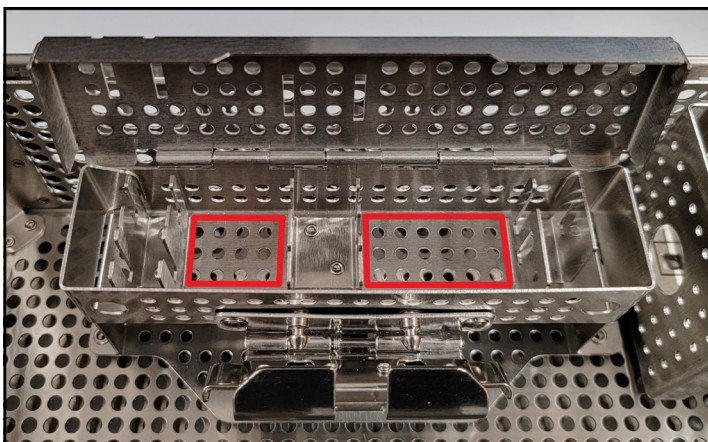

13.5 Maintenance Operations

13.5.1 Installation

The device is installed on site by Zimmer Biomet personnel only or by its approved representatives. The installation requires expert knowledge of the device by the personnel.

13.5.2 Daily Checks

Regularly perform a safety check of the device. Inspect the device to ensure no defects appear on the:

- Robotic Unit, including the Robotic Arm
- Optical Unit
- Optical Camera
- Force Sensor Connector
- Immobilization system and locks of Robotic Unit
- Foot Pedal
- Instruments

These safety checks are recommended to be done each day of use. Check the physical condition of the instruments to ensure no defects are present. Never use a distorted or damaged component.

13.5.3 Periodic Maintenance

A maintenance agreement is established between the customer and Zimmer Biomet. It covers the frequency of the preventive maintenances and list the different checks and tests performed. Maintenance play a preventive role in possible issues that may arise with the product use.

Zimmer Biomet Customer Service is committed to handling any operation defaults that may appear on the device.

Zimmer Biomet will provide, on demand, schematic diagrams, calibration information and other information necessary to perform maintenance technical tasks, identified as being able to be performed by service personnel.



Do not open the device. In case of any issue or breakdown, do not intervene. Maintenance and service operations must only be carried out by Zimmer Biomet's Customer Service or any of its approved representatives. Do not modify the device.



When used in compliance with the indications for maintenance, the device can be run in permanent operation.

13.6 Troubleshooting

Issue	Cause	Solution
The device does not turn on	The Power Cable is unplugged	Check that the Power Cable is connected
	The ON/OFF switch is turned to OFF	Turn the switch located on the Rear Panel of the device to ON
	Electric current is cut off by an external circuit breaker	Press on the CIRCUIT BREAKER button to reset it
	Electric current is cut off by an internal circuit breaker	Contact Zimmer Biomet Customer Service
The Touchscreen does not work	The screen is off	Turn the Touchscreen on by pressing on the button to the right side of the screen
	The screen Power Cable is unplugged	Ensure that the power, video and USB Touchscreen cables are connected
	The video cable is unplugged	
	The USB cable is unplugged	
	The screen displays the message “No video input” and then goes black. The RESET button indicator located on the Rear Panel of the device is red	Press the RESET button on the Rear Panel of the device and check that the RESET button indicator is blue
	The actions of the application do not correspond to the buttons activated. The Touchscreen is not calibrated	Contact Zimmer Biomet Customer Service
	The Touchscreen behavior is sporadic, i.e. some touches on the screen are not working	Contact Zimmer Biomet Customer Service
The CD/DVD reader does not operate	CD/DVD is unplugged and non-functional	CD/DVD cannot be used
A USB port does not work	USB port faulty	Try another USB port. Inform Zimmer Biomet Customer Service
	Connection problem with the USB port	
Case data cannot be uploaded with the USB drive	Case data is corrupted	Download the case data on the USB drive and sync again with the device. If unsuccessful, switch to imageless
	USB drive is faulty	





13.6 Troubleshooting (cont.)

Issue	Cause	Solution
The Robotic Unit immobilization system does not work	The immobilization pedal cannot go through its full range down to its locked position	Check that there is no obstacle under the stabilization feet
The Robotic Arm movement is interrupted	The device indicates detection of a collision. An unsuitable tool is installed on the Robotic Arm. The tool does not correspond to the current stage in the procedure	Ensure that the tool installed corresponds to the current stage in the procedure. Restart the movement
	The device indicates that the user interrupted movement. The Foot Pedal is turned off	Check that the Foot Pedal is connected into the Rear Panel of the device
	The light on the RESET button on the Rear Panel of the device is off and the Foot Pedal doesn't work	Contact Zimmer Biomet Customer Service
The Robotic Arm drifts slowly in Collaborative mode	An unsuitable tool is installed on the Robotic Arm. The tool does not correspond to the current stage in the procedure	Stop the Collaborative mode. Check that the tool installed corresponds to the current stage of the procedure. Launch the Collaborative mode once again
	The tool is in contact with an object	Ensure that the elements secured to the Robotic Arm are not in contact with an external object
	The calibration of the Force Sensor has not been well performed	Go back to SETUP panel, SENSOR & DRAPING sub-panel and perform the calibration of the Force Sensor ensuring no instrument is installed and no force is applied on the Robotic Arm
The interface displays a communication error message with the Robotic Unit	The Force Sensor Cable is unplugged	Connect the cable to the Force Sensor. Restart the device
	The red EMERGENCY button has been activated and the Robotic Unit remains off	Deactivate the red EMERGENCY button and restart the device

13.6 Troubleshooting (cont.)

Issue	Cause	Solution
The registration is unsuccessful	Trackers not seen	Make sure the trackers are visible during the registration
	Movement of the Robotic Unit	Verify that the Robotic Unit is immobilized (each wheel and the main immobilization system) during the registration
	Movement of the camera	Verify that the Optical Unit is immobilized during the registration
	ROSA Base Reference Frame was not installed properly	Make sure the ROSA Base Reference Frame is firmly secured
	ROSA Arm Reference Frame was not installed properly	Make sure the ROSA Arm Reference Frame is firmly secured
	ROSA Arm Instrument Interface was not installed properly	Make sure the ROSA Arm Instrument Interface is firmly secured
	NavitrackER devices were not installed properly	Make sure the NavitrackER devices are fully seated on the instruments
The Cut Guide checkpoint is unsuccessful	Wrong Cut Guide installed	Check that you have the right Cut Guide family (Persona, NexGen, Vanguard) and laterality (A or B)
	Cut Guide is loosely installed	Check that the ROSA TKA Cut Guide and Arm Instrument Interface are firmly secured
	ROSA Base Reference Frame has moved	Redo registration
The Bone Reference Checkpoint is unsuccessful	Bone has been stripped at installation, screw is not stable	Reinstall the Bone Checkpoint Screw, and reacquire associated landmark OR Dismiss Bone Reference Checkpoint acquisition
	A bone reference or NavitrackER has moved since bone reference checkpoint acquisition	Before cut: secure bone reference, reacquire all landmarks, perform Knee State Evaluation and Planning again OR During cut: switch to conventional instrumentation
The red EMERGENCY button light is on	The red EMERGENCY button has been activated	Release the red EMERGENCY button and restart the device
	The Foot Pedal triggered an error	Shut down the device and restart

13.6 Troubleshooting (cont.)

-  The device requires specific precautions regarding the EMC. It must be installed and operated according to the EMC information provided in the User Manual.
-  Portable and mobile radio frequency communication devices might affect the operation of the device.
-  Usage of accessories, transducers and cables other than those specified in the User Manual, with the exception of the transducers and cables sold by Zimmer Biomet (as spare parts of internal components), might cause increased emissions or decrease immunity of the device.
-  The device must not be used adjacent to or stacked on top of any other equipment. If inevitable, verify its perfect operation in the corresponding configuration.

13.7 Safe Disposal

The instruments and their components are subject to wear and therefore, have to be considered as non-durable material. The integrity of the instruments has to be checked before use and if necessary, instruments must be returned to the responsible local representative for repair or disposal.

After use, all wastes and residues must follow the hospital recycling guidelines. Special attention must be paid to instruments that could be potential biohazards, since they may be contaminated with blood or other body fluids, bone or other tissue. Handle and dispose these products in accordance with accepted medical practice and with applicable local, state and national laws and regulations.

14. Product Security Customer Control Considerations

14.1 Records Retention & Purging Historical Data

The ROSA Recon platform will be located at the Healthcare Delivery Organization (HDO) facility and is subject to the regulatory requirements and records retention period. After this period and upon request by the HDO, Zimmer Biomet field service engineers will assist the HDO with purging historical data from the ROSA Recon platform.

14.2 Physical & Environmental Security Controls

The ROSA Recon platform will be located at the Healthcare Delivery Organization (HDO) facility and is subject to the HDO's physical and environmental safeguards to mitigate the risks of loss, theft and physical tampering. The ROSA Recon platform should be stored in a location at the HDO with physical access control to authorized personnel only when not in use.

15. Technical Data

15.1 Labels & Symbols

15.1.1 Labels

The device labels affixed on the device components are detailed below. Bar codes and 2D Matrix are examples only.

System	Countries	Robotic Unit Label Example
110V	US, Canada, Taiwan	
220V	Australia, Austria, Belgium, China, France, Germany, Greece, Hong Kong, India, Israel, Italy, Netherlands, New Zealand, Singapore, Spain, Switzerland, UAE, UK.	

* The countries list is not exhaustive and only provides examples where the platform could be used. Please contact your local support to determine availabilities in your region.

15.1.1 Labels (cont.)

System	Countries	Robotic Unit Label Example
100V	Japan	

* The countries list is not exhaustive and only provides examples where the platform could be used. Please contact your local support to determine availabilities in your region.



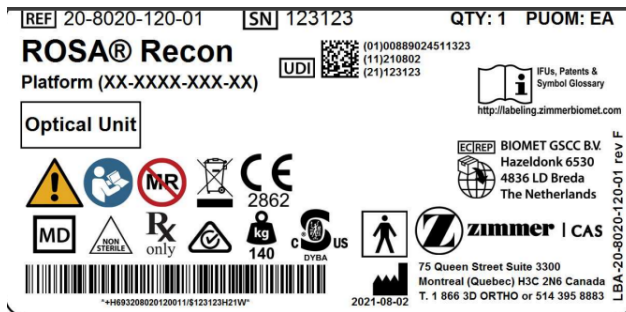





Optical Unit Label Example



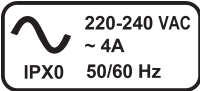
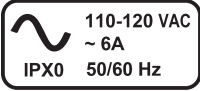
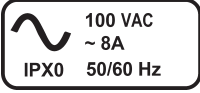









Translation Label Examples

System	Robotic Unit Label Example
<p>Robotic Unit 110V</p>	<div style="border: 1px solid black; padding: 10px;"> <p>REF 20-8020-110-01 SN 123123</p> <p>EN Recon Platform Robotic Unit 110V Robotic Unit 110V</p> <p>FR Unité robotisée Recon Platform 110 V Station robotique 110V</p> <p>IT Unità robotica piattaforma di ricostruzione 110 V Unità robotica 110V</p> <p>DE Recon-Plattform Robotikeinheit 110 V Robotereinheit 110V</p> <p>ES Unidad robótica de la plataforma Recon 110 V Unidad robótica 110V</p> <p style="text-align: right; font-size: small;">LBB-20-8020-110-01 rev B</p> </div>
<p>Robotic Unit 220V</p>	<div style="border: 1px solid black; padding: 10px;"> <p>REF 20-8020-110-26 SN 123123</p> <p>EN Recon Platform Robotic Unit 220V Robotic Unit 220V</p> <p>FR Unité robotisée Recon Platform 220 V Station robotique 220V</p> <p>IT Unità robotica piattaforma di ricostruzione 220 V Unità robotica 200V</p> <p>DE Recon-Plattform Robotikeinheit 220 V Robotereinheit 220V</p> <p>ES Unidad robótica de la plataforma Recon 220 V Unidad robótica 220V</p> <p style="text-align: right; font-size: small;">LBB-20-8020-110-26 rev B</p> </div>
<p>Robotic Unit 100V</p>	<div style="border: 1px solid black; padding: 10px;"> <p>REF 20-8020-110-17 SN 123123</p> <p>EN Recon Platform Robotic Unit 100V Robotic Unit 100V</p> <p>FR Unité robotisée Recon Platform 100 V Station robotique 100V</p> <p>IT Unità robotica piattaforma di ricostruzione 100 V Unità robotica 100V</p> <p>DE Recon-Plattform Robotikeinheit 100 V Robotereinheit 100V</p> <p>ES Unidad robótica de la plataforma Recon 100 V Unidad robótica 100V</p> <p style="text-align: right; font-size: small;">LBB-20-8020-110-17 rev B</p> </div>
<p>Optical Unit</p>	<div style="border: 1px solid black; padding: 10px;"> <p>REF 20-8020-120-01 SN 123123</p> <p>EN Recon Platform Optical Unit Optical Unit</p> <p>FR Unité optique Recon Platform Station optique</p> <p>IT Unità ottica piattaforma di ricostruzione Unità ottica</p> <p>DE Recon-Plattform optische Einheit Optikeinheit</p> <p>ES Unidad óptica de la plataforma Recon Unidad óptica</p> <p style="text-align: right; font-size: small;">LBB-20-8020-120-01 rev B</p> </div>











15.1.2 Symbols on the Labels

Label	Symbol title	Description
	General warning sign	Indicates a general warning
	Refer to instruction manual/ booklet	Indicates that the instruction manual/booklet must be read
 IFUs, Patents & Symbol Glossary http://labeling.zimmerbiomet.com	Consult electronic instructions for use	Indicates the need for the user to consult the instructions for use available online at the website mentioned below the graphic
	Power supply specifications	Power supply specifications for concerned countries (ex: Germany, France) IPX0: No protection against liquids
	Power supply specifications	Power supply specifications for concerned countries (ex: U.S., Canada) IPX0: No protection against liquids
	Power supply specifications	Power supply specifications for concerned countries (Japan) IPX0: No protection against liquids
	Type BF applied part	BF type device. Indicates a higher degree of protection against electric shock. This medical device is floating and do not have connections with ground. It meets the patient leakage current requirements
	Magnetic Resonance (MR) Unsafe	Indicates a medical device that poses unacceptable risks to the patient, medical staff or other persons within a Magnetic Resonance environment. MR Unsafe: Keep away from Magnetic Resonance Imaging (MRI) equipment
	Prescription Only	Indicates that Federal law restricts this device to sale by or on the order of a physician
	European market authorization	Indicates that the product conforms to EU Medical Device Regulation
	Curtis-Straus NRTL/SCC Certification Mark	Indicates that Bureau Veritas/Curtis-Straus nationally recognized testing laboratories mark, with "US" and "C" identifiers, for U.S. & Canada for NRTL/SCC certification
	Unique Device Identifier	Indicates a carrier that contains unique device identifier information







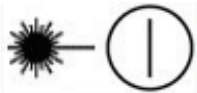

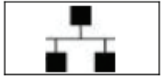

15.1.2 Symbols on the Labels (cont.)

Label	Symbol title	Description
	Regulatory Compliance Mark (RCM) for Australia and New Zealand.	Indicates that the medical device complies with the requirements of the electrical and EMC regulations of Australia and New Zealand Regulatory Compliance Mark (RCM) for Australia and New Zealand
	Non-sterile	Indicates a medical device that has not been subjected to a sterilization process
	Manufacturer	Indicates the medical device manufacturer
	Date of manufacture	Indicates the date when the medical device was manufactured
	Authorized representative in the European Community/ European Union	Indicates the authorized representative in the European Community/European Community
	Importer	Indicates the entity importing the medical device into the locale
	Catalogue number	Indicates the manufacturer's catalogue number so that the medical device can be identified
	Serial number	Indicates the manufacturer's serial number so that a specific medical device can be identified
	Kg Device Weight	Indicates device weight in kilogram(s)
	Recycle: Electronic Equipment	Indicates that the equipment should not be discarded as unsorted waste but must be sent to separate collection facilities for recovery and recycling

15.1.3 Other Symbols on the Device

Label	Symbol title	Description
	Bottom of Robotic Unit Rear Panel	OFF – Switch off the device
	Bottom of Robotic Unit Rear Panel	ON – Switch on the device
	Bottom of Robotic Unit Rear Panel	Central unit RESTART button
	Bottom of Robotic Unit Rear Panel	Foot Pedal socket
	Bottom of Robotic Unit Rear Panel	Socket for black RJ45 cable of Optical Unit wiring
	Bottom of Robotic Unit Rear Panel	Socket for white RJ45 cable of Optical Unit wiring
	Bottom of Robotic Unit Rear Panel	Socket for Optical Unit main cord
	Bottom of Robotic Unit Rear Panel	Controller servicing port (deactivated)
	Bottom of Robotic Unit Rear Panel	Robotic Unit immobilization system move lever up/down to unlock/lock
	Bottom cover of Robotic Unit, above stabilization feet	Risk of foot crushing
	Middle of Robotic Unit Rear Panel	Distance sensor on/off symbol Not applicable for Knee application (deactivated)

15.1.3 Other Symbols on the Device (cont.)

Label	Location	Description
	Camera handle on Optical Unit	Optical sensor laser pointer ON/OFF symbol. OFF is a stable position, while the ON position only remains during the time the button is depressed
	Middle of Robotic Unit Rear Panel	USB port
	Middle of Robotic Unit Rear Panel	Ethernet port symbol. Not applicable for Knee application (deactivated)
	Middle of Robotic Unit Rear Panel	Do not use USB ports for charging a cell phone. Connection for USB drive, keyboard and mouse only
	Middle of Robotic Unit Rear Panel	Do not use USB ports for connecting a wireless device. Connection for USB drive, keyboard and mouse only
	Top cover of Robotic Unit	Emergency stop
	Rear of Touchscreen on Robotic Unit	Stored energy hazard
	Optical Unit	Lock Optical Unit in place using the brake on all four wheels
	Optical Unit	Fold the camera arm for transportation
	Rear of camera on the right	Laser beam – Never look directly at the laser beam – Class II laser
		

15.2 Technical Specifications

15.2.1 Environmental Specifications

Environment	Storage and Transportation	Operating
Temperature	0°C to 50°Celsius	15°C to 35°Celsius
Humidity	8% to 93% (without condensation)	8% to 75% (without condensation)
Air pressure	800 hPa to 1060 hPa	800 hPa to 1060 hPa

15.2.2 Device Performance

Device performance	Value
Robotic Arm positioning accuracy	< 0.75 mm RMS

15.2.3 Device Dimensions

The device has the following exterior dimensions in millimeters:

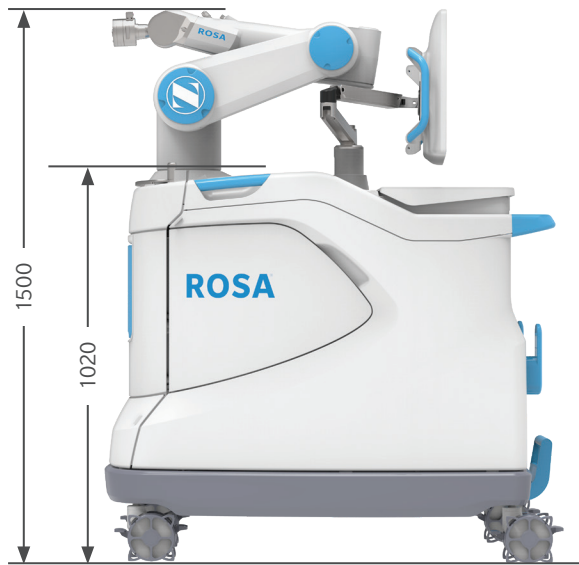

Robotic Unit Dimensions

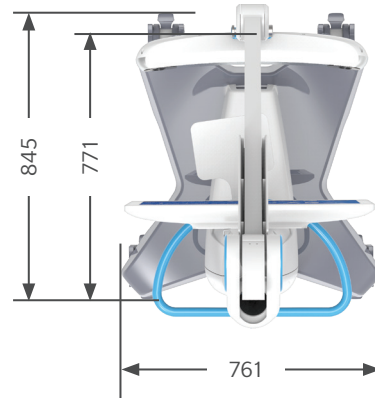
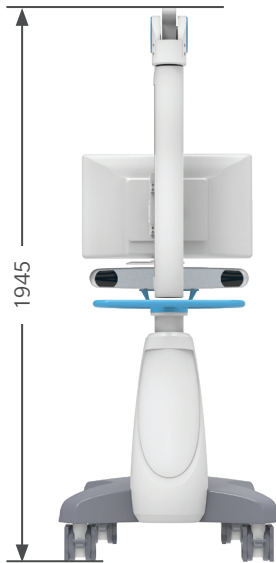

Optical Unit Dimensions

Robotic Unit weight: Approximately 320kg (705 lb)

Optical Unit weight: Approximately 140 kg (309 lb)

15.2.4 Robotic Arm Working Range

ROSA Knee is equipped with a Stäubli 6-axis Robotic Arm and has 6° of freedom.

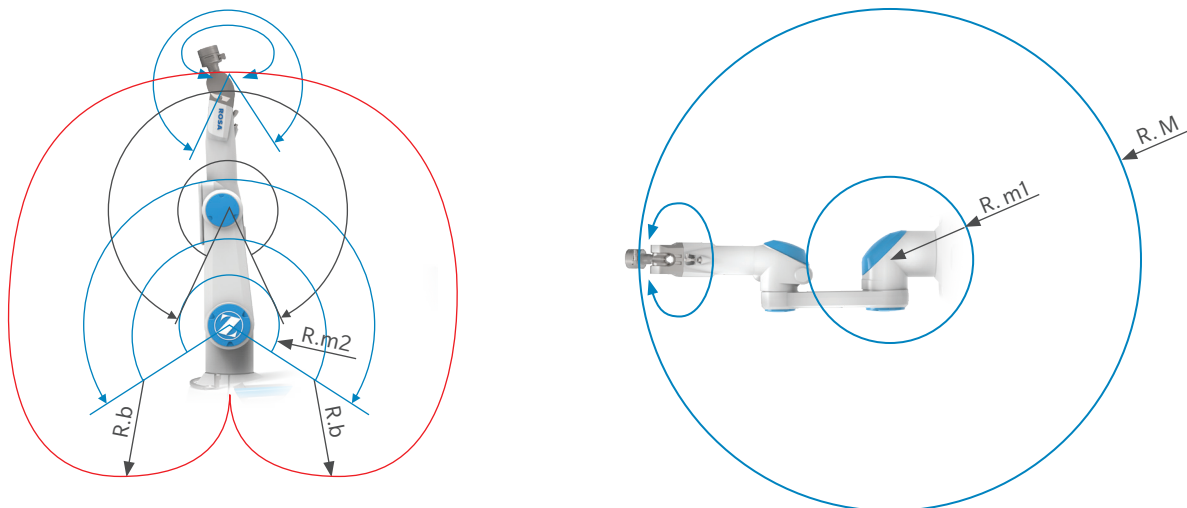

Robotic Arm Working Range

Dimension	Value
Maximum radius between joint 1 and 5 (R.M)	850 mm
Minimum radius between joint 1 and 5 (R.m1)	209 mm
Minimum radius between joint 2 and 4 (R.m2)	208 mm
Minimum radius between joint 3 and 5 (R.b)	450 mm

15.3 Safety Classification & Standards

Type	Classification
Protection against electric shock	Class 1 Patient protection = type BF applied part
Protection against ingress of fluids	Robotic Unit = IPX0 Optical Unit = IPX0 Footswitch = IP68
Protection against laser beam	Navigation camera = Class 2

15.3 Safety Classification & Standards (cont.)

Standard	Description
IEC 60601-1	Medical electrical equipment – Part 1: General requirements for basic safety and essential performances
IEC 60601-1-2	Medical electrical equipment – Part 1-2: General requirements for basic safety and essential performances – Collateral Standard: Electromagnetic Compatibility
IEC 60601-1-6	Medical devices – Part 1-6: General requirement for basic safety and essential performance – Usability
IEC 62366-1	Medical devices – Part 1: Application of usability engineering to medical devices
ISO 17664	Sterilization of medical devices – Information to be provided by the manufacturer for the processing of resterilizable medical devices
ISO 17665-1	Sterilization of healthcare products – Moist heat-Part 1: Requirements for the development, validation and routine control of a sterilization process for medical devices
ISO 10993-1	Biological evaluation of medical devices – Part 1: Evaluation and testing within a risk management process
IEC 62304	Medical device software – Software life cycle process
IEC 60825-1	Safety of laser products – Part 1: Equipment classification and requirements

15.3.1 Cable Lengths

Cable and Accessories	Maximum Length	Type of Test	In Accordance With
Power Cable Foot Pedal Cable	>3m >3m	RF Emissions	CISPR, Class A
		Harmonic current	IEC 61000-3-2
		Voltage fluctuations/flicker	IEC 61000-3-3
Optical Unit main cord Force Sensor Cable	>3m <3m	Electrostatic discharge immunity	IEC 61000-4-2
		Radiated immunity – electromagnetic fields	IEC 61000-4-3
		Electrical fast transient/ burst immunity test	IEC 61000-4-4
		Surge immunity test	IEC 61000-4-5
		Conducted immunity – Conducted RF	IEC 61000-4-6
		Radiated immunity – Magnetic field	The electromagnetic field strengths of fixed radio frequency transmitters
		Downtimes, dips and variation of the power supply voltage	

15.4 Electromagnetic Compatibility

All the information below is based on the normative requirements to which the manufacturers of Electrical Medical devices are subjected to, in regards with IEC60601-1-2. The medical device complies with applicable electromagnetic compatibility standards, however, the user will ensure that any electromagnetic interference does not create an additional hazard, such as radio frequency transmitters or other electronic devices. In this section, you will find information necessary to ensure the installation and commissioning of your medical device under the best conditions in terms of electromagnetic compatibility.

The different cords of the medical device must be separated from each other. Certain types of mobile telecommunication devices, such as mobile phones, are likely to interfere with the medical device. The separation distances recommended in this chapter must therefore be strictly observed. The medical device must not be used near or on another device. If this cannot be avoided, it must be checked for proper operation under the conditions of use before use. The use of accessories other than those specified or sold by Zimmer CAS as replacement parts, may result in an increase in the emission or a reduction of the immunity of the medical device.

15.4.1 Electromagnetic (EM) Emissions

The device has been designed for use in an electromagnetic environment as specified below. The user must ensure that it operates in this type of environment.

Emission trials	Conformity	Electromagnetic Environment - Guide
RF emissions CISPR 11 ⁽¹⁾	Group 1	The ROSA Recon platform is part of CISPR11 group 1. The ROSA Recon platform uses RF energy as below: Wi-Fi in the 2.4 GHz band (2400 to 2483,5MHz) or in the 5.0GHz band (5150 to 5250MHz; 5250 to 5350MHz and 5470 to 5725MHz) as a mean of radio communication (5GHz band being restricted to indoor use only). Emission powers in the 2.4GHz band do not exceed 19.92dBm, compliant with ETSI EN 300 328. Emission powers in the 5.0GHz band do not exceed 22.97dBm, compliant with ETSI EN 301 893. The device uses 2 dipole antennas.
RF emissions CISPR 11 ⁽¹⁾	Class A	This equipment has been tested and found to comply with the limits for a Class A digital device, pursuant to part 15 of the FCC Rules. These limits are designed to provide reasonable protection against harmful interference when the equipment is operated in a commercial environment. This equipment generates, uses, and can radiate radio frequency energy and, if not installed and used in accordance with the instruction manual, may cause harmful interference to radio communications. Operation of this equipment in a residential area is likely to cause harmful interference in which case the user will be required to correct the interference at his own expense.

⁽¹⁾The emission characteristics of this device make it suitable for use in industrial areas and hospitals (class A defined in CISPR 11). When used in a residential environment (for which class B defined in CISPR 11 is normally required), this device may not provide adequate protection for radio frequency communications services. The user may need to take mitigation measures, such as relocating or reorienting of the device.

Ensuring that the system operates in the above environment will maintain basic safety and essential performance with regard to electromagnetic disturbances for the expected service life.

15.4.1 Electromagnetic (EM) Emissions (cont.)



BE	LU	NL	FR	DE
IT	DK	IE	UK	EL
ES	PT	AT	FI	SE
CY	EE	HU	LV	LT
MT	PL	SI	SK	CZ
BG	RO	HR		
NO	CH	IS	LI	

Reference	Performance Specification	If Lost or Degraded due to EM Disturbances
Essential Performance 1	Accurate information display	Information display not accurate
Essential Performance 2	Accurate robot Positioning	Robot positioning not accurate
Basic Safety 1	Collision detection	Collision detection feature affected
Basic Safety 2	No unwanted robot motion	Unwanted robot motion could occur

Using the ROSA Knee System with other products or components unless such other products or components are expressly recognized as compatible with the system could affect basic safety and essential performance in terms of EM disturbances.

15.4.2 Electromagnetic and Magnetic Immunity

The device has been designed for use in an electromagnetic environment, such as specified below. The user must ensure that it operates in this type of environment.

Electromagnetic Immunity

ROSA Knee is intended for use in a professional healthcare facility environment. The user of ROSA Knee should assure that it is used in such an environment.

Immunity Test	IEC 60601-1-2 Test Level	Compliance Level of ROSA Knee	Electromagnetic Environment Guide
Electrostatic discharge (ESD) EN 61000-4-2	±8 kV contact (direct, indirect horizontal, indirect vertical) ±2 kV, ±4 kV, ±8 kV, ±15 kV air	±8 kV contact ±2 kV, ±4 kV, ±8 kV, ±15 kV air	Main power quality should be that of a professional healthcare facility environment

15.4.2 Electromagnetic and Magnetic Immunity (cont.)

Immunity Test	IEC 60601-1-2 Test Level	Compliance Level of ROSA Knee	Electromagnetic Environment Guide
Electrical fast transient/burst Signal input/output parts PORT (L> 3m) IEC 61000-4-4	± 1 kV/100 Hz	± 1 kV/100 Hz	Main power quality should be that of a professional healthcare facility environment
Electrical fast transient/burst Input a.c power PORT IEC 61000-4-4	± 2 kV/ 100 Hz	± 2 kV/ 100 Hz	
Surge Input a.c power PORT IEC 61000-4-5	$\pm 0,5$ kV, ± 1 kV line to line $\pm 0,5$ kV, ± 1 kV, ± 2 kV line to ground	$\pm 0,5$ kV, ± 1 kV line to line $\pm 0,5$ kV, ± 1 kV, ± 2 kV line to ground	Main power quality should be that of a professional healthcare facility environment
Voltage dips Input a.c power PORT EN 61000-4-11	0% U_T for 0.5 cycles At 0°, 45°, 90°, 135°, 180°, 225°, 270° and 315° 0% U_T for 1 cycles and 70% U_T for 25\30 cycles (500ms) Single phase: at 0°	0% U_T for 0,5 cycle at 0°, 45°, 90°, 135°, 180°, 225°, 270° and 315° <5% U_T (>95% dip in U_T) for 0,5 cycle 0% U_T for 1 cycle and 70% U_T for 25/30 cycles (500ms) Single phase: at 0°	Main power quality should be that of a professional healthcare facility environment. If the user of device requires continued operation during power outages, it is recommended that the device be powered from an uninterruptible power supply or a battery
Voltage interruptions EN 61000-4-11	0 % U_T For 250\300 cycles	0 % U_T For 250\300 cycles	
RATED power frequency (50\60 Hz) magnetic field Enclosure port IEC61000-4-8	30 A/m ^a 50 Hz and 60 Hz	30 A/m ^a 50 Hz and 60 Hz	Power frequency magnetic fields should be at levels characteristic of a professional healthcare facility environment

Note: U_T is the a.c. main voltage prior to application of the test level.

^a Using a minimum distance of 15 cm between the ROSA Knee device and source of power frequency magnetic field.

15.4.3 Electromagnetic Immunity and Portable and Mobile Radio Frequency (RF) Communication Equipment

Electromagnetic Immunity Conducted and Radiated RF

ROSA Knee is intended for use in a professional healthcare facility environment. The user of ROSA Knee should assure that it is used in such an environment.

Immunity Test	IEC 60601 Test Level	Compliance Level of ROSA Knee	Electromagnetic Environment Guide
Conducted disturbances induced by RF fields Signal input/output parts PORT (L > 0m) IEC 61000-4-6	3 V 150 kHz to 80 MHz 6V in ISM ^d band and band between 0.15MHz and 80MHz including amateur radio band 80% MA at 1KHz	3 V 150 kHz to 80 MHz 6V in ISM ^d band and band between 0.15MHz and 80MHz including amateur radio band 80% MA at 1KHz	Main power quality should be that of a professional healthcare facility environment Warning: Portable and mobile RF communications equipment (including peripherals, such as antenna cables and external antennas) should be used no closer than 30 cm (12 inches) to any part of the ROSA Knee device, including cables specified by the manufacturer Otherwise, degradation of the performance of this equipment could result
Conducted disturbances induced by RF fields input a.c power PORT IEC 61000-4-6	3 V 150 kHz to 80 MHz 6V in ISM ^d band and band between 0.15MHz and 80MHz including amateur radio band 80% MA at 1KHz	3 V 150 kHz to 80 MHz 6V in ISM ^d band and band between 0.15MHz and 80MHz including amateur radio band 80% MA at 1KHz	
Radiated RF electromagnetic field IMMUNITY Enclosure port IEC 61000-4-3	3 V/m 80 MHz to 2.7 GHz 80% AM at 1 kHz	3 V/m 80 MHz to 2.7 GHz 80% AM at 1 kHz	
IMMUNITY to proximity fields from RF wireless communications equipment Enclosure port IEC 61000-4-3	385MHz/ 27V/m 450 MHz/ 28V/m 710 MHz/ 9V/m 745 MHz/ 9V/m 780 MHz/ 9V/m 810 MHz/ 28V/m 870 MHz/ 28V/m 930 MHz/ 28V/m 1720 MHz/ 28V/m 1845 MHz/ 28V/m 1970 MHz/ 28V/m 2450 MHz/ 28V/m 5240 MHz/ 9V/m 5500 MHz/ 9V/m 5785 MHz/ 9V/m	385 MHz/ 27V/m 450 MHz/ 28V/m 710 MHz/ 9V/m 745 MHz/ 9V/m 780 MHz/ 9V/m 810 MHz/ 28V/m 870 MHz/ 28V/m 930 MHz/ 28V/m 1720 MHz/ 28V/m 1845 MHz/ 28V/m 1970 MHz/ 28V/m 2450 MHz/ 28V/m 5240 MHz/ 9V/m 5500 MHz/ 9V/m 5785 MHz/ 9V/m	

^dThe ISM (Industrial Scientific and Medical) bands between 150 kHz and 80 MHz are 6.765 MHz to 6.795 MHz; 13.553 MHz to 13.567 MHz; 26.957 MHz to 27.283 MHz; and 40.66 MHz to 40.70 MHz.

15.4.4 Recommended Separation Distances

The ROSA Knee device is intended for use in an electromagnetic environment in which radiated RF disturbances are controlled. The user or installer of the medical device can help to avoid electromagnetic interference by maintaining a minimum distance, depending on the maximum power of the radio frequency transmission equipment. RF portable communications equipment (including peripherals such as antenna cables and external antennas) should not be used closer than 30 cm (12 inches) to any part of the ROSA Knee device, including the cables specified by the manufacturer. Otherwise, the performance of these devices may be impaired.

16. Software Licenses

16.1 Boost

Boost Software License - Version 1.0 - August 17th, 2003

Permission is hereby granted, free of charge, to any person or organization obtaining a copy of the software and accompanying documentation covered by this license (the "Software") to use, reproduce, display, distribute, execute, and transmit the Software, and to prepare derivative works of the Software, and to permit third-parties to whom the Software is furnished to do so, all subject to the following:

The copyright notices in the Software and this entire statement, including the above license grant, this restriction and the following disclaimer, must be included in all copies of the Software, in whole or in part, and all derivative works of the Software, unless such copies or derivative works are solely in the form of machine-executable object code generated by a source language processor.

THE SOFTWARE IS PROVIDED "AS IS", WITHOUT WARRANTY OF ANY KIND, EXPRESS OR IMPLIED, INCLUDING BUT NOT LIMITED TO THE WARRANTIES OF MERCHANTABILITY, FITNESS FOR A PARTICULAR PURPOSE, TITLE AND NON-INFRINGEMENT. IN NO EVENT SHALL THE COPYRIGHT HOLDERS OR ANYONE DISTRIBUTING THE SOFTWARE BE LIABLE FOR ANY DAMAGES OR OTHER LIABILITY, WHETHER IN CONTRACT, TORT OR OTHERWISE, ARISING FROM, OUT OF OR IN CONNECTION WITH THE SOFTWARE OR THE USE OR OTHER DEALINGS IN THE SOFTWARE

16.2 VTK

Copyright (c) 1993-2015 Ken Martin, Will Schroeder, Bill Lorensen

All rights reserved.

Redistribution and use in source and binary forms, with or without modification, are permitted provided that the following conditions are met:

- Redistributions of source code must retain the above copyright notice, this list of conditions and the following disclaimer.
- Redistributions in binary form must reproduce the above copyright notice, this list of conditions and the following disclaimer in the documentation and/or other materials provided with the distribution.
- Neither name of Ken Martin, Will Schroeder, or Bill Lorensen nor the names of any contributors may be used to endorse or promote products derived from this software without specific prior written permission.

THIS SOFTWARE IS PROVIDED BY THE COPYRIGHT HOLDERS AND CONTRIBUTORS "AS IS" AND ANY EXPRESS OR IMPLIED WARRANTIES, INCLUDING, BUT NOT LIMITED TO, THE IMPLIED WARRANTIES OF MERCHANTABILITY AND FITNESS FOR A PARTICULAR PURPOSE ARE DISCLAIMED. IN NO EVENT SHALL THE AUTHORS OR CONTRIBUTORS BE LIABLE FOR ANY DIRECT, INDIRECT, INCIDENTAL, SPECIAL, EXEMPLARY, OR CONSEQUENTIAL DAMAGES (INCLUDING, BUT NOT LIMITED TO, PROCUREMENT OF SUBSTITUTE GOODS OR SERVICES; LOSS OF USE, DATA, OR PROFITS; OR BUSINESS INTERRUPTION) HOWEVER CAUSED AND ON ANY THEORY OF LIABILITY, WHETHER IN CONTRACT, STRICT LIABILITY, OR TORT (INCLUDING NEGLIGENCE OR OTHERWISE) ARISING IN ANY WAY OUT OF THE USE OF THIS SOFTWARE, EVEN IF ADVISED OF THE POSSIBILITY OF SUCH DAMAGE.

16.3 GDCM

Program: GDCM (Grassroots DICOM). A DICOM library

Copyright (c) 2006-2016 Mathieu Malaterre

Copyright (c) 1993-2005 CREATIS

(CREATIS = Centre de Recherche et d'Applications en Traitement de l'Image)

All rights reserved.

Redistribution and use in source and binary forms, with or without modification, are permitted provided that the following conditions are met:

- Redistributions of source code must retain the above copyright notice, this list of conditions and the following disclaimer.
- Redistributions in binary form must reproduce the above copyright notice, this list of conditions and the following disclaimer in the documentation and/or other materials provided with the distribution.
- Neither name of Mathieu Malaterre, or CREATIS, nor the names of any contributors (CNRS, INSERM, UCB, Universite Lyon I), may be used to endorse or promote products derived from this software without specific prior written permission.

THIS SOFTWARE IS PROVIDED BY THE COPYRIGHT HOLDERS AND CONTRIBUTORS "AS IS" AND ANY EXPRESS OR IMPLIED WARRANTIES, INCLUDING, BUT NOT LIMITED TO, THE IMPLIED WARRANTIES OF MERCHANTABILITY AND FITNESS FOR A PARTICULAR PURPOSE ARE DISCLAIMED. IN NO EVENT SHALL THE AUTHORS OR CONTRIBUTORS BE LIABLE FOR ANY DIRECT, INDIRECT, INCIDENTAL, SPECIAL, EXEMPLARY, OR CONSEQUENTIAL DAMAGES (INCLUDING, BUT NOT LIMITED TO, PROCUREMENT OF SUBSTITUTE GOODS OR SERVICES; LOSS OF USE, DATA, OR PROFITS; OR BUSINESS INTERRUPTION) HOWEVER CAUSED AND ON ANY THEORY OF LIABILITY, WHETHER IN CONTRACT, STRICT LIABILITY, OR TORT (INCLUDING NEGLIGENCE OR OTHERWISE) ARISING IN ANY WAY OUT OF THE USE OF THIS SOFTWARE, EVEN IF ADVISED OF THE POSSIBILITY OF SUCH DAMAGE.

16.4 ITK

TERMS AND CONDITIONS FOR USE, REPRODUCTION, AND DISTRIBUTION

1. Definitions.

License shall mean the terms and conditions for use, reproduction, and distribution as defined by Sections 1 through 9 of this document.

Licensor shall mean the copyright owner or entity authorized by the copyright owner that is granting the License.

Legal Entity shall mean the union of the acting entity and all other entities that control, are controlled by, or are under common control with that entity. For the purposes of this definition,

control means (i) the power, direct or indirect, to cause the direction or management of such entity, whether by contract or otherwise, or (ii) ownership of fifty percent (50%) or more of the outstanding shares, or (iii) beneficial ownership of such entity.

You (or Your) shall mean an individual or Legal Entity exercising permissions granted by this License.

Source form shall mean the preferred form for making modifications, including but not limited to software source code, documentation, and configuration files.

Object form shall mean any form resulting from mechanical transformation or translation of a Source form, including but not limited to compiled object code, generated documentation, and conversions to other media types.

Work shall mean the work of authorship, whether in Source or Object form, made available under the License, as indicated by a copyright notice that is included in or attached to the work (an example is provided in the Appendix below).

16.4 ITK (cont.)

Derivative Works shall mean any work, whether in Source or Object form, that is based on (or derived from) the Work and for which the editorial revisions, annotations, elaborations, or other modifications represent, as a whole, an original work of authorship. For the purposes of this License, Derivative Works shall not include works that remain separable from, or merely link (or bind by name) to the interfaces of, the Work and Derivative Works thereof.

Contribution shall mean any work of authorship, including the original version of the Work and any modifications or additions to that Work or Derivative Works thereof, that is intentionally submitted to Licensor for inclusion in the Work by the copyright owner or by an individual or Legal Entity authorized to submit on behalf of the copyright owner. For the purposes of this definition, submitted means any form of electronic, verbal, or written communication sent to the Licensor or its representatives, including but not limited to communication on electronic mailing lists, source code control systems, and issue tracking systems that are managed by, or on behalf of, the Licensor for the purpose of discussing and improving the Work, but excluding communication that is conspicuously marked or otherwise in writing by the copyright owner as Not a Contribution.

Contributor shall mean Licensor and any individual or Legal Entity on behalf of whom a Contribution has been received by Licensor and subsequently incorporated within the Work.

2. Grant of Copyright License. Subject to the terms and conditions of this License, each Contributor hereby grants to You a perpetual, worldwide, non-exclusive, no-charge, royalty-free, irrevocable copyright license to reproduce, prepare Derivative Works of, publicly display, publicly perform, sublicense, and distribute the Work and such Derivative Works in Source or Object form.

3. Grant of Patent License. Subject to the terms and conditions of this License, each Contributor hereby grants to You a perpetual, worldwide, non-exclusive, no-charge, royalty-free, irrevocable (except as stated in this section) patent license to make, have made, use, offer to sell, sell, import, and otherwise transfer the Work, where such license applies only to those patent claims licensable by such Contributor that are necessarily infringed by their Contribution(s) alone or by combination of their Contribution(s) with the Work to which such Contribution(s) was submitted. If You institute patent litigation against any entity (including a cross-claim or counterclaim in a lawsuit) alleging that the Work or a Contribution incorporated within the Work constitutes direct contributory patent infringement, then any patent licenses granted to You under this License for that Work shall terminate as of the date such litigation is filed.

4. Redistribution. You may reproduce and distribute copies of the or Derivative Works thereof in any medium, with or without modifications, and in Source or Object form, provided that You meet the following conditions:

(a) You must give any other recipients of the Work or Derivative Works a copy of this License; and

(b) You must cause any modified files to carry prominent notices stating that You changed the files; and

(c) You must retain, in the Source form of any Derivative Works that You distribute, all copyright, patent, trademark, and attribution notices from the Source form of the Work, excluding those notices that do not pertain to any part of the Derivative Works; and

(d) If the Work includes a NOTICE text file as part of its distribution, then any Derivative Works that You distribute must include a readable copy of the attribution notices contained within such NOTICE file, excluding those notices that do not pertain to any part of the Derivative Works, in at least one of the following places: within a NOTICE text file distributed as part of the Derivative Works; within the Source form or documentation, if provided along with the Derivative Works; or, within a display generated by the Derivative Works, if and wherever such third-party notices normally appear. The contents of the NOTICE file are for informational purposes only and do not modify the License. You may add Your own attribution notices within Derivative Works that You distribute, alongside or as an addendum to the NOTICE text from the Work, provided that such additional attribution notices cannot be construed as modifying the License.

You may add Your own copyright statement to Your modifications and may provide additional or different license terms and conditions for use, reproduction, or distribution of Your modifications, or for any such Derivative Works as a whole, provided Your use, reproduction, and distribution of the Work otherwise complies with the conditions stated in this License.

16.4 ITK (cont.)

5. Submission of Contributions. Unless You explicitly state otherwise, any Contribution intentionally submitted for inclusion in the Work by You to the Licensor shall be under the terms and conditions of this License, without any additional terms or conditions. Notwithstanding the above, nothing herein shall supersede or modify the terms of any separate license agreement you may have executed with Licensor regarding such Contributions.

6. Trademarks. This License does not grant permission to use the trade names, trademarks, service marks, or product names of the Licensor, except as required for reasonable and customary use in describing the origin of the Work and reproducing the content of the NOTICE file.

7. Disclaimer of Warranty. Unless required by applicable law or agreed to in writing, Licensor provides the Work (and each Contributor provides its Contributions) on an “AS IS” BASIS, WITHOUT WARRANTIES OR CONDITIONS OF ANY KIND, either express or implied, including, without limitation, any warranties or conditions of TITLE, NON-INFRINGEMENT, MERCHANTABILITY, or FITNESS FOR A PARTICULAR PURPOSE. You are solely responsible for determining the appropriateness of using or redistributing the Work and assume any risks associated with Your exercise of permissions under this License.

8. Limitation of Liability. In no event and under no legal theory, whether in tort (including negligence), contract, or otherwise, unless required by applicable law (such as deliberate and grossly negligent acts) or agreed to in writing, shall any Contributor be liable to You for damages, including any direct, indirect, special, incidental, or consequential damages of any character arising as a result of this License or out of the use or inability to use the Work (including but not limited to damages for loss of goodwill, work stoppage, computer failure or malfunction, or any and all other commercial damages or losses), even if such Contributor has been advised of the possibility of such damages.

9. Accepting Warranty or Additional Liability. While redistributing the Work or Derivative Works thereof, You may choose to offer, and charge a fee for, acceptance of support, warranty, indemnity, or other liability obligations and/or rights consistent with this License. However, in accepting such obligations, You may act only on Your own behalf and on Your sole responsibility, not on behalf of any other Contributor, and only if You agree to indemnify, defend, and hold each Contributor harmless for any liability incurred by, or claims asserted against, such Contributor by reason of your accepting any such warranty or additional liability.”

16.5 Open SSL

Copyright © 1998-2019 The OpenSSL Project. All rights reserved.

Redistribution and use in source and binary forms, with or without modification, are permitted provided that the following conditions are met:

1. Redistributions of source code must retain the above copyright notice, this list of conditions and the following disclaimer.
2. Redistributions in binary form must reproduce the above copyright notice, this list of conditions and the following disclaimer in the documentation and/or other materials provided with the distribution.
3. All advertising materials mentioning features or use of this software must display the following acknowledgment: “This product includes software developed by the OpenSSL Project for use in the OpenSSL Toolkit. (<http://www.openssl.org/>)”
4. The names “OpenSSL Toolkit” and “OpenSSL Project” must not be used to endorse or promote products derived from this software without prior written permission. For written permission, please contact openssl-core@openssl.org.
5. Products derived from this software may not be called “OpenSSL” nor may “OpenSSL” appear in their names without prior written permission of the OpenSSL Project.
6. Redistributions of any form whatsoever must retain the following acknowledgment: “This product includes software developed by the OpenSSL Project for use in the OpenSSL Toolkit (<http://www.openssl.org/>)”

16.5 Open SSL (cont.)

THIS SOFTWARE IS PROVIDED BY THE OpenSSL PROJECT "AS IS" AND ANY EXPRESSED OR IMPLIED WARRANTIES, INCLUDING, BUT NOT LIMITED TO, THE IMPLIED WARRANTIES OF MERCHANTABILITY AND FITNESS FOR A PARTICULAR PURPOSE ARE DISCLAIMED. IN NO EVENT SHALL THE OpenSSL PROJECT OR ITS CONTRIBUTORS BE LIABLE FOR ANY DIRECT, INDIRECT, INCIDENTAL, SPECIAL, EXEMPLARY, OR CONSEQUENTIAL DAMAGES (INCLUDING, BUT NOT LIMITED TO, PROCUREMENT OF SUBSTITUTE GOODS OR SERVICES; LOSS OF USE, DATA, OR PROFITS; OR BUSINESS INTERRUPTION) HOWEVER CAUSED AND ON ANY THEORY OF LIABILITY, WHETHER IN CONTRACT, STRICT LIABILITY, OR TORT (INCLUDING NEGLIGENCE OR OTHERWISE) ARISING IN ANY WAY OUT OF THE USE OF THIS SOFTWARE, EVEN IF ADVISED OF THE POSSIBILITY OF SUCH DAMAGE.

APPENDIX A: Supported Implants and A/P Referencing of the ROSA Knee System



Verify regional availability of implants prior to selection in the Implant Editor (including sizing).

Femoral Implants		
Persona®	NexGen®	Vanguard®
<ul style="list-style-type: none"> - CR Standard - CR Narrow - PS Standard - PS Narrow 	<ul style="list-style-type: none"> - CR Option - CR Porous - CR Precoat - CR Flex Option - CR Flex Porous - CR Flex Precoat - CR Flex Gender Porous - CR Flex Gender Precoat - LPS Option - LPS Porous - LPS Precoat - LPS Flex Option - LPS Flex Porous - LPS Flex Precoat - LPS Flex TiV - LPS Flex Gender - LPS Flex Gender Porous 	<ul style="list-style-type: none"> - CR - PS
Tibial Implants		
Persona	NexGen	Vanguard
<ul style="list-style-type: none"> - Cemented Stemmed Tibia - Trabecular Metal Tibia - Cemented Keel Tibia - OsseoTi® Keel Tibia 	<ul style="list-style-type: none"> - 7° Option Fluted - CR Precoat Pegged - MIS Precoat Stemmed - Option Stemmed - Precoat Stemmed - TM Modular 	<ul style="list-style-type: none"> - Cruciate Finned - I Beam - Regenerex®
Bearing		
Persona	NexGen	Vanguard
<ul style="list-style-type: none"> - Cruciate Retaining (CR) Bearing - Medial Congruent® (MC) Bearing - Ultracongruent (UC) Bearing - Posterior Stabilized (PS) Bearing - Constrained Posterior Stabilized (CPS) Bearing. <p>Refer to implant Surgical Technique for bearing compatibility with implants</p>	Refer to NexGen Surgical Technique	Refer to Vanguard Surgical Technique
Instrumentation's AP Referencing		
Persona	NexGen	Vanguard
<ul style="list-style-type: none"> - Anterior Referencing - Posterior Referencing 	<ul style="list-style-type: none"> - Legacy - PRI (only for Flex implants) 	<ul style="list-style-type: none"> - Posterior Referencing

APPENDIX A: Supported Implants and A/P Referencing of the ROSA Knee System (cont.)

The system has controls to set the femur implant's size, within the following options:

a) For Persona family:

Brand	Size
CR Standard	3, 4, 5, 6, 7, 8, 9, 10, 11, 12
CR Narrow	3, 4, 5, 6, 7, 8, 9, 10, 11
PS Standard	3, 4, 5, 6, 7, 8, 9, 10, 11, 12
PS Narrow	3, 4, 5, 6, 7, 8, 9, 10, 11

b) For NexGen family:

Brand	Size	Brand	Size
CR Option	C, D, E, F, G	LPS Option	A, B, C, D, E, F, G, H
CR Porous	C, D, E, F, G, H	LPS Precoat	B, C, D, E, F, G
CR Precoat	C, D, E, F, G, H	LPS Porous	B, C, D, E, F, G
CR Flex Option	B, C-, C, D-, D, E-, E, F-, F, G-, G	LPS Flex Option	C, D, E, F, G
CR Flex Porous	C-, C, D-, D, E-, E, F-, F, G-, G	LPS Flex Porous	B, C, D, E, F, G
CR Flex Precoat	C-, C, D-, D, E-, E, F-, F, G-, G	LPS Flex Precoat	A, B, C, D, E, F, G, H
CR Flex Gender Porous	C-, C, D-, D, E-, E, F-, F, G-, G	LPS Flex TiV	C, D, E, F, G
CR Flex Gender Precoat	C-, C, D-, D, E-, E, F-, F, G-, G	LPS Flex Gender	C, D, E, F, G
		LPS Flex Gender Porous	C, D, E, F, G

c) For Vanguard family:

Brand	Size
CR	55, 57.5, 60, 62.5, 65, 67.5, 70, 72.5, 75, 80
PS	55, 57.5, 60, 62.5, 65, 67.5, 70, 72.5, 75, 80

The system has controls to set the tibial implant's size, within the following options:

a) For Persona family:

Brand	Size
Cemented Stemmed Tibia	C, D, E, F, G, H, J
Trabecular Metal Tibia	C, D, E, F, G, H, J
Cemented Keel Tibia	C, D, E, F, G, H, J
OsseoTi Keel Tibia	C, D, E, F, G, H, J

APPENDIX A: Supported Implants and A/P Referencing of the ROSA Knee System (cont.)

b) For NexGen family:

Brand	Size
7° Option Fluted	1, 2, 3, 4, 5, 6, 7, 8, 9, 10
CR Precoat Pegged	1, 2, 3, 4, 5, 6, 7, 8, 9, 10
MIS Precoat Stemmed	1, 2, 3, 4, 5, 6, 7, 8, 9, 10
Option Stemmed	3, 4, 5, 6, 7, 8
Precoat Stemmed	1, 2, 3, 4, 5, 6, 7, 8, 9, 10
TM Modular	2, 3, 4, 5, 6, 7, 8

c) For Vanguard family:

Brand	Size
Cruciate Finned	59, 63, 67, 71, 75, 79, 83, 87, 91
I Beam	59, 63, 67, 71, 75, 79, 83, 87, 91
Regenerex	59, 63, 67, 71, 75, 79, 83, 87

The system has controls to set the polyethylene's thickness, within the following options:

Brand	Brand	Size	Thickness (mm)
NexGen	CR	1-2, 3-4, 5-6, 7-10	10, 12, 14, 17, 20
NexGen	LPS	1-2, 3-4, 5-6, 7-10	10, 12, 14, 17, 20, 23
Persona	CR	CD, EF, GH, J	10, 11, 12, 13, 14, 16, 18
Persona	PS	CD, EF, GH, J	10, 11, 12, 13, 14, 16, 18, 20
Vanguard	CR	59, 63/67, 71/75, 79/83, 87/91	10, 11, 12, 13, 14, 16, 18
Vanguard	PS	59, 63/67, 71/75, 79/83, 87/91	10, 11, 12, 13, 14, 16, 18, 20

The polyethylene's family is the same as the implant family.

The polyethylene's brand is the same as the femur implant's brand.

The polyethylene's size is the same as the tibial implant's size.

APPENDIX B: Implant Compatibility Between Femoral and Tibial Component Brands

a) For Persona family: All implant brands are compatible

b) For NexGen family:

Tibia: NexGen Brand	Femur: NexGen Brand			
	CR	CR Flex	LPS	LPS Flex
7° Option Fluted	X	X	X	X
CR Precoat Pegged	X			
MIS Modular Precoat Stemmed	X	X	X	X
Option Stemmed	X	X	X	X
Precoat Stemmed	X	X	X	X
TM Modular	X	X	X	X

c) For Vanguard family: All implant brands are compatible

APPENDIX C: Implant Compatibility Between Femoral and Tibial Component Sizes

a) For Persona CR femoral implants:

		Persona CR Femoral Size									
		3	4	5	6	7	8	9	10	11	12
Persona Tibial Size	C	X	X	X	X	X	X	X			
	D	X	X	X	X	X	X	X			
	E	X	X	X	X	X	X	X	X	X	
	F	X	X	X	X	X	X	X	X	X	
	G					X	X	X	X	X	X
	H					X	X	X	X	X	X
	J							X	X	X	X

APPENDIX C: Implant Compatibility Between Femoral and Tibial Component Sizes (cont.)

Refer to implant-specific Surgical Technique for bearing compatibility.

b) For Persona PS femoral implants:

		Persona PS Femoral Size									
		3	4	5	6	7	8	9	10	11	12
Persona Tibial Size	C	X	X	X	X	X	X	X			
	D	X	X	X	X	X	X	X			
	E	X	X	X	X	X	X	X	X	X	
	F	X	X	X	X	X	X	X	X	X	
	G				X	X	X	X	X	X	X
	H				X	X	X	X	X	X	X
	J								X	X	X

c) For NexGen CR femoral implants:

		NexGen CR Femoral Size							
		A	B	C-/C	D-/D	E-/E	F-/F	G-/G	H-/H
NexGen Tibial Size	1-2	X	X	X	X	X	X	X	X
	3-4	X	X	X	X	X	X	X	X
	5-6	X	X	X	X	X	X	X	X
	7-10			X	X	X	X	X	X

d) For NexGen LPS femoral implants:

		NexGen LPS Femoral Size							
		A	B	C	D	E	F	G	H
NexGen Tibial Size	1-2	X	X	X	X				
	3-4	X	X	X	X	X	X		
	5-6			X	X	X	X	X	X
	7-10					X	X	X	X

e) For Vanguard implants: All sizes are compatible.

Please visit ZimmerBiomet.com for additional information.

Black Box Warning for Persona IQ

WARNING - The kinematic data from this device have not been demonstrated to have clinical benefit. It is not intended to be utilized for clinical decision-making, and no data have been evaluated by FDA regarding clinical benefits.

De Mayo Knee Positioner® is a trademark of Innovative Medical Products, Inc.

All content herein is protected by copyright, trademarks and other intellectual property rights, as applicable, owned by or licensed to Zimmer Biomet or its affiliates unless otherwise indicated, and must not be redistributed, duplicated or disclosed, in whole or in part, without the express written consent of Zimmer Biomet.

This material is intended for health care professionals. Distribution to any other recipient is prohibited.

For additional indications, contraindications, warnings, precautions, potential adverse effects and patient counseling information, see the package insert or contact your local representative; visit www.zimmerbiomet.com for additional product information.

Check for country product clearance and reference product specific instructions for use. Persona IQ, Persona Porous Plasma Spray (PPS) femur, Persona 0° Cemented Keel Tibia Baseplate, Persona 0° OsseoTi™ Spiked Keel Tibia Baseplate are only available in the United States. Not for distribution in France. MRI image-based planning tools are not available in Europe and the United Kingdom. Consult your sales representative if needed.

Zimmer Biomet does not practice medicine. This technique was developed in conjunction with health care professionals. This document is intended for surgeons and is not intended for laypersons. Each surgeon should exercise his or her own independent judgment in the diagnosis and treatment of an individual patient, and this information does not purport to replace the comprehensive training surgeons have received.

As with all surgical procedures, the technique used in each case will depend on the surgeon's medical judgment as the best treatment for each patient. Results will vary based on health, weight, activity and other variables. Not all patients are candidates for this product and/or procedure.

Caution: Federal (USA) law restricts this device to sale by or on the order of a surgeon. Rx only.

©2021, 2022, 2023, 2024 Zimmer Biomet



2300.11-GLBL-en-Issue Date-2024-01

 **Legal Manufacturer**
Zimmer CAS
75 Queen Street Suite 3300
Montreal (Quebec) H3C 2N6
Canada
Tel +1-866-3D-ORTHO
or 514-396-5422

zimmerbiomet.com

 **canturio™ te Manufactured for:**
Canary Medical USA LLC
2710 Loker Ave. West, Suite 350
Carlsbad, California 92010
Customer Service: 1-833-722-6279
or 1-833-7CANARY

canarymedical.com

 **canturio™ te Exclusively Distributed by:**
Zimmer, Inc.
1800 West Center St.
Warsaw, Indiana 46581-0587 USA

 IFUs, Patents &
Symbol Glossary
<http://labeling.zimmerbiomet.com>