

Persona® Partial Knee System

Surgical Technique



Table of Contents

Introduction	1
Cross-System Compatibility	1
Surgical Technique	2
Positioning the Limb	2
Incision	2
Osteophyte Excision	3
Proximal Tibial Resection	4
Verifying the Tibial Cut	11
Verifying Limb Alignment	12
Distal Femoral Condyle Resection	13
Confirming the Flexion and Extension Gaps.....	14
Femoral Sizing.....	15
Femoral Posterior Cut, Chamfer Cut, and Peg Hole Preparation.....	17
Size the Tibia	20
Finish the Tibia	22
Perform Trial Reduction	25
Implanting Final Components.....	27
Bearing Assembly	30
Closure.....	30
Ordering Information	32
Appendix I	44

Introduction

The Persona Partial Knee System is a unicondylar knee replacement system that is designed with an instrument platform that provides surgeons with tools to help with alignment and positioning using a simple, straight-forward surgical technique. The Persona Partial Knee System consists of femoral, tibial tray and bearing components.

System Compatibility

Within the Persona Partial Knee System all femur sizes are compatible with all tibia/bearing sizes. Each bearing component is uniquely compatible to the corresponding tibial component size and side (e.g. an E left medial bearing component fits ONLY with the E left medial tibial component. A right medial bearing component IS NOT compatible with a left medial tibial component)

Cross-System Compatibility

The Zimmer® Gender Solutions® Patello-Femoral Joint (PFJ) may be used with the Persona Partial Knee System. The Allegretto® Unicompartmental Resurfacing femoral component is compatible with the Persona Partial Knee tibial tray and bearing components.*

*The Allegretto Unicompartmental Resurfacing femoral component is not available in the United States and Canada.





Figure 1

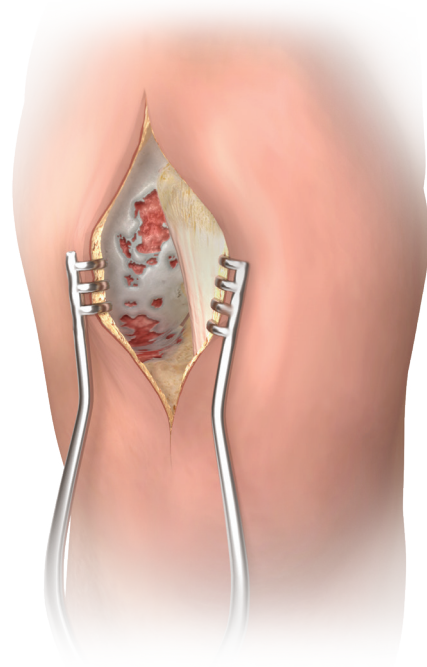

Figure 2

Positioning the Limb

Once the patient is prepped and draped on the operating table, in a supine position, the knee and ipsilateral hip should be freely mobile (Figure 1).

Incision

The incision can be made with the leg in flexion or extension. The incision must allow for good exposure. Make a straight skin incision from the medial margin of the patella to a point approximately 3 cm distal to the joint line (Figure 2); a good ratio is usually an incision that is $\frac{2}{3}$ above and $\frac{1}{3}$ below the joint line. Deepen the incision through the subcutaneous tissues to the joint capsule. The deep exposure can be medial parapatellar, midvastus or subvastus depending on the surgeon's preference and experience. The deep arthrotomy should pass around the patella and along the medial side of the patellar tendon.

Expose the front of the tibia in the lower part of the wound from the tibial tubercle to the antero-medial rim of the plateau. Excise as much of the medial meniscus as possible. Do not 'release' any of the fibers of the medial collateral ligament.

Excise part of the retropatellar fat pad and insert retractors to expose the medial compartment and intercondylar notch; the lateral and patellofemoral compartments should also be inspected prior to proceeding. Insufficiency of the collateral, anterior or posterior cruciate ligaments, which would preclude stability of the device, is a contraindication. If this is found, the operation should be abandoned in favor of a total knee replacement.



Figure 3

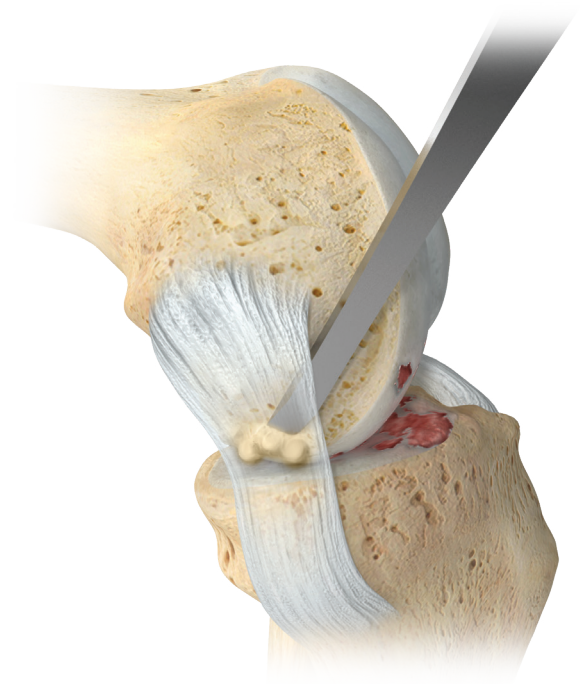

Figure 4

Osteophyte Excision

All osteophytes must be removed from the medial margin of the medial femoral condyle and from both margins of the intercondylar notch, around the ACL (Figure 3). Varying the amount of flexion and extension of the knee will allow the surgeon to visualize the various osteophytes facilitating removal. Osteophytes on the tibial plateau in front of the insertion of the ACL and in the intercondylar notch must be removed, this is one way to correct the presence of a fixed flexion deformity. If there are large osteophytes around the patella they can also be removed. Osteophytes beneath the medial collateral ligament (Figure 4) and from the posterolateral margin of the medial condyle in the intercondylar notch should be removed. This creates room to insert the saw blade into the intercondylar notch during the next steps.

- ☰ **Technique Tip:** It is important for osteophytes to be removed before balancing your flexion and extension space.
- ☰ **Technique Tip:** A 6 mm chisel is helpful in removing osteophytes.

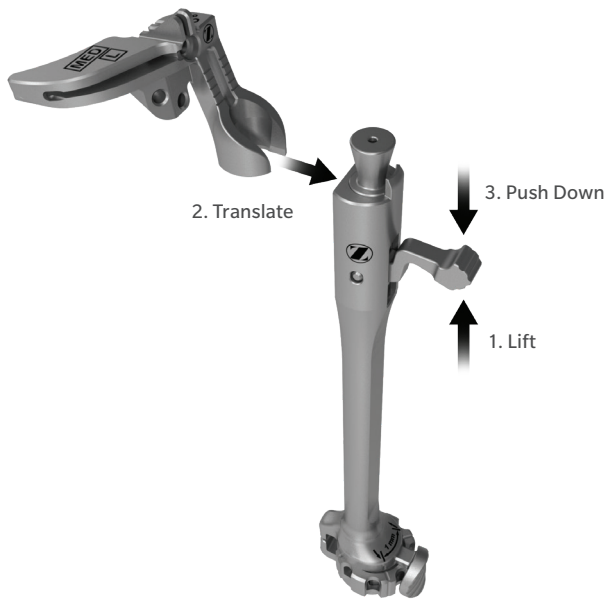

Figure 5

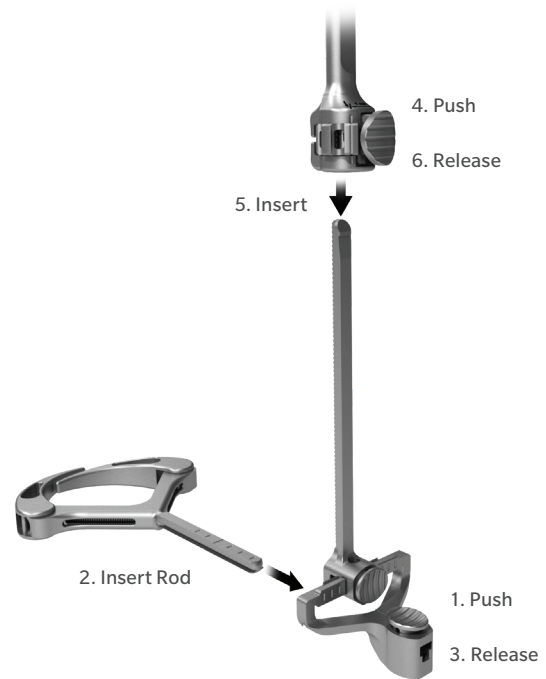

Figure 6

Proximal Tibial Resection

In this technique, there are two instrumentation options for making the proximal tibial resection, Option 1 and Option 2. The main differences in these options are:

Option 1 provides a captured vertical cut with a corner pin that acts as a saw stop. The primary guides and recutters are stainless steel.

Option 2 Provides an uncaptured vertical cut, with the vertical cut landing on top of the cut guide as a reference. The primary cutters and recutters are gold nitride-coated.

- The pin locations differ slightly between the guides, therefore the primary guides and recutters cannot be interchanged between options.

The technique for option 2 is located in Appendix I on page 44 of this technique.

Option 1: Proximal Tibial Resection

Assemble the extramedullary (EM) alignment guide. Attach the tibial cut guide to the EM alignment guide by lifting the lever of the EM proximal tube translating the tibial cut guide onto the top of the EM proximal tube, under the locking cone. Secure by pushing the lever on the EM proximal tube down to lock the tibial cut guide in place (Figure 5).

Depress and hold the button on the EM distal rod and insert the threaded rod on the EM ankle clamp into the EM distal rod and release the button. Depress and hold the button on the distal end of the EM proximal tube and insert the EM distal rod into the EM proximal tube and release the button (Figure 6).

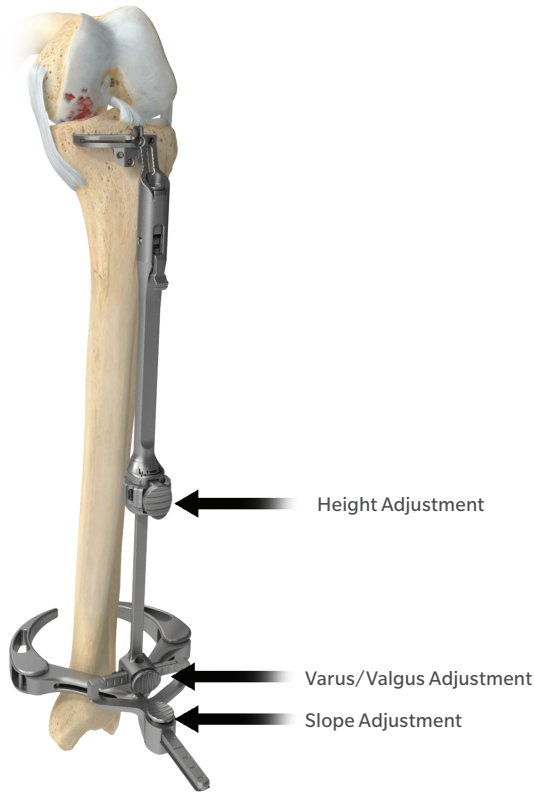

Figure 7

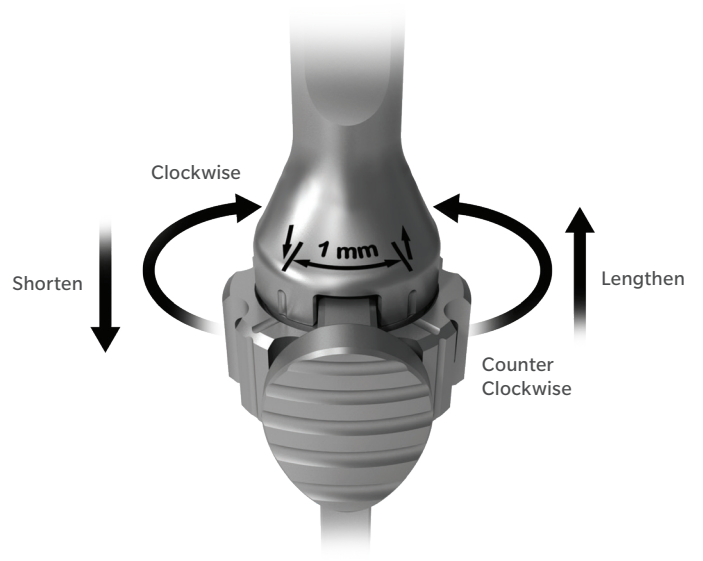

Figure 8

Proximal Tibial Resection (cont.)

The buttons shown in Figure 7 are used to adjust the tibial cut guide in the following manner: varus/valgus angle, posterior slope, and the height or depth of resection. The height adjustment button can be depressed for macro-adjustment or the dial can be rotated for micro-adjustment.

One full rotation of the dial equals 4 mm of height adjustment and $\frac{1}{4}$ turn equals 1 mm of height adjustment (Figure 8). Rotating the height adjustment dial clockwise lowers the EM alignment guide for resecting more tibia. Rotating the dial counterclockwise raises the EM alignment guide for resecting less tibia.

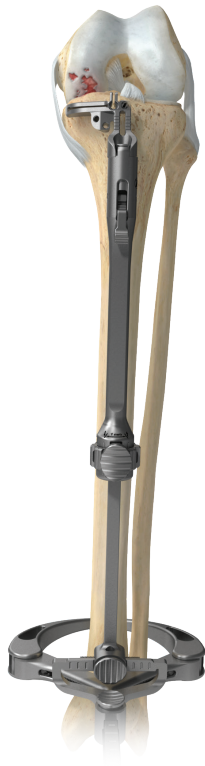

Figure 9



Figure 10

Proximal Tibial Resection (cont.)

Secure the distal portion of the assembly by placing the spring arms of the EM ankle clamp around the ankle proximal to the malleoli. Use the posterior slope adjustment and varus/valgus adjustment to set the EM alignment guide parallel with the long axis of the tibia in both frontal (Figure 9) and sagittal (Figure 10) planes.

This will set the tibial resection perpendicular to the mechanical axis with 5 degrees of posterior slope. The tibial cut guide has 5 degrees of posterior slope built in. Correct rotation can be achieved from lining up the guide on the tibial tubercle proximally (junction of middle and medial third) and the center of the talus distally (medial to the midpoint of the ankle).

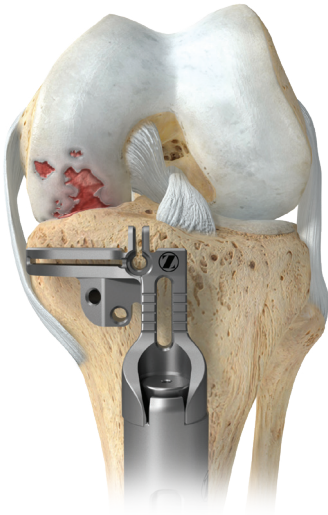

Figure 11

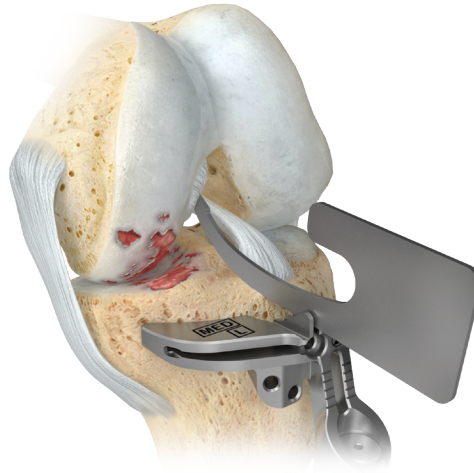

Figure 12

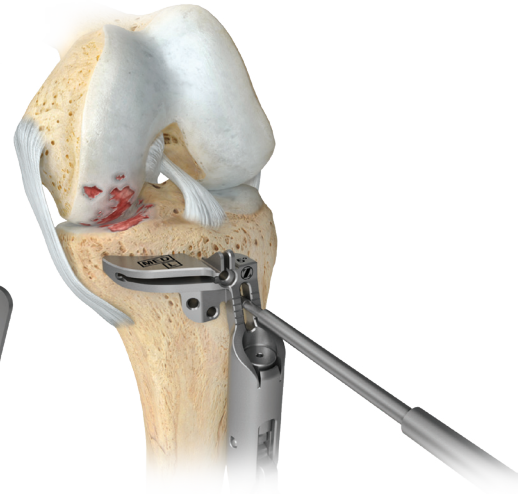

Figure 13

Proximal Tibial Resection (cont.)

Use the height adjustment to set the tibial cut guide at the approximate resection level (Figure 11). **Set the position of the sagittal cut slot so that the resection plane will be adjacent to the medial fibers of the ACL attachment and pass just medial to the apex of the medial tibial spine.** An angel wing may be used through the slot to help visualize the resection plane and rotation (Figure 12).

Insert a headless trochar pin through the center of the 12 mm vertical slot to set the position of the sagittal cut slot (Figure 13). The goal is to obtain optimal coverage of the tibial plateau, so the M/L position should be as far lateral as possible without impinging on the insertion of the ACL.

- ⊖ **Technique Tip:** It is important to insert the headless trochar pin through the center of the 12 mm vertical slot when setting the position of the sagittal cut slot. This allows adjustment both up and down to set the optimal depth of the tibial cut.
- ⊖ **Technique Tip:** When using any headless trochar pin, it is important to leave 10 mm or more of the pin exposed. This will allow for ease of removal when using the pin puller.

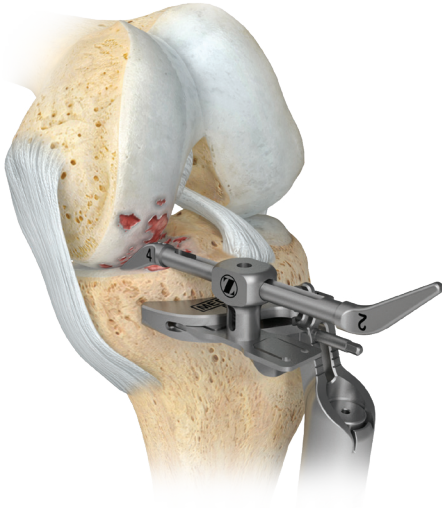

Figure 14

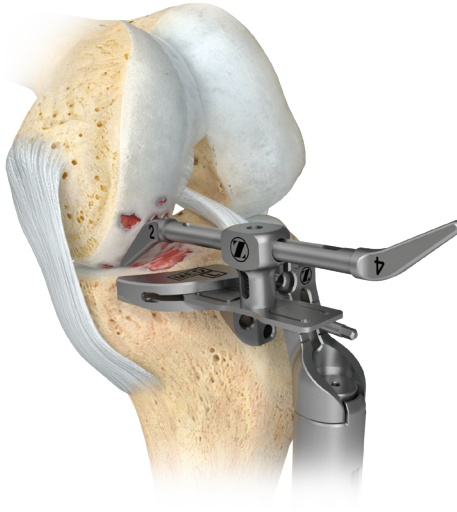

Figure 15



Figure 16

Proximal Tibial Resection (cont.)

Insert the foot of the tibial stylus into the cutting slot of the tibial cut guide (Figure 14). Using the 4 mm tip of the stylus, adjust the final height of the tibial cut guide by rotating the micro-adjustment of the EM proximal tube clockwise (downward adjustment) or counter clockwise (upward adjustment) to contact the tibial stylus tip to the lowest point of the worn antero-medial tibial plateau (Figure 14).

A thinner cut may be desired if there is severe wear of the tibia. In this case, the 2 mm tip of the stylus can be used (Figure 15). An angel wing can be placed through the cut slot on the tibial cut guide to confirm the desired level and slope of the proximal tibial resection (Figure 16). If more or less slope is required this can be adjusted by using the slope adjustment buttons of the EM alignment guide.

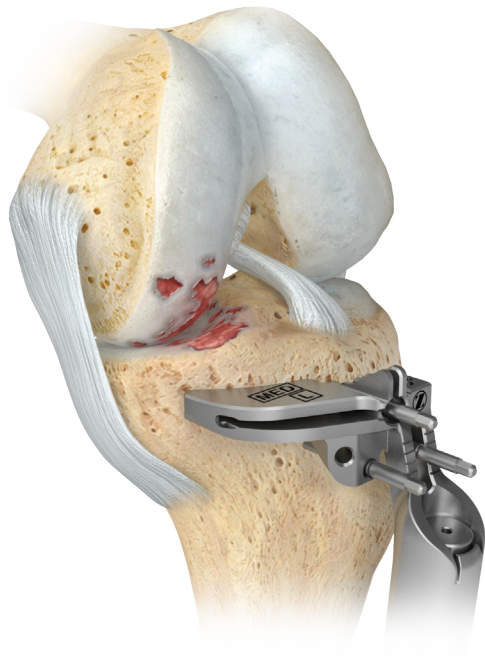

Figure 17

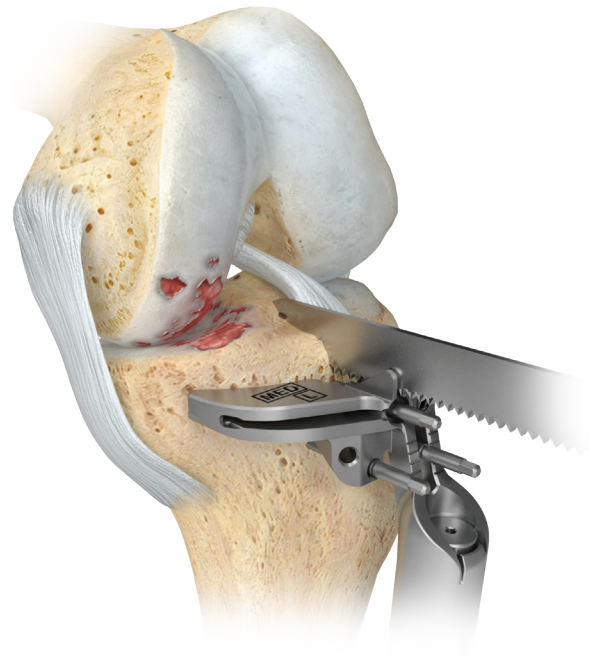

Figure 18

Proximal Tibial Resection (cont.)

Secure the tibial cut guide by inserting a headless trocar pin through the corner hole of the tibial cut guide followed by inserting another headless trocar pin through the parallel hole of the tibial cut guide (Figure 17).

ⓘ **Technique Tip:** When using any headless trochar pin, it is important to leave 10 mm or more of the pin exposed. This will allow for ease of removal when using the pin puller.

The headless trocar pin through the corner hole will act as a saw stop for the sagittal and horizontal resections. Use a single-sided reciprocating saw blade through the vertical slot in the tibial cut guide to make the sagittal cut. The saw cut should be just medial to the apex of the medial tibial spine and pass medial to or just through the medial edge of the ACL insertion (Figure 18).

ⓘ **Technique Tip:** If the saw blade is lying too medial or lateral when lined up in the vertical slot it can be placed adjacent but parallel to the slot utilizing the grooves incorporated in the tibial cut guide. In this case surgeons need to be aware that the saw blade will not come into contact with the trochar pin and care must be taken to keep the saw parallel to the pin in the corner hole and stop cutting adjacent to it.

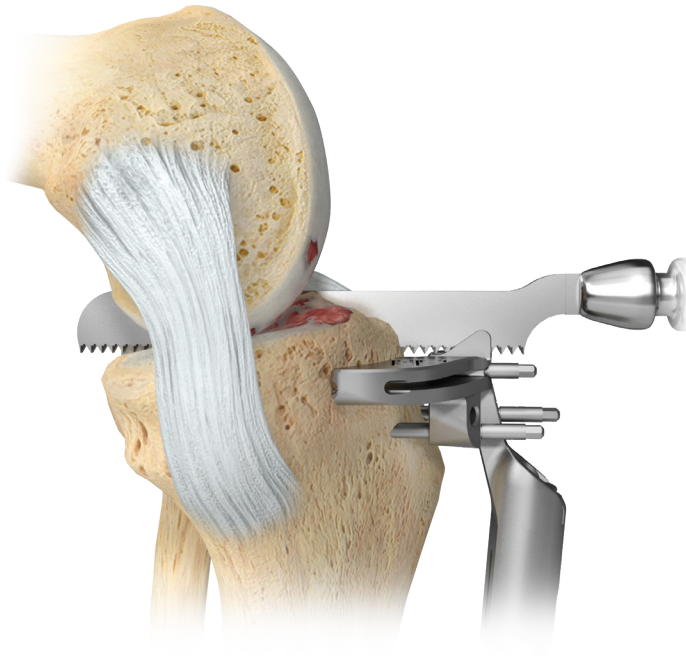

Figure 19

Proximal Tibial Resection (cont.)

The sagittal cut can be made now. Make sure the saw reaches the back of the tibial plateau and a little beyond advancing the saw vertically down until it rests on pin through the corner hole. Do not lift the saw handle as this will lead to a vertical cut below the horizontal cut surface and increase the risk of post-operative tibial plateau fracture (Figure 19).

🔑 **Technique Tip:** Avoid damaging the posterior popliteal area by using a blunt tip reciprocating blade.

Before making the horizontal cut insert a medial collateral ligament (MCL) retractor. Ensure this retractor lies between the saw and the MCL, protecting the deep fibers of the ligament. Use a 1.27 mm (0.050 – inch) x 12.5/13 mm oscillating blade through the cut slot in the tibial cut guide to make the horizontal tibial cut. Ensure the saw blade is guided along the MCL retractor to cut the medial cortex completely without damaging the MCL. When the cut is complete the plateau usually can be seen to move freely.

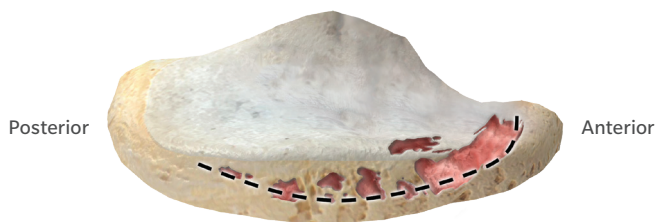

Figure 20

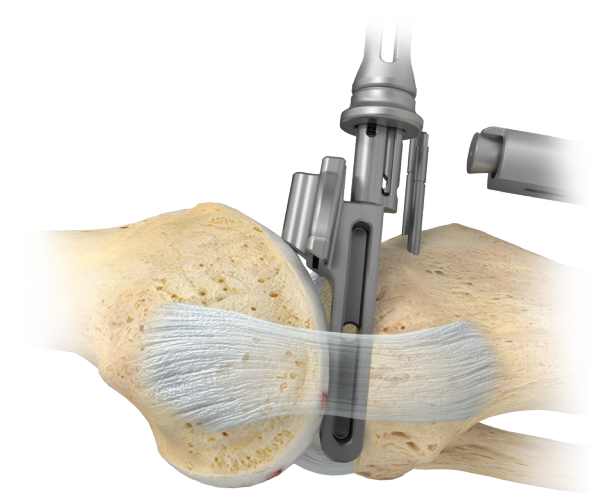

Figure 21



Figure 22

Verifying the Tibial Cut

Place an osteotome into the horizontal osteotomy and lift it upwards to remove the resected tibial plateau. Flexing the knee 10-15 degrees may assist with removal of the resected tibial plateau. Soft tissue attachments posteromedial may need to be released with a bovie or a knife. Examination of the excised tibial plateau should show the features typical of anteromedial arthritis (Figure 20), full thickness cartilage loss anteriorly and relative preservation of the cartilage posteriorly. If this pattern is not observed re-assess the status of the ACL. The excised plateau can be examined to check if the desired posterior slope has been achieved.

Remove the tibial cut guide from the EM alignment guide leaving the EM alignment guide in place along with headless trocar pins used to secure the tibial cut guide (the pin in the corner hole will be removed with the excised plateau). Attach the PK (Partial Knee) handle to the 9 mm spacer block to facilitate insertion of the spacer block into the joint space. With the knee flexed to 5 – 10 degrees insert the 9 mm spacer block to ensure the tibial resection is sufficient (Figure 21).

The thickness is correct when the 9 mm spacer block can slide easily in and out. If the 9 mm spacer block is too loose, use a thicker spacer block to fill the extension gap.

If the 9 mm spacer block or handle has to be firmly gripped to slide in and out, this is too tight, additional tibial resection is required. To re-cut the proximal tibia, apply the 2 mm recutter over the headless trocar pins and reattach the EM alignment guide (Figure 22). A headless trocar pin can be inserted into the oblique hole if additional fixation is desired. Use an oscillating saw with a 1.27 mm (0.050-inch) x 12.5/13 mm blade to cut the tibia through the horizontal slot in the 2 mm recutter taking care to avoid undercutting the tibial eminence as the corner pin is not present. Remove the 2 mm recutter and re-check the extension gap with the 9 mm spacer block to ensure the tibial resection is now sufficient.

☹ **Technique Tip:** It is recommended to use a 9 mm spacer block instead of an 8 mm spacer block as a 9 mm spacer allows the surgeon intraoperative flexibility of +/- 1 mm.



Figure 23



Figure 24

Verifying Limb Alignment

Two options are available for verifying limb alignment.

Option #1: With the spacer block inserted into the extension space, assemble the alignment rods. Place the proximal end of the alignment rod at the center of the femoral head and distally at the center of the ankle. Relative to the midline of the knee, the rod will fall medial to the midline of the knee indicating the knee is not over corrected (Figure 23).

Option #2: Attach the alignment tower to the spacer block and insert the alignment rod through the alignment tower confirming the knee is not over corrected (Figure 24).

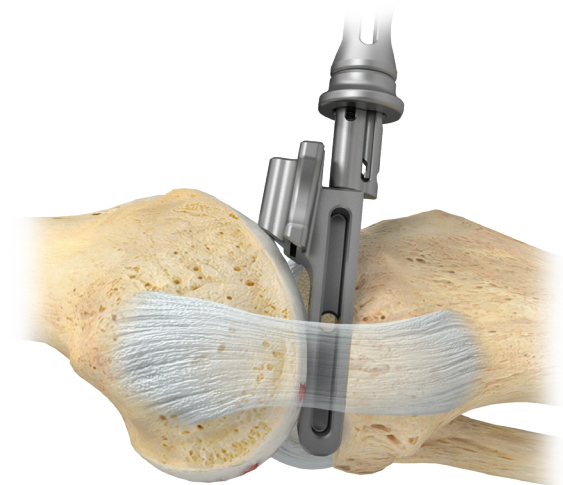

Figure 25

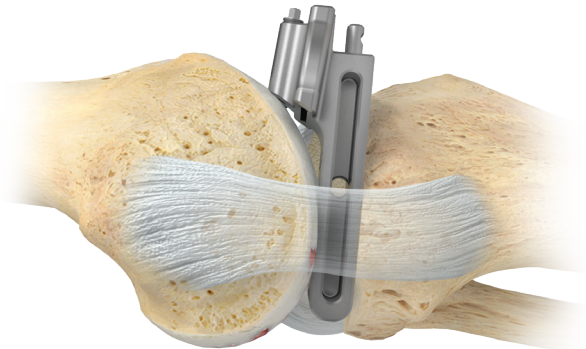

Figure 26

Distal Femoral Condyle Resection

For ease of insertion attach the PK handle to the anterior attachment of the spacer block (Figure 25). With the knee in extension, insert the 9 mm spacer block, or the thickness used earlier to confirm the tibial resection, until the distal femoral cut slot contacts the anterior aspect of the femur or posterior soft tissues prevent further insertion of the spacer block (Figure 25). It is important to confirm the spacer block is fully inserted, sitting flat on the resected tibia, and contacting the distal femur. Remove any anterior osteophytes if necessary. Confirm the knee is not hyperextended. With the distal femoral cut slot centered on the femoral condyle use a 48 mm headed screw to secure the spacer block in place (Figure 26).

Make the distal femoral cut using a 1.27 mm (0.050 in) x 12.5/13 mm oscillating saw blade. It is important to avoid making the distal femoral cut in hyperextension. To avoid damaging the posterior popliteal area, do not extend the saw blade posteriorly past the distal femur while the leg is held in extension. Insert a retractor to protect the MCL. Remove the 48 mm headed screw and spacer block.



Figure 27

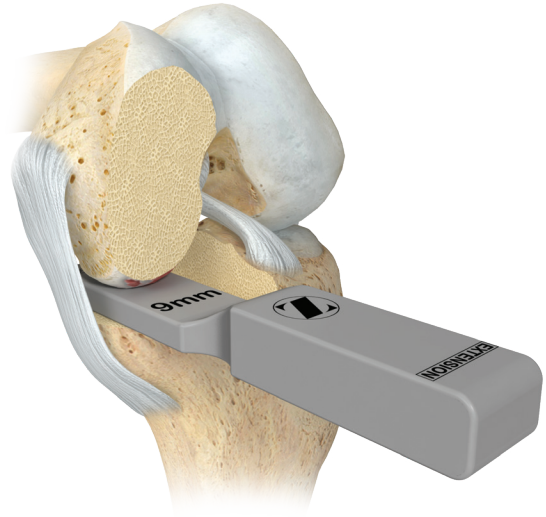

Figure 28

Confirming the Flexion and Extension Gaps

Select the flexion/extension gap checker thickness that matched the spacer block thickness used in the previous step. Insert the thick end of the flexion/extension gap checker (labelled EXTENSION) in extension. It is important to measure the extension gap in 5 - 10 degrees of flexion, confirming the knee will reach full extension. In full extension, the posterior capsule is tight, and its influence gives a false under-measurement. The thickness of the EXTENSION end duplicates the combined thickness of the corresponding tibial component bearing construct and femoral component in extension giving the feel of the implanted components (Figure 27). Confirmation of the correct thickness is obtained by confirming that the next thickest flexion/extension gap checker is difficult to insert and the next thinnest flexion/extension gap checker is loose while inserting. It is important to ensure a slight under correction of the limb alignment and have appropriate ligamentous tension restored (at least 2 mm of laxity) in extension.

With the knee in about 100 degrees of flexion carefully measure the flexion gap with the thin end (labelled FLEXION) of the same thickness flexion/extension gap checker previously used when checking the extension gap (Figure 28). The thin end of each flexion/extension gap checker simulates the feel of the implanted components in flexion. The thickness is correct when the flexion/extension gap checker will easily slide in and out. Confirmation of the correct thickness is obtained by confirming that the next thickest flexion/extension gap checker is difficult to insert and the next thinnest flexion/extension gap checker is loose. It is important to ensure appropriate ligamentous tension is restored (≥ 2 mm of laxity) in flexion.

☹ **Technique Tip:** The thin end (labeled FLEXION) of any flexion / extension gap checker is 2 mm thinner than the number listed (example: 9 mm flexion / extension gap checker is really 7 mm on the thin end). See page 16 for rationale.

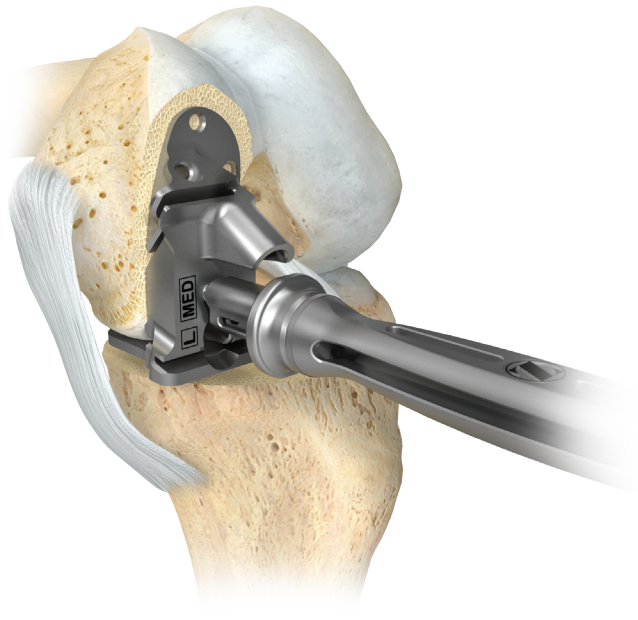

Figure 29

Confirming the Flexion and Extension Gaps (cont.)

- The thin end of each spacer is simulating the feel of the implanted components in flexion.
- When making the posterior femoral resection a +2 mm resection is made to anteriorize the femoral component 2 mm and open up the flexion space. This accounts for the intact cartilage on the posterior femoral condyle.
- It is important to ensure appropriate ligamentous tension is restored (≥ 2 mm of laxity) in flexion.
- If the feel of extension gap is appropriate but the flexion gap is too tight utilize the bone rasp or saw to remove 1 – 2 mm of posterior femoral cartilage prior to finishing the femur.

Femoral Sizing

For ease of insertion attach the PK handle to the anterior attachment on the femoral finishing guide (Figure 29). Use the femoral finishing guide to establish the appropriate femoral size. The profile of each femoral finishing guide matches the location and profile of the corresponding femoral component anteriorly and distally. Attach the PK handle to the femoral finishing guide. With the knee in about 100 degrees of flexion place the guide on the resected distal surface and the retained posterior condyle (Figure 29). Be cautious of any soft tissue or retained osteophytes that might keep the femoral finishing guide from sitting flush against the end of the distal femur.



Figure 30

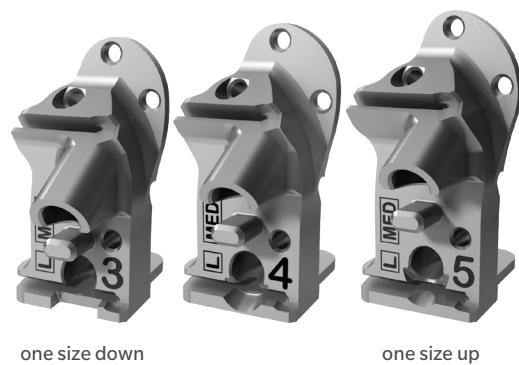

Figure 31

Femoral Sizing (cont.)

When properly sized, there should be a rim of at least 2 mm exposed bone anterior and medial to the femoral finishing guide once the osteophytes have been removed. The medial/lateral position of the femoral finishing guide is also established at this point. The femoral finishing guide should be lateralized as far as possible without impinging into the intercondylar notch (Figure 30). This will increase the likelihood that the tibial component will properly track with the femur in extension and prevent patellofemoral impingement. Proper position is confirmed by ensuring there is no medial or lateral overhang.

If the femoral condyle appears to be between two sizes, choose the smaller size. This prevents overhang, which can lead to patellar impingement (Figure 31).

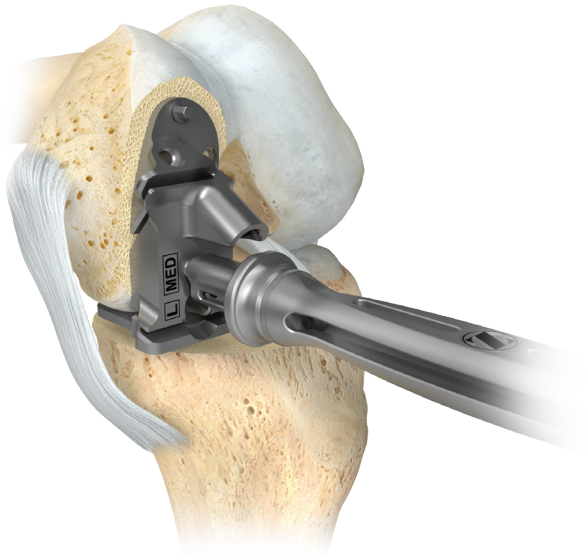

Figure 32



Figure 33

Femoral Posterior Cut, Chamfer Cut, and Peg Hole Preparation

With the proper size femoral finishing guide in position, fix the guide by inserting a 48 mm headed screw into the top pin hole (Figure 32). Be sure to rotate the guide on the screw until the posterior edge of the guide is parallel to the proximal tibial cut surface. Insertion of the thin side (labelled FLEXION) of the flexion/extension gap checker underneath the femoral finishing guide will help to ensure that the surfaces are parallel. If used, the flexion/extension gap checker should be inserted prior to securing the guide with a screw to ensure sizing did not change. It is essential that there is exposed bone on both medial and lateral sides of the femoral finishing guide to ensure that the femoral finishing guide does not overhang.

At this point insert a 48 mm or 33 mm headed screw into the angled anterior pin hole (Figure 33). Consider the size of the bone when selecting the screw length to avoid perforating the posterior cortex. An additional screw can be used, if necessary, to adequately secure the guide to the bone. If a screw is used in the hole nearest the size marking, it must be removed prior to performing the posterior chamfer cut.

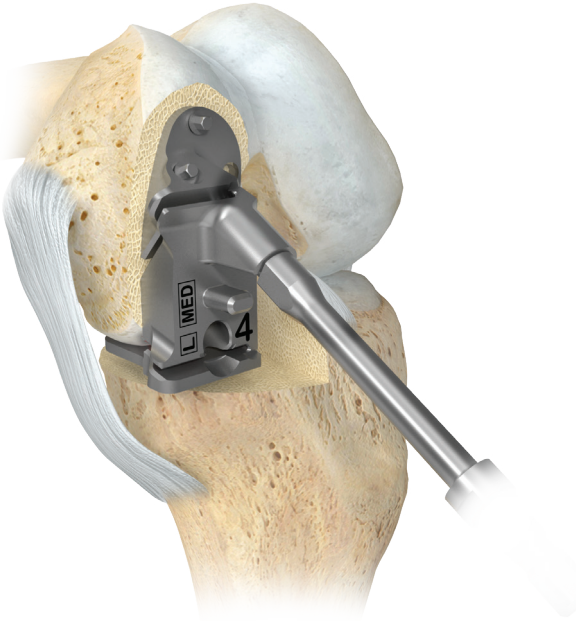

Figure 34

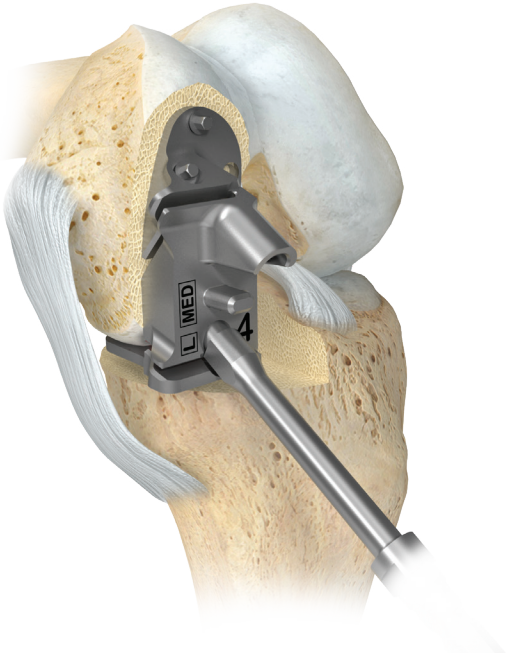

Figure 35

Femoral Posterior Cut, Chamfer Cut, and Peg Hole Preparation (cont.)

Once the femoral finishing guide is determined to be properly oriented and secured, insert the femoral drill with stop into the anterior hole until the stop contacts the femoral finishing guide to drill for the anterior femoral peg (Figure 34).

Next, insert the femoral drill with stop into the posterior hole until the stop contacts the femoral finishing guide to drill for the posterior femoral peg (Figure 35).

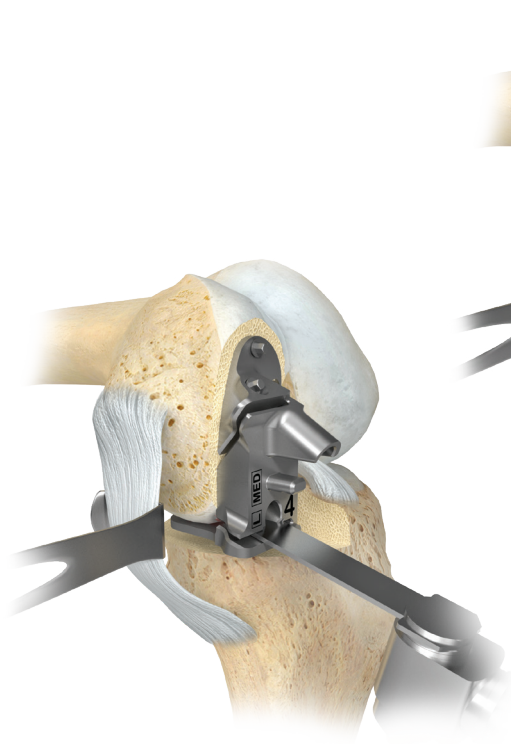

Figure 36

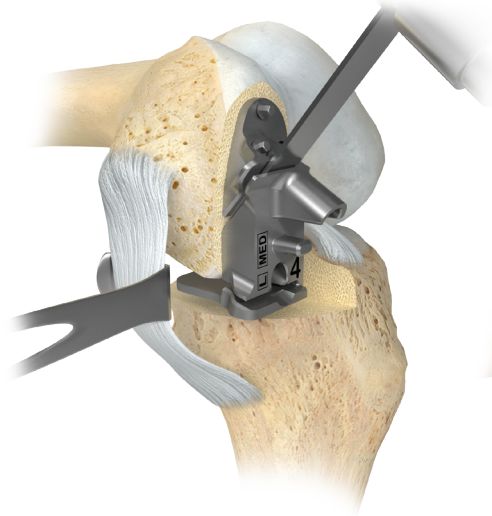

Figure 37

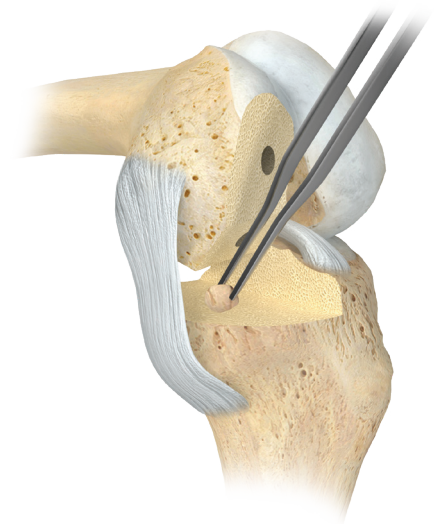

Figure 38

Femoral Posterior Cut, Chamfer Cut, and Peg Hole Preparation (cont.)

Insert a retractor to protect the MCL. Using a 1.27 mm (0.050 in) x 12.5/13 mm oscillating saw, cut the posterior femoral condyle followed by cutting the posterior femoral chamfer through the cut slot (Figures 36 and 37). Take care to avoid damage to the medial collateral and anterior cruciate ligament. Remove the headed screws and the femoral finishing guide checking to make sure all cut surfaces are flat.

Resect any remaining meniscus and remove any osteophytes, especially those interfering with the collateral ligament (Figure 38). Any superior posterior femoral osteophytes should be removed from the medial femoral condyle with a straight or curved osteotome to avoid impingement in deep flexion.

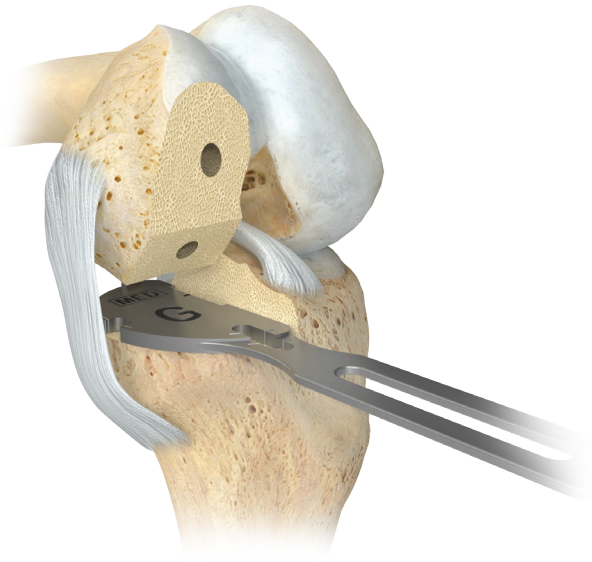

Figure 39



Figure 40

Size the Tibia

Insert the appropriate tibial sizer that best covers the resected proximal tibia in both the A/P and the M/L dimensions (Figure 39).

To ensure the correct size, position the tibial sizer with its posterior margin flush with the posterior tibial cortex. This is facilitated by positioning the tibial sizer laterally against the vertical cut and using the hook (Figure 40) of the tibial sizer over the posterior cortex of the tibia.

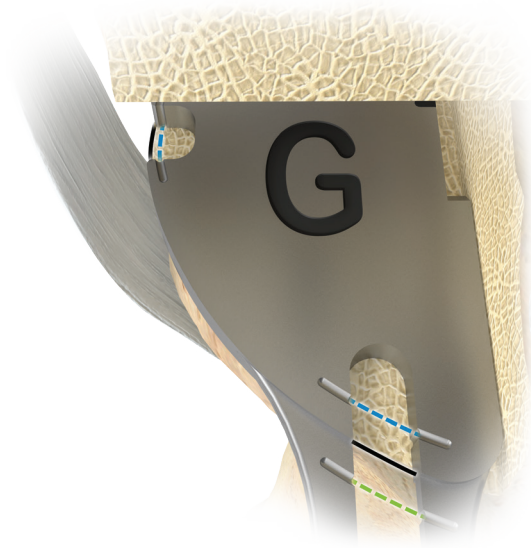

Figure 41

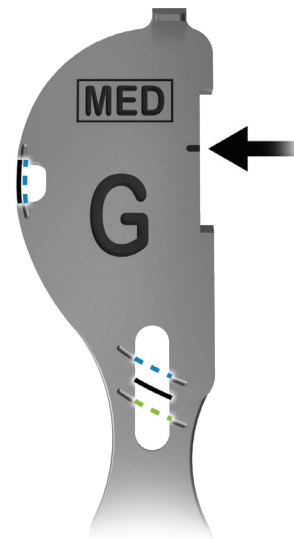

Figure 42

Size the Tibia (cont.)

The tibial sizer should be flush with the medial cortex. Visibility windows are provided at the anterior and medial borders, with engravings that represent the profile of neighboring sizes (Figure 41). These can be used to gauge whether a neighboring size should be used. If the size being evaluated overhangs, confirm that the vertical tibial resection is as far lateral as possible; or use a smaller tibial size. Medial overhang may cause pain and should be avoided.

The location of the keel on the tibial component may be marked through the slot on the medial edge of the tibial sizer (Figure 42).

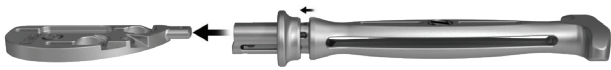

Figure 43

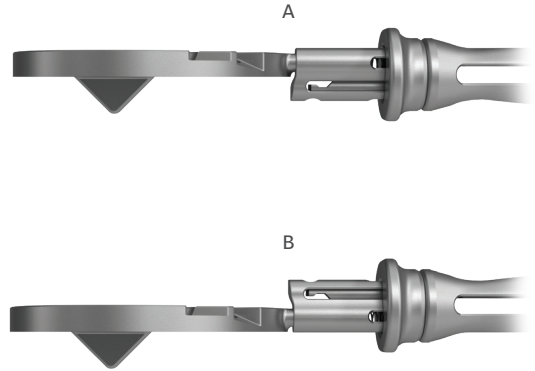

Figure 44

Finish the Tibia

For ease of insertion attach the PK handle to the anterior attachment on the tibial trial (Figure 43).

The PK handle can attach to the tibial trial in 2 orientations (Figure 44). It is recommended to attach the PK handle with the anterior stop distal to facilitate placement of the tibial trial (A). If posteriorization of the tibial trial is desired, the PK handle can be attached with the anterior stop proximal (B).

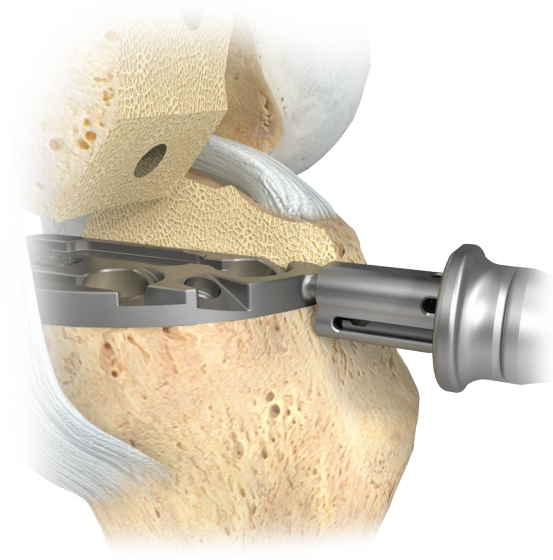

Figure 45

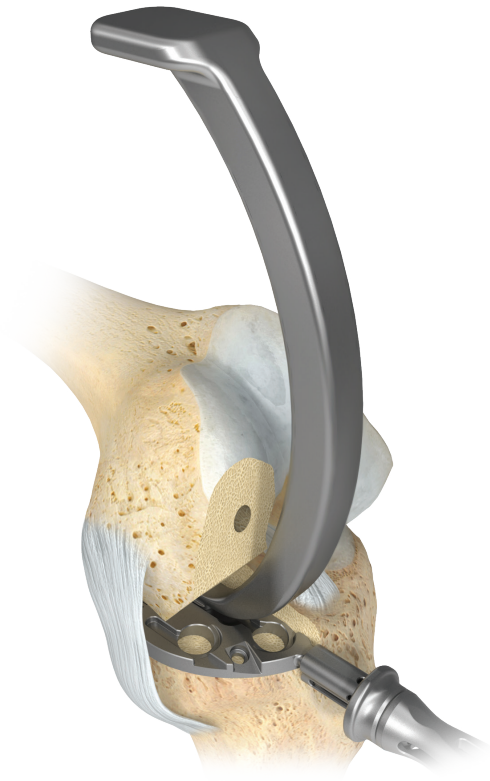

Figure 46

Finish the Tibia (cont.)

Proper placement of the tibial trial can be accomplished by directing the PK handle posterior until the anterior stop on the handle contacts the anterior tibial bone (Figure 45). Use the handle to drive the keel into the bone.

If necessary, insert the tibial impactor into the recess on the tibial trial and impact so it sits flush on the tibial surface (Figure 46). If sclerotic bone requires additional preparation for the keel, score the marked bone surface with sagittal saw or narrow chisel before inserting the tibial trial.

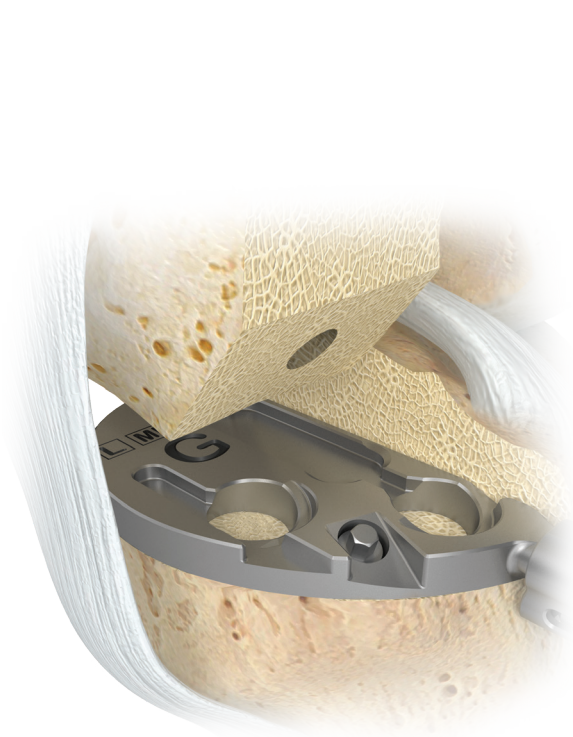

Figure 47

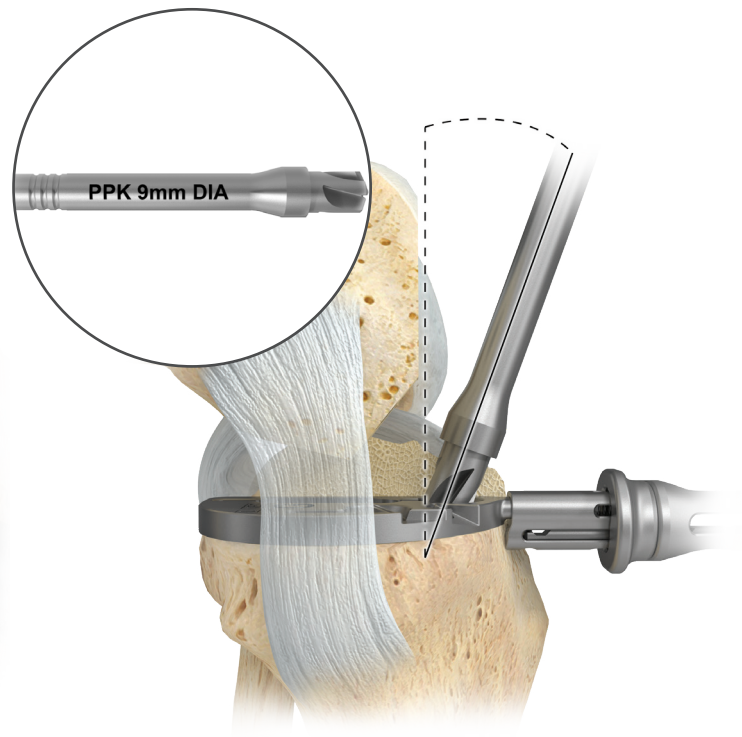

Figure 48

Finish the Tibia (cont.)

With the appropriate size tibial trial in place and flush on the tibial surface, insert the 33 mm headed screw into the anterior fixation hole (Figure 47). It is important to keep the PK handle attached when securing with the 33 mm headed screw in order to resist posterior shift of the tibial trial in the event overtightening of the 33 mm headed screw occurs.

There are two different part numbers for tibial peg drills. They both perform the same function, but one is specific to the Persona Partial Knee System, will take 2mm less bone from the tibia, has three engraved rings around the shaft of the drill and has “PPK” etched on the shaft (Figure 48 Inset).

The angle for drilling the tibial peg holes is 20 degrees, not perpendicular to the tibial trial. Align the tibial drill to the face of the 20 degree counterbore peg holes drilling to the drill stop (Figure 48). Remove the PK handle and leave the tibial trial in place to perform trial reduction.

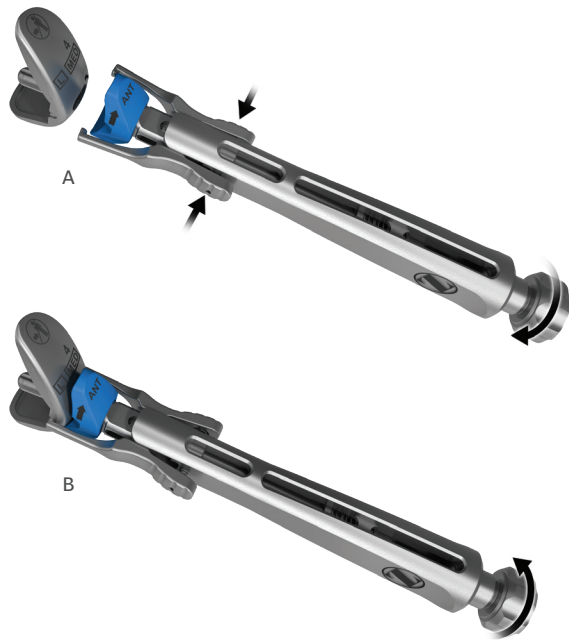

Figure 49

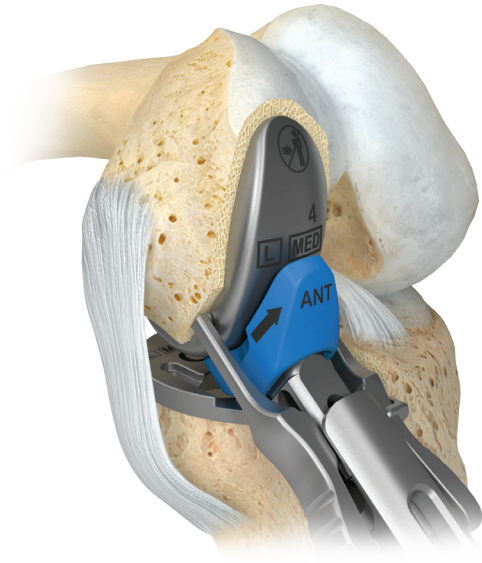

Figure 50

Perform Trial Reduction

With all bone surfaces prepared, perform a trial reduction with the appropriate size femoral trial, tibial trial, and trial bearing. Attach the PK locking femoral impactor to the femoral trial component (Figure 49). This is performed by first ensuring the impaction pad is assembled to the impactor. Next, ensure the lock nut is disengaged (confirmed by rotating the lock nut counter clockwise until the threads are disengaged). Pinch the arms back to open the jaws and attach the jaws to the notches on the medial and lateral sides of the femoral trial ensuring the orientation of the femoral trial aligns with the marking on the impactor pad (ANT designates anterior, POST designates posterior). Lock the femoral trial to the PK locking impactor by rotating the lock nut clockwise until resistance is felt.

With the knee flexed, use the PK locking femoral impactor and insert the femoral trial (Figure 50). Insert the posterior (longer) peg first and impact the trial onto the femur with a mallet and ensure the anterior peg engages and the component is fully seated. Remove the PK locking femoral impactor by rotating the lock nut counter-clockwise (approximately 1 rotation) and pinching the arms to open the jaws.

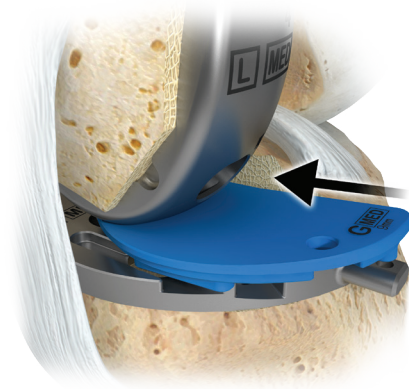

Figure 51



Figure 53

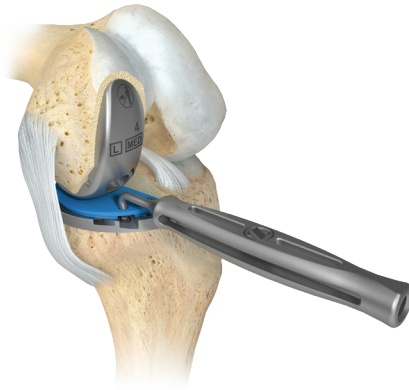

Figure 52

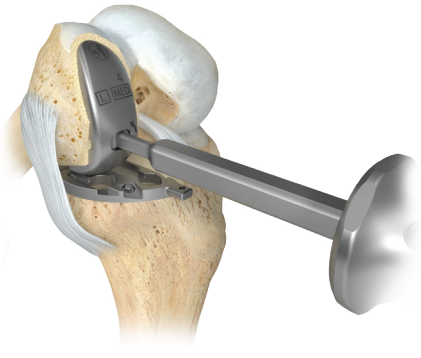

Figure 54

Perform Trial Reduction (cont.)

Next select the appropriately sized trial bearing and slide into the grooves on the tibial trial (Figure 51).

Note: Care must be taken to ensure there is nothing between the tibial trial and trial bearing when it is inserted.

With all trials in place manipulate the knee through a full range of motion to determine stability of the joint. Mid flexion clunk on the trials may occur due to the extraction hole in the femoral trial. Before final implantation check limb alignment one final time. It is important to ensure a slight under correction of the limb alignment and have appropriate ligamentous tension restored (2 - 3 mm of laxity) in flexion and extension.

Insert the 2 mm end of the tension gauge (“amber stick”) in flexion and extension to ensure that the gaps are not too tight (Figure 53). If trial bearing thickness exchange is required remove the trial bearing using the trial bearing remover (Figure 52). Once size and thickness of the components are confirmed, remove the trial components. Use the slaphammer for removal of the femoral trial (Figure 54). Insert the oval end of the slaphammer into the oval pocket on the femoral trial. Rotate the slaphammer 90 degrees medial (clockwise on a right knee, counter clockwise on a left knee).

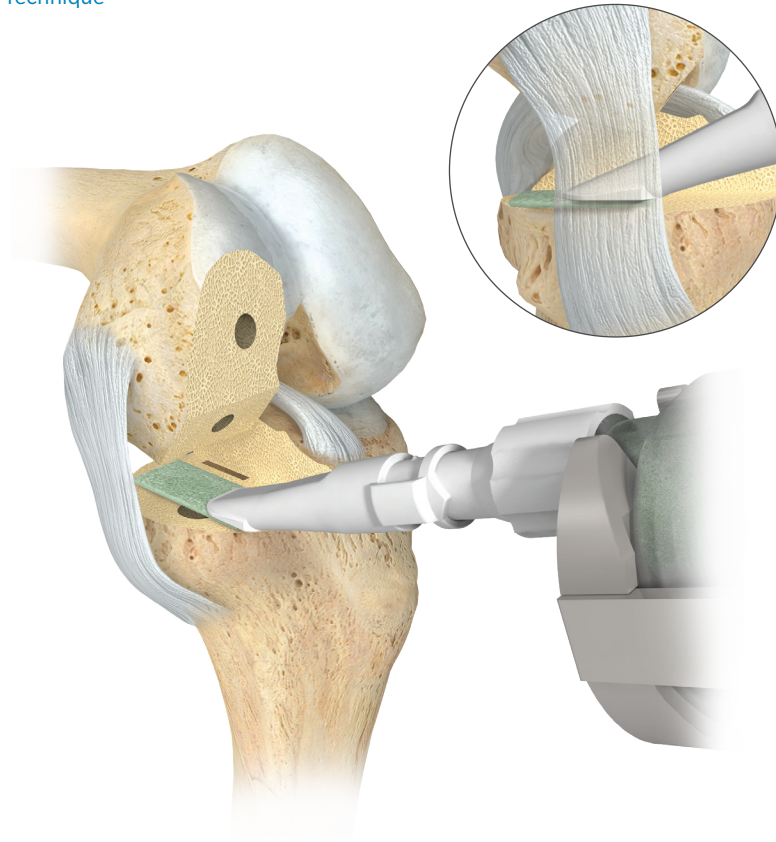

Figure 55

Implanting Final Components

Obtain the final components. Due to space constraints the tibial component should be implanted first.

Tibia

If a tourniquet above the knee is not already in use, place and/or inflate throughout preparation of bone for cementation, as well as mixing, application and hardening of bone cement. If the tibial and femoral bone is dense or sclerotic, perforate the knee by drilling or punching an array of 2 mm holes, 2-3 mm deep, spaced 5 to 8 mm apart to improve cement penetration.

Cleanse all cement-receiving bone surfaces thoroughly using pulse lavage and dry with a clean, dry lap sponge. Next, mix a single 40g unit of cement. Use of a vacuum mixing cartridge is recommended as well as application of new gloves.

As soon as cement properties permit, apply a thin layer of cement over the entire underside of the tibial component. The cement should just overfill the pockets on the underside of the tray, up to 1 mm proud posteriorly and 2 mm proud anteriorly. Avoid contamination of the component-cement interface.

Apply cement to the tibia and pressurize the cement, striving for penetration of 3-4 mm.

- Use of a cement gun/cartridge equipped with a pressurizing nozzle is recommended to deliver and pressurize cement into the prepared holes and across the flat surface.
- Alternatively, cement may be applied manually and pressurized into the bone using a ½ inch (12.7 mm) or wider flat osteotome.

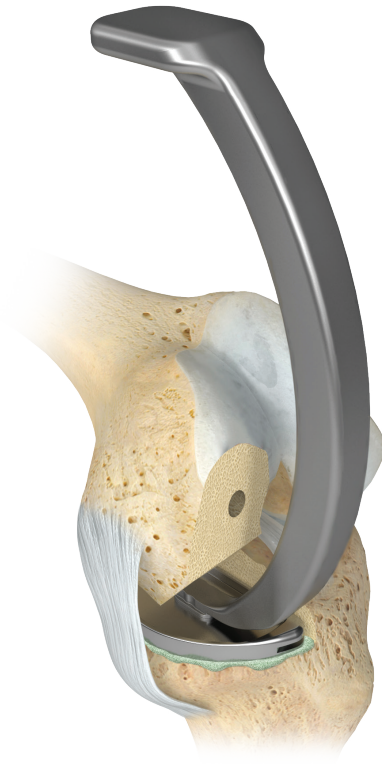

Figure 56

Implanting Final Components (cont.)

After pressurization, all cement that remains proud of the bone should be removed. A ½ inch (12.7 mm) curved osteotome, concave down, is useful to scrape away excess cement. If there is significant blood or saline on the cement surface, it can be carefully dried using a flat osteotome wrapped in a clean, dry lap sponge prior to final component placement. While drying blood or saline, make sure not to remove the cement that was just placed onto the surface.

To facilitate insertion, flex the knee and externally rotate the tibia. Press down on the posterior portion of the tibial component first to force excess cement anteriorly. Then press down on the anterior portion of the component.

Using the tibia plate impactor, impact the tibial component moving from posterior to anterior until fully seated (Figure 56). Remove any excess cement from posterior aspect of the tibia using the curved tonsile/hemostat provided.

The curved tonsile/hemostat can also be used to remove excess cement from the anterior aspect of the tibial tray.

Confirm that all cement has been removed from the proximal surface of the tibial component especially posterior near the locking mechanism. Any cement remaining will prevent the proper assembly of the trial bearing.

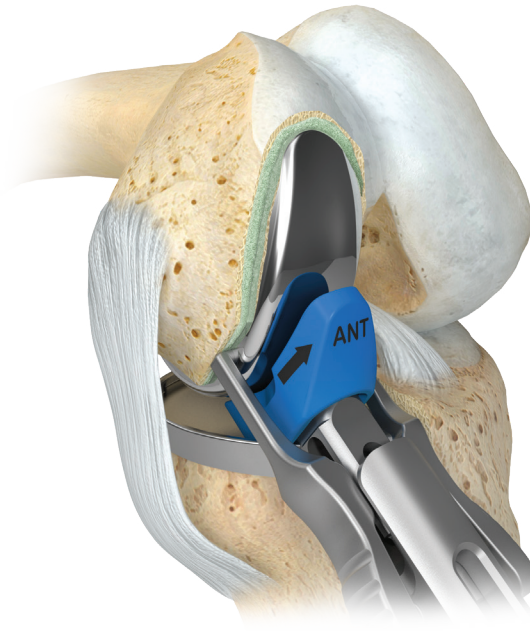

Figure 57

Implanting Final Components (cont.)

Femur

While mixing another 40g unit of cement, pulse lavage and dry the femoral side again. As soon as cement properties permit, apply a layer of cement over the entire bone-opposing surface of the femoral component. The cement should overfill the pockets on the distal and chamfer facet by 2-3 mm and on the posterior facet by 1-2 mm. Avoid contamination of the component-cement interface.

Apply cement to the prepared femur and pressurize the cement, striving for penetration of 3-4 mm.

- Use of a cement gun/cartridge equipped with a pressurizing nozzle is recommended.
- Alternatively, cement may be applied and pressurized manually.

Any cement remaining proud on the posterior facet should be scraped flush to the bone before proceeding so that it is not displaced and inaccessible upon seating the femoral component. With the femoral component assembled to the PK locking femoral impactor, begin the femoral component insertion with the leg in deep flexion. Insert the posterior (longer) peg first and impact the femoral component onto the femur with a mallet and ensure the anterior peg engages and the component is fully seated. The femoral impactor can be used to help fully seat the femoral component (Figure 57).

Remove excess cement in a routine manner.

Confirm that all cement has been removed from the proximal surface of the tibial component especially posterior near the locking mechanism. Any cement remaining will prevent the proper assembly of the bearing.

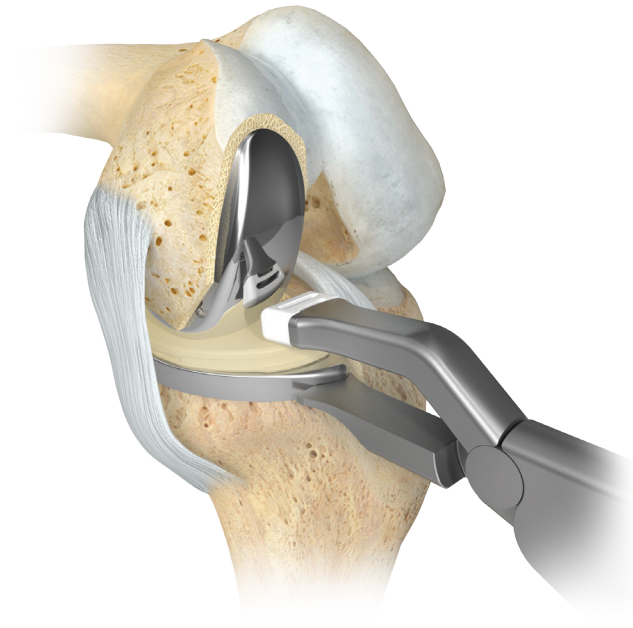

Figure 58

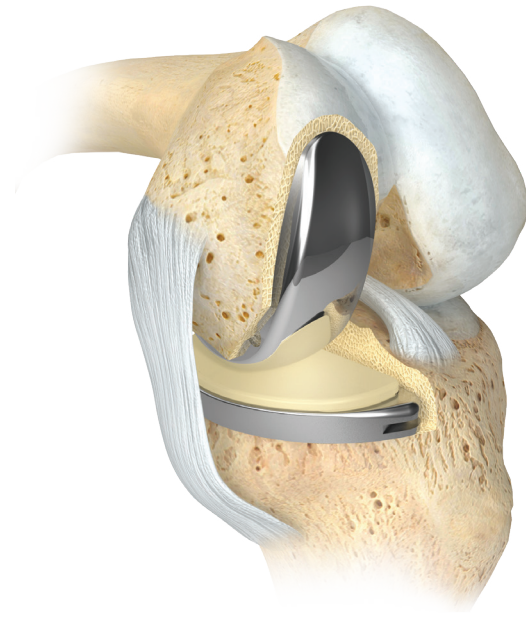

Figure 59

Implanting Final Components (cont.)

Confirm the correct size and thickness of the final bearing component by testing with the trial bearings in maximum flexion and extension. Use the tension gauge (“amber stick”) to assess the flexion and extension gaps. Then recheck alignment to verify that the joint has not been overcorrected.

Bearing Assembly

After the cement has cured, remove any remaining excess cement before the final placement of the tibial bearing. Do not proceed with locking the final bearing component until the cement has fully cured and all cement has been removed from the proximal surface and locking mechanism of the tibia component.

With the engraved side of the component bearing down, slide the posterior edge of the polyethylene component under the posterior tibial component.

Snap the disposable bearing inserter tip onto the tibial bearing inserter. Insert the tab on the lower jaw of the tibial bearing inserter into the notch on the front of the tibial component. Squeeze the handles of the inserter together until the component snaps into place (Figure 58) completing final component implantation (Figure 59).

Closure

Irrigate the knee for the final time and close the wound in a routine manner.

Ordering Information

Femoral Components

Product	Description	Side	Size	Part Number
	Persona Partial Knee Femoral Component	Left Medial	1	42-5580-001-01
			2	42-5580-002-01
			3	42-5580-003-01
			4	42-5580-004-01
			5	42-5580-005-01
			6	42-5580-006-01
			7	42-5580-007-01
		Right Medial	1	42-5580-001-02
			2	42-5580-002-02
			3	42-5580-003-02
			4	42-5580-004-02
			5	42-5580-005-02
			6	42-5580-006-02
			7	42-5580-007-02

Tibial Components

Product	Description	Side	Size	Part Number	
	Persona Partial Knee Tibial Component	Left Medial	C	42-5380-003-01	
			D	42-5380-004-01	
			E	42-5380-005-01	
			F	42-5380-006-01	
			G	42-5380-007-01	
			H	42-5380-008-01	
			J	42-5380-009-01	
			Right Medial	C	42-5380-003-02
				D	42-5380-004-02
		E		42-5380-005-02	
		F		42-5380-006-02	
		G		42-5380-007-02	
		H	42-5380-008-02		
		J	42-5380-009-02		

Bearing Components

Product	Description	Side	Size	Thickness	Part Number
	Persona Partial Knee Vivacit-E® Bearing	Left Medial	C	8	42-5182-003-08
				9	42-5182-003-09
				10	42-5182-003-10
				11	42-5182-003-11
				12	42-5182-003-12
				14	42-5182-003-14
				Right Medial	C
		9	42-5282-003-09		
		10	42-5282-003-10		
		11	42-5282-003-11		
		12	42-5282-003-12		
		14	42-5282-003-14		
		Left Medial	D		
				9	42-5182-004-09
				10	42-5182-004-10
				11	42-5182-004-11
				12	42-5182-004-12
				14	42-5182-004-14
				Right Medial	D
		9	42-5282-004-09		
		10	42-5282-004-10		
		11	42-5282-004-11		
		12	42-5282-004-12		
		14	42-5282-004-14		
		Left Medial	E		
				9	42-5182-005-09
				10	42-5182-005-10
				11	42-5182-005-11
12	42-5182-005-12				
14	42-5182-005-14				
Right Medial	E			8	42-5282-005-08
		9	42-5282-005-09		
		10	42-5282-005-10		
		11	42-5282-005-11		
		12	42-5282-005-12		
		14	42-5282-005-14		

Bearing Components (cont.)

Product	Description	Side	Size	Thickness	Part Number
	Persona Partial Knee Vivacit-E Bearing	Left Medial	F	8	42-5182-006-08
				9	42-5182-006-09
				10	42-5182-006-10
				11	42-5182-006-11
				12	42-5182-006-12
				14	42-5182-006-14
		Right Medial	F	8	42-5282-006-08
				9	42-5282-006-09
				10	42-5282-006-10
				11	42-5282-006-11
				12	42-5282-006-12
				14	42-5282-006-14
		Left Medial	G	8	42-5182-007-08
				9	42-5182-007-09
				10	42-5182-007-10
				11	42-5182-007-11
				12	42-5182-007-12
				14	42-5182-007-14
		Right Medial	G	8	42-5282-007-08
				9	42-5282-007-09
				10	42-5282-007-10
				11	42-5282-007-11
				12	42-5282-007-12
				14	42-5282-007-14
Left Medial	H	8	42-5182-008-08		
		9	42-5182-008-09		
		10	42-5182-008-10		
		11	42-5182-008-11		
		12	42-5182-008-12		
		14	42-5182-008-14		
Right Medial	H	8	42-5282-008-08		
		9	42-5282-008-09		
		10	42-5282-008-10		
		11	42-5282-008-11		
		12	42-5282-008-12		
		14	42-5282-008-14		





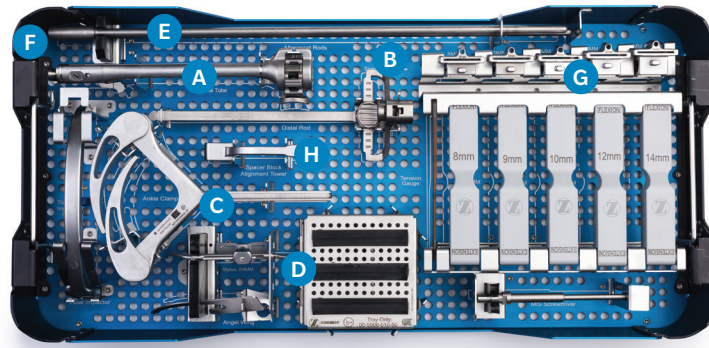



Bearing Components (cont.)

Product	Description	Side	Size	Thickness	Part Number
	Persona Partial Knee Vivacit-E Bearing	Left Medial	J	8	42-5182-009-08
				9	42-5182-009-09
				10	42-5182-009-10
				11	42-5182-009-11
				12	42-5182-009-12
				14	42-5182-009-14
				Right Medial	J
		9	42-5282-009-09		
		10	42-5282-009-10		
		11	42-5282-009-11		
		12	42-5282-009-12		
		14	42-5282-009-14		





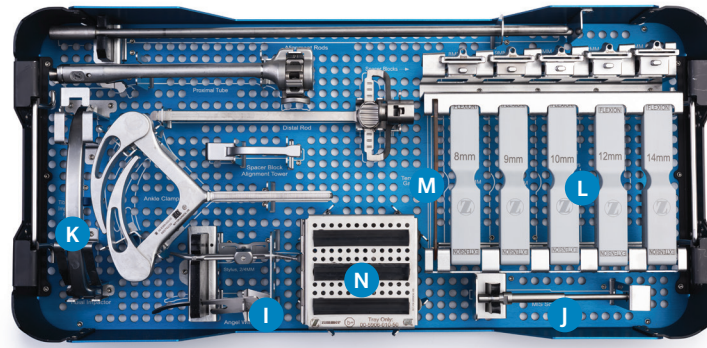

00-5907-083-95 General Instruments Tray 1 (Aluminum)

00-5908-083-95 General Instruments Tray 1 (Stainless Steel)

Product	Description	Label	Size	Part Number
	Persona Proximal Tube	A	–	42-5399-001-00
	Persona Distal Rod	B	–	42-5399-002-00
	Persona Ankle Clamp	C	–	42-5399-003-00
	Persona PK Stylus, 2/4MM	D	–	42-5399-005-24
	Align Rod	E	–	00-5785-079-00
	Align Rod w/Coupler	F	–	00-5785-080-00
	Persona Partial Knee Spacer Block	G	8 mm 9 mm 10 mm 12 mm 14 mm	42-5399-035-08 42-5399-035-09 42-5399-035-10 42-5399-035-12 42-5399-035-14
	Persona Partial Knee Spacer Block Alignment Tower	H	–	42-5399-006-35



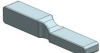
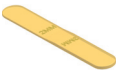



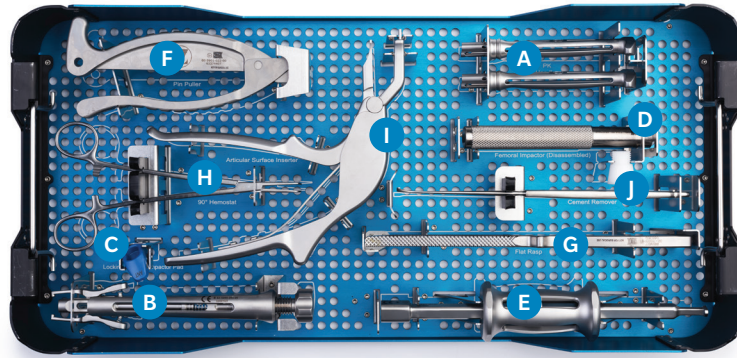



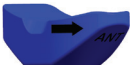

00-5907-083-95 General Instruments Tray 1 cont. (Aluminum)
 00-5908-083-95 General Instruments Tray 1 cont. (Stainless Steel)

Product	Description	Label	Size	Part Number
	Angel Wing	I	–	00-5977-084-10
	MIS Screw Driver	J	–	00-5983-049-00
	Persona Partial Knee Tibia Impactor	K	–	42-5399-090-00
	Persona Partial Knee Flexion/Extension Gap Checker	L	8 mm 9 mm 10 mm 12 mm 14 mm	42-5099-035-08 42-5099-035-09 42-5099-035-10 42-5099-035-12 42-5099-035-14
	Tensor Gauge	M	–	00-5789-071-00
	Pin Caddy	N	–	00-5906-010-50



00-5907-083-96 General Instruments Tray 2 (Aluminum)

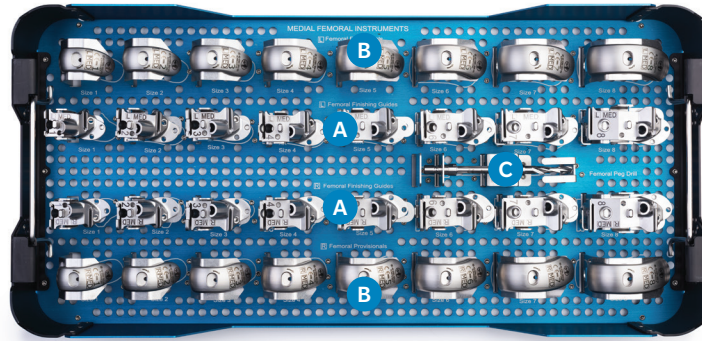

00-5908-083-96 General Instruments Tray 2 (Stainless Steel)

Product	Description	Label	Part Number
	Persona Partial Knee Handle	A	42-5399-017-10
	Persona Partial Knee Locking Femoral Impactor	B	42-5099-091-00
	Persona Partial Knee Locking Femoral Impactor Pad	C	42-5099-090-00
	Femoral Impactor	D	00-1336-028-00
	Persona Partial Knee Slaphammer	E	42-5399-092-00
	Persona Pin Puller	F	00-5901-022-00
	Vanguard XP® Bone Rasp	G	32-700376
	Curved Tonsile/Hemostat	H	00-5789-047-00
	Persona Partial Knee Bearing Inserter	I	42-5299-003-00
	Cement Remover	J	00-5061-084-00





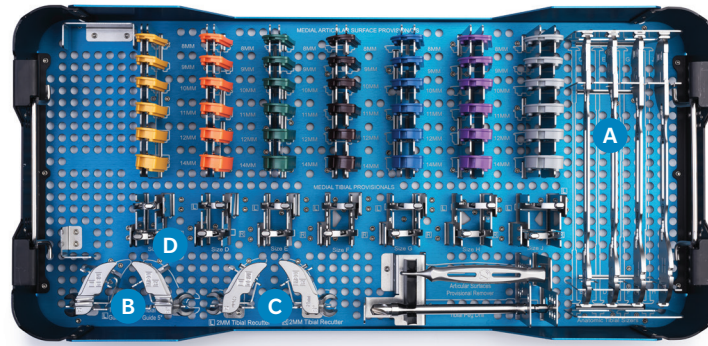

00-5907-083-97 Medial Femoral Tray (Aluminum)

00-5908-083-97 Medial Femoral Tray (Stainless Steel)

Product	Description	Label	Side	Size	Part Number
	Persona Partial Knee Femoral Finishing Guide	A	Left Medial	1	42-5781-001-01
				2	42-5781-002-01
				3	42-5781-003-01
				4	42-5781-004-01
				5	42-5781-005-01
				6	42-5781-006-01
				7	42-5781-007-01
			Right Medial	1	42-5781-001-02
				2	42-5781-002-02
				3	42-5781-003-02
				4	42-5781-004-02
				5	42-5781-005-02
				6	42-5781-006-02
				7	42-5781-007-02
	Persona Partial Knee Femoral Trial	B	Left Medial	1	42-5581-001-01
				2	42-5581-002-01
				3	42-5581-003-01
				4	42-5581-004-01
				5	42-5581-005-01
				6	42-5581-006-01
				7	42-5581-007-01
			Right Medial	1	42-5581-001-02
				2	42-5581-002-02
				3	42-5581-003-02
				4	42-5581-004-02
				5	42-5581-005-02
				6	42-5581-006-02
				7	42-5581-007-02
	Persona Partial Knee Femoral Peg Drill	C	-	-	42-5099-042-00



00-5907-083-98 Medial Tibial Tray (Aluminum)
 00-5908-083-98 Medial Tibial Tray (Stainless Steel)

Product	Description	Label	Side	Size	Part Number
	Persona Partial Knee Anatomic Tibial Sizer	A	Medial	B/C	42-5399-080-34
				D/E	42-5399-080-56
				F/G	42-5399-080-78
				H/J	42-5399-080-90
	Persona Partial Knee 5 Degree Captured Tibial Cut Guide	B	Left Medial	-	42-5399-051-85
			Right Medial	-	42-5399-052-85
	Persona Partial Knee 2 mm Tibial Recutter	C	Left Medial	-	42-5399-053-85
			Right Medial	-	42-5399-059-85
	Persona Partial Knee Tibial Trial	D	Left Medial	C	42-5381-003-01
				D	42-5381-004-01
				E	42-5381-005-01
				F	42-5381-006-01
				G	42-5381-007-01
				H	42-5381-008-01
			Right Medial	J	42-5381-009-01
				C	42-5381-003-02
				D	42-5381-004-02
				E	42-5381-005-02
				F	42-5381-006-02
				G	42-5381-007-02
H	42-5381-008-02				
J	42-5381-009-02				

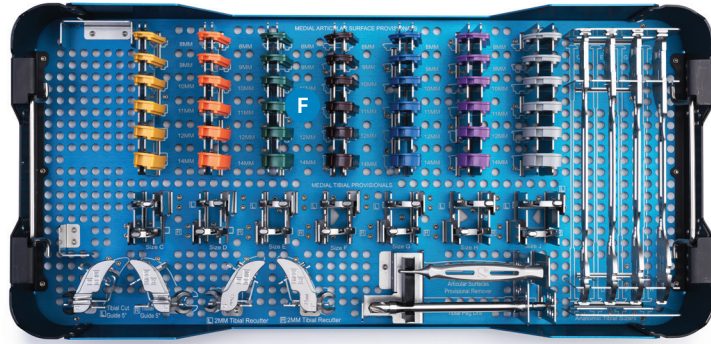

00-5907-083-98 Medial Tibial Tray cont. (Aluminum)

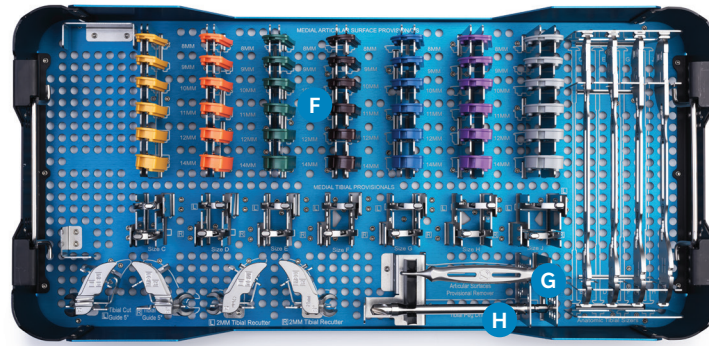

00-5908-083-98 Medial Tibial Tray cont. (Stainless Steel)

Product	Description	Label	Side	Size	Thickness	Part Number
	Persona Partial Knee Trial Bearing	F	Medial	C	8 mm	42-5181-003-08
					9 mm	42-5181-003-09
					10 mm	42-5181-003-10
					11 mm	42-5181-003-11
					12 mm	42-5181-003-12
					14 mm	42-5181-003-14
					D	8 mm
				9 mm		42-5181-004-09
				10 mm		42-5181-004-10
				11 mm		42-5181-004-11
				12 mm		42-5181-004-12
				E	8 mm	42-5181-005-08
					9 mm	42-5181-005-09
					10 mm	42-5181-005-10
					11 mm	42-5181-005-11
					12 mm	42-5181-005-12
				F	8 mm	42-5181-006-08
					9 mm	42-5181-006-09
					10 mm	42-5181-006-10
					11 mm	42-5181-006-11
					12 mm	42-5181-006-12
G	8 mm	42-5181-007-08				
	9 mm	42-5181-007-09				
	10 mm	42-5181-007-10				
	11 mm	42-5181-007-11				
	12 mm	42-5181-007-12				
					14 mm	42-5181-007-14







00-5907-083-98 Medial Tibial Tray cont. (Aluminum)

00-5908-083-98 Medial Tibial Tray cont. (Stainless Steel)

Product	Description	Label	Side	Size	Thickness	Part Number				
	Persona Partial Knee Trial Bearing	F	Medial	H	8 mm	42-5181-008-08				
					9 mm	42-5181-008-09				
					10 mm	42-5181-008-10				
					11 mm	42-5181-008-11				
					12 mm	42-5181-008-12				
					14 mm	42-5181-008-14				
				J	8 mm	42-5181-009-08				
					9 mm	42-5181-009-09				
					10 mm	42-5181-009-10				
					11 mm	42-5181-009-11				
					12 mm	42-5181-009-12				
					14 mm	42-5181-009-14				
					Persona Partial Knee Trial Bearing Remover	G	-	-	-	42-5399-017-03
					Tibial Drill With Stop	H	-	-	-	42-5399-049-00

Single-Use Disposables (Ordered Separately)

Product	Description	Label	Side	Size	Part Number
	Persona Partial Knee Bearing Inserter Tip	-	-	-	42-5299-003-01
	Trocar Pins (4/Box)	-	-	-	00-5901-020-00
	Headed Screw (1/Box)	-	-	48 mm	00-5983-040-48
	Headed Screw (1/Box)	-	-	33 mm	00-5983-040-33
	23 degree pressurizing nozzle – OUS only	-	-	-	4148
	23 Degree pressurizing nozzle – US only	-	-	-	110030623

Appendix I

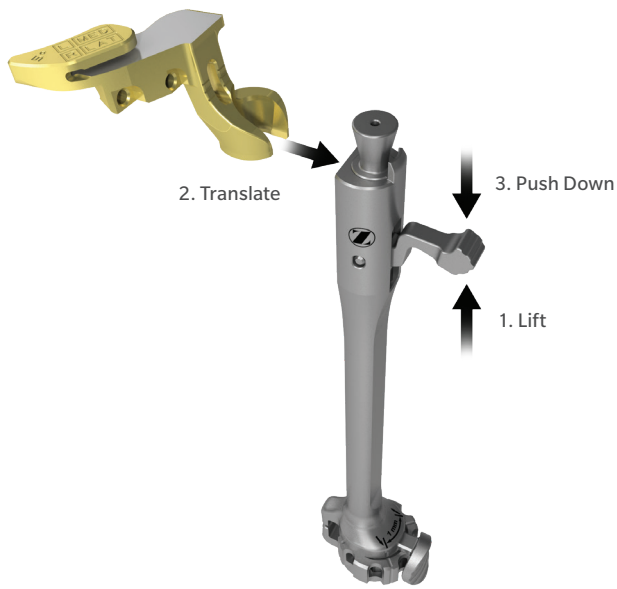

Figure 5



Figure 6

Proximal Tibial Resection

In this technique, there are two instrumentation options for making the proximal tibial resection, which are called Option 1 and Option 2. The main differences in these options are:

Option 1 provides a captured vertical cut with a corner pin that acts as a saw stop. The primary guides and recutters are stainless steel.

Option 2 provides an uncaptured vertical cut, with the vertical cut landing on top of the cut guide as a reference. The primary cutters and recutters are nitride-coated, which makes them gold colored.

- The pin locations differ slightly between the guides, therefore the primary guides and recutters **cannot be interchanged between options**.

The technique for option 2 starts on this page.

Option 2: Proximal Tibial Resection

Assemble the extramedullary (EM) alignment guide. Attach the tibial cut guide to the EM alignment guide by lifting the lever of the EM proximal tube translating the tibial cut guide onto the top of the EM proximal tube, under the locking cone. Secure by pushing the lever on the EM proximal tube down to lock the tibial cut guide in place (Figure 5). The tibial cut guide and associated recutters will be gold-colored nitride coated on the medial portion on the top of the guide (Figure 5 inset). Ensure all tibial cut guides and recutters in the instrument set are gold nitride-coated.

Depress and hold the button on the EM distal rod and insert the threaded rod on the EM ankle clamp into the EM distal rod and release the button. Depress and hold the button on the distal end of the EM proximal tube and insert the EM distal rod into the EM proximal tube and release the button (Figure 6).

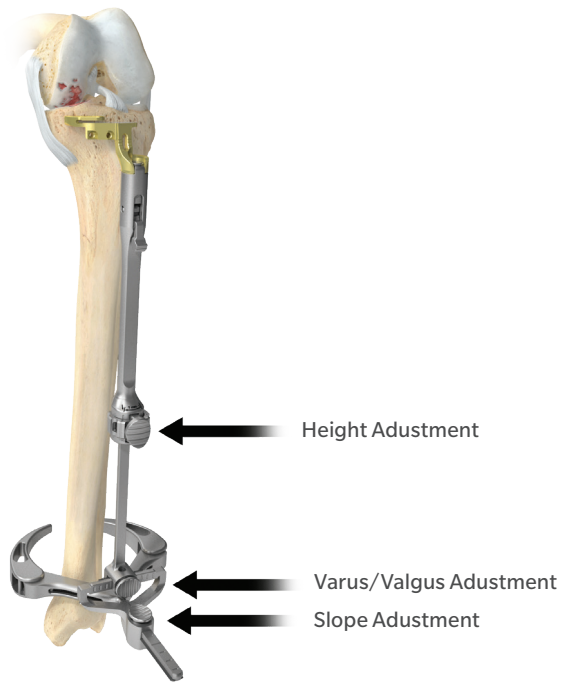

Figure 7

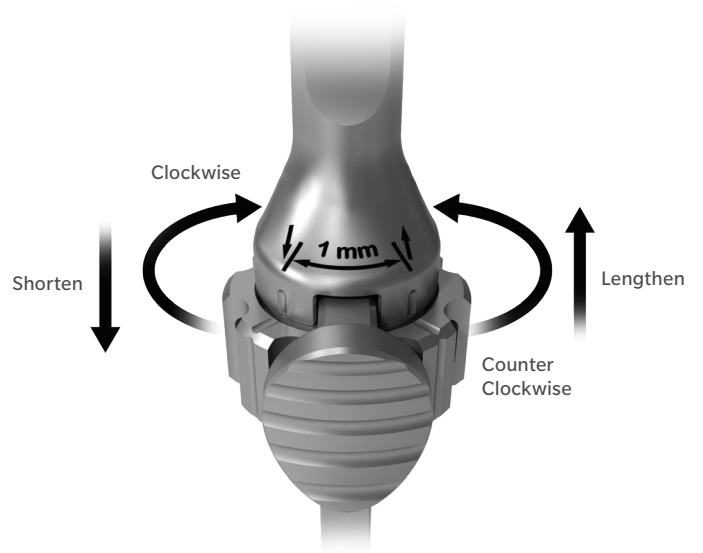

Figure 8

Proximal Tibial Resection (cont.)

The buttons shown in Figure 7 are used to adjust the tibial cut guide in the following manner: varus/valgus angle, posterior slope, and the height or depth of resection. The height adjustment button can be depressed for macro-adjustment or the dial can be rotated for micro-adjustment.

One full rotation of the dial equals 4 mm of height adjustment and $\frac{1}{4}$ turn equals 1 mm of height adjustment (Figure 8). Rotating the height adjustment dial clockwise lowers the EM alignment guide for resecting more tibia. Rotating the dial counterclockwise raises the EM alignment guide for resecting less tibia.

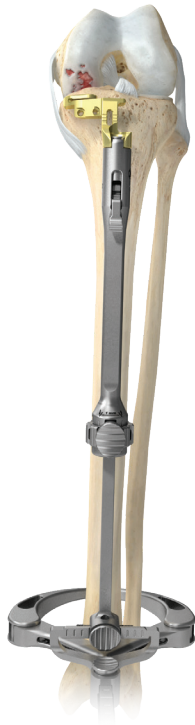

Figure 9



Figure 10

Proximal Tibial Resection (cont.)

Secure the distal portion of the assembly by placing the spring arms of the EM ankle clamp around the ankle proximal to the malleoli. Use the posterior slope adjustment and varus/valgus adjustment to set the EM alignment guide parallel with the long axis of the tibia in both frontal (Figure 9) and sagittal (Figure 10) planes.

This will set the tibial resection perpendicular to the mechanical axis with 5 degrees of posterior slope. The tibial cut guide has 5 degrees of posterior slope built in. Correct rotation can be achieved from lining up the guide on the tibial tubercle proximally (junction of middle and medial third) and the center of the talus distally (medial to the midpoint of the ankle).

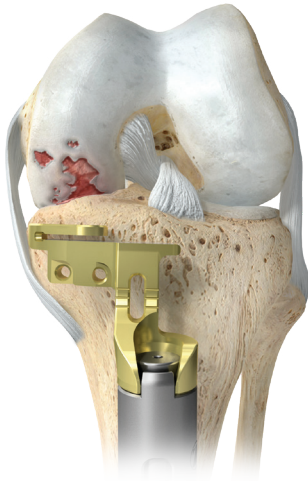

Figure 11

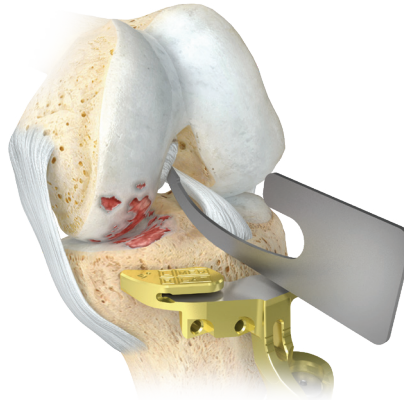

Figure 12



Figure 13

Proximal Tibial Resection (cont.)

Use the height adjustment to set the tibial cut guide at the approximate resection level (Figure 11). Position the tibial cut guide so that the resection plane for the vertical (sagittal) cut will land on the uncaptured portion of the guide. The vertical cut should be placed adjacent to the medial fibers of the ACL attachment and pass just medial to the apex of the medial tibial spine. The goal is to obtain optimal coverage of the tibial plateau, so the M/L position should be as far lateral as possible without impinging on the insertion of the ACL. The angel wing can be used to visualize the placement of the vertical cut (Figure 12).

Insert a headless trocar pin through the center of the 7.2mm vertical slot to set the initial location of the guide (Figure 13).

- ⓘ **Technique Tip:** It is important to insert the headless trocar pin through the center of the 7.2 mm vertical slot when setting the position of the sagittal cut slot. This allows adjustment both up and down to set the optimal depth of the tibial cut.
- ⓘ **Technique Tip:** When using any headless trocar pin, it is important to leave 10 mm or more of the pin exposed. This will allow for ease of removal when using the pin puller.

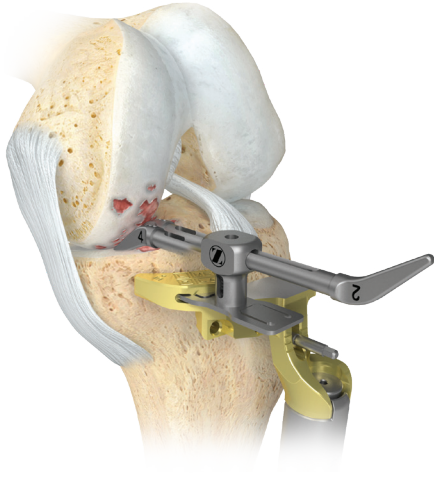

Figure 14

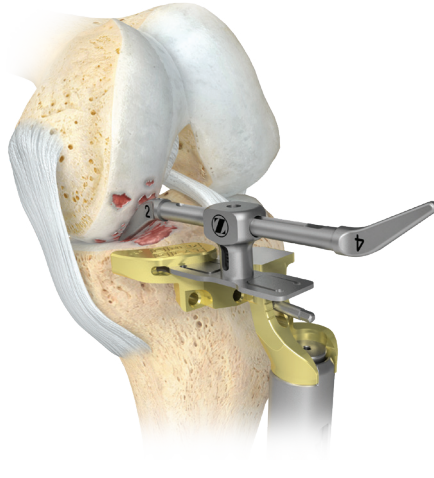

Figure 15

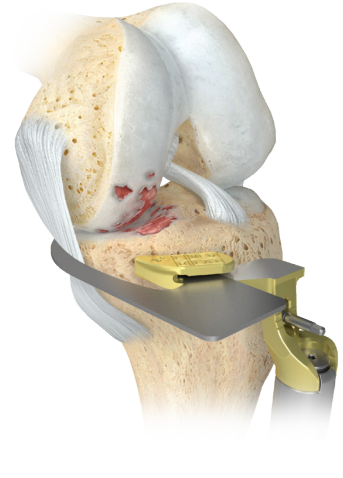

Figure 16

Proximal Tibial Resection (cont.)

Insert the foot of the tibial stylus into the cutting slot of the tibial cut guide (Figure 14). Using the 4 mm tip of the stylus, adjust the final height of the tibial cut guide by rotating the micro-adjustment of the EM proximal tube clockwise (downward adjustment) or counter clockwise (upward adjustment) to contact the tibial stylus tip to the lowest point of the worn antero-medial tibial plateau (Figure 14).

A thinner cut may be desired if there is severe wear of the tibia. In this case, the 2 mm tip of the stylus can be used (Figure 15). An angel wing can be placed through the cut slot on the tibial cut guide to confirm the desired level and slope of the proximal tibial resection (Figure 16). If more or less slope is required this can be adjusted by using the slope adjustment buttons of the EM alignment guide.

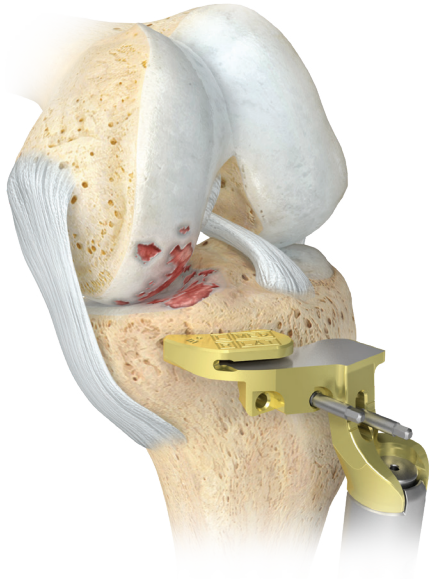

Figure 17

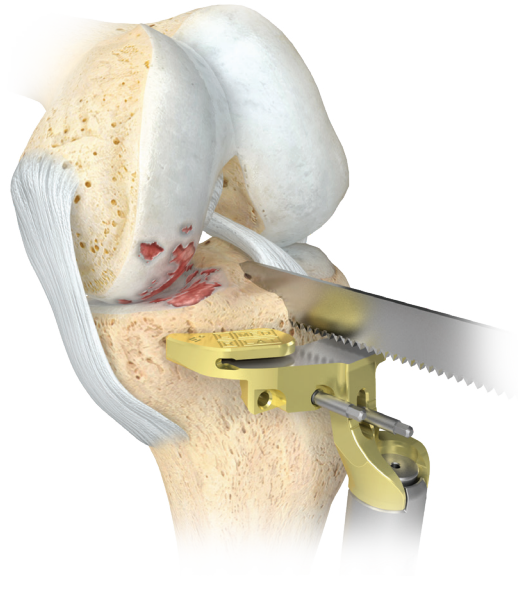

Figure 18

Proximal Tibial Resection (cont.)

Secure the tibial cut guide by inserting a headless trocar pin through the parallel hole of the tibial cut guide (Figure 17). Ensure the guide does not move when the pin is being placed into the parallel hole.

If extra stability of the guide is needed, a third, oblique screw hole is an option. Only the 48mm headed screw should be used in this hole. If this option is used, the headed screw must be removed before removing the guide.

☰ Technique Tip: When using any headless trocar pin in the vertical slot or parallel hole, it is important to leave 10 mm or more of the pin exposed. This will allow for ease of removal when using the pin puller.

The sagittal cut can now be made. Bring the reciprocating saw blade down onto the uncaptured landing of the guide. The saw cut should be just medial to the apex of the medial tibial spine and pass medial to or just through the medial edge of the ACL insertion (Figure 18) to follow the marked/scored line. The goal is to obtain the largest area of the tibial plateau possible, so the M/L position should be as far lateral as possible without impinging on the insertion of the ACL. The angel wing can be used to visualize the placement of the vertical cut.

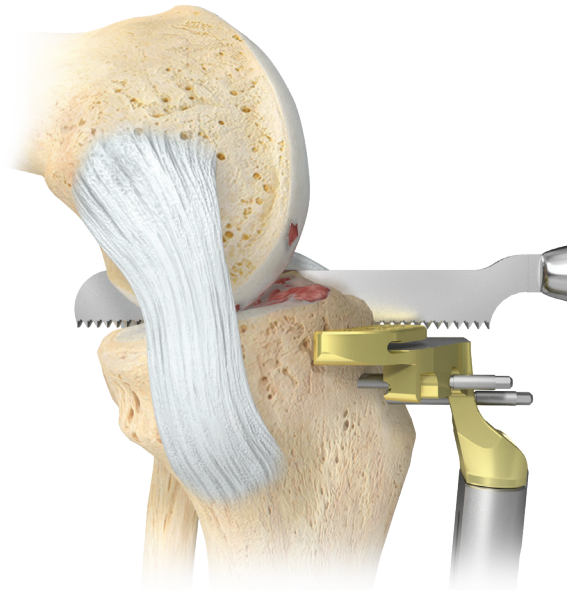

Figure 19

Proximal Tibial Resection (cont.)

Ensure the saw reaches the back of the tibial plateau and a little beyond advancing the saw vertically down until it makes contact with the uncaptured portion of the cut guide. Do not lift the saw handle as this will lead to a vertical cut below the horizontal cut surface and increase the risk of post-operative tibial plateau fracture (Figure 19).

🔑 **Technique Tip:** Avoid damaging the posterior popliteal area by using a blunt tip reciprocating blade.

Before making the horizontal cut insert a medial collateral ligament (MCL) retractor. Ensure this retractor lies between the saw and the MCL, protecting the deep fibers of the ligament. Use a 1.27 mm (0.050 - inch) x 12.5/13 mm oscillating blade through the cut slot in the tibial cut guide to make the horizontal tibial cut. Ensure the saw blade is guided along the MCL retractor to cut the medial cortex completely without damaging the MCL. When the cut is complete the plateau usually can be seen to move freely.



Figure 20

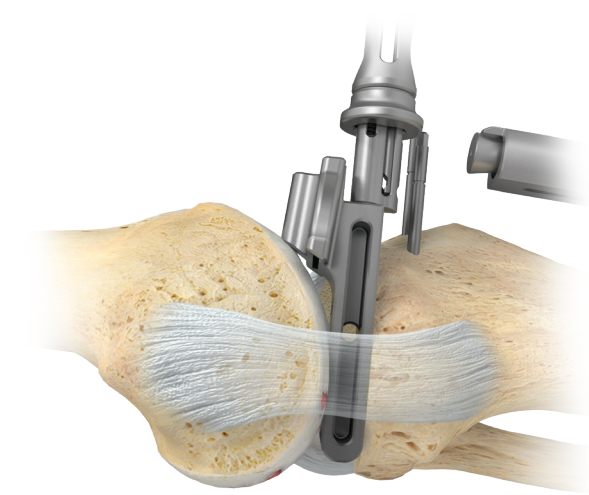

Figure 21



Figure 22

Verifying the Tibial Cut

Place an osteotome into the horizontal osteotomy and lift it upwards to remove the resected tibial plateau. Flexing the knee 10-15 degrees may assist with removal of the resected tibial plateau. Soft tissue attachments posteromedial may need to be released with a bovie or a knife. Examination of the excised tibial plateau should show the features typical of anteromedial arthritis (Figure 20), full thickness cartilage loss anteriorly and relative preservation of the cartilage posteriorly. If this pattern is not observed re-assess the status of the ACL. The excised plateau can be examined to check if the desired posterior slope has been achieved.

Remove the tibial cut guide from the EM alignment guide leaving the EM alignment guide in place along with headless trocar pins used to secure the tibial cut guide (the pin in the corner hole will be removed with the excised plateau). Attach the PK (Partial Knee) handle to the 9 mm spacer block to facilitate insertion of the spacer block into the joint space. With the knee flexed to 5 – 10 degrees insert the 9 mm spacer block to ensure the tibial resection is sufficient (Figure 21).

The thickness is correct when the 9 mm spacer block can slide easily in and out. If the 9 mm spacer block is too loose, use a thicker spacer block to fill the extension gap.

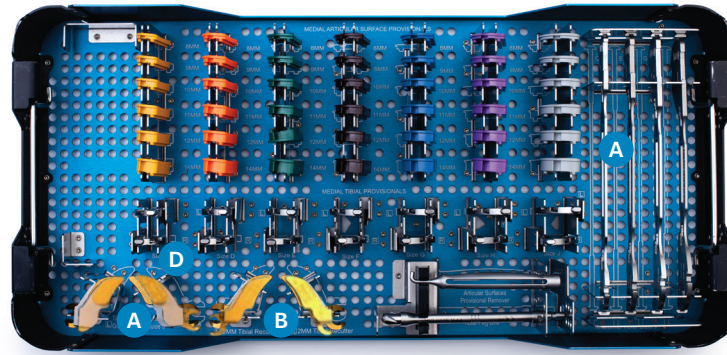

If the 9 mm spacer block or handle has to be firmly gripped to slide in and out, this is too tight, additional tibial resection is required. To re-cut the proximal tibia, apply the 2 mm recutter over the headless trocar pins and reattach the EM alignment guide (Figure 22). A 48mm headed screw can be inserted into the oblique hole if additional fixation is necessary. Use an oscillating saw with a 1.27 mm (0.050-inch) x 12.5/13 mm blade to cut the tibia through the horizontal slot in the 2 mm recutter taking care to avoid undercutting the tibial eminence. Remove the 2 mm recutter and re-check the extension gap with the 9 mm spacer block to ensure the tibial resection is now sufficient.

☰ Technique Tip: It is recommended to use a 9 mm spacer block instead of an 8 mm spacer block as a 9 mm spacer allows the surgeon intraoperative flexibility of +/- 1 mm



00-5907-083-98 Medial Tibial Tray (Aluminum)

00-5908-083-98 Medial Tibial Tray (Stainless Steel)

Product	Description	Label	Side	Size	Part Number
	Persona Partial Knee 5 Degree Captured Tibial Cut Guide	A	Left Medial Right Medial	– –	42-5399-051-95 42-5399-052-95
	Persona Partial Knee 2 mm Tibial Recutter	B	Left Medial Right Medial	– –	42-5399-053-95 42-5399-054-95

All content herein is protected by copyright, trademarks and other intellectual property rights, as applicable, owned by or licensed to Zimmer Biomet or its affiliates unless otherwise indicated, and must not be redistributed, duplicated or disclosed, in whole or in part, without the express written consent of Zimmer Biomet.

This material is intended for health care professionals, Zimmer Biomet employees and the Zimmer Biomet sales force. Distribution to any other recipient is prohibited. Not intended for surgeons practicing medicine in France.

For product information, including indications, contraindications, warnings, precautions, potential adverse effects, and patient counseling information, see the package insert and www.zimmerbiomet.com.

Check for country product clearances and reference product specific instructions for use (package insert). Not all products are registered in all jurisdictions.

Zimmer Biomet does not practice medicine. This technique was developed in conjunction with health care professionals. This document is intended for surgeons and is not intended for laypersons. Each surgeon should exercise his or her own independent judgment in the diagnosis and treatment of an individual patient, and this information does not purport to replace the comprehensive training surgeons have received. As with all surgical procedures, the technique used in each case will depend on the surgeon's medical judgment as the best treatment for each patient. Results will vary based on health, weight, activity and other variables. Not all patients are candidates for this product and/or procedure.

Not for distribution in France.

Caution: Federal (USA) law restricts this device to sale by or on the order of a surgeon. Rx only.

©2020 Zimmer Biomet

 **Legal Manufacturer**
Zimmer, Inc.
1800 W. Center Street
Warsaw, Indiana 46580
USA

 **Legal Manufacturer**
Biomet Orthopedics
P.O. Box 587
56 E. Bell Drive
Warsaw, Indiana 46581-0587
USA



1222.5-GLBL-en-REV0220

www.zimmerbiomet.com

 2797

CE mark on a surgical technique is not valid unless there is a CE mark on the product label.