CHALLENGER

Natural Gas to Propane Instructions



Kit Part Number: CCRKIT64

Kit Includes:

- Rating Label
- Conversion Label
- (4) Propane Gas Orifices
- T-15 Torx Wrench

Recommended Tools:

- Phillips-Head Screwdriver
- Standard Adjustable Wrenches
- Calibrated Combustion Analyzer

 **WARNING**

Indicates a potentially hazardous situation which, if ignored, can result in serious injury or substantial property damage.

NOTICE

Indicates special instructions on installation, operation or maintenance, which are important to equipment but not related to personal injury hazards.

 **WARNING**

This conversion kit shall be installed by a qualified service agency in accordance with the manufacturer's instructions and all applicable codes and requirements of the authority having jurisdiction. If the information in these instructions is not followed exactly, a fire, an explosion or production of carbon monoxide may result causing property damage, personal injury or loss of life. The qualified service agency is responsible for the proper installation of this kit. This installation is not proper and complete until the operation of the converted appliance is checked as specified in the manufacturer's instructions supplied with the kit.

 **CAUTION**

The gas supply shall be shut off prior to disconnecting the electrical power, before proceeding with the conversion.

 **WARNING**

For your safety, turn off electrical power supply at service panel and allow appliance to cool before proceeding. Failure to do so can cause severe personal injury or death.

 **WARNING**

Failure to follow instructions below can result in severe personal injury or damage if ignored:

- Instructions are for a qualified installer / service technician.
- Read all instructions before proceeding.
- Follow instructions in the proper order.

NOTICE

Upon completion of the conversion from Natural Gas to Propane, affix the new rating label included in the kit to the appliance just below the existing rating label on the right side jacket panel. **DO NOT** affix the new label over the existing rating label. Add propane conversion labeling to the gas valve. Complete the Installation Record by recording the combustion readings in the Challenger Installation and Maintenance Manual.

CHALLENGER

Natural Gas to Propane Instructions

Installation of the Propane Gas Orifice

1. Close the manual gas shut off valve to the appliance.
2. Turn off the electrical power supply to the appliance.
3. Remove the front panel by flipping down the control panel and loosening the two Phillips head mounting screw(s) at the control panel. Pull bottom of front panel forward to remove.
4. Disconnect the gas piping inside the CHALLENGER enclosure at the brass union located above the gas valve, and rotate piping towards the back of appliance, see Fig. 1.

NOTICE

The gas orifice is installed in a O-ring gasket. This O-ring gasket must be reinstalled when ever the gas orifice is changed. Use care not to damage the O-ring gasket.

5. Separate the O-ring gasket from the natural gas orifice and insert the appropriate brass propane orifice from Table 1 into the O-ring gasket.

NOTICE

The CHALLENGER appliances contain a natural gas orifice. This orifice must be removed prior to the installation of the propane orifice.

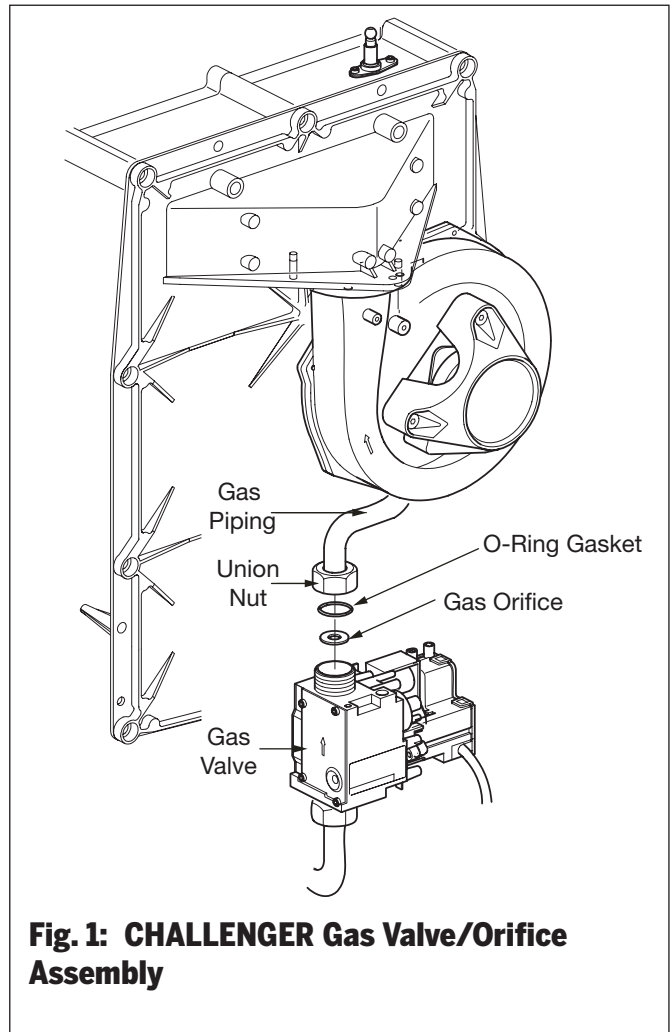

Fig. 1: CHALLENGER Gas Valve/Orifice Assembly



Failure to retain the O-ring gasket on the gas orifice will cause an improper seal between the gas valve and the union resulting in a potential risk of a gas leak. Ensure unions at top and bottom of gas valve are tight. Any potential gas leakage may result in death, serious injury or substantial property damage.



Ensure the proper orifice for propane is installed as given in Table 1. Failure to comply will affect input rate and combustion efficiency of the appliance which may result in death, serious injury or substantial property damage.

Table 1: Propane Gas Orifice

CHALLENGER MODEL	Propane Gas Orifice Size	Orifice Marking
CC50s	0.130" [3.30 mm]	330
CC85 or CC85s	0.199" [5.05 mm]	505
CC105 or CC105s	0.199" [5.05 mm]	505
CC125, CC125c or CC125s	0.220" [5.60 mm]	-580-
CC125H or CC125Hs	0.181" [4.60 mm]	460
CC150s	0.220" [5.60 mm]	-580-

6. Install proper propane gas orifice/O-ring gasket assembly on the top of the gas valve.
7. Reconnect the gas piping on top of gas valve and tighten the brass union connections at the gas valve.

CHALLENGER

Natural Gas to Propane Instructions

- Open the manual gas shut off valve. Before placing the CHALLENGER back into operation check and test all gas connections for leaks. Repair leaks if found.

WARNING

Do not check for gas leaks with an open flame. Use a bubble test. Failure to check for gas leaks can cause severe personal injury, death or substantial property damage.

Inspect Ignition Electrode

NOTICE

Inspection of the ignition electrode is not required on a brand new previously unfired CHALLENGER unless after completing the gas conversion, ignition issues are present. Verify smooth ignition performance after completing the gas conversion to determine if the electrode may require inspection.

WARNING

Prior to inspecting the ignition electrode, ensure all electrical power supply to the appliance is turned off to avoid electrical shock.

- Remove the ignition electrode using the T-15 Torx wrench.
- Remove any white oxides accumulated on the electrode using fine grit sandpaper or steel wool. If the electrode does not clean to a satisfactory condition, replace the ignitor.
- Check igniter to Fig. 2
- When replacing the ignition electrode, ensure the gasket is in good condition and correctly positioned, replace gasket if necessary.

Check Inlet Gas Supply Pressure

- Turn on the electrical power supply to the CHALLENGER.

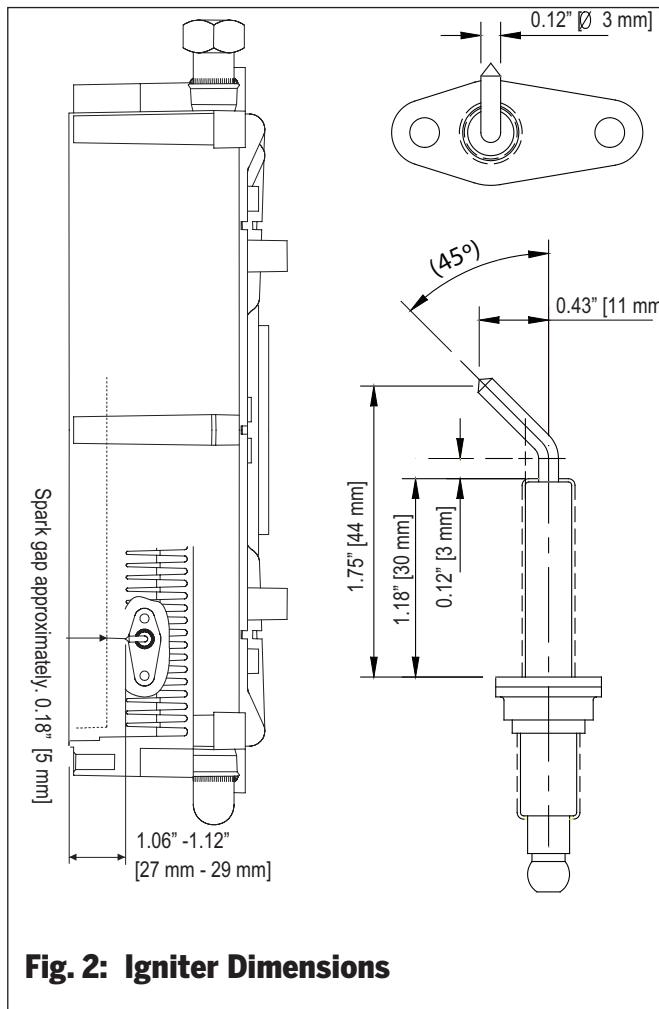

- Check the inlet gas supply pressure to the CHALLENGER at the gas valve see Figs. 3 & 4. Ensure a minimum pressure of 5" w.c [13 mbar] during flow conditions with all gas appliances firing including the CHALLENGER and a maximum pressure of 13" w.c [32 mbar] during non-flow conditions with all gas appliances off including the CHALLENGER.

Combustion Test and Adjustments

- The installer must perform a complete combustion check to ensure the following combustion levels are met at high and low input firing rates and the burner is operating at optimum conditions for propane gas.

WARNING

The combustion testing and adjustments must be performed only by a qualified installer, service agency or the gas supplier. All combustion measurements must be performed with calibrated equipment to ensure proper readings and accuracy.

CHALLENGER

Natural Gas to Propane Instructions

Table 2: Recommended Combustion Levels

Combustion Levels		Natural Gas	Propane Gas
High Fire DOOR OFF*	CO ₂ Range	9% to 10.1%	10.5% to 11.1%
	CO ₂ Target	9.0%	10.8%
	O ₂ Range	3.0% - 5.0%	4.1% - 5.0%
	O ₂ Target	5.0%	4.5%
Low Fire	CO ₂ Range	0% - 0.4% < H.F 9.0% min.	0% - 0.4% < H.F 10.5% min.
	O ₂ Range	0% - 0.6% > H.F 5.0% max.	0% - 0.6% > H.F 5.0% max.
	CO Max.	100 ppm	150 ppm

* Door On can raise the maximum allowable CO₂ by 0.4 or lower the minimum allowable O₂ by 0.6.



Failure to perform a complete combustion test at both high and low input rates may result in incomplete combustion and the production of carbon monoxide, which can cause severe personal injury, death or substantial property damage.

- Manually place the appliance into high fire mode by pressing both the service button “” with “+” button simultaneously on the control panel display two times.



The control panel will display a H followed by the current appliance temperature when placed into high fire test mode.



The THROTTLE SCREW on the CHALLENGER’s gas valve works opposite than the PRESTIGE. If you turn the CHALLENGER’s throttle screw clockwise you increase the input, CO₂ and CO of the appliance. EXERCISE CARE!

- If the combustion levels during high fire are outside the recommended combustion settings adjust the THROTTLE SCREW (see Figs. 3 & 4 on page 5) using a T15 Torx wrench as follows:

Counter-clockwise adjustment of the THROTTLE SCREW at High Fire:

O₂ increases and CO₂ decreases

Clockwise adjustment of the THROTTLE SCREW at High Fire:

O₂ decreases and CO₂ increases

- Once the combustion level is set and recorded at high fire, manually place the appliance into low fire mode by pressing the service button “” with “-” button simultaneously on the control display once.



The control panel will display a L followed by the current appliance temperature when placed into low fire test mode.

- If the combustion levels during low fire are not within 0.0 to 0.4% CO₂ lower than the combustion level measured at high fire, remove the offset pressure cover screw and adjust the OFFSET SCREW using a T15 Torx wrench as follows (see Figs. 3 & 4 on page 5):



The OFFSET SCREW adjustment on the CHALLENGER’S gas valve is very sensitive. A small adjustment will have a significant effect.

Counter-clockwise adjustment of the OFFSET SCREW at Low Fire:

O₂ increases and CO₂ decreases

Clockwise adjustment of the OFFSET SCREW at Low Fire:

O₂ decreases and CO₂ increases

CHALLENGER

Natural Gas to Propane Instructions

6. Confirm the combustion levels at both high fire and low fire meet the requirements listed in Table 2 on page 4.
7. Press the “+” and “-” button simultaneously to cancel high or low fire mode. Test mode will time out in approximately 10 minutes.
8. Replace offset cover screw.
9. Check the flame pattern through the inspection port on the left side of the heat exchanger. The flame should be blue and stable and should be the length of the burner.
10. Replace the front jacket panel and secure with the two Phillips head mounting screws at the control panel.
11. Return appliance back to service.

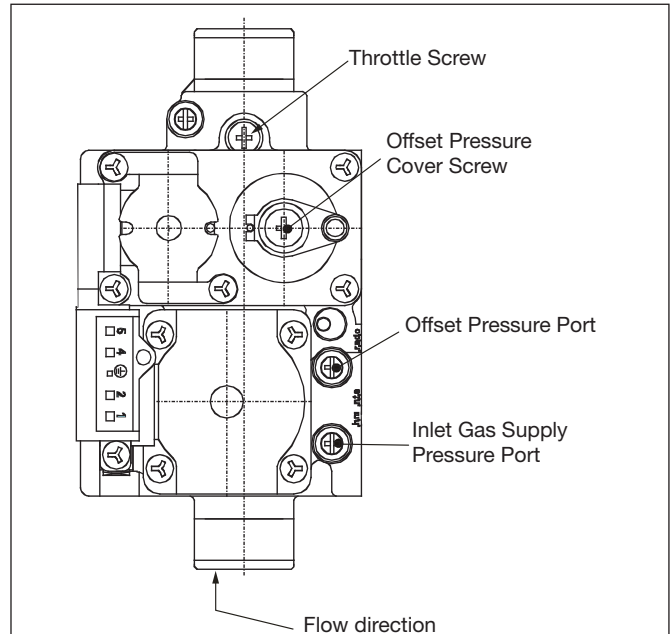

Fig. 3: Original Gas Valve

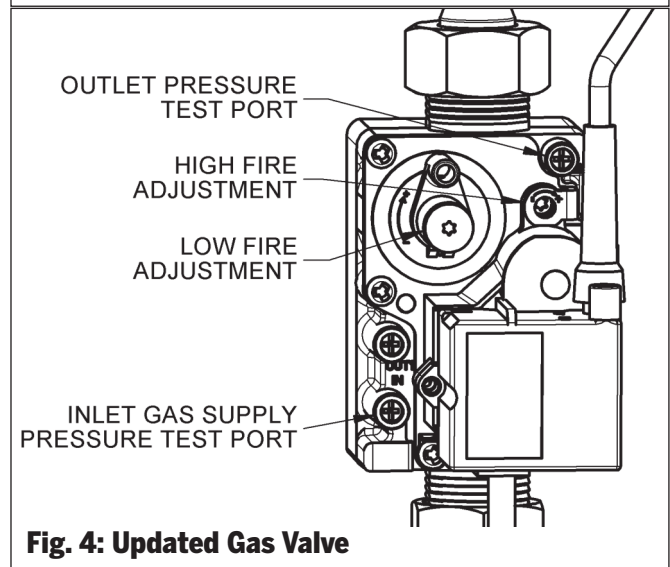

Fig. 4: Updated Gas Valve



One Triangle Lane ■ Blackwood, NJ 08012

P 856 228 8881 f 856 228 3584 W www.triangletube.com   

