



CTRLMAX SUPPLEMENT

Exalt Heat Only 110-155-199 & Combi 155-199
Exalt FSB Heat Only 110-155-199 & Combi 155-199
Gallant 250-299-399

NOTICE

- Customer must register unit within thirty (30) days of installation in order to gain warranty coverage. See Warranty Card for details.
- Leave all documentation received with appliance with the owner for future reference.

WARNING

- To maintain the safety & longevity of your appliance, read and follow the maintenance schedule information throughout this manual.
- If the information in this manual is not followed exactly, a fire or explosion may result causing substantial property damage, serious injury, or death.
- **WHAT TO DO IF YOU SMELL GAS**
 - Do not try to light any appliance
 - Do not touch any electrical switch; do not use any phone in your building.
 - Immediately call your gas supplier from a neighbor's phone. Follow the gas supplier's instructions.
 - If you cannot reach your gas supplier, call the fire department.

FOR YOUR SAFETY

- Do not store or use gasoline or other flammable vapors and liquids in the vicinity of this or any other appliance.

Installation and service must be performed by a qualified installer, service agency or the gas supplier.



INTENTIONALLY LEFT BLANK

TABLE OF CONTENTS

CHAPTER 1 - OPERATING INFORMATION	1
1.1. General.....	1
1.1.1 GALLANT Control Panel Description.....	1
1.1.2 Main settings of the GALLANT CTRLMax Display	1
1.1.3 EXALT Control Panel Description	2
1.1.4 Main settings of EXALT CTRLMax Display	3
1.1.5 Main Icons of CTRLMax display	3
1.2. Installer Access Code	3
1.3. CTRLMax Installer Menu Structure	4
CHAPTER 2 - CH SETTINGS	5
2.1. Heating Operation.....	5
2.2. Demand Type	5
2.3. CH Maximum Capacity.....	6
2.4. CH Minimum Capacity.....	7
2.5. Abs. max. CH setpoint	7
2.6. CH1 max. setpoint	7
2.7. CH1 min. setpoint.....	7
2.8. Outd. Curve Coldest Day	8
2.9. Outd. Curve Warmest Day.....	8
2.10. CH2 circuit.....	8
2.11. CH2 max. setpoint	8
2.12. CH2 min. setpoint	9
2.13. Warm Weather Shutdown	9
2.14. Circulation Pump Permanent.....	9
2.15. CH Post Pump Time.....	9
2.16. Freeze Protection	10
2.17. Frost Protection Setpoint	10
2.18. Parallel Shift Value	11
2.19. CH Call Blocking.....	11
2.20. Appliance Min CH Setpoint	11
CHAPTER 3 - DHW SETTINGS (GALLANT AND EXALT HEAT ONLY).....	13
3.1. DHW Operation	13
3.2. Demand Type	13
3.3. DHW Maximum Capacity	14
3.4. DHW Boiler Setpoint.....	14
3.5. DHW Setpoint.....	14
3.6. DHW on Differential	14

TABLE OF CONTENTS

3.7.	DHW Storage Adder	15
3.8.	DHW Post Pump Time	15
3.9.	DHW Priority Timeout	15
3.10.	DHW Priority.....	15
3.11.	DHW Call Blocking	16
3.12.	DHW to CH Call Blocking.....	16
3.13.	Antilegionella Function	17
3.14.	DHW Ramp Up	17
CHAPTER 4 - DHW SETTINGS (EXALT COMBI ONLY).....		19
4.1.	DHW Operation	19
4.2.	DHW Maximum Capacity	19
4.3.	DHW Temp.....	19
4.4.	DHW On Differential.....	20
4.5.	DHW Warmstart Temperature.....	20
4.6.	DHW Warmstart Hysteresis.....	20
4.7.	DHW Post Pump Time	20
4.8.	DHW Priority Timeout	21
4.9.	DHW Call Blocking	21
4.10.	DHW to CH Call Blocking.....	21
4.11.	DHW Ramp Up	21
CHAPTER 5 - BOILER SETTINGS.....		23
5.1.	Model	23
5.2.	Lockout Temp.....	23
5.3.	Modbus Address	23
5.4.	Pump Settings.....	24
5.4.1	Preset Pump Config	24
5.4.2	Flexible Pump Config	24
5.4.3	Error Relay.....	26
5.5.	Ignition Level.....	26
5.6.	Mix zone high limit.....	27
5.7.	WP Diff Trigger	27
5.8.	Appliance Setting.....	27
5.9.	Altitude.....	28
5.10.	EXALT Heat Only Boilers - Pump Setting Process using the Flexible Pump Config Function	40

TABLE OF CONTENTS

CHAPTER 6 - MANUAL OPERATION	51
CHAPTER 7 - RESET ALL SETTINGS.....	53
7.1. Factory CTRLMax Settings	53
CHAPTER 8 - CASCADE.....	55
8.1. Operating Principles of an CTRLMax-Controlled Cascade (GALLANT and EXALT Heat Only only).....	55
8.2. Cascade Algorithm	55
8.2.1 Boiler Enabling Algorithm	55
8.2.2 Boiler Disabling Algorithm	55
8.3. CTRLMax Cascade menu structure	56
8.4. Cascade Installation	56
8.4.1 System Piping	56
8.4.2 System Sensor Installation.....	56
8.4.3 Cascade Communication Cable.....	57
8.4.4 Low Voltage Wiring Connections	57
8.4.5 Line Voltage Wiring Connections	58
8.4.6 Cascade Autodetection	58
8.4.7 Lockouts.....	58
8.5. Cascade Autodetection	59
8.6. Cascade Info.....	60
8.6.1 Cascade Role	60
8.6.2 System Temp.	60
8.6.3 Active Boilers	60
8.6.4 Total Boilers	60
8.6.5 Cascade Firing Ratio	60
8.7. Cascade Settings	61
8.7.1 Stage Delay	61
8.7.2 Min. Firing Rate	62
8.7.3 Max. Firing Rate	62
8.7.4 CH / DHW Boilers.....	62
8.7.5 Auto Rotation	64
8.7.6 CH Prop. Gain.....	64
8.7.7 CH Integral Gain.....	65
8.7.8 DHW Prop. Gain	66
8.7.9 DHW Integral Gain	67
CHAPTER 9 - MODBUS INTERFACE.....	75

TABLE OF ILLUSTRATIONS

Fig. 1 - GALLANT Control Panel.....	1
Fig. 2 - EXALT Control Panel.....	2
Fig. 3 - System Piping with Preset Config. 1.....	29
Fig. 4 - System Piping with Preset Config. 2.....	30
Fig. 5 - System Piping with Preset Config. 3.....	31
Fig. 6 - System Piping with Preset Config. 4.....	32
Fig. 7 - System Piping with Preset Config. 5.....	33
Fig. 8 - System Piping with Preset Config. 6.....	34
Fig. 9 - System Piping with Preset Config. 7.....	35
Fig. 10 - System Piping with Preset Config. 8.....	36
Fig. 11 - System Piping with Preset Config. 9.....	37
Fig. 12 - EXALT Heat Only System Piping - Multi Zone System with Single System/Boiler Circulator.....	38
Fig. 13 - EXALT Heat Only System Piping - Indirect Water Heater installation.....	39
Fig. 14 - EXALT Heat Only System Piping - System with Two Heating Circuits, an Indirect Water Heater and Three Pumps.....	41
Fig. 15 - EXALT Heat Only System Piping - System with Two Heating Circuits, an Indirect Water Heater and Two Pumps.....	42
Fig. 16 - EXALT Heat Only System Piping - System with One Heating Circuits, an Indirect Water Heater and Three Pumps.....	43
Fig. 17 - EXALT Heat Only System Piping - System with Two Heating Circuits, and Two CH Pumps.....	44
Fig. 18 - EXALT Heat Only System Piping - System with Two Heating Circuits, and Three Pumps ..	45
Fig. 19 - EXALT Combi System Piping - Zoning w Valves.....	46
Fig. 20 - EXALT Combi - System Piping - Multi Zone Valve - Single Circulator.....	47
Fig. 21 - EXALT Combi - System Piping - Single Zone with Single Circulator.....	48
Fig. 22 - EXALT Combi System Piping - Single Zone System with Single System/Boiler Circulator...	49
Fig. 23 - EXALT Combi System Piping - Domestic piping - Storage tank installation.....	50
Fig. 24 - System Sensor Direct Immersion.....	57
Fig. 25 - System Sensor Dry well Installation.....	57
Fig. 26 - Lockouts in a cascade.....	58
Fig. 27 - Primary Secondary Cascade Piping - GALLANT only.....	67
Fig. 28 - Primary Secondary Cascade Wiring - GALLANT Only.....	68
Fig. 29 - Split Cascade System - GALLANT Only.....	69
Fig. 30 - Split Cascade Wiring - GALLANT Only.....	70
Fig. 31 - Reverse Return Cascade Piping - GALLANT.....	71
Fig. 32 - Reverse Return Cascade Wiring - GALLANT.....	72
Fig. 33 - Reverse Return Cascade Piping - EXALT Heat Only.....	73
Fig. 34 - Reverse Return Cascade Wiring - EXALT Heat Only.....	74

PRODUCT AND SAFETY INFORMATION

IMPORTANT SAFETY INFORMATION

Ideal Heating North America accepts no liability for any damage, injury, or loss of life resulting from incorrect installation, alteration of any factory supplied parts, or the use of parts or fittings not specified by Ideal. If there is a conflict or doubt about the proper installation of the unit or any factory supplied replacement parts please contact Ideal Technical Support.

DEFINITIONS

The following terms are used throughout this manual to bring attention to the presence of potential hazards or to important information concerning the product.

DANGER

Indicates the presence of a hazardous situation which, if ignored, will result in substantial property damage, serious injury, or death.

WARNING

Indicates a potentially hazardous situation which, if ignored, can result in substantial property damage, serious injury, or death.

CAUTION

Indicates a potentially hazardous situation which, if ignored, can result in minor property damage, or injury.

NOTICE

Indicates special instructions on installation, operation or maintenance, which are important to the equipment but not related to personal injury hazards.

BEST PRACTICE

Indicates recommendations made by Ideal for the installers, which will help to ensure optimum operation and longevity of the equipment.

WARNING

This document is intended to be used by a factory trained and qualified heating contractor or service technician only. Read all instructions within this document and within the relevant Boiler Installation and Maintenance Manual before proceeding. It is recommended to follow the procedures in the steps given. Skipping or missing procedural steps could result in substantial property damage, serious injury, or death.

INTENTIONALLY LEFT BLANK

1.1. General

The ControlMax (CTRLMax) system control is designed to be flexible yet easy to use. It monitors and controls the boiler to operate as efficiently as possible. CTRLMax monitors the appliance supply, return and flue gas temperatures and operates the ignitor, gas valve and blower. It uses this information to modulate the appliance firing rate to maintain the required setpoint. CTRLMax offers many advanced control options, which may be adjusted for various applications to achieve optimum appliance efficiency and operation:

- Two central / space heating (CH) call inputs with separate outdoor curves.
- A Domestic Hot Water (DHW) call input with optional priority.
- System temperature sensing and control with an optional system temperature sensor.
- A cascade function (GALLANT and EXALT Heat Only appliances only). It allows, for example, up to six boilers to operate together in a single heating system.
- A Modbus interface for integrating with building management systems.

Accessing the functions is done through the user interface, that presents itself in two different versions:

1.1.1 GALLANT Control Panel Description

1. **CTRLMax LCD Display** - It is the setup interface of the appliance and indicates the parameter values, the error codes and the set-up status of the parameters. It displays a series of screens, each showing information and/or icons.

2. **Installer button** - Allows the installer to open the access code window of the CTRLMax controller and set up the system once the code has been entered.
3. **Arrow keys and OK key** - To browse through the screens of the CTRLMax controller, set up the appliance, increase and decrease the displayed values and validate the selections. The OK key is also used to RESET the appliance after a blocking (following the instructions on the screen).

1.1.2 Main settings of the GALLANT CTRLMax Display

Screen backlight - it will illuminate when any key is depressed, and remain illuminated for five minutes.

Screen contrast - it can be adjusted at the Home screen by pressing and holding the **OK** key, then pressing and holding the **LEFT** key along with the **OK** key. Press the **UP** and **DOWN** key to increase or decrease the contrast while holding the **OK** and **LEFT** keys depressed. All keys must be released and the procedure performed again to switch between increasing and decreasing contrast.

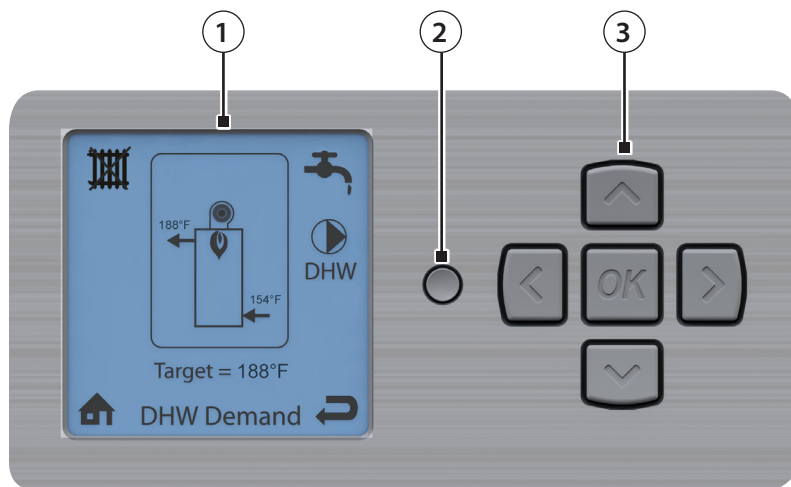

Fig. 1 - GALLANT Control Panel

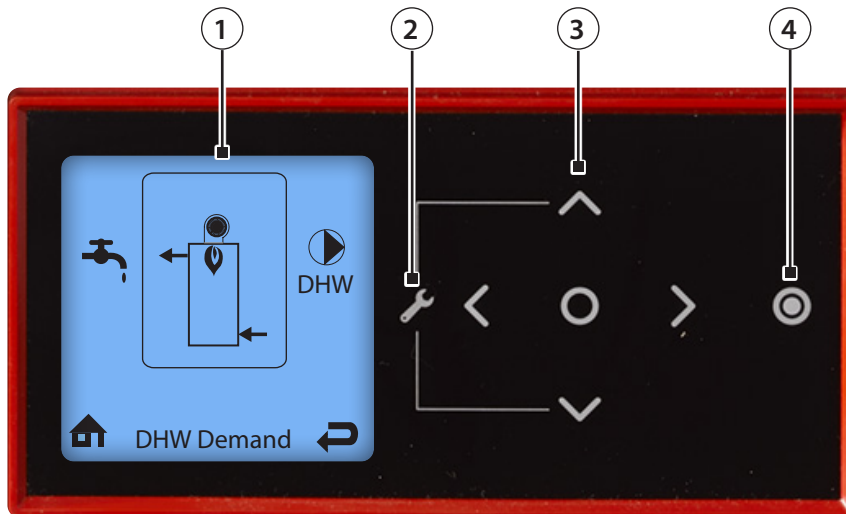



Fig. 2 - EXALT Control Panel



1.1.3 EXALT Control Panel Description

1. **CTRLMax LCD Display** - It is the setup interface of the appliance and indicates the parameter values, the error codes and the set-up status of the parameters. It displays a series of screens, each showing information and/or icons.
2. **Installer function** - By touching simultaneously the up and down arrow keys for 3 seconds, the installer can open the access code window of the CTRLMax controller and set up the system once the code has been filled in.
3. **Arrow soft keys and OK/Reset key** - To browse through the screens and menus of the CTRLMax controller, set up the appliance, increase and decrease the displayed values and validate the selections. The OK/Reset key is also used to RESET the appliance after a blocking (following the instructions on the screen).
4. **On-Off soft key** - To shut down the unit.



When touching the  soft key, the unit shuts down but is not isolated from power supply. Therefore, live current is still present in the unit. For your safety, disconnect electrical power supply to the unit before servicing or making any electrical connections to avoid possible electric shock hazard. Failure to do so can cause serious injury, or death.





NOTICE



- When shutting down using the  soft key, the appliance will not react to any heat demand. However, the basic appliance protection functions (such as frost protection, etc.) remain active.
- In addition, the arrow soft keys are no longer illuminated, and the  soft key lighting is dimmed.

The CTRLMax navigation is performed through soft keys that react to the touch and emit a short beep when tapped.

NOTICE

Exert a light and short touch (tap) on the soft keys to activate their function. Holding the touch too long will not generate any reaction from the CTRLMax, unless it is a combination of soft keys meant to be touched simultaneously for a determined duration, as instructed in this manual. The arrow keys can also be held longer to increase or decrease values faster.

Navigation through the menus and selection of items/ modification of values is performed through four arrow soft keys    . The center soft key  is used for validation (and for Reset in some cases).

The installer is provided with full access to all available features after simultaneously touching the  and  soft keys for 3 seconds and entering a code.



The Main Menu (EZSetup, no code required) can be accessed from the Home Screen by touching the center soft key . More information can be found in the Installation manual of the EXALT units.

To shut down the unit, touch the  soft key.

DANGER





When touching the  soft key, the unit shuts down but is not isolated from power supply. Therefore, live current is still present in the unit. For your safety, disconnect electrical power supply to the unit before servicing or making any electrical connections to avoid possible electric shock hazard. Failure to do so can cause serious injury, or death.

NOTICE







- *When shutting down using the  soft key, the appliance will not react to any heat demand. However, the basic appliance protection functions (such as frost protection, etc.) remain active.*
- *In addition, the arrow soft keys are no longer illuminated, and the  soft key lighting is dimmed.*

1.1.4 Main settings of EXALT CTRLMax Display

The Home Screen presents status information in a very user friendly way so that the current state of the boiler can be quickly accessed.

- **Screen backlight** - it will illuminate when any soft key is touched, and remain illuminated for five minutes.
- **Screen brightness** - it can be adjusted at the Home screen by touching and holding simultaneously the  and  soft keys for 2 seconds. Touch the  and  soft key to increase or decrease the contrast. Touch  to end the process.

1.1.5 Main Icons of CTRLMax display

-  **Central Heating** - indicates information related to the CH circuit.
-  **DHW** - indicates information related to the Domestic Hot Water circuit.
-  **Home** - to go back to the main menu screen.
-  **Back** - to go back to the previous screen.
-  **Pump** - indicates a pump is operating.
-  **Warm weather shutdown** - displays on the home screen when the outdoor temperature reaches the Warm Weather Shutdown preset temperature.

1.2. Installer Access Code

By pushing the installer button (GALLANT), or touching simultaneously the  and  soft keys for 3 seconds (EXALT), the access code window opens, where the installer can enter the specific code "054". Subsequently, the installer can access various setup screens and menus, allowing to define a large set of parameters and adapt the operation of the CTRLMax to the system configuration.

To navigate on the screen, use the **UP, DOWN, LEFT** and **RIGHT** keys, then the **OK** key to validate a selection. To increase/decrease values, use the **UP** and **DOWN** or **LEFT** and **RIGHT** keys, according to the situation and validate with **OK**.

NOTICE

Entering the installer access code allows the installer to make adjustments for 30 minutes. After 30 minutes, the access code will need to be entered again to make any adjustments.

If the end user misuses the installer code to access installer-specific parameters and makes changes that cause a system failure, any warranty claim will be void.

1.3. CTRLMax Installer Menu Structure

The Installer Menu is divided into four sections

CH & DHW Settings – Allows the installer to adjust the appliances central/space heating and domestic hot water settings for the application.

Manual Operation – The burner and circulators can be manually enabled for testing.

Cascade – Allows the installer to setup, adjust and monitor the Cascade System.

Reset All Settings – Resets all CH, DHW, and Cascade Settings back to the default settings

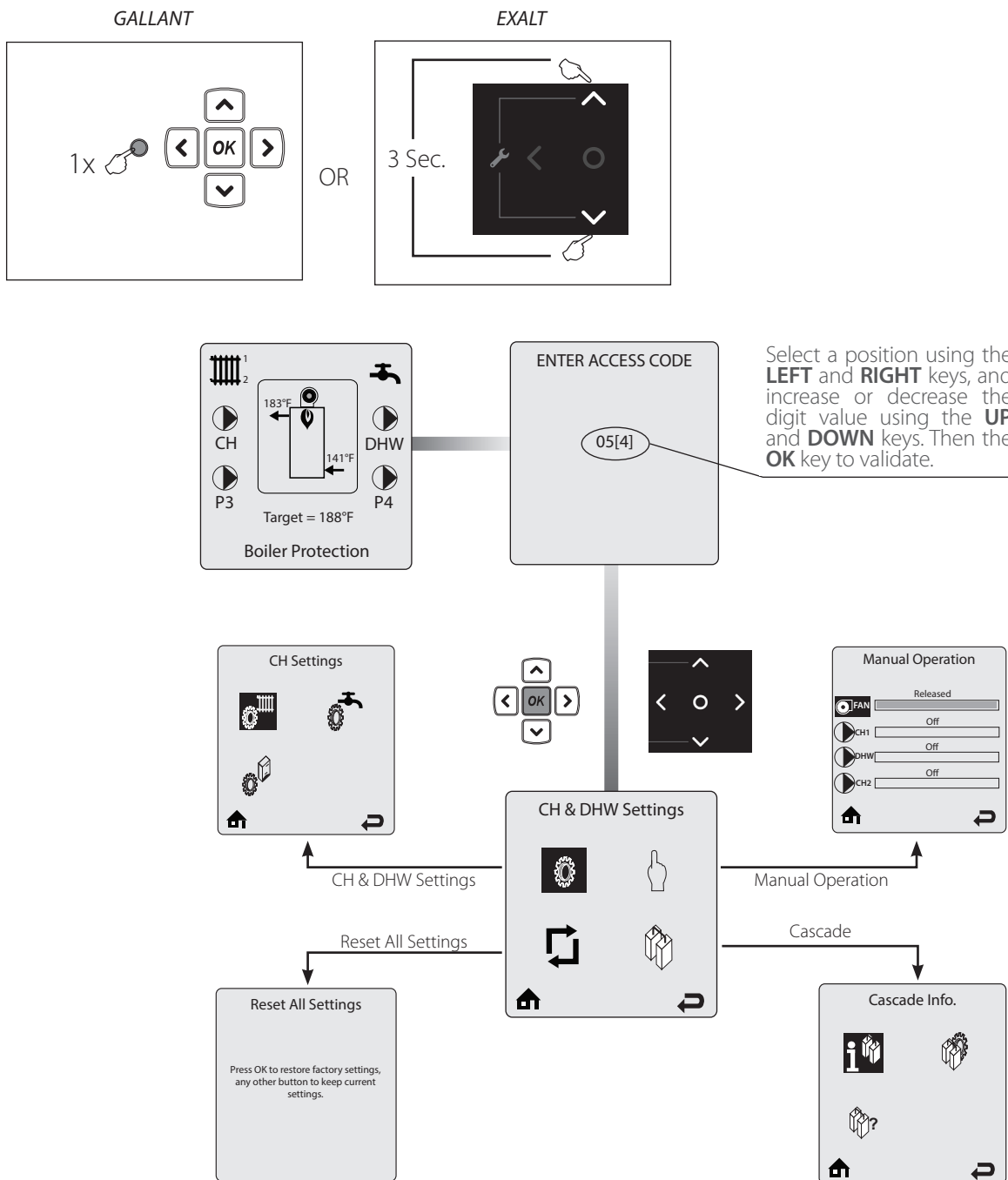

Installer Code

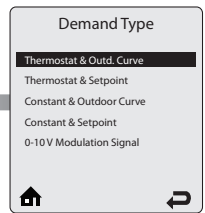
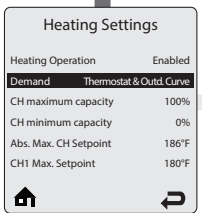
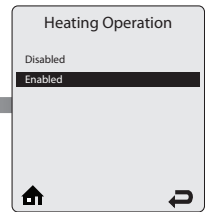
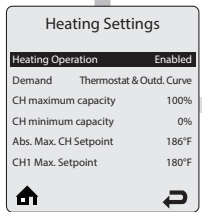
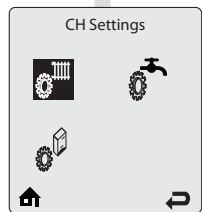
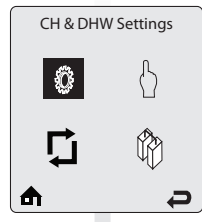

NOTICE

Navigate on the screen using the UP, DOWN, LEFT and RIGHT keys, then the validate a selection with the OK key. To increase/decrease values, use the UP and DOWN or LEFT and RIGHT keys, according to the situation and validate with OK.

Heating Operation allows the central heating function to be enabled and disabled.

Select *Enabled* or *Disabled* using the **UP** or **DOWN** keys, then store the setting with the **OK** key.

Enabled - The Appliance will respond to a central heating call.

Disabled - The Appliance will not respond to a central heating call. The heating operation disabled icon () is displayed on the home screen when central heating operation has been disabled.

NOTICE

When heating is disabled the frost protection will still be active.

Default: Enabled

Demand Type allows the installer to select how a CH Demand is generated.

Select the CH Demand Type using the **UP** or **DOWN** keys, then store the setting with the **OK** key.

Default: Thermostat and Outd. Curve

See detail of menu on next page.

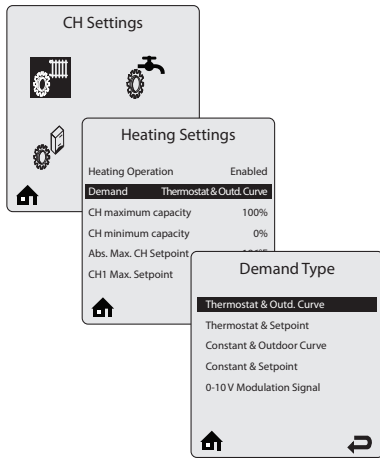

Demand Type screen menu

Thermostat & Outdoor Curve – A central heating call from a dry contact switch will enable the appliance and the setpoint will vary with the outdoor temperature for central heating calls.

Thermostat & Setpoint - A central heating call from a dry contact switch will enable the appliance and the setpoint will be fixed for central heating calls.

Constant & Outd. Curve - The appliance will maintain setpoint and the central heating circulators will be constantly enabled without an external call from a dry contact switch. The central heating circulators will be disabled when the outdoor temperature exceeds the Warm Weather Shutdown Temperature setting. The setpoint will vary with the outdoor temperature for central heating calls.

Constant & Setpoint - The appliance will maintain setpoint and the central heating circulators will be constantly enabled without an external call from a dry contact switch. The central heating circulators will be disabled when the outdoor temperature exceeds the Warm Weather Shutdown Temperature setting. The setpoint will be fixed for central heating calls.

0 - 10V Modulation Signal - This option allows the appliance firing rate to be controlled by an external control system with a 0-10 VDC signal. Based on the control input voltage, the appliance will start to operate for heat demand. The CH temperature is limited by the Absolute maximum temperature.

- 0 – 2V appliance is off.
- 2 – 10V linear power increase from minimum to maximum output.
- 10 – 2V linear power decrease from maximum to minimum output.
- 2 – 1V appliance on minimum capacity.
- 1 - 0V appliance off.

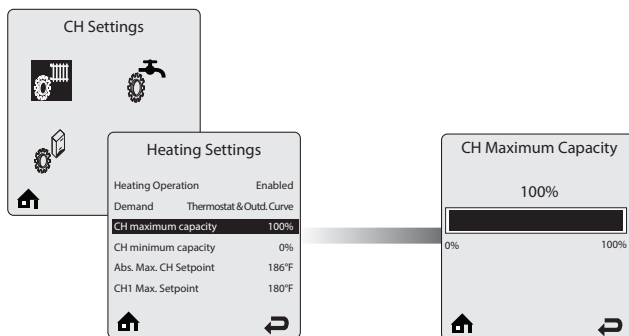

CH Maximum Capacity limits the maximum CH capacity. The appliance capacity can be defined by adjusting this value, 100% means Maximum CH output, 0% means minimum CH output. It is therefore possible to adjust the CH capacity to the installation needs.

Example: when set to 60%, the real appliance capacity is the appliance minimum capacity plus 60% of the difference between the maximum and minimum capacity.

Adjust the CH Maximum Capacity value using the **LEFT** or **RIGHT** keys to then store the setting with the **OK** key.

Default: 100%

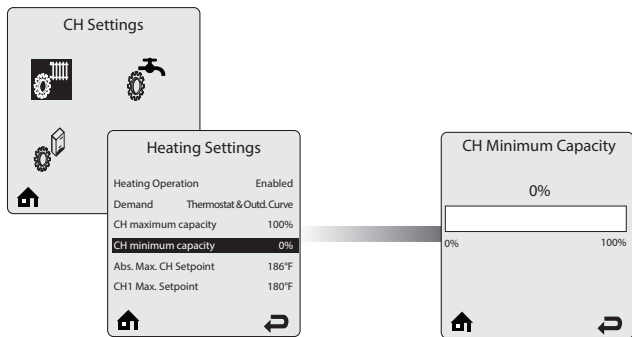

CH Minimum Capacity sets the lowest limit of the CH capacity. The appliance capacity can be defined by adjusting this value and the CH Maximum capacity. It is therefore possible to adjust the CH capacity to the installation needs.

Example: when the CH minimum capacity is set to 20%, the real appliance capacity is the appliance minimum capacity plus 20% of the difference between the maximum and minimum capacity.

Adjust the CH Minimum Capacity using the **LEFT** or **RIGHT** keys, then store the setting with the **OK** key.

Default: 0%

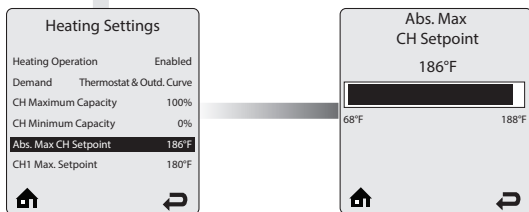

Absolute Max CH Setpoint limits the setpoint during a central heating call. This setting can be used to prevent a user from adjusting the central heating setpoint or outdoor curve above a safe operating temperature in the EZ Setup Menu. A warning screen will be displayed in EZ Setup if the user attempts to raise the setpoint above the Absolute Max CH Setpoint. The Absolute Max CH Setpoint will be displayed on the outdoor curve in EZ Setup if the user selects an outdoor curve which goes above the Absolute Max CH Setpoint.

Adjust the Absolute Max CH Setpoint using the **LEFT** or **RIGHT** keys to then store the setting with the **OK** key.

Default: 186°F

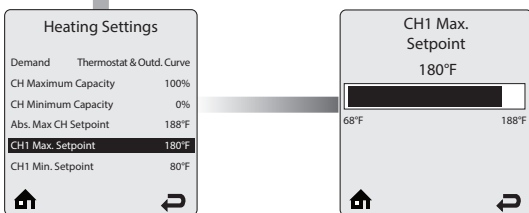

CH1 Max. Setpoint is the maximum setpoint for a CH1 heating call when an Outdoor Curve option is chosen in Demand Type. CH1 Maximum Setpoint is the fixed setpoint for a CH1 heating call when a Setpoint option is chosen in Demand Type.

Adjust the CH1 Maximum Setpoint value using the **LEFT** or **RIGHT** keys, then store the setting with the **OK** key.

Default: 180°F

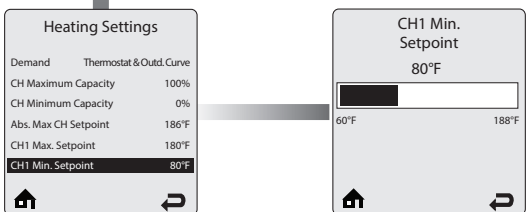

CH1 Min. Setpoint is the minimum setpoint for a CH1 heating call when an Outdoor Curve option is chosen in Demand Type. This setting is not applicable when a Setpoint option is chosen in Demand Type.

CH1 Min. Setpoint must be set equal or below the CH1 max. setpoint.

Adjust the CH1 Minimum Setpoint value using the **LEFT** or **RIGHT** keys, then store the setting with the **OK** key.

Default: 80°F

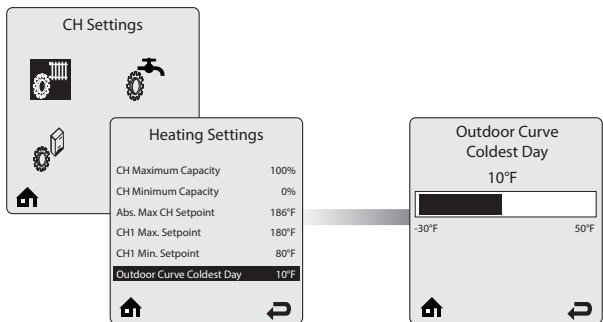

Outdoor Curve Coldest Day is the coldest outdoor design temperature of the heating system when an Outdoor Curve option is chosen in Demand Type. This setting is not applicable when a Setpoint option is chosen in Demand Type.

Adjust the Outdoor Curve Coldest Day value using the **LEFT** or **RIGHT** keys, then store the setting with the **OK** key.

Default: 10°F

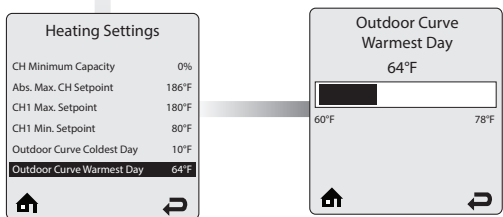

Outdoor Curve Warmest Day is the warmest outdoor design temperature of the heating system when an Outdoor Curve option is chosen in Demand Type. This setting is not applicable when a Setpoint option is chosen in Demand Type.

Adjust the Outdoor Curve Warmest Day value using the **LEFT** or **RIGHT** keys, then store the setting with the **OK** key.

Default: 64°F

NOTICE

The temperatures of Outdoor Curve Coldest Day and Outdoor Curve Warmest Day are identical to those of CH1 and CH2.

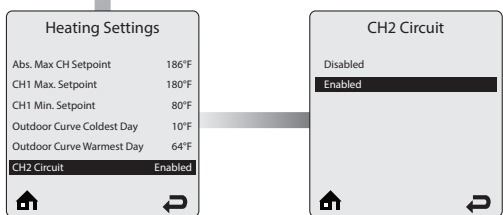

CH2 Circuit allows the CH2 Max and Min setpoints to be enabled and disabled. When disabled, the boiler will not respond to a CH2 heating call.

Select *Enabled* or *Disabled* using the **UP** or **DOWN** keys, then store the setting with the **OK** key.

Enabled – The appliance will respond to a CH2 heating call using CH2 max and min setpoints.

Disabled – The appliance will not respond to a CH2 heating call using CH2 max and min setpoints.

Default: Enabled

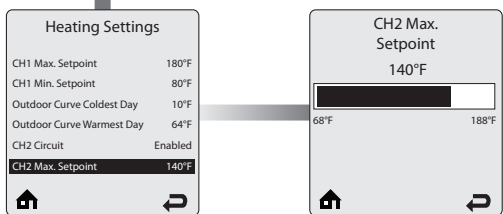

CH2 Maximum Setpoint is the maximum setpoint for a CH2 heating call when an Outdoor Curve option is chosen in Demand Type. CH2 Maximum Setpoint is the fixed setpoint for a CH2 heating call when a Setpoint option is chosen in Demand Type.

Adjust the CH2 Maximum Setpoint value using the **LEFT** or **RIGHT** keys, then store the setting with the **OK** key.

Default: 140°F

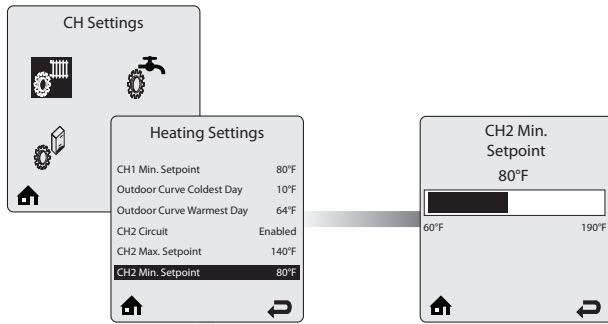

CH2 Minimum Setpoint is the minimum setpoint for a CH2 heating call when an Outdoor Curve option is chosen in Demand Type. This setting is not applicable when a Setpoint option is chosen in Demand Type.

Adjust the CH2 Minimum Setpoint value using the **LEFT** or **RIGHT** keys, then store the setting with the **OK** key.

Default: 80°F

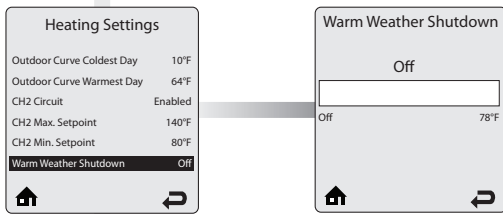

Warm Weather Shutdown allows to enter an optional outdoor temperature at which to disable the central heating function. The Appliance will continue to respond to a domestic hot water call or a 0- 10V Modulation Signal when the outdoor temperature exceeds the Warm Weather Shutdown Temperature setting.

Adjust the Warm Weather Shutdown Temperature value using the **LEFT** or **RIGHT** keys, then store the setting with the **OK** key.

The Warm Weather Shutdown icon  is displayed on the home screen when the outdoor temperature reaches the Warm Weather Shutdown Temperature.

Default: OFF.

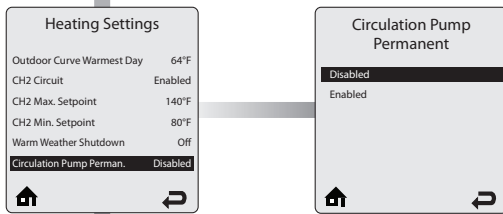

Circulation Pump Permanent allows the central heating circulators to be constantly enabled even without a central heating call. A domestic hot water call will cause the circulators to be disabled during the domestic call as long as DHW Priority is enabled.

Select *Enabled* or *Disabled* using the **UP** or **DOWN** keys, then store the setting with the **OK** key.

- **Enabled** – The central heating circulators will be enabled for constant circulation without a central heating call.
- **Disabled** – The central heating circulators will only be enabled during a central heating call.

Default: Disabled

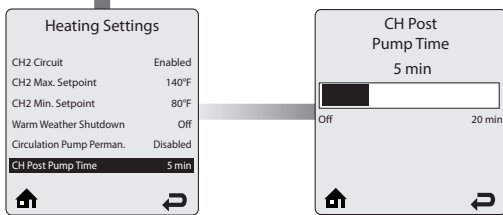

CH Post Pump Time sets how long the central heating circulators will continue to operate at the completion of a heating call. Any call during the CH Post Pump Time will be ignored until the post pump has completed. The CH Post Pump Time feature allows the heat remaining in the appliance at the completion of a call to be sent to the heating system, which will improve the overall efficiency of the system.

Adjust the CH Post Pump Time value using the **LEFT** or **RIGHT** keys, then store the setting with the **OK** key.

Default: 5 min

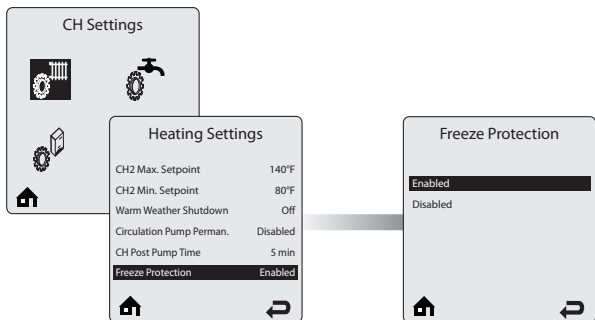

The **Freeze Protection** menu allows the feature to be enabled and disabled. The built-in frost protection mechanism activates the system pumps as soon as the flow temperature [NTC1 probe] drops below 46°F. As soon as the flow temperature is at 42°F, the burner starts up until the flow temperature rises above 60°F. The pumps continue to run for around 10 minutes.

Select *Enabled* or *Disabled* using the **UP** or **DOWN** keys, then store the setting with the **OK** key.

- **Enabled** – The Freeze Protection feature protects the installation from freezing at a predetermined system flow temperature.
- **Disabled** – The Freeze Protection feature is disabled. Only the pumps operate.

Default: Enabled

⚠ WARNING

The appliance should **NEVER** be installed in a location where freezing could occur. Subjecting the appliance to freezing conditions could lead to freezing of the condensate possibly causing serious injury or death.

CAUTION

Freeze Protection should only be disabled when the system contains antifreeze to prevent the system from freezing. Serious damage could occur to the appliance as well as the entire heating system if Freeze Protection is disabled without antifreeze in the system.

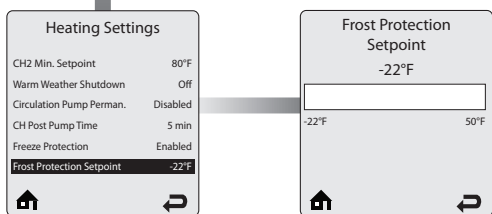

Frost Protection Setpoint allows to define the outside air temperature at which the anti-freeze function is activated (only available if an outdoor temperature sensor is connected). The pumps are activated when the outside temperature drops below the threshold defined in this menu.

Adjust the Frost Protection Setpoint using the **LEFT** or **RIGHT** keys, then store the setting with the **OK** key.

CAUTION

In order to enable the protection of the whole system against freezing, all the valves of the radiators and the convectors should be completely open.

Default: -22°F

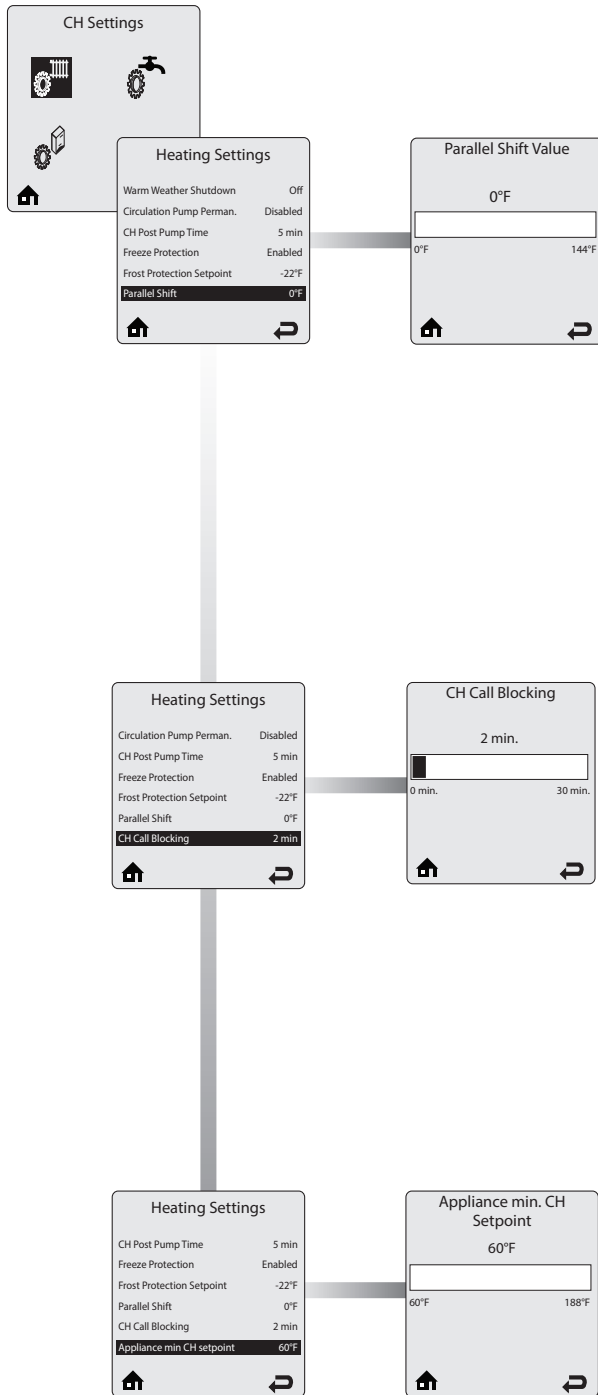

NOTICE

Although the function and the screen are displayed in Gallant units, this function is not in use. Any change made to the value will not affect the operation of the appliance

CH Call Blocking sets the minimum time between burner firings for central heating calls. At the completion of a burner firing, the CH Call Blocking time will begin. The burner will not fire again until after the CH Call Blocking time has elapsed. The CH Call Blocking time only prevents the burner from firing, the central heating circulators will respond to a central heating call. This blocking time has no affect on domestic hot water calls. The CH Call Blocking feature prevents short cycling of the burner and extends the life of the burner components.

Adjust the CH Call Blocking value using the **LEFT** or **RIGHT** keys, then store the setting with the **OK** key.

Default: 2 min.

Appliance min CH Setpoint - The minimum setpoint can be reduced when the heating system is needing it to defrost installations.

Adjust the Appliance min. CH Setpoint using the **LEFT** or **RIGHT** keys, then store the setting with the **OK** key.

Default: 60°F.

INTENTIONALLY LEFT BLANK

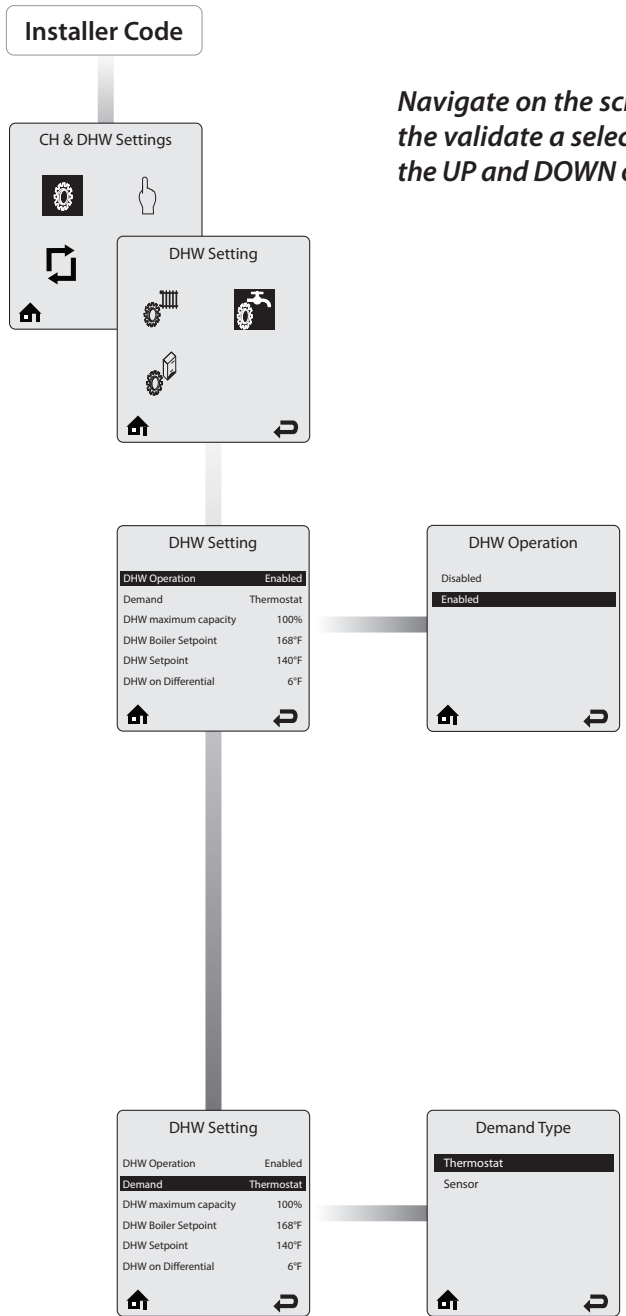

NOTICE

Navigate on the screen using the UP, DOWN, LEFT and RIGHT keys, then validate a selection with the OK key. To increase/decrease values, use the UP and DOWN or LEFT and RIGHT keys, according to the situation and validate with OK.

The **DHW Setting** menu contains settings related to domestic hot water operation. Each line contains a DHW Setting followed by its current value. Six DHW Settings are displayed on the screen at one time.

DHW Operation allows the domestic hot water function to be enabled and disabled.

Select *Enabled* or *Disabled* using the **UP** or **DOWN** keys, then store the setting with the **OK** key.

- **Enabled** - The appliance will respond to a domestic hot water call.
- **Disabled** - The appliance will not respond to a domestic hot water call. The domestic hot water operation disabled icon (🚫) is displayed on the home screen when domestic hot water operation has been disabled.

DHW Operation default: Enabled

Demand Type allows the installer to select the type of device which will generate a domestic hot water call.

Select the DHW Demand Type using the **UP** or **DOWN** keys, then store the setting with the **OK** key.

The DHW Demand options are:

- **Thermostat** - A domestic hot water call from an aquastat or dry contact switch will enable the Appliance with a fixed setpoint for a domestic hot water call.
- **Sensor** - This option requires the use of an Indirect Water Heater Sensor. The Appliance will monitor the DHW storage temperature and generate a domestic hot water call when the temperature drops below the DHW Storage Setpoint - DHW On Differential.

Default: Thermostat

CHAPTER 3 - DHW SETTINGS (GALLANT AND EXALT HEAT ONLY)

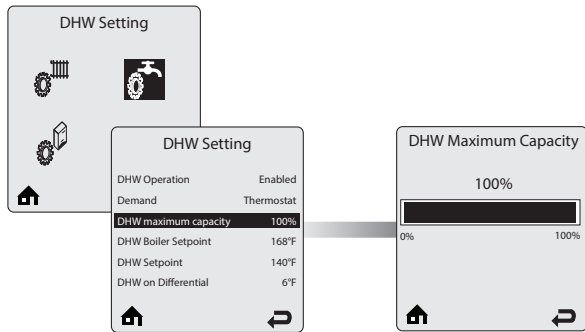

DHW Maximum Capacity limits the maximum DHW capacity. The appliance capacity can be defined by adjusting this value, 100% means Maximum DHW output, 0% means minimum DHW output. It is therefore possible to adjust the DHW capacity to the installation needs.

Example: when set to 60%, the real appliance capacity is the appliance minimum capacity plus 60% of the difference between the maximum and minimum capacity.

Adjust the DHW Maximum Capacity value using the **LEFT** or **RIGHT** keys, then store the setting with the **OK** key.

Default: 100%

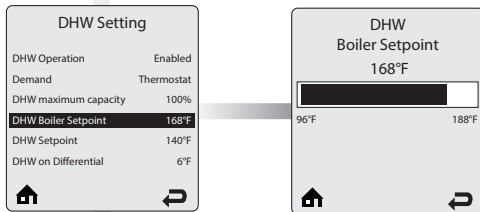

DHW Boiler Setpoint is the fixed appliance setpoint temperature during a domestic hot water call when the Thermostat option is chosen in Demand Type.

Adjust the DHW Boiler Setpoint value using the **LEFT** or **RIGHT** keys, then store the setting with the **OK** key.

Default: 168°F

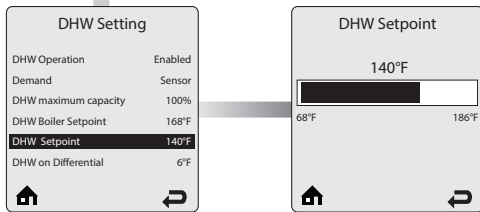

DHW Setpoint is the domestic hot water storage setpoint temperature when the Sensor option is chosen in Demand Type.

Adjust the DHW Setpoint value using the **LEFT** or **RIGHT** keys, then store the setting with the **OK** key.

Default: 140°F

NOTICE

The appliance setpoint is automatically set to the DHW Setpoint + DHW Storage adder when the Sensor option is chosen

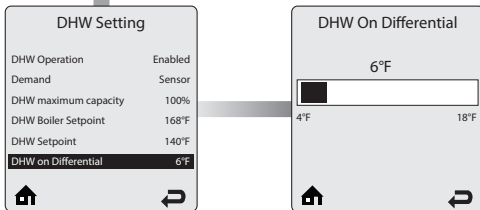

DHW On Differential sets how far the DHW storage temperature must fall below the DHW Storage Setpoint to create a domestic hot water call when the Sensor option is chosen in Demand Type. The domestic hot water call will end when the DHW storage temperature rises above the DHW Storage Setpoint.

Adjust the DHW On Differential value using the **LEFT** or **RIGHT** keys, then store the setting with the **OK** key.

Default: 6°F



WARNING

The DHW on differential setting greatly affects the production of domestic hot water. A low setting could result in a rapid response to a domestic hot water call resulting in a potential scald hazard. It is strongly recommended that the installer use a thermostatic mixing valve on the hot water outlet of the Indirect Water Heater. Failure to comply can result in substantial property damage, serious injury, or death.

CHAPTER 3 - DHW SETTINGS (GALLANT AND EXALT HEAT ONLY)

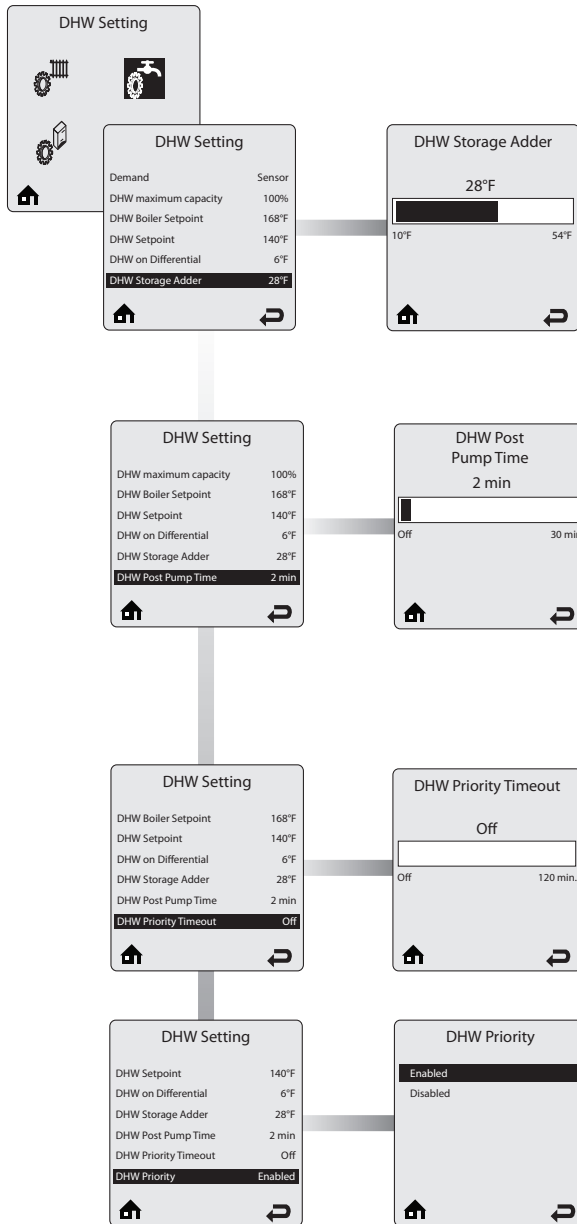

DHW Storage Adder is used to compute the appliance setpoint when the Sensor option is chosen in Demand Type. The appliance setpoint will be DHW Storage Setpoint + DHW Storage Adder for a domestic hot water call.

Adjust the DHW Storage Adder value using the **LEFT** or **RIGHT** keys, then store the setting with the **OK** key.

Default: 28°F

DHW Post Pump Time sets how long the domestic hot water circulator will continue to operate at the completion of a domestic hot water call. Any call during the DHW Post Pump Time will be ignored until the post pump has completed. The DHW Post Pump feature allows the heat remaining in the appliance at the completion of a call to be sent to the Indirect Water Heater, which will improve the overall efficiency of the system.

Adjust the DHW Post Pump value using the **LEFT** or **RIGHT** keys, then store the setting with the **OK** key.

Default : 2 min.

DHW Priority Timeout allows the installer to enter an optional time limit that a domestic hot water call has priority over a central heating call when DHW Priority is set to Enabled.

Adjust the DHW Priority Timeout value using the **LEFT** or **RIGHT** keys, then store the setting with the **OK** key.

Default: Off

DHW Priority allows the domestic hot water priority function to be enabled and disabled.

Select *Enabled* or *Disabled* using the **UP** or **DOWN** keys, then store the setting with the **OK** key.

- **Enabled** - Domestic hot water calls will have priority over a central heating call. The appliance setpoint will be set to the domestic hot water setpoint during a domestic hot water call. The DHW circulator will be enabled and the heating circulators will be disabled during a domestic hot water call.
- **Disabled** - Domestic hot water calls will not have priority over a central heating call. The appliance setpoint will be set to the domestic hot water setpoint when only a domestic hot water call is present. The appliance setpoint will be set to the highest setpoint when simultaneous domestic hot water and central heating calls are present. The DHW circulator will be enabled during a domestic hot water call. The heating circulators will be enabled during a central heating call.

Default: Enabled

NOTICE

Simultaneous domestic hot water and central heating calls will result in the appliance operating at the highest target temperature when DHW Priority is set to disabled. The use of a mixing device on the lower temperature zones may be required to protect the lower temperature zones from damage.

CHAPTER 3 - DHW SETTINGS (GALLANT AND EXALT HEAT ONLY)

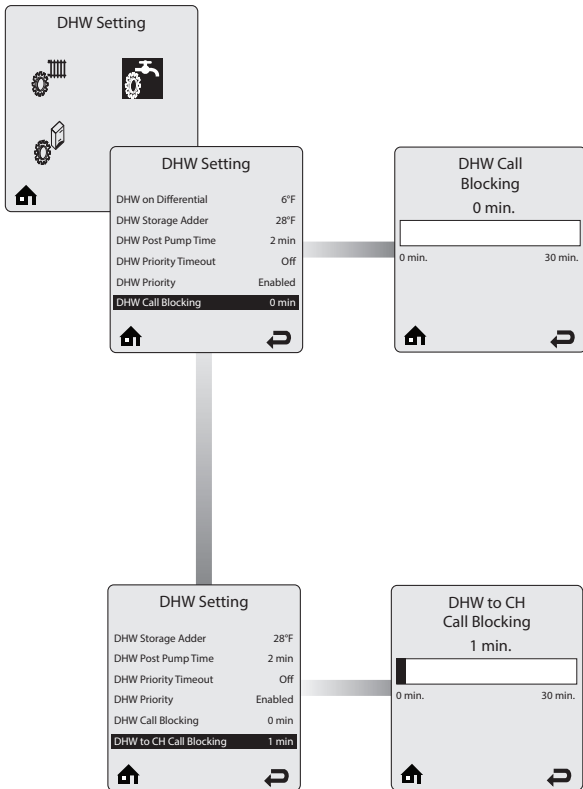

DHW Call Blocking sets the minimum time between burner firings for domestic hot water calls. At the completion of a burner firing, the DHW Call Blocking time will begin. The burner will not fire again until after the DHW Call Blocking time has elapsed. The DHW Call Blocking time only prevents the burner from firing, the domestic hot water circulator will respond to a domestic hot water call. This blocking time has no effect on central heating calls. The DHW Call Blocking feature prevents short cycling of the burner and extends the life of the burner components.

Adjust the DHW Call Blocking value using the **LEFT** or **RIGHT** keys, then store the setting with the **OK** key.

Default: 0 min.

DHW To CH Call Blocking sets the minimum time between a DHW burner firing and a CH burner firing. At the completion of a DHW burner firing, the DHW to CH Call Blocking time will begin. The burner will not fire again for a central heating call until after the DHW To CH Call Blocking time has elapsed. This feature only prevents the burner from firing, the central heating circulators will respond to a central heating call. This blocking time has no effect on domestic hot water calls. The DHW To CH Call Blocking feature prevents the burner from firing when switching from a domestic hot water call to a central heating call. This allows the remaining heat in the heat exchanger to be dissipated and potentially satisfy the central heating call.

Adjust the DHW to CH Call Blocking value using the **LEFT** or **RIGHT** keys, then store the setting with the **OK** key.

Default: 1 min.

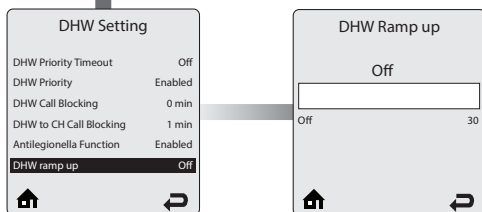
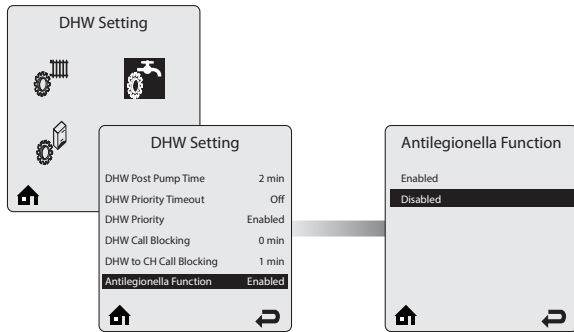

The **Antilegionella Function** ensures that an Indirect Water Heater is heated at least once per week to prevent the growth of Legionella bacteria.

Select **Enabled** or **Disabled** using the **UP** or **DOWN** keys, then store the setting with the **OK** key.

- **Enabled**- When the **Thermostat** option is chosen in Demand Type, a domestic hot water call is generated for 15 minutes once per week to heat the Indirect Water Heater.

When the **Sensor** option is chosen in Demand Type, a domestic hot water call is generated until the DHW storage temperature reaches 140°C once per week. When the Sensor option is chosen in Demand Type, the weekly timer is reset whenever the DHW storage temperature reaches 140°C to prevent unnecessary firings. This function will be active even if DHW Operation has been set to Disabled.

- **Disabled** - The Appliance will only fire in DHW mode when a domestic hot water call is received.

Default: Disabled



The antilegionella function should only be enabled when an Indirect Water Heater is installed. Enabling the antilegionella function without an Indirect Water Heater will result in the Appliance firing once per week in DHW mode. This could cause a Manual Reset Hard Lockout of the appliance.

NOTICE

The antilegionella function is most effective when the Sensor option is chosen in DHW demand. The use of an Indirect Water Heater Sensor ensures that the domestic hot water is heated to 140°F at least once a week.

The **DHW Ramp up** function limits the CH temperature rise of the CH water during the startup of the appliance in DHW mode. The parameter is expressed in °C/min.

This function is not available in Gallant units.

Adjust the DHW Ramp Up value using the **LEFT** or **RIGHT** keys, then store the setting with the **OK** key.

Default: Off

INTENTIONALLY LEFT BLANK

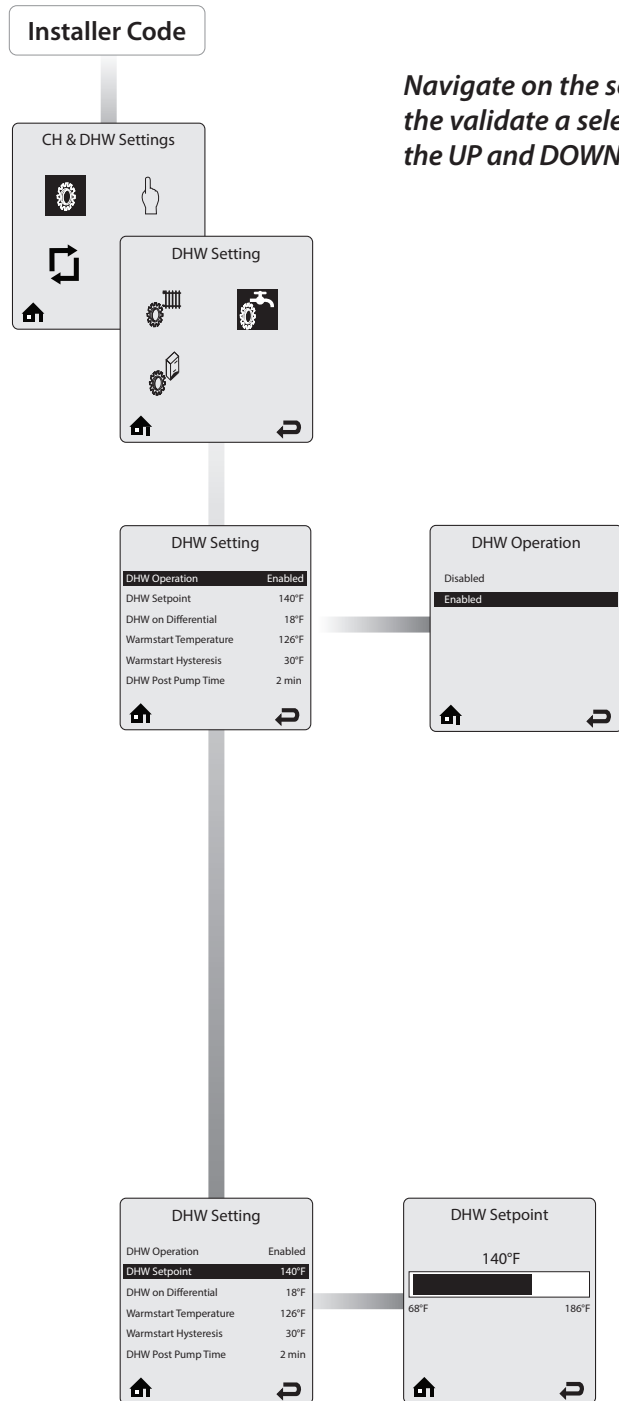

NOTICE

Navigate on the screen using the **UP**, **DOWN**, **LEFT** and **RIGHT** keys, then the validate a selection with the **OK** key. To increase/decrease values, use the **UP** and **DOWN** or **LEFT** and **RIGHT** keys, according to the situation and validate with **OK**.

The **DHW Setting** menu contains settings related to domestic hot water operation. Each line contains a DHW Setting followed by its current value. Six DHW Settings are displayed on the screen at one time.

DHW Operation prompts to enter the fixed setpoint temperature during a domestic hot water call.

Select *Enabled* or *Disabled* using the **UP** or **DOWN** keys, then store the setting with the **OK** key.

- **Enabled** - The appliance will respond to a domestic hot water call.
- **Disabled** - The appliance will not respond to a domestic hot water call. The domestic hot water operation disabled icon () is displayed on the home screen when domestic hot water operation has been disabled.

DHW Operation default: Enabled

DHW Setpoint is the fixed setpoint temperature during a domestic hot water call.

Adjust the DHW Setpoint value using the **LEFT** or **RIGHT** keys, then store the setting with the **OK** key.

Default: 140°F

CHAPTER 4 - DHW SETTINGS (EXALT COMBI ONLY)

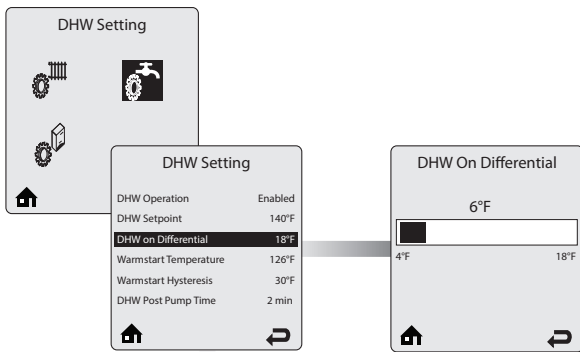

DHW On Differential sets how far the DHW temperature of the storage tank must fall below the DHW Setpoint to create a domestic hot water call. This is defined by the sensor of the external DHW storage tank connected to the appliance. The domestic hot water call will end when the DHW storage tank temperature rises above the DHW setpoint.

Adjust the DHW On Differential value using the **LEFT** or **RIGHT** keys, then store the setting with the **OK** key.

Default: 18°F

WARNING

The DHW on differential setting greatly affects the production of domestic hot water. A low setting could result in a rapid response to a domestic hot water call resulting in a potential scald hazard. It is strongly recommended that the installer use a thermostatic mixing valve on the hot water outlet of the storage tank. Failure to comply can result in substantial property damage, serious injury, or death.

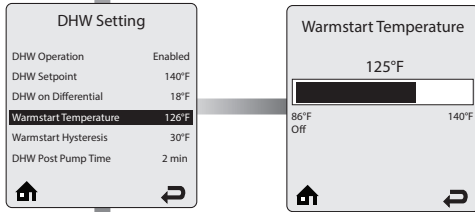

Warmstart Temperature sets the desired temperature to keep the hydroblock at, in order to speed up hot water delivery time.

Adjust the Warmstart Temperature using the **LEFT** or **RIGHT** keys, then store the setting with the **OK** key.

Default: 125°F [52°C].

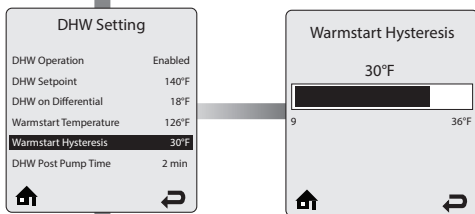

DHW Warmstart Hysteresis sets how low the internal Domestic Hot Water temperature must fall (between 9°F (5K) and 36°F (20K)) the Warmstart Temperature to activate the Warmstart function.

Adjust the DHW Warmstart Hysteresis value using the **LEFT** or **RIGHT** keys, then store the setting with the **OK** key.

Default: 30°F [17°C].

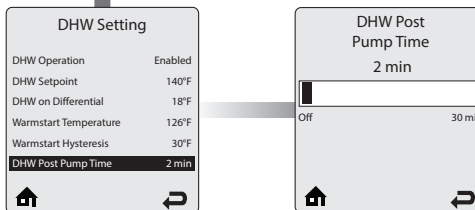

DHW Post Pump Time sets how long the domestic hot water circulator will continue to operate at the completion of a domestic hot water call. Any call during the DHW Post Pump Time will be ignored until the post pump has completed. The DHW Post Pump feature allows the heat remaining in the appliance at the completion of a call to be sent to the Indirect Water Heater, which will improve the overall efficiency of the system.

Adjust the DHW Post Pump Time value using the **LEFT** or **RIGHT** keys, then store the setting with the **OK** key.

Default : 2 min.

CHAPTER 4 - DHW SETTINGS (EXALT COMBI ONLY)

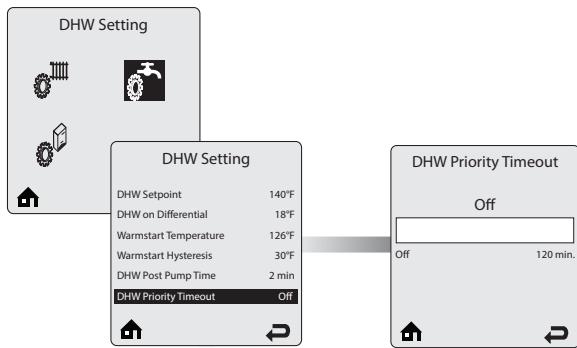

DHW Priority Timeout allows the installer to enter an optional time limit that a domestic hot water call has priority over a central heating call when DHW Priority is set to Enabled. Adjust the DHW Priority Timeout value using the **LEFT** or **RIGHT** keys, then store the setting with the **OK** key.

Default: Off

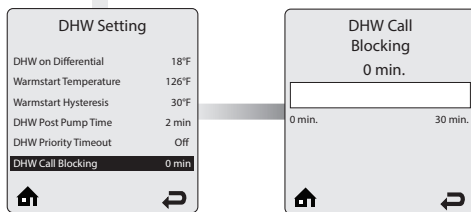

DHW Call Blocking sets the minimum time between burner firings for domestic hot water calls. At the completion of a burner firing, the DHW Call Blocking time will begin. The burner will not fire again until after the DHW Call Blocking time has elapsed. The DHW Call Blocking time only prevents the burner from firing, the domestic hot water circulator will respond to a domestic hot water call. This blocking time has no affect on central heating calls. The DHW Call Blocking feature prevents short cycling of the burner and extends the life of the burner components.

Adjust the DHW Call Blocking value using the **LEFT** or **RIGHT** keys, then store the setting with the **OK** key.

Default: 0 min.

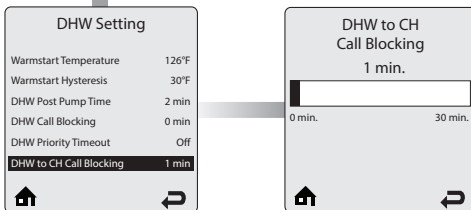

DHW To CH Call Blocking sets the minimum time between a DHW burner firing and a CH burner firing. At the completion of a DHW burner firing, the DHW to CH Call Blocking time will begin. The burner will not fire again for a central heating call until after the DHW To CH Call Blocking time has elapsed. This feature only prevents the burner from firing, the central heating circulators will respond to a central heating call. This blocking time has no effect on domestic hot water calls. The DHW To CH Call Blocking feature prevents the burner from firing when switching from a domestic hot water call to a central heating call. This allows the remaining heat in the heat exchanger to be dissipated and potentially satisfy the central heating call.

Adjust the DHW to CH Call Blocking value using the **LEFT** or **RIGHT** keys, then store the setting with the **OK** key.

Default: 1 min.

INTENTIONALLY LEFT BLANK

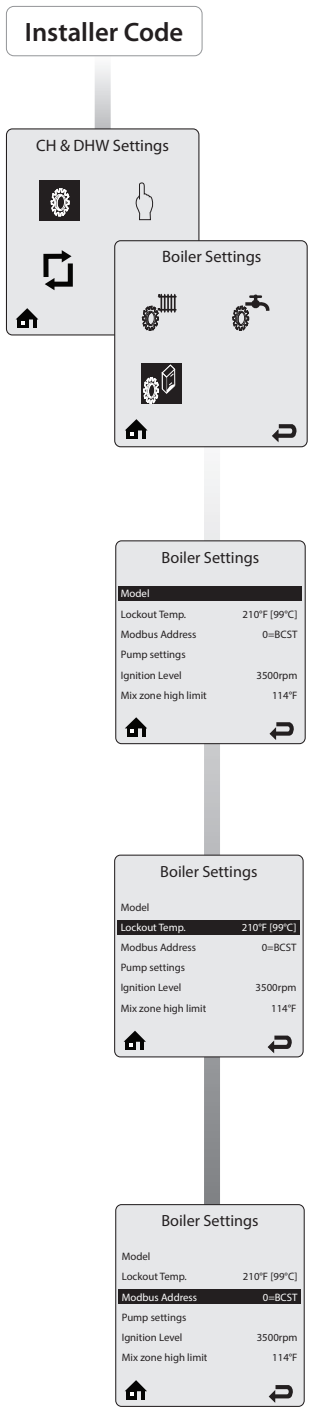

NOTICE

Navigate on the screen using the **UP**, **DOWN**, **LEFT** and **RIGHT** keys, then the validate a selection with the **OK** key. To increase/decrease values, use the **UP** and **DOWN** or **LEFT** and **RIGHT** keys, according to the situation and validate with **OK**.

The **Boiler Settings** menu contains settings related to appliance operation. Each line contains an appliance setting followed by its current value.

The **Model** menu indicates the type of appliance for which the system is set up. Gallant units are designated by "Solo", Exalt Combi by "Combi", whereas Exalt Heat Only appliances display no model designation.

The **Lockout Temp.** setting allows testing of the overheat thermostat function at a reduced temperature. It temporarily decreases the overheat temperature of the appliance to 102°F which allows a safe demonstration of the function. When setting the value to 102°F, a High temperature lockout (E3) will occur when the boiler reaches 102°F. Scroll through the settings using the **UP** or **DOWN** keys, then validate the selection with the **OK** key.
Default: 210°F

This parameter sets the **Modbus address** of the appliance in a Modbus based communication system. Adjust the Modbus Address value using the **LEFT** or **RIGHT** keys, then store the setting with the **OK** key.
Default: 0=BCST



The **Pump Settings** menu allows to choose the right pump configuration to the chosen hydraulic configuration.

The **Current Pump Config** indicates which configuration is currently selected for the appliance.

Two appliance configuration modes are available : a preset configuration mode and a flexible configuration mode.

Scroll through the settings using the **UP** or **DOWN** keys, then validate the selection with the **OK** key.

In the **Preset Pump Config.** (preferred selection) you can choose from a number of preset pump configurations. Only the configurations usable with a certain model/type of appliance will appear in the list. 16 preset configurations are available for Gallant units, and 6 for Exalt units. Some configurations are detailed through one or several hydraulic diagrams, a table indicating the electrical connections and a list of the parameters to be defined in CTRLMax. Also reference *Table 1 on page 43* for Exalt.

Scroll through the settings using the **UP** or **DOWN** keys, then validate the selection with the **OK** key.

The **Flexible Pump Config.** menu allows to customize the pump configuration to the chosen hydraulic configuration. Only select this option when the preset configurations do not offer you a solution. In this menu you have to choose per relay for which heat demand / function it will be activated. The relays are allocated as follows by default (see picture below for physical location on the optional terminal blocks) :

	Gallant	Exalt
Flex. Relay 1	CH	Boiler
Flex. Relay 2	DHW	DHW
Flex. Relay 3	P3	CH1
Flex. Relay 4	ERR	—
Flex. Relay 5	FL	CH2
Flex. Relay 6	P4	—

Scroll through the settings using the **UP** or **DOWN** keys, then validate the selection with the **OK** key.

NOTICE

- Flex Relays 4 and 6 are not available in EXALT units.

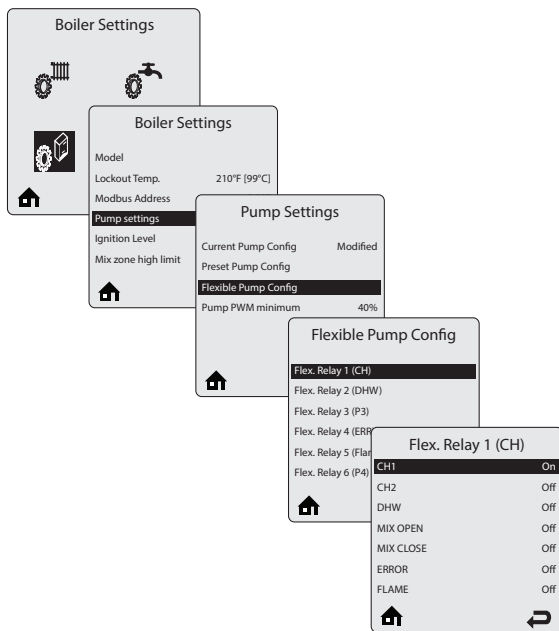

Each relay function has several options. Activation will happen when one of the following inputs has been chosen: **CH1, CH2, DHW, MIX OPEN, MIX CLOSE, ERROR, FLAME.**

More than one action can be chosen for one relay (one relay can become active for CH1, CH2 and DHW demand when needed.)

Scroll through the settings using the **UP** or **DOWN** keys, then with the **OK** key, toggle between the On/Off status of each relay. Then go to the next line, until you reach the last line.

- When selecting **CH 1**, the relay is activated at CH 1 demand.
- When selecting **CH 2**, the relay is activated at CH 2 demand.
- When selecting **DHW**, the relay is activated at DHW demand.
- When selecting **Mix Open**, the Mixing valve open input is activated. Provided there is a mixing valve in the hydraulic circuit, runtime is assumed to be 120 sec. (**available in Gallant units only**).
- When selecting **Mix Close**, the Mixing valve close input is activated. Provided there is a mixing valve in the hydraulic circuit, runtime is assumed to be 120 sec. (**available in Gallant units only**).
- When selecting **ERROR**, the relay is activated on error.
- When selecting **FLAME**, the relay is activated when appliance is running and a flame signal has been detected.

NOTICE

Using the **RIGHT** key then the **OK** key takes you back to the previous screen, but **THE CHANGED VALUES ARE NOT STORED** in the memory (Quick escape route).
 To save your changes, make sure to scroll down to the last line of the screen until **Save & Exit** is highlighted. Then activate the function with the **OK** key.

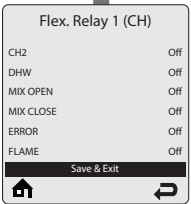

Activate **Save & Exit** with the **OK** key. This will ensure that changed data are stored in the appliance.

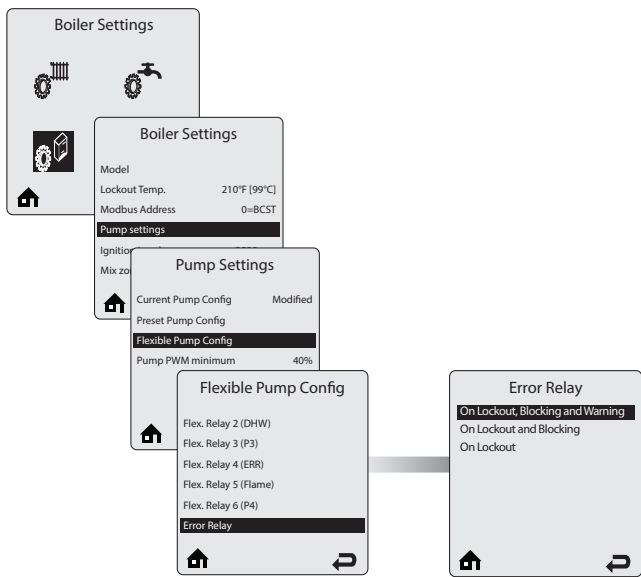

There are three possible selections to activate the **Error Relay** (alarm) contact:

- **On Lockout, Blocking and Warning:** the error relay is activated at a non-volatile lock-out (e.g. CH Flow NTC defect), at a blocking error (self-resetting errors) (e.g. Gas-pressure switch not closed), or at a warning (e.g. low water pressure warning).
- **On Lock-out and blocking:** the error relay is activated at a non-volatile lock-out or a blocking error.
- **On Lockout:** the error relay is activated at a non-volatile lock-out only.

The selection depends on the alarm feedback requirement from the customer.

Scroll through the settings using the **UP** or **DOWN** keys, then validate the selection with the **OK** key.



NOTICE

Although the function and the screen are displayed, this function is not in use. Any change made to the value will not affect the operation of the appliance

The **Ignition Level** parameter allows to change the fan start speed of the appliance. The default value depends on the model and varies according to the table below.

Adjust the Ignition Level value using the **LEFT** or **RIGHT** keys, then store the setting with the **OK** key.

Default: See in table below the fan speed applicable to each appliance/gas combination.

	Natural Gas	Propane
GALLANT 250	3800 rpm	3800 rpm
GALLANT 299	2500 rpm	2500 rpm
GALLANT 399	2650 rpm	2650 rpm
EXALT Heat Only 110	3250 rpm	3250 rpm
EXALT Heat Only/Combi 155	3250 rpm	3250 rpm
EXALT Heat Only/Combi 199	3800 rpm	3800 rpm

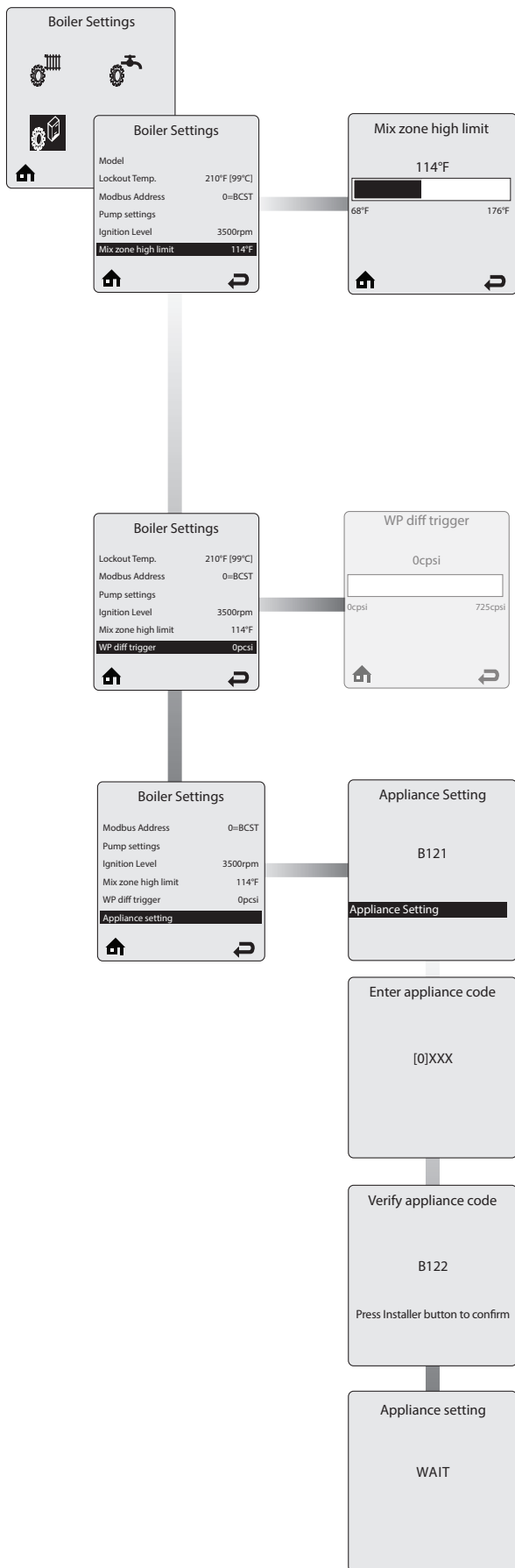

The **Mix zone high limit** setting allows to limit the maximum temperature in the mixed circuit. The function works like an Overheat Cut-off Activation of the limit and will cause the appliance to go in fault state (lockout). This setting allows to change the limit temperature for the mixed circuit.

NOTICE

Be aware that for Floor Heating systems this temperature may NOT be adjusted. A higher temperature setting may damage your floor heating circuit

Adjust the Mix Zone High Limits value using the **LEFT** or **RIGHT** keys, then store the setting with the **OK** key.

Default: 114°F

NOTICE

Although the WP Diff Trigger function and the screen are displayed in Gallant Units, this function is not in use. Any change made to the value will not affect the operation of the appliance.

The **Appliance Setting** allows to change the appliance type and model using a specific code. The appliance type and model are factory preset for the appliance you have received. This means that parameters are already set for the appliance, and the appliance type **MAY NOT** be changed, unless the CTRLMax mainboard is replaced or repaired, or a gas conversion is made to the appliance.

If the appliance type needs to be entered, please refer to the appliance code written on the data plate located at the side of the boiler.

Increase/decrease the value (from 0 to 9, then A to Z) using the **UP** or **DOWN** keys to, then change position with the **LEFT** or **RIGHT** keys.

Once the code has been entered, confirm the code by pressing **OK**, then follow the instructions displayed on the screen: press the installer button (GALLANT), or touch the **UP** key (EXALT).

Actuate the **UP**, **DOWN**, **LEFT** or **RIGHT** keys to go back to the previous screen and change the code if you made a mistake when entering the code.

The software will then process the change and return to the Main screen.

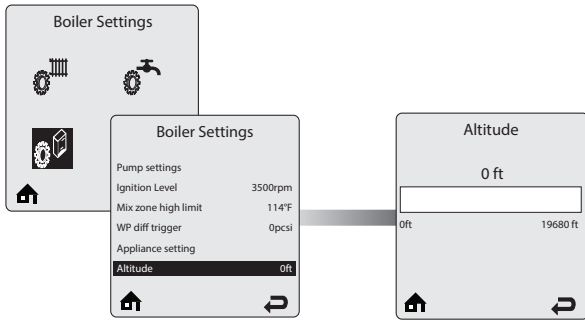

The **Altitude** parameter allows to define the altitude at which your system is installed and compensate for the possible change in air density when in higher altitude. The altitude parameter can be adjusted in steps of 984 ft.

Adjust the Altitude value using the **LEFT** or **RIGHT** keys then validate your selection with the **OK** key.

Default: 0 ft.

5.1. Gallant Boilers - Configuration of Line Voltage Terminals

CHAPTER 5

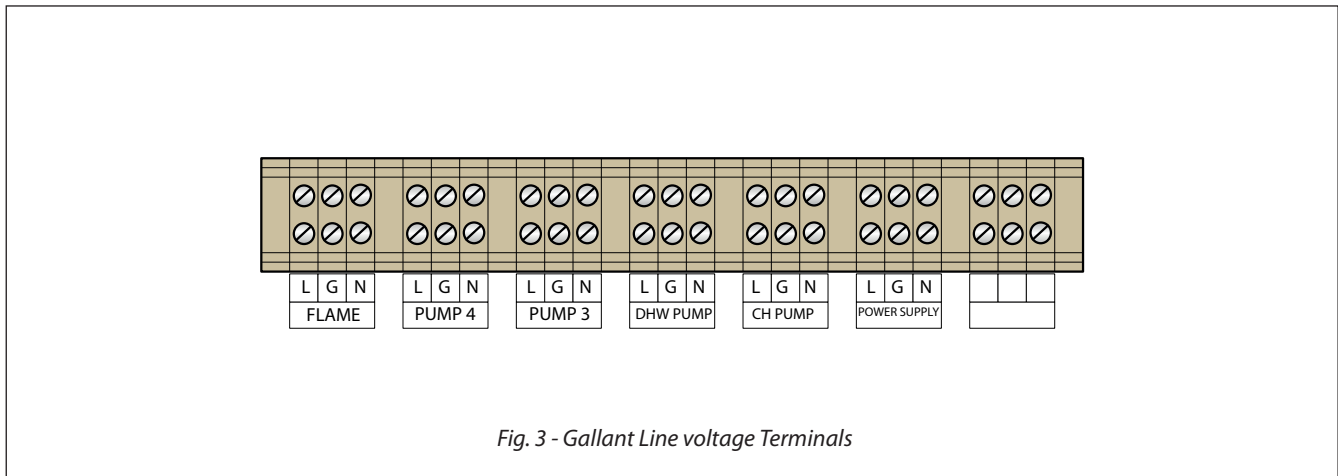

Fig. 3 - Gallant Line voltage Terminals

CHAPTER 5 - BOILER SETTINGS (GALLANT)

GALLANT - PRESET PUMP CONFIGURATION 1

Heat Call	Pump 4	Pump 3	DHW Pump	CH Pump
CH1	OFF	ON	OFF	ON
CH2	ON	ON	OFF	OFF
DHW	OFF	ON	ON	OFF

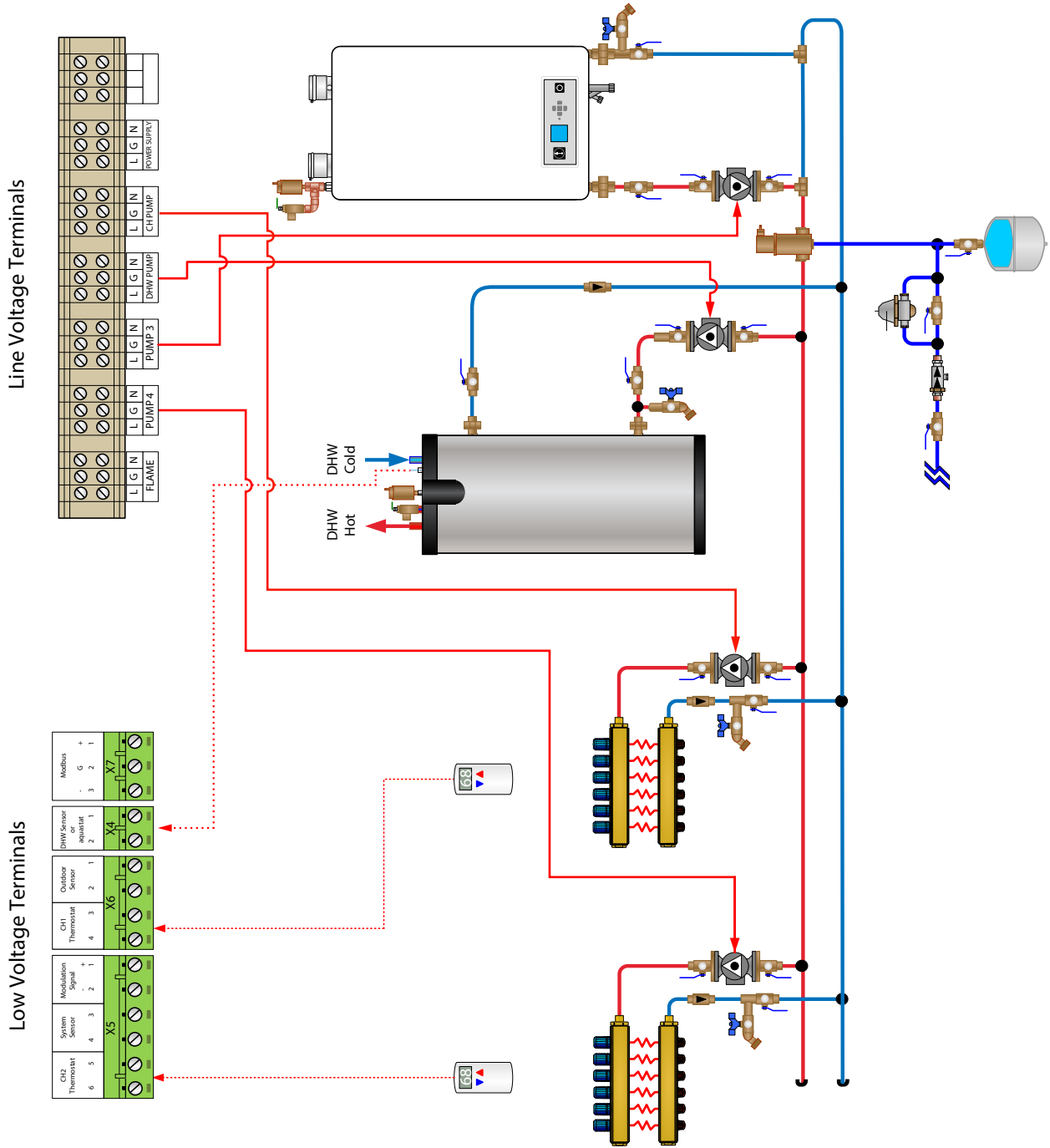

Fig. 4 - System Piping with Preset Config. 1

CHAPTER 5 - BOILER SETTINGS (GALLANT)

GALLANT PRESET PUMP CONFIGURATION 2

Heat Call	Pump 4	Pump 3	DHW Pump	CH Pump
CH1	OFF	ON	OFF	ON
CH2	OFF	ON	OFF	ON
DHW	OFF	ON	OFF	ON

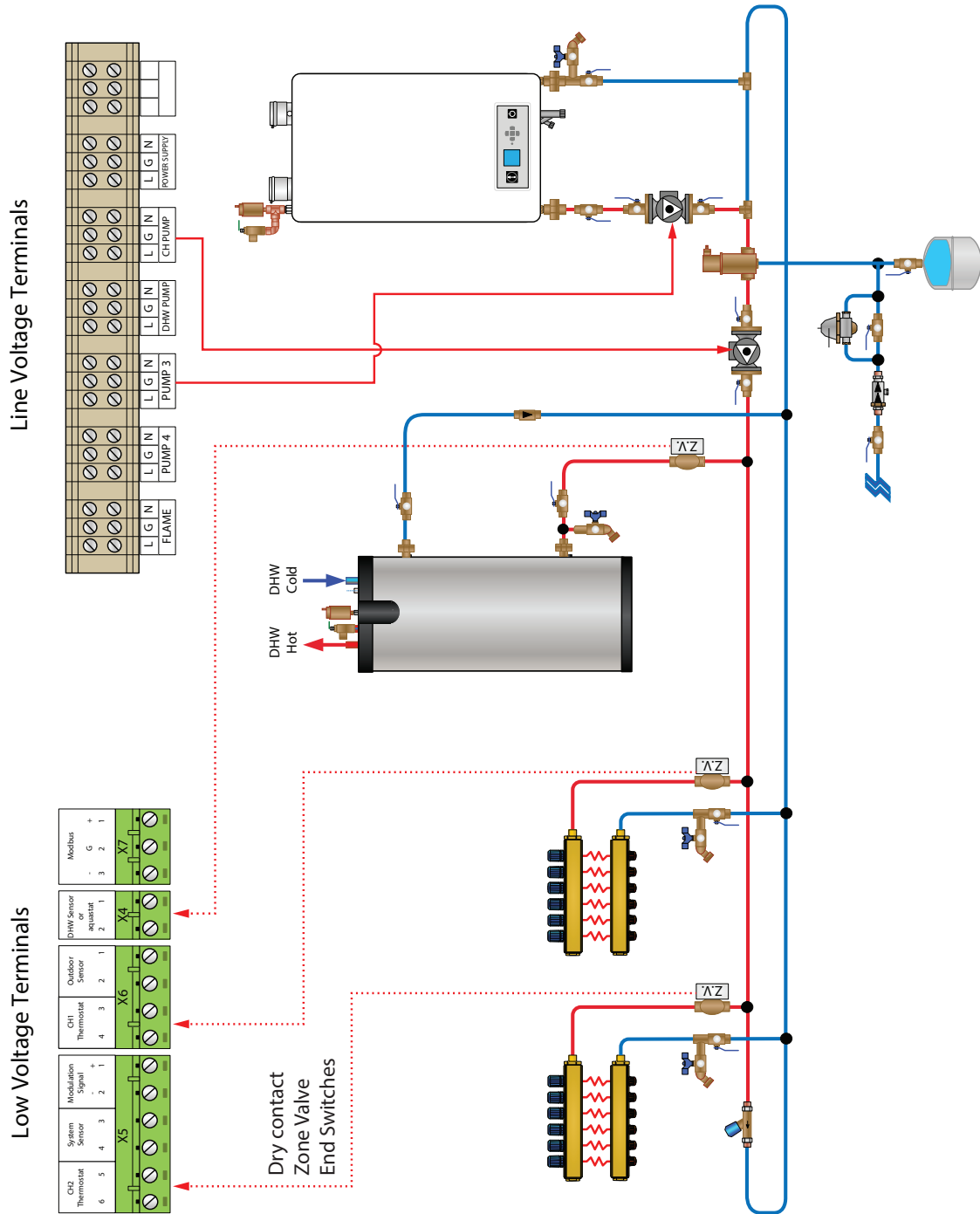

Fig. 5 - System Piping with Preset Config. 2

CHAPTER 5 - BOILER SETTINGS (GALLANT)

GALLANT PRESET PUMP CONFIGURATION 3

Heat Call	Pump 4	Pump 3	DHW Pump	CH Pump
CH1	OFF	ON	OFF	ON
CH2	OFF	ON	OFF	ON
DHW	OFF	OFF	ON	ON

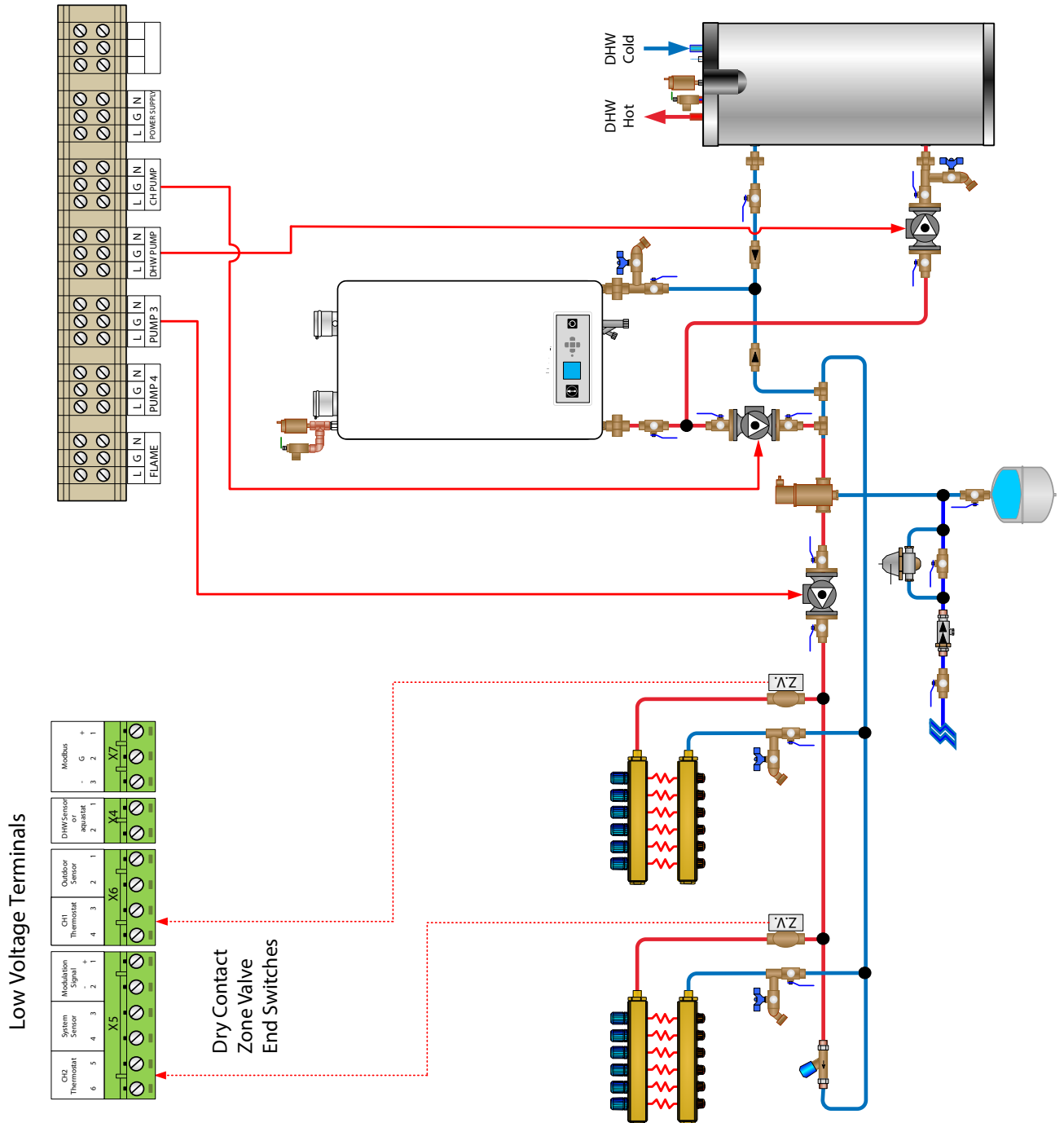

Fig. 6 - System Piping with Preset Config. 3

CHAPTER 5 - BOILER SETTINGS (GALLANT)

GALLANT - PRESET PUMP CONFIGURATION 4

Heat Call	Pump 4	Pump 3	DHW Pump	CH Pump
CH1	OFF	ON	OFF	ON
CH2	ON	ON	OFF	OFF
DHW	OFF	ON	ON	OFF

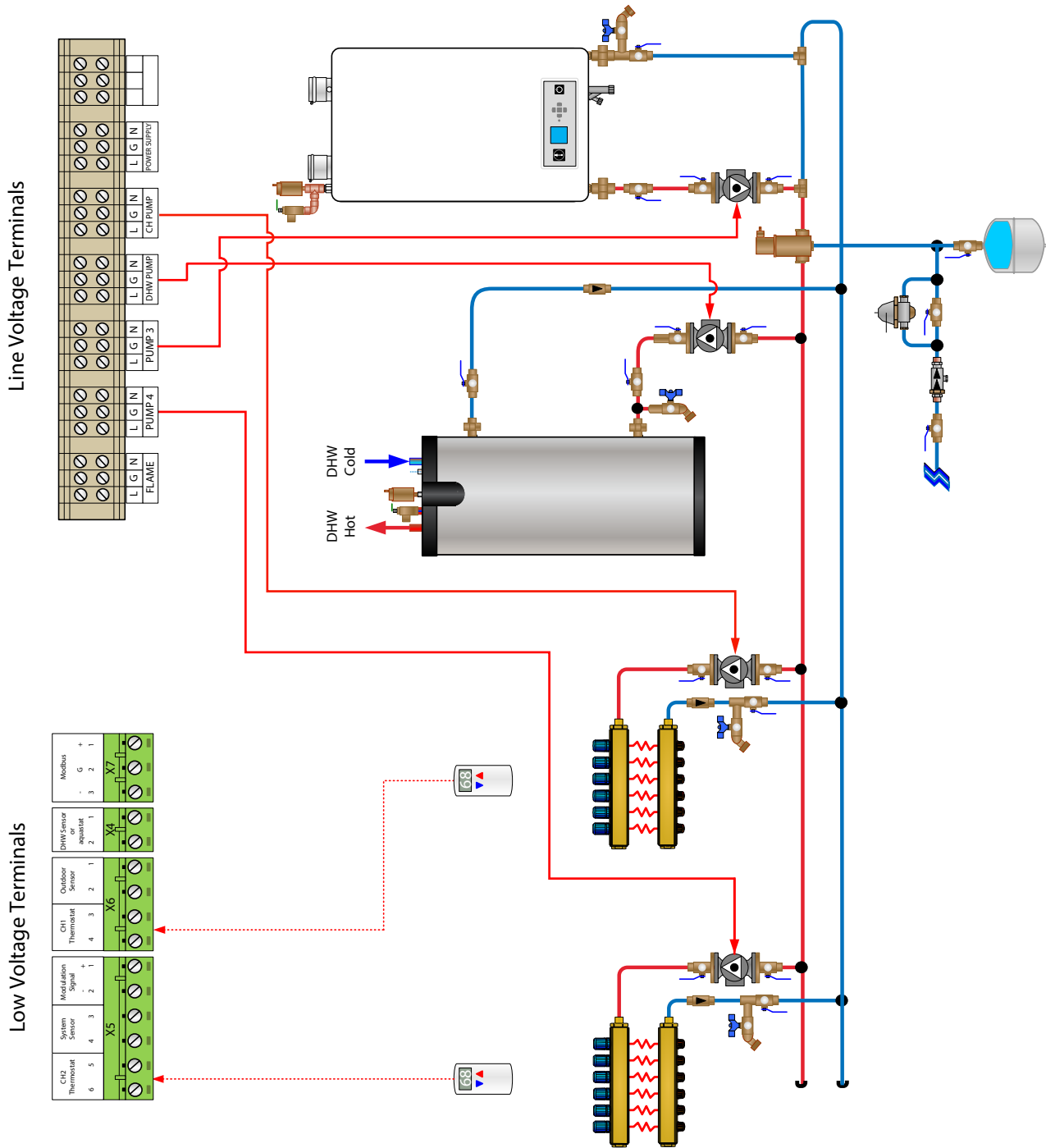

Fig. 7 - System Piping with Preset Config. 4

CHAPTER 5 - BOILER SETTINGS (GALLANT)

GALLANT - PRESET PUMP CONFIGURATION 5

Heat Call	Pump 4	Pump 3	DHW Pump	CH Pump
CH1	OFF	ON	OFF	ON
CH2	ON	OFF	OFF	ON
DHW	OFF	OFF	ON	ON

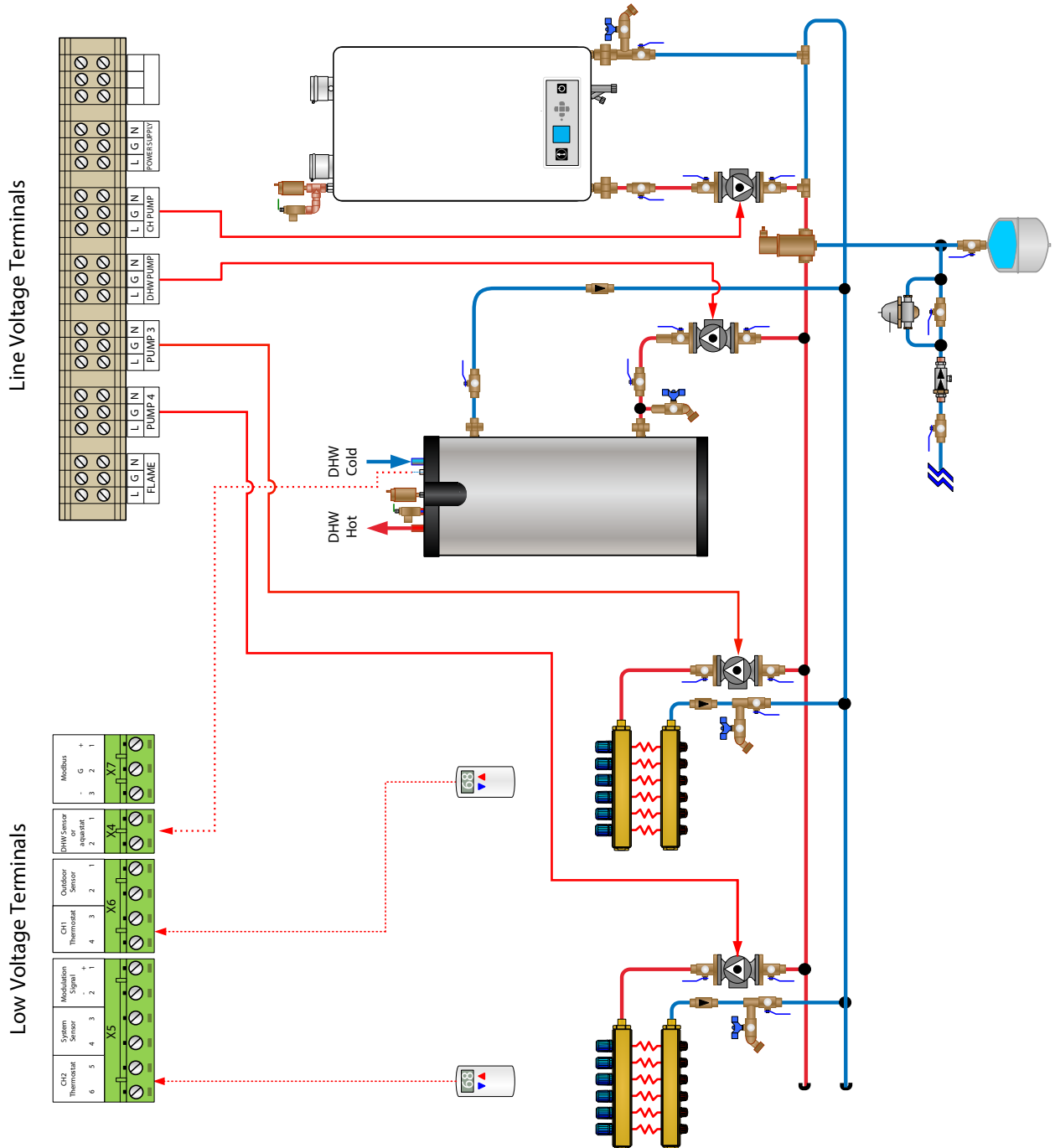

Fig. 8 - System Piping with Preset Config.5

CHAPTER 5 - BOILER SETTINGS (GALLANT)

GALLANT - PRESET PUMP CONFIGURATION 6

Heat Call	Pump 4	Pump 3	DHW Pump	CH Pump
CH1	OFF	ON	OFF	ON
CH2	OFF	ON	OFF	OFF
DHW	OFF	ON	ON	OFF

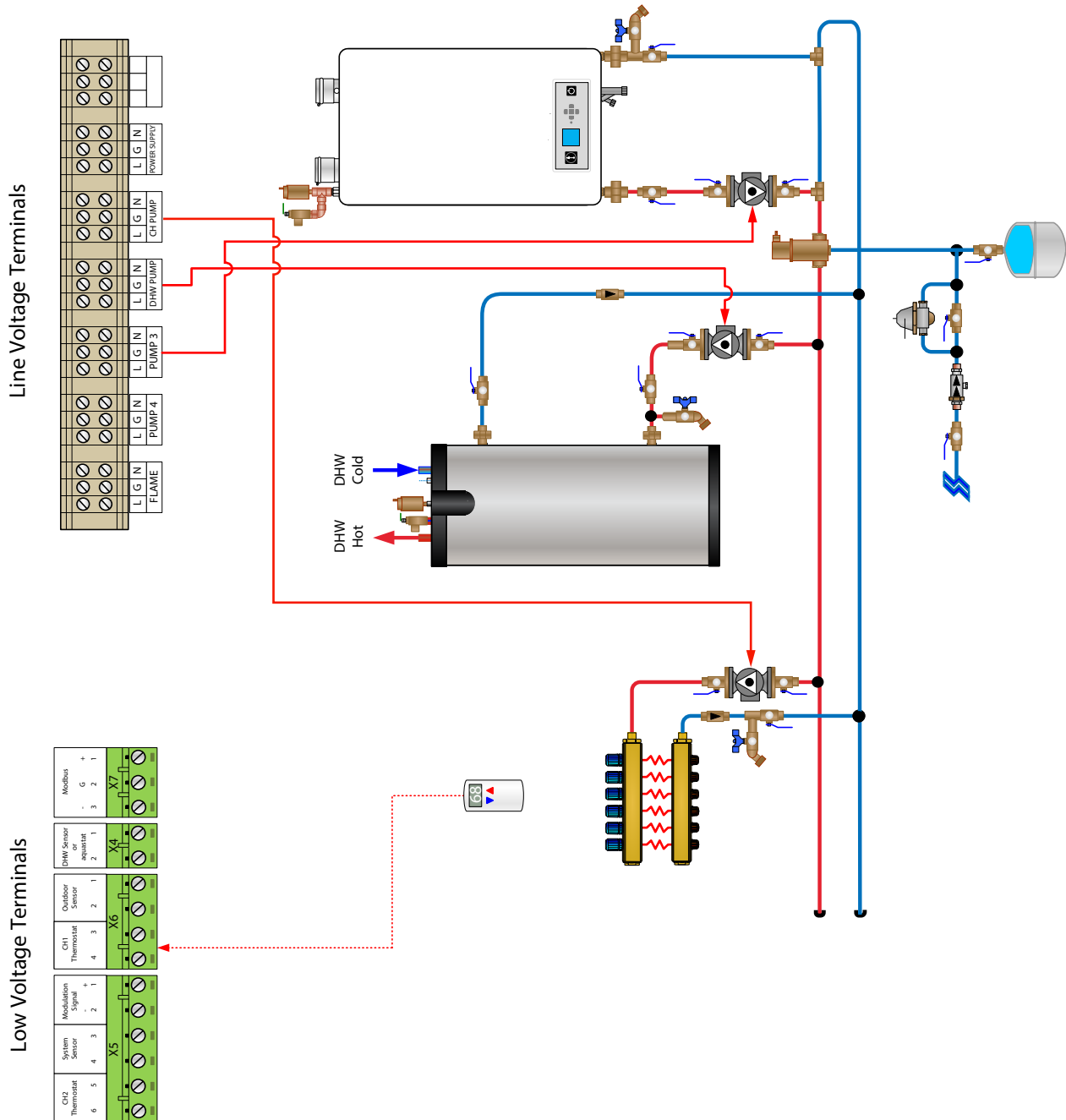
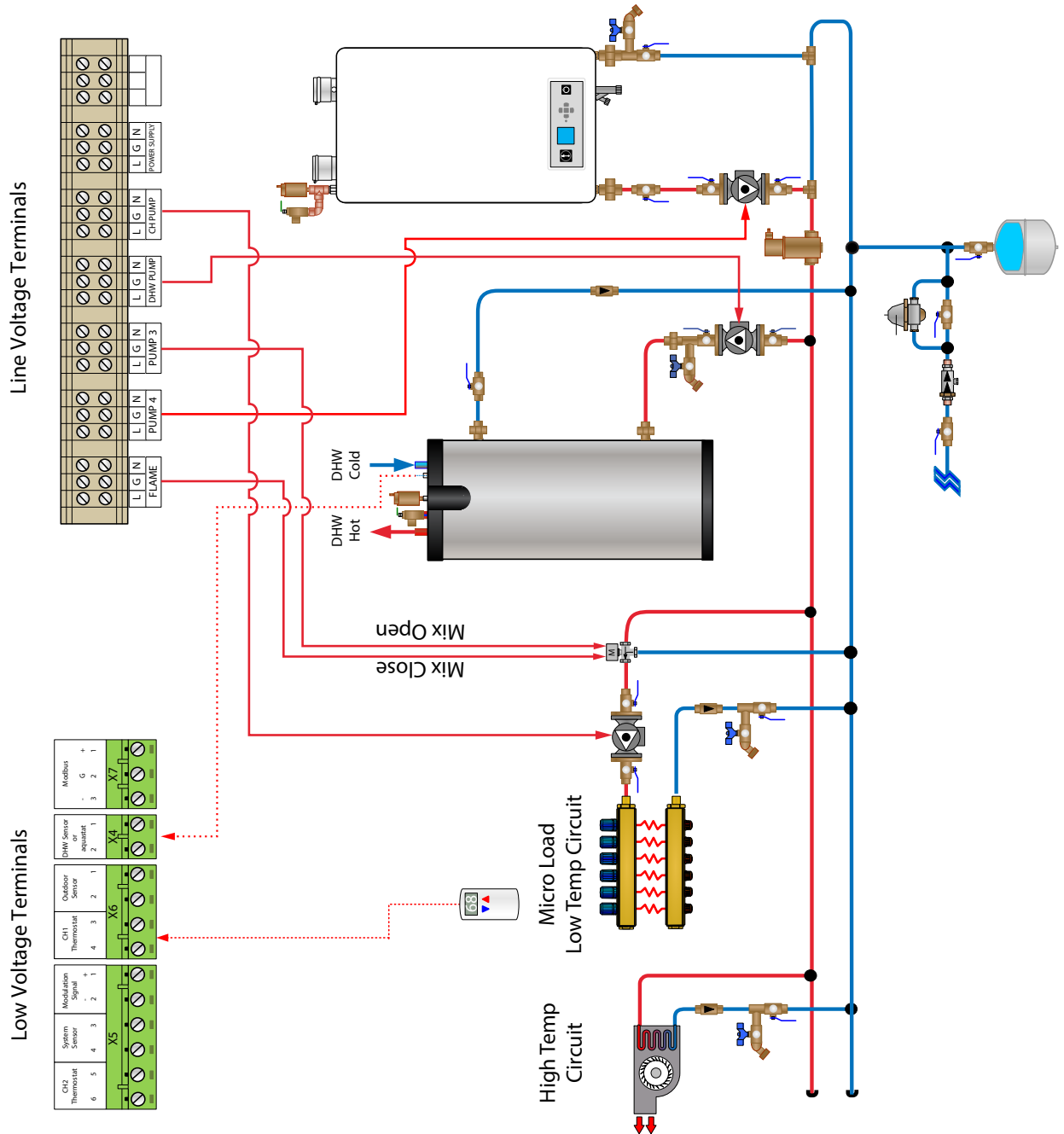

Fig. 9 - System Piping with Preset Config. 6

CHAPTER 5 - BOILER SETTINGS (GALLANT)

GALLANT - PRESET PUMP CONFIGURATION 7

Heat Call	FLAME	Pump 4	Pump 3	DHW Pump	CH Pump
CH1	ON (Mix close)	ON	ON (Mix open)	OFF	ON
CH2	OFF	ON	OFF	OFF	OFF
DHW	OFF	ON	OF	ON	OFF



NOTICE

This configuration is to be used where the Low temp circuit is a micro load and the High temp circuit will run for any call on the Low temp circuit to prevent boiler cycling.

Fig. 10 - System Piping with Preset Config. 7

CHAPTER 5 - BOILER SETTINGS (GALLANT)

GALLANT - PRESET PUMP CONFIGURATION 8

Heat Call	Pump 4	Pump 3	DHW Pump	CH Pump
CH1	OFF	ON	ON	ON
CH2	ON	ON	ON	OFF
DHW	OFF	OFF	ON	OFF

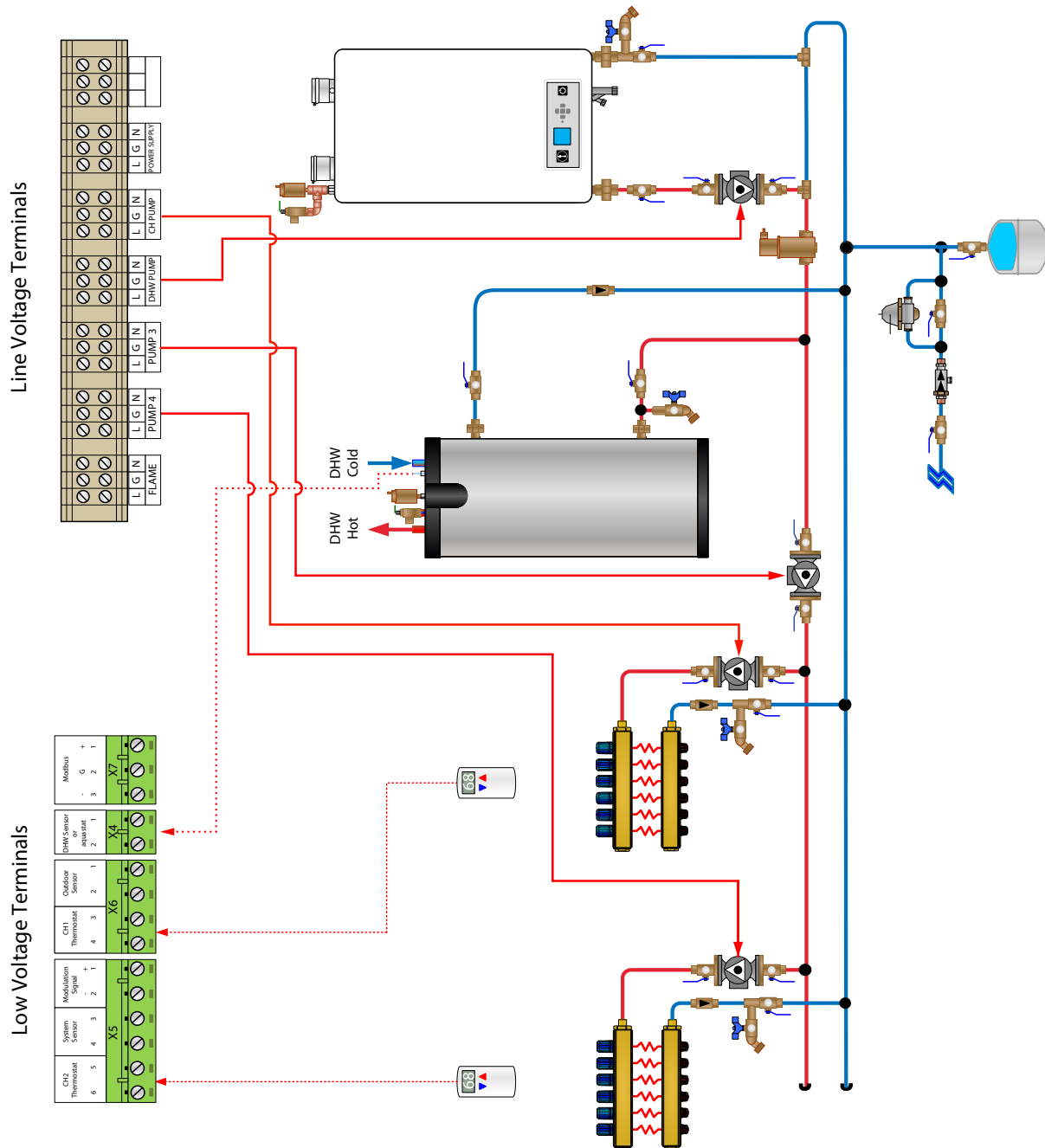
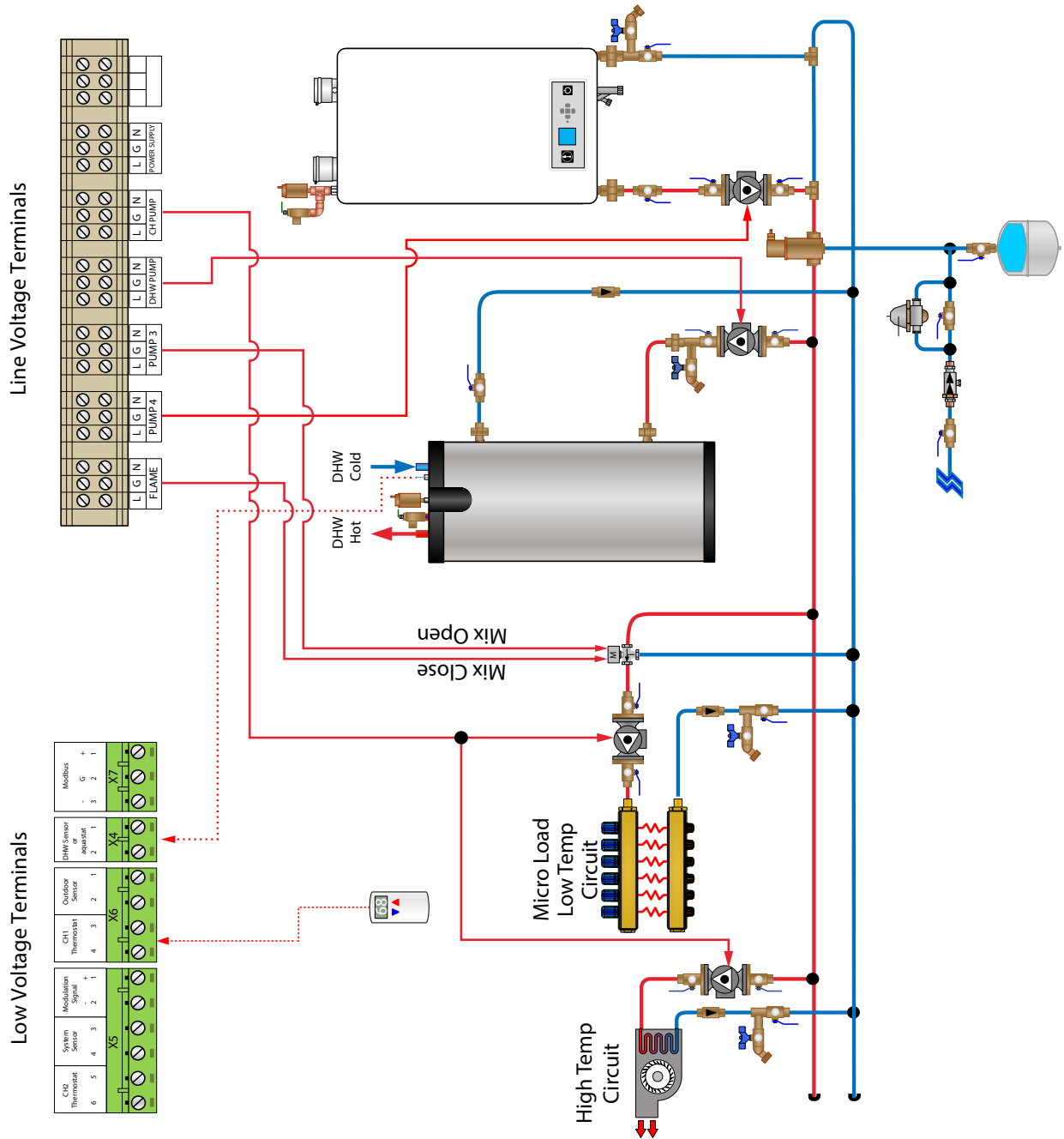

Fig. 11 - System Piping with Preset Config. 8

CHAPTER 5 - BOILER SETTINGS (GALLANT)

GALLANT - PRESET PUMP CONFIGURATION 9

Heat Call	FLAME	Pump 4	Pump 3	DHW Pump	CH Pump
CH1	ON (Mix Close)	ON	ON (Mix open)	OFF	ON
CH2	OFF	ON	OFF	OFF	ON
DHW	OFF	OFF	ON	OFF	



NOTICE

This configuration requires that the Low temp pump and High temp pump be connected in parallel to the CH pump relay. An isolation relay may be used to ensure the CH pump relay will not be overloaded during operation.

Fig. 12 - System Piping with Preset Config. 9

CHAPTER 5 - BOILER SETTINGS (EXALT)

5.2. EXALT Boilers - Preset Pump Configuration

The EXALT boilers come preconfigured for several pre-set pump outputs, to be selected from the Preset Pump config menu.

Only the preset configurations shown in the table below are functional for the EXALT boilers.

Table 1 - EXALT Preset Pump Config Outputs

	Preset Pump Configurations	Boiler Pump	CH1 Pump	CH2 Pump	DHW Pump
EXALT Heat Only	Config A	CH1 Call CH2 Call	CH1 Call CH2 Call		DHW Call
	Config B	CH1 Call CH2 Call DHW Call	CH1 Call	CH2 Call	DHW Call
	Config C	CH1 Call CH2 Call DHW Call	CH1 Call	CH2 Call	DHW Call
EXALT	Config D	CH1 Call CH2 Call DHW Call	CH1 Call CH2 Call	CH1 Call CH2 Call	DHW Call
	Config E	CH1 Call CH2 Call	CH1 Call	CH2 Call	DHW Call
	Config F	CH1 Call CH2 Call	CH1 Call CH2 Call	CH1 Call CH2 Call	DHW Call

CHAPTER 5 - BOILER SETTINGS (EXALT)

5.3. EXALT Boilers - Configuration of Line Voltage Terminals

NOTICE

- EXALT boilers are available in wall-hung and floor-standing models. The connection diagrams shown in the following pages only present wall-hung models, but the connection principles are the same for both types of models.
- EXALT FSB line voltage terminal block has an additional connection terminal compared to that of wall-hung models, that provides for an external 120VAC electrical socket. Refer to the **EXALT FSB Installation and Maintenance Manual** for more information.

EXALT Heat Only Boilers - Line Voltage Terminals

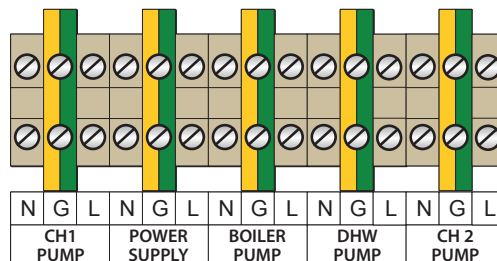

EXALT FSB Heat Only Boilers - Line Voltage Terminals

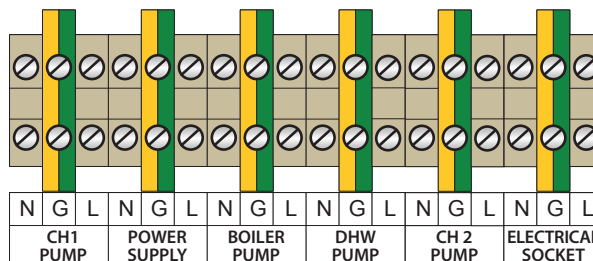

Fig. 13 - EXALT Heat Only Line voltage Terminals

CHAPTER 5 - BOILER SETTINGS (EXALT)

EXALT HEAT ONLY - PRESET PUMP CONFIGURATION "B" OR "C"

Heat Call	Boiler pump	CH1 pump	CH 2 pump	DHW pump
CH1	ON	ON	OFF	OFF
CH2	ON	OFF	ON	OFF
DHW	ON	OFF	OFF	ON

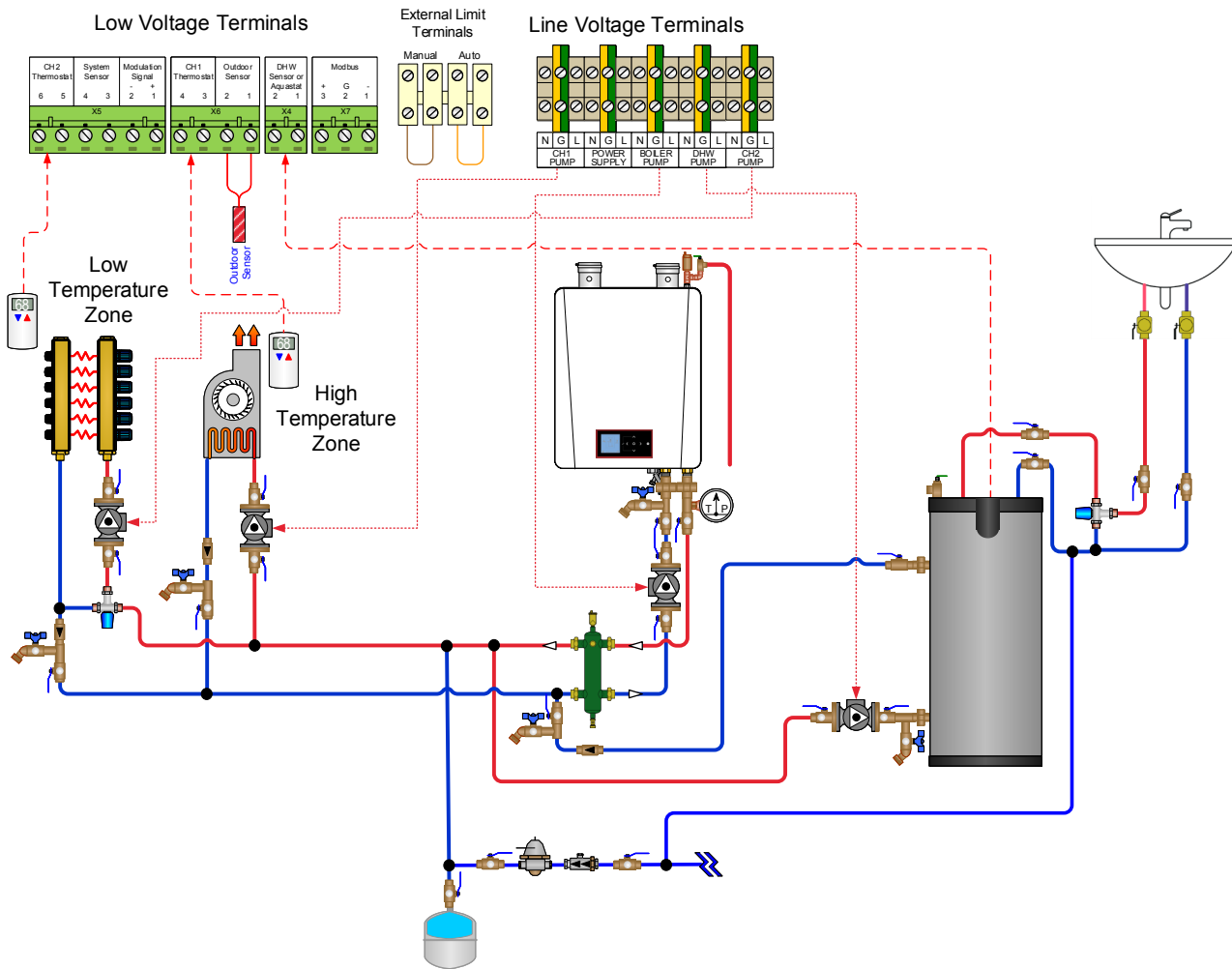

Fig. 14 - EXALT Heat Only System Piping - Multiple Temperature Zone System with Circulators

CHAPTER 5 - BOILER SETTINGS (EXALT)

EXALT HEAT ONLY - PRESET PUMP CONFIGURATION "B" OR "C"

Heat Call	Boiler pump	CH1 pump	CH 2 pump	DHW pump
CH1	ON	ON	OFF	OFF
CH2	ON	OFF	ON	OFF
DHW	ON	OFF	OFF	ON

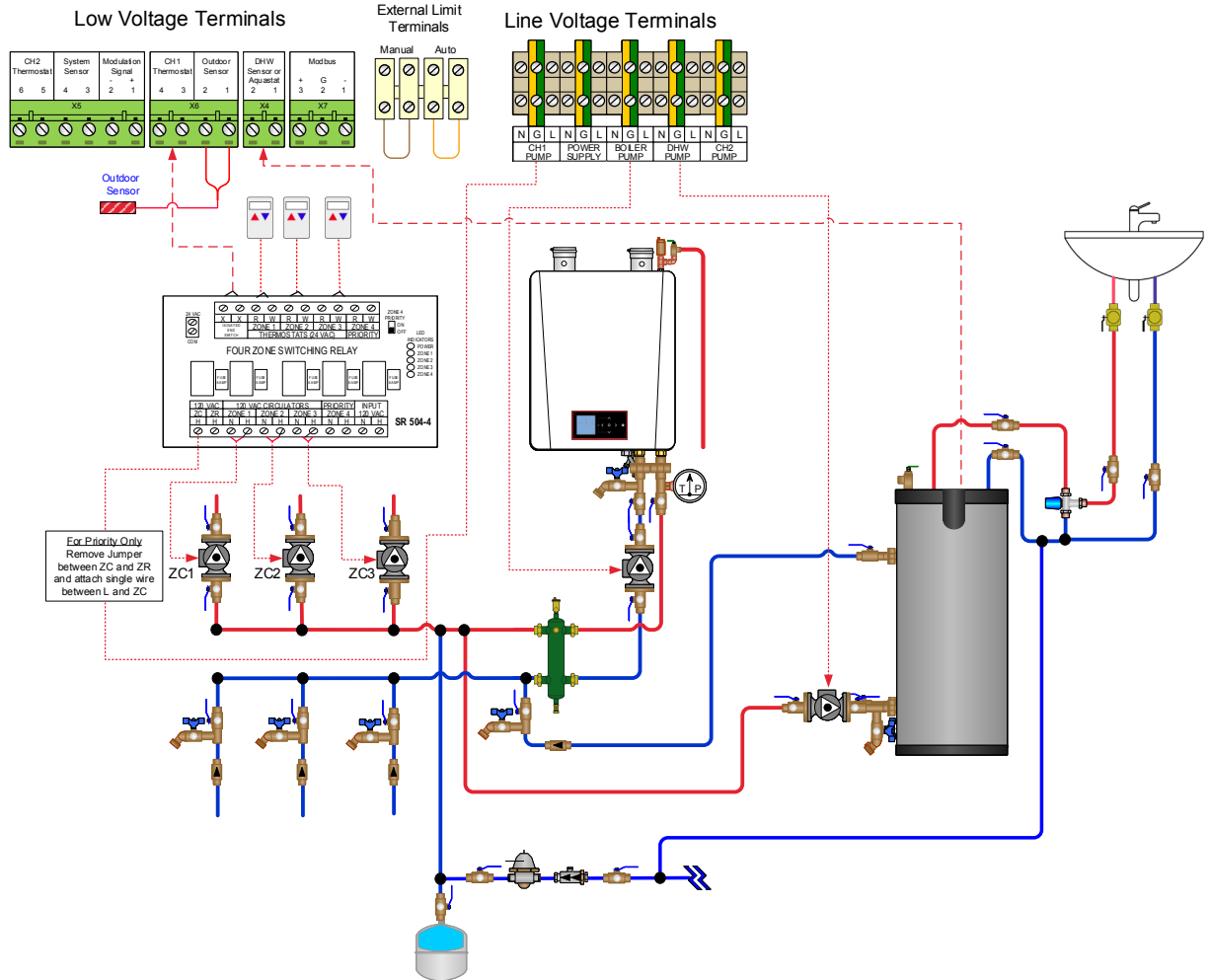

Fig. 15 - EXALT Heat Only System Piping - Multiple Zones with Circulators and Control Panel

CHAPTER 5 - BOILER SETTINGS (EXALT)

EXALT HEAT ONLY - PRESET PUMP CONFIGURATION "D"

Heat Call	Boiler pump	CH1 pump	CH 2 pump	DHW pump
CH1	ON	ON	ON	OFF
CH2	ON	ON	ON	OFF
DHW	ON	OFF	OFF	ON

CHAPTER 5

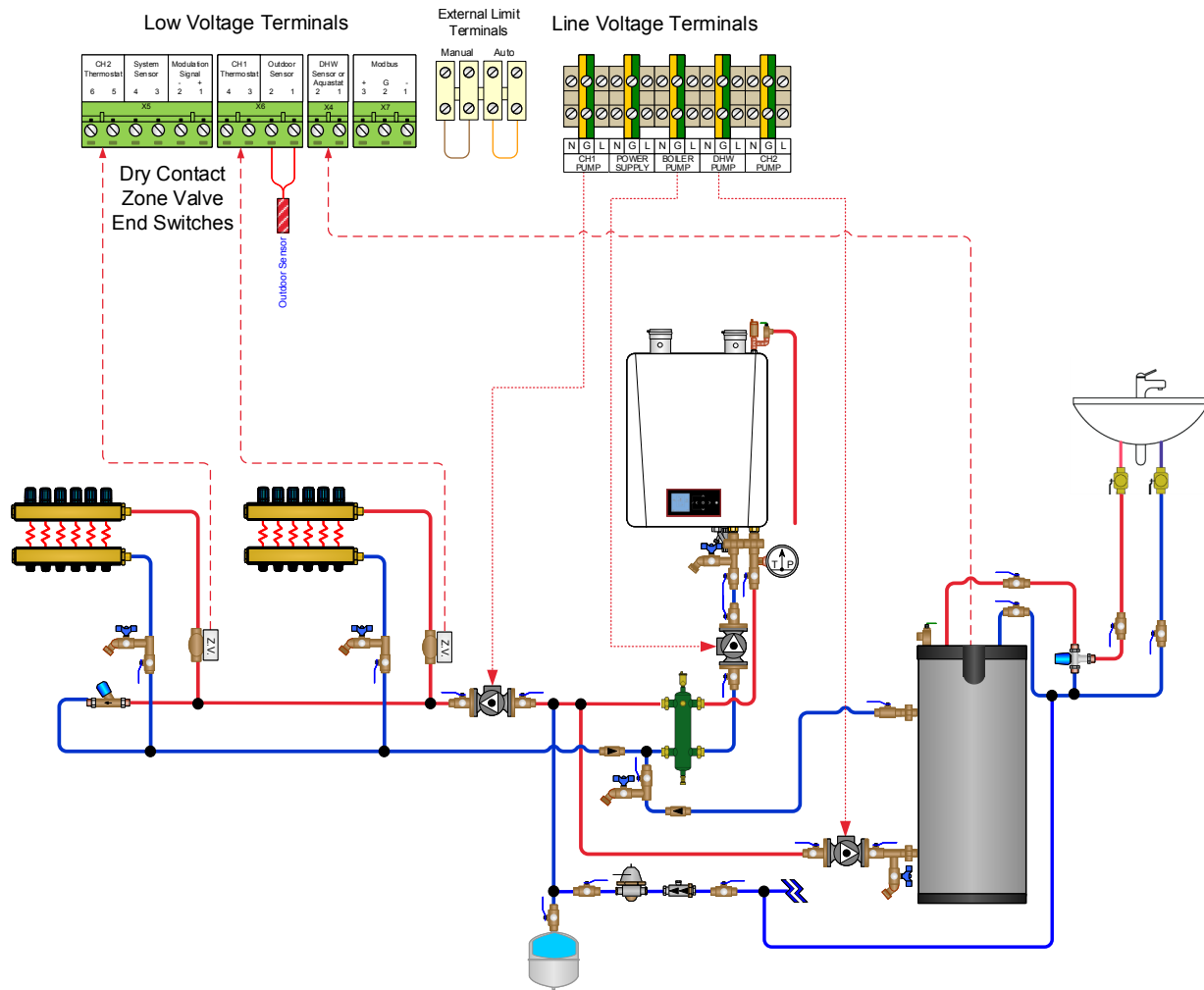

Fig. 16 - EXALT Heat Only System - Piping with Zone Valves

CHAPTER 5 - BOILER SETTINGS (EXALT)

EXALT HEAT ONLY - PRESET PUMP CONFIGURATION "D"

Heat Call	Boiler pump	CH1 pump	CH 2 pump	DHW pump
CH1	ON	ON	ON	OFF
CH2	ON	ON	ON	OFF
DHW	ON	OFF	OFF	ON

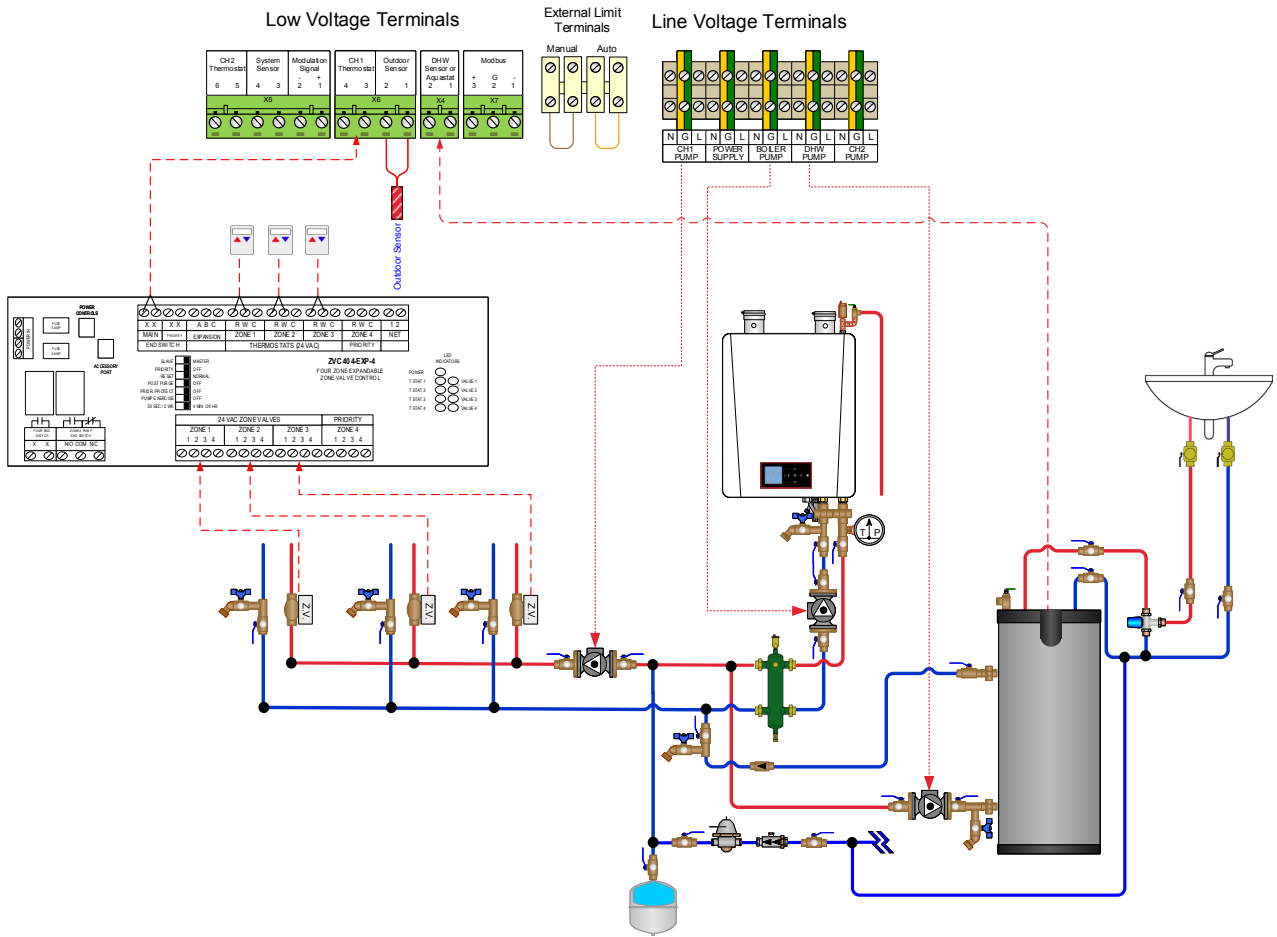

Fig. 17 - EXALT Heat Only System - Piping with Zone Valves and Zone Valve Control Panel

CHAPTER 5 - BOILER SETTINGS (EXALT)

EXALT HEAT ONLY - PRESET PUMP CONFIGURATION "B" OR "C"

Heat Call	Boiler pump	CH1 pump	CH 2 pump	DHW pump
CH1	ON	ON	OFF	OFF
CH2	ON	OFF	ON	OFF
DHW	ON	OFF	OFF	ON

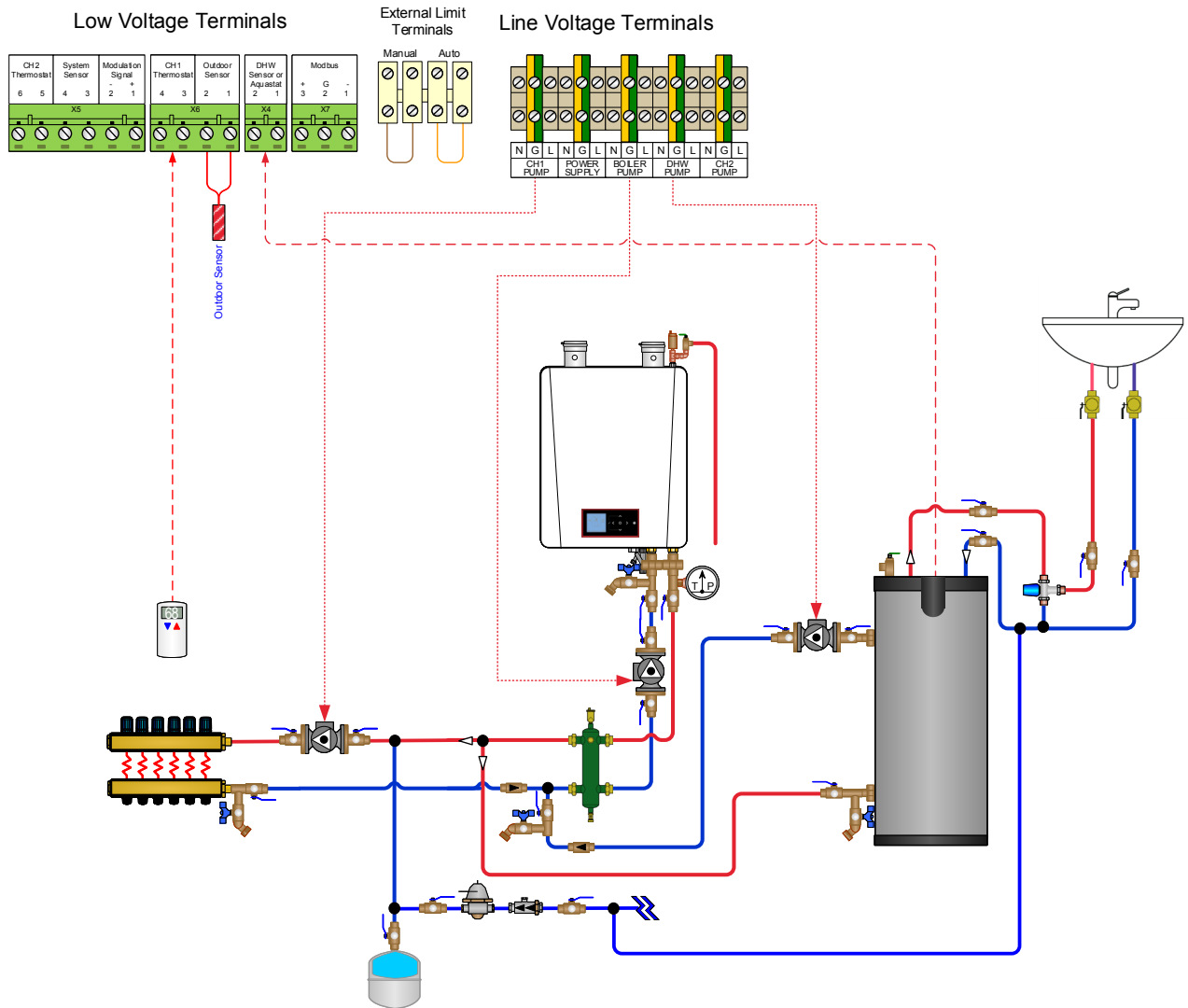

Fig. 18 - EXALT Heat Only System Piping - Single Zone with Circulator

CHAPTER 5 - BOILER SETTINGS (EXALT)

EXALT COMBI - PRESET PUMP CONFIGURATION "C"

Heat Call	Boiler pump	CH1 pump	CH 2 pump	DHW pump
CH1	ON	ON	OFF	OFF
CH2	ON	OFF	ON	OFF
DHW	ON	OFF	OFF	ON

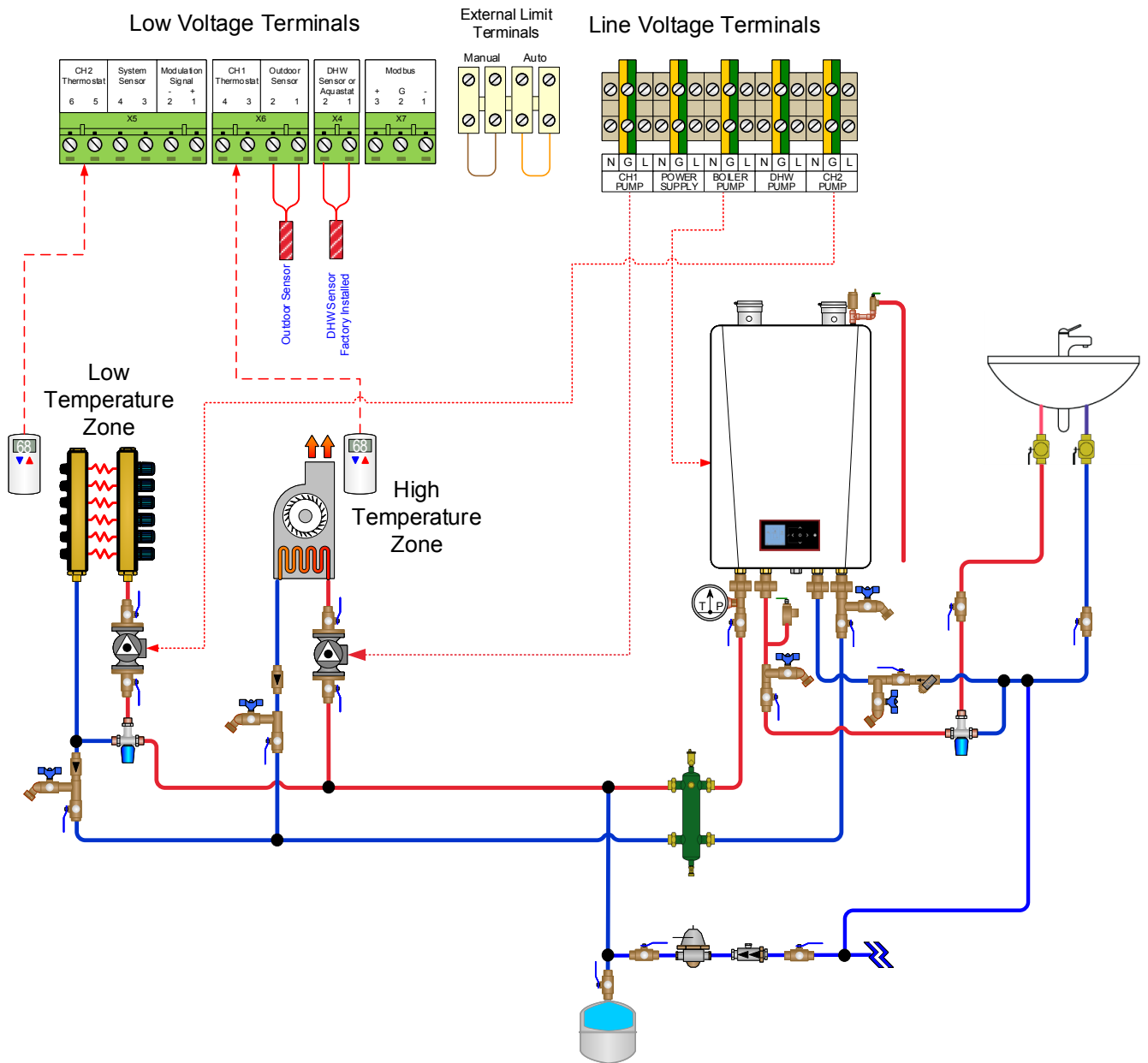

Fig. 19 - EXALT Combi System Piping - Multiple Temperature Zones with Circulators

CHAPTER 5 - BOILER SETTINGS (EXALT)

EXALT COMBI - PRESET PUMP CONFIGURATION "C"

Heat Call	Boiler pump	CH1 pump	CH 2 pump	DHW pump
CH1	ON	ON	OFF	OFF
CH2	ON	OFF	ON	OFF
DHW	ON	OFF	OFF	ON

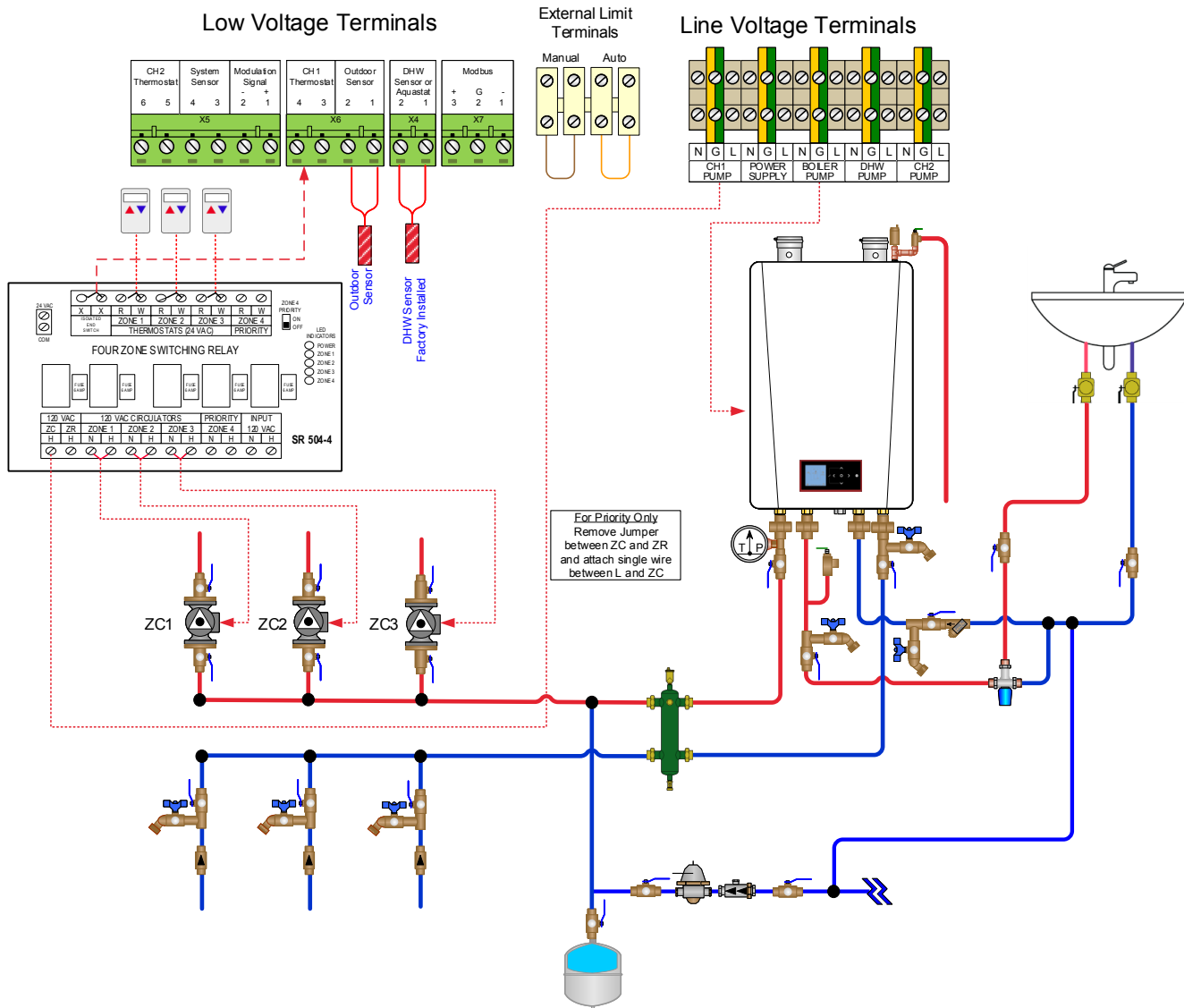

Fig. 20 - EXALT Combi - System Piping - Zoning with Circulators and External Panel

CHAPTER 5 - BOILER SETTINGS (EXALT)

EXALT COMBI - PRESET PUMP CONFIGURATION "C"

Heat Call	Boiler pump	CH1 pump	CH 2 pump	DHW pump
CH1	ON	ON	OFF	OFF
CH2	ON	OFF	ON	OFF
DHW	ON	OFF	OFF	ON

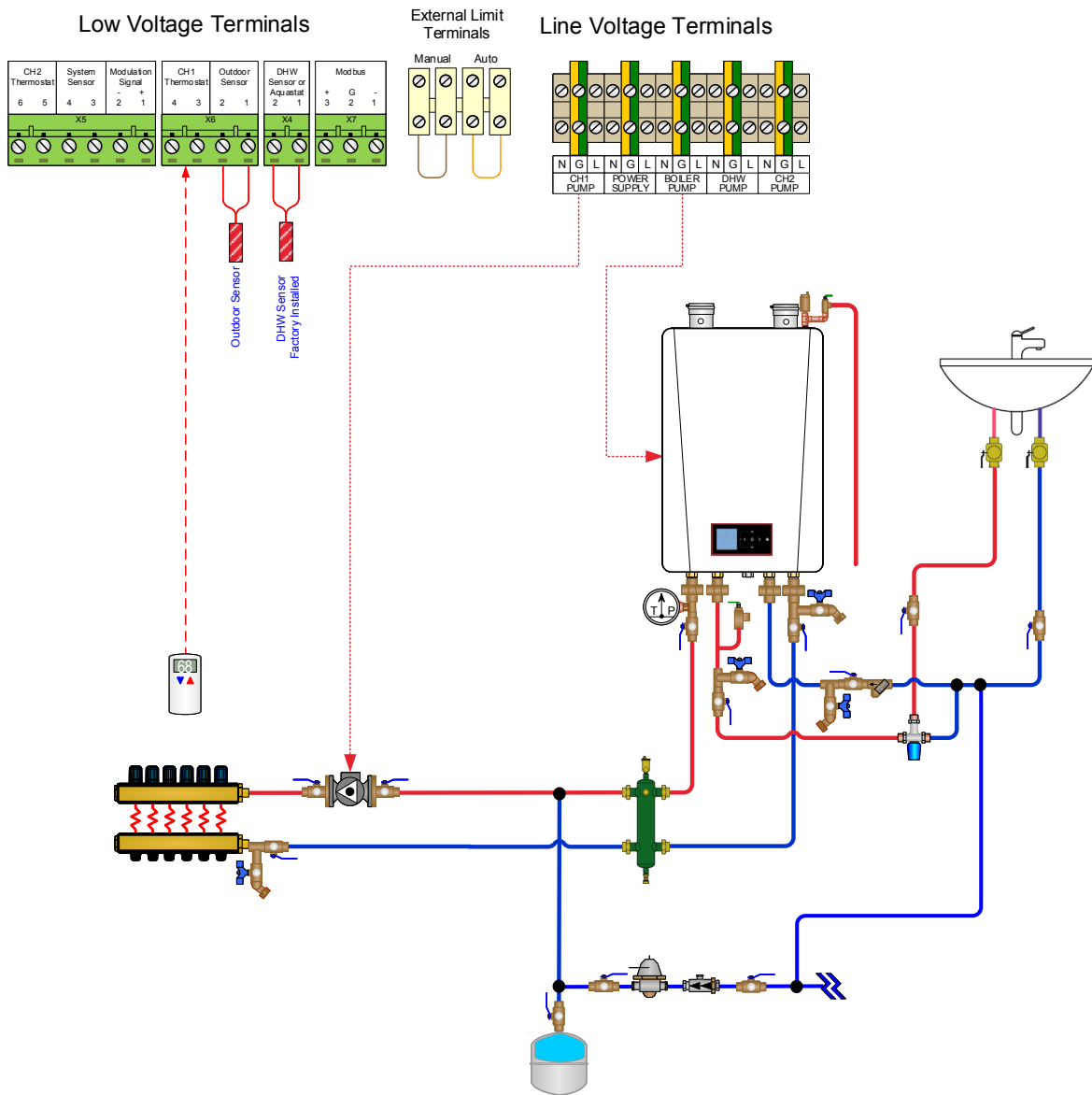

Fig. 21 - EXALT Combi - System Piping - Single Zone with Single Circulator

CHAPTER 5 - BOILER SETTINGS (EXALT)

EXALT COMBI - PRESET PUMP CONFIGURATION "D"

Heat Call	Boiler pump	CH1 pump	CH 2 pump	DHW pump
CH1	ON	ON	ON	OFF
CH2	ON	ON	ON	OFF
DHW	ON	OFF	OFF	ON

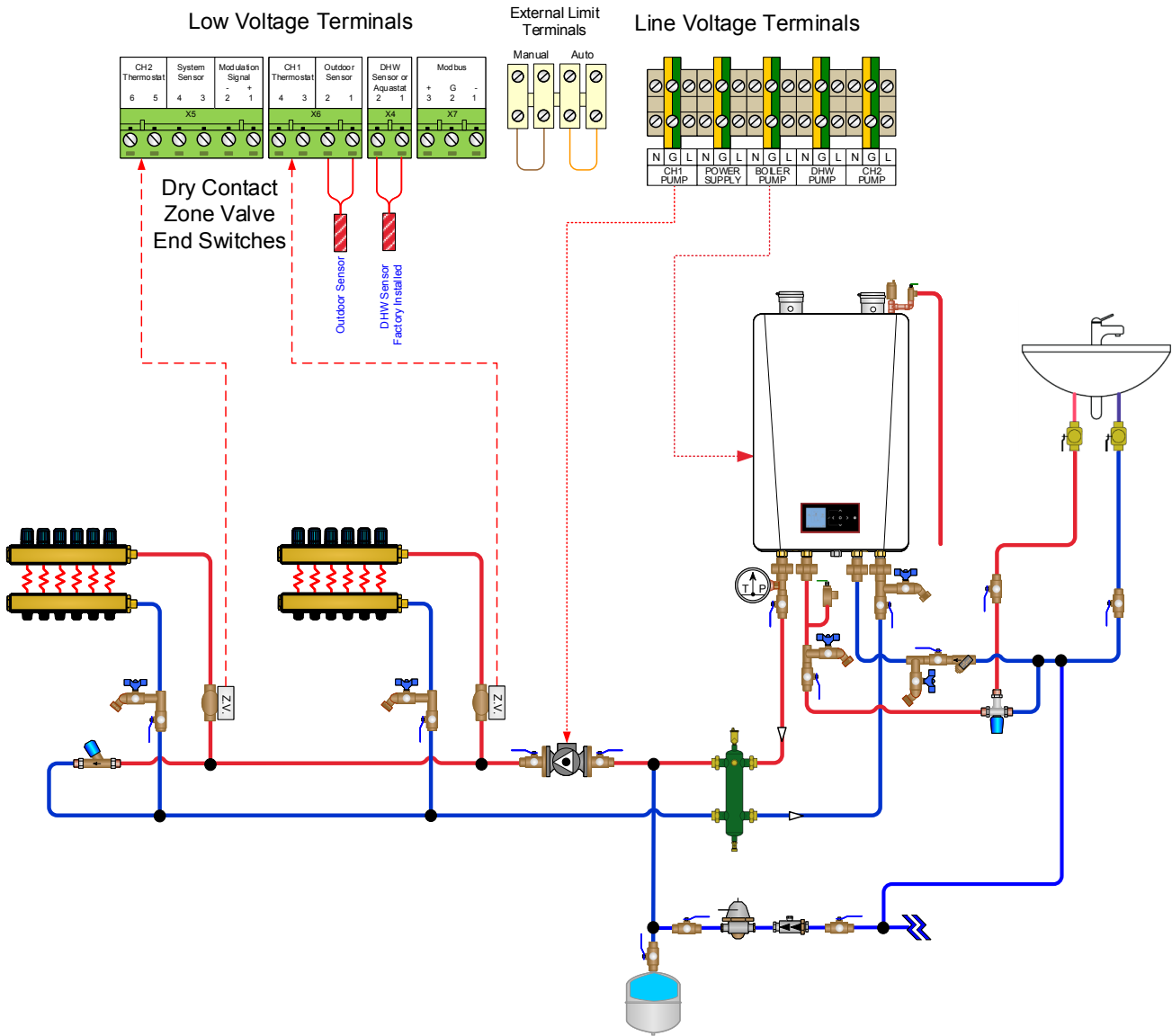

Fig. 22 - EXALT Combi System Piping - Multiple Zones with Zone Valves

CHAPTER 5

CHAPTER 5 - BOILER SETTINGS (EXALT)

EXALT COMBI - PRESET PUMP CONFIGURATION "C"

Heat Call	Boiler pump	CH1 pump	CH 2 pump	DHW pump
CH1	ON	ON	OFF	OFF
CH2	ON	OFF	ON	OFF
DHW	ON	OFF	OFF	ON

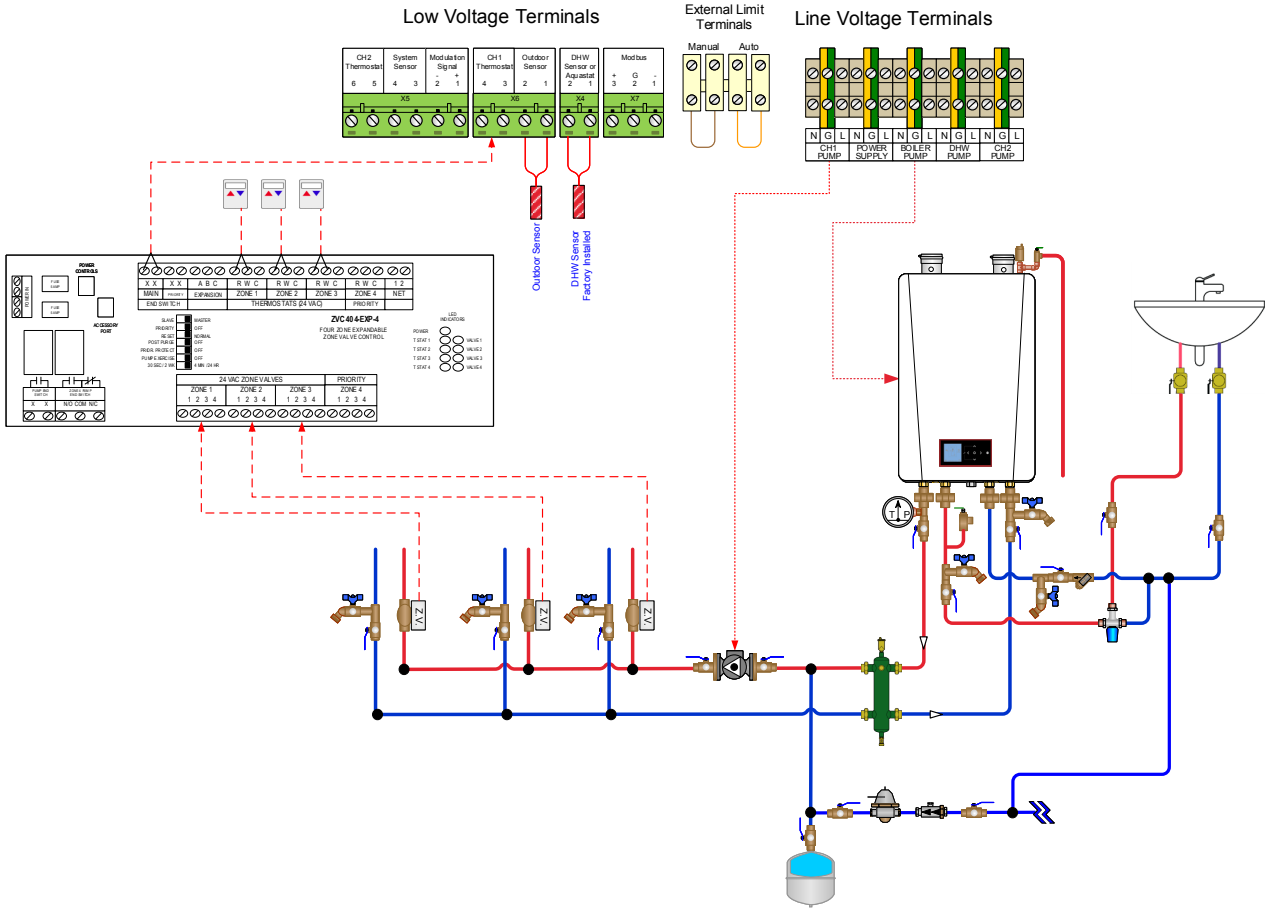
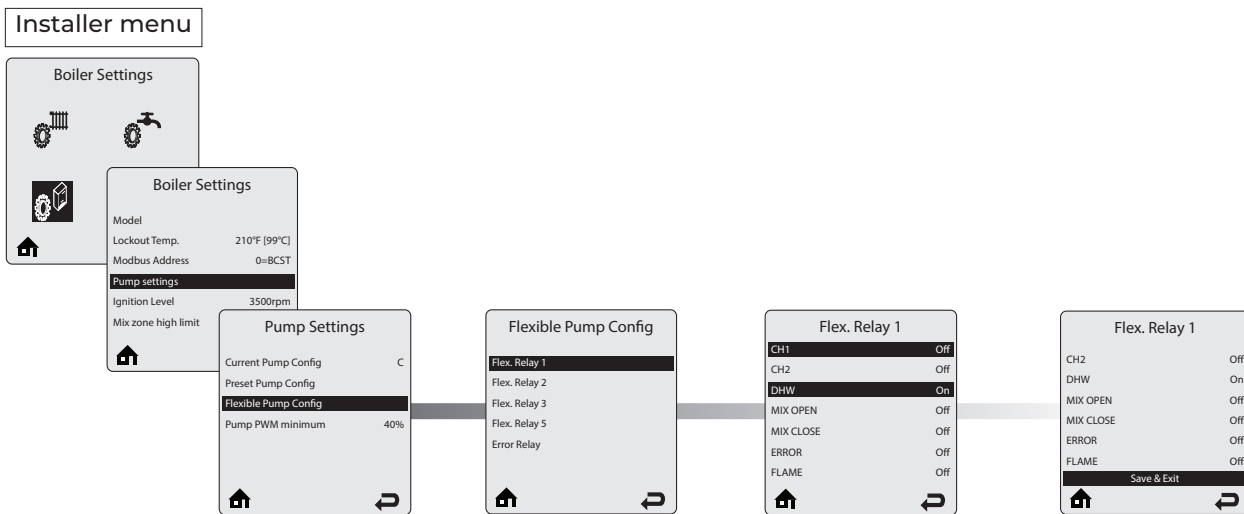

Fig. 23 - EXALT Combi System Piping - Multiple Zones with Zone Valves and Zone Valve control Panel

5.4. EXALT Boilers - Pump Setting Process using the Flexible Pump Config Function

NOTICE

The process below must be followed in order to use the Flexible Pump Config. functions with other EXALT system configurations whose configuration is not covered by the Preset Pump Configurations. Refer to "Flexible Pump Config." on page 24 for more information on this function. For specific adjustments, please contact Ideal's technical support.



NOTICE

- Scroll down the list of inputs of the selected Flex Relay, setting each of them **ON** or **OFF** according to the system output requirements.
- To save your changes, make sure to scroll down to the last line of the screen until **Save & Exit** is highlighted, then press the **OK** key.

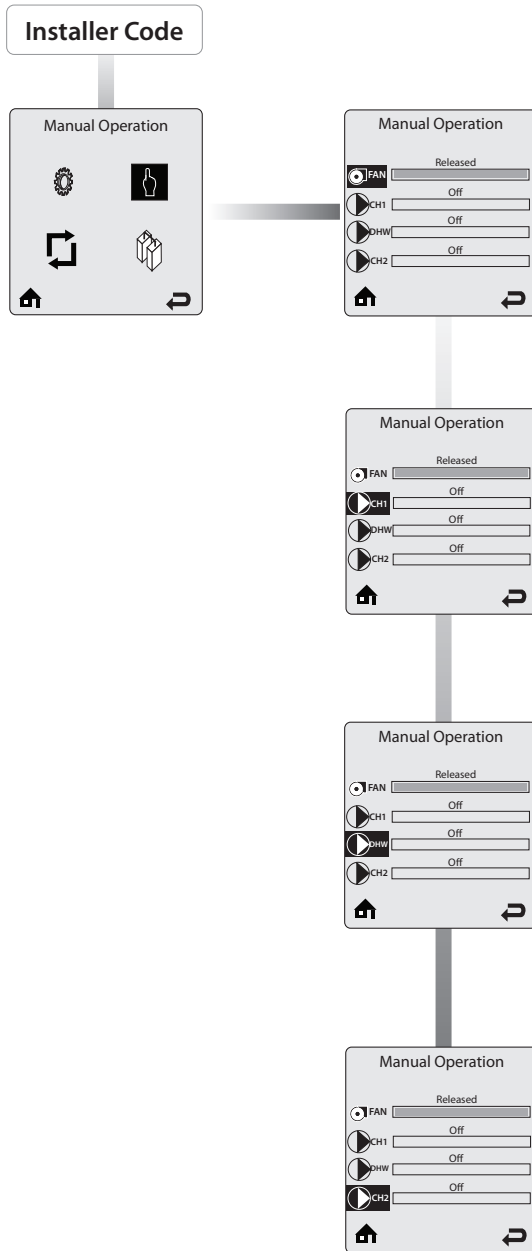

FAN - Actuate the **OK** key while the FAN icon is highlighted to manually fire the burner and power the CH (1) circulator. Adjust the firing rate from 0% (Low Fire) to 100% (High Fire) using the **LEFT** and **RIGHT** keys. Hold down the **LEFT** or **RIGHT** keys to rapidly increase or decrease the firing rate. Actuate the **OK** key again while the FAN icon is highlighted to shutdown the burner when finished.

CH1 - Actuate the **OK** key while the CH1 icon is highlighted to manually power the CH 1 circulator(s) as in CH demand. Actuate the **OK** key again while the CH1 icon is highlighted to shutdown the CH1 circulator(s).
i **The auxiliary Appliance circulator is also powered when the CH1 circulator is manually enabled.**

DHW - Actuate the **OK** key while the DHW icon is highlighted to manually power the DHW circulator(s) as in DHW demand. Actuate the **OK** key again while the DHW icon is highlighted to shutdown the DHW circulator(s).
i **The auxiliary Appliance circulator is also powered when the DHW circulator is manually enabled.**

CH2 - Actuate the **OK** key while the CH2 icon is highlighted to manually power the CH2 circulator(s) as in CH demand. Actuate the **OK** key again while the CH2 icon is highlighted to shutdown the CH2 circulator(s).

NOTICE

To ensure the operation of the heating system, make sure to switch on one of the pumps.

INTENTIONALLY LEFT BLANK

CHAPTER 7 - RESET ALL SETTINGS

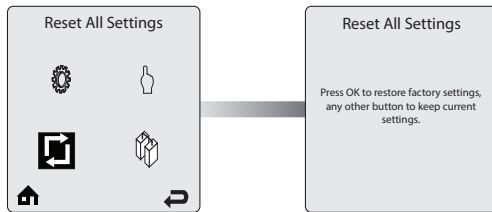

Reset All Settings allows the installer to reset all CH, DHW, and Cascade settings back to the default values (See below).

Follow the on-screen instructions to reset all settings back to the factory default values.

7.1. Factory CTRLMax Settings

HEATING SETTING	FACTORY DEFAULT			MINIMUM SETTING	MAXIMUM SETTING	EZ SETUP RESET	INSTALLER RESET
	GALLANT	EXALT Heat Only	EXALT Combi				
Heating Operation	Enabled						✓
Demand Type	Thermostat & Outd. Curve					✓	✓
CH max. capacity	100%			0%	100%		
CH min capacity	0%			0%	100%		
Absolute Max CH Setpoint	186°F [85°C]			68°F [20°C]	188°F [87°C]	186°F [85°C]	✓
CH1 Maximum Setpoint	180°F [82°C]			68°F [20°C]	188°F [87°C]	180°F [82°C]	✓
CH1 Minimum Setpoint	80°F [27°C]			60°F [15°C]	188°F [87°C]	✓	✓
Outdoor Curve Coldest Day	10°F [-12°C]			-30°F [-34°C]	50°F [10°C]		✓
Outdoor Curve Warmest Day	64°F [18°C]			60°F [15°C]	78°F [25°C]		✓
CH2 Circuit	Enabled						✓
CH2 Maximum Setpoint	140°F [60°C]			68°F [20°C]	188°F [87°C]	✓	✓
CH2 Minimum Setpoint	80°F [27°C]			60°F [15°C]	186°F [88°C]	✓	✓
Warm Weather Shutdown	Off			Off	78°F [25°C]	✓	✓
Circulation Pump Permanent	Disabled						✓
CH Post Pump Time	5 Minutes			Off	20 Minutes		✓
Freeze Protection	Enabled						✓
Frost Protection Setpoint	-22°F [-30°C]			-22°F [-30°C]	50°F [10°C]		✓
Parallel Shift Value	0°F [0°C]			0°F [0°C]	144°F [80°C]		✓
CH Call Blocking	2 Minutes			0 Minute	30 Minutes		✓
Appliance min CH Setpoint	60°F			60°F	188°F		

CHAPTER 7 - RESET ALL SETTINGS

DHW SETTING	FACTORY DEFAULT			MINIMUM SETTING	MAXIMUM SETTING	EZ SETUP RESET	INSTALLER RESET
	GALLANT	EXALT Heat Only	EXALT Combi				
DHW Operation		Enabled					✓
Demand Type	Thermostat	Thermostat	—				
DHW Boiler Setpoint	168°F [75°C]	168°F [75°C]	—	96°F [35°C]	188°F [87°C]	✓	✓
DHW Setpoint		140°F [60°C]		68°F [20°C]	186°F [85°C]	✓	✓
DHW maximum capacity	100%	100%	—	0%	100%		
DHW On Differential	6°F [3°C]	6°F [3°C]	18°F [10°C]	4°F [2°C]	18°F [10°C]		✓
DHW Warmstart Setpoint	—	—	125°F [52°C]	86°F [30°C]	140°F [60°C]		
DHW Warmstart Hysteresis	—	—	30°F [17K]	9K	36K		
DHW Storage Adder	27°F [15°C]	27°F [15°C]	—	10°F [5°C]	54°F [30°C]		✓
DHW Post pump time		2 Minutes		Off	30 Minutes		
DHW Priority Timeout		Off		Off	120 Minutes	✓	✓
DHW Priority		Enabled					✓
DHW Call Blocking		1 Minute		0 Minute	30 Minutes		✓
DHW to CH Call Blocking		1 Minute		0 Minute	30 Minutes		✓
Antilegionella Function	Disabled	Disabled	—			Enabled	✓
DHW ramp up	Off	Off	—	Off	54°F [30°C]		

BOILER SETTING	FACTORY DEFAULT			MINIMUM SETTING	MAXIMUM SETTING	EZ SETUP RESET	INSTALLER RESET
	GALLANT	EXALT Heat Only	EXALT Combi				
Lockout Temp.		210°F [99°C]					✓
Modbus Address		0=BCST		0=BCST	247		✓
Flex. Relay 1(CH)		CH1					
Flex. Relay 2 (DHW)		DHW					
Flex. Relay 3 (P3)	CH1/CH2/DHW	—	—				
Flex. Relay 4 (ERR)	ERROR	—	—				
Flex. Relay 5 (Flame)		FLAME					
Flex. Relay 6 (P4)	CH2	—	—				
Error Relay	On Lockout, Blocking and Warning						
Ignition Level NAT	Varies by model						
Mix Zone High Limit		114°F [45°C]		68°F [20°C]	176°F [80°C]		
WP diff trigger	0cpsi	0cpsi	0cpsi	0cpsi	725cpsi		
Altitude		0ft		0ft	19680ft		

CASCADE SETTING	FACTORY DEFAULT	MINIMUM SETTING	MAXIMUM SETTING	EZ SETUP RESET	INSTALLER RESET
Stage Delay	60 Seconds	0 Seconds	255 Seconds		✓
Minimum Firing Rate	18%	0%	100%		✓
Max. Firing Rate	Varies by model	0 MBH [0kW]	869 MBH [255kW]		✓
CH/DHW Boilers	0	0	6		✓
Auto. Rotation	Enabled				✓
CH Prop. Gain	7	1	255		✓
CH Integral Gain	245	1	255		✓
DHW Prop. Gain	7	1	255		✓
DHW Integral Gain	245	1	255		✓

8.1. Operating Principles of an CTRL-Max-Controlled Cascade (Only GALLANT and EXALT Heat Only)

GALLANT and EXALT Heat Only boilers can be setup in a cascade configuration (max. 6 boilers) that is controlled by the CTRLMax Boiler Control System.

The boilers can operate together without the need for an external cascade controller. One unit will be selected as the Master and will be wired to accept all the low voltage control signals and all the system pumps. The Master appliance organizes the distribution of the heat demands over the appliances in the cascade

The other boilers will be designated as Slaves and will only respond to calls from the Master Boiler and will not respond to internal sensors. The internal supply sensor will still limit the local.

The CH heat demands follow the same logic as the heat demands in a single appliance: the target setpoint at first start-up is calculated, following a temperature rise of 7.2°F/min. The start-up sequence calculates the desired capacity according to the target setpoint.

The first appliance starts and as soon as it reaches twice the minimum capacity of the appliance, the second appliance will be started when the stage delay has expired. Both appliances are then running at minimum capacity.

The capacity increase continues following the rise of the calculated target setpoint. The third appliance will be started as soon as the two appliances have reached 3 times the minimum capacity. The cascading strategy is to have more boilers running at lower speeds than less boilers running at higher speeds

The control parameters to determine the control speed of the cascade is derived from the individual appliance capacity parameter.

As soon as the System temperature comes in reach of the target system temperature the capacity increase will stop and the normal temperature control takes over.

NOTICE

Be aware that in a cascade the temperature control is done on the system temperature and NOT on the local temperature. That means that the local temperature can be easily 9 to 12°F higher than the system temperature depending on the position of the system sensor.

The Cascade control works as a power control on the local appliances. The system temperature is the parameter to regulate and the local temperatures are of no avail, they are only used to limit the local power in case the max. temperature is reached.

Additional characteristics :

1. The Cascade function allows up to six identical boilers to operate together in a single heating system.
2. Parallel Modulation fires as many boilers as possible to maximize system efficiency.
3. The Auto rotation function rotates the lead boiler every time a call for heat is received when a Thermostat option is chosen in CH Demand or every 24 hours when a Constant option is chosen in CH Demand.

8.2. Cascade Algorithm

8.2.1 Boiler Enabling Algorithm

The Master boiler uses the following algorithm to determine when the next boiler can be enabled:

$$\frac{\text{Number of Boilers Firing} + 1}{\text{Number of Boilers Firing}} \times \text{Min. Firing Rate} = \text{Individual Boiler Firing Rate}$$

Once the currently fired boilers reach the calculated firing rate, the next boiler can be enabled without affecting the overall cascade firing rate.

For example, the calculation for a Cascade System consisting of two GALLANT 399s would be:

$$\frac{1+1}{1} \times 25\% = 50\%$$

Once the first GALLANT 399 firing rate reaches 50%, the second GALLANT 399 can be enabled. Both will then fire at the minimum 25% firing rate so that the overall output from the Cascade System remains the same.

8.2.2 Boiler Disabling Algorithm

Once the firing rate of all currently fired boilers decreases to the Minimum Firing Rate, a boiler can be disabled. The boilers which continue to fire will increase their firing rate if required to replace the output of the disabled boiler.

Stable cascade operation requires that all boilers in a Cascade System be the same size. Mixing boiler sizes in a Cascade System could lead to temperature fluctuations and erratic cascade operation.

8.3. CTRLMax Cascade menu structure

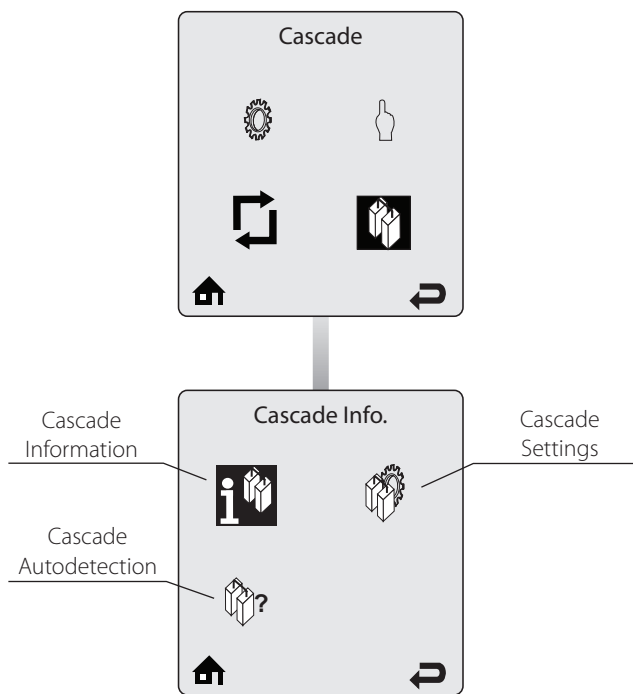

8.4. Cascade Installation

8.4.1 System Piping

Standard Cascade installations will utilize a balanced manifold system as the primary / secondary connection to the system piping as shown in *Fig. 27 on page 68* or a reverse return piping arrangement as shown in *Fig. 31 on page 72*.

Split Cascade installations will utilize a balanced manifold system as the primary / secondary connection to the central heating loop. Each boiler configured to respond to a domestic hot water call will also have a direct connection to the indirect water heater as shown in *Fig. 29 on page 70*. Reference the boiler Installation and Maintenance Manual for general boiler installation and piping requirements.

8.4.2 System Sensor Installation

Cascade operation requires a System Temperature Sensor to be installed on the common supply header downstream of all boilers in the system.

Place the System Temperature Sensor within 10' of the last boiler in the Cascade System for an accurate temperature reading. Proper placement and installation of

the System Temperature Sensor is critical for reliable cascade operation. The type of System Temperature Sensor chosen also greatly affects the accuracy of the system temperature readings.

Three types of System Temperature Sensor are available:

- **Direct Immersion** - A direct immersion temperature sensor (MDRKIT05) is the recommended type since it will provide the most accurate water temperature readings. Install the 1/2" NPT direct immersion temperature sensor in a tee on the common supply header downstream of all boilers in the system. Ensure that the temperature sensor probe is directly in the water flow but not touching the opposite side of the tee. Wire the sensor to terminals 3 & 4 of X5 on the control module of the Master boiler.
- **Dry Well Installation** - A temperature sensor (PSRKIT22) installed in a dry well will measure up to 10°F [5°C] lower than the actual water temperature. All water setpoints must be lowered at the Master boiler by 10°F [5°C] from the desired setpoints for reliable Cascade operation. Install a 3/8" ID drywell in the common supply header downstream of all boilers in the system. The drywell should be long enough to be directly in the water flow for the most accurate temperature reading. Insert the temperature sensor into the well and wire to terminals 3 & 4 of X5 on the control module of the Master boiler.
- **Pipe Mounted Installation** - A temperature sensor (PTSENS12) mounted to the outside of the pipe will measure up to 20°F [11°C] lower than the actual water temperature. All water setpoints must be lowered at the Master boiler by 20°F [11°C] from the desired setpoints for reliable Cascade operation. The Pipe Mounted temperature sensor can be directly strapped to the outside of a 1" to 3" metallic pipe.

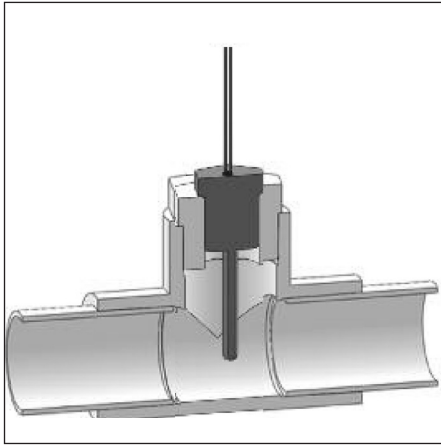

Fig. 24 - System Sensor Direct Immersion

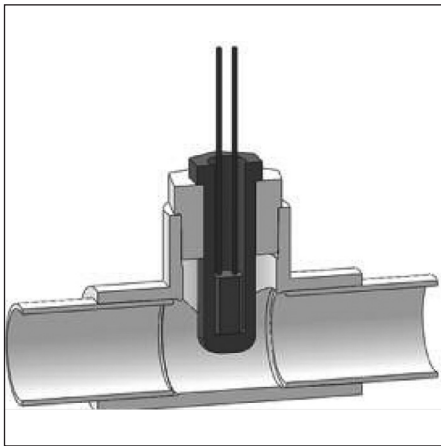

Fig. 25 - System Sensor Dry well Installation

Install the temperature sensor as follows:

1. Remove the white plastic cover from the sensor
2. Cut a small slit in the gasket seal on the end of the sensor.
3. Route 18 AWG 2-wire cable or similar cable through the seal gasket into the enclosure.
4. Push down on the orange wire terminal retainers to insert the wires into the sensor terminals. Release the orange wire terminal retainers and confirm that the wires are firmly attached to the sensor terminals.
5. Select a location for the sensor on the common supply header downstream of all boilers in the system. Clean the pipe with fine sandpaper or emery cloth to ensure the pipe is clean and sensor will make good contact with the pipe.
6. Actuate the white cover onto the sensor and strap the sensor to the pipe using the included wire tie.
7. Wire the sensor to terminals 3 & 4 of X5 on the control module of the Master boiler.

8.4.3 Cascade Communication Cable

A communication cable PACAB01 must be installed between each boiler in the Cascade System. The cable has a 4 pin molex connector on one end and a 6 pin molex connector on the other end. The 4 pin molex connector plugs into the Cascade Master X16 connector on the control module of the Master boiler or prior Slave boiler in cascades of three or more boilers. The 6 pin molex connector plugs into the Cascade Slave connector of the Slave boiler. Reference *Fig. 28 on page 69*, *Fig. 32 on page 73* and *Fig. 30 on page 71* for wiring details.

8.4.4 Low Voltage Wiring Connections

- **Thermostat Wiring** – CH1 and CH2 calls must be wired into the Cascade Master.
- **Outdoor Sensor Wiring** – The outdoor temperature sensor must be wired into the Cascade Master.
- **Domestic Hot Water Wiring** – A DHW call must be wired into the Cascade Master.
- **Additional Boiler Limits** – Boiler Limits must be wired into each boiler in the Cascade System. When a boiler limit opens, that particular boiler will lockout and will be removed from Cascade System operation. The other boilers in the Cascade System will continue to operate if they are not in a lockout.
- **External Modulation Control** – An External Modulation Signal must be wired into the Cascade Master. The modulation signal will control the firing rate of the entire Cascade System, not just the Cascade Master.
- **Modbus Wiring** – A building management system (BMS) connection must be wired into the Cascade Master to obtain cascade system and Master boiler information.

8.4.5 Line Voltage Wiring Connections

- **Circulator Wiring** - Reference *Figures 22, 24 and 26 on pages 58, 60 and 62* for circulator wiring required for each type of Cascade System. The circulator connections used will depend on the systems piping layout. All circulators are powered from a common 5A fuse located on the control module. The total combined amp draw of the all circulators must not exceed 5 amps at any time. Use an isolation relay to lower the total combined amp draw if exceeding this limits.
- **Power Supply** – A dedicated 120 VAC / 15A minimum service must be used to power the boilers in the Cascade System. Multiple boilers in the Cascade System can be placed on the same electrical circuit. Each boiler can draw a maximum of 8 amps.
- **Alarm Wiring** – The alarm contact closes whenever that particular boiler is in a condition set by the Error Relay Setting. The alarm contact will also close on the Master boiler when any of the Slave boilers are locked in a condition set by the Error Relay setting.

8.4.6 Cascade Autodetection

The Cascade System must be configured after wiring is completed and any required adjustments are made in Cascade Settings. The Cascade Autodetection function automatically finds and configures all boilers in the Cascade System. This eliminates the need to manually configure each boiler of the Cascade System. Select Cascade Autodetection on the Master boiler then follow the on-screen instructions to perform Cascade Autodetection. Once Cascade Autodetection is finished, a message will be displayed indicating how many boilers have been found. If the number of boilers found is correct, press OK to finish Cascade Autodetection. If the number of boilers found is not correct, check the cascade communication cables between the boilers and repeat Cascade Autodetection. See navigation on next page.

8.4.7 Lockouts

If a lockout occurs to a boiler in a Cascade System, it will be removed from Cascade System operation. The remainder of the Cascade System continues to operate and the next available boiler will fire if necessary. The Lockout Screen will be displayed on the locked out boiler as well as the Master boiler. The Master boiler Lockout Screen will also indicate which boiler in the Cascade System is locked out. See *Fig. 20 below*.

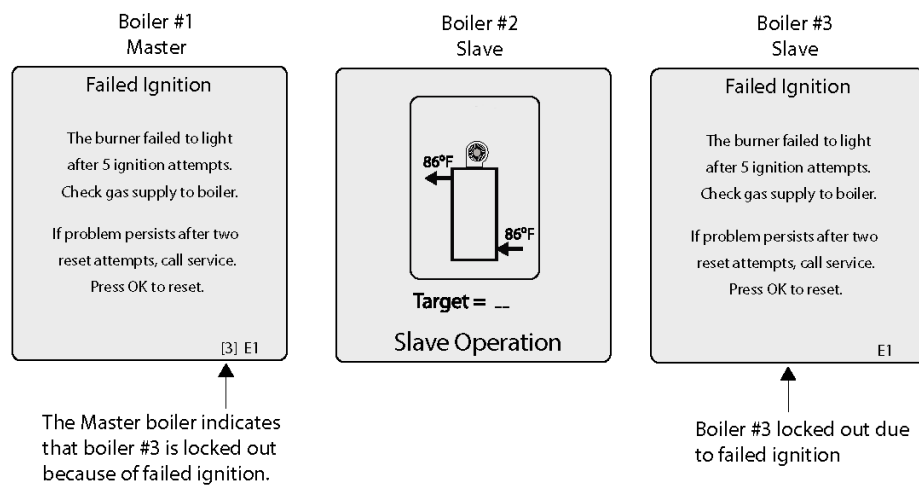
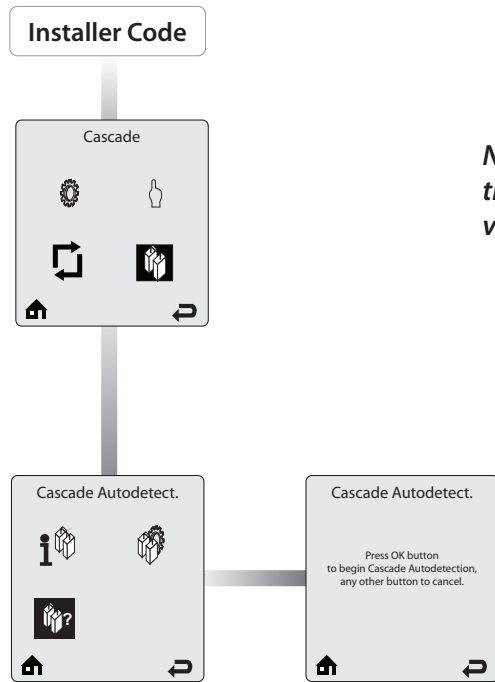

Fig. 26 - Lockouts in a cascade



NOTICE

Navigate on the screen using the UP, DOWN, LEFT and RIGHT keys, then the validate a selection with the OK key. To increase/decrease values, use the UP and DOWN or LEFT and RIGHT keys, according to the situation and validate with OK.

 **The Cascade System must be configured after wiring is completed and any required adjustments are made in Cascade Settings.**

The **Cascade Autodetection** function automatically finds and configures all boilers in the Cascade System. This eliminates the need to manually configure each boiler of the Cascade System. Select Cascade Autodetection on the Master boiler then follow the on-screen instructions to perform Cascade Autodetection.

Once **Cascade Autodetection** is finished, a message will be displayed indicating how many boilers have been found. If the number of boilers found is correct, press **OK** to finish Cascade Autodetection.

If the number of boilers found is not correct, check the cascade communication cables between the boilers and repeat **Cascade Autodetection** process.

CHAPTER 8 - CASCADE

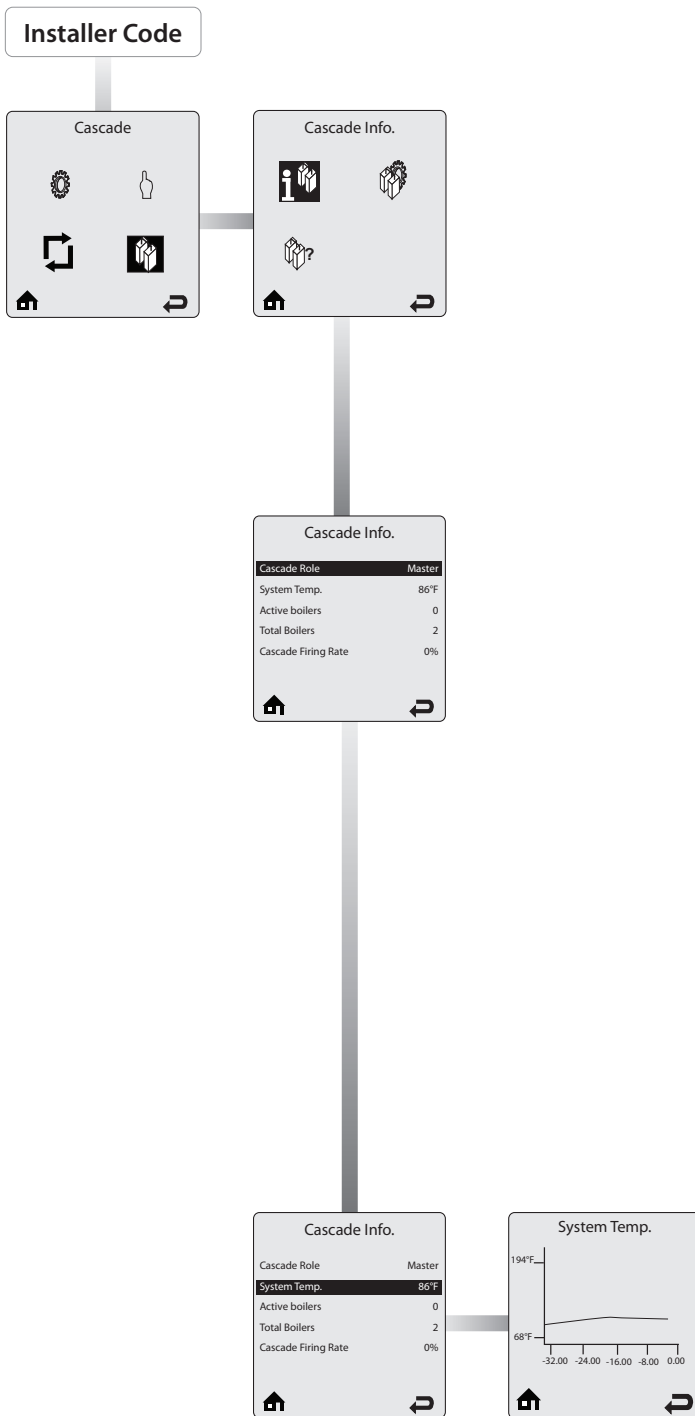

Cascade Info provides real time operating information of the Cascade System. Each line contains an information item followed by its current value.

Cascade Info provides the following information item:

- **Cascade Role** - Displays the current role of the appliance in the Cascade System. Cascade Role will be one of the following:
 - **Master** – Indicates this appliance is the Master boiler in the Cascade System.
 - **Slave** – Indicates this appliance is a Slave boiler in the Cascade System.
 - **Standalone** – Indicates this appliance is not part of a Cascade System.
- **System Temp** - See description below.
- **Active boilers** - Displays the current number of boilers fired in the Cascade System
- **Total Boilers** - Displays the total number of boilers in the Cascade System.
- **Cascade Firing Rate** - Displays the current firing rate of the entire Cascade System.

System Temp. - Displays the current system temperature reading on the Master boiler. If the system sensor is not wired in to the Master boiler, the Master boiler supply temperature is displayed. It has a logging function which records one sample every 12 minutes to produce a graph of the last 24 hours.

Select **System Temp.** in Cascade Info. then actuate the **OK** key to view the graph.

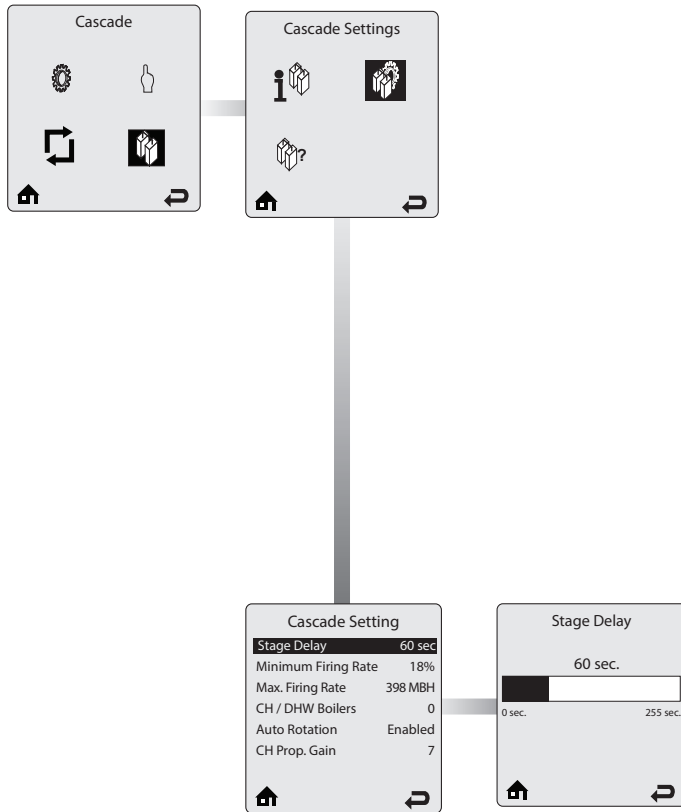

The **Cascade Settings** menu contains settings related to cascade operation. Each line contains a Cascade Setting followed by its current value. Six Cascade Settings are displayed on the screen at one time.

Scroll through Cascade Settings using the **UP** or **DOWN** keys.

i **Cascade Setting changes must be made on the cascade Master. Cascade autodetection must be performed after making any changes to a cascade Setting before the change will take effect.**

Stage Delay sets the time delay before enabling or disabling a boiler in the Cascade System. The Stage Delay begins once the Master boiler determines that a boiler must be enabled to reach the setpoint or when the Master boiler determines a boiler should be disabled because of a decreasing load.

Adjust the Stage Delay duration using the **LEFT** or **RIGHT** keys, then store the setting with the **OK** key.

Adjusting the Stage Delay will have the following effects:

- **Increasing Stage delay**
 - Reaching the setpoint could take longer due to a longer delay between enabling boilers.
 - Overshooting the setpoint could occur due to boilers staying on longer before being disabled.
- **Decreasing Stage delay**
 - Overshooting the setpoint could occur due to boilers being enabled quicker.
 - Boilers will be disabled quicker, possibly increasing boiler cycling and decreasing runtimes.



Minimum Firing Rate is the minimum firing rate of a single boiler in the Cascade System. The Master boiler uses this setting to determine when boilers can be enabled and disabled.

Setting the Minimum Firing Rate below the recommended minimum will result in boilers being enabled too quickly which may cause sharp increases in temperature from the Cascade System. Setting the Minimum Firing Rate above the recommended minimum will delay the enabling of boilers which may lower the system efficiency. For more information on the algorithm behind the cascade operation, refer to *Section 8.2 on page 55*.

Adjust the Minimum Firing Rate using the **LEFT** or **RIGHT** keys, then store the setting with the **OK** key.

Default : 18%

NOTICE

Only make changes after being instructed to do so by Ideal as changing of this value may cause instability in the appliance cascade control.

NOTICE

Stable cascade operation requires that all boilers in a Cascade System be the same size. Mixing boiler sizes in a Cascade System could lead to temperature fluctuations and erratic cascade operation.

Maximum Firing Rate is the maximum capacity of a single boiler in the Cascade System.

Adjust the Maximum Firing Rate using the **LEFT** or **RIGHT** keys, then store the setting with the **OK** key.

This value, expressed in MBH, will correspond to the current appliance range.

Default: according to the boilers

Model	Min. Firing Rate	Max. Firing Rate
GALLANT 250	18%	240 MBH
GALLANT 299	18%	299 MBH
GALLANT 399	18%	399 MBH
EXALT Heat Only/Combi 155	18%	155 MBH
EXALT Combi 199	18%	199 MBH

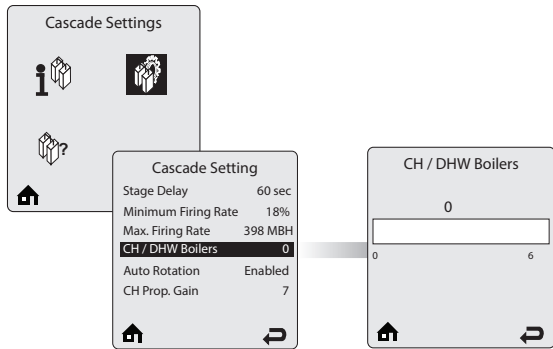

The **CH / DHW Boilers** setting specifies how many boilers in a Split Cascade System will respond to a domestic hot water call.

The **CH / DHW Boilers** always include the Master boiler. The remaining boilers will only respond to central heating calls. This allows the Cascade System to satisfy both central heating and domestic hot water calls at the same time. At the completion of a domestic hot water call, the CH or DHW Boilers will again be available to respond to central heating calls.

Adjust the CH/DHW Boilers number using the **LEFT** or **RIGHT** keys, then store the setting with the **OK** key.

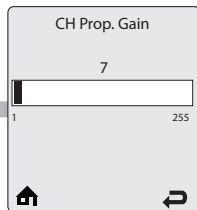
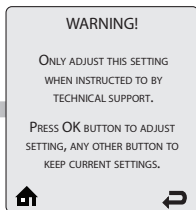
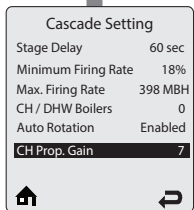
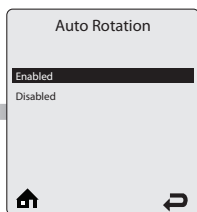
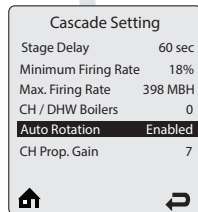
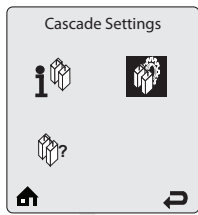

Through the **Auto Rotation** function, the number of burning hours is equalized over all appliances.

When the function is **Enabled**, the appliances will all run an equal amount of time. This helps balancing wear over the appliances.

When the function is **Disabled**, there is no leveling of burning hours and the first appliances in the sequence will run more than the last one in the sequence.

Select *Enabled* or *Disabled* using the **UP** or **DOWN** keys, then store the setting with the **OK** key.

CH Proportional Gain allows the cascade response to be adjusted for a central heating call. CH Proportional Gain has the greatest influence when the system temperature is far away from the setpoint.

Adjust the CH Prop. Gain value using the **LEFT** or **RIGHT** keys, then store the setting with the **OK** key.

• Increase CH Proportional Gain

- The Cascade System will reach setpoint faster, but overshooting the setpoint may occur.
- To reach the setpoint faster, increase the CH Proportional Gain value by 2. Perform Cascade Autodetection and initiate a central heating call. Observe the cascade response and make further adjustments if necessary..

• Decrease CH Proportional Gain

- The Cascade System will take longer to reach the setpoint, but setpoint overshooting is minimized.
- If the setpoint is reached too quickly, decrease the CH Proportional Gain value by 2. Perform Cascade Autodetection and initiate a central heating call. Observe the cascade response and make further adjustments if necessary

Default: 7

NOTICE

Please consult Ideal's technical Support before making any adjustments. Improper adjustment of CH Proportional Gain could lead to temperature fluctuations and erratic cascade operation.

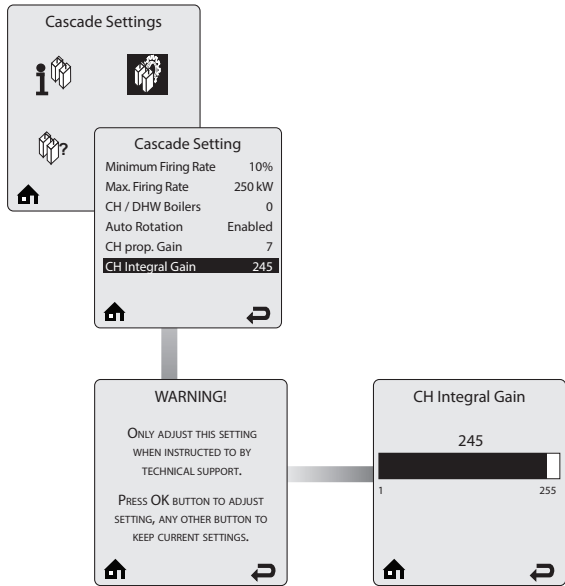

CH Integral Gain allows the cascade response to be adjusted for a central heating call. CH Integral Gain has the greatest influence when the system temperature is close to the setpoint.

Adjust the CH Integral Gain value using the **LEFT** or **RIGHT** keys, then store the setting with the **OK** key.

• **Increase CH Integral Gain**

- The Cascade System will take longer to reach the setpoint, but setpoint overshooting is minimized.
- If the setpoint is reached too quickly, increase the CH Integral Gain value by 2. Perform Cascade Autodetection and initiate a central heating call. Observe the cascade response and make further adjustments if necessary.

• **Decrease CH Integral Gain**

- The Cascade System will reach setpoint faster, but overshooting the setpoint may occur.
- To reach the setpoint faster, decrease the CH Integral Gain value by 2. Perform Cascade Autodetection and initiate a central heating call. Observe the cascade response and make further adjustments if necessary.

Default: 245

NOTICE

Please consult Ideal's technical Support before making any adjustments. Improper adjustment of CH Integral Gain could lead to temperature fluctuations and erratic cascade operation.

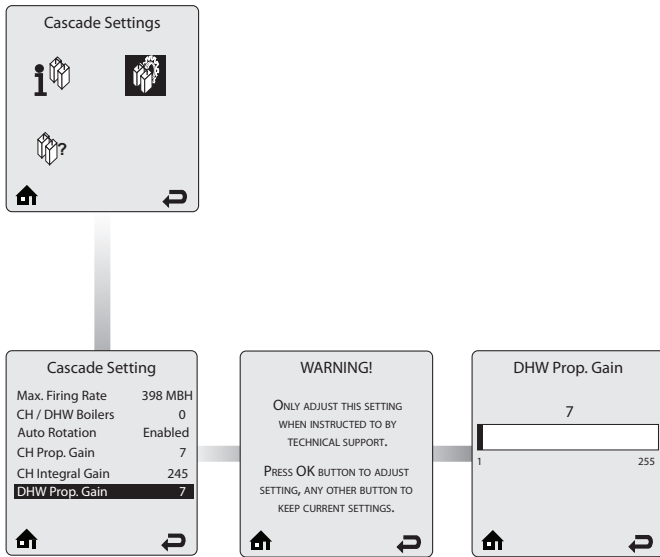

DHW Proportional Gain allows the cascade response to be adjusted for a domestic hot water call. DHW Proportional Gain has the greatest influence when the system temperature is far away from the setpoint.

Adjust the DHW Prop. Gain value using the **LEFT** or **RIGHT** keys, then store the setting with the **OK** key.

• **Increase DHW Proportional Gain**

- The Cascade System will reach setpoint faster, but overshooting the setpoint may occur.
- To reach the setpoint faster, increase the DHW Proportional Gain value by 2. Perform Cascade Autodetection and initiate a domestic hot water call. Observe the cascade response and make further adjustments if necessary.

• **Decrease DHW Proportional Gain**

- The Cascade System will take longer to reach the setpoint, but setpoint overshooting is minimized.
- If the setpoint is reached too quickly, decrease the DHW Proportional Gain value by 2. Perform Cascade Autodetection and initiate a domestic hot water call. Observe the cascade response and make further adjustments if necessary.

Default: 7

NOTICE

Please consult Ideal's technical Support before making any adjustments. Improper adjustment of DHW Proportional Gain could lead to temperature fluctuations and erratic cascade operation.

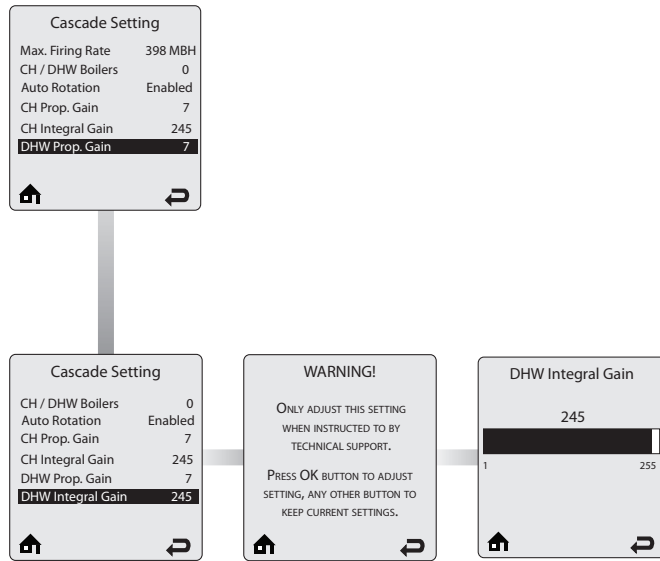

DHW Integral Gain allows the cascade response to be adjusted for a domestic hot water call. DHW Integral Gain has the greatest influence when the system temperature is close to the setpoint.

Adjust the DHW Integral Gain value using the **LEFT** or **RIGHT** keys, then store the setting with the **OK** key.

- **Increase DHW Integral Gain**
 - The Cascade System will take longer to reach the setpoint, but setpoint overshooting is minimized.
 - If the setpoint is reached too quickly, increase the DHW Integral Gain value by 2. Perform Cascade Autodetection and initiate a domestic hot water call. Observe the cascade response and make further adjustments if necessary.
- **Decrease DHW Integral Gain**
 - The Cascade System will reach setpoint faster, but overshooting the setpoint may occur.
 - To reach the setpoint faster, decrease the DHW Integral Gain value by 2. Perform Cascade Autodetection and initiate a domestic hot water call. Observe the cascade response and make further adjustments if necessary.

Default: 245

NOTICE

Please consult Ideal's technical Support before making any adjustments. Improper adjustment of DHW Integral Gain could lead to temperature fluctuations and erratic cascade operation.

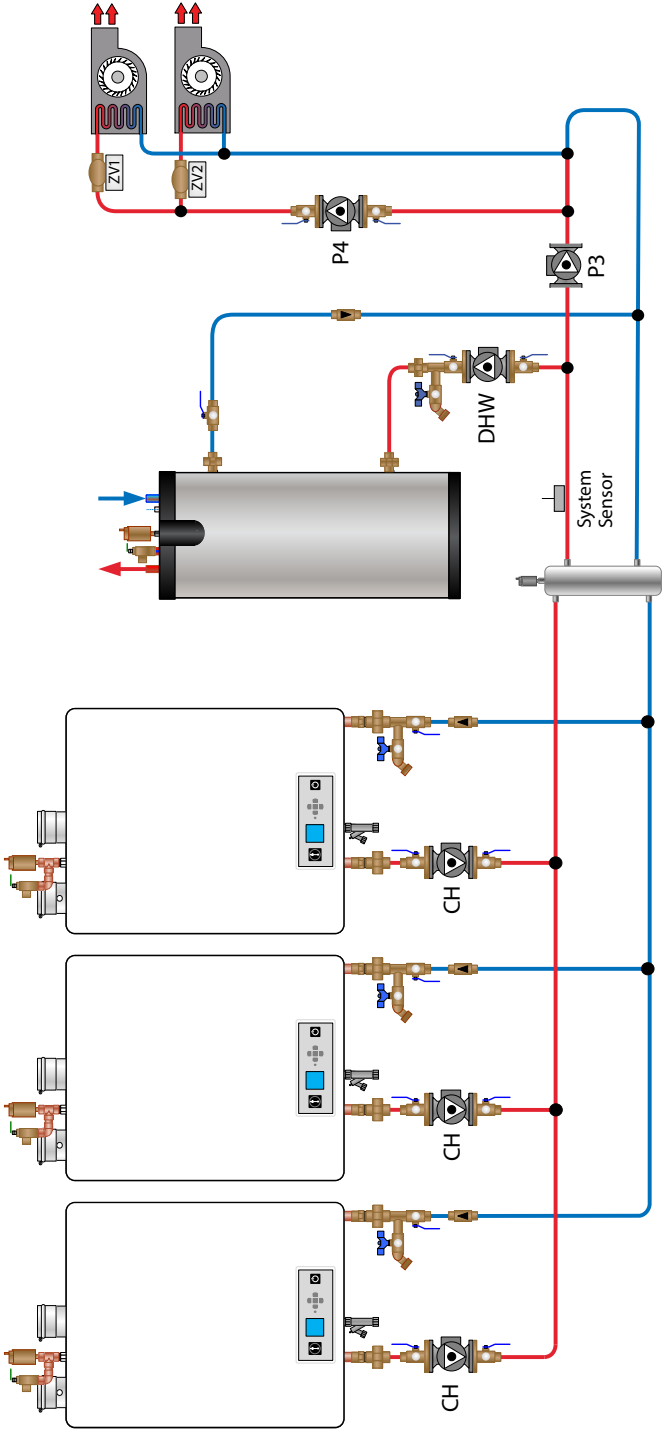

Fig. 27 - Primary Secondary Cascade Piping - GALLANT only

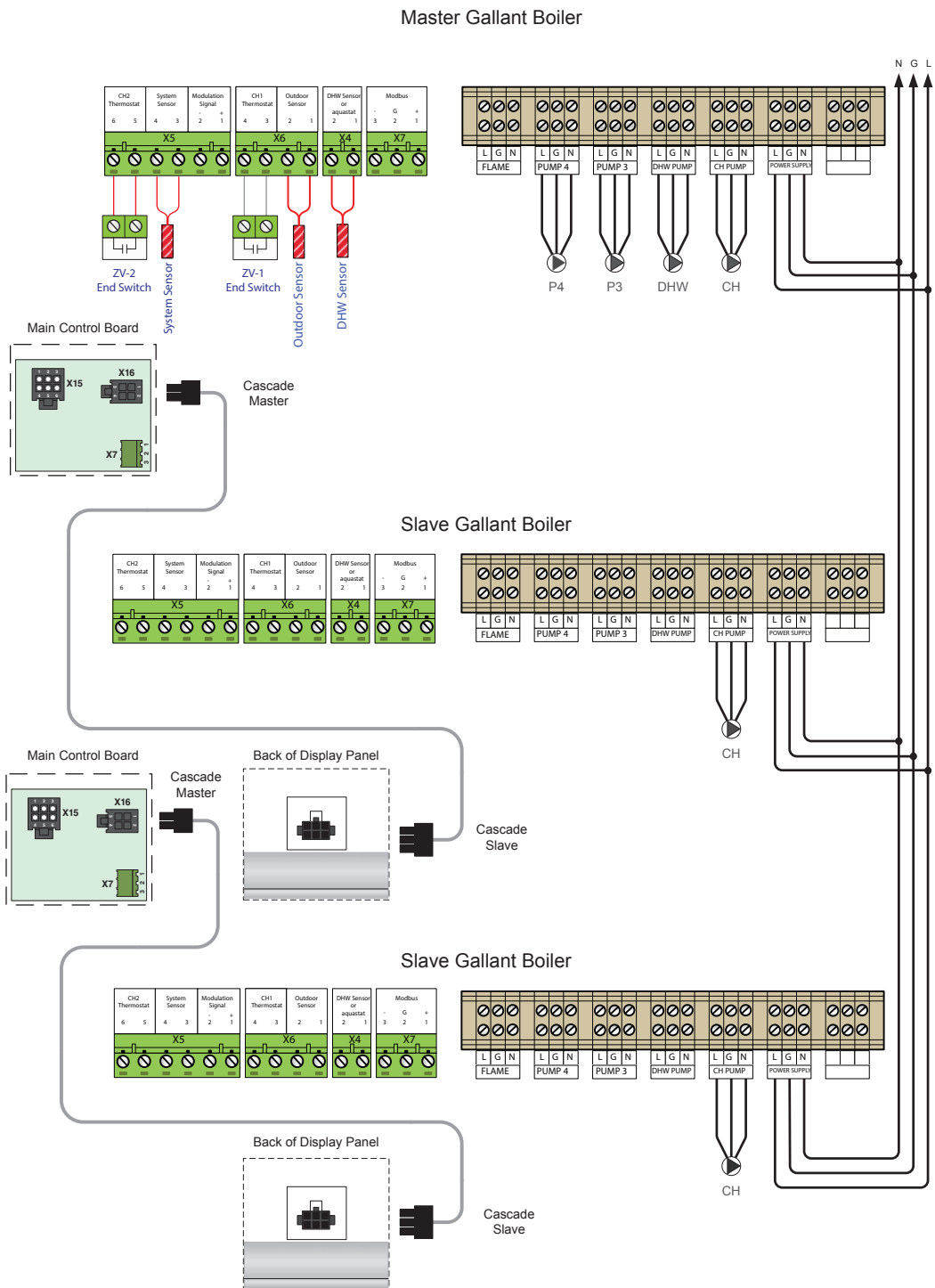

Fig. 28 - Primary Secondary Cascade Wiring - GALLANT Only

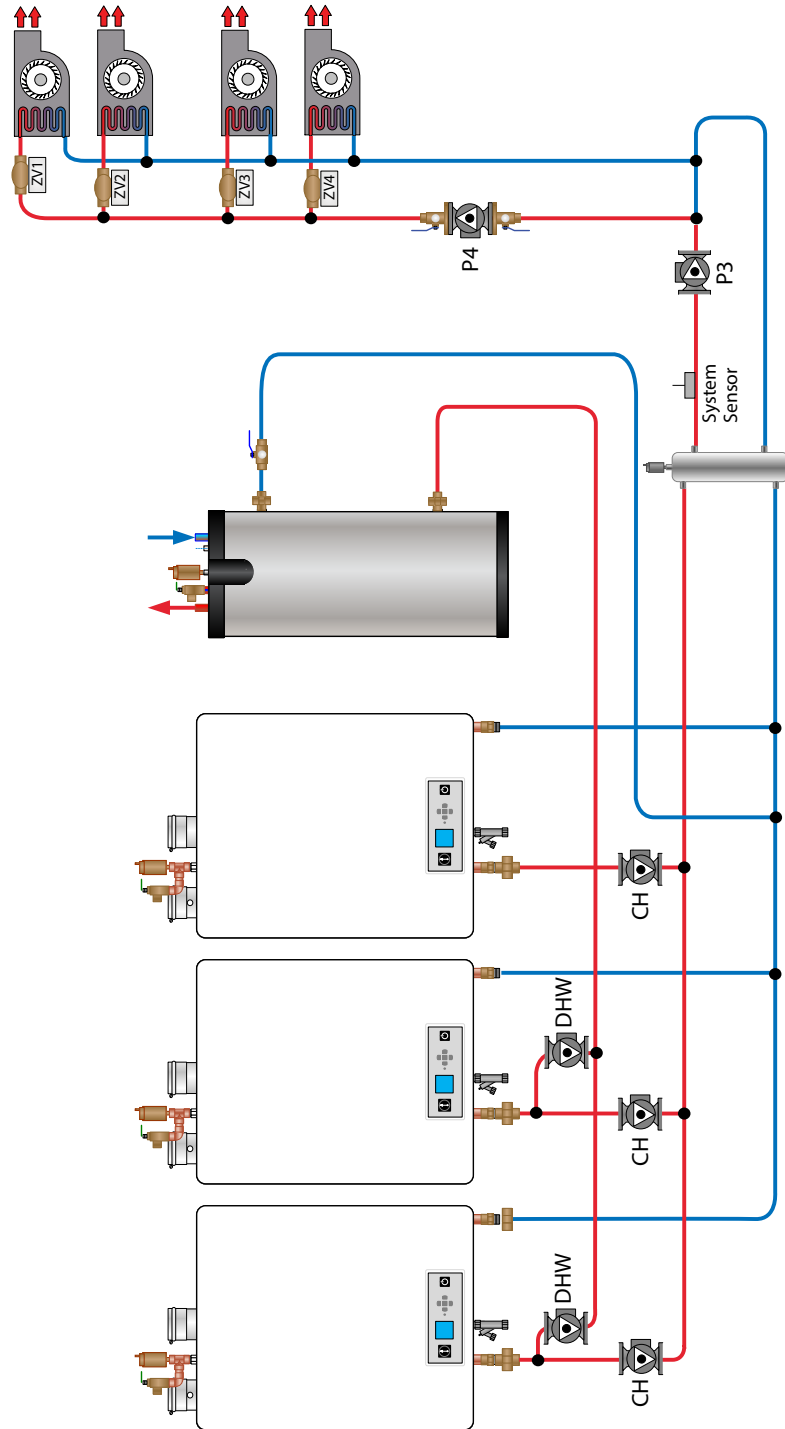

Fig. 29 - Split Cascade System - GALLANT Only

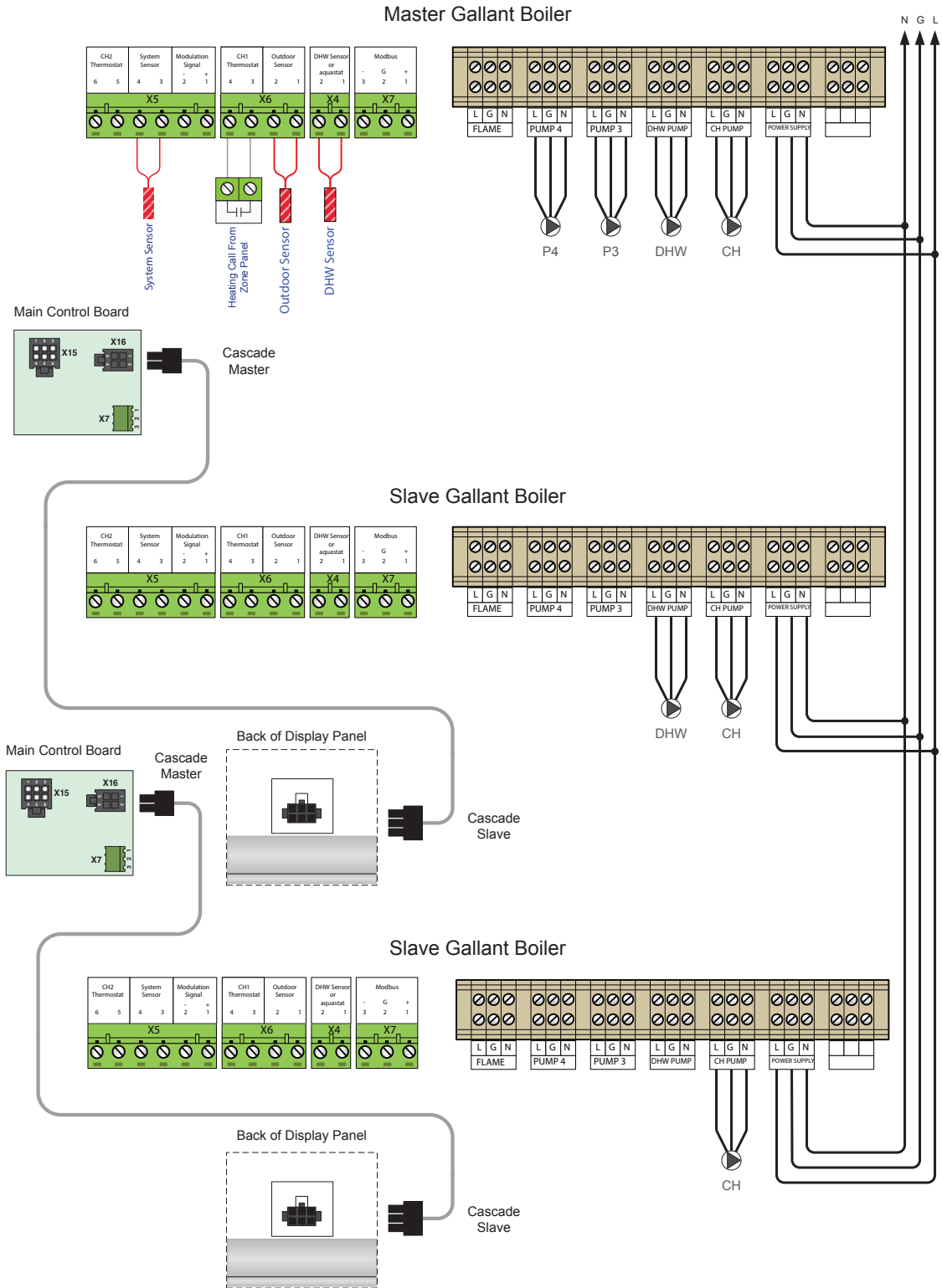

Fig. 30 - Split Cascade Wiring - GALLANT Only

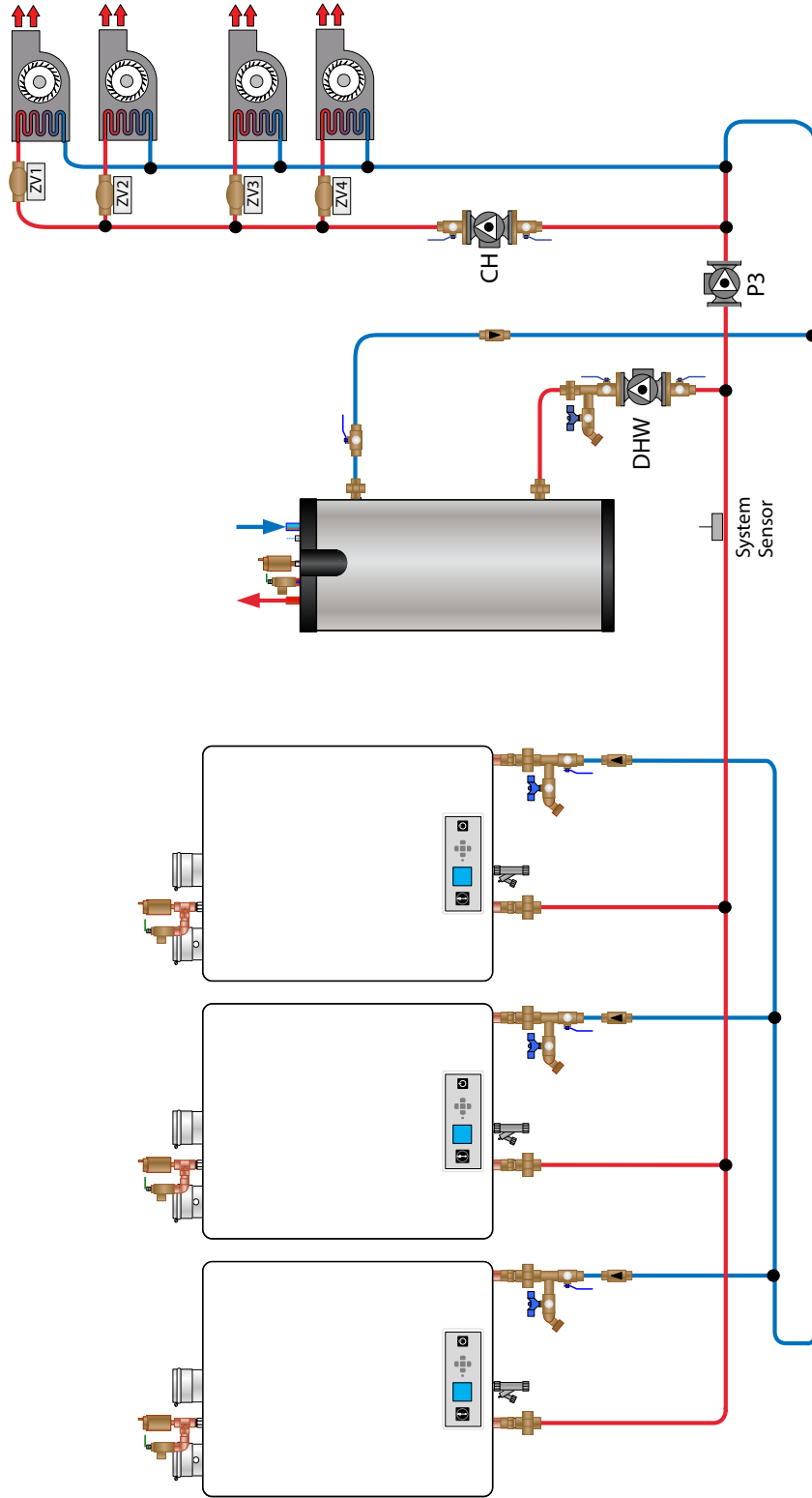

Fig. 31 - Reverse Return Cascade Piping - GALLANT

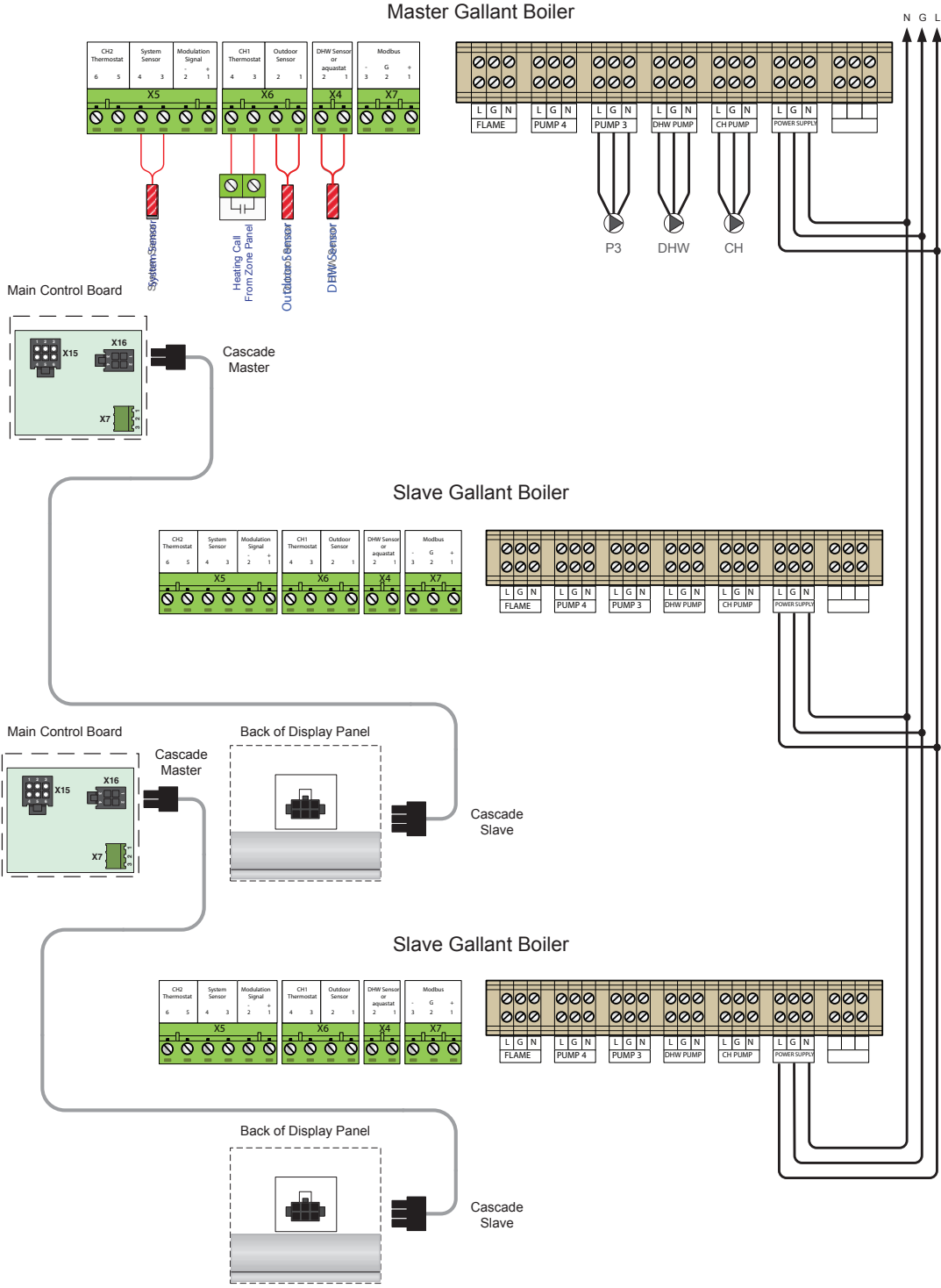

Fig. 32 - Reverse Return Cascade Wiring - GALLANT

NOTICE

To use this configuration, make sure to set up the pump configuration of each boiler in the cascade chain in order to get the correct outputs. Both "Preset Pump Config." and "Flexible Pump Config." functions can be used, depending on the system that is built. Contact Ideal's technical support for more information.

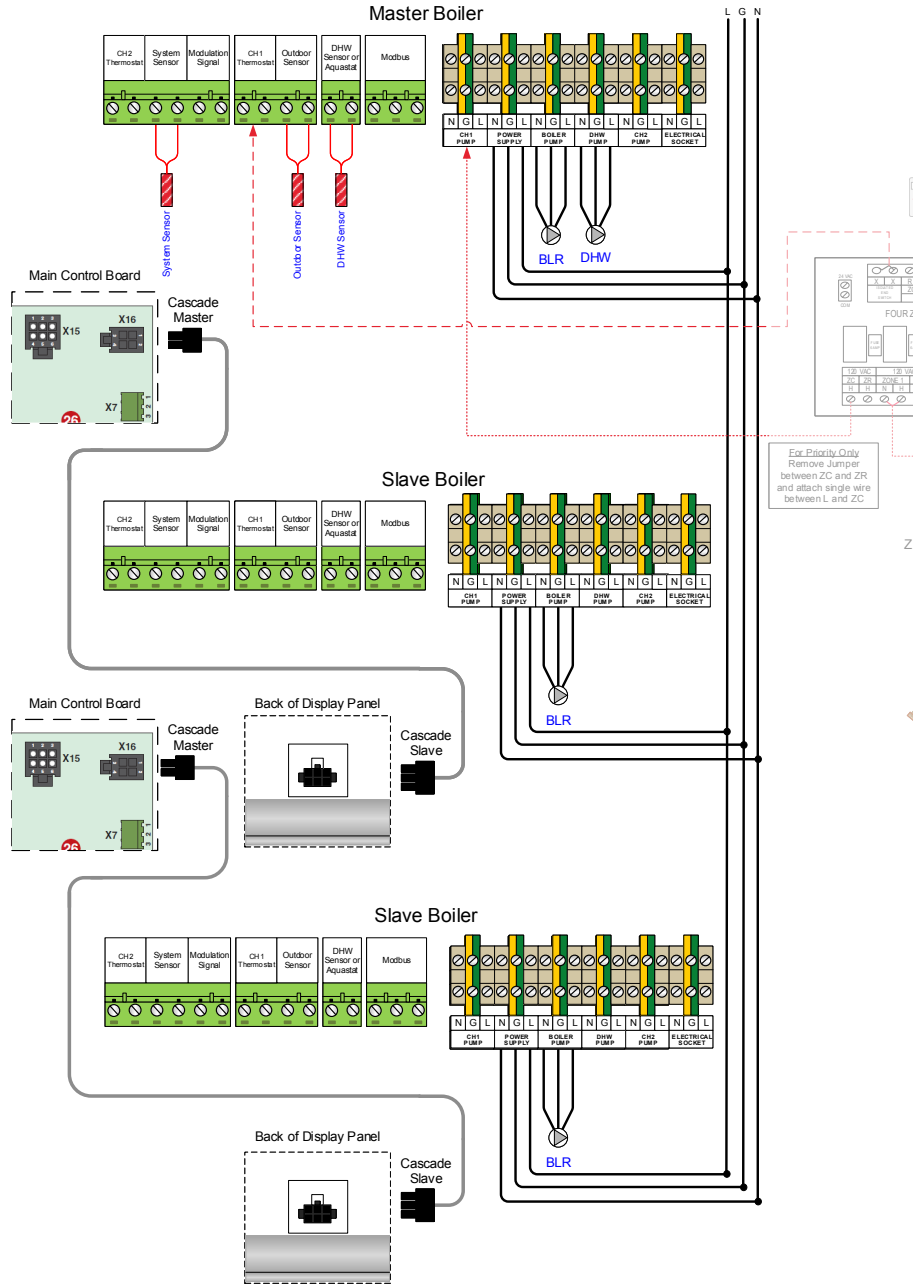

Fig. 33 - Reverse Return Cascade Wiring - EXALT Heat Only

INTENTIONALLY LEFT BLANK

CHAPTER 9 - MODBUS INTERFACE

The Modbus Interface allows a Building Management System (BMS) to directly connect to the appliance.

A BMS can read information from the boiler to determine its operating state, lockout status, sensor readings, etc. A BMS can also operate the boiler by providing a setpoint.

Table 2 - Modbus Configuration

Protocol	MODBUS RTU
Baud	Rate 38400bps
Data Length	8
Parity	None
Stop Bits	1
Physical Layer	RS485 (2 wire)

Table 3 - Supported Commands

DEC	HEX	Description
03	0x03	Read Holding Registers
04	0x04	Read Input Registers
06	0x06	Write Single Register
16	0x10	Write Multiple Registers
17	0x11	Report Slave ID

Table 4 - Holding Registers (Read/Write)

Address DEC (HEX)	Supported Commands	Description	Byte: Format	Notes
512 (0x0200)	0x03 0x06 0x10	CH Demand	MB:U8 LB:U8	<p>Writing 0= Modbus CH1 Demand has priority over a DHW call 255 = DHW call has priority over a Modbus CH1 Demand</p> <p>Reading 0 = No CH Calls Present 255 = CH1 or CH2 Call Present</p> <p>Writing 0 = End CH1 Demand 255= Begin CH1 Demand A CH1 Demand lasts for 30 seconds from the last successful write.</p>
513 (0x201)	0x03 0x06 0x10	Maximum Firing Rate	LB:U8	Value = Maximum Firing Rate % This register becomes active when 255 is written to register 512 (0x0200)
514 (0x202)	0x03 0x06 0x10	CH Setpoint	LB:U8	Value = CH Setpoint °C This register becomes active when 255 is written to register 512 (0x0200)
1280 (0x0500)	0x03	CH1 Maximum Setpoint	LB:U8	Value = °C
1281 (0x0501)	0x03	DHW Storage Setpoint	LB:U8	Value = °C

CHAPTER 9 - MODBUS INTERFACE

Table 5 - Input Registers (Read only)

Address DEC (HEX)	Supported Commands	Description	Byte: Format	Notes
0 (0x0000)	0x04	Boiler Status	LB: Flag8	Bit: Description 0: PC Manual Mode 1: DHW Mode 2: CH Mode 3: Freeze Protection Mode 4: Flame Present 5: CH(1) Pump 6: DHW Pump 7: System / CH2 Pump 0 = Off, 1 = On
1 (0x0001)	0x04	Lockout Status	MB: Flag8 LB:U8	Bit: Description 1: Lockout Code Type 0 = Automatic Reset Lockout 1 = Manual Reset Lockout Value = Lockout Code
2 (0x0002)	0x04	Lockout Status	LB:U8	0 = Single / Master Boiler 1 = Slave 1 2 = Slave 2 3 = Slave 3 4 = Slave 4 5 = Slave 5 F = Single / Master Display
768 (0x0300)	0x04	Boiler Supply Temperature / System Temperature	S16	Value = 0.1°C Invalid Value = 32768 (0x8000) Value is the Boiler Supply Temperature unless the System Temperature Sensor is installed
769 (0x0301)	0x04	Boiler Return Temperature	LB:S8	Value = °C Invalid Value = 65472 (0xFFC0)
770 (0x0302)	0x04	DHW Storage Temperature	LB:S8	Value = °C Invalid Value = 32768 (0x8000)
771 (0x0303)	0x04	Boiler Flue Temperature	LB:S8	Value = °C Invalid Value = 65472 (0xFFC0)
772 (0x0304)	0x04	Outdoor Temperature	LB:S8	Value = °C Invalid Value = 32768 (0x8000)
773 (0x0305)	0x04	Future Use	LB:U8	
774 (0x0306)	0x04	Flame Ionization Current	LB:U8	Value = Flame Current μ A
775 (0x0307)	0x04	Boiler / Cascade Firing Rate	LB:U8	Value = Firing Rate %
776 (0x0308)	0x04	Boiler Setpoint	LB:U8	Value = °C Invalid Value = 32768 (0x8000)



A series of horizontal dotted lines for writing, starting from the top right of the notepad illustration and extending across the width of the page.



Ideal Heating North America - 1240 Forest Parkway, Suite 100, West Deptford NJ 08066

Tel: (800) 411 9999 - Fax: (856) 228 3584 - E-mail: info@idealheatingna.com - Website: www.idealheatingna.com