

Geotechnical Product Range



**We make infrastructure
safer, stronger, and smarter.**

Contents

About DYWIDAG	3	DYWIDAG Rock bolts	23-25
Fields of application	4-5	DYWIDAG DYWI® Drill hollow bar system	26-32
DYWIDAG Threadbar anchors	6-8	DYWIDAG Stainless steel threadbar	33
DYWIDAG Strand anchors	9-10	DYWIDAG Stainless steel hollow bar	34-35
DYWIDAG Double corrosion protection ground anchor	11-12	DYWIDAG Tie bars - GEWI® and GEWI® Plus	36-40
DYWIDAG Smart anchor	13-14	Stressing and testing services	41-24
DYWIDAG GEWI® Pile system	15-18	Other products and services by DYWIDAG	43
DYWIDAG Threadbar soil nails	19-22		

Leading geotechnical solutions

At DYWIDAG, we stand as the UK's leading geotechnical supplier, offering a comprehensive range of ground engineering products coupled with unmatched expertise.

Globally recognised for our technical competence, quality assurance, and proven product reliability, DYWIDAG has firmly established its presence in the geotechnical ground and civil engineering sector across the globe.

We provide expert guidance to geotechnical drilling contractors and engineers across the UK. Our scope includes geotechnical solutions with specialised monitoring services and innovative concrete technology products.

With decades of experience in developing, producing, and supporting geotechnical projects, we assure our customers of consistently high-quality products and systems.

Our specialised technical services are tailored to meet the unique requirements of each project, whether it's enhancing technical efficiency or achieving cost-effectiveness. Our team is dedicated to helping you reach your project goals.

Our extensive range of geotechnical products includes ground anchors, double corrosion protection systems, prestressing steel threadbar, DYWIDAG GEWI® bar, DYWIDAG GEWI® Plus bar, DYWIDAG DYWI® Drill hollow bar, removable anchors, glass fibre reinforced plastic bar, stainless steel bar and large diameter tie bars.

Alongside our product range, we provide inspection, testing, tensioning and maintenance services as well as equipment hire.



04 Fields of application

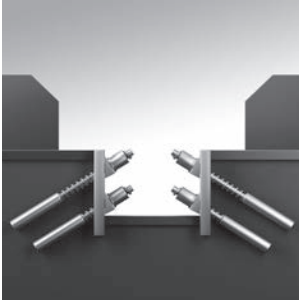

Excavations

Ground anchors play a crucial role in large and deep excavations, offering a cost-effective alternative to steel or concrete braces. They ensure safe construction, unrestricted access, and minimal obstruction.

- Bar and strand anchors.
- GEWI® Soil nails and rock bolts.
- DYWI® Drill soil nails and rock bolts.

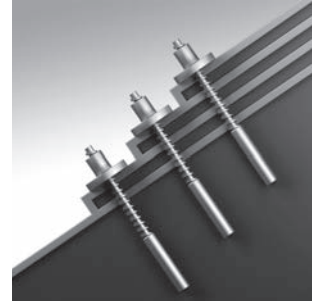
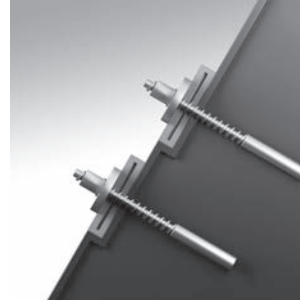

Slope stabilisation

Slope stabilisation is the process of reinforcing or securing the stability of slopes, hillsides, or embankments to prevent or mitigate potential landslides, erosion, or other slope failures.

- GEWI® Soil nails and rock bolts.
- DYWI® Drill soil nails and rock bolts.
- Bar and strand anchors.
- Mesh

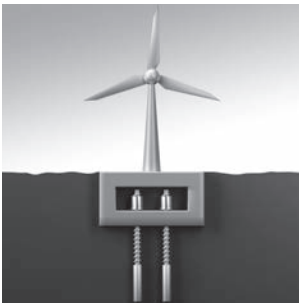

Foundations and underpinning

Micropiles provide stability and load transfer to individual and strip foundations, especially in challenging access areas. They enable quick and easy foundation reinforcement and load redistribution.

- GEWI® and GEWI® Plus piles.
- DYWI® Drill Hollow bar.

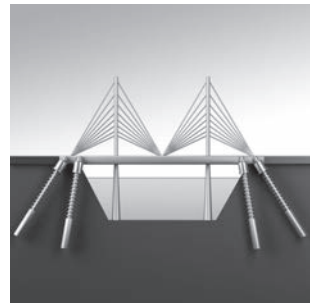
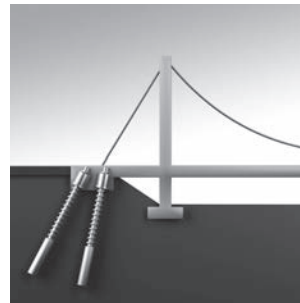

Anchoring of tensile loads

Ground anchors and tensile piles offer economical solutions for tying back tensile loads in various ground conditions. Large visible counterbalances or retaining structures can be eliminated because tensile loads are directly transferred into the ground.

- GEWI® and GEWI® Plus piles.
- DYWI® Drill tension piles.
- Bar and strand anchors.

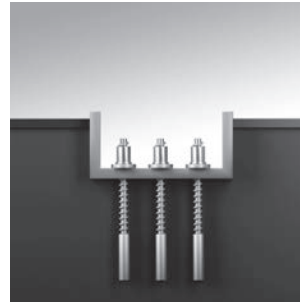
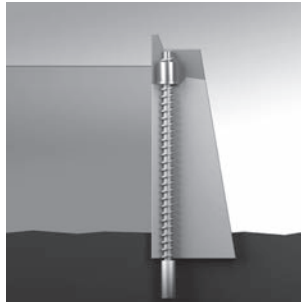
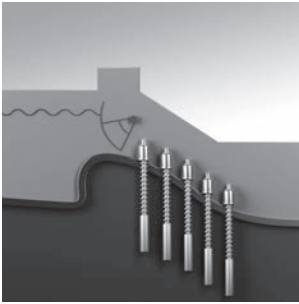

Dams

Anchoring techniques strengthen dam structures, providing stability in the face of changing water levels and load conditions.

- GEWI® soil nails and rock bolts.
- Bar and strand anchors.
- GEWI® and GEWI® Plus piles.
- Tie bars.

Uplift control

Tensile piles and tensioned anchors secure foundations against uplift, offering a time-efficient alternative to mass concrete.

- GEWI® and GEWI® Plus piles.
- Bar and strand ground anchors.
- DYWI® Drill tension piles.

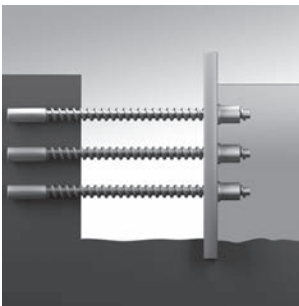

Tie bars and brace systems

Used for various structures primarily in construction and engineering projects in which two or more points of a structure need to be stabilised.

- GEWI®, GEWI® Plus and prestressing steel.
- Tie bars - large diameter bars and accessories.

Stability against overturning

Micropiles and ground anchors permanently stabilise structures at risk of tipping, providing flexibility and resilience in the face of external forces.

- Bar and strand anchors.
- GEWI® and GEWI® Plus piles.
- DYWI® Drill tension piles.

06 DYWIDAG Threadbar anchors

DYWIDAG Threadbar anchors are an active tensioned ground anchor system designed in compliance with the current BS8081 and EN1537 codes and standards.

Ground anchors are categorised as pre-stressed active systems with both bonded and free length section. The free length section serves to prevent the transfer of loads into unsuitable material, ensuring adequate elongation of the tendon for pre-stressing requirements.

In the bonded section, the anchor is securely fixed within the borehole using grout, facilitating the transfer of forces to the load-bearing ground through bond and skin friction.

Conversely, in the free length, the bar is uncoupled from the borehole via smooth sheathing, enabling unrestricted extension for tension application.

The anchor head facilitates force transfer to the substructure, thereby providing structural support. Monitoring of anchor forces can be achieved through the installation of load cells or via real-time monitoring utilising the smart anchor system, a specialised innovation by DYWIDAG.

Fields of application

- Excavation support.
- Tiebacks.
- Rock and slope stabilisation.
- Uplift restraint.
- Harbour and marine.
- Tunnelling.
- Bridges.

Key features

- **Versatility:** DYWIDAG Threadbar anchors provide versatility through their use of coarse GEWI®, GEWI® Plus and pre-stressed steel, thread along the entire length, enabling seamless on-site length adjustments with suitable accessories and equipment.
- **Active tensioning:** These anchors are actively tensioned, ensuring a reliable and secure connection to the ground or structure they support.
- **Bonded and free length sections:** Incorporates both bonded and free length sections, allowing for precise control over load transfer and elongation requirements.
- **Monitoring capabilities:** Enables the monitoring of anchor forces through load cells or real-time monitoring systems such as the DYWIDAG Smart anchor technology, allowing for proactive maintenance and ensuring long-term stability.
- **Ease of installation:** Threadbar anchors typically offer straightforward installation procedures, reducing construction time and labour costs.

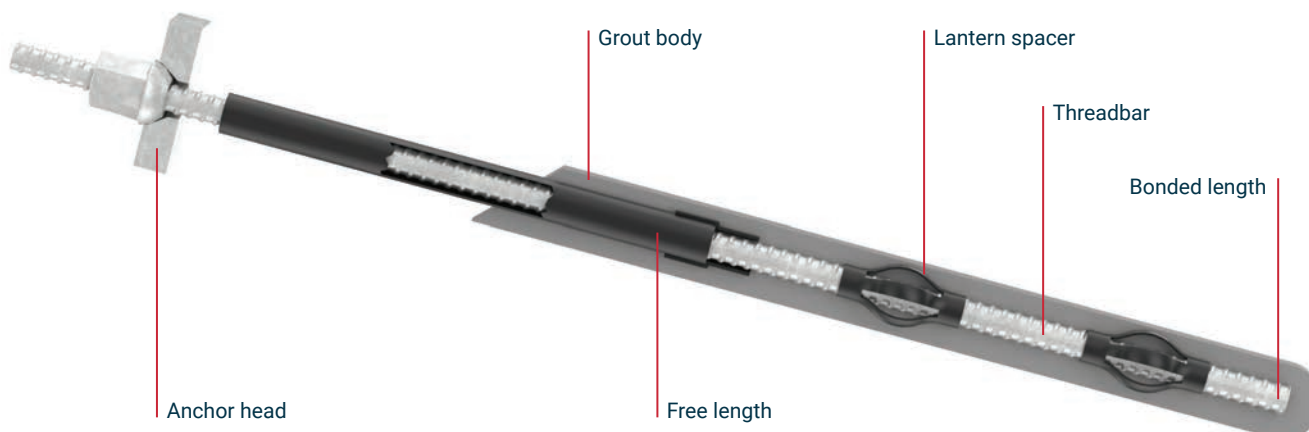

DYWIDAG Threadbar anchors

GEWI® Threadbar

Nominal diameter	Steel grade	Ultimate strength	Yield strength	Cross-sectional area	Diameter over threads	Thread pitch	Weight
[mm]	[N/mm ²]	[kN]	[kN]	[mm ²]	[mm]	[mm]	[kg/m]
16	500 / 600	121	101	201	18	8	1.58
20	500 / 600	188	157	314	23	10	2.47
25	500 / 600	295	246	491	28	12.5	3.85
28	500 / 600	370	308	616	32	14	4.83
32	500 / 600	482	402	804	36	16	6.31
36	500 / 600	612	510	1,020	40	18	7.99
40	500 / 600	754	629	1,257	45	20	9.86
50	500 / 600	1,178	982	1,963	55	26	15.41
57.5	555 / 700	1,818	1,441	2,597	63	20	20.38
63.5	555 / 700	2,217	1,758	3,167	69	21	24.66
75	500 / 600	2,651	2,209	4,418	82	24	34.68

GEWI® Plus Threadbar

Nominal diameter	Steel grade	Ultimate strength	Yield strength	Cross-sectional area	Diameter over threads	Thread pitch	Weight
[mm]	[N/mm ²]	[kN]	[kN]	[mm ²]	[mm]	[mm]	[kg/m]
18	670 / 800	203	170	254	21	8	2.00
22	670 / 800	304	255	380	25	8	2.98
25	670 / 800	393	329	491	28	10	3.85
28	670 / 800	493	413	616	32	11	4.83
30	670 / 800	566	474	707	34	11	5.55
35	670 / 800	770	645	962	40	14	7.55
43	670 / 800	1,162	973	1,452	48	17	11.40
50	670 / 800	1,570	1,315	1,963	56	18	15.40
57.5	670 / 800	2,078	1,740	2,597	63	20	20.38
63.5	670 / 800	2,534	2,122	3,167	69	21	24.86
75	670 / 800	3,534	2,960	4,418	82	24	34.68

Prestressing Steel Threadbar

Nominal diameter	Steel grade	Ultimate strength	Yield strength	Cross-sectional area	Diameter over threads	Thread pitch	Weight
[mm]	[N/mm ²]	[kN]	[kN]	[mm ²]	[mm]	[mm]	[kg/m]
15	900/1100	195	159	177	17	10	2.00
20	900/1100	345	283	314	23	10	2.56
26.5	950/1050	579	525	551	30	13	4.48
32	950/1050	845	760	804	36	16	6.53
36	950/1050	1,070	960	1,020	40	18	8.27
40	950/1050	1,320	1,190	1,257	45	20	10.21
47	950/1050	1,822	1,650	1,735	52	21	14.10
57	835/1035	2,671	2,155	2,581	64	21	20.95
65	835/1035	3,447	2,780	3,331	71	23	27.10
75	835/1035	4,572	3,690	4,418	82	24	35.90

08 Essential stabilisation works to prevent future erosion of the A40



Owner: Welsh Government

General contractor: Tarmac

Products supplied: 40mm GEWI® Threadbar double corrosion protection anchors

Railway embankment stabilisation



Owner: Network Rail

General contractor: Alun Griffiths

Products supplied: GEWI® Threadbar double corrosion protection anchors

DYWIDAG Strand anchors

Strand anchors, manufactured from flexible steel wire strands, are tailor-made and installed in a single continuous length, adhering to the BS8081 standard. Primarily utilised for anchor lengths surpassing 20 metres or when solid threadbars are impractical due to access limitations, they offer versatile solutions.

Supplied in coiled form to the site, these anchors can be unwound directly into boreholes, offering significant advantages, particularly in tunnel or basement projects.

Additionally, strand anchors address situations where anchor capacities exceed available threadbar strength ranges. With each 15.2mm compact strand having an ultimate load of 300kN, multiple strands can be integrated into an anchor.

The maximum number of strands utilised is determined by the installer's available stressing equipment. In conventional strand anchors, all strands originate and terminate at the same point.

Fields of application

- Retaining structures.
- Foundation support.
- Stabilisation.
- Excavations.
- Tunnels.
- Harbours and marine.
- Dam and reservoirs.
- Bridges.

Key features

- **High load capacity:** Strand anchors can support high loads, making them suitable for heavy-duty applications such as bridge construction, retaining walls, and deep foundation systems.
- **Versatility:** They can be used in a wide range of ground conditions, including soil, rock, and marine environments, offering flexibility in project design and execution.
- **Monitoring capabilities:** Strand anchor systems can allow for real-time monitoring of load and deformation, enabling proactive maintenance and ensuring structural safety over time.
- **Cost-effectiveness:** Despite their high load capacity and durability, strand anchors often offer cost-effective solutions compared to alternative methods, particularly in projects where the longer the strand length, the greater the economic advantage they offer over alternative methods.
- **Proven performance:** With decades of successful applications in various engineering projects worldwide, strand anchors have a proven track record of reliability and performance, instilling confidence in their use for critical infrastructure projects.

Temporary works strand anchor

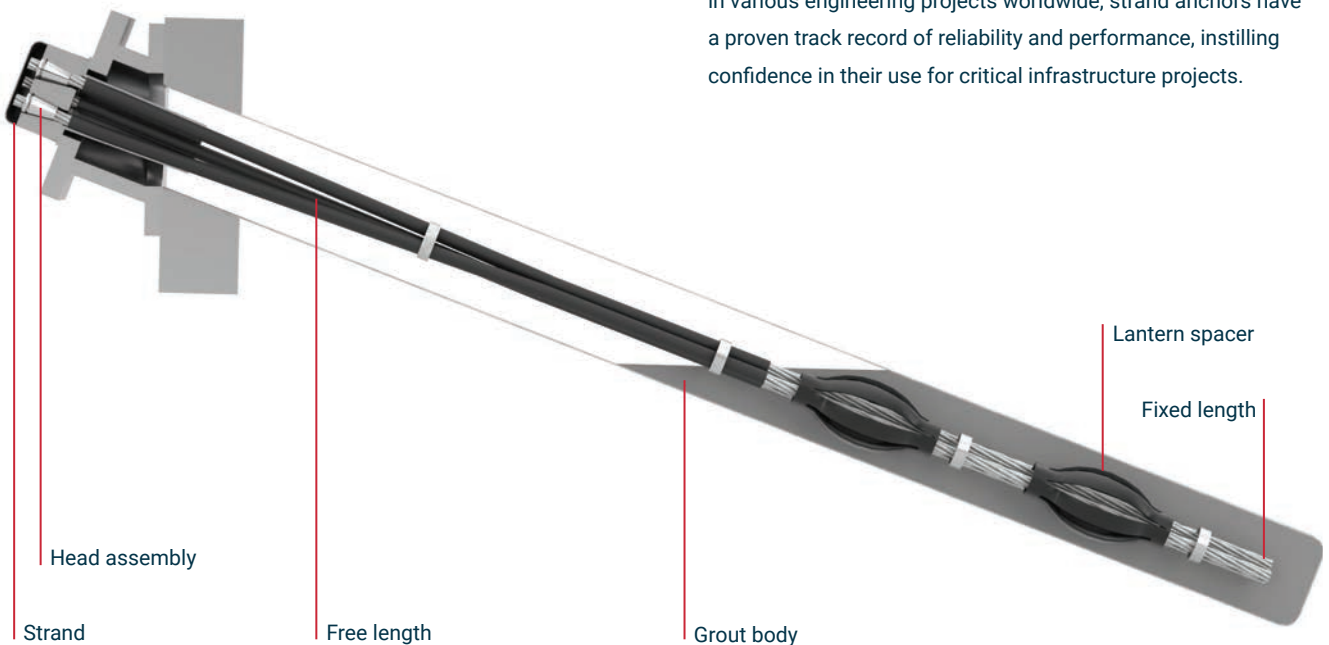

10 DYWIDAG Multi-stage strand anchors

The multi-stage strand anchor addresses the need for higher anchor loads in challenging ground conditions, overcoming limitations posed by conventional ground anchors, which are typically restricted to a maximum fixed length of 10m reference BS8081 and EN1537.

It ensures uniform load distribution across the entire bond length, enhancing stability in diverse soil types. This innovative solution employs a progressive anchoring mechanism, adapting dynamically to ground variations and minimising localised stress concentrations.

Its flexibility and reliability make it an ideal choice for stabilising embankments, retaining walls, and deep excavations.

Fields of application

- Retaining structures.
- Foundation support.
- Stabilisation.
- Excavations.
- Tunnels.
- Marine.
- Bridges.
- Pipeline installations.

Key features

- **Enhanced load capacity:** Designed to achieve higher anchor loads, surpassing conventional ground anchors, even in challenging ground conditions.
- **Uniform load distribution:** Ensures uniform distribution of load across the entire bond length, minimising localised stress concentrations and enhancing overall stability.
- **Progressive anchoring mechanism:** Utilises a staged approach to anchor installation, allowing for dynamic adaptation to ground variations and improved performance in diverse soil types.

Temporary works multi-stage stand anchor

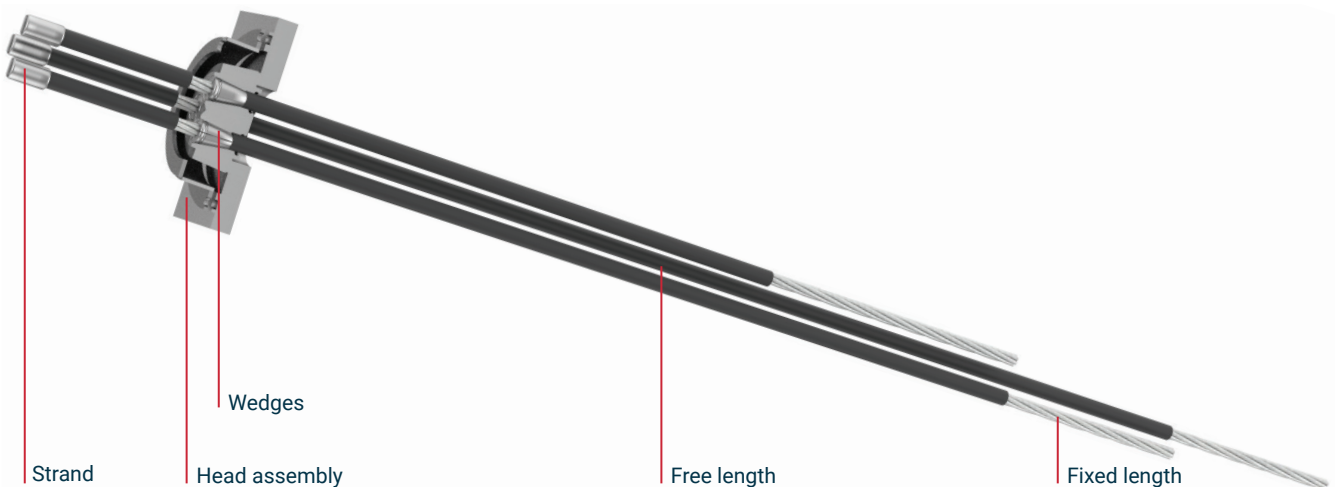

Double corrosion protection ground anchor

DYWIDAG double corrosion protection anchors are engineered to deliver reliable performance for up to 120 years according to BS8081 and EN1537.

To achieve this level of corrosion protection, BS8081 requires two impermeable barriers surrounding the steel tendon involving factory pre-grouted encapsulation of the bar or strand within a plastic sheath.

It's important to note that all double corrosion protection anchors undergo assembly and grouting in our manufacturing facility, rather than on-site, to ensure uninterrupted and contaminant-free adhesion and curing of the double corrosion protection.

Permanent anchors are installations designed to last over two years, requiring adequate corrosion protection measures. Borehole grout is not considered a corrosion protection barrier according to current anchor standards due to its vulnerability to contamination and potential inconsistency.

Fields of application

- Retaining structures.
- Foundation support.
- Stabilisation.
- Excavations.
- Tunnels.
- Marine.
- Mining.

Key features

- **Corrosion resistance:** Designed to withstand the effects of corrosion in harsh environments, providing long-term durability and reliability.
- **Dual protection:** They have dual layers of corrosion protection, such as factory pre-grouted encapsulation and specialised coatings.
- **High load capacity:** These anchors can support high loads, making them suitable for use in demanding applications where strength and stability are paramount.
- **Compliance:** They are manufactured in accordance with industry standards and regulations, ensuring compliance with safety and performance requirements.

Permanent bar anchor



Permanent strand anchor



Refer to our specialist data sheets.

DOUBLE CORROSION PROTECTION STRAND ANCHOR INSTALLATION



DYWIDAG Smart anchor

DYWIDAG Smart anchor is a plug-and-play integrated monitoring device that acquires, processes and alerts on real-time sensor data.

The overall solution provides an integrated view of the foundation condition of the structure.

Especially designed to fit threadbar anchors and strand anchors, the DYWIDAG Smart anchor is an anchor which feeds into a cloud-based platform, Infrastructure Intelligence.

Its load is monitored at frequent, regular intervals, by a unique force measurement sensor, and the field data provides access to analytics and reporting, so users can monitor a structure's performance remotely in real time from any connected device.

Key features

- Information can be shared via email and/or SMS alerts.
- Technology is secure and easily manageable from the Cloud.
- Delivers vital asset health data via plug-and-play sensors.
- 3D digital twin enables users to navigate the virtual site from their desks.
- Provides up-to-date digital representation of the site's environment using live telemetry updates. Charts (timed based and observation-over-depth) are available.
- Works on all devices including desktops, tablets and mobile phones using devices' native mobile browser.

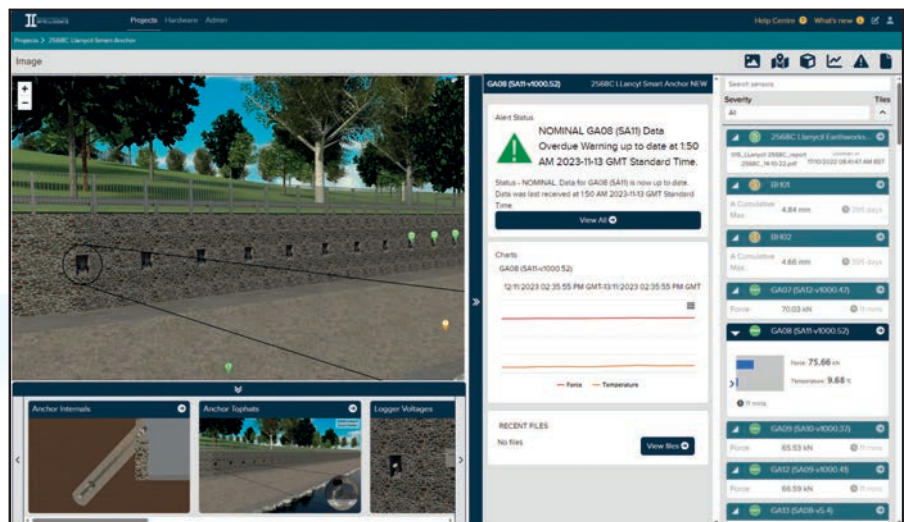

SMART ANCHOR INSTALLATION ON RETAINING WALL AT LLANYCIL, NORTH WALES

INNOVATIVE MONITORING AND SOLUTION FOR EMBANKMENT STABILISATION



Owner: Welsh Government
General contractor: Alun Griffiths
Products supplied: GEWI® Bar double corrosion protection anchor, DYWIDAG Smart anchor, embankment monitoring, Infrastructure Intelligence and testing.

DYWIDAG GEWI® pile system

DYWIDAG GEWI® and GEWI® Plus piles are micropiles compliant with EN 14199 standards. They serve as essential components of foundation systems, providing structural support in various construction projects. Unlike traditional piles, DYWIDAG micropiles operate as passive foundation elements, relying on their inherent strength and stability to bear vertical loads.

During installation, a GEWI® Threadbar is carefully inserted into a borehole with a maximum diameter of 300mm. A spacer is employed to centre the threadbar within the borehole, maintaining uniformity and stability throughout the pile's length.

In environments with highly aggressive ground conditions, such as those prone to corrosion or chemical exposure, DYWIDAG offers a specialised solution.

Due to their reliance on skin friction for load transfer, GEWI® and GEWI® Plus piles are versatile foundation elements capable of accommodating various types of loads, including compression, tension, and alternating loads. This flexibility makes them suitable for a wide range of applications, from building foundations and retaining walls to slope stabilisation and infrastructure reinforcement projects.

Fields of application

- Retaining structures.
- Uplift restraint.
- Stabilisation.
- Baseplates.
- Retaining structures.
- Dam construction.
- Bridges.
- Mining.

Key features

- **Passive foundation system:**
Typically installed as passive foundation elements, these piles do not require tensioning and rely on their inherent strength to support vertical loads.
- **Corrosion protection:**
In environments with highly aggressive ground conditions, such as corrosive soils or chemical exposure, DYWIDAG offers double corrosion tension piles with enhanced corrosion protection measures.
- **Versatile load transfer:**
These piles primarily rely on skin friction for load transfer, allowing them to accommodate compression, tension, and alternating loads with flexibility and reliability.
- **Wide range of applications:**
Suitable for various construction and engineering projects, including building foundations, retaining walls, bridge foundations, slope stabilisation, deep excavations, and environmental remediation.
- **Durable and long-lasting:** Manufactured from high-quality materials and engineered for durability, GEWI® and GEWI® Plus piles offer long-term stability and performance in challenging soil and environmental conditions.

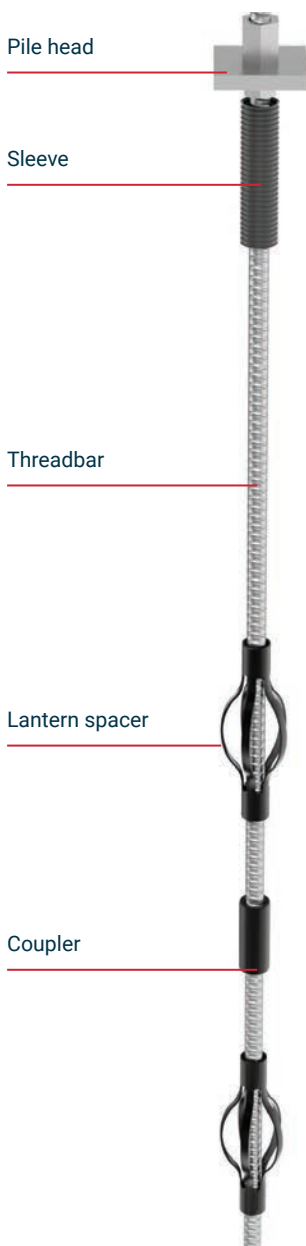

DYWIDAG GEWI® pile

Nominal diameter \emptyset	Yield strength / tensile strength $f_{0,2k}/f_{tk}$	Cross-sectional area A	Load at yield F_{yk}	Ultimate load F_{tk}	Weight	Weight double corrosion protection
[mm]	[N/mm ²]	[mm ²]	[kN]	[kN]	[kg/m]	[kg/m]
16	500/550	201	101	111	1.58	5.2
20	500/550	314	157	173	2.47	5.9
25	500/550	491	245	270	3.85	7.0
28	500/550	616	308	339	4.83	8.6
32	500/550	804	402	442	6.31	9.5
36	500/550	1,020	510	560	7.99	11.9
40	500/550	1,257	628	691	9.86	13.6
43	500/550	1,452	726	799	11.40	19.8
50	500/550	1,963	982	1,080	15.41	21.0
57.5	555/700	2,597	1,441	1,818	20.38	27.1
63.5	555/700	3,167	1,758	2,217	24.86	32.4
75	500/550	4,418	2,209	2,430	34.68	42.82

DYWIDAG GEWI® pile plus

Nominal diameter \emptyset	Yield strength / tensile strength $f_{0,2k}/f_{tk}$	Cross-sectional area A	Load at yield F_{yk}	Ultimate load F_{tk}	Weight	Weight double corrosion protection
[mm]	[N/mm ²]	[mm ²]	[kN]	[kN]	[kg/m]	[kg/m]
18	670/800	254	170	204	2.00	5.4
22	670/800	380	255	304	2.98	6.5
25	670/800	491	329	393	3.85	7.0
28	670/800	616	413	493	4.83	8.6
30	670/800	707	474	565	5.55	9.0
35	670/800	962	645	770	7.55	11.3
43	670/800	1,452	973	1,162	11.40	15.8
50	670/800	1,963	1,315	1,570	15.40	22.8
57.5	670/800	2,597	1,740	2,077	20.38	30.0
63.5	670/800	3,167	2,122	2,534	24.86	32.4
75	670/800	4,418	2,960	3,534	34.68	38.0

Double corrosion protection micropile



Double corrosion protection micropiles are a type of foundation system used in construction to provide support for structures in areas with challenging ground conditions or limited space.

This design incorporates additional corrosion protection measures to enhance the pile's durability and resistance to environmental degradation, ensuring long-term reliability even in challenging ground conditions.

Double corrosion protected tension piles feature two layers of protection against corrosion. This dual-layer system safeguards the steel pile, extending its lifespan in aggressive ground conditions where conventional piles may corrode prematurely.

Fields of application

- Foundations.
- Uplift restraint.
- Baseplates.
- Retaining structures.
- Underpinning.
- Bridges.
- Harbours and marine.
- Tunnelling.

Key features

- **Enhanced corrosion resistance:** Designed to withstand harsh environmental conditions, including exposure to moisture, chemicals, and saltwater, thanks to their advanced corrosion-resistant coatings.
- **Longevity and durability:** The combination of multiple corrosion protection layers ensures the long-term durability and extended service life of GEWI® and GEWI® Plus bars, making them ideal for use in aggressive environments such as marine structures, coastal areas, or chemical plants.
- **Customisation options:** Available in various diameters, lengths, and configurations to suit specific project requirements, offering flexibility and versatility in design and construction.

18 **Connecting communities with Silvertown Tunnel: Easing London's congestion**

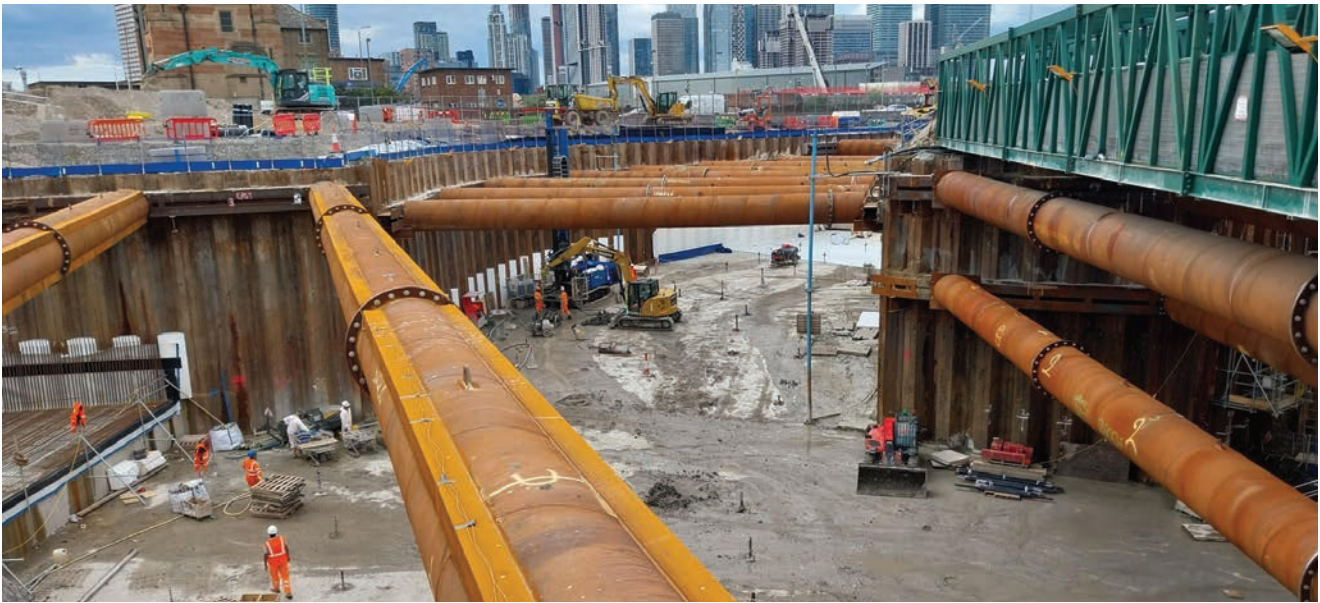

Owner: Riverlinx Consortium
General Contractor: Riverlinx CJV

Products supplied: Tension Piles, 50mm GEWI® double corrosion protection bar
This new 1.4km twin-bore tunnel, London's first in over 30 years, will enhance road network reliability and resilience through modern design, a user charge, and upgraded cross-river public transport.

Restoration of Toddbrook Reservoir to prevent future floods



Owner: Canal & River Trust
General contractor: Kier

Products Supplied: GEWI® Plus double corrosion tension piles
We collaborated with Kier to repair the Toddbrook Reservoir's spillway using our GEWI® Plus double corrosion tension piles. This initiative addresses the July 2019 damage and ensures enhanced safety and resilience, following the evacuation of 1,500 residents.

DYWIDAG Threadbar soil nails

DYWIDAG GEWI® bars are used as a ground reinforcement technique to stabilise steep slopes, excavations, or retaining structures.

It involves the installation of steel bars, referred to as soil nails, into the ground at specified angles and spacings.

These nails are typically grouted into place, providing increased shear strength and stability to the surrounding soil mass.

Soil nails are commonly utilised in construction projects to prevent slope failure, mitigate landslide risks, and support structures in areas with challenging geological conditions.

Fields of application

- Retaining structures.
- Slope stabilisation.
- Excavation support.
- Tunnels.
- Coastal protection.
- Mining and quarrying.

Key features

- **High strength:** Manufactured from high-strength steel, offering superior tensile strength and load-bearing capacity.
- **Threaded design:** Features a continuous external thread along their entire length, allowing for easy and secure connection with nuts, couplers, or other structural elements.
- **Versatility:** Available in various diameters and lengths, they can be easily customised to meet specific load capacities and construction specifications.
- **Ease of installation:** Can be easily cut, threaded, and installed using standard construction equipment and techniques, minimising installation time and labour costs.
- **Cost-effectiveness:** Compared to traditional ground reinforcement methods, soil nails can be more cost effective, particularly for projects with challenging access or limited space.

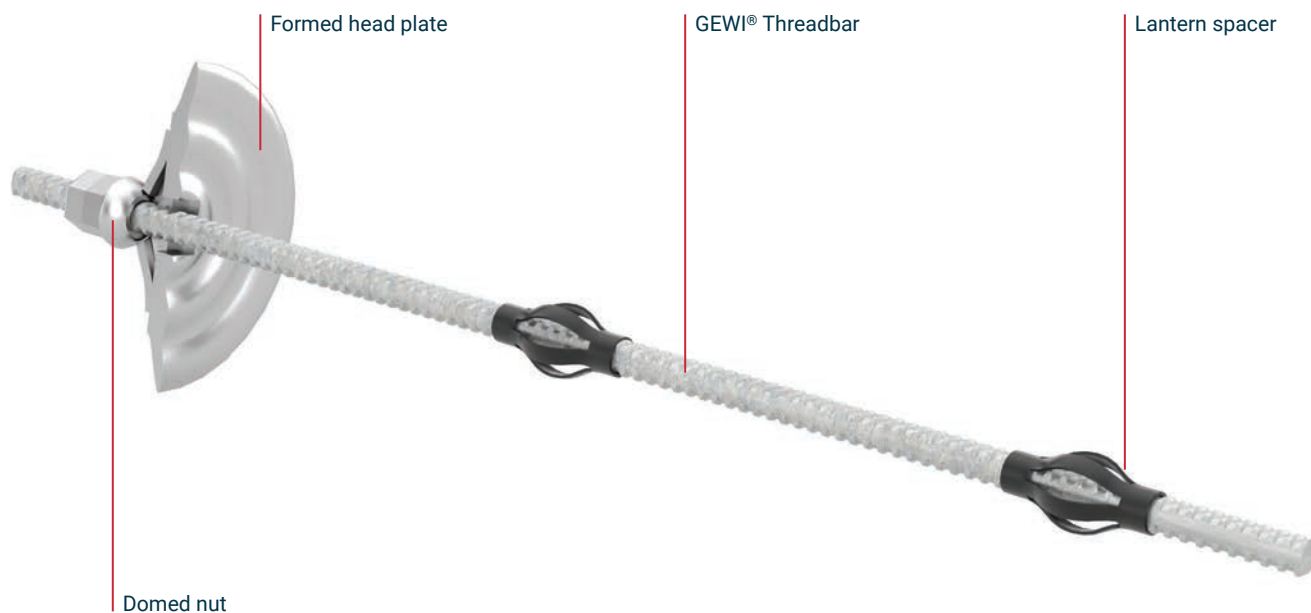

DYWIDAG Soil nails

GEWI® Threadbar soil nail / rock bolt, S670/800 threadbar

Nominal diameter \emptyset	Yield strength / tensile strength $f_{0,2k}/f_{tk}$	Cross-sectional area A	Load at yield F_{yk}	Ultimate load F_{tk}	Weight
[mm]	[N/mm ²]	[mm ²]	[kN]	[kN]	[kg/m]
16	500/550	201	101	111	1.58
20	500/550	314	157	173	2.47
25	500/550	491	245	270	3.85
28	500/550	616	308	339	4.83
32	500/550	804	402	442	6.31
36	500/550	1,018	510	560	7.99
40	500/550	1,257	628	691	9.86
43	500/550	1,452	726	799	11.40
50	500/550	1,963	982	1,080	15.41
57.5	555/700	2,597	1,441	1,818	20.38
63.5	555/700	3,167	1,758	2,217	24.86
75	500/550	4,418	2,209	2,430	34.68

GEWI® Plus threadbar soil nail / rock bolt, S670/800 threadbar

Nominal diameter \emptyset	Yield strength / tensile strength $f_{0,2k}/f_{tk}$	Cross-sectional area A	Load at yield F_{yk}	Ultimate load F_{tk}	Weight
[mm]	[N/mm ²]	[mm ²]	[kN]	[kN]	[kg/m]
18	670/800	254	170	204	2.00
22	670/800	380	255	304	2.98
25	670/800	491	329	393	3.85
28	670/800	616	413	493	4.83
30	670/800	707	474	565	5.55
35	670/800	962	645	770	7.55
43	670/800	1,452	973	1,162	11.40
57.5	670/800	2,597	1,740	2,077	20.38
63.5	670/800	3,167	2,122	2,534	24.86
75	670/800	4,418	2,960	3,534	34.68

Cliff stabilisation project to protect South West railway line

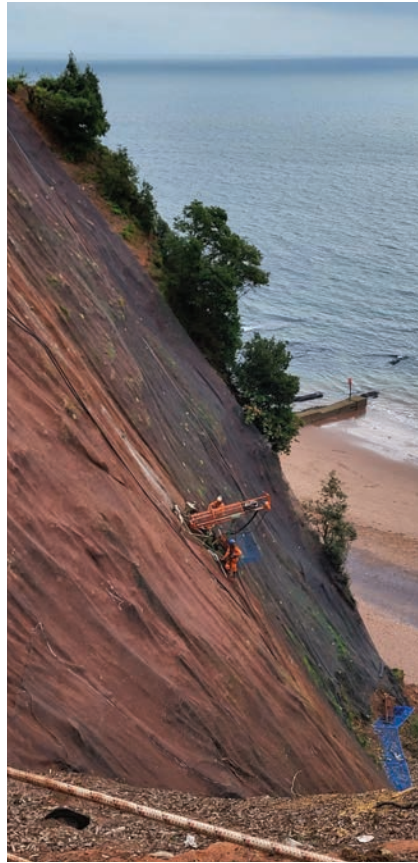

Owner: Network Rail

General contractor: BAM

Products supplied: GEWI® Plus and stainless steel combination bar

Cutting stabilisation to prevent rock fall



Owner: Network Rail

General contractor: BAM

Products supplied: GEWI® Threadbar



Hinkley Point C

Our bar anchors are being installed at Hinkley Point C, where EDF Energy is constructing two new nuclear reactors. This marks the beginning of a new generation of British nuclear power stations, set to provide zero-carbon electricity to approximately six million homes.

DYWIDAG Rock bolts

Fully grouted rock bolt

DYWIDAG rock bolts are utilised for stabilising rock masses in geotechnical engineering. Constructed from high-strength steel and corrosion-resistant materials, they offer durability and reliability in demanding environments. Featuring threaded ends for straightforward installation and compatibility with various anchoring systems, DYWIDAG rock bolts offer practical and efficient reinforcement for slopes, tunnels, and other structures.

Fields of application

- Retaining structures.
- Rock stabilisation.
- Excavation support.
- Coastal protection.
- Mining and tunnelling.
- Dams.

Key features

- **High strength:** Manufactured from high-quality steel with exceptional tensile strength, ensuring reliable reinforcement of rock masses and structures in demanding applications.
- **Threaded design:** Allows for easy and secure connection with nuts, plates, or other structural components.
- **Ease of installation:** Designed for easy installation with standard equipment and techniques, reducing time and labour costs and enhancing overall project efficiency.

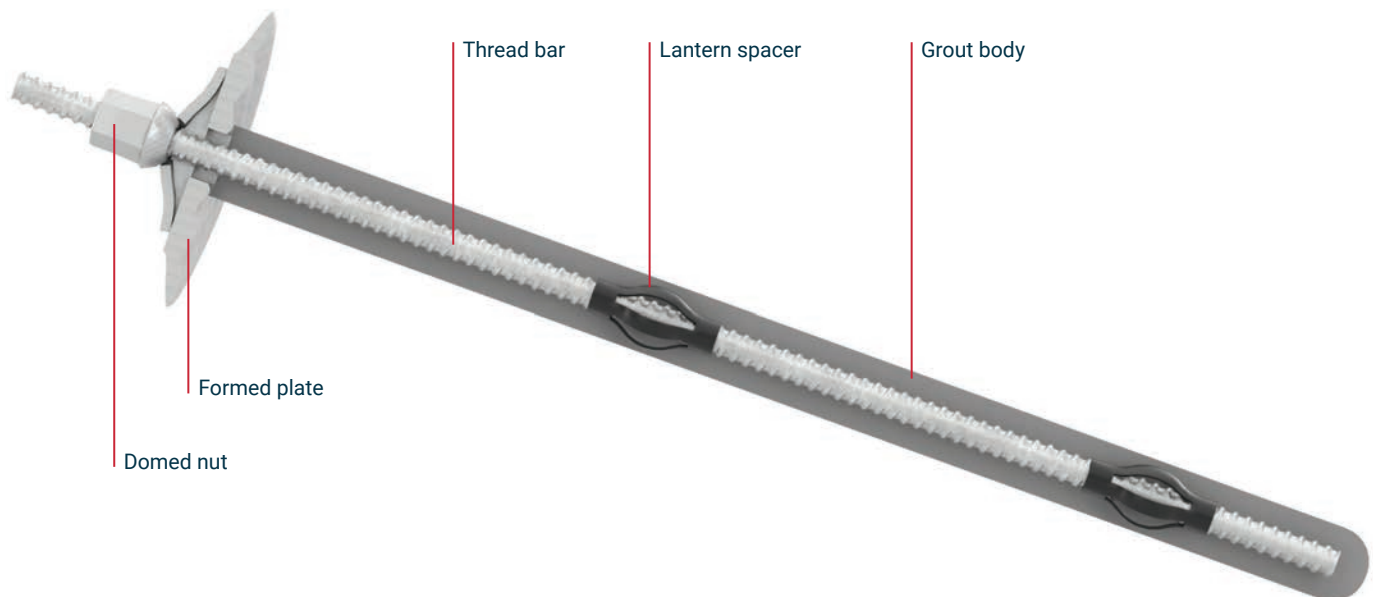

DYWIDAG Rock bolts

Rock bolts with expansion shell

DYWIDAG rock bolts with expansion shells offer reliable rock reinforcement for geotechnical projects. Made from high-strength materials, they provide immediate load-bearing capacity in the borehole upon installation. The expansion shell design ensures secure anchoring within the rock mass, enhancing structural stability.

Fields of application

- Rock stabilisation.
- Excavation support.
- Mining and tunnelling.
- Rockfall protection

Key features

- **Expansion mechanism:** Features a mechanism that expands the shell upon installation, anchoring it securely within the rock mass.
- **Ease of installation:** Designed for straightforward installation using standard drilling equipment and techniques. The expansion mechanism simplifies the installation process, saving time and labour costs on-site.
- **Compatibility:** Compatible with various anchoring systems, including plates, washers, and nuts, allowing for flexibility in design and installation.
- **Rapid load transfer:** Immediate load-bearing capacity within the borehole, swiftly transferring applied loads to the surrounding rock mass upon installation.

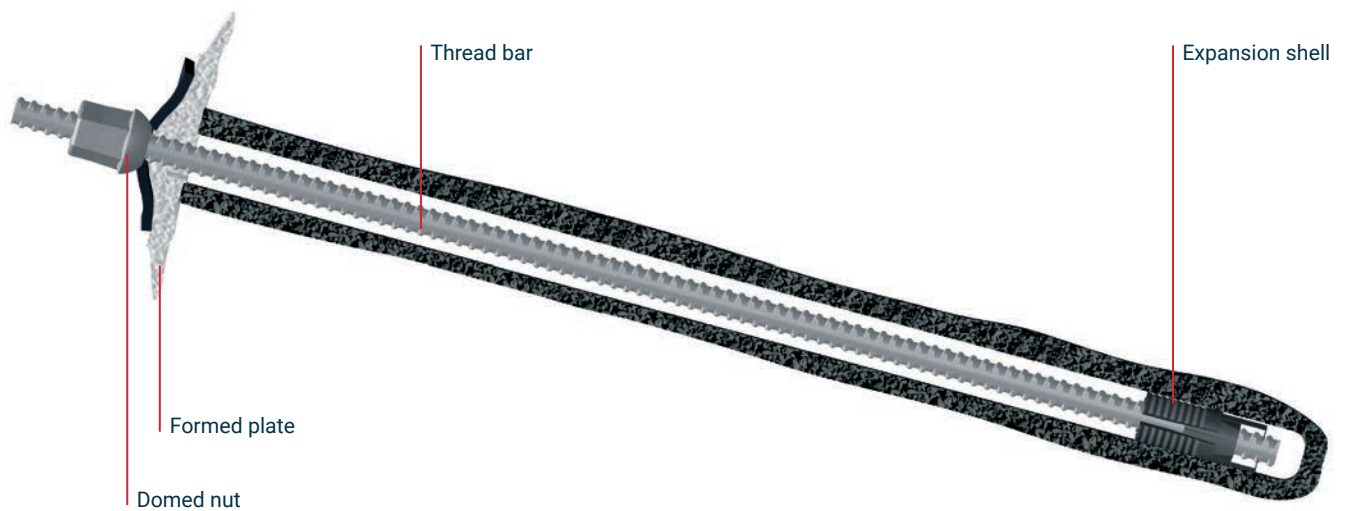



Owner: Waterford City

General contractor: Cumnor Construction Limited

Products supplied: Rock bolts – 40mm GEWI® and 20mm GEWI® galvanised bar

DYWIDAG DYWI® Drill hollow bar system

The DYWIDAG DYWI® Drill hollow bar is a fully threaded self-drilling system designed for loose or collapsing soils, eliminating the need for casing. Its hollow bore design allows simultaneous drilling and grouting, enhancing efficiency in ground support applications. Engineered with a left-hand thread for rotary percussive drilling, it ensures optimal performance and versatility.

Crafted from high-grade steel tubing, the DYWI® Drill hollow bar is cold rolled to form standard rope or "T" thread profiles, ensuring durability in various drilling scenarios. A comprehensive range of accessories, including drill bits, adaptor sleeves, couplers, nuts, and bearing plates, complements the hollow bar system, facilitating seamless integration into diverse project requirements.

Furthermore, the DYWI® Drill hollow bar system offers a variety of injection adaptors and drill tooling options, ensuring compatibility with a wide range of drilling equipment. With its robust construction and versatile capabilities, the DYWI® Drill hollow bar system is a trusted solution for ground support and reinforcement needs.

Fields of application

- Slope stabilisation.
- Excavation support.
- Tunnels.
- Foundations.
- Mining and quarrying.
- Retaining structures.
- Coastal protection.

Key features

- **Versatility:** Can be used in a wide range of applications, including soil nailing, Micropile construction, ground anchoring, rock bolting, and tunnelling.
- **Compatibility with accessories:** Compatible with a variety of accessories, such as drill bits, adaptor sleeves, couplers, nuts, and bearing plates, allowing for seamless integration into diverse project requirements.
- **Speed and ease of installation:** Designed for rapid and easy installation using standard drilling equipment, reducing labour costs and project timelines.
- **Dual functionality:** The tendon doubles as a drill rod and grouting conduit, simplifying installation and boosting efficiency in ground support applications.
- **Cost efficiencies:** Allows for lighter and more compact machinery resulting in reduced operational expenses compared to when using casing.

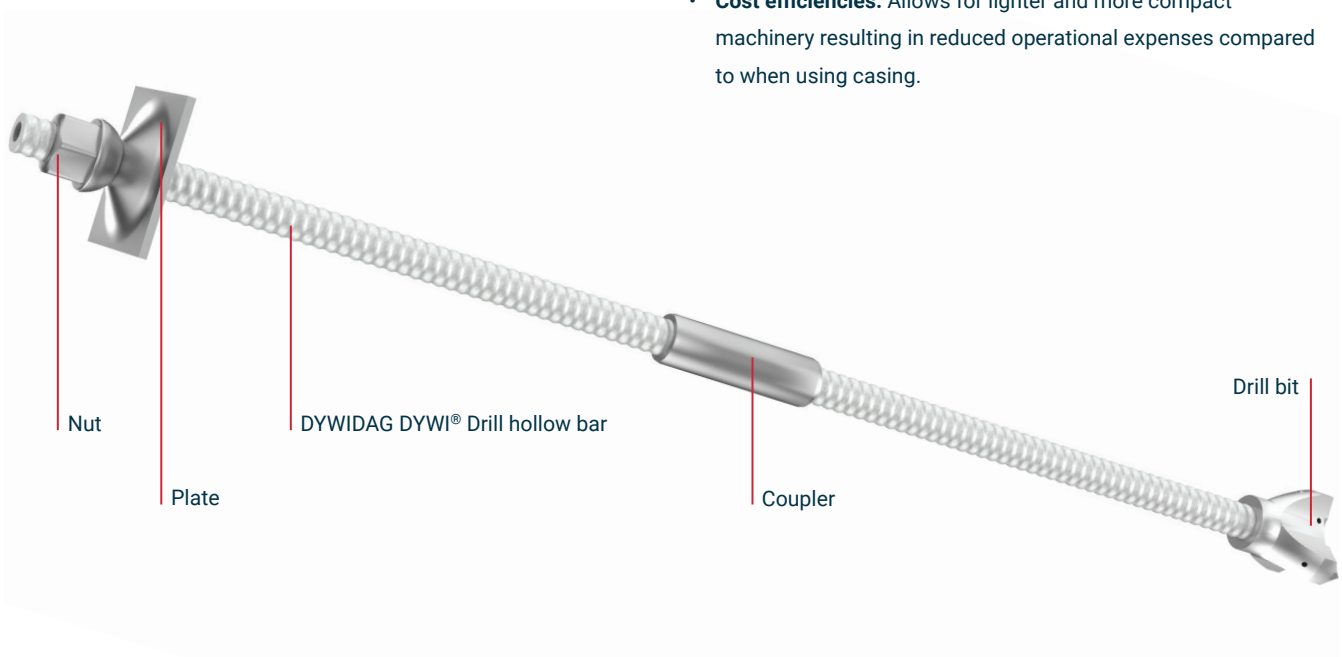

DYWIDAG DYWI® Drill hollow bar system

Bar type	Nominal thread diameter	Effective external diameter	Internal diameter	Cross section area	Ultimate strength	Yield strength	Steel grade yld / ult	Weight
	[mm]	[mm]	[mm]	[mm ²]	[kN]	[kN]	[N/mm ²]	[kg/m]
Typical soil nail application								
R25-200	25	23.8	14	290	200	150	520/690	2.30
R32-210	32	29.5	21.5	340	210	170	530/660	2.80
R32-250	32	29.5	19.7	370	250	190	510/670	3.00
R32-280	32	29.5	18	410	280	220	520/670	3.40
R32-320	32	29.5	16.5	470	320	280	590/680	3.90
R32-360	32	29.5	15	510	360	300	590/710	4.10
R38-420	38	36.4	21	660	420	350	510/610	5.30
R38-500	38	36.4	19	750	500	400	530/660	6.00
R38-550	38	36.40	18.2	780	550	430	550/710	6.2
Typical micropile application								
R51-550	51	48.4	35	810	550	450	510/630	7.10
R51-660	51	48.4	33	970	660	530	540/670	7.80
R51-800	51	48.4	30.5	1,150	800	630	570/720	9.00
R51-925	51	48.4	27.5	1,275	925	730	595/775	9.60
T76-1300	76	73.5	57.5	1,590	1,300	1,000	630/820	12.5
T76-1650	76	73.5	54.1	1,975	1,650	1,200	610/835	15.5
T76-1900	76	73.5	49.4	2,360	1,900	1,500	640/810	18.5
T103-2300	103	94	78	3,200	2,300	1,800	560/710	25
T103-3700	103	94	51	5,200	3,700	2,700	560/710	40

28 Corrosion protection

The durability of hollow bar systems can be greatly threatened by corrosion, especially in moist or aggressive soil conditions. Consequently, corrosion protection measures are crucial to ensure the longevity and reliability of soil nailing and micro piling projects. Corrosion can cause structural deterioration, reduced load-bearing capacity, and potentially catastrophic failures. Therefore, implementing robust corrosion protection strategies is essential to mitigate these risks and prolong the service life of hollow bar systems.

Corrosion protection can be achieved through the following methods:

Sacrificial corrosion allowance

Sacrificial corrosion allowance, when utilised in corrosion protection for hollow bars, involves intentionally designing the bars with additional material thickness to accommodate gradual corrosion over time without compromising structural integrity. The amount of corrosion allowance is determined based on studies aligned with standards such as TRL 380, EN14199, and CIRIA C637.

These standards provide guidelines for assessing factors such as expected corrosion rates, environmental conditions, and the intended service life of the bars. By incorporating sacrificial corrosion allowance into the design of hollow bars, engineers ensure that the bars can withstand corrosion while maintaining their structural strength and performance over time.

Galvanising

Galvanising for corrosion protection in hollow bars involves coating the bar's surface with a layer of zinc, typically done through hot-dip galvanising. This process, as outlined in EN1461 standards, creates a metallurgical bond between the zinc and the steel, forming a protective barrier against corrosion.

The zinc coating sacrificially corrodes to shield the steel from rust, providing an additional 5-15 years of lifespan to the hollow bars. It's a widely used and effective method for extending the lifespan of hollow bars in various applications, ensuring structural integrity in harsh environments.

Duplex coating

In corrosion protection for hollow bars, duplex coatings refer to the application of two protective layers, a hot-dip galvanisation layer followed by an additional epoxy powder coating. The hot-dip galvanisation provides the first line of defence against corrosion, forming a metallic barrier over the surface of the hollow bar. On top of this, the epoxy powder coating adds an extra layer of protection, further shielding the bar from corrosive elements.

The combination of these two coatings creates a duplex system that offers enhanced corrosion resistance compared to using either coating alone. Even if the epoxy coating is damaged during installation, the galvanised layer provides continued protection, ensuring the longevity and durability of the hollow bar in corrosive environments.

Increasing durability

Sacrificial corrosion protection

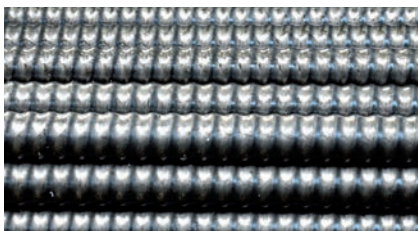

Galvanising



Duplex coating

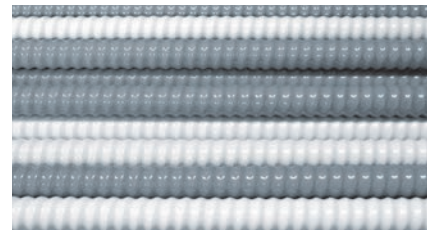

Sacrificial corrosion

The quantity of steel loss is based on research in accordance with TRL380 EN14199 and CIRIA C637.

Bar size	Soil aggressivity	Sacrificial thickness	Sectional area	Ultimate strength	0.2% Yield strength	Sacrificial thickness	Sectional area	Ultimate strength	0.2% Yield strength
		[mm]	[mm ²]	[kN]	[kN]	[mm]	[mm ²]	[kN]	[kN]
		60 Year design life				120 Year design life			
R32-210	low	0.8	301	187	143	1.4	274	171	130
	middle	1.5	269	168	128	2.5	226	141	107
	high	2.8	214	133	101	4.9	129	80	61
R32-250	low	0.8	333	225	171	1.4	306	207	157
	middle	1.5	302	204	155	2.5	258	175	133
	high	2.8	246	166	126	4.9	161	109	83
R32-280	low	0.8	378	255	201	1.4	351	237	186
	middle	1.5	347	234	184	2.5	304	205	161
	high	2.8	291	197	154	4.9	206	139	110
R32-320	low	0.8	433	295	231	1.4	406	277	216
	middle	1.5	402	274	214	2.5	359	244	191
	high	2.8	346	236	184	4.9	261	178	139
R32-360	low	0.8	470	334	260	1.4	443	315	245
	middle	1.5	439	312	243	2.5	396	218	219
	high	2.8	383	272	212	4.9	299	212	165
R38-420	low	0.8	621	392	327	1.4	588	371	309
	middle	1.5	583	367	306	2.5	529	333	278
	high	2.8	513	324	270	4.9	406	256	214
R38-500	low	0.8	701	470	376	1.4	668	448	358
	middle	1.5	662	444	355	2.5	608	408	326
	high	2.8	593	397	318	4.9	486	326	261
R38-550	low	0.8	757	519	425	1.4	724	496	406
	middle	1.5	719	493	403	2.5	665	456	373
	high	2.8	649	445	364	4.9	542	372	304
R51-550	low	0.8	830	513	420	1.4	785	485	397
	middle	1.5	778	481	393	2.5	705	436	357
	high	2.8	684	423	346	4.9	538	332	272
R51-660	low	0.8	909	619	507	1.4	865	589	482
	middle	1.5	858	584	478	2.5	785	534	437
	high	2.8	764	520	425	4.9	617	420	344
R51-800	low	0.8	1,104	759	607	1.4	1,060	728	583
	middle	1.5	1,052	723	579	2.5	980	673	539
	high	2.8	958	659	527	4.9	812	558	446
R51-925	low	0.8	1,171	904	694	1.4	1,126	869	668
	middle	1.5	1,119	864	664	2.5	1,046	808	621
	high	2.8	1,025	791	608	4.9	879	678	521
T76-1300	low	0.8	1,530	1,228	944	1.4	1,463	1,174	903
	middle	1.5	1,452	1,165	896	2.5	1,342	1,077	828
	high	2.8	1,309	1,050	808	4.9	1,084	870	669
T76-1650	low	0.8	1,891	1,575	1,145	1.4	1,824	1,519	1,105
	middle	1.5	1,813	1,510	1,098	2.5	1,703	1,418	1,031
	high	2.8	1,670	1,390	1,011	4.9	1,444	1,202	874
T76-1900	low	0.8	2,280	1,828	1,443	1.4	2,213	1,774	1,400
	middle	1.5	2,202	1,765	1,393	2.5	2,092	1,676	1,323
	high	2.8	2,059	1,650	1,303	4.9	1,833	1,469	1,160
T103-2300	low	0.8	2,935	2,206	1,777	1.4	1,824	1,519	1,105
	middle	1.5	2,826	2,124	1,711	2.5	1,703	1,418	1,031
	high	2.8	2,627	2,187	1,590	4.9	1,444	1,202	874
T103-3700	low	0.8	5,670	4,545	3,588	1.4	2,213	1,774	1,400
	middle	1.5	5,562	4,458	3,519	2.5	2,092	1,676	1,323
	high	2.8	5,362	4,298	3,393	4.9	1,833	1,468	1,160

Micropiles

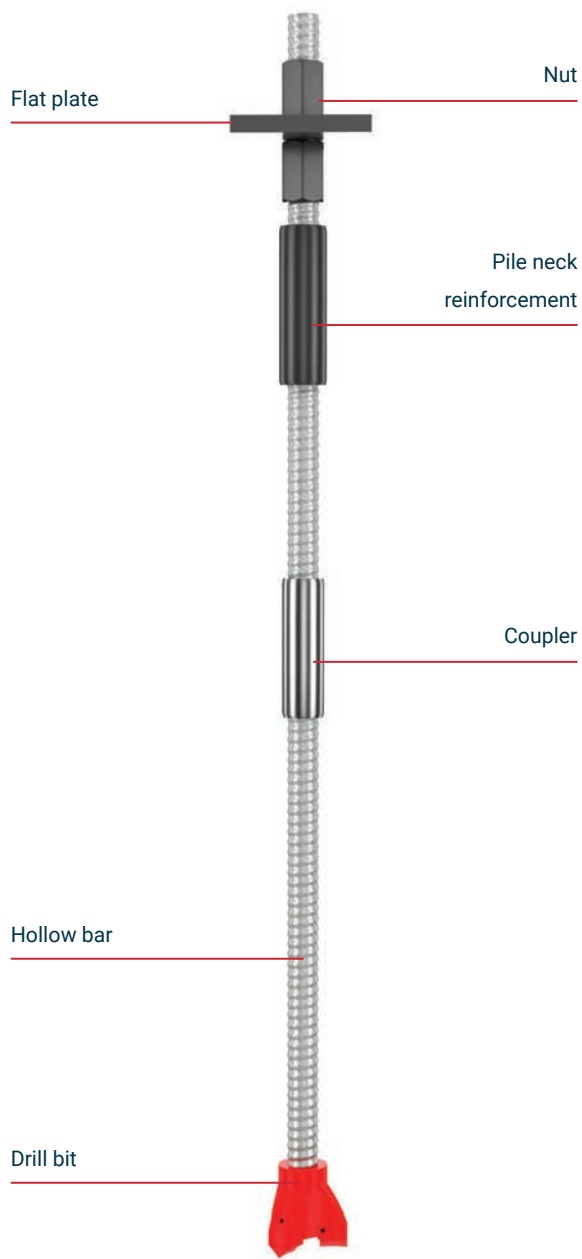

The DYWIDAG DYWI® Drill hollow bar micropiles are ideal for installation in restricted access areas or close to buildings. With a fully threaded design, these micropiles can be extended and grouted even if the founding level is higher than anticipated, meeting the standards set by EN 14199.

By employing rotary percussive drilling, installation disruptions are minimised, providing an alternative to driven piling systems. This approach facilitates foundation improvement in existing structures or buildings with minimal disturbance.

Fields of application









- Tunnels.
- Foundations.
- Retaining structures.
- Uplift restraint.

Key features

- **Versatility:** Suitable for various ground conditions, including soil, rock, and congested or contaminated sites.
- **Limited access capability:** Can be installed in tight spaces like urban areas, slopes, or inside structures due to small equipment footprint and flexible angles.
- **Minimal environmental impact:** Causes minimal soil disturbance, ideal for sensitive or urban areas.
- **Fast installation:** Quick and efficient, reducing construction time and costs compared to traditional methods.

DYWIDAG DYWI® Drill hollow bar system

Available drill types and diameters

Drill bit type	CRC	EC	ECC	EY	EYY	EX	EXX	ES	ESS
Ground conditions	Loose soils - gravels, fills, clay	Loose soils - gravels, fills, clay	Intermediate gravels	Intermediate gravels	Dense gravel, soft rock	Dense gravel, soft rock	Dense gravel, soft rock	Intermediate gravels	Rock
Bar type	Two-stage rs-flush (retro & side flush), hardened	Arc-shaped, hardened	Arc-shaped, carbide inserts	Arc-shaped button, hardened	Arc-shaped button, carbide inserts	Cross, hardened	Cross, carbide inserts	Button, hardened	Button, carbide inserts
									
R25						42	42	42	42
R32	75,100	51,76	51,76	76,90	76,90	51,76	51,76	51,76	51,76
R38	110,130	76		76,90,115	76,90,115	76,90,115	76,90,100,115	76,90,100,115	76,90,100,115
R51	150,175			76,90,115,130	76,90,115	100,115	100,115	76,100,115	76,100,115
T76				130,150	130,150	130,150	130	130,150	130,150
T103	220						175	175	175

Use R25 / R32 adaptor sleeve to fit R32 drill bit to R25 hollow bar.

Use R32 / R38 adaptor sleeve to fit R38 drill bit to R32 hollow bar.

Other diameters available. Drill bit is a welded fabrication, therefore, cutting Ø can be enlarged to suit borehole requirements.

Drill bit adaptor sleeves



Couplers and nuts



Complex reconstruction of a retaining wall with a hybrid soil nail geogrid system



Owner: Herefordshire County Council

General contractor: Alun Griffiths

Products supplied: DYWIDAG DYWI® Drill hollow bar R32, specialist connection detail and facing mesh

A12 widening using hollow bar soil nails



Owner: National Highways

General contractor: CAN Ltd

Products supplied: Hollow bar R32

DYWIDAG Stainless steel threadbar

DYWIDAG stainless steel threadbar is manufactured from both 1.4301 (304) and 1.4401 (316) grade steel. It has been developed for permanent applications requiring higher levels of corrosion resistance compared to standard structural steel products. Stainless steel Threadbar is a coarse pitch, fully threaded bar system, suitable for both geotechnical and structural applications.

Stainless steel bars are extensively utilised in repairing existing masonry structures or bridges on railways and highways, as well as in rock bolting and stabilisation in highly corrosive environments, such as coastal protection works.

Featuring a coarse-pitched thread running the entire length, stainless steel threadbar allows cutting or coupling at any point. Additionally, it incorporates a full load nut termination at the end for load transfer to the structure's face.

Fields of application

- Slope stabilisation.
- Tunnels.
- Foundations.
- Mining and quarrying.
- Retaining structures.
- Coastal protection.
- Bridges and masonry structures

Key features

- **Corrosion resistance:** highly resistant to corrosion, suitable for use in environments with high levels of moisture, salt, or chemical exposure.
- **Low maintenance:** Stainless steel requires minimal maintenance, reducing the need for costly repairs or replacements over time.
- **Durability:** Stainless steel is known for its durability and long lifespan, ensuring the threadbar maintains its structural integrity over time.
- **Strength:** Stainless steel threadbars offer high tensile strength, providing reliable support and load-bearing capacity in various applications.



Stainless steel threadbar

Diameter	Cross section	Steel grade	Ultimate strength	Weight
[mm]	[mm ²]	[N/mm ²]	[kN]	[kg/m]
16	167	650/800	133	1.31
20	261	650/800	208	2.05
24	378	650/800	302	2.98
30	596	650/800	476	4.70
35	873	650/800	698	6.84

34 DYWI® Drill stainless steel hollow bar

The DYWIDAG DYWI® Drill stainless steel hollow bar, made from 1.4401 (316) grade steel, is engineered for enduring use in permanent applications demanding heightened corrosion resistance, particularly in marine and coastal environments.

Stainless steel hollow bars are extensively used in repairing existing masonry structures or bridges on railways and highways, as well as in slope stabilisation within highly corrosive coastal environments.

The stainless steel hollow bar can be installed directly into loose soils without requiring casing. Additionally, the rope and T-thread are suitable for use within the DYWIDAG DYWI® Drill bit range.



Fields of application

- Coastal protection.
- Slope stabilisation.
- Tunnels.
- Foundations.
- Mining and quarrying.
- Retaining structures.
- Bridges and masonry structures.

Key features

- **Corrosion resistance:** Highly resistant to corrosion, suitable for use in environments with high levels of moisture, salt, or chemical exposure.
- **Low maintenance:** Reducing the need for costly repairs or replacements over time.
- **Durability:** Known for its durability and long lifespan, ensuring the bar maintains its structural integrity over time.
- **Strength:** Offers high tensile strength, providing reliable support and load-bearing capacity in various applications.

DYWI® Drill stainless steel hollow bar

Bar type	Nominal diameter	Effective diameter	Internal diameter	Cross Section	Steel Grade	E Value	Ultimate strength	Yield strength	Section modulus	Moment of inertia	Weight
	[mm]	[mm]	[mm]	[mm ²]	[N/mm ²]	[N/mm ²]	[kN]	[kN]	[CM ³]	[CM ⁴]	[kg/m]
R32-280	32	29.1	17.5	430	650/510	190,000	280	220	2.1	3.1	3.4
R32-360	32	29.1	14.5	550	560/720	190,000	360	280	2.3	3.3	4.2
R38-500	38	35.7	17.5	760	650/520	190,000	500	400	4.2	7.5	6.0

DYWIDAG DYWI® Drill stainless steel hollow bar stabilises failing slopes at the Severn Estuary



Owner: Network Rail

General contractor: QTS

Products supplied: DYWIDAG DYWI® Drill stainless steel R32 hollow bar

DYWIDAG High Tensile Hex mesh

DYWIDAG High Tensile Hex (HTH) mesh system offers a durable, easy-to-install solution for slope stabilisation, providing strong protection against rockfall and soil instability with superior corrosion resistance and design flexibility.

This fully tested, patented, and approved system has high tensile and punching strengths, ensuring robust protection against rockfall and soil instability.

The lightweight design allows for easy installation and is easy to cut. The mesh features Class A ZnAl coatings, offering superior corrosion resistance and longevity.

For projects requiring the utmost in corrosion protection, we also offer stainless steel options, ensuring the system maintains its integrity even in the harshest conditions.

The comprehensive range of mesh systems has been carefully designed to complement DYWIDAG's range of existing slope stabilisation products.

Manufactured in Europe with technical approvals, this competitively priced system offers a dependable and cost-effective choice for your geotechnical needs.



DYWIDAG HTH MESH APPLICATION: RAILWAY EMBANKMENT



DYWIDAG GEWI (R)
THREADBAR AND HTH MESH

Compatible Products

- DYWI® DRILL hollow bar.
- GEWI® Threadbar.
- Stainless steel threadbar.
- DYWI® DRILL stainless steel hollow bar.
- Combination bar.
- All accessories.

Uses

- Rockfall protection.
- Landslide mitigation.
- Slope stabilisation.

Applications

- Embankments & cuttings.
- Marine and Coastal.
- Quarry faces.
- Tunnels.
- Mines.

Key Features

- **High-tensile strength**
Exceptional resistance to deformation and failure under heavy loads, ensuring lasting stability.
- **Lightweight**
Easy installation and cutting of panels, saving time and effort on-site.
- **Simplified plate design**
Cost-effective and designed for seamless compatibility with all DYWIDAG bars.
- **Superior durability**
Class A ZnAl coatings and optional stainless steel, ensure long-term performance, even in extreme conditions.
- **Cost-effective**
Competitive pricing combined with straightforward installation and extended durability.

DYWIDAG Mesh product range

High Tensile Hexagonal (HTH)

Standard Class A coating 95%Zn / 5%Al to EN 102442-2

DYWI® HTH	Units	HTH 85 S	HTH 150 S	HTH 200 S
Anti-corrosion coating	g/m ²	215	245	255
Mesh size	mm	65 x 120	65 x 120	65 x 120
Wire diameter	mm	2	2.7	3
Tensile strength of wire	N/mm ²	1770	1770	1770
Tensile strength of mesh	kN/m	>85	>150	>200
Punching resistance	kN/m ²	>100	>180	>240
Mesh elongation	%	<6	<6	<6

Standard Class A coating is used for projects in inland and rural areas:

- Long lasting protection up to 120 years.
- Ideal for low corrosion environments.

Advanced Class A coating 90%Zn / 10%Al to EN 102442-2

DYWI® HTH	Units	HTH 85 A	HTH 150 A	HTH 200 A
Anti-corrosion coating	g/m ²	215	245	255
Mesh size	mm	65 x 120	65 x 120	65 x 120
Wire diameter	mm	2	2.7	3
Tensile strength of wire	N/mm ²	1770	1770	1770
Tensile strength of mesh	kN/m	>85	>150	>200
Punching resistance	kN/m ²	>100	>180	>240
Mesh elongation	%	<6	<6	<6

Advanced Class A coating gives greater corrosion resistance in areas of coastal and urban areas with low to medium pollution:

- Enhanced corrosion resistance.
- Lifespan of 60 to 120 years.
- Versatile application across various environments.

Duplex stainless steel wire 1.4462 to AISI318LN

DYWI® HTH DS	Units	HTH 85 DS	HTH 150 DS	HTH 200 DS
Stainless steel wire 1.4462		Duplex	Duplex	Duplex
Mesh size	mm	65 x 120	65 x 120	65 x 120
Wire diameter	mm	2	2.7	3
Tensile strength of wire	N/mm ²	1650	1650	1650
Tensile strength of mesh	kN/m	>85	>150	>200
Punching resistance	kN/m ²	>90	>180	>200
Mesh elongation	%	<6	<6	<6

DYWI DS Mesh is primarily used in coastal areas:

- High resistance to marine environment.
- Exceptional performance in high pollution areas.
- Unrivalled longevity – lasting over 120 years.

DYWIDAG's mesh system includes all necessary components for a smooth and efficient installation

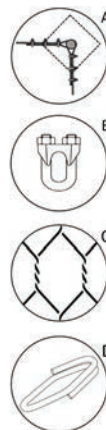
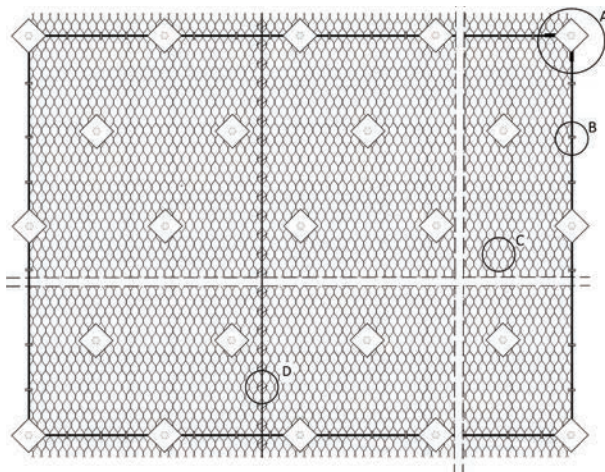

12mm or 16mm diameter border ropes/DYWIDAG plates & bolts/nails.

Turnbuckle grip connectors.

Mesh.

Panel clips.

HTH Mesh with erosion control mat

Designed to combat soil erosion and promote vegetation establishment for slope stabilisation projects.

This innovative product combines the strength of DYWIDAG HTH Mesh with the protective qualities of DYWIDAG's erosion control mat, providing immediate protection against surface erosion whilst creating an ideal structure for seed germination and vegetation growth.

Engineered with durability and offering a robust, sustainable approach to soil stabilisation and landscape restoration.

HTH Mesh with integrated 3-D polymer erosion control mat

DYWI® HTH EC	Units	Standard coating class A 95%Zn / 5%Al to EN 102442-2		Advanced coating class A 90%Zn / 10%Al to EN 102442-2	
		HTH 85 S EC	HTH 150 S EC	HTH 85 A EC	HTH 150 A EC
Anti-corrosion coating	g/m ²	215	245	215	245
Mesh size	mm	65 x 120	65 x 120	65 x 120	65 x 120
Wire diameter	mm	2	2.7	2	2.7
Tensile strength of wire	N/mm ²	1770	1770	1770	1770
Tensile strength of mesh	kN/m	>85	>150	>85	>150
Punching resistance	kN/m ²	>100	>180	>100	>180
Mesh elongation	%	<6	<6	<6	<6



Uses

- Slope stabilisation.

Applications

- Embankments & cuttings.
- Riverbanks.
- Marine and Coastal.

Key Features

• Strength and erosion control

Provides immediate, robust protection against surface erosion, ensuring the stability of vulnerable areas from the moment it's installed.

• Vegetation enhancement

Actively promotes seed germination and accelerates plant growth, speeding up the natural restoration process and improving long-term sustainability.

• Exceptional versatility

Suitable for a wide range of applications, including slopes, embankments, riverbanks, and more, adapting to various project needs with ease.

• Superior durability

Class A ZnAl coatings and optional stainless steel, ensure long-term performance, even in extreme conditions.

• Cost-effective

Minimises overall project expenses by reducing both initial installation costs and long-term maintenance requirements.

LCH Mesh for passive applications

For applications where lower tensile strengths are required, DYWI® LCH mesh provides a cost-effective solution.

Designed for projects with passive load environments, such as applications where the mesh is draped over steep slopes to control rockfall and guide debris safely to the base, preventing potential safety hazards below.

Its hexagonal structure and double-twist design provide durability and resistance, ensuring long-lasting performance.

Made from galvanised steel, the mesh is corrosion-resistant and easy to install, making it a cost-effective solution for various projects.

DYWI® LCH 55 S Standard Coating Class A 95%Zn /5%Al to EN 102442-2

DYWI® LCH Mesh	Units	LCH 55 S
Anti-corrosion coating	g/m ²	245
Mesh size	mm	65 x 120
Wire diameter	mm	2.7
Tensile strength of wire	N/mm ²	380
Tensile strength of mesh	kN/m	55kN/ m
Punching resistance	kN/m ²	70 kN
Mesh elongation	%	22



Uses

- Slope stabilisation.
- Rockfall protection.

Applications

- Embankments.
- Motorway and railway cutting stabilisation.
- Quarry face support.

Key Features

- **Rockfall protection**
Effectively prevents debris from reaching vulnerable areas, safeguarding assets and people from potential damage or injury.
- **Flexibility**
The mesh easily adapts to irregular surfaces and varied terrain, ensuring optimal coverage and protection.
- **Minimal visual impact**
Designed to blend seamlessly into natural landscapes, maintaining the aesthetic integrity of the surroundings, while providing essential safety.
- **Cost-efficient**
An economical solution for managing hazardous slopes, delivering reliable protection without compromising your budget.

DYWIDAG Tie bars - GEWI® and GEWI® Plus

In the marine sector, DYWIDAG GEWI® Tie bars are widely utilised in construction projects involving structures such as harbours, docks, dams, and other waterfront infrastructure. These tie bars are durable steel rods engineered to withstand tensile forces, making them well-suited for applications where structures must endure heavy loads or forces characteristic of marine environments.

GEWI® Tie bars serve multiple roles in marine construction projects. They are commonly used to securely anchor sheet pile walls, ensuring stability against external forces and they play a vital role in securing structures by tying back walls in Deadman structures.

Furthermore, these tie bars are instrumental in ensuring the positional stability of joint connections within marine structures, thereby preventing displacement or failure. This is essential for maintaining the structural integrity of the entire system, especially in areas where the forces exerted by waves, tides, and currents are significant.

An additional advantage of GEWI® Tie bars lies in their versatility. They can be cut at any point along their length, allowing for flexibility in installation and adaptation to specific on-site requirements. This feature enhances the ease of installation and customisation, making GEWI® tie bars invaluable in marine construction projects.

Overall, GEWI® Tie bars play a vital role in marine construction, contributing to the durability, stability, and integrity of various waterfront structures. Their ability to withstand forces, anchor structures securely, and adapt to specific project needs makes them indispensable components in the challenging marine environment.

Fields of application

- Coastal protection.
- Harbour and quay walls.
- Dam and ramp construction.
- Foundations.
- Bridges and masonry structures

Key features

- **High tensile strength:** Engineered to withstand high tensile forces, providing reliable anchoring and structural reinforcement in marine structures subjected to dynamic loads and forces.
- **Versatility:** Available in various lengths and diameters, allowing for flexibility in design and installation to meet specific project requirements. They can also be easily cut and adjusted on-site for precise fitting.
- **Easy installation:** Features threaded ends for easy connection to anchor points, streamlining construction even in challenging marine environments.
- **Compatibility:** Works with various anchoring and connection systems, ensuring seamless integration into different marine structures and existing infrastructure.

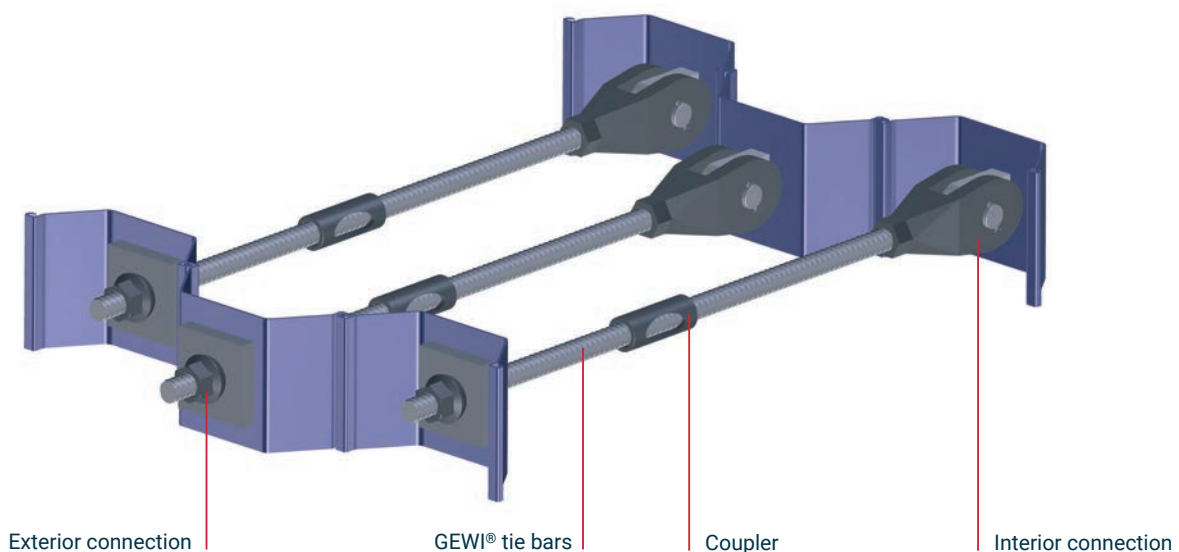

DYWIDAG Tie bars - GEWI® and GEWI® Plus

DYWIDAG GEWI®

Nominal diameter \emptyset	Yield strength / tensile strength $f_{0.2k}/f_{tk}$	Cross- sectional area A	Load at yield F_{yk}	Ultimate load F_{tk}	Weight
[mm]	[N/mm ²]	[mm ²]	[kN]	[kN]	[kg/m]
16	500/550	201	101	111	1.58
20	500/550	314	157	173	2.47
25	500/550	491	245	270	3.85
28	500/550	616	308	339	4.83
32	500/550	804	402	442	6.31
36	500/550	1,018	510	560	7.99
40	500/550	1,257	628	691	9.86
43	500/550	1,452	726	799	11.40
50	500/550	1,963	982	1,080	15.41
57.5	555/700	2,597	1,441	1,818	20.38
63.5	555/700	3,167	1,758	2,217	24.86
75	500/550	4,418	2,209	2,430	34.68

DYWIDAG GEWI® Plus

Nominal diameter \emptyset	Yield strength / tensile strength $f_{0.2k}/f_{tk}$	Cross- sectional area A	Load at yield F_{yk}	Ultimate load F_{tk}	Weight
[mm]	[N/mm ²]	[mm ²]	[kN]	[kN]	[kg/m]
18	670/800	254	170	204	2.00
22	670/800	380	255	304	2.98
25	670/800	491	329	393	3.85
28	670/800	616	413	493	4.83
30	670/800	707	474	565	5.55
35	670/800	962	645	770	7.55
43	670/800	1,452	973	1,162	11.40
50	670/800	1,963	1,315	1,570	15.40
57.5	670/800	2,597	1,740	2,077	20.38
63.5	670/800	3,167	2,122	2,534	24.86
75	670/800	4,418	2,960	3,534	34.68

Corrosion protection systems

We offer a range of corrosion protection systems for marine tie bars, including hot-dip galvanising, Denzo wrapping, sacrificial steel loss, and double corrosion protection, which complies with EN1537 standards, ensuring durability and longevity in challenging marine environments.

DYWIDAG Tie bars - GEWI® and GEWI® Plus

Tie bar connections

Tie bar connections are fundamental elements in various construction projects, offering stability and structural integrity. Different types, such as threaded couplers, articulated connections, and tensionable connections, serve specific purposes.

Threaded couplers facilitate secure connections while allowing for easy adjustments. Articulated connections provide flexibility to accommodate movements and vibrations, particularly beneficial in dynamic conditions.

Tensionable connections enable precise tensioning to meet specific load requirements, enhancing structural resilience.

These connection types are chosen based on project needs and environmental factors, ensuring optimal performance and longevity across diverse construction applications.

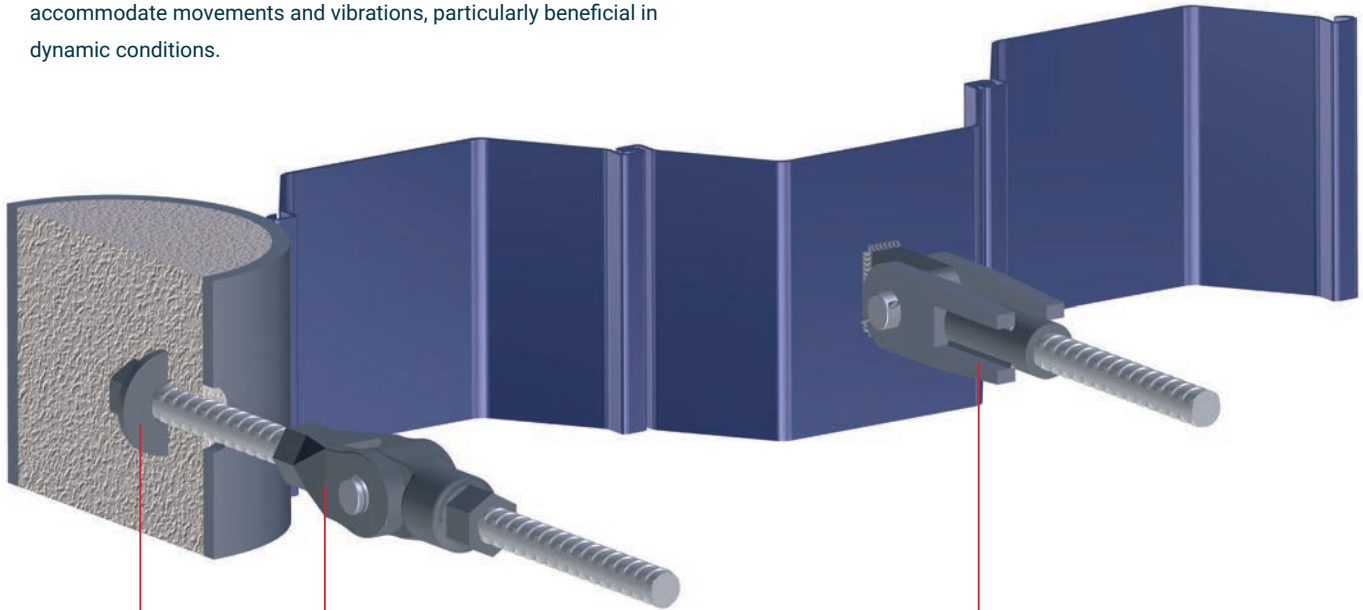

Anchorage in concrete or drilled pile with articulated connection

Articulated connection with sheet pile wall using welding plate and clevis

Couplers and connections

We offer a wide range of couplers and connections to suit various project requirements.

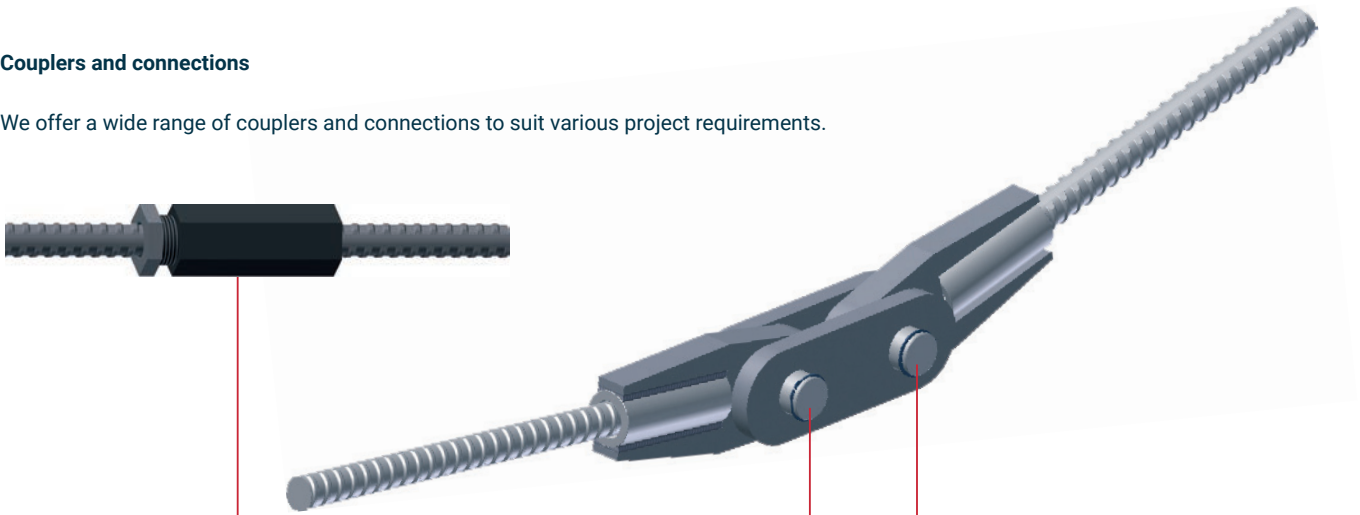

Turnbuckle with length compensation

Double strap articulation with eye pieces and exterior straps

DYWIDAG Tie bars - GEWI® and GEWI® Plus

Waler bolt

Waler bolts are used in construction projects to secure and connect walers, which are horizontal beams or bars.

These bolts are typically made of durable materials like steel and are strategically positioned and fastened to anchor and connect walers to vertical structures such as retaining walls or sheet pile walls.

By distributing and transferring loads evenly across the structure, waler bolts help reinforce and stabilise the construction, ensuring its long-term stability and integrity.

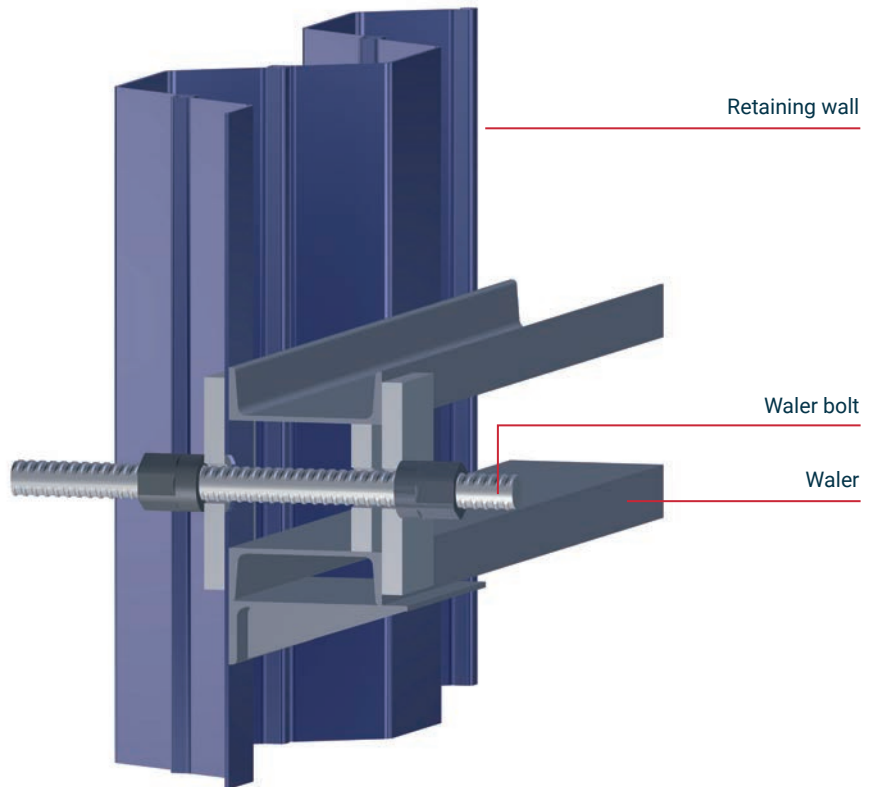

Welded-in waler bolt

Welded-in waler bolts are a type of waler bolt that is permanently welded into position during construction. These bolts are typically made of high-strength steel and are welded directly onto structural members or steel plates embedded within concrete.

Welded-in waler bolts provide a secure and durable connection between the waler and the structure, enhancing stability and load-bearing capacity.

They are commonly used in applications where a robust and permanent connection is required, such as in the construction of retaining walls, bridge abutments, or marine structures.

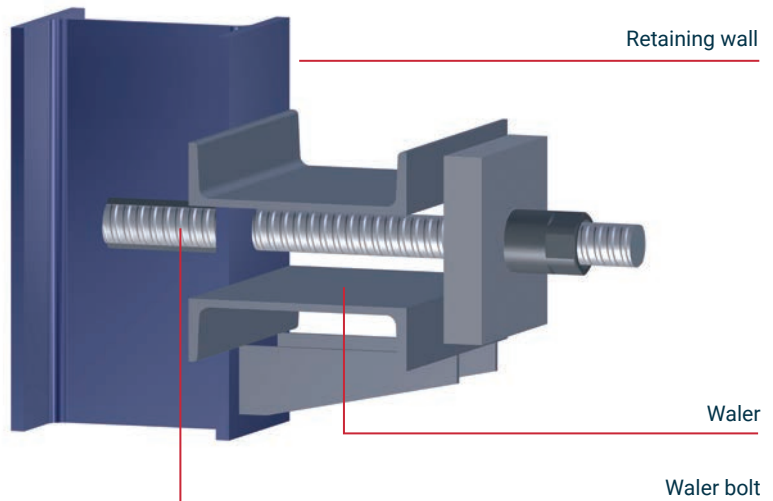

Revival of Stonehaven Harbour's ageing pier infrastructure



Owner: Aberdeenshire Council

General contractor: TMS Maritime Ltd

Products supplied: 50mm GEWI® Tie bar

Port of Middlesbrough quay wall repair



Owner: AV Dawson Ports

General contractor: TMS Maritime Ltd

Products supplied: 63.5mm GEWI® Tie bar and gusseted plates

Stressing and testing services

At DYWIDAG, we perform a range of tests to guarantee the quality and efficacy of our products and solutions. On-site testing is pivotal in validating the performance of the DYWIDAG anchoring system and affirming the quality and suitability of the proposed design.

Depending on the application, the selection of the appropriate test method is crucial. Certain tests, particularly rigorous ones, are conducted on sacrificial trial elements, which are installed as replicas of the working tendons.

The testing of ground anchors typically encompasses three main categories of tests:

Investigation tests

Conducted on trial anchors and tested to failure, these assessments determine the pullout resistance, aiding in the selection of a suitable design load for the anchored structure.

Additionally, they verify that the anchor is securely bonded into the strata at an appropriate distance from the structure to maintain stability. These tests are carried out on sacrificial or working anchors, serving as a reference for measuring the performance of the working anchors. They document the ability to withstand proof loads and assess parameters such as creep rate, load loss, and apparent free length.

Suitability tests

These tests are conducted on sacrificial or working anchors to establish a benchmark against which the performance of the working anchors can be evaluated, documenting their ability to withstand proof loads, assess creep rate or load loss, and determine apparent free length parameters

Acceptability tests

Each test involves loading and unloading cycles, gradually increasing to a predetermined load using a stressing jack tailored to the chosen test method and the capacity of the structural tendon. Upon completion of the test, if specific tolerances are met, the anchor can be locked off at a known load, serving as a reference point for future monitoring.

Testing and monitoring offer economic benefits throughout the tendon's service life. Insights gained from in-situ tests and trials allow for an optimised assessment of the construction design. Regular monitoring and inspection contribute to extending the service life of both the tendon and the entire retaining structure by enabling the early detection of defects or damage.

- Further information can be found in relevant codes and standards such as BS8081:2015.
- Conducted on working anchors to ensure construction methods and safety.
- To document the ability to resist a proof load.
- To assess creep rate or load loss.
- To assess apparent free length parameters.

DYWIDAG also offer a range of manual and hydraulic torque equipment. These units provide testing for the complete GEWI® range and are ideal in providing regular testing and minimisation of slippage in anchor threadbar connections and increases fatigue resistance.

We offer a complete package of measuring equipment for monitoring and tensioning during performance and proof tests, including both analogue and digital load cells.





Other products and services by DYWIDAG



Structural health monitoring

Automated and manual monitoring including survey. Supply and installation of automated and manual monitoring and survey systems, this data can also be viewed on our infrastructure intelligence platform.



Concrete technologies

Permanent formwork systems and slab edge forms, form ties, reinforcement technologies - stop ends and starter packs, concrete accessories, sealing and chemical solutions.



Stay cables including monitoring and inspection

Design and installation of stay cable systems plus the monitoring and inspection using robotic inspection methods.



Infrastructure Intelligence

Data acquisition platform, automated alarms and alerts, bespoke tailored system to suit your project.



Repair and refurbishment

Testing and repair of existing ground anchors, refurbishment of post-tensioning systems to existing structures, rope access and wrapping of stay cables.



Post-tensioning systems

Manufacture and installation of bonded and un-bonded post tensioning systems.



Get in touch.

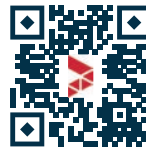

DYWIDAG Ltd
Northfield Road
Southam
Warwickshire
CV47 0FG

sales.uk@dywidag
Tel: +44 2475 382 547