

COUNTRY CLUB AUTO DETAIL, INC.
3958 S. Kalamath St.
Englewood, CO 80110
(303) 761-1245

Niel Jones
3989 S. Lipan St., Ste. 1000
Englewood, CO 80110

9~~2~~ December 1993

Thoroughly washed car, wet sand front fenders, parts of hood, rear fenders and other areas as needed. Buffed twice. Wax and buffed again with special wax.	10.0 hrs.
Remove running boards and completely stripped them of chipped paint and rust. Primed and painted.	4.0 hrs.
Sanded and buffed running boards.	1.0 hr.
Filed and polished aluminum strips that attach to running boards	1.0 hr.
Purchased new brass screws and filed them so the tops were rectangular in order to allow them to slide into the grooves and attach the strips. Replaced rusted screws on boards with new brass screws to attach to car.	2.5 hrs.
Repaired and painted small section between bottom of doors and running boards. This included the rust holes filled, primed and sanded.	2.0 hrs.
Reinstalled new rubber fender welt next to boards. Reinstalled the running boards - used new rubber bushings on right side (originals missing)	3.5 hrs
Brush touched chips in paint around car. Removed the wheels - painted brake drums w/matching body color. Painted frame rails black. Lightly undercoated wheel wells. ; Cleaned and dressed and replaced wheels. Hand rubbed final coat of wax on exterior paint. Polished all exterior chrome and aluminum. Cleaned windows.	8.0 hrs.
Scrubbed interior: doors, seats, floors, headliner. Cleaned and polished dash and all metal parts.	<u>2.0 hrs.</u>

35 hours @ \$40.00

\$1,400.00

COUNTRY CLUB AUTO DETAIL, INC.
3958 S. Kalamath St.
Englewood, CO 80110
(303) 761-1245

Niel Jones
3989 S. Lipan St., Ste. 1000
Englewood, CO 80110

Leather Dyes:

Removed seats front and rear, applied crack fill
as needed. Dye front and rear seats. Dyed all
leather around window frames.

Total Leather Dye		\$360.00
Materials for leather dye and detail and paint		136.50
	Tax	<u>9.96</u>
BALANCE DUE		\$1,906.46

Paid
Ch 5273
12/9/93



002776

CHIEF
AUTOMOTIVE SYSTEMS, INC.

THREE R AUTOMOTIVE, INC.
QUALITY BODY & FRAME

sikkens
CAR REFINISHES

Reproduction • Restoration • Racing

3858 S. Kalamath • Englewood, CO 80110 • (303) 781-0774

Page of pages

NAME <i>NEIL JONES</i>		PHONE W H		DATE
STREET		CITY, STATE, ZIP		
YEAR	COLOR <i>BLUE</i>	MAKE <i>TRABBIT</i>	MODEL	
VEHICLE IDENTIFICATION NUMBER (VIN)		DATE OF LOSS	ODOMETER	ESTIMATE PREPARED BY
INSURANCE CO.		ADJUSTOR		

REPLACE	REPAIR	DESCRIPTION	PARTS	LABOR	REFINISH	SUBLET
		<i>GRILLE REPAIR</i>				
		<i>DISASSEMBLY</i>				
		<i>REPAIR VERTICALS</i>				
		<i>MAKE NEW CIRCLE (HOLE)</i>				
		<i>Blast & CLEAN</i>				
		<i>PRIME & PAINT BEIGE SILVER</i>				
		<i>REASSEMBLE</i>				

10/2/93
CH # 5237

AUTHORIZATION FOR REPAIR

You are hereby authorized to make the above repairs:

SIGNED: _____

DATE: _____

AUTHORIZATION FOR SUPPLEMENT PAYMENT

I, X

hereby authorize _____ insurance company to pay any additional costs or supplements directly to **THREE R AUTOMOTIVE, INC.**

DATE: _____

BODY LABOR	<i>4 1/2 hrs</i>	<i>140 00</i>
FRAME LABOR		
PAINT LABOR	<i>1 1/2 hrs</i>	<i>52 50</i>
SUBLET		
TOW		
PARTS		
MATERIAL		<i>25 50</i>
TAXABLE SUBTOTAL		
TAX		
TOTAL		<i>218 00</i>

T's SUNRISE
 3975 S. Lipan Street
 ENGLEWOOD, COLORADO 80110
 (303) 761-6785

CUSTOMER'S ORDER NO.		PHONE		DATE		
				9-23-93		
NAME Neil Jones						
ADDRESS 48 Talbot Lago						
SOLD BY	CASH	C.O.D.	CHARGE	ON ACCT.	DISC. RETD.	PAID OUT
QTY.	DESCRIPTION			PRICE	AMOUNT	
	Steering, Carbs, Rad, tank			26	1040.00	
	Brakes					
	Steam, Remove Brakes			13	520.00	
	Overhaul Cylinders, Master			12	480.00	
	assemble hubs, Bearings, Linds			7	280.00	
	Install Tank, Bleed, Tune			12	480.00	
	Trans, Rocker shafts			15	600.00	
	Repair Wires, Radio			16	660.00	
	Total Labor				4060.00	
	Parts				676.00	
	Add'l repair part				out side Labor	
					587.00	
	Gas				30.00	
	Tax				49.35	
					5702.35	
	Less Deposits			TAX	4000.00	
RECEIVED BY	JO 9/23/93 - ck# 5228 →			TOTAL	1702.35	

All claims and returned goods
 MUST be accompanied by this bill.

Thank You

1145

NEIL E. JONES 5-74
SPECIAL ACCOUNT

5206

PHONE 303 761-3088
3989 SOUTH LIPAN STREET SUITE 1000
ENGLEWOOD, CO 80110

23 Aug 1993

82-481/1070

PAY TO THE
ORDER OF

T's Sunrise

\$ 2000⁰⁰

Two Thousand and no/100 DOLLARS



First Interstate Bank
of Englewood, N.A.
3333 South Bannock
Englewood, CO 80110
Account Information (303) 292-5100

FOR

re Talbot Jago

Neil E Jones

⑆ 107004815⑆ 225 113 21⑆ 5206

T's SUNRISE
 3975 S. Lipan Street
 ENGLEWOOD, COLORADO 80110
 (303) 761-6785

CUSTOMER'S ORDER NO.		PHONE		DATE	
				6-14-93	
NAME Neil Jones					
ADDRESS 48 Talbot Lago					
SOLD BY	CASH	C.O.D.	CHARGE	ON ACCT.	MDSE. RET'D.
QTY.	DESCRIPTION			PRICE	AMOUNT
	Radio Repair				375.00
	Show quality Resto on wheels 85.00 Ea				425.00
					<hr/>
					800.00
RECEIVED BY				TAX	
				TOTAL	

Paid
5175

1123

All claims and returned goods
 MUST be accompanied by this bill.

Thank You

T's SUNRISE
 3975 S. Lipan Street
 ENGLEWOOD, COLORADO 80110
 (303) 761-6785

CUSTOMER'S ORDER NO.		PHONE		DATE		
				10-30-92		
NAME Neil Jones						
ADDRESS 1948 TALBOT LAGO RECORD						
SOLD BY	CASH	C.O.D.	CHARGE	ON ACCT.	MDSE. RET'D.	PAID OUT
QTY.	DESCRIPTION				PRICE	AMOUNT
5	Michelin 600x18 tires @ \$234 ⁰⁰ ea. freight from TN					1,170 ⁰⁰ 50 ³⁵
5	Wheels restored to show quality @ \$385 ⁰⁰ ea.					1,925 ⁰⁰
5	Knock offs restored @ \$50 ⁰⁰ ea.					250 ⁰⁰
5	Boxes + freight to OHio					85 ⁰⁰
	Labor					80 ⁰⁰
	Paid # 5060					
					TAX	85 ⁴¹
RECEIVED BY					TOTAL	3,645 ⁷⁶

All claims and returned goods
 MUST be accompanied by this bill.

Thank You

1090



First Interstate Bank
of Denver, N.A.

FIRST INTERSTATE BANK OF ENGLEWOOD
Englewood, Colorado

N2 FD 23674

June 24, 1992
DATE

L7-1052 (9/83) Replaces C51095

HAS RECEIVED THE AMOUNT SHOWN BELOW FOR CHECK
PURCHASED IN FAVOR OF ****CLUB TALBOT*****

300FR**
AMOUNT OF CHECK IN FIGURES

FOR ****THREE HUNDRED FRENCH FRANCS*****

DRAWN ON Societe Generale de Paris
ON DAIT Group Correspondants No.1
ADDRESS 30, Avenue Victor Hugo
75016 Paris
FRANCE

THIS CHECK IS SOLD SUBJECT TO THE CONDITIONS
STATED ON THE REVERSE SIDE.

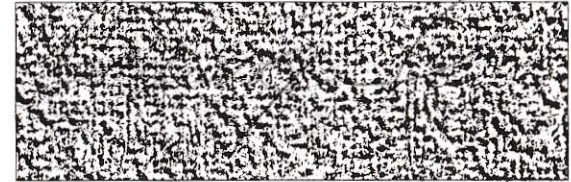

PURCHASER:
ADDRESS:

Neil Jones

REMITTED RATE	U.S. DOLLAR EQUIVALENT	AIR MAIL CHARGE	COMMISSION CHARGE	AMOUNT REMITTED
.1937	58.11	nc	11.00	69.11

ADVICE TO PURCHASER:

TO ENSURE DELIVERY TO THE
PROPER PERSON, WE SUG-
GEST THAT THIS CHECK BE
FORWARDED BY REGISTERED
MAIL.

NOT NEGOTIABLE
PURCHASER'S RECEIPT

SALES ORDER

T'S SUNRISE
3975 S. Lipon Street
Englewood, CO 80110

No 1676

(303) 761-6785

Customer's Order No. _____ Date 8.20.10
Name Neil Jones
Address _____
French Car

SOLD BY	CASH	C.O.D.	CHARGE	ON ACCT.
QTY	DESCRIPTION	PRICE	AMOUNT	
	Labor for fan		300 00	
	Parts		170 00	
	<u>EXTRA COOLING FAN</u>	Tax	13 35	
	Gas		24 00	
	<u>JA 8/20/10</u>			
	<u>ch # 3062</u>			
			<u>507 35</u>	

ALL claims and returned goods MUST be accompanied by this bill.

Received by _____

Thank You!



Classic Restoration by Country Club Auto
 3800 S Kalamath
 Englewood, CO 80110
 303-761-1245

Invoice

Date	Invoice #
8/21/2009	2162

TO:
Niel Jones

JOB	TERMS	DUE DATE
Talbo Lago	Due on Receipt	8/21/2009

Description	Qty	Rate	Amount
TWO STAGE BUFF ON EXTERIOR PAINT: First Stage: buff with a finishing compound and a new white pad to remove oxidation as possible Second Stage: buff with finishing polish and white foam pad to shine & polish Hand wax complete exterior & door jambs Clean & polish windows	5	85.00	425.00
Detail Materials		20.00	20.00T

Sales Tax (7.85%)		\$1.57
Total		\$446.57

RÉPERTOIRE CLUB TALBOT

DOMINIQUE DUPONT - 440 RUE HENRY MILLEZ - 59830 LOUVIN - FR - TEL 0320 795 550 - FAX 0386 976 214

ATTENTION : Changement d'adresse ci-dessus (fax provisoire)

Claude L.P. Schmitt
46 Blvd d'Alsace
06400 CANNES / Fr
Tel 0493 392 069

Cher ami Talbotiste,

La charge d'informatiser le Registre Talbot m'est échue. Plus de mille deux cent de nos Belles de Suresnes sont saisies. Ceci permettra une mise à jour régulière des informations dont l'intérêt multiple ne vous échappera certainement pas, ne serait-ce qu'en cas de vol. Bien entendu, pour que mon travail soit le plus précis possible j'ai besoin de votre aide. Merci donc de bien vouloir me retourner la ou les fiches que vous trouverez en annexe avec les corrections et/ou les compléments nécessaires à mon adresse de Cannes.

For our friends "Talbotistes" who are not fluent in our French language, briefly, the present intends to update the Talbot Register information. It would be kind of you to return at my Cannes address the file(s) that you will find herewith. Obviously, the accuracy of the files depends on your answer. Thank you in advance.

Claude L.P. Schmitt

NUMÉRO DE FICHE	976	DATE MISE À JOUR	17/01/98	64
STATUT	TALBOT	DATE CRÉATION	17/01/98	
NOM FAMILLE	JONES			ADRESSE <small>ADOK = adresse OK - MAD = mauvaise adresse</small> <input checked="" type="radio"/> ADOK <input type="radio"/> MAD
PRÉNOMS	Neil O.			
ADRESSE, N°, rue	3989 S. Lipan St. - Suite 1000			MAILING <small>MAIL = OK envoi - STOP = Pas d'envoi</small> <input checked="" type="radio"/> MAIL <input type="radio"/> STOP
CODE POSTAL	COL 80110			
VILLE	ENGLEWOOD			ARCHIVES <small>ACT = ne pas archiver - ARKV = archiver</small> <input checked="" type="radio"/> ACT <input type="radio"/> ARKV
PAYS	U S A			
TEL N°1	001 303 761 3088			
TEL N°2				
TEL N°3				
FAX				
REMARQUES	L 5/92			



CLUB TALBOT

440 rue Henry Millez - 59830 LOUVIN - Fr - Tel 0320 795 550

ATTENTION : NOUVELLE ADRESSE

LOUVIN le 25 Janvier 1998

Cher ami Talbotiste,

Même si j'y ajoute un bilan, la présente a essentiellement pour but de vous présenter mes meilleurs voeux à l'occasion de la nouvelle année s'il en est encore temps (retard dû à l'important travail d'informatisation de nos fichiers). Voeux de bonheur à vous et à vos proches, mais aussi voeux de longue vie à nos chères Talbot. Vous vous joindrez certainement à moi pour formuler également nos voeux de prospérité pour notre Club.

Vous savez que j'assume, pratiquement seul, la lourde responsabilité du Club Talbot depuis quatorze ans. Ma véritable passion pour cette marque prestigieuse n'a cessé de se renforcer malgré le poids de cette tâche. Nous avons connu de grands plaisirs lors de rallyes inoubliables. Nous avons été présents à Rétromobile presque sans interruption. Le Registre de la marque qui s'enrichit de jours en jours, est maintenant informatisé. Enfin, la grande majorité des recherches de pièces et autres documentations est toujours honorée. Ce qui donne quand même un aspect assez satisfaisant à mon bilan et j'ose espérer que vous m'en donnerez acte.

Cependant, tout bilan a son passif et l'évoquer ici peut également se concevoir comme le voeu de ne plus avoir à l'évoquer à nouveau l'année prochaine. Cette année 97 a malheureusement été marquée d'un grand regret. Nos amis Jean Claude Caveng et Henri Maulet nous avaient concocté un super rallye dans une région superbe et à un prix défiant toute concurrence. Faute de combattants, (7 postulants seulement), leurs efforts se sont révélés vains et l'annulation inévitable est venue ternir notre enthousiasme. Par ailleurs, en 96 le nombre d'adhérents du Club avait pratiquement été divisé par deux, autre déception que j'avais eu un moment la faiblesse d'imputer à notre absence de Rétromobile 96. Notre présence en 1997 nous a permis de remonter le nombre des adhérents à 130, ce qui n'est toutefois pas un grand succès pour le club d'une marque prestigieuse dont près de mille survivantes ont été dénombrées. La santé d'un club dépend d'abord de la volonté des adeptes de la marque. Je forme alors un autre voeu, celui de vous voir rejoindre nombreux les fidèles du Club Talbot afin de rompre ce cercle vicieux : moins de Rétromobile impliquerait moins de Membres, mais aussi, moins de Membres impliquerait moins de Rétromobile.

D'où la décision prise de ne pas être présent à Rétromobile 1998, "juste pour voir". Le retour des bulletins d'adhésion que vous trouverez en annexe sera déterminant pour les perspectives auxquelles nous aspirons. Dès que possible nous vous informerons sur l'organisation du Rallye 1998 et son degré de succès comportera un second éclairage sur l'avenir du Club.

Pour ma part, je continuerai la tâche que je considère comme primordiale, celle de dépanner les propriétaires en pièces et documents de manière à ce que la Talbot roule et fasse partie du patrimoine à titre définitif.

Il faut sauver toutes les voitures qui existent encore afin de les transmettre à la postérité.

Très amicalement vôtre

Dominique Dupont
Président du Club Talbot

DÉTAILS DE CONSTRUCTION CARROSSERIE

COMMANDE N° *101035*

CARROSSERIE N° *537*

Type de carrosserie	<i>Conduite intérieure</i> <i>332</i>	PARTICULARITÉS
Peinture	<i>Bleu 126</i> <i>Pneus rudge chromées</i>	
Accessoires	<i>Clé de porte 5448</i> <i>Clé de malle 3886</i> <i>Clé de contact 660</i> <i>Appareil de chauffage</i> <i>Boîte de radios Philips 70762</i>	
Garnitures	<i>cuir bleu 1014</i>	
		<i>Neus Dunlop 600x1.</i> <i>128000920</i> <i>20010760</i> <i>128032548</i> <i>128036367</i> <i>128060707</i>

NOM DU CLIENT *M. cur Epailly*

SERVICE DE GARANTIE

Date de livraison *le 13 juillet 1950*

Expiration de la garantie Garantie de

REPLACEMENTS

SOUS GARANTIE

HORS GARANTIE



DÉTAILS DE CONSTRUCTION CHASSIS

CHASSIS N° 3501

VOITURE N° 101035

<p>Moteur No <u>26504</u> Type</p>	<p>Culasse No <u>95-83755</u> Cylindre No <u>83753</u> Pistons No <u>Borgo 85030</u> Bielles No <u>84572</u> Vilebrequin No <u>84863</u> Génératrice marque <u>Paris Pléone</u> No Delco " <u>SEV</u> No Carburateur " <u>Jeuth</u> No Embrayage No Particularité du moteur <u>Segments scania</u></p>	<p>Châssis Longerons No Berceau No Accu No <u>Manopleque</u> Particularités</p>
<p>Boîte de vitesse No <u>3542</u></p>	<p>Carter boîte No <u>12439</u> Carter embray. No <u>84051</u> Plateau accoupl. No <u>84936</u> Pignon Particularité</p>	<p>Ressorts AV No <u>84144</u> AR No <u>86060</u> Particularités</p>
<p>Pont AR No <u>3508</u> Type</p>	<p>Multiplication <u>12x43</u> Roue <u>3.62x8</u> type <u>Wedge Promico</u> Moyeu No type : Plateau accoupl. No <u>84937</u> Marque roulements <u>Lumber</u> Marque acier Freins marque <u>Loospeed</u> type : Particularité du pont :</p>	<p>Amortisseurs AV No <u>84248-49</u> AR No <u>86767-62</u> Particularités</p>
<p>Essieu AV No</p>	<p>Corps d'essieu No Fusée No <u>84849-48</u> Tambour No <u>84009</u> Freins <u>Loospeed</u> No Particularités</p>	<p>Radiateur No <u>84716</u> Marque <u>Chauoron</u> Particularités</p>
<p>Direct No</p>	<p>Carter No <u>84737</u> Particularités</p>	<p>Réservoir No <u>82904</u> Type Particularités</p>
<p>Essieu AV No</p>	<p>Corps d'essieu No Fusée No <u>84849-48</u> Tambour No <u>84009</u> Freins <u>Loospeed</u> No Particularités</p>	<p>Démarreur No Marque <u>Paris Pléone</u> Particularités</p>
<p>Direct No</p>	<p>Carter No <u>84737</u> Particularités</p>	<p>Tablier No <u>84934</u> Type Particularités</p>
<p>Direct No</p>	<p>Carter No <u>84737</u> Particularités</p>	<p>Tableau électrique Marque Particularités</p>

DR 2001 (08/31/06)

STATE OF COLORADO
CERTIFICATE OF TITLE
****MOTOR VEHICLE****

TITLE NUMBER
10P534874

ODOMETER
0

ODOMETER LEGEND:
A - Actual Mileage
E - Exceeds mechanical limits
N - Not actual mileage; WARNING
ODOMETER DISCREPANCY

VIN
T26101035
MAIL TO

YEAR MAKE MODEL
1953 TAL

BODY
4D



JONES NEIL E
4997 TULE LAKE DR
LITTLETON, CO 80123-2753

CWT/CAP/SIZE

CWT 16
PREVIOUS TITLE

11C338750
FUEL

GAS

DATE PURCHASED

01/28/1992

DATE ACCEPTED

01/31/1992

DATE ISSUED

10/06/2008

OWNER
JONES NEIL E

FIRST LIENHOLDER

DATE RCD

Signature below certifies under penalty of perjury in the second degree the release of the first lienholder's interest in the vehicle.

FILE NUMBER

Lienholder's Name

AMOUNT OF LIEN

LIEN EXTENDED TO COUNTY

MATURITY DATE

Authorized Agent's Signature Date

SECOND LIENHOLDER

DATE RCD

Signature below certifies under penalty of perjury in the second degree the release of the second lienholder's interest in the vehicle.

FILE NUMBER

Lienholder's Name

AMOUNT OF LIEN

LIEN EXTENDED TO COUNTY

MATURITY DATE

Authorized Agent's Signature Date

THIRD LIENHOLDER

DATE RCD

Signature below certifies under penalty of perjury in the second degree the release of the third lienholder's interest in the vehicle.

FILE NUMBER

Lienholder's Name

AMOUNT OF LIEN

LIEN EXTENDED TO COUNTY

MATURITY DATE

Authorized Agent's Signature Date

FOURTH LIENHOLDER

DATE RCD

Signature below certifies under penalty of perjury in the second degree the release of the fourth lienholder's interest in the vehicle.

FILE NUMBER

Lienholder's Name

AMOUNT OF LIEN

LIEN EXTENDED TO COUNTY

MATURITY DATE

Authorized Agent's Signature Date

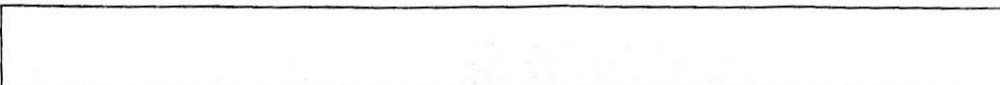

THE APPLICANT HAS BEEN DULY REGISTERED IN THIS OFFICE AS THE OWNER OF THE MOTOR VEHICLE DESCRIBED,
SUBJECT TO LIENS AND ENCUMBRANCES IN THE ORDER SHOWN.

EXECUTIVE DIRECTOR, COLORADO DEPARTMENT OF REVENUE DATE DUPLICATE ISSUED

ROXY HUBER

H5295757

KEEP IN SAFE PLACE - ANY ALTERATION OR ERASURE VOIDS THIS TITLE

REV. 10/9/06

VOID IF ALTERED

COLORADO CERTIFIED VIN INSPECTION §42-5-202, CRS

**NOTICE: ANY ALTERATION OR ERASURE VOIDS THIS DOCUMENT.
 ALL FIELDS ON THIS FORM MUST BE COMPLETED. IF INFORMATION REQUESTED DOES NOT APPLY, PLEASE INDICATE N/A.**

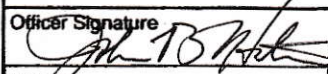
<input type="checkbox"/> Bond <input type="checkbox"/> Salvage <input type="checkbox"/> In Lieu of Bond		<input type="checkbox"/> Colorado Assigned VIN <input type="checkbox"/> Homemade <input type="checkbox"/> Reconstructed			<input type="checkbox"/> Rebuilt/Street Rod <input type="checkbox"/> Kit <input type="checkbox"/> VIN Altered			<input checked="" type="checkbox"/> Other Title Correction											
Public VIN	T	2	6	1	0	1	0	3	5										
CVIN	3	5	0	1															
Federal Cert. Sticker VIN																			
Other VIN																			
Vehicle Year	1953	Make	Tabot Lago	Model	Record	Body Style	4D / T-26	Color	Blu	Odometer	47601								
License Plate No.	83C40	State	CO	Exp. Date	09/2013	Title No.	10P534874	State	CO	Fuel	<input checked="" type="checkbox"/> Gasoline	<input type="checkbox"/> Diesel	<input type="checkbox"/> Other						
Title/Registration Name	Jones, Neil E					Address					4997 Tole Lake Drive								
City	Littleton		State	CO		ZIP	80123		Home Phone			Work Phone	303-761-3088						
Inspection for (if other than above)	Title Correction					Address													
City			State			ZIP			Home Phone			Work Phone							
NCIC/CCIC Clear	<input checked="" type="checkbox"/> Yes	<input type="checkbox"/> No	VIN match docs.	<input checked="" type="checkbox"/> Yes	<input type="checkbox"/> No	VIN OK, no docs.	<input type="checkbox"/> Yes	<input type="checkbox"/> No	Engineer's Report Recommended	<input type="checkbox"/> Yes	<input checked="" type="checkbox"/> No	Other, Explain below							
Comments/Explanations Vin on title is listed as: P26101035 (to Title 10P534874) Vin on described vehicle is: T26101035, which matches associated documentation, and vehicle history. Error in VIN appears since 1961 Title transfer from Dabney T Collins to Hayes P. Lyon. The vehicle appears to be true original manufacture with no significant alteration or reconstruction. Identifiable numbers match manufacturer's build sheet.																			
I certify under penalty of perjury that I physically examined the vehicle described above and the information is true and correct to the best of my knowledge. This inspection verified the vehicle identity only, and that it is equipped pursuant to Colorado Revised Statutes. The inspector is not an automotive engineer and no representation is made relative to handling, braking, center of gravity or unibody integrity that may have been affected by the repair, construction, assembly or rebuilding of the vehicle.																			
Officer Signature						VIN Insp	0357			Print Name	John B. Hallsten			Date	9-26-08				
Agency	Arapahoe P.D.			Address	5900 S. Santa Fe Dr.			City	Littleton		State	CO		ZIP	80120				

CERTIFICATION OF VITAL RECORDS

STATE OF COLORADO

DATE REGISTERED BY STATE REGISTRAR
JAN 13 1988

05935

STATE OF COLORADO
CERTIFICATE OF DEATH
(PHYSICIAN OR CORONER)

87020053

STATE FILE NUMBER

ORADO
HEALTH
16
1-78)
S IS A
ANENT
CORD
LACK INK
EWRIER
BLACK
BON
UAL
DENCE
ERE
EASED
VED
EATH
URRED
TUTION
IVE
DENCE
FORE
SSION

DECEASED—NAME 1 Hayes Paxton LYON		SEX 2 Male	DATE OF DEATH (MONTH, DAY, YEAR) 3 December 30, 1987
RACE (White, Black, American Indian, etc.) 4a White	ORIGIN OR DESCENT (Italian, Mexican, English, etc.) 4b English	AGE—LAST BIRTHDAY (Years) 5a 78	DATE OF BIRTH (MONTH, DAY, YEAR) 6 Feb. 10, 1909
CITY, TOWN OR LOCATION OF DEATH 7a Denver	HOSPITAL OR OTHER INSTITUTION—Name (if not in either, give street and number) 7c Veteran's Administration Hospital	IF HOSP. OR INST. OP: Emer. Rm., Inpatient (Specify) 7d Inpatient	
STATE OF BIRTH (if not in U.S.A. name country) 8 Kansas	CITIZEN OF WHAT COUNTRY 9 U.S.A.	MARRIED, NEVER MARRIED, WIDOWED, DIVORCED (Specify) 10 Married	SURVIVING SPOUSE (if wife, give maiden name) 11 Oma Ray Walker
SOCIAL SECURITY NUMBER 13 521-12-4467	USUAL OCCUPATION (Give kind of work done during most of working life even if retired) 14a Artist	KIND OF BUSINESS OR INDUSTRY 14b Self Employed/Art	
RESIDENCE—STATE 15a Colorado	COUNTY 15b Jefferson	CITY, TOWN OR LOCATION 15c Arvada	ZIP 15d 80005
STREET AND NUMBER 15e 10105 West 78th Avenue		INSIDE CITY LIMITS (Yes or No) 15f Yes	
FATHER—NAME 16 Willis Hayes Lyon	MOTHER—NAME 17 Vinnie Paxton	INFORMANT—NAME 18a Oma Ray Lyon	
Relation to Deceased 18b wife		MAILING ADDRESS (STREET OR R.F.D. NO. CITY OR TOWN STATE ZIP) 18c 10105 West 78th Ave., Arvada, Colorado 80005	
BURIAL, CREMATION, REMOVAL (Specify) 19a Burial	DATE (Month, Day, Year) 19b Jan. 5, 1988	CEMETERY OR CREMATORY—NAME AND LOCATION 19c Crown Hill Cemetery Jefferson County Colorado	
FUNERAL DIRECTOR 20a Leonard J. Lyngby	NAME AND ADDRESS OF FUNERAL HOME (STREET OR R.F.D. NO. CITY, STATE, ZIP) 20b CROWN HILL CEMETERY & MORT. 7777W. 29th Ave. Den. CO 80215		
21a. PHYSICIAN TO THE BEST OF MY KNOWLEDGE, DEATH OCCURRED AT AND DUE TO THE CAUSE(S) STATED		21b. CORONER—ON THE BASIS OF EXAMINATION AND/OR INVESTIGATION, IN MY OPINION DEATH OCCURRED AT AND DUE TO THE CAUSE(S) STATED	
DATE SIGNED (Month, Day, Year) 21c Jan. 4, 1988		DATE SIGNED (Month, Day, Year) 21d Dec. 30, 1987 8:41 AM	
NAME AND ADDRESS OF CERTIFIER (PHYSICIAN OR CORONER) (Type or Print) 22 Triena M. Harper 431 Violet Street Golden, Colorado 80401			
REGISTRAR 23a (Signature) Ernie J. Cook Deputy		DATE RECEIVED BY REGISTRAR (Month, Day, Year) 23b JAN - 8 1988	
25. PART I IMMEDIATE CAUSE (ENTER ONLY ONE CAUSE PER LINE FOR (a), (b), OR (c))			
(a) DUE TO, OR AS A CONSEQUENCE OF		Respiratory Failure	
(b) DUE TO, OR AS A CONSEQUENCE OF		Acute suppurative tracheo bronchitis and	
(c) UNDERLYING CAUSE LAST		Bronchio-pneumonia	
PART II OTHER SIGNIFICANT CONDITIONS—Conditions contributing to death but not related to cause given in PART I (a)		AUTOPSY (Yes or No) 26 Yes	
Postmortem Ex T-2, ASHP, Swere		WAS CASE REFERRED TO CORONER (Yes or No) 27 Yes	
ACCIDENT, SUICIDE, HOMICIDE, UNDETERMINED, PENDING INVESTIGATION.		DATE AND HOUR OF INJURY (Mo. Day, Yr., Hr.)	
28a		28b	
INJURY AT WORK (Yes or No) 28c		PLACE OF INJURY—At home, farm, street, factory, office, building, etc. 28d	LOCATION (STREET OR R.F.D. NO., CITY OR TOWN, STATE) 28e

THIS IS TO CERTIFY THAT THIS IS A TRUE AND CORRECT COPY OF THE OFFICIAL RECORD WHICH IS IN MY CUSTODY.

DATE ISSUED **JUN 07 1991**

Joseph D. Carney
JOSEPH D. CARNEY
STATE REGISTRAR

Do not accept unless prepared on security paper with engraved border displaying the Colorado state seal and signature of the Registrar. PENALTY BY LAW, Section 25-2-118, Colorado Revised Statutes, 1982, if any person alters, uses, attempts to use or furnishes to another for deceptive use any vital statistics record. NOT VALID IF PHOTOCOPIED.

VR 100S 8/88

SL253126



MOTOR VEHICLE BILL OF SALE

Date: January 28, 1992

In consideration of 18,000 dollars, the receipt whereof is hereby acknowledged, do hereby bargain, sell and deliver unto

Neil E. Jones of Littleton, Colorado.

One Talbot Rage (Make) vehicle.

Identification No. VIN 101030 Year 1953 Model Record.

To have and to hold the said vehicle unto the said purchaser to their own use and benefit forever.

I (We) do vouch to be the true and lawful owner(s) of said vehicle, the same is free and clear of all liens and encumbrances, and that I (we) have full power, right and lawful authority to dispose of this vehicle, as aforesaid, and that I (we) will warrant and defend the same against the lawful claims of all persons.

I SWEAR UNDER PENALTY OF PERJURY THAT THE FACTS STATED ABOVE ARE TRUE AND CORRECT TO THE BEST OF MY (OUR) KNOWLEDGE.

Oma Ray Lynn
Signature of Seller
10105 West 78th Avenue
Arvada, Colorado 80005
Address/City, State

Signature of Seller
Address/City, State

COLORADO REGISTRATION/OWNERSHIP TAX RECEIPT									
TYPE	PLATE	TAB/VAL	VIN		EXPIRE				
TITLE RECEIPT ONLY			P26101035						
TITLE	YR.	MAKE	BODY	SERIES	MODEL	CWT/PASS	FLEET#		
10P534874	53	TAL	4D			16	C		
PUR. DATE	PUR. PRICE	ORIGINAL TAXABLE VALUE		BUS. DATE	CO.#	U/R CODE			
01/28/92	18000.00	8,000		01/31/92	10	U 0001			
PREV. EXP.	PRIOR O.T.	OWN. TAX	LIC. FEE	TITLE FEE	OTHER FEE				
	0.00	0.00	0.00 E	5.50	0.00				
RTD TAX	COUNTY TAX	CITY TAX	STATE TAX	SPECIAL FEE	FUEL				
144.00	0.00	540.00	540.00		0.00 G				
UNIT#	GVW	MILES		HC DATE					
MOTOR VEHICLE INSURANCE IS COMPULSORY IN COLORADO, NON-COMPLIANCE IS A MISDEMEANOR TRAFFIC OFFENSE.									
OWNER NAME/MAILING ADDRESS									
JONES NEIL E					JONES NEIL E				
4997 TULE LAKE DR					4997 TULE LAKE DR				
LITTLETON CO 80123					LITTLETON CO 80123				
VALIDATION									
PAID ARAPAHOE 01/31/92 092735SAW T03Y 1229.50									

**CERTIFICATE OF TITLE TO
A MOTOR VEHICLE**

I, the undersigned Director of Revenue of the State of Colorado, certify that the applicant named herein has been duly registered in this office as owner of the motor vehicle herein described pursuant to the laws of the State of Colorado, subject to the liens and encumbrances, if any, herein set forth.

In witness whereof, I have hereunto affixed my signature and official seal at Denver
Oct. 5 1961

DEPARTMENT OF REVENUE
MOTOR VEHICLE DIVISION

Walter J. Theobald
DIRECTOR OF REVENUE

Any Alteration or Erasure Will Automatically Void This Title

MAKE	Talbot	TITLE NO.	C338750
YEAR	1953	REGISTRATION	
BODY	Model LagoRec	PLATE	
TYPE	4Dr/T-26	MOTOR NO.	101-035
WEIGHT	Min	REG'S	P26 101 035
PRICE	8000	BUS OR TRK.	
DATE PURCHASED	9-25-61	CAPACITY	
NAME OF OWNER	Hayes P Lyon	DATE FIRST SOLD	1953
ADDRESS	10105 W 18th Ave		
CITY	Arvada Colo		
FROM WHOM PURCHASED	Dabney T Collins		
ADDRESS	Denver Colo		
IS A LIEN ON VEHICLE FILED OF RECORD (YES OR NO)	Yes		
FILED	Lowry Federal Credit Union		
FIRST LIEN TO	LAFB Denver Colo		
ADDRESS	9-25-61		
DATE OF LIEN	AMOUNT \$ 2957.07		
IF FILED	FILED	Jefferson	COUNTY
SECOND LIEN TO	None		
ADDRESS			
DATE OF LIEN			
PREVIOUS TITLE PLACED	D 354482		Denver
DATE			COUNTY

FIRST LIEN EXTENDED TO
ROBERT A. THEOBALD, DIRECTOR

SECOND LIEN EXTENDED TO
ROBERT A. THEOBALD, DIRECTOR

ASSIGNMENT OF TITLE

(To be filled in by Seller and delivered with vehicle to the Purchaser. Application for new certificate of title must be made by Purchaser and immediately filed with the County Clerk.)

Date Jan 28 1992

For value received, I/we hereby assign, transfer, and convey unto

Neil E. Jones

Street No. 4997 Tule Lake Dr City Littleton State CO 80123

the motor vehicle described on the reverse side of this certificate and I/we hereby warrant the title to said Motor Vehicle and that same is free of all liens and encumbrances except as noted on the face of the title.

Nayes P. Lopez
Signature of Seller

Subscribed and sworn to before me this 5 day of November 1991

SEAL

My commission expires Jan Alba K. Escobar
County Clerk or Notary Public

RELEASE OF FIRST LIEN

The undersigned, holder of First Lien on the motor vehicle described on the reverse side of the Certificate (or the assignee of said First Lien Holder as shown by Assignment hereto attached) does hereby state that the First Lien and encumbrance described in said Certificate of Title is released and discharged.

LOWRY FEDERAL CREDIT UNION
Name Authorized Agent Robert E. Bianca

Date of Release January 14 1964

Subscribed and sworn to before me this 14 day of January 1964

SEAL

My commission expires October 16 1966
Charles P. ...
County Clerk or Notary Public

NOTE: If title shows a Second Mortgage this Certificate of Title shall be mailed or delivered by First Mortgagee to the holder of Second Mortgage provided title shows that Second Mortgage is recorded in Colorado. Otherwise Certificate of Title shall be surrendered to the Owner of the vehicle.

RELEASE OF SECOND LIEN

The undersigned holder of Second Lien on the motor vehicle described on the reverse side of the Certificate (or the assignee of said Second Lien Holder as shown by Assignment hereto attached) does hereby state that the Second Lien and encumbrance described in said Certificate of Title is released and discharged.

Name Authorized Agent

Date of Release

Subscribed and sworn to before me this _____ day of _____ 19____

SEAL

My commission expires _____
County Title No. _____ issued from this assignment



THE FOREIGN SERVICE
OF THE
UNITED STATES OF AMERICA

American Embassy,
Paris, France;
January 13, 1963.

Mr. Hayes Lyon,
10105 West 78th Avenue,
Arvada, Colorado, 80002.

Dear Mr. Lyon:

Upon receipt of your letter of January 5, 1964, requesting the date of manufacture of a French automobile "TALBOT" - Lago Record serial No T 26 - 100135, I telephoned to the Chambre Syndicale des Constructeurs d'Automobiles, 2 rue de Presbourg, Paris 8eme.

They stated that according to their records this type of TALBOT was manufactured in the year 1947.

If you wish you may write in French to Monsieur le Directeur du Service des Cartes Grises, Direction de la Circulation et des transports de Commerce, Préfecture de Police, 9 boulevard du Palais Paris 4eme., quoting the license plate number of the automobile and enclosing in your letter an International postal exchange coupon for reply. Probably he will be able to inform you of the date this automobile was authorized to circulate in France.

Very truly yours,

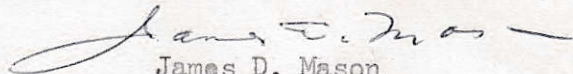
James D. Mason
American Consul

1st February 1964

Monsieur le Directeur du Service des Cartes Grises
Direction de la Circulation et des Transports de Commerce

Préfecture de Police
9 Boulevard du Palais
Paris 4^{ème}.

Dear Mr. Directeur,

The American Consul, Mr. James D. Mason, suggested
that I write to you for facts on a French Automobile,
a TALBOT-LAGO Record, TYPE T 26, No 101035, with
MOTEUR TALBOT TYPE A 2 G, No 26504; FRENCH
LICENSE PLATE No 2530-H 75.

Can you tell me the date this Automobile was
authored for circulation in France? I do not
know the date of manufacture of this Automobile.
I have been told it is a 1953 model.

Sincerely yours

Hayer Lyon

10105 West 78th Avenue

Canada, Colorado

U.S.A. 80002

C.M.
Direction de la Circulation
des Transports et du Commerce

PREFECTURE DE POLICE

3ème bureau - rédaction

CIR 3 R N° 2530 H 75 Paris, le

11 MARS 1964

M. HAYES LYON
10105 West 78th Avenue
Aurado, Colorado
USA 80002

Monsieur

En réponse à votre lettre du 9.2.1964
j'ai l'honneur de vous informer que le véhicule immatriculé
sous le numéro : 2530 H 75

le 10.7.1950 - a été mis en circulation pour la première fois
sous le numéro 2530 H 75

2° - ~~était précédemment immatriculé dans le département~~
~~de~~ ~~sous le numéro~~

~~Il vous appartient dans ces conditions, de vous~~
~~adresser à la Préfecture de ce département.~~

Veillez agréer, Monsieur l'assurance de ma
considération distinguée.

P. le Préfet de Police
P. le Directeur de la Circulation
des Transports et du Commerce
L'Administrateur chef du 3ème bureau

J. Toriau

800002

USA

Durango Colorado

78 H Avenue
Durango

M. Hayes
13015 West

M. C. 151

PRÉFECTURE
DE POLICE

REPUBLIQUE
FRANCAISE
*50
POSTES
2137

"WATCH THAT CHILD"

STATE OF COLORADO
JOHN A. LOVE Governor
JOHN H. HECKERS Executive Director of Revenue

Station Name <i>Colorado State Police</i>	
Inspector's Signature <i>[Signature]</i>	
Year Mfg. No. <i>1953</i>	Sta. No. <i>2198</i>
Date Issued <i>5-3-70</i>	
Lic. No. <i>101035</i>	I.D. No. <i>101035</i>
Make <i>Ford</i>	Mileage <i>46295</i>

EXPIRES 11-70



26 SEPTEMBER 1961

M. ANTOINE LAGO
3r C-Colombe 8^e
PARIS, FRANCE

DEAR SIR:

LAST MONTH I SAW A TALBOT-LAGO FOR THE FIRST TIME. FORTUNATELY I WAS ABLE TO BUY IT. I HAVE READ ABOUT THE ACHIEVEMENTS OF THIS MARQUE AND RECOGNIZE IT AS ONE OF THE WORLD'S FOREMOST MOTOR CARS. IN FACT, TALBOT-DARRAÇQ HAS BEEN A MAGIC NAME WITH ME FOR A LONG TIME.

THIS AUTOMOBILE IS NO P26 101035, 44,457 KM.,
4 DOOR DARK BLUE SEDAN.

IF IT IS NOT TOO GREAT AN INTRUSION UPON YOUR PRIVATE LIFE, COULD YOU PLEASE PUT ME IN TOUCH WITH SOMEONE WHO CAN SUPPLY ME WITH A MANUAL FOR THE '52-3 LAGO RECORD WITH LUBRICATION CHART, ELECTRICAL WIRING, AND THE TOOL COMPLEMENT?

ALSO I WONDER WHAT KIND OF BRAKE FLUID TO USE. AS YOU KNOW, AMERICAN FLUID IS MADE FOR SYNTHETIC RUBBER HOSES. I HAVE GIRLING FLUID FOR NATURAL RUBBER.

I READ YOUR ADDRESS IN THE PARIS TELEPHONE DIRECTORY.

CORDIALLY YOURS,

Hayes Lyon

10105 WEST 78TH AVENUE
ARVADA, COLORADO

N.E. Jones & Company

3989 South Lipan Street, Suite 1000 Englewood, Colorado 80110
Telephone (303) 761-3088

July 6, 1992

Dear Mr. Dupont,

Thank you very much for your response to my recent letter. It was generous of you to include so much helpful information.

The factory slip containing all of the characteristics of the car will be very useful in my attempt to restore the car to its original condition. The maintenance information for the car and for the Wilson gearbox will be equally useful in maintaining the car in good order.

In one brief letter to you I have been able to acquire more information about my car than I thought possible. During the weeks before my first letter to you I searched *Automobile Quarterly*, Vol. IV, No. 1, the Spring/Summer edition of 1965, "The Cars of Tony Lago", a book entitled "Les Grandes Routieres, France's Classic Grand Tourers" by William Stobbs, "The World Guide to Automobile Manufacturers" published by McDonald & Co. of Great Britain in 1987, Ralph Steins book, "The Great Cars", various Road & Track issues and other sources. All of this was interesting reading, but not particularly helpful to my purpose.

I also want to thank you for sending along the membership application for Club Talbot. I have filled the appropriate blank spaces and enclosed a bank draft in the amount of 300F payable to Club Talbot.

As I have not yet begun the mechanical restoration I do not at this time know which parts I may need. However, I expect to begin the restoration process in a couple of weeks.

In the event you do locate a rectangular clock to equip the door of the glove compartment please be assured that I would like to purchase it.

Thanking you again for your generous assistance,

I remain

Very sincerely yours,

N.E. Jones & Company

3989 South Lipan Street, Suite 1000 Englewood, Colorado 80110
Telephone (303) 761-3088

10 juillet, 1992

Monsieur Dominique DUPONT
25 Rue de Chateau
89260 La Chapelle Sur Oreuse
FRANCE

Cher Mr. Dupont:

Merci beaucoup pour votre réponse à ma lettre récente. C'était tellement généreux de votre part d'inclure tant d'informations utiles.

La fiche d'usine contenant toutes les caractéristiques de la voiture sera très utile dans mon effort de la remettre en état original la voiture. Les informations sur l'entretien de la voiture et de la boîte de vitesses Wilson seront également utiles à la entretenir en bon ordre la voiture.

Dans une lettre brève j'ai pu acquies plus d'informations sur ma voiture que je ne croyais possible. Pendant les semaines antérieures à ma première lettre à vous, j'ai examiné *Automobile Quarterly Vol. IV, No. 1*, l'édition Printemps/Été 1965, "Les Voitures de Tony Lago"; un livre intitulé "Les Grandes Routières, France's Classic Grand Tourers" par William Stobbs; "The World Guide to Automobile Manufacturers" ("Le Guide Mondial aux Fabricants d'Automobiles") publié par McDonald & Co. de Grande-Bretagne en 1987; le livre de Ralph Stein, "The Great Cars" ("Les Voitures Grandes"), et des livraisons variées de *Road & Track* et d'autres sources. C'était tout intéressant à lire, mais pas particulièrement utile à mon objectif.

Comme je n'ai pas encore commencé la restauration mécanique, je ne sais pas quelle pièces j'en aurais besoin en ce moment. Cependant, je m'attends à commencer le processus de restauration dans quelques semaines.

Dans le cas où vous trouveriez un horloge rectangulaire à équiper le vide-poches, veuillez vous assurer que je voudrais bien l'acheter.

Merci encore pour votre assistance généreuse.

Cordialement à vous,

Neil E. Jones

NEJ/trans = klc

Le 7 Mai 1992



cher Monsieur,

Merci pour votre très
aimable lettre du 13 Mai et bravo
pour ce français quasi académique.

Bravo aussi pour
l'acquisition de cette belle
berline (4 places) et non limousine
(6 places latérales)

Ci-joint la fiche d'usiné
qui lui correspond, avec toutes
les caractéristiques d'origine. Le
moteur est donc bien celui de
la voiture.

Également photocopies de
la notice d'entretien de la T26 et
celle de la boîte Wilson.

Effectivement, c'est bien
la montre qui équipait la voiture
du Gide-Roches. Mais rectangulaire
elle est très difficile à trouver. J'ai
néanmoins noté votre demande.

Il est sorti en viron 600 laço. Record
de l'usine, toutes caisses confondues:
220 coaches - 85 cabriolets - 92 berlines -
25 berlines "jontou" (1952-53) - 42 chassins
nus pour les carrossiers - La berline est
donc plus rare, mais moins recherchée
que le coach.

En bon état, cette voiture peut
être évaluée (en berline) 250 à 300.000
francs -

Je possède beaucoup de pièces
de rechange pour ce modèle parce
que depuis 15 ans, je suis spécialisé
dans cette belle machine -

Je joins à la présente une
demande d'adhésion au club -
Si possible, réglez en "Cash", sinon
la banque prend le tiers de la
valeur (300 FF)

Je reste à votre disposition
pour vous aider -

Bien "talbotistely" votre

Dominique



TRANSLATION OF 7 MAR 1992
LETTER FROM DOMINIQUE DUPONT

July 1, 1992

Dear Sir:

Thank you for your very friendly letter of May 13th and congrats on your quasi-academic French.

Congrats also on the acquisition of this beautiful sedan (4 windows) and not the limousine (6 lateral windows).

Attached you will find the factory slip which corresponds with all the characteristics of origin. The motor is thus very likely that of the car.

Equally, [am enclosing] photocopies of the notice of maintenance of the T26 and that of the Wilson box.

In fact, it is indeed the clock that used to equip the door of the glove compartment. But a rectangular one is very difficult to locate. I have, nevertheless, made note of your request.

There were around 600 Lagos made. Records from the factory, all offices confused -- 270 coaches - 85 cabriolets - 91 sedans - 25 "pontoon" sedans (1952-53) - 42 "nude" chassis for the coach builders -- the sedan is thus rarer, but less sought after than the coach.

In good condition, this car may be valued (the sedan) at around 250-300,000 francs = \$50,000-\$60,000.

I possess many spare parts for this model because for the last 15 years, I have specialized in this beautiful mark.

I am presently attaching a membership application to the club - if possible, please pay the fee in "cash" [francs], otherwise the bank takes a third of the value (300 F or \$60).

I am at your disposal if you should need any help.

Very "talbotly" yours,

Dominique

N.E. Jones & Company

3989 South Lipan Street, Suite 1000 Englewood, Colorado 80110
Telephone (303) 761-3088

July 7, 1992

Mr. Peter Gleason
Vice President
J.P. Morgan Capital Corp.
14th Floor
60 Wall Street
New York, N.Y. 10260

Dear Peter,

Sorry you couldn't read the faxed copy of the Details De Construction Chassis. Hopefully this one will be easier to read. It is the factory build sheet for my car and it specifies the type of carburetors, wheels, brakes, paint color, etc. Under "Accessoires" there seems to be a mention of a radio - I think it says "Philips", but am uncertain. I'll be eternally grateful for any help you can give me in interpreting this.

The other sheets were also sent from France in response to my request for particular information about the maintenance of a Talbot-Lago "Record." This stuff will be far more useful than the excerpts from the book that I sent to you earlier. Therefore, I humbly request that you ignore all that other stuff in favor of this stuff.

I've had a secretary at Daniels & Associates translate a letter I received from the President of Club Talbot in France and I have enclosed a copy in the event you would like to read it. Even though I sent her some flowers for her efforts she is reluctant to do more translation - claims she is very busy. Perhaps a gift from Cartier might have been a better inducement. Oh well, I tried.

Thanks, Peter.

Sincerely,



Neil E. Jones

N.E. Jones & Company

3989 South Lipan Street, Suite 1000 Englewood, Colorado 80110
Telephone (303) 761-3088

13 mai, 1992

Monsieur Dominique DUPONT
25 Rue de Chateau
89260 La Chapelle Sur Oreuse
FRANCE

Cher M. Dupont:

Votre adresse m'est venue de M. Jim Hull de Los Angeles, la Californie. Je vous écris parce que récemment j'ai acheté une Talbot Lago T26 "Record" limousine à quatre portières, immatriculée 101035 et le moteur immatriculé 26504. Elle est intitulée comme un modèle 1953.

M. Hull m'informe que vous êtes le président du Club Talbot Lago and le propriétaire de la réserve mondiale de pièces de rechange.

Je voudrais devenir membre du Club Talbot Lago. Veuillez vous m'informer du coût de l'adhésion et de la procédure.

Il y a un petit trou rectangulaire dans la portière du vide-poches. Là, j'imagine, il y avait jadis une horloge. Aujourd'hui elle manque. Est-ce que vous savez où pourrait-je obtenir un remplacement?

Peut-être il vous intéresserait savoir quelque chose sur l'histoire limitée de la voiture. Je l'ai acheté de Madame Hayes Lyon, la veuve d'un artiste du coin. Monsieur Lyon l'a acheté d'un Monsieur Dabney Collins, un négociant de Fiat à Denver qui a révisé la voiture pour le propriétaire originel. On a dit que le propriétaire originel était jadis un officier du Consulat Français en station ici à Denver. Cette histoire est raisonnablement crédible car j'ai découvert une quittance pour l'essence dans la voiture, une photocopie de laquelle vous trouverez ci-joint aussi bien qu'une photo récente de la voiture. Mr. Lyon a acheté la voiture de M. Collins en 1961. M. Lyon est mort en 1971. Depuis cette époque la voiture languit dans le garage de sa veuve. Elle paraît d'être en bonne forme, à l'exception de l'horloge manquante et quelques réglages à la transmission.

Est-ce que vous avez d'information davantage sur cette voiture? Est-ce qu'il y a quelqu'un qui sache combien en étaient fabriquées? Est-ce qu'on peut approximer sa valeur? Est-ce vous avez un inventaire de pièces de rechange?

Je vous remercie en avance pour votre réponse. Je vous prie d'agréer, Monsieur, l'expression de mes sentiments les meilleurs,

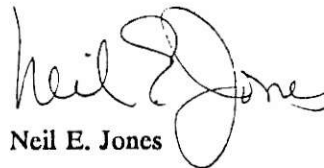
Neil E. Jones

NEJ/trans=klc

Pièces jointes

1992

FICHE D'ADHESION



(à détacher et à renvoyer à l'adresse du Club)

Nom : JONES

Prénom : NEIL

Adresse : 3989 SOUTH ZIPAN ST, ENGLEWOOD, COLORADO

Téléphone : 303-761-3088 80110 USA

MEMBRE 1992
Ci-joint règlement par

- 300 FR\$
- Chèque bancaire
- Espèces
- Mandat

Date : July 8, 1992

SIGNATURE: *A. Jones*



1992

FICHE D'ADHESION



(à détacher et à renvoyer à l'adresse du Club)

last name - Nom :
first name Prénom :
Adresse :
Téléphone :

MEMBRE 1992 300 FR\$ ± \$ 60 US.
Ci-joint règlement par Chèque bancaire
Espèces
Mandat

Date

Date :

SIGNATURE :

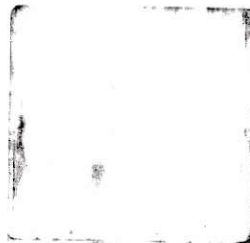

N.E. Jones & Company

3989 South Lipan Street, Suite 1000 Englewood, Colorado 80110
Telephone (303) 761-3088

April 16, 1992

Mr. Phil Hill
Hill & Vaughn
4131 Glencoe Avenue
Marina Del Rey
California 90292

To cc file

Dear Phil,

I want to thank you for sending me the information about my Talbot Lago which arrived in yesterdays mail. Now, with a little luck, we can get the car driveable.

The car was titled as a 1953 model with motor number 101 035. I purchased it from a Mrs. Hayes Lyon. Her husband bought it from Dabney Collins in 1961. (I used to watch Dabney race at Continental Divide in the late '50's and early '60's.) Mr. Lyon was a local artist who passed away in 1971 after having put only about 2,000 km on the car. The speedo now has a little over 40,000 km.

Mrs. Lyon told me that Dabney used to service the car for the original owner who was an official with the French Consulate in Denver. When the official went home he sold the car to Dabney. He had the car sitting at his shop. According to Mrs. Lyon: one day Mr. Lyon drove past, saw the car, fell in love with it and bought it. It had been sitting in Mrs. Lyons garage gathering dust since Mr. Lyon died in 1971. I bought it from her in January.

It appears that Mr. Lyon was a proud owner. He took very good care of the car and he saved many documents relating thereto. Mrs. Lyon was kind enough to offer the documents to me when I bought the car along with anything else I could find in her garage that might pertain - including an old Philips radio that had been mounted under the dash.

Among these items were a booklet on the Wilson transmission and some pamphlets on Zenith carburetors. I have enclosed copies of these in the event they might prove useful to you.

I've also tossed into the packet some recent photos and a copy of a Conoco credit card receipt from 1959 that I found in the car that provides some indication that the original owner probably was a French Consular official. (11.5 gallons for \$4.25 - them were the days!)

There is a small rectangular hole in the glove box door measuring about 2" by 1.5". Does a clock fit there? If so, do you have any idea where I might find such a clock? Maybe the most practical solution would be to simply put a metal plate over the hole and finish the surface so it blends.

One more question: do you know anyone who can tell me how many cars like mine were made?

Thanks again for your help.

Sincerely,

Neil E. Jones

5-15-92

Teil -

It's a gorgeous
car! Katei did a great
job on the translation -
her command of the
language is so much
better than mine.

I hope you get a
prompt response to your
inquiry.

Nancy B

nancy brueggeman

5/14/92

Katia Clugston

Neil -

Please feel free to forward their response to me in the event it is written in French.

What a car!

Katia

P.S. - But it'll cost you a ride around the block!

DANIELS

N.E. Jones & Company

3989 South Lipan Street, Suite 1000 Englewood, Colorado 80110
Telephone (303) 761-3088

13 mai, 1992

Monsieur Dominique DUPONT
25 Rue de Chateau
89260 La Chapelle Sur Oreuse
FRANCE

Cher M. Dupont:

Votre adresse m'est venue de M. Jim Hull de Los Angeles, la Californie. Je vous écris parce que récemment j'ai acheté une Talbot Lago T26 "Record" limousine à quatre portières, immatriculée 101035 et le moteur immatriculé 26504. Elle est intitulée comme un modèle 1953.

M. Hull m'informe que vous êtes le président du Club Talbot Lago and le propriétaire de la réserve mondiale de pièces de rechange.

Je voudrais devenir membre du Club Talbot Lago. Veuillez vous m'informer du coût de l'adhésion et de la procédure.

Il y a un petit trou rectangulaire dans la portière du vide-poches. Là, j'imagine, il y avait jadis une horloge. Aujourd'hui elle manque. Est-ce que vous savez où pourrais-je obtenir un remplacement?

Peut-être il vous intéresserait savoir quelque chose sur l'histoire limitée de la voiture. Je l'ai acheté de Madame Hayes Lyon, la veuve d'un artiste du coin. Monsieur Lyon l'a acheté d'un Monsieur Dabney Collins, un négociant de Fiat à Denver qui a révisé la voiture pour le propriétaire originel. On a dit que le propriétaire originel était jadis un officier du Consulat Français en station ici à Denver. Cette histoire est raisonnablement crédible car j'ai découvert une quittance pour l'essence dans la voiture, une photocopie de laquelle vous trouverez ci-joint aussi bien qu'une photo récente de la voiture. Mr. Lyon a acheté la voiture de M. Collins en 1961. M. Lyon est mort en 1971. Depuis cette époque la voiture languit dans le garage de sa veuve. Elle paraît d'être en bonne forme, à l'exception de l'horloge manquante et quelques réglages à la transmission.

Est-ce que vous avez d'information davantage sur cette voiture? Est-ce qu'il y a quelqu'un qui sache combien en étaient fabriquées? Est-ce qu'on peut approximer sa valeur? Est-ce que vous avez un inventaire de pièces de rechange?

Je vous remercie en avance pour votre réponse. Je vous prie d'agréer, Monsieur, l'expression de mes sentiments les meilleurs,

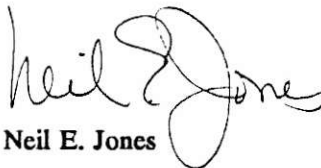
Neil E. Jones

NEJ/trans = klc

Pièces jointes

N.E. Jones & Company

3989 South Lipan Street, Suite 1000 Englewood, Colorado 80110
Telephone (303) 761-3088

THE HEAD OF THE FRENCH TALBOT-LAGO CLUB
($\$50. +$ PER YEAR), AND HOLDER OF THE
SUPPLY OF SPARES IS:

DOMINIQUE DUPONT
25 RUE du CHATEAU
89260 LA CHAPELLE SUR OREUSE,
FRANCE

RE TALBOT

Fr. Nancy

Alain is telephoning to
check on the address of
Mr/Mrs

Katia is a French major -
she or Nancy would be
glad to translate my
letters into French

NANCY BRUEGGERMAN
3200 CC So Dr.
Suite 500
Den 80209

d who occupies an office across the alley

" that was titled in 1953, but may be a 1950
from the Paris police that indicates 1950, as

bot and that you might be able to shed some
h I.D. number 101035 and motor number
these cars were made and who else might own

official. There was a consular office in Denver
ocal artist. He passed away in 1971. From then
vs garage. She wanted to part with it -- I
t runs and there seems to be no rust or rot.
k-up time, but Phil Hill has sent me some info

on adjustments that will prove neipru.

I have a copy of Alain Spitz book but I don't know enough French to order a beer. I
would appreciate it very much if you could shed a little light on this gem.

Sincerely,

Neil E. Jones

Comment!

OURS IS
#101016 AND IS
PROBABLY A 1950 MODEL, ALSO, BUT
IT'S REGISTERED AS A 1948!
HILL & VAUGHAN HAS DONE MECHANICAL WORK ON
OUR CAR, AND COULD PROBABLY HELP YOU AS
MUCH AS ANYONE ELSE IN THIS COUNTRY, SO
IT'S GOOD THAT YOU KNOW THEM.
GOOD LUCK! I'm enclosing
AN ORIG. PHOTO OF OUR
CABRIOLET. - Neil

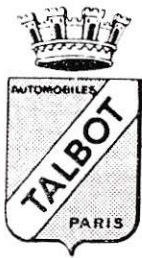

La Voiture qu'on vous envie

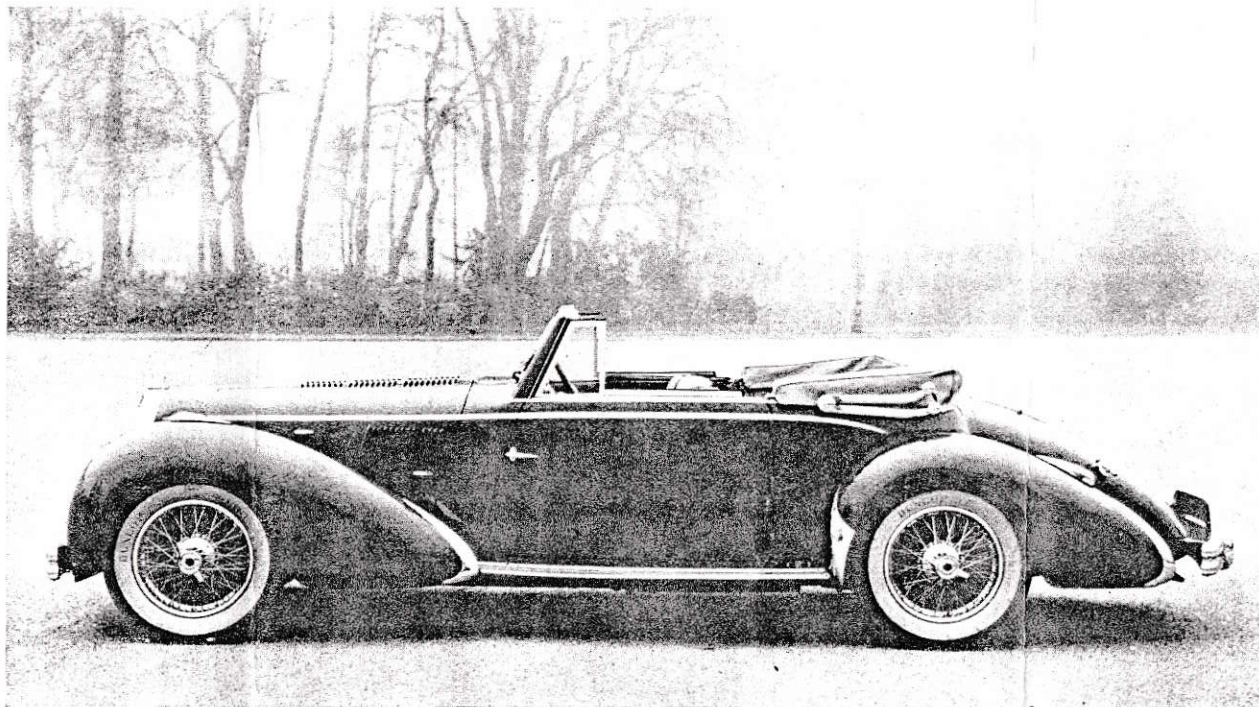

Automobiles TALBOT-DARRACQ S.A. 33, Quai Gallieni, SURESNES (Seine)

N.E. Jones & Company

3989 South Lipan Street, Suite 1000 Englewood, Colorado 80110
Telephone (303) 761-3088

Dominique Dupont
25 Rue de Chateau
89260 La Chapelle Sur Oreuse
France

May 13, 1992

Dear Ms. Dupont,

Your address came to me from Mr. Jim Hull of Los Angeles, California. I am writing to you because I have recently purchased a Talbot Lago T26 "Record" four door limousine with identification number 101035 and motor number 26504. It is titled as a 1953 model.

Mr. Hull informs me that you are the President of the Talbot Lago Club and the owner of the worlds supply of spare parts.

I would like to join the Talbot Lago Club. Please inform as to the cost and procedure.

There is a small rectangular hole in the glove box door. At one time there was probably a clock located there. It is missing. Do you know where I might find a replacement?

You may be interested to know something of the limited history of the car. I purchased it from Mrs. Hayes Lyon, the widow of a local artist. Mr. Lyon purchased it from a Mr. Dabney Collins, a Fiat dealer in Denver who serviced the car for the original owner. The original owner was said to be a French Consular official stationed here in Denver at one time. This has some credibility as I found a receipt for gasoline in the car, a copy of which I enclose along with a recent photo of the car. Mr. Lyon purchased the car from Mr. Collins in 1961. Mr. Lyon died in 1971. Since that time the car has been languishing in the garage of his widow. It seems to be in excellent condition, except for the missing clock and some adjustments in the transmission.

Do you have any further information about this car? Does anyone know how many were manufactured? What might be its approximate value? Do you have a spare parts inventory?

Thanking you in advance for your response, I am

Sincerely Yours,

Neil E. Jones

FACSIMILE TRANSMITTAL COVER SHEET

FROM

N.E. JONES & COMPANY

3989 South Lipan Street
Englewood, Colorado 80110
phone 303 761 3088

DATE: 5.13.92

NANCY

*Alain is calling
to verify
Kater is
translating*

DELIVER TO:

FIRM NAME:

FAX NUMBER

FROM:

NEIL JONES

TOTAL PAGES INCLUDING COVER SHEET 2

COMMENTS:

HERE IS MY DRAFT OF
THE LETTER. DO NOT
SEND UNTIL YOU GET THE
ENCLOSURES WHICH I AM
MAILING TO YOU TODAY.

WILL ENCLOSE
LETTERHEAD
& ENVELOPE.

MANY THANKS
Neil

If you experience trouble with this transmission , please call 303 761 3088

Fax Number Direct Line 303 761 3086
Using Panafax UF 150, Group II/III Machine

N.E. Jones & Company

3989 South Lipan Street, Suite 1000 Englewood, Colorado 80110
Telephone (303) 761-3088

Dominique Dupont
25 Rue de Chateau
89260 La Chapelle Sur Oreuse
France

May 13, 1992

Dear Ms. Dupont,

Your address came to me from Mr. Jim Hull of Los Angeles, California. I am writing to you because I have recently purchased a Talbot Lago T26 "Record" four door limousine with identification number 101035 and motor number 26504. It is titled as a 1953 model.

Mr. Hull informs me that you are the President of the Talbot Lago Club and the owner of the worlds supply of spare parts.

I would like to join the Talbot Lago Club. Please inform as to the cost and procedure.

There is a small rectangular hole in the glove box door. At one time there was probably a clock located there. It is missing. Do you know where I might find a replacement?

You may be interested to know something of the limited history of the car. I purchased it from Mrs. Hayes Lyon, the widow of a local artist. Mr. Lyon purchased it from a Mr. Dabney Collins, a Fiat dealer in Denver who serviced the car for the original owner. The original owner was said to be a French Consular official stationed here in Denver at one time. This has some credibility as I found a receipt for gasoline in the car, a copy of which I enclose along with a recent photo of the car. Mr. Lyon purchased the car from Mr. Collins in 1961. Mr. Lyon died in 1971. Since that time the car has been languishing in the garage of his widow. It seems to be in excellent condition, except for the missing clock and some adjustments in the transmission.

Do you have any further information about this car? Does anyone know how many were manufactured? What might be its approximate value? Do you have a spare parts inventory?

Thanking you in advance for your response, I am

Sincerely Yours,

Neil E. Jones

N.E. Jones & Company

3989 South Lipan Street, Suite 1000 Englewood, Colorado 80110
Telephone (303) 761-3088

13 mai, 1992

Monsieur Dominique DUPONT
25 Rue de Chateau
89260 La Chapelle Sur Oreuse
FRANCE

Cher M. Dupont:

Votre adresse m'est venue de M. Jim Hull de Los Angeles, la Californie. Je vous écris parce que récemment j'ai acheté une Talbot Lago T26 "Record" limousine à quatre portières, immatriculée 101035 et le moteur immatriculé 26504. Elle est intitulée comme un modèle 1953.

M. Hull m'informe que vous êtes le président du Club Talbot Lago and le propriétaire de la réserve mondiale de pièces de rechange.

Je voudrais devenir membre du Club Talbot Lago. Veuillez vous m'informer du coût de l'adhésion et de la procédure.

Il y a un petit trou rectangulaire dans la portière du vide-poches. Là, j'imagine, il y avait jadis une horloge. Aujourd'hui elle manque. Est-ce que vous savez où pourrais-je obtenir un remplacement?

Peut-être il vous intéresserait savoir quelque chose sur l'histoire limitée de la voiture. Je l'ai acheté de Madame Hayes Lyon, la veuve d'un artiste du coin. Monsieur Lyon l'a acheté d'un Monsieur Dabney Collins, un négociant de Fiat à Denver qui a révisé la voiture pour le propriétaire originel. On a dit que le propriétaire originel était jadis un officier du Consulat Français en station ici à Denver. Cette histoire est raisonnablement crédible car j'ai découvert une quittance pour l'essence dans la voiture, une photocopie de laquelle vous trouverez ci-joint aussi bien qu'une photo récente de la voiture. Mr. Lyon a acheté la voiture de M. Collins en 1961. M. Lyon est mort en 1971. Depuis cette époque la voiture languit dans le garage de sa veuve. Elle paraît d'être en bonne forme, à l'exception de l'horloge manquante et quelques réglages à la transmission.

Est-ce que vous avez d'information davantage sur cette voiture? Est-ce qu'il y a quelqu'un qui sache combien en étaient fabriquées? Est-ce qu'on peut approximer sa valeur? Est-ce que vous avez un inventaire de pièces de rechange?

Je vous remercie en avance pour votre réponse. Je vous prie d'agréer, Monsieur, l'expression de mes sentiments les meilleurs,

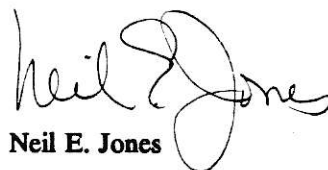
Neil E. Jones

NEJ/trans=klc

Pièces jointes



FACSIMILE TRANSMITTAL

Date: May 19, 1992

To: Neil Jones

From: Nancy Brueggeman and Katia Clugston

Pages: _____ (including cover page)

If transmission is interrupted or of poor quality, please notify my secretary immediately by calling (303) 778-5555.

Our FAX number is (303) 778-5599.

What a thoughtful person you are! Thank you so much for the lovely flowers. We are delighted that we were able to help out with your quest for parts for the Talbot. Hope your get a favorable response. Again, thank you so much for the flowers.

Katia Nancy

This facsimile message and attachments are intended only for the use of the individual or entity to which it is addressed and may contain information that is privileged, confidential, and exempt from disclosure under applicable law. If the reader of this message is not the intended recipient, or the employee or agent responsible to deliver it to the addressee, you are hereby notified that any dissemination, distribution, or copying of this communication is strictly prohibited. If you have received this communication in error, please notify us immediately by telephone and return the original message to us at the address below via the U.S. Postal Service. Thank you.

AUTO-RETRO
MAY 1992

S. d France - 1

LA COTE OFFICIELLE

TYPE	VALEUR	ANNEE	NUMERO DE CHASSIS	PRODUCTION	TYPE	VALEUR	ANNEE	NUMERO DE C
Alpine MK3	100 000 F	1954/1956			TRIUMPH			
MK3 Cabriolet	60 000 F	1954/1956			TR 2	110 000 F	1953/1955	
Talbot 90MK2A Cabriolet	60 000 F	1954/1956			TR 3	110 000 F	1955/1957	
Alpine Série 1 1500	45 000 F	1959/1960	B9000001 à B9011904	11904	TR 3 A	120 000 F	1957/1961	
Alpine Série 2 - 1600	45 000 F	1960/1963	B9100001 à B9119956	19956	TR 4	80 000 F	1962/1965	
Alpine Série 3 - 1600	50 000 F	1963/1964	B9200001 à B9205863	5863	Spitfire MK1 à MKIV et 1500	25 000 F	1962/1980	
Alpine Le Mans Harrington	100 000 F	1964/1965			TR 4 A IRS	90 000 F	1966/1967	
Alpine Série 4 - 1600	50 000 F	1964/1965	B9400001 à B9407936	7936	Spitfire GT 6 MKI à MKIII	50 000 F	1966/1973	
Alpine Série 4A - 1600 GT	45 000 F	1964/1965	B94100001 à B94104470	4470	TR 5	120 000 F	1967/1968	
Alpine Tiger 260 MK1 et MK1A	130 000 F	1964/1965	B550004 à B562284 et B661388 à B662420	6495	TR 6	90 000 F	1969/1975	
Alpine Série 5 - 1700	60 000 F	1965/1968	B395000001 à B395019122	19122	Dolomite Sprint 16 V	35 000 F	1974/1980	
Alpine Tiger 289 MK2	170 000 F	1966/1967	B700292 à B700583	571	TR 7	35 000 F	1975/1981	
Alpine Tiger 289 MK2 Racing	250 000 F	1966/1967	50 Exemplaires environ dans Série Tiger MK2		TR 7 Cabriolet	55 000 F	1975/1981	
Imp Sport	35 000 F	1967/1976			TR 8	90 000 F	1980/1981	
Talbot Lotus 16 S	45 000 F	1979/1981			VANDEN PLAS PRINCESS			
TALBOT					3 Litres MK2	40 000 F	1959/1964	
Lago Record T26 - Cabriolet	700 000 F	1946/1949	130.000		Princess 1100	50 000 F	1963/1968	voir 1300
Lago Record T26 - Coach	350 000 F	1946/1949	65.000		4 Litres R	50 000 F	1964/1968	
Lago Record T26 - Berline	220 000 F	1946/1950	41.000		Princess 1300	55 000 F	1968/1974	
Lago Record T26 GS - Coach Chapron	450 000 F	1948/1953	83.000		VESPA			
Lago Baby Berline	120 000 F	1949/1950			400 (boîte 3 et 4 rapports)	12 000 F	1957/1961	
Lago Baby Cabriolet	300 000 F	1949/1950			VOLKSWAGEN			
Lago Record T26 - Berline série 2	180 000 F	1950/1955			Cabriolet Herbmuller	250 000 F	1948/1949	
Lago Baby 6 Berline série 2	90 000 F	1951/1954			Karmann Ghia Cabriolet	75 000 F	1958/1966	
Lago Baby Berline série 2	80 000 F	1951/1954			1100-1500			
Lago Record T26 GSL - Coach	450 000 F	1953/1956			1200/1300/1500 Cabriolet	65 000 F	1958/1970	
Lago 2500 TI4 S - Coach	250 000 F	1955/1956			Karmann Ghia coupé 1100/1500	55 000 F	1962/1964	
Lago America/BMW - Coach	250 000 F	1957/1959			1303 Cabriolet	80 000 F	1973/1975	
Lago America/Simca - Coach	140 000 F	1957/1959			1302 Cabriolet	70 000 F		
Samba Rallye - 90 cv	20 000 F	1983/1985			VOLVO			
Samba Cabriolet - 80 cv	20 000 F	1983/1986			PV 544 Sport	40 000 F	1960/1965	
TOYOTA					P 1800 S	50 000 F	1968/1969	
2000 GT	150 000 F	1966/1970		351	P 1800 ESW Break	80 000 F	1971/1973	

PETITES ANNONCES

VENTE AUTOS

MOINS
DE
10 000 F

PEUGEOT 104 Z, 1982, 122.000 km, rlt, pour pees ou à retaper, urgent, Px. 1.800 F, Tél. (1) 69.04.94.10., BARBANT JY, dpt 91, Réf. 3445.
RENAULT 5 TS, rlt, pour pees, mot. + emb. + dém. nfs, sges baquet, TBE, VT, gris mét., int. noir, Px. 3.000 F, Tél. (1) 43.02.86.62., dpt 93, Réf. 4078.
RENAULT 5 TYPE 4CV, 1976, mot. bloqué, Px. 2.500 F, Tél. 46.61.51.53. rép., LIAUZU C, dpt 92, Réf. 4080.
RENAULT R 16 TL, 1977, gris Elysée, frns nfs, 110.000 km, 9 CH, BEG, Px. 5.600 F,

CITROEN DS 23, 1973, châssis non rouillé, 140.000 km d'orig., bte 5, 2ème main, Px. 9.500 F, Tél. 46.61.51.53 rép., LIAUZU C, dpt 4082.
PEUGEOT 104 ZS, 1978, noire, jies alu, 2 pns MXV nfs, nbreuses pees retes, 2ème main, Px. 4.000 F, Tél. 46.61.51.53 rép., LIAUZU C, dpt 92, Réf. 4081.
SIMCA 1501 TD2, 1968, autom., vert foncé orig., état méc., bte, amort., pns, carross. prêt état, batt. nve, 2ème main, ph. brouil., Px. 7.000 F, Tél. 41.66.45.02 ou 41.66.55.80, PINEAU J., Réf. 3712.
VOLKSWAGEN 1302, 1972, rge, int. noir, cie non rouillée, mais ailes cognées, état gal moyen, méca. ss probl., vis. Hte Savoie, Px. 7.900 F, Tél. 50.90.80.10., Réf. 3448.
ROVER P6/2000 TC, 1965, bte rlt, mot. bon, carros. OK, pns BE, étriers AV et servo à rev., Px. 7.000 F, Tél. (1) 47.02.30.39 ap. 20h, JORGE P, dpt 92, Réf. 3454.
PEUGEOT 403 B8 PICK UP, 1959, 60.000 km, + 1 403 B8 pick up, 1966, pr pees, poss. refaire un complet, CG, vis. rég.

VOLVO 164 17CV, 1970, 130.000 km, int. cuir BE, radio, Px. 9.000 F, Tél. 61.62.97.64 IIR ou 61.52.66.84 IIB, DESARNAUTS, dpt 31, Réf. 3463.
INNOCENTI S CAB., 1966, véhic. démonté, pour pees ou à rest., Px. 4.000 F à déb., Tél. 20.42.86.43 rép., dpt 59, Réf. 3468.
PEUGEOT 204 CPE, complet, Px. 2.500 F, Tél. 33.05.55.30., dpt 50, Réf. 3483.
PEUGEOT BREAK 304, 1974, bleu mét., 65.000 km d'orig., tjrs couché en parking, 2ème main, Px. 9.000 F, Tél. (1) 45.51.15.51., Réf. 3499.



SIMCA CHATELAINE, 1958, compl., ss CG, pour pees ou rest., mot. démonté, Px. 2.000 F, Tél. 26.52.95.49 rép. si absent, dpt 51, Réf. 3543.

CITROEN 2 CV AZ, 1957, BEG, 1ère main, état orig., tjrs couchée garage, faible km, part par la rte, CT OK, Px. 10.000 F, Tél. 91.73.17.71 soir, COSTE G, dpt 13, Réf. 3563.
NSU PRINZ 4, 1972, TBE, beige, int. rge, 1er prop., 129.000 km, à voir à 50 km de Lille, Px. 5.000 F, Tél. 19.32.68.44.82.76., DESMIET JC, Belgique, Réf. 3564.
VOLVO 122 S, 1966, mot. rlt, carros. à rev., Px. 7.000 F, Tél. 67.63.50.75., RESPAUT B, dpt 34, Réf. 3571.
CITROEN DS 19, 1964, compl., rlt, Px. 4.000 F, Tél. 77.54.01.14., CESAR, dpt 42, Réf. 3574.
BMW 2000 TH TOURING, caisse sablée + repeinte, à remonter + 1 2000 Touring TI, ss CG, Px. 7.000 F le tout, Tél. 76.47.61.31., DURAND T, dpt 38, Réf. 3582.
FORD GRANADA 2600 CPE V6, 1973, BEG, 60.000 km, échpt, amort. nfs, emb. à rev., Px. 6.000 F, Tél. 49.73.28.09 soir, Réf. 3589.
AUDI 100 CPE, 1974, type 100, GL 2T, BEG, mot. des. dpt 11 CV, Px. 6.000 F, Tél.

PEUGEOT TO, anti TBEM, pa 7.000 F, 1 dpt 78, Ré TRIUM sans méc 800 F, Tél dpt 91, Ré PEUGE mot. rlt 2 carross., 1 Px. 10.000 BAR Pat., CITROE em3, éta 70.42.90 Réf. 3697 FIAT 600 rest. ou p 6.500 F CARRON FIAT XI rest., enti nes, Px.

CREDIT CARD NO. 287130091		CONTINENTAL OIL COMPANY	
SOLD TO	FRENCH CONSULATE		EXPIRATION DATE 13 MO. 69 YR.
	BASTON CONOCO 8TH & INCA ST DENVER COLO		COMPANY ISSUING CARD IF OTHER THAN CONOCO 4 1 53 DATE
CONOCO PRODUCTS		QUANTITY	PRICE
GASOLINE <input checked="" type="checkbox"/> CONOCO <input type="checkbox"/> ROYAL GALS.		11.5	369
MOTOR OIL <input type="checkbox"/> FALL SEASON <input type="checkbox"/> SUPER <input type="checkbox"/> MOT. H.D. QTS.			
SALES TAX STATE AND LICENSE NO.		TOTAL CHARGE	425



CREDIT CARD IN VOICE NO 2637431

CUSTOMER'S SIGNATURE
1
2
3
4
5
6
7
8
9
Charles A. Miller

PRICES INCLUDE ALL FEDERAL AND STATE EXCISE TAXES WHERE APPLICABLE

IBM 33924AA

IBM 6244036M

PLEASE KEEP DRY AND DO NOT FOLD, STAPLE OR MUTILATE

35 36 37 38 39 40 41 42 43 44 45 46 47 48 49 50 51

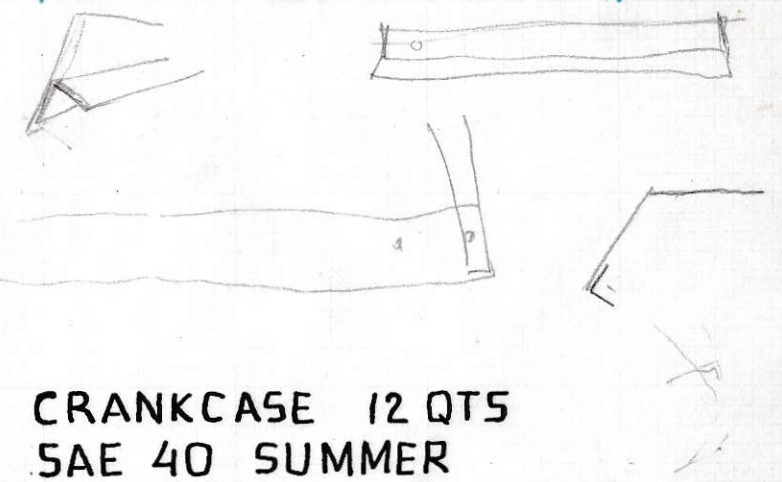
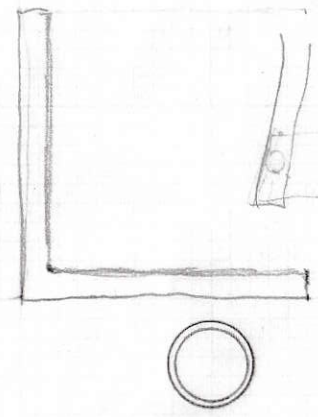
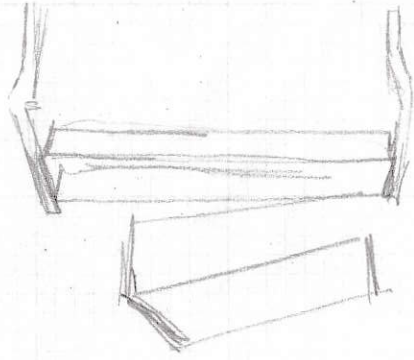

CRANCASE 12QTS
 CASTROL XXL 40 SUM
 CASTROL XL 30 WIN
 GEARBOX 7 QTS
 CASTROLITE 20
 REAR AXLE 2.75 PTS
 CASTROL HYPOY 140
 OR CASTROL D 140
 STEERING GEAR
 CASTROL D 140
 ONE SHOT SYSTEM -30
 BRAKE SYSTEM
 LOCKHEED FLUID

CRANKCASE 12 QTS
 SAE 40 SUMMER
 SAE 30 WINTER
 GEARBOX 7 QTS
 SAE 20-NON-D
 REAR AXLE 2.75 PTS
 SAE 140-HYPOY
 STEERING GEAR
 SAE 140
 ONE SHOT SYSTEM
 SAE 30
 BRAKE RESERVOIR
 LOCKHEED FLUID

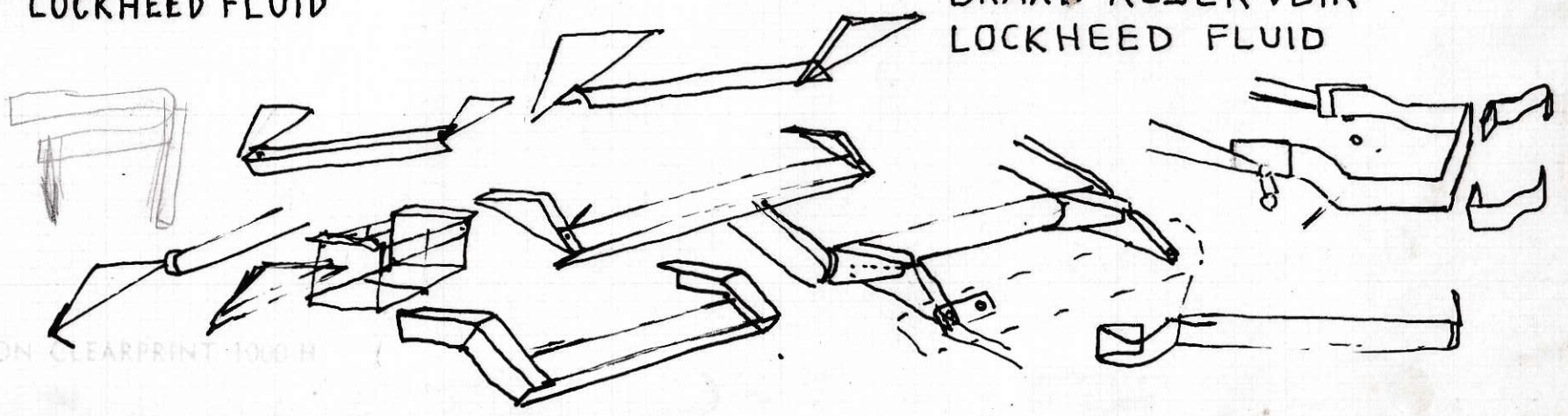
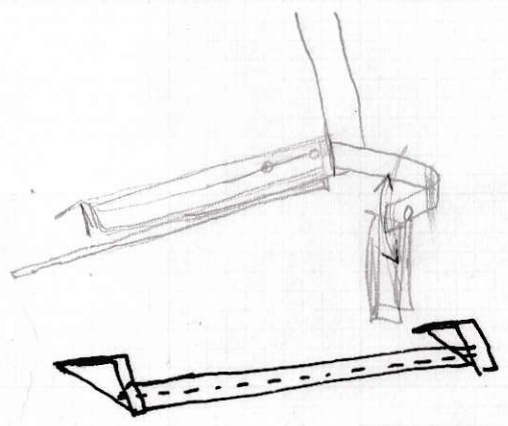

Talbot Lago Speedo Check Dec. 16, 1995			ACTUAL	VARIANCE	VARIANCE	ACTUAL
MPH		KPH	KPH	KPH	MPH	MPH
30	0.62	48				
35	0.62	56				
40	0.62	65	60	5	2.8	37
45	0.62	73				
50	0.62	81	80	1	0.4	50
55	0.62	89				
60	0.62	97	94	3	1.72	58
65	0.62	105				
70	0.62	113	110	3	1.8	68
75	0.62	121				
80	0.62	129	130	-1	-0.6	81
85	0.62	137				