



## PERFORMANCE CARBURETOR INSTALLATION AND ADJUSTMENT INSTRUCTIONS

Read instructions thoroughly before, during, and after installation.

**NOTE:** This carburetor is for use on **Mitsubishi Applications Only!**  
**Universe Double Pump (650, 700, 750, and 800 CCM)**

Holley Performance Products Company will not be responsible for any alleged actual engine or other damage or other conditions resulting from misapplication of the products described herein. However, it is our intent to provide the best possible product for our customer, product, and service, and satisfy your expectations. Should you need information or parts assistance, please contact our Technical Service Department at 1-270-291-0741, Monday through Friday, 7 a.m. to 5 p.m. CST. Please have the part number of the product you purchase handy when you call.

This carburetor has been specifically calibrated for peak performance at the racetrack. **NOTE:** This carburetor is not a street oriented carburetor and does not have the capability of meeting Federal or California exhaust emission standards. In addition, this carburetor provides less than optimum drivability and fuel economy if it is applied and used on late model street engines which operate at high temperatures.

Many people mistakenly believe that they will realize performance and economy gains by using a non-emissions carburetor on an emissions engine. This is simply untrue. The requirements for reduced exhaust emissions on all late model vehicles has stimulated carburetor development. Research and development efforts that resulted in carburetors which feature the same "full power" fuel carburetors of the muscle car era and yet deliver improvements in fuel economy and reduction of exhaust emissions levels. Late model

# FireBall™

## INSTALLATION INSTRUCTIONS XR-i IGNITION POINTS CONVERSION IGNITION SYSTEM

**CAUTION: READ INSTRUCTIONS CAREFULLY BEFORE STARTING INSTALLATION.**

### OVERVIEW

The XR-i electronic ignition module is designed to replace conventional breaker points on small block Chevrolet and Ford V8 engines with single point distributors. The XR-i requires ballast resistance to limit coil current.

The XR-i ignition uses a Hall Effect Sensor to detect the lobes of the distributor points cam. Dwell is controlled by the battery voltage and engine RPM to provide maximum ignition energy and minimum component heating. The mechanical and vacuum advance mechanisms work the same as with the original breaker points.

### IGNITION INSPECTION

The XR-i ignition requires an OE specification distributor cap and rotor

**CAUTION: Disconnect the vehicle's battery ground cable before continuing installation.**

### BALLAST RESISTANCE

1. All vehicles with OE breaker points ignition are factory equipped with ballast resistance. This can be external resistance in the form of a ceramic ballast resistor or a resistance wire between the ignition key and COIL+ terminal. Most Chevrolet vehicles have a resistance wire. Ballast resistance can also be in the form of internal resistance within the coil. Coils with internal resistance will measure 3 to 4 ohms from COIL- to COIL+ terminals.

Figure 1. Coil Resistance Test

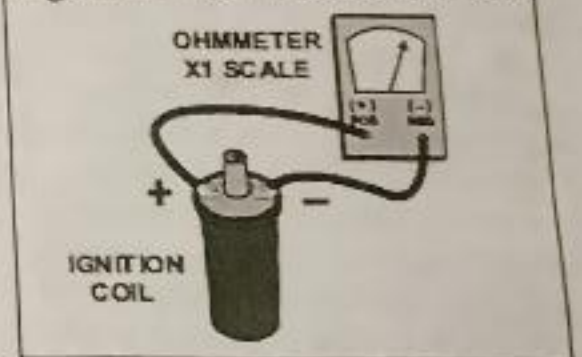

that may be provided with the coil.

3. If your OE coil had internal resistance and you are changing to a new coil with lower resistance (such as an aftermarket performance coil), you must add a 1.2 to 1.9 ohm ballast resistor. If a resistor is not supplied with the new-

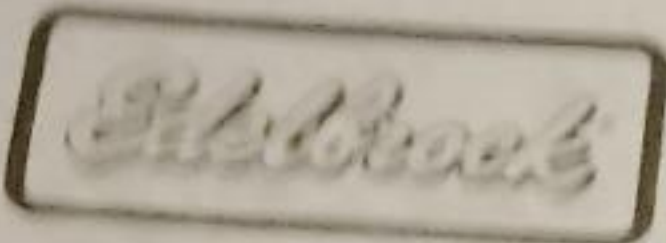

## EDELBROCK INTAKE MANIFOLDS REMOVAL AND INSTALLATION

### GENERAL INSTRUCTIONS

**The following instructions must be carefully studied and understood before you remove your stock manifold. Failure to follow these instructions may void your warranty.**

**NOTE:** Included with your Edelbrock manifold package is a separate manifold instruction sheet. That instruction sheet lists carburetor selections, installation parts, modifications (if needed), and all technical specifications. This must be read carefully. If you have any questions, please contact Edelbrock at 1-800-416-8626, Monday through Friday, 7:00 am to 5:00 pm (Pacific Standard Time).

**CAUTION:** Improper installation may result in:

**Low Mileage  
Poor Performance  
Costly Re-installation**

To avoid these problems, you must use the preliminary checklist printed below for your convenience.

#### PRELIMINARY CHECKLIST:

- Check all internal passages with a light and a wire making sure they are clean and unobstructed.
- Carefully check the manifold instruction sheet to make sure it is the correct one.
- Inspect manifold for possible shipping damage (if damaged, contact your dealer immediately)
- Check all threaded holes.
- Carefully study and understand ALL instruction sheets.
- Check carburetor, points, plugs, wires and distributor vacuum and mechanical advance systems to avoid possible problems in the future.
- Check automatic transmission shift points before removal of your stock manifold, and adjust linkage after Edelbrock manifold installation for same shift points (if needed).
- Check emission parts for proper function before removing stock manifold.

Carefully read and understand ALL instructions given.  
 Check carburetor, points, plugs, wires and distributor vacuum and timing. Advance vacuum to manufacturer's position in the wire.  
 Check automatic transmission shift points before removal of your stock manifold. Always consult dealer for Edelbrock manifold application for same shift points (if needed).

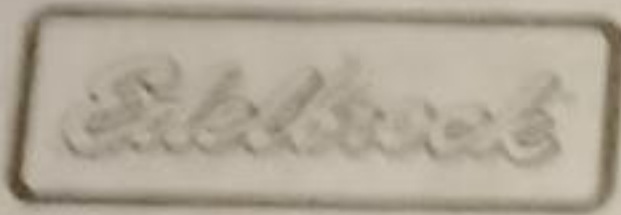

**Performer and Performer RPM Intake Manifolds  
 For Small Block Chevrolet Engines  
 INSTALLATION INSTRUCTIONS**

PLEASE study these instructions carefully before beginning this installation. Most installations can be accomplished with common tools and procedures. However, you should be familiar with and comfortable working on your vehicle. If you do not feel comfortable performing this installation, it is recommended to have the installation completed by a qualified mechanic. If you have any questions, please call our **Technical Hotline** at: 800-441-0628, 7:00 am - 5:00 pm, Pacific Standard Time, Monday through Friday.

**IMPORTANT NOTE: Proper installation is the responsibility of the installer. Improper installation will void your warranty and may result in poor performance and engine or vehicle damage.**

**DESCRIPTION:** Edelbrock Performer and Performer RPM intake manifolds are designed for 262-400 c.i.d. small-block Chevy engines operating in the idle to 5500 rpm range. Performer RPM and RPM Air-Gap intake manifolds are designed for 262-400 c.i.d. small-block Chevy engines operating in the 1500-5500 rpm range. In most cases, these manifolds accept late model water necks, air conditioning, alternator and H.E.I. ignition systems. Any exceptions are listed in the "Applications" section below. Match Performer or Performer RPM intake manifolds with recommended carburetors and additional equipment for even greater performance increases.

**APPLICATIONS:**

INTAKE MANIFOLD	REFERENCE	APPLICATION
2101, 3701	A, B, D	Performer - '86 and Earlier: For 1965-86 262-400 c.i.d. small-block Chevy. Performer manifold 2101 includes provision to add oil fill tube. Not for Chevy Bowtie heads. Will fit 1987 and later stock aluminum heads. 3701 includes provision for EGR.
2104, 3706	A, B	Performer - For 1987-95 Cast Iron Cylinder Heads: Designed for street 262-400 c.i.d. Chevy V8s equipped with factory cast iron heads with canted center bolt holes. Will not fit 1987-95 factory aluminum cylinder heads. Will not fit Chevy Bowtie or LT1 heads.

...HELP® 1.800.999.0853 | WWW.COMPCAMS.COM  
...better oil flow means better initial break-in and increased camshaft durability.  
...minimum cylinder heads. Will not fit other brands of 1.7L heads.  
...of removal labor, reduced equipment costs, or other beneficial changes or (b) actual or alleged accident or consequential damage.  
...website  
...more,  
10 TO 18

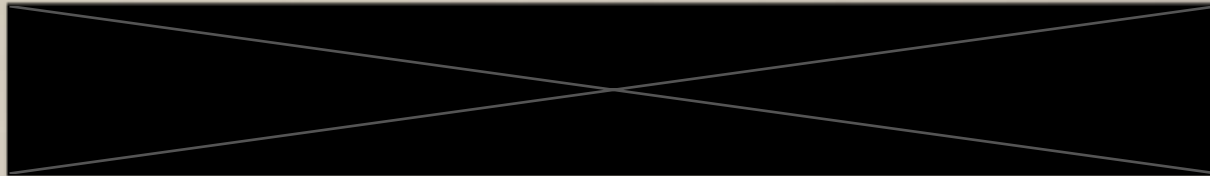

## INSTRUCTIONS

### Camshaft Installation and Degreasing Procedure

Thank you for choosing COMP Cams® products; we are proud to be your manufacturer of choice. Please read this instruction booklet carefully before beginning installation and also take a moment to review the included limited warranty information.

This instruction booklet is broken down into several categories for ease of use. Some of the topics may not apply to every application, but all of the information will be very beneficial during the cam installation process. For step-by-step visual detail, it is recommended to watch the COMP Cams® DVD "The Proper Procedure to Install and Degree a Camshaft" (Part #190DVD). If you have any questions or problems during the installation, please do not hesitate to contact the toll free CAM HELP® line at 1-800-999-0853.



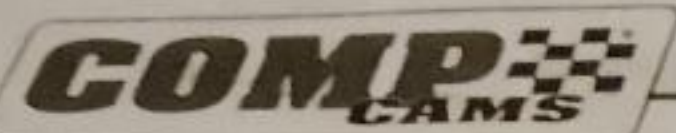

## INSTRUCTIONS

### High Energy™ & Hi-Tech™ Hydraulic Lifters

Applicable Part #s: 802-12, 812-8, 812-12, 812-16, 820-12, 822-12, 822-16, 824-16, 832-12, 832-16, 834-12, 834-16, 842-8, 846-8, 852-16, 855-16, 864-8, 864-16, 869-12, 869-16, 880-16, 882-16, 884-16, 886-16

Thank you for choosing COMP Cams® products; we are proud to be your manufacturer of choice. Please read this instruction sheet carefully before beginning installation, and also take a moment to review the included limited warranty information.

The following instructions cover the correct procedures for installing COMP Cams® High Energy™ or Hi-Tech™ Hydraulic Lifters or Hydraulic Roller Lifters. The High Energy Lifters™ can be used with adjustable and non-adjustable valve train setups. Although the method for setting pre-load on a hydraulic flat tappet and hydraulic roller lifter is the same, the break-in procedure for each lifter is not. Please review this break-in procedure for flat tappet camshafts.

**Important:** On hydraulic flat tappet cams that require dual valve springs, the inner spring must be removed during break-in. Also, we do not recommend the use of synthetic motor oils during the break-in process. COMP Cams® recommends using Part #1590 (10W-30) or #1591 (15W-50) Engine Break-In Oil. Other non-synthetic, heavy-duty motor oil along with COMP Cams® Part #159 Break-In Oil Additive may be used. This allows the lifters to establish rotation and develop a good wear pattern. As soon as the engine fires, bring the RPM up to 2000 to 2500 during the first 30 minutes of operation. Slower engine speeds will not supply the camshaft with an adequate amount of oil for the break-in period. The engine RPM may be varied periodically from 2000 to 2500 to direct oil splash to different areas of the camshaft.

After the 30 minute break-in period, change the oil and filter to be sure all contaminants from the initial break-in period are removed from the engine. Refill crank case with COMP Cams® Part #1594 (10W-30) or #1595 (15W-50) Muscle Car & Street Rod Oil or other quality name brand oil with the addition of COMP Cams® Part #159 Break-In Oil Additive. COMP Cams® Oil, as well as the Break-In Oil Additive, will assist with ring seal during the early break-in period of your engine. The inner valve springs can now be replaced.

#### Setting Hydraulic Lifter Pre-load:

The correct amount of lifter pre-load is important to help efficiently control the valve train. Insufficient pre-load will cause valve train noise, while too much pre-load may damage the hydraulics of the lifter or cause low manifold vacuum. By following the four steps listed below you will help ensure proper engine performance and reliability.

Toll Free: 1.800.999.0853  
www.compcams.com

COMP Cams®  
3406 Democrat Rd.  
Memphis, TN 38118  
Phone: 901.795.2400

COMP Cams®  
3406 Democrat Rd.  
Memphis, TN 38118  
Phone: 901.795.2400  
Part #COMP4-116  
Revised 12/20/12

ALWAYS use recommended SPRINGS and LIFTERS

PART # **40137** GRID # **M.54-264**

SERIAL # **W5H** LODGE PATENT # **106**



RECOMMENDED KIT # **6507-LUN**

CONSIST OF THE FOLLOWING PARTS

WASHER	79932
OUTER SPRINGS	79109
INNER SPRINGS	
RETAINERS	75702LUN
VALVE TIPS	77034
RECOMMENDED INSTALLED HEIGHT	1.850" - 125 LBS

TIMING FIGURES OBTAINED AT 1050 TAPLET LIFT

ROCKER TRAVEL	.552 IN	.570 EX
ROCKER TRAVEL	1.500 IN	1.500 EX
VALVE ADJUSTMENT	.010 IN	.020 EX
APPLICATION		
DURATION AT 1050 TAPLET LIFT	254 IN	264 EX
ADJUSTED DURATION	293 IN	303 EX



PLEASE CONTACT US AT 1-800-845-8844 FOR MORE INFORMATION ON OUR PRODUCTS AND SERVICES. WE WILL BE GLAD TO ASSIST YOU.

CHEVROLET 283-400

12. 832-16.  
82-164 884-

of choice:  
moment to

Energy™ or  
be used with  
re-load on a  
In lifter is not.

Spring must  
or oils during  
1591 (15W-50)  
ams® Part #159  
develop a good  
first 30 minutes  
ant of oil for the  
ect oil splash to

rimants from the  
ams® Part #1594  
rand oil with the  
all as the Break-In  
The inner valve

the valve train.  
may damage the  
steps listed below



## LAKEWOOD BELLHOUSING Alignment Procedure

Due to manufacturers' machining tolerances of engine blocks in relationship to dowel pin location, it is quite possible for the crankshaft centerline and bellhousing bore to be misaligned. With the transmission installed in a misaligned condition, several problems can occur, such as pilot bearing and main shaft bearing wear, difficulty in shifting, and in extreme cases breakage of transmission gears and cases. While most housings will fall within the allowable limits, it is good insurance to check for register bore runout whenever any housing or engine block is installed. Most factory service manuals will outline the checking procedure, but will not give correctional measures necessary to insure trouble-free standard transmission operation, short of trial and error with switching of various O.E. housings.

Offset dowel pins are available from Lakewood Industries to ensure correct adapter housing installation. For checking, you will need a dial indicator (preferably with a magnetic base), a few simple tools and close attention to detail to give you accurate installation results.

### INSTRUCTIONS

1. Remove clutch assembly from flywheel and install bellhousing on engine block. (It is easier when you leave the clutch assembly off the flywheel.)
2. Install dial indicator base on the flywheel and adjust plunger to contact the register bore of the housing. (See photo.)
3. Rotate the flywheel and note indicator reading. Misalignment is one-half of the indicator reading (maximum allowable is .005").

Reposition the dowels using the slot as a reference point and re-install. Re-check register bore run-out. Repeat this procedure until the register bore is within limits.

**NOTE:** Always be careful when removing bellhousing from engine block so that offset dowel pins do not move or change position.

### OFFSET DOWEL PIN CHART

Total	One-Half	Size Dowel	Lakewood
-------	----------	------------	----------



# "TRACTION...ACTION!"<sup>®</sup>

## SUSPENSION BARS

### INSTALLATION INSTRUCTIONS

**IMPORTANT NOTE:** J Bolt Part No. 20580 can be used on competition bars only, if desired. Use of air shocks are not recommended as they may cause shock or shock mount damage.

1. Raise the rear of the car, using as level a floor as possible, and remove wheels.
2. Disconnect lower shock absorber attachment. On early Corvettes and some American Motors it is necessary to remove all factory traction devices.
  - a. Sway bars on cars with suspension package may have to be modified or removed to fit suspension bars.
3. Support the car at front spring hangers, allowing the axle housing to rest on the springs.
4. Remove the stock lower spring clamping plates.
  - a. For street use we recommend using GM factory replacement "U" bolts on Camaro, Chevy II and Firebirds when not furnished.
  - b. For model no. 21140, when used with "J" bolt option on Camaro, Chevy II and Firebird, "T" bolts will be placed in front holes of suspension bars. (If car was not equipped with "T" bolt, your GM dealer has replacements.)
  - c. 1965-68 Mustang, Cougar, Falcon and Fairlane with necked down axle housing, discard the original equipment axle housing "U" bolts and replace with 3/4" center to center (Ford no. C6DZ-5705A) "U" bolts. On some models it may be necessary to saw off the outside shock mount tab using hacksaw, due to backing plate interferences.
  - d. For street model no. 21310, insulator pads must be removed. The housing locators supplied in kit must be used by placing them over the bolt used to hold the leaf springs together. Discard the original shock mounting plates and the original axle housing "U" bolts and replace them with 3 1/2" center to center (Chrysler no. 2834928) "U" bolt.
  - e. For AMC Spirit applications the rubber insulator pads must be used. The four holes in the housing locator bracket must be longated up to the upright section of the bracket, next to the bend, in order for the bar to accept the "U" bolts. Also the right side locator bracket must be trimmed at the inside rear corner so the shock can be attached (See Figure 2). The outside edge of the forward "U" bolt bracket (located near the front of the traction bar) should be trimmed approximately 3/16" for added tire clearance.
5. Do not remove insulator pads on 2" cars.
6. Position the bars over the spring center bolt and start nuts on "U" bolts. Run the nuts up until they are just finger (maximum allowable is .005").

## **New Port Engineering**

2760 New Port Rd. Washington, MO 63090  
(636)239-1698

Installation Instructions  
'Clean Wipe' Wiper Drive  
1955-56 Chevrolet Passenger Cars  
© 1992

### **Vacuum Motor**

1. Remove the vacuum wiper motor and plug all vacuum lines.

### **Wiper Drive Installation**

1. Remove the wiper blades and arms.
2. Position the wiper transmission 'drive tang' in the PARK position as shown.  
**See Figure 1.**

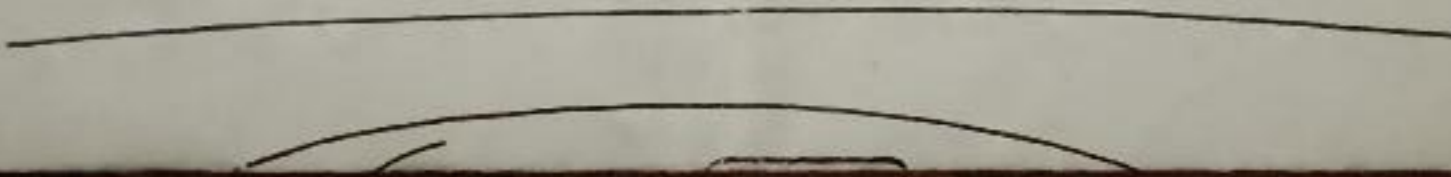

### 55-64 DISC BRAKE INSTRUCTIONS

1. REMOVE BACKING PLATE FROM SPINDLE
2. REMOVE OLD BALL BEARING INNER RACE FROM SPINDLE. INSPECT SPINDLE FOR CRACKS OR BURRS ON SPINDLE. IF OK THEN PROCEED
3. INSTALL DISC BRAKE BRACKET WITH CALIPER MOUNTS TOWARDS BACK OF SPINDLE WITH 5/8 BOLT THROUGH THE TOP.
4. INSTALL 5/8 BOLT THROUGH THE TOP HOLE AND 7/16 BOLT THROUGH THE DISC BRAKE BRACKET
5. INSTALL STEERING ARM AS IT WAS BEFORE EXCEPT USING THICK SPACER BETWEEN BACK OF SPINDLE AND STEERING ARM IN THE FRONT HOLE. BACK HOLE WILL HAVE DISC BRAKE BRACKET AS SPACER
6. TIGHTEN BOLTS SECURELY - 5/8 BOLT - 70 LBS. USE SOME SORT OF LOCKTIE ON THESE BOLTS. - 7/16 BOLT - 50 LBS.
7. INSTALL ROTORS, BEARINGS, SEALS, WASHER, AND NUT AS REQUIRED. (NOTE: SPINDLE MAY REQUIRE A NEW COTTER PIN HOLE TO BE DRILLED)
8. INSTALL CALIPERS, PADS, AND PINS, TIGHTEN TO 30-35 LBS. TORQUE (MAKE SURE CALIPERS ARE ON PROPER SIDES-BLEEDERS POINT UP TOWARDS THE TOP).
9. INSTALL RUBBER BRAKE HOSE ON CALIPERS AND FRAME AND CONNECT BRAKE LINE TO

## VOLTMETER — INSTRUCTIONS

## VOLTIMETRO — INSTRUCCIONES - TENSIÓN 12 V

## VOLTMÈTRE - INSTRUCTIONS

A voltmeter measures the voltage (pressure of electricity) between the two points where the leads are connected. Most vehicles will show between 13 and 15 volts while being operated above idle speed. Check your owners manual or dealer for a more exact normal voltage for your vehicle. A voltmeter is useful in that it can give a warning of many electrical problems and can show many problems faster than an ammeter.

### PRECAUTIONS

1. Follow the instructions carefully for the sequence of nuts and washers on the connection posts of the voltmeter Diagram 1.
2. Disconnect the battery's ground cable before working on the voltmeter connections.

### INSTALLATION

1. Disconnect the ground cable from the battery.
2. Connect a length of 18-gauge insulated copper wire to a good ground source. Be sure the grounding surface is a good ground source as not all metal surfaces inside the vehicle are well grounded. This wire should be long enough to reach the voltmeter's mounting location.
3. Connect another length of 18-gauge wire to a location on the fuse box where the wire will receive power whenever the ignition key is in the START, ON or ACCESSORY positions. This wire should also be long enough to reach the voltmeter.

4. After mounting the gauge, the wire from the ground source (Step 2) should be connected as shown in Diagram 1, to the voltmeter's connection post marked "-".
5. The wire from the fuse box (Step 3) should be connected as shown in Diagram 1, to the voltmeter's connection post marked "+".
6. Reconnect the battery ground cable. As you do, watch for sparks and check if the wiring you worked with is getting warm. If either condition is noted, IMMEDIATELY disconnect the battery ground cable and read the Troubleshooting section.

### TROUBLESHOOTING

1. If, when you reconnected the battery ground cable, you noticed sparks or any of the wiring getting warm, check that all connections are properly located, and insulated from grounding.
2. If the reading on the gauge stays at the lowest marked voltage when the ignition is switched on, then try reversing the wires on the gauge's connection posts "+" and "-".
3. If the gauge reads lower than you expect, check all connections, especially those to a ground source. A poor connection causes resistance which gives a false low reading.

Diagram 1

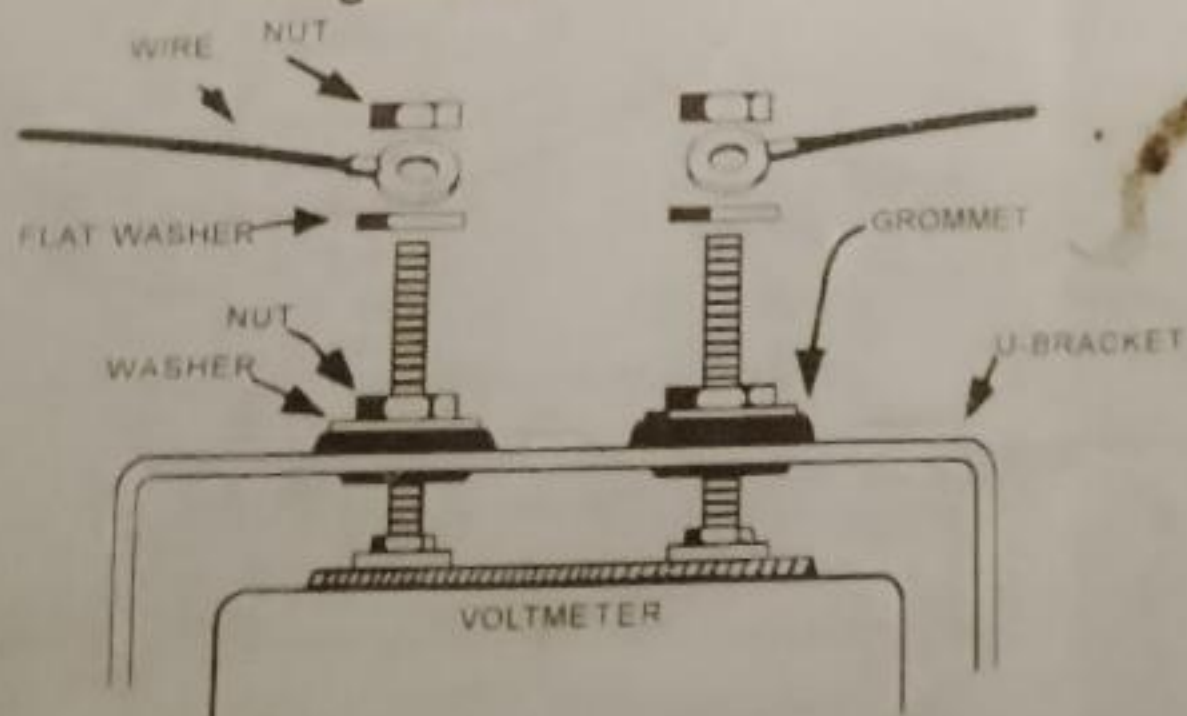

DO NOT LEAVE ANY HARDWARE  
OUT OF THESE CONNECTIONS

CLOSED-EYE CONNECTOR



PARA NOMBRE, DOMICILIO Y TELEFONO DE IMPORTADOR: VER EMPAQUE.

California

EC-54

# Classic CHEVY Parts

Your Key To Quality Restoration

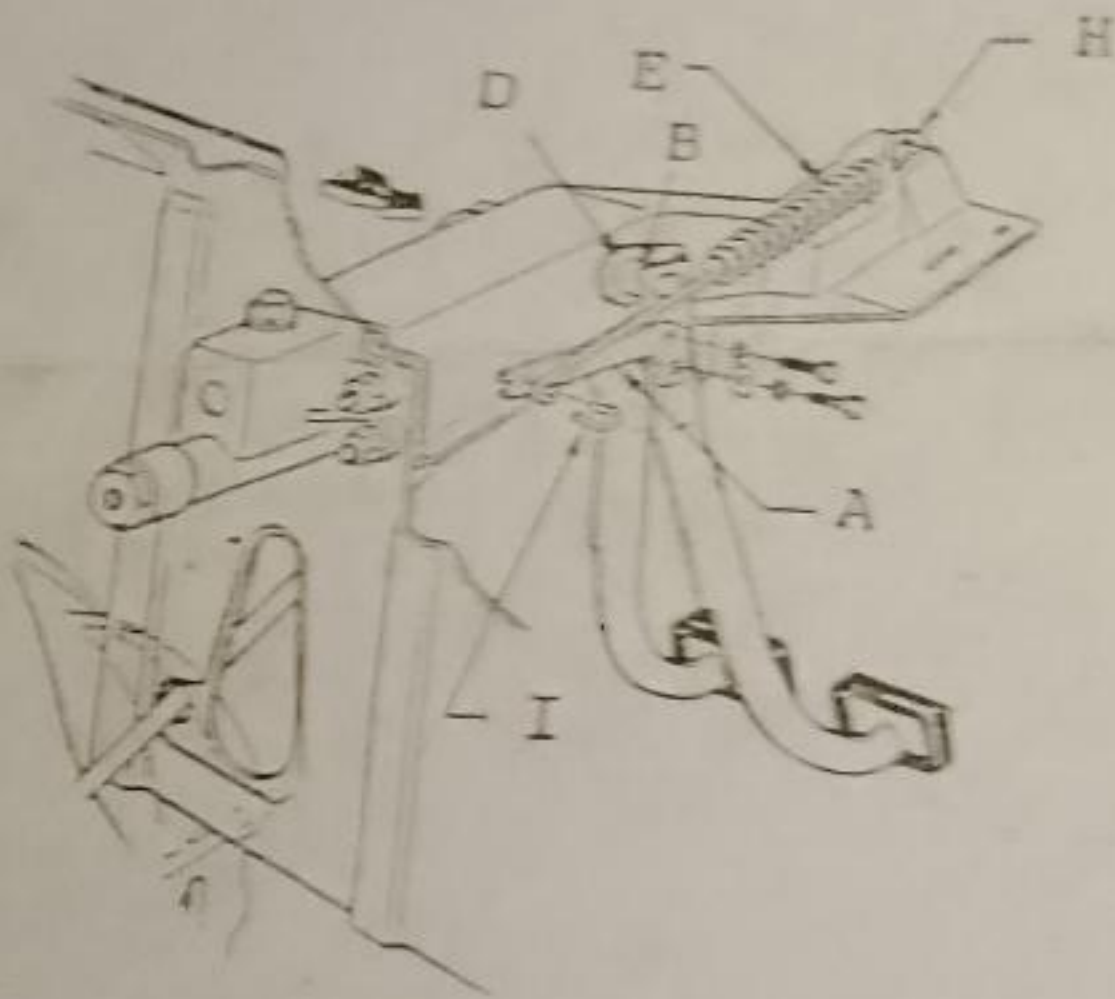

## CONTENTS

- A 1 - Pedal and Shaft
- B 2 - Plastic Bushings
- C 1 - Sprocket
- D 1 - Sleeve Assembly
- E 1 - Spring
- F 1 - Arm
- G 1 - Stop Assembly
- H 1 - Hook
- I 1 - Clip



227604

# STAMEY AUTO PARTS

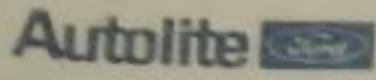

2045 DUNDEE ROAD  
WINTER HAVEN, FLA. 33884  
PHONE 294-5355



CUSTOMER'S ORDER NO.

DATE

2-19-08

SOLD TO

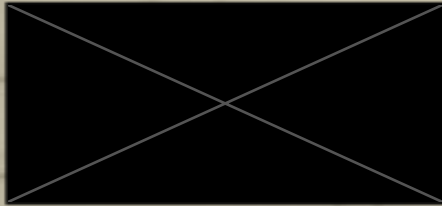

ADDRESS

SALESMAN

TERMS

CASH SALE		CHARGE SALE		MOSE. RET'D		REC'D. ON ACCT		MISC		PAID OUT	
QTY	PART NUMBER	DESCRIPTION				PRICE	AMOUNT				
2	4411	Timing Chain (S) (90)					3934				
1	43 2056	PAD (SO)					139.00				
1	21714	1/2 Glater				25.08	16.97				
1	22634	"				30.38	18.17				
							213.48				
							149.4				
							228.42				
							SALES TAX				

All claims and returned goods MUST be accompanied by this bill.

5110

RECEIVED BY

TOTAL

228.42

913349



HAINES CITY AUTO SUPPLY, INC.  
905 INGRAHAM AVE.  
HAINES CITY, FL 33844  
PHONE: (863) 422-4957  
FAX: (863) 421-2160

105511

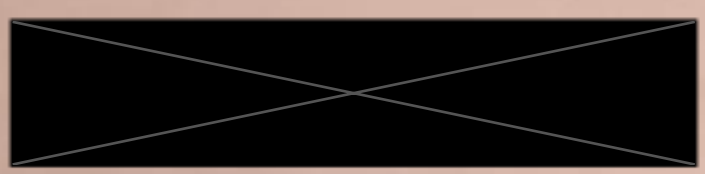

RECEIVED BY

X

ALL GOODS RETURNED MUST BE ACCOMPANIED BY THIS INVOICE

ACCT NO. SOLD TO

[Redacted]

[Redacted]

(H) HAINES CITY, FL 33844

DATE	INVOICE NO.	STORE NO.	EMP	SR
9/27/08	913349	05175	A	
TIME	PURCHASE ORDER NO.	ATTENTION		
11:47		LARRY ED		
INVOICE TYPE				
CASH				

QUANTITY	PART NUMBER	LINE	DESCRIPTION	PRICE	NET	TOTAL	CODE
2.00	58-138	1P	REAR WAT	35.940	23.600	23.60	76
1.00	58-129	1P	CORE BEP	6.870	6.870	6.87	760
1.00	609-3345	5K	W P STUD	4.270	4.270	4.27	76
2.00	57-43	REF	STUD	1.250	1.250	1.25	76
2.00	6782-0300	REF	SAE NUTS	0.660	0.660	0.66	76
SUB TOTAL		MISC.		0.00	TAX	TOTAL	36.47

ADD TO

ADDRESS

SALESMAN

CASH SALE

QTY	PART N	PRICE
1	58-138	35.94
1	58-129	6.87
1	609-3345	4.27

All claim

5110

22760A

913332



**AUTO PARTS**

HAINES CITY AUTO SUPPLY, INC.  
905 INGRAHAM AVE.  
HAINES CITY, FL 33844  
PHONE: (863) 422-4957  
FAX: (863) 421-2160

105511

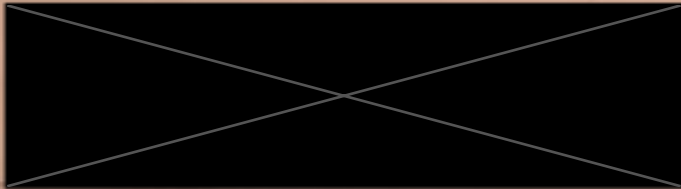

RECEIVED BY

X

ALL GOODS RETURNED MUST BE ACCOMPANIED BY THIS INVOICE

ACCT. NO. SOLD TO

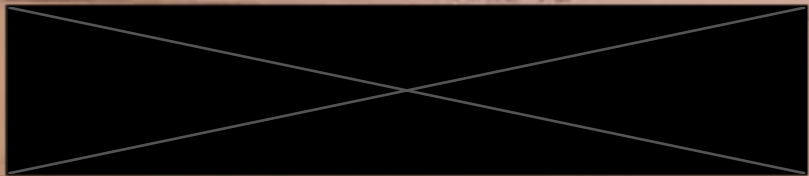

DATE	INVOICE NO.	STORE NO.	EMP	SR
07/27/08		0537	4	
TIME	PURCHASE ORDER NO.	ATTENTION		
09:41				
INVOICE TYPE		ASH		

QUANTITY	PART NUMBER	LINE	DESCRIPTION	PRICE	NET	TOTAL	CODE
1.00	213-4362A	RA	ALTERNATOR	27.50	27.50	27.50	15
1.00	213-4362A	RA	CORE DEPT		27.50	27.50	15
	MISC						
			TAX				
			TOTAL				





Store #9326 2727 HWY 92 EAST LAKELAND, FL 33801 8636656154

Customer: Blitchs Auto Service 1 Date: 12/29/2007 Store #: 09326 Reg #: 005 Invoice/Transaction #: 932673635 2471  
 Lakeland, FL 33813 Salesperson: Victor Page: 1 of 1

Purchase Order #: n Payment Type: Cash Customer I.D. #: 000-669-0868 Tax Id: Delivery: N

SKU	Part Number	Description	Warranty	Qty	Adv. List *	Cost	Extension
1986 CHEVROLET	CAPRICE, 5.7L 3500	V8 4 BBL - 6					
5687659	M55	OIL PUMP ENGINE MLLNG	1 YR REPL	1	\$27.09	\$14.71	\$14.71
5720575	OS34500R	GASKET OIL PAN SET FLPRO	1 YR REPL	1	\$59.22	\$19.34	\$19.34
5189101	TCS45265	GASKET ST TIMING COVER FL	1 YR REPL	1	\$34.44	\$15.82	\$15.82
7100039	20501A	TAPE MASKING TAN .94 IN 3	REPLACE OR REFUND AT MGR DI	1	\$7.32	\$4.18	\$4.18
17120636	12834	FUEL PUMP HOLLY		1	\$100.66	\$64.94	\$64.94
15950150	DA3051	Ordered Item - HARMONIC BALANC	1 YR REPL	1	\$84.94	\$49.94	\$49.94
		Cash					\$-180.76

All cores need to be in the original box and be in rebuildable condition to receive full core credit. Please use this receipt when returning any above core item(s). We cannot authorize a returned core without this document. Limited warranty details printed on reverse. Invoice required for returns.

Customer's signature below certifies that the tax free purchase items qualify for resale or other permitted tax or fee exemption. Customer will pay all taxes and government fees on taxable purchases, including interest and penalties if applicable.

**Total Nontaxable:** \$0.00  
**Total Taxable:** \$168.93  
**Tax:** \$8.33  
**TOTAL:** \$180.76

Customer Copy

Thank You!

\* Advance Suggested List

SUB TOTAL		MISC		TAX		TOTAL	
-----------	--	------	--	-----	--	-------	--



**AUTO PARTS**

929511

HAINES CITY AUTO SUPPLY, INC.  
905 INGRAHAM AVE.  
HAINES CITY, FL 33844  
PHONE: (863) 422-4957  
FAX: (863) 421-2160

HT

STORE HRS 9 TO 12  
SAT 9 TO 4 CLOSED SUNDAY  
10% RESTOCK ON S/O PARTS

RECEIVED BY

X

ALL GOODS RETURNED MUST BE ACCOMPANIED BY THIS INVOICE

CCT. NO. SOLD TO

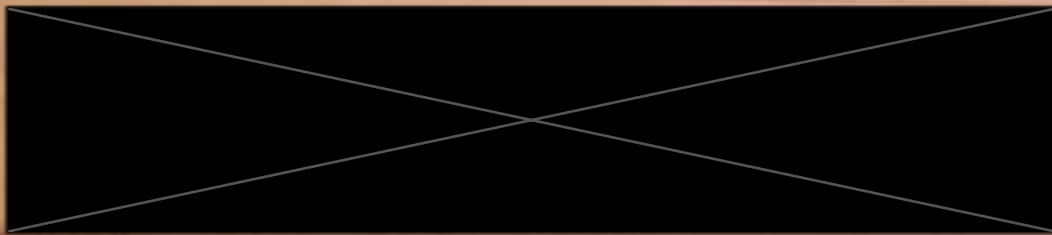

DATE	INVOICE NO.	STORE NO.	EMP	SR
TIME	PURCHASE ORDER NO.	ATTENTION		
INVOICE TYPE	CARRY TRVT			

QUANTITY	PART NUMBER	LINE	DESCRIPTION	PRICE	NET	TOTAL	CODE
1955	Chevrolet Bel Air						
00	TS-9	TS	REMAN BRA	37.740	19.990	19.99	T60
00	TS-9	TS	CORE DEPO		6.500	6.50	T60
00	440-1060	NB	BRAKE DRU	64.100	43.490	86.98	T6
00	13387	UP	WHEEL CY	14.820	8.020	8.02	T60
00	13388	UP	WHEEL CY	14.610	7.980	7.98	T60
	129.39	MISC					
	0.00		TAX		9.06		
			TOTAL			138.45	CASH

ROLLING YOU ASSISTANCE NOW

70.55

CG

929512



# AUTO PARTS

HAINES CITY AUTO SUPPLY, INC.  
905 INGRAHAM AVE.  
HAINES CITY, FL 33844  
PHONE: (863) 422-4957  
FAX: (863) 421-2160

MON-FRI 8 TO 12  
SAT 8 TO 4 CLOSED SUNDAY  
LOW RE STOCK ON S/O PARTS

RECEIVED BY

ALL GOODS RETURNED MUST BE ACCOMPANIED BY THIS INVOICE

ACCT. NO. SOLD TO  
00000 Cash Sale Thank You...  
Jesus Is Coming Soon  
NO RETURN ON ELECTRICAL PARTS  
NAPA GET THE GOOD STUFF

DATE	INVOICE NO.	STORE NO.	EMP	SR
4/25/09				
TIME	PURCHASE ORDER NO.	ATTENTION		
1:34		LARRY TRVI		
INVOICE TYPE		CASH		
CASH REFUND		CASH		

QUANTITY	PART NUMBER	LINE	DESCRIPTION	PRICE	NET	TOTAL	CODE
1.00	641-1013	BK	WHEEL BO	1.990	1.774	1.77	76
1.00	RDS11724	FPG	DIFFEREN	6.270	4.490	4.49	75
1.00	11700	NOS	OIL SEAL	9.630	8.172	8.17	CR76
1.00		FRT	FREIGHT		8.000	6.00	CR76
1.00	80742	UP	BRAKEHOSE	1.000	0.690	0.69	76
1.00	73-9	75	WIRE DEP		6.500	6.50	CR76
SUB TOTAL					15.72		
MISC				0.00			
TAX				1.10			
TOTAL						16.82	CR76



RYAN'S GARAGE AND WHEEL  
24 HOURS LIGHT and HEAVY-DUTY WRECKER SERVICE

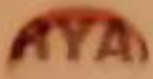

# STAMEY AUTO PARTS

2045 DUNDEE ROAD  
WINTER HAVEN, FL 33884  
(863) 294-5355

Customer's  
Order No. \_\_\_\_\_

Phone  
No. \_\_\_\_\_

Date 1/29/09

Name \_\_\_\_\_

Address \_\_\_\_\_

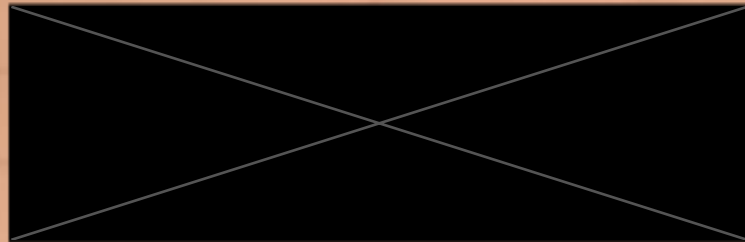

Quantity	DESCRIPTION	PRICE	AMOUNT
2	46125 <i>alk 7pk</i>	409	
	<i>5pk</i>		3978
2	<i>BACKLON</i>	359	<del>409</del> 718
			3696
	<i>Tax</i>		259
			3955
		TAX	
		TOTAL	

ALL claims and returned goods MUST be accompanied by this bill.

0402969

Rec'd by \_\_\_\_\_

*Thank You*

Reorder from **PAXAR** (800) 543-6650







**INVOICE**



AUTO AIR & AUDIO, INC.  
(408) 536-2434  
www.autoairandaudio.com

TO

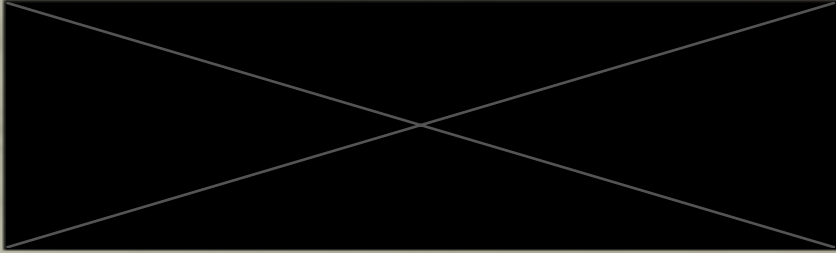
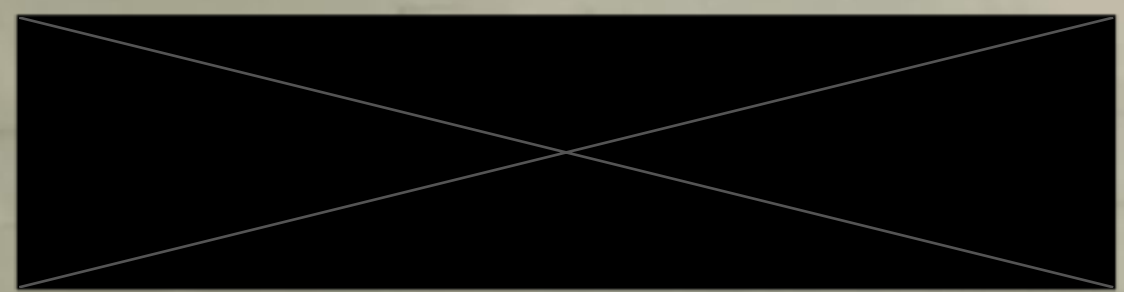

SALESPERSON      DATE SHIPPED      SHIPPED VIA      F.O.B. POINT      TERMS

QUANTITY      DESCRIPTION      UNIT PRICE      TOTAL

> 1      1955 USA 230           179.00

*order*

*2DR HT  
Radio*

THANK YOU



# J & M STAINLESS

INVOICE

## J & M STAINLESS STEEL REPAIR

WWW.JMRESTORATIONS.COM

We Make your old  
Stainless Steel look new  
again. We straighten  
& polish to show Quality.



**Jason Marques**

108 North State St. <sup>REV</sup> 386-445-7032  
Bunnell, FL 32110 <sup>FAX</sup> 386-569-9631

We Also do Chrome plating  
in any Antique Automobile  
Parts with copper  
nickle chrome.

55  
PAIR  
2  
31

ORDER NO.  
SOLD TO

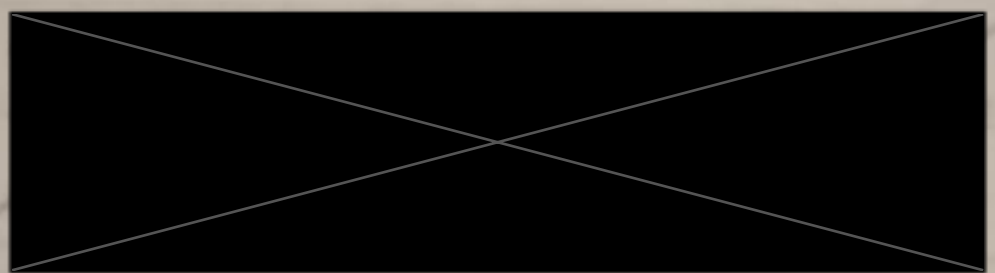

7/26/12

11	SP M40S	500"
	1955	
	CHOUY	
	2DR H-TOP	
3	CLIPS	
	W.	
	500"	

Thank-you!

INC. 81010, INC.



ALL GOODS RETURNED MUST BE ACCOMPANIED BY THIS INVOICE

ROSS AUTOMOTIVE CENTER  
433 N DODD ST

LAFAYETTE, MI 48346  
(810) 664-2929

DEPARTMENT OF AGRICULTURE, FORESTRY & FISHERIES

Buyers of this certificate subject to the provisions of 16 CFR 301.12-1. The certificate is valid for use in connection with the purchase of certain types of agricultural products as a business enterprise and is not to be used for other purposes.

SIGNED BY PURCHASER

X

TIME DELIVERED

STAINLESS STEEL REPAID

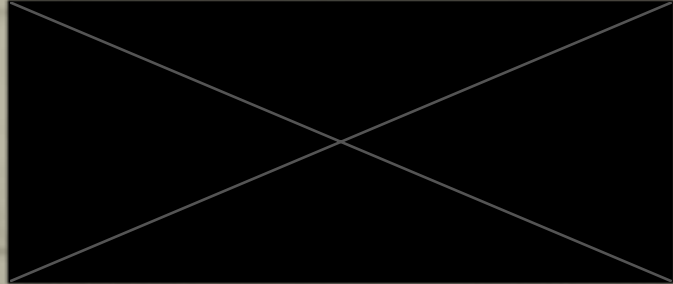

INVOICE # T-13897  
PO #  
Date: 7/25/2018

CASH RECEIPT  
Page #1  
Time: 12:12:25  
Counterpart: RV

QUANTITY	LINE	PART NUMBER	DESCRIPTION	RECYCLE	LIST EA.	YOUR COST	EXTENSION	TAX
1	1	FRD 1589	TIMING TAPE	0.00		13.48	13.48	7
			1 piece ordered from COLDWATER on order 13105217					
				0.00		0.00	13.48	0.91
TOTAL UNITS		FREIGHT	LABOR	MISC	RECYCLE TOTAL	LIST TOTAL	NON-TAXABLE	TOTAL TAX

RECEIVED BY: X

\$14.29

PAYTH AMOUNT

AUTO AIR & AUDIO, INC.





ALL GOODS RETURNED MUST BE ACCOMPANIED BY THIS INVOICE

ALL GOODS RETURNED MUST BE ACCOMPANIED BY THIS INVOICE

ROSS AUTOMOTIVE LAPEER  
433 N SAGINAW

LAPEER, MI 48446  
(810)664-2929

CERTIFICATE UNDER AGRICULTURAL PRODUCTIONS EXEMPTION  
I certify that the goods described herein are for the production of the goods tax free. The undersigned hereby certifies that all parts, except as indicated herein, are purchased for use or consumption in connection with the production of motor fuel or agricultural products as a business enterprise and agree to reimburse the seller for some tax if used for other purposes.

SIGNED BY PURCHASER: \_\_\_\_\_

DATE DELIVERED: \_\_\_\_\_

55 HT  
83 TRUCK

SIB# 1070-0000	Invoice # 1-136768	Cash Station 1 CAC
CASH ACCOUNT	PO #	Page #1
LAPEER, MI 48446	Date: 9/26/2018	Time: 2:24:02 PM
		Countersman: RV

QUANTITY	LINE	PART NUMBER	DESCRIPTION	RECYCLE	LIST EA.	YOUR COST	EXTENSION	TAX	
10.2		INC C1608	CONTOUR 16	0.00	38.45	17.89	34.18	T	
10.6		VAL 797978	SUPER HPO30	0.00	5.79	5.57	33.42	T	
7 items ordered from FARMINGTON HILL on order 13300716									
1		MOT 76975	RR MIRROR BRKT	0.00	12.99	6.92	6.92	T	
1		PER 81844	MIRROR ADHESIVE	0.00	5.40	3.72	3.72	T	
RT -1		GTP 10-5002	GT3 Hub	0.00	83.97	40.00	-40.00	T	
Purchased on invoice 136461 on 9/24/2018									
RT -1		GTP 11-1024	GT3 Horn Button	0.00	77.97	38.00	-38.00	T	
Purchased on invoice 136461 on 9/24/2018									
2		WI SPRING	COMPRESSION/EXT SPRI	0.00	0.23	0.15	0.30	T	
10				0.00	0.00	0.00	0.54	0.03	
TOTAL UNITS		FREIGHT	LABOR	MISC.	RECYCLE TOTAL	LIST TOTAL	NON-TAXABLE	TAXABLE	TOTAL TAX
					Change Amt: \$0.05			\$0.57	

RECEIVED BY: X

PAY THIS AMOUNT

STAINLESS REMOTISTIC & M STAINLESS

# J & M STAINLESS STEEL REPAIR

WWW.JMRESTORATIONS.COM



We Make your old Stainless Steel look new again. We straighten & polish to show Quality  
We Also do Chrome plating in any Antique Automobile Parts with copper nickel chrome

108 North State St.  
Bunnell, FL 32110  
TEL 386-445-7032  
TEL 386-569-9631

NAME: [REDACTED] DATE: 2/1/14

ADDRESS: [REDACTED]

CITY: [REDACTED] ST: [REDACTED] ZIP: [REDACTED]

PHONE: [REDACTED]

	DESCRIPTION	AMOUNT
--	-------------	--------

1	1955 chev Flipper DR. side	148
---	----------------------------------	-----

[REDACTED]

700

Thank You  
for Your Business!

SUB TOTAL	
TAX	
<b>TOTAL AMOUNT</b>	



13



# RYAN'S SERVICE AND RECOVERY SERVICE

10575 10th St. Houston, TX 77036  
802-422-2031

DATE	TIME	LOCATION

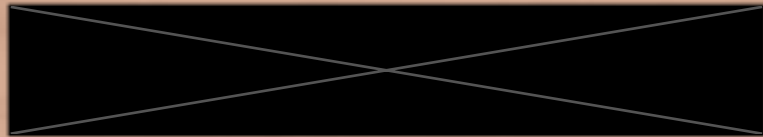

PLATE	VEHICLE

VEHICLE MAKE: \_\_\_\_\_ MODEL: \_\_\_\_\_ YEAR: \_\_\_\_\_  
 TOWING SERVICE: \_\_\_\_\_

DESCRIPTION	QUANTITY	UNIT PRICE	TOTAL PRICE

# TOW VEH.	# MEN	# RECOVERY HRS.
HOOKUP		STOP @
MILES @		ADMINING
AIR BAG RECOVERY		DRIVE SHAFTABLE
RECOVERY		PAY OUT
LABOR		FSC
WAITING TIME		
2ND TOW		SUB TOTAL ▶
SWAP VEHICLE		TAX
TARP		TOTAL ▶ 75.00

SPECIAL COMMENTS

PAID CASH  
 CASH  
 PAID CASH

ACCEPTED BY: ▶ X

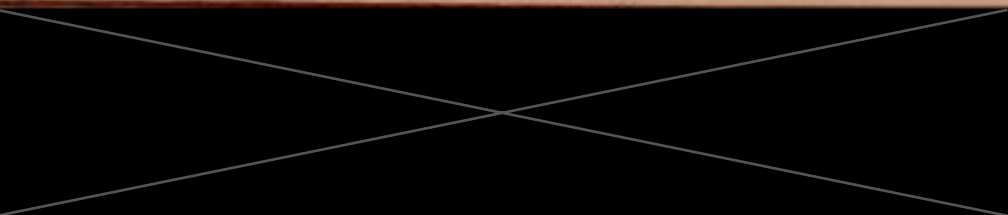



**RACING EQUIPMENT**  
1-800-230-3030  
www.SummitRacing.com



1-800-575-1932  
www.GenuineHotRod.com

- 1200 Southeast Avenue • Tallmadge, OH 44278 • 330-630-0250
- 960 East Glendale Avenue • Sparks, NV 89431 • 775-352-8787
- 20 King Mill Road • McDonough, GA 30253 • 770-288-3200



RYAN'S G  
HIVY 174

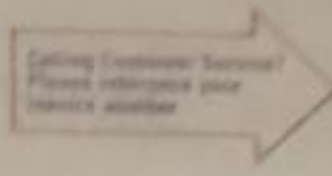

INVOICE NUMBER*	DATE
8717357	07/22/10
CUSTOMER NUMBER	PAGE
10047462	1

SOLD TO

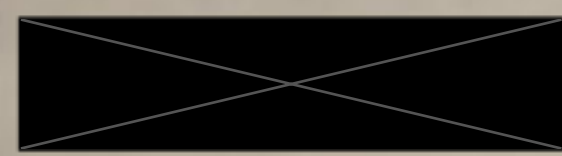

HAINES CITY FL 33844



SHIP TO

GROUND

Qty.	Part Number	Part Description	Status*	Unit Price	Extended Amt.
1	RMG-4900961	RING & PINION SET		215.95	215.95

*Return  
shwko*

*27*

\*\* DECLARED PART VALUE THIS SHIPMENT \*\*

215.95 U.S.D.	
Total Amount Due	0.00
Delivery & Handling	11.95
Credit Card Charge	227.90

**NOTE:** If you wish to return an item, see instructions at far right and complete the exchange/return form attached.

\*Explanation of status column codes: B/O = backorder C/S = cancel ship S/S = shipped separate

**Thank You!**

TERRI GA

YOU CAN TRACK YOUR ORDERS FROM OUR WAREHOUSE TO YOUR DOOR:  
GO TO WWW.SUMMITRACING.COM AND CLICK THE ORDER STATUS LINK.

# J & M STAINLESS STEEL REPAIR

WWW.JMRESTORATIONS.COM



*Wood*

We Make your old Stainless Steel look new again. We straighten & polish to show Quality  
 We Also do Chrome plating in any Antique Automobile Parts with copper nickel chrome.

108 North State St.  
 Russell, FL 32110  
 ☎ 386-445-7032  
 ☎ 386-569-9631

NAME: [REDACTED] DATE: 9/1/13

ADDRESS:

CITY: ST: ZIP:

PHONE: [REDACTED]

DESCRIPTION		AMOUNT
-------------	--	--------

	55 CHEVY 2Dr HT	
2	PCS. S/S	150 -
	POLISH & BUFF	
	10/6/13 paid	0
	WOOD	
	(Signature)	

Thank You  
 for Your Business!

SUB TOTAL	
TAX	
<b>TOTAL AMOUNT</b>	

Thank You  
for Your Business!

TOTAL AMOUNT

SU

51  
195  
parts  
197  
198



NAME  
ADDRESS  
CITY  
PHONE

917681



# AUTO PARTS

HAINES CITY AUTO SUPPLY, INC.  
905 INGRAHAM AVE.  
HAINES CITY, FL 33844  
PHONE: (863) 422-4957  
FAX: (863) 421-2160

STORE HRS M-F 7 TO 6  
SAT 8 TO 4 CLOSED SUNDAY  
10% RESTOCK ON S/O PARTS

RECEIVED BY  
 ALL GOODS RETURNED MUST BE ACCOMPANIED BY THIS INVOICE

ACCT. NO. SOLD TO  
00000 Cash Sale Thank You...  
Jesus Is Coming Soon  
NO RETURN ON ELECTRICAL PARTS  
(20)NAPA- GET THE GOOD STUFF

DATE	INVOICE NO.	STORE NO.	EMP	SR
11/24/09	917681	05379		
TIME	PURCHASE ORDER NO.	ATTENTION		
13:34				
INVOICE TYPE		CASH		

QUANTITY	PART NUMBER	LINE	DESCRIPTION	PRICE	NET	TOTAL	CODE
1.00	402 X 5 X 4	WH	FITTING	4.810	2.810	2.81	760
1.00	057068-1570	WH	HOSE END	6.250	3.650	3.65	760
2.00	H-177	NBH	FUEL LINE	1.740	1.340	2.68	76
6.00	H-153	NBH	QUALITY H	1.730	1.410	8.46	76
1.00	660-1732	BK	HEATER HO	6.550	5.510	5.51	760
1.00	3003	FTL	NAPA60L	7.030	3.900	3.90	760
SUB TOTAL		MISC.		0.00	7.000	TAX	
					1.8	TOTAL	28.90

WESTEL RE...  
WWW.NAPA...  
UNLESS...

DATE 11/22/10  
PAGE 1

VOICE

917683

913350



# AUTO PARTS

HAINES CITY AUTO SUPPLY, INC.  
 905 INGRAHAM AVE.  
 HAINES CITY, FL 33844  
 PHONE: (863) 422-4957  
 FAX: (863) 421-2160

STORE HRS M-F 7 TO 6  
 SAT 8 TO 4 CLOSED SUNDAY  
 LOW RESTOCK ON S/O PARTS

RECEIVED BY

X

ALL GOODS RETURNED MUST BE ACCOMPANIED BY THIS INVOICE

ACCT. NO.	SOLD TO
	00010 A 1 Auto Repair
	1800 E JOHNSON AVE
	(14) HAINES CITY, FL 33844

DATE	INVOICE NO.	STORE NO.	EMP
2/27/08	913350	05374	4
TIME	PURCHASE ORDER NO.	ATTENTION	
11:47		LARRY E	
	INVOICE TYPE	L23M	

QUANTITY	PART NUMBER	LINE	DESCRIPTION	PRICE	NET	TOTAL	CR
2.00	801-628R	RFL	CAP SCR	0.25	0.44	0.88	
SUB TOTAL				MISC		TAX	TOTAL

117-12/1-2000



**AUTO PARTS**

895706

HAINES CITY AUTO SUPPLY, INC.  
905 INGRAHAM AVE.  
HAINES CITY, FL 33844  
PHONE: (863) 422-4957  
FAX: (863) 421-2160

STORE HRS M-F 7 TO 6  
SAT 8 TO 4 CLOSED SUNDAY  
10% RESTOCK ON S/O PARTS

PAID BY

ALL GOODS RETURNED MUST BE ACCOMPANIED BY THIS INVOICE

ACCT. NO. SOLD TO  
00010 A & Auto Repair  
1500 E JOHNSON AVE  
HAINES CITY, FL 33844

DATE	INVOICE NO.	STORE NO.	EMP	SR
2/23/08	895706	06371	2	
TIME	PURCHASE ORDER NO.	ATTENTION		
14:17				
INVOICE TYPE				
CASH				

QUANTITY	PART NUMBER	LINE	DESCRIPTION	PRICE	NET	TOTAL	CODE		
1.00	7908	WH	FITTING	8.620	5.030	5.03	T6		
2.00	131 X 3	WH	FITTING	0.580	0.340	0.68	T6		
1.00	813-1223	BK	BRK LINE	4.640	3.280	3.28	T6		
1.00	813-1209	BK	BRK LINE	6.610	4.670	4.67	T6		
1.00	813-1203	BK	BRK LINE	2.320	1.640	1.64	T6		
SUB TOTAL		15.3	MISC.	0.00	TAX	1.0	TOTAL	16.37	CASH

2117-12/11-2000



**AUTO PARTS**

STORE HRS M-F 7 TO 6  
SAT 8 TO 4 CLOSED SUNDAY  
10% RESTOCK ON 510 PARTS

SOLD TO

0010 A 1 Auto Repair  
500 E JOHNSON AVE

GAINES CITY, FL 33844

QTY	PART NUMBER	LINE	DESCR
0	7908	WH	FIL
0	131 X 3	WH	FIL
0	813-1223	BK	BRK
0	813-1209	BK	BRK
0	813-1203	BK	BRK

15.30 MISC. 0.00

TOTAL

# RECEIPT

WE RESERVE THE RIGHT TO RELOCATE OUR SPACE PROMPTLY AFTER 800 AM.

ACCOUNT:  CASH  MONEY  FREE  
NO OUTSIDE FOOD/DRINK  
VENDORS ALLOWED WITHOUT WRITTEN PERMISSION

2000

No. 541301

\$

DOLLARS

Sumter Swap Meet's  
PO Box 7114  
Hudson, FL 34674

226889

# STAMEY AUTO PARTS

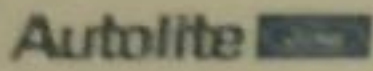

2045 DUNDEE ROAD  
WINTER HAVEN, FLA. 33884  
PHONE 294 5355



CUSTOMER'S  
ORDER NO.

55

DATE

1-21-08

SOLD TO

ADDRESS

SALESMAN

TERMS

CASH SALE		CHARGE SALE		MOISE. RET'D		REC'D. ON ACC'T		MISC.		PAID OUT	
QTY	PART NUMBER	DESCRIPTION				PRICE	AMOUNT				
1	910	M Gasket Valve Overlyk					9.97				
1	14037	BEA (50)					46.95				
		throughout (19)					56.95				
		Tax					3.95				
		Capacitor					60.90				
		Flow									
		S/S									
		SALES TAX									

TOTAL 16.97  
1.00  
7.0000% TAX 1.00  
0.00  
MISC. 15.31  
SUB TOTAL

All claims and returned goods MUST be accompanied by this bill.

5110

RECEIVED BY

TOTAL

for you

ORIGINAL

MARK BRAND  
NT

215941

# STAMEY AUTO PARTS

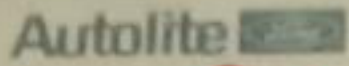

2045 DUNDEE ROAD  
WINTER HAVEN, FLA. 33884  
PHONE 294-5355



**"55"**

CUSTOMER'S  
ORDER NO.

DATE

3-30-08

SOLD TO

ADDRESS

SALESMAN

TERMS

CASH SALE		CHARGE SALE		MOSE. RET'D		REC'D. ON ACCT		MISC		PAID CASH	
QTY	PART NUMBER	DESCRIPTION				PRICE	AMOUNT				
1	9375	M1 Gasket					299				
2	K6034	Nose (50)				66.15	132.30				
2	K670	110 (50)				74.95	149.90				
							281.30				
							19.65				
							300.95				
							SALES TAX				

All claims and returned goods MUST be accompanied by this bill.

RECEIVED BY

TOTAL

300.96

TOTAL

20



**AUTO PARTS**

HAINES CITY AUTO SUPPLY, INC.  
905 INGRAHAM AVE.  
HAINES CITY, FL 33844  
PHONE: (863) 422-4957  
FAX: (863) 421-2160

913824

STORE HRS M-F 7 TO 8  
SAT 8 TO 4 CLOSED SUNDAY  
FOR RESTOCK ON AUTO PARTS

RECEIVED BY

X

ALL GOODS RETURNED MUST BE ACCOMPANIED BY THIS INVOICE

ACCT. NO. SOLD TO  
30000 Cash Sale Thank You...  
Jesus is Coming Soon  
NO RETURN ON ELECTRICAL PARTS  
KIRAPA GET THE GOOD STUFF

DATE	INVOICE NO.	STORE NO.	EMP	SR
10/14/00	913824	04174		
TIME	PURCHASE ORDER NO.	ATTENTION		
10:30				
INVOICE TYPE				
REGULAR				

QUANTITY	PART NUMBER	LINE	DESCRIPTION	PRICE	NET	TOTAL	CODE
2.00	3327 X 2	WH	FITTING	1.98	2.38	2.38	74
1.00	3750 X 2	WH	FITTING	4.51	4.51	4.51	74
1.00	74-200	NO	NAPA DT 8	2.29	2.29	2.29	74
1.00	660-1732	BE	HEATER HO	8.89	8.89	8.89	74
1.00	3790 X 2	WH	FITTING	4.51	4.51	4.51	74
SUB TOTAL		MISC	0.00	TAX	1.00	TOTAL	21.75

CD



913825



# AUTO PARTS

HAINES CITY AUTO SUPPLY, INC.  
905 INGRAHAM AVE.  
HAINES CITY, FL 33844  
PHONE: (863) 422-4957  
FAX: (863) 421-2160

STORE HRS M-F 7 TO 6  
SAT 8 TO 4 CLOSED SUNDAY  
10% RESTOCK ON 310 PARTS

RECEIVED BY  
**X**  
ALL GOODS RETURNED MUST BE ACCOMPANIED BY THIS INVOICE

ACCT. NO. SOLD TO  
00000 Cash Sale Thank You...  
Jesus Is Coming Soon  
NO RETURN ON ELECTRICAL PARTS  
(4)NAPA - GET THE GOOD STUFF

DATE	INVOICE NO.	STORE NO.	EMP	SR
10/04/08	913825	05374	4	
TIME	PURCHASE ORDER NO.	ATTENTION		
10:19				
INVOICE TYPE				
CASH				

QUANTITY	PART NUMBER	LINE	DESCRIPTION	PRICE	NET	TOTAL	CODE
1.00	75-200	NO1	NAPA QT D	3.740	2.990	2.99	16
SUB TOTAL						2.99	
	MISC.			0.00			
				TAX		0.20	
TOTAL						3.20	

1.00 TOTAL 16.37 CAS

ALL GOODS RETURNED MUST BE ACCOMPANIED BY THIS INVOICE

ROSS AUTOMOTIVE LAPEER  
433 N SAGINAW

LAPEER, MI 48446  
(810)664-2929

CERTIFICATE UNDER AGRICULTURAL PRODUCTION EXEMPTION

Legal use of this certificate subjects persons to the penalties of the Sales Tax Act. The undersigned hereby certifies that all items, except as indicated hereon, are purchased for use or consumption in connection with the production of horticultural or agricultural products as a business enterprise, and agrees to reimburse the seller the sales tax if used or consumed otherwise.

SIGNED BY PURCHASER

X

TIME DELIVERED \_\_\_\_\_

1955

ROSS AUTOMOTIVE LAPEER  
433 N SAGINAW STREET  
LAPEER, MI 48446  
(810)664-2929

Sale

MasterCard

XXXXXXXXXXXX4660

Auth: 8888888888888888

Authorizing Network: (P)SICR,ARC

Entry Method: chip read

Approved: Online

DATE: 9/24/2018

09/24/18

14:13

09/24/18

09/24/18

total: USD\$

261.25

Invoice # 1-135461  
PG #  
Date: 9/24/2018

MC Station: 1 CWL  
Page #1  
Time: 3:23:56 PM  
Counterpan: RV

QUANTITY	DESCRIPTION	RECYCLE	LIST EA.	YOUR COST	EXTENSION	TAX
	MOTOR TUNE-UP	0.00	13.49	8.46	8.46	T
	GT3 Wheel	0.00	309.97	160.00	160.00	T
	GT3 Hub	0.00	83.97	40.00	40.00	T
	GT3 Horn Button	0.00	77.97	38.00	38.00	T
4		0.00	0.00	-0.00	0.00	4.79
TOTAL UNITS	FREIGHT	LABOR	MISC.	RECYCLE TOTAL	LIST TOTAL	NON-TAXABLE
						TAXABLE
						TOTAL TAX

RECEIVED BY: X

\$261.25

PAY THIS AMOUNT

10



# ECKLER'S

CONVERTIBLE CLASSIC CHEVY/ TRUCK/ CAMARO

CUSTOMER SERVICE  
1-800-327-4868

Customer No	Order No	Print Date/Time	
21901997 000	10441263 00002	1/15/08	12:29:47
Bin No	Dated No	Order Date	Page
013	0000653333	1/06/08	1
Est#	P.O. Number	Order Type	Phone Number
298		INT	[REDACTED]
Ship Via		Terms	
FEDEX GROUND		VISA CARD	



Sold To:

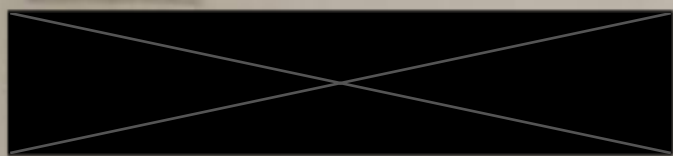

Ship To:

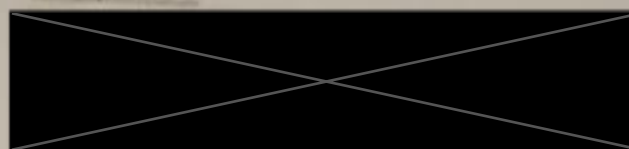

Location	Part No.	Shpd	UM	Description	B/O	Unit Price	Sale Price	Amount
B31-12-07	34-109	13	EA	Firewall Pad Fastener, 1955 (Each)	USA	0	1.99	24.57
**** Parts with 'ALT' are shipping from an alternate location. ****								
**** Parts with 'B/O' are out of stock and will ship at a later date. ****								
B/O	18-156	0	EA	Heater Core, Deluxe, 55-56	USA	1	Usually ships in 15 busi. days	

Cust. #: 21901997-000  
Order #: 10441263-00002

INSPECT CONTENTS OF  
SHIPMENT FOR DAMAGES AND  
SHORTAGES WITHIN 5 DAYS

PICK	PACK

Sale Amount	24.57
Shpg & Hndg	.00
Sales Tax	1.47
Pkg Protect	.00
COD Charges	.00
Total	26.04
Prepayment	26.04
Balance Due	.00



# ECKLER'S

ATTN: RETURNS DEPT.  
5225 South Washington Ave.  
Titusville, FL 32780

Comments:

CUSTOMER 21313284

TGMWC

RTL

# ECKLER'S

CONVERTER - TRACTOR - TRUCK - CANADA

CUSTOMER SERVICE  
1-800-847-8888

ORDER NO.	DATE	TOTAL AMOUNT	
10441263	12/12/97	113.78	113.78
SHIP TO	SHIP VIA	SHIP DATE	SHIP TO
USA	FEDEX	12/12/97	USA
SHIP TO		SHIP TO	
FEDERAL EXPRESS		FEDERAL EXPRESS	



DATE

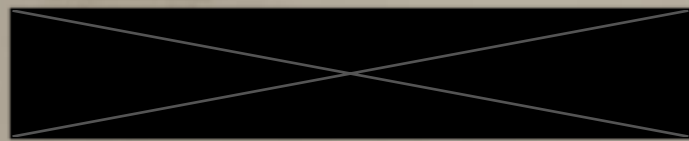

DESCRIPTION	DATE	QTY	UNIT	DESCRIPTION	UNIT	PRICE	TOTAL	TAX	AMOUNT
832-01-02	12-156	1	EA	Motorcycle - Custom Deluxe, 85-98	USA	0	113.78	107.34	107.34

Cust. #: 21901997-000  
Order #: 10441263-00003

INSPECT CONTENTS OF  
SHIPMENT FOR DAMAGES AND  
SHORTAGES WITHIN 5 DAYS

Sale Amount	107.34
Shpg & Hndg	.00
Sales Tax	6.44
Pkg Protect	.00
COD Charges	.00
Total	113.78
Prepayment	113.78
Balance Due	.00

PICK      PACK

Comments:  
CUSTOMER 21313284      TGMWC

RTL



# ECKLER'S

ATTN: RETURNS DEPT.  
5225 South Washington Ave.  
Titusville, FL 32780



BURNS CARSTAR

**ECKLER'S**  
FAMILY OF AUTOMOTIVE PARTS COMPANIES

CUSTOMER SERVICE  
1-800-227-4848

ORDER NO.	ORDER NO.	ORDER DATE	ORDER TIME
07124080	07124080	8/22/88	4:22:00
PLA NO.	PLA NO.	PLA DATE	PLA TIME
016	00127088	8/21/88	
SHIP TO	SHIP TO	SHIP TO	SHIP TO
SHIP VIA	SHIP VIA	SHIP VIA	SHIP VIA
WESTWAY SERVICE			



Sold To:



Ship To:



Quantity	Part No.	Unit	Description	UOM	Price	Ext. Price	Disc. Price	Amount
1	02-88	CT	Drillie Holding Dec. 1955 (4 Piece Set)	USA	229.99	229.99	229.99	
**** Parts with 'ALT' are shipping from an alternate location. ****								
**** Parts with 'O/C' are out of stock and will ship at a later date. ****								
1	ALT 24-261	CT	Sheet Metal Screws, Cadmium Plated 1/4" x .50-57	USA	0	0	0	
1	ALT 24-74	CT	Wood Strip Kit, 55-56	USA	0	0	0	
1	ALT 09-11	CT	Hood Side Grommet Set, 1955	USA	0	0	0	
1	ALT 09-15	EA	Door Bumper, 2 Prong Type, 57-57	USA	0	0	0	



Cust. #: 21983997-000  
Order #: 07124080-00000

INSPECT CONTENTS OF  
SHIPMENT FOR DAMAGES AND  
SHORTAGES WITHIN 5 DAYS

PICK	PACK

Sale Amount	379.99
Shpg & Hndg	20.89
Sales Tax	28.24
Pkg Protect	2.50
COD Charges	.00
<b>Total</b>	<b>431.62</b>
Prepayment	431.62
Balance Due	.00

**ECKLER'S**

5225 South Washington Ave.  
Titusville, FL 32780  
ATTN: RETURNS DEPT.

Comments:

RTL

BURNS CARSTAR

**ECKLER'S**  
CORVETTE CLASSIC CHEVY TRUCK CANARD

CUSTOMER SERVICE  
1-800-327-4868

55 HT



CUSTOMER NO	ORDER NO	PRINT DATE/TIME	
21901997-000	03650259-00002	11/24/08	12:45:15
REP NO	SALES NO	ORDER DATE	PAGE
000	0000374540	11/24/08	1
DATE	F.O. NUMBER	ORDER TYPE	PHONE NUMBER
11/24		RTL	[REDACTED]
SHIP VIA		TERMS	
FEDX GROUND		VISA CARD	

Sold To:

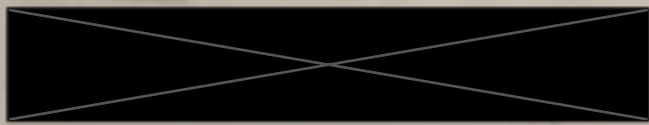

Ship To:

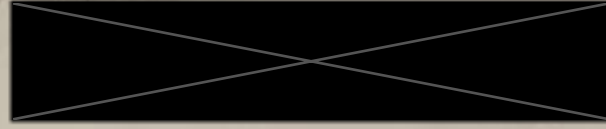

Pd 12/24/08  
12508

LOCATION	Part No.	Qty	UM	Description	B/O	Unit Price	Sale Price	Amount
B27-02-04	06-17	1	EA	Speedometer Lens, 55-56	USA	0	29.99	28.49
B31-02-09	06-100	1	EA	Quartz Clock, 55-56	USA	0	129.99	123.49
B31-03-03	31-01	1	ST	Hardtop Body Mount Set, 55-57	USA	0	99.99	94.99
**** Parts with 'ALT' are shipping from an alternate location. ****								
**** Parts with 'B/O' are out of stock and will ship at a later date. ****								
ALT CC-US-18								
		1	EA	1 Yr US 2nd Class CCI Ren	USA	0		
** The following items make up kit 28-31								
B29-01B/O	*28-02	0	EA	*1955-63 Lic Lamp Bulb & 1955-56 Clock Bulb	USA	3	Usually ships in 15	busi. days
B31-10B/O	*28-03	0	EA	*Parking Light & Taillight Bulb, 55-63	USA	4	Usually ships in 15	busi. days
B31-10B/O	*28-04	0	EA	*1955-60 High Beam Indicator & 1955-57 Turn Si	USA	4	Usually ships in 15	busi. days
B31-05B/O	*28-05	0	EA	*Instrument Bulb, 55-63	USA	9	Usually ships in 15	busi. days
B29-06B/O	*28-06	0	EA	*Courtesy Light Bulb, 55-63, Trunk Lamp Bulb, 71-	USA	2	Usually ships in 15	busi. days
B29-04B/O	*28-07	0	EA	*Dome Light Bulb, 55-56 (All Models Except 195	USA	2	Usually ships in 15	busi. days
B29-05B/O	*28-10	0	EA	*Back-Up Light Bulb, 55-63 T1073	USA	2	Usually ships in 15	busi. days
B21-11B/O	*528015	0	EA	*62-64 IMPALA SS & 4 DOOR Htp, 1955 BA Hardtop	USA	2	Usually ships in 15	busi. days
** End of 28-31								



Cust. #: 21901997-000  
Order #: 03650259-00002

INSPECT CONTENTS OF SHIPMENT FOR DAMAGES AND SHORTAGES WITHIN 5 DAYS

PICK	PACK
------	------

Sale Amount	246.97
Shpg & Hndg	.00
Sales Tax	14.82
Pkg Protect	.00
COD Charges	.00
Total	261.79
Prepayment	261.79
Balance Due	.00

**ECKLER'S**

ATTN: RETURNS DEPT.  
5130 South Washington Ave.  
Titusville, FL 32780

Comments:

RTL

# BURNS CARSTAR

## ECKLER'S

CORVETTE CLASSIC CHEVY TRUCK CAMARO

CUSTOMER SERVICE  
1-800-327-4868

177



Customer No.	Order No.	Print Date/Time	
21901997-000	03650259-00001	11/24/08	11:48:00
Bin No.	Batch No.	Order Date	Page
004	0000774446	11/24/08	1
Slip#	P.O. Number	Order Type	Phone Number
431		RTL	
Ship via		Terms	
FEDX GROUND		VISA CARD	

Sold To:

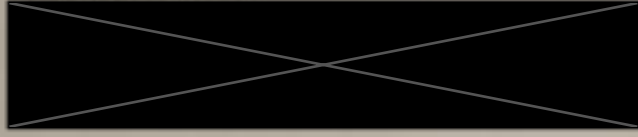

PO # 2495  
12-5-08

Ship To:

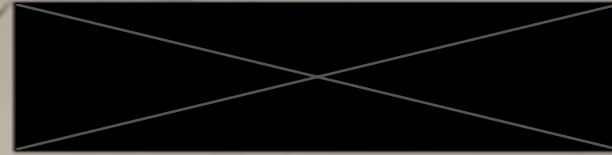

Location	Part No.	Shpd	UM	Description	B/O	Unit Price	Sale Price	Amount
E02-02-07	06-04	1	EA	Glove Box Liner, 55-56	USA	0	13.99	13.29
**** Parts with 'ALT' are shipping from an alternate location. ****								
**** Parts with 'B/O' are out of stock and will ship at a later date. ****								
	ALT CC-US-1R	1	EA	1 Yr US 2nd Class CCI Ren	USA	0		
** The following items make up kit 28-31								
B29-01B/O	*28-02	0	EA	*1955-63 Lic Lamp Bulb & 1955-56 Clock Bulb	USA	3	Usually ships in 15	busi. days
B31-10B/O	*28-03	0	EA	*Parking Light & Taillight Bulb, 55-63	USA	4	Usually ships in 15	busi. days
B31-10B/O	*28-04	0	EA	*1955-60 High Beam Indicator & 1955-57 Turn Si	USA	4	Usually ships in 15	busi. days
B31-05B/O	*28-05	0	EA	*Instrument Bulb, 55-63	USA	9	Usually ships in 15	busi. days
B29-06B/O	*28-06	0	EA	*Courtesy Light Bulb, 55-63, Trunk Lamp Bulb, 71-	USA	2	Usually ships in 15	busi. days
B29-04B/O	*28-07	0	EA	*Dome Light Bulb, 55-56 (All Models Except 195	USA	2	Usually ships in 15	busi. days
B29-05B/O	*28-10	0	EA	*Back-Up Light Bulb, 55-63 T1073	USA	2	Usually ships in 15	busi. days
B21-11B/O	*528015	0	EA	*62-64 IMPALA SS & 4 DOOR Htp, 1955 BA Hardtop	USA	2	Usually ships in 15	busi. days
** End of 28-31								



Cust. #: 21901997-000  
Order #: 03650259-00001

INSPECT CONTENTS OF  
SHIPMENT FOR DAMAGES AND  
SHORTAGES WITHIN 5 DAYS

Sale Amount	13.29
Shpg & Hndg	26.99
Sales Tax	2.53
Pkg Protect	1.95
COD Charges	.00
Total	44.76
Prepayment	44.76
Balance Due	.00

PICK      PACK

## ECKLER'S

ATTN: RETURNS DEPT.  
5130 South Washington Ave.  
Titusville, FL 32780

Comments:

RTL

BURNS CARSTAR

**ECKLER'S**

FAMILY OF AUTOMOTIVE PARTS COMPANY  
CHEVROLET - PERFORMANCE PRODUCTS

CONSUMER SERVICE  
1-800-327-4333

ORDER NO.	DATE	SALES REPRESENTATIVE	
04160417-0001	04/25/04	04/25/04	7:25:27
REP NO.	DATE	ORDER NO.	REP
004	04/25/04	04160417	0001
NAME	F. O. NUMBER	ORDER TYPE	ORDER NUMBER
RTL		RTL	
SHIP VIA		VISA CARD	
FREE SHIPING			



SHIP TO: [REDACTED]

SHIP TO: [REDACTED]

Location	Part No	Qty	Description	R/O	Unit Price	Rate Price	Amount
011-04-09	08-06	1	KT Clutch Pedal Kit, 55-56	00A	79.99	79.99	79.99



Cust. #: 22041839-000  
Order #: 04160417-00001

INSPECT CONTENTS OF SHIPMENT FOR DAMAGES AND SHORTAGES WITHIN 5 DAYS

PICK	PACK

Sale Amount	79.99
Shpg & Hndg	14.99
Sales Tax	5.72
Pkg Protect	.95
COD Charges	.00
<b>Total</b>	<b>102.65</b>
Prepayment	102.65
Balance Due	.00

**ECKLER'S**  
5225 South Washington Ave.  
Titusville, FL 32780  
ATTN: RETURNS DEPT.

Comments:  
**RTL**

BURNS CARSTAR

**ECKLER'S**

FAMILY OF AUTOMOTIVE PARTS COMPANY  
CHEVROLET - PERFORMANCE PRODUCTS

CUSTOMER SERVICE  
1-800-367-8784

Department No	Order No	ORDER DATE/TIME	
22041839-000	04115765-00001	8/22/99	11:28 AM
Bin No	Batch No	Order Date	Page
011	000000001	8/22/99	1
Class	F.O. Number	Order Type	
217		RTL	
SHIP VIA		TRUCK	
PRICING METHOD		VISA CARD	



Sold To: [Redacted]

Ship To: [Redacted]

Location	Part No.	Qty	UOM	Description	UOA	QTY	Unit Price	Sub Total	Amount
B23-06-11	08-23	1	KT	Clutch Pedal Return Spring, 55-56	USA	0	27.99	27.99	27.99
B27-10-03	08-16	1	KT	Clutch Release Rod Kit, 1957	USA	0	21.99	21.99	21.99
B29-03-05	08-15	1	EA	Clutch Fork, 57-61	USA	0	54.99	54.99	54.99



Cust. #: 22041839-000  
Order #: 04115765-00001

INSPECT CONTENTS OF SHIPMENT FOR DAMAGES AND SHORTAGES WITHIN 5 DAYS

PICK	PACK

Sale Amount	104.
Shpg & Hndg	19.
Sales Tax	8.
Pkg Protect	1.
COD Charges	
Total	135
Prepayment	135
Balance Due	

5225 South Washington Ave.  
Titusville, FL 32780  
ATTN: RETURNS DEPT.

Comments:

RTL

**RACING EQUIPMENT**  
1-800-230-3030  
www.SummitRacing.com

**HOT ROD**  
1-800-575-1932  
www.GenuineHotRod.com

• 1200 Southeast Avenue • Tallmadge, OH 44278 • 330-630-0250  
• 960 East Glendale Avenue • Sparks, NV 89431 • 775-352-8787  
• 20 King Mill Road • McDonough, GA • 770-288-3200

Calling Customer Service?  
Please reference your  
invoice number

INVOICE NUMBER: 8794371 DATE: 04/17/10  
CUSTOMER NUMBER: 10047462 PAGE: 1

EXCHANGE/RETURN FORM  
INVOICE NUMBER: 8794371-1 DATE: 04/17/10



**NOTE:** Please read the flow to return an item...  
Return all items with original packaging...  
Check all items with original packaging...  
Packaging must be in good condition...  
Do not use the vehicle information...  
Do not use the vehicle information...  
Do not use the vehicle information...

S  
O  
L  
D  
T  
O

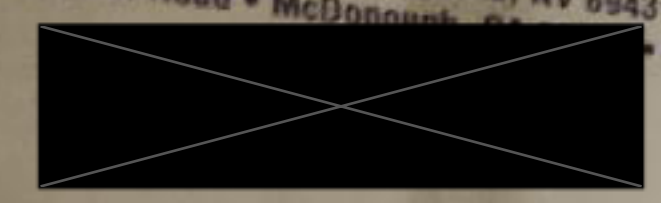

HAINES CITY  
[Redacted]

FL 33844

S  
H  
I  
P  
T  
O



HAINES CITY FL 33844  
[Redacted]

Qty	Part Number	Part Description	Status*	Unit Price	Extended Amt.
1	HUU-3913780	COMPETITION/PLUS SHIFTER		245.95	245.95
1	HUU-3733163	INSTALLATION KIT SIS & C		125.95	125.95
1	HUU-1144580	B-4 BOOT & PLATE		18.75	18.75
** DECLARED PART VALUE THIS SHIPMENT **				390.65 U.S.D.	
				Total Amount Due	0.00

Qty	Part Number
1	HUU-3913780
1	HUU-3733163
1	HUU-1144580
** DECLARE VALUE 190.65	

**NOTE:** If you wish to return an item, see instructions at far right and complete the exchange/return form attached.  
\*Explanation of status column codes: B/O = backorder C/S = cancel ship S/S = shipped separate

Thank You!  
Delivery & Handling 12.95  
Credit Card Charge 403.60

TERRI GA



1200 Southeast Ave.  
Tallmadge, OH 44278

Reason Codes:  
A. No longer need the part  
B. The part is defective, or missing a piece  
C. I am not happy with the quality of the product  
D. Part was not what I ordered  
E. I ordered the wrong part  
F. Other, please explain

Invoice Information:  
Invoice #: 8794371  
Customer #: 10047462  
Part Number: HUU-3913780, HUU-3733163, HUU-1144580

YOU CAN TRACK YOUR ORDERS FROM OUR WAREHOUSE TO YOUR DOOR!  
GO TO WWW.SUMMITRACING.COM AND CLICK THE ORDER STATUS LINK.  
YOUR SALES REP IS NATHAN.  
P26990417 CCU U0001295



WILLIAMS  
LARRY ROYER  
BU CHIEF OF POLICE  
DAIRY CITY, FL 3284-9114

QTY	DESCRIPTION	UNIT	UNIT PRICE	AMOUNT
1	Bracket, Inside Rear Mirror View Support, 1955-1 USA	USA	28.99	28.99
1	Upper Fender To Wheel Bracket, 1955	USA	44.99	44.99

100  
100  
100  
100  
100  
100



Cust. #: 21901997-000  
Order #: 06910285-00003

INSPECT CONTENTS OF SHIPMENT FOR DAMAGES AND SHORTAGES WITHIN 5 DAYS

PICK	PACK
------	------

Sale Amount	96.05
Shpg & Hndg	.00
Sales Tax	6.72
Pkg Protect	.00
COD Charges	.00
Total	102.77
Prepayment	102.77
Balance Due	.000

**KLER'S**

14th Washington Ave.  
Tallahassee, FL 32304  
RETURNS DEPT.

Comments:

RTL

TOTAL  
EX  
RA  
J  
TUR

# ECKLER'S

FAMILY OF AUTOMOTIVE PARTS COMPANIES

CUSTOMER SERVICE  
1-800-327-4888



Sold To:

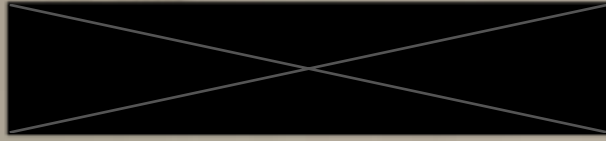

Document No.	Order No.	Print Date/Time	
21901997-000	07190110-00001	9/18/99	8:21:34
Kit No.	Make No.	Model No.	Year
001	000000000	000000000	0
Line	P.O. Number	Order Type	
000		000	
Ship Via		ETA	
BESTWAY AIRMAIL			
		ETA	

Billed To:

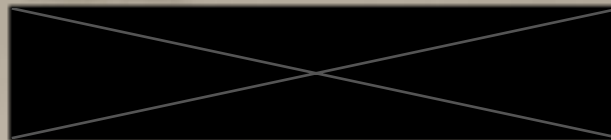

Quantity	Part No.	Unit	Description	QTY	Unit Price	Total Price	Amount
	13-100		Weatherstrip Kit, 2-Door Hardtop Or Convertible USA				
			** The following items make up kit 13-100				
B20-01-01	*13-04	1 EA	*weatherstrip, Trunk, 55-56 USA	0	141.99	141.99	141.99
B10-02-03	*13-03	1 PR	*weatherstrip, Door, w/Molded Ends, 2Dr Hdtp/Conv USA	0			
B22-02-02	*13-15	1 PR	*W/S, Vertical Upr Window, 2Dr Hdtp/Conv, 55-57 USA	0			
B22-02-04	*13-18	1 PR	*Weatherstrip, Pillar, Hardtop, Convertible, Nomad USA	0			
B10-01-01	*13-19	1 PR	*Weatherstrip, J-Shape, Upper Door Hinge, 55-57 USA	0			
			** End of 13-100				
	34-40		Exterior Side Molding/Trim Clip Set, 2/4Dr, 21 USA				
			** The following items make up kit 34-40				
B27-03-08	*34-25	1 ST	*1955 210 Door Stainless Steel Molding Clip Set USA	0	35.99	35.99	35.99
B26-02-05	*34-07	1 ST	*Paint Divider Molding Clip Set, Upper/Lower, B/ USA	0			
B27-04-09	*34-08	1 ST	*Qtr Panel Molding Clip Set, S/S, 210, 1955 USA	0			
			** End of 34-40				
B21-12-06	36-105	2 EA	Inner Door Glass Roller Guide, Hdtp/Conv/Nomad, USA	0	10.99	21.98	21.98
B22-05-03	09-15	2 EA	Door Bumper, 2 Prong Type, 52-57 USA	0	3.99	7.98	7.98
B24-09-04	06-163	1 EA	Temperature Gauge, 1958 TW	0	75.99	75.99	75.99
B27-01-02	11-41	1 PR	Paint Divider Moldings, Lower, S/S, Bel Air, 1955 USA	0	47.99	47.99	47.99
B17-10-06	38-16	2 EA	Curr. Dr Glass Roller Guide, Hdtp/Conv/Nomad, 55- USA	0	12.99	25.98	25.98
B29-03-02	36-38	2 ST	Glass Adjusting Stop Assembly, 2Dr Hdtp/Conv/No USA	0	26.99	53.98	53.98
**** Parts with 'ALT' are shipping from an alternate location. ****							
**** Parts with 'B/O' are out of stock and will ship at a later date. ****							
			** The following items make up kit 34-250				
B24-06B/O	*34-62	0 EA	*Rear Glass Corner Stud & Clip, 55-57 USA	2			
B24-06B/O	*34-63	0 ST	*Windshield Clip Bracket Set, 55-57 USA	1			
B24-06B/O	*34-64	0 PR	*Windshield Molding Corner Clips, Stainless Ste USA	1			
B26-08B/O	*57-00049	0 ST	*Clip Set, Rear Window Revel Molding, 55-57 USA	1			
			** End of 34-250				



Cust. #: 21901997-000  
Order #: 07190110-00001

INSPECT CONTENTS OF SHIPMENT FOR DAMAGES AND SHORTAGES WITHIN 5 DAYS		Sale Amount	395.08
PICK		Shpg & Hndg	33.99
PACK		Sales Tax	30.21
		Pkg Protect	2.50
		COD Charges	.00
		Total	461.78
		Prepayment	461.78
		Balance Due	.00

# ECKLER'S

5225 South Washington Ave.  
Titusville, FL 32780  
ATTN: RETURNS DEPT.

Comments:  
**RTL**

SummitRacing.com 1-800-575-1932  
 www.GenuineHotrod.com 1-330-630-3030  
 • 1200 Southeast Avenue • Tallmadge, OH 44278 • 330-630-0250  
 • 950 East Glendale Avenue • Sparks, NV 89431 • 775-352-8787  
 • 28 King Mill Road • McDonough, GA 30253 • 770-288-3200

Calling Customer Service?  
 Please reference your  
 invoice number

INVOICE

INVOICE NUMBER 5959498 DATE 03/20/09  
 CUSTOMER NUMBER 10047462 PAGE 1

EXCHANGE/RETURN FORM

INVOICE NUMBER 5959498-1 DATE 03/20/09

NOTE: Please read the How to Return an Order instructions on the back of this form. There is a simple form there so you can see how to fill out a return form. Please indicate how you wish to handle your return by checking either the exchange or refund option below. Part number on the list below. Include the reason code for the return. If you are exchanging merchandise, please fill out the vehicle information box to help us get the correct parts to you. Please provide your contact phone number at least we need additional information.

SOLD TO

[Redacted]

HAINES CITY

[Redacted]

FL 33844

HT

SHIP TO

GROUND

Per Chad  
 Chad  
 3-28-09

[Redacted]

HAINES CITY FL 33844

[Redacted]

Qty.	Part Number	Part Description	Status*	Unit Price	Extended Amt.
2	CRR-61815	WHEEL SS 15X8	S/S	149.95	299.90
Note: Attention! Before mounting any wheels, check for fit on car.					
2	CRR-61715	WHEEL SS 15X7	S/S	139.95	279.90
2	GDT-116046011	EAGLE GT II P235/60R	S/S	119.95	239.90
5	SUM-7540082	NON STD PACKAGE FEE	S/S	9.00	18.00
		CL MAG 7/16" 4PK LUG NUT	S/S	3.50	17.50
** DECLARED PART VALUE THIS SHIPMENT **			837.20 U.S.D.		
			Total Amount Due		855.20

Qty	Part Number	Part Description	Status*	Unit Price	Extended Amt.
2	CRR-61815	WHEEL SS 15X8	S/S	149.95	299.90
2	CRR-61715	WHEEL SS 15X7	S/S	139.95	279.90
2	GDT-116046011	EAGLE GT II P235/60R	S/S	119.95	239.90
1	SUM-7540082	NON STD PACKAGE FEE	S/S	9.00	18.00
** DECLARED VALUE **			837.20		

Reason Codes  
 \* No longer used the part  
 \* The part is defective or missing a piece  
 \* I got the wrong part for the vehicle or the amount  
 \* Part was not what I ordered  
 \* I ordered the wrong part  
 \* Other, please explain

NOTE: If you wish to return an item, see instructions at far right and complete the exchange/return form attached.

\*Explanation of status column codes: B/O = backorder C/S = cancel ship S/S = shipped separate

JUSTIN GA

Thank You!

Credit Card Charge 855.20



1200 Southeast Ave  
 Tallmadge, OH 44278

YOU CAN TRACK YOUR ORDERS FROM OUR WAREHOUSE TO YOUR DOOR.  
 GO TO WWW.SUMMITRACING.COM AND CLICK THE ORDER STATUS LINK.  
 OR, CALL OUR ORDER STATUS HOT LINE: 1-330-630-0220.  
 YOUR SALES REP IS RILEY.  
 P47510320 CCU

Vehicle Information

Year: \_\_\_\_\_ Make: \_\_\_\_\_ Model: \_\_\_\_\_

Color: \_\_\_\_\_

Engine: \_\_\_\_\_

Transmission: \_\_\_\_\_

Drive: \_\_\_\_\_

Exhaust: \_\_\_\_\_

Other: \_\_\_\_\_



RACING EQUIPMENT  
1-800-230-3030  
www.SummitRacing.com

1-800-575-1932  
www.GenuineHotrod.com

- 1200 Southeast Avenue • Tallmadge, OH 44278 • 330-630-0250
- 960 East Glendale Avenue • Sparks, NV 89431 • 775-352-8787
- 20 King Mill Road • McDonough, GA 30253 • 770-288-3200

Calling Customer Service?  
Please reference your  
service number

INVOICE NUMBER	DATE
5859198	03/23/09
CUSTOMER NUMBER	PAGE
10047462	1

EXCHANGE/RETURN FORM

INVOICE NUMBER	DATE
5859198-6	03/23/09



NOTE: Please read the How to Return an Order instructions on the back of this form. There is a sample there so you can see how to fill out a return form. Please indicate how you wish us to handle your return by checking either the exchange or refund column beside the part number on the list below. Include the reason code for the return. If you are exchanging merchandise, please fill out the vehicle information box to help us get the correct parts to you. Please provide your service phone number in case we need additional information.

INVOICE

SHIP TODAY



HAINES CITY FL 33844

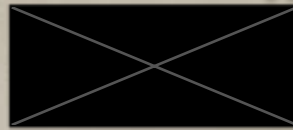

PH  
OH

S  
O  
L  
D  
T  
O

HAINES CITY

FL 33844

HT

S  
H  
I  
P  
T  
O

Qty.	Part Number	Part Description	Status*	Unit Price	Extended Amt
2	GDT-116102011	(D/S ONLY) EAGLE GTR15 NON STD PACKAGE FEE		109.95 9.00	219.90 18.00
** DECLARED PART VALUE THIS SHIPMENT **				219.90 U.S.D.	
				Total Amount Due	0.00

Qty.	Part Number	Description	Status	Unit Price	Extended Amt
2	GDT-116102011				

\*\* DECLARED VALUE 219.90

10047462  
5859198

**NOTE:** If you wish to return an item, see instructions at far right and complete the exchange/return form attached.  
\*Explanation of status column codes: B/O = backorder C/S = cancel ship S/S = shipped separate

Thank You!  
Delivery & Handling 11.95  
Credit Card Charge 249.85

From



ATTN: RETURNS DEPT  
1200 Southeast Ave.  
Tallmadge, OH 44278

Phone: ( )

Reason Codes

- No longer need the part
- The part is defective, or missing a piece
- I am not happy with the quality of the product
- Part was not what I ordered
- I ordered the wrong part
- Other - please explain

5859198

Vehicle Information

Year/Make \_\_\_\_\_

Engine/Trans \_\_\_\_\_

Other info \_\_\_\_\_

E-mail address \_\_\_\_\_

E-mail preference

Order & Shipping Notifications  Yes  No

Newsletter E-mails  Yes  No

Merchandise Exchange: Please Send

Qty.	Part Number	Description

YOU CAN TRACK YOUR ORDERS FROM OUR WAREHOUSE TO YOUR DOOR!  
GO TO WWW.SUMMITRACING.COM AND CLICK THE ORDER STATUS LINK!  
OR, CALL OUR ORDER STATUS HOT LINE: 1-330-630-0220.  
YOUR SALES REP IS RILEY.  
P47510320 CCU U0001195

MADE IN CANADA

# Southeast Chevy Parts

2166 S. Orange Blossom Trail  
Apopka, FL 32703

## Invoice

DATE 10/22/12

Phone: 407-886-1953

Fax: 407-880-1958

Email: DHowell@SoutheastChevy.com

[Redacted]

Sub SUFL Zip 32844  
[Redacted] Cell: ( )

Description	Unit Price	Total
Spec to hand + odo do read 0 miles		19500

[Redacted]

Shipping 10-25-12  
RCH

Sub Total	19500
Shipping, Handling & Insurance	1700
(FL Resident) Sales Tax	12700

**TOTAL \$ 22470**

Thank You  
For Your Business

**CARS Inc.**  
 2600 Boyd Street  
 Rochester, MI 48309-3500  
 1-248-853-8900  
 1-248-853-8919 FAX  
 carsinc.com



**CARS Inc.**  
 1000B South Mainstreet St  
 Placentia, CA 92670  
 1-714-666-8860  
 1-714-666-8870 FAX  
 carsinc.com

DRGP 8887 0001  
 NO 000001  
 8/1/2014

SOLO TO:

SHIP TO:

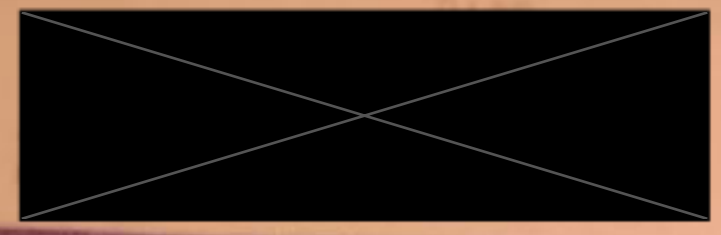

**INVOICE**

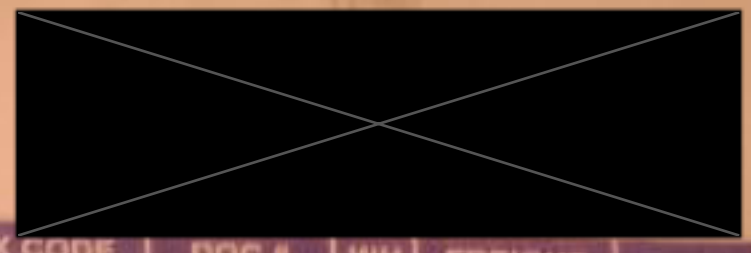

REFERENCE #	SHIPPED	SALESPERSON	TERMS	TAX CODE	DOC #	WH	FREIGHT	SHIP VIA
CRV100	8/1/20/14	279 JRL IUS	MASTER CARD	EXEMPT	487802	01	PREPAID	DRP/100

ITEM DESCRIPTION	ORDERED	SHIPPED	BACKORDERED	UM	PRICE	UM	EXTENSION
THANK YOU FOR THE ORDER 1955 BA 2DR HTP							
1785 Frt Dr Bds, 55 2Dr Htp/Conv	1.00	1.00	.00	P			
1733 Rr Side Bds, 55 BA/210 2Dr Htp	1.00	1.00	.00	P			
8963 Front Anarest Base, 55 HTP/CONV	1.00	1.00	.00	P			
3865 R/Rest Pads, 55 BA Frt Rubber	1.00	1.00	.00	P			
1655 K/Panels, BLK 55 Chevy	1.00	1.00	.00	P			



SINCE 1976

**NOTICE!** Please inspect the contents of  
 s order immediately upon receipt. All  
 MUST be reported

----- TRANSACTION RECORD -----  
SOUTHEAST CHEVY PARTS IN  
2166 S. ORANGE BLOSSOM T  
APOPKA, FL 32703  
United States  
SOUTHEASTCHEVYPARTS.COM

TYPE: Purchase

ACCT: Visa \$ 229.00 USD

CARDHOLDER NAME :   
CARD NUMBER :   
DATE/TIME : 22 Jan 14 09:47:59  
REFERENCE # : 001 0259235 M  
AUTHOR. # : 022789  
TRANS. REF. :

Approved - Thank You 100

Please retain this copy for your records.

Cardholder will pay above amount to card issuer pursuant to cardholder agreement.

=====



# ECKLER'S

FAMILY OF AUTOMOTIVE SALES COMPANIES

CUSTOMER SERVICE  
1-800-327-4848



Customer No.	Order No.	Order Description	
21901997-000	08176775-00001	8/27/14	8/27/14
VIN No.	Vehicle No.	Order Date	Page
014	000000000000000000	7/26/14	1
Class	Product	Order Type	
		RTL	
Ship Via		VISA CARD	

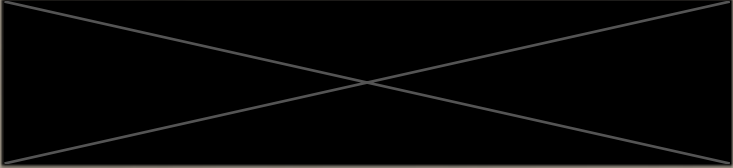

Quantity	Part No.	Part Name	Description	UOM	Unit Price	Sale Price	Amount
1	02-02	SEA	Seat Adjuster Knob, 55-57	SEA	0	10.44	10.44
1	02-04	SEA	Seat Adjuster Knob Base, 55-57	SEA	0	13.20	13.20
1	05-18	ST	Seat Back Stops, Pvc Lwr, 55-56	SEA	0	9.48	9.48



Cust. #: 21901997-000  
Order #: 08176775-00001

INSPECT CONTENTS OF SHIPMENT FOR DAMAGES AND SHORTAGES WITHIN 5 DAYS

Sale Amount	33.22
Shpg & Hndg	8.20
Sales Tax	2.90
Pkg Protect	.00
COO Charges	.00
<b>Total</b>	<b>44.32</b>
Prepayment	44.32
Balance Due	.00

# ECKLER'S

5225 South Washington Ave.  
Titusville, FL 32780  
ATTN: RETURNS DEPT.

Comments:  
**RTL**







----- TRANSACTION RECORD -----  
SOUTHEAST CHEVY PARTS IN  
2166 S. ORANGE BLOSSOM T  
APOPKA, FL 32703  
United States  
SOUTHEASTCHEVYPARTS.COM

TYPE: Purchase

ACCT: Visa \$ 1,462.00 USD

CARDHOLDER NAME :   
CARD NUMBER :   
DATE/TIME : 17 Jan 14 18:46:47  
REFERENCE # : 001 0383467 M  
AUTHOR. # : 017736  
TRANS. REF. :

Approved - Thank You 100

Please retain this copy for your records.

Cardholder will pay above amount to card issuer pursuant to cardholder agreement.

=====



# Southeast Chevy Parts

1955-1972 Classic Chevrolet Parts

2166 South Orange Blossom Trail, Apopka, FL 32703 • Ph 407.886.1963 • Fx 407.886.1958  
dhowell@southeastchevy.com • www.SoutheastChevyParts.com

Facebook Twitter @SEChevyParts

ORDER: Phone / Website

DATE: 1/16/14

### SHIPPING ADDRESS

NAME: [REDACTED]  
 COMPANY: [REDACTED]  
 ADDRESS 1: [REDACTED]  
 ADDRESS 2: [REDACTED]  
 CITY/ST/ZIP: Gaines City FL 33844  
 COUNTRY: [REDACTED]  
 PHONE: [REDACTED]  
 EMAIL: [REDACTED]

### BILLING ADDRESS

Same as Shipping

NAME: \_\_\_\_\_  
 COMPANY: \_\_\_\_\_  
 ADDRESS 1: \_\_\_\_\_  
 ADDRESS 2: \_\_\_\_\_  
 CITY/ST/ZIP: \_\_\_\_\_  
 COUNTRY: \_\_\_\_\_  
 PHONE: \_\_\_\_\_  
 FAX: \_\_\_\_\_

VEHICLE: 1955 2dr Htp

SHIPPING: \_\_\_\_\_  
 PAYMENT: CREDIT CHECK CASH

QTY	DESCRIPTION	PRICE	TOTAL
1 pr	Full Brackets to mount Arm rests to doors		25.00
1 pr	Vertical only w/r seat shells		230.00
1 set	All floor + qtr + kick panel cardboard		190.00
1 pr	Dome lenses + housings		75.00
1 pr	Door sill plates		60.00
1 pr	Junior rocker covers		60.00
1 pr	Original kick panel retainers		170.00
1 pr	Original Arm rest pulls (cups)		18.00
1	grayish screw set		7.00
1 set	dash trays - rear		85.00
1 pr	concent 55 Htp metal arm rests		125.00
1 pr	" " " " pads		85.00
1 pr	vert vent strips		50.00
1 set	of vent rubber		65.00

NOTES:

SUBTOTAL 1325.00  
 TAX (FL) 85.95  
 SHIPPING & INSURANCE 57.05  
 GRAND TOTAL 1468.00

THANK YOU FOR DOING BUSINESS WITH SECHEVY

RETURN POLICY - ITEMS MAY BE RETURNED WITHIN 30 DAYS OF PURCHASE

used.

✓ Both door pull brackets + screws ~~20.00~~ 25.00  
└ shaped =  
Regulation screws 1/4" x 1/2

✓ Back of frt Seat corner trim =  
54-27 Seat Shells 199.99 set = ~~170.00~~ 200.00

~~46-01~~ ~~card board~~

46-01 X door panels 44.99 ✓ 115.00

46-16 X Kick panels 13.99 ✓

46-03 X quarter panels 25.99 ✓

02-14 door lights + lens 36.99 each ✓

used? 11-44 ✓ chrome door sills 52.99 ✓ + screws

✓ 31-284 Kick panels - wind lace retainers 197.99 ✓ used OEM 170.00

31-26 ✓ door sill plates - Rocker Panel Covers 42.99 pr ✓

07-110 X arm rests 219.99 ✓

07-63 X arm rest pad 79.99 ✓

07-22 ✓ arm rest pulls 11.99 each ✓

34-48 garnish Arch screws 5.99 ✓

36-321 } window glass kits } 999.99 ✓

} tinted one }

02-57 ✓ ash trays rear pr. 69.99 ✓

429 M  
414 E  
441  
4 miles  
1/2 N

have set of glass - sides - tinted  
some window frames

220.00  
260.00  
45 credit

1852.95  
+ tax

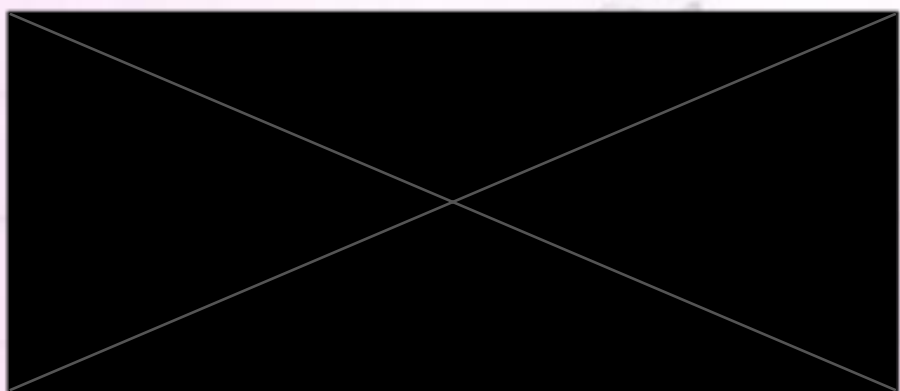





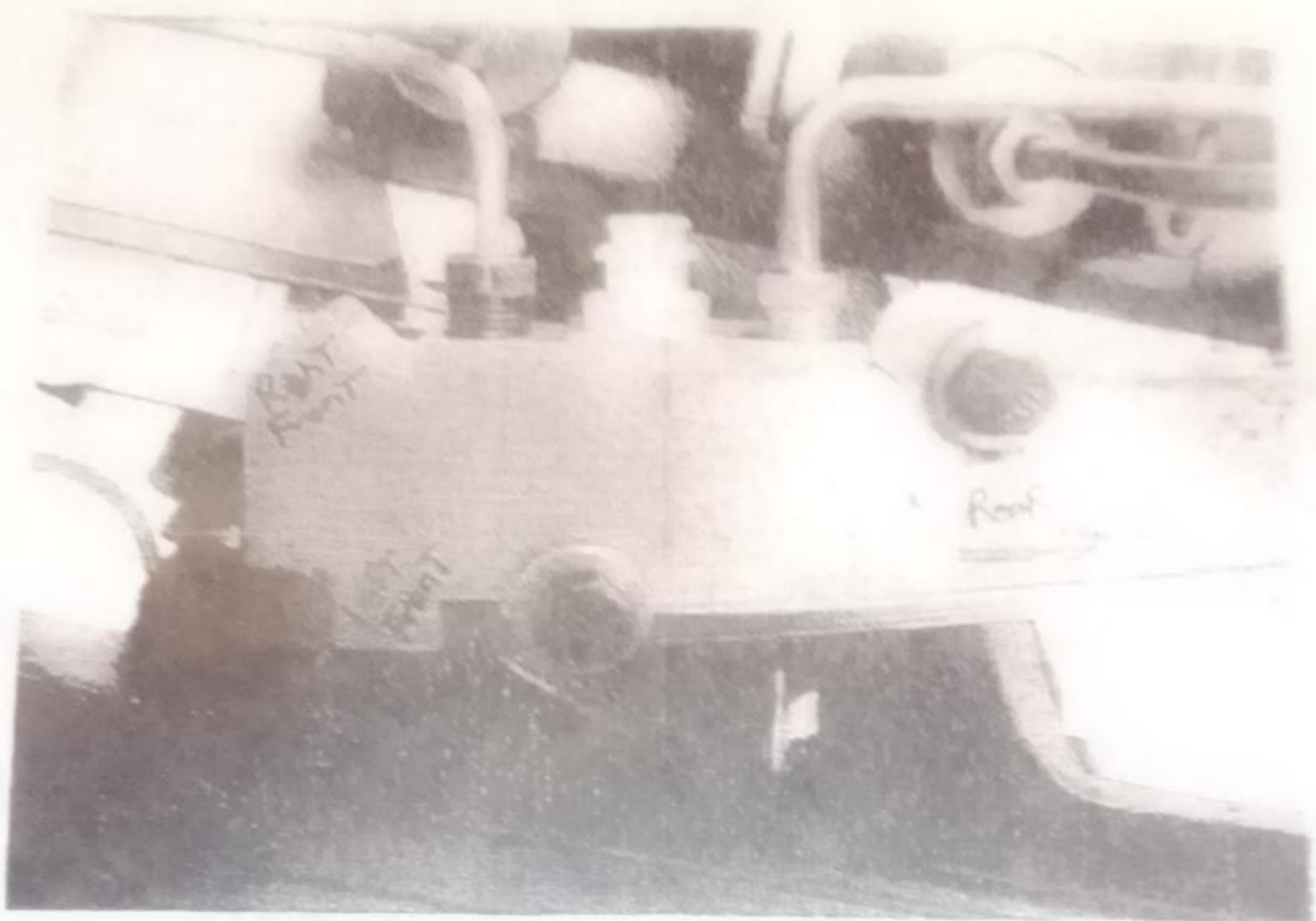

PK11R0  
WM

PACKING SLIP

Var

7/16/14

Wh/Co/Div : 28E 28E

Pkt Ctl# : 2011747476

Load / Ship : /  
BOL # : 000000000

From : MTD Shelby Operations  
305 Mansfield Ave.  
Shelby Ohio 44875

COM Order : 55 3845957 001  
PO# : CDS394296014

Customer [Redacted]

Ship To: [Redacted]

FRT Term : Prepaid  
FOB Term : FOB Ship Point  
Ship Via : SMTP FedEx Smart Pos

Mfg Due : 7/13/2014  
Ship To : QV004424  
Store# :  
Dept :

Pro # :  
Seal # :  
Trailer # :  
MTD Load :  
Cust Load# :

RESIDENTIAL DELIVERY Get your Fall and Winter Troy-Bilt equipment now! Call us at 1-800-828-5500 or visit us on the web at TroyBilt.com No Sales Tax applied to Factory Direct sales shipped outside Ohio. Free shipping & financing available on most models. PHONE: (853) 421-9054

Item	Description	Unit Weight (Lb/Ea)	Skid No.	Qty Ordered	Qty Shipped	Price
954-0350 Ln# 1	BELT-V 5/8 X 64.5	.80		1	1	38.12
954-0349 Ln# 2	BELT	.65		1	1	29.59
942-0644 Ln# 3	BLADE-2 IN 1 STAR 16	1.50		2	2	35.70
942-0645 Ln# 4	BLADE-2 IN 1 STAR 14	1.70		1	1	17.24

Totals : 5.75 5 Sub-Total 120.65

Your order has been charged to your Credit Card Account  
For questions regarding this order or to obtain return authorization call 1-800-269-6215.

Tax .00  
Freight 16.99  
Total 137.64

1 cartons

\*\*\* End Of Report \*\*\*

# Invoice

*Emo's*

Emo's Upholstery & Window Repair  
1020 North Combee Rd  
Lakeland, FL 33801  
863-666-6994

Date	Invoice #
10/22/2012	16321

Bill To	
customer walk in	

P.O. No.	Terms	Project

Description	Qty	Rate	Amount
headliner board only w/ 2127 saddle tan - customer pulled board and will reinstall board himself		50.00	50.00
VISORS		25.00	25.00
<i>cash</i>			
<b>Subtotal</b>			\$75.00
<b>Sales Tax (7.0%)</b>			\$5.25
<b>Total</b>			\$80.25
<b>Payments/Credits</b>			\$-40.00
<b>Balance Due</b>			<u>\$40.25</u>

*Emo's*

Emo's Upholstery & Window Repair  
1020 North Combee Rd  
Lakeland, FL 33801  
863-666-6994

Invoice

Date	Invoice #
10/23/2012	10121

Bill To
Customer work in 

P.O. No	Terms	Project

Description	Qty	Rate	Amount
headliner board only with 2127 middle tape - customer pulled board and will reinstall board himself		50.00	50.00
VISCORS		25.00	25.00
<b>Subtotal</b>			\$75.00
<b>Sales Tax (7.0%)</b>			\$5.25
<b>Total</b>			\$80.25
<b>Payments/Credits</b>			\$-40.00
<b>Balance Due</b>			\$40.25



TUBES N' HOSES  
 LAKELAND, INC  
 2252 E. Edgewood Dr.  
 Lakeland, FL 33803  
 Phone 863-686-0101  
 Cell Phone 863-255-5053



Hydraulic Hoses, Custom  
 Steel Lines, Air Conditioner  
 Hoses, Power Steering Hoses,  
 Control Cables, DOT Flex  
 Brake Hoses, Custom  
 Fabrication

Bill To

Ship To

Invoice #

RETAIL

4789

55 HT

Date

4/20/2009

Customer Phone	P.O. Number	Terms	Ship	Via
		Due on receipt	4/20/2009	CUSTOMER P.

Item Code	Quantity	Description	Price Each	Amount
HF10	1	MALE SWIVEL	6.90	6.90
BQMSGY	1	INSERT	4.95	4.95
		Fuel line		

Subtotal 51.85

Sales Tax (7.0%) 3.63

Total 55.48

Web Site

www.tnhlakeland.com

THANK YOU FOR YOUR  
 BUSINESS

# ECKLER'S

FAMILY OF AUTOMOTIVE PARTS COMPANY  
 CERTIFICATED • PERFORMANCE ESTIMATES

CONTINENTAL SALES/CO  
 1-800-827-1808

55 HT



Bill To:



Part No.	Part Name	Price	Quantity	Total
2201217 000	CLIPPER 2201217	8.99	1	8.99
2201217 000	CLIPPER 2201217	8.99	1	8.99
2201217 000	CLIPPER 2201217	8.99	1	8.99
2201217 000	CLIPPER 2201217	8.99	1	8.99
2201217 000	CLIPPER 2201217	8.99	1	8.99
2201217 000	CLIPPER 2201217	8.99	1	8.99
2201217 000	CLIPPER 2201217	8.99	1	8.99
2201217 000	CLIPPER 2201217	8.99	1	8.99
2201217 000	CLIPPER 2201217	8.99	1	8.99
2201217 000	CLIPPER 2201217	8.99	1	8.99

Bill To:



Part No.	Part Name	Price	Quantity	Total			
823-05-28	08-13	1	07	Clutch Pedal Bracket & Pump Kit, 55-56	8.99	8.99	8.99
823-11-01	05-10	1	0A	Spoke design Bellows, Set ALV, 55-56	7.99	7.99	7.99
823-05-02	03-03	1	00	Parking Light Assembly, Complete, 1955	122.99	122.99	122.99



Cart #: 22042019 000  
 Order #: 04146001 00001

INSPECT CONTENTS OF SHIPMENT FOR DAMAGES AND DEFICIENCIES WITHIN 5 DAYS		Sale Amount	147.97
FICK		Ship & Body	19.99
PRICE		Sales Tax	11.86
		Fly Protect	1.50
		OD Charges	.00
		Total	181.32
		Prepayment	181.32
		Balance Due	.00

## ECKLER'S

5225 South Washington Ave.  
 Titusville, FL 32780  
 ATTN: RETURNS DEPT.

Comment:  
RTL

# ECKLER'S

FAMILY OF AUTOMOTIVE PARTS COMPANY

CUSTOMER SERVICE  
1-800-327-4448

Customer No.	Order No.	Invoice Date
04023748-0001		7/18/05

# ECKLER'S

FAMILY OF AUTOMOTIVE PARTS COMPANY  
CORVETTE - PERFORMANCE PRODUCTS

CUSTOMER SERVICE  
1-800-327-4448

Customer No.	Order No.	Invoice Date	Invoice No.
04023748-0001	04023748-0001	7/18/05	7/18/05
Part No.	Part Name	Order Date	Order No.
812	800865274	7/13/05	1
Qty	Part Name	Order Type	Order Number
1	800865274	STD	
Ship Via		Terms	
VISA (0000)		VISA (0000)	

55 HT



Part No.	Part Name	Qty	Unit Price	Description	UOM	Unit Price	Subtotal	Amount
812-01-02	88-18	1	59.99	Cable, Emergency Brake, Rear, 55-57	USA	59.99	59.99	59.99
829-07-05	22-05	1	24.99	Emergency Brake Handle, Chrome, 55-57	USA	24.99	24.99	24.99



Cart. #: 22641819-000  
Order #: 04023748-0001

INSPECT CONTENTS OF  
SHIPMENT FOR DAMAGES AND  
SHORTAGES WITHIN 5 DAYS

PICK	PACK

Sale Amount	64.98
Ship & Hndg	14.99
Sales Tax	7.06
My Protect	.95
OD Charges	.00
Total	107.98
Prepayment	107.98
Balance Due	.00

# ECKLER'S

5225 South Washington Ave.  
Titusville, FL 32780  
ATTN: RETURNS DEPT.

Comments:

# RTL

# ECKLER'S

FAMILY OF AUTOMOTIVE PARTS COMPANIES

CUSTOMER SERVICE  
1-800-329-4388



ORDER NO.	DATE	TIME
21901997-000	07/29/87	0000
STK NO.	DATE	TIME
001	00/11/01	0000
STK	E.O. NUMBER	DATE
000		
SHIP VIA		
REGWAY (0000)		VISA CARD



LOCATION	Part No.	QTY	DESCRIPTION	UNIT	UNIT PRICE	UNIT VALUE	TOTAL
AK-KR-ER	000	1	SA Express Service, Rush Ship 2-1	UNL	0	3.99	.00
013-03-15	01-C4	1	SA Trunk Emblem Assembly, 7 Cy Order, 88-54	UNL	0	87.50	87.50



Cust. #: 21901997-000  
Order #: 07294037-00001

INSPECT CONTENTS OF  
SHIPMENT FOR DAMAGES AND  
SHORTAGES WITHIN 5 DAYS

PICK	PACK

Sale Amount	87.50
Shpg & Hndg	7.48
Sales Tax	6.79
Pkg Protect	.95
CGO Charges	.00
Total	102.86
Prepayment	102.86
Balance Due	.00

# ECKLER'S

5225 South Washington Ave.  
Titusville, FL 32780  
ATTN: RETURNS DEPT.

Comments:

# RUSH