



HYDRAULICS DATA BOOK



TABLE OF CONTENTS

What is Hydraulics?	3
Hydraulic Graphic Symbols	4
Hydraulic Pumps	9
Pump Formulas	10
Horsepower to Drive a Pump/Quick Reference Chart:	11
Determining Pump Displacement	12
Hydraulic Cylinders (Actuators)	13
Cylinder Formulas	14
Cylinder Force / Quick Reference Chart	15
Hydraulic Cylinder Speed / Quick Reference Chart	17
Power Unit Reservoir Requirements	19
Hydraulic Motors (Actuators)	20
Motor Formulas	21
Hydraulic Directional Control Valve Definitions	22
Valve Spool Configurations Definitions	23
Power Unit Battery Cable Selection	25
Hydraulic Fittings	27
Proper Hydraulic Hose Installation Guidelines	32
Hose Size Selection Tool	34
Hose Size Selection Nomograph	35
Hydraulic System Pressure Drop	36
Hydraulic Hose Pressure Drop Chart	37
Hydraulic Oil and Filtration	38
Viscosity Comparison Chart	38
What is Beta Ratio?	39
ISO Cleanliness Code for Hydraulic Oil	40
Selecting Your Hydraulic Filter	41
The Hydraulic Reservoir	43
Seal Compatibility Table	44
Hydraulic System Troubleshooting	45
Conversion Tables	48
Hydraulic Oil and Filtration	38
How to Determine Belt Length	52
How To Determine The Size and Speed of Pulleys and Sprockets	52
Electrical	55
Basic Electrical Formulas	56
The Electrical Formula Wheel	57
Ongoing Commitment To Training	58
Glossary	59

WHAT IS HYDRAULICS?

Hydraulics in its most basic definition is the use of liquids to perform work.

What are the major components?

- Reservoir
- Pump
- Directional Control Valve
- Prime Mover (Gas Engine, Electric Motor)
- Hydraulic Cylinder or Hydraulic Motor

How does a hydraulic system work?

1. The reservoir stores and supplies hydraulic oil to the pump.
2. Oil travels from the reservoir through the strainer to the pump.
3. The prime mover rotates the pump shaft. This draws oil from the reservoir into the pump.
4. The pump sends hydraulic oil to the directional control valve.
5. If the pressure exceeds a safe preset level, the oil will be directed through the relief valve to the reservoir.
6. The directional control valve controls the direction of the hydraulic oil flow.
7. The direction of the hydraulic oil determines if the cylinder will either extend or retract.
8. Hydraulic oil returns from the cylinder, through the control valve and filter, and back to the reservoir.

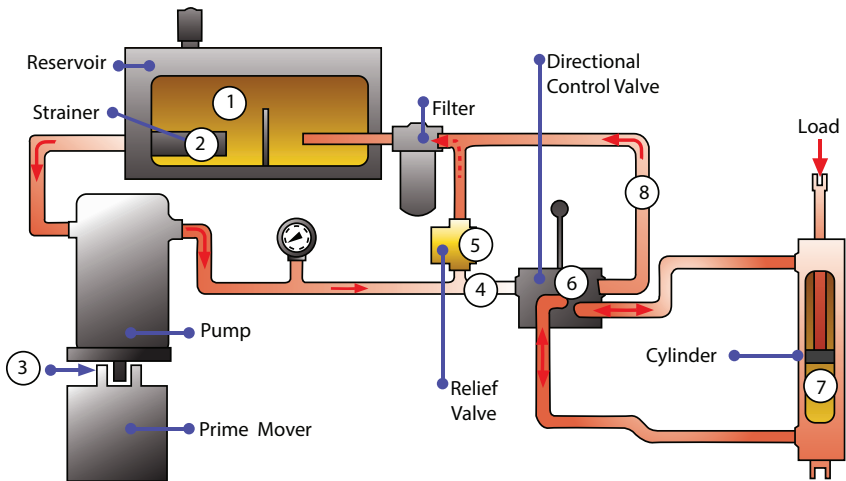

HYDRAULIC GRAPHIC SYMBOLS

PUMPS

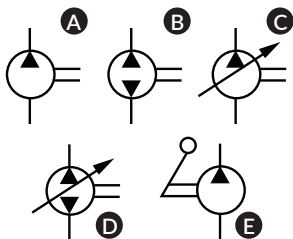

A	One flow direction	Fixed Displacement Pump
B	Two flow directions	
C	One flow direction	Variable Displacement Pump
D	Two flow directions	
E	One flow direction	Hand Pump

MOTORS

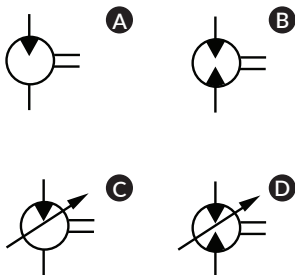

A	One rotation direction	Fixed Displacement Motor
B	Two rotation directions	
C	One rotation direction	Variable Displacement Motor
D	Two rotation directions	

CHECK VALVES

Standard	Spring Loaded	Pilot Operated	Pilot with Drainage

DIRECTIONAL VALVES

2-Way 2 Position	3-Way 2 Position	4-Way 2 Position	4-Way 3 Position

CONTROL FOR DIRECTIONAL VALVES

Mechanical	Push Button	Lever	Pedal

Spring	Cam	Electric (Solenoid)	Electro-hydraulic

Pneumatic	Hydraulic	Electric (Proportional)	Electro-hydraulic (Proportional)

PRESSURE CONTROL VALVES

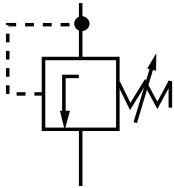
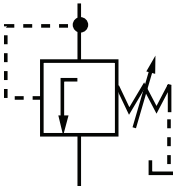
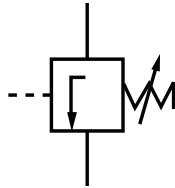
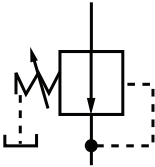
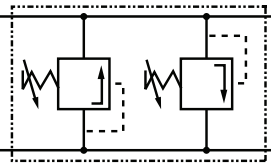
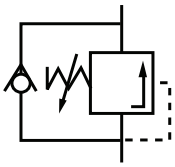
<p>Pressure Relief Valve</p> 	<p>Sequence Valve</p> 	<p>Unloading Valve</p> 
<p>Pressure Reducing Valve</p> 	<p>Crossover Relief Valve</p> 	<p>Counterbalance Valve</p> 

FLOW CONTROL VALVES

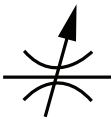
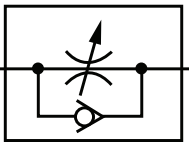
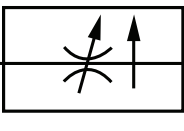
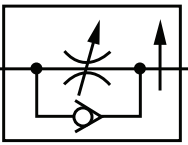
<p>Throttle Valve</p> 	<p>Throttle with Reverse Check</p> 	<p>Pressure Compensated Flow Control</p> 	<p>Pressure Compensated Flow Control with Reverse Check</p> 
---	--	--	---

CYLINDERS

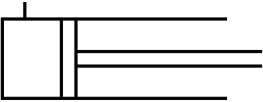
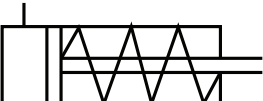
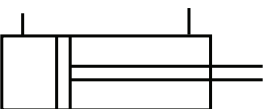
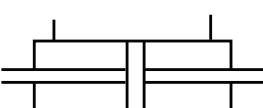
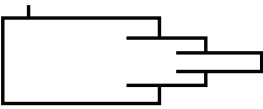
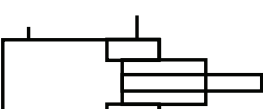
	Single-acting Cylinder	Return Stroke by External Force
		Return Stroke Through a Spring
	Double-acting Cylinder	Single Rod
		Double Rod
	Telescopic Cylinder	Single-acting
		Double-acting

SEARCH "HYDRAULICS" ON PRINCESSAUTO.COM

Explore a huge selection of cylinders, power units, reservoirs, filters, gauges, coolers, valves, manifolds, pumps, motors, connectors, thread seal tape, and hydraulic oil, hoses and fittings.

Remember: You can choose from pre-made hoses, or we'll make one to your specifications! Plus, we offer free hose cutting, cleaning and crimping for all hydraulic hose and fittings purchased at Princess Auto!

ENERGY TRANSMISSION AND ACCESSORIES

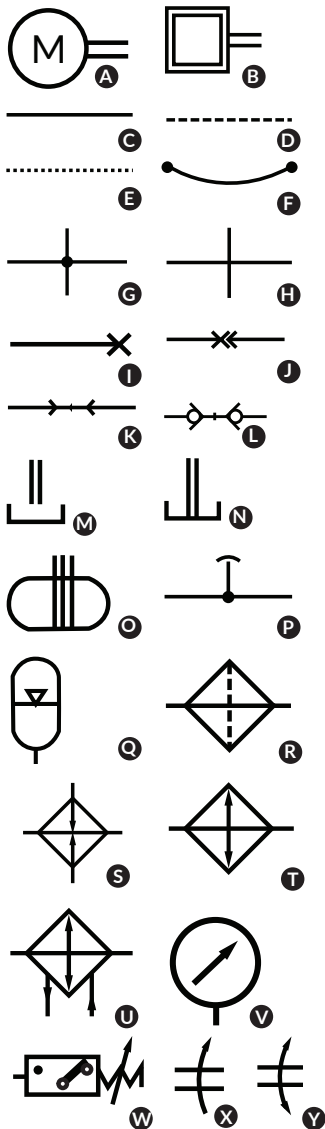

Prime Mover	A	Electric Motor	
	B	Gas Engine	
Piping and Connections	C	Main	
	D	Pilot	
	E	Drain	
	F	Flexible Hose	
	G	Connection Point	
	H	Crossing	
	Branching	I	Closed
		J	With Connected Piping
Coupling	K	Fast Coupling	
	L	With Check Valves	
Reservoir	M	Piping Above Level	
	N	Piping Under Level	
	O	Pressurized Reservoir	
Air Bleed	P	---	
Hydraulic Accumulator	Q	---	
Filter	R	---	
Heat Exchanger	S	Heater	
	T	Cooler	
	U	Liquid Operated Cooler	
Pressure Gauge	V	---	
Pressure Switch	W	Adjustable	
Rotating Shaft	X	1 Direction	
	Y	2 Direction	

HYDRAULIC PUMPS

The basic function of a hydraulic pump is to take fluid that is provided at the inlet and discharge it through the outlet into a hydraulic system. Hydraulic pumps convert the mechanical energy transmitted by its prime mover (electric motor or gas engine) into hydraulic working energy.

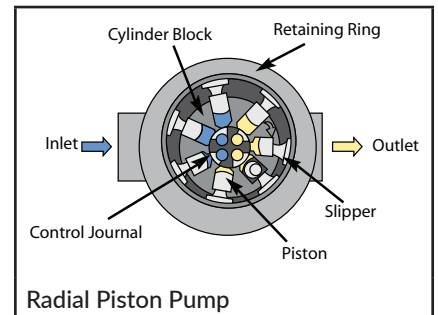
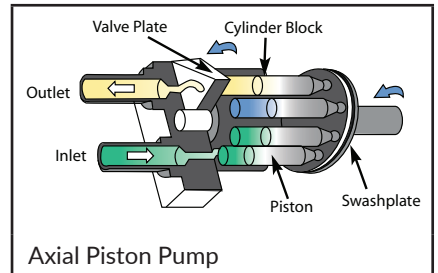
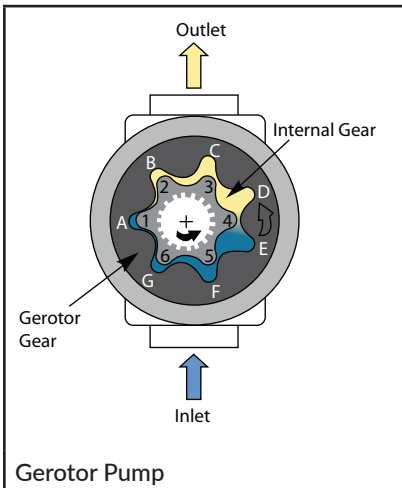
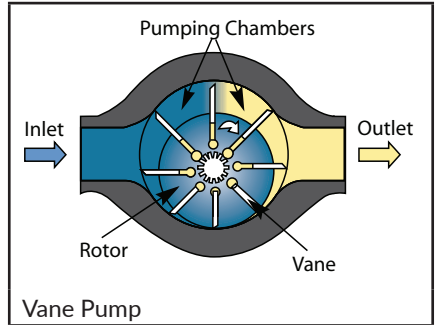
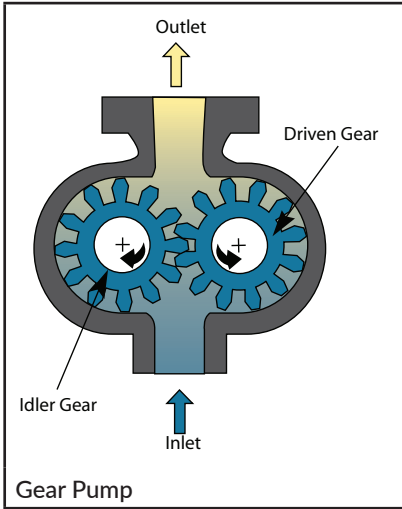

PUMP FORMULAS

Calculating Pump Flow

To determine the flow of a pump you need to know the displacement of the pump and the speed (RPM) of the prime mover.

$$\text{Pump flow (GPM)} = \frac{\text{Pump Displacement (cu. in./rev.)} \times \text{Pump Speed (RPM)}}{231}$$

Example: How many gallons per minute (GPM) can a pump produce that has a displacement of 0.269 cu. in./rev. and is running at 3,000 RPM?

$$\text{Pump flow (GPM)} = \frac{0.269 \text{ cu. in./rev.} \times 3,000 \text{ RPM}}{231} = 3.49 \text{ GPM}$$

Calculating Horsepower to Drive a Pump

To determine the horsepower to drive a pump, you need to know the pump flow and pressure.

$$\text{Horsepower (To drive a pump)} = \frac{\text{Pressure (PSI)} \times \text{Flow (GPM)}}{1714 \times \text{Pump efficiency}}$$

Example: How many horsepower would I require to drive a gear pump that will produce 15 GPM at 2,500 PSI?

Pump efficiency
Gear - 0.85
Vane - 0.90
Piston - 0.95

$$\text{Horsepower (To drive a pump)} = \frac{2,500 \text{ PSI} \times 15 \text{ GPM}}{1714 \times 0.85 \text{ (Pump efficiency)}} = 25.7 \text{ HP}$$

HYDRAULIC TIP:

Approximate horsepower requirements for a hydraulic system can be calculated with this simple formula:

1 HP is required for every 1 GPM @ 1,500 PSI

As an example, a 3 GPM pump operating at 1,500 PSI would require 3 HP. At 3,000 PSI it would require 6 HP.

This easy formula will allow you to make quick mental calculations to determine the approximate HP requirements of a hydraulic system.

HORSEPOWER TO DRIVE A PUMP/QUICK REFERENCE CHART: (USING 85% PUMP EFFICIENCY)

GPM	500 PSI	750 PSI	1,000 PSI	1,250 PSI	1,500 PSI	1,750 PSI	2,000 PSI	2,500 PSI	3,000 PSI
1/2	0.17	0.26	0.34	0.43	0.52	0.60	0.69	0.86	1.0
1	0.34	0.52	0.67	0.86	1.0	1.2	1.4	1.7	2.0
1-1/2	0.52	0.77	1.0	1.3	1.5	1.8	2.1	2.6	3.0
2	0.67	1.0	1.4	1.7	2.1	2.4	2.8	3.4	4.1
2-1/2	0.86	1.3	1.7	2.1	2.6	3.0	3.4	4.3	5.2
3	1.0	1.5	2.1	2.6	3.1	3.6	4.1	5.2	6.2
3-1/2	1.2	1.8	2.4	3.0	3.6	4.2	4.8	6.0	7.2
4	1.4	2.1	2.8	3.4	4.1	4.8	5.5	6.9	8.2
5	1.7	2.6	3.4	4.3	5.2	6.0	6.9	8.6	10.3
6	2.1	3.1	4.1	5.2	6.2	7.2	8.2	10.3	12.4
7	2.4	3.6	4.8	6.0	7.2	8.4	9.6	12.0	14.4
8	2.8	4.1	5.5	6.7	8.2	9.6	11.0	13.7	16.5
9	3.1	4.6	6.2	7.7	9.3	10.8	12.4	15.4	18.5
10	3.4	5.2	6.9	8.6	10.3	12.0	13.7	17.2	20.6
12	4.1	6.2	8.2	10.3	12.4	14.4	16.5	20.6	24.7
15	5.2	7.7	10.3	12.9	15.4	19.0	20.6	25.7	30.9
20	6.7	10.3	13.7	17.2	20.6	24.0	27.5	34.3	41.2
25	8.6	12.9	17.2	21.4	25.7	30.0	34.3	42.9	51.5
30	10.3	15.4	20.6	25.7	30.9	36.0	41.2	51.5	61.8
35	12.0	18.0	24.0	30.0	36.0	42.0	48.0	60.0	72.1
40	13.7	20.6	24.0	34.3	41.2	48.0	54.9	68.6	82.4
45	15.4	23.2	30.9	38.6	46.3	54.1	61.8	77.2	92.7
50	17.2	25.7	34.3	42.9	51.5	60.0	68.6	85.8	103.0

DETERMINING PUMP DISPLACEMENT

Gear Pump

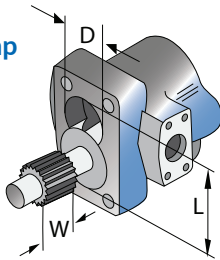

1. Measure the gear width (W).
2. Measure bore diameter of one of the gear chambers (D).
3. Measure distance across both gear chambers (L).

$$CIR^* = 6 \times W \times (2D - L) \times \frac{(L - D)}{2}$$

*Cubic inches/revolution

Vane Pump

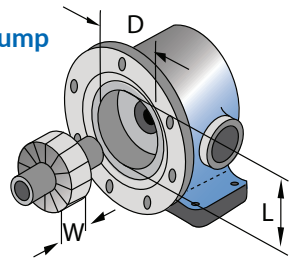

1. Measure the rotor width (W).
2. Measure the shortest diameter of the elliptical bore (D).
3. Measure the longest diameter of the elliptical bore (L).

$$CIR^* = 12 \times W \times \frac{(L+D)}{4} \times \frac{(L-D)}{2}$$

PUMP/MOTOR FLANGES TABLE

SAE - 2 Bolt Mount

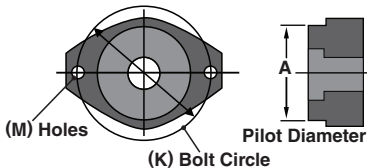

SAE - 4 Bolt Mount

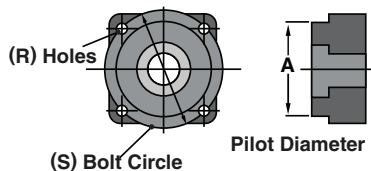

Mounting Flange	Pilot Dim.	Bolt Circle	Bolt Holes
	A	K	M
SAE AA	2.000	3.250	0.406
SAE A	3.250	4.187	0.438
SAE B	4.000	5.750	0.562
SAE C	5.000	7.125	0.688
SAE D	6.000	9.000	0.812
SAE E	6.500	12.500	1.062
SAE F	7.000	13.781	1.062

Mounting Flange	Pilot Dim.	Bolt Circle	Bolt Holes
	A	S	R
USA4F17	1.781	2.838	0.375
SAE A	3.250	4.125	0.438
SAE B	4.000	5.000	0.562
SAE C	5.000	6.375	0.562
SAE D	6.000	9.000	0.812
SAE E	6.500	12.500	0.812
SAE F	7.000	13.781	1.062

HYDRAULIC CYLINDERS (ACTUATORS)

Hydraulic cylinders are linear actuators. When they are exposed to hydraulic pressure they produce a pushing or pulling force. The three basic types of hydraulic cylinders are single acting, double acting and telescopic.

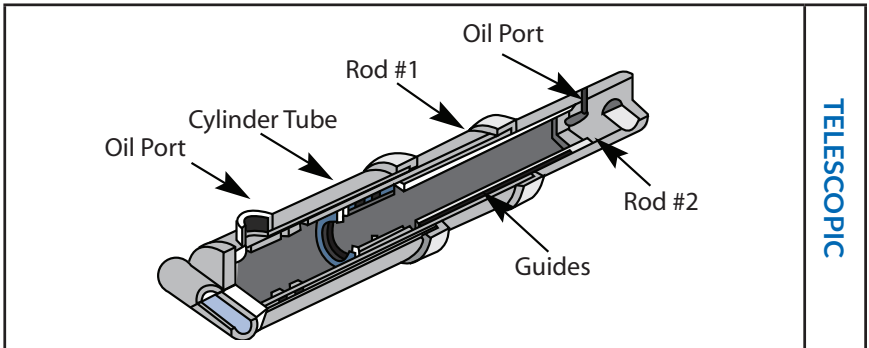
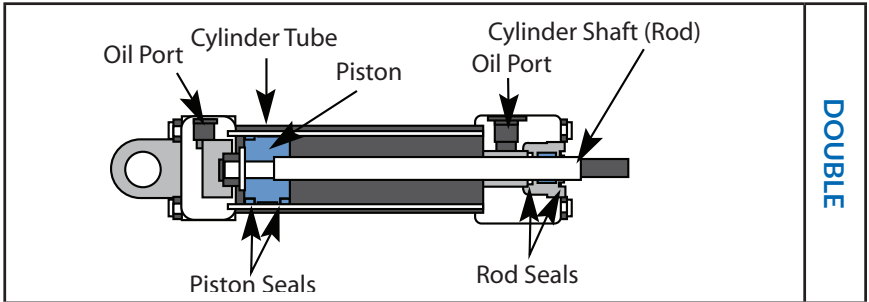
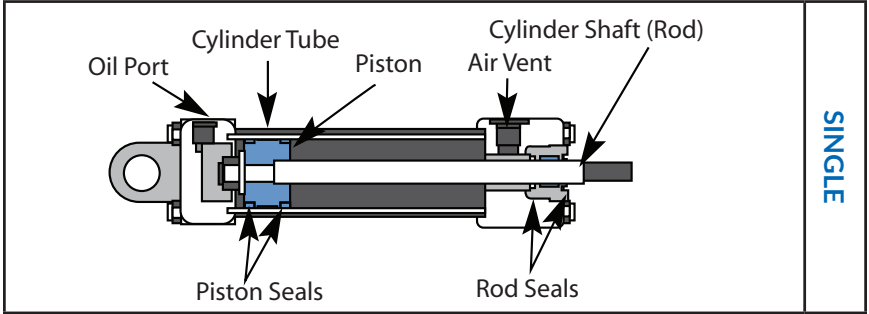

CYLINDER FORMULAS

Calculating Cylinder Force (Extension)

In order to calculate the maximum force a cylinder can produce while extending you need to know the area of the cylinder's piston and the system's maximum pressure.

The following formulas are used in the calculation:

$$\text{Piston Radius (in.)} = \frac{\text{Bore Diameter (in.)}}{2}$$
$$\text{Piston Area (sq. in.)} = \pi \times \text{Piston Radius}^2 \text{ (in.)}$$
$$\text{Cylinder Force (lb)} = \text{Pressure (PSI)} \times \text{Piston Area (sq. in.)}$$

Example: If a cylinder has a 3 in. bore in a system that is delivering 3,000 PSI, how much force can it produce while extending?

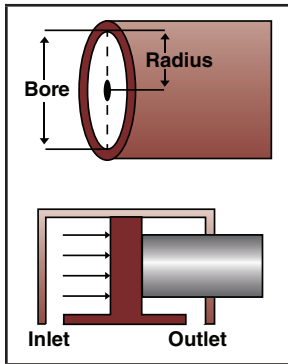

$$\text{Piston Radius} = \frac{3 \text{ in.}}{2} = 1.5 \text{ in.}$$

$$\begin{aligned} \text{Piston Area} &= \pi \times 1.5 \text{ in.}^2 \\ &= 3.14 \times (1.5 \times 1.5) \\ &= 7.065 \text{ sq. in.} \end{aligned}$$

$$\begin{aligned} \text{Cylinder Force} &= 3,000 \text{ PSI} \times 7.065 \text{ sq. in.} \\ &= 21,195 \text{ lb} \end{aligned}$$



**PROUD MEMBER OF THE
Canadian Fluid
Power Association**

**Association canadienne
d'énergie des fluides**

CYLINDER FORCE/QUICK REFERENCE CHART

To determine the max. extension force of the cylinder (in pounds), find the row with the Cylinder Bore in the Bore Dia. column. Choose "None" in the Rod Dia. column next to the bore dimension. Follow across to the column with the pressure (PSI) being used to determine the correct amount of force. For the max. retraction force, repeat the previous instructions and use the closest rod dimension under the Rod Dia. column.

Bore Dia. (in.)	Rod Dia. (in.)	Effective Area (sq. in.)	1,000 PSI	1,500 PSI	2,000 PSI	2,500 PSI	3,000 PSI
1	None	0.79	790	1,185	1,580	1,975	2,370
	5/8	0.48	480	720	960	1,200	1,440
1-1/2	None	1.76	1,760	2,640	3,520	4,400	5,280
	1	0.98	980	1,470	1,960	2,450	2,940
2	None	3.14	3,140	4,710	6,280	7,850	9,420
	1-1/8	2.15	2,150	3,225	4,300	5,375	6,450
	1-1/4	1.91	1,910	2,865	3,820	4,775	5,730
	1-3/4	1.91	1,910	2,865	3,820	4,775	5,730
2-1/2	None	4.91	4,910	7,365	9,820	12,275	14,730
	1-1/8	3.92	3,920	5,880	7,840	9,800	11,760
	1-1/4	3.68	3,680	5,520	7,360	9,200	11,040
	1-1/2	3.14	3,140	4,710	6,280	7,850	9,420
3	None	7.07	7,070	10,605	14,140	17,675	21,210
	1-1/4	5.84	5,840	8,760	11,680	14,600	17,520
	1-1/2	5.30	5,300	7,950	10,600	13,250	15,900
	1-3/4	4.67	4,670	7,005	9,340	11,675	14,010
3-1/2	None	9.62	9,620	14,430	19,240	24,050	28,860
	1-1/4	8.39	8,390	12,585	16,780	20,975	25,170
	1-3/4	7.22	7,220	10,830	14,440	18,050	21,660
	2	6.48	6,480	9,720	12,960	16,200	19,440
4	None	12.56	12,560	18,840	25,120	31,400	37,680
	1-1/4	11.33	11,330	16,995	22,660	28,325	33,990
	1-1/2	10.79	10,790	16,185	21,580	26,975	32,370
	1-3/4	10.16	10,160	15,240	20,320	25,400	30,480
	2	9.42	9,420	14,130	18,840	23,550	28,260
5	2-1/4	8.58	8,580	12,870	17,160	21,450	25,470
	None	19.63	19,630	29,445	39,260	49,075	58,890
	2	16.49	16,490	24,735	32,980	41,225	49,470
	2-1/2	14.72	14,720	22,080	29,440	36,800	44,160

Calculating Cylinder Force (Retraction)

In order to calculate the maximum force a cylinder can produce while retracting you need to know the effective area of the piston and the system's maximum pressure.

The following formulas are used in the calculation:

$$\text{Piston or Rod Radius (in.)} = \frac{\text{Bore or Rod Diameter (in.)}}{2}$$

$$\text{Piston or Rod Area (sq. in.)} = \pi \times \text{Piston}^2 \text{ or Rod Radius}^2 \text{ (in.)}$$

$$\text{Piston Effective Area (sq. in.)} = \text{Piston Area (sq. in.)} - \text{Rod Area (sq. in.)}$$

$$\text{Cylinder Force (lb)} = \text{Pressure (PSI)} \times \text{Piston Effective Area (sq. in.)}$$

Example: A cylinder has a 4 inch bore and a rod 2 inches in diameter, in a system that is delivering 3,000 PSI. How much force can it produce while retracting?

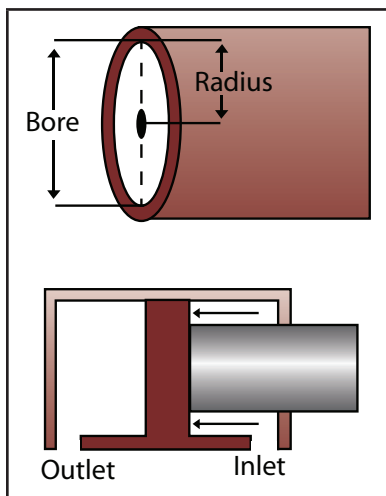

$$\text{Piston Radius} = \frac{4 \text{ in.}}{2} = 2 \text{ in.}$$

$$\text{Rod Radius} = \frac{2 \text{ in.}}{2} = 1 \text{ in.}$$

$$\begin{aligned} \text{Piston Area} &= \pi \times 2^2 \\ &= 3.14 \times (2 \times 2) \\ &= 12.56 \text{ sq. in.} \end{aligned}$$

$$\begin{aligned} \text{Rod Area} &= \pi \times 1^2 \\ &= 3.14 \times (1 \times 1) \\ &= 3.14 \text{ sq. in.} \end{aligned}$$

$$\begin{aligned} \text{Effective Area} &= 12.56 \text{ sq. in.} - 3.14 \text{ sq. in.} \\ &= 9.42 \text{ sq. in.} \end{aligned}$$

$$\begin{aligned} \text{Cylinder Force} &= 3,000 \text{ PSI} \times 9.42 \text{ sq. in.} \\ &= 28,260 \text{ lb} \end{aligned}$$

Calculating Cylinder Speed

To calculate the time it takes a cylinder to fully extend, you need to know the area of the piston, the stroke of the cylinder and the pump's flow.

The following formulas are used in the calculation:

$$\text{Cylinder Volume (cu. in.)} = \text{Piston Area (sq. in.)} \times \text{Cylinder Stroke (in.)}$$

$$\text{Cylinder Speed (sec.)} = \frac{\text{Cylinder Volume (Gal)}}{\text{Pump Flow (GPM)}} \times 60$$

$$\text{Gallons} = \frac{\text{Cubic Inches}}{231}$$

Example: A cylinder has a piston area of 7.065 sq. in. and a stroke of 12 inches (the stroke is the distance between the centres of the 2 ports). If the pump's rate of flow is 2 GPM, how many seconds will it take for the cylinder to extend?

$$\text{Cylinder Volume} = 7.065 \text{ sq. in.} \times 12 \text{ in.} = 84.78 \text{ cu. in.}$$

$$\text{Gallons} = \frac{84.78 \text{ cu. in.}}{231} = 0.367 \text{ or } 0.37 \text{ Gallons (approx.)}$$

$$\text{Cylinder Speed} = \frac{0.37 \text{ Gallons} \times 60}{2 \text{ GPM}} = 11 \text{ sec. to fully extend the cylinder}$$

HYDRAULIC CYLINDER SPEED/QUICK REFERENCE CHART

To determine the cylinder speed (in inches per minute), find the bore of the cylinder. If you are finding the extending speed, use the row with the Rod Diameter of "None". If you are finding the retraction speed, use the row with the Rod Diameter of the cylinder. Follow the row to the closest Pump Flow (GPM).

Bore Dia. (in.)	Rod Dia. (in.)	Effective Area (sq. in.)	Pump Flow (GPM)						
			1 GPM	3 GPM	5 GPM	8 GPM	12 GPM	15 GPM	20 GPM
			Cylinder Speed (inches per minute)						
1	None	0.79	292	876	1,460	2,336	3,504	4,380	5,840
	5/8	0.48	481	1,443	2,405	3,848	5,772	7,215	9,620
1-1/2	None	1.76	131	392	654	1,048	1,572	1,965	2,620
	1	0.98	236	708	1,180	1,888	2,832	3,540	4,720
2	None	3.14	74	221	368	588	882	1,110	1,480

continued on next page

Bore Dia. (in.)	Rod Dia. (in.)	Effective Area (sq. in.)	Pump Flow (GPM)						
			1 GPM	3 GPM	5 GPM	8 GPM	12 GPM	15 GPM	20 GPM
			Cylinder Speed (inches per minute)						
	1-1/8	2.15	107	321	535	856	1,284	1,605	2,140
	1-1/4	1.91	121	363	605	968	1,452	1,815	2,420
2-1/2	None	4.91	47	141	235	376	565	706	941
	1-1/8	3.92	59	177	295	472	708	885	1,180
	1-1/4	3.68	63	189	315	504	756	945	1,260
	1-1/2	3.14	74	221	368	688	882	1,110	1,480
3	None	7.07	33	98	163	261	392	490	654
	1-1/4	5.84	40	120	200	320	480	600	800
	1-3/4	5.30	44	131	218	349	523	654	871
	1-3/4	4.67	49	147	245	392	588	735	980
3-1/2	None	9.62	24	72	120	192	288	360	480
	1-1/4	8.39	28	83	138	220	330	413	550
	1-3/4	7.22	32	96	160	256	384	480	640
	2	6.48	36	107	178	285	428	535	713
4	None	12.56	18	55	92	147	221	276	368
	1-1/4	11.33	20	61	102	163	244	306	407
	1-1/2	10.79	21	63	105	168	252	315	420
	1-3/4	10.16	23	68	114	182	273	341	455
	2	9.42	25	74	123	196	294	368	490
	2-1/4	8.58	27	81	135	216	324	405	540
5	None	19.63	12	35	59	94	141	176	230
	2	16.49	14	42	70	112	168	210	280
	2-1/2	17.72	16	47	78	125	188	235	314

POWER UNIT RESERVOIR REQUIREMENT

When installing a hydraulic power unit for a cylinder application, it is important to make sure the reservoir is the correct size. You must remember the reservoir should only be filled to 80% of its capacity. Depending on the duty cycle of the application, the reservoir may need to be larger to help dissipate the heat. These calculations will help you determine the volume of oil in the cylinder.

For single acting cylinders, use the following calculation:

$$\text{Cylinder Volume (Gallons)} = \frac{\text{Piston Area (sq. in.)} \times \text{Cylinder Stroke (in.)}}{231}$$

$$\text{Piston Area (sq. in.)} = \pi \times \text{Piston Radius}^2 \text{ (in.)}$$

For double acting cylinders, use the following calculation:

The double acting cylinder has oil in both the rod and base end of the cylinder. To extend the cylinder, oil from the power unit reservoir is pumped to the base end of the cylinder, while at the same time oil is being returned to the reservoir from the rod end of the cylinder. During retraction, oil from the power unit reservoir is pumped to the rod end of the cylinder while at the same time oil is being returned to the reservoir from the base end of the cylinder. This transfer of oil in the double acting cylinder means the amount of oil change in the reservoir is equal to the volume of the cylinder's rod.

These calculations will help you determine the volume of the cylinder's rod

$$\text{Cylinder Rod Volume (Gallons)} = \frac{\text{Rod Area (sq. in.)} \times \text{Cylinder Stroke (in.)}}{231}$$

$$\text{Rod Area (sq. in.)} = \pi \times \text{Radius}^2 \text{ (in.)}$$

HYDRAULIC MOTORS (ACTUATORS)

Hydraulic motors transform hydraulic working energy into rotary mechanical working energy, which is applied to a resisting object by means of a shaft. All motors consist of a housing with inlet and outlet ports and a rotating shaft. Hydraulic motors can be uni-directional or bi-directional.

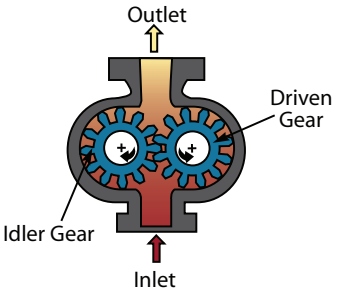
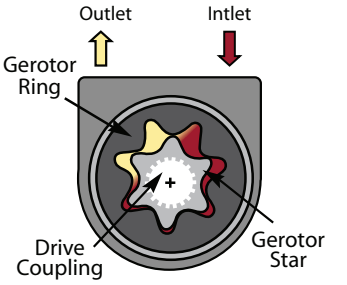
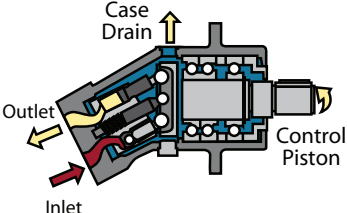
<p style="writing-mode: vertical-rl; transform: rotate(180deg);">Gear Motor</p>		<p style="writing-mode: vertical-rl; transform: rotate(180deg);">Vane Motor</p>
<p style="writing-mode: vertical-rl; transform: rotate(180deg);">Gerotor Motor</p>		<p style="writing-mode: vertical-rl; transform: rotate(180deg);">Geroler Motor</p>
<p style="writing-mode: vertical-rl; transform: rotate(180deg);">Bent Axis Motor</p>		<p style="writing-mode: vertical-rl; transform: rotate(180deg);">In-line Piston Motor</p>

***IMPORTANT!** The addition of the rollers to the Geroler motor significantly reduces the friction between the Geroler Star and Geroler Ring. This makes the Geroler motor easier to turn, which saves energy and creates less wear compared to the Gerotor motor.

MOTOR FORMULAS

Calculating Motor Torque

To calculate a motor's torque, you need to know the motor's displacement (cu. in./rev.) and inlet pressure (PSI).

$$\text{Motor Torque (in.-lb)} = \frac{\text{Pressure (PSI)} \times \text{Displacement (cu. in./rev.)}}{\frac{2\pi}{\pi = 3.14}}$$

Example: What torque does a motor produce that has a displacement of 5.9 cu. in./rev. and an inlet pressure of 1,500 PSI?

$$\text{Motor Torque (in.-lb)} = \frac{1,500 \text{ PSI} \times 5.9 \text{ cu. in./rev.}}{6.28} = 1,409 \text{ in.-lb}$$

Calculating Motor Horsepower

To calculate a motor's horsepower, you need to know the motor's torque (in.-lb) and speed (RPM).

$$\text{Horsepower} = \frac{\text{Motor Torque (in.-lb)} \times \text{Speed (RPM)}}{63,024}$$

Example: How many horsepower can a hydraulic motor produce with a torque of 1,409 in.-lb running at 1,000 RPM?

$$\text{Horsepower} = \frac{1,409 \text{ in.-lb} \times 1,000 \text{ RPM}}{63,024} = 22.4 \text{ horsepower}$$

Calculating Motor Speed

To calculate a motor's speed, you need to know the motor's inlet flow (GPM) and displacement (cu. in./rev.).

$$\text{Motor Speed (RPM)} = \frac{\text{Flow (GPM)} \times 231}{\text{Displacement (cu. in./rev.)}}$$

Example: What is the speed of a hydraulic motor with an inlet flow of 10 GPM and a displacement of 5.9 cu.in. /rev?

$$\text{Motor Speed (RPM)} = \frac{10 \text{ GPM} \times 231}{5.9 \text{ cu. in./rev.}} = 391.5 \text{ RPM}$$

HYDRAULIC DIRECTIONAL CONTROL VALVE DEFINITIONS

Closed Centre vs. Open Centre

Open center valves are used with fixed displacement pumps and have an “open path” for the oil to return back to the reservoir when the directional control valve is in the neutral (center) position. Closed center valves are used with variable displacement pumps and block the oil flow from going back to the reservoir when the directional control valve is in the neutral (center) position.

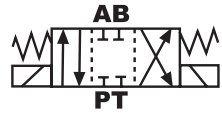

Closed Center

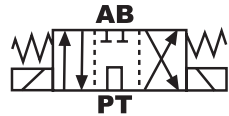

Open Center

Power Beyond

To understand what a power beyond is and why it is required, let's first talk about the internal passages of a mobile valve. The three passages are the open centre passage, the pressure passage and the return passage. The open centre passage and pressure passage are exposed to the higher pressures of the control valve. The return passage is solely exposed to the low pressure of the return to tank side of the valve.

When you want to run two valves in series (one after another) your first thought may be to take the hose from the Tank (Return) side of the first valve and run it into the Pressure (Inlet) side of the second valve. While this will work, it creates a dangerous situation. When the downstream valve is used to control a hydraulic cylinder or motor, the upstream valve will be pressurized to the same pressure as this valve. This is sometimes referred to as “backpressure”. The return passage of the upstream valve will also be exposed to this high pressure, and can cause the valve to crack.

The power beyond sleeve will thread into the upstream valve and block the return passage from the open centre and pressure passage. This will prevent the return passage from being subject to the high pressure created by the downstream valve and eliminate the danger of cracking the valve.

Load Checks

While it is often thought the purpose of a load check in a directional control valve is to hold the load in position, this is not the case. The load check function is to prevent the load from falling when the valve handle is shifted. It accomplishes this by temporarily stopping the oil flow when the valve handle is shifted, until the pump can develop enough pressure to push oil past the check and extend the cylinder.

VALVE SPOOL CONFIGURATIONS DEFINITIONS

There are four primary types of valve spool configurations.

Double Acting

The double acting spool directs flow to either port of a hydraulic cylinder or motor. The low pressure flow from the other cylinder or motor port is returned back through the valve to the reservoir.

When the spool is in the centre neutral position, both of the ports are blocked and oil flows through the valve back to the reservoir.

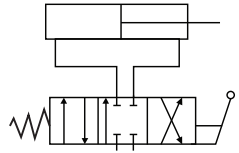

Single Acting

The single acting spool directs flow to the port of the single acting cylinder, or to only one port of a unidirectional motor. The return flow from the cylinder goes through the same port of the valve, relying on gravity or load on the cylinder to push it back to the reservoir.

The return flow from the motor goes directly to the reservoir. When the spool is in the centre neutral position, the port is blocked and oil flows through the valve back to the reservoir.

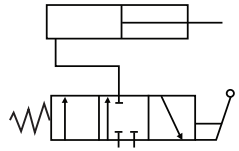

Motor Spool

The motor spool is typically used to direct flow to a hydraulic motor. It acts the same as the double acting spool, allowing the motor to turn in either direction. The difference between the motor spool and double acting spool is the centre neutral position. The motor spool has both work ports connected back to the tank in this position. This allows the motor to freewheel to a stop, instead of the ports being blocked and the motor being brought to an abrupt stop. This prevents pressure spikes in the system that can damage hydraulic components.

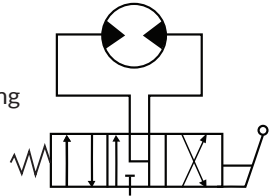

Float Spool

The float spool is a double acting spool with an additional position. This fourth position is similar to the centre neutral position of the motor spool, which has both of the work ports connected back to the tank. Float spools are used in applications like front end loaders or graders where the bucket or blade must follow the contour of the ground.

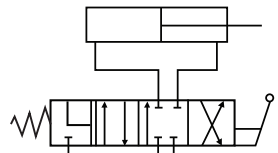

PROJECT SHOWCASE

INNOVATIVE AND INTERESTING PROJECTS BUILT BY OUR CUSTOMERS FROM ACROSS CANADA!

ATV FRONT LOADER

Here's another nicely designed ATV front loader. With some careful planning, a little online research, and a few trips to Princess Auto, Alain built a front loader that looks good and works great. The world of hydraulics can be a bit intimidating at first, but that didn't stop him from turning his ATV into a practical little workhorse.



ALAIN NEAR SUDBURY, ON

SHARE YOUR PROJECT!



Scan here to submit your project to our Project Showcase!
Share your inventive and creative project with the
Princess Auto community.

POWER UNIT BATTERY CABLE SELECTION

One of the most important steps when installing a 12V DC power unit is selecting the cables that run from the battery to the power unit. These cables must be the proper gauge to prevent voltage drop from occurring, which can negatively affect the solenoids and cause the cartridge valves not to operate properly. This may result in the power unit not functioning correctly, preventing the cylinder from retracting, or causing it to continue extending when either of the remote buttons are pushed.

The 1,600W power unit motor can draw up to 270A under full load. Refer to the Cable Selection Chart to choose the correct gauge cable based on the maximum current draw and cable length.



Member of the Fluid Power Society

The International Fluid Power Society (IFPS) is a nonprofit professional organization of individuals dedicated to enhancing the quality of certifications, educational opportunities, technology evolution, and professionalism within the fluid power and motion control industry.

CABLE SELECTION CHART

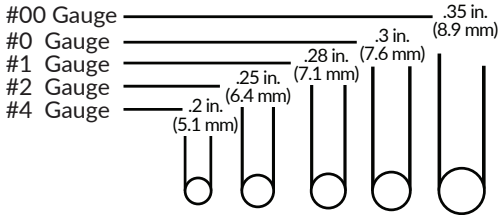

⚠ PLEASE REMOVE ALL RINGS, WATCHES AND JEWELRY PRIOR TO DOING ANY ELECTRICAL WORK.

Actual area of battery cable copper strand bundle. (Insulation NOT included)

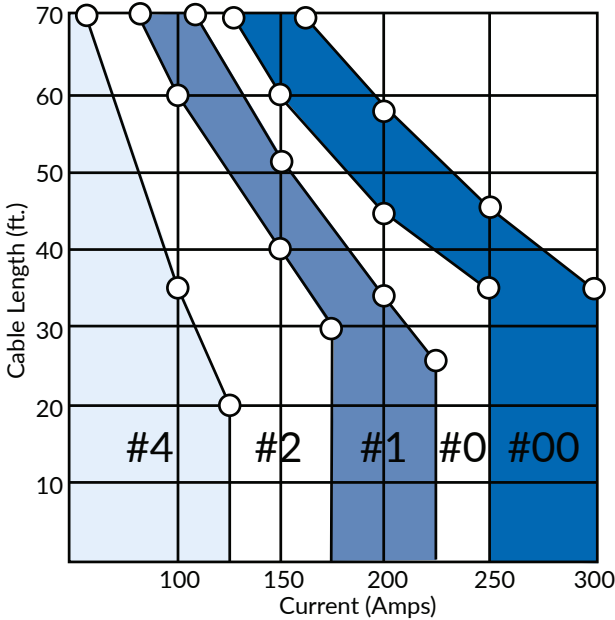

- Use the chart to select the correct cable gauge size based on the cable length (ft) and maximum current draw (Amps) required. For best results, we recommend that you increase your cable gauge 1 or 2 sizes above the minimum shown in the chart.
- Curve describes a 1 volt loss in the battery cable itself.
- Total length of the battery cable(s) including all ground cables.
- Example : With maximum current draw of 200 amps and total cable length of 28 ft. (8.5 m), select #1 gauge or larger.

HYDRAULIC FITTINGS

THE MOST COMMON TYPES OF FITTING THREADS IN HYDRAULICS ARE JIC 37°, NPT, ORB, ORFS, BSPP AND METRIC

JIC 37° FITTING

Both the male and female halves of this fitting have 37° seats. The fittings seal when the seats of the male and female connectors come in contact, while the threads hold the connection together mechanically.

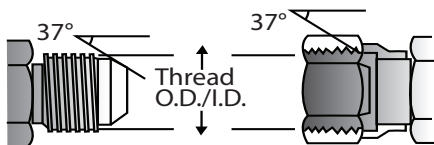

Size (inches)	Dash Size	Thread Size	Male Thread O.D. (inches)	Female Thread I.D. (inches)
1/8	02	5/16 - 24	0.31	0.27
3/16	03	3/8 - 24	0.38	0.34
1/4	04	7/16 - 20	0.44	0.39
5/16	05	1/2 - 20	0.50	0.45
3/8	06	9/16 - 18	0.56	0.51
1/2	08	3/4 - 16	0.75	0.69
5/8	10	7/8 - 14	0.88	0.81
3/4	12	1-1/16 - 12	1.06	0.98
7/8	14	1-3/16 - 12	1.19	1.10
1	16	1-5/16 - 12	1.31	1.23
1-1/4	20	1-5/8 - 12	1.63	1.54
1-1/2	24	1-7/8 - 12	1.88	1.79
2	32	2-1/2 - 12	2.50	2.42

NOTICE

DO NOT use Thread Tape or Sealant as it can introduce contaminants into the system and cause leakage at the fitting.

NATIONAL PIPE THREAD FITTING (NPT)

The male and female halves of this fitting are tapered. When they are threaded together they seal by deformation of the threads.

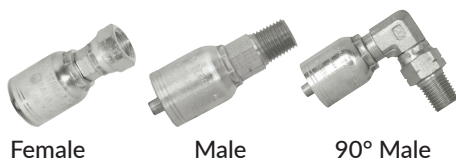
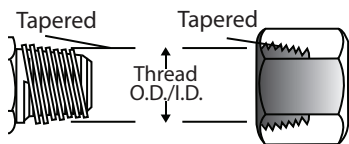

Size (inches)	Dash Size	Thread Size	Male Thread O.D. (inches)	Female Thread I.D. (inches)
1/8	02	1/8 - 27	0.41	0.38
1/4	04	1/4 - 18	0.54	0.49
3/8	06	3/8 - 18	0.68	0.63
1/2	08	1/2 - 14	0.84	0.77
3/4	12	3/4 - 14	1.05	0.98
1	16	1 - 11-1/2	1.32	1.24
1-1/4	20	1-1/4 - 11-1/2	1.66	1.58
1-1/2	24	1-1/2 - 11-1/2	1.90	1.82
2	32	2 - 11-1/2	2.38	2.30

FREE*

HOSE
CUTTING,
CLEANING
AND
CRIMPING



*For all hydraulic hose and fittings purchased at Princess Auto.

O-RING FACE SEAL FITTING (ORFS)

The male fitting has a straight thread and an O-Ring in the face. The female fitting has a straight thread and a machined flat face. The seal takes place by compressing the O-Ring on the flat face of the female. The threads hold the fitting mechanically.

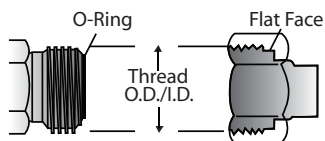

Male



Female

Size (inches)	Dash Size	Thread Size	Male Thread O.D. (inches)	Female Thread I.D. (inches)
1/4	04	9/16 - 18	0.56	0.51
3/8	06	11/16 - 16	0.69	0.63
1/2	08	13/16 - 16	0.82	0.75
5/8	10	1 - 14	1.00	0.93
3/4	12	1-3/16 - 12	1.19	1.11
1	16	1-7/16 - 12	1.44	1.36
1-1/4	20	1-11/16 - 12	1.69	1.61
1-1/2	24	2 - 12	2.00	1.92

NOTICE

DO NOT use Thread Tape or Sealant as it can introduce contaminants into the system and cause leakage at the fitting.

O-RING BOSS FITTING (ORB)

The male fitting has a straight thread and an O-Ring. The female fitting has a straight thread, a machined surface, and is chamfered to accept the O-Ring. The seal takes place by compressing the O-Ring into the chamfer, while the threads hold the connection mechanically.

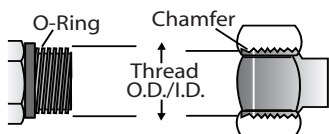

Male



Female

Size (inches)	Dash Size	Thread Size	Male Thread O.D. (inches)	Female Thread I.D. (inches)
1/8	02	5/16 - 24	0.31	0.27
3/16	03	3/8 - 24	0.38	0.34
1/4	04	7/16 - 20	0.44	0.39
5/16	05	1/2 - 20	0.50	0.45
3/8	06	9/16 - 18	0.56	0.51
1/2	08	3/4 - 16	0.75	0.69
5/8	10	7/8 - 14	0.88	0.81
3/4	12	1-1/16 - 12	1.06	0.98
7/8	14	1-3/16 - 12	1.19	1.10
1	16	1-5/16 - 12	1.31	1.23
1-1/4	20	1-5/8 - 12	1.63	1.54
1-1/2	24	1-7/8 - 12	1.88	1.79
2	32	2-1/2 - 12	2.50	2.42

NOTICE

DO NOT use Thread Tape or Sealant as it can introduce contaminants into the system and cause leakage at the fitting.

BRITISH STANDARD PARALLEL PIPE FITTING (BSPP)

The male and female halves of this fitting both have straight threads. The female swivel has a tapered nose, which seals on the cone seat of the male. The threads hold the fitting mechanically.

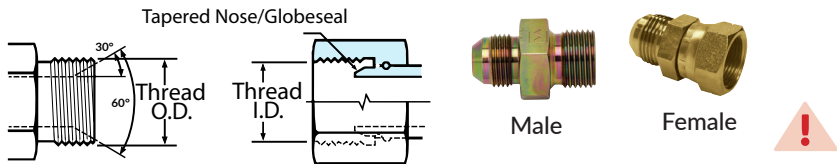

Size (inches)	Dash Size	Thread Size	Male Thread O.D. (inches)	Female Thread I.D. (inches)
1/4	4	1/4-19	0.52	0.47
3/8	6	3/8-19	0.65	0.60
1/2	8	1/2-14	0.82	0.75
3/4	12	3/4-14	1.04	0.97
1	16	1-11	1.30	1.22
1-1/4	20	1-1/4-11	1.65	1.56
1-1/2	24	1-1/2-11	1.88	1.79
2	32	2-11	2.35	2.26

Metric Fitting (M) The male and female halves of this fitting both have straight threads. A washer with a bonded seal is used to seal the male and female threads. The threads hold the fitting mechanically.



Size	Thread Size	Male Thread O.D. (mm)	Female Thread I.D. (mm)
M8	M8X1.0	8	7
M10	M10X1.0	10	9
M12	M12X1.5	12	10.5
M14	M14X1.5	14	12.5
M16	M16X1.5	16	14.5
M18	M18X1.5	18	16.5

Size	Thread Size	Male Thread O.D. (mm)	Female Thread I.D. (mm)
M20	M20X1.5	20	18.5
M22	M22X1.5	22	20.5
M24	M24X1.5	24	22.5
M26	M26X1.5	26	24.5
M27	M27X2.0	27	25
M33	M33X2.0	33	31

PROPER HYDRAULIC HOSE INSTALLATION GUIDELINES

Following these guidelines will help you to extend the life of your hose(s) and avoid costly equipment breakdowns.

Straight Hose Installations

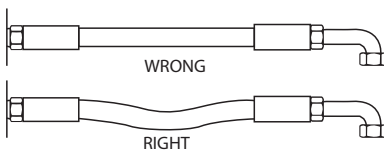

When hose installation is straight, allow enough slack in hose line to provide for length changes that will occur when pressure is applied.

Flexing Applications

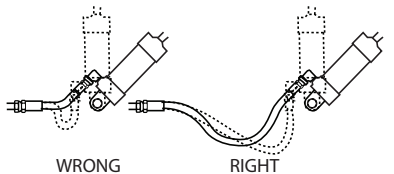

Adequate hose length is necessary to distribute movement on flexing applications, and to avoid abrasion.

Twists and Bends, Part 1

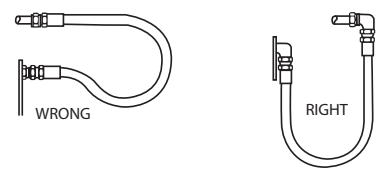

When radius is below the required minimum, use an angle adapter to avoid sharp bends.

Twists and Bends, Part 2

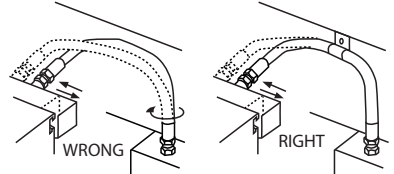

Avoid twisting of hose lines bent in two planes by clamping hose at change of plane.

Twists and Bends, Part 3

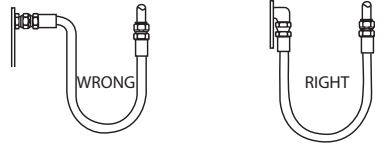

Use proper angle adapters to avoid sharp twists or bends in the hose.

Twists and Bends, Part 4

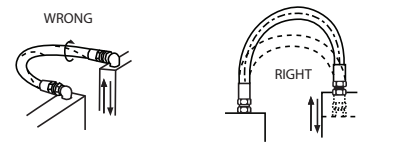

Prevent twisting and distortion by bending hose in same plane as the motion of the boss to which hose is connected.

Reduce Number of Pipe Fittings



Reduce number of pipe thread joints by using proper hydraulic adapters instead of pipe fittings.

Use 45° and/or 90° Adapters

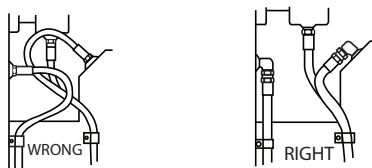

- Route hose directly by using 45° and/or 90° adapters and fittings.
- Avoid excessive hose length to improve appearance.

High Temperature

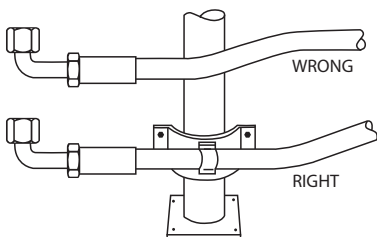

- High ambient temperatures shorten hose life, therefore ensure hose is kept away from hot parts.
- If this is not possible, insulate hose.

Relieve Strain

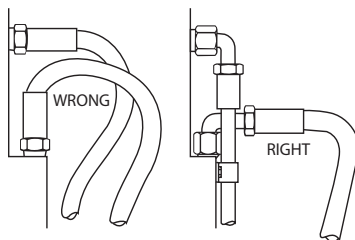

Elbows and adapters should be used to relieve strain on the assembly, and to provide neater installations that will be more accessible for inspection and maintenance.

Allowing for Length Change

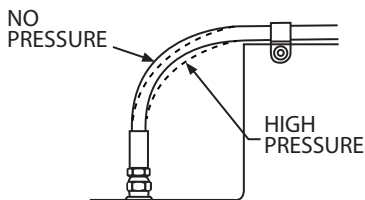

- To allow for length changes when hose is pressurized, do not clamp at bends.
- Curves will absorb changes.
- Do not clamp high and low pressure lines together.

Avoid Twisting Hose

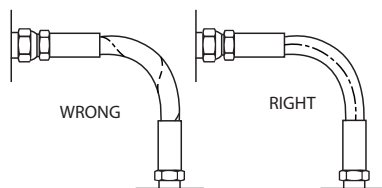

- When installing hose, make sure it is not twisted.
- Pressure applied to a twisted hose can result in hose failure or loosening of connections.

Avoid Collapse and Restriction

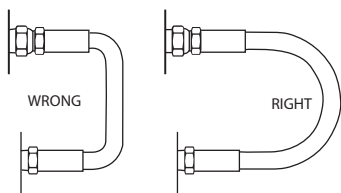

- To avoid hose collapse and flow restriction, keep hose bend radii as large as possible.
- Check the hose manufacturers specifications for minimum bend radii.

Avoid Abrasion

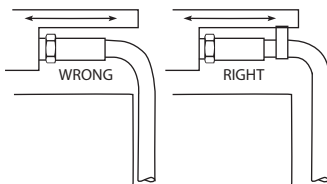

- Run hose in the installation so that it avoids rubbing and abrasion.
- Clamps are often required to support long hose runs or to keep hose away from moving parts.
- Use clamps of the correct size. A clamp too large allows hose to move inside the clamp and causes abrasion.

HYDRAULIC HOSE SIZE SELECTION TOOL

With this nomograph (page 35), you can easily select either the correct Hose ID size, Desired Flow Rate or Recommended Flow Velocity. If any two of these factors are known, the third can be determined.

To use this nomograph:

1. Pick the two known values.
2. Lay a straightedge to intersect the two values.
3. Intersection on the third vertical line gives the value of that factor.

Example: To find the Hose ID size for a Pressure Line consistent with a Flow Rate of 100 litres per minute (26 US gallons per minute), and a Flow Velocity of 4.5 meters per second (14.8 feet per second), connect Flow Rate to Flow Velocity and read Hose ID on centre scale.

Answer: The line crosses the Hose ID between -12 and -16 on the “all other dash sizes” side of Hose ID axis, so a -16 hose is required.

What are the advantages of 4-wire hydraulic hose over 2-wire hydraulic hose?

The 2-wire hydraulic hose has two steel wire braid reinforcing wraps and the 4-wire hose has 4 steel wire spiral reinforcing wraps. The 4-wire spiral wrap hose withstands higher pressures and is longer lasting than the 2-wire braided hose in high-impulse, heavy-duty cycle applications. This makes it ideal for use on construction, forestry, mining and other off-highway equipment.

HOSE SIZE SELECTION NOMOGRAPH

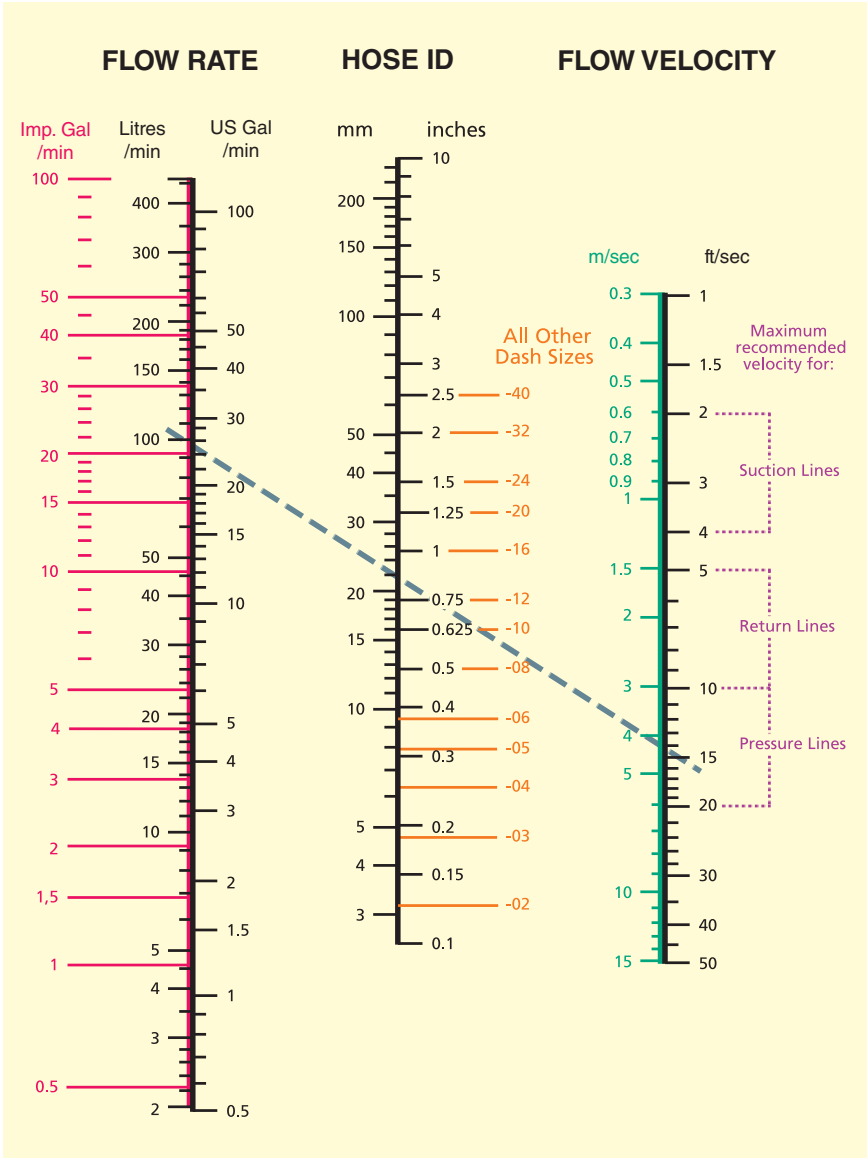

HYDRAULIC SYSTEM PRESSURE DROP

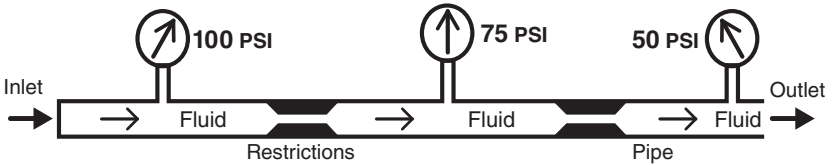

Pressure drop in a hydraulic system can be defined as the difference between the upstream and downstream pressure within the hydraulic system. This reduction in pressure is caused by the restriction(s) to the oil flow. When the pressure in the fluid is lowered by a restriction(s) then the energy stored in that fluid is less. This loss of energy is in the form of heat.

When designing a hydraulic system, you must allow for pressure drop as oil flows through the valves, fittings, hose, etc. If you start off with 3,000 PSI at your pump, you may only have 2,500 PSI at your actuator due to pressure drop. This loss of pressure must always be allowed for and is the reason you always design a hydraulic system by working from the actuator (cylinder, motor) back. In our previous example if you did need 3,000 PSI at the actuator to do the work you would need the pump to produce 3,500 PSI as 500 PSI is being lost to pressure drop and given off as heat.

Since the loss of pressure and creation of heat is both inefficient and can be harmful to a hydraulic system we want to eliminate pressure drop as much as possible. This involves selecting large enough hoses, as few fittings as possible, eliminating or reducing 90° fittings and making sure components match your maximum pump flow. By paying attention to pressure drop when building your hydraulic system, you will save energy, eliminate excess heat that could damage your oil and components and save money.

HYDRAULIC HOSE PRESSURE DROP CHART

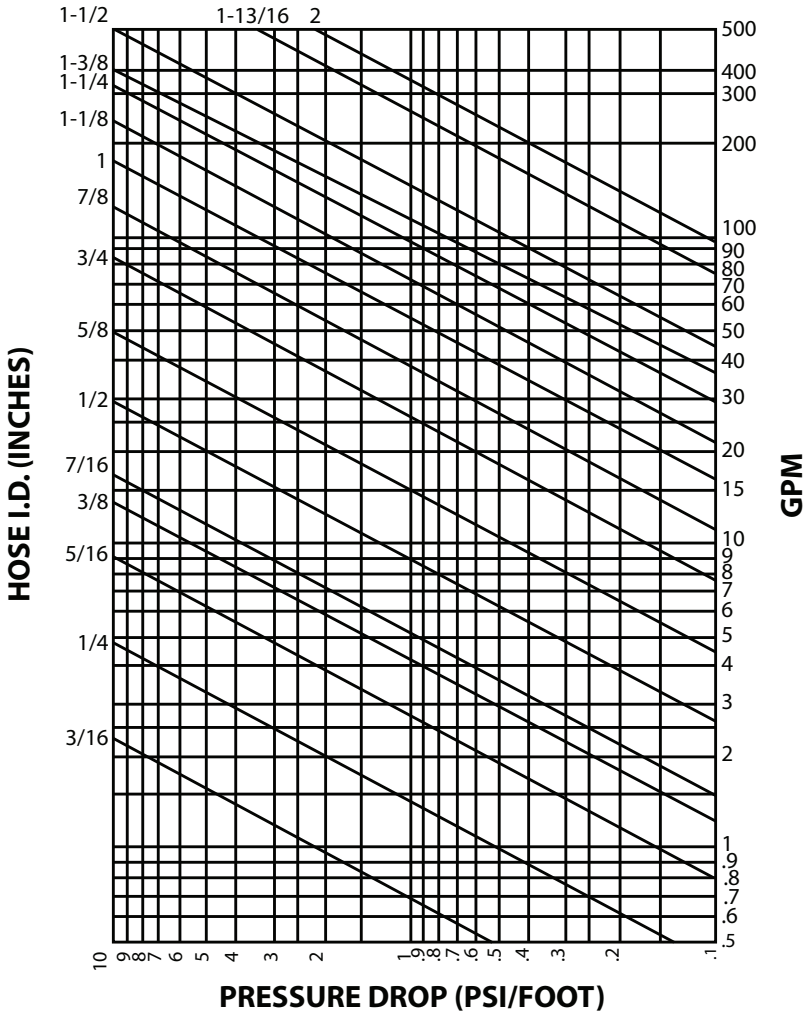

Examples:

What is the pressure drop per foot of 1/4 in. hose at 5 GPM? $\frac{10 \text{ PSI}}{5 \text{ GPM}}$

What is the pressure drop per foot of 3/8 in. hose at 10 GPM? $\frac{5.5 \text{ PSI}}{5 \text{ GPM}}$

What is the pressure drop per foot of 1/2 in. hose at 20 GPM? $\frac{5 \text{ PSI}}{5 \text{ GPM}}$

HYDRAULIC OIL AND FILTRATION

VISCOSITY COMPARISON CHART

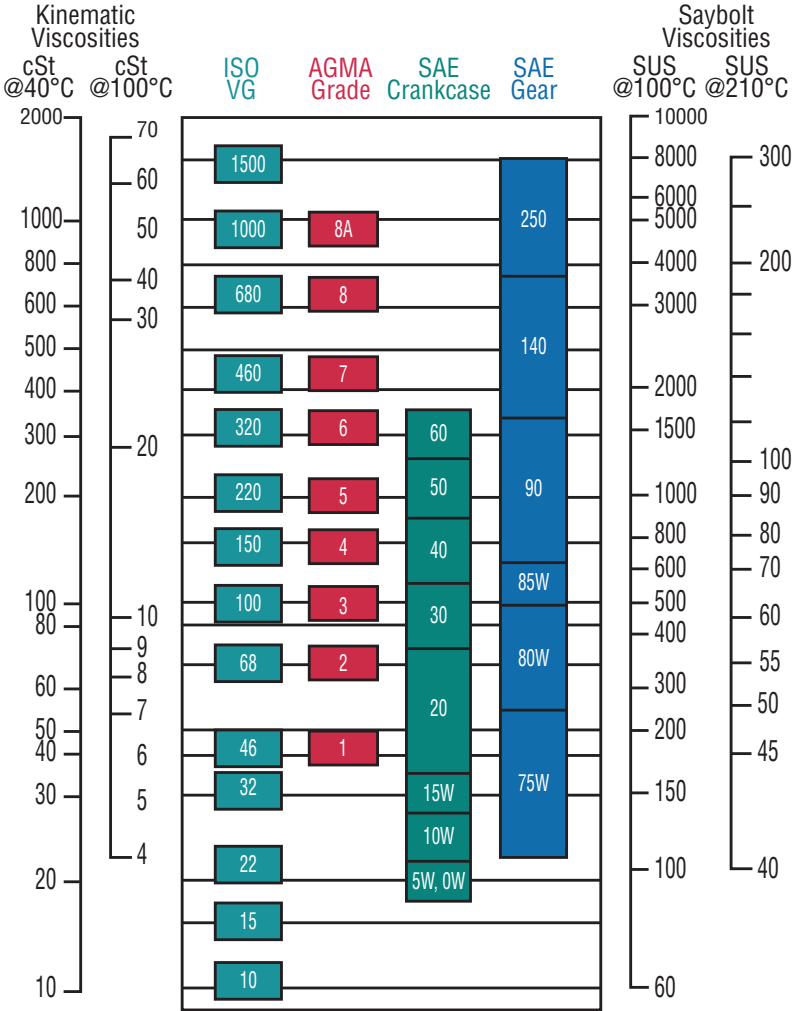

The Saybolt Universal Second (SUS or SSU) and Centistoke (cSt) ratings are both measures of kinematic viscosity, which describes the oils flow behavior under the influence of Earth's gravity.

FILTRATION

What is Beta Ratio?

Beta ratio (symbolized by β) is a formula used to calculate the filtration efficiency of a particular fluid filter using base data obtained from multi-pass testing. In a multi-pass test, fluid is continuously injected with a uniform amount of contaminant (ISO medium test dust), then pumped through the filter unit being tested. Filter efficiency is determined by monitoring oil contamination levels upstream and downstream of the test filter at specific times. An automatic particle counter is used to determine the contamination level. Through this process, an upstream to downstream particle count ratio is developed, known as the beta ratio. The formula used to calculate the beta ratio is:

$$\text{Beta ratio}(x) = \frac{\text{Particle count in upstream oil}}{\text{Particle count in downstream oil}}$$

Where (x) is a given particle size

Rating Efficiency

2	-	50%
10	-	90%
75	-	98.7%
100	-	99%
200	-	99.5%
1,000	-	99.9%

Example: $\beta_4 = 200$ signifies that there are 200 times as many particles that are 4 μm and larger upstream as downstream. This is 99.5% efficiency.

Example: $\beta_5 = 1,000$ indicates that there are 1,000 times as many particles that are 5 μm and larger upstream as downstream. This is 99.9% efficiency.

ISO CLEANLINESS CODE FOR HYDRAULIC OIL

You may have noticed that manufacturers of hydraulic components will frequently recommend a cleanliness rating for the hydraulic oil. An example of this cleanliness code would be 18/16/13. Once you know this code, you can select the filter that will provide this level of filtration.

The ISO Cleanliness Code, ISO 4406, is perhaps the most widely used international standard for representing the contamination level of industrial fluid power systems. Under ISO 4406, cleanliness is classified by a three-number code, e.g. 18/16/13, based on the number of particles greater than 4 μm , 6 μm and 14 μm respectively in a known volume of fluid. Using the table below, we can see a cleanliness rating of 18/16/13 would mean that there were:

- 1,300 - 2,500 particles greater than 4 microns in size
- 320 - 640 particles greater than 6 microns in size, and
- 40 - 80 particles greater than 14 microns in size.

THE FULL TABLE OF RANGES FOR ISO 4406 IS SHOWN BELOW

Range Number	# of Particles per ml	
	More Than	Up to and Including
24	80,000	160,000
23	40,000	80,000
22	20,000	40,000
21	10,000	20,000
20	5,000	10,000
19	2,500	5,000
18	1,300	2,500
17	640	1,300
16	320	640
15	160	320
14	80	160
13	40	80
12	20	40
11	10	20
10	5	10
9	2.5	5
8	1.3	2.5
7	0.64	1.3
6	0.32	0.64

SUGGESTED ACCEPTABLE CONTAMINATION LEVELS

ISO Code Numbers	Type of System	Typical Components	Sensitivity
23/21/17	Low pressure systems with large clearances		Low
20/18/15	Typical cleanliness of new hydraulic oil straight from the manufacturer. Low pressure heavy industrial systems or applications where long-life is not critical.	Flow control valves Cylinders	Average
19/17/14	General machinery and mobile systems Medium pressure, medium capacity	Gear pumps/motors	Important
18/16/13	World Wide Fuel Charter cleanliness standard for diesel fuel delivered from the filling station nozzle. High quality reliable systems. General machine requirements	Valve and piston pumps/motors Directional and pressure control valves	Very important
17/15/12	Highly sophisticated systems and hydrostatic transmissions	Proportional valves	Critical
16/14/11	Performance servo and high pressure long-life systems e.g. Aircraft machine tools, etc.	Industrial servo valves	Critical
15/13/09	Silt sensitive control system with very high reliability Laboratory or aerospace	High performance servo valves	Super critical

IMPORTANT! The three figures of the ISO code numbers represent ISO level contamination grades for particles of $>4\mu\text{m}$, $>6\mu\text{m}$ and $>14\mu\text{m}$ respectively.

SELECTING YOUR HYDRAULIC FILTER

A good rule of thumb when selecting your return line hydraulic oil filter is to pick one that is rated for 1-1/2 times your pump's maximum flow. So if the maximum flow your pump puts out is 10 GPM you should select a filter that is rated for 15 GPM.

RETURN LINE OIL FILTER

Benefits of the return line oil filter are that as oil travels through the system it will pick up any contaminants and be cleaned by the filter before returning to the tank. This will allow the pump to always pick up clean oil.

SUCTION LINE OIL FILTER

Suction line oil filters will clean the oil as it leaves the reservoir to prevent contamination from entering the pump and hydraulic system. When using a suction filter you must be careful not to create cavitation in your pump. To help avoid this make sure the suction filter is rated at least 4 times the pump flow and should not have a micron rating smaller than 25.

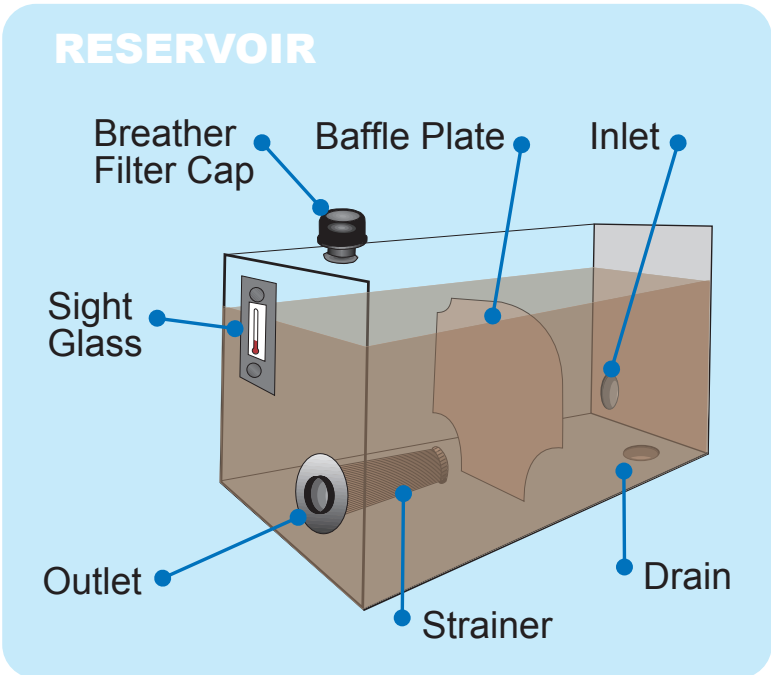

THE HYDRAULIC RESERVOIR

Hydraulic reservoirs perform four important functions.

- #1 - Store the hydraulic oil
- #2 - Provide cooling
- #3 - Allow air to separate out
- #4 - Allow debris to settle out

SELECTING YOUR HYDRAULIC RESERVOIR

For mobile hydraulic systems, the ideal reservoir size would be 2 to 3 times the maximum pump flow. This volume of oil will result in good heat dissipation and allow the oil to move slower through the reservoir, so air can be released and contaminants can settle out. If you had a pump that puts out 10 GPM, the ideal reservoir size would be 20 to 30 gallons. There are a lot of variables that are important to consider when choosing the size of the reservoir.

- Higher efficiency systems with components that have less pressure drop will result in less heat generation.
- The “duty cycle” of the application. Low duty cycle applications generate less heat and create fewer contaminants than higher duty cycle applications.
- An external oil cooler will help dissipate heat from the hydraulic system so a smaller reservoir can be used.

When choosing a hydraulic reservoir, consider these factors and choose a reservoir large enough to meet your needs. Never drop below 1 times the maximum pump flow, as anything smaller may be problematic.

Oil operating temperature should not exceed a maximum of 82°C (180°F). Having the hydraulic oil between 50°C to 60°C (120°F to 140°F) is generally considered the optimum operating temperature range. High temperatures result in rapid oil deterioration and may require an oil cooler or a larger reservoir. By keeping the hydraulic oil within the optimum temperature range, the service life of the hydraulic oil and system components will be increased.

SEAL COMPATIBILITY TABLE

Type of Fluid	NBR (Nitrile, Buna-n)	Polyacrylate	Silicone	VITON (FPM)	Teflon (PTFE)
Engine Oil	E	E	G	E	E
Gear Oil	G	G	X	E	E
Turbine Oil No. 2	G	G	G	E	E
Machine Oil No. 2	E	E	F	E	E
Automatic Transmission	E	E	F	E	E
Hydraulic Oil	E	E	F	E	E
Hydraulic Oil (synthetic)	X	X	G	E	E
Gasoline	F	X	X	E	E
Light Oil/Kerosene	F	X	X	G	E
E.P. Lubricants	G	E	X	E	E
Water-Glycol	E	X	G	F	E
Alcohol	E	X	G	F	E
Diesel	E	X	X	E	E
Acetone	X	X	F	X	E
Salt Water	E	X	E	E	E
Calcium Carbonate	E	X	E	E	E
Dextron	E	X	X	E	E
Brake Fluid	X	X	X	X	E

E = Excellent

G = Good

F = Fair

X = Not recommended

HYDRAULIC SYSTEM TROUBLESHOOTING

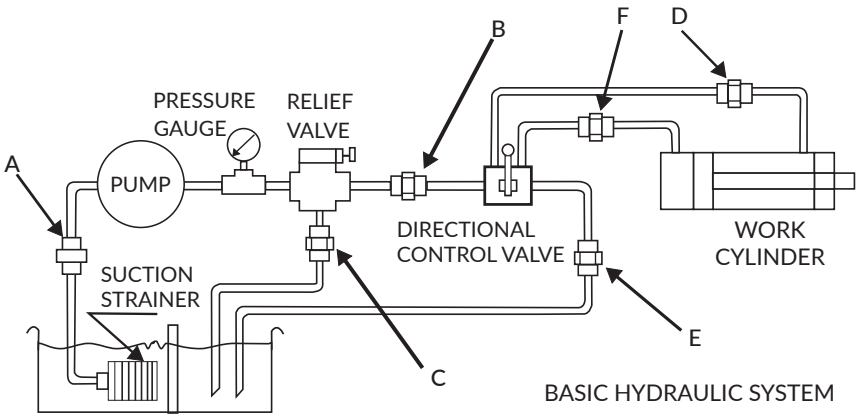

Many hydraulic system failures have a number of things in common. There is usually either a gradual or sudden loss of pressure within the hydraulic system causing a loss of power or speed at the actuators (cylinders or motors). The cylinders or motors may stop moving even under a small load or they may not work at all.

To troubleshoot a hydraulic system, it is important to follow a logical order of testing procedures to help isolate which component is causing the problem.

Step 1

- Check the suction strainer.
- A dirty suction strainer causes excessive vacuum at the suction side of the pump, which results in cavitation and damage to the pump.
- It is located on the pump suction line or in the oil reservoir. Remove the suction strainer (Disconnect A) for inspection and it should be cleaned before re-installation.

Step 2

- If cleaning the suction strainer does not correct the trouble, test the pump and relief valve.
- Disconnect at point B so that only the pump, relief valve, and pressure gauge remain in the pump circuit.
- Plug both ends of the plumbing that were disconnected.

- The pump is now deadheaded into the relief valve. Start the pump and watch for pressure build-up on the pressure gauge while tightening the adjustment on the relief valve.
- If full system rated pressure can be developed, the pump and relief valve are operating correctly, and the trouble is to be found further down the line.
- If full pressure cannot be developed in this test, continue with Step 3.

Step 3

Test the pump

- Disconnect the reservoir return line from the relief valve at point C.
- Attach a short length of hose to the relief valve outlet. Hold the open end of this hose over the reservoir filler opening so the rate of oil flow can be observed.
- Start the pump and run the relief valve adjustment up and down while observing the flow through the hose.
- If the pump is bad, there will probably be a full stream of oil when the relief adjustment is backed off, but this flow will diminish or stop as the adjustment is increased.
- This decrease in oil flow is caused by the oil slipping across the pumping elements inside the pump. This can mean a worn-out pump. High slippage in the pump will also cause the pump to run considerably hotter than the oil reservoir temperature. In normal operation a good pump will probably run about 11°C (20°F) above the reservoir temperature. If greater than this, excess slippage, caused by wear, may be the cause.
- Check also for slipping belts, sheared shaft pin or key, broken shaft, broken coupling, or loosened set screw.

Test the relief valve

- If the gauge pressure does not rise above a low value, say 100 PSI, and if the volume of flow does not substantially decrease as the relief valve adjustment is tightened, the relief valve is probably at fault and should be cleaned or replaced.

Step 4

- If the pump and relief valve are good, test the cylinder for worn-out or defective seals.
- Extend the cylinder all the way out until it is at the end of its stroke.
- Remove the rod end hose at point D from the cylinder and place it in the fill port of the reservoir.
- While watching for any leakage from the end of the hose use the directional control valve to dead head the cylinder until it is at maximum system pressure (oil will go over the relief). If no oil comes out of the hose the oil is not bypassing the cylinder seals so they are OK.

Step 5

- Check the directional control valve next. Although it does not often happen, an excessively worn valve spool can slip enough oil to prevent build-up of maximum pressure.
- Symptoms of this condition are a loss of cylinder speed together with difficulty in building up to full pressure, even with the relief valve adjusted to a high setting.
- Test the directional control valve by disconnecting the tank return line from the directional control valve at (E). Hold the open end of this hose over the reservoir filler opening so the rate of oil flow can be observed.
- Disconnect both cylinder lines at points D and F and plug the lines on the valve side.
- Shift and hold the valve in one of the working positions. (If the directional control valve has a relief make sure it is set above the pressure of the system relief for this test.)
- If any flow comes out of the tank return line while the valve is shifted and under pressure, there is spool leakage.
- While it is normal to have a very small amount of spool leakage, too much will cause the cylinder to move slowly with less force.

PROJECT SHOWCASE

**INNOVATIVE AND
INTERESTING
PROJECTS BUILT BY
OUR CUSTOMERS
FROM ACROSS
CANADA!**



WINTER PROJECT
WORK SAVER



TRACTOR WITH LOADER

SHARE YOUR PROJECT!



Scan here to submit your project to our Project Showcase!
Share your inventive and creative project with the
Princess Auto community.

CONVERSION TABLES

TO CONVERT >>>	INTO >>>	MULTIPLY BY...
Into <<<	To Convert <<<	Divide by...
Atmospheres	PSI (pounds per square inch)	14.7
BTU	Foot Pounds	778.3
BTU per hour	Watts	0.2931
BTU per minute	Horsepower	0.02356
Centimetres	Inches	0.3937
Cubic Centimetres	Gallons (U.S. Liquid)	0.0002642
Cubic Centimetres	Litres	0.001
Cubic Feet	Cubic Inches	1728
Cubic Feet	Gallons (U.S. Liquid)	7.48052
Cubic Inches	Cubic Feet	0.0005787
Cubic Inches	Gallons (U.S. Liquid)	0.004329
Feet	Meters	0.3048
Feet	Miles	0.0001894
Feet per Minute	Miles per Hour	0.01136
Feet per Second	Miles per Hour	0.6818
Foot-Pounds	BTU	0.001286
Foot-Pounds per Minute	Horsepower	0.0000303
Foot-Pounds per Second	Horsepower	0.001818
Gallons (U.S. Liquid)	Cubic Feet	0.1337
Gallons of Water	Pounds of Water	8.3453
Horsepower	BTU per Minute	42.44

TO CONVERT >>>	INTO >>>	MULTIPLY BY...
Into <<<	To Convert <<<	Divide by...
Horsepower	Foot-Pounds per Minute	33,000
Horsepower	Foot-Pounds per Second	550
Horsepower	Watts	745.7
Inches	Centimetres	2.54
Inches of Mercury	PSI (pounds per square inch)	0.4912
Inches of Water	PSI (pounds per square inch)	0.03613
Litres	Cubic Centimetres	1,000
Litres	Gallons (U.S. Liquid)	0.2642
Microns	Inches	0.00004
Miles	Feet	5,280
Miles per Hour (MPH)	Feet per Minute	88
Miles per Hour (MPH)	Feet per Second	1.467
Ounces (Weight)	Pounds	0.0625
Ounces (Liquid)	Cubic Inches	1.805
Pints (Liquid)	Quarts (Liquid)	0.5
PSI (pounds per square inch)	Atmospheres	0.06804
PSI (pounds per square inch)	Inches of Mercury	2.036
Quarts	Gallons	0.25
Square Feet	Square Inches	144
Watts	Horsepower	0.001341
-	-	-

TEMPERATURE CONVERSION TABLE

°C	°F	°C	°F	°C	°F	°C	°F	°C	°F	°C	°F	°C	°F
-40	-40	-10	14	20	68	50	122	80	176	110	230	140	284
-39	-38.2	-9	15.8	21	69.8	51	123.8	81	177.8	111	231.8	141	285.8
-38	-36.4	-8	17.6	22	71.6	52	125.6	82	179.6	112	233.6	142	287.6
-37	-34.6	-7	19.4	23	73.4	53	127.4	83	181.4	113	235.4	143	289.4
-36	-32.8	-6	21.2	24	75.2	54	129.2	84	183.2	114	237.2	144	291.2
-35	-31	-5	23	25	77	55	131	85	185	115	239	145	293
-34	-29.2	-4	24.8	26	78.8	56	132.8	86	186.8	116	240.8	146	294.8
-33	-27.4	-3	26.6	27	80.6	57	134.6	87	188.6	117	242.6	147	296.6
-32	-25.6	-2	28.4	28	82.4	58	136.4	88	190.4	118	244.4	148	298.4
-31	-23.8	-1	30.2	29	84.2	59	138.2	89	192.2	119	246.2	149	300.2
-30	-22	0	32	30	86	60	140	90	194	120	248	150	302
-29	-20.2	1	33.8	31	87.8	61	141.8	91	195.8	121	249.8	151	303.8
-28	-18.4	2	35.6	32	89.6	62	143.6	92	197.6	122	251.6	152	305.6
-27	-16.6	3	37.4	33	91.4	63	145.4	93	199.4	123	253.4	153	307.4
-26	-14.8	4	39.2	34	93.2	64	147.2	94	201.2	124	255.2	154	309.2
-25	-13	5	41	35	95	65	149	95	203	125	257	155	311
-24	-11.2	6	42.8	36	96.8	66	150.8	96	204.8	126	258.8	156	312.8
-23	-9.4	7	44.6	37	98.6	67	152.6	97	206.6	127	260.6	157	314.6
-22	-7.6	8	46.4	38	100.4	68	154.4	98	208.4	128	262.4	158	316.4
-21	-5.8	9	48.2	39	102.2	69	156.2	99	210.2	129	264.2	159	318.2
-20	-4	10	50	40	104	70	158	100	212	130	266	160	320
-19	-2.2	11	51.8	41	105.8	71	159.8	101	213.8	131	267.8	161	321.8
-18	-0.4	12	53.6	42	107.6	72	161.6	102	215.6	132	269.6	162	323.6
-17	1.4	13	55.4	43	109.4	73	163.4	103	217.4	133	271.4	163	325.4
-16	3.2	14	57.2	44	111.2	74	165.2	104	219.2	134	273.2	164	327.2
-15	5	15	59	45	113	75	167	105	221	135	275	165	329
-14	6.8	16	60.8	46	114.8	76	168.8	106	222.8	136	276.8	166	330.8
-13	8.6	17	62.6	47	116.6	77	170.6	107	224.6	137	278.6	167	332.6
-12	10.4	18	64.4	48	118.4	78	172.4	108	226.4	138	280.4	168	334.4
-11	12.2	19	66.2	49	120.2	79	174.2	109	228.2	139	282.2	169	336.2

WIRE MESH CONVERSIONS

U.S. Mesh	Microns	Inches
3	6730	0.2650
4	4760	0.1870
5	4000	0.1570
6	3360	0.1320
7	2830	0.1110
8	2380	0.0937
10	2000	0.0787
12	1680	0.0661
14	1410	0.0555
16	1190	0.0469
18	1000	0.0394
20	840	0.0311
25	710	0.0280
30	590	0.0232
35	500	0.0197
40	420	0.0165
45	350	0.0137

U.S. Mesh	Microns	Inches
50	297	0.0117
60	250	0.0098
70	210	0.0083
80	177	0.0070
100	149	0.0059
120	125	0.0049
140	105	0.0041
170	88	0.0035
200	74	0.0029
230	62	0.0024
270	53	0.0021
325	44	0.0017
400	37	0.0015
550	25	0.0009
800	15	0.0006
1250	10	0.0004
-	-	-

IMPORTANT! The Wire Mesh Chart shows the filtration size of strainers and filters in micron and inch ratings.

CUBIC CENTIMETERS TO HORSEPOWER CONVERSION TABLE (APPROXIMATION)

CC	HP
29	1
58	2
87	3
116	4
145	5

CC	HP
174	6
203	7
232	8
261	9
290	10

CC	HP
319	11
348	12
377	13
406	14
435	15

This table is a rough guideline to compare small gas engine cubic centimeter displacement to horsepower. Actual horsepower can vary due to compression differences, altitude, fuel/air mixture, etc.

HOW TO DETERMINE BELT LENGTH

This formula will calculate the length of a belt required to fit a two pulley drive system.

Pulley A

Diameter x 1.57

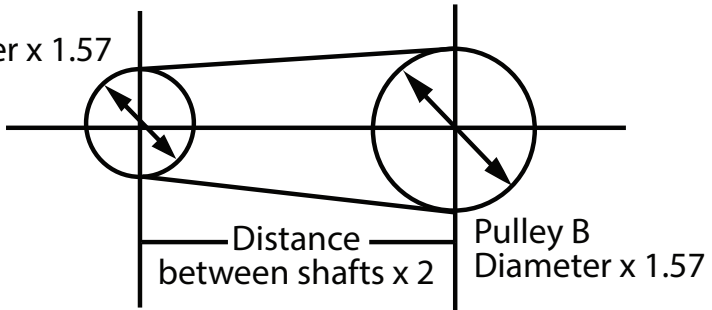

To find O.D. belt length:

$$\left(\text{O.D. of small pulley} + \text{O.D. of large pulley} \right) \times 1.57 + 2 \times \text{distance between shaft centres} = \text{O.D. belt length}$$

HOW TO DETERMINE THE SIZE AND SPEED OF PULLEYS AND SPROCKETS

The driving pulley/sprocket is called the Driver and the driven pulley/sprocket the Driven.

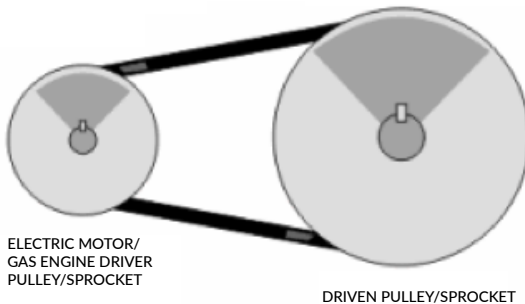

IMPORTANT! Use the number of teeth for sprockets instead of the pulley's diameter for the Driver and Driven formulas.

Formula #1

$$\text{Diameter of the Driver (in.)} = \frac{\text{Diameter of Driven (in.)} \times \text{Speed of Driven (RPM)}}{\text{Speed of Driver (RPM)}}$$

Example: You have a 4 inch pulley (Driven) on your hydraulic pump that you want to turn 1,750 RPM. The electric motor you are using is 3,450 RPM. What diameter of pulley (Driver) would you need on the electric motor?

$$\text{Diameter of the Driver (in.)} = \frac{4 \text{ in.} \times 1,750 \text{ RPM}}{3,450 \text{ RPM}}$$

$$\text{Diameter of the Driver (in.)} = 2 \text{ in.}$$

Formula #2

$$\text{Diameter of the Driven (in.)} = \frac{\text{Diameter of Driver (in.)} \times \text{Speed of Driver (RPM)}}{\text{Speed of Driven (RPM)}}$$

Example: You have an 8 inch pulley (Driver) on your electric motor that runs at 1,800 RPM. You want your pump to turn at 600 RPM. What diameter of pulley (Driven) do you need on the pump?

$$\text{Diameter of the Driven (in.)} = \frac{8 \text{ in.} \times 1,800 \text{ RPM}}{600 \text{ RPM}}$$

$$\text{Diameter of the Driven (in.)} = 24 \text{ in.}$$

Formula #3

$$\text{Speed of the Driver (RPM)} = \frac{\text{Diameter of Driven (in.)} \times \text{Speed of Driven (RPM)}}{\text{Diameter of Driver (in.)}}$$

Example: You have a 6 inch pulley (Driven) on your hydraulic pump that you want to turn 1,200 RPM. You have a 10 inch pulley (Driver) on your electric motor. What RPM would the electric motor need to run at?

$$\text{Speed of the Driver (RPM)} = \frac{6 \text{ in.} \times 1,200 \text{ RPM}}{10 \text{ in.}}$$

$$\text{Speed of the Driver (RPM)} = 720 \text{ RPM}$$

Formula #4

$$\text{Speed of the Driven (RPM)} = \frac{\text{Diameter of Driver (in.)} \times \text{Speed of Driver (RPM)}}{\text{Diameter of Driven (in.)}}$$

Example: You have a 10 in. pulley (Driver) on a 3,450 RPM electric motor and a 4 inch pulley (Driven) on hydraulic pump. What RPM would the pump rotate?

$$\text{Speed of the Driven (RPM)} = \frac{10 \text{ in.} \times 3,450 \text{ RPM}}{4 \text{ in.}}$$

$$\text{Speed of the Driven (RPM)} = 8,625 \text{ RPM}$$

SAFETY TIPS:

HYDRAULIC LEAKS

DANGER

A Potential Leak in a Hose – Never check for hydraulic leaks with your hands or fingers. This could result in burns or even worse an injection injury that could be fatal. The best way to check is to use a piece of cardboard and run it along the suspected area. The cardboard will absorb the fluid, pinpointing the leak's location.

A Potential Leak in a Fitting – If the leak appears to be coming from a fitting, do not tighten it. One extra turn of the wrench could cause a greater leak or cause the fitting to fail entirely. It is highly recommended to drain the system of hydraulic fluid before attempting to repair the connection.

HYDRAULIC TIP:

OVERHEATING IN HYDRAULIC SYSTEMS:

Some common causes are low reservoir levels, air contaminating the system, build-up of dirt in the air flow passages and excess friction within the components. As the temperature of the hydraulic fluid increases, the viscosity decreases and the friction within the components increase. If the temperature of the oil exceeds 82°C (180°F), it can seriously damage the system. Fix the problem by cleaning the air flow passages, checking and fixing any leaks in the system and decreasing the heat load by increasing heat dissipation.

ELECTRICAL

SELECTING THE CORRECT WIRE SIZE

Voltage drop refers to the amount of voltage lost over a specific length of wire. It will change as a function of the resistance of the wire and should not exceed 2%. If it does exceed 2%, the efficiency and the life of the equipment that it is powering will be greatly reduced.

MAX. WIRE LENGTH (FT.) BASED ON A 2% MAX. VOLTAGE DROP

120V AC		WIRE GAUGE				
Amps	Wattage	#14	#12	#10	#8	#6
1	120	450	700	1,100	1,800	2,800
5	600	90	140	225	360	575
10	1,200	45	70	115	180	285
15	1,800	30	47	75	120	190
20	2,400	-	36	57	90	140
25	3,000	-	-	45	72	115
30	3,600	-	-	38	60	95
40	4,800	-	-	-	45	72
50	6,000	-	-	-	-	57

240V AC		WIRE GAUGE				
Amps	Wattage	#14	#12	#10	#8	#6
1	240	900	1,400	2,200	3,600	5,600
5	1,200	180	285	455	720	1,020
10	2,400	90	140	225	360	525
15	3,600	60	95	150	240	350
20	4,800	-	70	110	180	265
25	6,000	-	-	90	144	210
30	7,200	-	-	75	120	175
40	9,600	-	-	-	90	130
50	12,000	-	-	-	-	105

BASIC ELECTRICAL FORMULAS

Interesting Fact:

When describing electrical voltage, current and resistance, a common analogy is a hydraulic system. In this analogy, voltage is represented by the hydraulic oil pressure, current is represented by the hydraulic oil flow and resistance is represented by the hydraulic system pressure drop (back pressure).

VOLTS	WATTS
$\text{Volts} = \frac{\text{Watts}}{\text{Amps}}$	$\text{Watts} = \text{Volts} \times \text{Amps}$

AMPS	RESISTANCE
$\text{Amps} = \frac{\text{Watts}}{\text{Volts}}$	$\text{Resistance Ohms} = \frac{\text{Volts}^2}{\text{Watts}}$

You have an electric motor rated at 120V AC and 10 amps.
What is the power usage in Watts?

$$\text{Watts} = \text{Volts} \times \text{Amps} \quad \text{Watts} = 120 \times 10 = 1,200$$

You have a 240V AC water heater element that uses 4,500 Watts of power.
How many Amps will it require?

$$\text{Amps} = \frac{\text{Watts}}{\text{Volts}} \quad \text{Amps} = \frac{4,500}{240} = 18.75$$

You have a 3,600 Watt motor that draws 30 Amps.
What voltage would be required?

$$\text{Volts} = \frac{\text{Watts}}{\text{Amps}} \quad \text{Volts} = \frac{3,600}{30} = 120$$

You have a 240V AC, 4,500 Watt heater element that you want to test to make sure it is still OK. You measure the resistance of the element with your Ohm metre. What should the Ohm reading be?

$$\text{Resistance Ohms} = \frac{\text{Volts}^2}{\text{Watts}} \quad \text{Ohms} = \frac{240^2}{4,500} = \frac{57,600}{4,500} = 12.8$$

THE ELECTRICAL FORMULA WHEEL

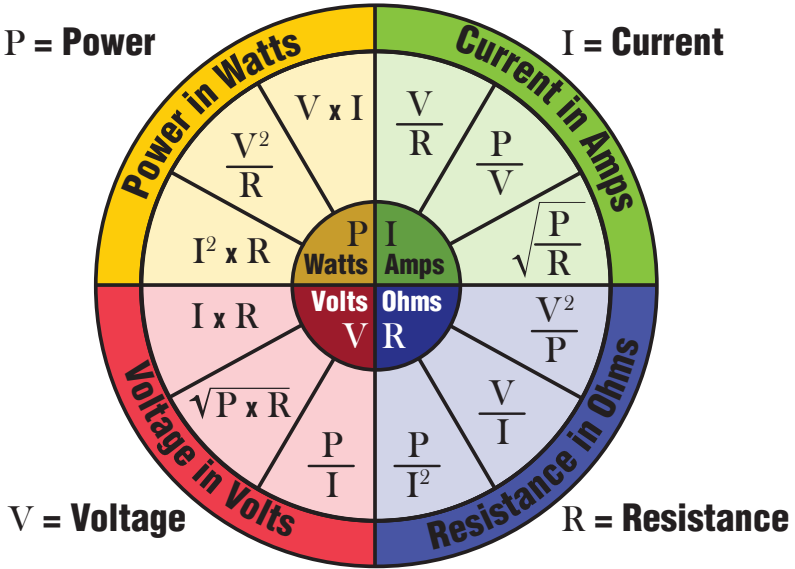



ONGOING COMMITMENT TO TRAINING

Princess Auto offers a comprehensive hydraulics training program to our Team Members. The program objectives include hydraulic systems, design and troubleshooting at various levels of experience. Team Members are able to earn certification after completing both a hands-on practical application and written test to verify their technical competency.

Actuator - A device that converts hydraulic power into mechanical force and motion. (Examples: hydraulic cylinders and motors.)

Amperage - The strength of an electric current expressed in amperes.

Area - The amount of space inside the boundary of a flat (2-dimensional) object such as a triangle or circle.

Beta Ratio - The amount, expressed as a ratio, of particles in a fluid upstream of a filter, divided by the amount of particles downstream, for a particular size particle.

Bi-Directional - Capable of functioning in two directions. Clockwise and counterclockwise.

Bore Diameter - The internal diameter of a tube, hose or pipe.

Circuit - A series of component parts connected to each other by fluid lines or passages. Usually part of a "system".

Closed Center System - A hydraulic system in which the control valves are closed in neutral, stopping oil flow. Flow in this system is varied, but pressure remains constant.

Cleanliness Code - Is used to quantify particulate contamination levels per milliliter of fluid at three sizes: $4\mu\text{[c]}$, $6\mu\text{[c]}$, and $14\mu\text{[c]}$. This ISO code is expressed in 3 numbers: 19/17/14.

Cylinder - A device for converting fluid power into linear motion.

Single Acting - A cylinder that can apply force in one direction only.

Double Acting - A cylinder that can apply force in either direction.

Telescopic - Telescopic cylinders are a segmented cylinder that provides an exceptionally long output travel from a very compact retracted length.

Dash Size - Dash size is an industry standard measuring system for hoses and fittings.

Displacement - The volume of oil displaced by one complete stroke or revolution (of a pump, motor, or cylinder).

Duty Cycle - Is the proportion of time that a component, device or system is operated. The duty cycle can be expressed as a ratio or as a percentage.

Directional Control Valve - A device for directing or preventing the oil flow in a system.

Efficiency - The ratio of output to input. Volumetric efficiency of a pump is the actual output, in GPM, divided by the theoretical or design output. The overall efficiency of a hydraulic system is the output power divided by the input power. Efficiency is usually expressed as a percent.

Effective Area - The surface area of the cylinder piston face that fluid pressure acts upon to provide force.

Filter - A mechanical device used to house a filter element.

Filter Element - A series of wire or fabric meshes that are bonded together by caps or perforated cylinders and are fitted into hydraulic system passages to strain fine particles and silt from fluid passed through the passage.

Float Spool - A spool valve design that connects the work ports to tank, usually in a detented fourth position, allowing a cylinder or motor to “float”.

Flow Control Valve, Pressure Compensated - A valve used to cause a variable pressure drop in a fluid passage, thus reducing the amount of fluid that may pass through the passage regardless of the pressure level at the inlet of the valve. Often fitted with a check valve that permits free flow of fluid in the opposite direction.

Flow Rate - The volume of fluid passing a point in a given time.

Flow Velocity - Is the speed that a fluid travels through a hose or pipe.

Force - A push or pull acting upon a body. In a hydraulic cylinder, it is the product of the pressure on the fluid, multiplied by the effective area of the cylinder piston. It is measured in pounds or tons.

GPM - Gallons per minute

Horsepower - The work produced per unit of time.

Hydraulics - The engineering science of liquid, pressure and flow.

ID - Inside Diameter

ISO - International Standards Organization

Kinematic Viscosity - A measure of the resistance to flow of a fluid, equal to its absolute viscosity divided by its density.

Line - A tube, pipe or hose for conducting a fluid.

Linear Actuator - A device for converting hydraulic energy into linear motion, e.g. a cylinder or ram.

Load Check - A device that prevents a load from dropping when a valve is shifted, until ample pressure and flow is available to hold or move the load.

Micron - A unit of length equal to one millionth of a meter.

Motor (Hydraulic) - A device for converting fluid energy into mechanical force and rotary motion. Basic design types include gear, vane and piston units.

Motor Spool - The two work ports are connected to the tank in the neutral position allowing a hydraulic motor to freewheel. Also prevents "dead stop" in a hydraulic motor by allowing gradual slow down when the valve is moved to neutral.

OD - Outside diameter

Ohm - Is the measurement of resistance in an electrical circuit. One ohm is equal to the resistance of a conductor through which a current of one ampere flows when a potential difference of one volt is applied to it.

Open Center System - A hydraulic system in which the control valves are open to continuous oil flow, even in neutral. Pressure in this system is varied, but flow remains constant.

O-Ring - A static and/or dynamic seal for curved or circular mating surfaces.

Particle Count - The visual or electronic summation of the quantity of particles, grouped by size, in a fluid sample of specified size.

Pi - The ratio of a circle's circumference to its diameter. Equal to 3.14.

Piston - A cylindrical part that moves or reciprocates in a cylinder and transmits or receives force to do work.

Port - The open end of a fluid passage. May be within or at the surface of a component.

Pour Point - The lowest temperature that a fluid will flow under specific conditions.

Power Beyond - An adapting sleeve that opens a passage from one circuit to another. Often installed in a valve port that is normally plugged.

Power Unit - An integral power supply unit usually containing a prime mover, pump, reservoir, relief valve and directional control.

Pressure Compensated - Maintains the same flow of oil regardless of pressure changes at the valves inlet or outlet ports.

Pressure Drop - The difference in pressure between any two points in a system or a component.

Prime Mover - Is an electric motor or gas engine that drives a hydraulic pump to convert mechanical energy into fluid energy.

PSI - Pounds per square inch

Pressure - Force of a fluid per unit area, usually expressed in pounds per square inch (PSI).

Pump - A device which converts mechanical force into hydraulic fluid power. Basic design types are gear, vane and piston units.

Fixed Displacement Pump - A pump in which the output per cycle cannot be varied.

Variable Displacement Pump - A pump in which the output per cycle can be varied.

Radius - The radius of a circle is the length of the line from the center to any point on its edge.

Reservoir - A container for keeping a supply of working fluid in a hydraulic system.

Rod - The chromed shaft attached to the piston inside the cylinder tube.

Rotary Actuator - A hydro-mechanical device that converts fluid flow into incremental rotary motion.

RPM - Revolutions per minute.

Saybolt Viscosity - Viscosity as determined by the number of seconds required for an oil heated to 54°C (130°F) for lighter oils and 99°C (210° F) for heavier oils, to flow through a standard orifice and fill a 60 milliliter flask.

Solenoid - An electromagnetic device that positions a hydraulic valve.

Spool - A term loosely applied to almost any moving cylindrically shaped part of a hydraulic component that moves to direct flow through the component.

Strainer - A coarse filter.

Stroke - (1) The length of travel of a piston in a cylinder. (2) Sometimes used to denote the changing of the displacement of a variable displacement pump.

Symbols, Schematic - Used as a short-hand on drawings to represent hydraulic system components.

Tank - See Reservoir.

Torque - The turning force of a hydraulic motor or rotary cylinder. Usually given in inch-pounds (in-lb) or foot-pounds (ft-lb).

Unidirectional - Moving or rotating in one direction only.

Valve - A device that controls either 1) pressure of fluid, 2) direction of fluid flow or 3) rate of flow.

Check Valve - A valve that permits flow in only one direction.

Cross-Over Relief Valve - Protects the hydraulic cylinder/motor, hoses, pump, etc. from high pressure spikes caused by shock loads.

Counterbalance Valve - Controls the rate of descent and prevents chatter in cylinder load lowering applications including truck boxes, tilt bed trailers and cranes.

Directional Control Valve - A valve that directs oil through selected passages. (Usually a spool or rotary valve design.)

Pressure Reducing Valve - A pressure control valve which limits outlet pressure.

Sequence Valve - A pressure control valve that directs flow in a preset sequence.

Relief Valve - A valve that limits the pressure in a system, usually by releasing excess oil.

Throttle Valve - Restrict the flow of oil to various components in a hydraulic system. They are adjustable from 0 GPM to their maximum rated capacity in one direction and capable of full flow in the other direction.

Unloading Valve - A valve that allows a pump to operate at minimum load by dumping the pump's excess oil at a low pressure.

Volt - The difference of potential that would drive one ampere of current against one ohm resistance.

Voltage Drop - The amount of voltage loss that occurs through all or part of a circuit due to resistance.

Viscosity - The measure of resistance of a fluid to flow.

Volume - The amount of fluid flow per unit time. Usually given as gallons per minute (GPM).

Watts - Is a unit of power that can be used to quantify the rate of energy transfer. (Watts=Volts x Amps).

Copyright © 2024 by Princess Auto Limited All rights reserved.
This book or any portion thereof may not be reproduced or used in any manner whatsoever without the express written permission of the publisher.

Printed in Canada

ISBN 978-0-9938013-0-3

475 Panet Road

Winnipeg, MB R2C 2Z1

princessauto.com

Printed May 2024



Have a question? Need help?
Email us at hydraulics@princessauto.com